

PREVOST

Pneumatic diagram

PNEUMATIC DIAGRAMS VIP BUS SHELL WITH INDEPENDENT SUSPENSION SYSTEM

NO:	D140382P0	REVISION :	D
-----	------------------	------------	----------

EFF. OC#	2010001	PRIOR TO OC#	2011095
EFF. VEH#	#B-1772	PRIOR TO VEH#	#C-1995

DR.	R. Bouillon	date	2011-11-04
CHK	Marc-Jose Handfield	appr	Marc-José Handfield

REV.	DATE	DESCRIPTION	PAGE	BY	CHK.	APPR.
A	2011-01-20	VIP with Independent Front Suspension IFS, Production Vehicle #B-1772...		Rob.	M.J.H.	M.J.H.
B	2011-05-18	#D140382 P9.0 REVISION: B (AHI REPLACED) #D140382 P10.0 REVISION: B (AHI REPLACED) #C-1889 VIP PRODUCTION VEHICLE	P9.0 & 9.1 P10.0 & 10.1	R.LAM.	M.J.H.	M.J.H.
C	2011-10-27	#D140382 P1.0 REVISION: B (New I.F.S. 19,000 lbs) Preliminary Vehicle #C-1880, Production Vehicle #C-1910...	P1.0 1.1 a 1.4	Rob.	M.J.H.	M.J.H.
D	2011-11-04	#D140382 P7.0 REVISION: B (update) VOLVO ENGINE VERSION WITHOUT DRV VALVE Production vehicle #C-1995...	P7.0 & 7.1 P.9 & 10 P9.1&10.1	Rob. Rob.	M.J.H. M.Pelletier	M.J.H. M.Pelletier

Pneumatic diagram

PNEUMATIC DIAGRAMS VIP BUS SHELL WITH INDEPENDENT SUSPENSION SYSTEM

PRODUCTION NUMBER	REV	EFF. VEH.	ECN	S.A.V. NUMBER	REV	DESCRIPTION
D140382P1.0	B	#C-1910...	2010070	D140382P1.1	B	FULL PNEUMATIC ABS 6 AIR BRAKE SYSTEM (WITH STD LEVEL-LOW FINGER TIP SUSPENSION)
				D140382P1.2	B	ACCESSORIES
				D140382P1.3	B	BRAKES SYSTEM
				D140382P1.4	B	SUSPENSION
D140382P2.0	A	#B-1772	2010001	D140382P2.1	A	AIR BRAKE SYSTEM ESP OPTION
D140382P3.0	A	#B-1772	2010001	D140382P3.1	A	AIR BRAKE SYSTEM ESP OPTION WITH AIR BRAKE ON TRAILER HITCH OPTION.
D140382P4.0	A	#B-1772	2010001	D140382P4.1	A	WITH FRONT SINGLE SLIDE OUT OPTION, LEFT SIDE
D140382P5.0	A	#B-1772	2010001	D140382P5.1	A	WITH DOUBLE SLIDE OUT LEFT SIDE, FRONT AND REAR. SMALL OR LARGE SIZE REAR CAISSON POSSIBILITY OPTION.
D140382P6.0	A	#B-1772	2010001	D140382P6.1	A	WITH TRIPLICATE SLIDE OUT , LEFT SIDE FRONT AND REAR , RIGHT SIDE REAR. SMALL OR LARGE SIZE REAR CAISSON POSSIBILITY OPTION
D140382P7.0	B	#B-1772	2010001	D140382P7.1	B	WITH TRIPLICATE SLIDE OUT, LEFT SIDE FRONT AND REAR , RIGHT SIDE FRONT. SMALL OR LARGE SIZE REAR CAISSON POSSIBILITY OPTION
D140382P8.0	A	#B-1772	2010001	D140382P8.1	A	WITH QUADRUPLE SLIDE OUT, LEFT SIDE FRONT AND REAR , RIGHT SIDE FRONT AND REAR. SMALL OR LARGE SIZE REAR CAISSON POSSIBILITY OPTION
D140382P9.0	C	#C-1995	2011095	D140382P9.1	C	WITH ENGINE D13 VOLVO AND TRANSMISSION WORLD WITHOUT OUTPUT RETARDER
D140382P10.0	C	#C-1995	2011095	D140382P10.1	C	WITH ENGINE D13 VOLVO AND TRANSMISSION WORLD WITH OUTPUT RETARDER
D140382SP1.0	A	#B-1772	2010001	D140382SP1.1	A	"SPECIAL" WITH EXTRA AIR TANK ADDED TO FRONT SUSPENSION
D140382SP2.0	A	#B-1772	2010001	D140382SP2.1	A	"SPECIAL" WITH AIR HORN ADDED

TUBE COLOR CODING		
ACTIVE	COLOR	CIRCUIT
---	RED	SECONDARY
---	GREEN	PRIMARY & SUPPLY
---	YELLOW	PARKING BRAKES
---	BLUE	STANDARD SUSPENSION
---	BLACK	ACCESSORIES

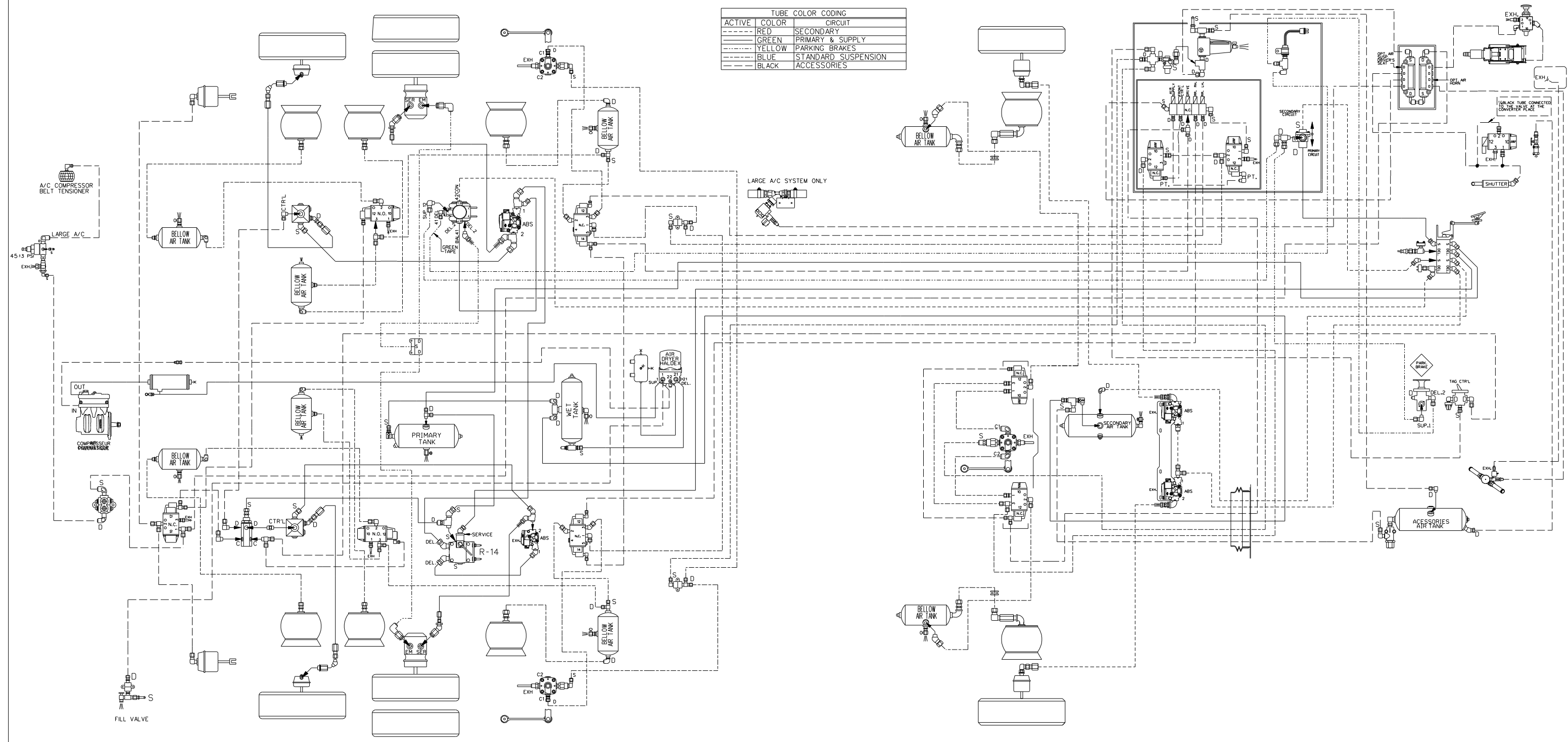

PREVOST®

DESCRIPTION: VIP
WITH INDEPENDENT SUSPENSION SYSTEM
-FULL PNEUMATIC ABS 6 SYSTEM-

REV.: A
DATE: 2010/09

PAGE: D140382 P.1

TUBE COLOR CODING	
ACTIVE COLOR	CIRCUIT
RED	SECONDARY
GREEN	PRIMARY & SUPPLY
YELLOW	PARKING BRAKES
BLUE	STANDARD SUSPENSION
BLACK	ACCESSORIES

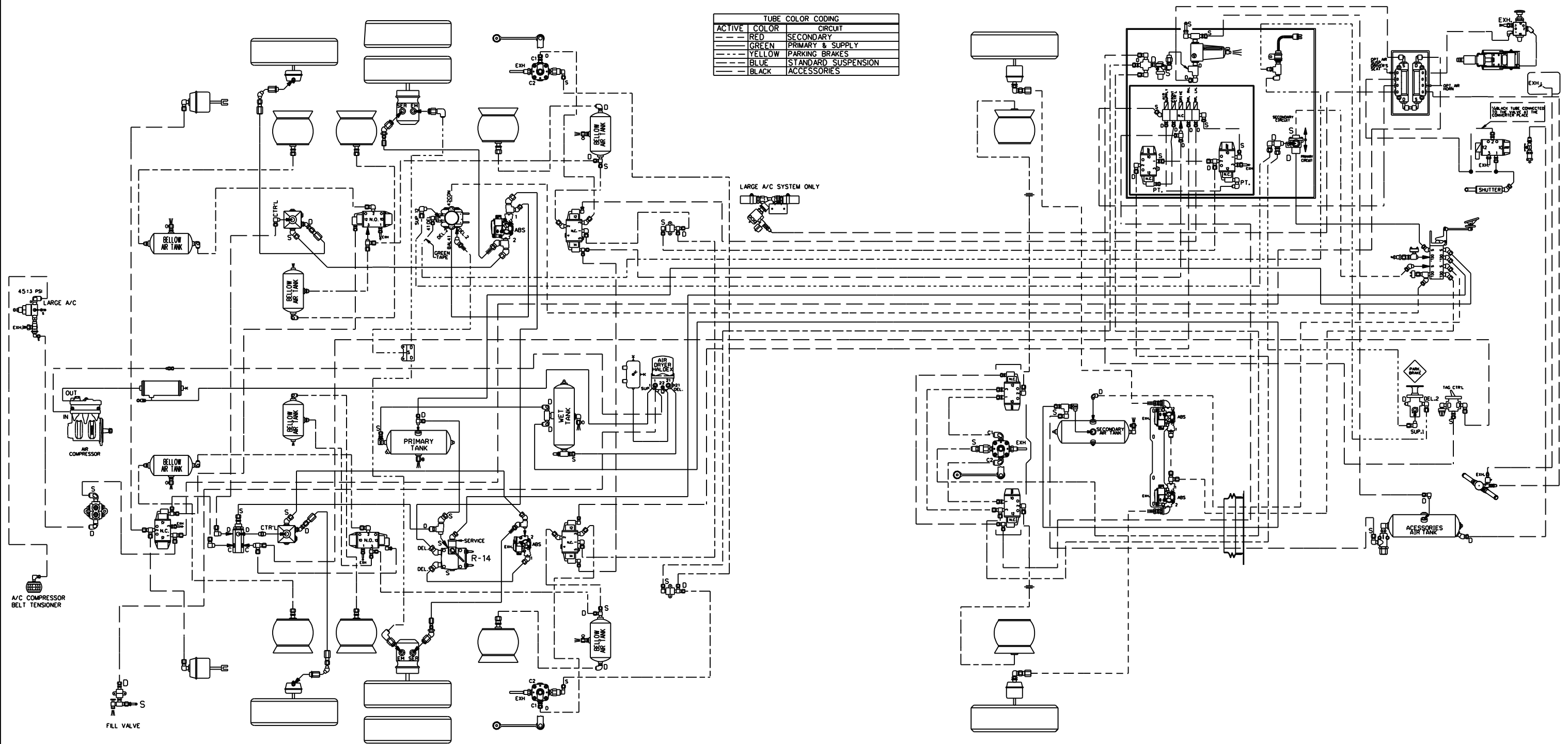

PREVOST®

DESCRIPTION:

VIP
WITH INDEPENDENT SUSPENSION SYSTEM
-FULL PNEUMATIC ABS 6 SYSTEM-

REV.:

B

PAGE:

D140382 P1.1

DATE:

2011/10

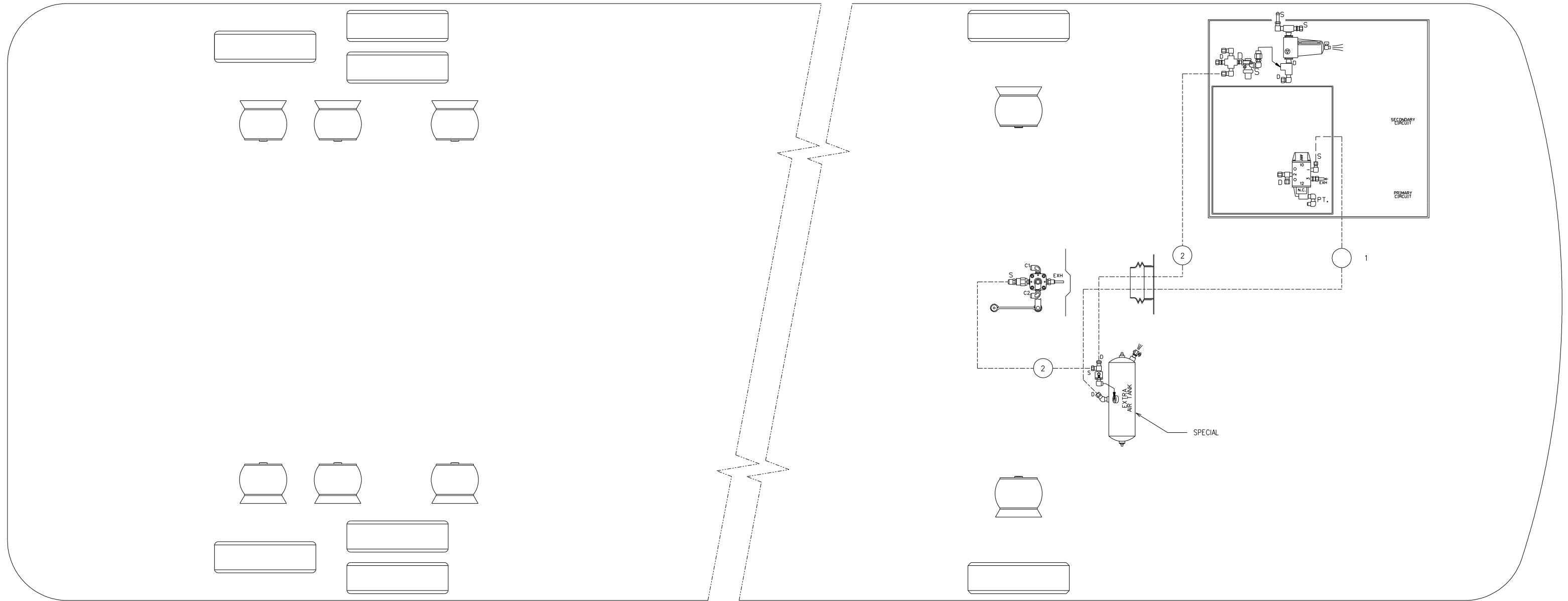

TUBE COLOR CODING		
ACTIVE	COLOR	CIRCUIT
----	BLACK	ACCESSORIES
-----	BLUE	SUSPENSION

BALLOON	PIPE
#1	1/2" O.D. BLUE
#2	3/8" O.D. BLUE

PREVOST®

DESCRIPTION:

VIP, WITH INDEPENDENT SUSPENSION SYSTEM
SPECIAL WITH EXTRA AIR TANK ADDED TO
FRONT SUSPENSION

REV.:

A

DATE:

2010/09

PAGE:

D140382 SP1.1

TUBE COLOR CODING		
ACTIVE	COLOR	CIRCUIT
---	BLACK	ACCESSORIES

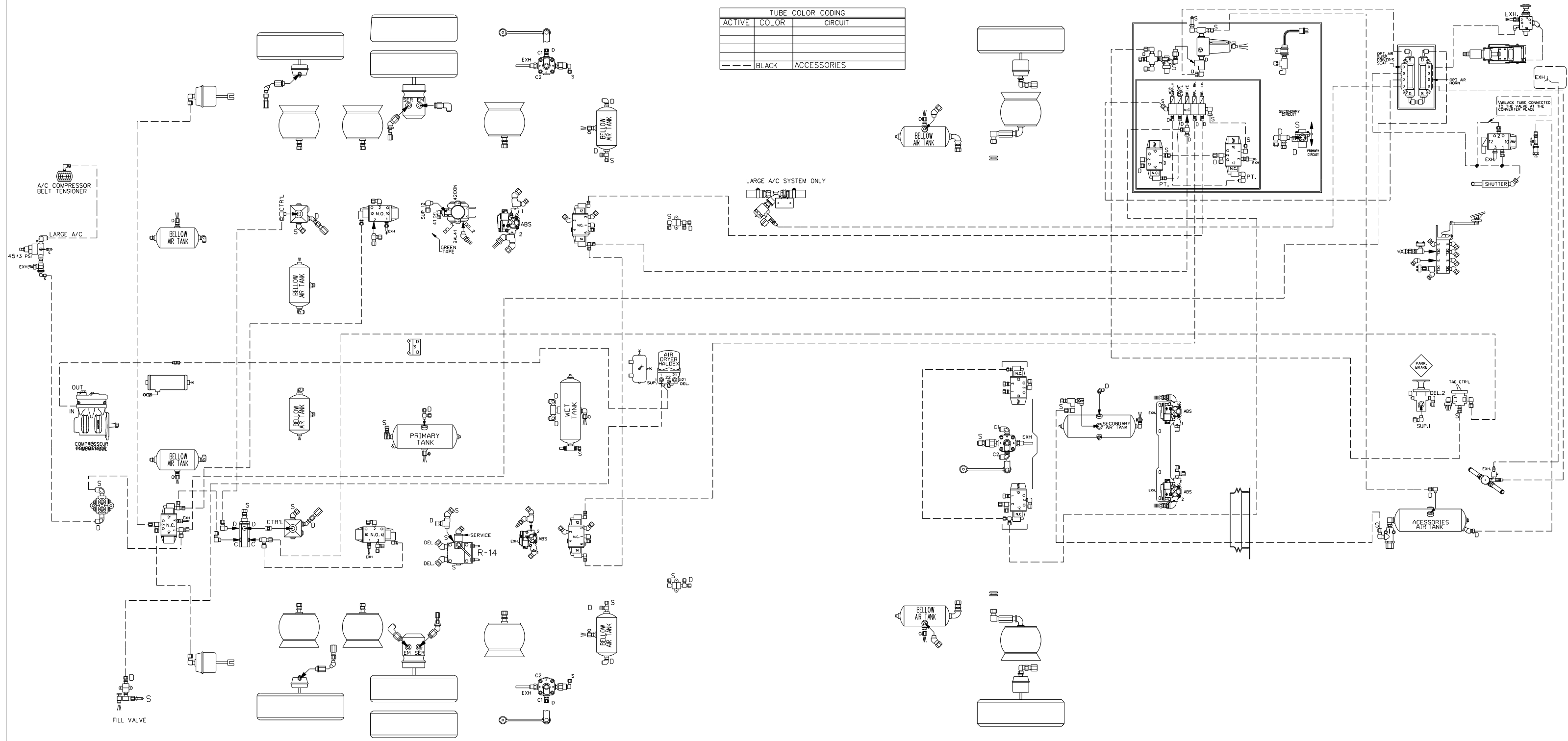

TUBE COLOR CODING		
ACTIVE	COLOR	CIRCUIT
— BLACK ACCESSORIES		

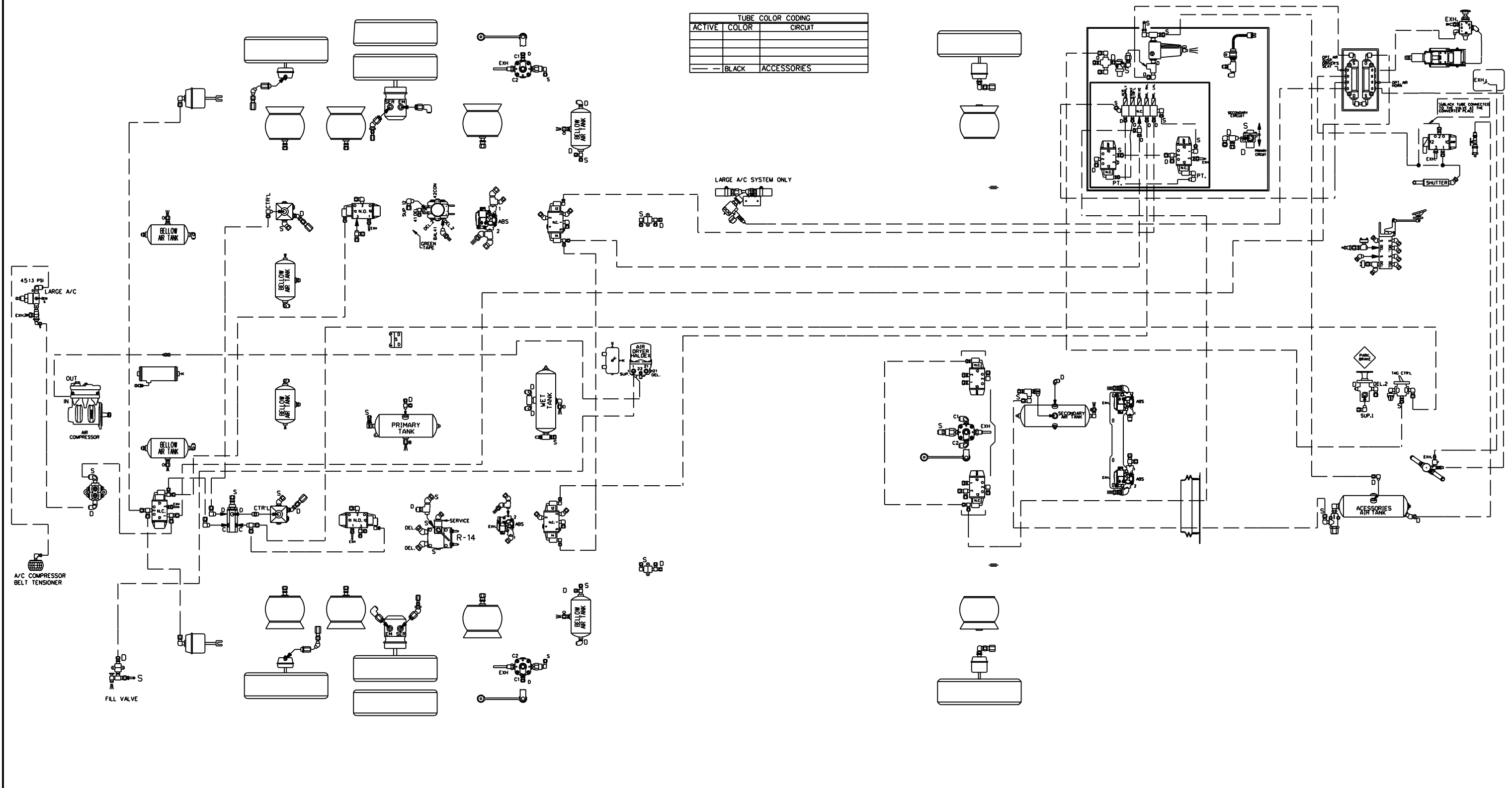

TUBE COLOR CODING		
ACTIVE	COLOR	CIRCUIT
---	RED	SECONDARY
---	GREEN	PRIMARY & SUPPLY
---	YELLOW	PARKING BRAKES

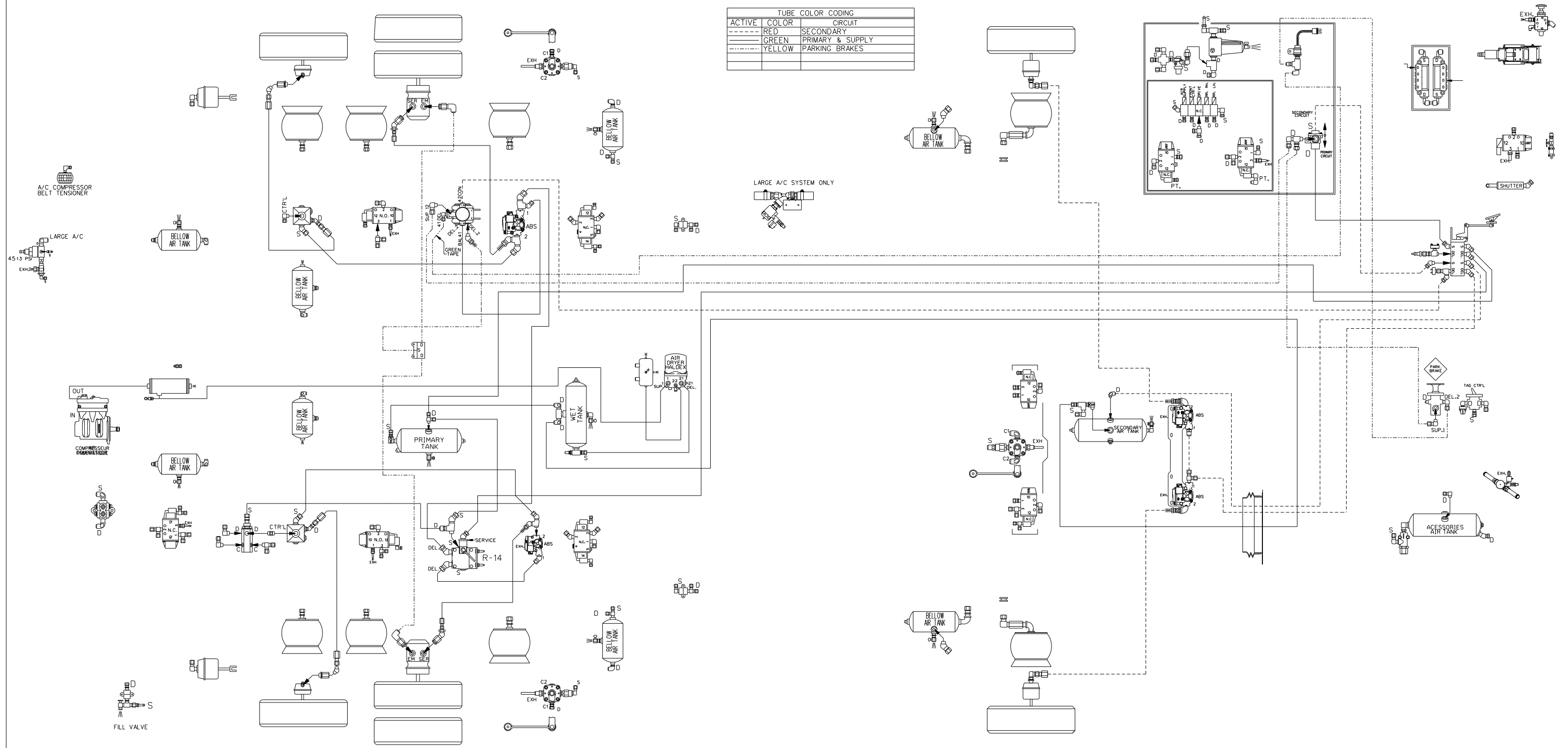

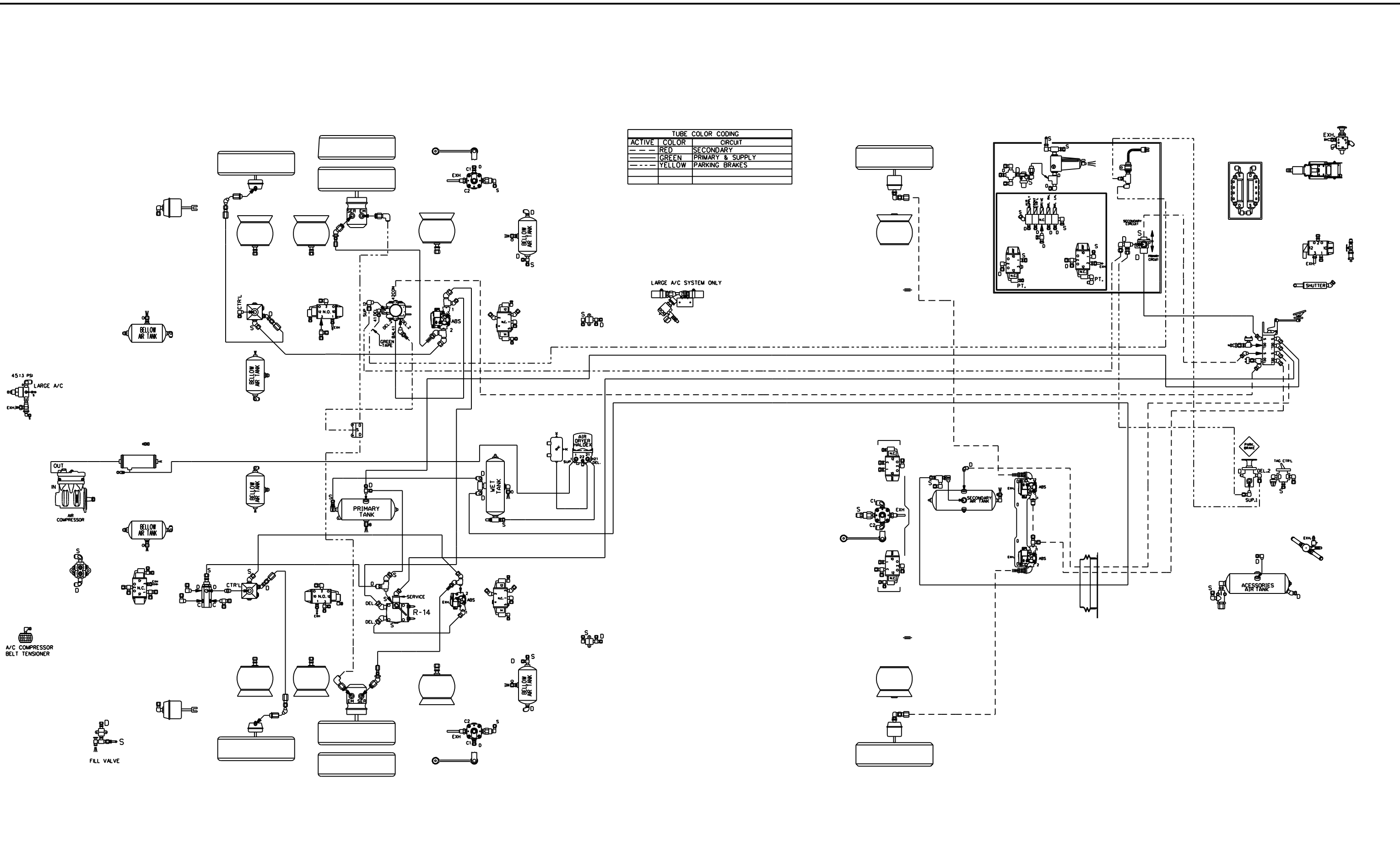

TUBE COLOR CODING		
ACTIVE	COLOR	CIRCUIT
---	BLUE	STANDARD SUSPENSION

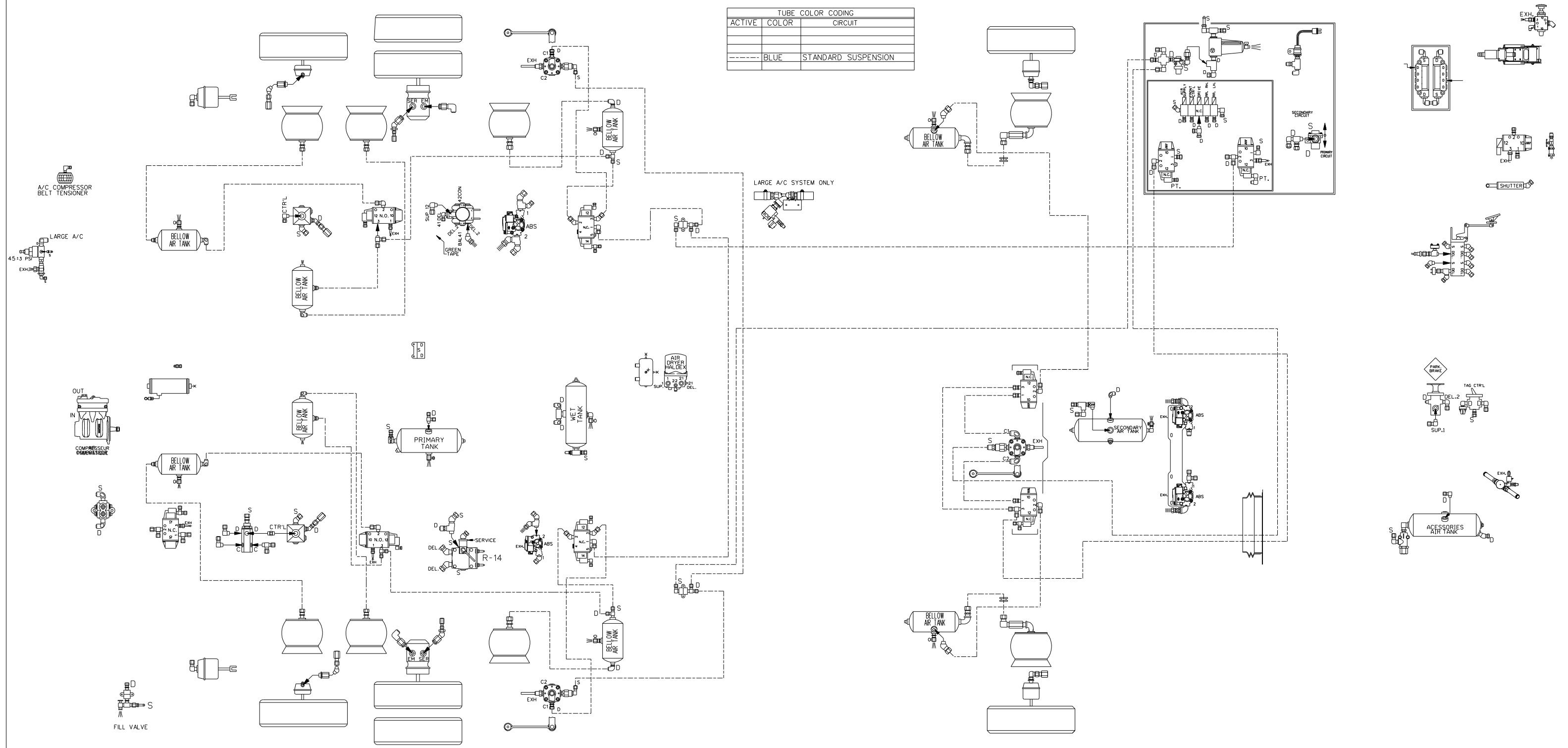

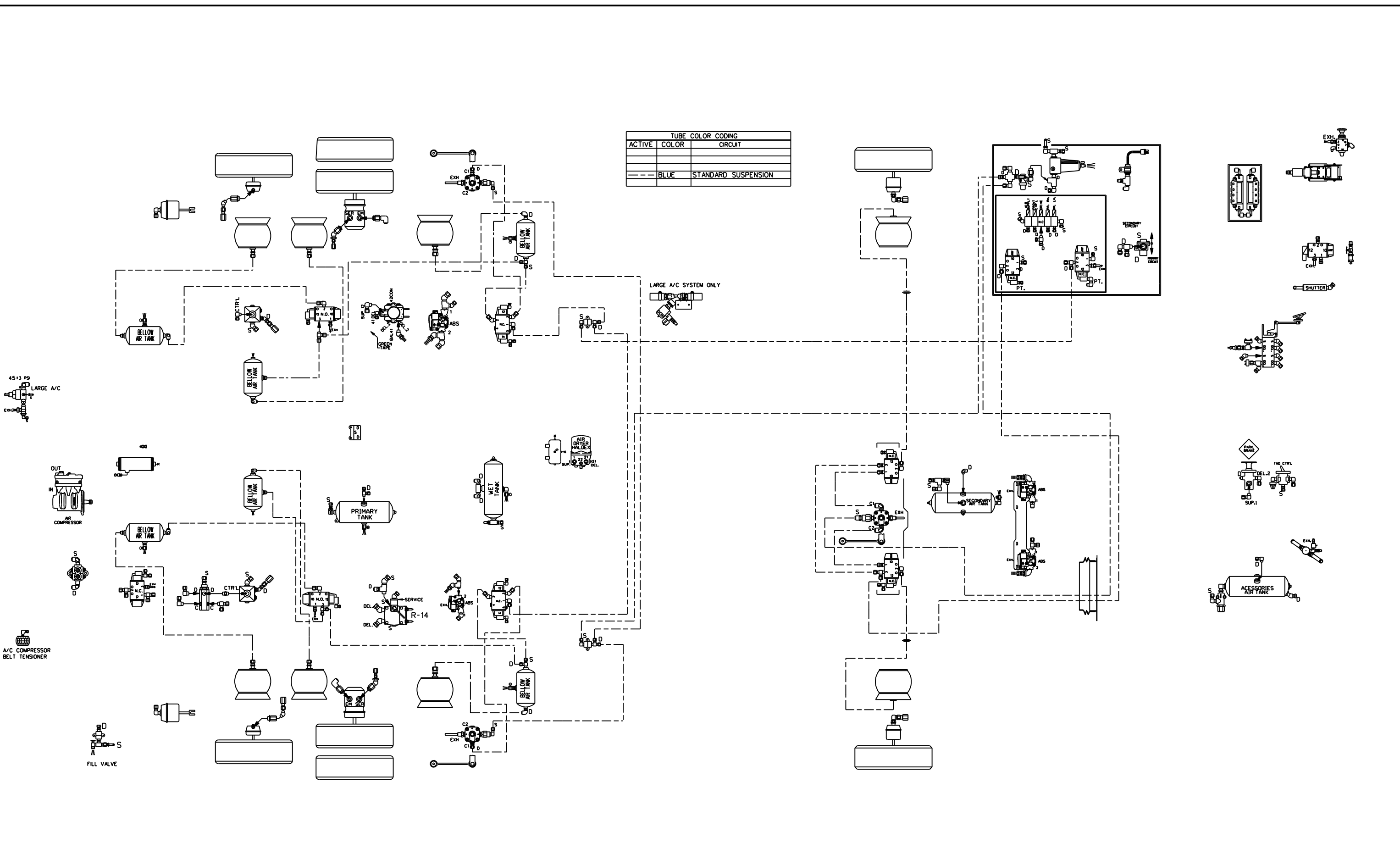

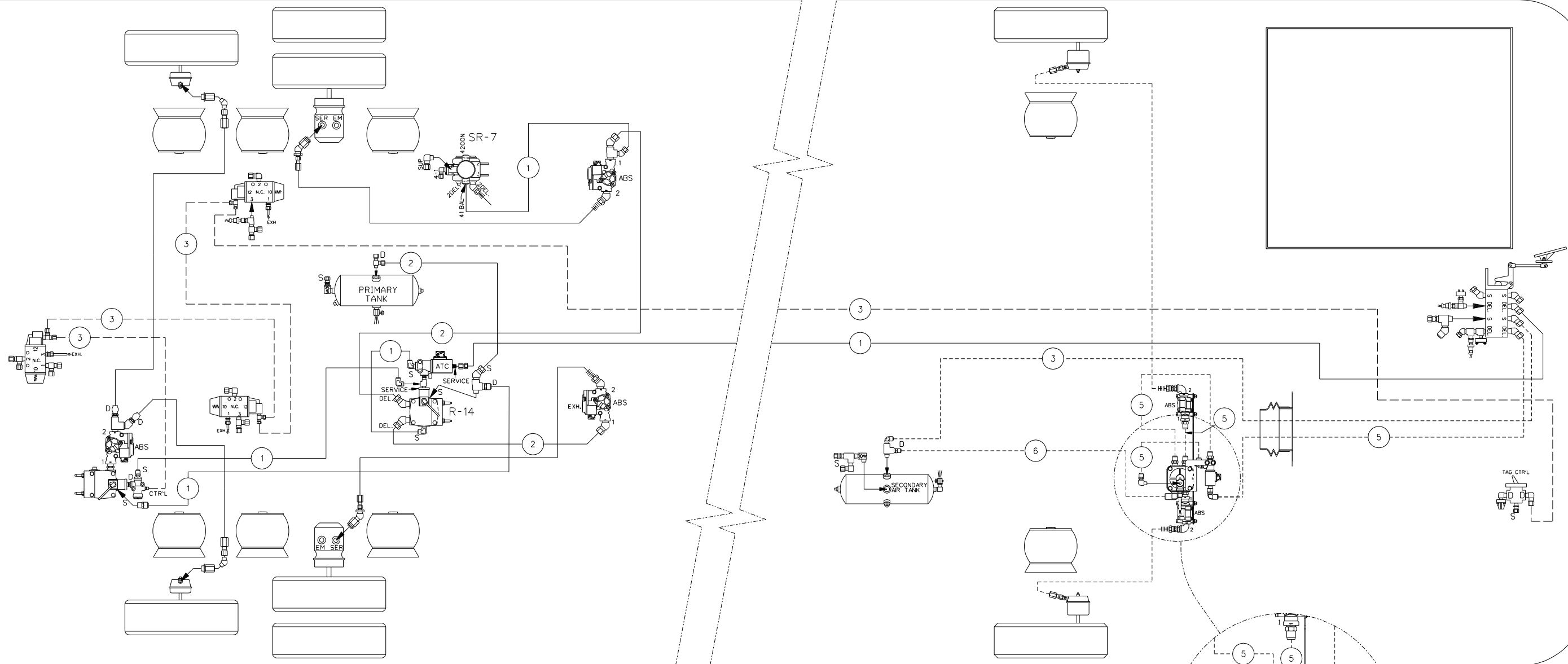

TUBE COLOR CODING		
ACTIVE	COLOR	CIRCUIT
—	GREEN	PRIMARY & SUPPLY
- - -	BLACK	ACCESSORIES
- - - -	RED	SECONDARY

BALLOON	PIPE
#1	3/8" O.D. GREEN
#2	5/8" O.D. GREEN
#3	1/4" O.D. BLACK
#4	3/8" O.D. RED
#5	1/2" O.D. RED
#6	5/8" O.D. RED

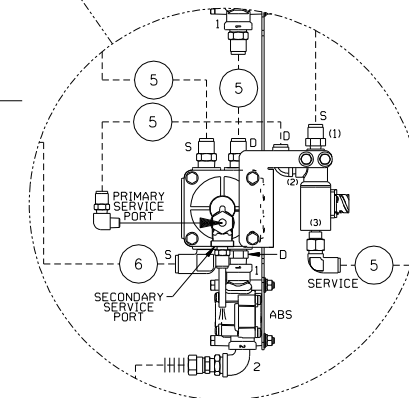

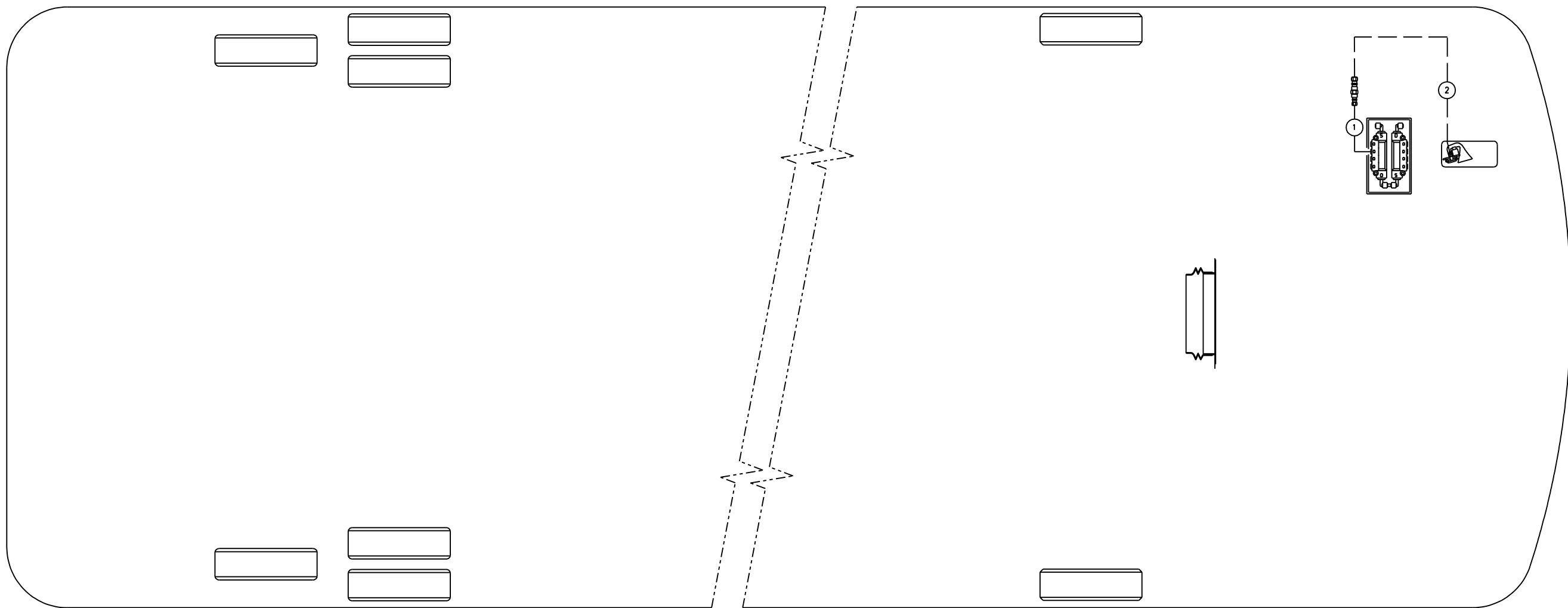

TUBE COLOR CODING		
ACTIVE	COLOR	CIRCUIT
---	BLACK	ACCESSORIES

BALLOON	PIPE
*1	1/4" O.D. BLACK
*2	1/8" O.D. BLACK

PREVOST®

DESCRIPTION:

VIP,
WITH INDEPENDENT SUSPENSION SYSTEM
SPECIAL WITH AIR HORN ADDED

REV.: A
DATE: 2010/09

PAGE:
D140382 SP2.1

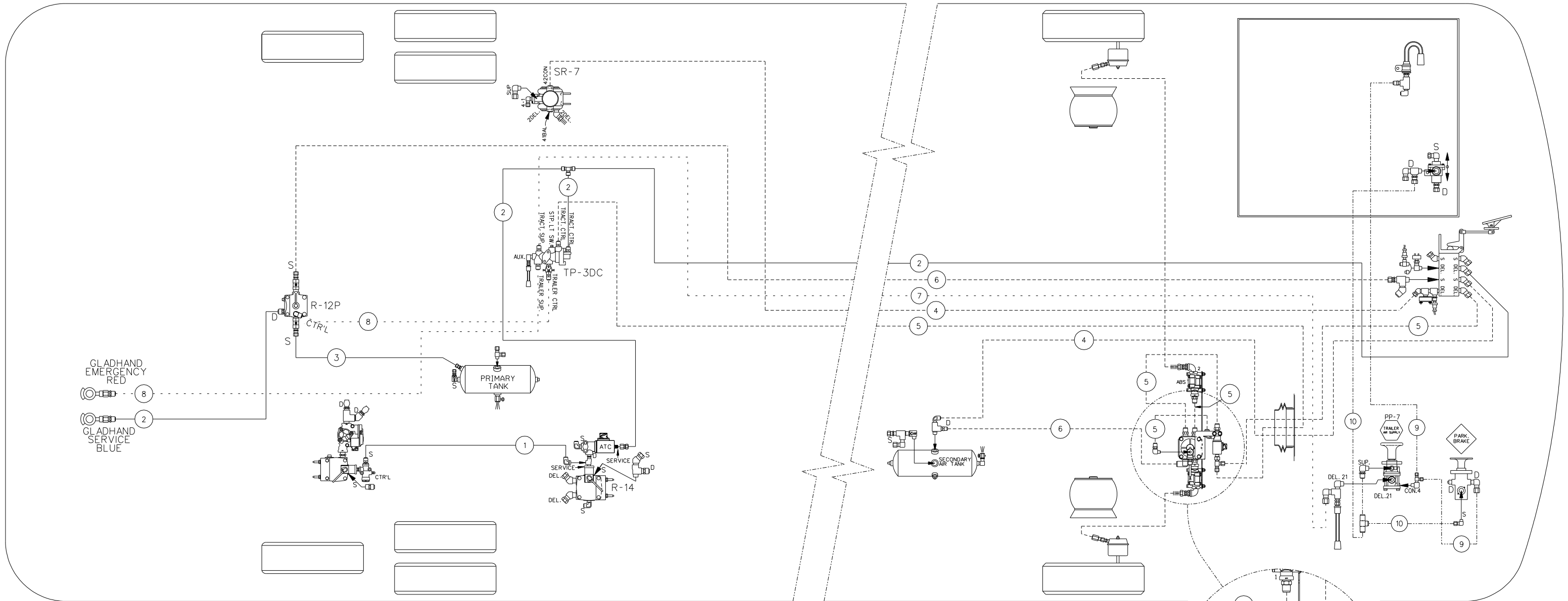

GLADHAND
EMERGENCY
RED

GLADHAND
SERVICE
BLUE

BALLOON	PIPE
#1	3/8" O.D. GREEN
#2	1/2" O.D. GREEN
#3	5/8" O.D. GREEN
#4	3/8" O.D. RED
#5	1/2" O.D. RED
#6	5/8" O.D. RED
#7	3/8" O.D. BROWN
#8	1/2" O.D. BROWN
#9	1/4" O.D. YELLOW
#10	3/8" O.D. YELLOW

TUBE COLOR CODING	
ACTIVE COLOR	CIRCUIT
---	RED SECONDARY
---	GREEN PRIMARY & SUPPLY
---	YELLOW PARKING BRAKE
---	BLACK ACCESSORIES
---	BROWN TRAILER

PREVOST®

DESCRIPTION: VIP,
WITH INDEPENDENT SUSPENSION SYSTEM
WITH AIR BRAKES TRAILER HITCH &
ESP OPTIONS

REV.: A
DATE: 2010/09

PAGE: D140382 P3.1

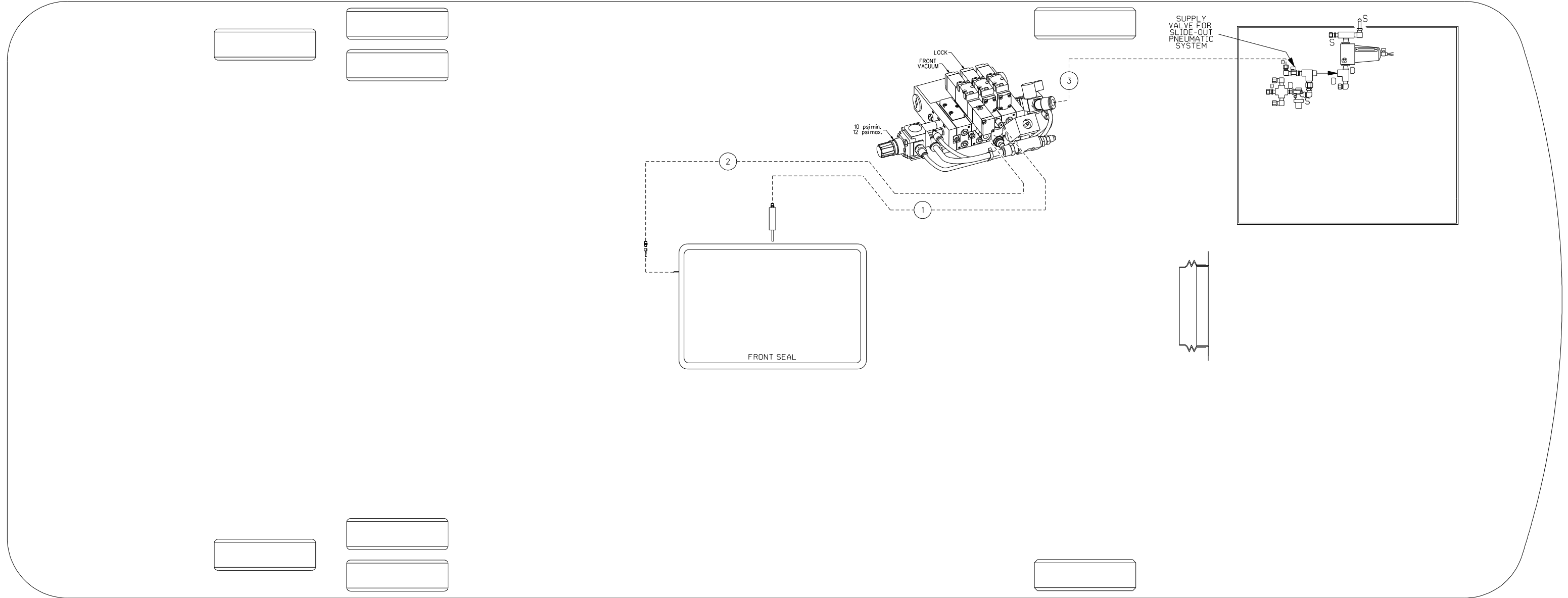

TUBE COLOR CODING		
ACTIVE	COLOR	CIRCUIT
---	BLACK	ACCESSORIES

BALLOON	PIPE
#1	1/8" O.D. BLACK
#2	3/8" O.D. BLACK
#3	1/2" O.D. BLACK

PREVOST®

DESCRIPTION:

VIP,
WITH INDEPENDENT SUSPENSION SYSTEM
FRONT SINGLE SLIDE-OUT OPTION, LEFT SIDE

REV.:

A

DATE:

2010/09

PAGE:

D140382 P4.1

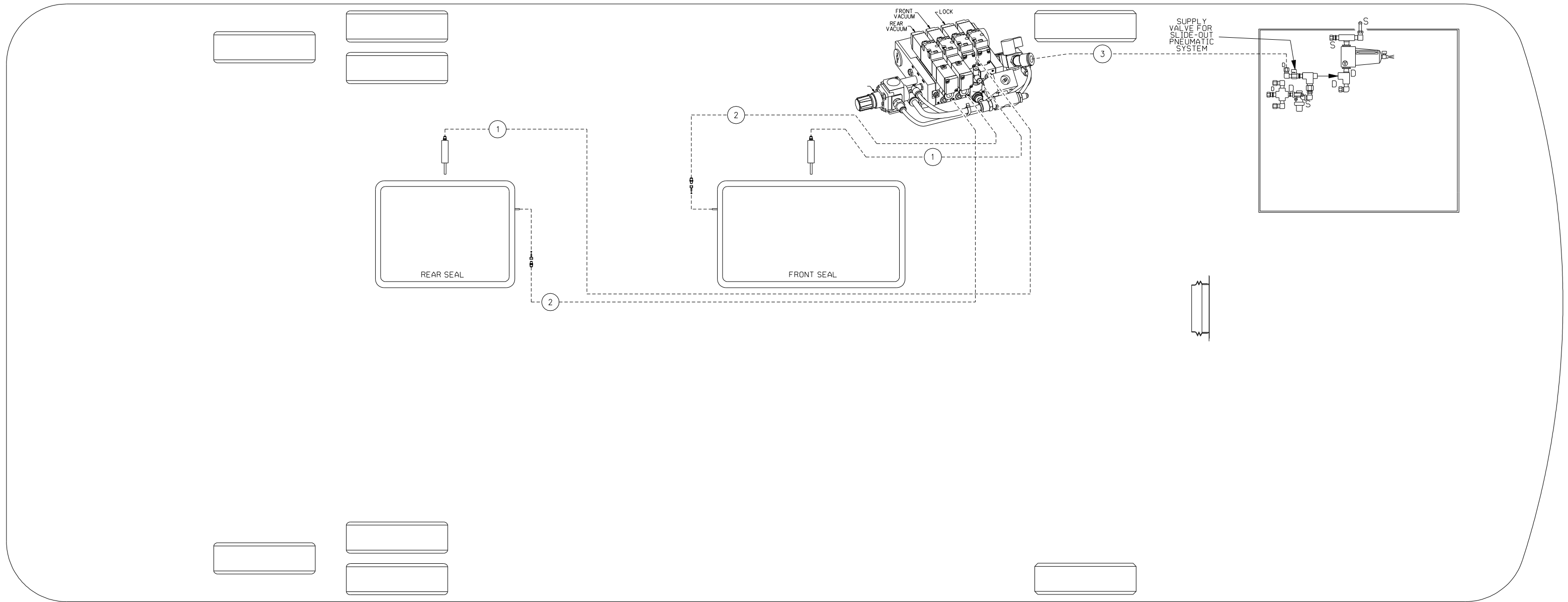

TUBE COLOR CODING		
ACTIVE	COLOR	CIRCUIT
---	BLACK	ACCESSORIES

BALLOON	PIPE
#1	1/8" O.D. BLACK
#2	3/8" O.D. BLACK
#3	1/2" O.D. BLACK

PREVOST®

DESCRIPTION:

VIP, WITH INDEPENDENT SUSPENSION SYSTEM
 DOUBLE SLIDE-OUT OPTION LEFT SIDE, FRONT AND REAR
 SMALL OR LARGE REAR CAISSON POSSIBILITY OPTION

REV.: A
 DATE: 2010/09

PAGE: D140382 P5.1

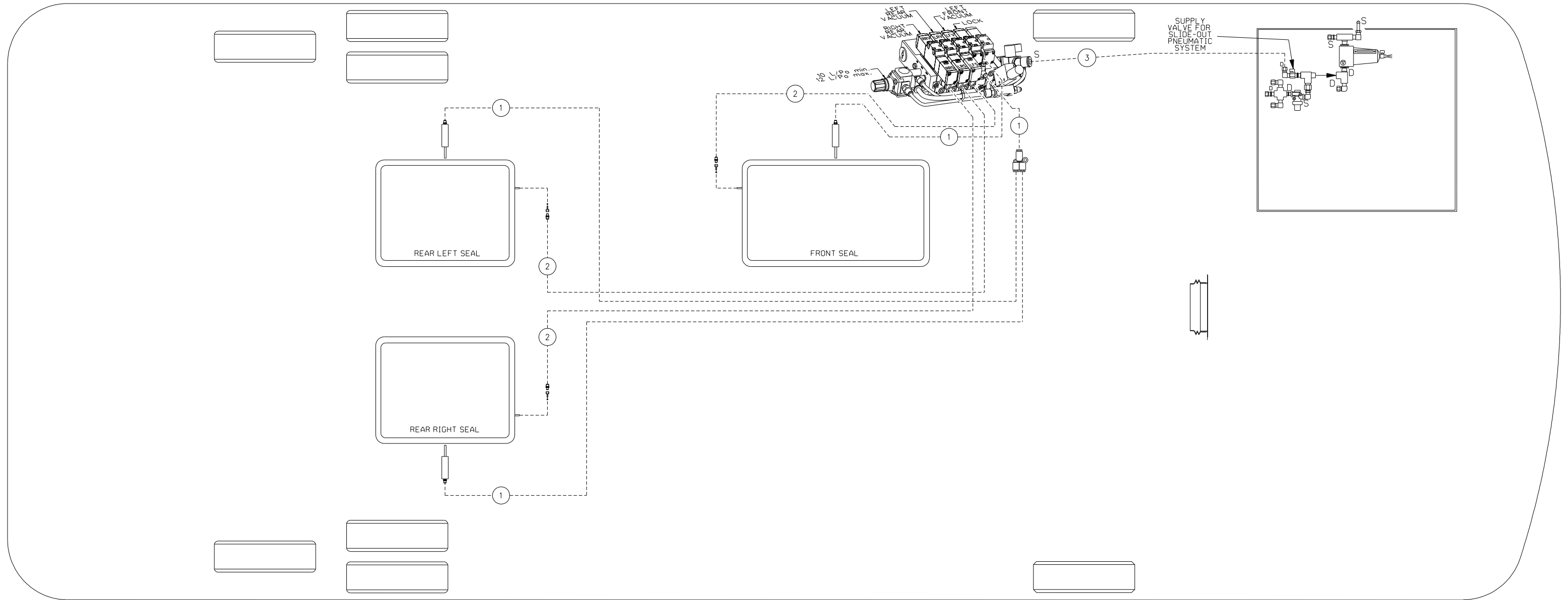

TUBE COLOR CODING		
ACTIVE	COLOR	CIRCUIT
---	BLACK	ACCESSORIES

BALLOON	PIPE
#1	1/8" O.D. BLACK
#2	3/8" O.D. BLACK
#3	1/2" O.D. BLACK

PREVOST®

DESCRIPTION: VIP, WITH INDEPENDENT SUSPENSION SYSTEM TRIPPLICATE
 SLIDE-OUT OPTION LEFT SIDE, FRONT AND REAR
 RIGHT SIDE REAR ONLY SMALL OR LARGE REAR CAISSON
 POSIBILITY OPTION

REV.: A
 DATE: 2010/09

PAGE: D140382 P6.1

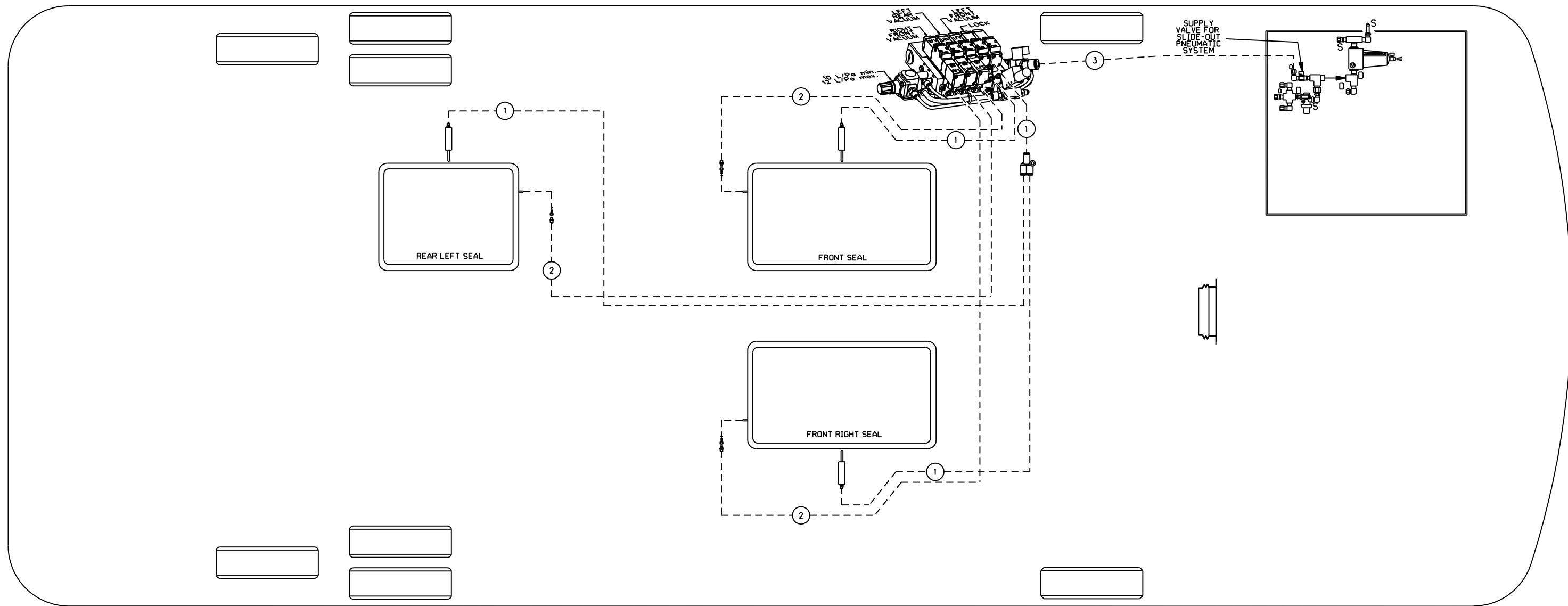

TUBE COLOR CODING	
ACTIVE COLOR	CIRCUIT
— BLACK	ACCESSORIES

BALLOON	PIPE
*1	1/8" O.D. BLACK
*2	3/8" O.D. BLACK
*3	1/2" O.D. BLACK

PREVOST®

DESCRIPTION:

VIP, WITH INDEPENDENT SUSPENSION SYSTEM
 TRIPPLICATE SLIDE-OUT OPTION LEFT SIDE FRONT AND REAR &
 RIGHT SIDE FRONT ONLY. SMALL OR LARGE REAR AND FRONT
 RIGHT CAISSON POSSIBILITY OPTION

REV.:

B

PAGE:

D140382 P7.1

DATE:

2011/10

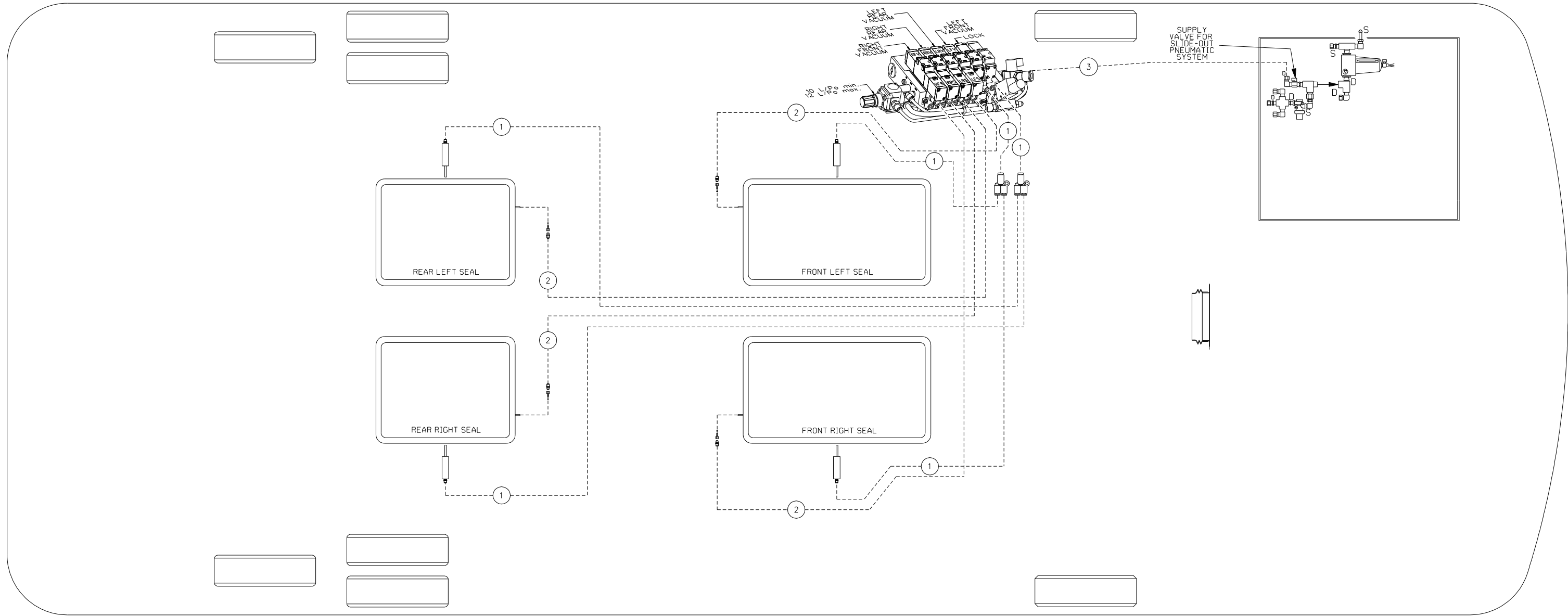

TUBE COLOR CODING	
ACTIVE COLOR	CIRCUIT
----- BLACK	ACCESSORIES

BALLOON	PIPE
#1	1/8" O.D. BLACK
#2	3/8" O.D. BLACK
#3	1/2" O.D. BLACK

PREVOST®

DESCRIPTION:
 VIP WITH INDEPEDENT SUSPENSION SYSTEM, FOUR SLIDE-OUT OPTION
 SMALL OR LARGE REAR AND RIGHT FRONT CAISSON POSSIBILITY
 OPTIONS

REV.: A
 DATE: 2010/09

PAGE:
 D140382 P8.1

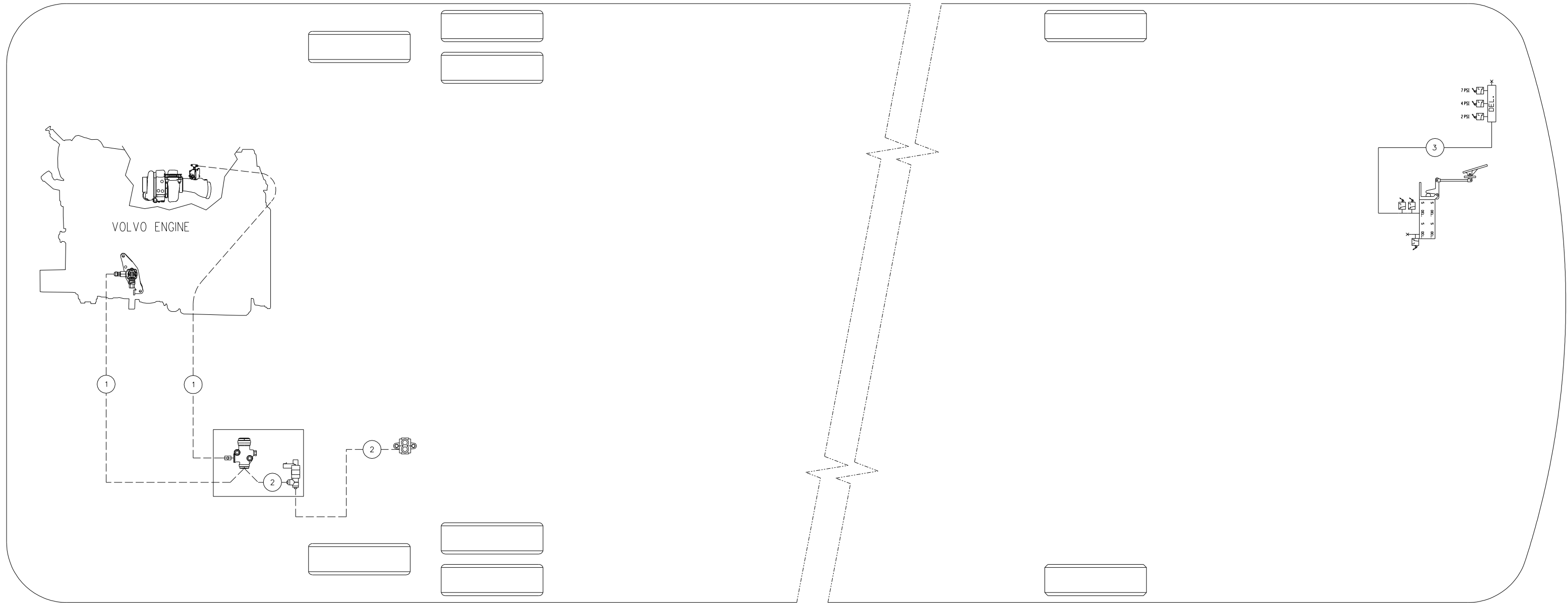

TUBE COLOR CODING		
ACTIVE	COLOR	CIRCUIT
-----	BLACK	ACCESSORIES
—————	GREEN	PRIMARY & SUPPLY

BALLOON	PIPE
#1	HOSE ASS'Y
#2	1/4" O.D. BLACK
#3	3/8" O.D. GREEN

PREVOST®

DESCRIPTION:

VIP,
WITH INDEPENDENT SUSPENSION SYSTEM
WITHOUT OUTPUT RETARDER ON WORLD TRANSMISSION

REV.:

A

DATE:

2010/09

PAGE:

D140382 P9.1

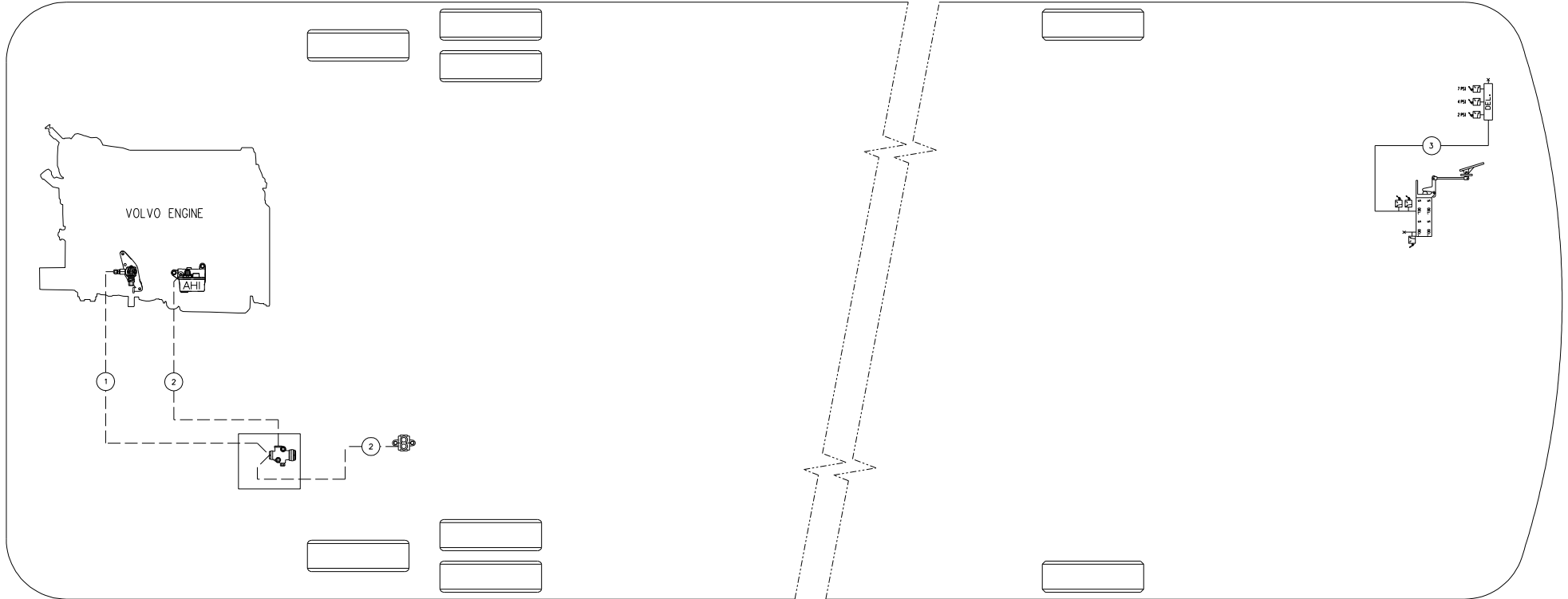

TUBE COLOR CODING		
ACTIVE	COLOR	CIRCUIT
---	BLACK	ACCESSORIES
---	GREEN	PRIMARY & SUPPLY

BALLOON	PIPE
*1	HOSE ASS'Y
*2	1/4" O.D. BLACK
*3	3/8" O.D. GREEN

PREVOST®

DESCRIPTION: VIP,
WITH INDEPENDENT SUSPENSION SYSTEM
WITHOUT OUTPUT RETARDER ON WORLD TRANSMISSION

REV.: B
DATE: 2011/02

PAGE: D140382 P9.1

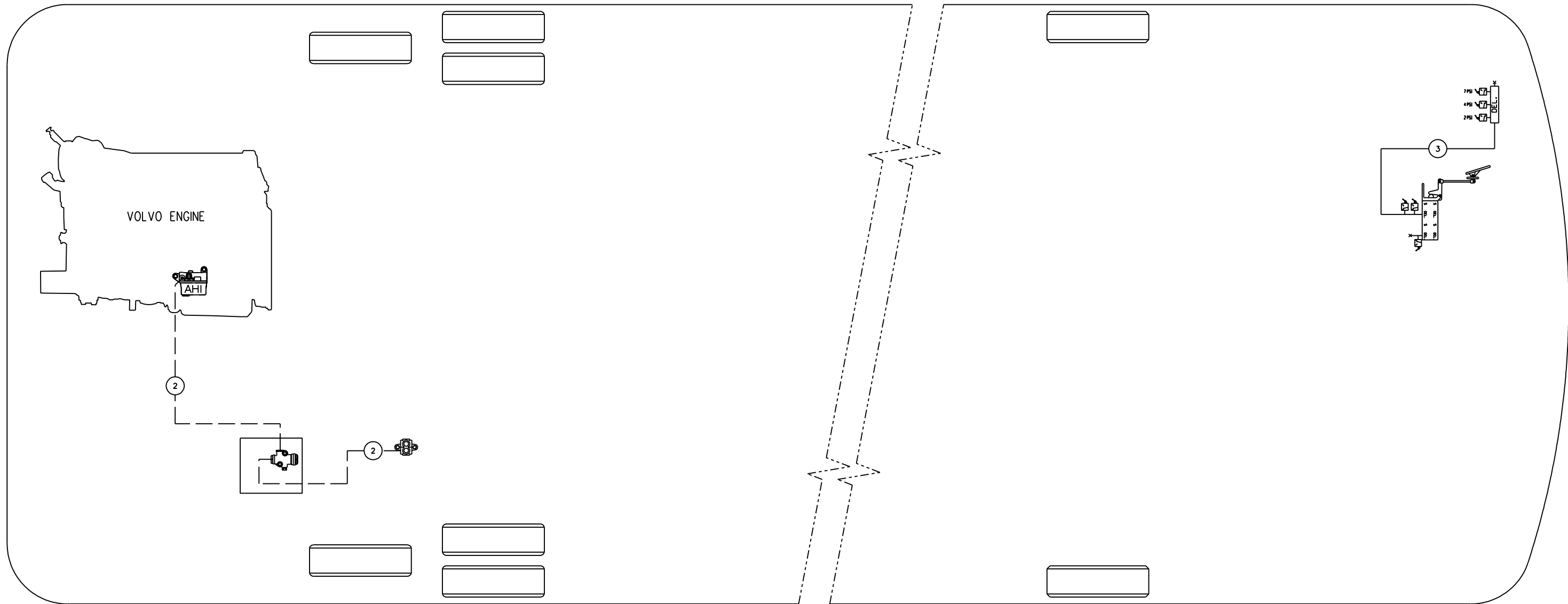

TUBE COLOR CODING		
ACTIVE	COLOR	CIRCUIT
---	BLACK	ACCESSORIES
---	GREEN	PRIMARY & SUPPLY

BALLOON	PIPE
*1	---
*2	1/4" O.D. BLACK
*3	3/8" O.D. GREEN

PREVOST®

DESCRIPTION:

VIP,
WITH INDEPENDENT SUSPENSION SYSTEM
WITHOUT OUTPUT RETARDER ON WORLD TRANSMISSION

REV.:

C

DATE:

2011/12

PAGE:

D140382 P9.1

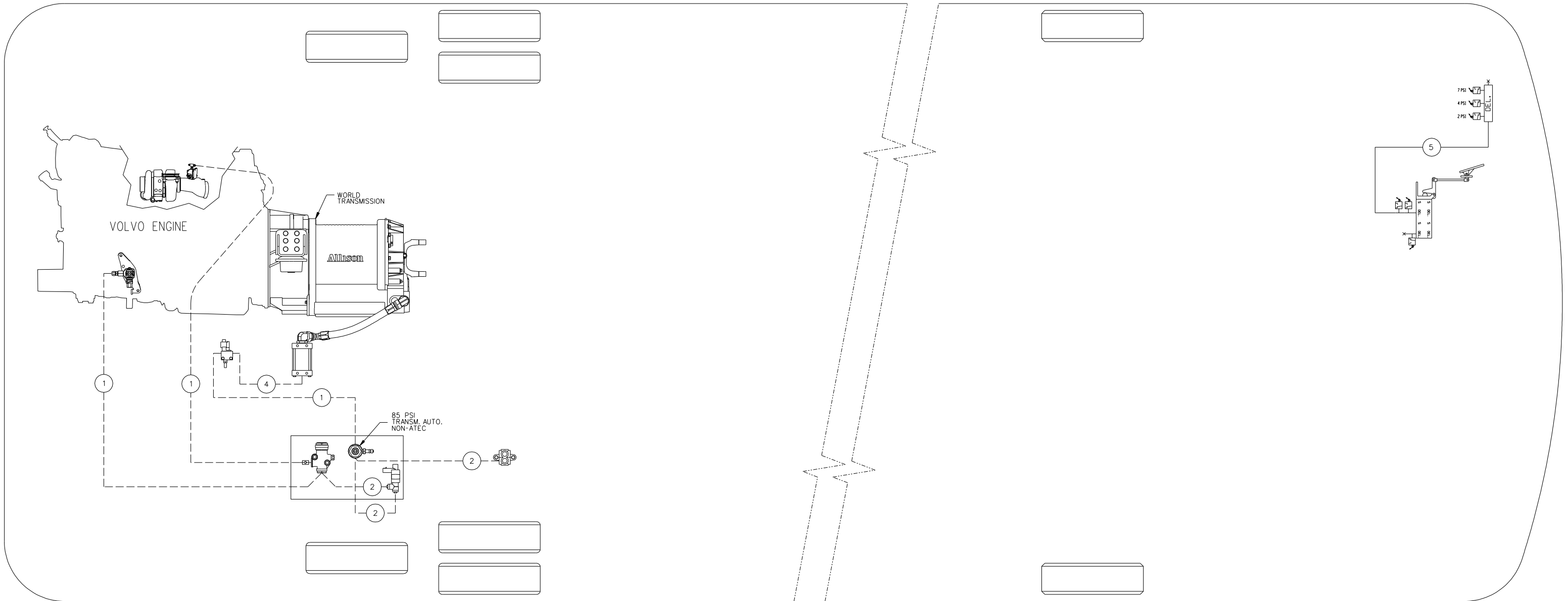

TUBE COLOR CODING		
ACTIVE	COLOR	CIRCUIT
----	BLACK	ACCESSORIES
—	GREEN	PRIMARY & SUPPLY

BALLOON	PIPE
#1	HOSE ASS'Y
#2	1/4" O.D. BLACK
#3	3/8" O.D. BLACK
#4	1/2" O.D. BLACK
#5	3/8" O.D. GREEN

PREVOST®

DESCRIPTION:

VIP,
WITH INDEPENDENT SUSPENSION SYSTEM
& OUTPUT RETARDER ON WORLD TRANSMISSION

REV.:

A

DATE:

2010/09

PAGE:

D140382 P10.1

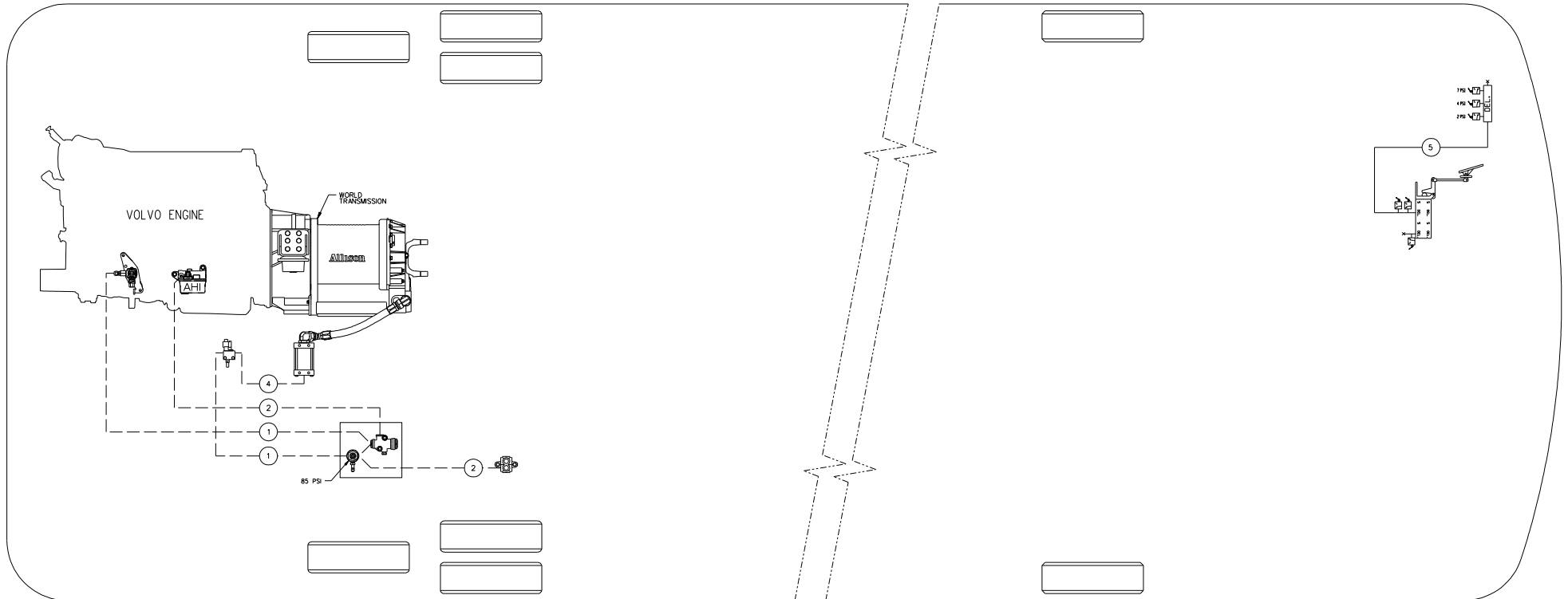

TUBE COLOR CODING		
ACTIVE	COLOR	CIRCUIT
---	BLACK	ACCESSORIES
---	GREEN	PRIMARY & SUPPLY

BALLOON	PIPE
*1	HOSE ASS'Y
*2	1/4" O.D. BLACK
*3	3/8" O.D. BLACK
*4	1/2" O.D. BLACK
*5	3/8" O.D. GREEN

PREVOST®

DESCRIPTION: VIP,
WITH INDEPENDENT SUSPENSION SYSTEM
& OUTPUT RETARDER ON WORLD TRANSMISSION

REV.: B
DATE: 2011/02

PAGE: D140382 P10.1

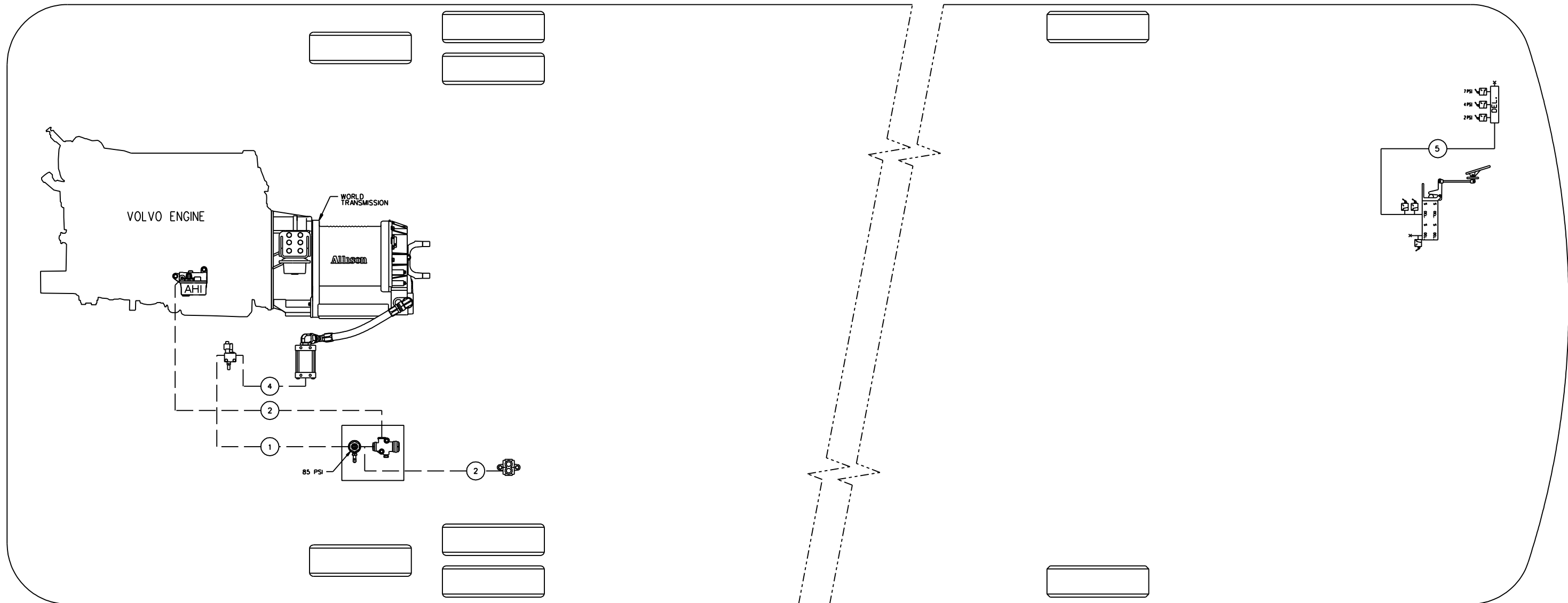

TUBE COLOR CODING		
ACTIVE	COLOR	CIRCUIT
---	BLACK	ACCESSORIES
---	GREEN	PRIMARY & SUPPLY

BALLOON	PIPE
*1	HOSE ASS'Y
*2	1/4" O.D. BLACK
*3	3/8" O.D. BLACK
*4	1/2" O.D. BLACK
*5	3/8" O.D. GREEN

PREVOST®

DESCRIPTION: VIP,
WITH INDEPENDENT SUSPENSION SYSTEM
& OUTPUT RETARDER ON WORLD TRANSMISSION

REV.: C
DATE: 2011/12

PAGE: D140382 P10.1