

DATE: 2003/02

D140301 P.1 REV.A
 XL2-45 COACH, ENGINE 2002
 WITH FRONT BEAM AXLE

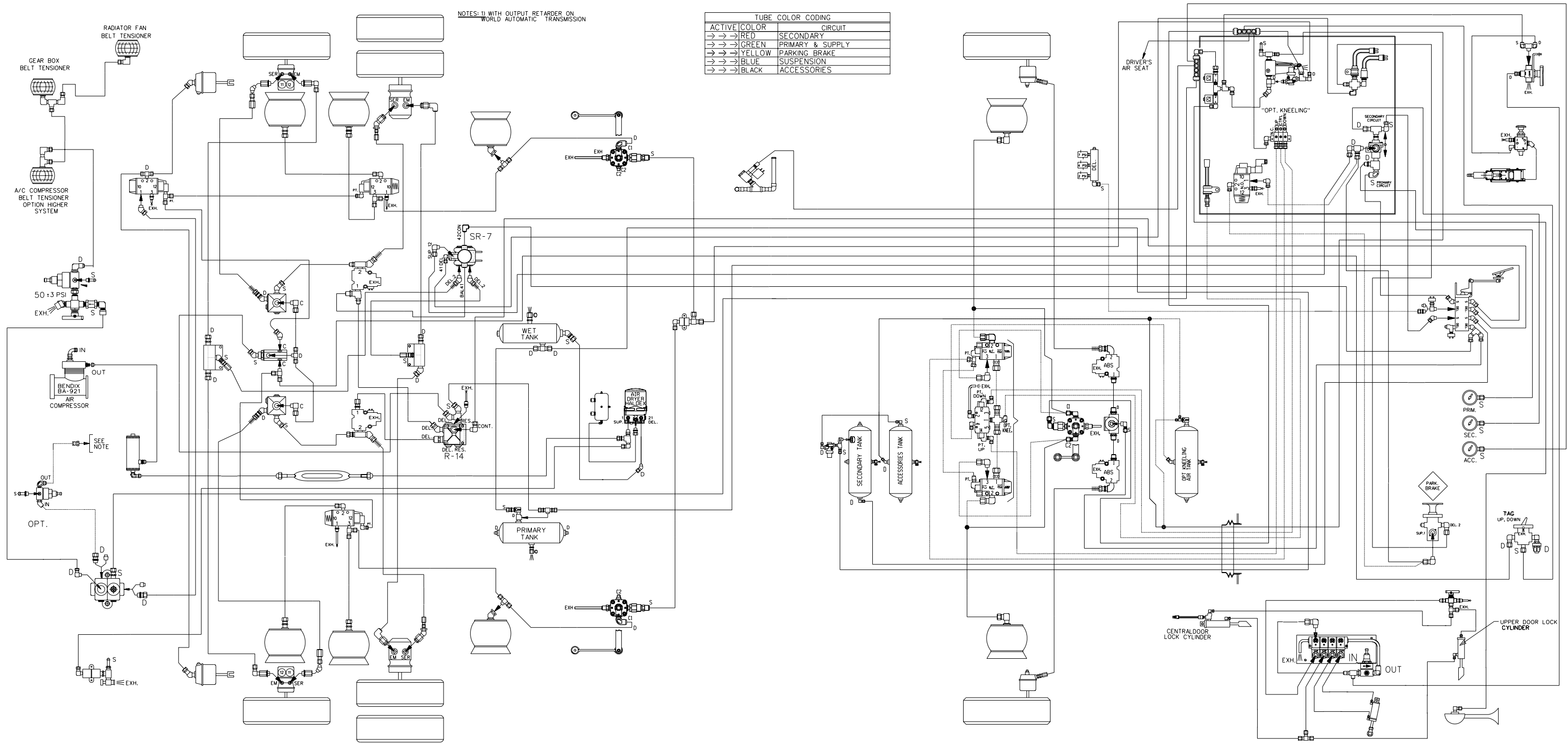

ACTIVE	COLOR	CIRCUIT
→→	RED	SECONDARY
→→	GREEN	PRIMARY & SUPPLY
→→	YELLOW	PARKING BRAKE
→→	BLUE	SUSPENSION
→→	BLACK	ACCESSORIES

DATE: 2004/01

D140301 P.1 REV.B
 XL2-45 COACH, ENGINE 2002
 WITH FRONT BEAM AXLE

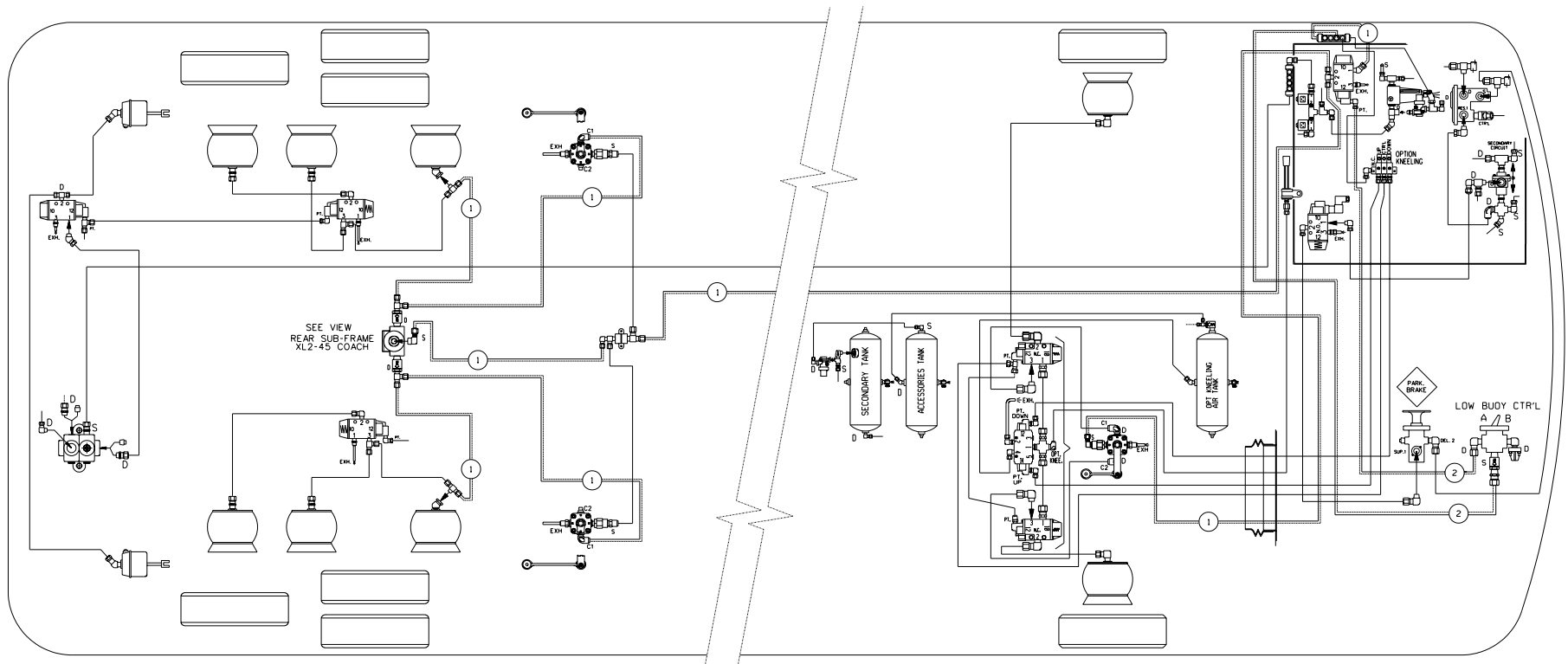

SEE VIEW
REAR SUB-FRAME
XL2-45 COACH

NOTE:

CONTROL VALVE OPT. "LOW-BUOY" , "A" OR "B" SETTING:

POSITION "A": VALVE IS OPEN,
AIR FLOW BETWEEN SUPPLY (S) AND
DELIVERY (D) , LOW-BUOY IS NOT IN FUNCTION.

POSITION "B": VALVE CLOSED,
AIR DOES'NT FLOW BETWEEN SUPPLY (S) AND
DELIVERY (D) , LOW-BUOY IS IN FUNCTION.

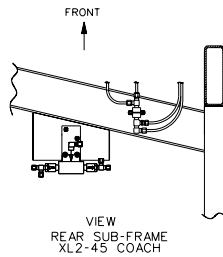

TUBE COLOR CODING	
ACTIVE COLOR	CIRCUIT
→ → RED	SECONDARY
→ → GREEN	PRIMARY & SUPPLY
→ → YELLOW	PARKING BRAKE
→ → BLUE	SUSPENSION
→ → BLACK	ACCESSORIES

BALLOON	PIPE
*1	3/8" O.D. BLUE
*2	1/4" O.D. BLACK
——	STD PIPING
——	OPTIONAL PIPING

XL2-45 COACH,
ENGINE 2002 WITH
FRONT BEAM AXLE
WITH OPTION FRONT KNEELING
& LOW-BUOY COMBINATION
D140301 P2 REV. A

DATE : 2003/02

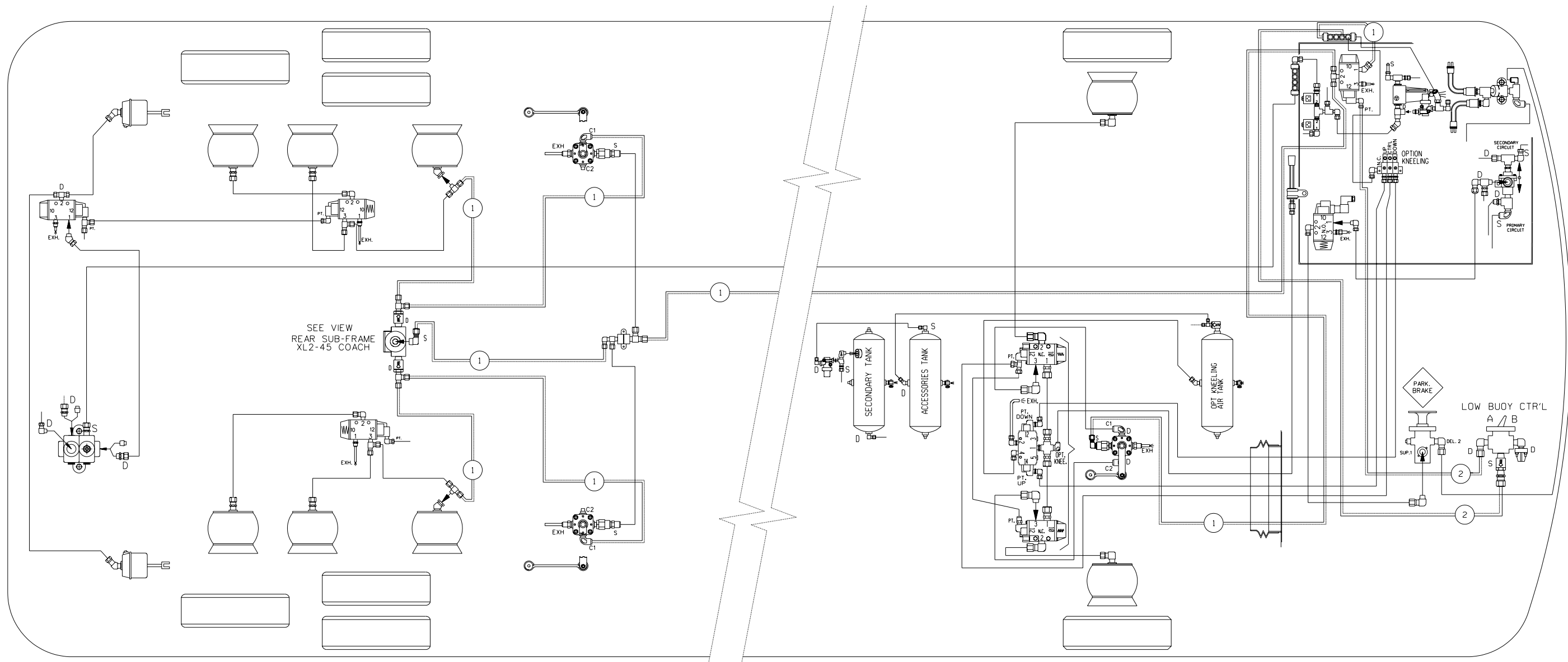

SEE VIEW
REAR SUB-FRAME
XL2-45 COACH

FRONT

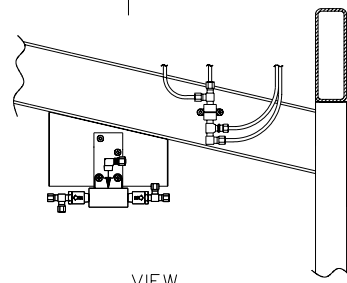

VIEW
REAR SUB-FRAME
XL2-45 COACH

TUBE COLOR CODING		
ACTIVE	COLOR	CIRCUIT
→→→	RED	SECONDARY
→→→	GREEN	PRIMARY & SUPPLY
→→→	YELLOW	PARKING BRAKE
→→→	BLUE	SUSPENSION
→→→	BLACK	ACCESSORIES

BALLOON	PIPE
#1	3/8" O.D. BLUE
#2	1/4" O.D. BLACK
=====	STD PIPING
=====	OPTIONAL PIPING

NOTE:

CONTROL VALVE OPT. "LOW-BUOY" , "A" OR "B" SETTING:

POSITION "A": VALVE IS OPEN,
AIR FLOW BETWEEN SUPPLY (S) AND
DELIVERY (D) , LOW-BUOY IS NOT IN FUNCTION.

POSITION "B": VALVE CLOSED,
AIR DOESN'T FLOW BETWEEN SUPPLY (S) AND
DELIVERY (D) , LOW-BUOY IS IN FUNCTION.

XL2-45 COACH,
ENGINE 2002 WITH
FRONT BEAM AXLE

WITH OPTION FRONT KNEELING
& LOW-BUOY COMBINATION

DATE : 2004/02

D1 40301 P2 REV. B

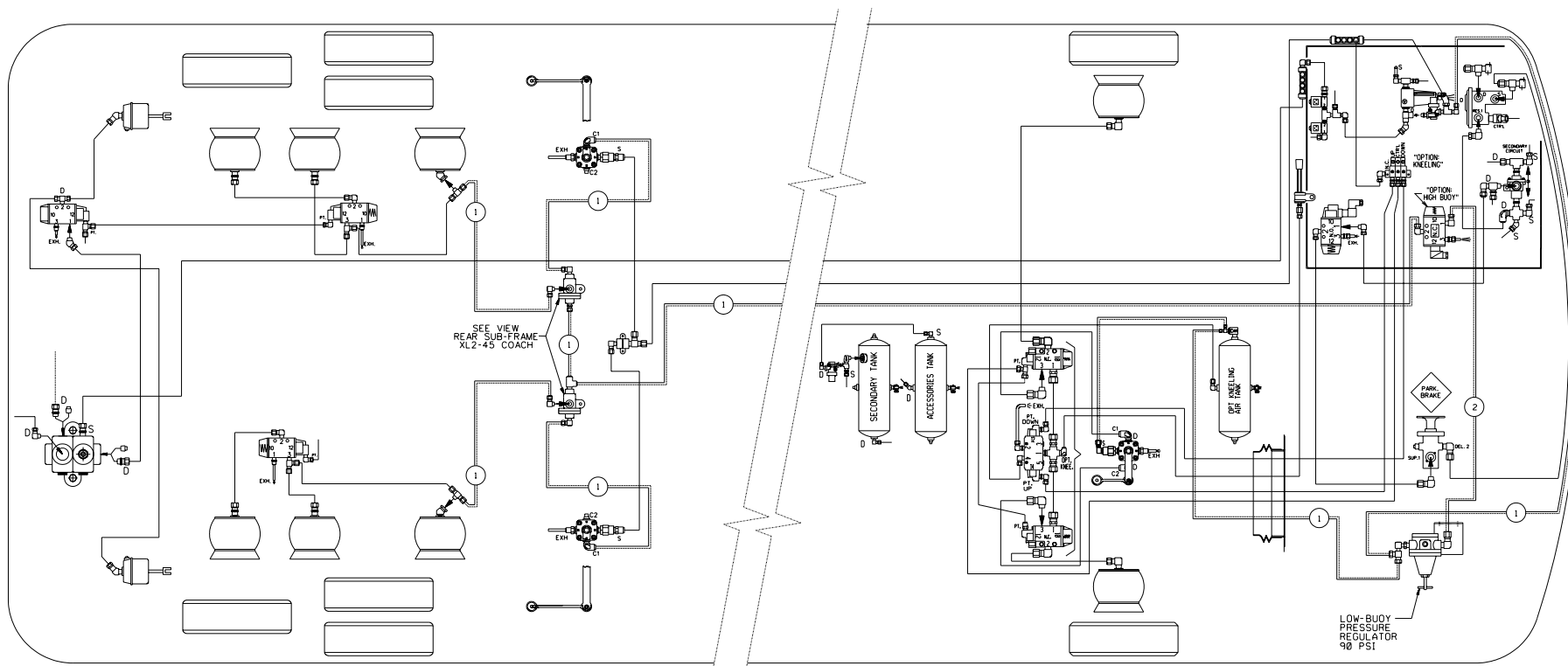

NOTE:

CONTROL VALVE OPT. "LOW-BUOY" , "A" OR "B" SETTING:

POSITION "A": VALVE IS OPEN,
AIR FLOW BETWEEN SUPPLY (S) AND
DELIVERY (D) , LOW-BUOY IS NOT IN FUNCTION.

POSITION "B": VALVE CLOSED,
AIR DOESN'T FLOW BETWEEN SUPPLY (S) AND
DELIVERY (D) , LOW-BUOY IS IN FUNCTION.

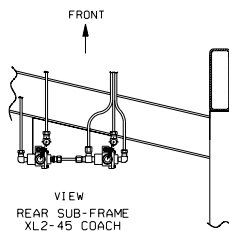

TUBE COLOR CODING	
ACTIVE COLOR	CIRCUIT
→ → RED	SECONDARY
→ → GREEN	PRIMARY & SUPPLY
→ → YELLOW	PARKING BRAKE
→ → BLUE	SUSPENSION
→ → BLACK	ACCESSORIES

BALLOON	PIPE
• 1	3/8" O.D. BLUE
• 2	1/2" O.D. BLUE
—	STD PIPING
—	OPTIONAL PIPING

XL2-45 COACH,
ENGINE 2002 WITH
FRONT BEAM AXLE

WITH OPTION FRONT KNEELING
& HIGH-BUOY COMBINATION

D140301 P3 REV. A

DATE : 2003/04

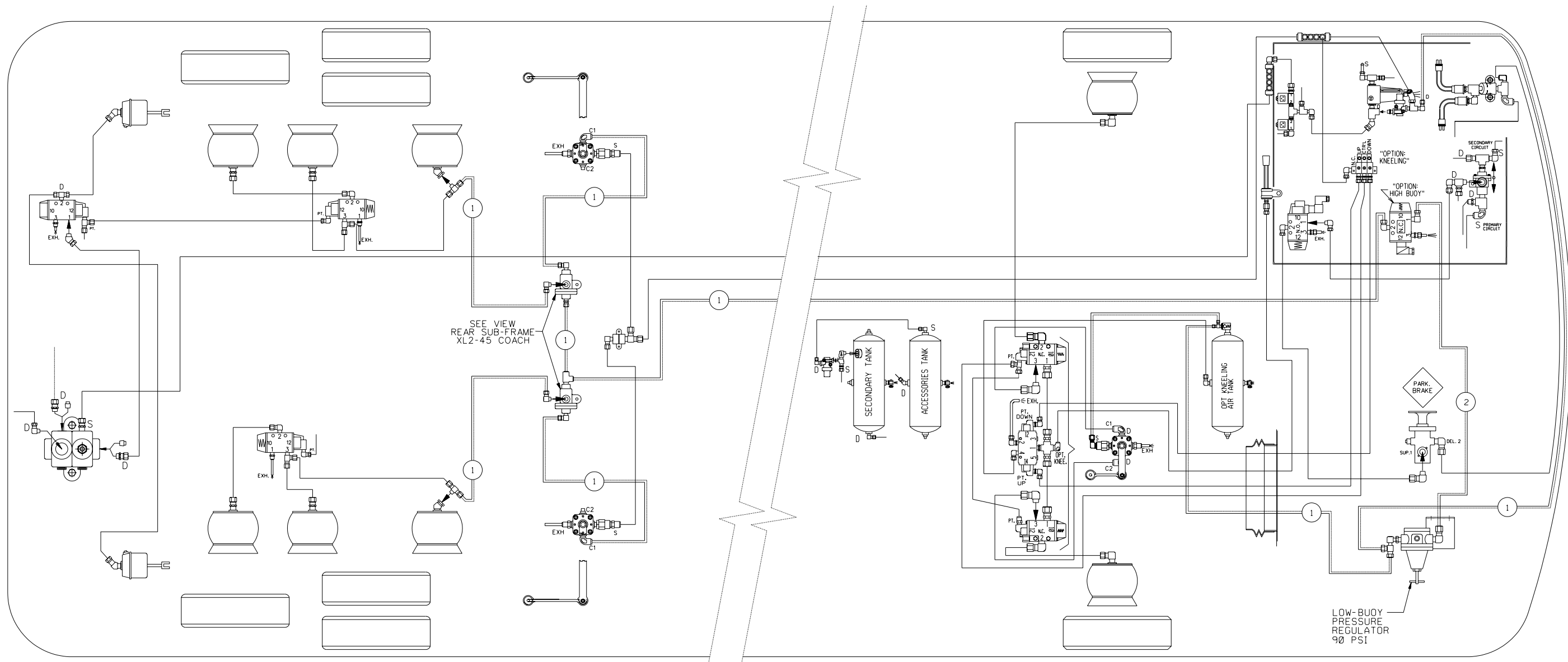

SEE VIEW
REAR SUB-FRAME
XL2-45 COACH

LOW-BUOY
PRESSURE
REGULATOR
90 PSI

NOTE:

CONTROL VALVE OPT. "LOW-BUOY" , "A" OR "B" SETTING:
POSITION "A": VALVE IS OPEN,
 AIR FLOW BETWEEN SUPPLY (S) AND
 DELIVERY (D) , LOW-BUOY IS NOT IN FUNCTION.

POSITION "B": VALVE CLOSED,
 AIR DOESN'T FLOW BETWEEN SUPPLY (S) AND
 DELIVERY (D) , LOW-BUOY IS IN FUNCTION.

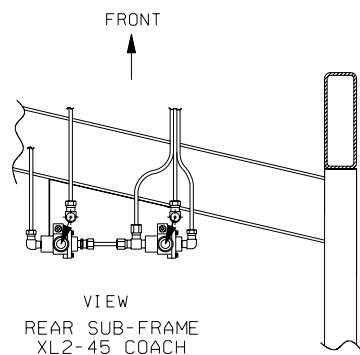

TUBE COLOR CODING		
ACTIVE	COLOR	CIRCUIT
->->	RED	SECONDARY
->->	GREEN	PRIMARY & SUPPLY
->->	YELLOW	PARKING BRAKE
->->	BLUE	SUSPENSION
->->	BLACK	ACCESSORIES

BALLOON	PIPE
#1	3/8" O.D. BLUE
#2	1/2" O.D. BLUE
=====	STD PIPING
=====	OPTIONAL PIPING

XL2-45 COACH,
 ENGINE 2002 WITH
 FRONT BEAM AXLE

 WITH OPTION FRONT KNEELING
 & HIGH-BUOY COMBINATION

 D1 40301 P3 REV. B

DATE : 2004/02

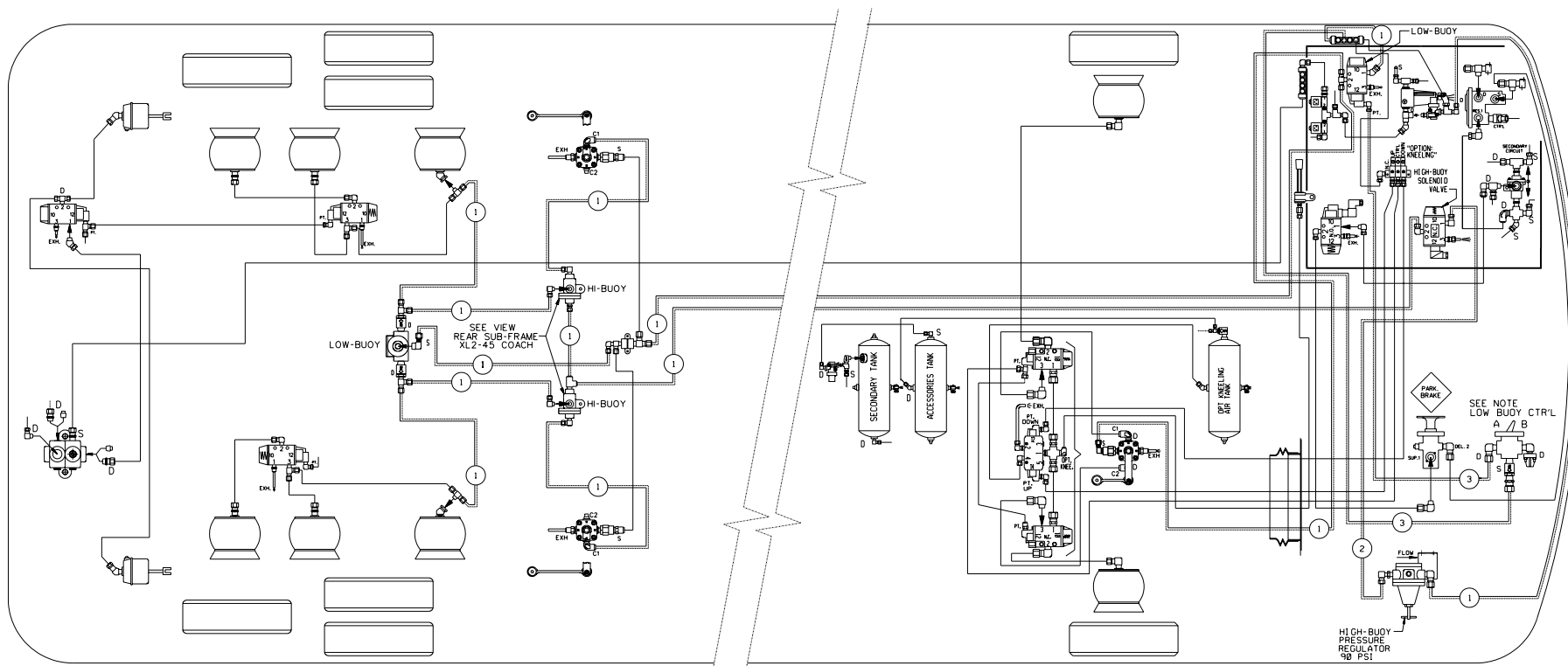

NOTE:

CONTROL VALVE OPT. "LOW-BUOY", "A" OR "B" SETTING:

POSITION "A": VALVE IS OPEN, AIR FLOW BETWEEN SUPPLY (S) AND DELIVERY (D), LOW-BUOY IS NOT IN FUNCTION.

POSITION "B": VALVE CLOSED, AIR DOESN'T FLOW BETWEEN SUPPLY (S) AND DELIVERY (D), LOW-BUOY IS IN FUNCTION.

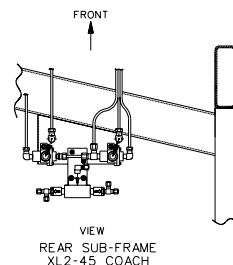

TUBE COLOR CODING	
ACTIVE COLOR	CIRCUIT
→ → RED	SECONDARY
→ → GREEN	PRIMARY & SUPPLY
→ → YELLOW	PARKING BRAKE
→ → BLUE	SUSPENSION
→ → BLACK	ACCESSORIES

BALLOON	PIPE
*1	3/8" O.D. BLUE
*2	1/2" O.D. BLUE
*3	1/4" O.D. BLACK
—	STD PIPING
—	OPTIONAL PIPING

XL2-45 COACH,
ENGINE 2002 WITH
FRONT BEAM AXLE

WITH OPTION FRONT
KNEELING, LOW-BUOY
& HIGH-BUOY COMBINATION
D140301 P4 REV.A

DATE : 2003/04

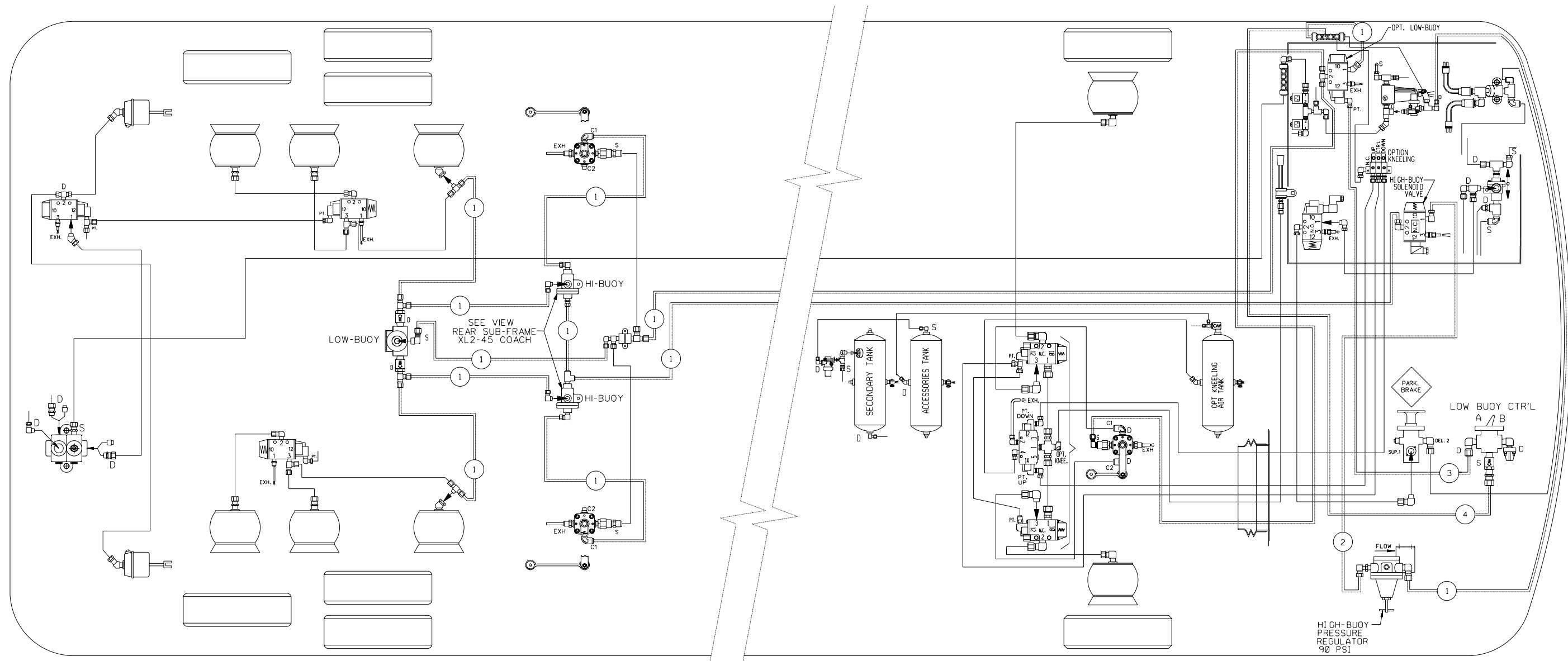

NOTE:

CONTROL VALVE OPT. "LOW-BUOY" , "A" OR "B" SETTING:

POSITION "A": VALVE IS OPEN,
AIR FLOW BETWEEN SUPPLY (S) AND
DELIVERY (D) , LOW-BUOY IS NOT IN FUNCTION.

POSITION "B": VALVE CLOSED,
AIR DOESN'T FLOW BETWEEN SUPPLY (S) AND
DELIVERY (D) , LOW-BUOY IS IN FUNCTION.

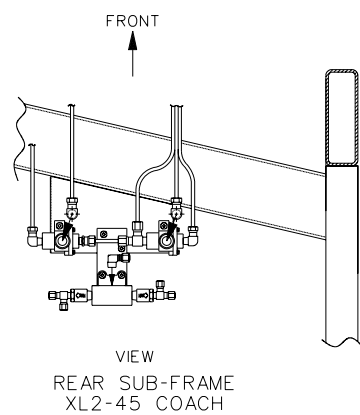

TUBE COLOR CODING		
ACTIVE	COLOR	CIRCUIT
→→→	RED	SECONDARY
→→→	GREEN	PRIMARY & SUPPLY
→→→	YELLOW	PARKING BRAKE
→→→	BLUE	SUSPENSION
→→→	BLACK	ACCESSORIES

BALLOON	PIPE
#1	3/8" O.D. BLUE
#2	1/2" O.D. BLUE
#3	1/4" O.D. BLACK
—	STD PIPING
—	OPTIONAL PIPING

XL2-45 COACH,
ENGINE 2002 WITH
FRONT BEAM AXLE

WITH OPTION FRONT
KNEELING, LOW-BUOY
& HIGH-BUOY COMBINATION

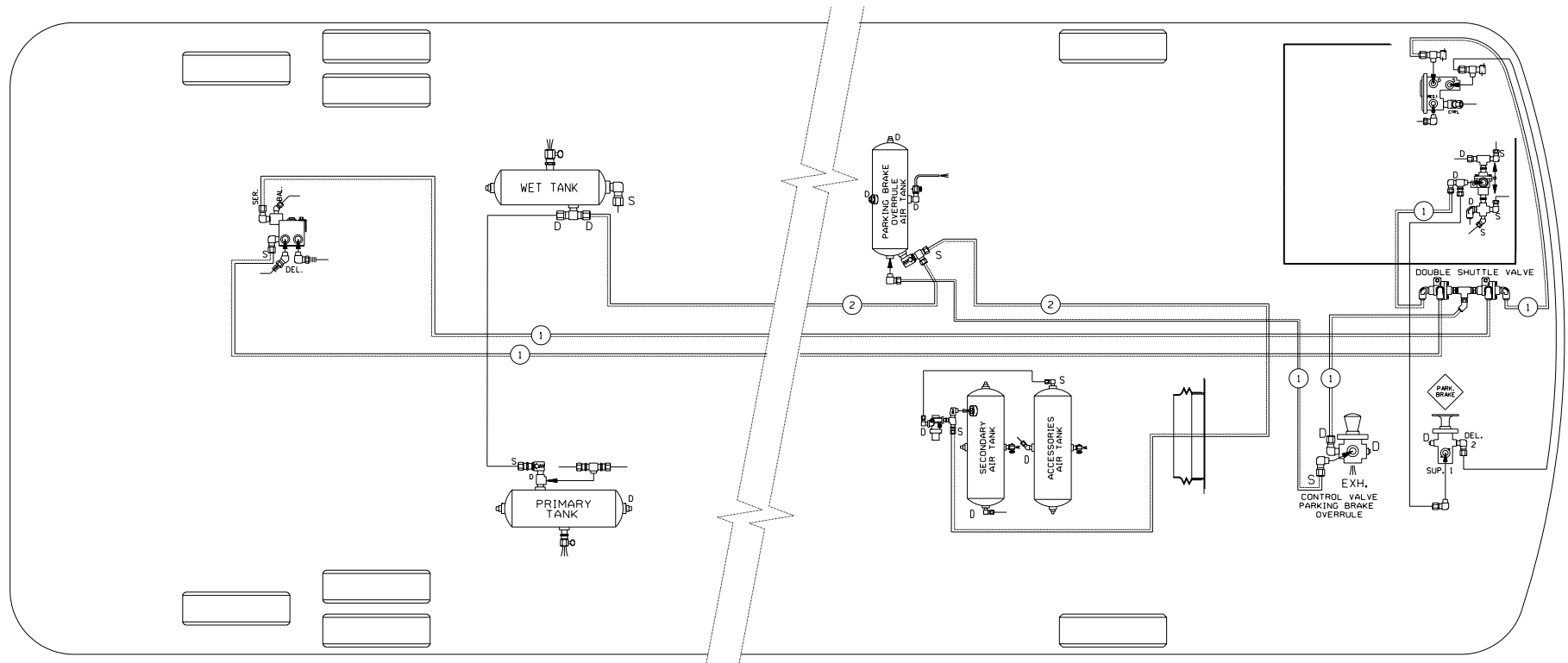

TUBE COLOR CODING		
ACTIVE	COLOR	CIRCUIT
→ →	RED	SECONDARY
→ →	GREEN	PRIMARY & SUPPLY
→ →	YELLOW	PARKING BRAKE
→ →	BLUE	SUSPENSION
→ →	BLACK	ACCESSORIES

BALLOON	PIPE
*1	3/8" O.D. YELLOW
*2	5/8" O.D. GREEN
—	STD PIPING
----	OPTIONAL PIPING

DATE : 2003/06

XL2-45 COACH,
 ENGINE 2002 WITH
 FRONT BEAM AXLE
 WITH OPTION PARKING
 BRAKE OVERRULE
 D140301 P5 REV. A

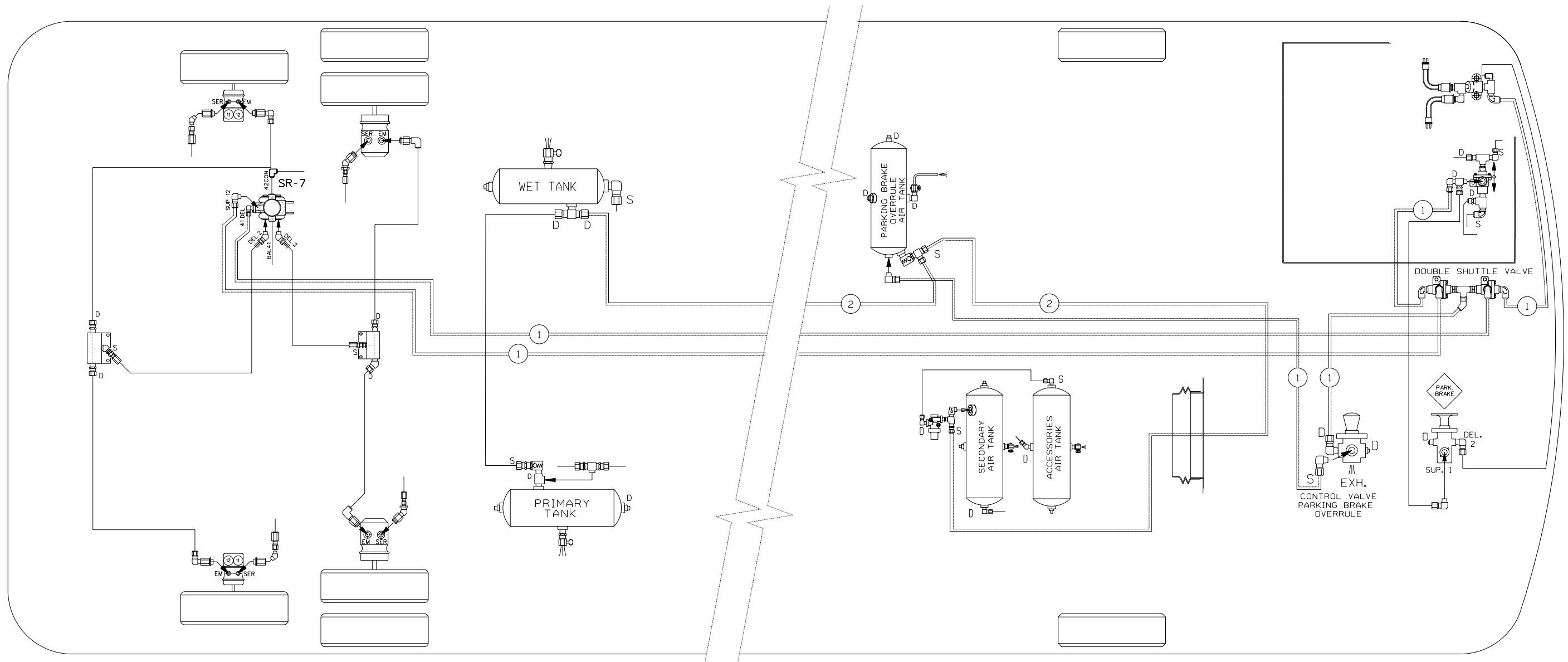

TUBE COLOR CODING	
ACTIVE COLOR	CIRCUIT
→ → → RED	SECONDARY
→ → → GREEN	PRIMARY & SUPPLY
→ → → YELLOW	PARKING BRAKE
→ → → BLUE	SUSPENSION
→ → → BLACK	ACCESSORIES

BALLOON	PIPE
#1	3/8" O.D. YELLOW
#2	5/8" O.D. GREEN
#3	1/2" O.D. YELLOW
—	STD PIPING
—	OPTIONAL PIPING

XL2-45 COACH,
 ENGINE 2002 WITH
 FRONT BEAM AXLE
 WITH OPTION PARKING
 BRAKE OVERRULE
 D1 40301 P5 REV. B

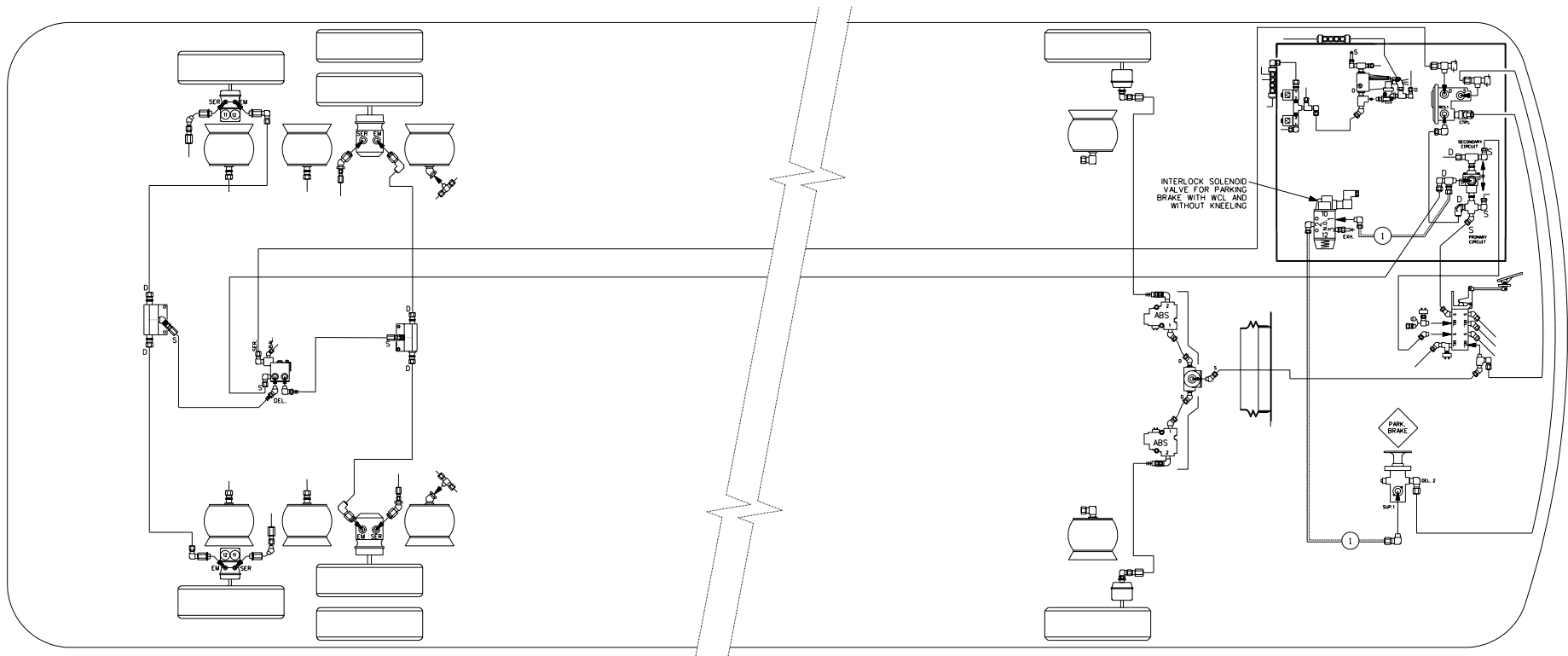

TUBE COLOR CODING	
ACTIVE COLOR	CIRCUIT
→ → RED	SECONDARY
→ → GREEN	PRIMARY & SUPPLY
→ → YELLOW	PARKING BRAKE
→ → BLUE	SUSPENSION
→ → BLACK	ACCESSORIES

BALLOON	PIPE
*1	3/8" O.D. YELLOW
————	STD PIPING
————	OPTIONAL PIPING

XL2-45 COACH,
 ENGINE 2002
 WITH FRONT BEAM AXLE
 WITH OPTION PARKING BRAKE
 WITH WHEELCHAIR LIFT
 AND WITHOUT KNEELING
 D140301 P6 REV. A

DATE : 2003/04



TUBE COLOR CODING		
ACTIVE	COLOR	CIRCUIT
→ → →	RED	SECONDARY
→ → →	GREEN	PRIMARY & SUPPLY
→ → →	YELLOW	PARKING BRAKE
→ → →	BLUE	SUSPENSION
→ → →	BLACK	ACCESSORIES

BALLOON	PIPE
#1	3/8" O.D. YELLOW
———	STD PIPING
=====	OPTIONAL PIPING

XL2-45 COACH,
 ENGINE 2002
 WITH FRONT BEAM AXLE
 WITH OPTION PARKING BRAKE
 WITH WEELCHAIR LIFT
 AND WITHOUT KNEELING
 D1 40301 P6 REV. B

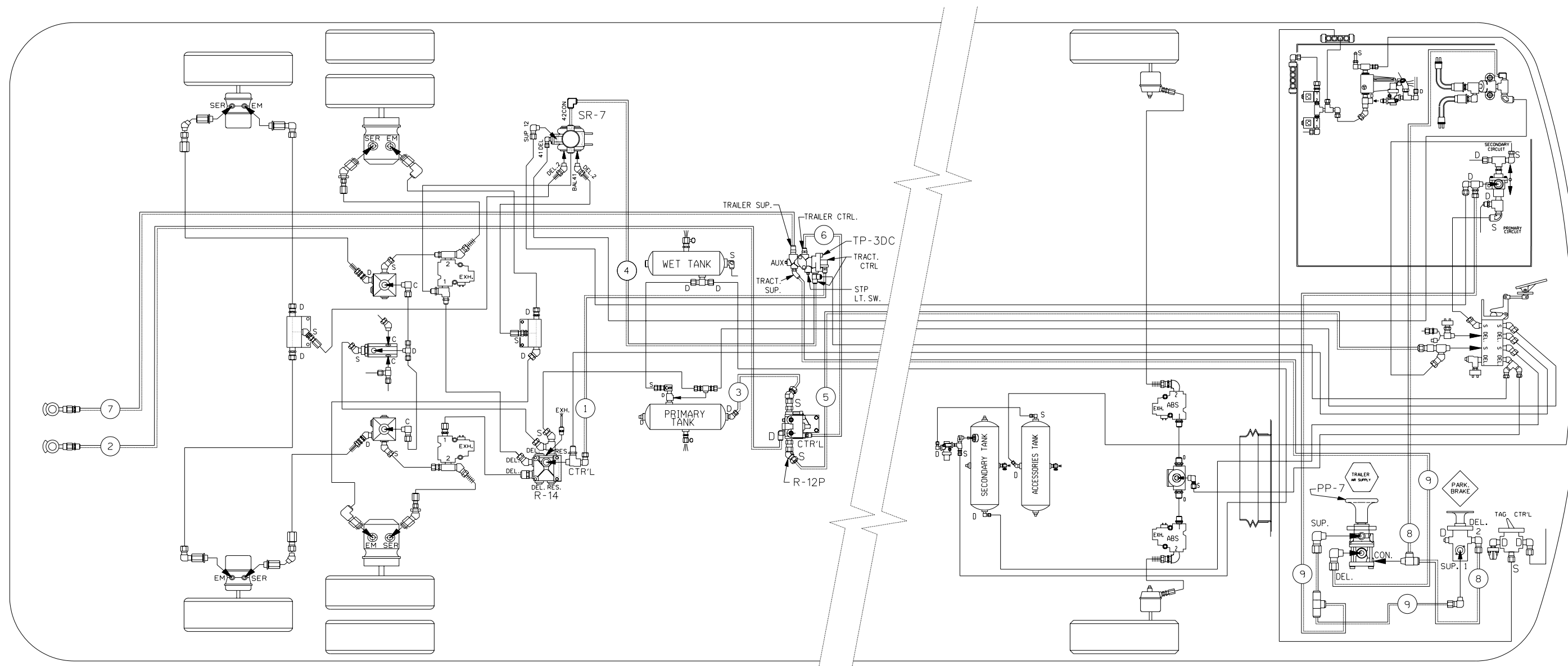

TUBE COLOR CODING		
ACTIVE	COLOR	CIRCUIT
→ → →	RED	SECONDARY
→ → →	GREEN	PRIMARY & SUPPLY
→ → →	YELLOW	PARKING BRAKE
→ → →	BLUE	SUSPENSION
→ → →	BLACK	ACCESSORIES

BALLOON	PIPE
#1	3/8" O.D. GREEN
#2	1/2" O.D. GREEN
#3	5/8" O.D. GREEN
#4	3/8" O.D. RED
#5	5/8" O.D. RED
#6	3/8" O.D. BROWN
#7	1/2" O.D. BROWN
#8	1/4" O.D. YELLOW
#9	3/8" O.D. YELLOW
=====	STD PIPING
=====	OPTIONAL PIPING

XL2-45 COACH,
ENGINE 2002
WITH FRONT BEAM AXLE

WITH OPTION
TRAILER HITCH

D1 40301 P9 REV. A

TUBE COLOR CODING	
ACTIVE COLOR	CIRCUIT
→ → RED	SECONDARY
→ → GREEN	PRIMARY & SUPPLY
→ → YELLOW	PARKING BRAKE
→ → BLUE	SUSPENSION
→ → BLACK	ACCESSORIES

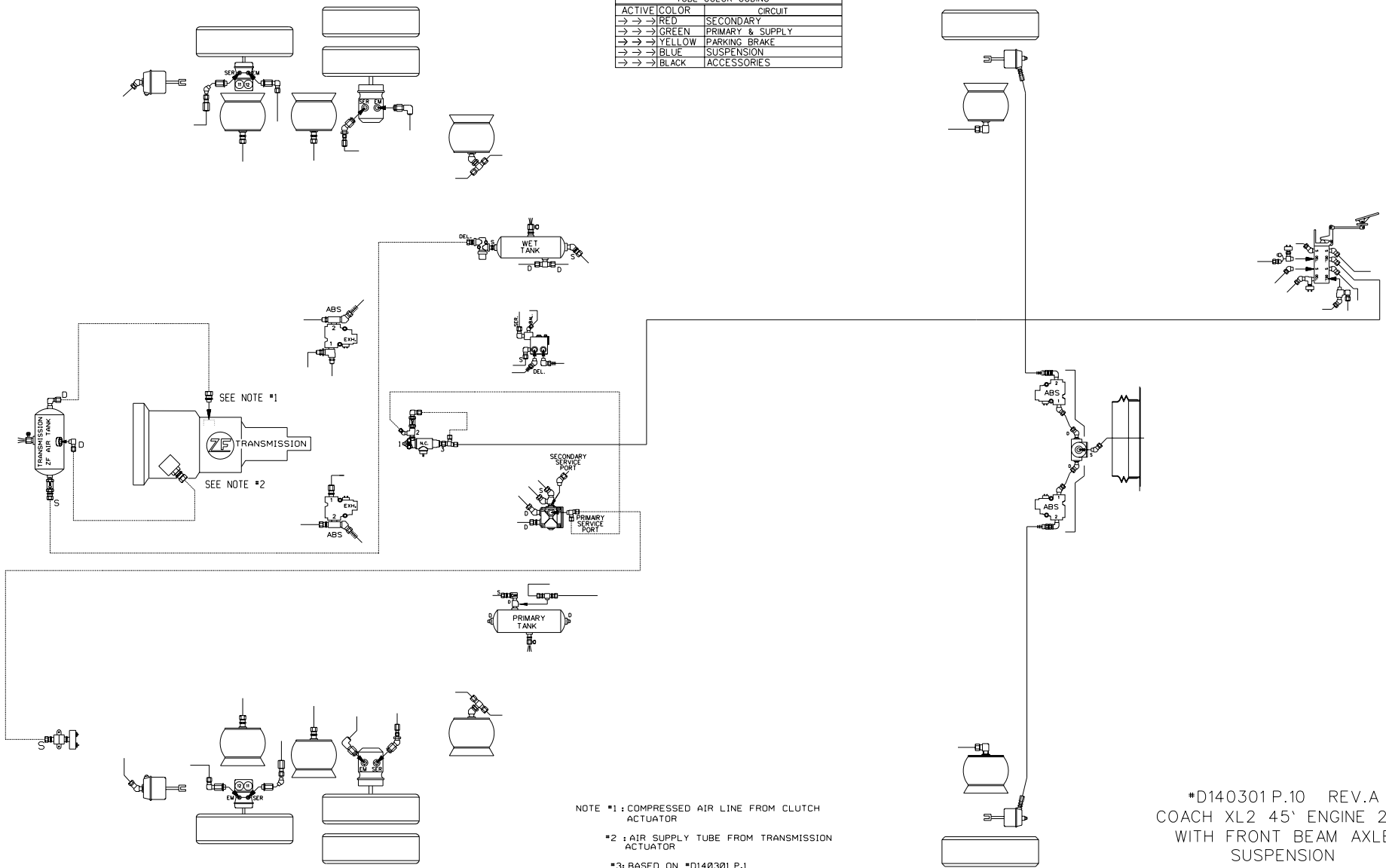

DATE: 2002-11

#D140301 P.10 REV.A
 COACH XL2 45' ENGINE 2002
 WITH FRONT BEAM AXLE
 SUSPENSION
 OPTION TRANSMISSION ZF

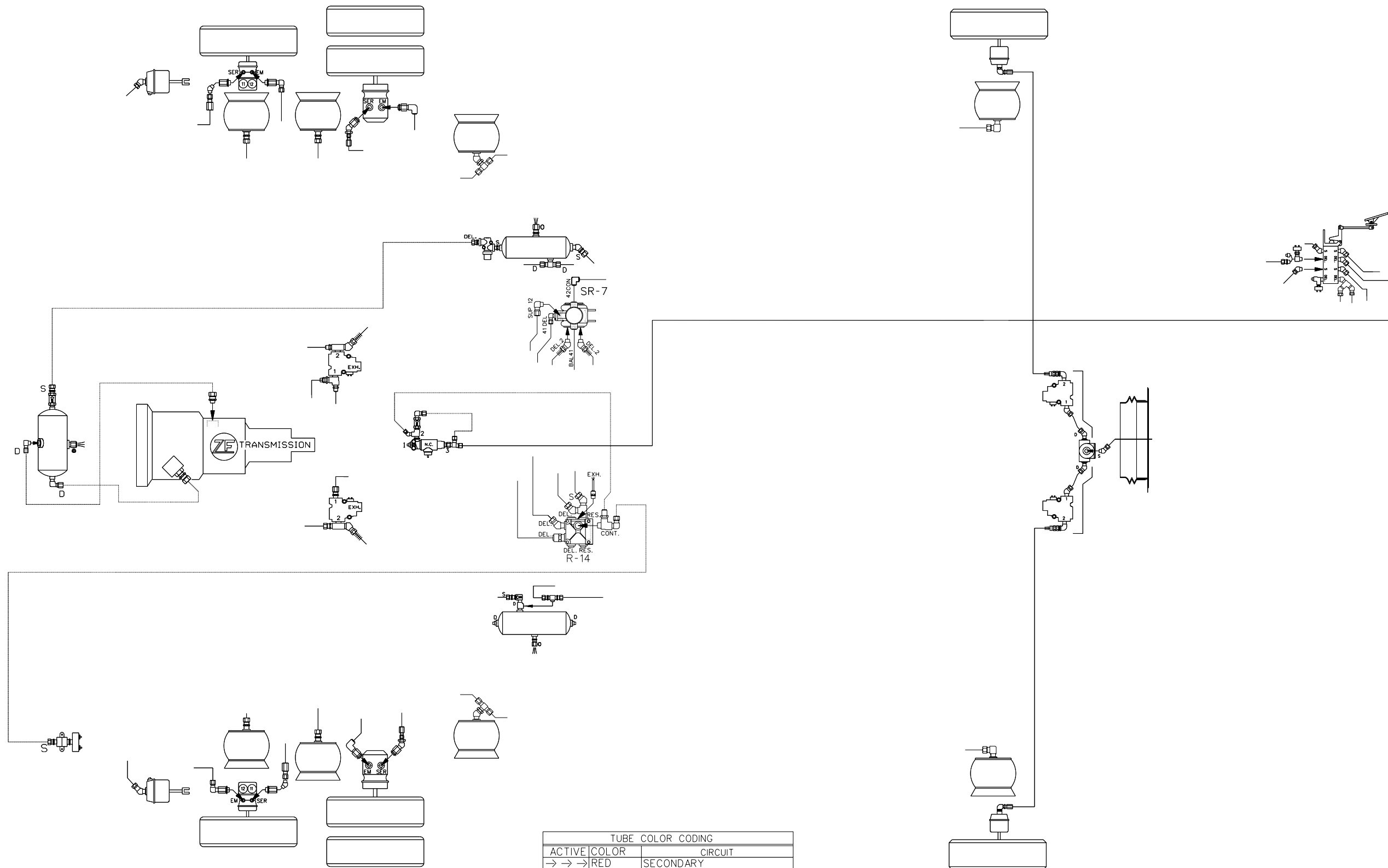

NOTE #1: COMPRESSED AIR LINE FOR CLUTCH ACTUATOR
 #2: COMPRESSED AIR LINE FOR TRANSMISSION ACTUATOR
 #3: BASED ON #D140300 P.1

XL2-45 COACH,
 ENGINE 2002
 WITH FRONT BEAM AXLE

WITH OPTION
 TRANSMISSION ZF
 D140301 P10 REV. C

DATE : 2004/02



TUBE COLOR CODING		
ACTIVE	COLOR	CIRCUIT
→ → →	RED	SECONDARY
→ → →	GREEN	PRIMARY & SUPPLY
→ → →	YELLOW	PARKING BRAKE
→ → →	BLUE	SUSPENSION
→ → →	BLACK	ACCESSORIES

BALLOON	PIPE
#1	1/4" O.D. YELLOW
#2	3/8" O.D. YELLOW
———	STD PIPING
=====	OPTIONAL PIPING

XL2-45 COACH, ORLEANS
 ENGINE 2002
 WITH FRONT BEAM AXLE
 WITH OPTION PARKING BRAKE
 RELEASE WITH
 SUPPLEMENTARY SWITCH
 D1 40301 P.11 REV. A



TUBE COLOR CODING		
ACTIVE	COLOR	CIRCUIT
→ → →	RED	SECONDARY
→ → →	GREEN	PRIMARY & SUPPLY
→ → →	YELLOW	PARKING BRAKE
→ → →	BLUE	SUSPENSION
→ → →	BLACK	ACCESSORIES

BALLOON	PIPE
#1	1/4" O.D. YELLOW
#2	3/8" O.D. YELLOW
———	STD PIPING
=====	OPTIONAL PIPING

XL2-45 COACH, ORLEANS
 ENGINE 2002
 WITH FRONT BEAM AXLE
 WITH OPTION PARKING BRAKE
 RELEASE WITH
 SUPPLEMENTARY SWITCH
 D1 40301 P.11 REV. B