

**Prévost Car**

**PA 1081**

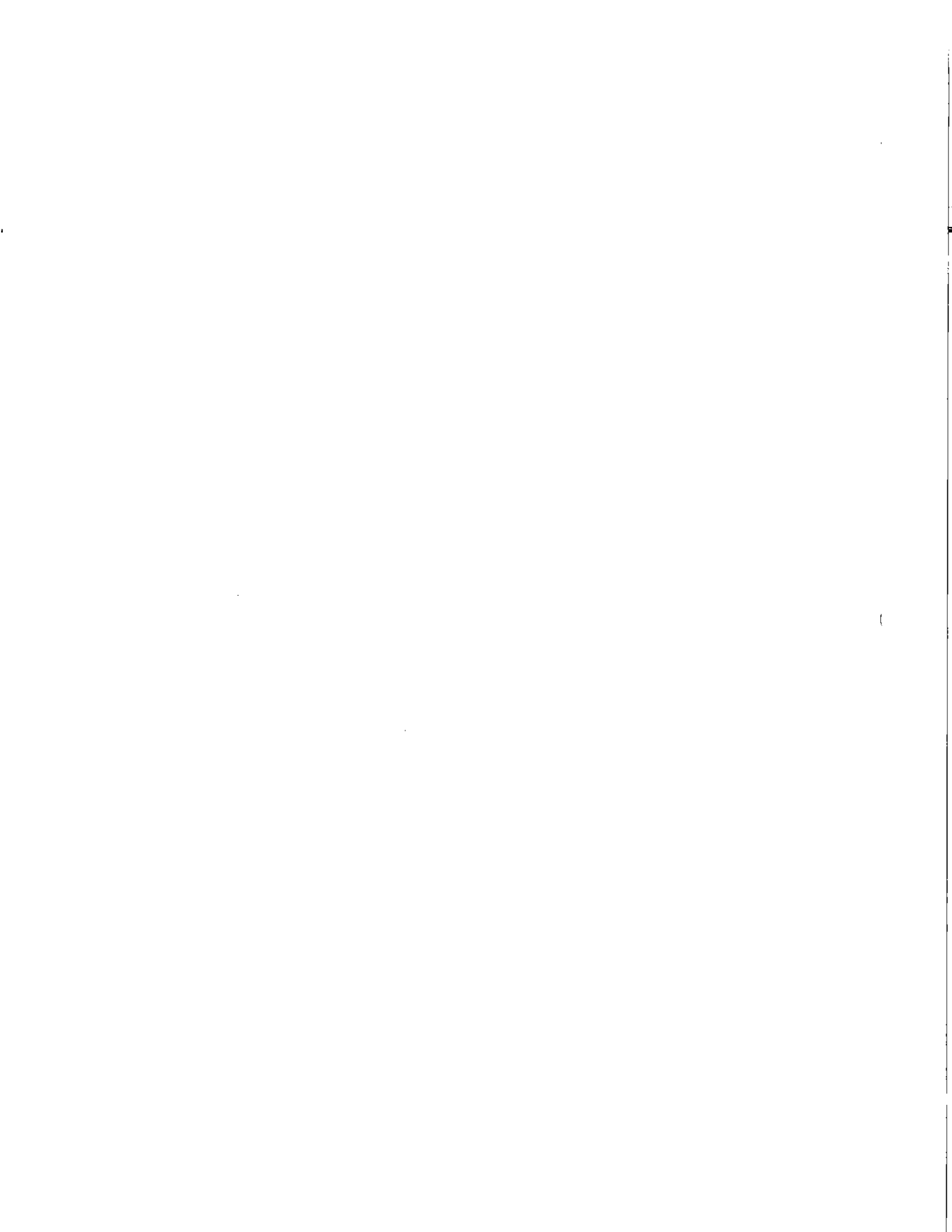

# **MAINTENANCE MANUAL**

## **H3-41 & 45**

**PA-1081**

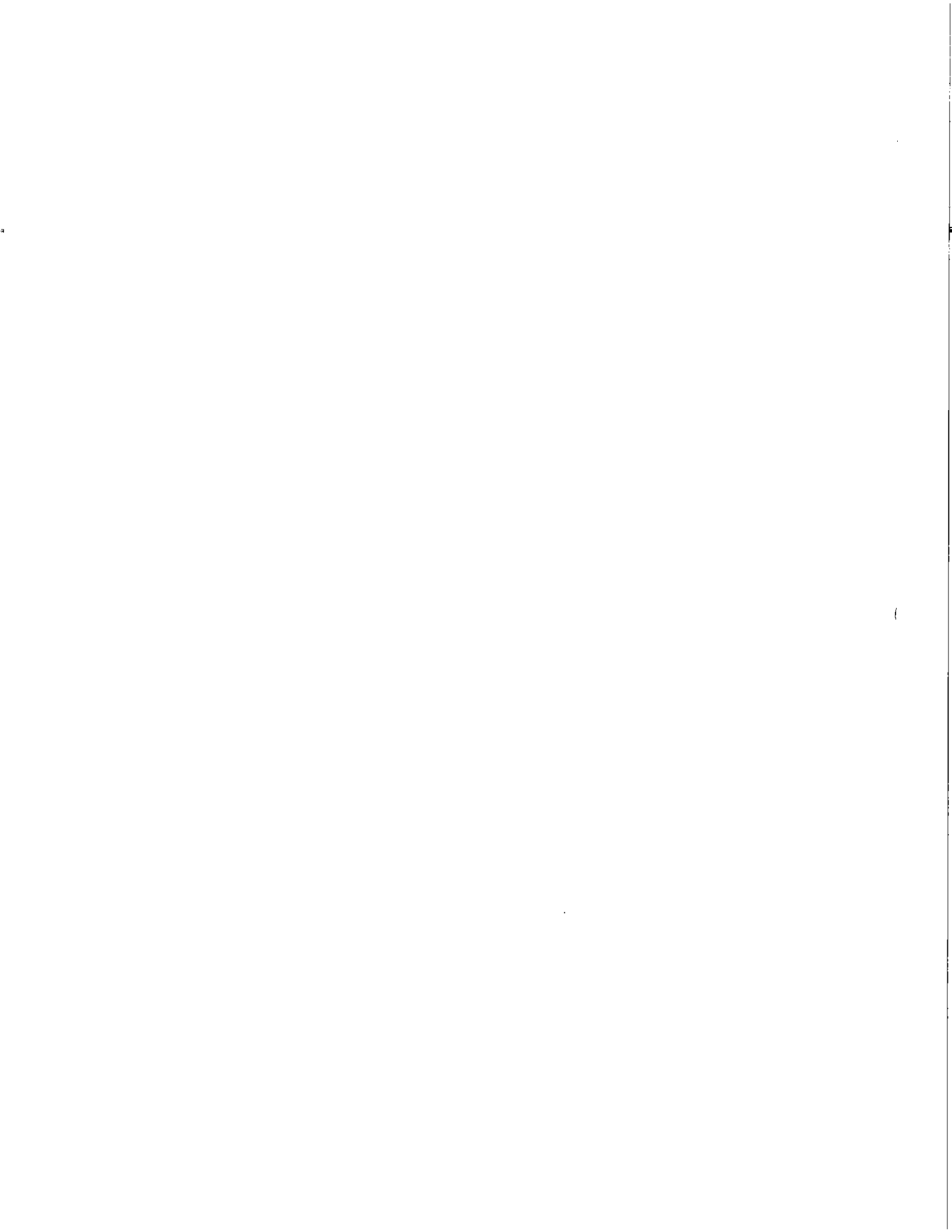



# SECTION 01: ENGINE

---

## CONTENTS

1. ENGINE.....	2
1.1 Description.....	2
2. ENGINE-MOUNTED COMPONENTS .....	2
2.1 Electronic Control Module .....	3
2.2 Electronic Unit Injector.....	3
2.3 Synchronous Reference Sensor .....	4
2.4 Timing Reference Sensor.....	5
2.5 Turbo Boost Pressure Sensor.....	5
2.6 Coolant Temperature Sensor .....	5
2.7 Fuel Temperature Sensor .....	5
2.8 Air Temperature Sensor.....	6
2.9 Oil Pressure Sensor .....	6
2.10 Oil Temperature Sensor.....	6
3. ENGINE-RELATED COMPONENTS.....	6
3.1 Coolant Level System (CLS).....	7
3.2 Electronic Foot Pedal Assembly (EFPA) & Throttle Position Sensor .....	7
3.3 Cruise Control Switch .....	7
3.4 Diagnostic System Accessories.....	8
4. DDEC III Diagnostic Codes.....	9
4.1 Reading Diagnostic Codes - Flash Method .....	9
4.2 DDEC III Diagnostic Codes List .....	10
5. ENGINE OIL LEVEL .....	13
6. ENGINE OIL AND FILTER CHANGE .....	13
7. RECOMMENDED ENGINE OIL TYPE .....	14
8. WELDING PRECAUTION .....	14
9. POWER PLANT ASSEMBLY REMOVAL (Automatic and Manual) .....	15
10. POWER PLANT ASSEMBLY INSTALLATION (Automatic and Manual) .....	18
11. ENGINE MOUNTS.....	19
12. JAKE BRAKE .....	19
13. SPECIFICATIONS .....	20

# 1. ENGINE

## 1.1 Description

This vehicle is powered by a 6-cylinder, four-cycle, Detroit Diesel series 60 engine, equipped with an electronic control system (DDEC III). Two volumes of charge are used in the engine: 11 liters or 12.7 liters. Summary information on the Electronic Control System is given in this section. Complete maintenance and repair information on the engine will be found in the current DDEC III Service Manual #6SE483. Engine controls, accessories and related components are covered in the applicable sections of this maintenance manual. Engine removal and installation procedures are given at the end of this section. The DDEC system is self-diagnostic. It can identify faulty components and other engine-related problems by providing the technician with a diagnostic code. Refer to DDEC Troubleshooting Guide # 6SE492 for more complete information on diagnosis of components and system problems published by Detroit Diesel.

DDEC III (Detroit Diesel Electronic Control) controls the timing and amount of fuel injection by the electronic unit injectors (EUI). The system also monitors several engine functions using electrical sensors which send electrical signals to the Electronic Control Module (ECM). The ECM computes the electrical signals and determines the correct fuel output and timing for optimum power, fuel economy and emissions. The ECM also has the ability to display warnings or shut down the engine completely (depending on option selection) in the event of damaging engine conditions, such as low oil pressure, low coolant, or high oil temperature.

The system components are divided in two categories: engine-mounted components and engine-related components.

## 2. ENGINE-MOUNTED COMPONENTS

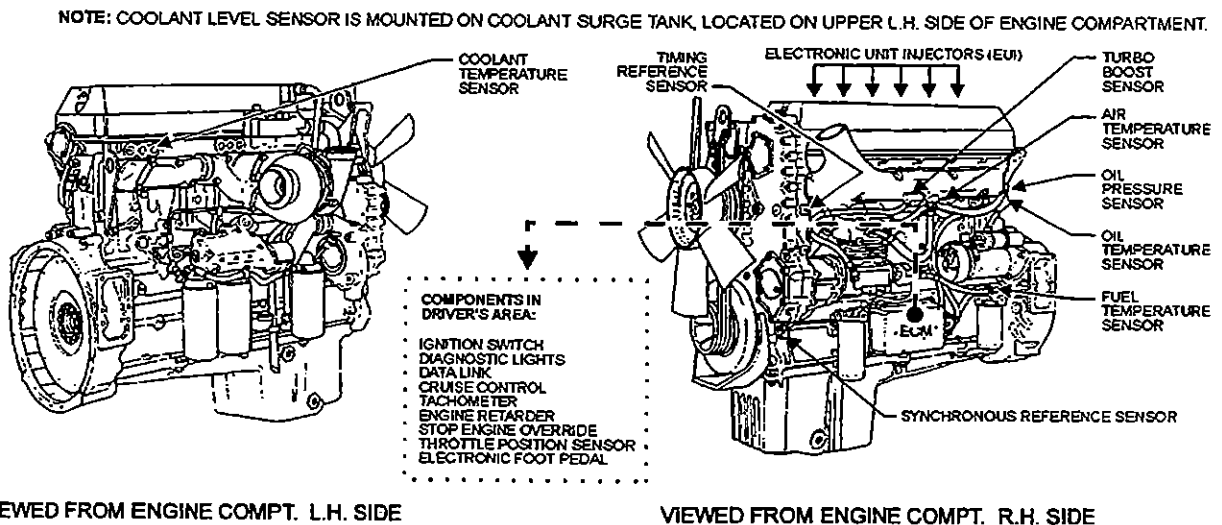

Figure 1: Detroit Diesel Series 60 Engine

01015

Engine-mounted components are as follows:

- Electronic Control Module
- Electronic Unit Injector
- Synchronous Reference Sensor
- Timing Reference Sensor
- Turbo Boost Pressure Sensor
- Coolant Temperature Sensor
- Fuel Temperature Sensor
- Air Temperature Sensor
- Oil Pressure Sensor
- Oil Temperature Sensor

## 2.1 Electronic Control Module

The Electronic Control Module is mounted, on the starter side of the engine (see fig. 2). It is considered the "Brain" of the DDEC III system because it provides overall monitoring and control of the engine by comparing input data from the various sensors to a set of calibration data stored in the EEPROM (Electrically Erasable, Programmable, Read-Only Memory) within the Electronic Control Module. After comparing the input data with the calibrations data, the ECM sends high current command pulses to the Electronic Unit Injectors (EUI) to initiate fuel injection. The ECM also receives feedback regarding the start and end of injection for a given cylinder.

The EEPROM within the Electronic Control Module is factory programmed by Detroit Diesel. Reprogramming must be done at a Detroit Diesel authorized service center. However, some changes may be performed to the cruise control and road speed limit using a diagnostic data reader (see 4. DDEC III Diagnostic Codes in this section).

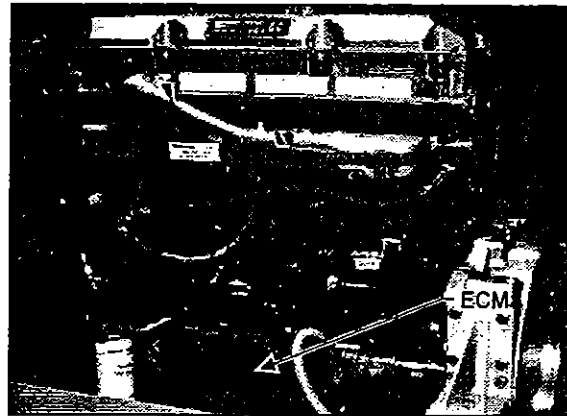

Figure 2: Electronic Control Module (ECM) 01018

## 2.2 Electronic Unit Injector

The Electronic Unit Injector is a compact unit that injects diesel fuel directly into the combustion chamber (Fig. 3). The amount of fuel injected and beginning of injection timing is determined by the Electronic Control Module (ECM). The ECM sends a command pulse which activates the injector solenoid. The EUI performs four functions:

- Creates the high-fuel pressure required for efficient injection
- Meters and injects the exact amount of fuel required to handle the load
- Atomizes the fuel for mixing with the air in the combustion chamber
- Permits continuous fuel flow for component cooling

## Section 01: Engine

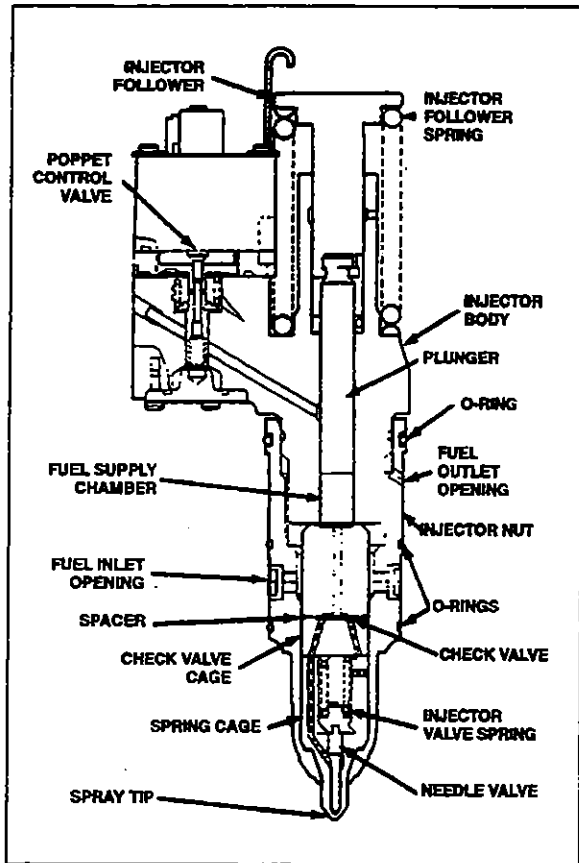

01019

Figure 3: Electronic Unit Injector Cross-Section

### 2.3 Synchronous Reference Sensor

The Synchronous Reference Sensor (SRS) is an electronic component that is mounted to the rear of the gear case (Fig. 4). The SRS sensor extends through a hole in the gear case and is positioned near the rear of the bull gear. A bolt, inserted through a hole in the SRS bracket, secures the SRS assembly to the gear case. The SRS connector is black. The SRS sends a signal to the ECM. This signal is generated by a raised metal pin on the rear of the bull gear (Fig. 5).

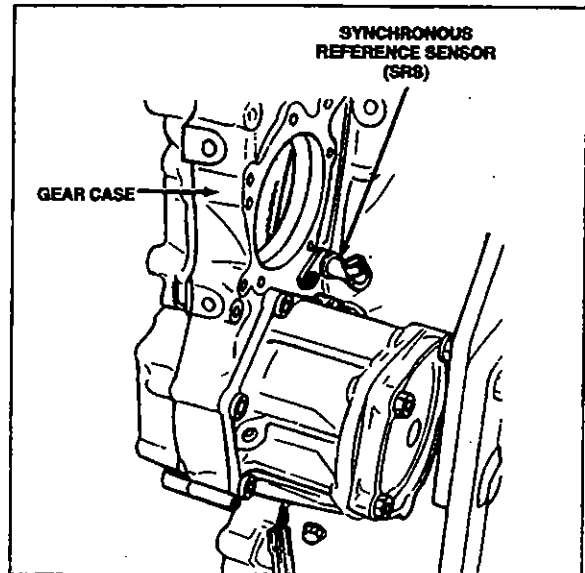

Figure 4: SRS Location

01020

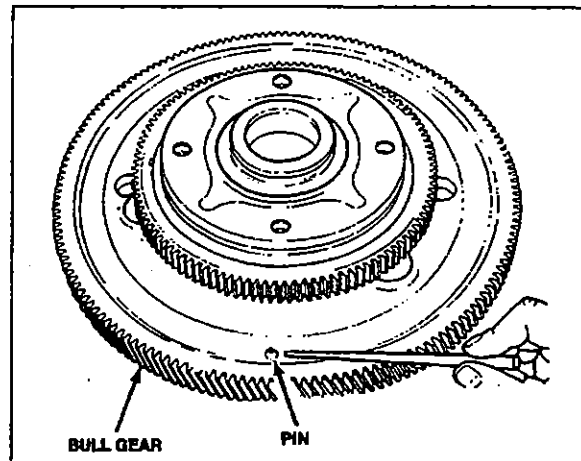

Figure 5: Bull Gear

01021

The bull gear pin passes by the SRS as the number one piston reaches 45° before Top-Dead-Center. This information is used by the ECM to determine engine speed.

The SRS is non-serviceable and must be replaced as a unit. No adjustment is required.

## 2.4 Timing Reference Sensor

The Timing Reference Sensor (TRS) is an electronic component that is mounted on the left side of the gear case, near the crankshaft center line (Fig. 6).

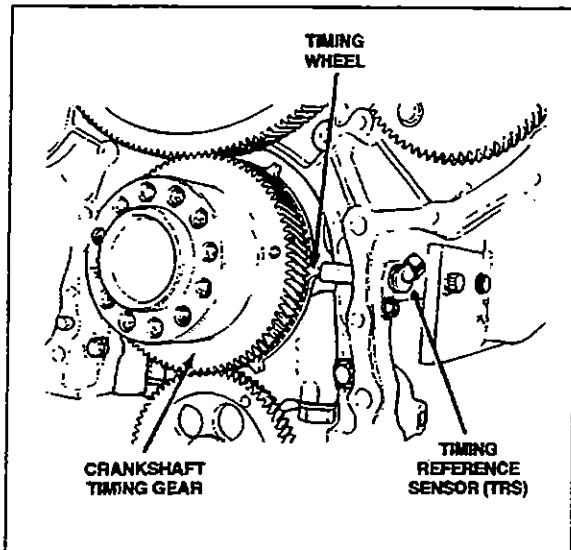

01022

Figure 6: Timing Reference Sensor and Related Parts

The TRS sensor extends through an opening in the gear case and is positioned near the timing wheel gear teeth. A bolt, inserted through a hole in the TRS bracket, secures the TRS assembly to the gear case. The TRS connector is gray.

The TRS sensor sends a signal to the ECM. This is generated by a series of evenly spaced teeth on the timing wheel, rotating by the crankshaft. A tooth passes by the TRS as each cylinder reaches 10° before Top-Dead-Center. These signals are used by the ECM to determine injector solenoid operation time. The TRS is non-serviceable and must be replaced as a unit. No adjustment is required.

## 2.5 Turbo Boost Pressure Sensor

The Turbo Boost Pressure Sensor is mounted to the intake manifold with two bolts. A rubber O-ring is used to seal the sensor to the manifold (Fig. 7). This device is a pressure sensor that sends an electrical signal to the ECM. The ECM uses this information to compute the amount of air entering the engine. Fuel supply is regulated by the turbo boost sensor information to control engine exhaust. The turbo boost sensor is non-serviceable and must be replaced as an assembly. No adjustment is required.

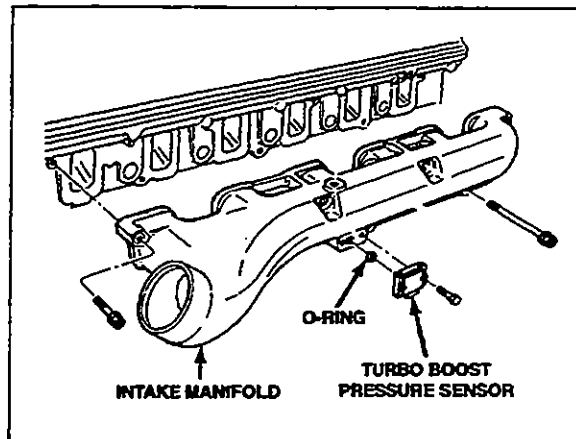

01023

Figure 7: Turbo Boost Pressure Sensor

## 2.6 Coolant Temperature Sensor

The coolant temperature sensor is mounted on the engine, on the radiator side of the engine (Fig. 1). The sensor protects the engine in case of overheating by sensing coolant temperature.

## 2.7 Fuel Temperature Sensor

The fuel Temperature Sensor (FTS) is installed on the secondary fuel filter (Fig. 8). The FTS sends an electrical signal to the ECM indicating fuel inlet temperature. The ECM uses this information to calculate fuel consumption.

## Section 01: Engine

The FTS is non-serviceable and must be replaced as a unit. No adjustment is required.

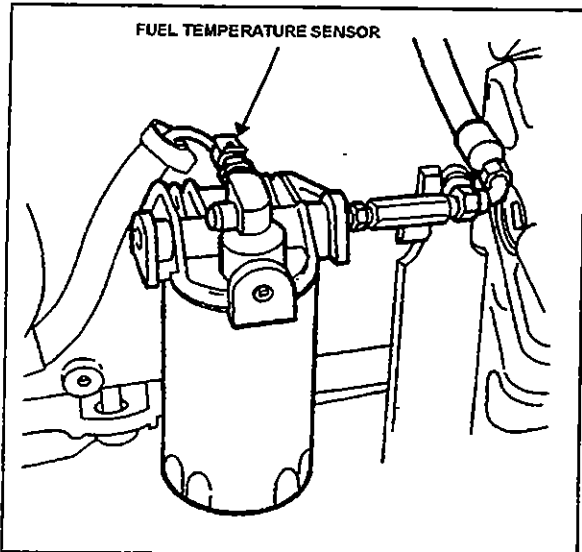

Figure 8: Engine Fuel Temperature Sensor 01024

### 2.8 Air Temperature Sensor

The Air Temperature Sensor (Fig. 1) located on the engine (starter side) near the intake manifold provides input data to vary hot idle speed and injection timing. This helps to improve cold starts and reduces white exhaust.

### 2.9 Oil Pressure Sensor

The Oil Pressure Sensor (OPS) is installed in the main engine oil gallery. A typical location is the left rear corner of the cylinder block (Fig. 9).

The OPS sends an electrical signal to the ECM indicating the engine oil pressure at any given speed. A low oil pressure signal exceeding seven seconds is used by the ECM to begin the stop engine or warning function. The OPS is non-serviceable and must be replaced as a unit. No adjustment is required.

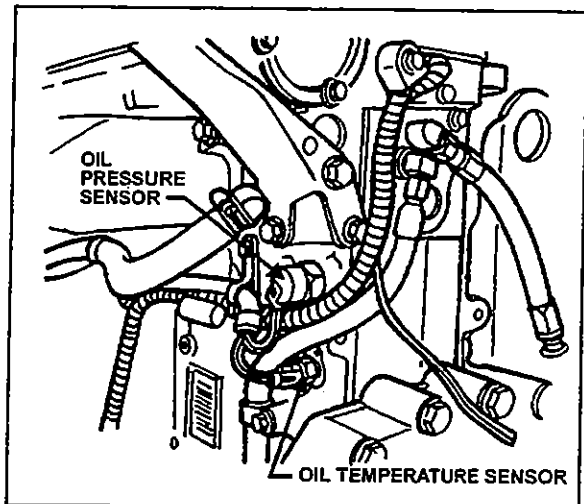

01025

Figure 9: Engine Oil Pressure and Oil Temperature Sensor

### 2.10 Oil Temperature Sensor

The Oil Temperature Sensor (OTS) is installed on the main engine oil gallery. A typical location is the left rear corner of the cylinder block as shown in Figure 9. The OTS sends an electrical signal to the ECM indicating engine oil temperature. The ECM uses this information to modify engine speed for better cold weather starts and faster warm-ups. Oil temperatures exceeding engine specifications for two seconds or more will illuminate the Check Engine Light. The OTS is non-serviceable and must be replaced as a unit. No adjustment is required.

## 3. ENGINE-RELATED COMPONENTS

Engine-related components:

- Coolant Level System (CLS)
- Electronic Foot Pedal Assembly (EFPA) and Throttle Position Sensor
- Cruise Control Switch (CCS)
- Diagnostic System Accessories (DSA)

### 3.1 Coolant Level System (CLS)

The coolant level system consists of a conductivity probe mounted in the surge tank and an electronic interface module located, inside the rear junction box. Coolant level is determined by the change in impedance of the probe and its brass mount when it is immersed in coolant. The electronic device in the module conditions the signal to levels compatible with DDEC. Low coolant level will trigger the warning engine functions. The probe and the electronic interface module are non-serviceable items and if found defective, they should be replaced as units. No adjustment is required.

### 3.2 Electronic Foot Pedal Assembly (EFPA) & Throttle Position Sensor

The Electronic Foot Pedal Assembly (EFPA) connects the accelerator pedal to a Throttle Position Sensor (TPS). The (TPS) is a device that sends an electrical signal to the Electronic Control Module (ECM) that varies in voltage, depending on how low the pedal is depressed. The system is installed in the space normally occupied by the mechanical foot pedal. The (EFPA) has maximum and minimum stops that are built into the unit during manufacturing (Fig. 10).

The (TPS) converts the operator's foot pedal input into a signal for the ECM. The (EFPA) is shown in Figure 10.

When installed by the equipment manufacturer, the TPS should not require adjustment. If the TPS is suspected of being misadjusted, confirm that the sensor is installed in accordance with the manufacturer's specifications. It is recommended that the idle count be at 50 or higher with a full throttle count of up to 200.

The TPS is self-calibrating and therefore has no optimum closed throttle or wide open throttle count value. If the counts are within the 50 to 200 range, the sensor is properly set.

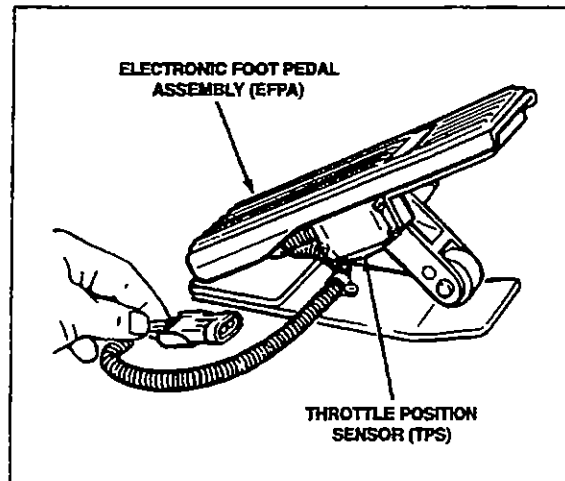

Figure 10: Electronic Foot Pedal Assembly 01026

Monitor the (TPS) as the controls move it through its full stroke. Be sure there is no misalignment or obstruction preventing the smooth movement of the TPS through the full stroke. Using a diagnostic data reader, check that the idle and full throttle position counts do not fall within the error zones. The error zones occur when the idle position is less than 14 counts, or when the full throttle position is more than 233 counts. Should these conditions occur, the ECU will signal diagnostic codes of 21-12 for idle error and 21-23 for wide open throttle error.

### 3.3 Cruise Control Switches (CCS)

The four cruise control switches are located in the driver's area on the L.H. side control panel.

1. **Cruise On/Off:** This is the main switch that actuates the ECM memory in order to use the speed regulating mode.
2. **Cruise Set:** This switch is used to set the cruise control speed or to decrease the set speed by 2 MPH at each application.

## Section 01: Engine

**Note:** Cruise control system will not accept speed settings, nor will the "Resume" switch operate below 20 mph (32 km/h) and the engine speed must be above 1100 RPM.

3. **Cruise Resume:** Each time this switch is actuated, the speed will be increased by 2 mph (3,5 km/h). This switch allows the driver return to the last regulated speed following a brake or "DECEL" switch application.

**Note:** On-off switch must be in the "ON" position in order to return to the last regulated speed.

4. **Cruise Decel:** Will cancel the cruise temporarily like a brake application but without actuating brake light. Set speed is still in memory for resume.

For additional information, see your "Operator's Manual"

### 3.4 Diagnostic System Accessories (DSA)

The DDEC III engine Diagnostic System Accessories include the following:

- Check Engine warning light;
- Stop Engine warning light;
- Stop Engine Override switch; and
- Diagnostic Data Link (DDL) connectors.

1. **Check Engine Warning Light:** This light, mounted on the central dashboard panel, illuminates to indicate that a problem is currently being detected and that a code has been stored in the ECM memory. This light also has a 5-second bulb check when the ignition is first turned on. The Check Engine Light illuminates when the temperature at coolant sensors exceeds 217°F (103°C) and the temperature at oil sensors exceeds 260°F (127°C). When sensors reach those temperatures, engine power starts to decrease linearly.

2. **Stop Engine Warning Light:** This light, also mounted on the central dashboard panel, illuminates to indicate that a major engine problem is occurring (with the exception of a 5-second bulb check when the ignition is first turned on). The Stop Engine Light illuminates when temperature at coolant sensors exceeds 222°F (106°C) and the temperature at oil sensors exceeds 239°F (115°C). When sensors reach those temperatures, the engine will shut down after 30 seconds. This 30-second delay period may be repeated using the OVERRIDE switch.

**Note:** Once engine is stopped, it can not be restarted until the malfunction is corrected.

3. **Stop Engine OVERRIDE Switch:** This switch, mounted on the L.H. lower control panel, is used when the Stop engine warning light is illuminated. Push down the switch to allow a 30-second delay period (non cumulative) in the shutdown procedure. This switch can be repeatedly depressed, i.e. one (1) pulse is sufficient for each 30 second period, in order to move the vehicle out of traffic.

**Note:** The stop engine override switch will be operative only if it has been depressed before the end of the 30 second delay period.

**Caution:** The OVERRIDE switch must be used only in emergency cases, such as to move the vehicle out of traffic. Excessive use of this switch could cause serious damage to the engine.

4. **Diagnostic Data Link (DDL) Connectors:** A connector is mounted on the L.H. Lower Control Panel. Another connector is located in the rear electric compartment. They allow to connect the Diagnostic Data Reader (DDR) and to read the codes or to access pertinent data on the engine condition. This enables a more complete analysis of any defect found in the DDEC system operation. For more information, see Detroit Diesel Troubleshooting Guide #6SE492.



## 4. DDEC III DIAGNOSTIC CODES

### 4.1 Reading Diagnostic Codes - Flash Method:

DDEC III makes use of two types of codes: Active and inactive. The difference between the two types of codes are as follows:

1. **Active Codes:** These are the codes which are currently keeping the Check Engine or Stop Engine light illuminated. Active codes are flashed via the Stop Engine Light when checked with override switch.
2. **Inactive Codes:** These are all the codes logged in the ECM (whether or not they are currently turning on the Stop or Check Engine Light). Inactive codes are flashed via the Check Engine light when checked with override switch.

In most instances, only the DDR can provide the information necessary for a quick diagnosis of the problem. If you just need to read out codes, however, and do not have a DDR available, the following procedure will let you read out codes. Make sure the rear starting switch (located in the engine compartment) is in the normal position. Momentarily depress the Stop Engine Override switch (located on the L.H. lower control panel) with the ignition ON, the engine idling or engine shut-off. Active codes will be flashed on the stop engine telltale (located on the central dashboard), followed by the inactive codes being flashed on the check engine telltale (located on the central dashboard). The cycle repeats itself until the operator depresses the Stop Engine Override Switch. A code "43" consists of four flashes, followed by a short pause, then three flashes in quick succession.

## 4.2 DDEC III Diagnostic Codes List

DDC Code Number (Flashed)	Description	DDC Code Number (Flashed)	Description
11	Variable speed governor sensor voltage low	12	Variable speed governor sensor voltage high
13	Coolant level circuit failed low	14	Intercooler temperature circuit failed high
14	Coolant temperature circuit failed high	14	Oil temperature circuit failed high
15	Intercooler temperature failed low	15	Coolant temperature circuit failed low
15	Oil temperature circuit failed low	16	Coolant level circuit failed high
17	Bypass position circuit failed high	18	Bypass position circuit failed low
21	EFPA circuit failed low	22	EFPA circuit failed low
23	Fuel temperature circuit failed high	24	Fuel temperature circuit failed low
25	Reserved for "no codes"	26	Aux. shutdown #1 active
26	Aux. shutdown #2 active	27	Air temperature circuit failed high
28	Air temperature circuit failed low	31	Aux. output #3 open circuit (high side)
31	Aux. output #3 short to ground (high side)	31	Aux. output #4 open circuit (high side)
31	Aux. output #4 short to ground (high side)	32	SEL open circuit
32	SEL short to battery	33	Turbo boost pressure circuit failed high
34	Turbo boost pressure circuit failed low	35	Oil pressure circuit failed high
36	Oil pressure circuit failed high	37	Fuel pressure circuit failed high
38	Fuel pressure circuit failed low	41	Too many SRS (missing TRS)
42	Too few SRS (missing SRS)	43	Coolant level low
44	Intercooler temperature high	44	Coolant temperature high
44	Oil temperature high	45	Oil pressure low
46	Battery voltage low	47	Fuel pressure high

## Section 01: Engine

DDC Code Number (Flashed)	Description	DDC Code Number (Flashed)	Description
48	Fuel pressure low	52	A/D conversion fail
53	Nonvolatile checksum incorrect	53	EEPROM write error
54	Vehicle speed sensor fault	55	J1939 data link fault
55	Proprietary link fault (master)	55	Proprietary link fault (receiver)
56	J1587 data link fault	57	J1922 data link fault
58	Torque overload	61	Response time long
62	Aux. output #1 short to battery	62	Aux. output #1 open circuit
62	Aux. output #2 short to battery	62	Aux. output #2 open circuit
62	Aux. output #5 short to battery	62	Aux. output #5 open circuit
62	Aux. output #6 short to battery	62	Aux. output #6 open circuit
62	Aux. output #7 short to battery	62	Aux. output #7 open circuit
62	Aux. output #8 short to battery	62	Aux. output #8 open circuit
63	PWM #1 short to battery	63	PWM #1 open circuit
63	PWM #2 short to battery	63	PWM #2 open circuit
63	PWM #3 short to battery	63	PWM #3 open circuit
63	PWM #4 short to battery	63	PWM #4 open circuit
64	Turbo speed circuit failed	65	Reserved for air filter differential pressure circuit failed high
65	Reserved for air filter differential pressure circuit failed low	66	Reserved for oil filter differential pressure circuit failed high
66	Reserved for oil filter differential pressure circuit failed low	67	Coolant pressure circuit failed high
67	Coolant pressure circuit failed low	68	Idle validation circuit fault (grounded circuit)
68	Idle validation circuit fault (open circuit)	71	Injector response time short
72	Vehicle overspeed	72	Reserved for vehicle overspeed (absolute)
73	Reserved for air differential pressure high	74	Oil differential pressure high

**Section 01: Engine**

<b>DDC Code Number (Flashed)</b>	<b>Description</b>	<b>DDC Code Number (Flashed)</b>	<b>Description</b>
75	Battery voltage high	76	Engine overspeed with engine brake
77	All other faults not listed	81	Timing actuator (dual fuel) failed high
81	Oil level circuit failed high	81	Crankcase pressure circuit failed high
82	Timing actuator (dual fuel) failed low	82	Oil level circuit failed low
82	Crankcase pressure circuit failed low	83	Oil level high
83	Crankcase pressure high	84	Oil level low
84	Crankcase pressure low	85	Engine overspeed
86	Pump pressure circuit failed high	86	Barometric pressure circuit failed high
87	Pump pressure circuit failed low	87	Barometric pressure circuit failed high
88	Coolant pressure low	--	CEL short to battery
--	CEL open circuit	--	Clock Module failure
--	Clock module abnormal rate		

## 5. ENGINE OIL LEVEL

Check the oil level daily with the engine stopped. If the engine has just been stopped and is warm, wait at least 10 minutes to allow the oil to drain back to the oil pan before checking. Wipe the dipstick clean, then check oil level. The level should always be within the safe range on the dipstick (Fig. 11) . Add the proper grade of oil to maintain the correct level on the dipstick. All diesel engines are designed to consume some oil, so a periodic addition of oil is normal.

**Warning:** Touching a hot engine can cause serious burns.

**Caution:** Do not overfill. Oil may be blown out through the crankcase breather if the crankcase is overfilled.

**Caution:** Clean end of tube before removing the dipstick to prevent oil contamination.

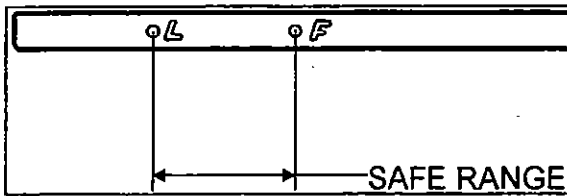

Figure 11: Engine Oil Level Dipstick 01027

**Caution:** If the oil level is constantly above normal and excess lube oil has not been added to the crankcase, consult with an authorized Detroit Diesel service outlet for the cause. Fuel or coolant dilution of lube oil can result in serious engine damage.

The vehicle is provided with an oil reserve tank in the engine compartment which is used for the engine. To adjust oil level, open the oil reserve tank valve and allow oil to discharge into the engine until reaching the "Full" mark on the dipstick, then close the valve. Check oil reserve tank level through the level sight tube on the side of the tank and pour oil in the reserve tank if necessary (Fig. 12).

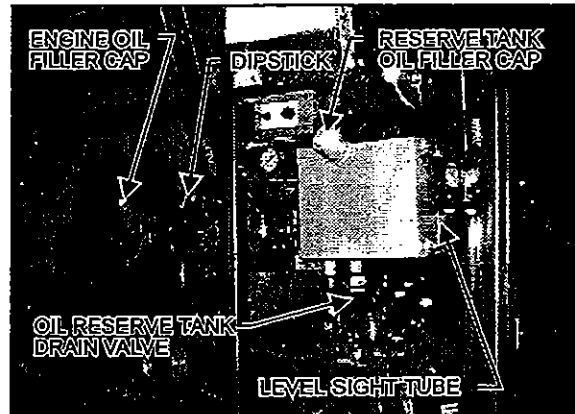

Figure 12

01028

## 6. ENGINE OIL AND FILTER CHANGE

Both the oil and filter should be changed every 12,500 miles (20 000 km) or once a year, whichever comes first. However, more frequent changes may be required when the engine is subject to high level of contamination and/or overheating. Change intervals may be decreased or gradually increased with experience on specific lubricants until the most practical service condition has been established. Always refer to the lubricant manufacturer's recommendations (analysis of drained oil can be helpful).

**Caution:** Do not use solvent to dilute the engine oil when draining oil. Dilution of the fresh oil can occur which may be detrimental to the engine.

Change engine oil with the vehicle on a flat and level surface and with the parking brake applied. It is best to drain the oil when the engine is still warm.

1. From under the vehicle, remove the engine drain plug on the oil pan. Allow oil to drain (Fig. 13).

## Section 01: Engine

**Warning:** Hot engine oil can cause serious burns. Wear coveralls with sleeves pulled down and gloves to protect hands.

2. Reinstall the drain plug.

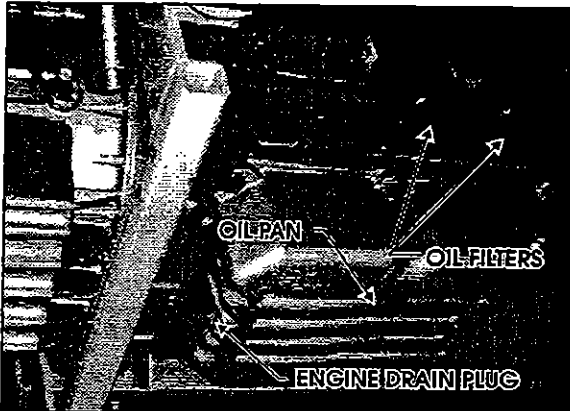

Figure 13

01029

3. Remove the spin-on filter cartridge using a 1/2" drive socket wrench and extension.
4. Dispose of the used oil and filter in an environmentally responsible manner in accordance with state and/or federal (EPA) recommendations.
5. Clean the filter adaptor with a clean rag.
6. Lightly coat the filter gasket (seal) with clean engine oil.
7. Install the new filter on the adaptor and tighten manually until the gasket touches the mounting adaptor head. Tighten full-flow filters an additional two-thirds of a turn manually. Then, tighten bypass filter one full turn manually.

**Caution:** Overtightening may distort or crack the filter adaptor.

8. Remove the engine oil filler cap and pour oil in the engine until it reaches the "FULL" mark on the dipstick (Fig.12).
9. Start and run the engine for a short period and check for leaks. After any leaks have been corrected, stop the engine long enough for oil from various parts of the engine to drain back to the crankcase (approximately 20 minutes).

Add oil as required to bring the level within the safe range on the dipstick (Fig. 11).

## 7. RECOMMENDED ENGINE OIL TYPE

To provide maximum engine life, lubricants shall meet the following specifications:

SAE Viscosity Grade: 15W-40  
API Classification: CF-4  
HT/HS Viscosity: 3.7 cP minimum

**Note:** Monograde oils should not be used in these engines regardless of API Service Classification.

**Note:** The use of supplemental oil additives are discouraged from use in Detroit Diesel Engines.

### Synthetic oils

Synthetic oils may be used in Detroit Diesel engines provided they are API licensed and meet the performance and chemical requirements of non-synthetic oils outlined previously. Synthetic oils does not permit extension of recommended oil drain intervals.

### Lubricant Selection World Wide

Oils meeting API CD or CC specifications may be used if they also meet military specification MIL-L-2104 D or E. Oil which meet European CCMC D4 specifications may also be used. Modification of drain interval may be necessary, depending on fuel quality. Contact Detroit Diesel Corporation for further guidance.

## 8. WELDING PRECAUTION

**Caution:** Precautions must be taken to prevent damage to the DDEC electronic control system when welding. Disconnect battery power, ground cables and the 6-pin power connector at the ECM (Electronic Control Module) before welding. Failure to isolate the DDEC system from high current flow can result in severe ECM damage.

## 9. POWER PLANT ASSEMBLY REMOVAL (AUTOMATIC AND MANUAL)

To access the engine or engine-related components, the vehicle power plant assembly must be removed as a whole unit by means of a slide-out cradle. The power plant assembly includes the engine, transmission (including retarder if so equipped), air compressor, alternator and transmission oil cooler.

Remove the power plant assembly as follows:

**Caution:** Tag hoses and cables before disconnecting in order to facilitate reinstallation. Plug all openings to prevent dirt from entering the system.

**Note:** No parts within the ECM are serviceable. If found defective, replace the complete ECM unit.

1. Disconnect the battery or batteries from the starting system by removing one or both of the battery cables from each battery system. With the electrical circuit disrupted, accidental contact with the starter button will not produce an engine start. In addition, the Electronic Unit Injectors (EUI) will be disabled, preventing any fuel delivery to the injector tips.

**Warning:** Due to the heavy load of the rear bumper assembly, it must be adequately supported before attempting to remove it.

2. Remove the rear bumper assembly from the vehicle. Refer to Section 18, Body, under heading "Rear Bumper Removal and Installation".
3. Drain the engine cooling system. Refer to Section 05, Cooling under heading "Draining Cooling System".



Figure 14

05035

4. Locate the belt tensioner control valve (Fig. 14). Turn handle counterclockwise in order to reverse pressure in belt tensioner air bellows and release tension on belts. Remove belts.
5. Exhaust all air from the air system. (if necessary, refer to Section 12, Brakes & Air System).

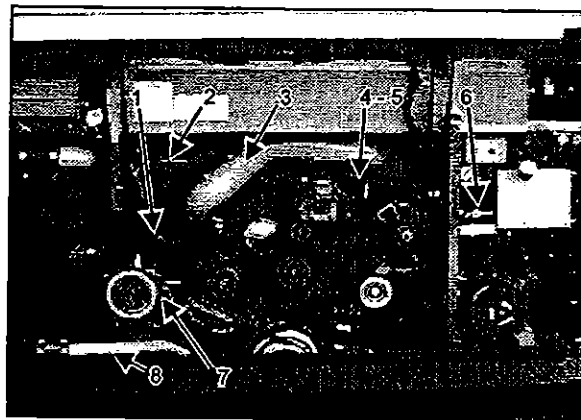

Figure 15

01030

6. Disconnect and remove the engine air intake duct mounted between air cleaner housing and turbocharger inlet (3, Fig 15).

## Section 01: Engine

**Caution:** To avoid damage to turbocharger, cover the turbocharger inlet opening to prevent foreign material from entering.

7. Disconnect and remove the air intake duct mounted between the air cooler outlet and the intake engine (2, Fig. 15).

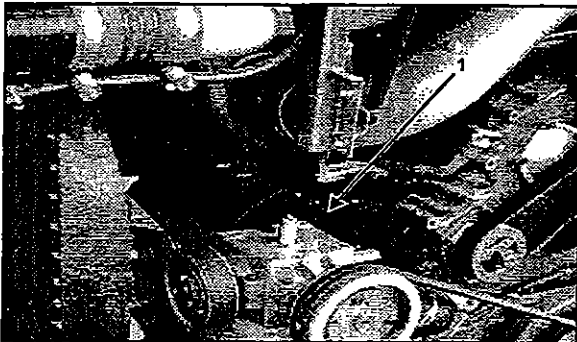

Figure 16

01031

8. Disconnect and remove section of coolant pipe assembly mounted between the radiator outlet and the water pump inlet (8, Fig. 15).
9. Disconnect the coolant delivery hose located inside of engine close to the water pump.
10. Disconnect the connector for electric fan clutch close to the water pump (1, Fig. 16).
11. Dismantle the air bellow of the upper bracket tensioner for the fan drive assembly. Remove the upper bracket (7, Fig. 15).
12. If necessary, remove the fan drive of the motor compartment by removing the four retaining bolts, washers and nuts securing the fan drive to the radiator floor.
13. Disconnect and remove the air intake duct mounted between the turbocharger outlet and the air cooler inlet.
14. Disconnect two vent hoses from the thermostat housing and from the coolant pipe assembly.
15. Disconnect and remove section of coolant pipe assembly mounted between the thermostat housings and the radiator inlet.
16. Disconnect and remove the small hose connected to the heater line valve and to the water pump.
17. Disconnect the small heater hose located on the cylinder head at the back of the engine.
18. Disconnect temperature sensor for the pyrometer located above the exhaust pipe, close to the turbocharger (optional).
19. Disconnect and remove the exhaust pipe mounted between the turbocharger outlet and the exhaust bellows. If necessary, refer to Section 4, under heading "Exhaust System".

**Caution:** To avoid damage to turbocharger, cover the turbocharger outlet opening to prevent foreign material from entering.

20. Disconnect the block heater connector above the power steering pump (on the right side).
21. Disconnect the steel-braided air line from the A/C compressor air bellows.
22. Disconnect the engine oil pressure steel-braided hose from the mechanical oil pressure gauge and the cable of the gauge water temperature (4 and 5, Fig. 15).
23. Disconnect the oil delivery hose from the valve located at the reserve tank exit.



24. Disconnect the power steering pump supply and discharge hoses. Cap hose openings immediately to limit fluid loss. Remove retaining clips from cradle.
25. Close engine fuel supply shutoff valve on primary fuel filter. Disconnect the fuel line connected to inlet port. On vehicles equipped with the optional water separator fuel filter, disconnect the connector and remove cable ties from cradle.
26. Disconnect the air compressor discharge, governor steel-braided air lines and the manual filling air lines from compressor. Remove retaining clips.
27. Disconnect the hose connecting the compressor head to the septic reservoir.
28. Disconnect ground cables from rear subframe ground stud, located close to the starting motor.
29. Disconnect positive cable (red terminal) from starting motor solenoid.
30. Disconnect the power plant wiring harness main connectors from EMC and remove retaining clips from engine compartment back wall.
31. On vehicles equipped with an automatic transmission provided with a hydraulic output retarder, disconnect steel-braided air line from pressure regulator output. The pressure regulator is mounted in the upper section of engine compartment back wall.
32. Disconnect fuel return line from bulk head fixed on engine cylinder head end.
33. On vehicles equipped with an electrically operated cold starting aid, disconnect the delivery hose from the starting aid cylinder solenoid valve. Remove cable ties securing hoses.
34. Disconnect turbo boost pressure gauge air line (if vehicle is so equipped) from engine air intake.
35. (Only if the vehicle is equipped with a retarder). Remove the transmission rubber damper assembly above transmission by removing: nut, bushing, rubber damper, rubber damper guide, bolt and washer. Remove the rubber damper bracket from transmission
36. Disconnect connectors from transmission. On the left side, four on rear side with one close to yoke. On right side, look close to the solenoid valve of the output retarder.
37. From under the vehicle, disconnect the propeller shaft as detailed in Section 09, under heading "Propeller Shaft".

### Manual Transmission:

- Disconnect gear shift linkage.
  - Remove clutch slave cylinder from transmission without disconnecting the hydraulic hose.
38. Inspect the power plant assembly to ensure that nothing will interfere when sliding out the cradle.
  39. Remove the six retaining bolts, washers and nuts securing the power plant cradle to the vehicle rear subframe (Fig. 18).

**Note:** Check if any spacer(s) have been installed between power plant cradle and vehicle rear subframe, and if so, note position of each washer for reinstallation purposes.

## Section 01: Engine

- Using a forklift, with a minimum capacity of 4,000 lbs (1 800 kg), slightly raise the power plant cradle. Pull engine out slowly from the engine compartment. Make sure all lines, wiring and controls are disconnected and are not tangled.

**Caution:** Due to the minimum clearance between the power plant equipment and the top of the engine compartment, extreme care should be used to raise the power plant cradle, just enough to free the cradle. Clearance between power plant cradle and mounting rail should range between 1/4" and 1/2" (6-12 mm).

## 10. POWER PLANT ASSEMBLY INSTALLATION (Automatic and Manual)

To install a power plant assembly, follow the same procedure as in "9. Power Plant Assembly Removal" except in a reverse order. Then proceed with the following:

- Torque the power plant cradle mounting bolts to 113-144 lbf·ft (153-195 N·m).
- (only if the vehicle is equipped with an automatic transmission and a retarder).
  - Install the bracket from transmission (torque screw to 71-81 lbf·ft [96-110 N·m]).
  - Install the transmission rubber damper assembly above transmission by assembling: bolt, washer, rubber damper guide, rubber damper, bushing and nut. Respect rubber damper tolerance (Fig. 17).

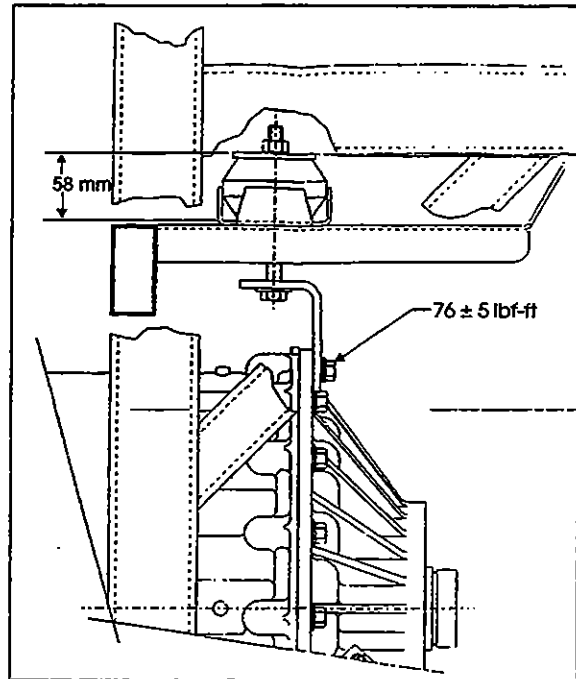

Figure 17: Rubber Damper Tolerance

07014

- If fan drive has been removed, reinstall and align as per Section 05, Cooling System, under heading "Fan Drive Alignment".
- Refill cooling system with saved fluid (refer to Section 05, Coolant System).
- After engine fuel system has been drained, it will aid restarting if fuel filters are filled with fuel oil (refer to Section 03, Fuel System).
- After work has been completed start engine for a visual check. Check fuel, oil, cooling, pneumatic and hydraulic system connections for leakage. Test operation of engine controls and accessories.

## 11. ENGINE MOUNTS

The power plant assembly is mounted to the cradle by means of four rubber mounts on a vehicle powered with a series 60 engine.

Two rubber mounts are used at the front of the engine while other two are mounted on each side of the flywheel housing, on vehicles equipped with automatic and manual transmissions (Fig.18).

It is recommended that new rubber mounts be installed at each major overhaul.

## 12. JAKE BRAKE

Refer to both "The Jake Brake Troubleshooting and Maintenance Manual" and "Installation Manual for Models 760/760A/765 Engine Brakes" for troubleshooting and installation procedures. They are annexed to the end of this section.

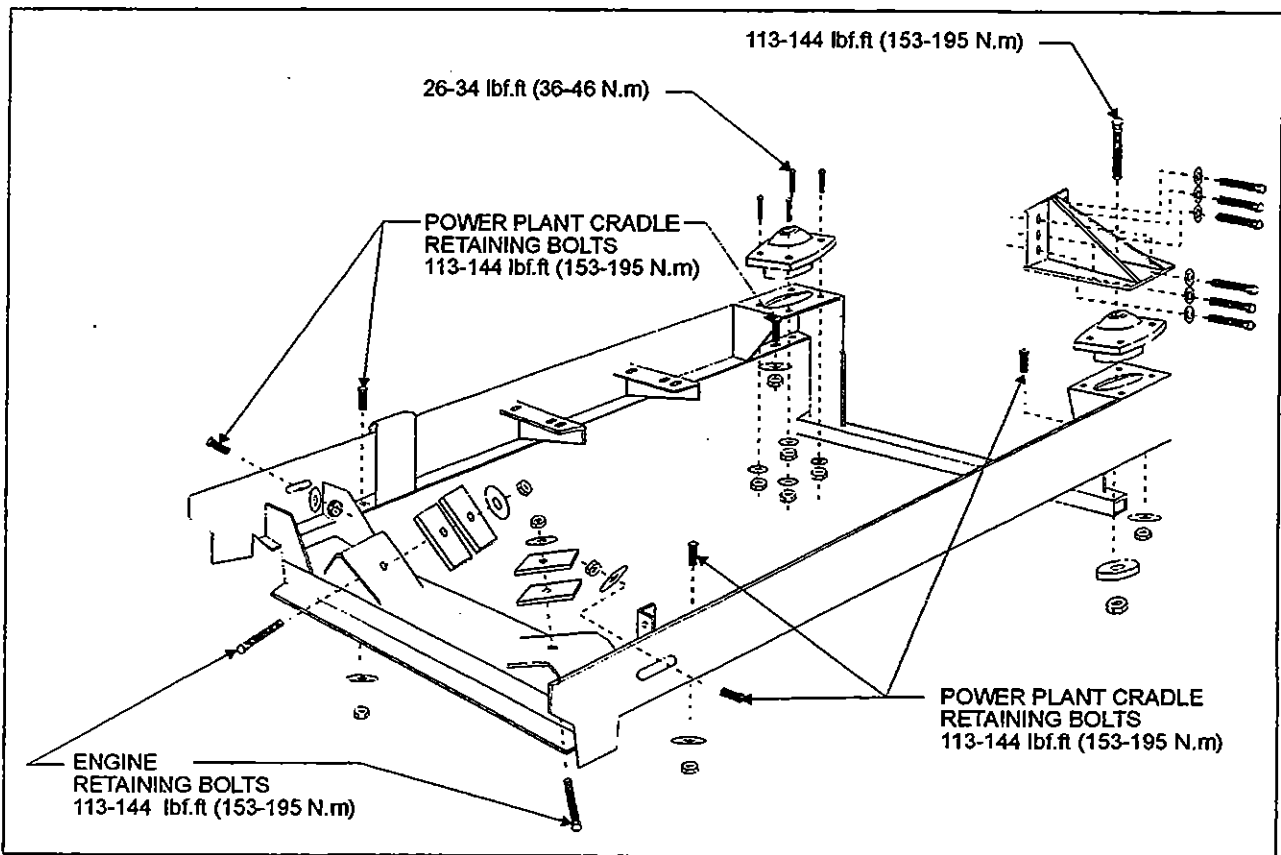

Figure 18: Power Plant Cradle Installation

01032

### 13. SPECIFICATIONS

Make ..... Detroit Diesel  
 Type ..... Diesel four cycle/in-line engine  
 Description ..... Turbo/Air to air charge cooled  
 No. of cylinders ..... 6  
 Operating range ..... 1200-2100 RPM  
 Maximum RPM ..... 2100

**Model 11.1 Liter**

Bore & Stroke ..... 5.12 X 5.47 in (130 X 139 mm)  
 Horsepower Range ..... 300-365 BHP

**Model 12.7 Liter**

Bore & Stroke ..... 5.12 X 6.30 in (130 X 160 mm)  
 Horsepower Range ..... 370-470 BHP

**Lubricant**

Heavy-duty engine oil SAE Viscosity Grade 15W-40, API Classification CF-4, HT/HS Viscosity 3.7 cP and meeting MIL-L-2104 D or E specifications. Synthetic oil may be used if it meets the performance and chemical requirements of non-synthetic oils outlined previously. Some engine operating conditions may require exceptions to this recommendation.

**Capacity**

Oil reserve tank ..... 10 US qts (9.5 L)

**Engine oil level quantity**

26 quarts to the LOW mark ..... Without oil filters  
32 quarts to the FULL mark ..... Without oil filters  
41 quarts to the LOW mark ..... With oil filters installed

**Lubricating oil filter elements**

Make ..... AC Rochester Div. GMC # 25014505  
Make ..... A/C Filter # PF-2100  
Type ..... Full Flow  
Prevost number ..... 51-0458

**Torque specification**

Engine oil filter ..... Tighten 2/3 of a turn after gasket contact





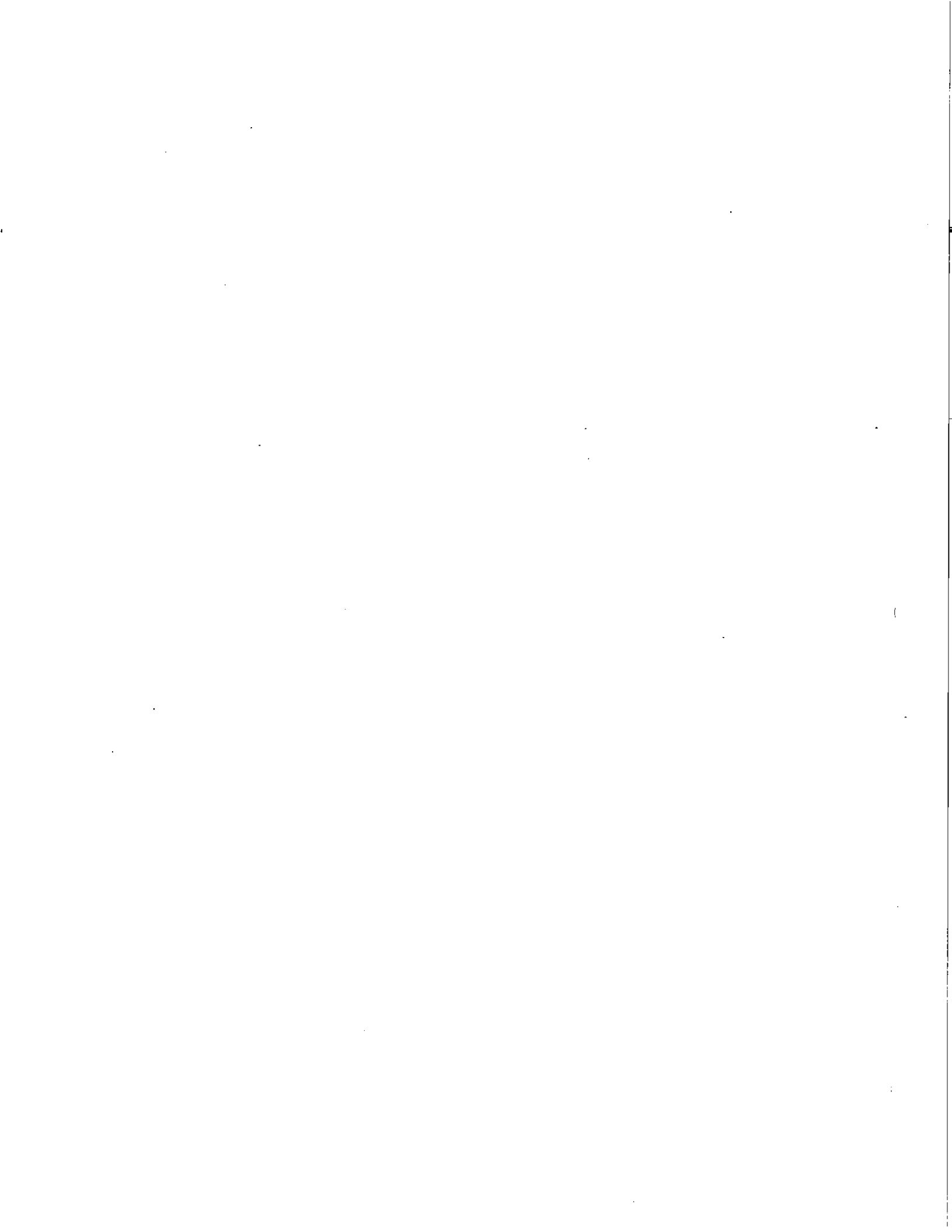



# DETROIT DIESEL



## SERIES 60 Service Information

NUMBER: 11-60-95

S.M. REF.: 13.9.1

ENGINE: 60

DATE: March 1995

### SUBJECT: CG-4 LUBRICATING OILS RECOMMENDED

#### INTRODUCTION

In January of 1995, the API (American Petroleum Institute) began voluntary licensing of API Service CG-4 lubricating oils for use in on-highway truck engines. To conform with this change, Detroit Diesel now recommends the use of CG-4 oils in Series 60 engines.

#### DETAILS AND REASON

Oils meeting the new CG-4 classification were developed for on-highway, emission-controlled engines operating on low sulfur fuel in applications where API CF-4 lubricants were formerly used. To conform with this API licensing change, Detroit Diesel now recommends the use of CG-4 oils in Series 60 engines and in all other DDC four-cycle products.

#### NOTICE:

To avoid possible engine damage, do not use single grade (monograde) lubricants in Detroit Diesel four-cycle Series 50 and 60 engines, regardless of API classification.

The recommended viscosity grade continues to be 15W-40. See Figure 1 for the API symbol required on CG-4 lubricants.

#### SERVICE

The phase-in of API CG-4 oils will not be immediate. Therefore, API CF-4 lubricants may continue to be used until CG-4 products become available. The use of CG-4 oils does not permit extension of oil drain intervals. Required oil drain and filter change intervals *must* be strictly observed when using either CG-4 or CF-4 lubricants.

For oil drain intervals and additional information on lubricating oils, refer to publication 7SE270, *Engine Requirements: Lubricating Oil, Fuel, and Filters*, available from authorized Detroit Diesel Distributors.

#### ADDITIONAL SERVICE INFORMATION

Additional service information is available in the Detroit Diesel *Series 60 Engine Service Manual*, 6SE483. The next revision to the *Series 60 Engine Service Manual* will include this information.

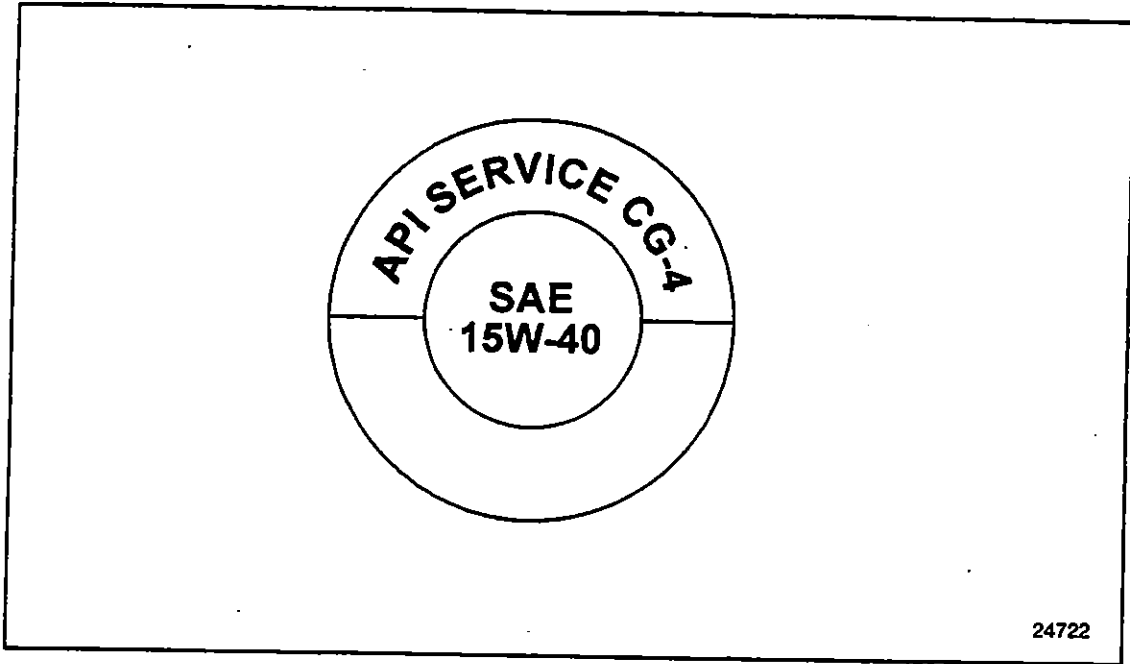

FIGURE 1 API Symbol



13400 Outer Drive, West / Detroit, Michigan 48239-4001  
Telephone: 313-592-5000  
FAX: 313-592-7288

## **SERIES 60 FEATURES AND BENEFITS**

The Series 60 Engine. Designed and manufactured by Detroit Diesel Corporation for the North American Heavy Duty truck market. Let's look at the Features and Benefits the Series 60 engine makes available to you as a customer in today's demanding trucking industry.

The Series 60 engine is a 4 cycle in-line 6 cylinder diesel engine with integral electronic controls. It is the most advanced on-highway heavy duty diesel engine in the market today. The design started in 1980 with a desire to develop a fully electronic controlled diesel engine that would take the trucking industry through the 90's and beyond.

That is why the Series 60 engine is a completely new design and not an attempt to rework an existing product.

Detroit Diesel listened to the customers needs, looked at the future stringent emission standards, and added their own objectives during the development stages of the Series 60 engine. They quickly realized that improvements on existing technology and the development of new technology was necessary to meet their objectives.

The end result is an Electronically controlled governing system that helps the Series 60 engine meet the stringent emission regulations of the 1990's and beyond. The simplistic design and dependable electronic controls improve reliability, durability, and offer reduced engine maintenance.

Detroit Diesel offers the Series 60 with two (2) engine displacements. The 11.1 liter and 12.7 liter versions. Both displacements have the same cylinder diameter with a longer piston stroke for the 12.7 liter engine. The horsepower range of the Series 60 is from the 11.1 liter at 285 hp to the 12.7 liter at 450 hp.

Both the 11.1 liter and the 12.7 liter look physically the same because they both use the same external parts like the cylinder block, the cylinder head, the rocker cover and oil pan. In fact there are only eight parts that are different between the 285 hp 11.1L and the 450 hp 12.7L engine.

Those parts include the crankshaft, connecting rod, oil cooler, vibration damper, and crankshaft gear to build the larger bore engine, with different camshaft, injectors, and turbocharger for engine performance.

Each engine displacement has two (2) families of engine power ratings. The 11.1 liter ratings are from 285 to 350 hp, while the 12.7 liter ratings are from 365 to 450 hp.

With-in an engine family the horsepower can be changed by reprogramming the ECM. The cost for this programming change is minimal and can increase the residual value of the vehicle. Just contact your local Detroit Diesel Distributor for the simple re-programming of the electronic control module. Make sure the engine support systems such as the radiator and drive train components have sufficient capacity to handle any increased horse power and peak torque changes.

Now lets look at a performance curve of the Series 60 engine. Here is an 11.1 liter, 320 hp, 1800 RPM engine. Notice the engine peak torque is at 1200 RPM's. Also notice that the fuel curve stays almost flat throughout the operating range of the engine. This feature offers more consistent fuel economy throughout the engine performance range, a wider operating range for the truck, and less shifting for the driver.

The electronic engine control offers cruise control similar to a passenger car. Detroit Diesel expanded this feature to offer Cruise Power. This feature offers engine horse power chosen for normal truck operation and a higher horsepower during the cruise control operation.

For example, the 11.1 liter offers a 320/350 hp cruise power option. This means that 320 hp is available during normal engine operations and 350 hp is available while operating in cruise control. This option gives the driver more power for climbing hills, more power for fighting head winds, and more power means less shifting. Feed back from the drivers indicate they really like this feature and operating the vehicle in cruise control promotes better fuel economy.

As you know the Series 60 has a reputation for being an efficient and reliable engine. Some physical features which contribute to this success include:

**Air to air charge cooling.** Cooler, denser intake air helps engine efficiency.

The **cylinder block** has a simple, clean design. This design includes serpentine external walls for noise reduction. The absence of push rod cavities in the block allows for a more evenly spaced bolt hole pattern around each cylinder bore. This gives the engine a more uniform cylinder head bolt clamp load.

The **cylinder head** is a one piece casting. It holds the overhead camshaft, the thermostats, and provides more rigidity to the cylinder block. The 38 cylinder head bolts create 1,000,000 lbs clamp load to the cylinder head gasket. The fire deck of the cylinder head has machined slots between the cylinders to provide thermal stress relief.

The **overhead camshaft** eliminates the need for push rods and related hardware. The sturdy rocker arm assemblies operate directly off the camshaft making it possible to have very high fuel injection pressures. These high injection pressures are necessary for maximum fuel economy and reducing engine exhaust emissions. However, engines with push rods also require higher injection pressures to meet today's stringent emission standards.

The **crankshaft** is very strong, is very durable, and has the largest main and rod bearing journal diameters of any diesel engine manufactured in the United States. For this reason, the rod bearings and main bearings do not have a recommended change interval. Under normal operating conditions the bearings will last until engine overhaul.

The **piston assembly** is a Detroit Diesel cast iron cross-head, two piece design. The fire ring groove is near the top of the piston to minimize dead space during combustion. The piston assembly has a dome, a skirt, a piston pin and piston pin bearing. The top two rings are keystone design to prevent sticking. The skirt has tin plating to assist break-in and eliminate scuffing during test. The piston pin holds the entire assembly together with the connecting rod bolted directly to the pin.

**Jacobs Manufacturing** designed an engine brake specifically for the Series 60 engine. The braking system is electrically linked to the electronic control Module, and offers responsive and excellent braking performance to the driver.

A very important component in the Series 60 engine is the **electronic unit injector**. Detroit Diesel used a mechanical unit injector since they started building engines in 1938. It was redesigned to include a solenoid which operates a valve inside the injector. The valve will regulate fuel injection duration and injection timing with electrical commands from the Electronic Control Module or ECM.

Diagnosing the injector is simple with the ECM and a hand held Diagnostic Data Reader or a DDR. Using this equipment will eliminate any guess work as to the performance of any injector in the engine.

Some additional premium features of the Series 60 engine include the use of **grade eight (8)** cylinder head bolts, durable **roller bearings** for the accessory drives, **silicone hoses** for the cooling system, and **viton o-rings** to seal between the liner and block and the injector tube areas of the engine. The block and head casting are also **pre-painted** to maintain a clean and rust free engine appearance.

As you can see the Series 60 is truly a world class diesel engine that incorporates state of the art technology and assembly procedures. Now let's look at the other major contributing factor that makes the Series 60 engine so successful. The Detroit Diesel Electronic Control system.

The DDEC system consists of the ECM, the Electronic unit injectors, various engine mounted sensors, a coolant level sensor in the radiator, and an electronic foot pedal assembly located in the Vehicle. The ECM micro processor will compile data from the sensors and control engine operation as conditions change for maximum engine performance.

These are the engine sensors that the ECM uses to maintain engine performance. Notice that DDEC monitors fuel temperature, oil temperature, and the engine coolant level. The Turbo boost sensor monitors boost to control engine acceleration smoke.

Another feature of the DDEC system is the programmable options available to the customer. These options include:

- ★ **Engine protection shutdown features,**
- ★ **Programmable governor RPM droop** which makes the engine more driver friendly.
- ★ **Engine idle time from 1 to 100 minutes.** When activated this option can help reduce fuel costs and engine wear from excessive idling.
- ★ **High engine idle** is available with a PTO switch or with the cruise control switch system. In this mode DDEC is a variable speed governor throughout the engine operating range.
- ★ **Road speed governing and Cruise control** tailor the vehicle road speed to the customers needs. DDEC will calculate vehicle speed from the axle ratio, transmission top gear ratio, tire revolutions per mile, and vehicle speed sensor. From these calculations DDEC can now control the vehicle road speed while operating in high gear. Cruise Control is available in all gears above 1200 engine RPM.

The DDEC system offers many benefits to you as a customer. These benefits include:

**An Engine protection feature** that stops a running engine when sensors detect a condition that could cause engine damage. A red stop engine light and a yellow check engine light on the vehicle instrument panel will appear while DDEC will identify the problem with a code logged in its non-volatile memory. An audible warning system may be available from your OEM.

The **ECM diagnostics** offer: an active code display from the DDR with a check engine warning light on the vehicle dash board, Historical diagnostic codes stored in non-volatile memory for future retrieval, Engine performance checks, injector cylinder cutout, and an active engine sensor data display from the DDR. **DDEC Reduces Maintenance** by eliminating the high and low idle spring adjustments of a mechanical governor, the adjustments of smoke control devices like throttle delay or fuel modulator, the injector rack adjustment, the governor gap settings, compensations for mechanical governor wear, and adjustments with mechanical throttle linkage connections.

The **DDR** will also display the basic engine data such as engine serial number or the programmable option features of the engine. (26) The DDR hardware includes a housing with a liquid crystal display and a removable cartridge for any custom EPROM upgrades to the DDEC software system.

The **engine protection** feature of the DDEC system will shut the engine down in 30 seconds if the radiator coolant level is too low, if the oil pressure is too low for the engine speed or, if the oil temperature is too high. Should one of these conditions occur, the historical data will record the engine hours of the first occurrence, the number of occurrences, and the total time the engine ran in this condition.

During the engine shutdown sequence the driver can use an engine shutdown override switch. This switch gives the driver a repeatable thirty seconds to move the vehicle into a safe location. However, the historical data will reveal how many times the driver used the override switch.

**Reprogramming, upgrading or changing engine performance** is a very simple procedure with the DDEC system. Just contact your local Detroit Diesel Distributor. From their location they can access the main frame computer which stores the DDEC engine calibrations of every Detroit Diesel engine. The Distributor uses a P.C., a modem, and ECM plug-in hardware to reprogram the DDEC system. The fee for these changes is minimal and can help increase residual value at time of trade-in.

This presentation is a brief overview of the Series 60 features and benefits. Detroit Diesel is proud of the Series 60 engine product line and its acceptance in the marketplace. The Series 60 engine is our commitment to your future, by providing the trucking industry with a durable and reliable engine with excellent fuel economy.

We are confident that once you try the Series 60 you will realize the importance of selecting the right product for your business future. The Series 60 engine is the product that will take you through the 90's and beyond. The Series 60, a commitment to the future.

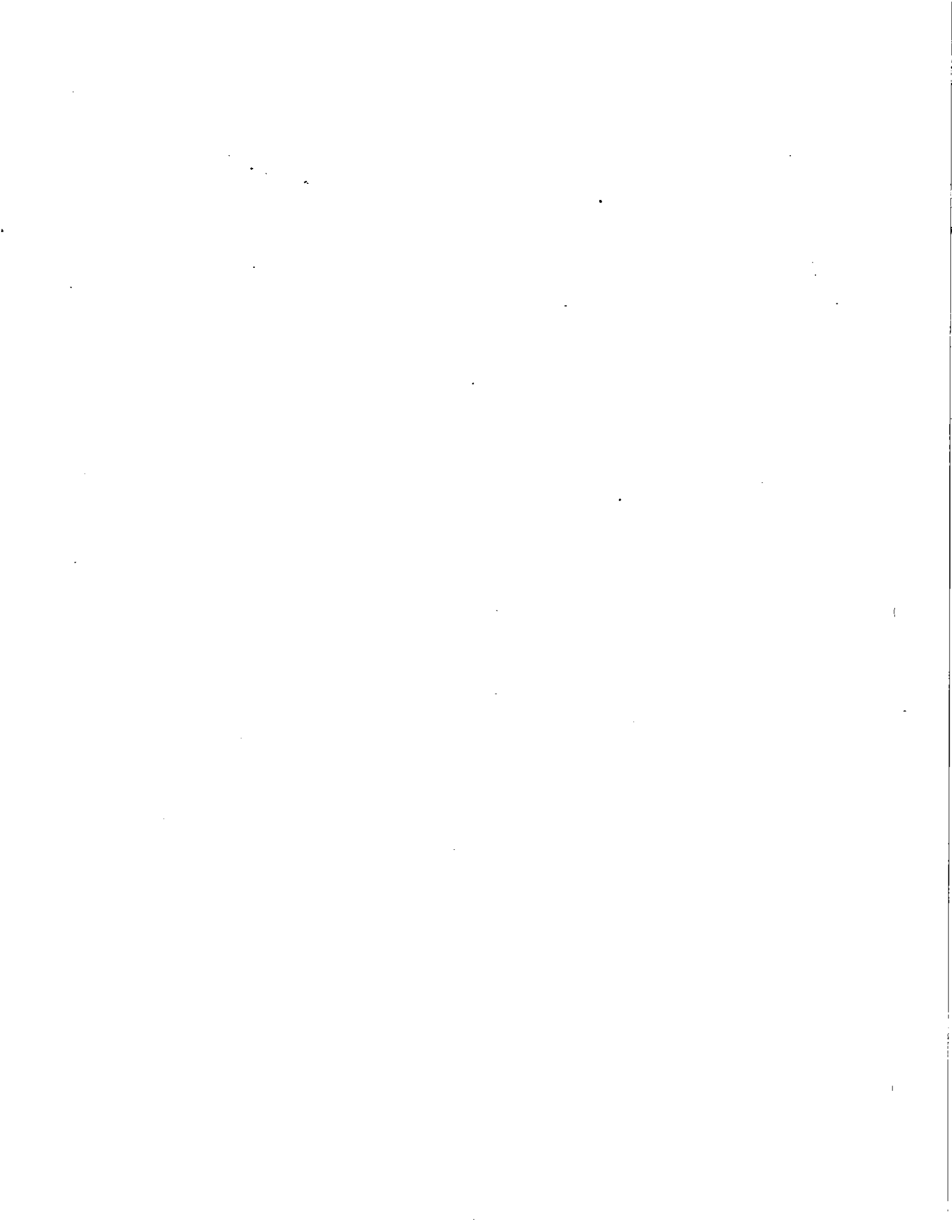



\$15.00

# Troubleshooting and Maintenance Manual



*Jacobs*®

J, Jacobs', Jake brake', and Auto-Lash' are registered trademarks of  
Jacobs Vehicle Equipment Company  
22 East Dudley Town Road  
Bloomfield, CT 06002  
Jake is a Marc. Reg. in Mexico

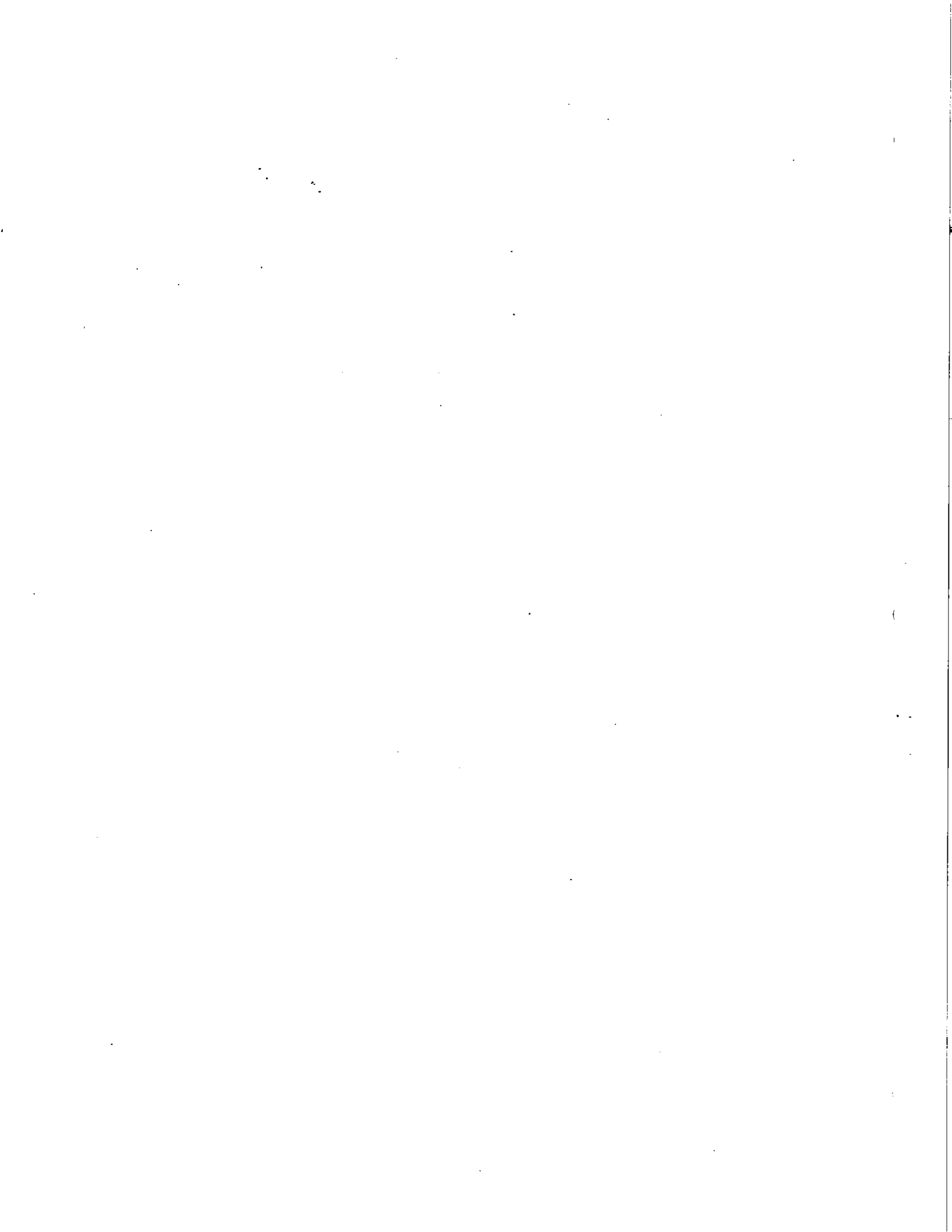

# Troubleshooting and Maintenance Manual

## Table of Contents

Introduction .....	i
Safety Precautions .....	i
Engine Brake Part Replacement .....	i
Automatic Transmissions .....	i
<b>Section 1 Troubleshooting</b>	
<b>1.1 Electrical System .....</b>	<b>1.1</b>
Electric and Electronic Controls .....	1.1.1
Required Tools .....	1.1.1
Preliminary Electrical Checks .....	1.1.1
Switch Adjustments .....	1.1.2
Solenoid Valve .....	1.1.5
Troubleshooting: CAT PEEC Controls .....	1.1.7
Troubleshooting: DDEC II Electronic Control Group .....	1.1.11
Troubleshooting: Low Engine Speed Retarder Cutoff .....	1.1.17
<b>1.2 Hydraulic/Mechanical .....</b>	<b>1.2</b>
Theory of Operation .....	1.2.1
Operational Sequence .....	1.2.1
Brake Housings and Rocker Groups Inspection .....	1.2.2
Engine Brake Housing Oil Pressure Check .....	1.2.2
Preliminary Checks .....	1.2.4
Control Valve Component Inspection .....	1.2.4
Engine Brake Housing Oil Pressure Requirements .....	1.2.5
<b>1.3 General Problem Analysis .....</b>	<b>1.3</b>
Tools and Parts Available .....	1.3.1
General Problem Analysis .....	1.3.2
<b>1.4 Engine Brakes for Cummins Engines .....</b>	<b>1.4</b>
Two-valve Design .....	1.4.1
Special Features .....	1.4.2
Single-valve Design .....	1.4.3
Special Features .....	1.4.4

## Section 1 Troubleshooting (continued)

<b>1.5 Engine Brakes for Caterpillar Engines .....</b>	<b>1.5</b>
Caterpillar 3406/B/C Engines .....	1.5.1
Special Features.....	1.5.2
Exhaust Rocker Adjusting Screw .....	1.5.2
Slave Piston Adjusting Screw .....	1.5.2
Model 349A Engine Brake .....	1.5.3
Theory of Operation .....	1.5.3
Exhaust Blowdown .....	1.5.4
Trigger Valve Adjustment .....	1.5.4
Models C317, C317A, 317B and 317C Engine Brakes .....	1.5.7
Power-Lash™ .....	1.5.8
Housing Assembly Differences .....	1.5.9
Model C336 and 336A Engine Brakes .....	1.5.11
Exhaust Valve Stem Caps .....	1.5.12
Slave Piston Clearance Settings .....	1.5.12
<b>1.6 Engine Brakes for Detroit Diesel Engines .....</b>	<b>1.6</b>
General Application Information .....	1.6.1
Adjustment of Engine Brake Slave Pistons .....	1.6.1
Special Features/Procedures .....	1.6.2
Exhaust Bridges .....	1.6.2
Fuel Pipes .....	1.6.2
Fast Idle Buffer Switch .....	1.6.4
Oil Connectors .....	1.6.4
Clevis for Injector Rocker Lever.....	1.6.5
Models 760/760A/765 Engine Brakes .....	1.6.7
Housing Mounting Bolts .....	1.6.7
Ball Check Valve Model (760) .....	1.6.8
<b>1.7 Engine Brakes for Mack Engines .....</b>	<b>1.7</b>
General Application Information .....	1.7.2
Special Features/Procedures .....	1.7.2
Valve Stem Caps .....	1.7.2
Slave Piston Adjusting Screw .....	1.7.2
Oil Supply Screw (675/675A) .....	1.7.3
Exhaust Valve Yoke .....	1.7.3

## Section 2 Preventative Maintenance

<b>Preventative Maintenance Introduction .....</b>	<b>2</b>
<b>2.1 Inspection Criteria .....</b>	<b>2.1</b>
Safety Valve Screw Assembly Inspection .....	2.1.1
Exhaust Crosshead/Bridge or Valve Stem Cap Inspection .....	2.1.1
Master Piston Inspection .....	2.1.2
Injector/Exhaust Rocker Arm Adjusting Screw Inspection .....	2.1.2
Slave Piston Inspection .....	2.1.3
Crosshead Screw and Pin Assembly Inspection .....	2.1.3
Slave Piston Adjusting Screws Inspection .....	2.1.4
Control Valve Inspection .....	2.1.4

## Introduction

Jacobs Engine Brakes are manufactured to the highest standards of quality. Care has been taken in every step of manufacture to produce a product capable of functioning reliably at normal and peak performance. This manual has been prepared to assist the operator and mechanic in correct maintenance and troubleshooting procedures that ensure satisfactory engine brake operation.

Troubleshooting, as discussed in Section 1, is a step-by-step procedure to determine the cause of malfunctions and problems interfering with satisfactory engine brake operation. Malfunctions and/or problems occurring in the Jake Brake can be classified as Electrical or Hydraulic/Mechanical in nature. To effectively troubleshoot the engine brake system, the mechanic must have a working knowledge of these two systems.

Section 1 describes the basic operation of engine brakes and components, and recommends procedures to follow when troubleshooting.

Proper maintenance, as discussed in Section 2, will assure maximum engine brake performance and a reliable service life.

## Safety Precautions

The following symbols in this manual signal potentially dangerous conditions to the mechanic or equipment. Read this manual carefully. Know when these conditions can exist. Then, take necessary steps to protect personnel as well as equipment.



This symbol warns of possible personal injury.



This symbol refers to possible equipment damage.

Do not work on this equipment when mentally or physically fatigued. Always wear eye protection.

Fuels, electrical equipment, exhaust gases and moving parts present potential hazards that could result in personal injury. Take care when installing an engine brake. Always use correct tools and proper procedures.

The Jake Brake is a vehicle slowing device, not a vehicle stopping device. It is not a substitute for the service braking system. The vehicle's service brakes must be used to bring the vehicle to a complete stop.

Jacobs Service Letters should be consulted for additional applications and updated information.

## Engine Brake Part Replacement

Each engine brake housing assembly has an identification tag showing model number and part number. A packaged housing assembly has a different part number than the housing assembly inside the package. When ordering a replacement housing assembly, the packaged housing assembly part number must be used.

The Installation Manual should be used in conjunction with the Jacobs Parts Manual when additional replacement part information is required. The Parts Manual can be obtained from your Jacobs distributor.

For more information on driving with the Jake Brake, read your Jacobs Driver Manual.

## Automatic Transmissions

For vehicles with automatic transmission, refer to Jacobs Service Letters or contact your nearest distributor.

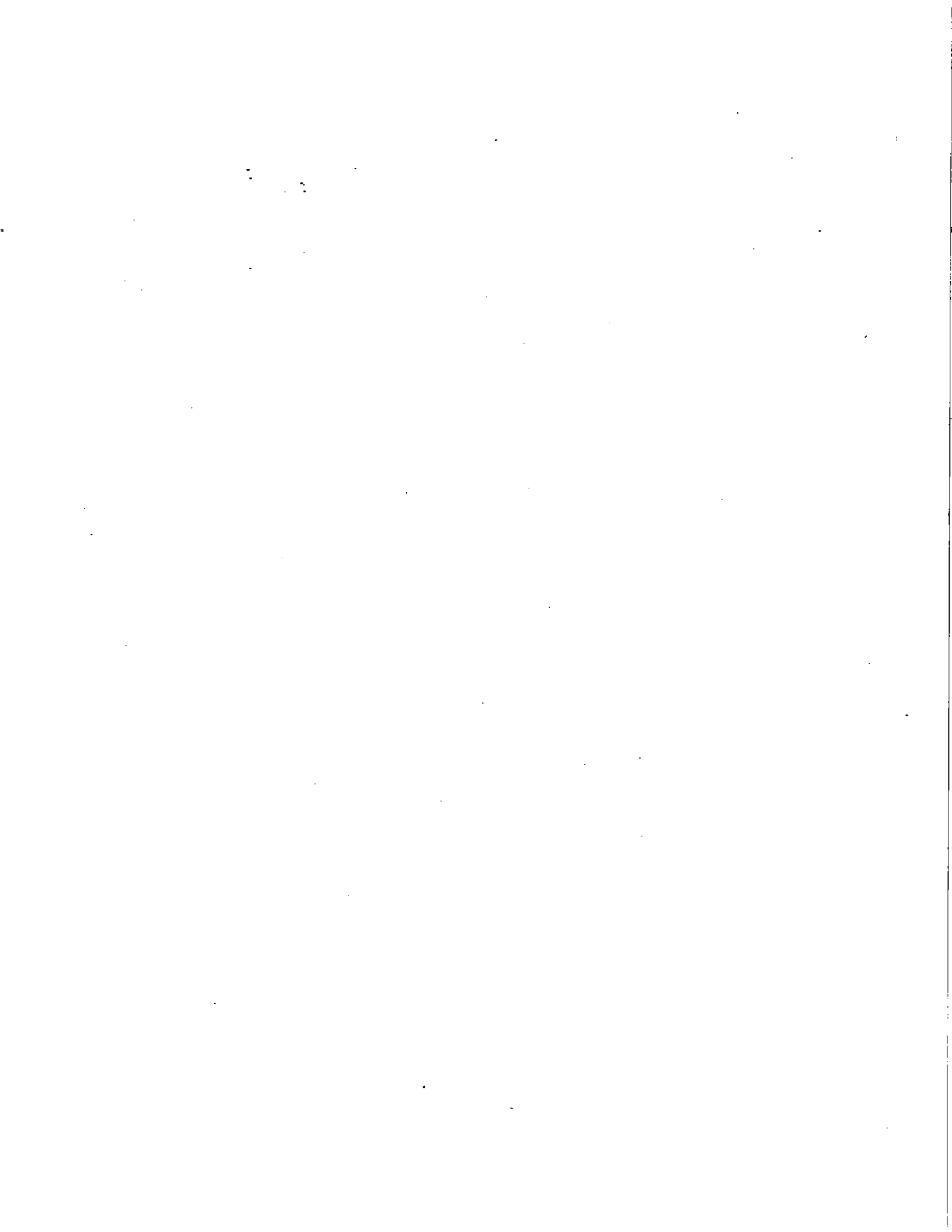

# 1.1 Electrical System

## Electric and Electronic Controls

Advancements in vehicle and engine controls have demanded changes to Jacobs Engine Brake control systems. New engine control systems include the following:

Caterpillar: PEEC	Cummins: CELECT
Detroit Diesel: DDEC	Mack: V-MAC

Section 1.1 Electrical System covers basic information and troubleshooting of electric and electronic control systems.

Electrical power to energize the Jake Brake should always come from a terminal on the vehicle ignition switch that is energized when the switch is turned "on". This circuit must be protected by a 10 amp fuse or circuit breaker. The circuit is then connected to the on/off switch, clutch switch, fuel pump (buffer) switch, and then to the solenoid valves.

Refer to the wiring diagram for specific engine brake models being worked on.

### NOTE

A diode is incorporated in the system at the fuel pump (buffer) switch. The diode prevents high voltage spikes that occur each time the solenoids are de-energized. This prevents internal damage to the switches.

## Required Tools

The following tools should be available to troubleshoot electrical problems:

1. Volt/OHM/AMP Meter (Digital Readout)
2. Continuity Tester
3. Test Light

## Preliminary Electrical Checks

1. Vehicle Electrical Power. Using a voltmeter, check to see that the supply voltage is at least 12 - 14 VDC or 24 - 28 VDC. Verify that wiring follows the correct Jacobs Engine Brake wiring schematic.

If the truck is factory pre-wired and the power source is from a breaker panel, make sure the circuit breaker is correctly reset. Make certain power is not drawn from a source with an additional ON - OFF switch or power draw for other components.

2. Jacobs' Switches. Using a voltmeter, check the dash switch, clutch switch and throttle switch for a voltage drop across each switch with the switch closed. Replace the switch if a voltage drop is 0.4 VDC or greater.

Inspect switches for correct adjustment. Check the throttle and clutch return springs for correct adjustment and operation.

3. Wiring. Check for short circuit in the wiring. Replace any broken, brittle, chafed, scorched or melted wires. It is recommended that all underhood or under-doghouse wiring be covered by Jacobs' Auto-Loom or similar good quality loom. Replace Jacobs in-line fuse (10 amps).

The following procedures are recommended:

Wire-end terminals should be securely attached to wires. If not, replace terminal. Wire size should be no smaller than 16 gauge.

Wire-end terminals should be attached tightly to space connectors. If not, remove and replace, or if necessary, re-crimp and reattach.

Harness wire or loom should be carefully routed and should not contact moving equipment such as throttle, clutch or transmission linkage.

Harness wire or loom should not contact high temperature engine components such as exhaust manifold or turbo housings.

Harness should be secured in place with tie-wraps at regular intervals.

## Clutch Switch

Adjust the switch by moving the switch along the mounting bracket. The actuator arm should be deflected 1.0 - 1.5 inches (25 - 38 mm), measured at the tip of the actuator, when the clutch pedal is in the up (clutch engaged) position.

Check installation by moving the clutch pedal. The switch should click from the open to closed position of the switch contacts in the free-play motion of the clutch pedal before actual clutch disengagement takes place.

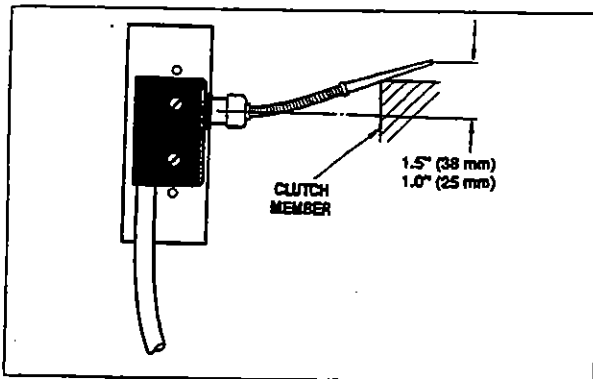

Fig. 1.1.1



Exceeding 1.5-inch deflection of the actuator arm may cause switch damage, resulting in engine brake malfunction.

## Fuel Pump Switch (Cummins PT Fuel Pump)

Move the throttle to the low idle position and insert a 0.05-inch (1.27 mm) feeler gauge between the switch plunger and actuating lever (Fig. 1.1.2). Push the switch lever against the switch plunger until the plunger bottoms. Tighten the cap screw to 7 lbft. (10 N•m).



After installing the actuating arm, check the fuel pump throttle shaft to be sure the throttle pedal will move the shaft to the full fuel position. Failure to do so may result in restricted engine control. If the restricted movement is found, correct the problem and readjust the actuating lever.

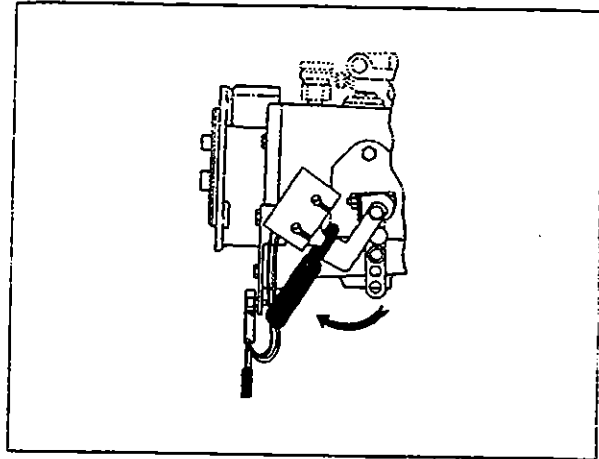

Fig. 1.1.2

## Diode Protection

Note:

Switch contacts are protected against arcing by a small diode connected between the load side switch terminal and ground. The engine brake must be connected to the load side terminal. If the vehicle has a positive ground electrical system, reverse the direction of the diode (Fig. 1.1.3).

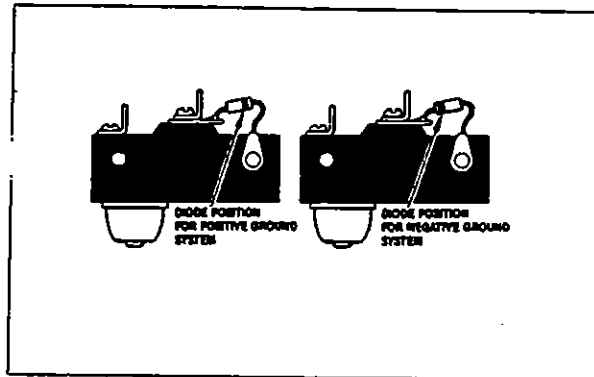

Fig. 1.1.3



## Buffer Switch Adjustment

### Buffer Switch - Detroit Diesel



Fig. 1.1.4

1. Start the engine and allow to warm up. Record the idle RPM and maximum no load RPM.
2. With the idle speed set, adjust the buffer switch as follows:
  - a. Turn the buffer switch in until it contacts the connecting link as lightly as possible and eliminates engine roll (Fig. 1.1.4).

#### NOTE:

Engine idle speed with the buffer switch must not increase more than 15 RPM from the reading recorded in Step 1.

- b. Hold switch in this position and tighten locknut.



Do not tighten locknut more than 60 lbin. (7 N·m). Switch failure will result from over-torquing.

- c. Check maximum no-load speed. If the increase is more than 25 RPM from the reading recorded in Step 1, back off buffer switch until increase is less than 25 RPM.
3. Shut down engine.

4. Early style buffer switches are polarity sensitive. Attach **NEGATIVE** lead (load side) to tin-plated terminal and the **POSITIVE** lead (power side) to the brass-colored terminal of the switch.
5. Current style buffer switches include a two-diode system for switch protection. The two-diode type switch is not polarity sensitive and electrical connections can be made to either terminal (see Fig. 1.1.5).

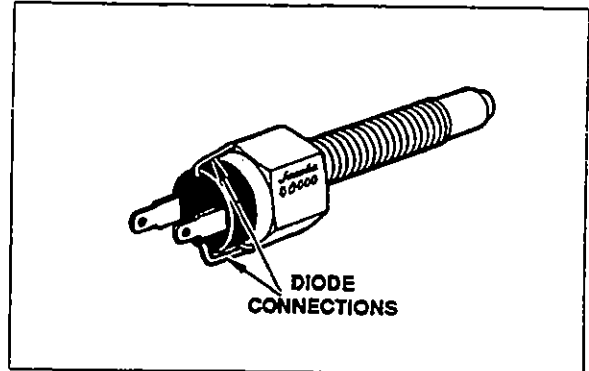

Fig. 1.1.5

## Fuel Pump Switch Adjustment - CAT

1. Start engine and check low idle RPM. Disconnect the throttle linkage and adjust the idle per Caterpillar specification by turning the switch clockwise to increase and counterclockwise to decrease engine RPM (Fig. 1.1.6).

### Fuel Pump Switch - Caterpillar 3406

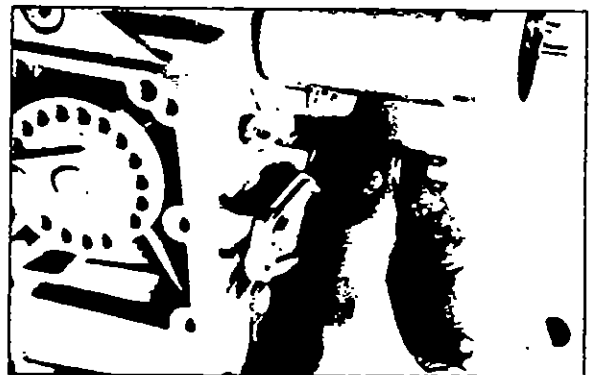

Fig. 1.1.6

- When proper RPM is set, advance the throttle lever to increase engine speed and then return to idle. Check to be sure the idle RPM setting did not change. Readjust if necessary.
- Hold the Jacobs switch and tighten locknut to 5 lbf. (7 N·m). Reconnect throttle linkage.

If the fuel pump switch has a letter "D" or lower suffix after the part number, this switch is polarity sensitive. Connect the white wire from the engine harness to the silver terminal. Connect the orange wire from the engine harness to the brass (load side) contact. This ensures diode protection of the switches.

If the fuel pump switch has a letter "E" or greater suffix after the part number, harness wires can be connected to either switch terminal. These switches have two diodes for protection and are not polarity sensitive.



Check to be sure that the governor operating lever moves freely from low idle to high idle position and releases without binding.

## Foot Switch

Optional Jacobs Foot Switch provides added driver convenience and control. Jacobs offers three different systems for engine brake control. Besides the standard semi-automatic system used with Caterpillar, Cummins and Mack engines, the customer now has the choice of two added options: fully automatic control with a "low speed" shut-off or fully manual control with a "foot switch".

The foot switch is installed on the cab floor within easy reach of the operator's left foot. After installation, light foot pressure on the top plate is all that is needed to operate the Jake Brake. The throttle switch, or buffer switch, remains in the system to ensure that fueling and engine braking do not occur at the same time.

Foot Switch Diagram

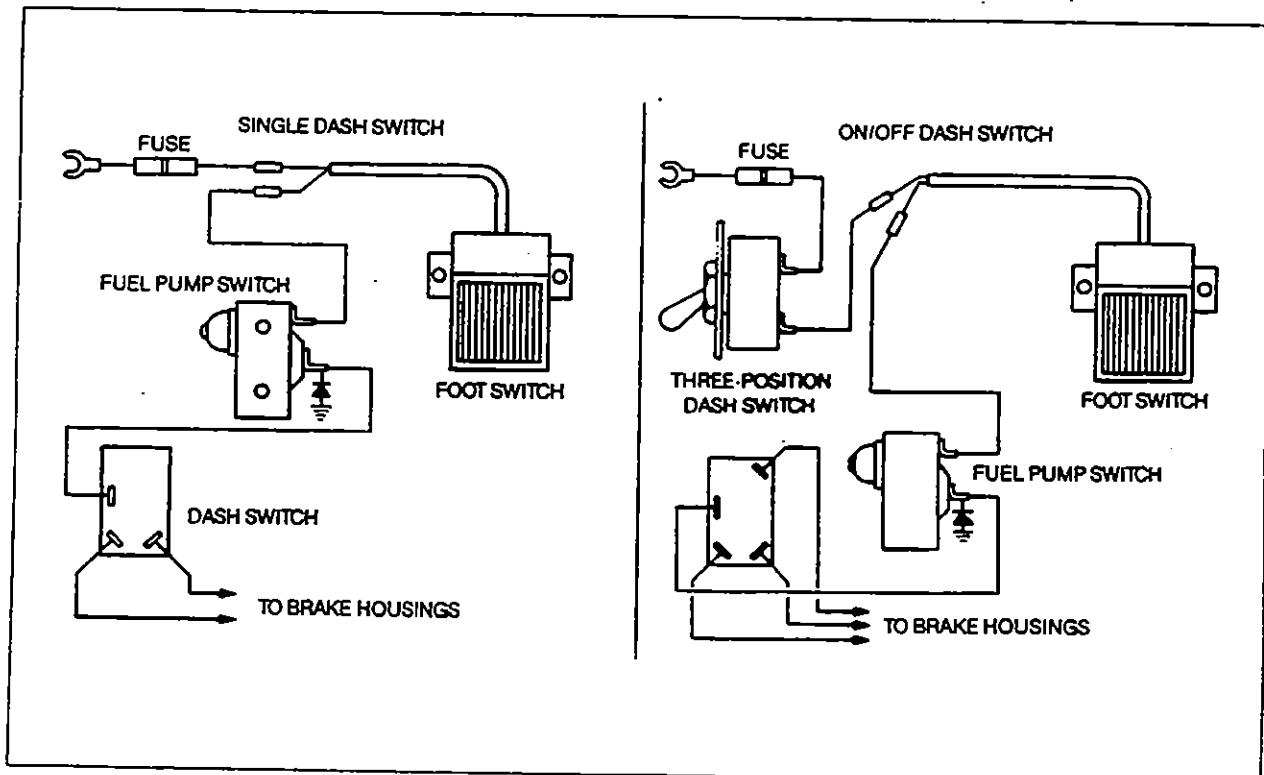

Fig. 1.1.7

## Solenoid Valve

The Solenoid Valve cannot be overhauled or repaired in the field. If any problem other than seal ring-related exists, the Solenoid Valve must be replaced.

### Operation Check

The best way to examine a solenoid valve coil for correct operation is with a volt/amp/ohm meter and then compare the readings for each solenoid with the proper specifications. If the proper meters are not available, a secondary check of proper solenoid valve operation can be made as follows:



Do not touch the electrical connection when a solenoid is energized. Electrical shock could result.

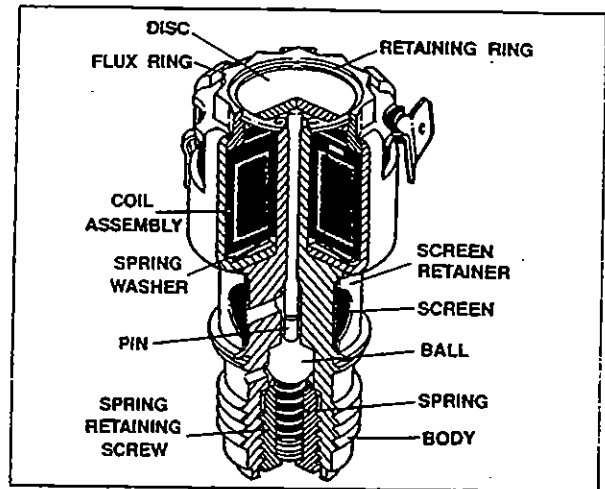

Fig. 1.1.8

1. Apply a 12-volt source to the solenoid electrical terminal.
2. When electrical power is supplied, make sure each solenoid valve cap depresses. If the cap does not depress, replace the solenoid.

P/N	VOLTAGE	RESISTANCE (OHMS)		CURRENT DRAW (AMPS)		PULL IN VOLTAGE (MINIMUM)	
		COLD	HOT	COLD	HOT	COLD	HOT
016440	12 VDC	9.75 to 10.75	11.8 to 14.3	1.12 to 1.23	0.84 to 1.02	7.5	8.5
016441	24 VDC S/L	31.5 to 38.5	38.2 to 50.0	0.62 to 0.69	0.47 to 0.55	17.0	21
016442	24 VDC D/L	31.5 to 38.5	38.2 to 50.0	0.69 to 0.62	0.47 to 0.55	17.0	21
018674	12 VDC	9.5 to 10.5	11.5 to 14.0	1.15 to 1.25	0.86 to 1.04	9.5	11.9 to 12.7
013472	24 VDC	34.9 to 38.7	43.3 to 51.3	0.62 to 0.69	0.47 to 0.55	18.0	22 to 24
003784, 004205, 003433, 002689	12 VDC	19.8 to 22.0	24.0 to 29.5	0.54 to 0.61	0.4 to 0.5	9.0	9.8 to 12.1
003784, 004205, 003433, 002689	24 VDC	19.8 to 22.0	24.0 to 29.5	1.08 to 1.22	0.8 to 1.0	9.0	9.8 to 12.1

Fig. 1.1.9

## Jacobs Model 346 B/C/D with Caterpillar PEEC\* Controls

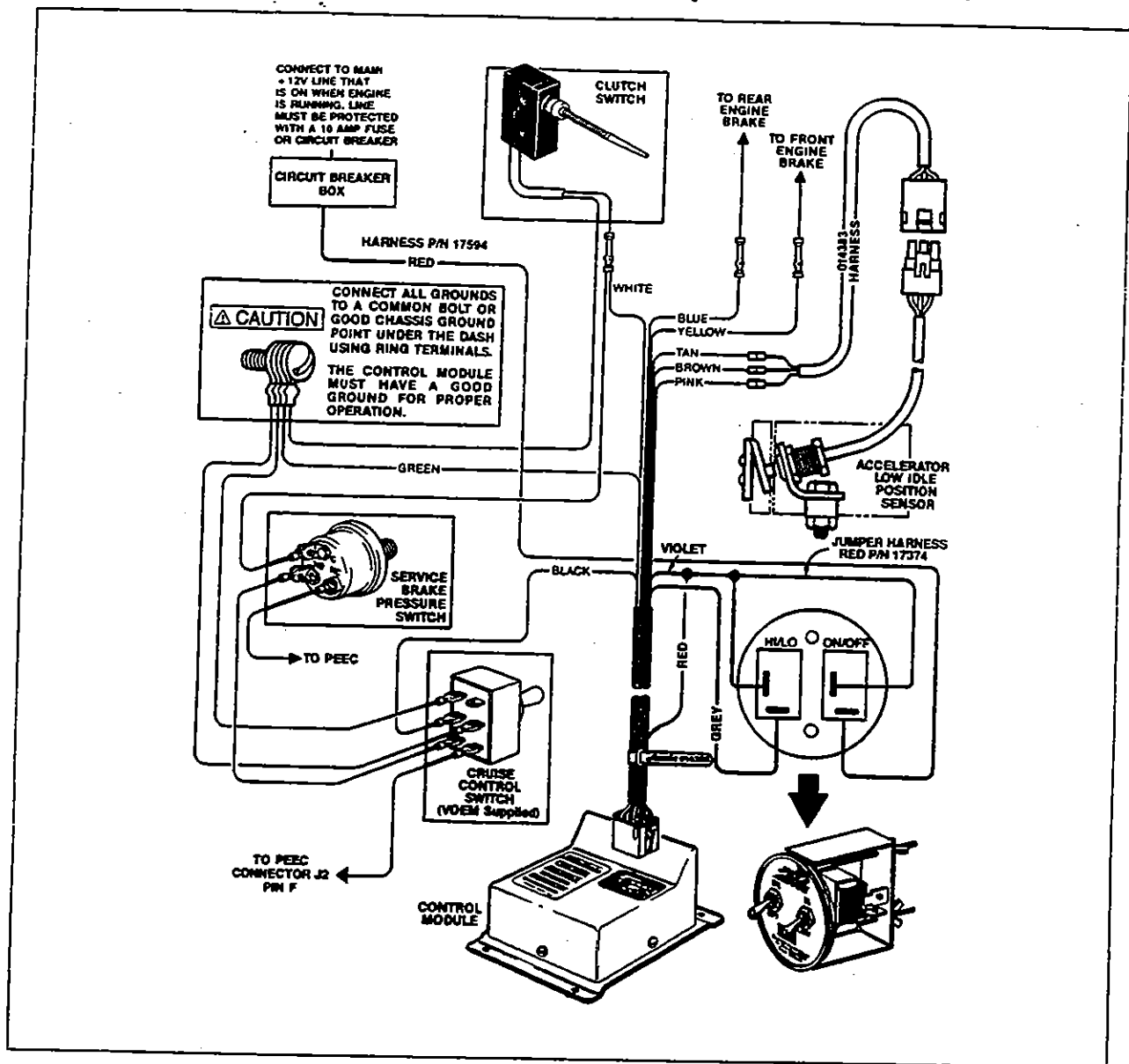

Fig. 1.1.10

\* Information on Caterpillar electronics (PEEC III) applications is not covered here and will be covered in separate documents.

Cat & Caterpillar are trademarks of Caterpillar Inc.

# Troubleshooting: CAT PEEC Controls

## Problem: Engine Brake is Inoperable

**Probable Cause:** No electrical power.

**Correction:** Connect VOM positive (+) probe to common (lower) terminal of on/off switch and negative (-) probe to ground (Fig. 1.1.11). With ignition switch on, VOM should read +12 volts. If not, check circuit breaker or fuse and wiring to switch and repair/replace as needed.

**Probable Cause:** Dash switch(es) inoperative.

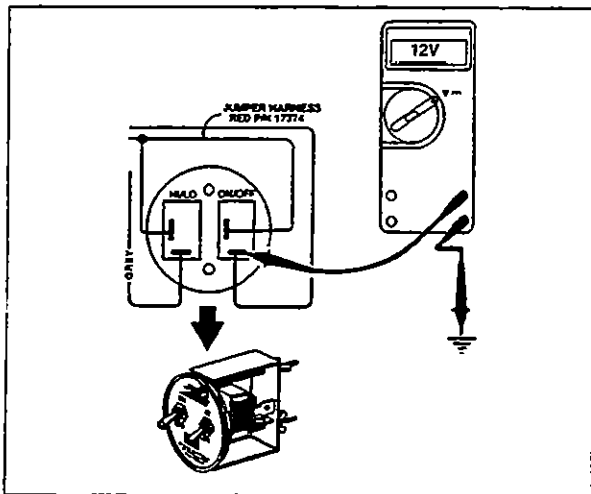

Fig. 1.1.11

### Correction:

- A. Connect positive (+) probe of VOM to center terminal of on/off switch and negative (-) probe to ground. With system energized and switch off, reading should be 0 volts. With switch on, reading should be 12 volts. If these readings are not obtained, replace on/off switch.
- B. Connect positive (+) probe to center terminal of hi/lo switch and negative (-) probe to ground. With on/off switch on and hi/lo switch in lo position, reading should be 12 volts. If not, check switch jumper wire and connections and repair/replace as needed.

- C. Connect positive (+) lead to lower terminal of hi/lo switch and negative (-) probe to ground. With hi/lo switch in lo position and on/off switch on, reading should be 9 volts. With hi/lo switch in hi position, reading should be 12 volts. If these readings are not obtained, replace hi/lo switch.

**Probable Cause:** Control module defective.

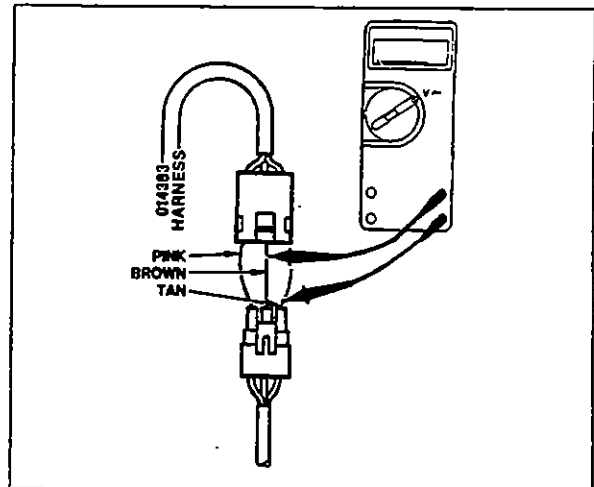

Fig. 1.1.12

**Correction:** De-energize the system and disconnect the harness, P/N 014383, from the ALIPS harness. Using the three clip leads, reconnect the brown, tan and pink wires. Connect the positive (+) probe to the tan wire and the negative (-) probe to the brown wire (Fig. 1.1.12). With the system energized and clutch engaged (pedal up), reading should be 5 volts. If not, replace the control module.

**Probable Cause: ALIPS sensor inoperative.**

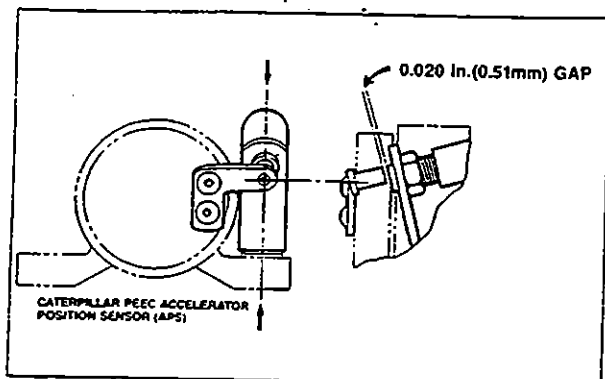

Fig. 1.1.13

**Correction:** If the previous reading was 5 volts, connect the positive (+) probe to the pink wire and the negative (-) probe to the brown wire. With the accelerator in the low idle position, the VOM should read 0 volts. If the reading is not 0 volts, the clearance between the magnet and sensor may be too large or the magnet may not be in line with the sensor. If necessary, realign the magnet and sensor and readjust the clearance to 0.02 inches (0.51 mm) (Fig. 1.1.13). If the volt meter still does not read 0 volts, replace the sensor assembly.

With the accelerator depressed, the reading should be 5 volts. If not, replace the ALIPS sensor assembly.

If the ALIPS sensor assembly functions properly, remove the clip leads and reconnect the harness.

**Probable Cause: Clutch switch inoperative.**

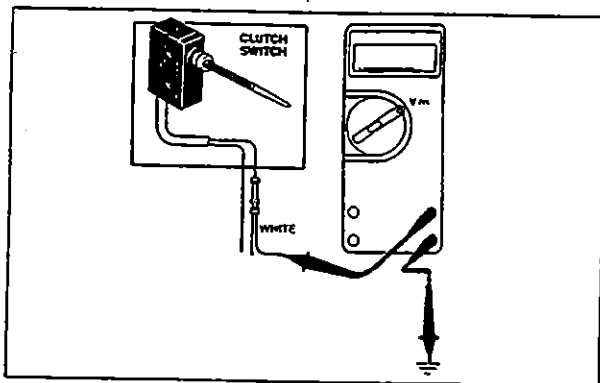

Fig. 1.1.14

**Correction:** Connect the negative (-) probe to the common ground point and the positive (+) probe to the white lead in the main harness (Fig. 1.1.14). Energize the system. With the clutch engaged (pedal up), VOM should cause a reading of 5 volts. If these readings are not obtained, check adjustment of clutch switch. Switch should actuate in the top travel portion of the pedal. Readjust if necessary.

If these checks are not OK, disconnect the wires at the clutch switch. Check continuity between the switch terminals. There should be 0 Ohms resistance with the switch activated (contacts closed) and infinite resistance with the switch relaxed (contacts open). If these conditions do not exist, replace switch.

**Probable Cause: Service brake pressure switch inoperative.**

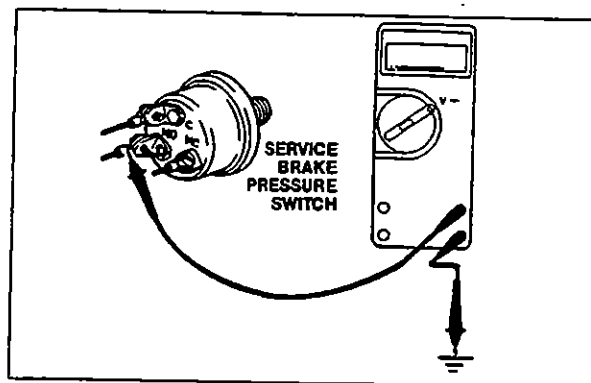

Fig. 1.1.15

**Correction:** Connect the positive (+) probe of the VOM to the normally open (NO) contact of the brake pressure switch and the negative (-) probe to ground. With the system activated, sufficient air pressure to activate the brake pressure switch, cruise control switch on, and clutch pedal up, the volt meter should read 5 volts (Fig. 1.1.15). With the service brake pedal depressed, the volt meter should read 0 volts. If these readings are not obtained, replace the service brake pressure switch.

**Probable Cause: Control module inoperative.**

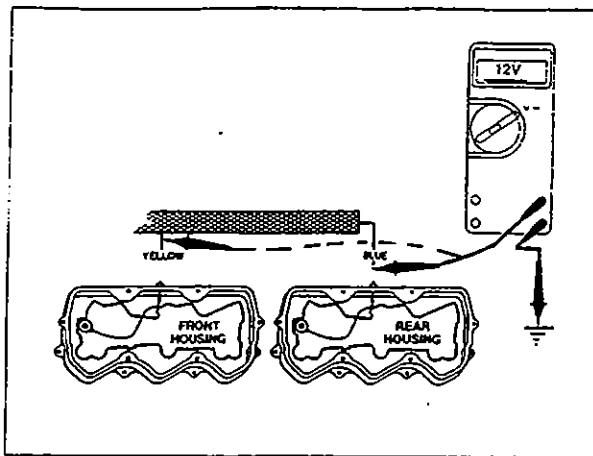

Fig. 1.1.16

**Correction:** If all of the above procedures do not locate the problem, disconnect the wire harness at the engine brake spacers. Set the selector switch in high, accelerator in low idle, cruise control switch off and clutch switch activated, both blue and yellow wires should read 12 volts (Fig. 1.1.16). Depressing the clutch should cause the voltage at each wire to drop to 0 volts. If these readings do not occur, replace the control module.

**Probable Cause: Solenoid Valve**

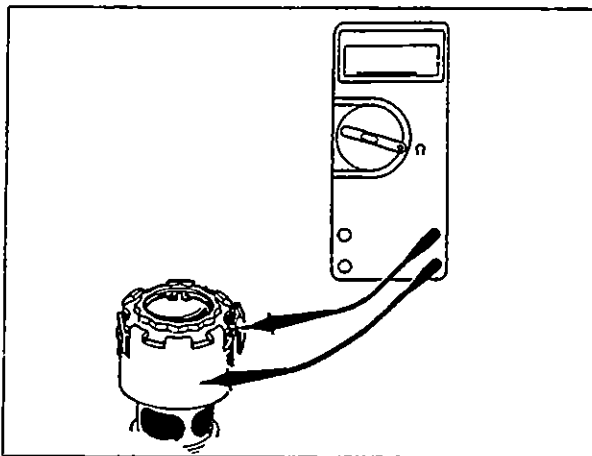

Fig. 1.1.17

**Correction:** With the blue and yellow wires disconnected at the engine brake spacers, connect one probe of the VOM to the solenoid terminal and the other probe to ground at the solenoid body (Fig. 1.1.17).

Reading should be 9.75 to 10.75 Ohms for current solenoid valves, P/N 016640. For early style solenoid valves, P/N 004205, the resistance should be 19.8 to 22 Ohms. If not, replace the solenoid valve.

If solenoid resistance is OK, check continuity of solenoid lead wires. No reading from solenoid to connection at spacer indicates an open circuit and wire must be replaced.

Model 760/760A/765 DDEC Series II Wiring Diagram (3 Mode)

MODEL 760, 760A & 765 DDEC SERIES II  
WIRING DIAGRAM (3 MODE)

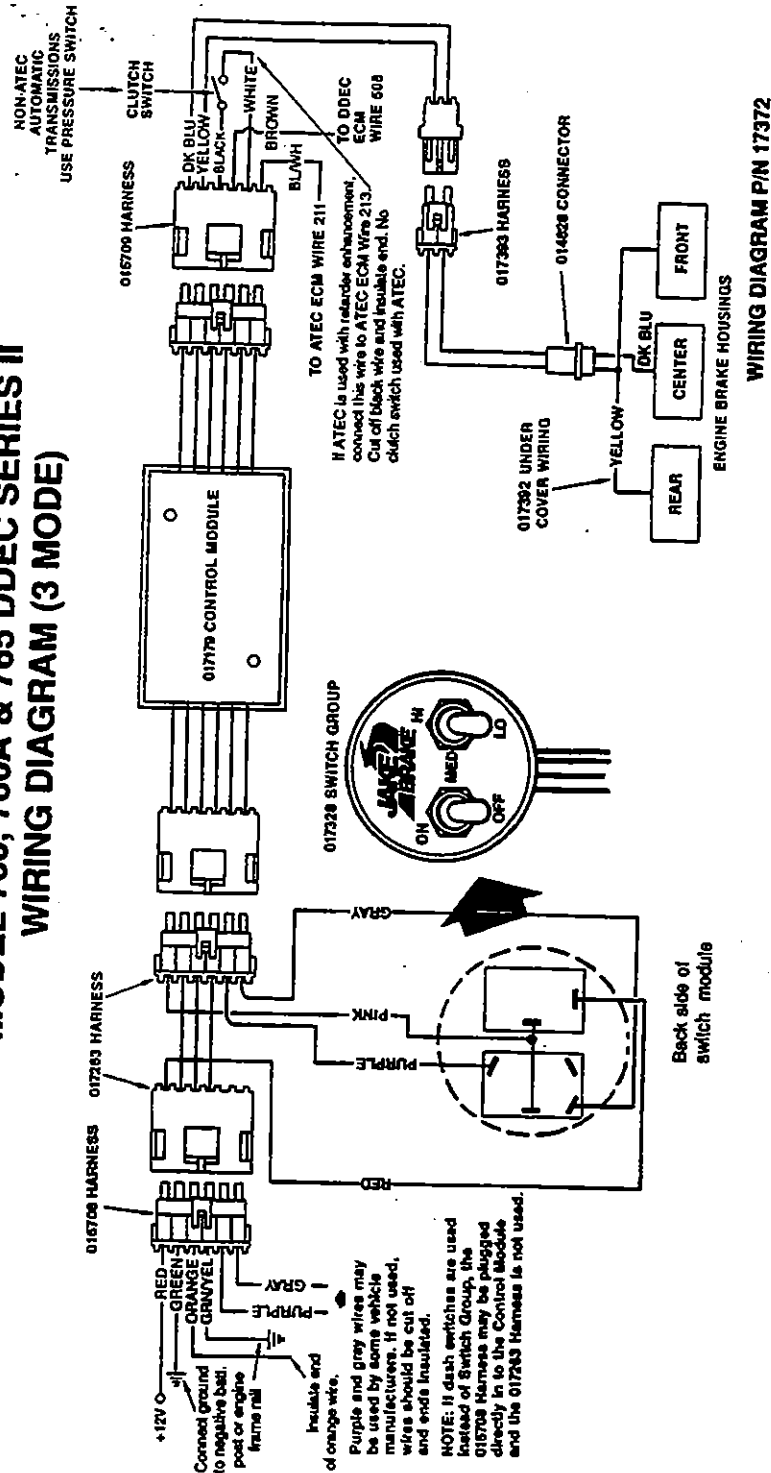

Fig. 1.1.18



## DDEC II Electronic Control Group Troubleshooting for Models 760/ 760A/765 and 71/92A Engine Brakes

The Jacobs Electronic Control Module, P/N 017179, is a sealed electronic device and is not field serviceable. The Control Module can be operated using the standard dash toggle switches or the Jacobs Dash Switch Module, P/N 017328 or 017346. To test if this device requires replacement, follow the step-by-step procedures within the troubleshooting guide.

### Equipment Required for Testing:

Voltmeter with 20,000 Ohm/volt input impedance, minimum. Keep the voltmeter on the 20 VDC/div scale for the 12-volt control and 200 VDC/div scale for the 24-volt control for all test measurements.

#### NOTE:

This control can be used for 12- or 24-volt operations. Use +12/24 volts when referring to the (+) battery voltage. This guide will make reference to a 12-volt operation. Actual battery voltage may vary up to 2 volts.

If measuring the voltage at the solenoid valves, make sure that all wiring harnesses are connected. If the voltage at the output of the control is measured without the solenoid valves connected, both the BLUE and YELLOW wires will measure approximately +1 volt. These are internal voltages established by the control module when the output wires are disconnected.

## Operation Function

- The in-line switch module (if used) is connected to the power input side of the control. This is the harness with the RED and GREEN wires, P/N 015708.
- The ON/OFF power switch connects the RED wire to the +12 volt vehicle electrical system providing power to the control module.
- The PURPLE and GRAY inputs select which one of the DK BLUE or YELLOW outputs will be active. The (AUX LO) GRN/YEL, (AUX HI) ORANGE, (#508) BROWN, and (CLUTCH SWITCH) BLACK and WHITE inputs control when the DK BLUE and YELLOW will be active. To allow the outputs to be active, the following must be true:
  1. The clutch switch closed connecting the BLACK and WHITE wires together.
  2. The (AUX LO) GRN/YEL wire connected to ground (0 VDC).
  3. The (#508) BROWN wire switches to ground (0 VDC).The (AUX HI) ORANGE wire should be insulated.

Before active troubleshooting is begun, check the integrity of all wiring and harness connections to verify that connections are tight and that wires are not pinched or have scraped insulation.

Model 71/92A DDEC Series II Control Group Wiring Diagram (2 Mode)

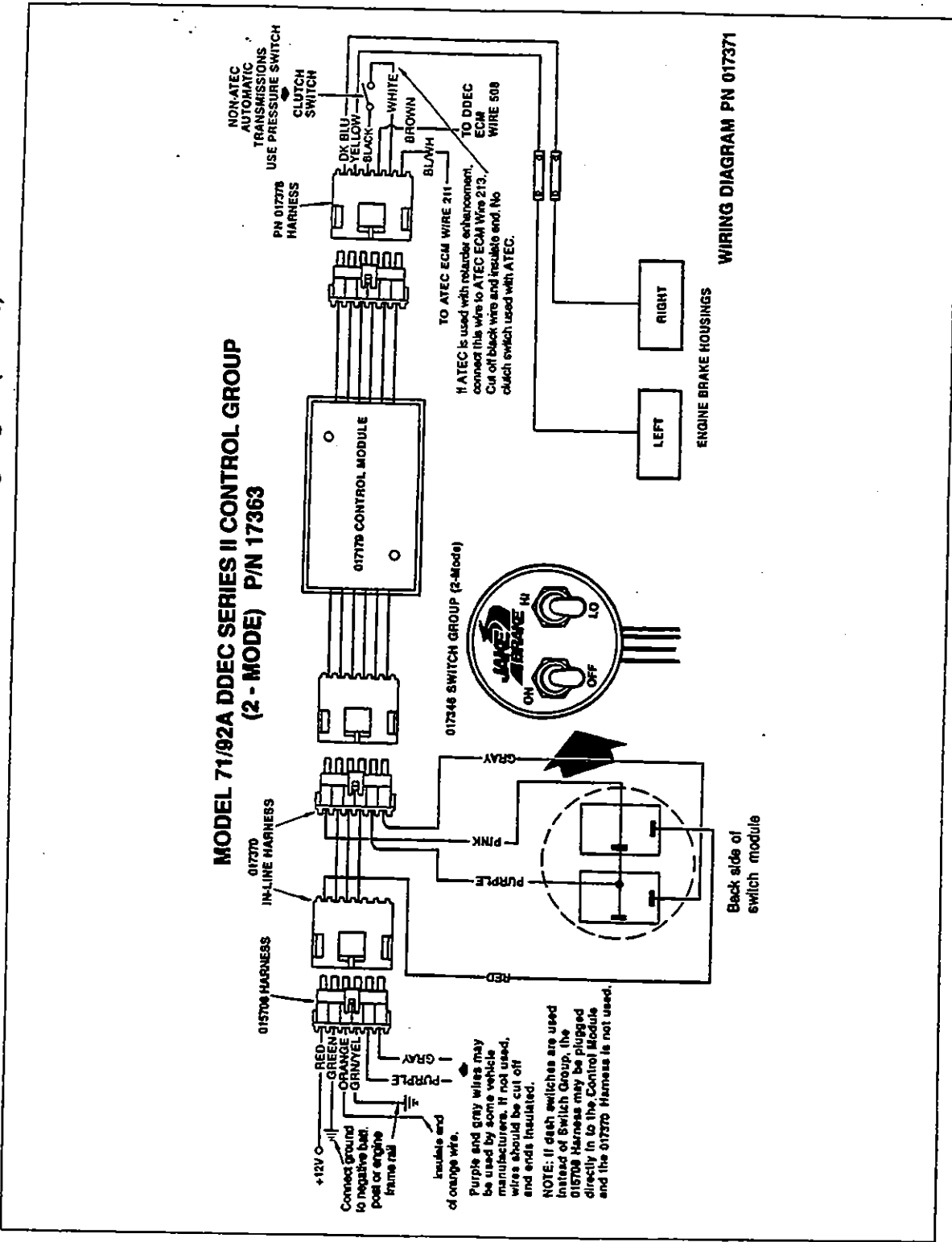

Fig. 1.1.19

# Troubleshooting: DDEC Controls

**Problem: Engine Brake will not activate**

**Probable Cause: Check supply voltage**

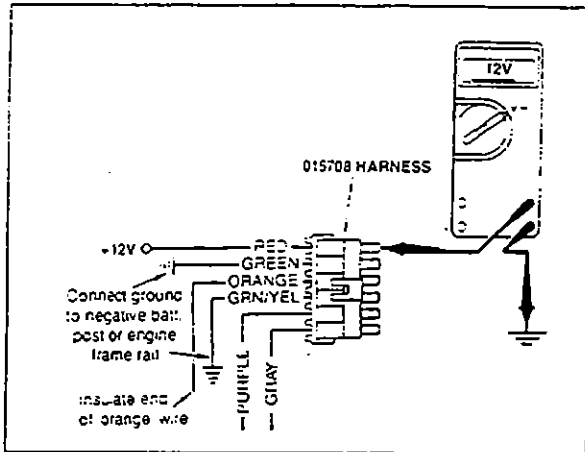

Fig. 1.1.20

**Correction:** With the ignition switch on, disconnect the P/N 015708 harness from the control module connector. Measure the voltage at the RED wire. Place the positive probe (+) of the voltmeter on the terminal of the RED wire and the negative probe (-) to ground. The voltmeter should read +12 VDC (Fig. 1.1.20). If this condition is not present, check that system is energized and check power supply.

**Probable Cause: Check switches and connections**

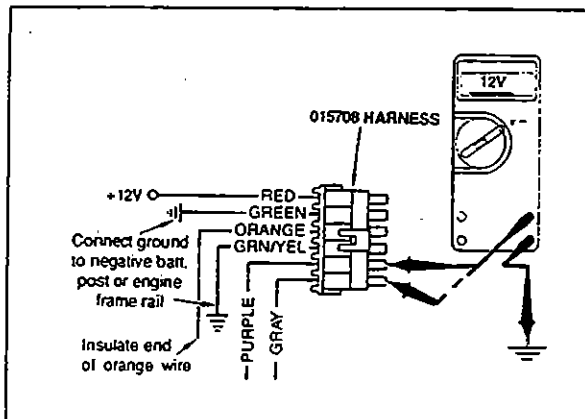

Fig. 1.1.21

**Correction:**

**Optional Selector Switch:** Disconnect P/N 015708 harness from control module. Measure voltage at both PURPLE and GRAY wires. With selector switch in HI position, both wires should read +12 VDC (Fig. 1.1.21). If this condition is not present, check power supply, connections and switches. Repair or replace as required.

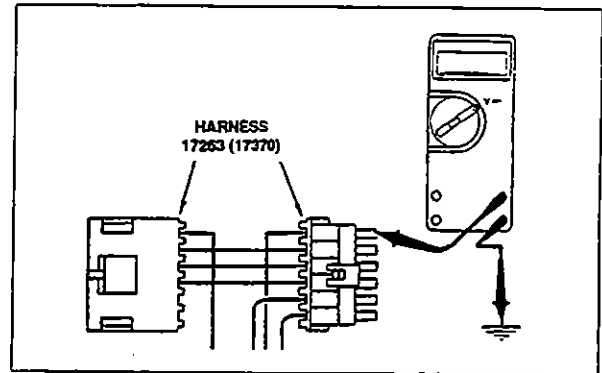

Fig. 1.1.22

**Jacobs Switch Group:** Disconnect P/N 017263 (017370) harness from Jacobs control module. Measure the voltage at the RED wire. The voltmeter should read +12 VDC when the main power supply is ON and 0 VDC with main power supply OFF (Fig. 1.1.22). If these conditions are not present, check power supply and connections.

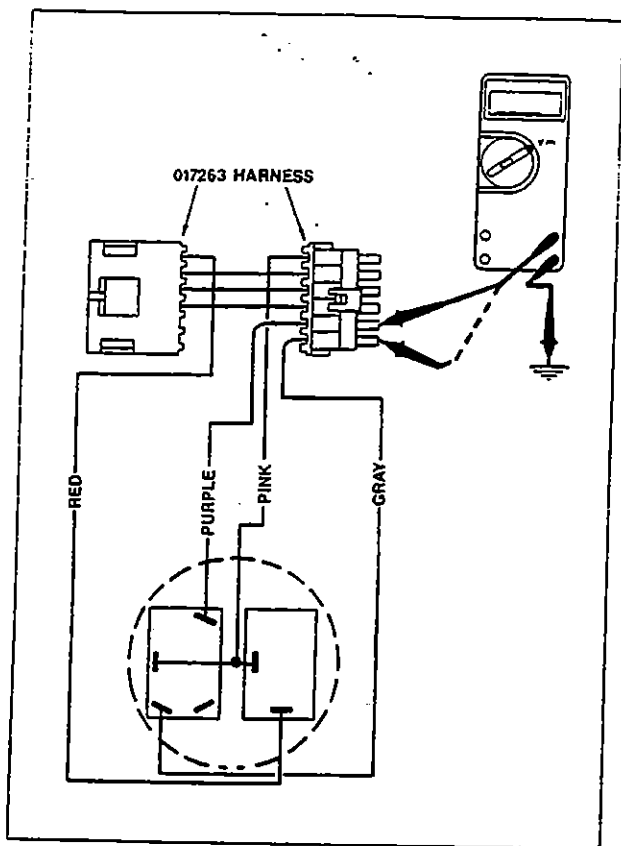

Fig. 1.1.23

(Fig. 1.1.23) With main power supply ON and selector switch in LO, the PURPLE wire should read +12 VDC and GRAY wire 0 VDC. With selector switch in MED position, GRAY wire should measure +12 VDC; PURPLE wire 0 VDC. With selector in HI position, both PURPLE and GRAY wires should measure +12 VDC. If these conditions are not present, check connections, check wiring schematic for proper position of wires to switch and/or replace switch.

Probable Cause: Check clutch switch.

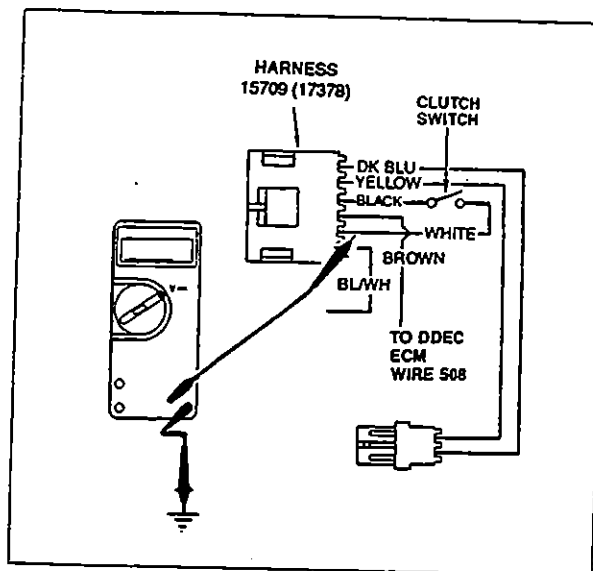

Fig. 1.1.24

**Correction:** With the P/N 015709 (017378) harness connected to the control module, measure the voltage at the terminal of the WHITE wire. With the clutch engaged (pedal not depressed), a reading of 0 VDC should be measured. With the clutch disengaged (pedal depressed) a reading of +5 VDC +/- 0.5 VDC should be measured (Fig. 1.1.24). If this condition does not exist, check continuity of clutch switch and BLACK and WHITE wires.

**Probable Cause:** Check engine brake enable signal.

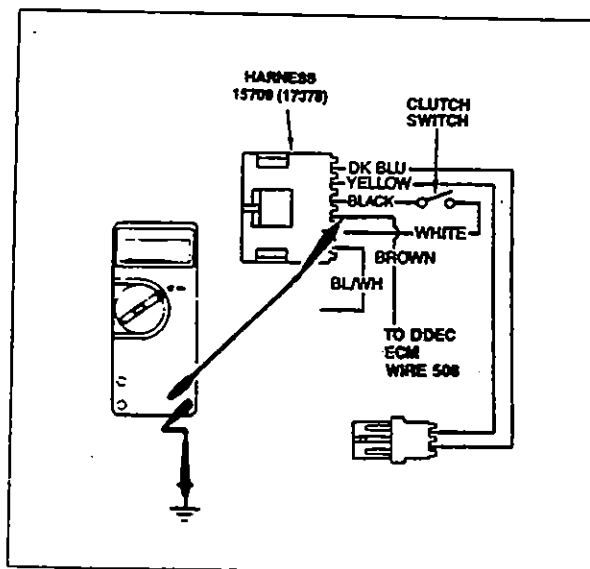

Fig. 1.1.25

**Correction:** Disconnect 015709 (017378) harness from 017179 module. Start the engine. Turn the engine brake switch OFF. Place the positive probe of the voltmeter at the terminal of the BROWN wire and the negative probe on ground (Fig. 1.1.25). Increase engine RPM to rated engine speed. The voltmeter should measure +12 VDC. Release throttle; voltage should drop to 0 VDC. When the engine reaches idle, the voltage should again read +12 VDC. If the voltage does not change, check connections and wiring. If problem continues, have the engine ECM checked.

**Probable Cause:** Check output.

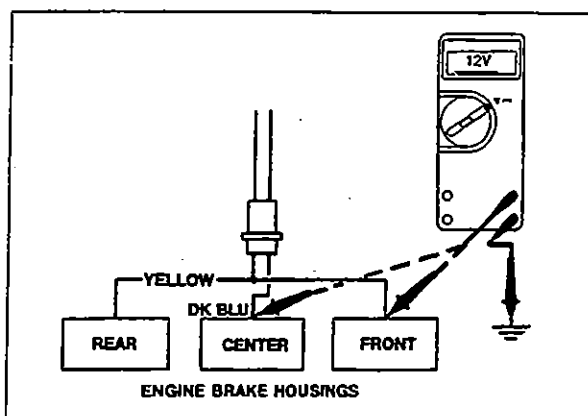

Fig. 1.1.26

**Correction:** Inspect DK BLUE and YELLOW wires leading to solenoid valve connectors. Check for loose contacts, pinched wires or scraped insulation. Start the engine, turn the engine brake switch ON and select HI. Advance the throttle to rated speed and then release the throttle. Voltage at both YELLOW and DK BLUE wires should measure +12 VDC (Fig. 1.1.26).

**NOTE:**

When measuring voltage, check that all harness connections are tight. If the voltage is measured with the harness from the solenoid loose or disconnected, both the DK BLUE and YELLOW wires will measure approximately +1 VDC. This is an internal voltage established by the control module for reference.

**Probable Cause:** Check Jacobs control module.

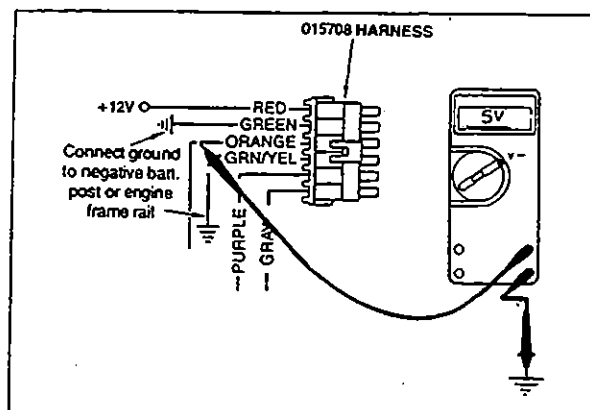

Fig. 1.1.27

**Correction:** Measure the voltage at the ORANGE wire of the control module. With system power ON, the voltage should measure +5 VDC +/- 0.5 VDC (Fig. 1.1.27). If this condition is not present, replace module.

**Problem:** Engine Brake performance erratic/intermittent

**Probable Cause:** Check ground connection.

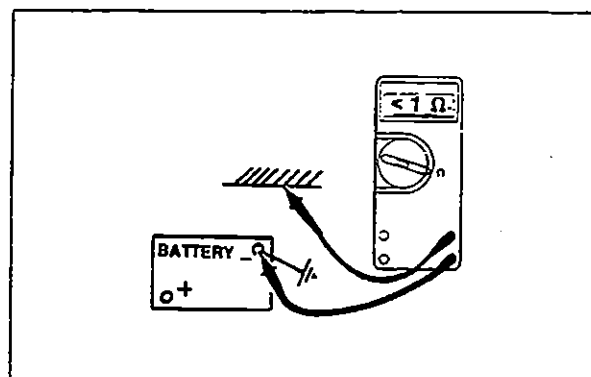

Fig. 1.1.28

**Correction:** The resistance between the engine block and the negative terminal of the battery must be less than 1 ohm (Fig. 1.1.28). The resistance between the GREEN wire of the engine brake control module and the negative terminal of the battery must be less than 5 ohms for proper module operation (Fig. 1.1.29).

**If vehicle is not equipped with ABS system:**

The GREEN/YELLOW wire must be grounded, preferably to the same point as the GREEN wire. These wires should be isolated from other system ground wires. The ORANGE wire must not be grounded and must be insulated.

**Probable Cause: Check undercover wiring.**

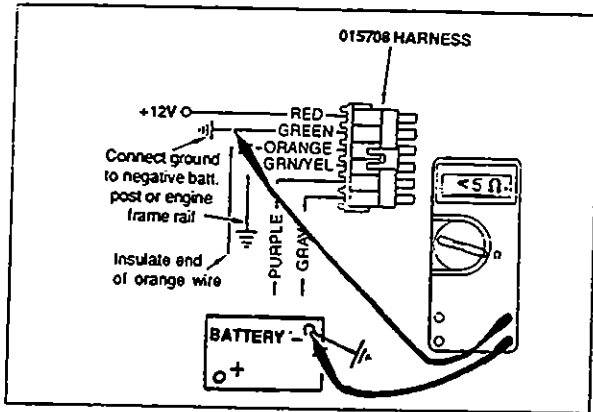

Fig. 1.1.29

**Correction:** Make sure solenoid wires are securely attached to the solenoid valves.

**Probable Cause:** Check for solenoid failure.

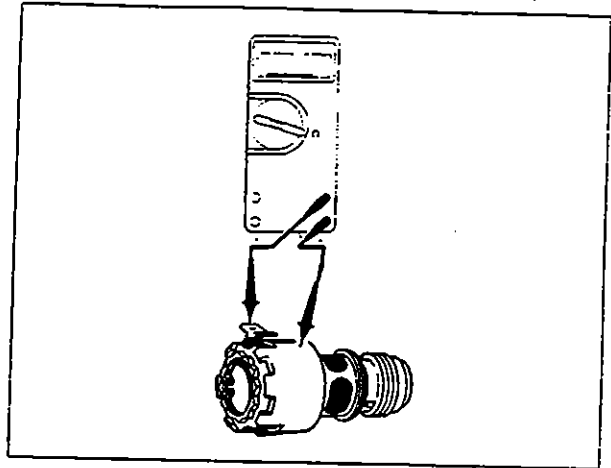

Fig. 1.1.30

**Correction:** Measure resistance of each solenoid valve (Fig. 1.1.30). Solenoid valves not within correct values must be replaced.

**NOTE:**

Resistance may increase significantly when solenoid valves are above 100 degrees F. See Fig. 1.1.9, page 1.1.5, for electrical requirements.

**Probable Cause:** Check Allison ATEC automatic transmissions.

**Correction:** Check that the BLUE/WHITE wire from the control module is connected to the ATEC ECM wire #211. The WHITE wire from the control module is connected to ATEC ECM wire #213. The BLACK wire from the control module must be insulated.

# Low Engine Speed Retarder Cutoff

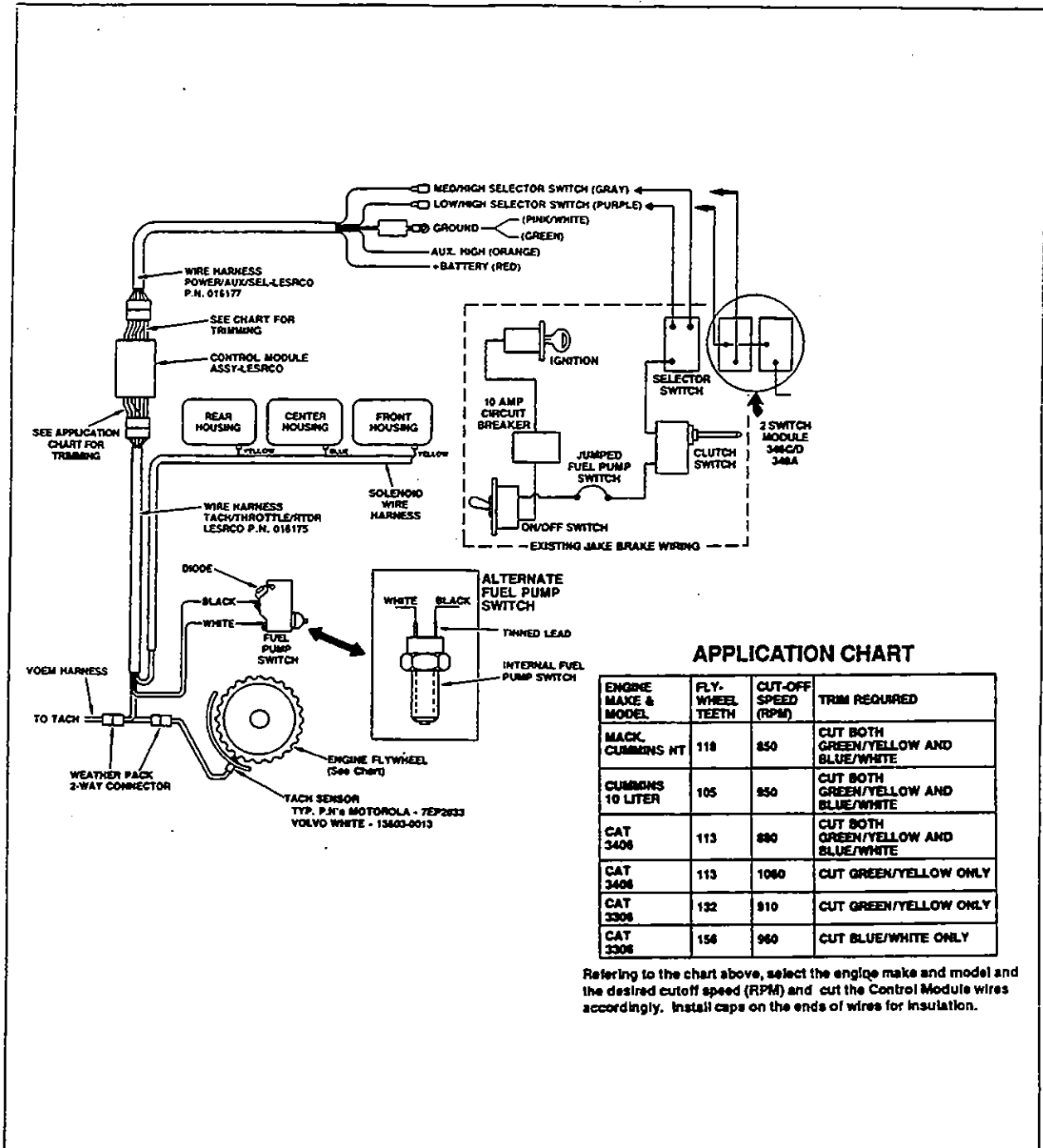

## APPLICATION CHART

ENGINE MAKE & MODEL	FLY-WHEEL TEETH	CUT-OFF SPEED (RPM)	TRIM REQUIRED
MAK, CUMMINS NT	118	850	CUT BOTH GREEN/YELLOW AND BLUE/WHITE
CUMMINS 10 LITER	105	950	CUT BOTH GREEN/YELLOW AND BLUE/WHITE
CAT 3406	113	880	CUT BOTH GREEN/YELLOW AND BLUE/WHITE
CAT 3406	113	1060	CUT GREEN/YELLOW ONLY
CAT 3306	132	910	CUT GREEN/YELLOW ONLY
CAT 3306	156	960	CUT BLUE/WHITE ONLY

Referring to the chart above, select the engine make and model and the desired cutoff speed (RPM) and cut the Control Module wires accordingly. Install caps on the ends of wires for insulation.

Fig. 1.1.31

# Troubleshooting Instructions

## Low Engine Speed Retarder Cut-off

**Problem:** Engine Brake will not operate.

**Probable Cause:** Power supply wire (red) disconnected, not energized.

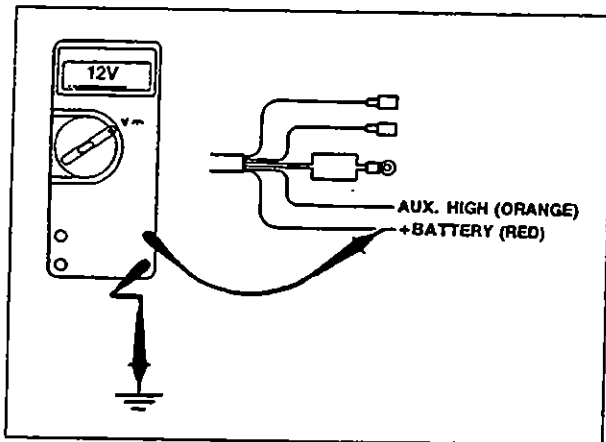

Fig. 1.1.32

**Correction:** Check that the connector between the vehicle power supply and the red line to the Jacobs control module is tight and free of any corrosion or oil. With the vehicle ignition turned on, +12 VDC must be measured at the red wire (Fig. 1.1.32). If not, continue with checks.

**Probable Cause:** Blown fuse or circuit breaker.

**Correction:** Replace fuse (10 amp) or reset circuit breaker. Search for cause of blown condition.

**Probable Cause:** Disconnected or bad fuel pump switch.

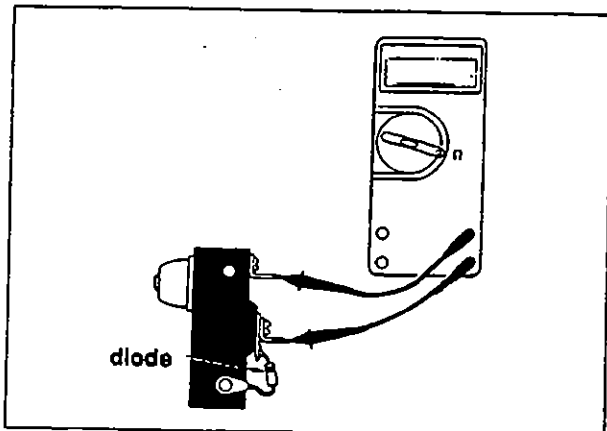

Fig. 1.1.33

**Correction:** Check that connections are made and are tight. Check for corrosion on terminals and clean as required. Check function of fuel pump switch. With the switch open, the VOM should register an "O.L." condition (Fig. 1.1.33). With the switch closed (plunger released), the VOM should register continuity. Replace as needed.

**Probable Cause:** Disconnected or failed clutch switch.

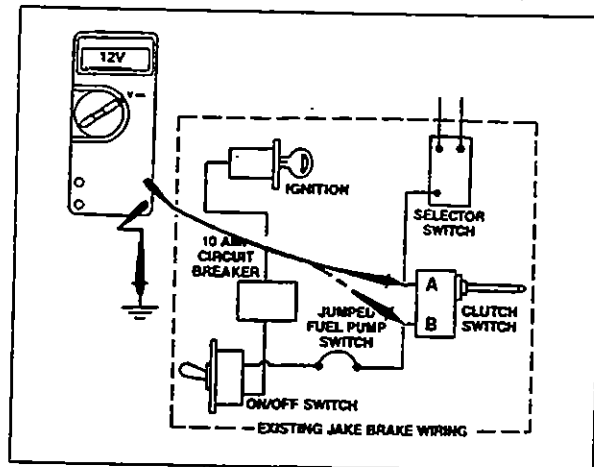

Fig. 1.1.34

**Correction:** Check that connections are tight on the clutch switch terminals. Check that there is no corrosion on connectors. Clean or replace as required. Check the clutch switch. With ignition ON and the Jacobs ON/OFF switch ON, measure the voltage at "A" (Fig. 1.1.34). VOM should read +12.5 VDC. At position "B" with switch closed, VOM should measure +12.5 VDC; with switch open, 0 VDC at position "B".

**Probable Cause:** Disconnected or failed selector switch.

**Correction:** Selector switch LO: 12.5 +/- 1 VDC must be applied to the purple wire to activate the blue solenoid output wire.

Selector switch MED/HI: 12.5 +/- 1 VDC must be applied to the gray wire to activate the yellow solenoid output wire.



**Probable Cause:** Orange wire grounded.

**Correction:** ABS (Aux) connection High: Orange wire for normal operation is not used. If connected to VOM, reading should be +5 VDC. If connected to ground, engine brake will not operate.

**Probable Cause:** Pink/white wire not grounded.

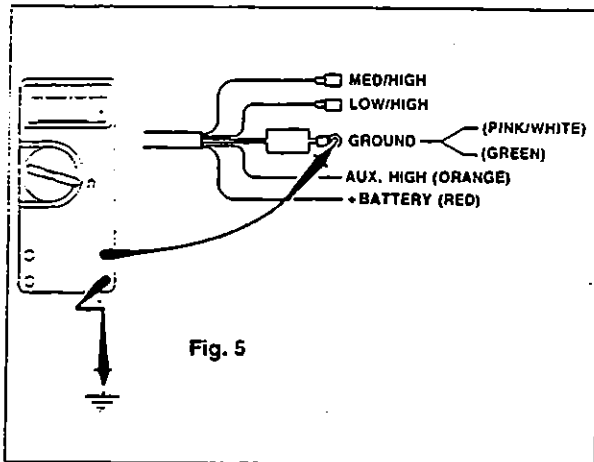

Fig. 5

Fig. 1.1.35

**Correction:** ABS connection LOW: Pink/white wire is, for most applications, connected to ground with the green wire. If not connected to ground, brakes will not operate. VOM reading when not connected should be +5 VDC (Fig. 1.1.35).

**Probable Cause:** Green wire not grounded or inadequately grounded.

**Correction:** Ground reference must be 1 ohm or less measure with VOM.

**Probable Cause:** Trim wires not properly cut.

**Correction:** Check application chart (Fig. 1.1.31) for proper wires to be cut.

**Probable Cause:** Failed or disconnected tach sender.

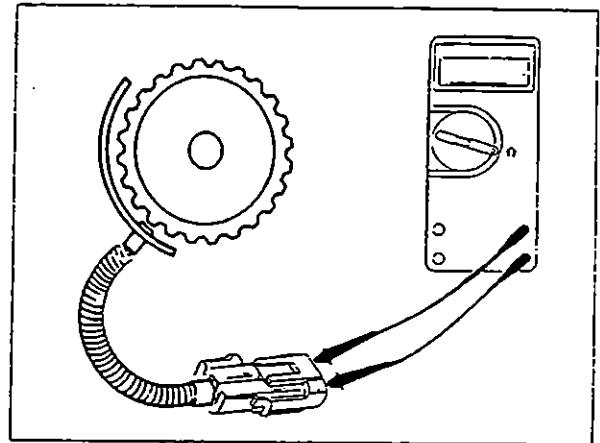

Fig. 1.1.36

**Correction:** Check that connections are tight with no evidence of corrosion. Disconnect harness at the control module. Measure resistance between tach sender wires; 50 - 300 ohms is a good reading (Fig. 1.1.36). The Motorola 7EP2033 or Volvo/White 13603-0013 will read 245-255 ohms.

Readings outside the accepted range indicate a short circuit or broken wire.

The sensor must be properly adjusted to manufacturers' specifications to generate the proper signal.

**Probable Cause:** Bad control module.

**Correction:** If all the above steps check OK, replace control module.

**Problem:** Brake modulation does not work properly.

**Probable Cause:** Gray and purple input wires not connected or improperly connected to switch.

**Correction:** Check for tight connections and no corrosion.

- Gray wire to MED/HIGH selector position.
- Purple to LO selector position.

**Probable Cause: Selector switch failure.**

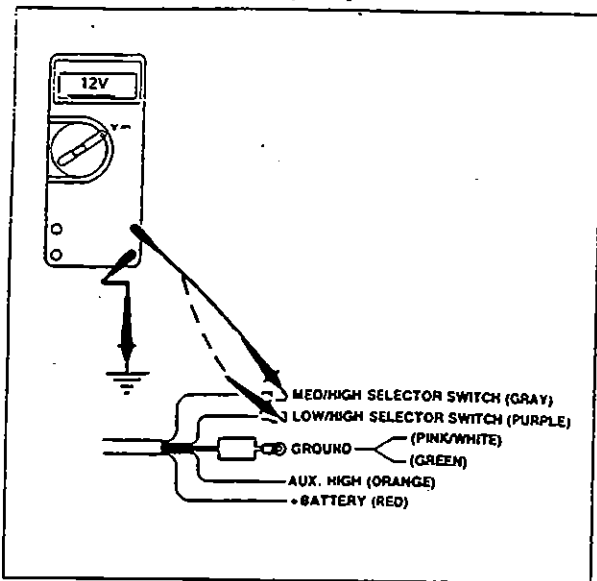

Fig. 1.1.37

**Correction:** With the selector switch in LO position, ignition ON and ON/OFF switch ON, measure voltage output at purple wire (Fig. 1.1.37). Proper reading should be 12.5 +/- 1 VDC. Measure output at gray wire. Output should be 0 VDC. Select HI position on selector. VOM should read 12.5 +/- 1 VDC at each output terminal.

**Probable Cause: Blue and yellow output wires disconnected or reversed.**

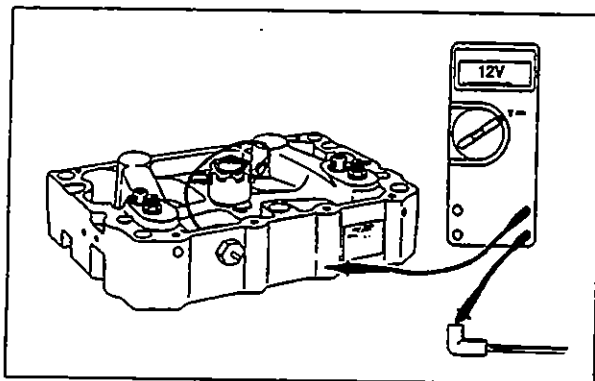

Fig. 1.1.38

**Correction:** Check to be sure connectors are tight and there are no signs of corrosion. Check that the blue wire is attached to the center housing (3-housing installation) or the rear housing (2-housing installation). Insure the yellow harness is attached to the front or first and third housings.

With the engine operating, transmission in neutral, dash switch on, selector switch on high, accelerate engine to high idle and then release throttle. The VOM readings at the blue and yellow wires should be 12 VDC (Fig. 1.1.38).

Check that 12 VDC is present at housing connector(s). If engine brake does not operate, remove valve cover(s).

**Probable Cause: Solenoid valve does not function.**

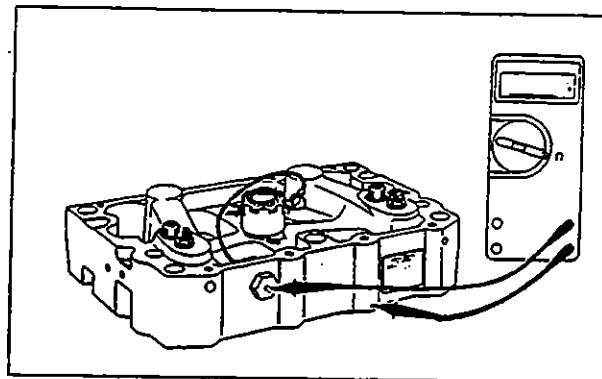

Fig. 1.1.39

**Correction:** Check to be sure solenoid harness is properly connected.

With electrical power OFF, check resistance of solenoid coil. VOM should read 9.75 - 10.75 ohms (Fig. 1.1.39). If it does not, replace solenoid valve.

**Problem: Engine Brake operation erratic.**

**Probable Cause: Improper ground.**

**Correction:** Using the VOM, measure the resistance from the point the green wire if grounded to the engine block. Resistance must be no greater than 1 ohm. If resistance is greater than 1 ohm, the ground wire must be repositioned to the engine block.

The green ground and the pink/white wire must be grounded alone. Grounding with other components at a common point may lead to "phantom" signals causing erratic operation.

**Probable Cause:** Improper or insufficient tach signal.

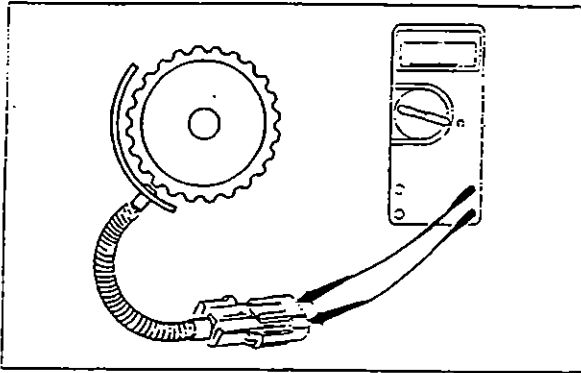

Fig. 1.1.40

**Correction:** Disconnect Weather Pack connector from Jacobs control module. Measure the resistance between the two wires from the tach sender (Fig. 1.1.40). An acceptable reading will be from 50 to 300 ohms. The Motorola 7EP2033 or Volvo/White 13603-0013 will read between 245-255 ohms. Readings outside this range indicate a short circuit or broken wires.

**Probable Cause:** Check that the tach sender is properly adjusted.

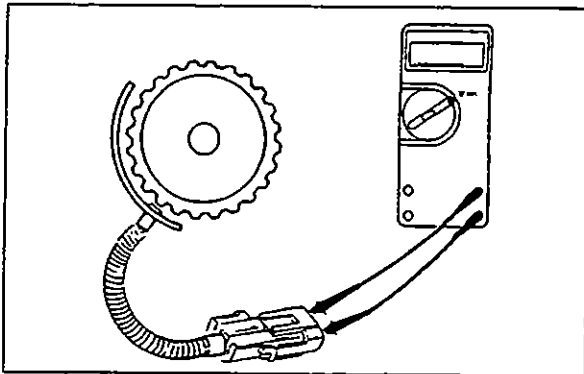

Fig. 1.1.41

**Correction:** With engine running, measure AC voltage signal between 500-800 RPM and record reading (Fig. 1.1.41). Above 1000 RPM, the VAC should be greater. If it is not, replace the sending unit.

**Probable Cause:** Insufficient tach ground

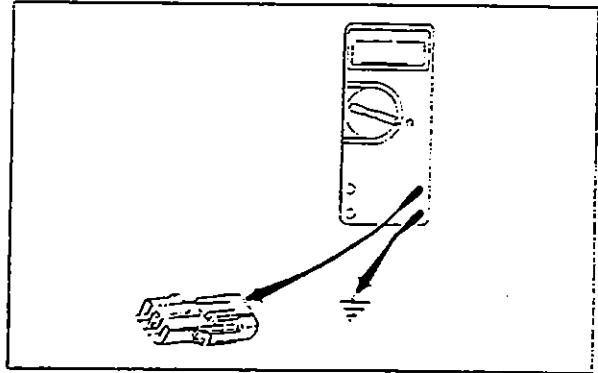

Fig. 1.1.42

**Correction:** Measure the resistance of each tach sender wire to ground (Fig. 1.1.42). The one wire with a reading of 0 ohms is at ground potential. This wire should be cut and the two ends insulated. If the problem continues, add a separate sending unit for the low speed signal.

# Wiring Diagrams for Cummins CELECT

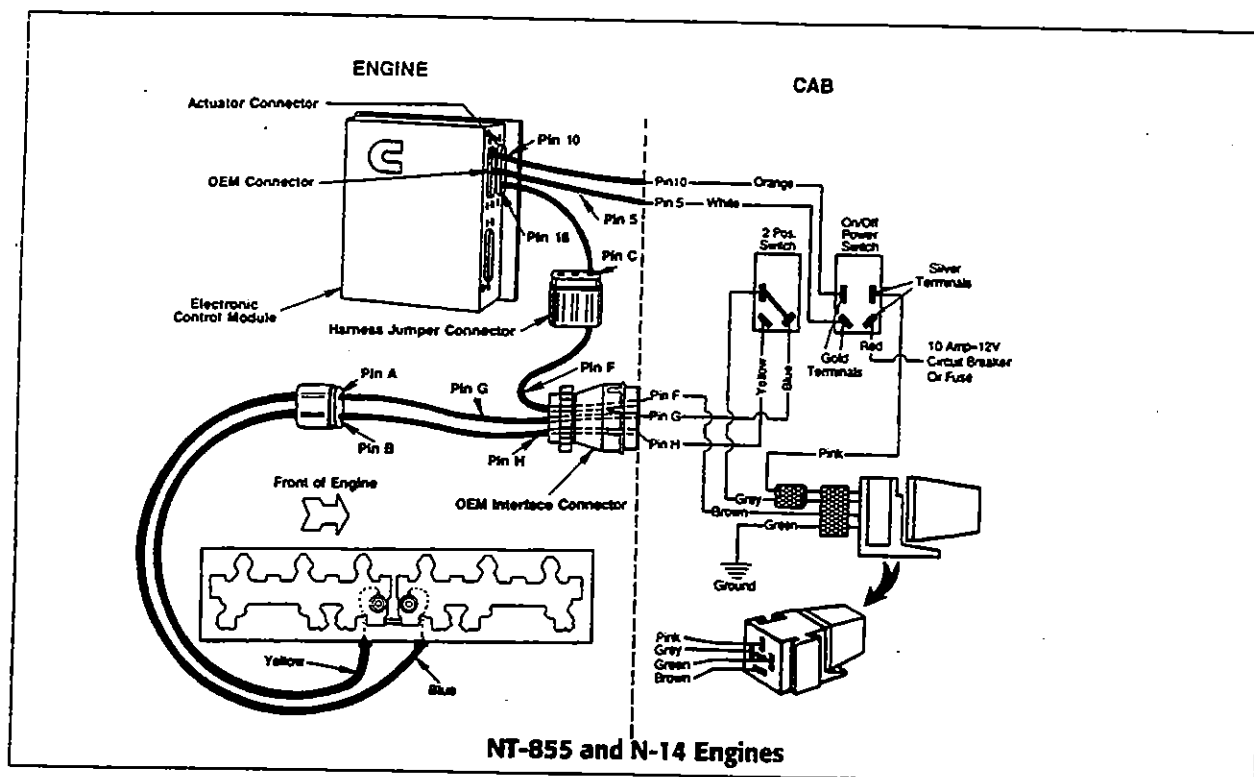

Fig. 1.1.43

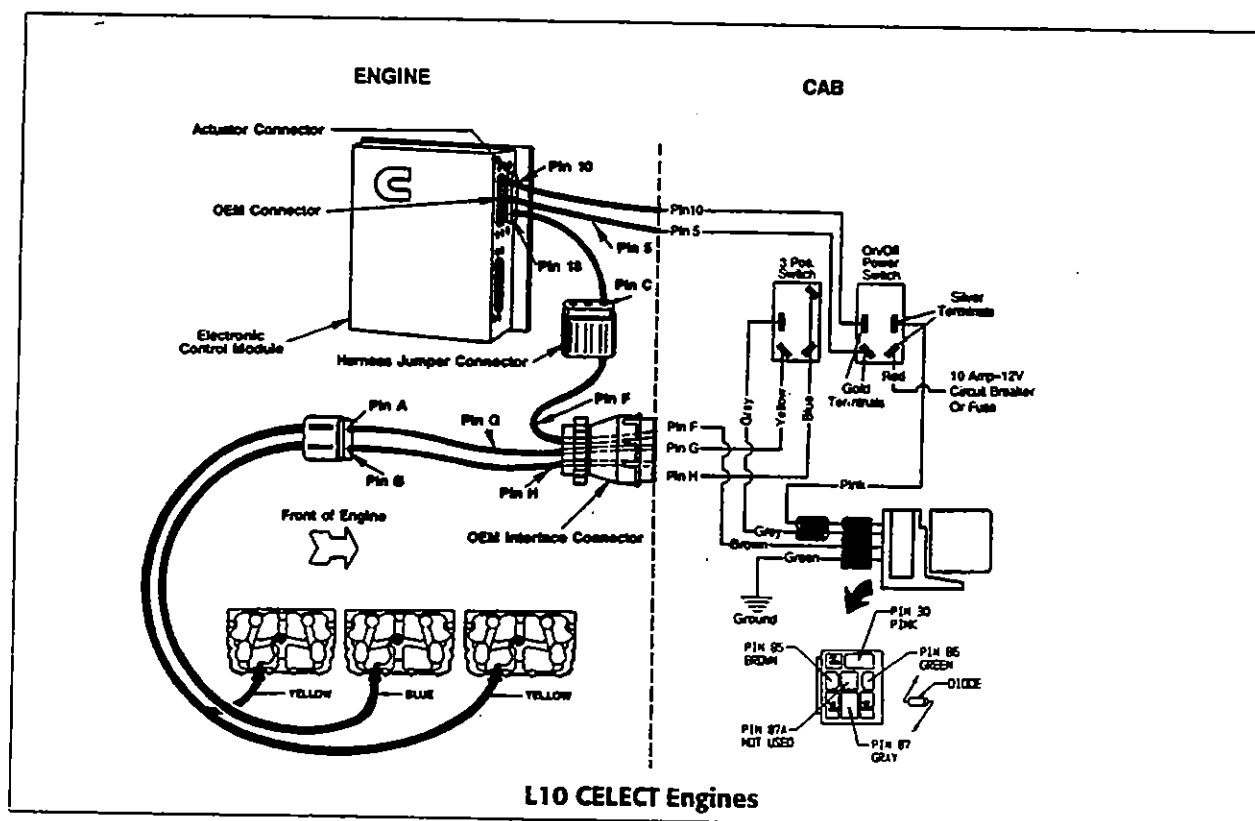
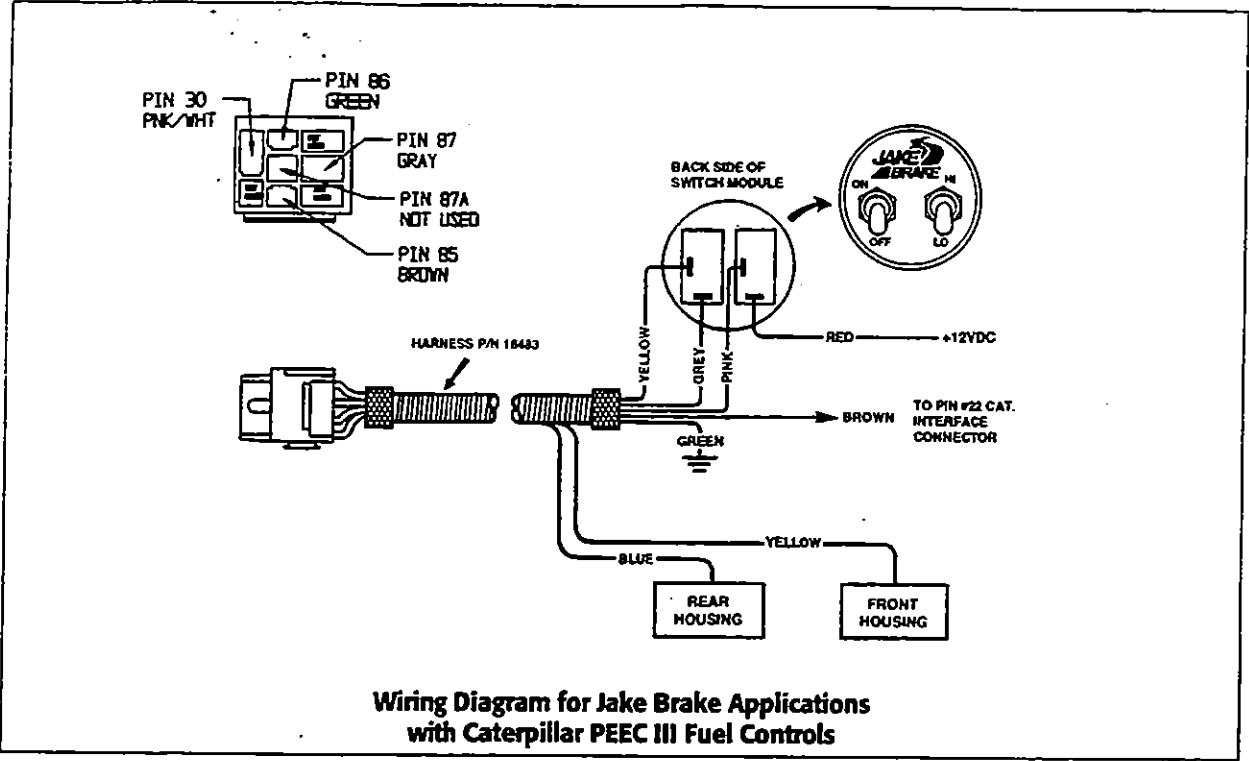
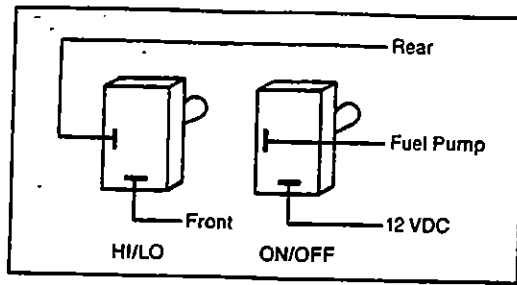

Fig. 1.1.44



**Wiring Diagram for Jake Brake Applications  
with Caterpillar PEEC III Fuel Controls**

Fig. 1.1.45



**TWO-DASH SWITCH CONFIGURATION**

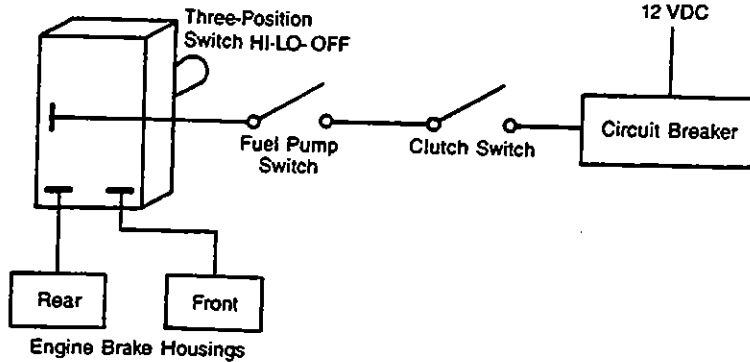

**Basic Wiring Diagram for Non-electronic 2-mode System**

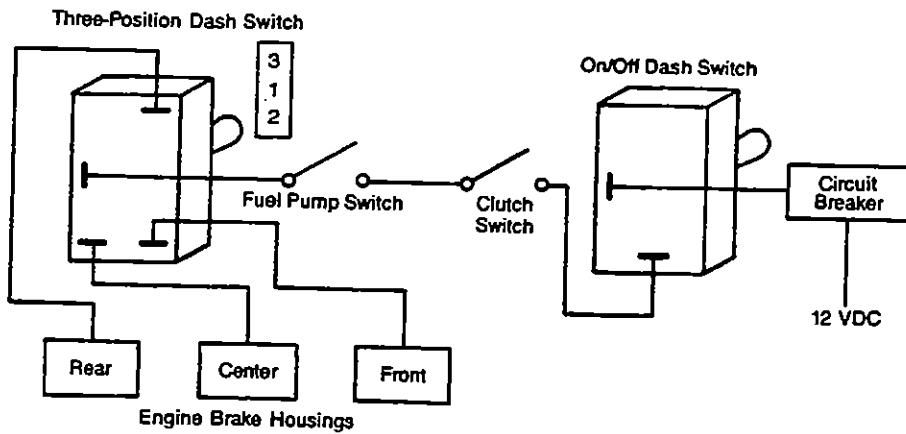

**Basic Wiring Diagram for Non-electronic 3-mode System**

Fig. 1.1.46

## 1.2 Hydraulic/Mechanical

### Theory of Operation

When an engine brake is energized, a power-producing diesel engine is converted into a power-absorbing air compressor. As shown in the schematic diagrams below, this is accomplished by the motion of a master-slave piston arrangement. Near the top of the normal compression stroke, the cylinder exhaust valves open releasing a compressed, cylinder charge to the exhaust system, preventing the engine from producing positive power.

### Operational Sequence

#### Step 1 (Fig. 1.2.1)

The main components of the hydraulic system are the solenoid valve, the control valve, the master piston and the slave piston. The control valve and the solenoid valve regulate the flow of the engine oil which acts as the Jake's hydraulic fluid. As shown in this figure, when the Jake is not in operation, the solenoid valve is closed, preventing engine oil from entering the system and allowing oil to drain to the sump from the previous operation.

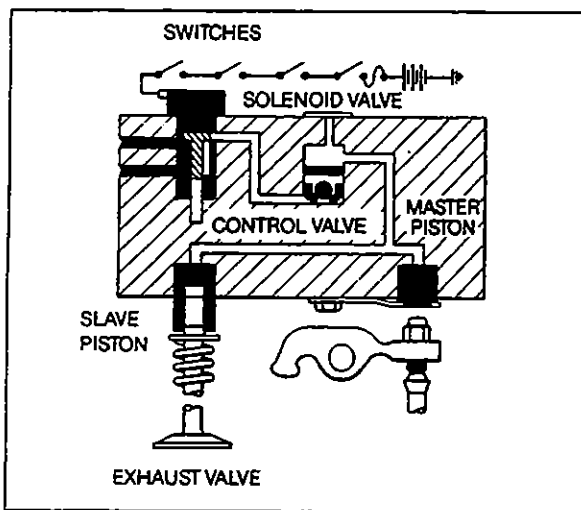

Fig. 1.2.1

#### Step 2 (Fig. 1.2.2)

When the solenoid valve is actuated, oil fills the passageway to the control valve. This exerts enough force to raise the control valve inside its bore and unseat the check ball inside the control valve. Engine oil then flows out through the control valve cross-port, fills the passageway between the slave and master pistons, and forces the master piston down against the injector rocker lever adjusting screw, or in some engines, the exhaust rocker lever adjusting screw of an alternate cylinder. This sequence connects engine camshaft motion to engine brake timing.

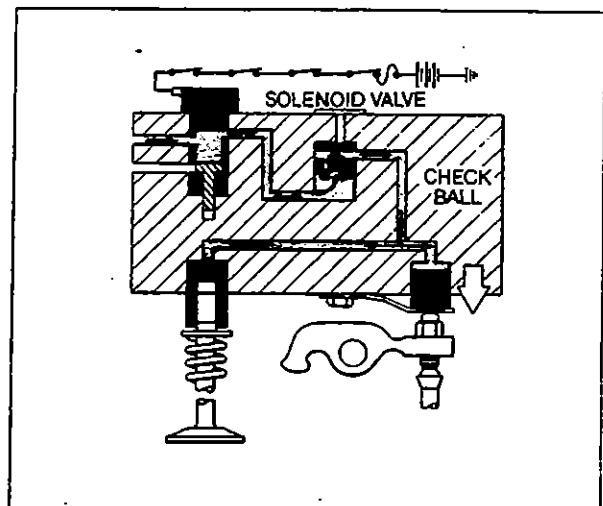

Fig. 1.2.2

#### Step 3 (Fig. 1.2.3)

When the rocker lever adjusting screw contacts the master piston, oil pressure increases and seats the check ball in the control valve. This creates a closed hydraulic system between the slave and master pistons. The oil pressure in the closed system increases and forces the slave piston down against the exhaust valve crosshead (bridge). The exhaust valves then open just before the engine piston reaches top dead center, releasing compressed air from the cylinder.

When electrical power is discontinued to the solenoid valve, engine lube oil is blocked from entering the brake housing. The inner control valve spring forces the control valve to the bottom of the control valve bore. The entrapped oil from the master piston/slave piston circuit can now escape from under the control valve cover, ending the engine brake cycle.

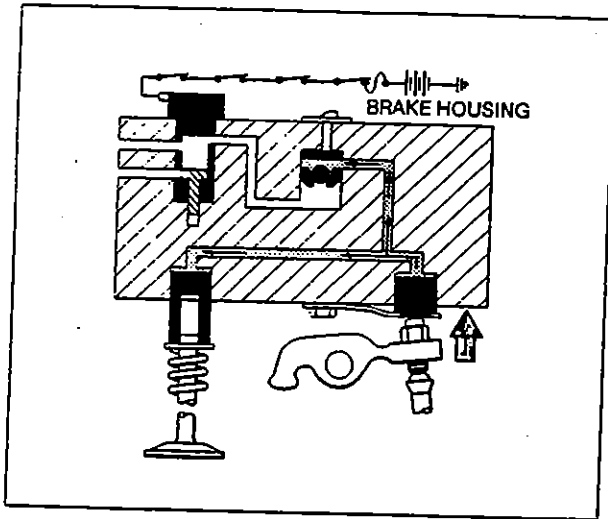

Fig. 1.2.3

## Brake Housings and Rocker Groups Inspection

1. Before inspecting the brake housings and rocker groups, remove over-engine equipment such as air intake and turbocharger crossover pipes, plus the valve mechanism upper covers. With the valve covers removed, start the engine and let the engine warm up to operating temperature. Manually depress the solenoid cap and make the following checks
  - a. In Models 53/71/92 series, Models 59/903, 336 and Model 404, check all oil connector screws and seals to ensure that oil is being transferred to the adjacent housings and screws are not loose or broken.
  - b. Inspect the nylock plugs on housing ends where applicable to make sure none are leaking.
  - c. As solenoid cap is depressed, check master piston assemblies to ensure that no binding occurs and all drop from their respective bores evenly and immediately.



Wear eye protection and do not expose your face over engine area. Take precautions to prevent oil leakage down on the engine.

Whenever engine is running and valve covers are removed, oil splashing in the engine brake area could cause personal injury.

### NOTE:

In some cases, idle oil pressure is not adequate to operate the engine brake (see Fig 1.2.5 for oil pressure requirements).

If this condition exists, raise the RPMs by using the throttle. Release the throttle and then manually depress the solenoid.

- d. Look for any cracks in the engine brake housings.
  - e. Look for leaks from the solenoid upper seal area.
2. Release solenoid cap and check for:
    - a. Immediate shut off. Check the condition of oil exhausted from the control valve cover. If exhausted oil has bubbles or is foamy in appearance, air is present in the system. Repeat this procedure several times. If aeration continues, the source of aeration must be determined before continuing with diagnostic procedures. Aeration causes a spongy brake because of reduced piston travel.
    - b. Quick and complete master piston retraction.

## Engine Brake Housing Oil Pressure Check

To properly troubleshoot the engine brake, the mechanic must know the supply oil pressure reading to the engine brake housing. The mechanic must understand that the oil pressure reading on the instrument panel gauge is not the same as at the engine brake housings.



Insufficient oil pressure to compress the control valve return spring or to cause deflection of the master piston return spring will prevent the brake from working. Partial or incomplete compression and deflection of these springs from marginal oil pressure supply will produce marginal, if any, brake performance.

**NOTE:**

When making oil pressure checks on Jacobs Models 401,404 and 760 (not 760A or 765), it is necessary to start at idle speed and then gradually increase RPMs. The one way check valve in the housing entrance prevents the total escape of engine oil. If full RPM oil pressure is taken first, that pressure is accurate. However, when the RPMs are lowered, there is enough entrapped oil to give an artificially higher reading. To correct this condition, loosen the solenoid adapters and allow the pressure to bleed down, then retighten the adapter and record the pressure. Shut down the engine before loosening the solenoid.

If oil pressure is insufficient for engine brake operation, the engine should be examined by an authorized facility. Oil may be leaking past cam bearings, rocker bushings, or other oil-pressure-fed engine bearings, if worn. This can produce insufficient oil supply to operate engine brakes. Brakes could operate at higher RPM levels, but fade out at lower RPM levels.

On some of today's new diesel engines which operate at lower average regulated oil pressures, oil pressure values below 1000 RPM are not of great concern. Below this engine speed, the engine brake is least efficient. The old standard that the engine brake should stall the engine at idle as a troubleshooting technique is now outdated.

High oil pressure or "over pressure" can also cause poor braking by forcing the control valves to shut off the engine brake units. This can occur on models that have the control valve double spring over-pressure system. The double spring system allows the control valve to shut off the engine brake before oil pressure reaches a level which can cause the slave piston to jack.

See Fig. 1.2.5 for specific oil pressure requirements for the control valve springs used in the brake model you are working on.

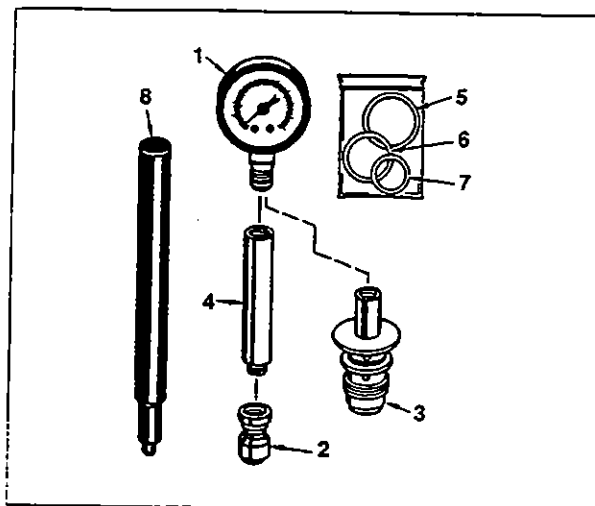

Fig. 1.2.4

**Oil Pressure Test Kit, P/N 018280**

Ill. No.	Part Name
1	Pressure Gauge
2	Body, Control Valve - Pressure Test
3	Solenoid Valve - Pressure Test
4	Adaptor - Pressure Test
5	Solenoid Seal Ring
6	Solenoid Seal Ring
7	Solenoid Seal Ring
8	Control Valve Cover Removal Tool
NI	Tool Box
NI	Instructions - Pressure Test
NI	Chart, Oil Pressure

The tools in this kit can be used to determine engine oil pressure available for operation of any model Jacobs engine brake. Complete instructions are contained in the kit.



To prevent personal injury, wear safety glasses and use caution when working on an engine. When engine is running, cover open areas with towels to reduce oil spray.

## Preliminary Checks

1. Before starting engine, check the following:
  - a. Oil level on dipstick. Overfull or underfull condition in crankcase will cause aeration in the engine brake hydraulic system.  
If oil level is questionable, refer to manufacturer's charts for correct dipstick calibration. Re-calibrate if necessary.
  - b. Condition of engine lubricating oil for presence of fuel or water or both. This indicates engine problems and must be corrected.
2. Check engine brake slave piston setting and engine valve injector settings. See applicable installation and service literature.
3. Weak, intermittent or no engine braking may be due to electrical, hydraulic or mechanical problems. Prior to using the test kit, check all electrical components, switches, wiring and slave piston adjustments.

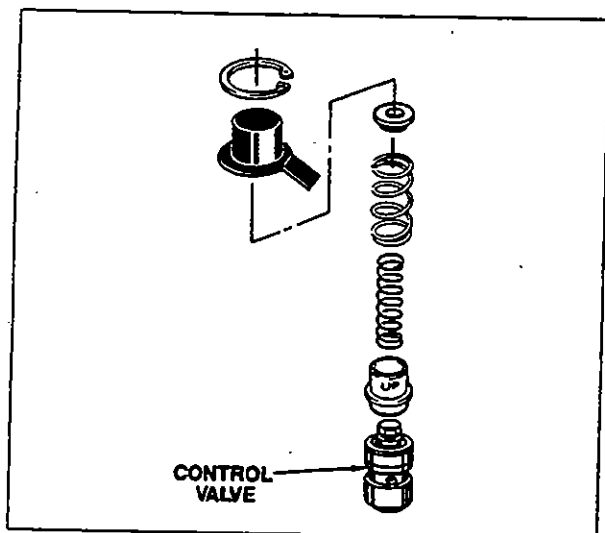

Fig. 1.25

**NOTE:**

Components used with the control valves in various engine brake models may differ (see Fig. 1.25). Be sure all parts are reinstalled in the same order as removed. Refer to installation manuals for specific models in question.

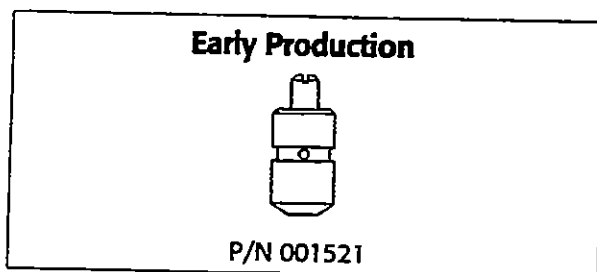

Fig. 1.26

## Control Valve Component Inspection



Remove control valve covers carefully. Control valve covers are under load from the control valve springs. Remove with care to avoid personal injury.

1. If any of the above problems are found, inspect the control valve components of the questionable cylinder for the following:
  - a. Broken control valve springs.
  - b. Smooth movement of the control valve in its bore.
  - c. Spring tension and check ball seating in the base of the control valve body.
2. Apply pressure to the control valve cover and slowly remove the hex head capscrew or snap ring. Slowly raise the cover until all spring pressure is relieved.
3. Remove the control valve springs and other components, if applicable.
4. Using needle-nose pliers or fingertips, reach into the bore and grasp the stem of the control valve. Pull the valve straight up and out of its bore. If binding occurs, clean or replace if necessary.

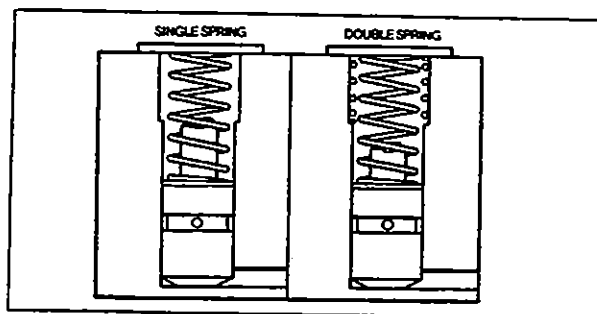

Fig. 1.27

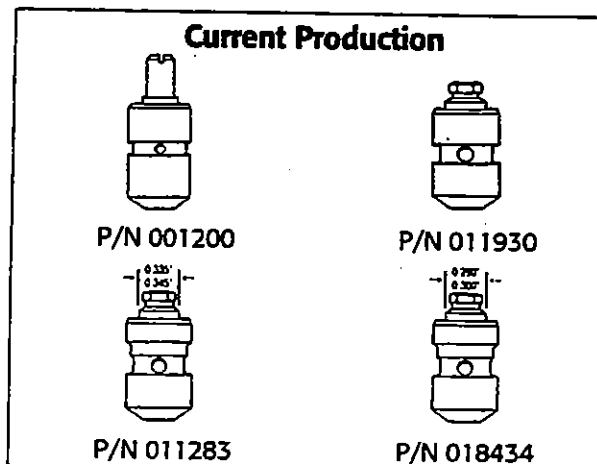

Fig. 1.28

## Engine Brake Oil Pressure Requirements



Do not intermix spring combinations.

### Current Production Engine Brake Models

Model	Control Valve	Control Valve Springs	Full Flow PSI	Over Pressure PSI
317B/C	018434	018179/011253	18-50	75
C336	011930	007500/010843	16-80	95
346D	011930	011435/011434	16-78	100
349/A	011930	011823/011434	20-87	95
404BG	011283	011823/011253	20-53	75
404D	011283	007500/011253	25-56	78
425A	011930	007500/001519	22-53	65
430	011930	007500/010843	16-80	95
440/445	011930	007500/011253	25-65	70
680A	011930	003109/010843	35-90	110
680B	011930	011823/010843	25-85	90
71/92A	011930	007500/011434	15-77	85
760A/765	011930	001518/001519	25-56	78
122	011930	011823/010843	20-85	100

### Past Product Engine Brake Models

C317A	011283	001518/011253	25 - 56	78
C346	001200	001518	25+	N/A
C346B/C	011930	011435/011434	16 - 78	100
20	001200	001012	20 - 58	N/A
30/25B	001521*	001518/001519	25 - 56	78
30E	011283	007500/001519	15 - 54	66
59/59A	001521	003109/003110	35 - 78	92
59B	001521	003109/010843	35 - 104	110
903	001200	001518	25+	N/A
K200	001200	003410	6+	N/A
K1150	001200	006536	16+	N/A
K1200	001521	007500/001519	15 - 54	66
400, 400H	011283	007500/001519	15 - 54	66
401A/B/C	007505*	007500/011253	15 - 46	65
404/404B	011283	011823/011253	20 - 53	75
404C	011283	007500/011253	25 - 56	78
425/420	011930	007500/001519	22 - 53	65
675	001200	001518	25+	N/A
675A	011930	011435/011434	16 - 78	100
53A	011930	001012/001519	22 - 53	65
760	011930	001518/001519	25 - 56	78

\* The Jacobs control valve, P/N 007505, has been superseded by P/N 011283. The Jacobs control valve, P/N 001521, has been superseded by P/N 011930.

Fig. 1.2.9

# NOTES

## 1.3 General Problem Analysis

### Tools and Parts Available for Servicing and Maintaining Jacobs Engine Brakes

#### Tool Box

Tool Box for All Models: P/N 017469

Tool Boxes for Engine Families:

Caterpillar: P/N 017465

Cummins: P/N 017468

Detroit Diesel: P/N 017466

Mack: P/N 017467

Tool Box only: P/N 017471

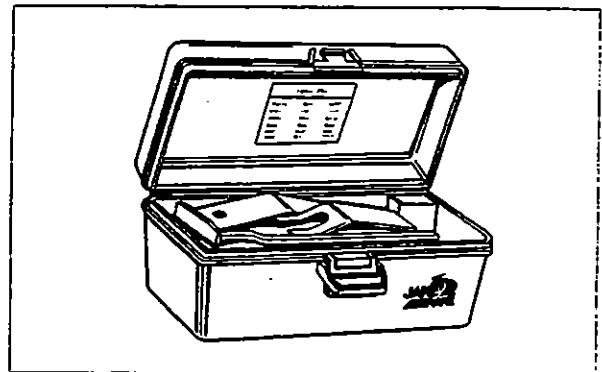

#### Oil Pressure Test Kit

Use for all Jake Brake models to troubleshoot weak and/or no engine brake conditions.

Check engine oil supply pressure at the engine brake solenoid valve and the control valve.

Pressure gauge, three adaptors, seals and control valve cover release tool packaged in a sturdy case.

Includes laminated chart with specifications for all past and current models.



#### Tune-up Kits

Genuine Jacobs replacement parts.

Everything needed for a complete tune-up in one convenient package.

Complete step-by-step instructions.

All parts include the latest Jacobs design improvements.

All parts backed by full Jacobs replacement parts warranty.

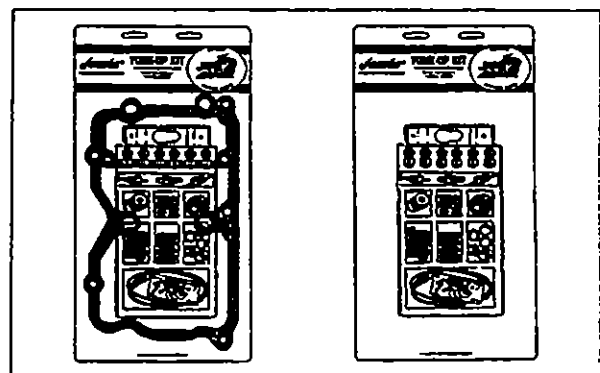

### **Problem: Engine fails to start**

**Probable Cause:** Solenoid valve stuck in "on" position.

**Correction:** Ensure that electrical current is off to engine brakes. If solenoid valve remains "on" (cap down) with current off, replace solenoid valve.

### **Problem: Engine brake will not operate**

**Probable Cause:** Blown fuse, open electrical leads.

**Correction:** Look for short circuit in wiring. Replace any broken, brittle or chafed wires. Check solenoid tab for signs of shorting; replace if necessary. Replace fuse (10 amp).

**Probable Cause:** On/off switch, clutch switch, throttle switch or multi-position switch out of adjustment or defective.

**Correction:** Use a volt/ohm meter to make certain that there is electrical current available at both terminals of each switch. Readjust if needed or replace if voltage will not pass through switch.



Do not touch electrical connection when system is energized.

**Probable Cause:** Incorrect electrical power source.

**Correction:** Power supply must be a minimum of 12 VDC. Recommended power source is from the key switch "on" position. Ensure that power is not taken from a source with an additional on/off switch, i.e., light switch. Make sure wiring is in accordance with Jacobs installation manual for brake model.

**Probable Cause:** Low engine oil pressure.

**Correction:** Determine oil pressure at engine brakes using procedures given in this manual (see Section 1.2 for oil pressure requirements). If oil pressure is below specifications, engine should be repaired in accordance with manufacturers' procedures.

### **Problem: Engine brake activates with switches open (off)**

**Probable Cause:** Center solenoid valve seal ring damaged.

**Correction:** Remove solenoid. Replace all seal rings.

**Probable Cause:** Engine brake improperly wired.

**Correction:** Check wiring in accordance with Jacobs wiring diagrams.

### **Problem: Engine brake slow to operate or weak in effect**

**Probable Cause:** Lube oil cold and thick.

**Correction:** Allow engine to warm before operating brakes.

**Probable Cause:** Improper slave piston adjustment or slave piston binding in bore.

**Correction:** Readjust in accordance with Jacobs procedures for model brake in question. Ensure that slave piston responds smoothly to the adjusting screw by loosening jam nut and screwing the screw through its full travel for full slave piston motion. Make sure piston travels full range without binding or sticking.



Remove slave piston carefully when disassembly is necessary. Use either an arbor press or "C" clamp. Slave piston springs are under heavy compression.

**Probable Cause:** Lower solenoid seal damaged, allowing oil to exit housing.

**Correction:** Remove solenoid valve and replace all seal rings.

**Probable Cause:** Solenoid screen clogged, stopping supply of oil to brake.

**Correction:** Remove solenoid valve and clean or replace screen.

## **Problem: Engine brake slow to operate or weak in effect (cont.)**

**Probable Cause:** Master piston not moving in bore.

**Correction:** Inspect master piston and bore for scoring or burrs. If any present, clean surface with crocus cloth. If unable to remove burrs, replace piston or housing. Inspect lube oil for signs of contaminants. If any are present, replace oil and filters and correct cause of contamination.

**Probable Cause:** Control valves binding in housing bore.

**Correction:** Remove control valve. If body is scored, replace control valve. Check for contaminants in lube oil. Clean housing and control valve. If binding continues, replace housing.

**Probable Cause:** Control valve defective.

**Correction:** Remove control valve. Make sure check ball is seated in bore and can be moved off seat. Make sure there is spring pressure against ball. Flush in cleaning solvent. Replace if necessary.

**Probable Cause:** Switch operation sluggish. Check dash switches, clutch switch, throttle switch.

**Correction:** Readjust or replace switch. Check throttle or clutch return springs for proper operation. On 71/92A, ensure engine is going to "no fuel" position and governor riser bearing is allowing free governor operation.

**Probable Cause:** Solenoid valve operation erratic

**Correction:** Check solenoid valve using electrical specifications explained in this manual or, with key on, brake switches on, and engine off, activate solenoid electrically. Ensure solenoid cap depresses



Do not touch electrical connection when system is energized.

**Probable Cause:** Engine brake housing plugs leaking.

**Correction:** Check plugs for signs of leaks. If leaks are present, remove plug, clean threads and install at 100 lbin. (11 N•m) torque. Use Jacobs plugs.

**Probable Cause:** Outer control valve spring broken, or engine oil pressure extremely high (see Section 1.2).

**Correction:** Outer control valve spring broken, allowing control valve to over-index. Problem is engine lube system. Consult appropriate engine repair manual for causes of high lube oil pressure.

## **Problem: Oil pressure dropping below minimum required for engine brake operation**

**Probable Cause:** Upper solenoid seal ring damaged.

**Correction:** Remove solenoid. Inspect seal ring and replace all seal rings.

**Probable Cause:** Damaged oil supply seals under or between housings.

**Correction:** Remove housing and replace seals. Inspect for cracked or broken oil connectors, replace seals.

**Probable Cause:** Aeration of lubricating oil.

**Correction:** Check for aeration of the oil. Activate, then deactivate engine brake. Watch escape oil coming from control valve cover. If oil has bubbles or if foamy, air is present in system. Aeration can be caused by an overfull or underfull crankcase, crack in oil pickup tube or leaks in oil suction tube or hose. Correct in accordance with manufacturer's procedures.

**Probable Cause:** Lubricating oil being diluted by fuel oil.

**Correction:** Have an oil analysis of lube oil to determine if fuel is present. Correct per engine manufacturer's procedures.

**Probable Cause:** Low engine oil level.

**Correction:** Consult engine manual for specifications. Add oil or re-calibrate dipstick as required.

**Probable Cause:** Worn engine rocker lever bushings.

**Correction:** Replace bushings in accordance with engine manufacturer's procedures.

**Probable Cause:** Oil leaking from around cylinder head.

**Correction:** Repair causes of leaks.

**Probable Cause:** Restrictions in the oil passages leading to engine brake.

**Correction:** Inspect all the passageways, remove any items restricting oil flow.

**Probable Cause:** Models 401, 404 and 760 only (not 760A or 765). Check ball valve assembled inversely or more than one spring is used.

**Correction:** Remove check ball valve. Check number of springs used. Reassemble, using one spring, the following order. First insert spring. Then, replace ball, washer and retaining ring.

### **Problem: One or more cylinders fail to stop braking or engine stalls.**

**Probable Cause:** Control valve inner spring broken.

**Correction:** Replace inner spring.

**Probable Cause:** One or more control valves stuck in "on" or up position.

**Correction:** Check control valves for binding. Remove and clean or replace if necessary. Inspect lube oil for contaminants.

**Probable Cause:** Solenoid valve sticking in "on" position.

**Correction:** If solenoid valve cap remains down with no electric current being supplied, replace solenoid valve.

**Probable Cause:** Center solenoid seal ring damaged. Allows oil to enter brake with solenoid valve closed.

**Correction:** Remove solenoid and replace all seal rings.

**Probable Cause:** Solenoid valve exhaust plugged.

**Correction:** Remove any restrictions at exhaust (bottom) of solenoid valve.

**Probable Cause:** Clutch switch or throttle switch stuck in "on" position or out of adjustment.

**Correction:** Check for proper operation. Readjust or replace as needed.

### **Problem: Engine misses or loses power.**

**Probable Cause:** Slave piston adjustment too tight.

**Correction:** Readjust slave piston clearance in accordance with appropriate Jacobs installation manual.

**Probable Cause:** Insufficient clearance between exhaust crosshead and underside of exhaust rocker lever (Cummins engine applications only).

**Correction:** Pass a 0.020-inch wire gauge between back section of crosshead and underside of rocker lever. If 0.020-inch clearance cannot be obtained, change crosshead with another cylinder and re-measure. If clearance still cannot be obtained, check for bent crosshead guide pin or enlarged rocker lever. Replace as required.

**Probable Cause:** Auto-Lash® plunger in full extended position (Cummins engine applications only).

**Correction:** Check for over-torque of locknut. Re-torque to 25 lbft. maximum. If condition continues, replace Auto-Lash.

### **Problem: Sudden drop in engine lube oil pressure.**

**Probable Cause:** Oil inlet supply seal missing or damaged.

**Correction:** Replace seal.

**Probable Cause:** Upper solenoid valve seal missing or damaged.

**Correction:** Remove solenoid and replace upper seal ring.

**Probable Cause:** Models 71/92 and 53A, rapid dilution of lube oil caused by loose or cracked fuel pipes.

**Correction:** Inspect fuel pipes for proper torque (10 lbft.) or cracks at flare ends. Start engine. Pressure check heads for signs of more pipe leakage. Replace any showing signs of leakage.

**Probable Cause:** External oil supply hoses or fittings cracked and leaking.

**Correction:** Inspect all hoses and fittings for tightness, chafes or cuts. Replace or repair as necessary.

**Probable Cause:** Oil connectors between housings (where applicable) broken or leaking.

**Correction:** Inspect all oil connectors for cracks and broken or loose screws. Look for missing seals and seals that are brittle split or damaged. Replace as required.



# 1.4 Engine Brakes for Cummins Engines

## Two-valve Design

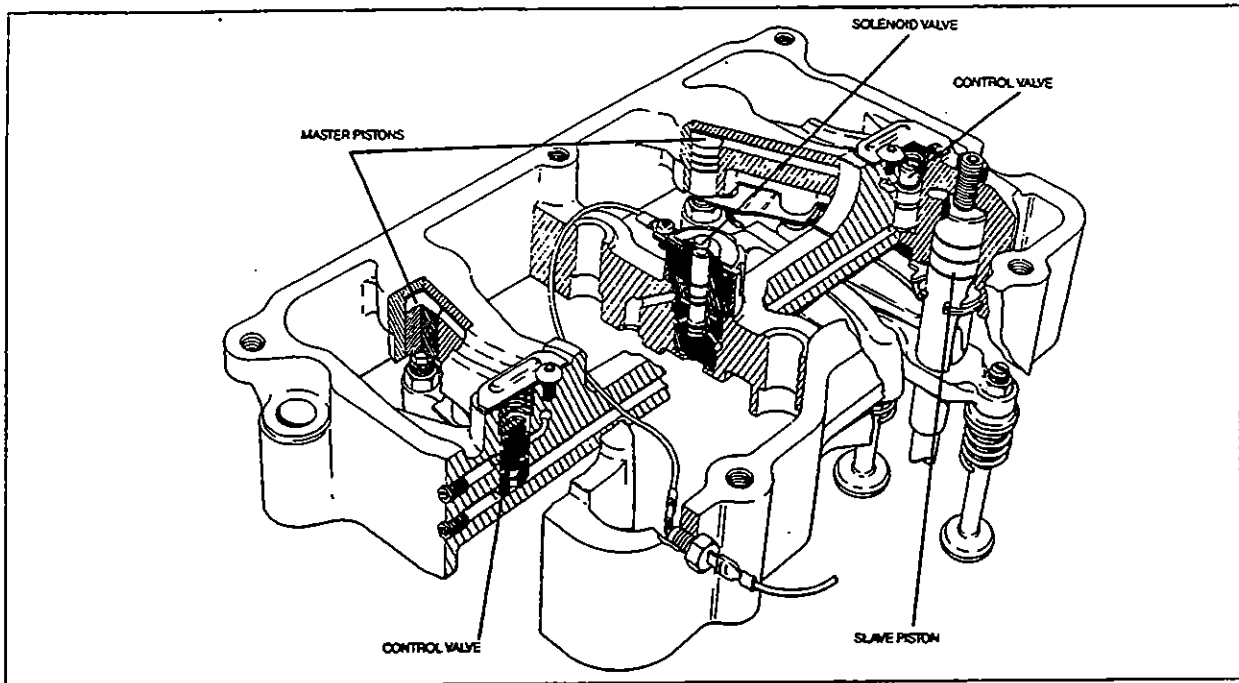

Fig. 1.4.1

### Current Production Models

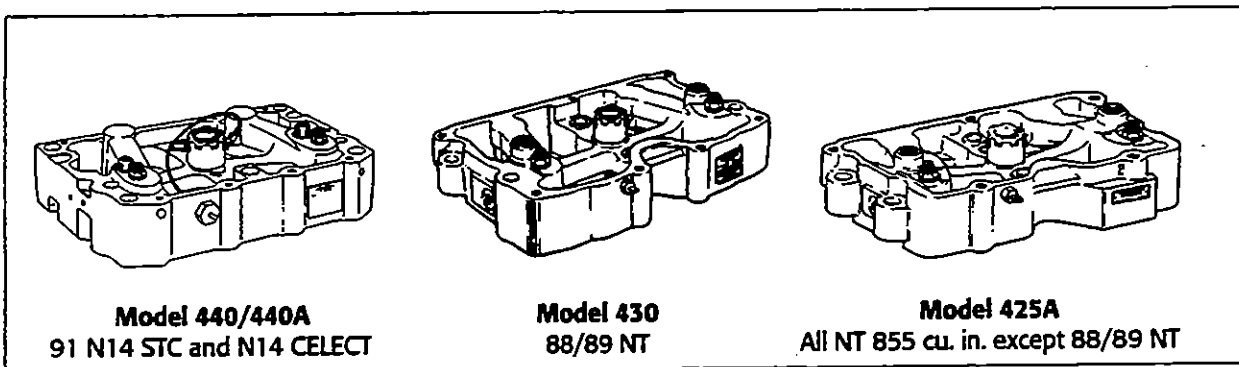

Fig. 1.4.2

Former engine brake models for Cummins NT-855 cu. in. engine applications:

25	25B	30	30E
30 SN (Spray Nozzle)	400	400H	

The former Models 401A/B/C single-valve design were also used for Cummins 855 CID engines (see Page 1.4.3).

For proper application information, refer to Jacobs Distributor or Jacobs Field Representative.

## Special Features

**Auto-Lash<sup>®</sup>:** Used in Jacobs Engine Brakes for Cummins Engines with two-valve operation only.

The Auto-Lash adjusting screws are designed to provide optimum exhaust valve opening during engine brake operation. Each engine brake model uses a different Auto-Lash; the distinguishing feature is the amount of plunger protrusion. The plunger protrusion amount is directly related to engine brake timing advancement.



Auto-Lashes cannot be intermixed.

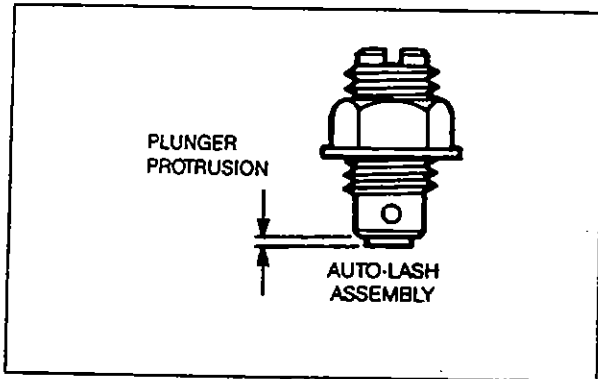

Fig. 1.4.3

## Part Number Identification & Matrix

Refer to specific engine brake model parts manual for proper Auto-Lash.

## Operation (example only)

Engine brake in "OFF" mode. Static setting of 0.018" clearance for normal engine operation.

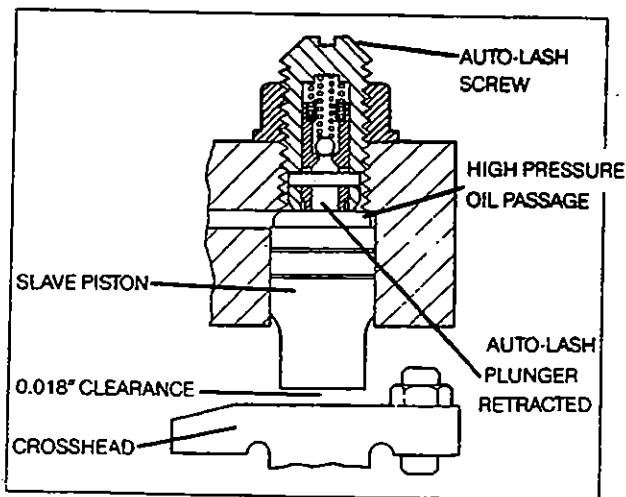

Fig. 1.4.4

Engine brake in "OPERATING" mode. Clearance of 0.009" for more valve opening.

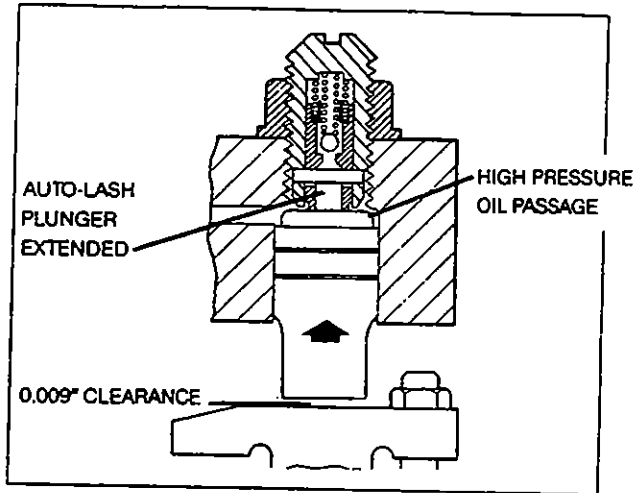

Fig. 1.4.5

Engine brake in "OPERATING" mode.

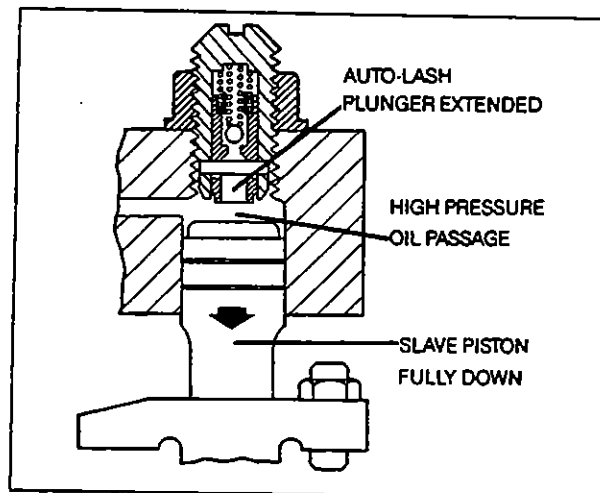
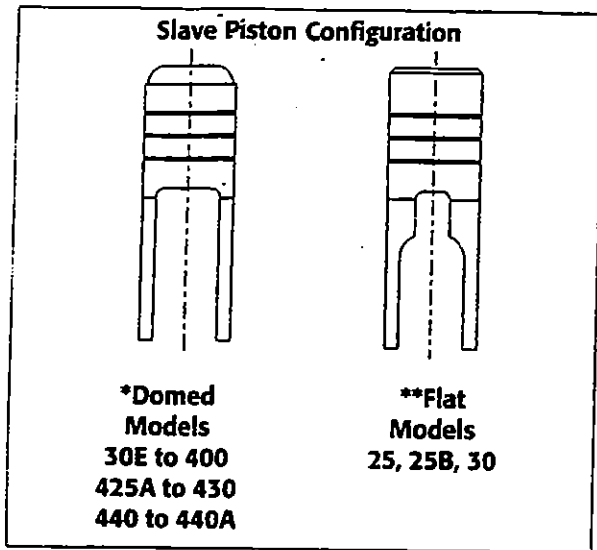

Fig. 1.4.6

During engine brake operation, the spring inside the Auto-Lash assembly moves the plunger out to its lowest position. Oil under pressure enters the Auto-Lash body through the hole in the plunger and "locks" the plunger in its extended position. This reduces the slave piston clearance from 0.018" to 0.009" (Model 400 Auto-Lash example) for most effective engine brake operation for this engine/engine brake model.

When the engine brake is shut off, the oil bleeds off and the plunger retracts from the force of the slave piston spring. The slave piston clearance returns to 0.018" for normal engine operation.



**Short Slave Piston Part Numbers for  
Reworked Cylinder Heads and Exhaust Valves**

	Domed*	Flat**	425A	430	440/ 440A
Stand.	007623	001484	014864	014864	017409
Short	007696	001486	017078	017078	017728

Short slave pistons may be required where cylinder heads and exhaust valves have been reworked. Valve stems may protrude too high above cylinder head to allow for sufficient slave piston-to-crosshead clearance.

Fig. 1.4.7

## Single-valve Design

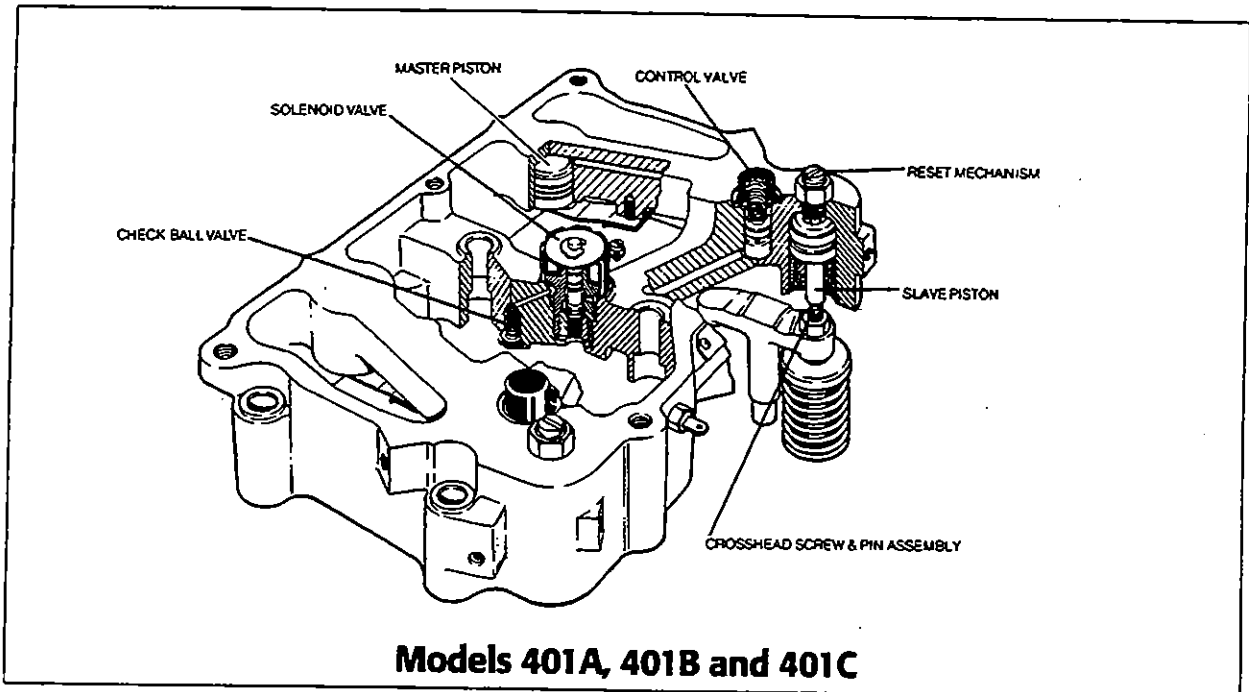

Fig. 1.4.8

Some early model engine brakes for 855 CID engines used a single-valve operating system. Only one exhaust valve per cylinder is opened during engine braking. The two-valve operation opens two exhaust valves.

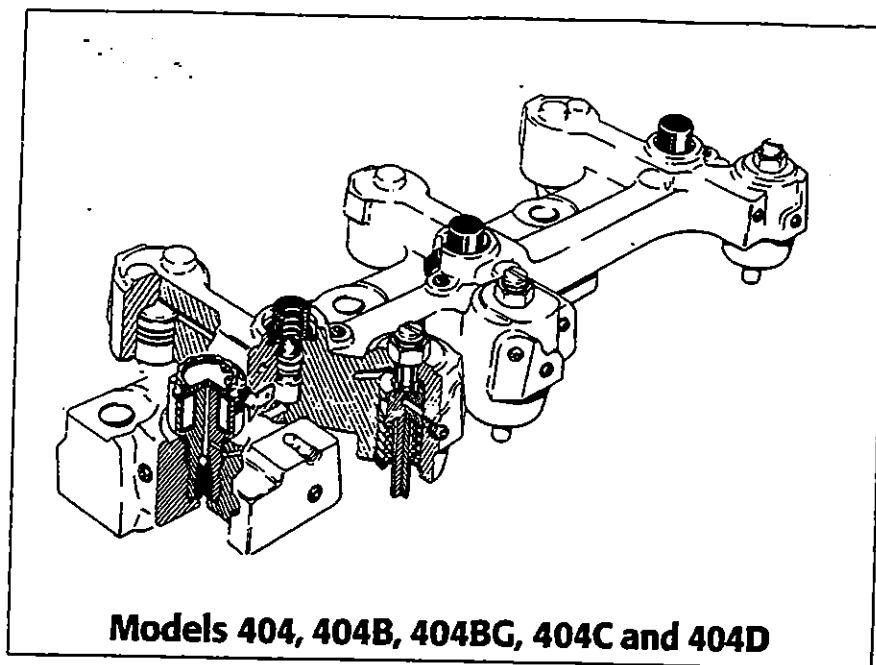

Fig. 1.4.9

The major difference between the brake models is the diameter of the master piston. Neither the master pistons nor the housings are interchangeable.

Model	Master Piston Diameter
401A	0.938 inch
401B	0.875 inch
401C	1.000 inch
404	0.875 inch
404B	0.875 inch
404BG	0.875 inch
404C	0.6875 inch
404D	0.6875 inch

## Special Features

### Guideless Crossheads

All 91L10 and later engines use guideless crossheads (Fig. 1.4.10).

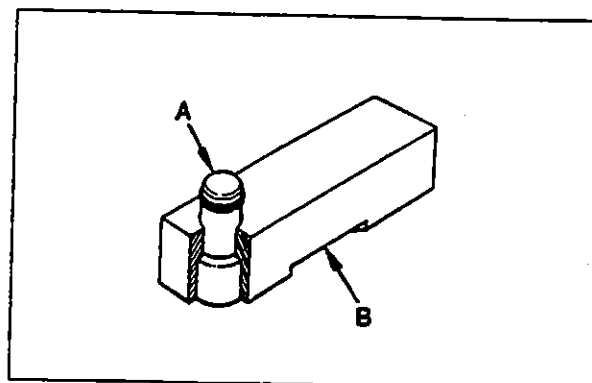
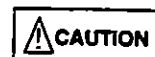

Fig. 1.4.10

- A. Jacobs retained actuator pin
- B. Jacobs guideless crosshead assembly



**Do not disassemble the actuator pin from the Jacobs crosshead. The assembly is made up of matched parts and must not be field serviced.**

Lubricate the actuator pins and valve stems with engine oil and install the Jacobs crossheads over the exhaust valves. Locate the actuator pins on the exhaust valves closest to the rocker shaft.

The crosshead should move freely from side to side, pivoting on the side without the actuator pin. No adjustment is required with guideless crossheads.

### Crosshead Screw and Pin Assembly

The crosshead pin assembly is a key component in the single-valve system. The pin assembly allows for only one valve to be opened by the engine brake slave piston. It allows for the re-use of the Cummins exhaust crosshead, simplifying installation. The pin assembly replaces the Cummins crosshead adjusting screw and nut and can be adjusted using Cummins procedures. The pin assembly requires no specific maintenance.

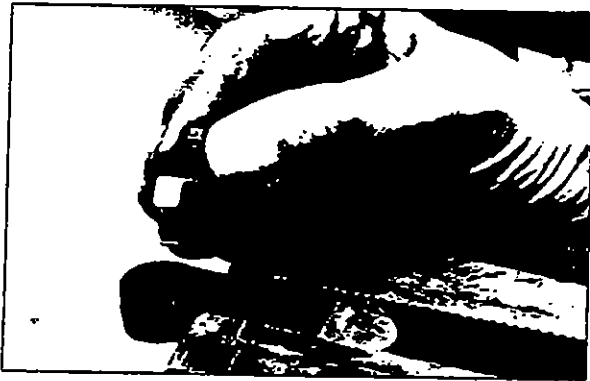

Fig. 1.4.10

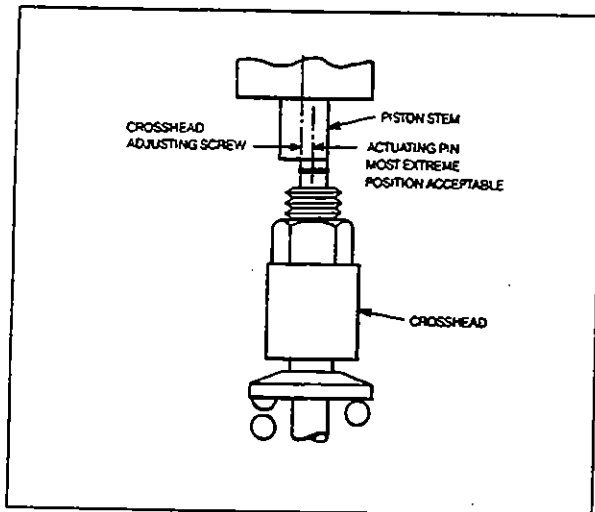

Fig. 1.4.11

### Check Ball Valve: Used in Models 401 and 404

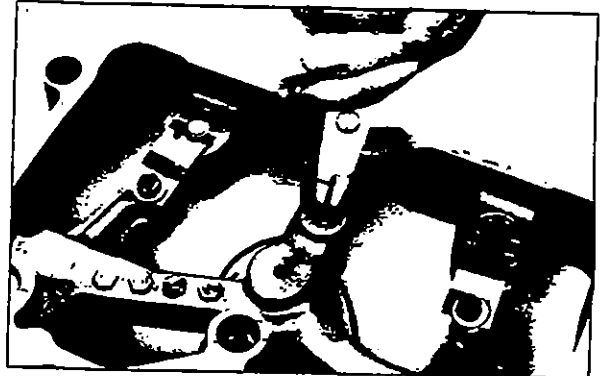

Fig. 1.4.12

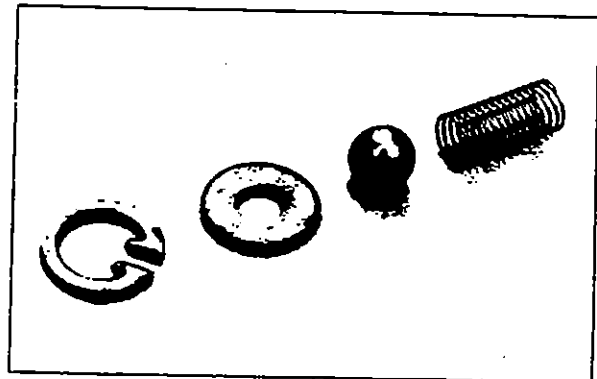

Fig. 1.4.13

The check ball mechanism in the single-valve engine brake is used to prevent the high-pressure oil that is passing through the slave piston drillings from leaving the engine brake housing. If the oil did escape from the housing, the normal engine oil supply would be insufficient to make up the loss of oil and the engine brake performance would be greatly reduced.

During reassembly, pay special attention to the proper sequence of reinstalled parts and make sure that the proper parts are used.

### Reset Mechanism: Used in Models 401 and 404

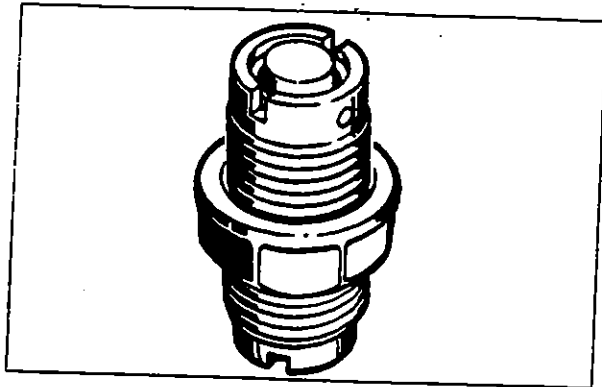

Fig. 1.4.14

The purpose of the reset mechanism is (1) to allow the opening of a single exhaust valve during engine brake operation; and (2) after the energy is released from the cylinder, to close the exhaust valve that was open before the normal exhaust rocker motion begins. This prevents excessive side loading on the engine's crosshead guide pin.

### Reset Design

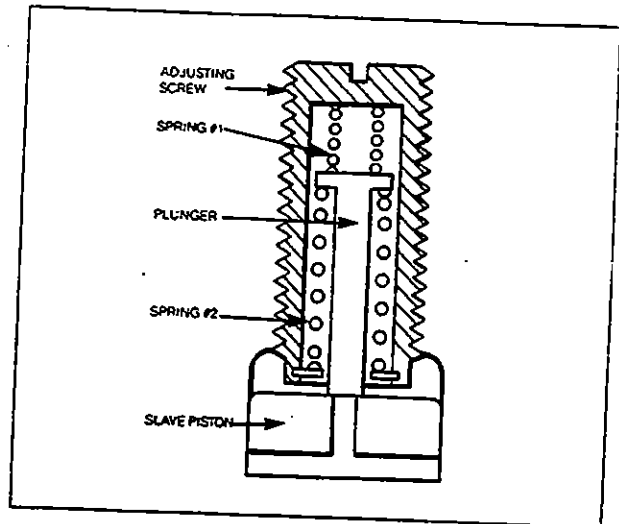

Fig. 1.4.15

The main components are the screw body, the plunger and two springs. Spring #1, on top of the plunger, holds the plunger lightly against the slave piston upper hold, preventing the oil from flowing out too early in the engine brake cycle. Spring #2 pops the plunger off the slave piston when the reset mechanism activates. This uncovers the upper slave piston hole and allows the oil to flow to the bottom of the control valve bore.

### Reset Operation

Initially, the top spring holds the reset plunger against the slave piston and covers a hole in the top of the slave piston. When the engine brake is activated and engine oil pressure moves the master piston down against the injector adjusting screw, the rocker upward motion starts building high hydraulic pressure in the engine brake high-pressure circuit. The slave piston moves down against the Jacobs crosshead pin assembly and the engine exhaust valve stem. The oil in the housing high-pressure circuit build pressure rapidly, producing the force required to open the exhaust valve.

Since the area above the reset plunger is greater than the area under it, the plunger is forced down with the slave piston, keeping the top hole sealed.

As the slave piston moves down on the exhaust valve stem, the reset plunger follows the slave piston and compresses Spring #2. At this time, the high oil pressure above the reset plunger is greater than pressure from Spring #2, and the plunger continues following the slave piston.

When the exhaust valve is opened and the compressed air leaves the cylinder, the high pressure in the housing drops rapidly. When the oil pressure drops below the force of Spring #2, the spring forces the plunger back into the screw body and the hole in the top of the slave piston is uncovered. The oil passes through the hole in the top of the slave piston, out through the crosshole and into the passage to the bottom of the control valve bore. Since this oil is still at a relatively high pressure, it moves the control valve upward. This reduces the pressure to nearly that of low-pressure supply oil.

With oil pressure reduced, the slave piston springs return the slave piston to the start position and the engine exhaust valve closes. The engine valve is closed before normal engine exhaust motion begins. The engine exhaust rocker pushes against the crosshead with both exhaust valves opening together.

The engine brake is now ready for another cycle.

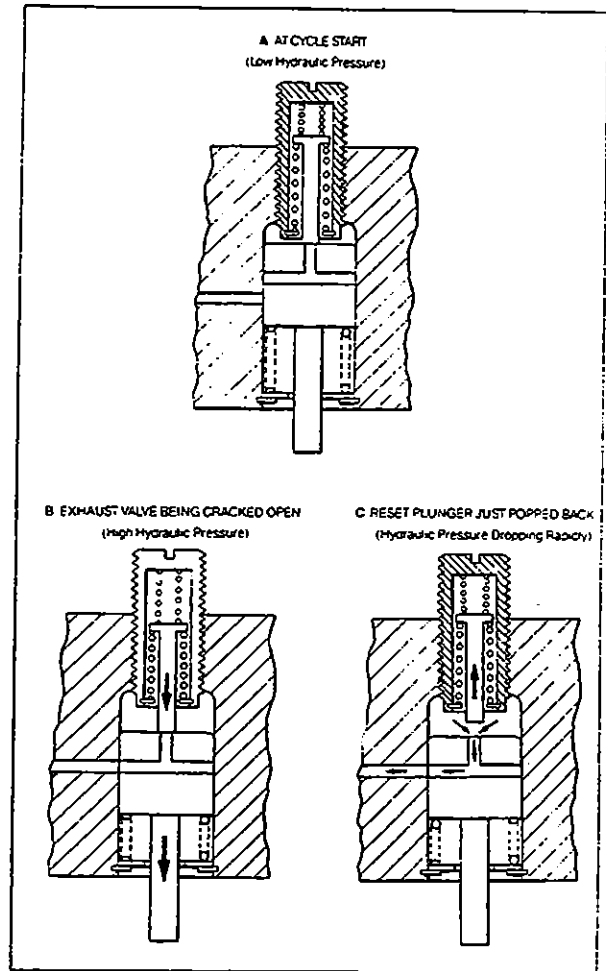

Fig. 1.4.16

### Short Slave Piston Part Numbers for Reworked Cylinder Heads and Exhaust Valves

	401	404/BG/C/D	404 - 404BG
Standard	009439	016774	011377
Short	012397	017260	012419

Short slave pistons may be required where cylinder heads and exhaust valves have been reworked. Valve stems may protrude too high above cylinder head to allow for sufficient clearance between slave piston and crosshead screw and pin assembly.

# NOTES



# 1.5 Engine Brakes for Caterpillar Engines

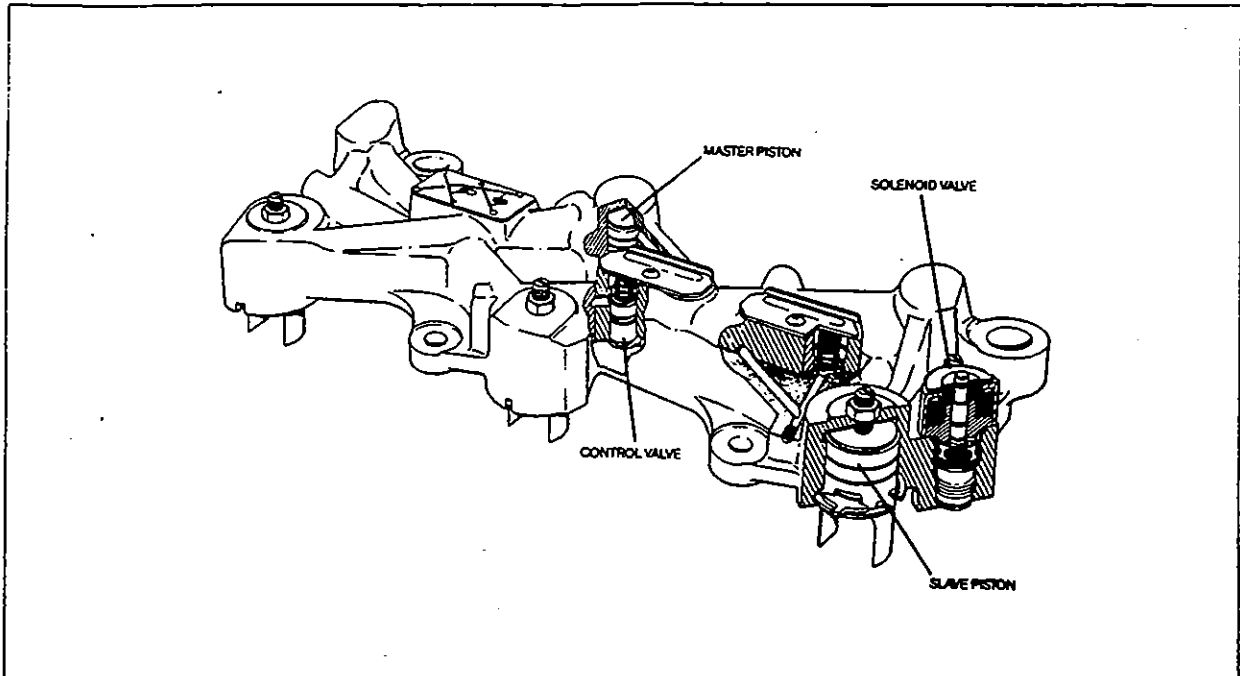

Fig. 1.5.1

## Caterpillar 3406/B/C Engines

### Master-Slave Circuit Relationship Listed in Engine Firing Order

Location of Master Piston	Location of Slave Piston
<b>Actuates</b>	
No. 1 Pushrod	No. 3 Exhaust Valve
No. 5 Pushrod	No. 6 Exhaust Valve
No. 3 Pushrod	No. 2 Exhaust Valve
No. 6 Pushrod	No. 4 Exhaust Valve
No. 2 Pushrod	No. 1 Exhaust Valve
No. 4 Pushrod	No. 5 Exhaust Valve

# Special Features

## Exhaust Rocker Adjusting Screw

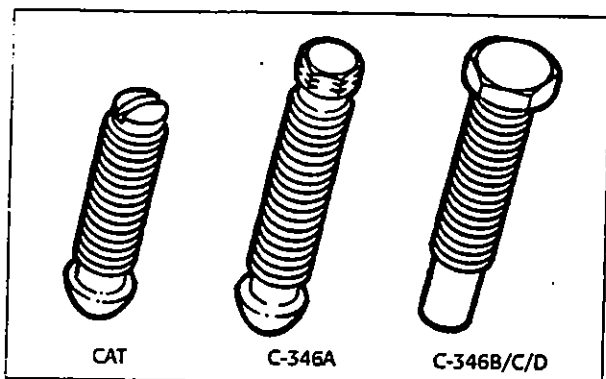

Fig. 1.5.2

The large headed screws can be used with C-346A and C-346 housings. If large-headed screws are used on C-346A and C-346 housings, Model C-346B/C/D master piston return springs must also be used. See parts manual for part numbers.

## Slave Piston Adjusting Screw

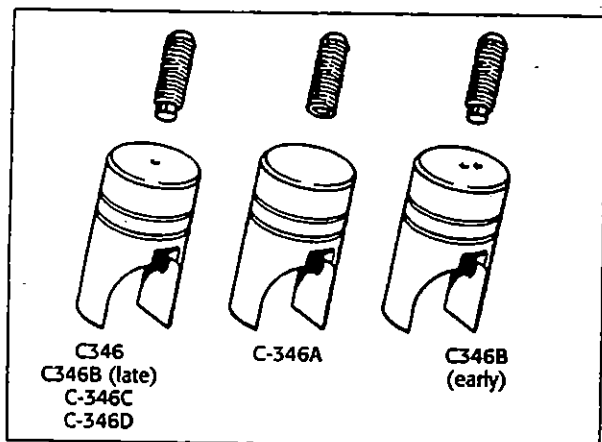

Fig. 1.5.3

The Models C-346B and C-346 use an adjusting screw with a spring loaded valve at the slave piston end. Note that the adjusting screws are different and have different part numbers and are not interchangeable. The adjusting screw valve seals the center hole in the slave piston during engine brake operation.

The piston used in the early production C-346B also has a 0.025-inch (0.64 mm) diameter bleed hole located to the side of the center hole.

The Model C-346A uses a solid adjusting screw and a solid slave piston (no hole through the top).

**NOTE:**

IT IS RECOMMENDED THAT C-346A HOUSING BE CONVERTED TO INCLUDE NEW ADJUSTING SCREWS AND SLAVE PISTONS. THESE PARTS ARE ONES CURRENTLY USED IN C-346D HOUSINGS.



SOLID ADJUSTING SCREWS MUST NOT BE USED IN MODEL C-346, C-346B, 346C AND 346D HOUSINGS BECAUSE THE HOLE IN THE TOP OF THE SLAVE PISTON WILL NOT BE SEALED AND ENGINE BRAKING WILL BE LOST. EXCESS OIL WILL BE SPILLED IN THE OVERHEAD.

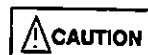

DO NOT READJUST OR TAMPER WITH THE ADJUSTING SCREW ASSEMBLY. ENGINE DAMAGE COULD RESULT.

**NOTE:**

FOR C-346B APPLICATIONS, A "B+ UPGRADE KIT" CAN BE INSTALLED TO IMPROVE RETARDING PERFORMANCE. SEE A JACOBS DISTRIBUTOR OR DEALER FOR DETAILS.

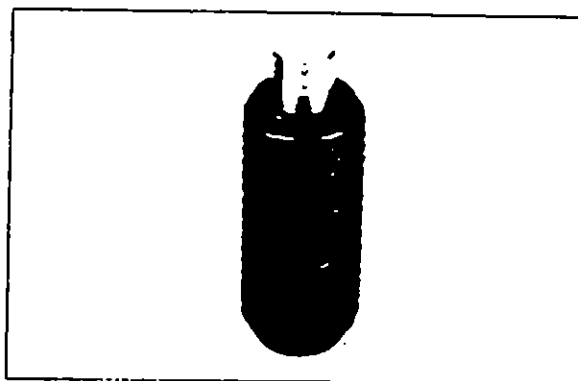

Fig. 1.5.4

# Model 349A Engine Brake

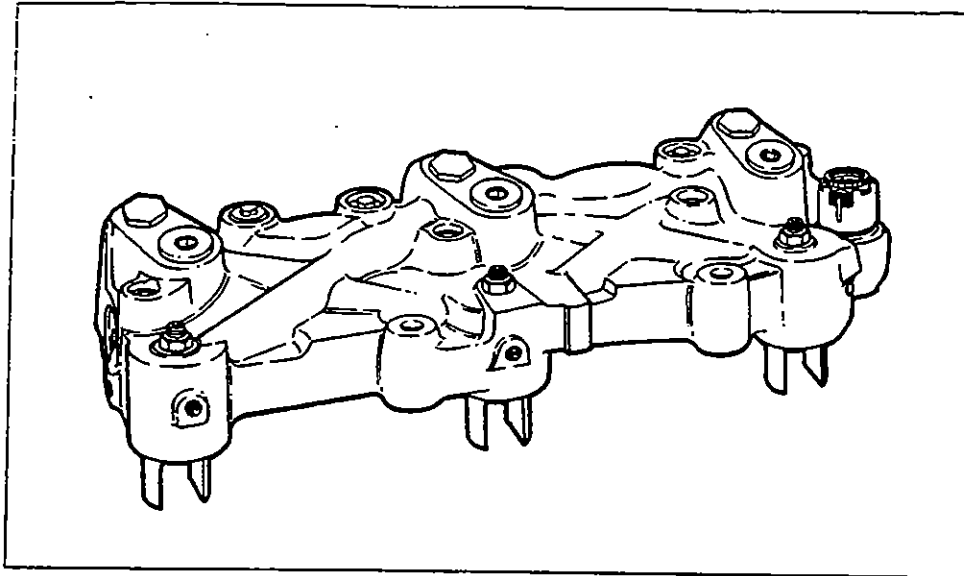

Fig. 1.5.5

The Model 349A Jake Brake Engine Retarder is designed and approved for use on Caterpillar 3406B ATAAC (Air-to-Air After-cooled) engines with PEEC or mechanical fuel controls. The Model 349A replaces the former Model 349.

**NOTE:**

THE MODEL 349A IS NOT TO BE INSTALLED ON 3406B ENGINES WITH SERIAL NUMBERS LOWER THAN 7FB39279 OR ANY 3406 ENGINES WITH THE 92U SERIAL NUMBER PREFIX.

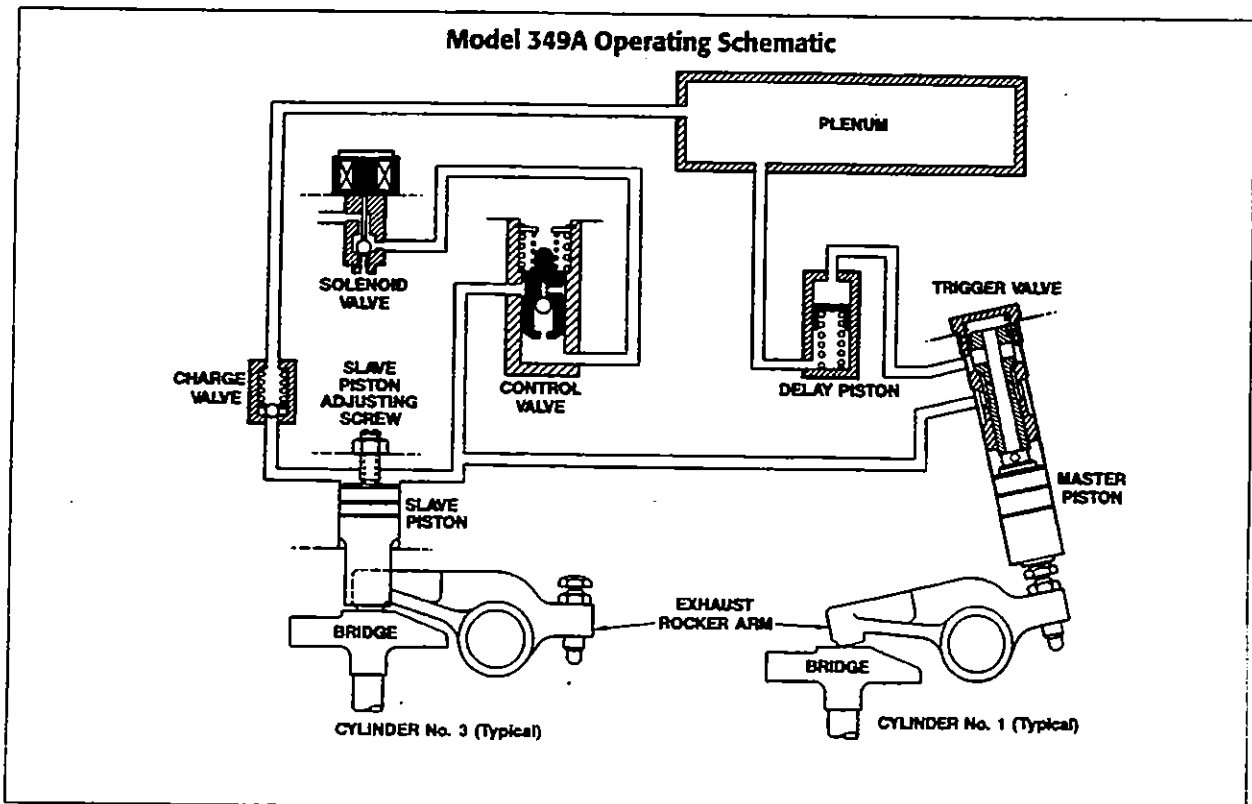

Fig. 1.5.6

## Master-Slave Circuit Relationship Listed in Engine Firing Order

Location of Master Piston	Location of Slave Piston
<b>Actuates</b>	
No. 1 Pushrod	No. 3 Exhaust Valve
No. 5 Pushrod	No. 6 Exhaust Valve
No. 3 Pushrod	No. 2 Exhaust Valve
No. 6 Pushrod	No. 4 Exhaust Valve
No. 2 Pushrod	No. 1 Exhaust Valve
No. 4 Pushrod	No. 5 Exhaust Valve

### Exhaust Blowdown

The braking cycle is accomplished by utilizing the pushrod motion of an exhaust valve of another cylinder during its normal exhaust cycle. Referring to the chart above, Cylinder No. 1 exhaust pushrod opens the exhaust valves of Cylinder No. 3 in this sequence:

1. The energized solenoid valve permits engine lube oil to flow under pressure through the control valve to both the master piston and the slave piston.
2. Oil pressure causes the master piston to move down, coming to rest on the corresponding exhaust rocker arm adjusting screw. See the accompanying chart for master/slave operation relationship.
3. The exhaust rocker pushrod begins upward travel (as in normal exhaust cycle) forcing the master piston upward and creating a high pressure oil flow to the delay piston.
4. The delay piston moves and compresses the plenum oil to high pressure. The delay piston and plenum act as a high pressure "spring" to activate the slave piston at the appropriate time.

5. The master piston moves upward and at the appropriate time, opens the trigger valve.
6. High pressure oil flows from the delay piston through the trigger valve to the slave piston.
7. The slave piston moves down, contacts the exhaust valve bridge and opens the exhaust valves releasing compressed cylinder air to the exhaust manifold.
8. Compressed air escapes to atmosphere, completing a compression braking cycle.

### Slave Piston Adjustment

For correct slave piston adjustment procedures and settings, refer to specific installation manual and current service publications.

### Trigger Valve Adjustment

**NOTE:**

**REMOVE TRIGGER CAPS AND SPRINGS FROM ALL CYLINDERS BEFORE ADJUSTING TRIGGER.**

Trigger valve travel adjustment is set according to the settings shown in the following chart:

#### Trigger Adjustment (inches)

Cylinder No.	Pre-1991 Model Year	Post 1990	
		1991 and later 400 HP	All Others
1	0.100	0.130	0.100
2, 3, 4, 5, 6	0.100	0.095	0.100

All adjustments are  $\pm 0.003$  inch

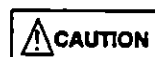

**CYLINDER NO. 1 TRIGGER VALVE SETTING ON 1991 MODEL YEAR ENGINES WITH 400 HP IS DIFFERENT THAN FOR THE OTHER CYLINDERS ON THAT ENGINE.**

**NOTE:**

**TRIGGER VALVE ADJUSTMENT AS WELL AS SLAVE PISTON ADJUSTMENT MUST BE MADE ANY TIME THE BRAKE HOUSINGS ARE REMOVED AND REPLACED.**

After the valves and slave pistons are adjusted on all cylinders, the trigger valves should be adjusted using the trigger adjusting group shown in Fig. 1.5.7.



MAKE THIS ADJUSTMENT CAREFULLY AND ACCURATELY TO ASSURE MAXIMUM ENGINE BRAKE PERFORMANCE AND TO PREVENT POSSIBLE ENGINE DAMAGE. THE JACOBS TRIGGER ADJUSTMENT GROUP IS REQUIRED FOR THIS ADJUSTMENT.

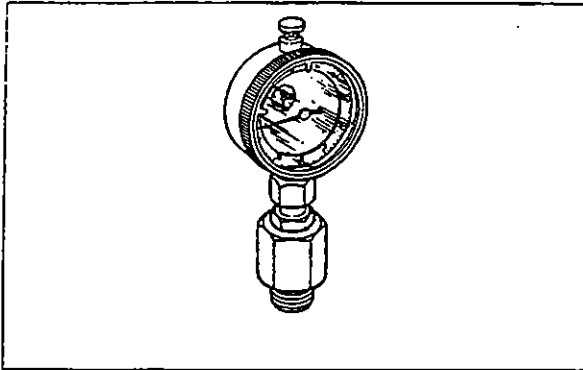

Fig. 1.5.7

1. Remove trigger caps and springs from ALL cylinders before adjusting the trigger. Do not remove trigger valve (see Fig. 1.5.8).

The first trigger adjustment should be made on the cylinder last adjusted for slave piston lash.



Fig. 1.5.8

2. Install the dial indicator assembly into the trigger valve bore (see Fig. 1.5.9). Hand tighten, metal to metal contact only.

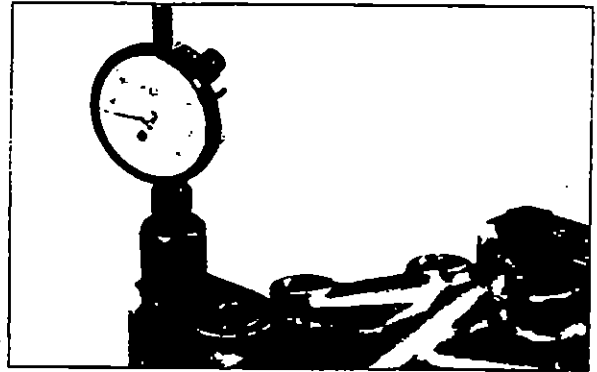

Fig. 1.5.9

Indicator extension will contact the trigger valve and push the master piston down slightly (see Fig. 1.5.10).

**NOTE:**

**THE MASTER PISTON MUST NOT COME IN CONTACT WITH THE EXHAUST ROCKER ADJUSTING SCREW AT THIS TIME.**

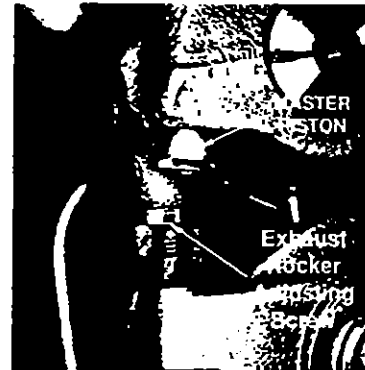

Fig. 1.5.10

3. Set the indicator to zero.
4. Rotate the engine crankshaft slowly in the direction of rotation. The exhaust rocker adjusting screw will contact the master piston and the dial indicator needle will begin to move. Record the maximum travel of the indicator.

**Travel must be set according to Trigger Adjustment Chart on page 1.5.4.**

5. Use the following procedure to adjust the trigger travel. The indicator travel must be within  $\pm 0.003$  inch of specific trigger adjustment as shown in the chart on page 1.5.4.

If necessary to further adjust trigger travel:

- A. Remove the dial indicator/adaptor assembly and insert a long 5/32-inch hex key wrench through the trigger valve bore and into the master piston assembly (see Fig.1.5.11).



Fig. 1.5.11

- B. Insert the Jacobs master piston holding wedge between the master piston and exhaust rocker adjusting screw. Push the wedge in until the master piston bottoms in its bore (see Fig. 1.5.12). This will prevent the master piston from turning while the trigger adjustment is being made.

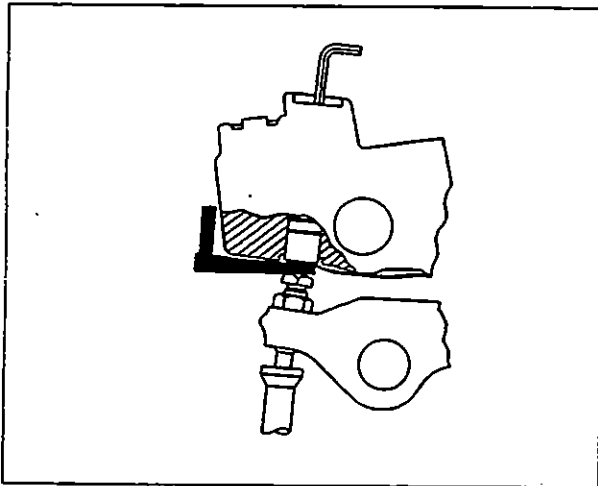

Fig. 1.5.12

- C. Push down on the hex key wrench. This unlocks the adjusting screw from the hex pin (see Figs. 1.5.13 and 1.5.14).

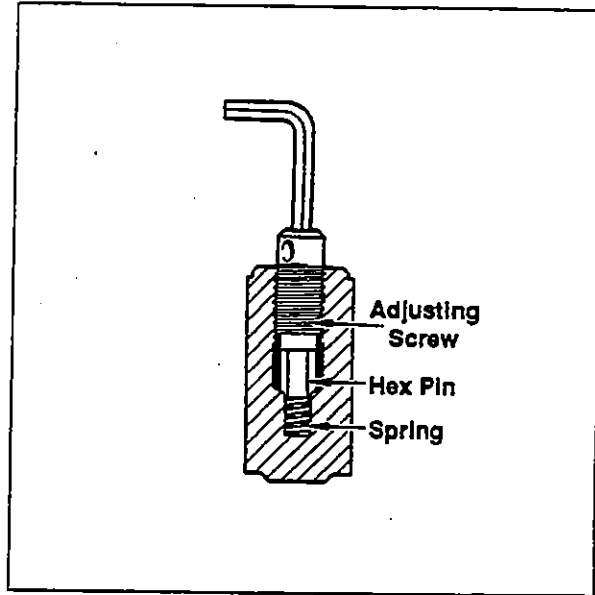

Fig. 1.5.13

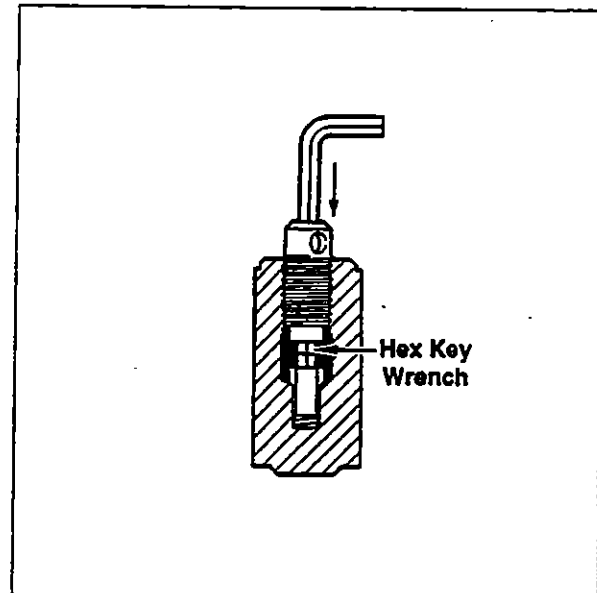

Fig. 1.5.14

- D. Refer to the original recorded travel found in Step 4 on previous page and adjust by pressing hex key wrench against spring pressure. Maintain pressure while turning clockwise to decrease travel or counterclockwise to increase travel. Each hex (60 degrees) equals approximately 0.005-inch trigger travel.
- E. Remove hex key wrench. Adjusting screw must be locked.

**NOTE:**

SPRING PRESSURE ON THE HEX PIN SHOULD LOCK THE ADJUSTING SCREW IN POSITION WHEN PRESSURE ON THE HEX KEY WRENCH IS REMOVED. IF ADJUSTING SCREW IS NOT LOCKED (SCREW CAN TURN), ROTATE SCREW SLIGHTLY UNTIL HEX PIN SNAPS INTO ADJUSTING SCREW. SCREW IS NOW LOCKED IN POSITION.

Reinstall dial indicator assembly. Re-check travel by rotating engine crankshaft back and forth. Repeat setting procedure, if necessary.

- F. Replace trigger spring and cap. Tighten cap to 35 lbf. (47 N•m).
- G. Continue adjustment of remaining cylinders in the engine firing order. Re-check torque on all six trigger caps.

---

## Models C317, C317A, 317B and 317C Engine Brakes

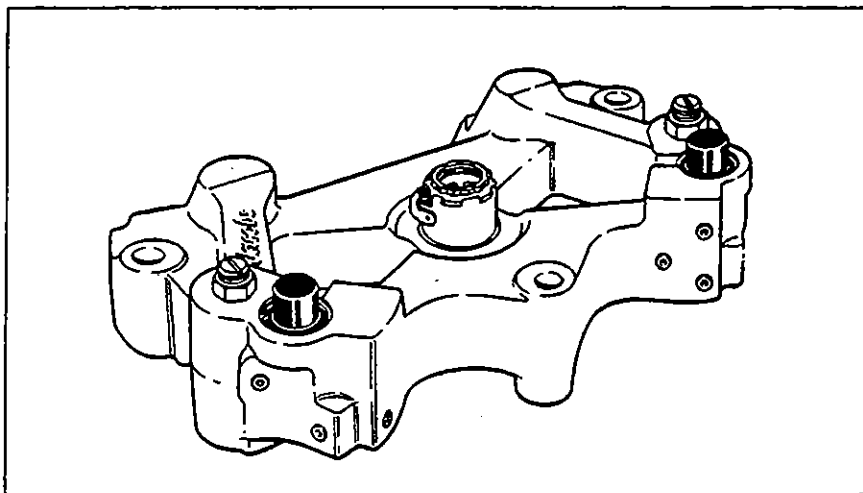

Fig. 1.5.15

## Power-Lash™

To ensure optimum exhaust valve opening during engine brake operation, a Power-Lash assembly is incorporated in the slave piston adjusting screw.

- A. The hole in the slave piston is sealed by a plunger in the Power-Lash. A spring holds the plunger extended for the desired travel of the slave piston (Fig. A).
- B. When the desired travel of the slave piston and exhaust valve opening is achieved, the hole is uncovered and the high pressure oil escapes to the area below the control valve (Fig. B).
- C. The control valve moves up, compressing the stop (large) spring, providing a small volume of "stored" oil, ready for the next engine brake cycle. The reduced oil pressure allows the slave piston to return to its starting position, against the slave piston screw (Fig. C).

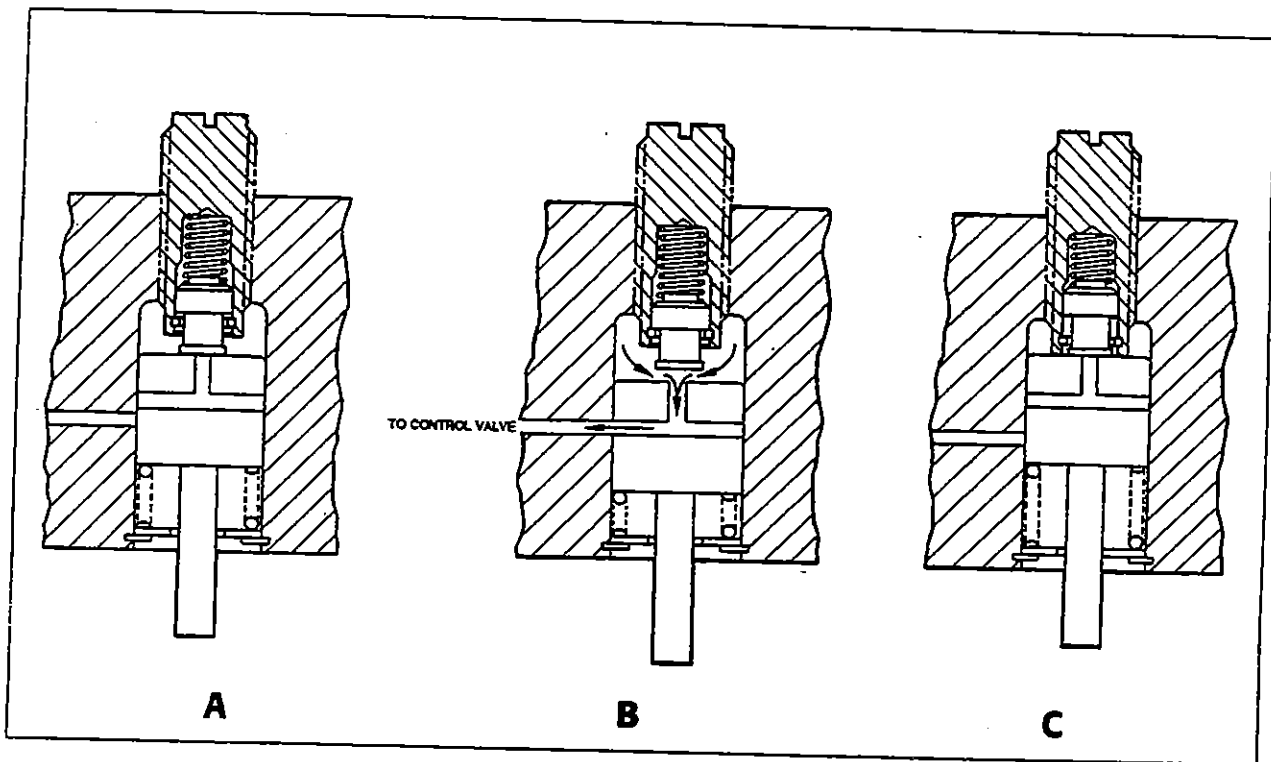

Fig. 1.5.16



The Model 317B Jake Brake engine retarder has been designed and approved for use on 1991 and pre-1991 model year 3176 Caterpillar engine and replaces the Models C317 and C317A as the production model.

The Model 317C is designed and approved for use on 1992 model year 3176C Caterpillar engines with serial numbers 7LG7500 and higher.

Mounting methods for the C317A and C317 housings are different because of the height difference shown in Figs. 1.5.17 and 1.5.18. See brake housing installation section for specific installation procedures.

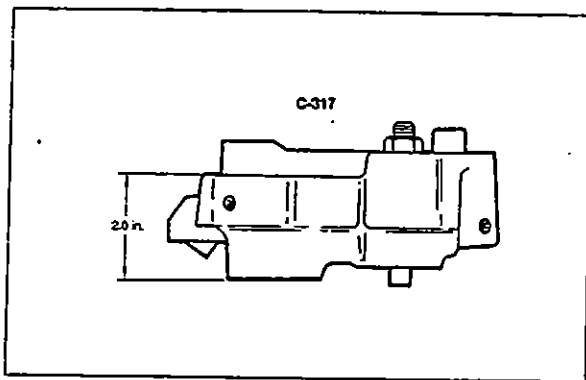

Fig. 1.5.17

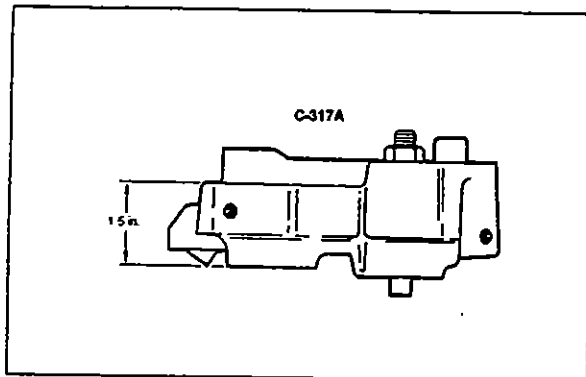

Fig. 1.5.18

## Housing Assembly Differences

### Models C317/C317A

The clip valve, P/N 014811, and Power-Lash, P/N 018168A, originally used for the C317 and C317A housings have been superseded by Power-Lash, P/N 018168B. Use only Power-Lash, P/N 018168B, for replacement parts. Part numbers are located on the top of the screw body.

### Models 317B/317C

The Power-Lash part number for Model 317B is 018168B. The Power-Lash part number for Model 317C is 018422.

The master piston assembly for 317B and 317C is shown in Fig. 1.5.19. Master piston assembly for Models C317 and C317A is shown in Fig. 1.5.20. Master pistons and housings are not interchangeable.

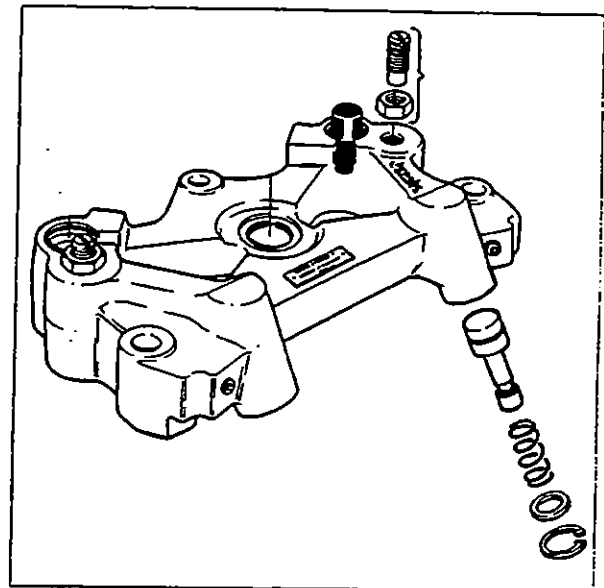

Fig. 1.5.19

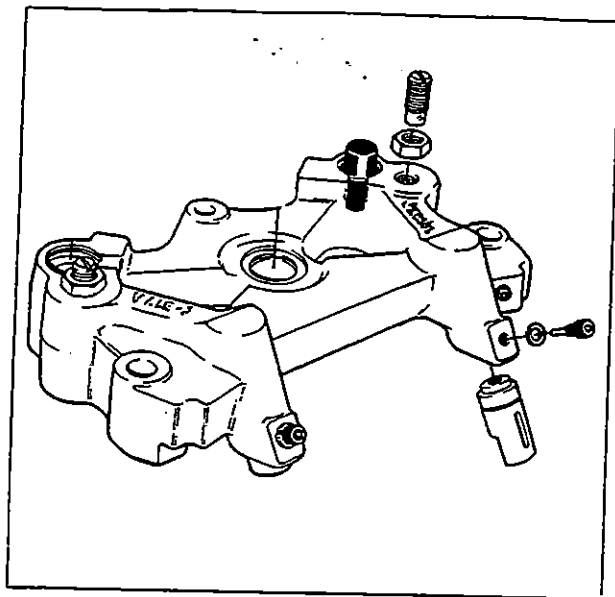

Fig. 1.5.20

**Model C317 Only**

**NOTE:**

**THE FOLLOWING SIX STEPS APPLY TO MODEL C317 HOUSINGS ONLY AND NOT TO THE C317A.**

Extended stud, P/N 016088, has been replaced by bolt, P/N 014800. It is recommended when servicing or installing the C317 engine brake, the extended stud, P/N 016088, be replaced by bolt, P/N 014800. Use the following procedure for C317 housing installation.

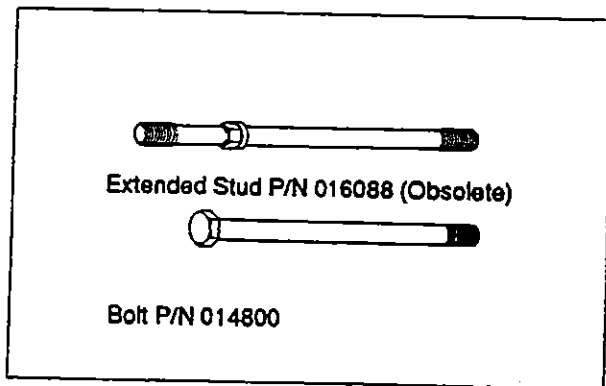

Fig. 1.5.21

**NOTE:**

**TO ADJUST THE INJECTORS AND VALVES, THE ENGINE BRAKE HOUSINGS MUST BE REMOVED AND THE ROCKER ASSEMBLY SECURED WITH CATERPILLAR ROCKER PEDESTAL CAPSCREWS OR JACOBS P/N 014800 CAPSCREW WITH 2-INCH SPACES, JACOBS P/N 017535. TORQUE TO 70 LBFT. (9 N·M).**

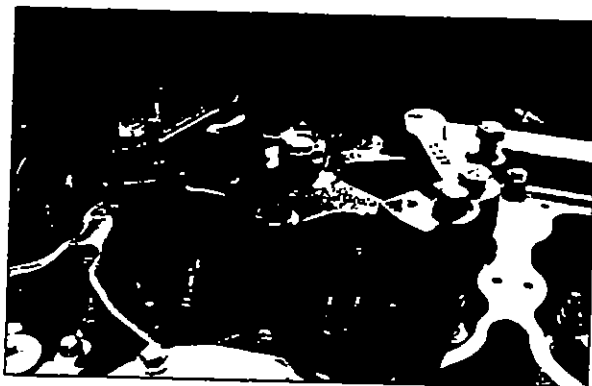

Fig. 1.5.22

1. After injectors and valves have been adjusted, remove the extended studs, or for new installations, remove the Caterpillar rocker pedestal capscrows.
2. Install the engine brake housing on the rocker pedestals.
3. Install the Jacobs bolt P/N 014800 (2 per housing) into the housing and rocker pedestals.
4. Install the Jacobs bolt through the housing into the spacer on the cylinder head bolt.
5. Tighten bolt at the rocker pedestals to 70 lbft. (95 N·m).
6. Tighten the bolt at the head bolt spacer to 41 lbft. (55 N·m).

**For Models C317A/317B/317C**

Install the mounting stud assemblies in the rocker brackets and torque to 70 lbft. (95 N·m). Adjust the injectors and valves per Caterpillar specifications.

Adjust the engine brake slave piston clearance with the valves closed to the clearance shown below:

**Slave Piston Adjustment**

For correct slave piston adjustment procedures and settings, refer to specific installation manual and current service publications.

# Model C336 and 336A Engine Brakes

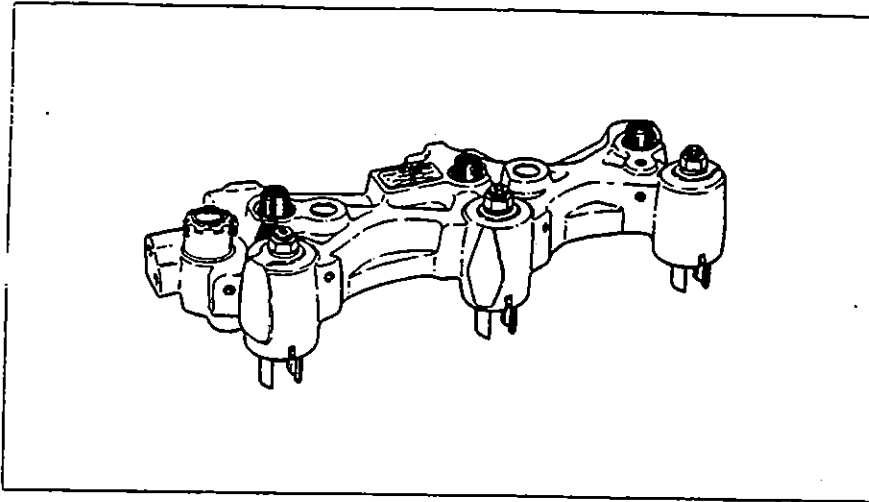

Fig. 1.5.23

The Model C336 Jake Brake Engine Brake is approved for use on Caterpillar 3306B engines with serial numbers greater than 63Z3300 and 3306 engines with serial numbers greater than 76R6115.

The Model 336A Jake Brake Engine Brake is approved for use on Caterpillar 3306C engines with serial number 7RJ00116 or greater only.

## Master-Slave Circuit Relationship Listed in Engine Firing Order

Location of Master Piston	Location of Slave Piston
<b>Actuates</b>	
No. 1 Pushrod	No. 3 Exhaust Valve
No. 5 Pushrod	No. 6 Exhaust Valve
No. 3 Pushrod	No. 2 Exhaust Valve
No. 6 Pushrod	No. 4 Exhaust Valve
No. 2 Pushrod	No. 1 Exhaust Valve
No. 4 Pushrod	No. 5 Exhaust Valve

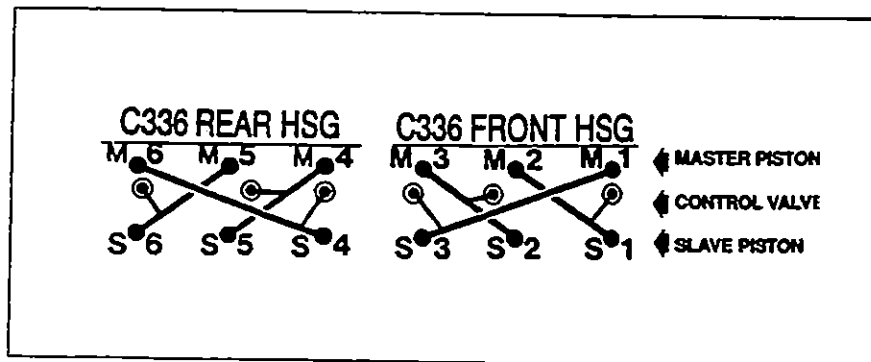

Fig. 1.5.24

## Exhaust Valve Stem Caps

The valve cap shown in Fig. 1.5.25 is currently used for Models C336 and 336A engine brakes. It can be used as a replacement part, when necessary, for the former cap used with the Model C336. The valve cap shown in Fig. 1.5.26 was previously used in the Model C336 engine brake

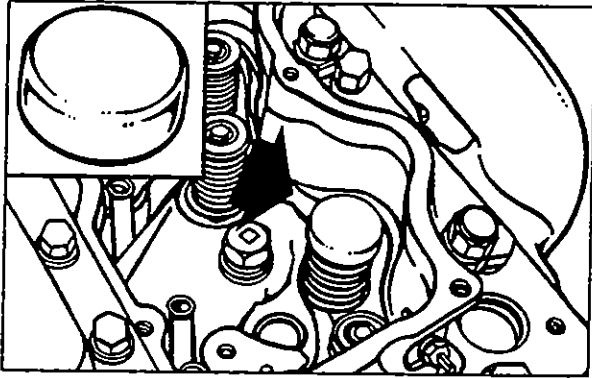

Fig. 1.5.25

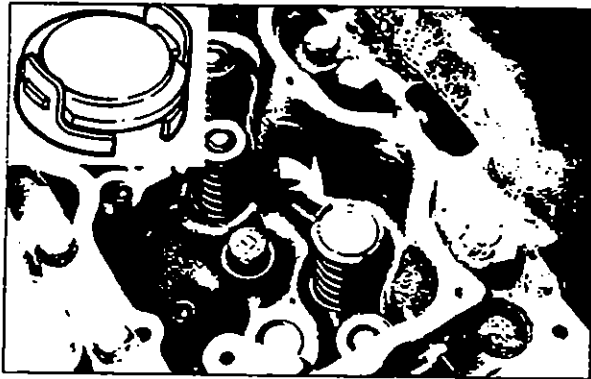

Fig. 1.5.26



**THE VALVE CAP SHOWN IN FIG. 1.5.26 MUST NOT BE USED IN MODEL 336A ENGINE BRAKES. SERIOUS ENGINE DAMAGE MAY RESULT.**

## Slave Piston Clearance Settings

**Model C336 only:**

The C336 uses the adjusting gauge shown in Fig. 1.5.27. See Installation Manual and current service publications for slave piston clearance setting.

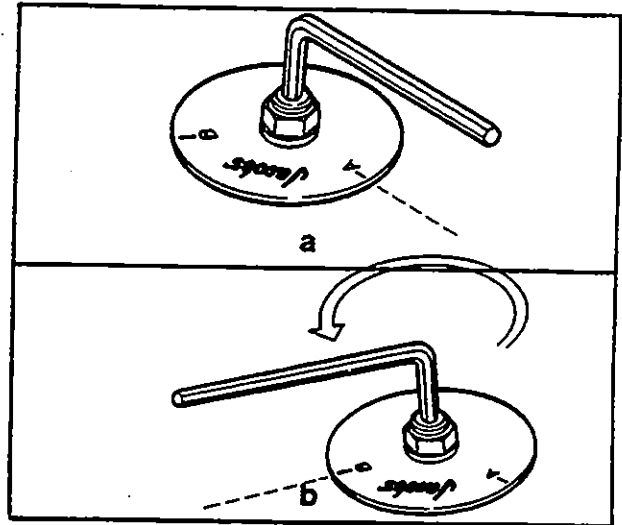

Fig. 1.5.27

**Model 336A only:**

Place the Jacobs lash adjusting gauge (slave piston adjustment 0.135 inch), P/N 018989, between the valve cap and slave piston foot (see Fig. 1.5.28).



**BE SURE THAT THE FEELER GAUGE IS FULLY ENGAGED UNDER BOTH SLAVE PISTON FEET (SEE FIG. 1.5.29). FAILURE TO PROPERLY USE TOOL MAY LEAD TO POOR PERFORMANCE AND/OR ENGINE/ENGINE BRAKE DAMAGE.**

Turn the adjusting screw, P/N 014351, clockwise until a slight drag is detected. Hold screw in this position and tighten locknut to 25 lbft. (35 N·m).

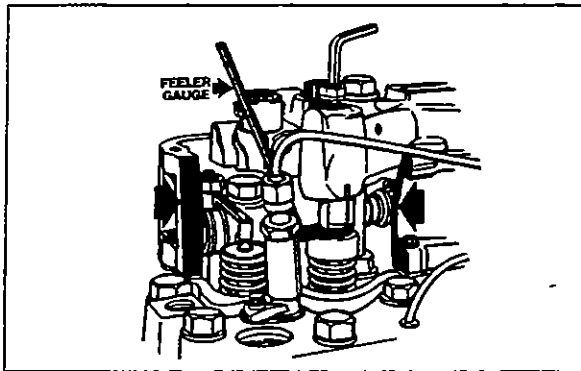

Fig. 1.5.28

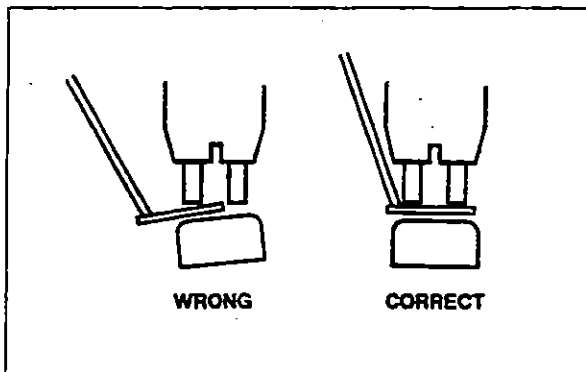

Fig. 1.5.29

The current mounting stud used with Model C336 and 336A housings is P/N 017156 (see Fig. 1.5.30). Bolt, P/N 016895, and spacer, P/N 012804, was previously used with the Model C336. P/N 016895 and 012804 are available as service parts.

Stud, P/N 016809, formerly used with the Model C336, has been superseded by stud, P/N 017156.

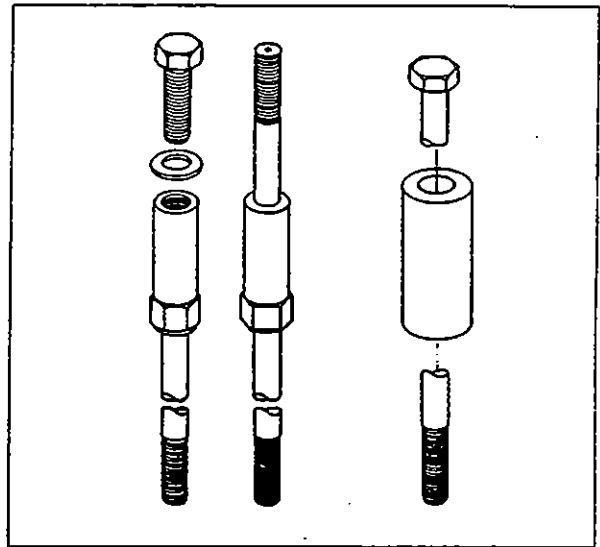

Fig. 1.5.30

## NOTES

# 1.6 Engine Brakes for Detroit Diesel Engines

## General Application Information

- 71A/92A (Fig. 1.6.1): Used on all 4, 6, 8, 12 and 16 cylinder engines whether naturally aspirated, turbocharged, TA or TTA engines

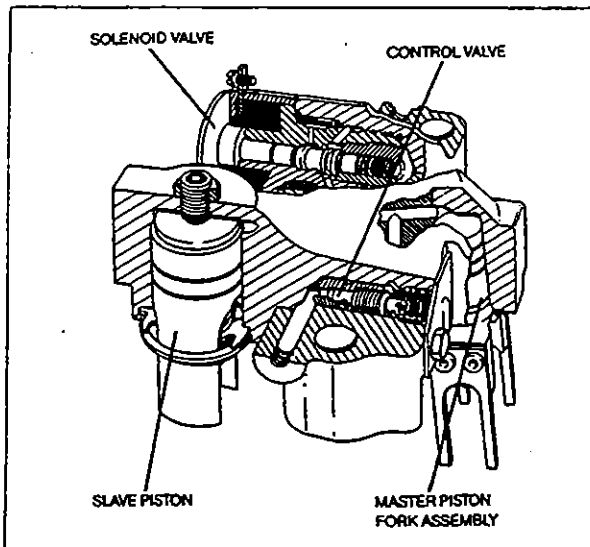

Fig. 1.6.1

- 53A (Fig. 1.6.2): Used on the following Detroit Diesel Engine Models: 3-53, 4-53, 6V-53, 8V-53

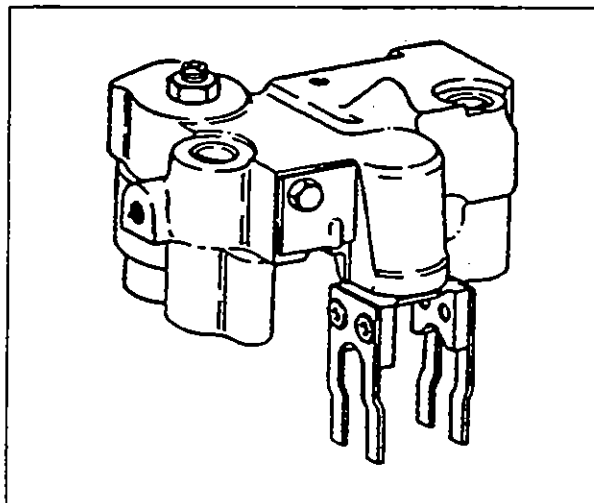

Fig. 1.6.2

## Adjustment of Engine Brake Slave Pistons

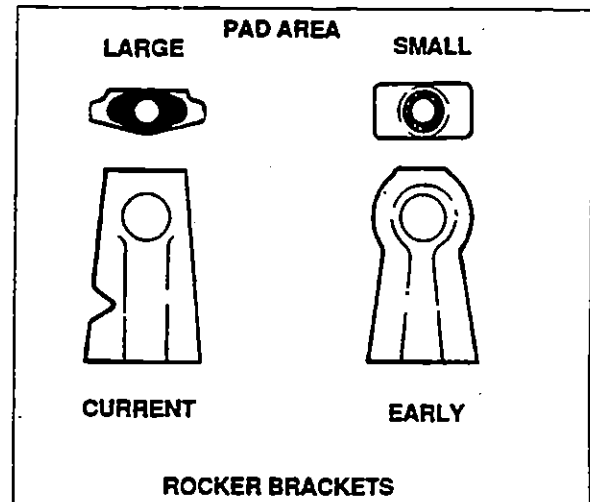
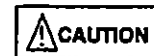

Fig. 1.6.3



Follow engine brake adjustment procedures carefully to prevent engine damage by piston to valve contact. Before making slave piston adjustments, make sure exhaust valves are closed and injector is in the delivery position.

## Slave Piston Settings Mod. 71/92A

Slave piston clearance must be set according to type of housing and rocker brackets. See Fig. 1.6.3. Refer to the following chart:

Housing/Bracket Type	Slave Piston Setting
Rocker Brackets with large pad area and 71A/92A engine brake housings	0.059 inch
All other combinations of brackets and housings	0.064 inch

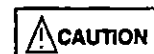

Do not use the 0.059 inch setting with the former Detroit Diesel rocker brackets or with the earlier Model 71/92 engine brake. Engine or engine brake failures will result. Those applications must continue to use the 0.064 inch slave piston setting.

## Slave Piston Adjustment: Model 53A

The Model 53A slave piston adjustment is done by a turns method. See the Model 53A Installation Manual for procedures.

## Special Features/Procedures

### Exhaust Valve Bridges

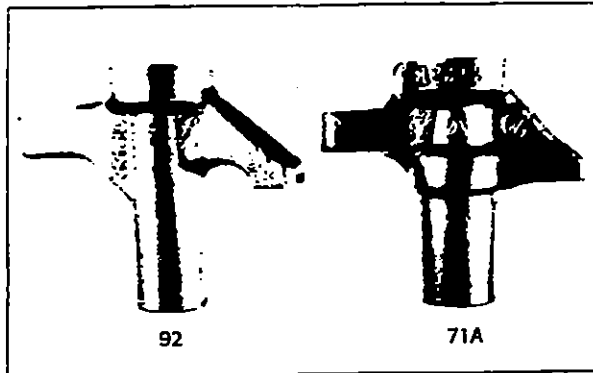

Fig. 1.6.4

The differences in the profile shape and the distance between valve stem contact points for Models 71A and 92A engine brake bridges can be seen in Fig. 1.6.4. Models 71A and 92A engine brake kits are identical except for bridge differences.

### DDEC Fuel Pipes

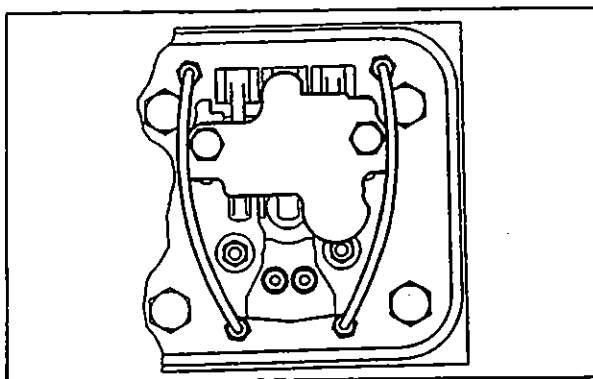

Fig. 1.6.5

DDEC fuel pipes (Fig. 1.6.5) must be removed prior to engine brake housing removal. Check fuel pipes for damage especially at the fitting area and replace if necessary. Fuel pipes may be reused if in good condition.

### Fuel Pipes - Non DDEC Engines

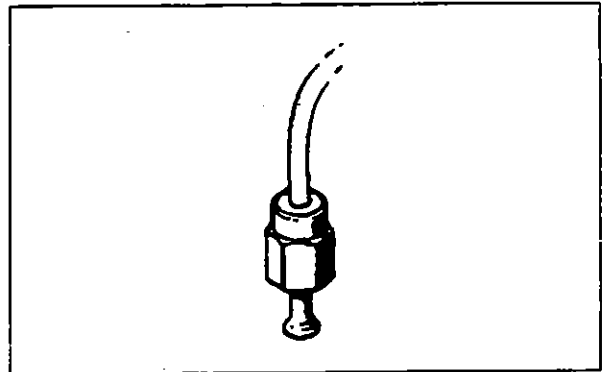

Fig. 1.6.6

The former flare type fuel pipes (Fig. 1.6.6) are not reusable. New O-ring style fuel pipes with attaching parts, must be installed in place of the flare type fuel pipes.

## Fuel Pipe Installation

### NOTE:

It is necessary to remove injectors which have been operated in an engine before replacing filter caps.

### Non-DDEC Engines

Replace flare style fuel pipes with O-ring style fuel pipes. In the following instructions, numbers in parentheses refer to Fig. 1.6.7 and Fig. 1.6.8.

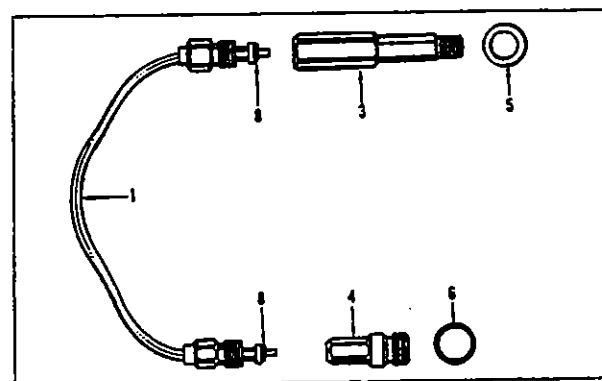

Fig. 1.6.7



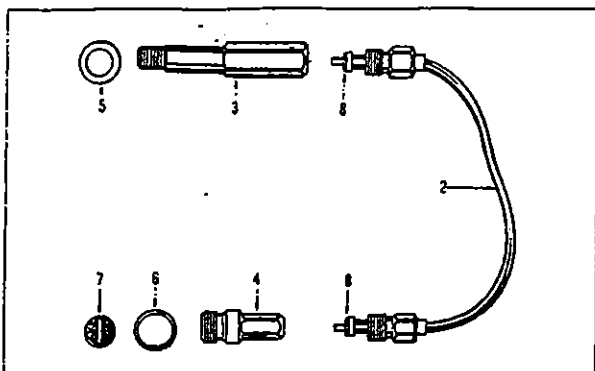

Fig. 1.6.8

1. Remove injectors according to instructions in the DDC engine service manual. Remove fuel connectors from cylinder head.



Fig. 1.6.9

2. Install the new connectors (3) with washers (5) into the cylinder head (2 per cylinder). See Fig. 1.6.9. Torque the connectors to 40 - 45 lbft. (54 - 61 N•m).
3. Remove injector filter caps, washers, gaskets/fuel inlet filters.
4. Install the new filter (7) into the inlet port of the injector, grooved side up. The injector inlet port is located above the control rack. See Fig. 1.6.10.

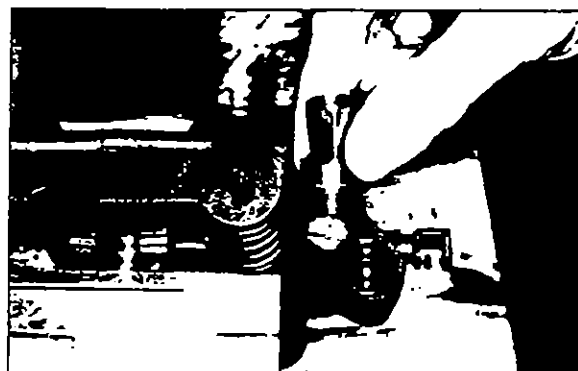

Fig. 1.6.10

5. Install the new fuel injector caps (4) and gaskets (6) into the inlet and return ports of the injector. Torque the caps to 60 - 70 lbft. (82 - 95 N•m). Use a deep well socket and torque wrench.
6. Install and adjust the fuel injectors according to instructions in the DDC engine service manual.
7. Remove the protective caps from the fuel pipes.

**NOTE:**

The O-rings (8) must be installed on the fuel pipes.

8. Lubricate the O-rings with clean lube oil and install the short (inlet) (2) and long (return) (1) fuel pipes.

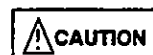

Set the pipe ends into the fittings. Hand tighten the fuel pipe nuts. Do not bend fuel pipes. See Fig 1.6.11. If the connections do not fit easily into the fittings or, if there is interference with the engine brake housing, replace the fuel pipes. Bending the fuel pipes may result in fuel leakage and severe engine damage.



Fig. 1.6.11

- Torque the fuel pipe nuts to 160 - 200 lbin. (18 - 23 N·m) using a fuel pipe nut socket and torque wrench.

### Fast Idle Buffer Switch

This type of switch is installed to retain the fast idle feature and automatic engine brake operation.

Follow the standard buffer screw plunger and switch assembly installation.

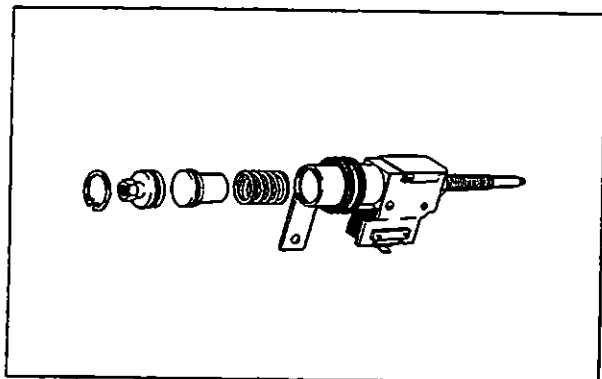

Fig. 1.6.12

- Attach the fast idle switch assembly to the buffer screw attaching nut.
- Adjust the switch bracket clamp to line up with the Detroit Diesel housing-to-blower bolt (Fig. 1.6.13).
- Remove the bolt and washer and secure the switch by placing the mounting bracket between the washer and bolt.
- Tighten the bolt and clamp.
- Install the air tube elbow into the inlet plug and attach the air tube between the elbow and the fast idle limiting air cylinder on top of the governor housing.

With the fast idle buffer switch properly installed, the engine brake will operate only during deceleration and will automatically shut off when fast idle activation occurs.

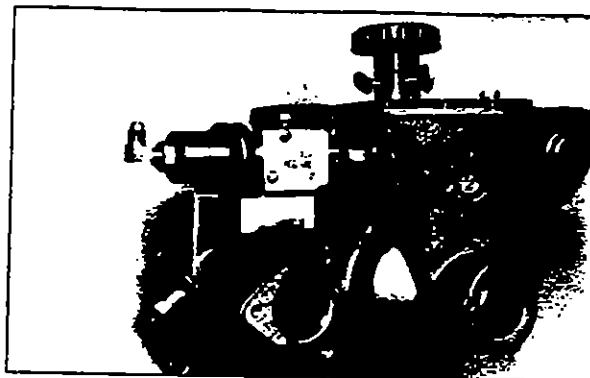

Fig. 1.6.13

### Oil Connectors

Poor performance problems may be caused by improperly installed or broken oil connectors. Pay particular attention to this area during troubleshooting.

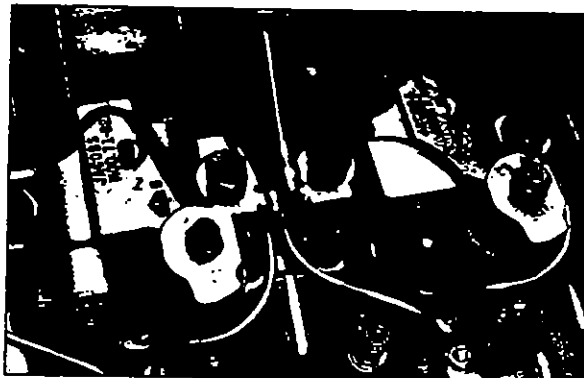

Fig. 1.6.14

- Reposition the seal ring in the head of the oil connector to make sure it fits into the recessed hex head of the connector screw (Fig. 1.6.14).
- Screw out the oil connector until metal-to-metal contact is made with the adjacent housing.
- Then, back off one-third of a turn, or two flats of the hex. Backing off is necessary to provide for movement of rocker and brake assemblies.

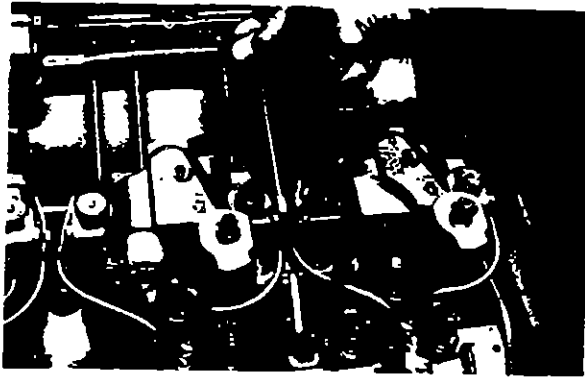

Fig. 1.6.15

4. Hold the oil connector in this position and carefully lock the lock nut. Use two short open end wrenches (Fig. 1.6.15). Remember, too much torque on these connectors will cause them to crack.

#### Clevis for Injector Rocker Lever

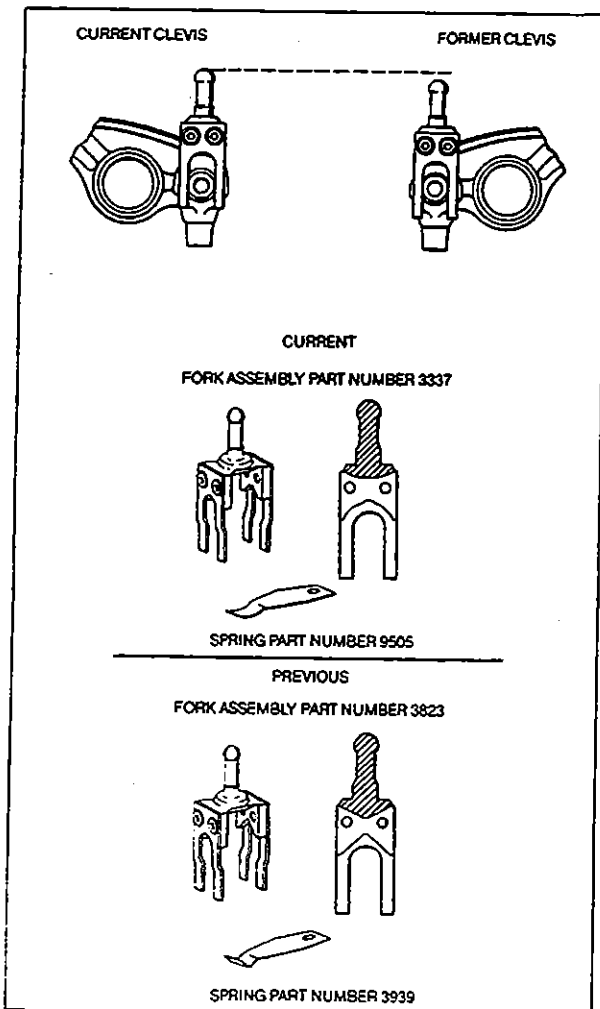

Fig. 1.6.16

In 1978, Detroit Diesel began using a larger clevis for the injector rocker lever. This clevis and the standard Jacobs fork assembly made an overall height greater than acceptable. Interference with the bottom of the engine brake housing could be damaging and an engine brake power loss could result.

When installing an older engine brake on a new engine or using older spare parts, special attention must be given in this area. The current fork assembly, P/N 003337, and spring, P/N 009505, can be used on both the high and standard clevises. It is **strongly recommended** that old housings be updated to the P/N 003337 fork and P/N 009505 spring combination.

## Two-Valve Head

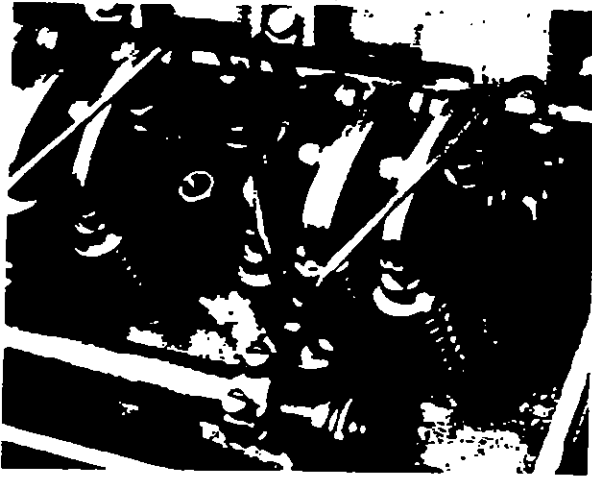

Fig. 1.6.17

Detroit Diesel also makes a two-valve cylinder head design. For this design, the Jacobs exhaust bridge is replaced with a Jacobs valve stem cap.

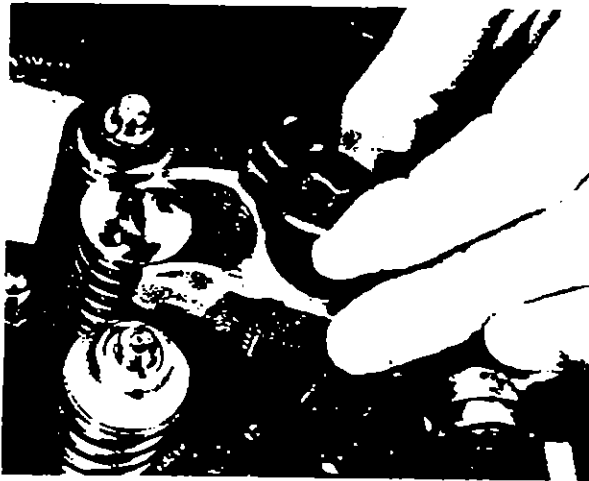

Fig. 1.6.18

1. On engines equipped with high mount injector clamps, remove the clamp by removing the bolt and special washer. Replace with a Jacobs high mount clamp and use the same washer and bolt (Fig. 1.6.18). Tighten the bolt to 25 lbft. (35 N•m). The Jacobs clamp can be identified by a small milled section on one side. This provides clearance for the exhaust valve stem cap.

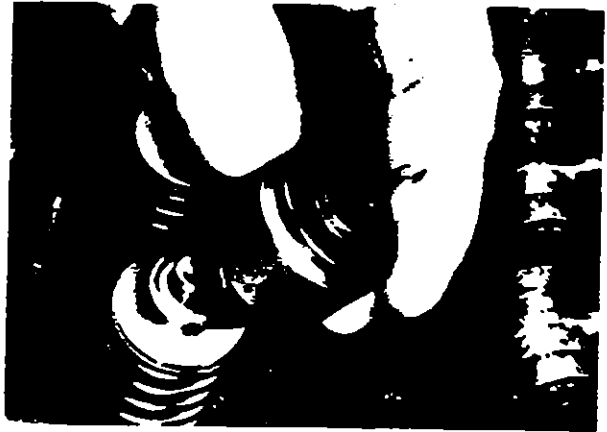

Fig. 1.6.19

2. Install Jacobs valve stem caps on right-hand exhaust valves (one per cylinder) (Fig. 1.6.19). Press caps firmly over valve springs. Hexagon cover studs must be removed if located near this valve.

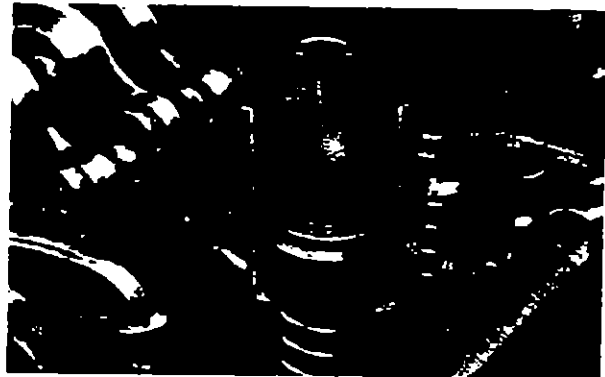

Fig. 1.6.20

3. Using the Jacobs clamping tool, back off the thumb screw. Install the tool squarely over the valve stem cap with its feet under the exposed coil of the valve spring (Fig. 1.6.20). Tighten the thumb screw to seat the cap. Remove the tool.

# Models 760/760A/765 Engine Brakes

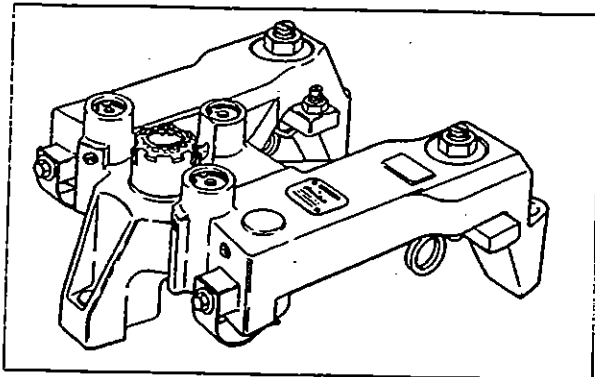

Fig. 1.6.21

## Engine Identification

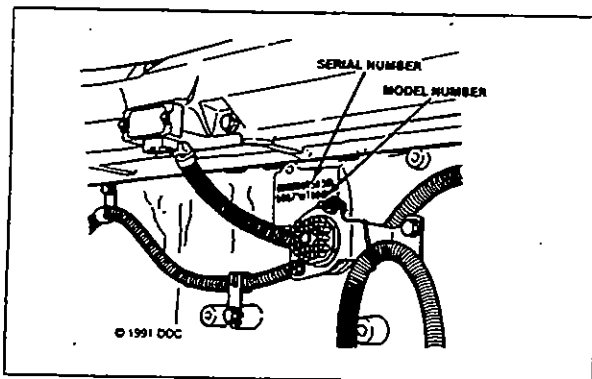
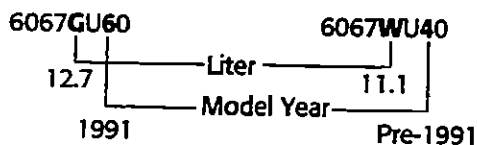

Fig. 1.6.22

Engine model identification is on the name tag located on the side of the valve cover and stamped on the cylinder block beneath the intake manifold. A "G" in the model number indicates 12.7 liter displacement; a "W" indicates 11.1 liter displacement. A "4" indicates pre-1991 model year; a "6" indicates 1991 model year. See typical number below:



## Slave Piston Adjustment

Models 760/760A/765 require a single-blade feeler gauge for slave piston adjustment. For correct adjustment procedures, clearance settings and feeler gauge part numbers, see Jacobs installation and parts manuals and service publications.

## Housing Mounting Bolts

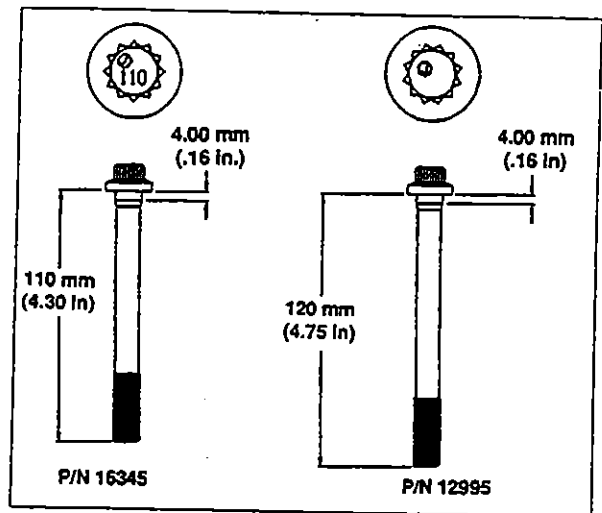

Fig. 1.6.23

### CAUTION

It is imperative that the correct Jacobs bolts be used for the engine brake housing being installed. Installation of incorrect bolts will result in engine and engine brake damage.

Model 760: Use one P/N 012995 (120 mm) bolt and two P/N 016345 (110 mm) bolts for each housing.

Models 760A and 765: Use three P/N 016345 (110 mm) bolts for each housing.

Follow the instructions in the Installation Manual, P/N 014328, for correct application and torque information.

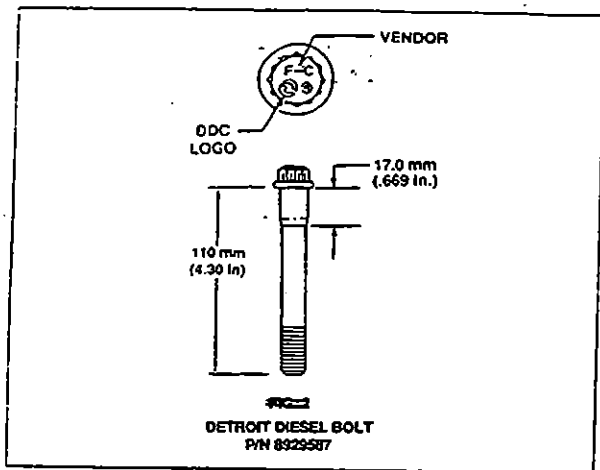

Fig. 1.6.24

The Detroit Diesel rocker arm shaft bolt used on Series 60 engines has a shoulder that is much longer than the Jacobs bolt and has the logo (spinning arrows) and vendor ID (F-C) on its head (Fig. 1.6.24). This bolt **MUST NOT** be used for the engine brake housing hold down.



If the Detroit Diesel bolt is mistakenly used for engine brake hold down, the longer shoulder on the bolt will restrict oil supply to the housing and prevent proper brake operation.

### Ball Check Valve - Model 760 Only

Remove the plug to remove the ball check valve and spring. Inspect parts for wear or damage and replace, if necessary. Reinstall the parts in the proper sequence. See Fig. 1.6.25.

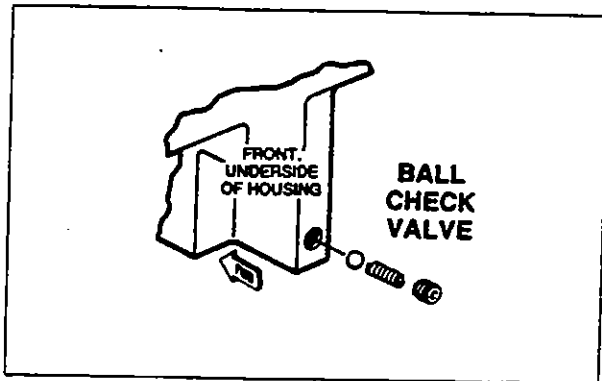

Fig. 1.6.25

## 1.7 Engine Brakes for Mack Engines

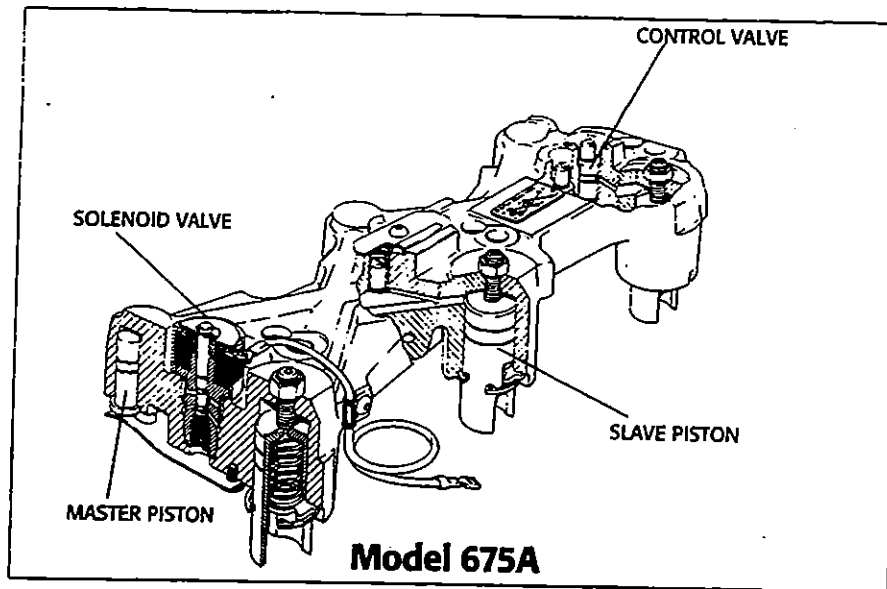

Fig. 1.7.1

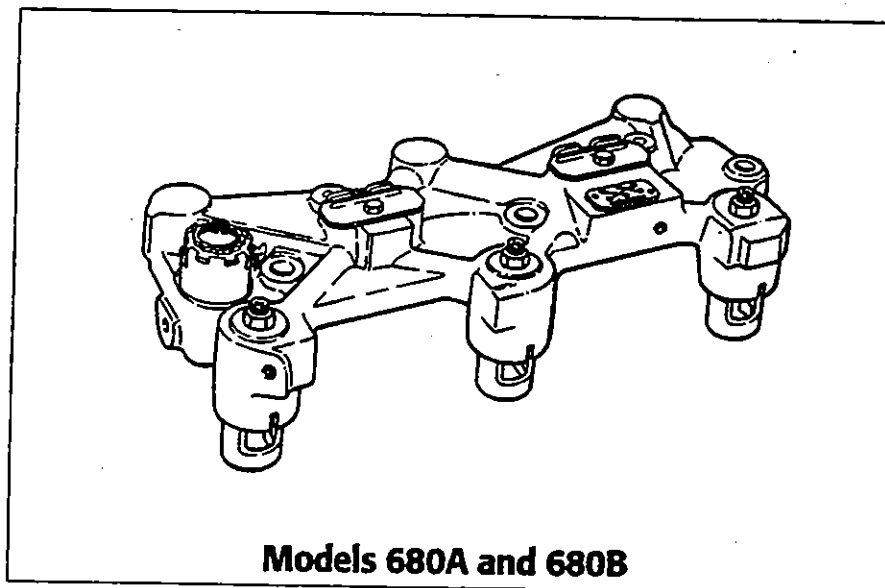

Fig. 1.7.2

## General Application Information

The Model 680B Jake Brake engine retarder is designed and approved for use on Mack \* E7 engines.

The Model 680A Jake Brake engine retarder is designed and approved for use on Mack \* E6 engines with four-valve cylinder head configuration.

The Model 675A Jake Brake engine retarder is designed and approved for use on all Mack 6 cylinder 672 and 711 CID automotive engines: E6, EC6, EM6 and EMC6. The Model 675A replaces the Model 675 in the Jacobs engine brake product line.

## Special Features/Procedures

Valve Stem Caps: Models 675 and 675A

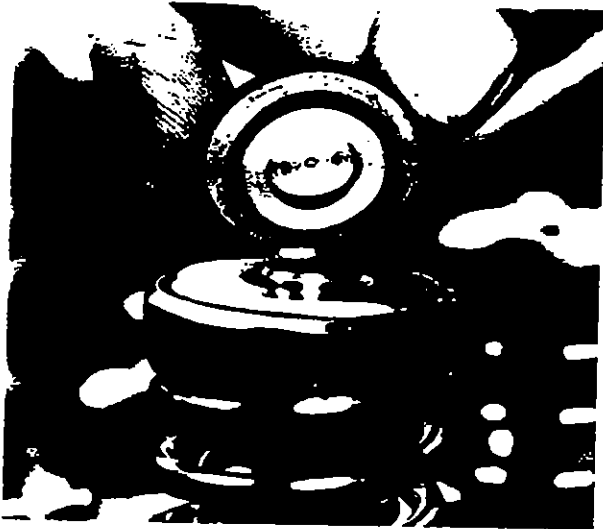

Fig. 1.7.3

### NOTE:

CURRENT ENGINES HAVE 0.345-INCH (11.1 MM) DIAMETER VALVE STEMS. USE JACOBS VALVE STEM CAP, P/N 009263, ON THESE ENGINES. MACK ENGINES WITH SERIAL NUMBERS BELOW 9V6755 CAN HAVE LARGER DIAMETER EXHAUST VALVE STEMS, 0.486-INCH (12.3 MM). JACOBS VALVE STEM CAP, P/N 002032, MUST BE USED ON THESE EARLIER ENGINES.

Place the Jacobs valve stem caps on top of each exhaust valve.

## Slave Piston Adjusting Screw



Fig. 1.7.4

### NOTE:

MODEL 675 USES AN ADJUSTING SCREW WITH A SPRING-LOADED PISTON AT THE SLAVE PISTON END. THE PLASTIC PISTON SEALS A HOLE IN THE TOP OF THE SLAVE PISTON DURING ENGINE BRAKE OPERATION.

MODEL 675A USES A SOLID ADJUSTING SCREW AND A SOLID SLAVE PISTON (NO HOLE THROUGH THE TOP).



Fig. 1.7.5



SOLID ADJUSTING SCREWS MUST NOT BE USED IN MODEL 675 HOUSINGS BECAUSE THE HOLD IN THE TOP OF THE SLAVE PISTON WILL NOT BE SEALED AND ENGINE BRAKING WILL BE LOST. EXCESS OIL WILL BE SPILLED IN THE OVERHEAD.



Inspect the plastic plunger in the Model 675 adjusting screw. It should move freely in the screw. Clean or replace the entire screw if the plunger does not move freely.

## Oil Supply Screw: Models 675 and 675A

### NOTE:

ENGINES MANUFACTURED PRIOR TO MARCH, 1986, HAVE A 1/4-20 THREADED HOLE FOR THE ROCKER SHAFT LOCKING SCREWS (SEE FIG. 1.7.6). THESE ENGINES REQUIRE JACOBS OIL SUPPLY SCREW, P/N 014043, AND WASHER, P/N 014104.

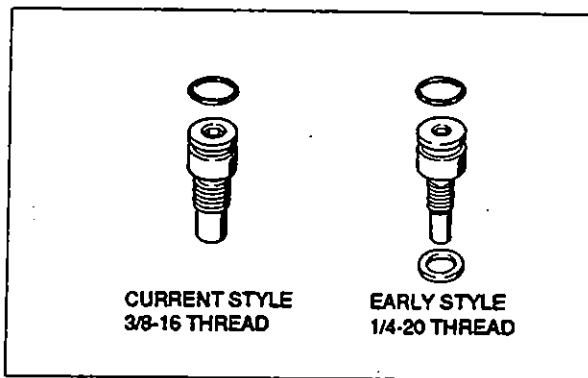

Fig. 1.7.6

## Slave Piston Adjustment

Models 675 and 675A require a fork-type feeler gauge for slave piston to valve cap clearance setting. This is required to be sure the valve stem cap is level with the slave piston when adjustment is made.

Models 680A and 680B require a single-blade feeler gauge for slave piston adjustment.

For correct adjustment procedures, clearance settings and feeler gauge part numbers, see Jacobs' installation and parts manuals and service publications.

## Exhaust Valve Yoke Replacement

Jacobs' exhaust valve yokes for 680A and 680B are the same. The adjusting screw threads are SAE and Jacobs' adjusting screw, P/N 011426, and nut, P/N 001026, can be used. The screw and nut used for the E6 engine (SAE threads) may also be used.

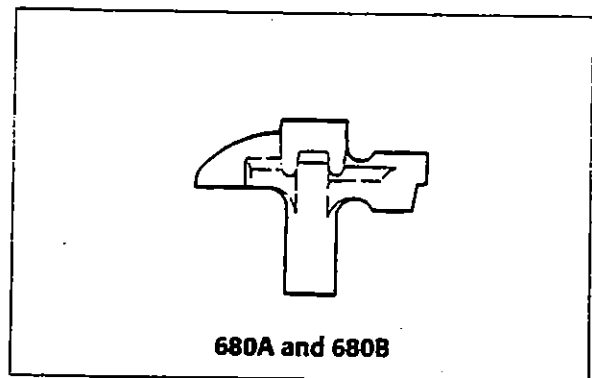

Fig. 1.7.7

# NOTES

## 2 Preventative Maintenance

### Introduction

The Jacobs Engine Brake is a relatively trouble-free and maintenance-free device. However, periodic inspection, cleaning and part replacement will need to be made from time to time. The time, mileage or hours shown in Fig. 2.1.1 are presented as a guide and should be included in the maintenance schedule of the engine/vehicle.

Severe driving conditions, types of roads, and driving areas will greatly affect the length of time between scheduled maintenance. Engines exposed to severe applications and operating environments may require more frequent preventative maintenance which would shorten engine brake maintenance intervals.

The recommended Maintenance Schedule shown in Fig. 2.1.1 is applicable to all engine brake models.

### Recommended Maintenance Schedule

Part	6 Months 50,000 Miles	12 Months 100,000 Miles 3,000 Hours	24 Months 200,000 Miles 5,000 Hours	48 Months 400,000 Miles 10,000 Hours
Wiring/Terminal Connections	I	I	I	I
Clutch/Throttle/Buffer SW	A	A	A	R
Solenoid Harness		I	R	R
Solenoid Seal Rings			R	R
Control Valve Springs			I	R
Control Valves			I	R
Oil Seal Rings		I	R	R
Master Piston Return Springs		I	I	R
Terminal Lead Out		I	I	R
Safety Valve Screw Assembly		I	I	R
Solenoid Valves				R
Reset/Auto-Lash® Assembly			I	I
Crosshead Pin Assembly		I	I	R
Crosshead/Bridges/Valve Stem Caps			I	I
Injector/Exhaust Rocker Arm Screws			I	I
Master Piston/Fork Assembly			I	I
Slave Pistons				I
External Hose Assembly			I	R
Housings			I	I
Fuel Pipes		I	I	R

I = Inspect/correct as required

A = Adjust

R = Replace

Fig. 2.1.1

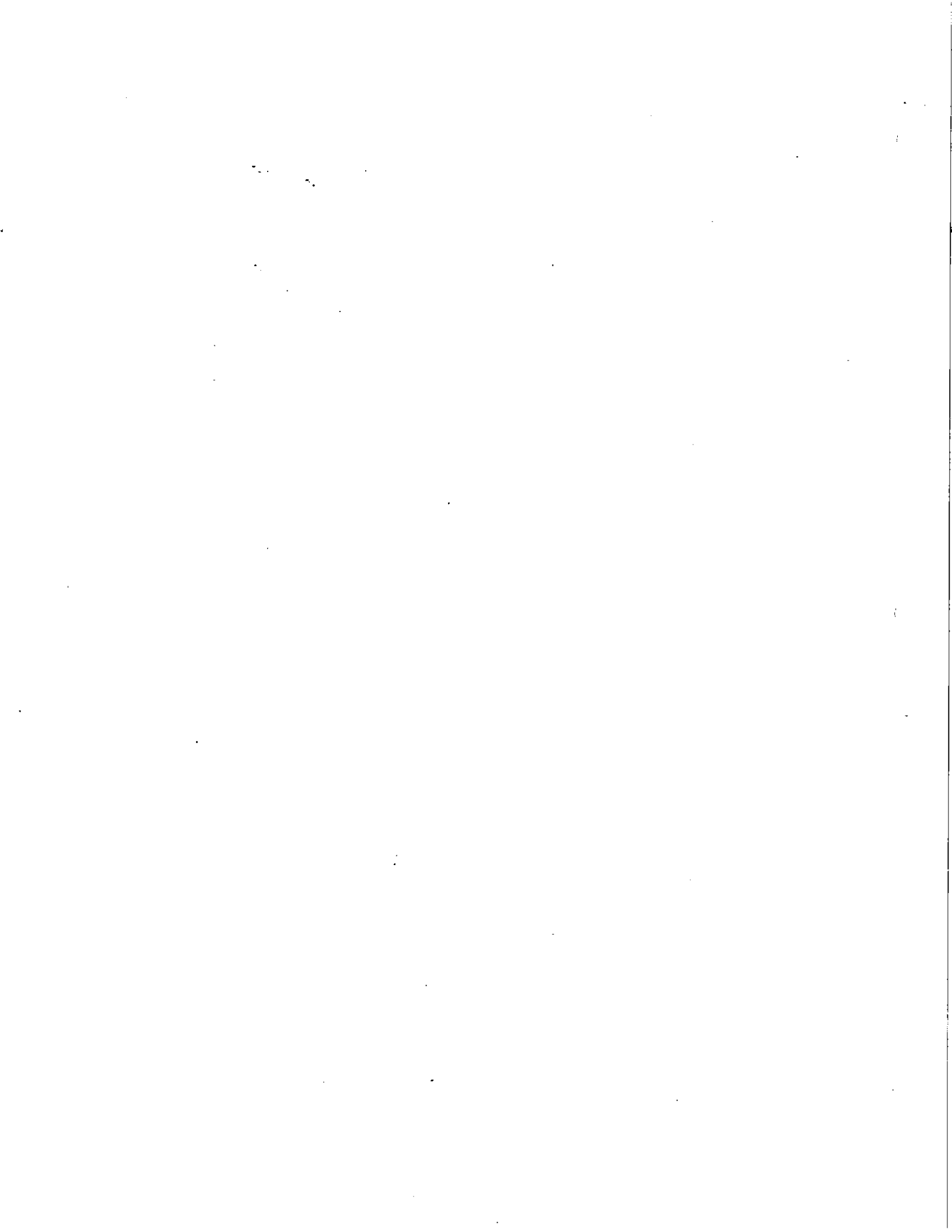

## 2.1 Inspection Criteria

### Safety Valve Screw Assembly Inspection

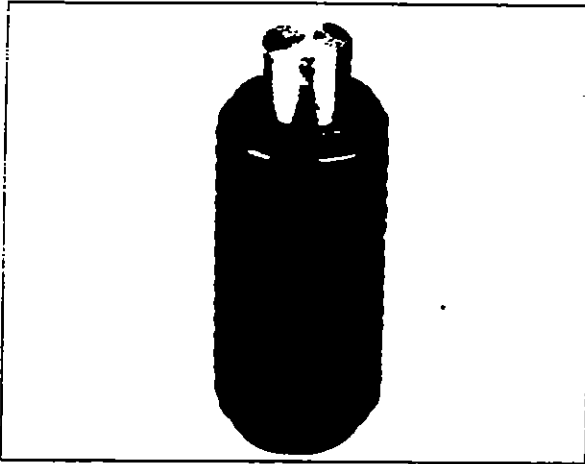

Fig. 2.1.2

1. Check the plunger in the safety valve screw. The plunger should protrude from the bottom of the screw, have light spring pressure apparent when depressed, and should move freely.
2. Inspect the area of the plunger which contacts the slave piston. The area should be flat and smooth.

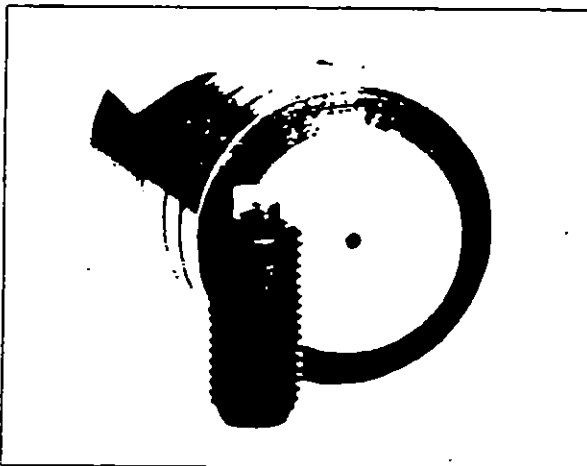

Fig. 2.1.3

3. Clean in an approved cleaning solvent and apply clean engine oil at reinstallation.

4. Ensure that the hole in the slave piston is visible through the threaded screw hole in the housing and aligns with the plunger.

**NOTE:**

The screw assembly cannot be disassembled in the field.

### Exhaust Crosshead/Bridge or Valve Stem Cap Inspection



Fig. 2.1.4

1. Check the hardened surface on the Jacobs exhaust crosshead/bridge/valve stem cap for excessive wear at either the point of rocker lever contact or slave piston contact. If the wear is 0.004" deep or more, the crosshead/bridge/cap must be replaced.



Fig. 2.1.5

2. Inspect the area of the valve stem cap that surrounds the valve stem for cracks or excessive wear. If any of these defects are visible, replace the valve stem cap.
3. Check the crosshead/bridge bore and valve stem contact areas. Ensure that they comply with applicable engine manufacturer's service parameters.

### Master Piston Inspection

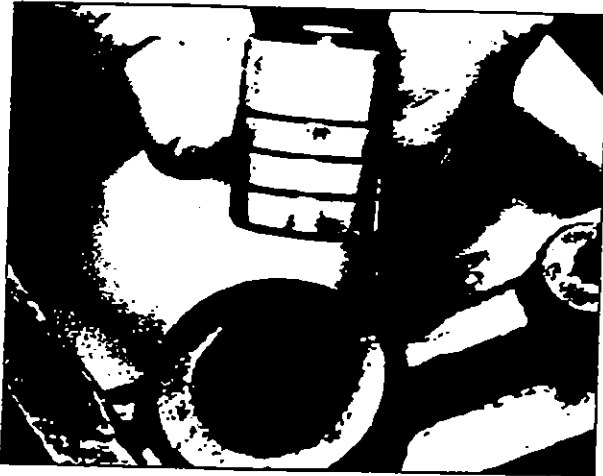

Fig. 2.1.6

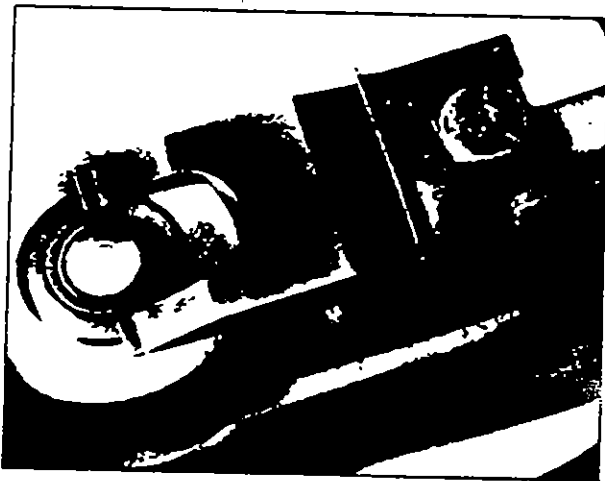

Fig. 2.1.7

1. Remove the master piston from the bore using needle nose pliers. The master piston should move smoothly in the bore. If binding occurs, check for burrs or contaminants in the oil. The sides of the master piston may show some polish but should not show extensive scoring, grooving or wear.
2. Inspect the hard face surface. Pitted, chipped, cracked or galled pistons should be replaced.
3. Coat the master piston with clean engine oil before reinstalling.

### Injector/Exhaust Rocker Arm Adjusting Screw Inspection

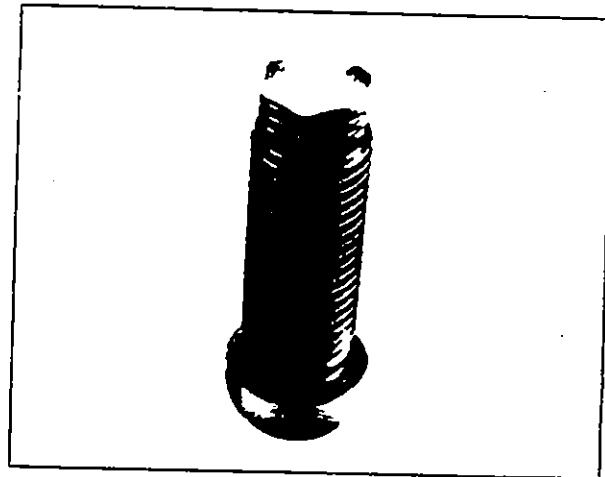

Fig. 2.1.8

1. Check both the hex head and spherical (ball) end surface of the adjusting screws. The spherical end should be checked for proper contour and smooth appearance.
2. Check the hex head for excessive wear. If a depression, 0.005" or deeper, is found in the top of the hex head, or if the pattern of "wipe" extends beyond the hex, replace the adjusting screw. Also replace the companion master piston.

## Slave Piston Inspection



Fig. 2.1.9



**Wear safety glasses. Follow instructions carefully.**  
The slave piston is retained by a spring under heavy compression. If instructions are not followed and proper tools are not used, the spring could be discharged with enough force to cause personal injury.

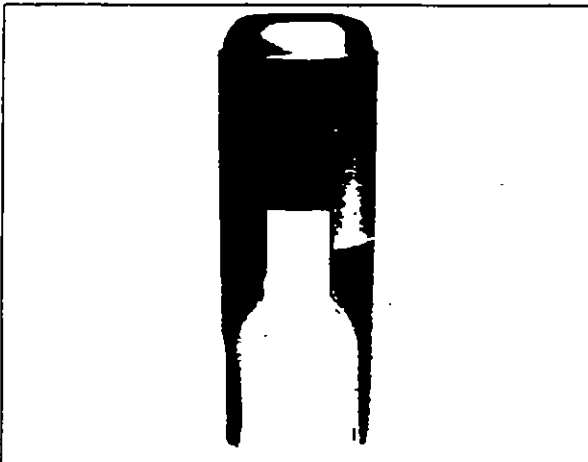

Fig. 2.1.10

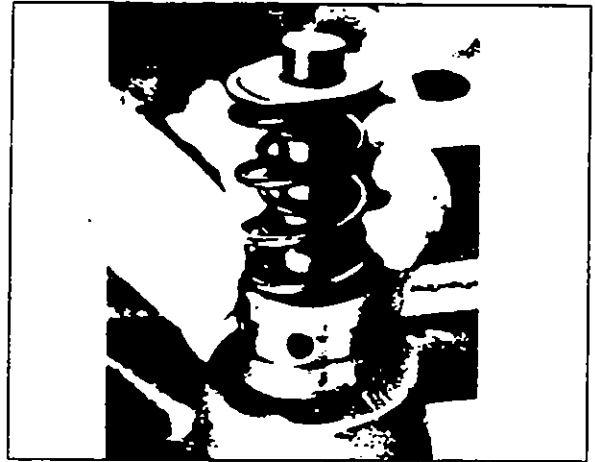

Fig. 2.1.11

1. Check for nicks or burrs that could cause binding. Clean the piston in an approved cleaning solvent. Replace the piston if the ground surface on the outside diameter looks questionable.
2. Run a small wire through the bleed holes in the single-valve and Caterpillar and Mack engine brakes.

## Crosshead Screw and Pin Assembly Inspection (Single-valve Opening)



Fig. 2.1.12

Inspect the crosshead pin assembly for the following:

1. Snap ring or grip ring present.
2. Cracks in screw body.
3. Wear on pin where valve stem is contacted.
4. Wear on screw where valve stem is contacted.
5. Bent pin.
6. Cracks in pin.

If any of these conditions are found, the pin assembly must be replaced. Also examine the slave piston for signs of wear at the contact point with the pin assembly.

### Slave Piston Adjusting Screws Inspection

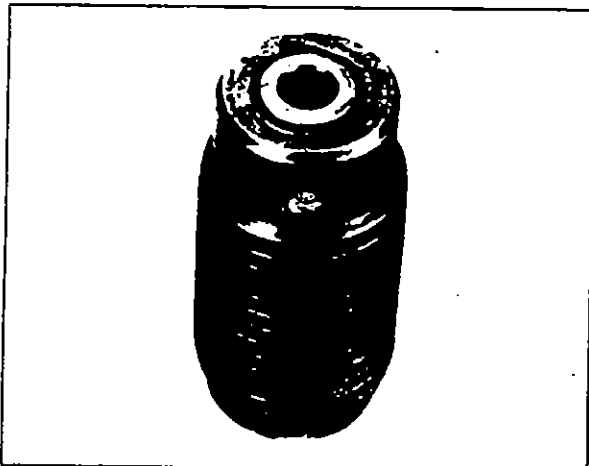

Fig. 2.1.13

1. Inspect Auto-Lash™ for proper plunger protrusion. Inspect for strong spring resistance when depressing plunger. Look for cracks in the screw body and replace the Auto-Lash if any cracks are found.

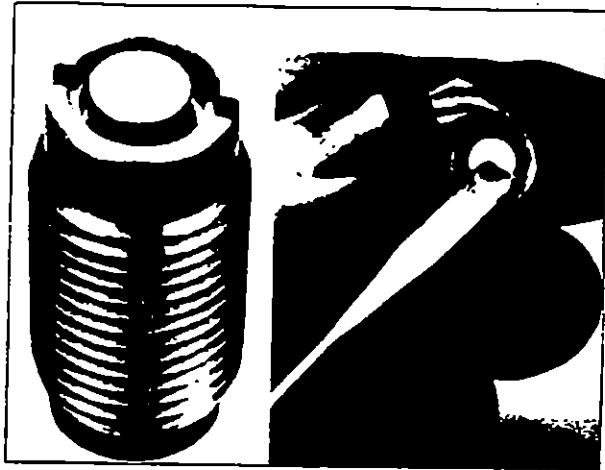
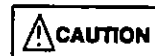

Fig. 2.1.14

2. Inspect the slave piston adjusting screw. The plunger should have light spring pressure apparent when depressed and should move freely. Be sure the retaining ring is fully engaged in its groove.
3. Clean in an approved cleaning solvent. Replace the entire screw if necessary.



Make no attempt to readjust or tamper with the adjusting screw. This could result in engine damage.

### Control Valve Inspection

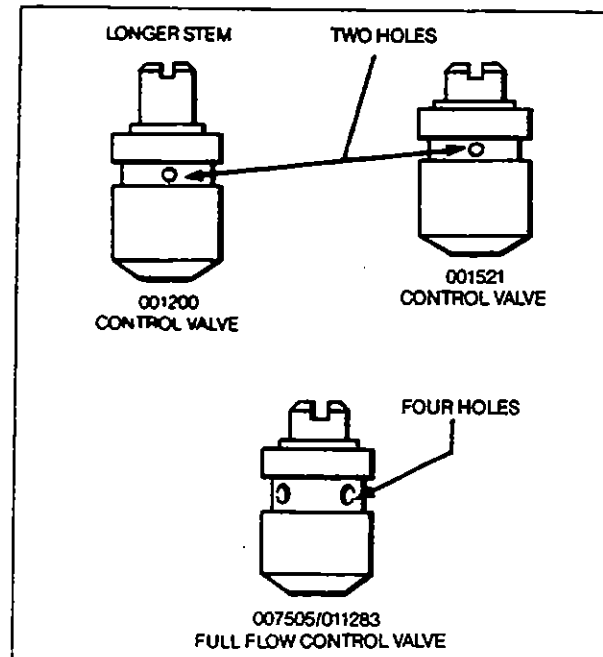

Fig. 2.1.15



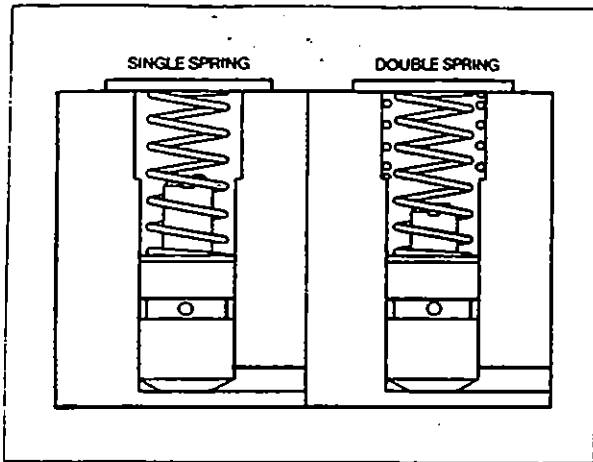

Fig. 2.1.16

1. Check to see that control valves move freely in their bores.
2. Wash control valves with an approved cleaning solvent. Insert a wire in the entrance hole in the base of the control valve to make sure the check ball is free and has light spring pressure.

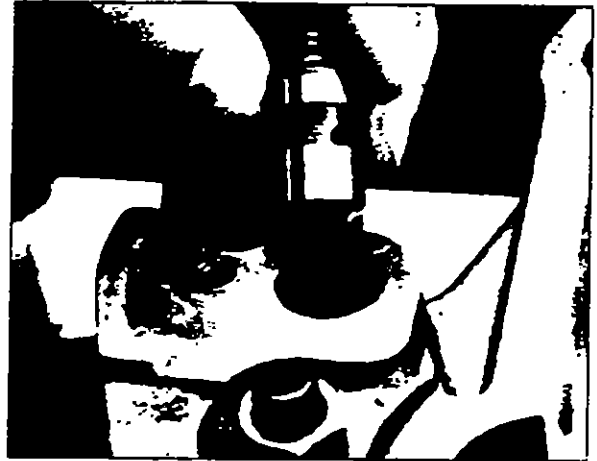
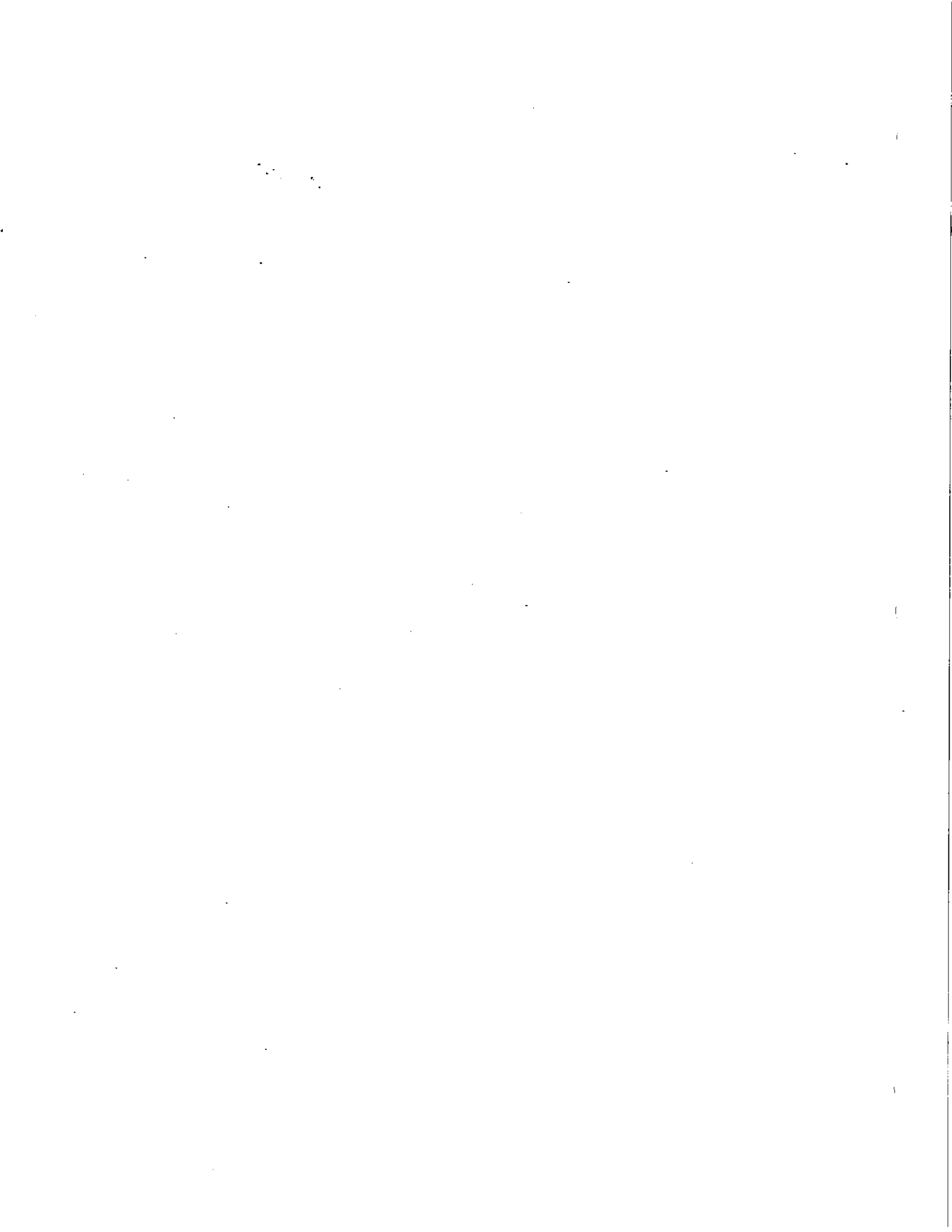

Fig. 2.1.17

3. Dip the control valves in clean lube oil.
4. Hold the valve at the top of its bore and release. When released, the valve should slowly settle under its own weight to the bore bottom. If binding occurs or the check ball is stuck, replace the control valve.



# DETROIT DIESEL

**Automotive  
370-500 BHP**

**SERIES 60®**

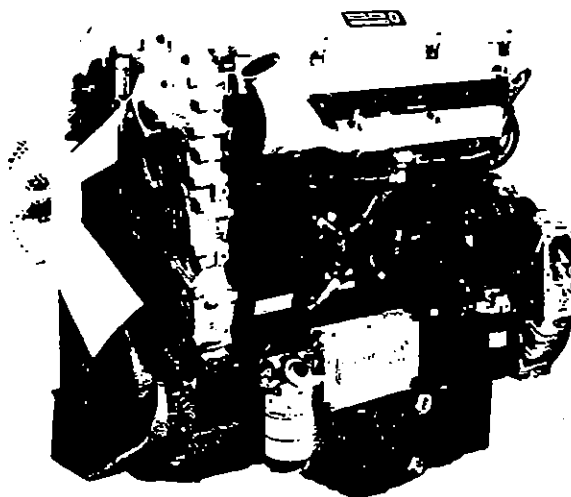

## General Specifications

Basic Engine	4 cycle
Model	6067GK60
Number of Cylinders	6 Inline
Air System	Turbocharged Air-to-Air Charge Cooling
Control	DDEC
Bore and Stroke	5.12 in x 6.30 in (130 mm x 160 mm)
Displacement	778 cu in (12.7 liters)
Compression Ratio	15.0 to 1
Length	57 in (1448 mm)
Width	34 in (864 mm)
Height	50 in (1273 mm)
Weight (dry)	2630 lbs (1193 kg)

## Rated Power Output

Maximum BHP @ RPM	Peak Torque @ RPM
<b>430HP FAMILY</b>	
370HP (276 kW) @ 1800	1450 lb. ft. (1966 N•m) @ 1200
400HP (298 kW) @ 1800	1450 lb. ft. (1966 N•m) @ 1200
430HP (320 kW) @ 1800	1450 lb. ft. (1966 N•m) @ 1200
370/400HP (276/298 kW) @ 1800	1450 lb. ft. (1966 N•m) @ 1200 CP
370HP (276 kW) @ 1800	1450 lb. ft. (1966 N•m) @ 1200
400HP (298 kW) @ 1800	1450 lb. ft. (1966 N•m) @ 1200
430HP (320 kW) @ 1800	1450 lb. ft. (1966 N•m) @ 1200
370/430HP (276/320 kW) @ 1800	1450 lb. ft. (1966 N•m) @ 1200 CP
370HP (276 kW) @ 2100	1450 lb. ft. (1966 N•m) @ 1200
400HP (298 kW) @ 2100	1450 lb. ft. (1966 N•m) @ 1200
430HP (320 kW) @ 2100	1450 lb. ft. (1966 N•m) @ 1200
370/430HP (276/320 kW) @ 2100	1450 lb. ft. (1966 N•m) @ 1200 CP
370HP (276 kW) @ 1800	1550 lb. ft. (2101 N•m) @ 1200
400HP (298 kW) @ 1800	1550 lb. ft. (2101 N•m) @ 1200
430HP (320 kW) @ 1800	1550 lb. ft. (2101 N•m) @ 1200
370/430HP (276/320 kW) @ 1800	1550 lb. ft. (2101 N•m) @ 1200 CP
430HP (320 kW) @ 1800	1550 lb. ft. (2101 N•m) @ 1200
430/470HP (320/350 kW) @ 1800	1550 lb. ft. (2101 N•m) @ 1200 CP
430HP (320 kW) @ 2100	1550 lb. ft. (2101 N•m) @ 1200
430/470HP (320/350 kW) @ 2100	1550 lb. ft. (2101 N•m) @ 1200 CP
<b>470HP FAMILY</b>	
470HP (350 kW) @ 1800*	1550 lb. ft. (2101 N•m) @ 1200
470HP (350 kW) @ 2100*	1550 lb. ft. (2101 N•m) @ 1200
470HP (350 kW) @ 2100*	1450 lb. ft. (2101 N•m) @ 1200
500HP @ 1800RPM*	1550 lb. ft. (2101 N•m) @ 1200
500HP @ 2100RPM*	1550 lb. ft. (2101 N•m) @ 1200

## Equipment Specifications

**DDEC**—Detroit Diesel Electronic Controls are standard on all Series 60 engines. This electronic unit fuel injector and engine management control system is the most advanced system available in the industry. DDEC includes state-of-the-art diagnostics for critical engine functions.

**Overhead Camshaft**—This design optimizes intake and exhaust air passages in the cylinder head for easier breathing, and minimizes valve train losses by eliminating the need for push rods.

**Short Ports**—The cylinder head has very short intake and exhaust ports for efficient air flow, low pumping losses and reduced heat transfer.

**Iron Crosshead Pistons**—The top ring can be placed much closer to the top of the iron crosshead piston. This reduces the dead volume above the top ring and improves fuel economy.

**Injector Rocker Arm with Ceramic Rollers**—The cam follower roller in the Series 60 injector rocker arm is made of silicon nitride. The low wear properties of this ceramic makes it possible to operate at very high injection pressures while maintaining long life of the roller. High injection pressure is one way Detroit Diesel is able to meet the stringent particulate and smoke emission standards without aftertreatments.

**Bearings**—The Series 60 features large main and connecting rod bearings for long life.

**Eight Head Bolts per Cylinder**—The head bolts provide a uniform load on the gasket and liner to reduce stress on the liner flange and block counterbore.

**High Efficiency Turbocharger**—Combined with a pulse-recovery exhaust manifold, the high efficiency turbocharger provides an efficient transfer of energy for improved fuel economy.

**Cruise Power**—This feature allows you to take advantage of additional torque and better performance when operating your truck in cruise control. The full rated torque is available when operating in cruise control, or in the PTO mode to improve performance. The higher torque improves driveability in hilly terrain and can improve fuel economy because fewer shifts are required and the engine operates closer to its optimum efficiency.

**Top Liner Cooling**—The Series 60 features top liner cooling. This has been accomplished by machining a coolant channel high up on the block, so that the top of the liner is surrounded by coolant, resulting in longer ring life.

### \*49 STATE RATINGS

Photograph illustrates a typical automotive engine.  
Rating conditions of SAE: 77°F (25°C) and 29.31 in Hg (99 kPa) Barometer (Dry)

For a complete listing of standard and optional equipment, consult your distributor or authorized Detroit Diesel Corporation representative.

## Performance Curves 370 BHP

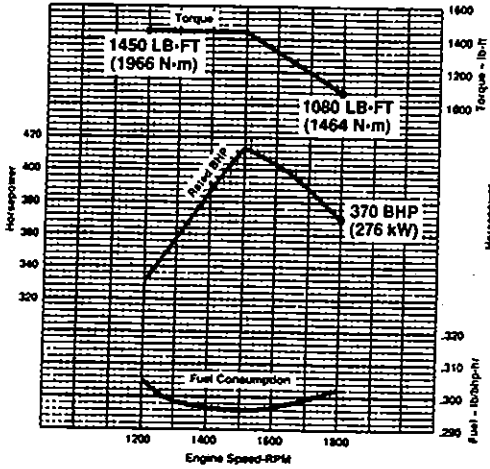

## 430 BHP

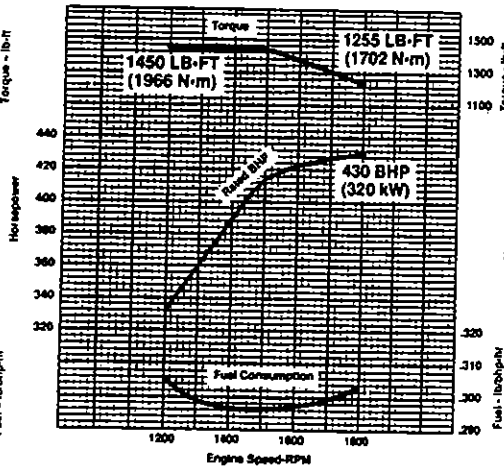

## 470 BHP

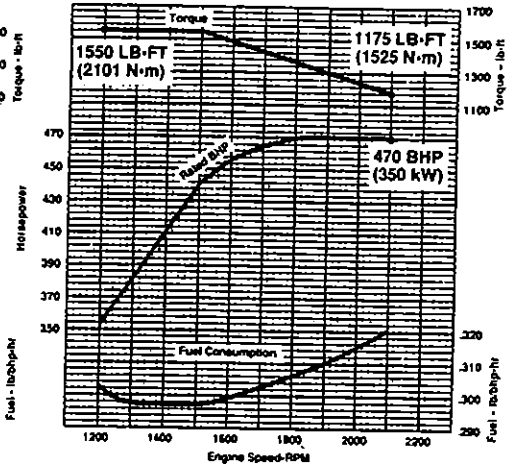

### Rating Explanation

RATED BHP is the power rating for variable speed and load applications where full power is required intermittently.

FUEL CONSUMPTION CURVE shows fuel used in pounds per brake horsepower hour.

THIS RATING does not include power requirements for accessory and standard equipment.

**Air-to-Air Charge Cooling**—To enhance fuel economy, the Series 60 has been designed to use air-to-air charge cooling. Air-to-air offers fuel economy gains of 2-5% over traditional intake air cooling systems. Incoming air is compressed by the turbocharger and directed to a finned heat exchanger in front of the vehicle's radiator. The heat exchanger uses no liquid coolant but relies instead on ram air for cooling the charge air resulting in lower intake air temperature from approximately 300°F(149°C) to below 100°F(38°C). This cooler air aids combustion, thereby increasing fuel economy.

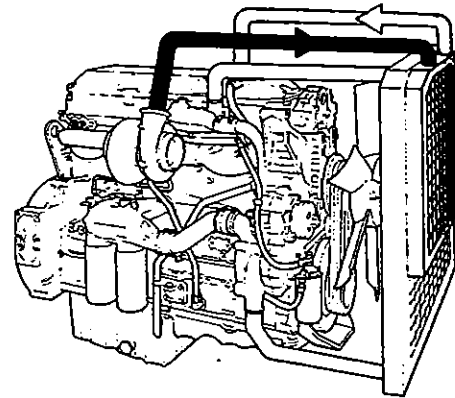

**Series 60**  
**24 Hour Hot Line**  
**Phone 1-800-445-1980**

**DETROIT DIESEL**  
CORPORATION



13400 Outer Drive, West / Detroit, Michigan 48239-4001  
Telephone: 313-592-5000  
FAX: 313-592-7288







## **SERIES 60**

### **A Success Story**

**T**he Detroit Diesel Series 60 engine has been a success from the start of production in 1987. The Series 60 was the first fully integrated heavy duty diesel engine with electronic controls in the world. Since then, the Series 60 continues to set the standard with innovative technology and superior fuel economy in the competitive heavy duty diesel engine market.

The DDC Series 60 engine has become the most popular in the class 8 truck market. We continue to increase our rate of production to satisfy market demand. Our team of engineering, manufacturing, and sales personnel strive to reach 7 goals:

- Do it right the first time
- Lower operating costs
- Understand and respond to our customer needs
- Establish long-term relations with suppliers
- Generate a high level of quality and productivity
- Provide outstanding engine performance
- Improve on all these goals

#### **Series 60 Horsepower**

The Series 60 engine offers a wide range of horsepower and torque options to match your vehicle vocation. The ratings governed at 1800 rpm offer excellent fuel economy. While the engines governed at 2100 rpm provide a wider operating range for owner/operators and specialty applications using automatic transmissions. The extended torque

in our engine calibration allows the driver to pull hills without shifting gears. This strong performance makes the Series 60 appealing to vehicle operators.

Detroit Diesel's Electronic Controls (DDEC) offers many features. Including a feature that allows a total of four horsepower ratings to be stored in one engine. The advantage to this is that horsepower can be changed for resale or as needed by just plugging the diagnostic data reader (DDR) into the vehicle dash. This feature enhances resale and is password protected.

### Cruise Power

Cruise power allows you to take advantage of additional torque and better performance when operating your truck in cruise control. Full rated torque is available when operating in cruise control to improve performance. The higher torque improves driveability in hilly terrain and can improve fuel economy because fewer shifts are required and the engine operates closer to its optimum efficiency.

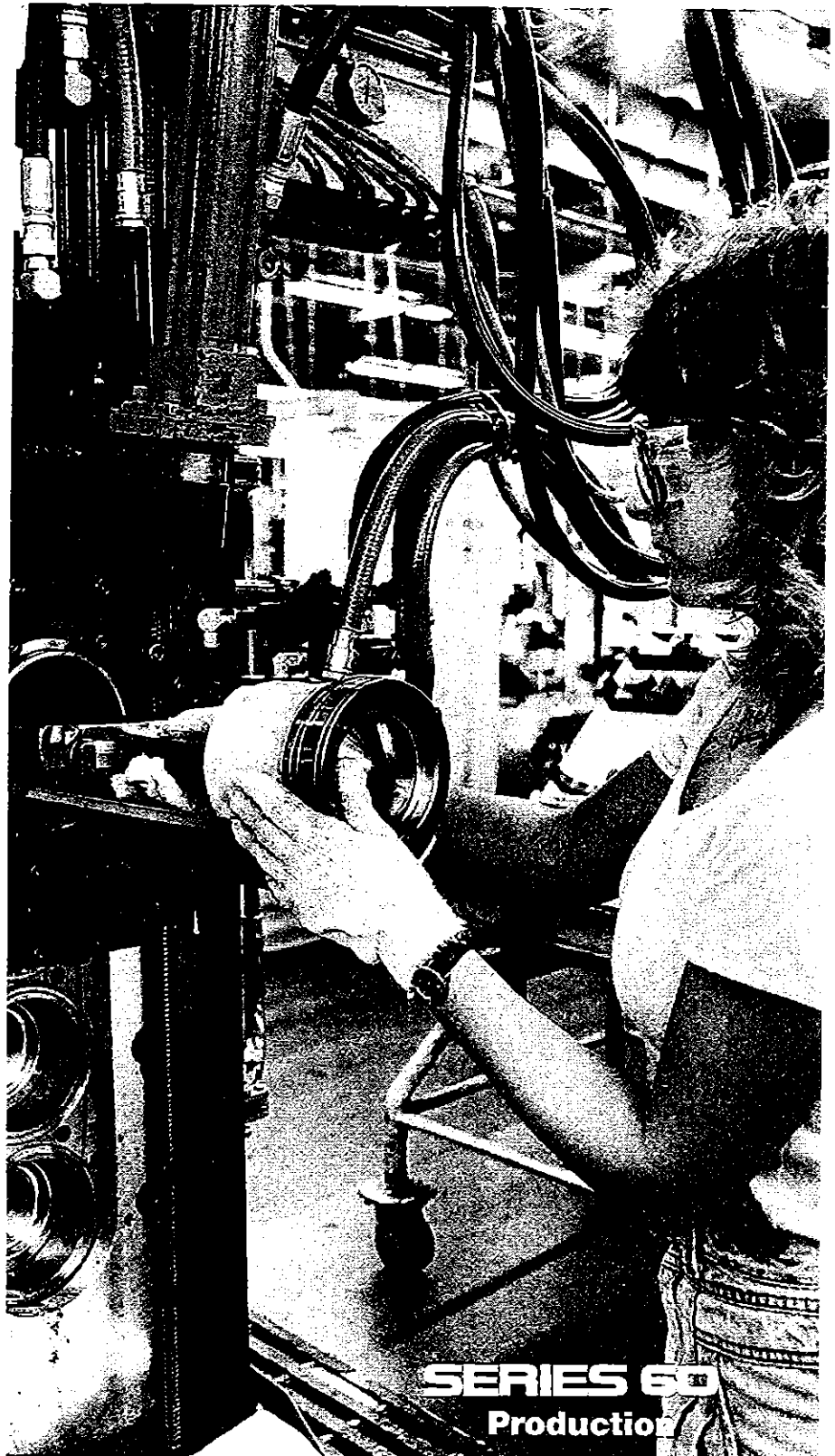
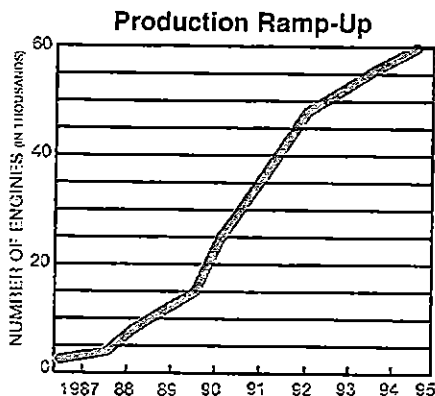



**Series 60 –  
Technology  
Exceeding  
Today's Standards**

### **Overhead Camshaft**

DDC engineers optimized the design of the engine by incorporating an overhead camshaft. This eliminates push rods, lifters and 40 wear surfaces. The benefits of this design are:

- Stronger overhead design
- Fewer parts
- Easier to service
- Lower exhaust emissions
- Less internal engine friction
- Better fuel economy

### **Top Liner Cooling**

Detroit Diesel has a patented feature called top liner cooling. This is a channel machined in the top portion of the liner and block that allows engine coolant to flow around the liner. Why is this important?

- Cooler cylinder temperatures
- Longer ring life
- Longer piston life

### **Pistons**

The two piece cast iron crosshead piston has small clearances to the plateau honed cast iron cylinder liner. This is possible since both parts are made of the same material. The benefits are:

- Stronger parts
- Less wear at cold start up
- Reduced noise
- Lower exhaust emissions

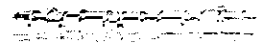
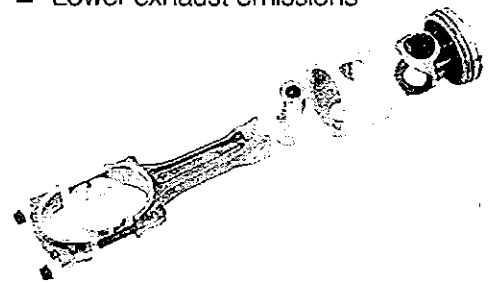



### Cylinder Head Design

With the overhead cam design, the Series 60 has 8 headbolts per cylinder evenly spaced to provide a uniform clamping load. This design provides a one million pound clamping force to hold the head to the block, which eliminates head gasket leaks.

### Intake and Exhaust

Our engineers kept the design of the intake and exhaust ports simple. Using an overhead cam and 4 valves per cylinder allows the engine to breathe freely. Air flows in one side of the engine and out the other. Why is this important?

- Cooler running engine
- More efficient, so horsepower losses are lower

### Ceramic Rollers

The cam follower roller in the Series 60 injector rocker arm is made of silicon nitride. This ceramic material has high strength and low wear properties. The advantages are:

- More durable
- Longer life

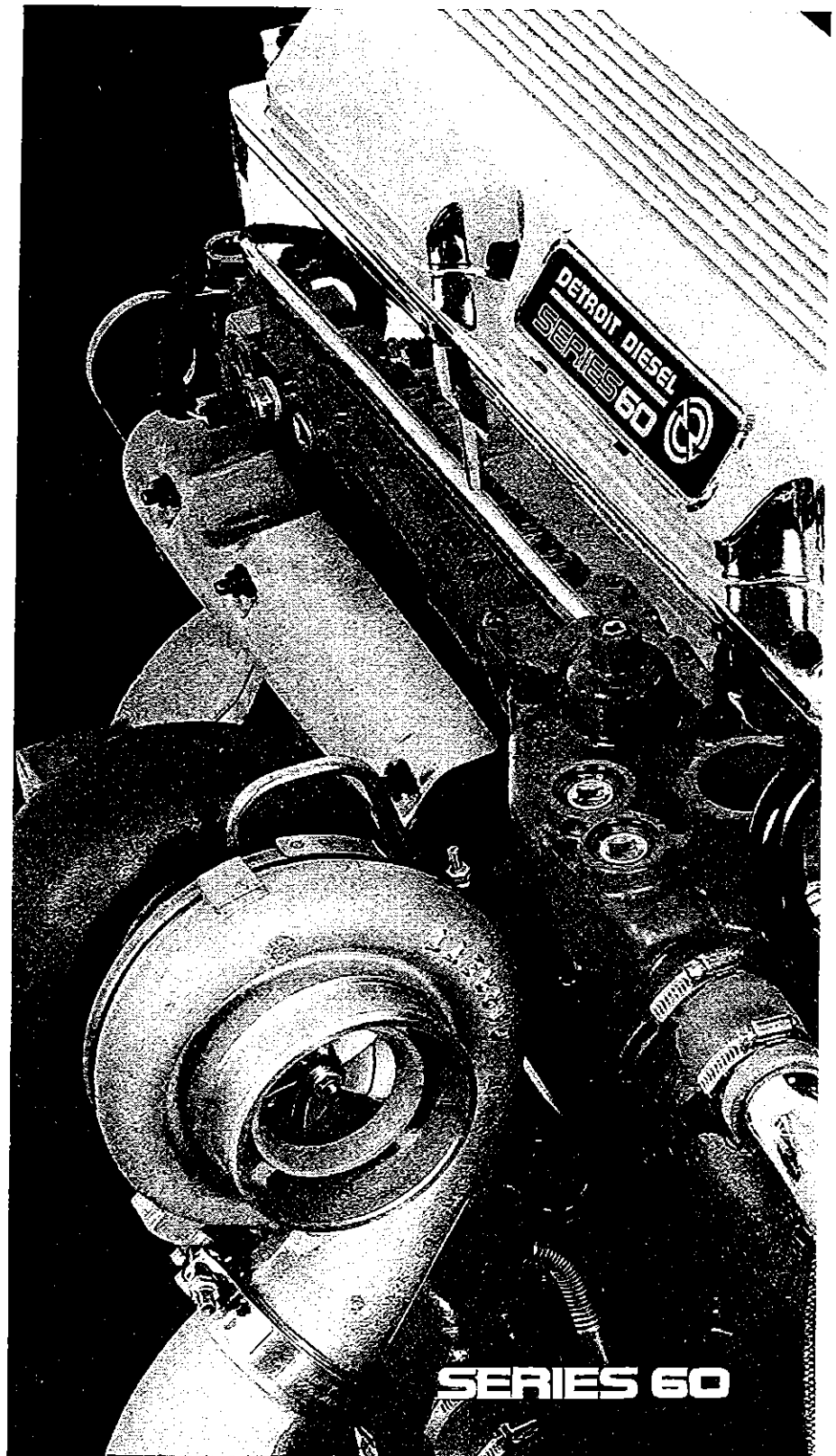
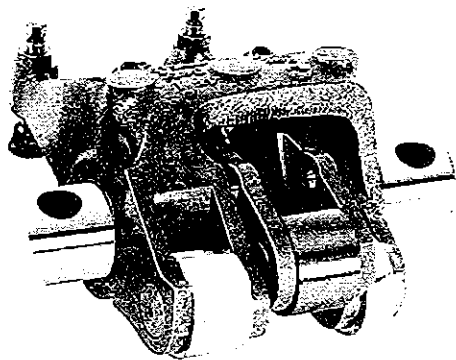

**SERIES 60**

## **Detroit Diesel Electronic Controls DDEC III**

# T

he Series 60 features integral electronic controls called Detroit Diesel Electronic Controls (DDEC III).

Its major components are the Electronic Control Module (ECM), the Electronic Unit Injectors (EUI), and the engine sensors. The ECM is the computer that receives electronic inputs from the driver as well as engine mounted sensors. Engine speed information is used to control both the quantity of fuel injected and injection timing.

The EEPROM chip (Electrically Erasable Programmable Read Only Memory) is located in the ECM and contains the operating software. This software controls the horsepower, torque, and maximum engine speed. Additional software is programmed into the EEPROM to control the engine protection devices, vehicle speed limiting, and cruise control that can be set with a Diagnostic Data Reader (DDR) to optimize specific fleet requirements. A list of DDEC III sensors and features are shown in the chart on the next page.



*Diagnostic Data Reader*



## The Leader In Electronic Injectors

The electronic unit injector works on the same basic principle as the mechanical unit injector with the simple addition of an electronically controlled solenoid valve that meters fuel input.

Our electronic injectors are self-compensating and greatly reduces the need for tune-ups.

With electronic controls, fuel economy is improved and the exhaust emissions are kept low in the following ways:

- The electronic governor limits maximum RPM to a preset value. This allows for precise control over maximum vehicle speed.
- Variable injection timing provides exceptional fuel economy, by taking into consideration the temperature, load, speed and turbo boost.
- Electronic diagnostic procedures can be used to help locate specific problems.
- Since electronics control injection timing, as well as the quantity of fuel, the Series 60 can start unaided at 10°F (-12°C).
- The ECM controls the maximum vehicle speed within the most efficient engine operating range.

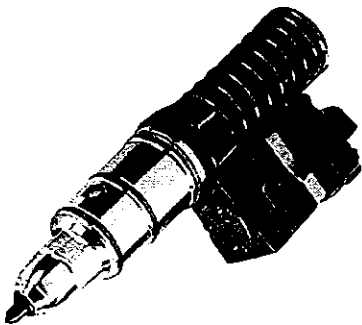

*Electronic Unit Injector*

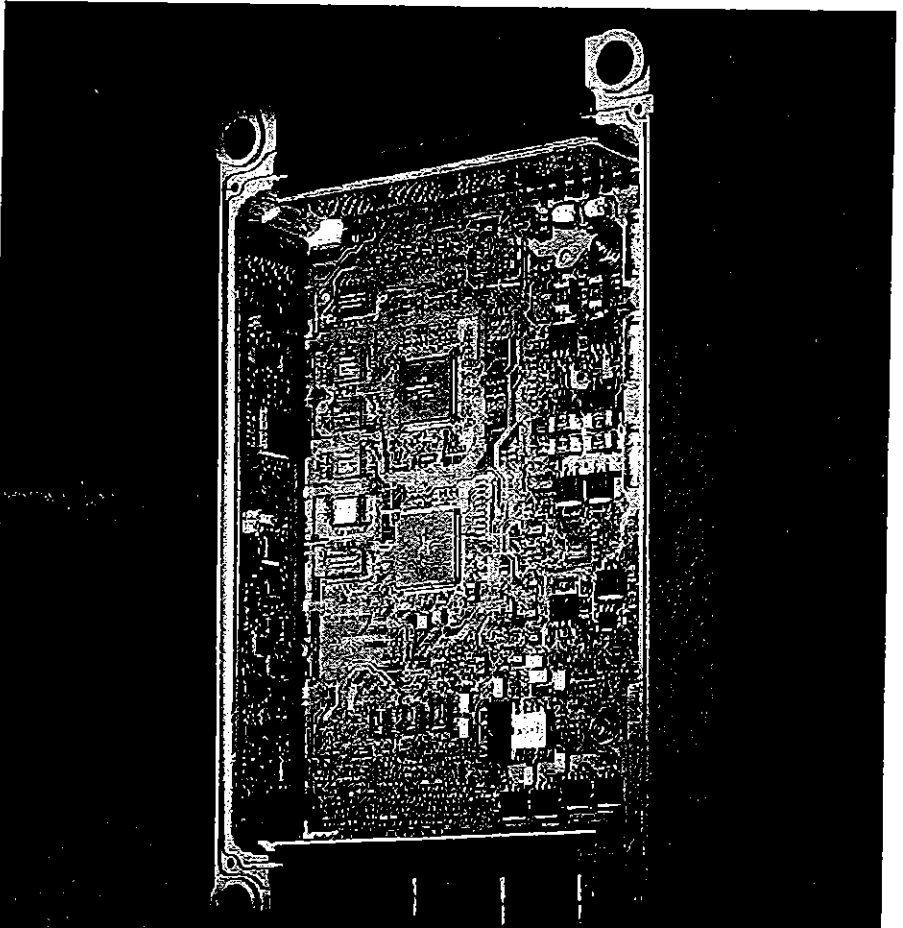

## DDEC III ECM

### DDEC III sensors:

- Coolant temperature
- Oil temperature
- Oil pressure
- Coolant level
- Throttle position
- Speed, timing
- Air temperature (air intake manifold)
- Fuel pressure
- Turbo boost
- Vehicle speed

### DDEC III software features:

- Cruise control
- Cruise power
- Controls on/off fans
- Controls engine braking
- Engine fan braking
- Vehicle speed limiting
- Cruise control automatic resume with double clutching

- Low DDEC voltage light
- Low coolant light
- Vehicle power shutdown
- Idle timer shutdown
- Manual fan control override
- Idle adjustment
- Customer password
- Horsepower password
- Maximum security
  - Locks out all changes to ECM
- Communication links
  - SAE J1587, J1922, J1939
- Progressive shifting
- Pressure governor
- Starter lockout
- Engine protection
- Starter lockout deceleration light
- Firetruck controls
- Ether start controls
- Optimized idle
- Air temperature shutdown



**DDEC III -  
Don't Be Left  
Behind...  
Step Into  
The Age Of  
Electronics**

**T**he DDEC ECM provides state-of-the-art control and monitoring, as well as a stored summary of engine performance. ProDriver™ takes the process further by providing the driver and fleet manager with access to the vital data provided by DDEC via the SAE diagnostic data link. The concept is further extended with the Data Logger™, which provides monitoring of the engine and other electronic systems, combined with substantial storage capacity, fuel tax data collection, flexible data extraction and communication capabilities. ProManager™ PC software extracts and analyzes data from the DDEC ECM, ProDriver and Data Logger systems. This comprehensive "expert" analysis allows managers to take action immediately, instead of spending hours trying to analyze the situation.

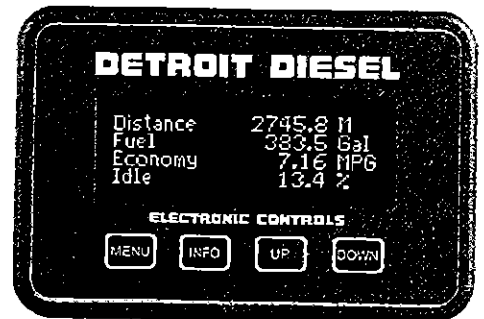

**Data Hub Family of Products**

- TRAC software
- ProDriver
- Data Logger
- ECM Data Pages
- ProManager software

## 1,000,000 Miles

Most Series 60 engines that have accumulated over half a million miles have encountered few problems. Durability was substantiated when a Series 60 with over 1,000,000 miles was torn down and inspected. What was revealed at teardown?

- Cylinder block and head had no distress or cracks.
- Gear case, oil pan, and major castings are reusable.
- Liners showed original honing marks.

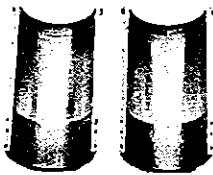

- Liner seals showed no leakage.
- Pistons had no cracks or distress and minimal wear.

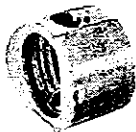

- Crankshaft was reusable.
- Gear train was in excellent reusable condition.

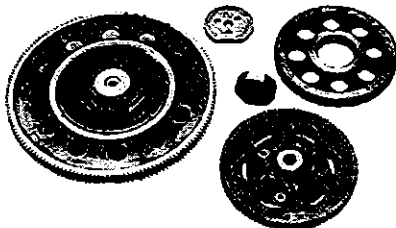

- Camshaft had no distress and only required grinding on one lobe.
- Valves showed very low wear.

The Series 60 manufacturing process contributes to the high level of quality and durability of the Series 60.

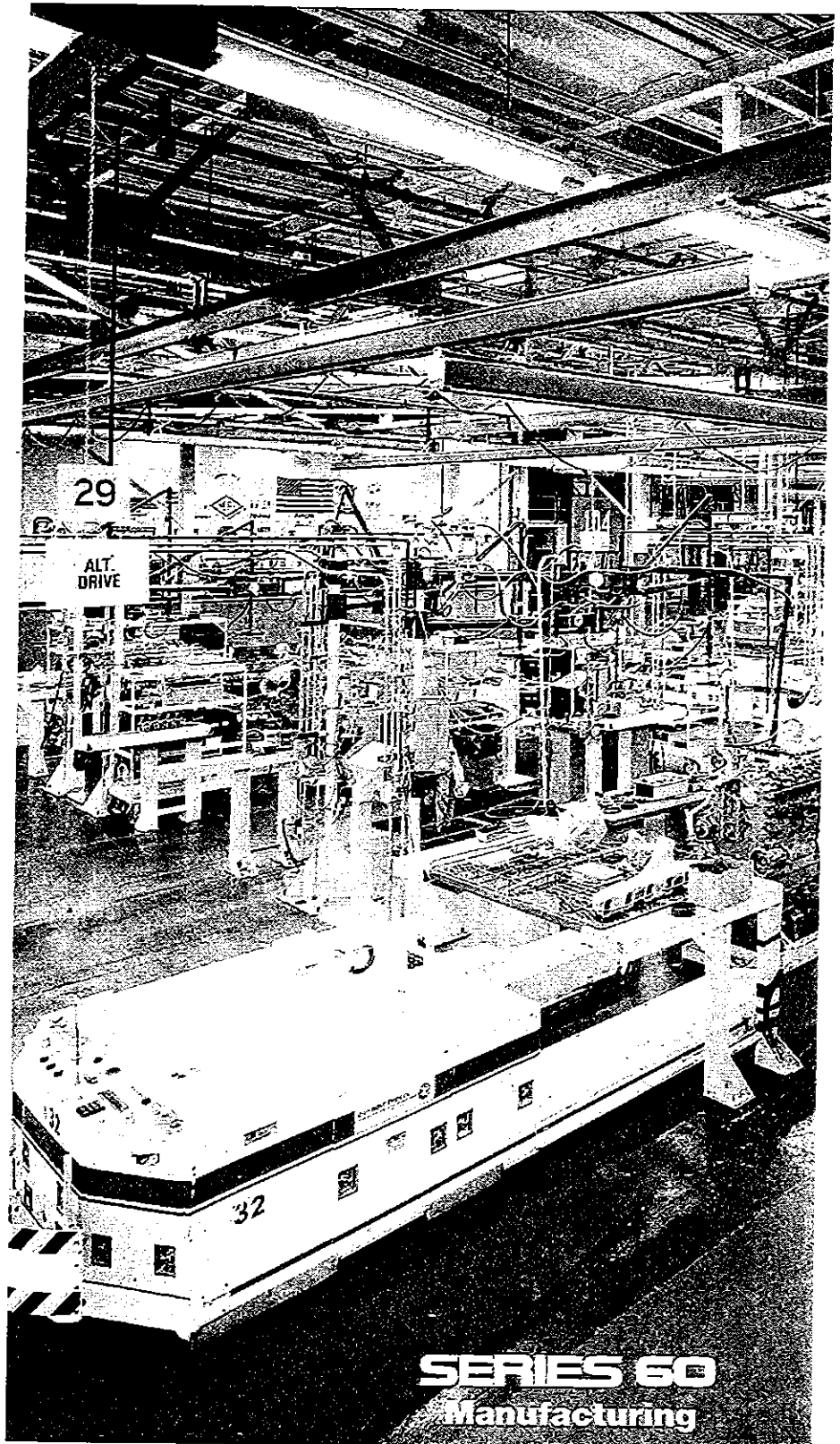

**SERIES 60**  
Manufacturing

## Superior Fuel Economy

Detroit Diesel has broken the 0.300 brake specific fuel consumption (BSFC) barrier. This is a milestone in heavy duty diesel engine technology. The Series 60 is the first engine in the world to achieve this exceptional level of performance. Customers average 6-8 mpg with heavy loads. With lighter loads, the fuel economy is even more incredible. Our technology exceeds today's standards. Detroit Diesel is racing ahead, and we are not looking back.

### Max BHP @ RPM      Peak Torque @ RPM

Max BHP @ RPM	Peak Torque @ RPM
<b>330HP FAMILY</b>	
300HP @ 1800RPM	1150FT-LB @ 1200RPM
330HP @ 1800RPM	1150FT-LB @ 1200RPM
300/330HP @ 1800RPM	1150FT-LB @ 1200RPM CP
330HP @ 1800RPM	1250FT-LB @ 1200RPM
350HP @ 1800RPM	1250FT-LB @ 1200RPM
330/350HP @ 1800RPM	1250FT-LB @ 1200RPM CP
330HP @ 2100RPM	1250FT-LB @ 1200RPM
325HP @ 2100RPM**	1350FT-LB @ 1200RPM
325/350HP @ 2100RPM**	1350FT-LB @ 1200RPM
330HP @ 2100RPM	1350FT-LB @ 1200RPM

<b>365HP FAMILY</b>	
330HP @ 1800RPM	1350FT-LB @ 1200RPM
350HP @ 1800RPM	1350FT-LB @ 1200RPM
365HP @ 1800RPM	1350FT-LB @ 1200RPM
330/350HP @ 1800RPM	1350FT-LB @ 1200RPM CP
330HP @ 1800RPM	1350FT-LB @ 1200RPM
350HP @ 1800RPM	1350FT-LB @ 1200RPM
365HP @ 1800RPM	1350FT-LB @ 1200RPM
330/365HP @ 1800RPM	1350FT-LB @ 1200RPM CP

<b>430HP FAMILY</b>	
370HP @ 1800RPM	1450FT-LB @ 1200RPM
400HP @ 1800RPM	1450FT-LB @ 1200RPM
430HP @ 1800RPM	1450FT-LB @ 1200RPM
370/400 @ 1800RPM	1450FT-LB @ 1200RPM CP
370HP @ 1800RPM	1450FT-LB @ 1200RPM
400HP @ 1800RPM	1450FT-LB @ 1200RPM
430HP @ 1800RPM	1450FT-LB @ 1200RPM
370/430 @ 1800RPM	1450FT-LB @ 1200RPM CP
370HP @ 2100RPM	1450FT-LB @ 1200RPM
400HP @ 2100RPM	1450FT-LB @ 1200RPM
430HP @ 2100RPM	1450FT-LB @ 1200RPM
370/430 @ 2100RPM	1450FT-LB @ 1200RPM CP
370HP @ 1800RPM	1550FT-LB @ 1200RPM
400HP @ 1800RPM	1550FT-LB @ 1200RPM
430HP @ 1800RPM	1550FT-LB @ 1200RPM
370/430 @ 1800RPM	1550FT-LB @ 1200RPM CP
430HP @ 1800RPM	1550FT-LB @ 1200RPM
430/470 @ 1800RPM	1550FT-LB @ 1200RPM CP
430HP @ 2100RPM	1550FT-LB @ 1200RPM
430/470 @ 2100RPM	1550FT-LB @ 1200RPM CP

<b>470HP FAMILY</b>	
470HP @ 1800RPM*	1550FT-LB @ 1200RPM
470HP @ 2100RPM**	1550FT-LB @ 1200RPM
470HP @ 2100RPM*	1450FT-LB @ 1200RPM
500HP @ 2100RPM**	1450FT-LB @ 1200RPM
500HP @ 1800RPM*	1550FT-LB @ 1200RPM
500HP @ 2100RPM*	1550FT-LB @ 1200RPM

\*49 STATE RATINGS  
\*\*BUS RATINGS ONLY

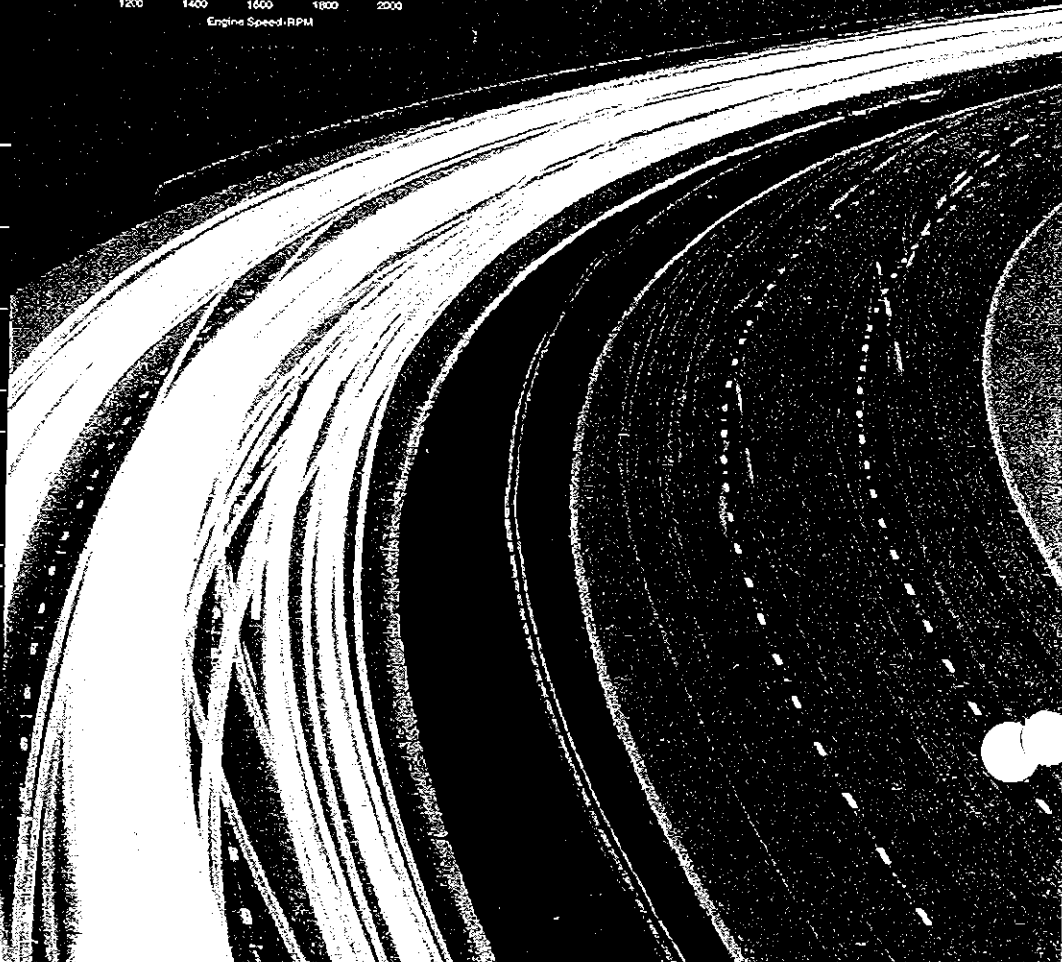
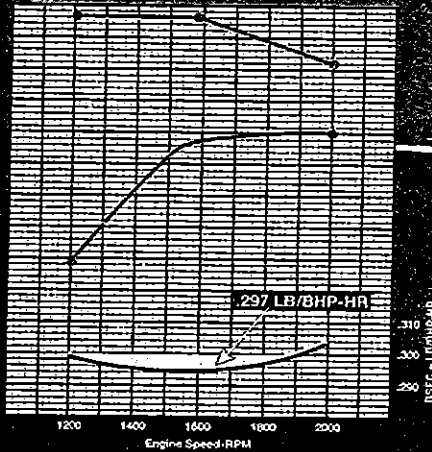



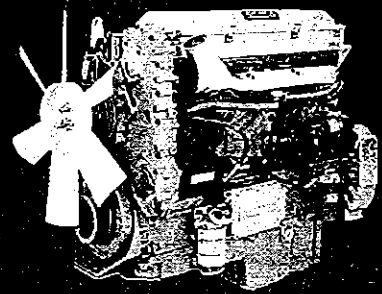

**SERIES 60**

## Parts and Training Support

Your dealer maintains a stock of quality Detroit Diesel parts and is ready to respond to your needs. Service personnel have been trained by our DDC distributors or at our world class training headquarters. They are experts in the

proper application, care and maintenance of your Series 60 engine.

You can participate in an extensive engine maintenance and overhaul training program in our training facilities. You will leave

with the insight and skills needed to diagnose and troubleshoot almost any engine malfunction on the spot.

Detroit Diesel Corporation is committed to providing excellent service for customers. Nowhere is this commitment more evident than in our Series 60 engine.

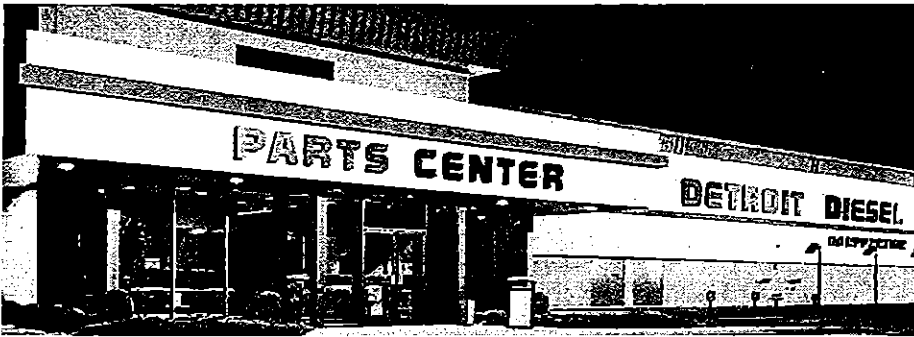

*Detroit Diesel Parts Center, Canton, Ohio*

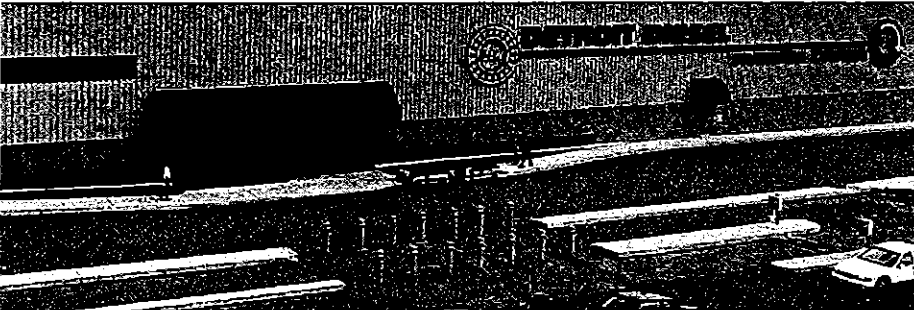

*Detroit Diesel Training Center, Redford, Michigan*

**Series 60**  
**24 Hour Hot Line**  
**Phone 1-800-445-1980**

**DETROIT DIESEL**  
CORPORATION



13400 Outer Drive, West / Detroit, Michigan 48239-4001  
Telephone: 313-592-5000  
FAX: 313-592-7288





# SECTION 02: CLUTCH

---

## CONTENTS

1. CLUTCH.....	2
1.1 Description.....	2
2. CLUTCH ADJUSTMENT .....	2
2.1 Clutch Pedal Adjustment.....	2
2.2 Internal Clutch Adjustment.....	3
2.3 Free Travel Setting.....	4
2.4 Air Pressure Regulator.....	4
3. RENEW CLUTCH HYDRAULIC LINE.....	4
3.1 Bleeding.....	4
3.2 Filling.....	5
4. LUBRICATION .....	5
5. TROUBLESHOOTING.....	6
6. SPECIFICATIONS .....	8

## 1. CLUTCH

### 1. Description

Vehicles equipped with a manual transmission are provided with the "Spicer" Angle-Spring clutch. The clutch assembly consists of a 15.1/2" dry disc two-plate model. It is a pull-type design with riveted organic wear surface facing on driven discs. It is manually adjustable to compensate wear, hydraulically operated and pneumatically assisted. A torque limiting clutch brake as well as a positive separator pin system are also provided. One type of clutch is installed regardless of transmission (6 or 7 speeds).

Refer to the Spicer, Service manual annexed to the end of this section for the following subjects:

- Transmission Removal

**Note:** For more details, refer to section 07 "Transmission".

**Note:** Disconnect the clutch operating cylinder external linkage and remove cylinder assembly (without disconnecting hydraulic hose), to permit the release yoke to turn up and pull free of the release bearing thrust pads, then disconnect the transmission shift linkage.

- Clutch Removal
- Engine and Transmission Alignment (Inspection)
- Clutch Installation
- Transmission Installation

**Note:** For more details, refer to Section 07 "Transmission"

**Note:** Position the torque limiting clutch brake on the main drive gear of the transmission, then shift transmission into gear so that the input shaft can be rotated during assembly to align with clutch-driven disc hub splines.

**Note:** Rotate clutch release bearing housing so that flat section is on top.

**Note:** Rotate clutch release yoke so that release yoke fingers clear the pads on the release bearing housing. Use a suitable transmission jack to support and maintain the engine-to-transmission alignment while installing the transmission. Use care to avoid having the weight of the transmission bearing on the clutch or forcing the transmission into the clutch or flywheel housing. Such abuse can cause bent or "sprung" driven discs and prevent the clutch from releasing. Rotate clutch release yoke into proper position as transmission is moved into place.

**Note:** Start all transmission bell housing cap screws and tighten progressively around the housing to 45 lbf•ft (61 N•m).

**Note:** Connect the transmission shift linkage. Install the clutch operating cylinder and its linkage, then proceed with the clutch adjustment in accordance with paragraph 2.

## 2. CLUTCH ADJUSTMENT

**Note:** if for any reason, air is present inside clutch hydraulic line, bleed clutch in accordance with paragraph 3.1.

### 2.1 Clutch Pedal Adjustment

Adjust clutch pedal as follows:

1. Free play adjustment is made by loosening nut (1, Fig. 1) and moving bolt in slot. The pedal moves down allowing a 1/4" (6 mm) of free play before the master cylinder (5, Fig. 1) starts to move.
2. Keep this adjustment by tightening nut (1, Fig. 1).
3. Push the clutch pedal until the master cylinder piston touches the cylinder bottom.

4. Loosen the adjustment bolt (2, Fig. 1) until it touches the pedal wall support (3, Fig. 1).
5. Loosen the adjustment bolt (2, Fig. 1) for another 1-1/2 turn. Lock in position by tightening nut (4, Fig. 1).

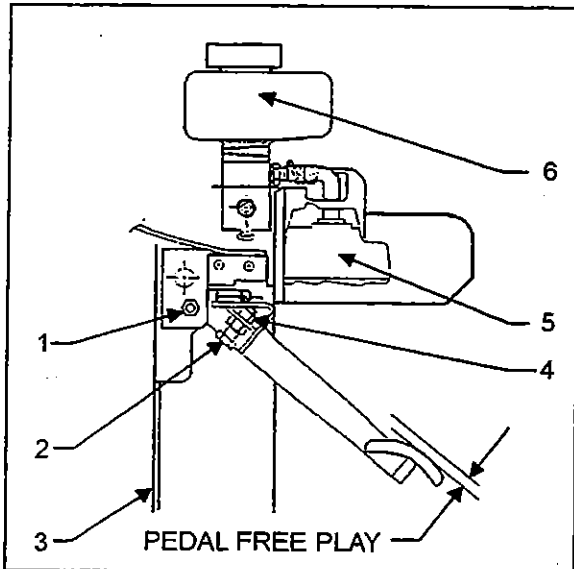

Figure 1: Free Play Adjustment OE43B716

**Note:** Clean reservoir internal pieces with jet air to eliminate dirt.

## 2.2 Internal Clutch Adjustment

1. Remove inspection cover at bottom of clutch housing (Fig. 4).
2. Measure the **release travel** (clearance between release bearing housing and clutch brake). Refer to figure 2. The clearance should be between 1/2" and 9/16" (13 and 14 mm).
3. If clearance is incorrect, release the clutch by depressing the clutch pedal to end of pedal travel. Insert a 3/4" socket (12 points) or a 3/4" box-end wrench through inspection hole. Depress square-head bolt to adjust clutch (Fig. 3 and 4).

The "Kwik-Adjust" will re-engage at a quarter of a turn. The flat surface on the bolt head will align with the flat edge of the bracket.

**Note:** If clearance between release bearing housing and clutch brake is less than 1/2" (13 mm), rotate the adjusting ring counterclockwise to move the release bearing towards the engine. If clearance is greater than 9/16" (14 mm), rotate the adjusting ring clockwise to move the release bearing towards the transmission.

4. Ensure "Kwik-Adjust" is engaged in the locked position. Release the clutch pedal to engage clutch.

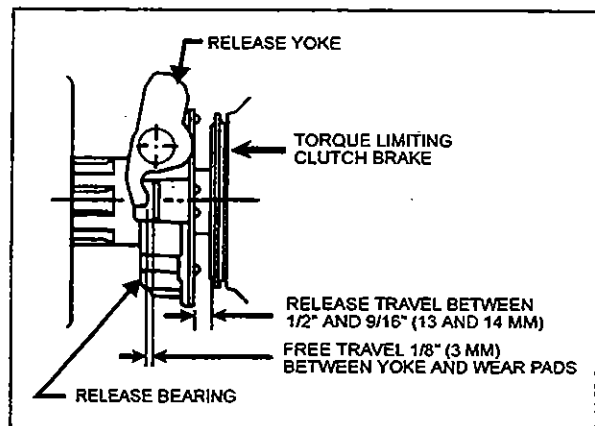

Figure 2: Release Travel And Free Play Travel Adjustment MA3E0223

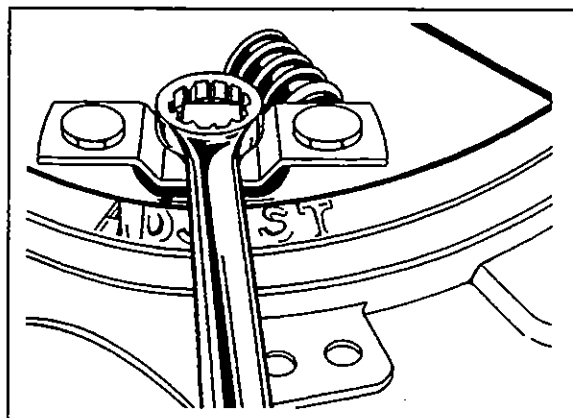

Figure 3: Square Head Bolt MA3E0224

## Section 02: CLUTCH

### 2.3 Free Travel Setting

1. Check **free travel** as shown in figure 2. The clearance should be 1/8" (3 mm).
2. If clearance is incorrect, adjust bolt until it touches the shaft lever and locks in position with nut (Fig. 4).

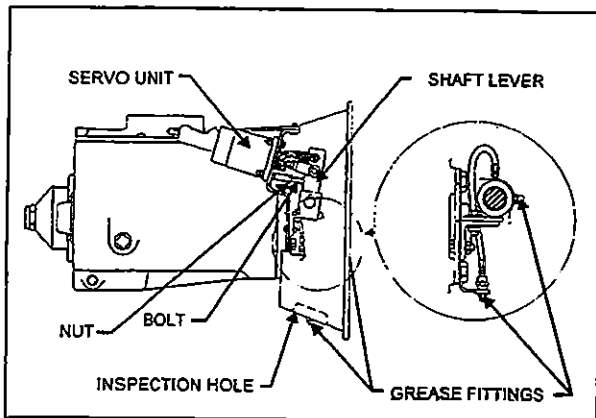

Figure 4: Clutch Installation

02001

**Note:** The return springs do not require any tension adjustment.

### 2.4 Air Pressure Regulator

The air pressure regulator is located in engine R.H. side door (Fig. 5). To adjust, remove dust cap from regulator. Attach a pressure gauge to port. Loosen adjusting screw lock nut. Turn screw to **adjust pressure to 40 psi**. Tighten lock nut, then reinstall dust cap. Refer to Section 12, Brake and Air System, page 8, Figure 5.



Figure 5: Air Pressure Regulator

02003

## 3. RENEW CLUTCH HYDRAULIC LINE

### 3.1 Bleeding

The clutch hydraulic system must be bled whenever air enters it. Unlike hydraulic fluid, air is compressible. This means that instead of transmitting pedal pressure through the hydraulic line, the master cylinder will compress air in the line. This results in a spongy feel in the pedal, incomplete clutch disengagement and hard shifting.

**Note:** Two people are required to bleed air from the hydraulic lines. One to operate the clutch pedal and the other to open and close the bleed valve.

**Warning:** Wear safety glasses during the following operation.

1. Locate the bleed valve mounted at the end of servo unit. Remove dust cap (Fig. 4 and 6).
2. Attach a plastic tube to the bleeding valve (Fig. 6). Dip the other end of the tube in a jar containing several inches of clean brake fluid.

**Note:** Do not allow the end of the tube out of the brake fluid during bleeding. This could allow air into the hydraulic system, requiring that the bleeding procedure be done over.

3. Press the clutch pedal as far as it will go 2 or 3 times, then hold it down.
4. With the clutch pedal down, open the bleeding valve until the pedal goes to the floor, then close the bleeding valve. Do not let the pedal up until the bleeding valve is closed.
5. Let the pedal back up slowly.
6. Repeat steps 4-6 until the fluid entering the jar is free of air bubbles.

### 3.2 Filling

1. Remove the master cylinder reservoir cap.
2. Slightly loosen teflon flexible hydraulic hose connector from adaptor mounted on extremity of servo unit (Fig. 6).

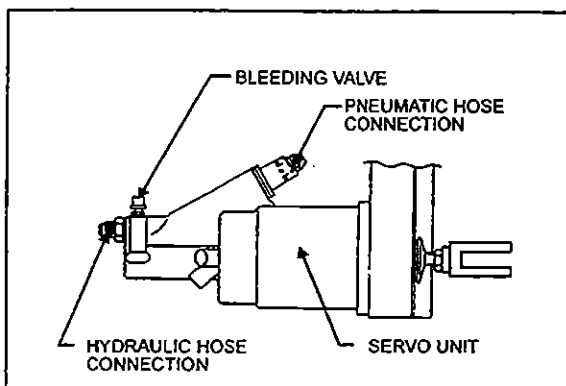

Figure 6: Servo Unit

02002

3. Remove the plastic tube on the bleeding valve. Make sure the bleeding valve is open. Force fluid (meeting DOT 3 specifications) through the bleeding valve opening. Tighten teflon flexible hose connector when fluid is free of air

bubbles. Continue to force brake fluid until it enters master cylinder reservoir and flows free of air bubbles.

**Note:** A 40 psi (275 kPa) pressure allows filling hydraulic line in reasonable time.

4. Tighten bleeding valve and reinstall dust cap.
5. Fill master cylinder reservoir.
6. Install the master cylinder reservoir cap.

**Note:** To make the filling procedure easier to perform, the reservoir support may be unbolted and reservoir moved closer to you.

**Caution:** Never re-use brake fluid which has been bled from the system. Discard old brake fluid and use a fresh supply.

### 4. LUBRICATION

The clutch components should be lubricated every 6,250 miles (10 000 km) or twice a year, whichever comes first (refer to previous Fig. 4 to identify the clutch component grease fittings). The clutch release bearing (one grease fitting) and the clutch control cross shaft (three grease fittings, two on the operating cylinder side and one on the other side) should be lubricated with a good quality lithium-based soap or equivalent E.P. grease meeting N.L.G.I. grades 1 or 2.

## 5.TROUBLESHOOTING

Poor Clutch Release or Poor Engagement	
Probable cause	Corrective action
Clutch adjustment incorrect.	Recheck adjustment as per instructions.
Air in clutch hydraulic line.	Bleed clutch hydraulic line as per instructions.
Flywheel pilot bearing too tight in flywheel or on end of drive gear.	Free pilot bearing with a light push. If bearing is rough, replace it.
Damage clutch release bearing.	Replace bearing. Lubricate with recommended lube.
Clutch release shaft projecting through release yoke.	Relocate release shaft so that it does not project. Check bell housing bushing and release yoke for wear.
Release yoke contacting cover assembly at full release position.	Replace release yoke with proper yoke.
Release yoke not aligned properly with release bearing.	Check flywheel. Probably has been resurfaced more than the 0.060" (1,52 mm) recommended.
Intermediate plate sticking on drive lugs	Check that drive pins are 90° square to flywheel surface and that there is a minimum .006" (0,152 mm) clearance between drivepins and intermediate plate slots.
Pressure plate not retracting.	<ul style="list-style-type: none"> <li>a. Check pressure plate drive lugs for 0.006" (0,152 mm) clearance.</li> <li>b. Check pressure plate return springs for proper tension.</li> <li>c. Check amount of release travel.</li> <li>d. Lever nose out of groove.</li> </ul>
Driven disc distorted.	Should be straight within 0.015" (0,381 mm). Replace if distortion cannot be corrected.

**Section 02: CLUTCH**

<b>Poor Clutch Release or Poor Engagement (contd)</b>	
<b>Probable cause</b>	<b>Corrective action</b>
Worn splines on drive gear of transmission.	Check drive gear and driven disc hubs for excessive wear.
Disc facings gummed with oil or grease.	Replace facings or entire disc. Cleaning not recommended. Check for leak causing gumming.
Broken intermediate plate.	Replace entire intermediate plate/driven disc assembly. Damage such as this is almost always caused by abusive use of clutch.

<b>Clutch Slipping</b>	
<b>Probable Cause</b>	<b>Corrective action</b>
Pedal has no free play	Re-adjust as per instructions.
Release mechanism binding.	Check release mechanism and linkage. Lube if necessary.
Worn clutch facings.	Replace facings or complete disc, if necessary.
Grease or oil on facings.	Replace facings.
Weak pressure springs.	Replace springs
Overloaded clutch	Check to assure that proper clutch has been specified.

<b>Noisy Clutch</b>	
<b>Probable Cause</b>	<b>Corrective action</b>
Clutch release bearing dry or damaged.	Lubricate bearings or replace.
Flywheel pilot bearing dry or damaged.	Lubricate bearings or replace.
Clutch release bearing housing striking flywheel ring.	Adjust clutch. Also check wear on cross shafts, bell housing bushings and release yoke fingers. Replace if necessary.
Improper clearance between drive slots and drive lugs on pressure plates.	Clearance should be at least 0.006" (0,152 mm).

**Section 02: CLUTCH**

---

**6. SPECIFICATIONS**

**Clutch Adjustment**

Pedal free play ..... 1/4 ±1/8" (6±3 mm)  
Internal clutch adjustment ..... between 1/2-9/16" (13-14 mm)  
Free travel setting ..... 1/8" (3 mm)  
Clutch brake setting (between stopper and adjusting bolt) ..... between 1/4-3/8" (6-9 mm)

**Clutch Assembly**

Make ..... DANA Corp. (Spicer)  
Supplier number ..... 108391-78  
Prevost number ..... 52-0147  
Model ..... Easy Pedal  
Type ..... Dry, two-plate, pull-type, manually adjustable (Kwik- Adjust)  
Size ..... 15 1/2" (394 mm)  
Plate Load Capacity ..... 4000 lbs (17 792 N)  
Maximum Torque Capacity ..... 1450 lbf·ft (1966 N·m)  
Disc Facing Thickness ..... 0.487/0.452  
Hub Spline Size (No. splines) ..... 2" (10)  
Disc Assembly Max. Runout (T.I.R.) ..... 0.015" (0,381 mm)  
Disc Assembly Max. Out-of-Flat ..... 0.020" (0,508 mm)  
Release Sleeve Bushing Dia. (new) ..... 2.010/2.008" (51,054/51,003 mm)  
Intermediate Plates, driving lugs to slot clearance (new min.) ..... 0.006" (0,152 mm)  
Intermediate Plates, driving lugs to slot clearance (max. worn) ..... 0.015 to .021" (0,381 to 0,508 mm)  
Pressure Plates, driving lugs to slot clearance (new) ..... 0.003 to .010" (0,076 to 0,254 mm)  
Pressure Plates, driving lugs to slot clearance (max. worn) ..... 0.016/.021" (0,406/0,533 mm)  
Intermediate Plates & Pressure Plates: Out-of-Flat ..... 0.000 to .004 Concave (0,000 to 0,102 mm)  
Scoring - Max. depth that can be re-used ..... 0.015" (0,381 mm)  
Release Sleeve Retainer, driving lugs to slot clearance (max. worn) ..... 0.020" (0,508 mm)  
Maximum Engine RPM ..... 2600

**Master Cylinder**

Make ..... Kongsberg Automotive  
Supplier Number ..... 624409-P01  
Prevost Number ..... 52-0139

**Operating Cylinder (slave cylinder)**

Make ..... Kongsberg Automotive  
Supplier Number ..... 624410-P01  
Prevost Number ..... 52-0138





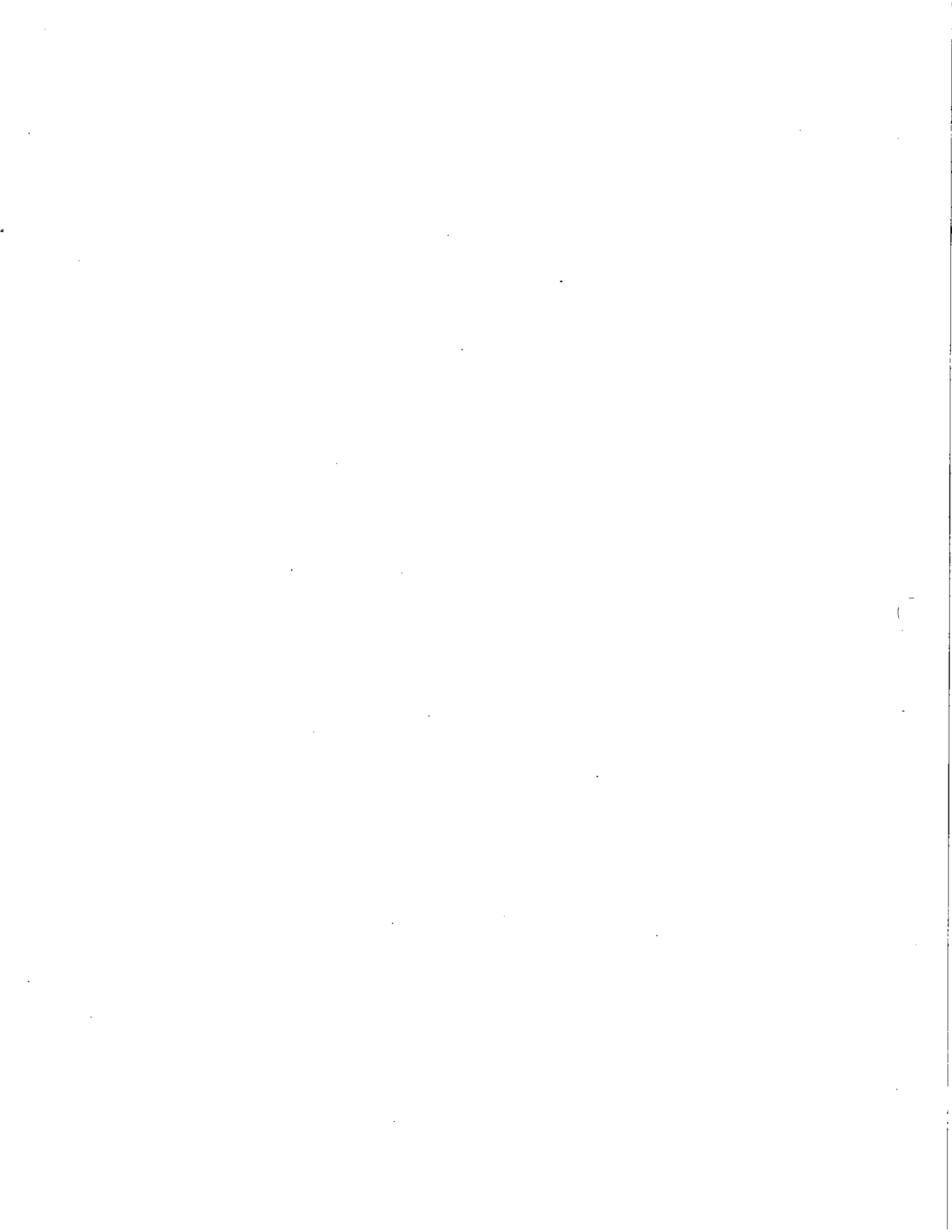

# SECTION 03: FUEL SYSTEM

---

## CONTENTS

1. FUEL SYSTEM .....	2
1.1 Description .....	2
2. FUEL LINES AND FLEXIBLE HOSES .....	3
3. FUEL VALVES .....	3
4. FILTERS AND WATER SEPARATOR .....	3
4.1 Fuel Filter/Water Separator Servicing .....	4
4.2 Fuel Filter Servicing (Primary and Secondary) .....	4
4.3 Preheater Fuel Filter .....	5
5. FUEL TANK .....	5
5.1 Tank Removal/Installation .....	5
6. PRIMING FUEL SYSTEM .....	6
7. FUEL PUMP INSTALLATION .....	6
8. FUEL OIL SPECIFICATIONS .....	7
9. AIR CLEANER (dry type) .....	7
9.1 Pre-Cleaner Servicing .....	7
9.2 Air Cleaner Servicing .....	7
9.3 General Recommendations .....	8
9.4 Air Cleaner Restriction Indicator .....	8
10. SPECIFICATIONS .....	9

# 1. FUEL SYSTEM

## 1.1 Description

A schematic of the fuel system is shown in figure 1. Fuel is drawn from the fuel tank through a manual shut-off valve, the primary fuel filter or water separator and enters the fuel pump. Leaving the pump under pressure, the fuel flows through the secondary fuel filter, a shut-off valve to cylinder head. The fuel flows to injectors in the cylinder head through passages integral with the head. Surplus fuel exits at the rear of the head just above the inlet, through a restrictive return fitting which maintains fuel pressure in the system. Finally, the fuel flows through the check valve and returns back to the fuel tank. Two preheaters are available: 40 000 BTU or 80 000 BTU. If the vehicle is equipped with the 40 000 BTU preheater, the fuel is drawn from the tank through the fuel pump to the preheater. If the vehicle is equipped with the 80 000 BTU preheater the fuel is drawn from the fuel tank through a fuel filter to the preheater. Excess fuel returns to the fuel tank.

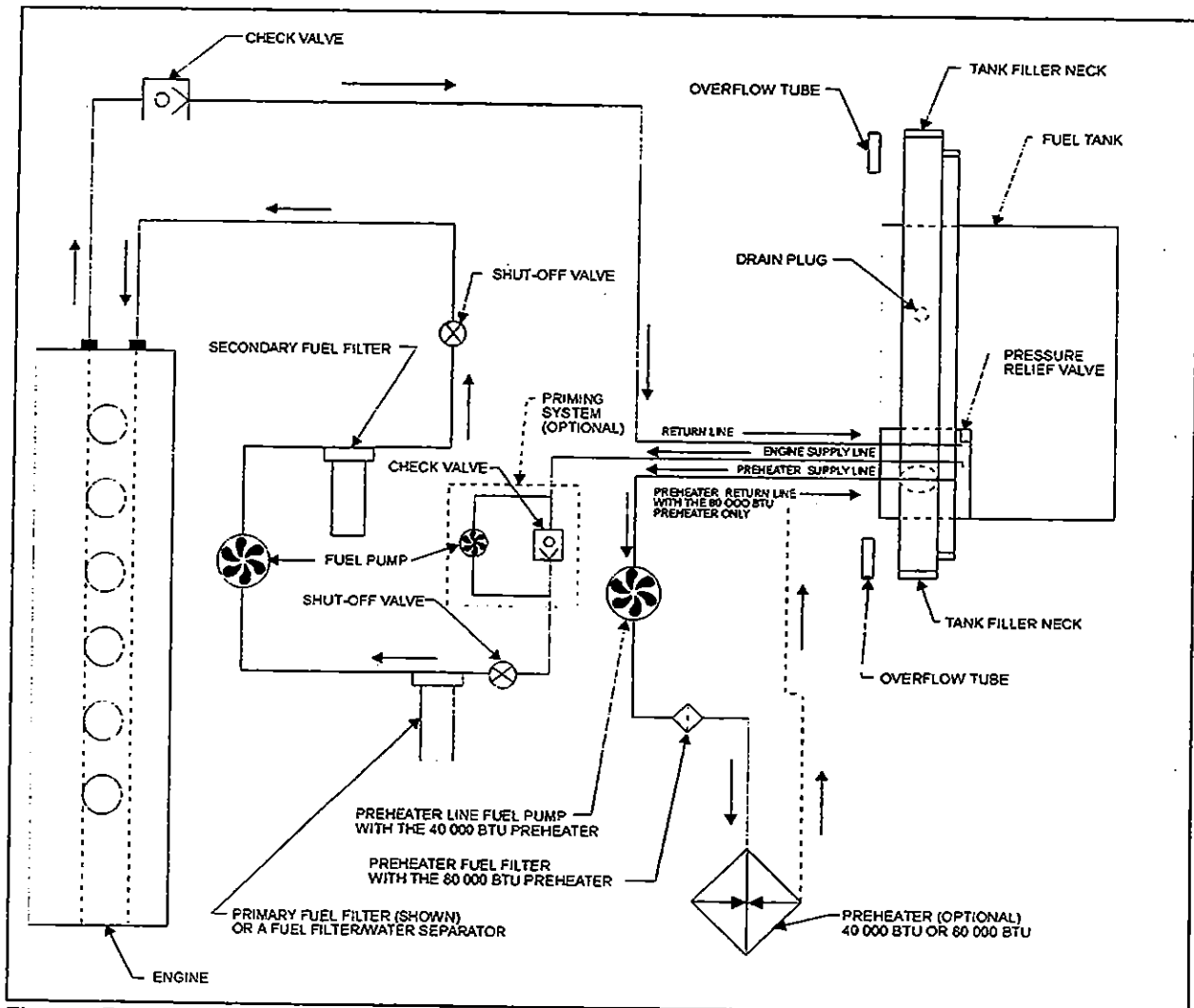

Figure1: Fuel System Schematic

03005

## 2. Fuel Lines and Flexible Hoses

Make a visual check for fuel leaks at all engine-mounted fuel lines and connections and at the fuel tank suction and return lines. Since fuel tanks are susceptible to road hazards, leaks in this area may best be detected by checking for accumulation of fuel under the tanks. Engine performance and auxiliary equipment is greatly dependent on the ability of flexible hoses to transfer lubricating oil, air, coolant and fuel oil. Diligent maintenance of hoses is an important step in ensuring efficient, economical and safe operation of engine and related equipment.

Check hoses daily as part of the pre-start-up inspection. Examine hoses for leaks and check all fittings, clamps and ties carefully. Make sure that the hoses are not resting on or touching shafts, couplings, heated surfaces, including exhaust manifolds, any sharp edges or other obviously hazardous areas. Since all machinery vibrates and moves to a certain extent, clamps and ties can fatigue with age. To ensure continued proper support, inspect fasteners frequently and tighten or replace them as necessary. Refer to the schematic diagram of the fuel system (Fig. 1).

**Caution:** Oil level above the dipstick full mark or a decrease in lube oil consumption may indicate internal fuel leaks. Check oil level frequently.

## 3. Fuel Valves

Manual shut-off valves on engine fuel supply line are located on the R.H. side of engine compartment (Fig. 2). A manual shut-off valve is located at the inlet side of the primary fuel filter (fuel filter/water separator, if vehicle is so equipped) under the air compressor. Another manual shut-off valve is located at the outlet side of the secondary fuel filter, under the starter. No manual valve is required on preheater fuel supply line, since the positive-displacement fuel pump (located close to the fuel tank) will shut off line when it is not activated.

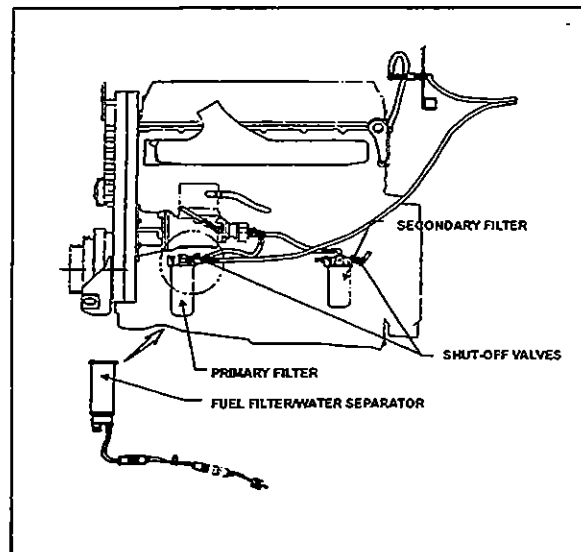

03006

Figure 1: Location of Manual Shut-off Valves

## 4. Filters and Water Separator

The fuel system is equipped with primary and secondary fuel filters for additional protection of the injectors. A fuel filter/water separator can be installed as an option. With this option, the primary filter is removed and it is replaced by the fuel filter/water separator (Fig. 2).

**Note:** The service intervals of the filter/water separator element and the secondary fuel filter cartridge are determined by the operating conditions and cleanliness of type of fuel used.

## 4.1 Fuel Filter/Water Separator Servicing

The fuel filter/water separator is located on the R.H. side of the engine compartment, on the engine below the air compressor. The water separator must be drained periodically or when the indicator light on the central dashboard panel is illuminated.

Replace the water separator element as follows.

1. Drain the fuel filter/water separator as stated previously.
2. With engine off and engine fuel supply line valves closed, remove the filter element from mounting head with bowl connected (see subject "3. Fuel Valves" of this section for valve location).
3. Remove bowl from filter element. Clean bowl and O-ring gland.

**Note:** *Bowl is reusable, do not discard.*

4. Lubricate O-ring with clean diesel fuel or motor oil and place it in bowl gland.

**Caution:** *Do not use tool to tighten bowl. Tighten by hand only.*

5. Spin bowl onto new filter element snugly by hand.
6. Lubricate filter to seal with clean diesel fuel or motor oil.
7. Fill filter element/bowl assembly with clean diesel fuel and attach onto mounting head. Hand tighten an additional 1/3 to 1/2 turn after full seal contact is made.
8. Open valves of the engine fuel supply line.
9. Run the engine and check for leaks.

**Caution:** *If the water separator continuously requires draining, it is possible that water or sediment is accumulated in the fuel tank. To correct this situation, open the drain plug under the tank when the fuel gauge indicates tank is 1/4 full in order to drain any contaminant.*

## 4.2 Fuel Filter Servicing (Primary and Secondary)

The primary and secondary fuel filters are located on the R.H. side of the engine compartment. The primary filter is installed on the engine below the air compressor. The secondary fuel filter is also installed on the engine but below the starter. They are of a spin-on type and must be replaced every 12,000 miles (20 000 km) or once a year, whichever comes first.

A method of determining when filters are plugged to the extent that they should be changed is based on the fuel pressure at the cylinder head fuel inlet fitting and the inlet restriction at the fuel pump. In a clean system, the maximum pump inlet restriction should not exceed 6 inches of mercury (20.3 kPa) and must not exceed 12 inches of mercury (41 kPa) with a dirty system.

At normal operating speeds and with the standard 0.080" restriction fittings, the fuel pressure at the cylinder head inlet is 50-75 psi (345-577 kPa). Change the fuel filters whenever the inlet restriction at the fuel pump reaches 12 inches of mercury (42 kPa) at normal operating speeds and whenever the fuel pressure at the cylinder head inlet fitting falls to the minimum fuel pressure given above.

Change the filter cartridge(s) as follows.

**Note:** *Use a suitable band wrench or filter wrench, such as J22775, to remove the filters.*

1. Stop engine, shut off the engine fuel supply line valves (See "3. Fuel Valves" for valve location). Unscrew and discard filters.

2. Fill new filter replacement cartridge(s) with clean fuel oil, about two thirds (2/3). Apply a thin coat of clean fuel oil on gasket.
3. Install new filters. Tighten until filter is snug against the gasket, with no side movement. Rotate an additional 1/2 turn by hand.
4. Open engine fuel supply line valves.

**Caution:** Mechanical tightening of the fuel filters is not recommended and may result in seal and/or cartridge damage. Tighten the fuel filters by hand only.

5. Start the engine and check for leaks.

**Note:** There is a fuel system shut-off valve on the discharge side of the secondary fuel filter. This check valve is designed to prevent loss of fuel at time of filter replacement.

### 4.3 Preheater Fuel Filter

The preheater fuel filter is installed on the vehicle only with the optional 80 00 BTU preheater. The filter is located in the rear electric compartment. Replace the filter every 50,000 miles (80 000 km) or once a year, whichever comes first.

## 5. FUEL TANK

The vehicle is equipped with a welded stainless steel fuel tank with a capacity of 230 US gal (871 liters). The tank is located next to the last baggage compartment, between condenser and HVAC unit compartments (Heating, Ventilation and Air Conditioning).

Dual filler necks are provided to refuel from either side of vehicle; the left side fuel filler neck is accessible through a fuel filling access door, while access to the right filler neck is possible through the refrigerant dryer access door (see "Operator's Manual" for details).

A pressure relief valve in the tank relieves high pressure buildup, and an air vent allows offset air in the tank to escape during filling. A drain plug, accessible from under the vehicle, is fitted at the bottom of the tank.

### 5.1 Tank Removal/Installation

**Note:** Prior to removal, the fuel tank should be completely drained by unscrewing the drain plug. Ensure that the container used has a capacity equal to the amount of fuel remaining in the tank.

1. Open the condenser door (refer to "Operator's Manual" for details). Remove the fuel access panel. Locate the fuel tank line connections (Fig. 3).
2. Unscrew the fuel engine return line, engine supply line fittings and the air vent clamps. If applicable, unscrew the preheater supply line and the preheater return line clamps.

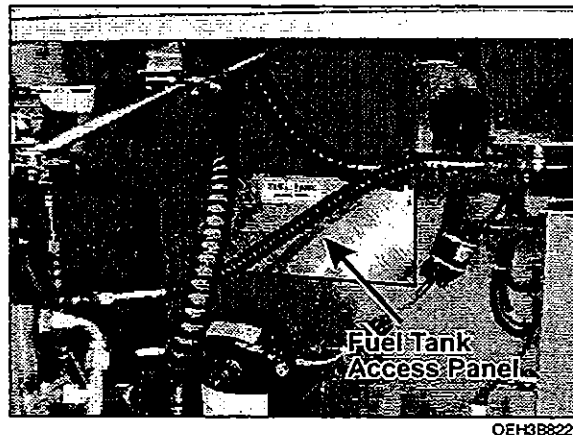

Figure 2: Fuel Tank Access Panel Location

3. Disconnect all fuel and air vent lines, alarms and fuel gauge connectors.
4. Unscrew the fuel tank filler neck tube clamps. Disconnect tubes.

## Section 03: FUEL SYSTEM

**Warning:** Before removing the bolts securing the tank to the frame, make sure that the tank is supported adequately. Failure to do so could result in injury as well as damage to the tank.

5. From under the vehicle, on the R.H. side, unscrew the four bolts (two on each side) retaining the tank support to the frame bracket.
6. From under the vehicle, on the L.H. side, unscrew the six bolts (three on each side) retaining the tank support to the frame bracket. Remove the two mounting plates located between the tank support and frame brackets. Carefully remove tank from under the vehicle.
7. Installation is the reverse of removal.

## 6. PRIMING FUEL SYSTEM

The problem with restarting an engine that has run out of fuel, is that after the fuel is exhausted from the tank, it is pumped from the primary fuel filter or the fuel filter/water separator, if vehicle is so equipped, and sometimes partially removed from the secondary filter resulting in an insufficient fuel supply to sustain engine firing. The primary fuel filter or fuel filter/water separator and secondary filter must be free of air in order for the systems to provide adequate fuel for the injectors. When the engine runs out of fuel, the following operations must be performed before restarting.

Fill fuel tank with the recommended fuel oil. If only partial filling is possible, add a minimum of 10 gallons (38 liters) of fuel.

If the vehicle may be prime equipped with an optional priming pump (see Fig. 1).

Start the priming pump. The switch is located in the engine compartment and mounted on a small box above the engine (between the starter button and the starter selector switch). Start the engine and check for leaks.

If the vehicle is not equipped with a priming pump.

1. Unscrew the cap on the priming valve located on the secondary filter.
2. Direct fuel under pressure 25 psi (172 kPa) to the priming valve using a quick coupling.
3. Start the engine and check for leaks.

## 7. FUEL PUMP INSTALLATION

The fuel pump is attached to a drive assembly mounted on the rear side of the gear case.

1. If removed, install inlet and outlet fittings in the cover of the fuel pump.

**Note:** New fittings have sealant already applied. If reusing fittings, coat the threads lightly with Loctite Pipe Sealant, Detroit Diesel number J 26558-92, or equivalent, before installing. To prevent sealant from entering fuel system, do not apply it to the first two (2) threads of the fitting. Do not use teflon tape or paste on the fittings.

2. Install drive coupling in drive hub of the fuel pump. Install a new gasket to the mounting flange of the pump.
3. Align the drive coupling with the coupling on the fuel pump drive assembly pump mounting bolt holes with those in the fuel pump drive assembly.
4. Seat the pump squarely against the drive assembly. Install three (3) fuel pump mounting bolts and tighten them to 22-28 lbf·ft (30-38 N·m).
5. Connect the fuel inlet and outlet lines to the fuel pump and tighten.
6. Prime engine fuel system before starting engine to ensure pump seal lubrication and prompt engine starting.



## 8. FUEL OIL SPECIFICATIONS

The quality of fuel oil used for high speed diesel engine operation is a very important factor in obtaining satisfactory engine performance, long engine life and acceptable exhaust emission levels. The fuel oil should meet ASTM designation D 975. Grade 1-D is recommended, but grade 2-D is also acceptable.

**Note:** *These fuel grades are very similar to grade DF-1 or DF-2 of Federal Specifications VV-F-800. For detailed fuel recommendations, refer to publication "Engine Requirements-Lubricating Oil, Fuel, and Filters" #7SE270 available from Detroit Diesel Distributors.*

## 9. AIR CLEANER (dry type)

H3 vehicles are equipped with a two-stage, dry-type, replaceable element air cleaner, located in the engine compartment. To service the air cleaner, open the R.H. side engine compartment door. Engine air enters the air cleaner through an intake duct integrated to the R.H. side of the rear cap, next to the last window of vehicle, then flows through a pre-cleaner and finally through the air cleaner. The pre-cleaner removes dust and moisture from air and drains dust and moisture by means of a discharge tube at the bottom of the pre-cleaner. The pre-cleaner is in series with a replaceable impregnated paper filter element (air cleaner) (Fig. 4).

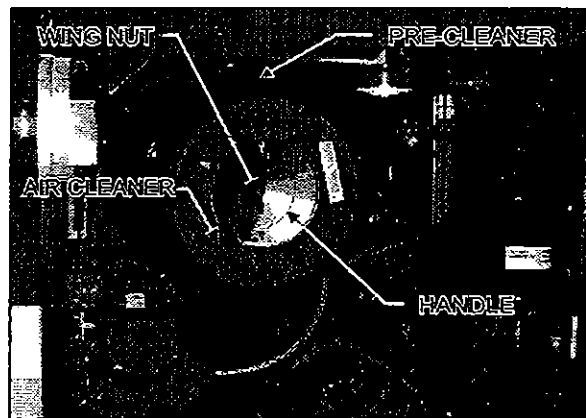

Figure 3 : Air Cleaner Location

03007

### 9.1 Pre-Cleaner Servicing

The pre-cleaner is designed to be self-cleaning; however, it should be inspected and any accumulated foreign material removed during the periodic replacement of the impregnated paper filter element.

### 9.2 Air Cleaner Servicing

Stop the engine, open the R.H. side engine compartment door, and loosen the wing nut retaining the air cleaner element to the air cleaner. Remove the element by pulling on the handle in the center of the air cleaner element.

Install cleaner element as follows:

1. Inspect the gasket sealing surface inside the air cleaner. It must be smooth, flat and clean.
2. Install the air cleaner element.
3. Make sure that the element seals securely.
4. Inspect element cover gasket and replace if necessary.

Whenever it becomes necessary to remove the air cleaner assembly (dry type) for maintenance or other repair in this area, great care should be taken when installing air cleaner assembly.

## Section 03: FUEL SYSTEM

The pre-filter should be installed snugly in the air duct and clamped tightly to the air cleaner inlet to prevent any dust infiltration into the air cleaner.

### 9.3 General Recommendations

The following maintenance procedures will ensure efficient air cleaner operation:

1. Keep the air cleaner housing tight on the air intake pipe.
2. Make sure the correct filters are used for replacement.
3. Keep the air cleaner properly assembled so the joints are air-tight.
4. Immediately repair any damage to the air cleaner or related parts.
5. Inspect, clean or replace the air cleaner or elements as operating conditions warrant. Whenever an element has been removed from the air cleaner housing the inside surface of the housing must be cleaned with a soft clean cloth.
6. Periodically inspect the entire system. Dust-laden air can pass through an almost invisible crack or opening which may eventually cause damage to an engine.
7. Never operate the engine without an element in the air cleaner assembly.
8. Do not ignore the warning given by the air restriction indicator. This could result in serious engine damage.
9. Store new elements in a closed area free from dust and possible damage.

### 9.4 Air Cleaner Restriction Indicator

A resettable restriction indicator is installed on the engine air intake duct near the turbocharger in the engine compartment, to constantly monitor the level of vacuum between the air cleaner and engine in order to detect and indicate an abnormal increase in vacuum due to a dirt-laden and therefore restricted air cleaner element.

When the red signal flag locks in full view, the air cleaner element must be inspected and replaced if necessary. The indicator flag must be reset by pressing on its extremity (Fig. 5).

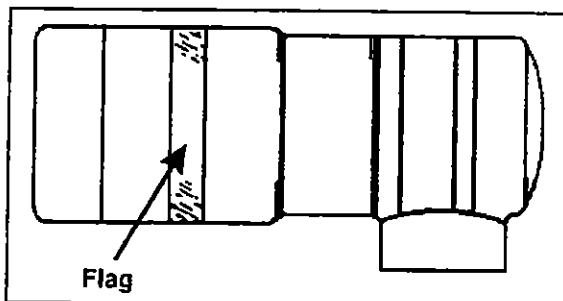

Figure 5: Air Cleaner Restriction Indicator OEH3B744

## 10. SPECIFICATIONS

### Primary/Water Separator (optional)

May be used instead in place of the primary filter (never use with a primary filter).

Make ..... Racor  
 Type ..... Spin-on  
 Supplier number ..... S 3202  
 Prevost number ..... 53-1390

### Primary Fuel Filter

Make ..... AC  
 Type ..... Spin-on  
 Filter No. .... T-915D  
 Service Part No. .... 25014274  
 Fuel filter Prevost number ..... 51-0137  
 Element torque ..... 1/2 turn after gasket contact

### Secondary Fuel Filter

Make ..... AC  
 Type ..... Spin-on  
 Filter No. .... T-916D  
 Service Part No. .... 25014342  
 Fuel filter Prevost number ..... 51-0128  
 Element torque ..... 1/2 turn after gasket contact

### Fuel tank

Capacity ..... 230 US gal (871 liters)

### Air Cleaner

Make ..... Nelson  
 Prevost Number ..... 53-0206  
 Element cartridge supplier number ..... 70337-N  
 Element cartridge Prevost number ..... 53-0197

### Pre-Cleaner

Pre-cleaner Prevost number ..... 53-0207  
 Make ..... Donaldson  
 Model ..... PVH001220

### Air Restriction Indicator

Make ..... Donaldson  
 Model ..... RAX00-2320  
 Indicates ..... at 20" (508 mm) of water  
 Prevost number ..... 53-0161

### Preheater Fuel Filter (40 000 BTU)

Make ..... Webasto  
 Supplier number ..... 603.359  
 Prevost number ..... 87-1037

### Preheater Line Fuel Pump

Supplier number ..... 25-1571-45-0000  
 Prevost number ..... 87-0973

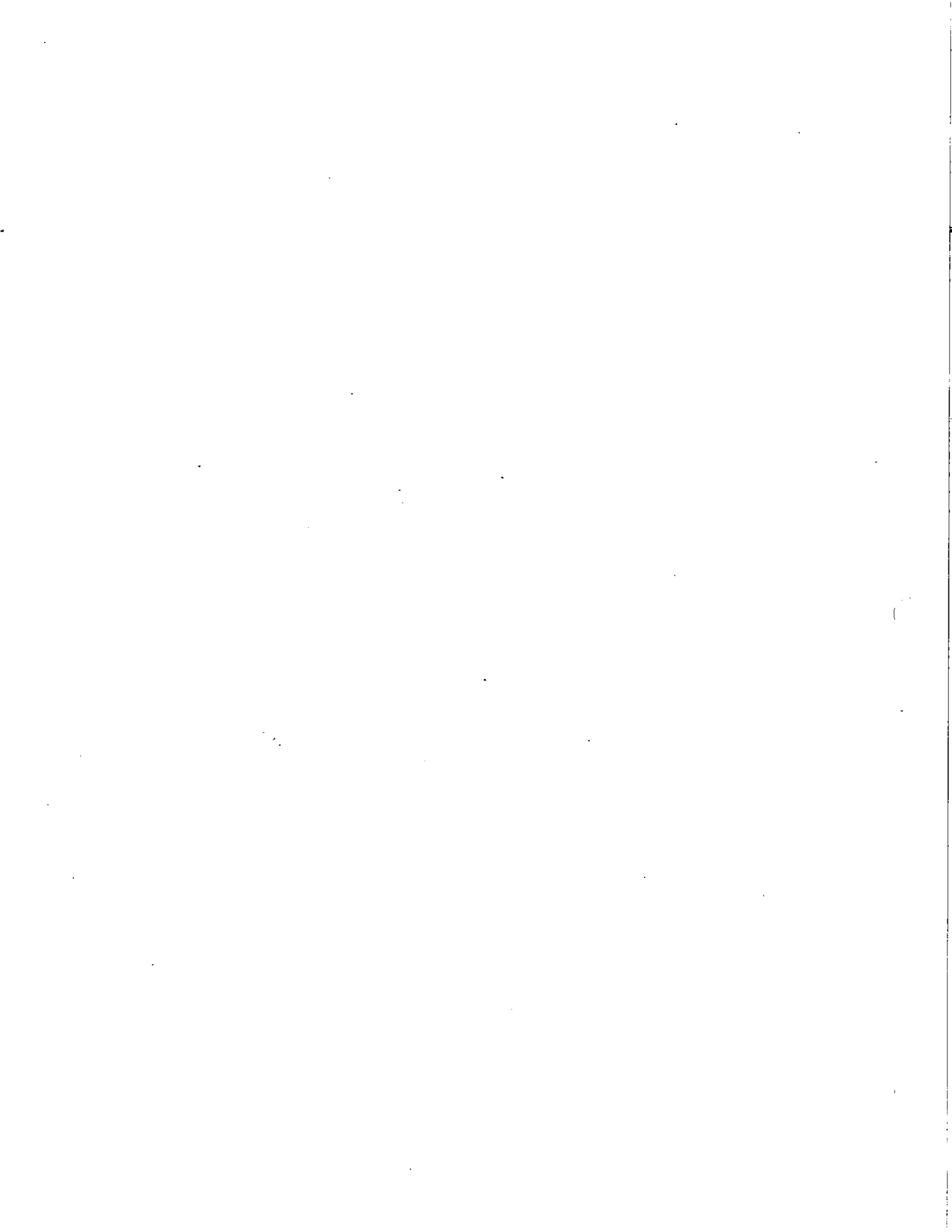



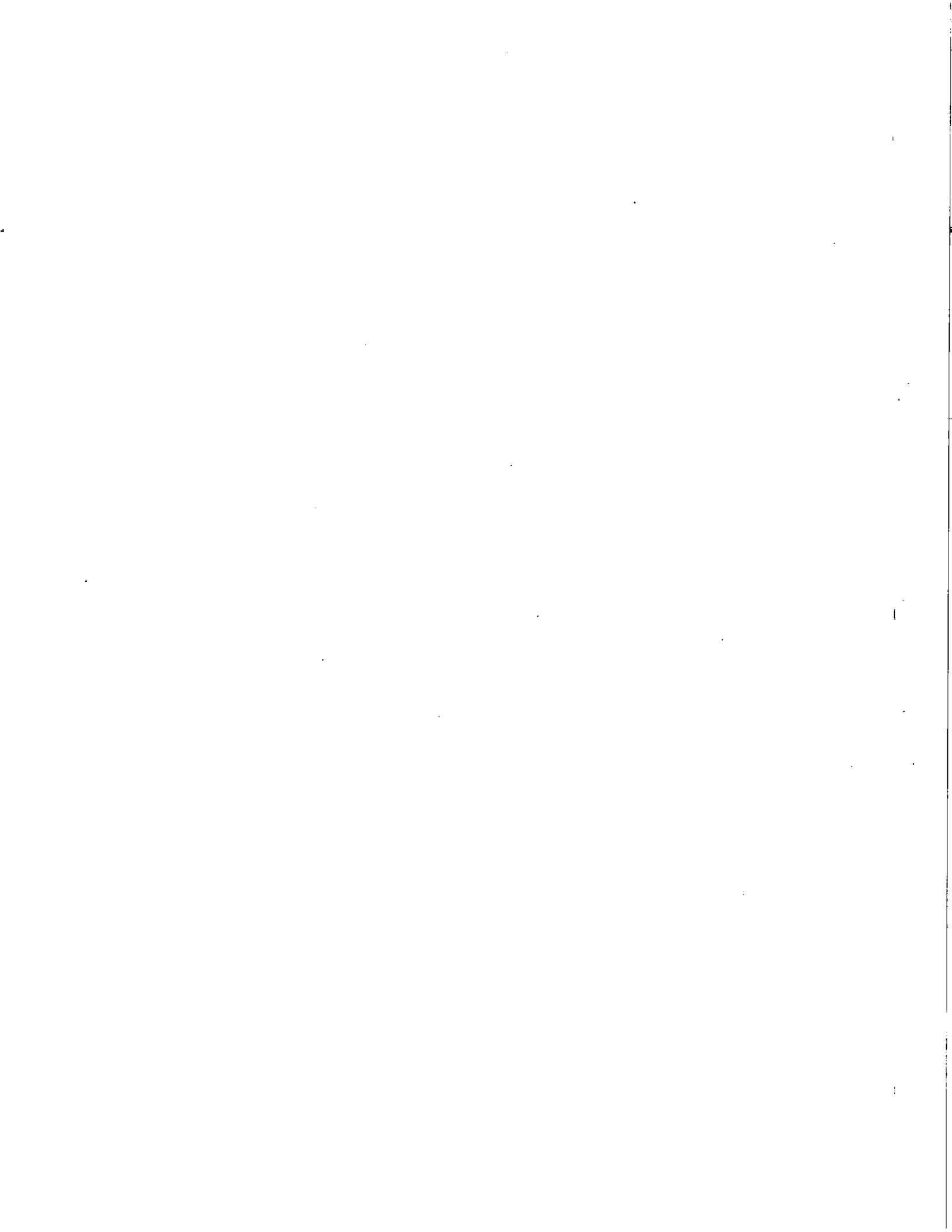

# SPIN-ON FILTER/SEPARATORS

THE RACOR 20 SERIES SPIN-ON FUEL FILTER-WATER SEPARATORS CAN SOLVE DIESEL FUEL PROBLEMS UNDER ANY OPERATING CONDITIONS IN THE WORLD.

## Advanced Filtration/ Separation Technology

The unique design of the 20 Series directs the fuel flow to the expanded center core of the unit. The reduced velocity causes heavy liquid and solid contaminants to accumulate in the inner chamber of the filter/separator bowl. Then they are drained off through a positive seal drain valve. This primary separation or pre-cleaning stage gives extended element life.

The 20 Series Filter/Separator units are compact and easy to service.

## Vacuum (Suction) Applications

The *Dual Media Replacement Filter Element* uses a new Racor two-stage process of Dual Phase Repelling Action and Dual Phase Filtration to remove virtually 100% of the remaining free water and damaging solid particulate contaminants from diesel fuel. Primer pump, vent cap and check valve are standard.

## Pressure Applications

The *Multi-Media Coalescer Replacement Filter Element* is for pressure side installations where the fuel has passed through a transfer pump and a coalescing filtration action is necessary for a high degree of water removal effectiveness. With the coalescer replacement filter element, 99+ % of free and emulsified water and damaging solid particulate contaminants are removed. Vent cap is standard.

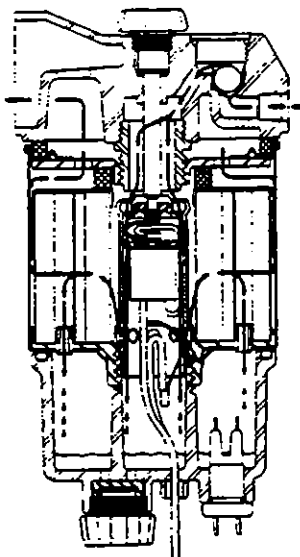

## Options

- Electrical in-filter heater
- Metal Bowl
- Service Indicator Package (water sensor and element change monitor)



### 220

Height 8" (203 mm)  
Width 4" (102 mm)  
Depth 4" (102 mm)  
Max. Flow Rate 30 gph (114 lph)  
Weight 1.75 lbs. (.79 kgs.)

Element Model No.	R24 Dual Media	C25 Coalescer
Dirt Capacity (Soft C-2A)	80 gms	75 gms
Dirt Removal Rating	96% at 2 micron w/A.C.F.T.D.	
Water Removal Efficiency Effluent:	less than 10ppm free water	less than 30ppm free water

### 225

Height 9.5" (241 mm)  
Width 4" (102 mm)  
Depth 4" (102 mm)  
Max. Flow Rate .45 gph (170 lph)  
Weight 2 lbs. (.90 kgs.)

Element Model No.	R26 Dual Media	C27 Coalescer
Dirt Capacity (Soft C-2A)	117 gms.	107 gms
Dirt Removal Rating	96% at 2 micron w/A.C.F.T.D.	
Water Removal Efficiency Effluent:	less than 10ppm free water	less than 30ppm free water

# FUEL ADDITIVES

Racor additives are specially formulated to be completely compatible with engines, fuel filters and water separators. They contain no damaging alcohol and keep fuel in the best possible condition for all diesel engine applications.

**SUPER CONCENTRATED.**  
COMPARE TREATMENT COST PER GALLON OF FUEL.

## Racor RX-100 Cold Weather Diesel Additive

- Contains a pour point depressant fuel conditioner
- Keeps fuel flowing down to -40°F (-40°C).
- Improves engine performance reduces engine wear
- Eases starting, aids combustion, prevents corrosion
- Eliminates waxing and clogged filters

- Cleans fuel lines, pumps and injectors

Part No.	Type	Size	Treatment
11-1179	RX-100	10 oz.	15-30 Gallons
11-1180	RX-100	32 oz.	150-200 Gallons
11-1181	RX-100	1 gal.	1,000 Gallons
11-1284	RX-100	2.5 gal.	5,000 Gallons
11-1285	RX-100	20 gal.	55,000 Gallons

**Racor RX-200  
Diesel Treatment**

- Improves engine performance
- Cleans fuel lines, pumps and injectors
- Eases starting and prevents corrosion

Part No.	Type	Size	Treatment
11-1270	RX-200	10 oz	One 10 oz Can Per Tankful
11-1274	RX-200	32 oz.	150-200 Gallons

**Racor RX-300  
Marine Diesel Treatment**

Formulated for diesel fuel in a marine environment, RX-300—

- Contains a biocide and fuel conditioner
- Prevents fungi, bacteria and algae growth
- Cleans fuel lines, pumps and injectors
- Improves engine performance
- Provides rust protection and lubrication throughout the entire system

Part No.	Type	Size	Treatment
11-1266	RX-300	10 oz.	50 Gallons
11-1267	RX-300	32 oz.	500 Gallons
11-1268	RX-300	1 gal.	5,000 Gallons
11-1269	RX-300	20 gal.	100,000 Gallons

**BUTT SPLICE  
Installation Instructions**

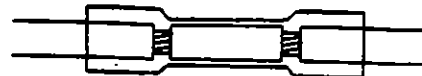

1. Select splice of appropriate size. Strip wires 0.3". Insert into crimp barrel.



2. Crimp using crimp tool for preinsulated crimps.



3. Heat splice with heat gun until tubing recovers and adhesive flows.

**RACOR LIMITED WARRANTIES STATEMENT**

All products manufactured or distributed by Racor are subject to the following, and only the following, LIMITED EXPRESS WARRANTIES, and no others:

For a period of one (1) year from and after the date of purchase of a new Racor product, Racor warrants and guarantees only to the original purchaser-user that such a product shall be free from defects of materials and workmanship in the manufacturing process. The warranty period for pumps and motors is specifically limited to ninety (90) days from date of purchase. A product claimed to be defective must be returned to the place of purchase. Racor, at its sole option, shall replace the defective product with a comparable new product or repair the defective product. This express warranty shall be inapplicable to any product not properly installed and properly used by the purchaser-user or to any product damaged or impaired by external forces. THIS IS THE EXTENT OF WARRANTIES AVAILABLE ON THIS PRODUCT. RACOR SHALL HAVE NO LIABILITY WHATSOEVER FOR CONSEQUENTIAL DAMAGES FLOWING FROM THE USE OF ANY DEFECTIVE PRODUCT OR BY REASON OF THE FAILURE OF ANY PRODUCT. RACOR SPECIFICALLY DISAVOWS ALL OTHER WARRANTIES, EXPRESS OR IMPLIED INCLUDING, WITHOUT LIMITATION, ALL WARRANTIES OF FITNESS FOR A PARTICULAR PURPOSE (EXCEPT FOR THOSE WHICH APPLY TO PRODUCT OR PART THEREOF THAT IS USED OR BOUGHT FOR USE PRIMARILY FOR PERSONAL, FAMILY, OR HOUSEHOLD PURPOSES), WARRANTIES OF DESCRIPTION, WARRANTIES OF MERCHANTABILITY, TRADE USAGE OR WARRANTIES OF TRADE USAGE.

Parker Hannifin Corporation  
Racor Division  
P.O. Box 3206  
Modesto, CA 95353 USA  
800/344-3286, 209/521-7860  
Telex 359-408 RACOR MSTO

For the name of the Racor distributor nearest you, call 1-800-344-3286  
In Alaska, California and Hawaii, call 1-209-521-7860

INSTALLATION INSTRUCTIONS  
Racor Part No. 7091FG  
9-90/24M





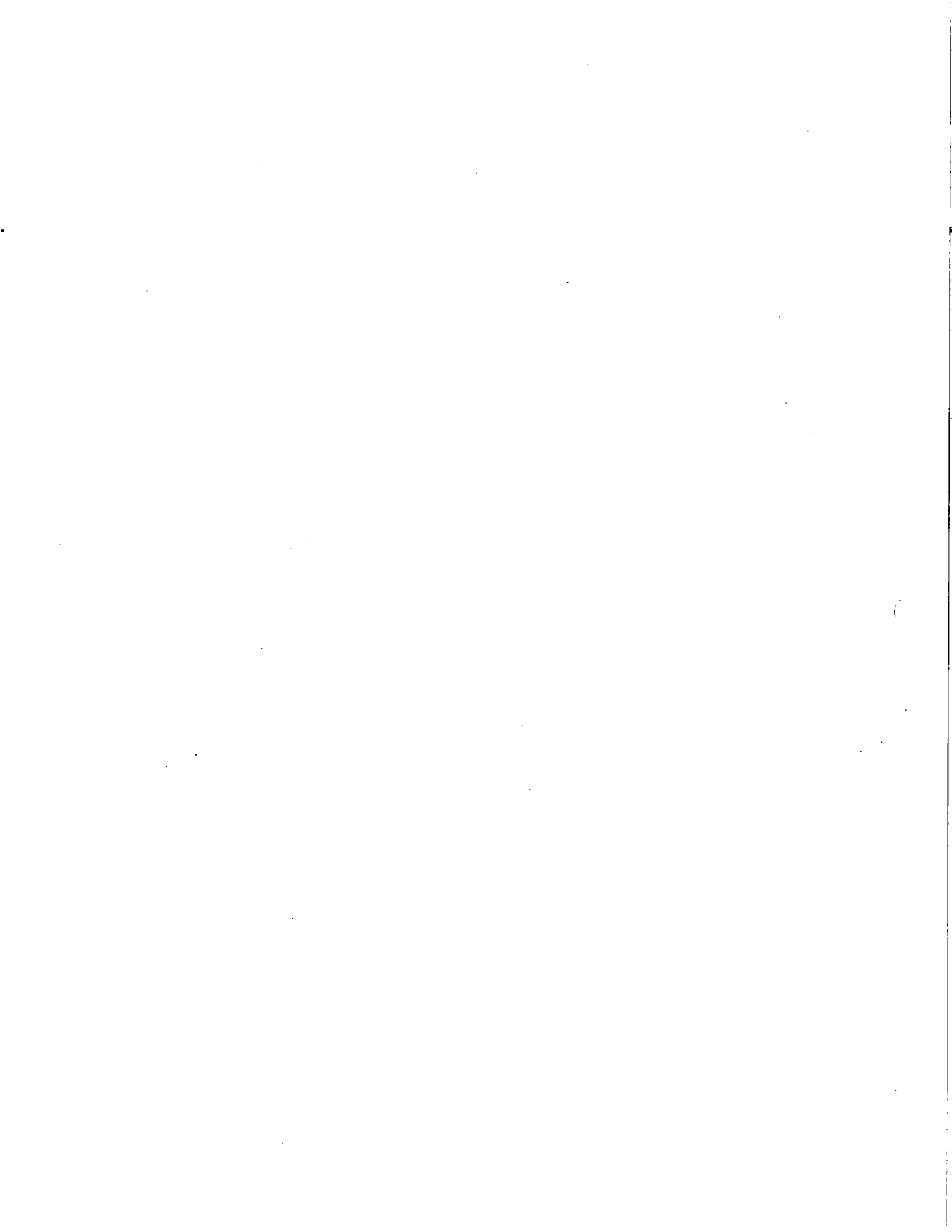

# SECTION 04: EXHAUST SYSTEM

---

## CONTENTS

1. MAINTENANCE .....	2
2. MUFFLER REMOVAL/INSTALLATION .....	3
3. FLEXIBLE TUBE INSTALLATION.....	3

## 1. MAINTENANCE

The exhaust system should be inspected periodically for restrictions and leaks. The exhaust system is shown in figure 1. Restrictions such as kinked or crimped pipes result in excessive back pressure which can lead to increased fuel consumption, power loss, and possible damage to engine combustion chamber components. Exhaust leaks are commonly the result of loose clamp bolts, corroded pipes, or a punctured muffler. In addition to excessive noise, a leaking exhaust system could allow toxic gases to enter the vehicle. Inspect the exhaust system as follows:

- At vehicle inspection intervals;
- Whenever a change is noticed in the sound of the exhaust system; and
- Whenever the exhaust system is damaged.

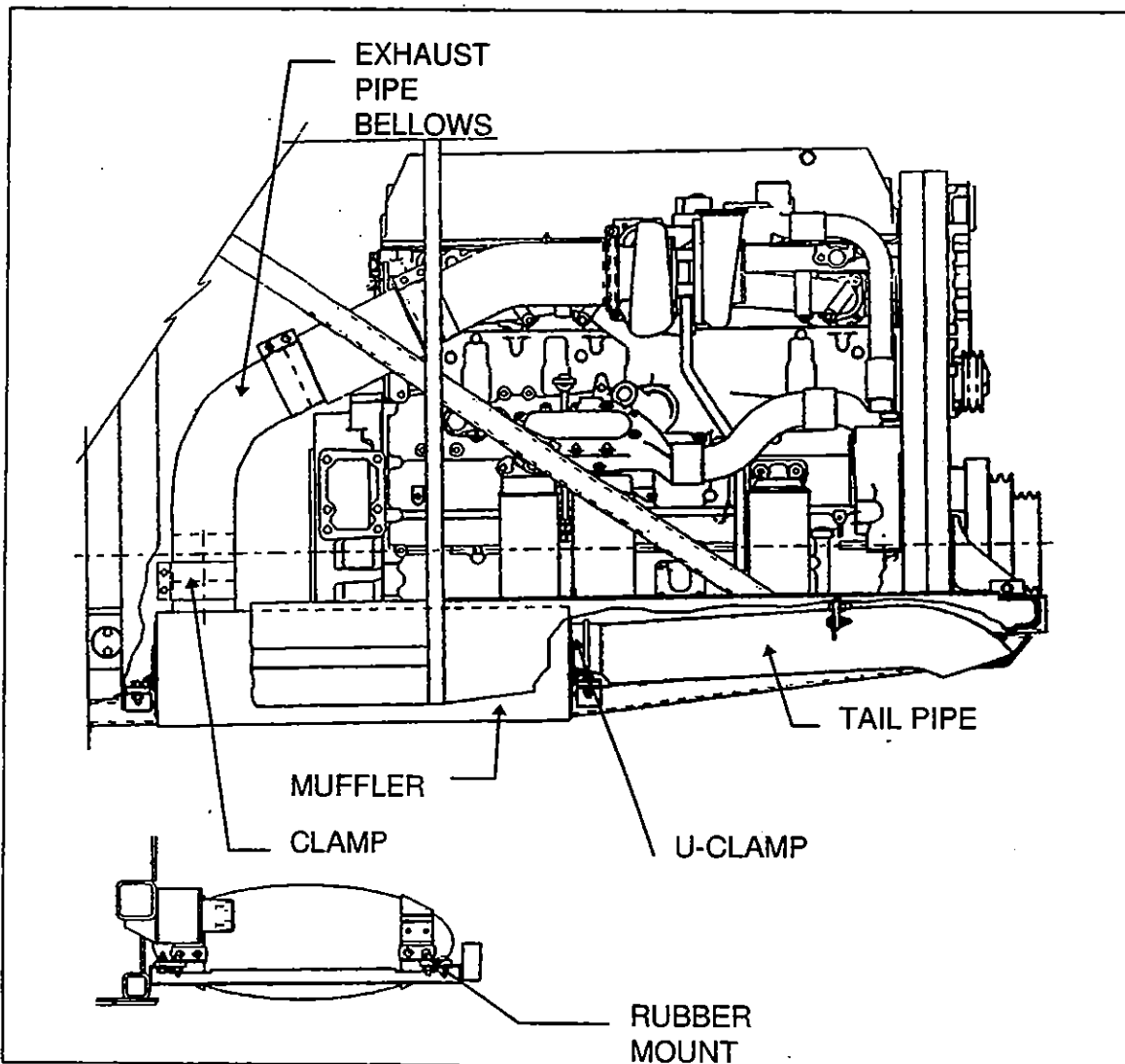

Figure 1: Exhaust System

04001

Replace damaged or corroded exhaust system components without delay.

When operating the engine in a service garage or in a closed area, the exhaust must be vented to the outside. Place the shop vent hose over the exhaust outlet pipe.

**Warning:** *Avoid breathing exhaust gases. Exhaust contains carbon monoxide which is odorless and colorless. Carbon monoxide is a dangerous gas which can cause unconsciousness and can be lethal. If at any time you suspect that exhaust fumes are entering the vehicle, locate and correct the cause(s) as soon as possible.*

## 2. MUFFLER REMOVAL/INSTALLATION

**Warning:** *Make sure the that muffler and components are cold before removing or installing components.*

1. Remove bolts and clamps securing exhaust pipe bellows to the muffler.
2. Support the muffler from under the vehicle.
3. Remove U-clamp which retains the tail pipe to the muffler.
4. Remove bolt holding the tail pipe to the frame bracket.
5. Remove the tail pipe.
6. Remove the fasteners holding the four rubber mounts to the frame brackets. Remove the fasteners securing the rubber mounts to the muffler brackets.

**Note:** *The front retaining bolts are accessible from the L.H. side tag axle wheel housing.*

7. Remove rubber mounts. Lower muffler from under vehicle.

8. Remove parts which are attached to the muffler such as brackets and collar. Inspect and replace pieces if necessary. Reinstall parts on the new muffler.
9. Installation is the reverse of removal.

## 3. FLEXIBLE TUBE INSTALLATION

The flexible exhaust tube contains an inside rigid pipe. To allow appropriate flexibility for assembly, make sure that the rigid pipe is concentric to the flexible part. To maintain the pipe centered at the time of installation, cardboard spacers must be inserted at four places at equal distance around it (Fig. 2). These spacers may be left in place and will deteriorate over time.

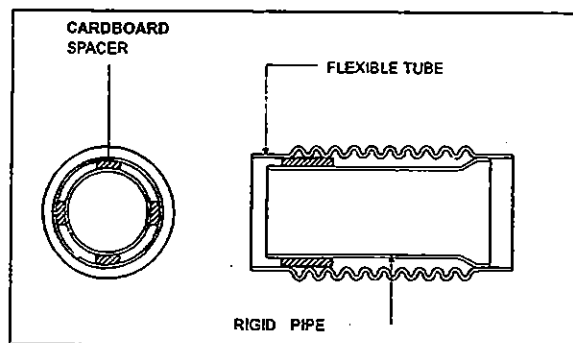
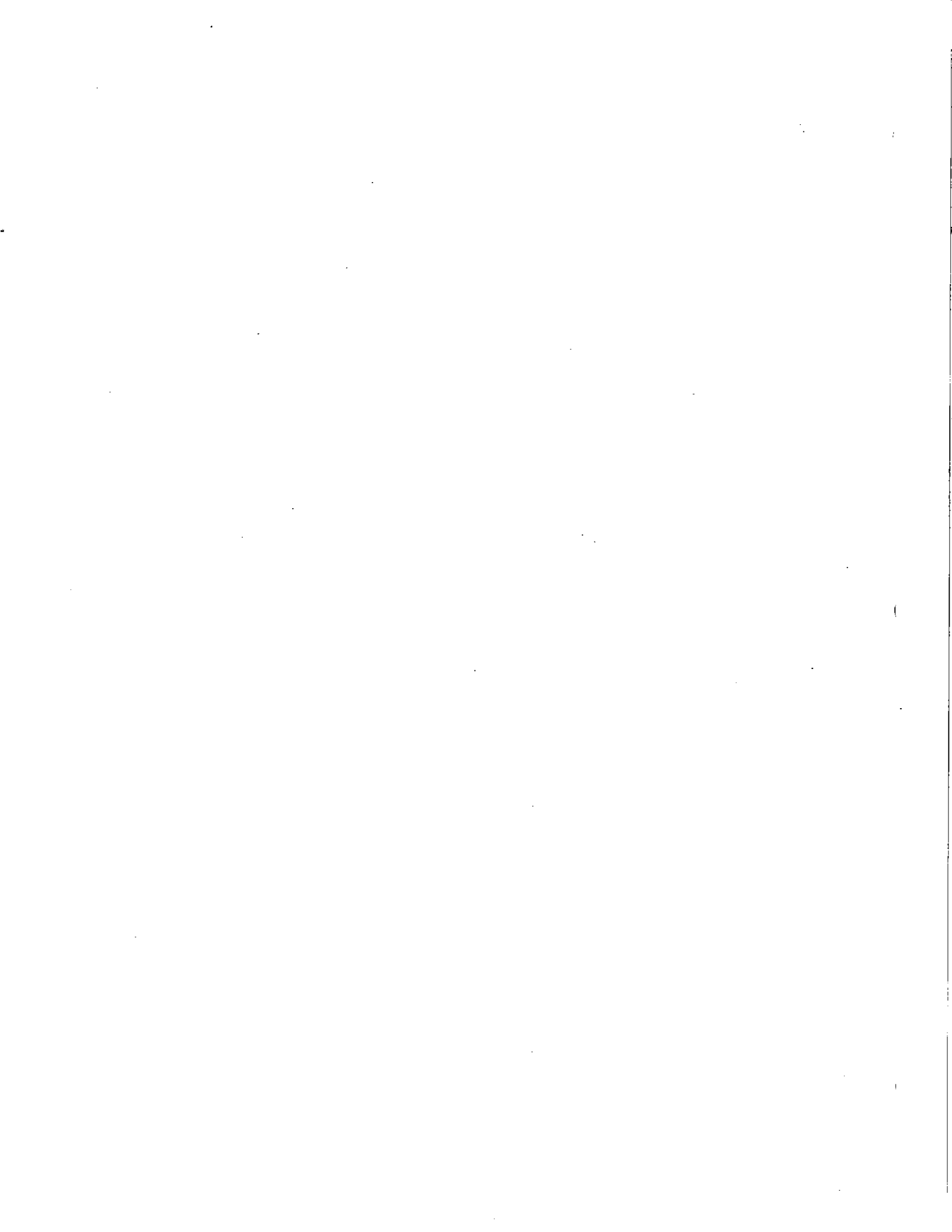

Figure 2: Flexible Tube Installation

04003



# SECTION 05: COOLING SYSTEM

---

## CONTENTS

1. COOLING SYSTEM.....	2
1.1 Description.....	2
1.2 Maintenance .....	3
2. HOSE.....	4
2.1 Inspection.....	4
3. CONSTANT-TORQUE HOSE CLAMPS.....	5
3.1 Description.....	5
3.2 Installation.....	5
3.3 Maintenance .....	5
4. COOLANT.....	5
4.1 Thawing Cooling System.....	5
4.2 Coolant Level Verification.....	5
4.3 Cooling Level Sensor .....	6
4.4 Coolant Requirements.....	6
4.5 General Cooling System Recommendations.....	6
4.6 Coolant Recommendations .....	7
4.7 Draining Cooling System.....	7
4.8 Refilling Cooling System.....	9
4.9 Flushing .....	10
4.10 Cooling System Cleaners.....	10
4.11 Reverse Flushing.....	10
5. COOLANT FILTER (SPIN-ON TYPE).....	11
5.1 Description.....	11
6. RADIATOR.....	12
6.1 Maintenance .....	12
7. RADIATOR VARIABLE SPEED FAN.....	12
7.1 Description.....	12
7.2 Maintenance .....	12
7.3 Inspection.....	13
7.4 Thermostat Operation.....	13
8. FAN GEARBOX.....	13
8.1 Description .....	13
8.2 Maintenance .....	13
8.3 Oil Change.....	14
9. RADIATOR FAN BELT REPLACEMENT AND AIR BELLOW TENSIONER.....	14
10. FAN DRIVE ALIGNMENT.....	14
11. SPECIFICATIONS .....	17

# 1. COOLING SYSTEM

## 1.1 Description

A radiator and thermo-modulated fan are used to effectively dissipate the heat generated by the engine. A centrifugal-type water pump is used to circulate the engine coolant (Fig.1).

Two full blocking-type thermostats are used in the water outlet passage to control the flow of coolant, providing fast engine warm-up and regulating coolant temperature.

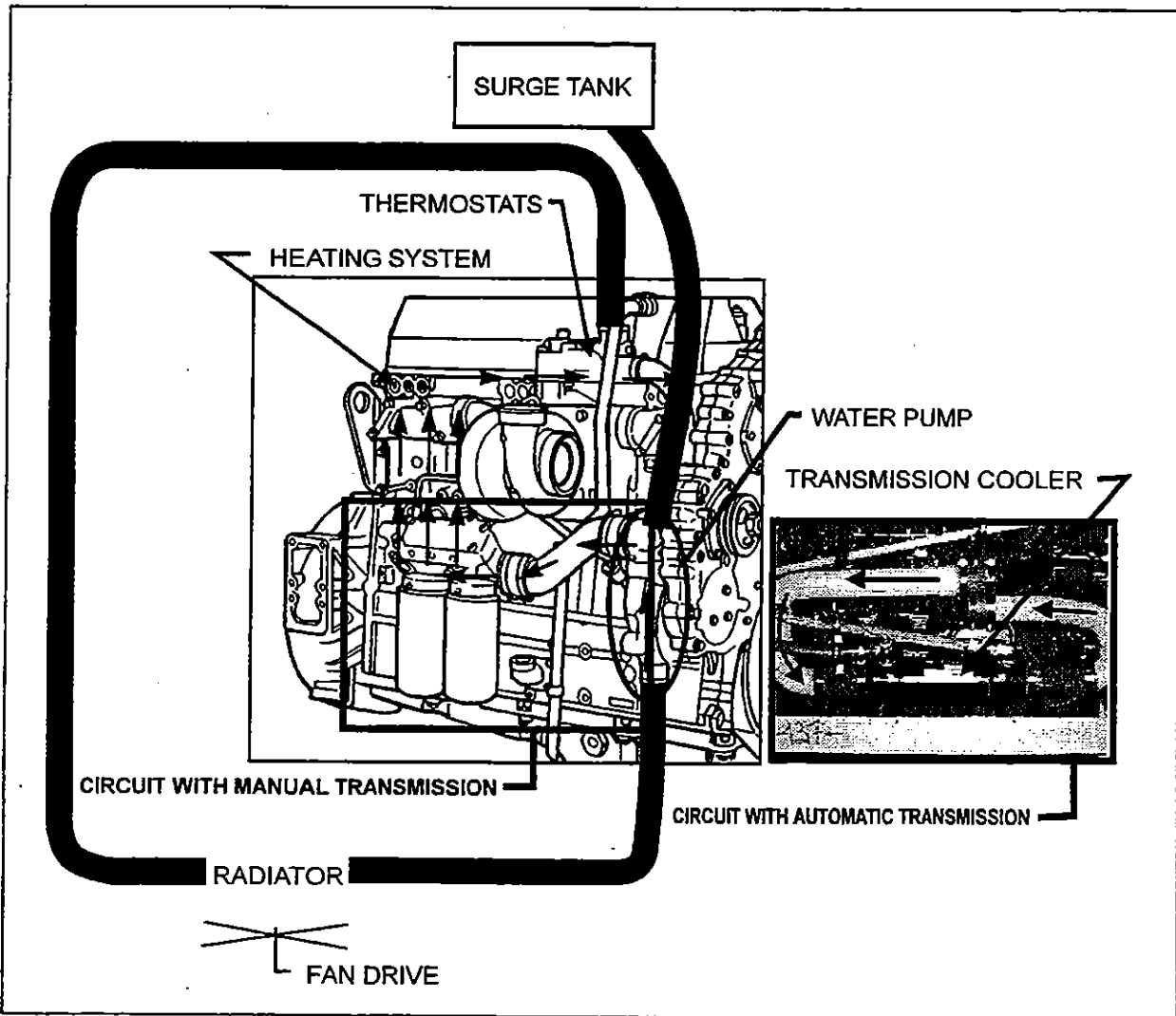

Figure 1: Cooling System

05023



The engine coolant is drawn from the lower portion of the radiator by the water pump and is forced through the oil cooler and into the cylinder block. For vehicles with automatic transmissions the coolant circulates in the transmission cooler before going through the oil cooler and the cylinder block.

From the cylinder block, the coolant passes up through the cylinder head when the engine is at normal operating temperature, through the thermostat housing and into the upper portion of the radiator. Then the coolant passes through a series of tubes where the coolant temperature is lowered by air streams created by the revolving fan and the motion of the vehicle.

Upon starting a cold engine, or when the coolant is below operating temperature, the closed thermostats direct coolant flow from the thermostat housing through the by-pass tube to the water pump. Coolant is recirculated through the engine to aid engine warm-up. When the thermostat opening temperature is reached, coolant flow is divided between the radiator inlet and the by-pass tube. When the thermostats are completely open, all of the coolant flow is to the radiator inlet.

The cooling system is filled through a filler cap on the surge tank (Fig. 2). A pressure cap at right of surge tank is used to maintain pressure within the system. When the system exceeds normal pressure rating (14 psi - 96.53 kPa), the cap releases air and if necessary, coolant through the overflow tube. Two thermostats are located in the housings attached to the right side of the cylinder head.

A water temperature sensor mounted on the cylinder head (radiator side) is also supplied for engine protection purposes.

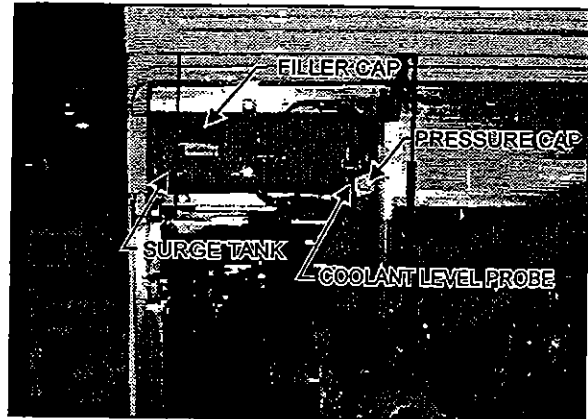

Figure 2: Cooling System Surge Tank

05024

The engine cooling system is also used to provide hot coolant for the vehicle heating system. Refer to Section 22, Heating and Air for information relating to heating system water circulation. Inspect cooling system as follows:

## 1.2 Maintenance

A systematic routine inspection of cooling system components is essential to ensure maximum engine and heating system efficiency.

- Check coolant level in the surge tank daily, and correct if required. Test antifreeze strength.
- Maintain the prescribed inhibitor strength levels as required. Coolant and inhibitor concentration must be checked at each oil change, every 12,500 miles (20 000 km) or once a year, whichever comes first to ensure inhibitor strength. For vehicles equipped with coolant filter, replace precharge element filter with a maintenance element filter. If the vehicle is not equipped with the filter, add the recommended inhibitor concentration to the antifreeze/water solution.

## Section 05 : COOLING SYSTEM

---

- Drain, flush, thoroughly cleaned and refill the system every two years or every 200,000 miles (320 000 km), whichever comes first. For vehicles equipped with coolant filter, change the precharge element filter or the existing maintenance element filter for a new maintenance element filter. If the vehicle is not equipped with the filter, add the recommended inhibitor concentration to the antifreeze/water solution.

**Note:** Do not add inhibitors to the antifreeze/water solution when vehicle is equipped with a coolant filter.

**Note:** The coolant must be discarded in a environmentally safe manner.

### Vehicles without coolant filter.

Refer to Nalcool 3000 with Stabil-Aid bulletin annexed to the end of this section for preventive maintenance (at each oil change) and initial treatment instructions (each time the cooling system is drained, flushed and cleaned).

### Vehicles with coolant filter.

Change the coolant precharge element filter for a maintenance element filter at each oil change (see specifications at the end of this section) and replace existing maintenance filter with a new one . Use a coolant precharge filter each time the cooling system is drained, flushed and cleaned.

- Check belts for proper tension. Adjust as necessary. Replace any frayed or badly worn belts.
- Check radiator cores for leaks. Make sure the cores are not clogged with dirt or insects. To avoid damaging the fins, clean cores with a low pressure air hose. Steam clean if required.
- Inspect the water pump operation. A leaky pump sucks in air, increasing corrosion.

- Repair all leaks promptly. Unchecked leaks can lead to trouble. Inspect and tighten radiator mounts periodically. Test and replace thermostats regularly.

**Note:** In order to ensure the integrity of the system, periodically check cooling system pressure. Pressurize the cooling system to 103-138 kPa (15-20 psi) using Radiator and Cooling System Tester, J24460-1. Do not exceed 138 kPa (20 psi). Any measurable drop in pressure may indicate a leak. Whenever the oil pan is removed, check the cooling system pressure as a means of identifying any incipient coolant leaks. Make sure that the cause of the internal leak has been corrected before flushing the contaminated system.

Leaks at the thermostat housing hose connections may be caused by deformation and rough surfaces on the castings of the hose mounting surfaces. It is recommended that "Dow Corning RTV-102 Compound" or any equivalent product be applied on cast surfaces prior to hose installation.

**Caution:** Castings should be clean and free of oil and grease before applying compound. No other sealer should be used with RTV-102 compound.

## 2. HOSES

### 2.1 Inspection

Rotten, swollen, and worn out hoses or loose connections are frequent causes of cooling system problems.

Serious overheating is often caused by an old hose collapsing or from rotten rubber shedding from hoses and clogging the coolant passages.

Connections should be inspected periodically and hose clamps tightened. Replace any hose found to be cracked or swollen.

When installing a new hose, clean pipe connections and apply a thin layer of a non-hardening sealing compound. Replace worn out clamps or clamps that pinch hoses.

### 3. CONSTANT-TORQUE HOSE CLAMPS

#### 3.1 Description

All hose clamps of 1 3/8" I.D. and over, used on the heating and cooling systems, are of the "constant-torque" type. These clamps are worm-driven, made of stainless steel, and provided with a series of Belleville spring washers. They also feature an extended integral liner that covers the band slots to protect soft/silicone hoses from damage, and help maintain consistent sealing pressure.

This type of clamp is designed to automatically adjust its diameter to compensate for the normal expansion/contraction of a hose and metal connection that occurs during vehicle operation and shutdown. The constant-torque clamp virtually eliminates coolant losses due to "cold flow" leakage and greatly minimizes clamp maintenance.

#### 3.2 Installation

Use torque wrench for proper installation. The recommended torque is 90 to 100 lbf•in. (10 to 11 N•m). The Belleville spring washer stacks should be nearly collapsed flat and the screw tip should extend 1/4" (6 mm) beyond the housing (see fig. 3).

**Caution:** *The hose clamps will break if overtorqued. Do not overtighten, especially during cold weather when hose has contracted.*

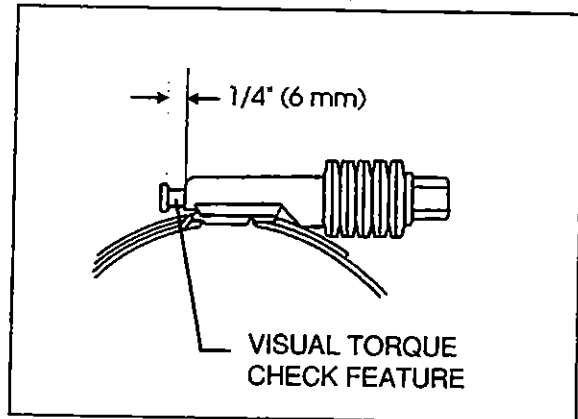

Figure 3: Constant-torque Clamp

MA3E0502

#### 3.3 Maintenance

The constant-torque clamps contain a "visual torque check" feature. When the tip of the screw is extending 1/4" (6 mm) out of the housing, the clamp is properly installed and maintains a leak-proof connection (Fig. 3). Since the constant-torque clamp automatically adjusts to keep a consistent sealing pressure, there is no need to retorque hose clamps on a regular basis. During vehicle operation and shutdown, the screw tip will adjust according to the temperature and pressure changes. Proper torque installation should be checked at room temperature.

### 4. COOLANT

#### 4.1 Thawing cooling System

If the cooling system becomes frozen solid, place the coach in a warm area until the ice is completely thawed. Under no circumstances should the engine be operated when the cooling system is frozen, since it will result in engine overheating due to insufficient coolant.

#### 4.2 Coolant Level Verification

Coolant level is correct when the cold coolant is visible through the surge tank sight glass. If coolant level is low, fill cooling system (Fig. 4).

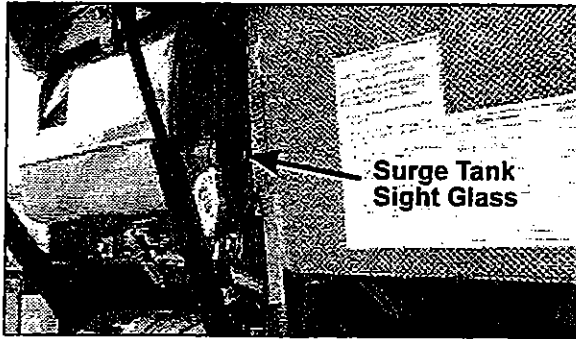

Figure 4: Coolant Level Verification

OEH3B724

### 4.3 Cooling Level Sensor

The "loss of coolant warning device", consists of a level probe mounted on the surge tank and a sensor module mounted on the vehicle. The module sends a signal to the ECM to indicate coolant level. If the coolant level drops below the probe the Check Engine light flashed and diagnostic code is registered (see Section 1, Engine).

**Caution:** Do not run engine with the Check Engine light flashing.

The level probe is mounted on the R.H. side of the surge tank while the electronic module is mounted inside the rear electric junction box.

### 4.4 Coolant Requirements

The coolant provides a medium for heat transfer and controls the internal temperature of the engine during operation. In an engine having proper coolant flow, some of the combustion heat is conveyed through the cylinder walls and the cylinder head into the coolant. Without adequate coolant, normal heat transfer cannot take place within the engine and engine temperature rapidly rises. Therefore, coolant must be carefully selected and properly maintained.

Coolant solutions must be carefully selected and properly maintained in order to meet the following basic requirements:

1. Provide adequate heat transfer.
2. Provide protection from cavitation damage.
3. Provide a corrosion/erosion-resistant environment within the cooling system.
4. Prevent formation of scale or sludge deposits in the cooling system.
5. Be compatible with the cooling system hose and seal materials.
6. Provide adequate freeze protection during cold weather operation.

The first five requirements are satisfied by combining suitable water with reliable inhibitors. When freeze protection is required, a solution of suitable water and antifreeze containing adequate inhibitors will provide a satisfactory coolant. Ethylene glycol-based antifreeze is recommended for use in Series 60 engines. The cooling system capacity is 24 US gal (91 liters).

**Note:** In general, antifreeze does not contain adequate inhibitors. For this reason, supplemental coolant additives are required.

For a complete overview of engine coolants used with Detroit Diesel Engines, refer to Section 13.3 Coolant specification in the Detroit Diesel Engine manual.

### 4.5 General Cooling System Recommendations

Always maintain cooling system at the proper coolant level. Check coolant level daily.

The cooling system must be pressurized to prevent localized boiling of coolant. The system must be kept clean and leak-free. The filler cap and pressure cap must be checked periodically for proper operation.

## 4.6 Coolant Recommendations

1. Always use recommended antifreeze, inhibitor and water at proper concentration levels. A 50% coolant/water solution is normally used as factory fill. Concentrations over 70% is not recommended because of poor heat transfer capability, adverse freeze protection and silicate dropout. Concentrations below 30% offers little freeze, boilover or corrosion protection.
2. Use only ethylene glycol antifreeze meeting the GM 6038-M or ASTM D 4985 formulation, or an equivalent antifreeze with a 0.15% maximum silicate content meeting GM 1899-M performance specifications.
3. Use an antifreeze solution year-round for freeze and boil-over protection. Seasonal changing of coolant from an antifreeze solution to an inhibitor/water solution is recommended.
4. Pre-mix coolant makeup solutions at proper concentrations before adding to the cooling system.
5. Maintain the prescribed inhibitor strength levels as required.

### Vehicles Without Coolant Filter

Refer to Nalcool 3000 with Stabil-Aid bulletin annexed to the end of this section for preventive maintenance (at each oil change) and initial treatment instructions (each time the cooling system is drained, flushed and cleaned).

### Vehicles With Coolant Filter

Change the coolant maintenance filter at each oil change (see specifications at the end of this section). Use a coolant precharge filter each time the cooling system is drained, flushed and cleaned.

**Note:** *The coolant filter contain inhibitors.*

6. Do not mix different base inhibitor packages.
7. Use only non-chromate inhibitors.

**Caution: DO NOT USE THE FOLLOWING:**

- Soluble oil
  - Chromate inhibitor
  - Methoxy propanol-base antifreeze
  - Methyl alcohol-base antifreeze
  - Sealer additives or antifreezes containing sealer additives
8. Distilled water is recommended.
  9. Always maintain proper coolant level.

**Note:** *Always test the solution before adding water or antifreeze.*

10. If not at the proper protection level, mix coolant/water solution to the proper concentration before adding to the cooling system.

**Warning:** *Never remove fill cap while coolant is hot. When coolant is at ambient temperature, release pressure from system by turning the pressure cap counterclockwise 1/4 turn; then remove filler cap slowly. A sudden release of pressure from a heated cooling system can result in severe burns from the expulsion of hot coolant.*

## 4.7 Draining Cooling System

The cooling system may be completely or partially drained by using the following procedures.

The engine and related components may be drained as follows:

## Section 05 : COOLING SYSTEM

1. Stop engine and allow engine fin to cool. Close both heater line shutoff valves. One located in the engine compartment under the radiator fan gearbox (Fig. 5). The other heater line shutoff valve is located in the L.H. rear electric compartment (near the preheater, see Fig. 6). Refer to Section 22, Preheating System, to gain access to the preheater and the heater line shutoff valve .

**Warning:** Before proceeding with the following steps, make sure that coolant has cooled down. The sudden release of pressure from a heated cooling system can result in loss of coolant and severe burns (scalding) from the hot liquid.

2. Remove the pressure cap. Removal of the pressure cap permits air to enter the cooling passages and the coolant to drain completely from system.
3. Open the drain cock located at the right rear corner of the engine (Fig. 7).
4. Open the water pump housing inlet line drain cock (Fig. 8).
5. Open the drain cock at the bottom of the thermostat housing to drain the coolant trapped above the thermostats (Fig. 8).
6. Open the water pump drain cock (Fig. 10, if applicable).
7. Open the radiator drain cock (Fig. 5).
8. Open engine drain cock (Fig. 11).

**Note:** if freezing weather is anticipated and the engine is not protected by antifreeze, drain the cooling system completely when the engine is not use. Leave the drain plugs out until the cooling system is refilled. Trapped water in the cylinder block, radiator or other engine parts may freeze and expand resulting in damage to the engine.

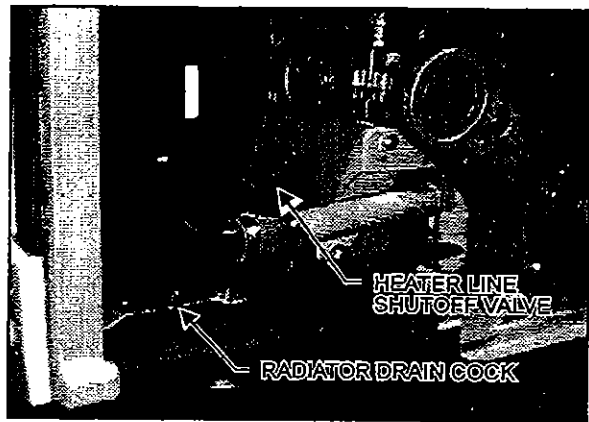

Figure 5: Engine Compartment

05025

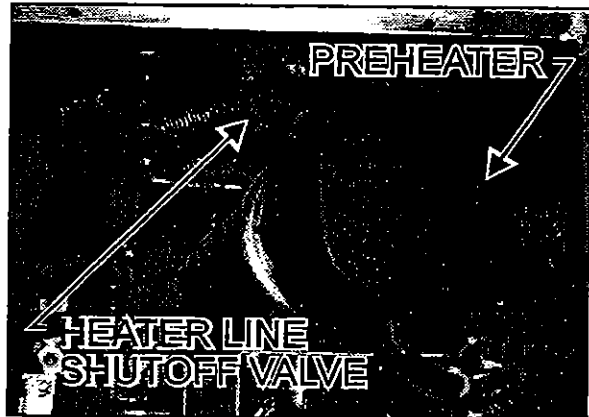

Figure 6: Rear Electric Compartment

05026

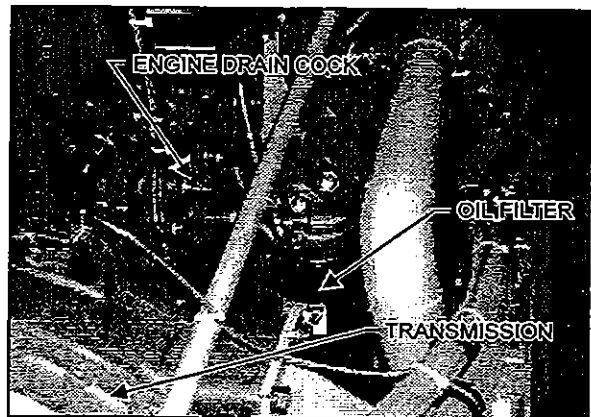

Figure 7: Right Rear Corner of Engine

05027

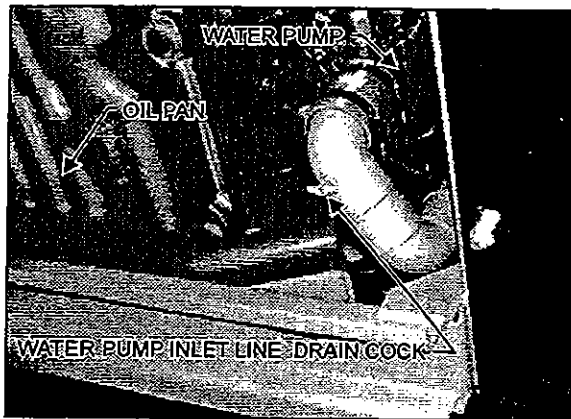

Figure 8: View From Under the Vehicle 05028

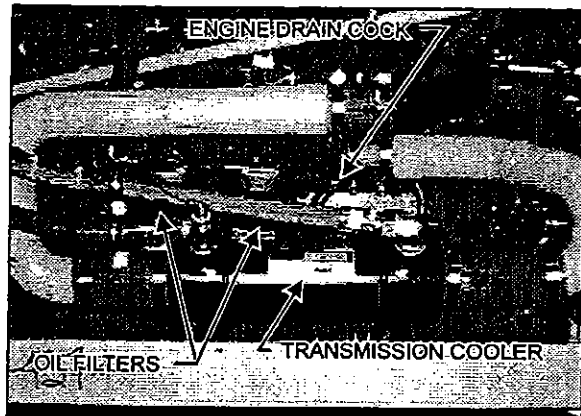

Figure 11: Engine Drain Cock 05031

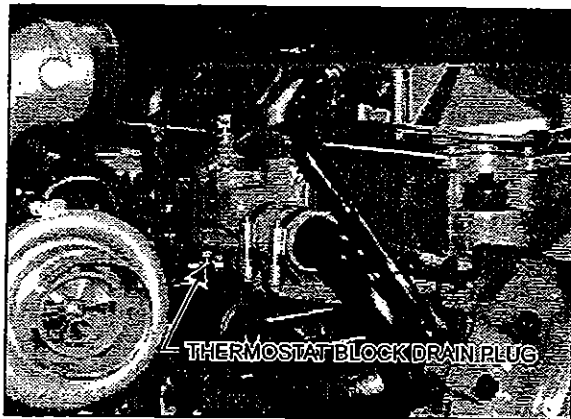

Figure 9: Thermostat Block Drain Plug 05029

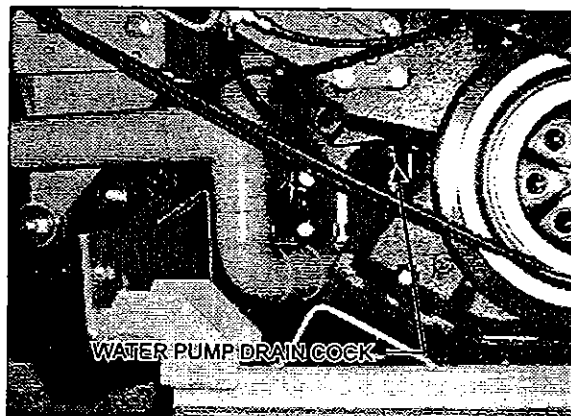

Figure 10: Water Pump Drain Cock 05030

To drain the entire system, repeat the previous steps while maintaining the shutoff valves in their open position. Follow the procedure under the heading Draining Heating System in Section 22, to simultaneously drain the heating units.

## 4.8 Refilling Cooling system

If only the engine and related components have been drained, place the two heater line shutoff valves in their closed position, then proceed as follows:

1. Close all drain cocks. Refer to the draining cooling system procedure for the location of draining points.
2. From the surge tank filler cap inlet, refill cooling system with a recommended ethylene glycol-base antifreeze and water solution with the required concentration. Add required Detroit Diesel selected product cooling system inhibitors.

**Note:** The coolant level should remain within two inches of the surge tank filler neck.

**Note:** Make sure that the vent line from the top of the thermostat housing is properly connected and not obstructed. The vent line (thermostat housing dome to radiator top tank) is required to ensure complete engine fill and proper venting of air in the system.

## Section 05 : COOLING SYSTEM

3. Install the filler and pressure caps. Start the engine and run it at fast idle until normal operating temperature is reached (check for leaks).

**Note:** *If for any reason, the coolant level drops below the surge tank level probe, the Check Engine light will flash.*

4. Stop engine and let cool.

**Caution:** *Never pour cold coolant into a hot engine. The sudden change in temperature may crack the cylinder heads or block.*

5. Open the two heater line shutoff valves. Check the coolant level in the surge tank. Add coolant as required.

If the entire system has been drained, repeat the previous steps while keeping the two heater line shutoff valves in the "Open" position. With engine running, activate the driver's and central heating systems to permit coolant circulation. Bleed the heater cores as explained in Section 22, under heading Bleeding Heating System.

### 4.9 Flushing

If the cooling system is contaminated, flush the cooling system as follows:

1. Drain the coolant from the engine.
2. Refill with soft clean water.

**Note:** *If the engine is hot, fill slowly to prevent rapid cooling and distortion of the engine castings.*

3. Start the engine and operate it for 15 minutes after the thermostats have opened to thoroughly circulate the water.
4. Drain the unit completely.
5. Refill with clean water and operate for 15 minutes after the thermostats have opened.

6. Drain the unit completely.
7. Fill with 50/50 antifreeze and water solution. Add required inhibitors. Change the coolant filter (if applicable) for a precharge filter. In this case, do not mix inhibitors with antifreeze/water solution.

### 4.10 Cooling System Cleaners

If the engine overheats, and the fan belt tension, water level, and thermostat operation have been found to be satisfactory, it may be necessary to clean and flush the entire cooling system.

Remove scale formation by using a reputable and safe descaling solvent. Immediately after using the descaling solvent, neutralize the system with the neutralizer. It is important that the directions printed on the container of the descaler be thoroughly read and followed.

After the solvent and neutralizer have been used, completely drain the engine and radiator and reverse flush before filling the system.

### 4.11 Reverse Flushing

After the engine and radiator have been thoroughly cleaned, reverse flush the system. The water pump should be removed and the radiator and engine reverse flushed separately to prevent dirt and scale deposits clogging the radiator tubes or being forced through the pump. Reverse flushing is accomplished by hot water, under pressure, being forced through the cooling system in a direction opposite to the normal flow of coolant, loosening and forcing deposits out.

#### Radiator Reverse Flushing

The radiator is reverse flushed as follows:

1. Remove the radiator inlet and outlet hoses. Replace the radiator cap.
2. Attach a hose to the top of the radiator to lead water away from the engine.



3. Attach a hose at the bottom of the radiator. Insert a flushing gun in the hose.
4. Connect the water hose of the gun to the water outlet and the air hose to the compressed air outlet.
5. Turn on the water. When the radiator is full, turn on the air in short blasts, allowing the radiator to fill between blasts.
6. Continue flushing until only clean water is expelled from the radiator.

#### Cylinder Head and Cylinder Reverse Flushing

The cylinder block and cylinder head water passages are reverse flushed as follows:

1. Remove the thermostats and the water pump.
2. Attach a hose to the water inlet of oil cooler housing to drain water away from engine.
3. Attach a hose to the water outlet at the top of the cylinder head (thermostat housing). Insert the flushing gun in the hose.

**Caution:** Apply air gradually. Do not exert more than 138 kPa (20 psi) air pressure. Too great a pressure may rupture a radiator tube.

4. Turn on the water. When the jackets are filled, turn on the air in short blasts, allowing the engine to fill with water between air blasts.
5. Continue flushing until the water from the engine runs clean.

If scale deposits in the radiator cannot be removed by chemical cleaners reverse flushing as outlined above, it may be necessary to remove the upper tank and clean out the individual radiator tubes with flat steel rods. Circulate the water through the radiator core from the bottom to the top during this operation.

## 5. Coolant Filter (Spin-on Type) (if applicable)

### 5.1 Description

The engine cooling system filter is used to eliminate the adding of inhibitors in the antifreeze/water solution; and filter impurities such as scale or sand from the coolant. The filter is available as optional equipment. It is mounted to the engine cradle (close to the engine water pump, Fig. 12).

The precharge element filter lasts for 12,500 miles (20 000km) or a year, whichever comes first. Replace the precharge element filter with a maintenance element filter, which lasts for 200,000 miles (320 000 km) or every two years, whichever comes first. Every time the cooling system is flushed, drained and cleaned, you must first install a precharge element filter for its required lifespan; then install a maintenance element filter. Both filters must be changed at specified intervals.

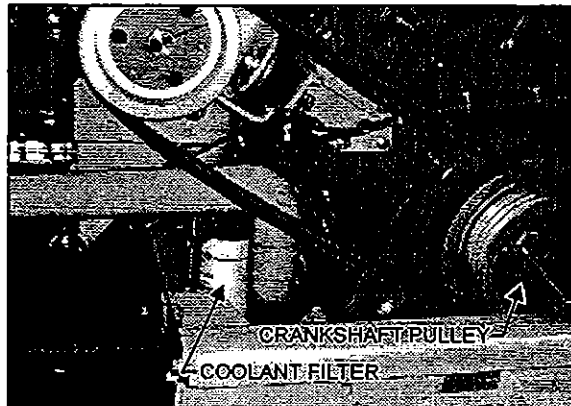

Figure 12: Coolant Filter Location

05032

**Note:** If a coolant system filter and conditioner is to be installed on an engine which has been in service, drain and flush the cooling system prior to installation of the filter.

#### To replace a filter:

1. Close the two shutoff cocks at the filter mounting heads. Unscrew the old filters from under the vehicle.
2. Remove and discard the filter.
3. Clean the filter adapter with a clean, lint-free cloth.

## Section 05 : COOLING SYSTEM

4. Coat surface of gasket with oil. Tighten 2/3 to 1 turn after gasket contacts base.
5. Open the two shutoff cocks at filter.
6. Start engine and check for leaks.

**Caution:** Do not exceed recommended service intervals.

## 6. RADIATOR

The radiator is mounted at the L.H. side of engine compartment. The radiator is designed to reduce the temperature of the coolant under all operating conditions. It is essential that the radiator core be kept free from corrosion and scale at all times.

### 6.1 Maintenance

Inspect the exterior of the radiator core every 25,000 miles (40 000 km) or once a year, whichever comes first. Clean radiator with a quality grease solvent, such as a mineral spirits and dry with compressed air. Do not use fuel oil, kerosene or gasoline. It may be necessary to clean the radiator more frequently if the engine is being operated in extremely dusty or dirty areas.

## 7. RADIATOR VARIABLE SPEED FAN

### 7.1 Description

The radiator speed fan is thermostatic. The two speeds are controlled by the engine temperature (coolant temperature and air inlet temperature). The fan drive clutch is electromagnetic. An electric current regulates speeds by activating one magnetic coil for the first speed and two magnetic coils for the second speed.

The settings are:

For Series 60 engine  
Motor serial number less or equal to (<=)  
06R0194000.

- 204°F (96°C) First speed
- 208°F (98°C) Second speed

For Series 50 and Series 60 engine motor serial number from 06R0194000 inclusively and more (<=).

- 196°F (91°C) First speed
- 203°F (95°C) Second speed

**Caution:** Mechanical locking device. In case of an electrical power failure: unscrew the bolt from the end of the shaft and screw it into the locking plate. This procedure will prevent engine overheating (Fig. 13).

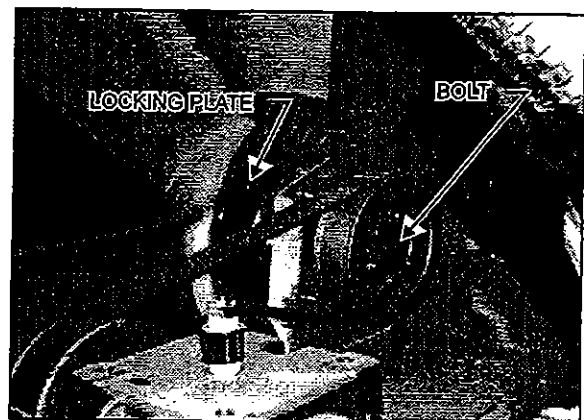

Figure 13: Mechanical Locking Device

05033

### 7.2 Maintenance

1. Clean the fan and related parts with clean fuel oil. Dry with compressed air. Do not clean with steam or high pressure jet.
2. Check the fan blades for cracks or other damage. Replace the fan if the blades are cracked or deformed.
3. Remove any rust or rough spots in the grooves of the fan pulley. If the grooves are damaged or severely worn, replace the pulleys.
4. Do not add any fluids or lubricants to the fan drive.
5. Do not restrict fan rotation during engine operation for any reason.

6. Do not operate fan drive with a damaged fan assembly. Replace a damaged fan as soon as a fault is found.
7. Immediately investigate and correct any operator complaint involving drive or cooling system performance.
8. When questions arise, obtain answers before proceeding. Assistance is available through the authorized Field Sales distributor serving your area.

### 7.3 Inspection

Inspect as follows:

**Warning:** Set the starter selector switch in the engine compartment to the "Off" position to prevent accidental starting of the engine.

- Check security of fasteners holding fan blade assembly to fan drive.
- Check coupling installation to gearbox.
- Visually inspect fan drive, fan blade assembly, shroud, radiator, and surrounding area for evidence of contact between rotating and non-rotating parts.
- Check fan transfer belt for fraying, cracking, and proper tension.
- Turn fan through at least 360° of rotation. It should turn smoothly, and be free of resistance.

### 7.4 Thermostat Operation

The temperature of the engine coolant is controlled by two blocking-type thermostats located in a housing attached to the right side of the cylinder head (Fig. 14).

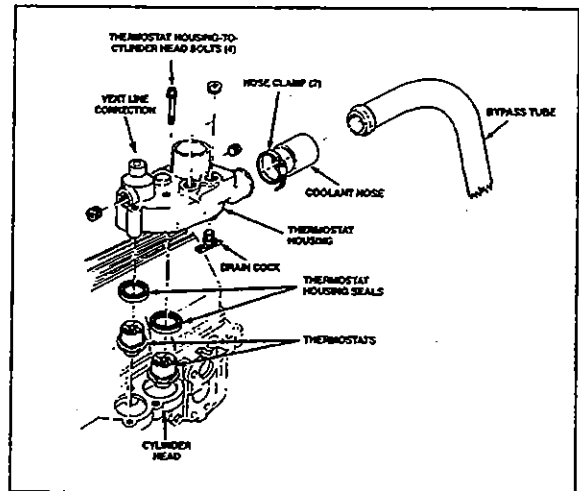

Figure 14: Thermostat and Related Parts 05034

At coolant temperature below approximately 190°F (88°C), the thermostat valves remain closed and block the flow of coolant from the engine to the radiator. During this period, all of the coolant in the system is recirculated through the engine and directed back to suction side of the water pump via a bypass tube. As the coolant temperature rises above 190°F (88°C) the thermostat valves start to open, restricting the bypass system, and allowing a portion of the coolant to circulate through the radiator. When the coolant temperature reaches approximately 205-207°F (96-97°C) thermostat valves are fully open, the bypass system is blocked off, and the coolant is directed through the radiator.

## 8. FAN GEARBOX

### 8.1 Description

The radiator fan is belt driven from the engine crankshaft pulley through a gearbox standard assembly which is provided with two output output shafts.

### 8.2 Maintenance

Break-in the gearbox oil at 3 000 miles (4 800 km) and subsequently every 50,000 miles (80 000 km) or once a year, whichever comes first.

### 8.3 Oil Change

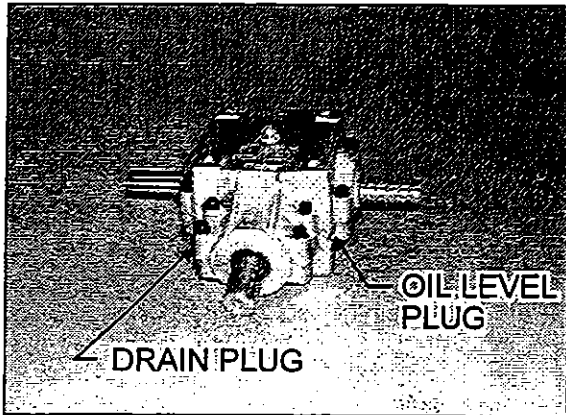

Figure 15: Fan Gearbox

05008

1. Stop engine and make sure that all engine safety precautions have been observed.
2. Unscrew the air vent tube to permit the air to enter (Fig. 15).
3. Remove the drain plug located at the gearbox base.
4. Drain the gearbox.
5. Replace the drain plug.
6. Remove the level plug located on the middle side of the gearbox, near the air bellow tensioner.
7. Fill the gearbox with synthetic oil (Esso imperial mobil SHC 634 [68-2268]) until the oil runs out of the plug.
8. Install plugs on the side of the gearbox and the air vent tube.

### 9. RADIATOR FAN BELT REPLACEMENT AND AIR BELLOWS BELT TENSIONER

1. Locate the belt tensioner control valve (Fig. 16). To release belt tension, turn handle counterclockwise in order to reverse pressure in belt tensioner air bellows.
2. Remove old belts (3 V belts and 1 Poly) from fan assembly. Install new belt.
3. Turn the two-way control valve clockwise, to its initial position, to apply tension on the new belt.
4. For proper operation of the belt, adjust the air bellow tensioner pressure regulating valve to 50 psi (345 kPa) for vehicles with series 60 engine and to 70 psi (483 kPa) for vehicles with series 50.



Figure 16

05035

### 10. FAN DRIVE ALIGNMENT

1. Install both attachment assembly plates (48, Fig. 17) through lower plating. Secure with four spring nuts (70, Fig. 17). Install one spacer (49, Fig. 17) on spring nuts at both anchoring locations.

- Center seat assembly in the fan shroud using the horizontal displacement of the fan drive installation. Center with the slots in the floor at anchoring angle support (on some vehicles only). The vertical displacement of the fan clutch is made possible by slots at the base of the fan clutch (on some vehicles only) or by shimming with additional spacers at anchoring locations. Temporarily secure assembly with two temp. nuts (74, Fig. 17), 7/16-20, part number 50-0709 at both anchoring locations.

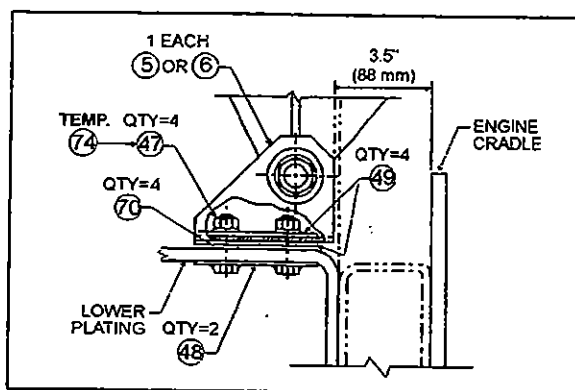

Figure 17: Angle Support

05014

**Caution:** Tilt fan and check for clearance.

- Using a straight edge, align the 3"V" pulley on gearbox central shaft pulley with engine pulley, while taking pulleys outer edge thickness under consideration. That is, the 3 "V" pulley's outer edge is thicker than the engine pulley's outer edge (Fig. 18).

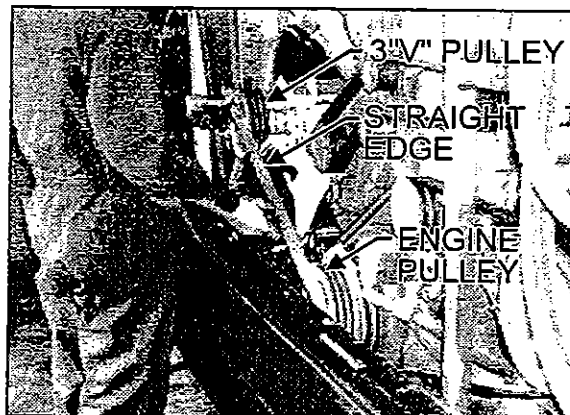

Figure 18: Pulley Alignment

05015

- Using a universal protractor, check 3 "V" pulley's vertical angle with that of engine pulley's. If angles do not correspond, raise seat assembly by shimming with additional spacers (49, Fig. 17).

**Note:** Use a straight edge to measure engine pulley's vertical angle. (Fig. 19)

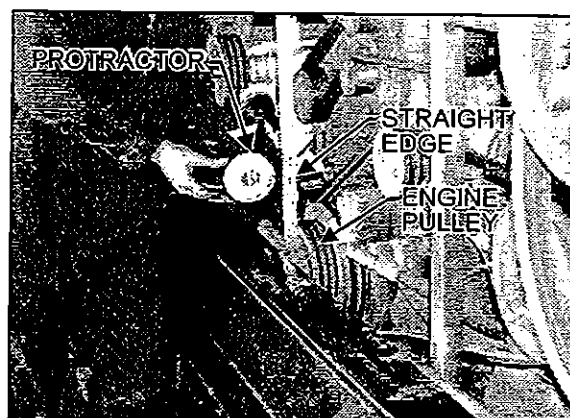

Figure 19: Measuring Engine Pulley Vertical Angle

05016

- Recheck alignment (steps 3, 4 and 5). Replace temporary anchoring nuts (74, Fig. 17) with four nuts (47, Fig. 17), part number 50-0714. Tighten with wrench.
- Align Multi"V" Pulley with Fan Pulley. Adjust the depth of the pulley on the gearbox shaft.

Section 05 : COOLING SYSTEM

**Caution:** In order for tensioning system to work properly, the distance between the inside faces of "tensioning arm to engine" bellow brackets should be between 2 3/8" (60 mm) and 2 1/2" (64 mm); if not, release tension on system and readjust distance using bolts securing upper tensioning bracket (Fig. 20).

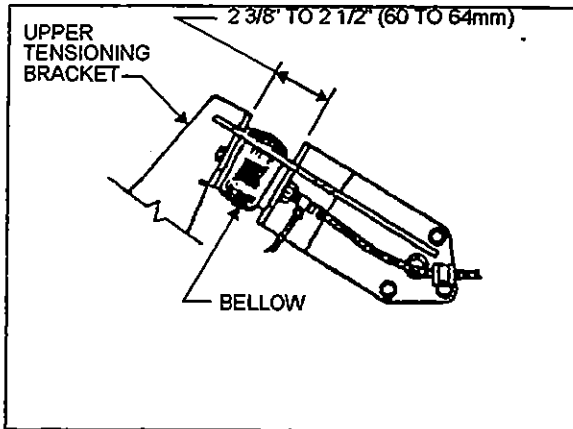

Figure 20: Upper Tensioning Bracket 12017

7. Reset belt tensioning pressure control valve to 50 psi (345 kPa) for vehicles with series 60 engine and to 70 psi (483 kPa) for vehicles with series 50 in accordance with Section 12, Brake (Fig. 21).

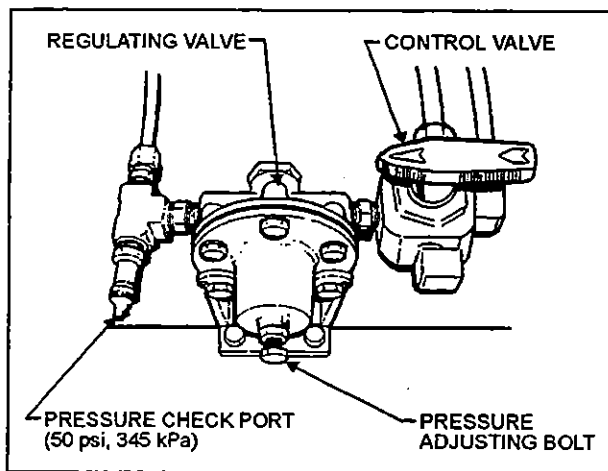

Figure 21: Belt Tensioning Pressure Control Valve 12018

## 11. SPECIFICATIONS

### Cooling System Capacity (Approx.)

Includes heating system.....24 US gal (91 liters)

### Thermostat

Number used ..... 2  
 Start to open ..... (186-193 °F) 86-89 °C  
 Fully open ..... 207 °F (97 °C)

### Radiator

Make ..... Long  
 Location ..... Rear L.H. side  
H3-41" & H3-45" Coaches  
 Supplier number ..... 7601-8317-1  
 Prevest number ..... 55-0687  
H3-45 VIP  
 Supplier number ..... 7601-8336  
 Prevest number ..... 55-0689

### Surge Tank Filler Cap

Make ..... Stant  
 Model ..... R3  
 Prevest number ..... 53-0191

### Pressure Cap

Make ..... Stant  
 Pressure setting ..... 14 psi (96.53 kPa)  
 Supplier number ..... R12  
 Prevest number ..... 55-0606

### Fan Clutch

Make ..... Linnig  
 Type ..... 3 speeds  
 Supplier number ..... LA1.2.024Y  
 Prevest number ..... 55-0634

**Note:** The fan clutch is controlled by DDEC (not by thermostitch).

### Fan Gearbox

Make ..... Superior Gearbox  
 Ratio ..... 1:1  
 Supplier number ..... 411ACF-097-6  
 Prevest number ..... 55-0688

**Section 05 : COOLING SYSTEM**

---

**Fan Belt (gearbox-fan)**

Make ..... Dayco  
Type ..... Poly  
Qty ..... 1  
All H3'S  
Supplier number ..... 5100495  
Prevost number ..... 50-6663

**Fan Belt (gearbox-motor)**

Make ..... Dayco  
Type ..... V belt  
Qty ..... 3

H3-45 Coaches & VIP

Supplier number ..... AX73  
Prevost number ..... 50-6691

H3-41 Coaches

Supplier number ..... AX74  
Prevost number ..... 50-6690

**Corrosion Inhibitor and Coolant Stabilizer**

Supplier number.....Detroit D. .... 23507857  
Supplier number.....Nalco..... DD3000-15

**Coolant Filter**

Number used ..... 1  
Make ..... Nalco  
Type ..... Spin-on

MAINTENANCE ELEMENT FILTER

Supplier number. ....Detroit Diesel ..... 23507545  
Supplier number.....Nalco..... DDF3000  
Prevost number ..... 55-0630

PRECHARGE ELEMENT FILTER

Supplier number. ....Detroit Diesel ..... 23507189  
Supplier number.....Nalco..... DDF60  
Prevost number ..... 55-0629

**Temperature Gage (in engine compartment)**

Make ..... VDO Yazaki  
Operating range..... 100-265 °F (40-130 °C)  
Supplier number ..... 1 131 015 015B  
Prevost number ..... 56-2331

**Temperature Gage (on instrument panel)**

Make ..... Datcon  
Type ..... Electrical  
Operating range..... 100-280 °F (38-138 °C)  
Supplier number ..... 07718-40  
Prevost number ..... 56-2214





**Dosage - Cont'd**

hours unless there is an unusual water loss. For systems larger than 76 L capacity, add 0.473 L for every 76 L at each service interval. When NALCOOL 3000 with

STABIL-AID is used at each maintenance interval, both corrosion protection and coolant stability are maintained in your engine system.

**Handling**

Handle like any alkali. Avoid contact with eyes. Avoid prolonged or repeated contact with skin. Do not take internally. May cause eye or skin irritation. May be harmful or fatal

if swallowed. Product may be stored up to one year. NALCOOL 3000 with STABIL-AID becomes "mushy" at -9°C (15°F), but is satisfactory for use after complete thawing.

**Shipping**

NALCOOL 3000 with STABIL-AID is supplied in cases containing twelve 0.473-L (16 fluid

oz.) bottles, in 23-L pails, 115-L and 210-L non returnable drums.

**Instructions for Use**

Protect your cooling system against deposit formation caused by unstable engine coolant. In addition, protect your cooling system against corrosion, cavitation-erosion, mineral scale deposits and electrolysis. Use NALCOOL 3000 with STABIL-AID for total cooling system protection.

1. **Before Treatment** — The ingredient STABIL-AID will not dissolve gel once it has formed. For proper use, drain coolant and clean with NALCO NALPREP 2001 Cooling System Cleaner (add 1.89 L of NALPREP 2001 for each 30 L of cooling system capacity). Run your engine for a minimum of two hours with the NALPREP/water mixture. Allow engine to cool and flush with fresh water. **NOTE:** If gel has already dried or your radiator is completely blocked, we recommend ultrasonic cleaning.
2. **Initial NALCOOL 3000 with STABIL-AID Treatment** — See chart below for the number of litres of NALCOOL 3000 with STABIL-AID required to bring the cooling system up to full protection at initial fill.

**Cooling System Capacity:**

4 - 15 L (1-4 USG)	Add 0.473 L (1 pint)
19 - 30 L (5-8 USG)	0.946 L (2 pints)
34 - 45 L (9-12 USG)	1.419 L (3 pints)
49 - 61 L (13-16 USG)	1.892 L (4 pints)
64 - 76 L (17-20 USG)	2.365 L (5 pints)
79 - 91 L (21-24 USG)	2.838 L (6 pints)
95 - 106 L (25-28 USG)	3.311 L (7 pints)
Over 106 (over 28 USG)	0.473 L (1 pint) per 15 L

When freeze protection is desired, use only ethylene glycol based antifreeze.

3. **Preventive Maintenance with NALCOOL 3000 with STABIL-AID**
  - A. **Line-Haul (High Mileage) Trucks** — At every routine "B" service (typically 16,000 to 19,000 km).  
System Capacity 76 L or less - Add 0.473 L  
  
System Capacity over 76 L - Add 0.473 L for every 76 L or fraction thereof (e.g. 114 L - add 0.946 L)
  - B. **P&D (Low Mileage) Trucks, Stationary and Marine Units** - At every 250 operating hours.  
System Capacity 76 L or less - Add 0.473 L  
  
System Capacity over 76 L - Add 0.473 for every 76 L or fraction thereof (e.g. 114 L - add 0.946 L)

**Quality**

Nalco Canada certifies that all received batches of NALCOOL 3000 meet or exceed

all in-process and finished product quality standards set for this product.

**Remarks**

For Transportation Emergencies involving Nalco products call: 1-800-483-3216.

For Medical Emergencies involving Nalco products call 416-632-8791 (24-hr. response).



**NALCOOL 3000®  
with STABIL-AID**

**COOLING SYSTEM  
CORROSION INHIBITOR  
AND COOLANT STABILIZER**

**Product Benefits**

- Stabilizes engine coolants helping prevent the formation of abrasive gel-like deposits that can form from overconcentrations of:
  - coolant additives
  - hard water salts
  - corrosion products
  - antifreeze products (particularly high silicate antifreeze formulations)
- Helps condition cooling system water by neutralizing hard water salts, preventing them from forming scale deposits on heat transfer surfaces
- Helps protect all metals in engine cooling systems from corrosive attack. Helps protect against liner pitting and cavitation-erosion
- Lubricates water pump
- Helps keep engines free from heat-absorbing sludge and mineral scale deposits — prevents overheating
- Helps extend antifreeze life
- Comes in liquid form for simple application — add directly to the engine radiator or cooling system
- Does not affect gaskets and hoses

**Principal Uses**

NALCOOL 3000 with STABIL-AID is a new advanced cooling system treatment formulation that helps prevent gel-like deposits from forming in cooling system passages. Hard water salts can combine with coolant additives, corrosion products and antifreeze to form gel-like deposits that can plug cooling system passages solid. Further, this abrasive gel can cause excessive wear damage to water pump seals and other cooling system components. NALCOOL 3000 with STABIL-AID helps block the chemical formation of this cooling system gel. It allows the safe use of current

antifreeze formulations and coolant additive products in hard water without the occurrence of gelation problems. In addition, this new formulation helps prevent hard water salts from forming scale deposits on heat transfer surfaces. NALCOOL 3000 with STABIL-AID also helps provide superior film-forming corrosion protection for all metals found in engine cooling systems. It helps keep engine cooling systems clean and free from corrosive attack and the harmful effects of mineral scale deposits. This allows for maintained design heat transfer efficiencies and long engine life.

**General Description**

NALCOOL 3000 with STABIL-AID has the following typical characteristics:

Colour	red
Odour	none

Relative density at (15°C)	1.14
pH (± 0.1)	11.8
Solubility in water	soluble in all proportions

**Dosage**

**Initial Treatment - New Engines:** To assure a clean system, free from both corrosion and scale deposits, add 0.473 L of NALCOOL 3000 with STABIL-AID to the radiator for every 15 L of engine cooling system capacity.

**Note: Engines Already in Service:** It is recommended that engines be cleaned with NALPREP 2001 Engine Cooling System

Cleaner to remove existing gel deposits before starting a NALCOOL 3000 with STABIL-AID program.

**Maintenance Dosage: All Engines:** A make-up dosage of 0.473 L of NALCOOL 3000 with STABIL-AID should be added at every routine "B" service interval (oil change), typically every 16,000 to 19,000 km or 250

Continued on reverse.

**NALCO CANADA INC.**

1055 TRUMAN STREET □ P.O. BOX 5002 BURLINGTON, ONTARIO L7R 3Y9







# SECTION 6: ELECTRICAL SYSTEM

---

## CONTENTS

1.	GENERAL DESCRIPTION .....	5
2.	WIRING AND MISCELLANEOUS ELECTRICAL .....	5
2.1	Wiring Diagrams .....	5
2.1.1	Wiring Diagram Symbols .....	5
2.1.2	Using Wiring Diagrams .....	5
2.1.3	Testing Circuits .....	5
2.2	Wires and Connectors.....	6
2.2.1	Wire Sizes and Colors .....	6
2.2.2	Spare Wires .....	6
2.2.3	Cleaning Connectors with a HFC 134A Based Solvent.....	6
2.3	Circuit Breakers.....	6
2.4	Relays.....	7
3.	ELECTRICAL COMPARTMENTS AND JUNCTION BOXES.....	8
3.1	Maintenance.....	8
3.2	Main Electrical Compartment.....	9
3.3	Rear Electrical Compartment and Junction Box.....	9
3.4	Front Electrical Compartment and Junction Box.....	10
3.5	Alarm Junction Box .....	10
3.6	Engine Starting Control Box.....	11
3.7	A/C and Heating Junction Box.....	11
4.	BATTERIES .....	12
4.1	General Description.....	12
4.2	Main Battery Relays .....	12
4.3	Battery Removal and Installation .....	12
4.4	Battery Rating.....	13
4.5	Battery Testing .....	13
4.5.1	Visual Inspection.....	14
4.5.2	Removing Surface Charge .....	14
4.5.3	Load Test .....	14
4.5.4	Testing Battery Cables .....	15
4.6	Battery Charging .....	15
4.6.1	Charging Procedure.....	15
4.6.2	Battery Charging Guide .....	16
4.6.3	Emergency Jump Starting With Auxiliary (Booster) Battery .....	17
4.7	Cleaning and Inspection.....	17
4.8	Common Causes of Battery Failure.....	18
4.9	Troubleshooting.....	18

**Section 6: ELECTRICAL SYSTEM**

---

5. ELECTRICAL SYSTEM MONITOR.....	18
5.1 Warning Lamp Definitions.....	18
5.1.1 Battery Hi/Lo.....	18
5.1.2 Battery Balance.....	19
5.1.3 "Battery" Warning Light.....	19
6. ALTERNATOR.....	19
6.1 Diagnosis of Charging System Problems.....	20
6.1.1 Alternator or Voltage Regulator.....	21
6.2 Alternator Diagnosis.....	21
6.2.1 Diode Check.....	21
6.2.2 Field Winding.....	23
6.2.3 Stator Winding.....	23
6.3 Diode Replacement.....	24
6.3.1 Diode Replacement (in Support).....	24
6.3.2 Diode Replacement (in Frame).....	24
6.4 Field Replacement.....	24
6.4.1 Removal.....	24
6.4.2 Installation.....	24
6.5 Stator Replacement.....	25
6.5.1 Removal.....	25
6.5.2 Soldering Stator Terminal Leads.....	25
6.5.3 Installation.....	25
6.6 Diode End Cover Installation.....	25
6.7 Alternator Replacement.....	26
6.7.1 Removal.....	26
6.7.2 Disassembly of Alternator.....	26
6.7.3 Alternator Cleaning and Inspection.....	27
6.7.4 Bearing or Rotor Replacement.....	27
6.7.5 Reassembly.....	28
6.7.6 Output Check.....	28
6.8 Alternator Drive Belt.....	28
6.8.1 Removal and Installation.....	28
6.8.2 Adjustment.....	28
7. VOLTAGE REGULATOR.....	29
7.1 Description.....	29
7.2 Troubleshooting Procedures.....	29
7.3 Checking Regulator Voltage Setting.....	30
7.3.1 Undercharged Battery.....	30
7.3.2 Overcharged Battery.....	31
7.4 Regulator Checks.....	31
7.5 Adjusting Voltage.....	32
8. BATTERY EQUALIZER.....	32
8.1 Description.....	32
8.2 Operation.....	32
8.2.1 Situation 1.....	32
8.2.2 Situation 2.....	32

8.2.3 Situation 3 .....	32
8.2.4 Situation 4 .....	32
8.3 Advantages .....	33
9. STARTING MOTOR.....	33
9.1 Description.....	33
9.2 Maintenance.....	33
9.3 Troubleshooting.....	34
9.3.1 No-Load Test .....	34
9.3.2 Lock-Torque Test.....	35
9.4 Disassembly and Reassembly.....	35
9.4.1 Disassembly.....	35
9.4.2 Cleaning .....	35
9.4.3 Armature Servicing .....	35
9.4.4 Field Coil Checks.....	36
9.4.5 Field Coil Removal.....	36
9.4.6 Reassembly .....	36
9.5 Pinion Clearance.....	36
9.6 Starter Solenoid.....	37
9.6.1 Description .....	37
9.6.2 Disassembly.....	37
9.6.3 Solenoid Maintenance .....	37
9.6.4 Solenoid Tests .....	37
9.6.5 Recommendations.....	37
10. ENGINE BLOCK HEATER .....	38
10.1 Maintenance .....	38
11. EXTERIOR LIGHTING EQUIPMENT .....	38
11.1 Headlights.....	38
11.1.1 Headlights Dimmer Switch .....	38
11.1.2 Maintenance .....	38
11.1.3 Headlight Adjustment.....	38
11.2 Sealed-Beam Unit Replacement .....	40
11.2.1 Removal.....	40
11.2.2 Replacement.....	41
11.3 Front Turn Signal.....	41
11.3.1 Bulb Removal and Replacement.....	41
11.4 Stop, Tail, Directional, Back-up, and Hazard Warning Lights .....	41
11.4.1 Bulb Removal and Replacement.....	41
11.5 License Plate Light.....	41
11.6 Clearance, Identification and Marker Lights .....	41
11.6.1 Marker Light Bulb Removal and Replacement .....	42
11.6.2 Clearance and Identification Light Bulb Removal and Replacement .....	42
11.7 Docking and Cornering Lights.....	42
11.7.1 Bulb Removal and Replacement.....	42
11.8 Fog Lights.....	42
11.8.1 Bulb Removal and Replacement.....	42
12. INTERIOR LIGHTING EQUIPMENT .....	43

**Section 6: ELECTRICAL SYSTEM**

---

12.1	Control Panel Lighting.....	43
12.1.1	Switch Bulb Replacement.....	43
12.1.2	Indicator Light Bulb Replacement .....	43
12.1.3	Gauge Light Bulb Replacement .....	43
12.1.4	Panel Light Bulb Replacement.....	44
12.2	Stepwell Lights .....	44
12.2.1	Bulb Removal and Replacement.....	44
12.3	Dome Lights .....	44
12.3.1	Bulb Removal and Replacement.....	44
12.4	Passenger Section Lighting .....	44
12.4.1	Removal and Replacement of Aisle Fluorescent Light.....	45
12.4.2	Removal and Replacement of Fluorescent Light.....	45
12.4.3	Removal and Replacement of Reading Lamp Bulb.....	45
12.5	Engine Compartment Lighting .....	45
12.5.1	Circular Light .....	45
12.5.2	Sealed Unit Light.....	46
13.	LIGHT BULB DATA.....	46
14.	SPECIFICATIONS .....	47



## 1. GENERAL DESCRIPTION

This vehicle uses a dual voltage system to obtain two different voltages (12 and 24 volts) for various electrical controls and accessories. The main power source incorporates four maintenance-free "Delco" model 1150 batteries connected in parallel-series. All batteries are kept uniformly charged by means of a 100 amp battery equalizer (standard), giving a maximum possible output supply of 100 amps on the 12 volt system. Both the 12 and 24 volt systems are controlled through individual main battery relays. A 24 volt self-rectified alternator is belt driven from the engine, and can be reached by the engine compartment door.

## 2. WIRING AND MISCELLANEOUS ELECTRICAL

### 2.1 Wiring Diagrams

A master wiring diagram of the electric circuits, covering standard and optional accessories and systems, is located in technical publication box. Usually, a separate wiring diagram page is provided for each major function or system. In some cases, more than one circuit may appear on one wiring diagram page; when it occurs, each circuit covered in this page is listed in the wiring diagram index. Moreover, a circuit may appear on several pages; in such cases, the number(s) at the extremity of diagram title will indicate the sheet reference number. Refer to the "Wiring diagram index" to ensure that the correct diagram is being used to trace the circuit in question.

#### 2.1.1 Wiring Diagram Symbols

Various symbols are used on the wiring diagrams to depict different types of electrical components. It is essential to become familiar with these symbols in order to understand the diagrams. The major symbols shown on the diagrams are identified under "Wiring Diagram symbols" (page K of wiring diagrams).

#### 2.1.2 Using Wiring Diagrams

Two methods are used to "work" with electric wiring diagrams.

1. You have identified the defective part (breaker, diode, relay, etc.), and you wish to locate its corresponding circuit.

**Problem:** Circuit breaker #56 is released (open circuit) and you don't know which circuit is affected.

- a) Refer to wiring diagram index, and look for "Circuit breaker code", pages F.
  - b) At item C.B #56, in the first column, you will find the page on which to find the corresponding diagram, in the second column the breaker ampere rating, and in the third column, the Prévost number. The other columns give you the location and the function of the breaker.
  - c) Refer to page 14 keeping in mind the function of the breaker, i.e. emergency exit lights.
  - d) When you have located "emergency exit lights", follow wiring until you come across C.B #56 and its circuit.
2. You have a problem with a specific system and you want to find the corresponding diagram.

**Problem:** The three (3) last speakers on R.H. side of vehicle are inoperative and you must trace the electric circuit.

- a) Refer to wiring diagram index and look for "Sound system".
- b) You will find on page 26 the components as well as the electric wiring, thus providing you with a complete understanding of this circuit.

#### 2.1.3 Testing Circuits

A careful study of the wiring diagrams should be made to determine the source and flow of current through each circuit. When a circuit is thoroughly understood, a point-to-point check can be made with the aid of the applicable wiring diagrams. Any circuit can be tested for continuity or short circuits with a multimeter or a suitable voltmeter.

All electrical connections must always be kept clean and adequately tight. Loose or corroded connections can result in discharged batteries, difficult starting, dim lights and improper functioning of other electric circuits. Inspect all wiring connections at regular intervals. Make sure knurled nuts on all amphenol-type plugs are securely tightened. Knurled nuts on the plastic amphenol-type connectors will click into a detent when properly tightened. Line connectors, which have the side locking tabs, must have the locks latched in place to ensure a proper electrical connection.

## 2.2 Wires and Connectors

### 2.2.1 Wire sizes and colors

Each wire in the electrical system has a specific size as designated on the wiring diagram. When replacing a wire, the correct size must be used. Never replace a wire with one of a smaller size.

The vehicle electrical system is provided with different voltages. The insulation on each wire is distinctly colored in order to determine visually the wiring voltage and to assist in making connections. The wires are color coded as follows:

Red	24 volt system
Yellow	12 volt system
Black	grounded wire
Blue	110 V ac system (live)
White	110 V ac system (neutral)
Green	110 V ac system (ground)
Orange	speakers (+)
Brown	speakers (-)
Grey	spare wire

**Note:** Wires are identified at each 4-6 inch (10-15 cm) intervals by a printed number.

Each wire on a diagram is patterned to assist in tracing and testing circuits. The wire number identifies the voltage rating, the wire identification number, and the basic wire gauge as illustrated in figure 1.

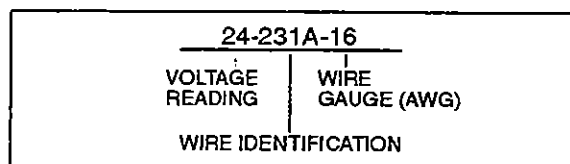

Figure 1

06048

### 2.2.2 Spare Wires

When vehicle leaves factory, and even in the case of a fully equipped vehicle, an important number of unconnected spare wires are routed between the junction boxes. Consequently, for any connection of an additional accessory, refer to page D "Spare wires" in the master wiring diagram to determine the number, the gauge and location of these wires.

**Note:** Spare wires are identified by a wire identification number and by the letters "SP", to designate "spare".

### 2.2.3 Cleaning Connectors with a HFC 134A Based Solvent

When the pins and sockets of connectors become dirty, clean them with a good quality solvent containing HFC 134A refrigerant as its active ingredient. HFC 134A has two qualities that recommend it. First, it does not conduct electricity and therefore, will not cause shorting between connector pins and sockets. Second, it evaporates quickly, eliminating the possibility of condensation within the connectors.

Always shake out or gently blow out any excess HFC 134A before assembling a connector to its mating connector or hardware. HFC 134A trapped in the connector can affect the connector seal.

**Warning:** HFC 134A is toxic. HFC 134A based compounds should always be used in a well-ventilated area, never in a confined space. Use outdoor whenever possible.

## 2.3 Circuit Breakers

All electric circuits are protected by circuit breakers of the "Manual reset" type. The main circuit breakers, as well as those protecting A/C system, are located in the main power compartment, on R.H. side of the vehicle, behind the tag axle.

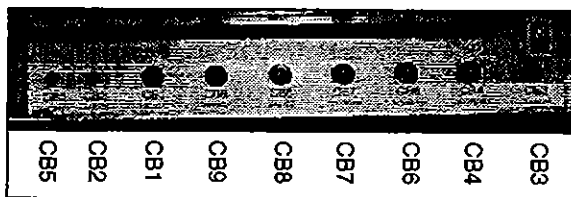

Figure 2

06049

CB1	Ignition	12 volts	40 amps
CB2	Hot Wire	12 volts	30 amps
CB3	Rear Junction Box	12 volts	40 amps
CB4	Front Junction Box	12 volts	40 amps
CB5	Hot Wire	24 volts	30 amps
CB6	Rear Junction Box & Starter Relay	24 volts	90 amps
CB7	Front Junction Box & Inverter Compartment	24 volts	90 amps
CB8	A/C Junction Box & Evaporator Fan	24 volts	150 amps
CB9	A/C Condenser Fan Motor	24 volts	150 amps

The smaller circuit breakers are accessible in front and L.H. rear electrical compartments. This type of circuit breaker deenergizes the circuit without disconnecting any wire. Simply press down the red tab on breaker to open circuit, repair defective circuit, and afterwards depress black button in center of breaker to close circuit.

## 2.4 Relays

Relays are used to automatically energize or deenergize a circuit from a remote location. The relay draws a very low current to energize its coil. Once the coil is energized, it develops a magnetic field which pulls a switch arm closed or open, to either energize or deenergize a given component. As the

control current required for the coil is very low, the relay allows a remote station to control a high energy circuit without running great lengths of costly high capacity cable, and also eliminates the need for high amperage switches and heavy connectors.

Many systems on this vehicle are provided with control relays, which are all located in or on the junction boxes.

**Note:** Each relay is identified with "12 V" or "24 V" printed on its casing in order to identify the coil operating voltage.

**Caution:** The magnetic relays for the starting motor, evaporator and both condenser motors and condenser speed controls should have the 5/16" stud nuts torqued to 50 ± 5 lbf·in (5,5 ± 0,5 N·m).

	Configuration on base	Key printed on casing	Key used on wiring diagram	Example
Cubic relay (Steel or plastic casing) Type: S.P.D.T.		12 V		R #5
<p><b>NOTE:</b> This relay is provided with an internal suppressor diode; never reverse wiring terminals #85 and 86 at base as a direct short circuit will result.</p> <p>The relay coils connected to the alternator "relay terminal" should never be provided with a suppressor diode as the output current at this terminal is not rectified, thus rendering relay inoperative.</p>				
Magnetic relay (Round steel casing) Type: S.P.S.T.		None		R #4
Magnetic relay (Round steel casing) Type: D.P.D.T.		None		R #40
<p><b>LEGEND</b></p> <p>Bat. Battery                      N.O. Normally Open                      N.C. Normally Closed                      S.P.D.T. Single Pole Double Throw                      S.P.S.T. Single Pole Single Throw                      D.P.D.T. Double Pole Double Throw</p>				

Figure 3: Types of Relays

06050

### 3. ELECTRICAL COMPARTMENTS AND JUNCTION BOXES

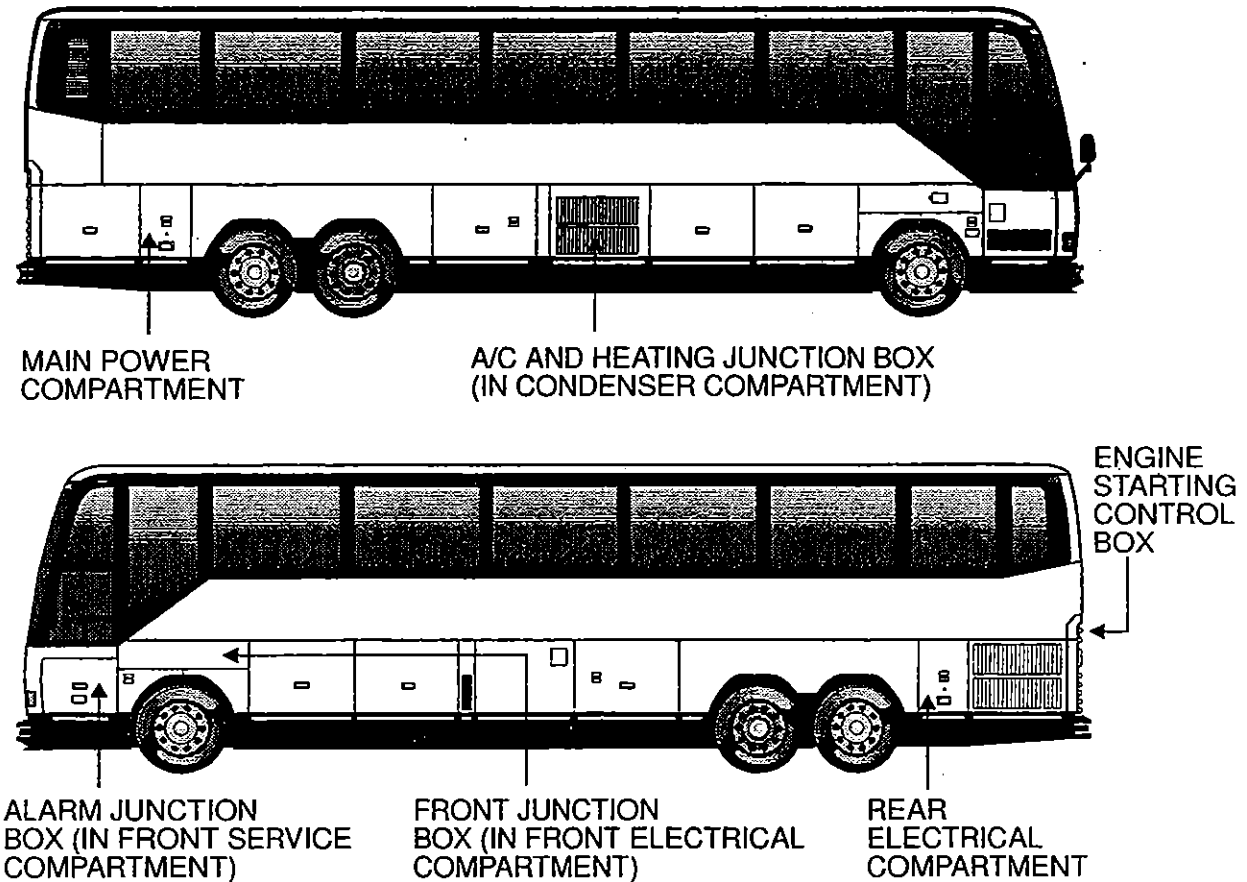

Figure 4

06051

#### 3.1 Maintenance

A Cortec VCI-238 corrosion inhibitor has been sprayed in all electrical compartments to protect components from corrosion. The life expectancy of this product is five years, so it is recommended to reapply it every five years. It is also recommended to spray it on new components when added or replaced.

**Warning:** Use VCI-238 in a well ventilated area. Do not smoke. Avoid prolonged contact with skin and breathing of spray mist. Harmful or fatal if swallowed. Do not induce vomiting. Call physician immediately.

### 3.2 Main Electrical Compartment

The main electrical compartment is located on rear R.H. side of vehicle aft the rear wheelhousing. This compartment contains the following components (fig. 5 and 6):

- four batteries;
- main circuit breakers;
- voltage regulator;
- battery equalizer;
- electric system monitor;
- main battery relays (safety switch);
- battery booster block.

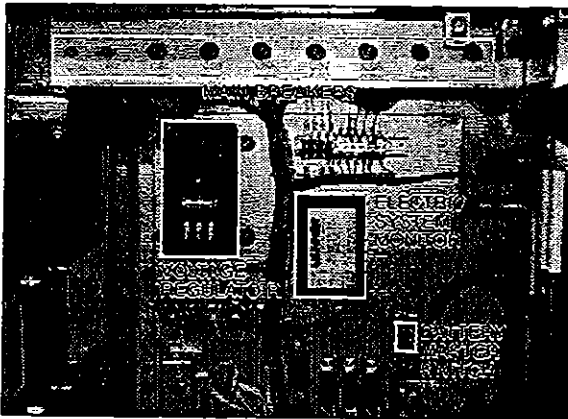

Figure 5

06052

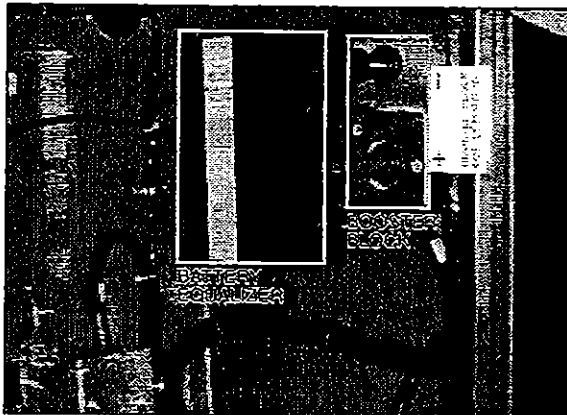

Figure 6

06053

### 3.3 Rear Electrical Compartment and Junction Box

The rear electrical compartment is located on L.H. side of vehicle aft the rear wheelhousing. It contains the rear junction box with the following components (fig. 7 and 8):

- ECU (Electronic Control Module) for Allison World Transmission;
- vehicle interface module;
- secondary circuit breaker;
- relays;
- programmable speed switch.

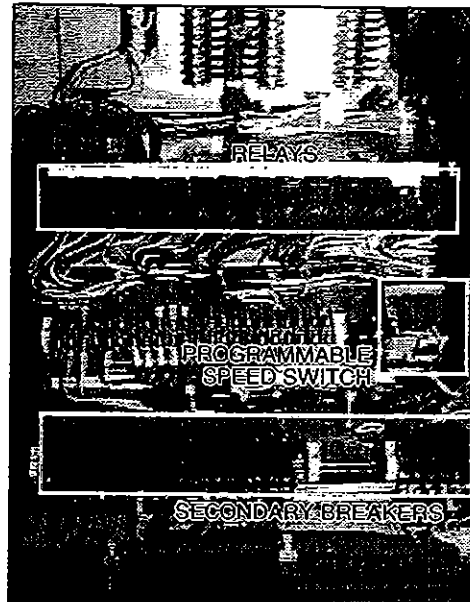

Figure 7

06054

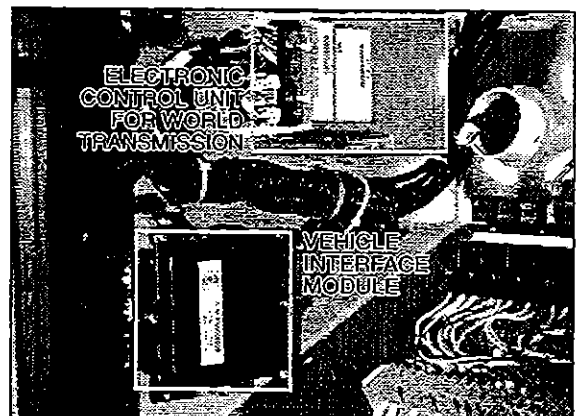

Figure 8

06055

### 3.4 Front Electrical Compartment and Junction Box

The front electrical compartment is located on L.H. side of vehicle, over the front axle. It contains the front junction box with the following components:

#### Left Section (fig. 9)

- ECU for Antilock Braking system;
- blinker switch;
- relays;
- junctions and connectors.

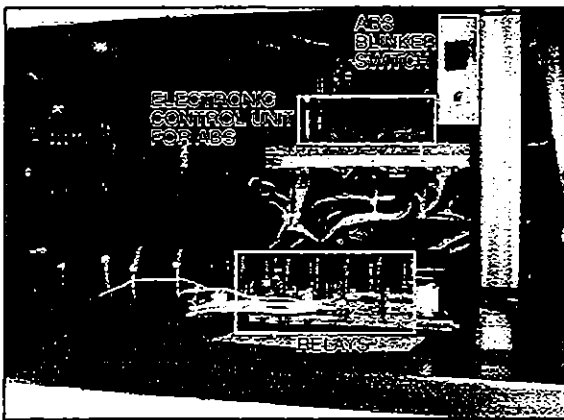

Figure 9 06056

#### On Front Junction Box (fig. 10)

- secondary circuit breakers;
- relays;
- resistors;
- electronic flasher unit.

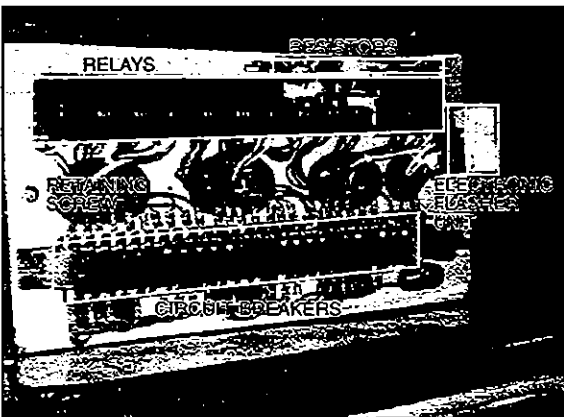

Figure 10 06057

#### In Front Junction Box (fig. 11)

To open front junction box, unscrew 1/4 turn the retaining screw.

- secondary circuit breakers;
- relays.

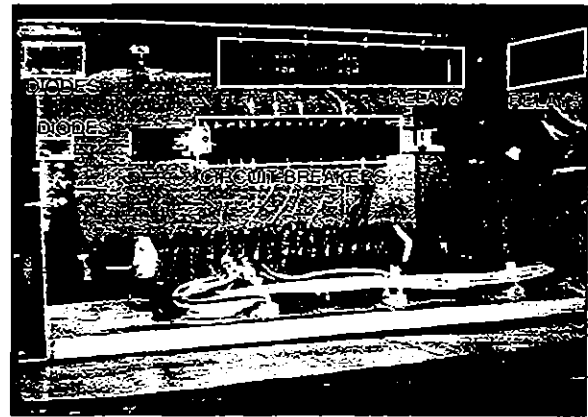

Figure 11 06058

### 3.5 Alarm Junction Box

The alarm junction box is located in the front service compartment, under the driver's window. To gain access, open the front service compartment door. This junction box contains the following items:

#### On Alarm Junction Box (fig. 12)

- fire alarm;
- passenger chime (bus only);
- alarm units;
- pulse generator for windshield wiper motor;
- diodes;
- 120 volts inlet (in-station lighting, bus only).

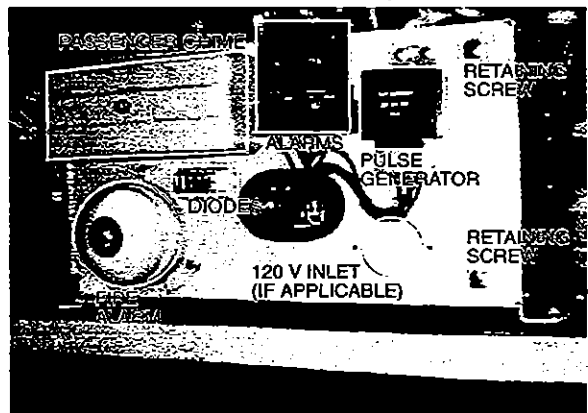

Figure 12 06059

### In Alarm Junction Box (fig. 13)

To open alarm junction box, unscrew two 1/4 turn retaining screws.

- dash lights regulator;
- junctions and terminals.

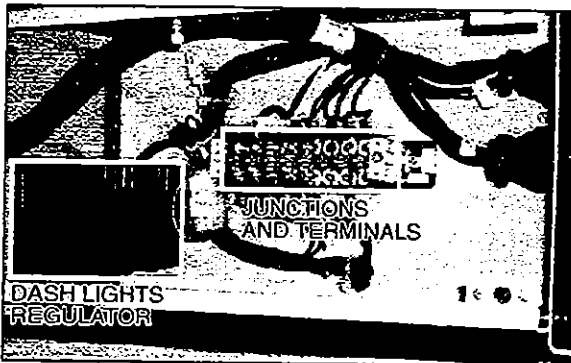

Figure 13

06060

## 3.6 Engine Starting Control Box

This control box is located in the R.H. side of engine compartment near the engine oil reserve tank. This junction box includes the engine starter selector switch, as well as the rear start push button switch to start engine from engine compartment.

## 3.7 A/C and Heating Junction Box

The A/C and heating junction box is located inside condenser compartment. For maintenance purpose, this junction box has a sliding drawer which includes the A/C logic panel (W973B module), the electronic transmitter (T7067B printed circuit board), the A/C logic and control modules and some fuses. Open the second (H3-41) or third (H3-45) R.H. baggage compartment door then, unscrew the quarter turn screw and slide open the drawer. Refer to figure 14 for details.

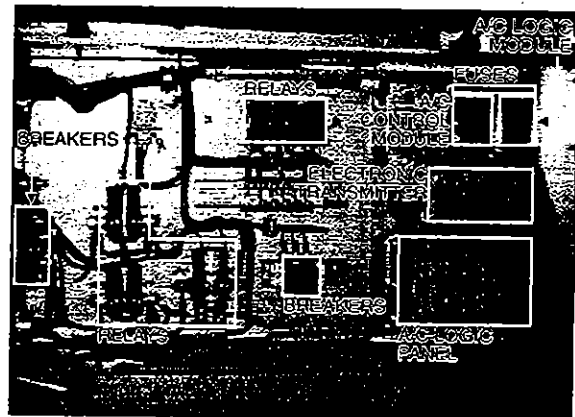

Figure 14

06061

**Note:** It is important when checking the A/C and heating system to keep the condenser compartment door closed in order to avoid faulty readings. Open the sliding drawer as indicated to verify the system.

The complete junction box is accessible by opening the condenser compartment door. Remove the four (4) rubber latches, then remove the cover. This junction box includes the relays of the evaporator fan motor and condenser speed controls, as well as the circuit breakers and relays of the A/C logic panel, A/C compressor clutch, water pump and condenser fan motors. Furthermore, a diode for the preheater water pump signal is installed in this junction box, regardless if the vehicle is provided with or without this optional system. Refer to figure 15.



Figure 15

06062

## 4. BATTERIES

### 4.1 General Description

The vehicle is provided with four (4) maintenance-free 12 volt heavy-duty batteries connected in series-parallel. The top-mounted negative and positive terminals are tightly sealed to prevent leaks. Water never needs to be added to this type of battery. There are no filler caps in the cover. The battery is sealed, except for small vent holes in the cover. The vents must not be restricted as they allow small amount of gases that are produced in the battery to escape. The special chemical composition inside the battery reduces gassing to a very small amount at normal charging voltages. Besides reducing gassing, the special chemistry greatly reduces the possibility of overcharge damage.

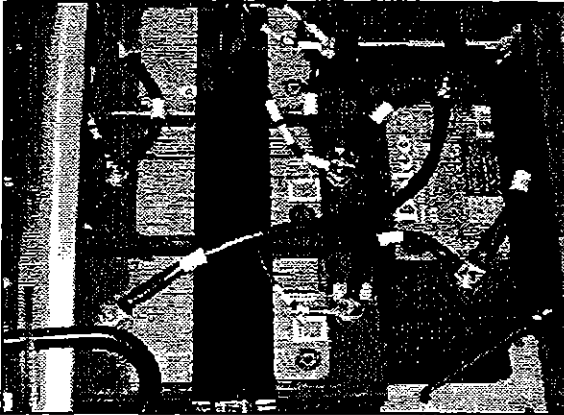

Figure 16

06063

The vents require keeping the battery in an upright position to prevent electrolyte leakage. Tipping the battery beyond a 45° angle in any direction can allow a small amount of electrolyte to leak out of the vent holes.

**Warning: DO NOT tip battery by more than 45° when carrying or installing the battery.**

Evidence of electrolyte leakage does not necessarily mean the battery is defective.

With special cables properly attached to batteries, the metal surfaces that carry the current are completely sealed from the atmosphere. This prevents terminal oxidation and corrosion that may cause starting and charging problems. If new cables are required, sealed terminal cable replacements should be used to retain the reliability of the original maintenance-free connections.

**Warning: All lead-acid batteries generate hydrogen gas which is highly flammable. If ignited by a spark or flame, the gas may explode violently, causing spraying of acid, fragmentation of the battery, and result in possible severe personal injuries. Wear safety glasses when working near batteries. In case of contact with acid, flush immediately with water.**

The battery has four (4) major functions:

1. Providing a source of current for starting the engine.
2. Stabilizing the voltage in the electrical system.
3. Supplying current for a limited time, when electrical demands of the equipment exceed the power output of the alternator.
4. Providing a limited source of power for connected accessories, when the engine is not running.

### 4.2 Main Battery Relays

Main battery relays (12 V. and 24 V.) are provided for this vehicle. The relays are located in main electrical compartment. The 24 volt battery relay is actuated by two master switches connected in series, the first one located in main electrical compartment (refer to fig. 5), and the second one located on the dashboard.

When the main battery relays are turned to the "Off" position, all electrical supply from the batteries is cut off, with the exception of the following items:

- Tachograph clock;
- Battery equalizer check module;
- ECM ignition and power supply;
- ECU power (World transmission);
- Preheater electronic timer;
- Preheater and water recirculating pump;
- Sedan entrance door;
- Prodriver;
- Powerverter;
- Sound system.

### 4.3 Battery Removal and Installation

1. Remove the two screws at the bottom of the plastic protective cover. Unscrew the two quarter turn nuts to remove the protective cover.
2. Remove supports. Unscrew terminal nuts of each defective battery.



**Note:** Battery main relays should be in the "Off" position before disconnecting cables from the batteries.

3. Remove battery cables from the batteries.

**Note:** When the battery cables have been removed from the batteries, wrap the battery terminals and cable ends with electric tape to prevent accidental grounding. The ground cables should always be disconnected first and replaced last.

4. Remove batteries.

5. Installation is the reverse of removal.

**Note:** In replacing batteries, only batteries of the same specification should be used. Refer to "Specifications" at the end of this section for further details.

**Caution:** Ensure that connections are not reversed when reinstalling batteries, since damage to electrical system components will result.

When reinstalling batteries, battery connections must be torqued to 10-15 ft•lbs (13-20 N•m) and the nut on top of sliding tray to 45-55 in•lbs (5-6 N•m). A torque wrench is required to ensure an accurate tightening torque.

**Warning:** To prevent possible electric shocks or sparking, the battery main relays must be set to the "Off" position before tightening an electrical connection.

**Note:** A protective coating should be applied on all terminals that have been disconnected, and this coating should be clear of silicone. We recommend the use of Cortec VCI-238 (Prévost part #68-2460) on all electrical connections.

## 4.4 Battery Rating

Each of the 12 volt batteries used on the vehicle has the following rating:

- Reserve capacity: 180 minutes
- Cold cranking (amps): 625 @ 0 °F (-18 °C)
- Cold cranking (amps): 490 @ -20 °F (-29 °C)
- Weight filled: 59 lbs (26,7 kg)

The reserve capacity is defined as the number of minutes a new, fully charged battery at 80 °F (26,6 °C) can be discharged at 25 amperes and maintain a minimum of 1.75 volts per cell (10.5 volts total for one 12 volt battery). This rating can be used

as a basis for determining how long a vehicle might run after an alternator failure.

The cold cranking rating is defined as the minimum discharge current a battery will deliver in amperes for 30 seconds at 0 °F (-18 °C) while maintaining a minimum of 1.2 volts per cell (7.2 volts total for one 12 volt battery). This rating can be used as a basis for comparing starting performance.

## 4.5 Battery Testing

The maintenance-free battery has a strong ability to withstand the damaging effects of overcharge. The test indicator in the cover is used only to determine if the battery can be tested in case of a cranking problem.

The test indicator in the battery cover is to be used with accepted diagnostic procedures only. It must not be used to determine if the battery is good or bad, or charged or discharged. The test indicator is a built-in hydrometer in one cell which provides visual information for battery testing.

It is important when observing the test indicator, that the battery be relatively level and has a clean indicator top to see the correct indication. A light may be required in some poorly lit areas. Under normal operation, two indications can be observed.

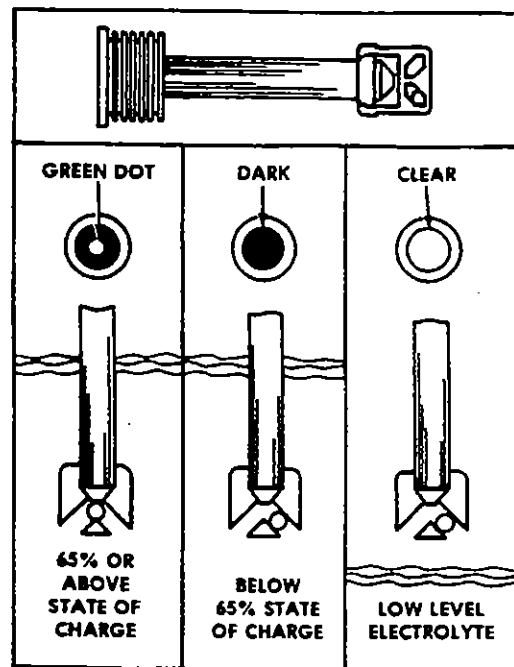

Figure 17

06096

**Green Dot Visible**

Any green appearance is interpreted as a "green dot", and the battery is ready for testing. On rare occasions, following prolonged cranking, the green dot may still be visible when the battery is obviously discharged. Should this occur, charge the battery as described under "Charging Procedure" in "Battery Charging" later in this section.

**Dark - Green Dot Not Visible**

If there is difficulty cranking the engine, the battery should be tested as described in this section. On rare occasions, the test indicator may turn light yellow. In this case, the integral charging system should be checked. Normally, the battery is capable of further service; however, if difficult start has been reported, replace the battery. **DO NOT CHARGE, TEST, OR JUMP-START.**

**4.5.1 Visual Inspection**

1. Check the outside of the battery for a broken or cracked cover or case that could permit loss of electrolyte. If obvious physical damage is noted, replace the battery.
2. Check for loose terminal posts, cable connections, damaged cables, and for evidence of corrosion. Correct conditions as required before proceeding with tests.

**4.5.2 Removing Surface Charge**

Disconnect cables from the battery and attach alligator clamps to the contact lead pad on the battery as shown in figure 19. Connect a 300 ampere load across the terminal for 15 seconds to remove surface charge from the battery.

**4.5.3 Load Test**

This test is one means of checking the battery to determine its ability to function as required in the vehicle.

To make this test, use test equipment that will withstand a heavy electrical load from the battery, such as a carbon pile resistor or other suitable means.

1. Connect a voltmeter, ammeter, and a variable load resistance as illustrated in figure 18.

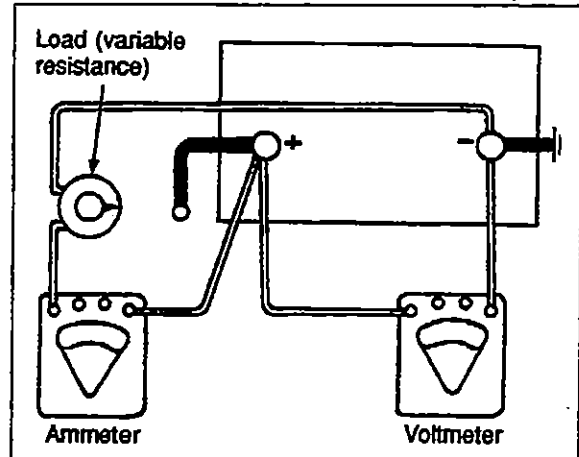

Figure 18

06064

**Caution:** Observe polarity of the meters and the battery when making connections, and select the correct meter range.

2. Apply a 290 ampere load to the battery for 15 seconds.
3. With an ammeter reading specified load, read voltage. The voltage should be at least 9.6 volts. Disconnect the load. If the voltmeter indicates 9.6 volts or more, the battery is good. If the voltmeter reading is less than 9.6 volts, replace the battery. This voltage is to be used for battery ambient temperatures of 70 °F (21 °C) and above. For temperatures below 70 °F (21 °C), refer to the following "Voltage and Temperature Chart".

**Voltage and Temperature Chart**

Ambient Temperature	Minimum Voltage
70 °F (21 °C) and above	9.6
60 °F (16 °C)	9.5
50 °F (10 °C)	9.4
40 °F (4 °C)	9.3
30 °F (-1 °C)	9.1
20 °F (-7 °C)	8.9
10 °F (-12 °C)	8.7
0 °F (-18 °C)	8.5

**Note:** The accuracy of this test procedure is dependent upon close adherence to the proper load, time and temperature specifications.

#### 4.5.4 Testing Battery Cables

Check all cable ring terminals and connections to determine if they are in good condition. Excessive resistance, generally caused by poor connections, produces an abnormal voltage drop which may lower voltage at the starting motor to such a low value that normal operation of the starting motor will not be obtained. An abnormal voltage drop can be detected with a low-reading voltmeter as follows:

**Warning:** To prevent the engine from starting, the DDEC engine circuits, which are protected by breakers (CB-19, CB-20 and CB-21) located in the main electrical compartment, must be deenergized during these tests; afterward, depress black button to close circuit.

1. Check voltage drop between grounded (negative) battery terminal and vehicle frame by placing one prod of the voltmeter on the battery terminal and the other on a good ground (unpainted surface) on the vehicle. With the starting motor cranking the engine at a temperature of 70 °F (21 °C), voltage reading should be less than 0.3 volt. If the voltage reading exceeds 0.3 volt, there is excessive resistance in this circuit.
2. Check voltage drop between the positive battery terminal and the starting motor positive terminal stud while the motor is operated. If the reading is more than 2.5 volts, there is excessive resistance in this circuit.

**Note:** If it is necessary to extend the voltmeter lead for this test, use a #16 (AWG) or larger wire.

3. Check voltage drop between the starting motor housing and a good ground on the vehicle. The reading should be less than 0.2 volt.

**Warning:** Any procedure other than the following could cause personal injury or damage to the charging system resulting from battery explosion or electrical burns.

Wear adequate eye protection when working on or near the batteries. Ensure that metal tools or jumper cables do not contact the positive battery terminal (or a metal surface in contact with it) as a short circuit will result.

Do not attempt to jump start a vehicle suspected of having a frozen battery because the battery may rupture or explode.

Both the booster and discharged batteries must be treated carefully when using jumper cables. Follow exactly the procedure outlined later in this section, being careful not to cause sparks.

#### 4.6 Battery Charging

**Warning:** During charging of the batteries, an explosive gas mixture forms in each cell. Part of this gas escapes through the vent holes and may form an explosive atmosphere around the battery itself if ventilation is poor. This explosive gas may remain in or around the battery for several hours after it has been charged. Sparks or flames can ignite this gas causing an internal explosion which may shatter the battery.

1. Do not smoke near a battery which is being charged or which has been recently charged.

2. Do not break live circuits at battery terminals because a spark usually occurs at the point where a live circuit is broken. Care must always be taken when connecting or disconnecting booster leads or cable clamps on chargers. Poor connections are a common cause of electric arcs which cause explosions.

3. The electrical system on this vehicle is negative ground. Installing the batteries with the positive terminals grounded or incorrect use of the booster battery and jumper cables will result in serious damage to the alternator, batteries and battery cables.

##### 4.6.1 Charging Procedure

The batteries used on this vehicle can be charged either on or off the vehicle; however, when they are removed from the vehicle, it is recommended that an adapter kit, which is available from any "A/C DELCO" dealer, be used in charging sealed-terminal batteries. Use the booster block to charge the batteries when they are left on vehicle and make sure that the main battery disconnect switch is set to the "On" position.

The alligator clamps of the tester or charger must be placed between the terminal nuts and the lead pads of the terminal studs (fig. 19) after the vehicle cables are detached.

The alligator clamps should make firm contact with the lead pads.

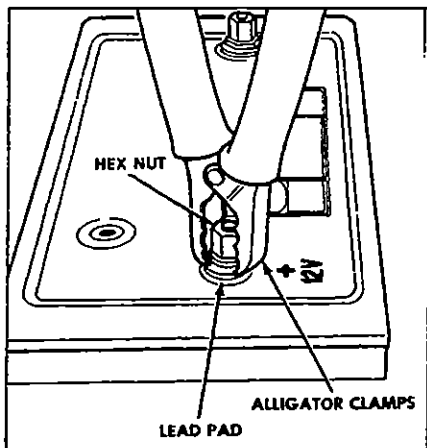

Figure 19 06065

**Note:** If this connection cannot be made because of the alligator clamp design, the load value for testing must be reduced from 290 to 260 amperes.

On rare occasions, such as those that occur following prolonged cranking, the green dot in the test indicator may still be visible when the battery is obviously discharged. Should this occur, a boost charge of 20 ampere-hours is recommended. Under normal operating conditions, do not charge battery if the green dot is visible. The battery should never be charged if the test indicator (hydrometer) is clear or light yellow. If this occurs, replace the battery.

A charge rate between 3 and 50 amperes is generally satisfactory for any maintenance-free battery as long as spewing of electrolyte does not occur or the battery does not feel excessively hot (over 125 °F (52 °C)). If spewing or violent gassing of electrolyte occurs, or battery temperature exceeds 125 °F (52 °C), the charging rate must be reduced or temporarily stopped to allow cooling and to avoid damaging the battery.

Battery temperature can be estimated by touching or feeling the battery case. The battery is sufficiently charged when the green dot in the built-in hydrometer is visible. No further charging is required. Shake or tilt the battery at hourly intervals during charging to mix the electrolyte and see if the green dot appears.

**Warning:** Always turn off the charger before connecting or disconnecting it to or from a battery.

**Note:** The charge rate must be doubled when the batteries are charged by the booster block, because of the series-parallel circuit.

Battery charging consists of a charge current in amperes for a period of time in hours. Thus, a 25 ampere charging rate for 2 hours would be a 50 ampere-hour charge to the battery. Most batteries, whose load test values are greater than 200 amperes, will have the green dot visible after at least a 75 ampere-hour charge. In the event that the green dot does not appear, replace the battery.

## 4.6.2 Battery Charging Guide

### Fast Charging Rate

20 amps @ 3-3/4 hours  
 30 amps @ 2-1/2 hours  
 40 amps @ 2 hours  
 50 amps @ 1-1/2 hours

### Slow Charging Rate

5 amps @ 15 hours  
 10 amps @ 7-1/2 hours

The time required for a charge will vary according to the following factors:

#### Size of Battery

For example, a completely discharged large heavy-duty battery requires more than twice the recharging time of a completely discharged small passenger car battery.

#### Temperature

For example, a longer time will be needed to charge any battery at 0 °F (-18 °C) than at 80 °F (27 °C). When a fast charger is connected to a cold battery, the current accepted by the battery will be very low at first, then in time, the battery will accept a higher rate as it warms up.

#### State of Charge

For example, a completely discharged battery requires more than twice as much charge than a half-charged battery. Since the electrolyte is nearly pure water and a poor conductor in a completely discharged battery, the current accepted is very low at first. Later, as the charging current causes the electrolyte acid content to increase, the charging current will likewise increase.

#### Charger Capacity

For example, a charger which can supply only 5 amperes will require a much longer period of charg-

ing than a charger that can supply 30 amperes or more.

#### 4.6.3 Emergency Jump Starting With Auxiliary (Booster) Battery

**Warning:** Do not jump start vehicles equipped with maintenance-free batteries if the test indicator is light yellow.

Both booster and discharged batteries should be treated carefully when using jumper cables. A vehicle with a discharged battery may be started by using energy from a booster battery or the battery from another vehicle.

**Warning:** Jump starting may be dangerous and should be attempted only if the following conditions are met:

The booster battery or the battery in the other vehicle must be of the same voltage as the battery in the vehicle being started, and must be negative grounded.

If the booster battery is a sealed-type battery without filler openings or caps, its test indicator must be dark or a green dot must be visible. Do not attempt jump starting if the test indicator of the booster battery or the discharged battery has a light or bright center.

**Warning:** Follow the procedure exactly as outlined hereafter. Avoid making sparks.

1. Wear eye protection and remove rings, watches with metal bands and other metal jewelry.
2. Apply parking brake and place the transmission shift lever or push-button pads in Neutral (N) position in both vehicles. Turn off lights, heater and other electrical loads. Observe the charge indicator. If the indicator in the discharged battery is illuminated, replace the battery. Do not attempt jump starting when indicator is illuminated. If the test indicator is dark and has a green dot in the center, failure to start is not due to a discharged battery and the cranking system should be checked. If charge indicator is dark but the green dot does not appear in center, proceed as follows:
3. Connect one end of one red jumper cable to the positive (+) terminal of the booster power source and the other end to the positive (+) post of the booster power block, located in the main electrical compartment (refer to fig. 6).
4. Connect one end of the remaining negative jumper cable (black) to the negative (-) terminal

of the booster power source, and the other end of the black jumper cable to the negative (-) post of the booster power block.

5. Make sure the clips from one cable do not inadvertently touch the clips on the other cable. Do not lean over the battery when making connections. The ground connection must provide good electrical conductivity and current carrying capacity.
6. Start the engine in the vehicle that is providing the jump start. Let the engine run for a few minutes, then start the engine in the vehicle that has the discharged batteries.
7. When removing the jumper cables, perform the above procedure exactly in reverse order, and replace protective caps on booster block terminals.

**Warning:** Any procedure other than the above could result in personal injury, property damage due to battery explosion, or damage to the charging system of the booster vehicle or of the boosted vehicle.

**Note:** Jumper cables must withstand 500 cranking amperes. If cable length is 20 feet (6 m) or less, use 2/0 (AWG) gauge wires. If cable length is between 20-30 feet (6-9 m), use 3/0 (AWG) wires.

#### 4.7 Cleaning and Inspection

The external condition of the battery and the battery cables should be checked periodically. The top of the battery should be kept clean and the battery hold-down clamp bolts should be kept properly tightened. For best results when cleaning the battery, wash first with a diluted solution of ammonia or soda to neutralize any acid present, then wash out with clean water. The battery hold-down bolts should be kept tight enough to prevent the batteries from moving, but they should not be tightened to the point that excessive strain is placed on the battery hold-down cover (proper tightening torque: 45-55 in•lbs (5-6 N•m)).

To insure good contact, the battery cable ring terminals should be tight on the battery posts. If the posts or cable ring terminals are corroded, the cables should be disconnected and the posts and clamps cleaned separately with a soda solution and a wire brush. Install cable ring terminals on battery posts and tighten to a torque of 10-15 ft•lbs (13-20 N•m). Replace protective caps to prevent corrosion and sparks.

## 4.8 Common Causes of Battery Failure

When a battery fails, the cause of failure may be related to something other than the battery. For this reason, when a battery failure occurs, do not be satisfied with merely recharging or replacing the battery. Locate and correct the cause of the failure to prevent recurrence. Some common external causes of battery failure are as follows:

1. A defect in charging system such as high resistance or a faulty alternator or regulator.
2. A malfunction within the 12 volt system (equalizer).
3. Overloads caused by a defective starter or excessive use of accessories.
4. Dirt and electrolyte on top of the batteries causing a constant drain.
5. Hardened battery plates, due to battery being in a low state of charge over a long period of time.
6. Shorted cells, loss of active material from plates.
7. Driving conditions or requirements under which the vehicle is driven for short periods of time.
8. A constant drain caused by a shorted circuit such as an exposed wire or water infiltration in junction boxes causing ground fault.
9. Extended operation of preheating system with engine not running.
10. Failing to close disconnect switches during the night.

## 4.9 Troubleshooting

If a battery is known to be good and then has not performed satisfactorily in service for no apparent reason, the following factors may reveal the cause of trouble:

1. Vehicle accessories and disconnect switches inadvertently left on overnight.
2. Defects in the charging system, such as high wiring resistance, faulty alternator, regulator or battery equalizer.
3. A vehicle electrical load exceeding the alternator (or battery equalizer) capacity, with the addition of electrical devices, such as CB radio equipment, a cellular phone or additional lighting systems.

4. Defects in the electrical system, such as shorted or pinched wires.
5. Extended driving at a slow speed while using many accessories.
6. Loose or poor battery cable-to-post connections, previous improper charging of a run-down battery, or loose hold-down clamp bolts.
7. High-resistance connections or defects in the cranking system.

## 5. ELECTRICAL SYSTEM MONITOR

This vehicle is equipped with an electronic device that monitors and detects an abnormal alternator, voltage regulator, battery banks or battery equalizers conditions. The monitor is installed on back wall of the main electric compartment (refer to fig. 5). The "Battery balance" and "Battery Hi/Lo" warning lamps connected to this module are mounted in dashboard (refer to "Operator's Manual" for location). If a malfunction should occur, the monitor sends a signal to the driver through the warning light of the malfunctioning component. If the "Battery Hi/Lo" warning light is illuminated, check the 24 volt voltmeter to determine if battery voltage is too high or too low.

**Note:** According to battery charging condition, it is normal that "Battery Hi/Lo" warning light illuminates upon starting the engine and stays illuminated for a few seconds. This is caused by the normal voltage drop of the battery during starting.

## 5.1 Warning Lamp Definitions

### 5.1.1 Battery Hi/Lo

Voltmeter drops below 24 V dc

- Check alternator output.
- Check voltage regulator.
- Check battery connections.
- Check battery cells.
- Check battery equalizer connections.

Voltmeter exceeds 30 V dc

- Check alternator output.
- Check voltage regulator.
- Check battery connections.

### 5.1.2 Battery Balance

**Note:** Allow at least 15 minutes to balance batteries after any corrective measure has been taken.

1. Batteries out of balance (difference greater than 1.5 volts between the two battery banks)
  - Check battery equalizer connections.
  - Check equalizer cables for proper gauge.
  - Check battery connections.
2. Demand for 12 volt power exceeding rated amperage output of battery equalizers causing batteries to go out of balance
  - Reduce 12 volt load or install additional battery equalizer(s).

### 5.1.3 "Battery" Warning Light

This warning light is not controlled by the electronic monitor, but by the "R" terminal of the alternator using the normally-closed contact of the relay "R-33". If a voltage drop should occur in the charging system, the "Battery" warning light will immediately light up to warn the driver and will be followed by the illumination of the "Battery Hi/Lo" warning light if the voltage drops below 24 V dc.

Refer to heading "Diagnosis of charging system problems" later in this section, to determine whether the alternator or the voltage regulator is defective. Should the "Battery" warning light illuminate while the 24 volt voltmeter keeps on giving a normal reading and the "Battery Hi/Lo" warning light does not illuminate, the relay R-33 or its wiring is probably defective.

**Caution:** The relay R-33 should never be replaced with a relay provided with a suppressor diode on its coil as the output current (between 12 and 14 volts) at the alternator "R" terminal is not rectified, thus rendering relay inoperative.

**Note:** When the "Battery" warning light illuminates, the "A/C & Heating" system shuts off in order to prevent battery discharge.

## 6. ALTERNATOR

The 24 volt charging system consists of a belt driven, oil-cooled, brushless alternator, a 24 volt voltage regulator, an alternator relay and a 12 volt system that includes a 12 volt, 100 amp equalizer. The components used in this system are described under the applicable headings hereafter.

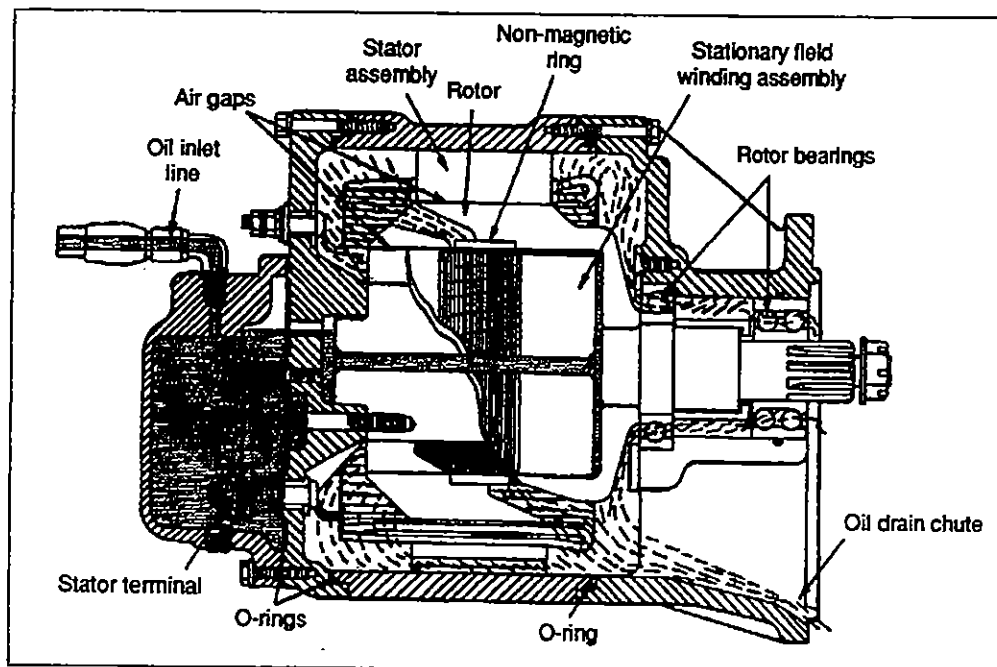

Figure 20

06066

This oil-cooled alternator is self-rectifying. All current carrying members, windings, built-in diodes, and field coils are stationary. The only moving component is the rotor. The alternator is a totally-enclosed unit, cooled and lubricated by engine oil. The oil inlet is on the diode end cover. The oil drains back into the engine crankcase through the drive end frame and drive adapter housing. The alternator should never be operated

with the oil supply line disconnected. A continuous flow of engine oil flows through the alternator to lubricate the bearings and cool the assembly.

Four terminals are used on this alternator: the DC output terminal, two field terminals, and a 12 volt relay terminal. The alternator output voltage is regulated by a separate 24 volt regulator that controls the alternator field current.

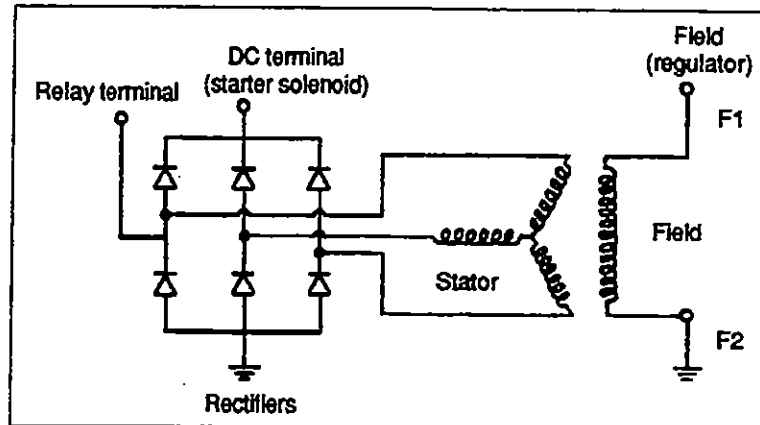

Figure 21: Alternator Wiring Diagram

06067

**Note:** The relay coils connected to the alternator "relay terminal" **SHOULD NEVER BE PROVIDED WITH A SUPPRESSOR DIODE** as the output current at this terminal is not rectified, thus rendering relay inoperative.

**Caution:** The electrical system is **NEGATIVE GROUND**. Connecting the batteries or a battery charger with the positive terminal grounded will endanger the alternator diodes and vehicle wiring by a high current flow. Burned wiring harness and burned "open" diodes will result. Always ensure that the alternator and battery polarities are matched prior to installation. **THE ALTERNATOR WILL NOT REVERSE TO ACCEPT INVERSE POLARITY.** Also, do not ground or short across any of the alternator or regulator terminals.

Since there are no brushes, slip rings, or rubbing seals, the alternator requires no periodic maintenance other than the following:

1. Check alternator-to-engine mounting bolts for looseness and tighten to the proper torque.

2. Check all electrical connections for tightness and corrosion. Clean and tighten connections as necessary. Be sure wiring insulation is in good condition and that all wiring is securely clipped to prevent chafing of the insulation.

3. With the engine running, listen for noise and check the alternator for vibration. If the alternator is noisy or vibrates excessively, it should be removed for inspection and repair.

4. Ensure that battery terminals are clean and tight.

## 6.1 Diagnosis of Charging System Problems

The troubleshooting of the charging system is made easier by the use of a 12 and a 24 volt voltmeter, "Battery", "Battery balance" and "Battery Hi/Lo" warning lights mounted in the dashboard (for location refer to the "Operator's Manual"). The definition of each warning light is explained under the heading "5. Electrical System Monitor".



### 6.1.1 Alternator or Voltage Regulator

To determine which unit is faulty, proceed as follows:

1. Start the engine and momentarily connect a jumper from the "F1" field terminal to "DC (+)" terminal. For connections, refer to figure 22.

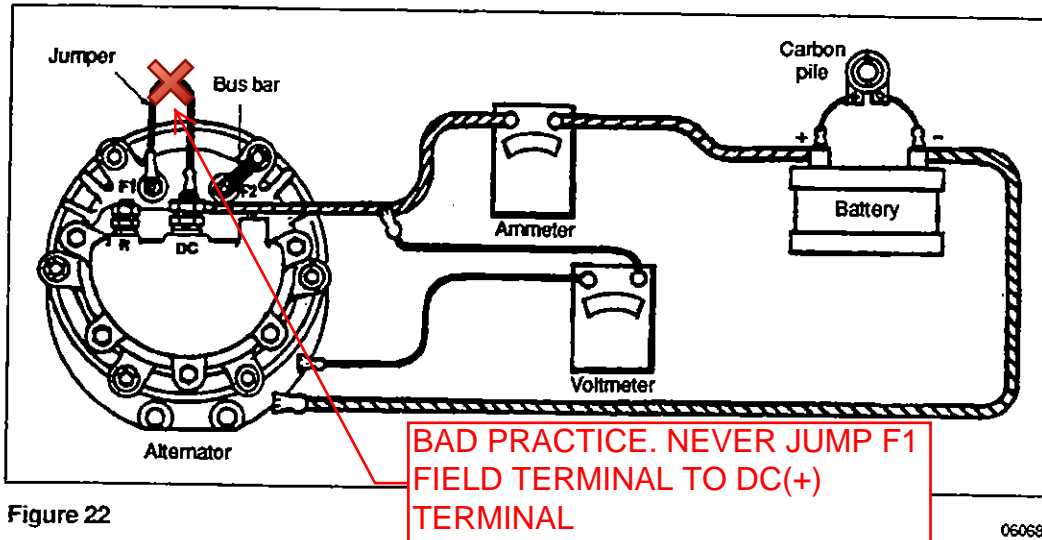

Figure 22

~~**Caution:** Do not feed the alternator field "F1" terminal for more than 10 seconds. High voltage could burn out the wires and components of charging system, and seriously damage the alternator.~~

~~Do not jump the "F2 (-)" terminal with the "DC (+)" terminal on the alternator. This will result in a direct short circuit.~~

- a) If the voltmeter readings increase, trouble is located in the 24 volt regulator or wiring. Check the regulator as explained under the heading "Voltage Regulator", later in this section.
- b) If the voltmeter readings do not increase, the problem may be in the alternator.

## 6.2 Alternator Diagnosis

**Caution:** Before checking the alternator, TURN OFF the battery main disconnect switch.

It is not necessary to completely disassemble the alternator to make electrical checks. All electrical checks are made at the diode end of the assembly without having to remove the rotor, drive end frame, or bearing. If the electrical components are not

defective, but bearing replacement is necessary, this can be done at the drive end without having to disassemble the diode end of the unit.

The components in the alternator which require electrical checks are the field winding, the six diodes, and the stator winding.

### 6.2.1 Diode Checks

Each diode may be checked for shorts and opens as follows:

1. Ensure the battery main disconnect switch is set to the "OFF" position.
2. Remove the pipe plug from underneath the end housing to drain the oil in the rectifier engine oil supply.
3. Remove the cap screws (7) and lock washers which attach the diode end cover to the end housing. Remove the end cover from the end housing.

**Note:** Do not operate the alternator unless this unit is completely reassembled.

4. Remove seal from the end housing, detach and remove "DC" and relay terminals, stud, insulating sleeves and O-rings.

Section 6: ELECTRICAL SYSTEM

5. Disconnect all diode flexible leads; i.e. three from the output terminal stud and three from the diode supports. See figure 23 for more details.

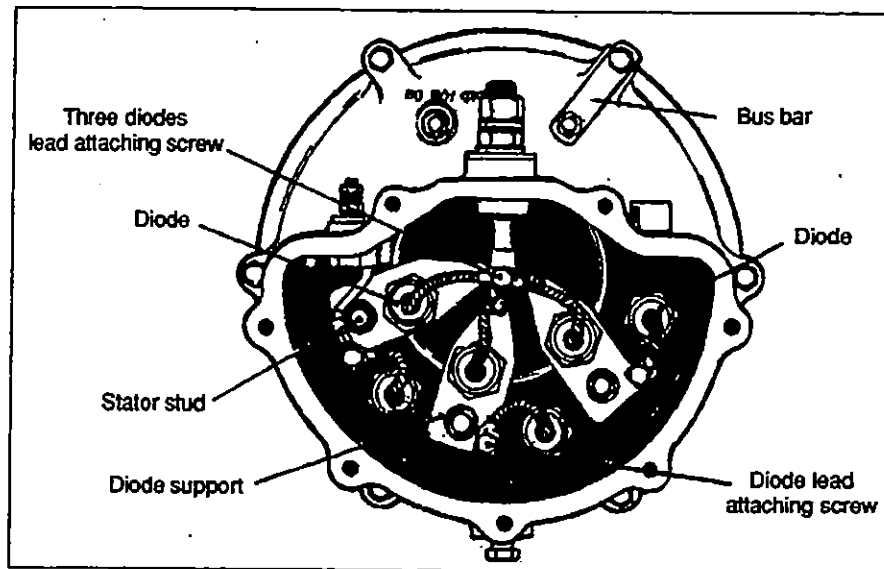

Figure 23

06069

Each diode may be checked for short or open circuits with an ohmmeter.

**Note:** The ohmmeter polarity may be determined by connecting its leads to the voltmeter leads. The voltmeter will read up-scale when the negative leads are connected together and the positive leads are connected together. The polarity of the voltmeter leads may be determined by connecting the leads to the identified terminals on a battery.

**Note:** Use an ohmmeter with a single 1.5 volt cell. The most accurate reading will be determined when the 300 ohm value is calibrated to the center one-third of the scale. DO NOT USE high voltage, such as a 110 volt test lamp to check diodes.

To check diodes mounted in the supports for short fields, connect the positive ohmmeter lead to each diode lead and the ohmmeter negative lead to each support as shown in "A", "B", and "C" of figure 24. To check diodes mounted in the end frame for short fields, connect the ohmmeter positive lead to each diode lead and the ohmmeter negative lead to the end frame as shown in parts "D", "E", "F". The ohmmeter readings may vary considerably when checking diodes for shorts, but if the reading is 300 ohms or less, the diode is probably defective and should be replaced. If the diode reads 300 ohms or

less, it will allow excessive reverse current from the battery. Replace defective diodes as explained later in this section.

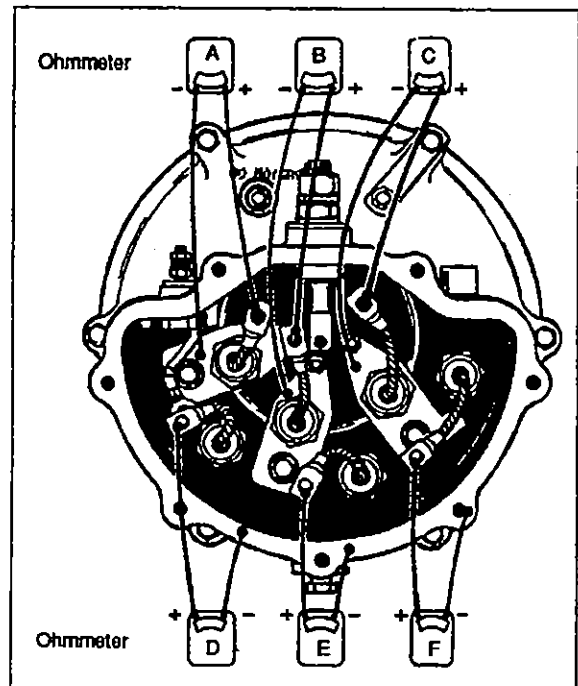

Figure 24

06070

To check the diodes mounted in the diode supports for open fields, connect the ohmmeter negative lead to each diode lead and the ohmmeter positive lead to each support as shown in parts "A", "B", and "C" of figure 25. To check the diodes mounted in end frame for shorts, connect the ohmmeter negative lead to each diode lead and the ohmmeter positive lead to the end frame as shown in parts "D", "E" and "F". An infinite resistance reading indicates an open diode. Diodes can be replaced by following the procedure outlined under the headings "Disassembly" and "Reassembly".

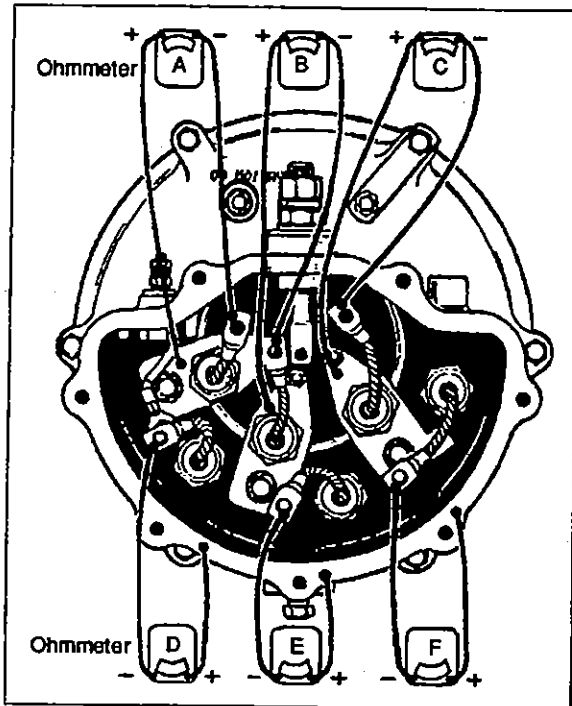

Figure 25

06071

When reinstalling diodes, torque to 9-11 lbf·ft (12-15 N·m). Re-stake next to the threads in an arbor press with an 1/8 inch (3,2 mm) round punch. Press the punch with gradual pressure. Do not strike as the shock may damage the diodes.

### 6.2.2 Field Winding

The field winding may be checked for short and open fields with an ohmmeter. To check the field winding, connect the ohmmeter to field terminal and to ground. A resistance reading above normal indicates an open, and a reading less than normal indicates a short field. The normal resistance value is 3.0 to 3.3 ohms at 80 °F (27 °C). An alternate method of checking is to place a battery, of a speci-

fied voltage, and an ammeter in series with the field winding. The current should register 7.2 to 8.3 amperes at 24 volts. Coil resistance is approximately 3.1 ohms. Amperage readings, other than the above, indicate an open, grounded, or shorted field. A defective field coil can be replaced by removing the end frame on which the field terminal is located and then removing the four field coil mounting screws. See the headings "Disassembly" and "Reassembly" for a detailed procedure.

### 6.2.3 Stator Winding

The stator winding may be checked for open and short fields with an ohmmeter as follows:

#### Open Fields

Connect the ohmmeter leads to two pairs of diode supports as shown in parts "A", "B", and "C" of figure 26. Correct polarity of the leads must be observed. The ohmmeter should indicate a low resistance. If an infinite or a high resistance is measured in either one or both checks, the stator windings are open.

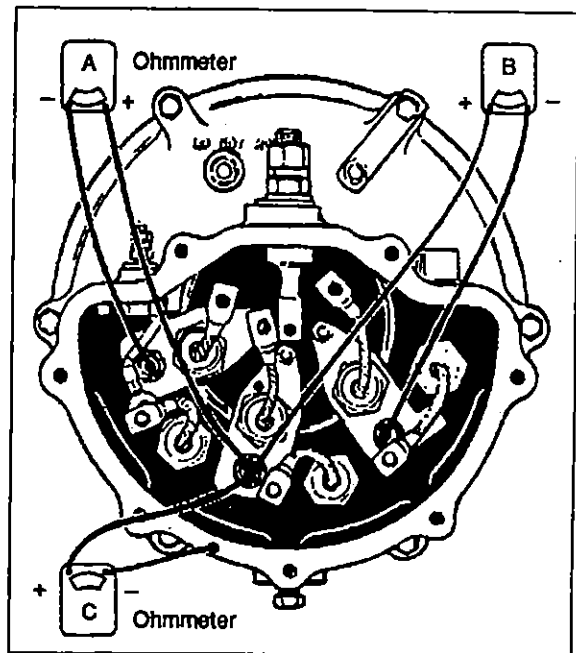

Figure 26

06072

#### Ground

To check the stator windings for ground, connect an ohmmeter to the diode support and diode end frame as shown in part "C" of figure 25. The ohmmeter should indicate a very high or infinite resistance.

If zero, or a very low resistance is measured, the windings are grounded.

### Short Fields

The stator windings are difficult to check for short fields without finely calibrated laboratory test equipment due to the very low resistance values of the windings. However, if all other alternator checks are satisfactory, yet the unit fails to perform to specifications, shorted stator windings are probable.

## 6.3 Diode Replacement

The following replacement procedures are based on the assumption that the diode end cover is still off and diode leads were disconnected as explained earlier in this section.

**Note:** When replacing a diode, make sure it is designed for a negative ground system. The diode can be identified by the symbol stamped on the diode case. The arrow must point toward the diode flexible lead.

To replace the three diodes which are mounted in the supports attached to the stator lead studs, it is necessary to remove the diode and support assembly. The two outer diode and support assemblies are identical and can be installed on either side. The center unit has a different support, with 2 inches (50,8 mm) between the mounting hole centers.

**Note:** The outer supports are provided with 2 1/4" (57,15 mm) center holes.

### 6.3.1 Diode Replacement (in Support)

1. Remove nut with lock washer attaching the diode support to the stator lead stud.
2. Remove nut, lock washer, and flat washer attaching support to the small stud in the end frame.
3. Remove the diode and support assembly. Then remove insert from small hole in support or from small stud in the end frame.
4. Remove nut and flat washer from diode mounting stud, then remove diode from the support.
5. Place a new diode in the support and install a flat washer and nut on the diode mounting stud. Hold the diode with a wrench placed over flats on the diode, while tightening nut on the mounting stud to a torque of 160-180 lb•in (18-20 N•m).
6. Place diode and support assembly over the stator lead stud and the small mounting stud.

Place insert over small stud inside the hole in the support. Install flat washer, lock washer, and nut on the small stud, and tighten to a torque of 22-25 lb•in (2-3 N•m). Install nut with lock washer on stator lead stud and tighten firmly.

### 6.3.2 Diode Replacement (in End Frame)

To remove diode, use a thin 1 inch open end wrench on flats of the diode case to unscrew diode from the end frame. Thread the new diode into the end frame and tighten to a torque of 160-180 in•lbs (18-20 N•m). If no other parts are to be replaced, refer to "Diode End Cover Installation" later in this section.

## 6.4 Field Replacement

### 6.4.1 Removal

1. Remove the three diode and support assemblies from the end frame to provide access to the two lower field to end frame bolts.
2. Remove nut with lock washer and flat washer from three stator lead studs.
3. Remove the six bolts and lock washers attaching the diode end frame to the stator frame.
4. Separate the end frame from the stator frame, and remove the end frame and field assembly from the rotor while pushing the stator lead studs out of the end frame.
5. Remove nut, lock washer, flat washer, and insulating washer which secure the field lead terminal stud in the end frame. Push the stud out of the end frame.
6. Remove field terminal stud insulating bushing and seal from the end frame. Remove insulating sleeve from the field terminal stud.
7. Remove the four bolts and lock washers attaching the field to the end frame.
8. To separate the field from the end frame, install four 3/8-24 x 3 inch bolts in place of the 3/8-24 x 2 inch bolts removed in step 7. Thread bolts in to even heights. Support the end frame in an arbor press. Then, using a suitable press plate to exert pressure on all four bolt heads, press the field out of the end frame.

### 6.4.2 Installation

1. Position the field assembly on the end frame. Insert four 3/8-24 x 3 inch bolts through the end

frame and thread into the field to keep holes aligned.

2. Support the end frame on an arbor press bed so that the diodes will not be damaged, and press the field into the end frame. Press in until shoulder on field coil bottoms against the end frame.
3. Remove the four guide bolts. Install four 3/8-24 x 2 inch bolts, using new lock washers to attach the field to the end frame. Tighten bolts securely.
4. Place insulating sleeve in inner side of the field terminal stud hole in the end frame, and insert the terminal stud through the sleeve. Place two O-rings and insulating bushing over the terminal stud and push into hole in the end frame. Install insulating washer, flat washer, toothed lock washer, and nut on terminal stud. Tighten firmly.
5. Install each stator lead stud in the end frame as follows: Place insulating washer over the stud and insert the stud through the end frame. Place the insulating bushing over the stud and position in end frame hole. Install flat washer, lock washer, and nut on the stud. Tighten firmly.
6. Install three diode and support assemblies on the end frame as previously directed under "Diode replacement".
7. Install a new seal in notch around end of the stator frame. Insert field into the rotor and position the end frame against the stator frame. Attach end frame to the stator frame with six bolts and lock washers. Tighten bolts firmly.
8. If no other parts require replacement, refer to "Diode end cover installation" later in this section to complete the assembly.

## 6.5 Stator Replacement

If tests performed under "Stator winding checks" earlier in this section indicated an open circuit or short in the stator, the stator and frame assembly must be replaced.

### 6.5.1 Removal

1. Remove diode end frame and field assembly as previously directed in steps 1 through 4 under "Removal" in "Field replacement" procedure.
2. Remove the six bolts and lock washers attaching the stator frame to the drive end frame.
3. Separate the stator frame from the drive end frame and remove the stator frame from the end frame and rotor.

### 6.5.2 Soldering Stator Terminal Leads

1. Using a wire brush, thoroughly clean the wire and terminal.
2. Silver solder the stator lead to the terminal using a torch.
3. Thoroughly clean the silver solder connection with a wire brush.
4. Using a high grade energized rosin flux, coat the silver soldered connection with a 80-20 tin-lead solder or pure tin solder to prevent deterioration of the silver solder by engine oil.

**Note:** *The silver solder will provide the required mechanical strength which will not be affected by temperature. The tin-lead solder will protect the silver solder connection from deterioration by engine oil.*

### 6.5.3 Installation

1. Position new seal in notch around the drive end of the stator frame.
2. Position the stator and frame assembly over the rotor against the drive end frame. Attach the stator frame to the drive end frame with six bolts and lock washers. Tighten bolts firmly.
3. Install diode end frame and field assembly as directed in steps 5, 6 and 7 under "Installation" in "Field replacement" procedure.
4. Install rectifier end cover as directed later.

## 6.6 Diode End Cover Installation

1. Make sure all diodes are properly installed and securely tightened. Leads from diodes threaded into the end frame must be securely attached to the diode supports. The relay terminal lead must also be attached to the left diode support.
2. Connect leads from the three diodes mounted in supports to the output terminal stud. Tighten the attachment screw firmly. Place insulating bushing over relay terminal stud.
3. Place a new seal in the diode end frame.
4. With the end cover in place against the end frame, install the cap screws (7) and lock washers. Tighten the cap screws evenly and firmly.
5. Make sure the drain plug was installed in bottom of the end cover and was securely tightened.

## 6.7 Alternator Replacement

### 6.7.1 Removal

1. Place "Starter selector switch" in engine compartment to the "OFF" position.
2. Place the battery main disconnect switch to the "OFF" position.
3. Remove alternator driving belt (refer to appropriate heading later in this section).

**Note:** When reinstalling drive belt, it is important to set the belt tension correctly (refer to the appropriate heading later in this section).

4. Scratch off protective sealer from electrical connections (relay, field and positive terminals). Refer to figure 27.

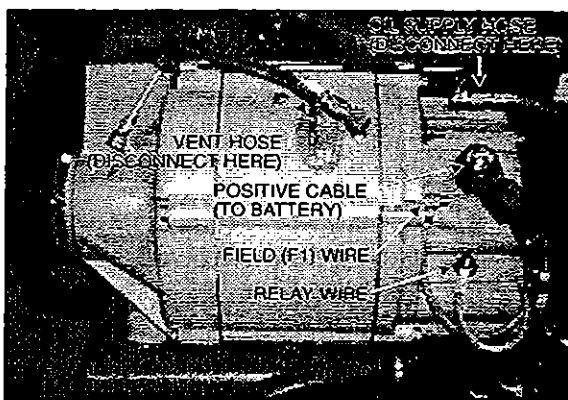

Figure 27

06073

**Note:** After reconnecting electrical wires, it is important to cover terminals with protective sealer (Prévost part no 68-0745).

5. Disconnect wire #25 from the relay terminal, wire #107 from the field "F1" terminal and disconnect battery cable from the positive "+" terminal on the diode end cover. Tag wires removed to ease identification at time of installation. Refer to figure 27.
6. Disconnect oil supply line and vent hose from top of alternator (refer to fig. 27) and tape lines to prevent entry of foreign matter. Disconnect oil drain hose from bottom of alternator (refer to fig. 28) and tape line to prevent entry of foreign matter.

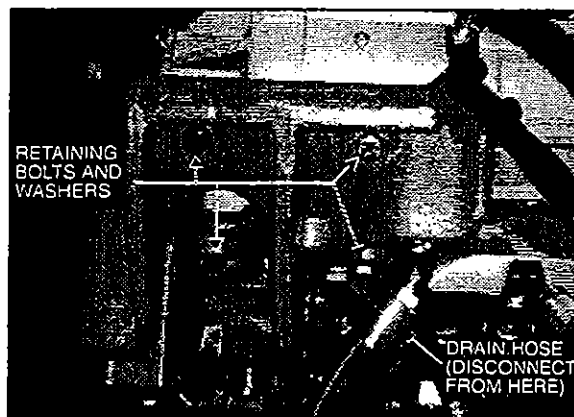

Figure 28

06074

7. Remove the four bolts and lock washer retaining alternator (refer to fig. 28).

**Warning:** Alternator weight is approximately 150 lbs (70 kg). Another person is required to take the alternator out of engine compartment.

8. Take the alternator out of engine compartment.

### 6.7.2 Disassembly of Alternator

After diode, field and stator winding checks, the alternator can be disassembled to repair a faulty component, such as field or stator, or to proceed with bearing or rotor replacement. The alternator may be disassembled by performing the following steps:

1. Remove nuts and washers from "DC" terminal on diode end frame.
2. Separate the diode cover plate from the diode end frame by removing the mounting screws.
3. Remove the washer, nut and lock washer attaching the diode supports to the end frame, the three screws connecting the diode leads to the diode supports, and the three nuts which attach the stator studs to the diode supports.
4. Separate the diode support assemblies from the diode end frame, and the three nuts which connect the studs to the diode end frame.
5. Mark the position of the drive end frame and diode frame with respect to the stator assembly so that the parts can be reassembled in the same position.
6. Detach the diode end frame and field assembly from the stator assembly by removing the attaching screws.

7. Separate the field assembly from the diode end frame by removing the four attaching screws.
8. Separate the rotor assembly and drive end frame from the stator assembly by removing the attaching screws.
9. Remove the shaft nut and washer and the pulley. Press the rotor shaft out of the drive end frame.
10. Remove the retainer plate and pull the bearings from the drive end frame.

### 6.7.3 Alternator Cleaning and Inspection

Whenever the alternator is disassembled, it should be cleaned and inspected.

#### Cleaning

If sludge has accumulated on the stator, a light mineral oil should be used to clean it.

#### Inspection

When the alternator has been disassembled to the extent that the stator is exposed, the stator should be checked for the following:

- a) Adequate varnish.
- b) Proper spacing of conductors so that "near shorts" do not exist.
- c) Proper phase lead placement.
- d) Strong conductor and cross-over welds.

### 6.7.4 Bearing or Rotor Replacement

Whenever the rotor and drive end frame are disassembled for any reason, the single-row ball bearing must be replaced with a new one due to the probability of damage during disassembly.

#### Removal and Disassembly

1. If the pulley was not removed from the rotor shaft at time of alternator removal, remove the nut and flat washer from the shaft and pull the pulley off the shaft.
2. Remove the six bolts and lock washers attaching the drive end frame to the stator frame. Separate the drive end frame from the stator frame. Remove the drive end frame and support assembly.
3. Support the drive end frame in an arbor press so that the rotor can be pressed down out of the end frame. Using a suitable adaptor against the end of the rotor shaft, which will pass through the inner race of the double-row ball bearing, press the rotor down out of the end frame and bearings. Since the single-row bearing outer race is held in the end frame by the retainer plate, and the inner race is press fit onto the rotor shaft, the bearing will probably be damaged when the shaft is pressed out and need to be replaced with a new part.
4. Remove the six screws attaching the bearing retainer plate to the drive end frame. Remove the retainer plate, the single-row bearing and the bearing spacer from the end frame.
5. Support the drive end frame in an arbor press with the double-row bearing down, so that the bearing can be pressed down out of the end frame. Using a suitable driver which will exert a force on the bearing outer race, press the bearing out of the end frame.
6. Remove the rubber bearing clamp from the groove in the end frame.

#### Assembly and Installation

1. Install a new single-row ball bearing into inner side of the drive end frame. Install the bearing retainer plate and attach with six screws. Stake screws in place after tightening.
2. Position the rubber bearing clamp in the groove in bearing bore of the drive end frame. Lubricate the clamp to permit the bearing to be pressed in without dislodging or damaging the clamp.
3. Position the rotor in an arbor press with the shaft end up. Install the drive end frame and single-row bearing assembly over the rotor shaft. Using a driver over the rotor shaft, which will exert a force on the bearing inner race, press the bearing onto the shaft until it bottoms against the rotor.
4. Install bearing spacer over the rotor shaft. Position the double-row bearing over the rotor shaft at end frame bore. Using an adaptor which will exert a force on both the inner and outer races of the bearing, press the bearing onto the shaft and into the end frame until the inner race bottoms against the bearing spacer.
5. Place a new seal around the drive end of the stator frame.
6. Insert the rotor between the stator and field, and position the drive end frame against the stator frame. Attach the end frame to the stator frame with six bolts and lock washers. Tighten the bolts to a torque of 5 to 5.4 ft•lbs (6-7 N•m).

**Caution:** When replacing the alternator on the vehicle, ensure that an alternator with the proper drive ratio is used. Installation of an alternator with any other drive ratio will result in severe and costly damage to the alternator and engine.

### 6.7.5 Reassembly

Reassembly is the reverse of disassembly.

**Note:** When tightening the outside nut on the "DC" output terminal, torque the nut to 30-35 lbf·ft (41-47 N·m). The lower nut should be supported while tightening the top nut.

When reinstalling diodes, tighten to a torque of 9-11 lbf·ft (12-15 N·m).

### 6.7.6 Output Check

When removed from the engine, the alternator may be checked without circulating oil on a test bench, providing the output is limited to 100 amperes or less. The alternator may be bench tested without circulating oil at outputs exceeding 100 amperes, as long as the period of operation is limited to less than 15 seconds.

**Caution:** Operating the alternator at outputs greater than 100 amperes without adequate oil circulation for periods exceeding 15 seconds, will cause the alternator to overheat, resulting in damage to the winding and diodes.

If the alternator is to be operated at an output greater than 100 amperes for longer than 15 seconds, circulating oil must be provided. SAE 30 engine oil must be applied to the connection on the diode end cover at a pressure of 35 psi and at a temperature of 60 °F to 220 °F (16 °C to 104 °C). This will provide an oil flow of about one gallon per minute.

To check the alternator on a test bench, make electrical connections as shown in figure 22. Make sure the negative battery terminal is connected to the alternator frame.

## 6.8 Alternator Drive Belt

### 6.8.1 Removal and Installation

#### Removal

1. Loosen the two bolts retaining the tensioning arm (refer to fig. 29).

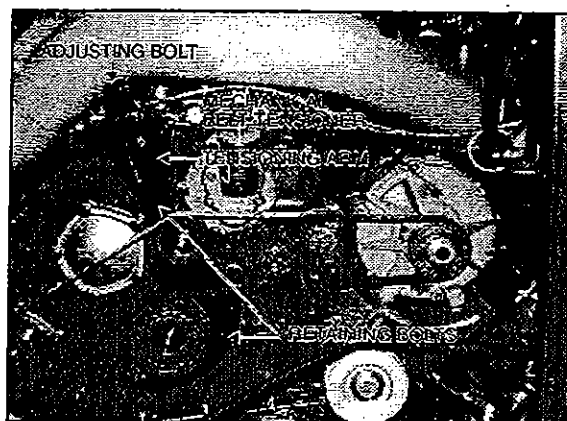

Figure 28

06075

2. Unscrew the adjusting bolt to slacken belt.
3. Remove belt.

#### Installation

Installation of the alternator drive belt is the reverse of removal.

**Note:** After belt installation, it is important to tension belt as per heading "6.8.2 Adjustment".

### 6.8.2 Adjustment

Correct belt tension is required to maximize belt life. The following procedure describes proper tensioning practices.

**Note:** Steps 1 and 2 should only be performed on new belts.

1. Loosen the two bolts retaining tensioning arm. Use the adjusting bolt to tension belt to 300 pounds.

**Note:** A belt tension gauge (Prévost kit no 01-1742) is available and is supplied with an instruction sheet. Refer to that procedure to use belt tension gauge correctly.

2. Run engine for 10 minutes and allow the belt to cool for 10-15 minutes.
3. Measure the belt tension. If tension on the belt is greater or equal to 200 pounds, no retensioning is required. If tension on the belt is less than 200 pounds, retension the belt to 200 pounds.



## 7. VOLTAGE REGULATOR

The 24 volt regulator is located on the back wall of the main electrical compartment. Refer to figure 5.

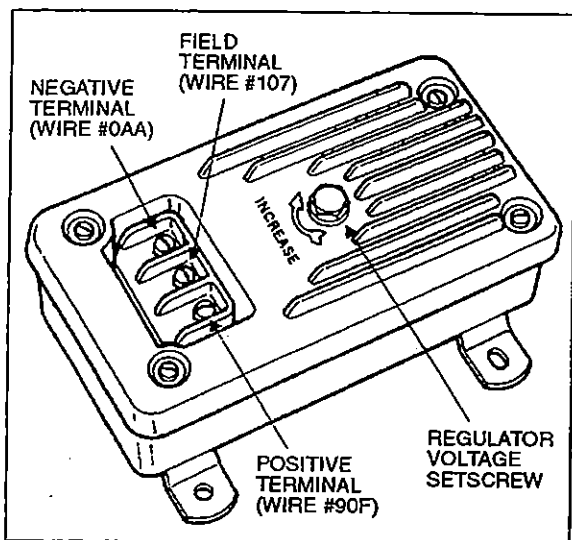

Figure 30

06076

### 7.1 Description

The transistor regulator illustrated in figure 30 is an assembly mainly consisting of diodes, capacitors, resistors and transistors. These components are mounted on a printed circuit panel board to form a completely static unit containing no moving parts. Regulators of this type have only three terminals which are identified "NEG" (ground), "FLD" (field) and "POS" (battery).

The regulator components work together to limit the alternator voltage to the preset value by controlling the alternator field current. This is the only function that the regulator performs in the charging system.

The voltage at which the alternator operates is determined by the regulator adjustment. Once adjusted, the alternator voltage remains constant. The regulator is unaffected by length of service, changes in temperature, or changes in alternator output and speed.

A typical wiring diagram of a negative ground system is illustrated in figure 31. This diagram shows only the basic charging system components. It does not show any components such as the control relays. Refer to "Charging system" wiring diagram, in "Wiring diagrams" for the electric circuits and connections.

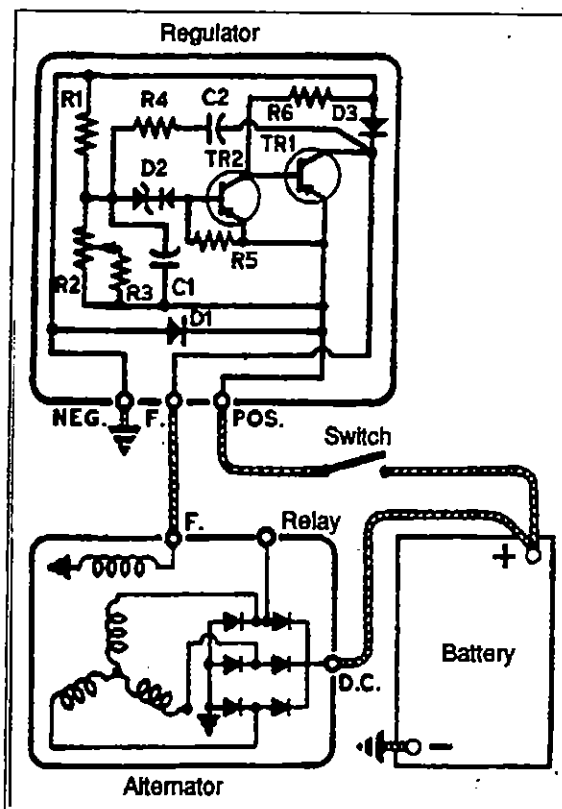

Figure 31

06077

### 7.2 Troubleshooting Procedures

Trouble in the electrical system will usually be indicated by one of two conditions: an undercharged or an overcharged battery. Either condition can result from an improper voltage regulator setting.

The absence of gassing during the continuous appearance of the green dot in the battery's built-in hydrometer indicates that the voltage setting is satisfactory.

## 7.3 Checking Regulator Voltage Setting

1. To check the voltage setting, connect a voltmeter across the "POS" and "NEG" terminals on the regulator, and an ammeter to the "DC" terminal on the alternator. Refer to figure 32.

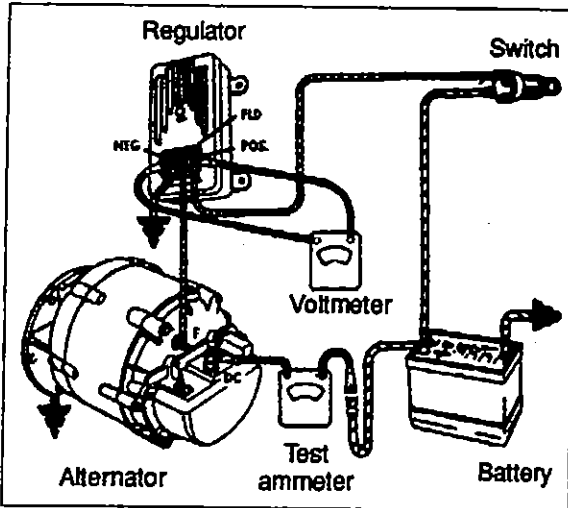

Figure 32

06078

2. Operate the engine at approximately 1000 rpm (about 2300 alternator rpm), with accessories on, to obtain an alternator output of 20-200 amperes.
3. Note the voltage setting. It should be steady at 27.5 volts.
4. If not, the desired setting can be obtained by removing the plug from the voltage regulator cover and slightly turning the adjusting screw inside the regulator. Turn the adjusting screw clockwise to increase the voltage setting or counterclockwise to decrease it. See figure 33 for details.

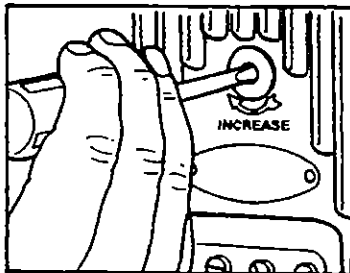

Figure 33

06079

**Note:** If regulator voltage cannot be adjusted to the specified setting, remove the regulator and repair or replace it as necessary.

### 7.3.1 Undercharged Battery

If the voltage setting is steady and reasonably close to the specified value and the battery is undercharged, raise the setting by 0.3 volts, then check for an improved battery condition over a minimum service period of 48 hours. If the voltage cannot be adjusted to the desired value, the alternator should be checked as follows:

1. Stop alternator, turn off all accessories and disconnect battery ground cable.
2. Disconnect all leads from the regulator and from the alternator field. Do not allow leads to touch ground.
3. Connect a voltmeter and an ammeter in the circuit at the alternator "DC" terminal.
4. Connect a jumper lead from the alternator "DC" terminal to the alternator field terminal.
5. Connect a carbon pile resistor load across the battery. Turn to the "OFF" position.
6. See figure 34 for wiring connections.

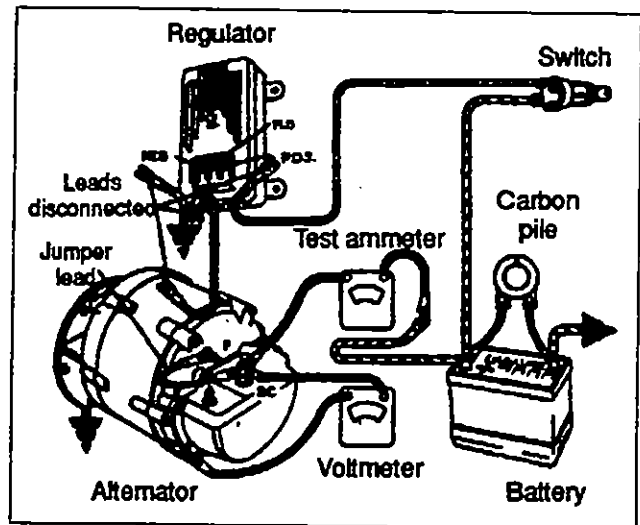

Figure 34

06080

7. Reconnect battery ground cable.
8. Turn on all vehicle accessories.
9. Operate alternator and adjust carbon pile resistor load as required to check for rated output as given in Delco-Remy Service Bulletin 1G-187 or 1G-188.
10. Check the alternator field winding as follows:

Disconnect the lead from the field terminal and connect an ohmmeter from the field terminal to

ground. A resistance reading above normal indicates an open field, and a resistance reading less than normal indicates a shorted or grounded field. The normal resistance can be calculated by dividing the voltage by the field current published in Delco-Remy Service Bulletin 1G-186, 1G-187, or 1G-188. The normal resistance value should be at or near mid-scale on the ohmmeter for accuracy. An alternate method of checking is to connect a battery of specified voltage and an ammeter in series with the field winding, and compare readings with published specifications in Delco-Remy Service Bulletin 1G-186, 1G-187, or 1G-188. An alternator is defective if it does not produce rated output or if field windings are faulty. If the alternator provides rated output, and field windings check satisfactorily, the regulator should be checked as covered under heading "*Regulator checks*".

### 7.3.2 Overcharged Battery

If the voltage setting as checked above is steady and reasonably close to the specified value, lower the setting by 0.3 volt and check for an improved battery condition over a minimum service period of 48 hours. If the voltage cannot be adjusted to the desired value, proceed as follows: where the alternator field is grounded internally in the alternator as shown in figure 31, a shorted or grounded field or a defective regulator can cause an overcharged battery. The field winding can be checked as covered in the "*Undercharged battery*" section. If the field winding is found to be correct, the alternator is not defective, and the regulator should be checked as covered under heading "*Regulator checks*".

## 7.4 Regulator Checks

Separate the cover from the base, and remove the panel assembly from the cover. Carefully note the location of all washers and lock washers.

The component parts are keyed to figure 31. Before making electrical checks, visually inspect the components and make sure all soldered connections are secure. Various electrical checks with an ohmmeter can be made to determine which components are defective.

The ohmmeter must be accurate, and should be a scale-type meter with a 1.5 or 3 volt cell. Most digital ohmmeters cannot be used to check semiconductors. However, some digital ohmmeters are specially designed to test semiconductors and can be used to test components in the regulator. Consult the ohm-

meter's manufacturer for specifications concerning the capabilities of the ohmmeter.

It is important that all of the following checks be made. If a defective part is found, replace it before proceeding with the remaining checks. Be sure to make all the checks since more than one component may be defective.

A defective regulator can be repaired according to the following methods:

- A) By changing the printed circuit board in the regulator. Unscrew the retaining screws on the printed circuit board and remove it. Install a new printed circuit board. This method is the most commonly used.
- B) By removing any retaining screws involved and unsoldering the connections. When resoldering, limit solder time to a minimum as excessive heat may damage the printed circuit board and component parts. However, good soldered connections are essential for satisfactory operation. A resin core 63% tin 37% lead solder with a 360 °F (182 °C) melting point is recommended along with a soldering iron rated at 50 watts or less. Use extreme care to avoid overheating. Before checking the printed circuit board, remove transistor TR1, which must be checked separately. Connect the ohmmeter as shown in figure 35, and then reverse the ohmmeter leads to obtain two readings on the same component. Use the middle scale on scale-type meters on which the 300 ohm value should be within, or nearly within, the middle third of scale.

**Capacitors C1 and C2** = The ohmmeter should read high and low on each capacitor. If not, replace capacitor.

**Diodes D1, D2, and D3** = Each diode should give one high and one low reading. If not, replace diode.

**Resistor R2** = Turn voltage adjustment screw (identified in figure 33) with ohmmeter connecting each way. Reading should change as slotted screw is turned. If not, replace R2.

**Transistor TR1** = See figure 35. Use the low scale. Each of the three checks should read low and high. If not, replace TR1.

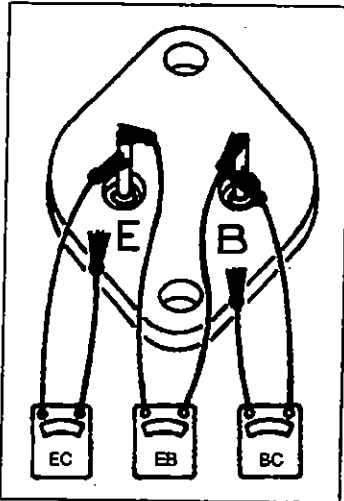

Figure 35 06081

Transistor TR2 = Change the ohmmeter to use the low scale. EB should read low and high. BC should read low and high. EC should both read high. If not, replace TR2. See figure 36.

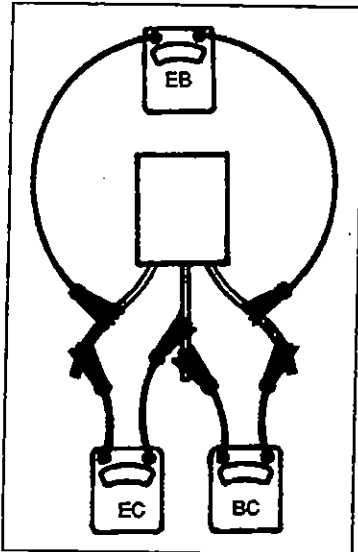

Figure 36 06082

## 7.5 Adjusting Voltage

After repair, the regulator must be adjusted to the desired voltage setting. Follow the procedure under "Checking Voltage Setting". Slowly turn the adjusting screw full range and observe the voltmeter to ensure that the voltage is being controlled, then, still turning, slowly adjust to the desired setting.

## 8. BATTERY EQUALIZER

### 8.1 Description

The battery equalizer is an energy transfer device. It allows 12 and 24 volt power to be taken simultaneously from a 24 volt battery system. The equalizer is designed to be connected to the batteries continuously, similar to an alternator. The amount of continuous 12 volt current is limited to the capacity (number of amps) of the equalizer. The equalizer causes the 12 volt current to be taken from both banks of batteries. For example, if a 10 amp, 12 volt load is presented to the system, 5 amps would be supplied by each bank of batteries. Any imbalance between the batteries is automatically equalized.

### 8.2 Operation

#### 8.2.1 Situation 1

24 and 12 volt loads present - alternator on:

The alternator provides 24 volt service, the equalizers provide 12 volt service from both banks of batteries.

#### 8.2.2 Situation 2

24 and 12 volt loads present - alternator off:

Both banks of batteries discharge at an equal rate, even though there is an unequal load.

#### 8.2.3 Situation 3

24 volt only - alternator on or off:

The equalizers are in the standby mode.

#### 8.2.4 Situation 4

12 volt load only - alternator off:

The equalizers provide 12 volt current from both banks of batteries.

## 8.3 Advantages

### 1. Eliminates overcharging

The battery equalizer is designed to eliminate the overcharging of one bank of batteries in a split 24/12 volt system. This device electronically monitors voltages of both battery banks, and transfers current whenever one bank of batteries discharges at a rate different from the other.

### 2. Extends normal battery life

By maintaining equalization down to 0.1 volt, the equalizer will extend normal battery life by preventing both overcharging and undercharging.

## 9. STARTING MOTOR

### 9.1 Description

The starting motor has a shift lever and solenoid plunger that are totally enclosed to protect them from exposure to dirt, icy conditions and splashing.

Positive lubrication is provided to the bronze bushing located in the commutator end frame, in the lever housing and in the nose housing, by an oil-saturated wick that projects through each bushing and contacts the armature shaft.

The clutch is a "Positorc" drive type, that meshes with the ring gear by the action of the solenoid. Once engaged, the clutch will not disengage during intermittent engine firing, which prevents damage to pinion and ring gear teeth. The pinion remains engaged until starting is assured and the solenoid circuit is interrupted. Refer to figure 37 for more details.

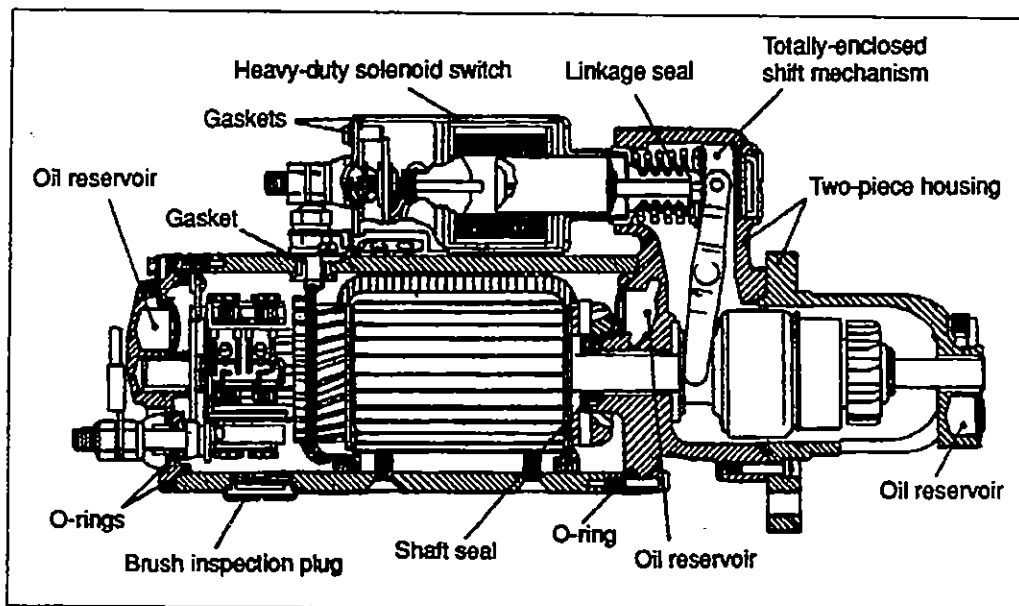

Figure 37

06083

### 9.2 Maintenance

All wicks and oil reservoirs should be saturated with SAE 10 oil, and the splines underneath the clutch should be lubricated with a light coating of SAE 10 oil. Other than normal periodic lubrication and

keeping cable connections clean and tight, the starting motor should require no periodic maintenance. However, under normal operating conditions, the starting motor should be disassembled, inspected, cleaned and tested at time of engine overhaul.

## 9.3 Troubleshooting

Failure of the cranking motor to crank the engine at normal cranking speed may be due to a defective battery, worn battery cables, poor connections in the cranking circuit, defective engine starting switch, low temperature, condition of the engine or a defective cranking motor. To determine if the cranking motor is the problem, it will first be necessary to check the batteries, the cranking circuit, the magnetic switch, the solenoid and the control switch.

To obtain full performance data on a starting motor, or to determine the cause of abnormal operation, the starting motor should be subjected to the following tests. These tests are performed with the starting motor removed from the engine. Check the armature for freedom of rotation by prying on the pinion with a screwdriver. Tight bearings, a bent armature shaft, or a loose pole shoe screw will prevent the armature from turning freely. Failure of the starting motor to perform according to specifications will require disassembly of the motor for further checks and adjustments. However, if the armature does rotate freely, the motor should be given a no-load test before disassembly.

**Caution:** Never operate the starting motor more than 30 seconds at a time without pausing to allow it to cool for at least 2 minutes. Overheating, caused by excessive starting, will seriously damage the starting motor.

### 9.3.1 No-Load Test

Before disassembly of the starting motor, the following check of starting motor operation should be done to determine any condition which may require special attention during overhaul. Make test connections to the starting motor as in figure 38.

Connect the starting motor in series with fully charged batteries to give 24 volts, an ammeter capable of reading several hundred amperes, and a variable resistance. Also connect a voltmeter as illustrated in figure 38 from the solenoid motor (M) terminal to the starter frame. An rpm indicator is necessary to measure armature speed. Proper voltage can be obtained by varying the resistance unit.

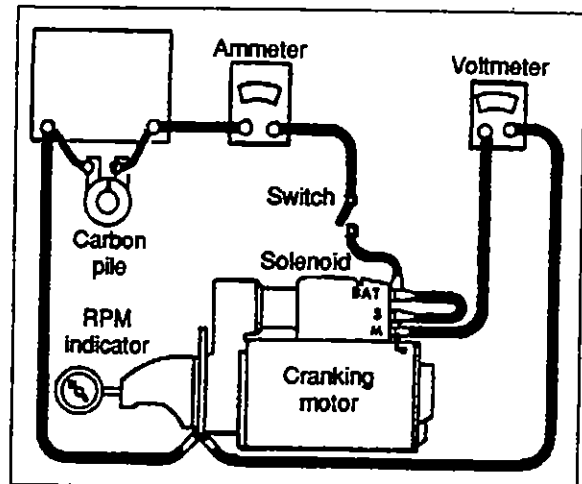

Figure 38

06084

#### No-load test results

1. Rated current draw and no-load speed indicate normal condition of the starting motor.
2. Low free-speed and high current draw indicate the following:
  - a) Excessive friction. Tight, dirty, or worn bearings, bent armature shaft, or loose pole shoes allowing the armature to drag.
  - b) Shorted armature. This can be further checked on a growler after disassembly of the starting motor.
  - c) Grounded armature or fields. Check again after disassembly.
3. Failure of the starting motor to operate with high current draw indicates the following:
  - a) A direct ground in the terminal or fields.
  - b) "Frozen" bearings. This should have been determined by turning the armature by hand.
4. Failure to operate with no current draw indicates:
  - a) Open field circuit. This can be checked after starting motor disassembly by inspecting internal connections and tracing circuit with a test lamp.
  - b) Open armature coils. Inspect the commutator for badly burned bars after disassembly.
  - c) Broken brush springs, worn brushes, high insulation between the commutator bars or other causes which would prevent good contact between the brushes and commutator.

5. Low no-load speed and low current draw indicate high internal resistance due to poor connections, defective leads, dirty commutator and causes listed previously in step 4.
6. High free-speed and high current draw indicate shorted fields. If shorted fields are suspected, replace the field coil assembly and check for improved performance.

### 9.3.2 Lock-Torque Test

A variable resistance with a high current capacity should be used. The starting motor should be securely mounted and a brake arm hooked to the drive pinion. When specified current is applied, the torque can be computed from the reading on the scale. A one foot brake arm will directly indicate foot-pounds.

**Warning:** This test requires extreme caution. Follow instructions carefully.

## 9.4 Disassembly and Reassembly

### 9.4.1 Disassembly

Normally, the starting motor should be disassembled only far enough to make repairs or to replace the defective parts. As a precaution, it is suggested that safety glasses be worn when disassembling or assembling the cranking motor. Proceed as follows:

1. Note the relative position of the solenoid, lever housing, and nose housing so the motor can be reassembled in the same manner.
2. Disconnect field coil from the solenoid motor terminal, and lead from the solenoid ground terminal.
3. On motors with brush inspection plugs, remove the plugs and then remove the brush lead screws. This will disconnect the field leads from the brush holders.
4. Remove the attaching bolts and separate the commutator end frame from the field frame.
5. Separate the nose housing and field frame from the lever housing by removing attaching bolts.
6. Remove armature and clutch assembly from lever housing.
7. Separate solenoid from the lever housing by pulling apart.

### 9.4.2 Cleaning

The driving mechanism armature and fields should not be cleaned in a degreasing tank, or with grease dissolving solvents, since these would dissolve the lubricants in the drive mechanism and damage the insulation in the armature and field coils. All parts, except the drive, should be cleaned with mineral spirits and a brush. The drive can be wiped with a clean cloth.

If the commutator is dirty, it may be cleaned with No. 00 sandpaper.

**Caution:** Never use emery cloth to clean commutator.

### 9.4.3 Armature Servicing

If the armature commutator is worn, dirty, out of round, or has high insulation, the armature should be put in a lathe so the commutator can be turned down. The insulation should then be cut 1/32" (0,79 mm) wide and 1/32" (0,79 mm) deep, and the slots cleaned out to remove any trace of dirt or copper dust. As a final step in this procedure, the commutators should be sanded lightly with No. 00 sandpaper to remove any burrs left as a result of the undercutting procedures.

The armature should be checked for opens, short circuits and grounds as follows:

#### Open Circuit Test

Open circuits are usually caused by excessively long starting periods. The most likely place for an open circuit to occur is at the commutator riser bars. Inspect the points where the conductors are joined to the commutator bars for loose connections. The poor connections cause arcing and burning of the commutator bars as the starting motor is used. If the bars are not too badly burned, repair can often be performed by resoldering the leads in the riser bars (using rosin flux), and turning down the commutator in a lathe to remove the burned material. The insulation should then be undercut.

**Caution:** Do not undercut the insulation between the commutator segments after turning down the commutator.

#### Short Circuit Test

Short circuits in the armature are located by means of a growler. When the armature is revolved in the growler with a steel strip such as a hacksaw blade held above it, the blade will vibrate above the area of the armature core in which the short circuit is lo-

## Section 6: ELECTRICAL SYSTEM

cated. Short circuits between bars are sometimes produced by brush dust or copper between the bars. These short circuits can be eliminated by cleaning out the slots.

### Ground Test

Grounds in the armature can be detected by the use of a 110 volt test lamp and test points. If the lamp lights when one test point is placed on the commutator with the other point on the core or shaft, the armature is grounded. Grounds occur as a result of insulation failure, which is often brought about by overheating of the starting motor produced by excessively long starting periods, or by accumulation of brush dust between the commutator bars and the steel commutator ring.

### 9.4.4 Field Coil Checks

The field coils may be checked for grounds and opens by using a test lamp.

#### Grounds

If the motor has one or more coils normally connected to ground, the ground connections must be disconnected during this check. Connect one lead of the 110 volt test lamp to the field frame and the other lead to the field connector. If the lamp lights, at least one field coil is grounded, and it must be repaired or replaced.

#### Opens

Connect test lamp leads to ends of field coils. If lamp does not light, the field coils are open.

### 9.4.5 Field Coil Removal

Field coils can be removed from the field frame assembly by using a pole shoe screwdriver. A pole shoe spreader should also be used to prevent distortion of the field frame. Careful installation of the field coils is necessary to prevent shorting or grounding of the field coils as the pole shoe is tightened into place. Where the pole shoe has a long lip on one side and a short lip on the other, the long lip should be assembled in the direction of armature rotation so it becomes the trailing (not leading) edge of the pole shoe.

### 9.4.6 Reassembly

Reassembly is the reverse of disassembly.

To reassemble the end frame with brushes onto the field frame, pull the armature out of the field frame

just far enough to permit the brushes to be placed over the commutator. Then push the commutator end frame and the armature back against the field frame.

The recommended torque for the cross-slotted pole shoe screws is 25-35 ft•lbs (34-47 N•m).

## 9.5 Pinion Clearance

Pinion clearance should be checked after reassembly of motor to ensure the clearance is within specifications. To check pinion clearance (starting motor off engine), first disconnect the motor field connector from the solenoid motor terminal. Connect 24 volt battery with the positive battery lead to the solenoid switch terminal (5), and the negative battery lead to the grounded (G) solenoid terminal. Momentarily flash a jumper lead from the solenoid motor terminal to the grounded (G) solenoid terminal. The pinion gear will now shift into cranking position and remain that way until the battery is disconnected. Push the pinion or drive back towards the commutator end to eliminate slack movement. Measure the distance between pinion and pinion stop. This should be  $23/64" \pm 1/32"$  (9,5 mm  $\pm$  0,79 mm). Pinion clearance is adjusted to these limits by turning the solenoid shaft nut after removing access plug in shift housing. See figure 39.

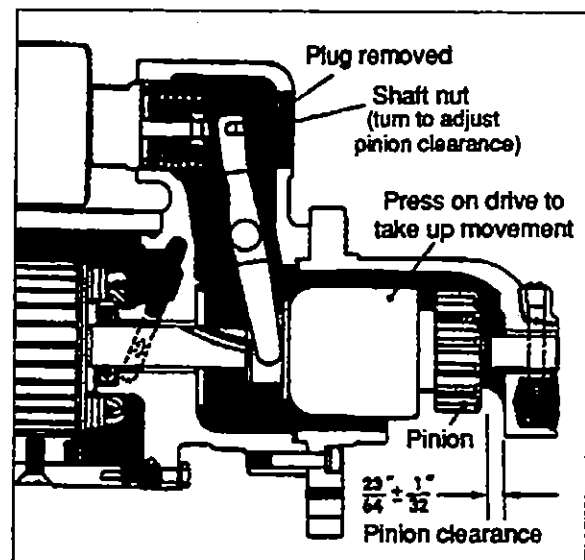

Figure 39

06085



## 9.6 Starter Solenoid

### 9.6.1 Description

The starting motor solenoid allows the starting motor pinion to mesh with the flywheel ring gear and also closes the electric circuit to energize the starting motor.

There are two windings in the solenoid: a pull-in winding and a hold-in winding. Both windings are energized when the external control switch is closed. They produce a magnetic field which pulls the plunger in so that the drive pinion is allowed into mesh, and the main contacts in the solenoid switch are closed to connect the battery directly to the starting motor. Closing of the main switch contacts shorts out the pull-in winding since this winding is connected across the main contacts. The magnetism produced by the hold-in winding is sufficient to hold the plunger in, and shorting out the pull-in winding reduces drain on the battery. When the control switch is opened momentarily, the pull-in winding and the hold-in winding are connected in series between the battery and common ground.

The polarity of the pull-in winding is reversed and opposes the magnetic pull of the hold-in winding. All magnetic holding force on the solenoid plunger is thus cancelled. The return spring then quickly pulls the solenoid plunger back, opening the solenoid switch contacts and withdrawing the pinion gear from the meshing position at the same time. Proper operation of the switch depends on maintaining a definite balance between the magnetic strength of the pull-in and hold-in windings.

This balance is established in the design by the size of wire and the number of turns specified. An open circuit in the hold-in winding or attempts to start the motor with a discharged battery may cause the switch to chatter.

### 9.6.2 Disassembly

To disassemble the solenoid, remove nuts, washers, and insulators from the switch terminal and battery terminal. Unscrew cover screws and remove cover. Take out the contact disk assembly.

### 9.6.3 Solenoid Maintenance

The solenoid requires no periodic maintenance other than keeping the terminals clean and tight. Always check action of the solenoid if it has been removed. If the unit fails to function, first check wiring before

condemning the solenoid. Solenoid windings can be checked for open or short circuit or current draw.

### 9.6.4 Solenoid Tests

Two tests must be done to determine the current draw of (1) both windings in parallel and (2) the hold-in winding alone. The solenoid windings can be tested with the solenoid either off or on the starting motor. However, when the solenoid is checked on the starting motor, it is necessary to disconnect both leads at the main solenoid terminals to prevent interference. The main solenoid terminal which is normally connected to the starting motor must then be grounded to the solenoid base by means of a jumper lead. For the first test, connect a source of variable voltage (battery and a variable resistance) in series with an ammeter between the solenoid base and the solenoid small switch terminal. Connect a voltmeter between the same two points. Slowly increase voltage and note the current draw. This should be 55-63 amps at 24 volts. Disconnect the jumper lead grounding the main solenoid terminal, and readjust the variable resistance to obtain the specified voltage of 24 volts. This should not exceed 6.8 amperes.

When the solenoid has been removed from the starting motor for repair or replacement, the linkage must be adjusted to provide the correct pinion clearance when the solenoid is remounted on the starting motor. See "*Starting motor*" earlier in this section for correct pinion clearance adjustment.

### 9.6.5 Recommendations

1. Tag each lead to ensure correct connections when the starting motor is reinstalled.
2. Tighten the 5/8"-11 starter attaching bolts to a torque of 137-147 lbf•ft (186-200 N•m).
3. Keep all the electrical connections clean and tight.
4. When installing wiring terminal leads to the starting motor and the solenoid switch, torque the No. 10-32 connections to 16-30 lbf•in (2-3 N•m) and the 1/2"-13 connections to 20-25 lbf•ft (27-34 N•m).

## 10. ENGINE BLOCK HEATER

An engine "immersion-type" block heater is installed as standard equipment. It consists of a 115 volt, 1500 watt, single loop element type, fitted at center of engine block (radiator side). It is plugged into a socket on the engine compartment rear door.

### 10.1 Maintenance

This heater is non-serviceable except for the cord, and if faulty, must be replaced as a unit.

## 11. EXTERIOR LIGHTING EQUIPMENT

The circuit for exterior lights, as well as their control switches, relays and circuit breakers are shown on the applicable wiring diagrams (pages 5 to 7), annexed at the end of this section.

### 11.1 Headlights

Each headlight assembly consists of two 12 volt halogen rectangular sealed-beam units. Outer lamps are double-filament units, having high and low beams. Inner lamps have single-filament and operate with high beam of outer units. For identification purposes, outer units are molded with "2A1" and inner units are molded with "1A1" on top of the lens.

#### 11.1.1 Headlight Dimmer Switch

The multifunction lever located on the steering column is used to select proper lighting. High beams or low beams can be selected by pushing the lever towards the dashboard (high) or pulling it towards the driver (low). A high beam indicator on the central dashboard panel is illuminated when the high beam circuit is energized.

**Note:** High beams can be flashed momentarily by pulling the lever completely towards the driver and then releasing it.

#### 11.1.2 Maintenance

Clean headlights with soap and water and a good glass cleaner whenever dirty. For maximum illumination, headlight connections must be coated with a dielectric grease to prevent oxidation and proper voltage must be maintained. Low battery voltage,

loose or dirty contacts in wiring system and poor ground contribute to a decrease in voltage. Check wiring and connections regularly and keep battery properly charged. When a headlight burns out, a new sealed-beam unit must be installed.

Headlights must be properly aimed to provide maximum allowable road illumination. When using mechanical aimers, follow manufacturer's instructions.

Headlight aim should be checked after installing a new sealed-beam unit. Aiming can be performed without removing headlight bezels. Horizontal and vertical aiming of each sealed-beam unit is provided by two adjusting screws which move the mounting ring in the body against the tension of the coil spring (see figure 40). There is no adjustment for focus since the sealed-beam unit is set for proper focus during manufacturing assembly.

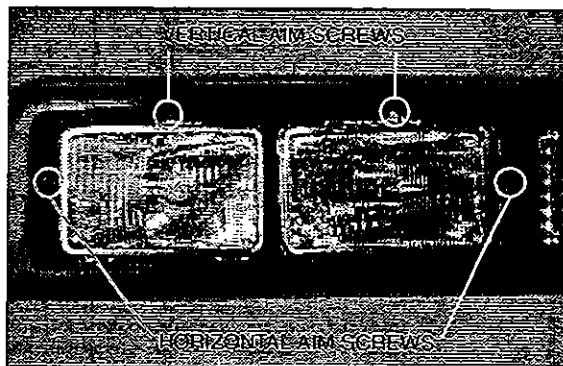

Figure 40

06086

#### 11.1.3 Headlight Adjustment

The following is a general procedure for headlight adjustment using a mechanical equipment, such as a "Bear 47-132 headlight aligner". If your mechanical equipment is different, refer to the manufacturer's instruction manual.

##### Setting Aligner According to Slope

The floor level offset dial must match with slope to ensure a precise alignment.

1. Park vehicle on a level floor.
2. Fix one (1) calibration fixture to each aligner.
3. Install aligner in center of each wheel on one side of vehicle. Unit B must be installed beside the front axle wheel with its viewing port facing rearward, and unit A beside the drive axle wheel with its viewing port facing forward. See figure 41 for more details.

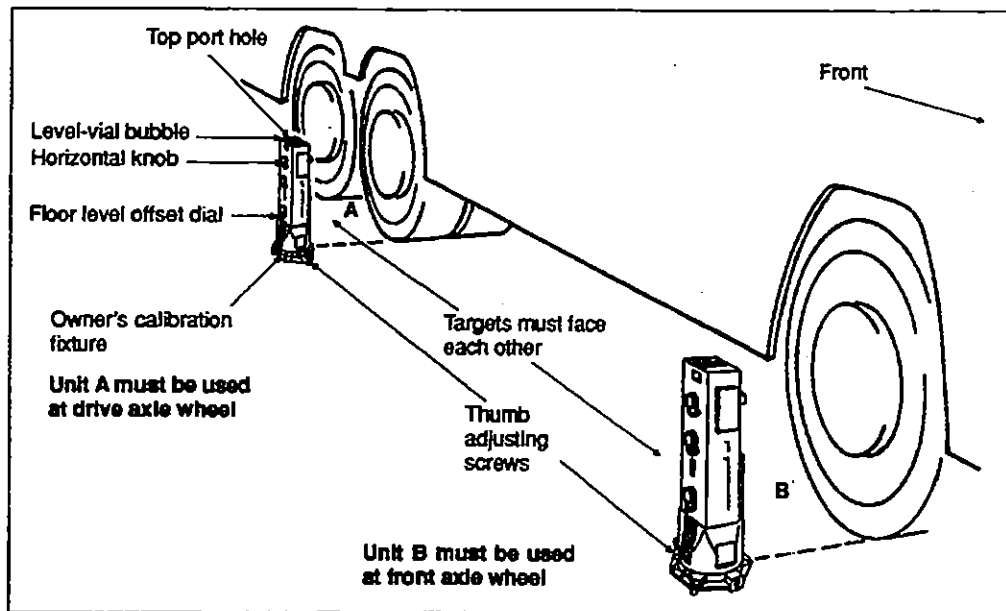

Figure 41

06087

**Note:** Check that the three indicators on each module are set to zero.

4. Level each unit with the thumb adjusting screw on the fixture until level-vial bubble is centered.
5. Look through the top port hole of unit A, and turn horizontal knob until split images are aligned. See figure 42.

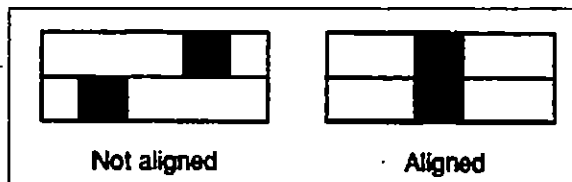

Figure 42

06088

6. Set according to floor slope. Transfer positive (+) or negative (-) reading of horizontal dial to the floor level offset dial to offset floor slope on each aligner (see fig. 43). Push on the floor level offset dial to register reading.
7. Remove calibration fixture from each unit.

**Note:** If vehicle remains stationary during the headlight alignment procedure, avoid checking floor slope each time.

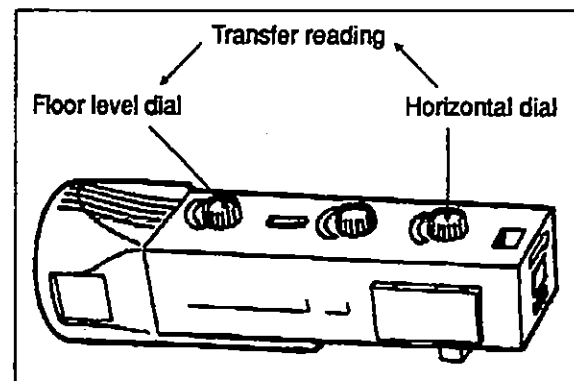

Figure 43

06089

### Headlight alignment

The aligner is provided with adaptors for different sizes of headlights which are always aligned in pairs.

1. Fix the adequate adaptor on each headlight.

**Note:** The adaptors are equipped with steel inserts, thus providing a good seating for precise headlight adjustment.

2. Install aligners on headlights (unit A on driver's side and unit B on other side with the sight openings facing each other) by pushing the handle forward to secure rubber suction disc. Pull handle until it locks. Refer to figure 44.

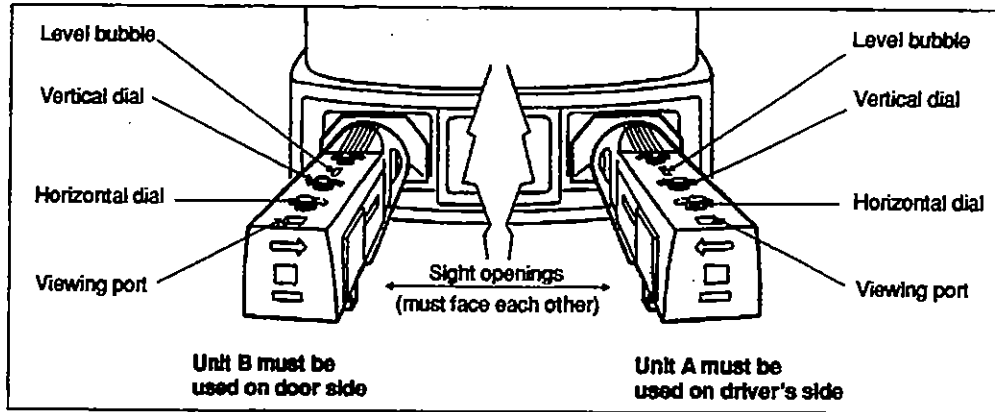

Figure 44

06090

**Note:** Ensure that floor level offset dial is set correctly before aligning headlights.

**Horizontal alignment**

1. Reset horizontal dial to zero.
2. Check that split image is visible in the viewing port. If not, replace aligner by turning it.
3. Turn the horizontal aim adjusting screw of each headlight until split image is aligned (see fig. 45).

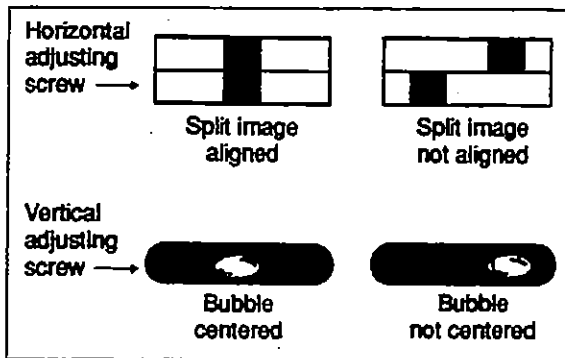

Figure 45

06091

**Vertical alignment**

1. Reset vertical dial to zero.
2. Turn the adjusting screw of the headlight vertical aim until bubble is centered (see fig. 45). Repeat operation on other headlight.
3. Recheck the horizontal alignment.

Remove aligners by pressing on vacuum release button.

Repeat the same procedure for the high beams.

If proper mechanical equipment is not available, perform adjustments as described below:

1. Park vehicle on level floor so headlights are 25 feet (7,6 m) from a smooth surface preferably of light color. A door or wall is suitable. Center line of vehicle should be perpendicular to this vertical surface.
2. Draw a horizontal line on vertical surface at height of light center. Locate point on this horizontal line at which projected centerline of vehicle intersects. Measure distance between light centers and divide this distance equally on either side of center mark. Then draw two vertical lines directly ahead of each light center.
3. Switch on high beams and cover one headlight while adjusting the other.
4. When aiming headlights, beam may appear distorted. A new sealed-beam unit must be installed to correct this condition.
5. After headlight is properly aligned, cover it and proceed in the same manner as above with the opposite headlight.

## 11.2 Sealed-Beam Unit Replacement

### 11.2.1 Removal

1. Remove screws attaching headlight bezel to front panel (12 "Phillips" screws) and remove bezel.
2. Remove four mounting screws attaching sealed-beam unit retaining ring to mounting ring.

**Note:** Do not disrupt headlight screw adjustment.

3. Remove sealed-beam unit and pull wiring connector off back of unit.

### 11.2.2 Replacement

1. Install wiring connector on back of sealed-beam unit. Position unit in mounting ring with molded lens number at top.

**Note:** Sealed-beam units with number "1A1" molded, on top of the lens must be used at inside light positions. Units with number "2A1" molded, on top of the lens must be used at outside light positions.

2. Position the retaining ring over the lens and secure it to the mounting ring with four screws.

**Note:** The headlight aim must be checked and adjusted even if it was properly adjusted before the sealed-beam unit was replaced, and adjusting screws were not removed.

3. After installing and adjusting the headlight assembly, install the headlight bezel.

## 11.3 Front Turn Signal

The front turn signal is a part of the front headlight cluster. The turn signal lens is located on each front corner and shares a common bezel with the headlights. Turn signal is visible from both front and side.

### 11.3.1 Bulb Removal and Replacement

1. Remove the twelve "Phillips" screws attaching the headlight bezel, then remove headlight bezel.
2. Remove socket from headlight bezel.
3. Remove the bulb by pushing and rotating it out of the socket.
4. Install the new bulb by reversing the previous procedure.

## 11.4 Stop, Tail, Directional, Back-up, and Hazard Warning Lights

A combination stoplight, taillight, directional signal light and back-up light assembly is mounted at the rear, on each side of the vehicle. Furthermore, when braking, a center stoplight will illuminate simultane-

ously with the stoplights on the sides for increased safety.

The stop, tail, directional signal and back-up lights consist of individual bulbs mounted in a common housing, and each light is serviced individually as a complete unit and need only to be plugged into or unplugged from socket after removing proper light lens.

The hazard warning flashing system uses the front, side, and rear directional lights simultaneously. This system is energized by a switch on the L.H. dashboard.

### 11.4.1 Bulb Removal and Replacement

1. Unscrew the retaining lens screws (2), then remove the lens.
2. Remove the bulb by pushing and then rotating it counterclockwise out of the socket.
3. Install the new bulb by pushing and rotating it clockwise, then replace the lens; the "Hella" inscription molded on the lens must be pointing upwards.

**Note:** Taillights are provided with a different candle power bulb. Make sure appropriate replacements are used for any defective bulbs.

## 11.5 License Plate Light

Two sealed units are mounted above the rear license plate(s) of vehicle. In case of burn out, the sealed unit must be changed according to the following procedure.

1. Pry out the rubber seal with a small screwdriver. Pull on the sealed unit and disconnect it.
2. Reconnect new sealed unit, place rubber seal, and press on it until it is seated in its former position.

## 11.6 Clearance, Identification and Marker Lights

This vehicle is equipped with marker, identification and clearance lights. The clearance lights are mounted at each corner of the coach near the top and the identification lights are in the upper center of rear and front sections. The rear clearance lights are red and the front ones are yellow.

The yellow marker lights are mounted on the sides of vehicle.

### 11.6.1 Marker Light Bulb Removal and Replacement

The side marker light is a sealed unit and should be replaced as an assembly in accordance with the following procedure:

1. Unscrew both "Phillips" light screws, then remove the light assembly.
2. Pull the connector to remove it from its socket.
3. Push the connector on the new light unit.
4. Position light assembly and install the "Phillips" screws.

### 11.6.2 Clearance and Identification Light Bulb Removal and Replacement

The clearance and identification light bulb can be replaced in accordance with the following procedure:

1. Unscrew both "Phillips" lens screws, then remove the lens and housing.
2. Twist the bulb socket and pull out.
3. Pull the bulb straight out to remove it from its socket. Do not try to turn the bulb to remove it.
4. Install the new bulb by pushing it into the socket.
5. Position lens on housing, then install the "Phillips" screws.

## 11.7 Docking and Cornering Lights

This vehicle is provided with two halogen headlights that serve as cornering lights. They are mounted on the vehicle as follows: one is mounted on the front L.H. side service compartment door, while the other is located between the front wheel and the entrance door on the R.H. side. The main function of these lights is to increase lateral visibility when turning a corner. These lights are energized simultaneously with the directional lights. On the V.I.P. model, a dashboard-mounted rocker switch may be actuated to cancel this system in special situations.

Two additional halogen headlights are installed on rear electrical compartment doors. These lights are used as docking lights and both will illuminate automatically when reverse range is selected to facilitate back-up or docking procedure.

On the V.I.P. model, these lights do not operate automatically when the reverse range is selected,

but by means of a dashboard-mounted rocker switch. When actuated, the docking as well as the cornering lights illuminate. Furthermore, a "Low docking" switch, also located on dashboard, allows the use of the docking and cornering lights at a lower intensity when the docking switch is actuated.

### 11.7.1 Bulb Removal and Replacement

Both docking and cornering headlights can be changed in accordance with the following procedure:

1. Remove the two "Phillips" screws attaching the retaining ring.
2. Disconnect the light unit connection.
3. Press on each tab of retaining clip, bring both tabs together, then lift the retaining clip.
4. Remove the bulb.
5. Position new bulb, install the retaining clip, then bring both tabs together. When the retaining clip is in position, release the tabs.

**Caution:** During this step, avoid contacting the bulb with your fingers. This could alter the bulb life.

6. Connect and position the light unit.
7. Finally, install the retaining ring.

## 11.8 Fog Lights

Optional halogen fog lights can be mounted on this vehicle to give the driver better visibility in foggy weather, or to improve the range of vision just ahead of the coach.

### 11.8.1 Bulb Removal and Replacement

1. Remove the protector cap on light unit (if so equipped). Remove the light unit retainer screw and slide the retainer upward.
2. Remove the light unit. Disconnect the light unit connection.
3. Remove retaining clip from its notches, then lift the retaining clip and remove the bulb.
4. Install the new bulb, then replace the retaining tab of clip to its position into the notches.

**Caution:** During this step, avoid contacting the bulb with your fingers. This could alter the bulb life.

5. Reconnect the light unit and replace in its proper position.
6. Replace the retainer.
7. Replace the light unit cover (if so equipped).

## 12. INTERIOR LIGHTING EQUIPMENT

### 12.1 Control Panel Lighting

The instrument gauges and switches mounted on all control panels are energized whenever the exterior light switch is pushed to the first position. A control dimmer at the extremity of the L.H. side control panel is used to vary the brightness of the panel gauges, switches and indicator lights.

The gauge lights, panel lights, switch lights and indicator lights have a different bulb arrangement. Thus, the procedure to change a defective bulb can vary according to the application.

#### 12.1.1 Switch Bulb Replacement

1. Slightly pull the switch with a defective bulb away from the control panel.
2. Using a small screwdriver, press the tab on top of the switch housing. Pull the switch away from the control panel.
3. Using the same screwdriver, press on the light bulb housing tab in order to remove it from the switch.
4. The light bulb may be removed by pulling it away.
5. Install the new bulb by pushing it into the socket.
6. Install the light socket in its former position.
7. Replace the switch on control panel.

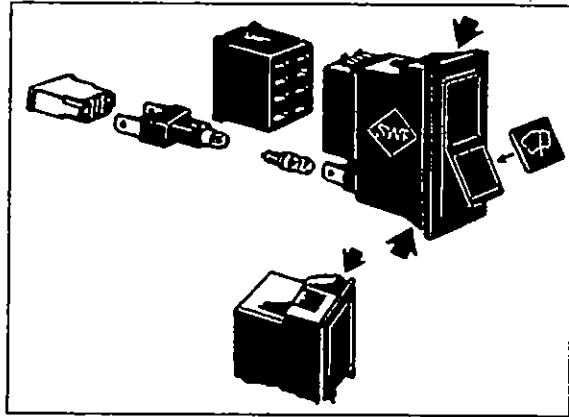

Figure 46

06092

#### 12.1.2 Indicator Light Bulb Replacement

1. Remove dashboard housing by removing the two screws (one on each side of the dashboard).
2. Locate the defective light.
3. Access bulb by pulling out socket while applying lateral pressure.
4. Pull defective bulb out of socket and replace with a new one.
5. Replace socket in light housing.
6. Replace dashboard housing.

**Note:** The bulbs of the "Check engine" and "Stop engine" warning lights, as well as those for the flasher indicator lights, are 12 volts instead of 24 volts, as in the case of all other indicator/warning lights.

#### 12.1.3 Gauge Light Bulb Replacement

1. For any gauge light bulb replacement, the rear dashboard housing must be removed in order to have access to the rear of gauges.
2. Remove bulb socket from the gauge, turn the defective bulb counterclockwise and pull it out of the socket.
3. Push a new bulb into the socket and turn clockwise to lock in place.
4. Replace bulb socket in gauge and replace the rear dashboard housing.

### 12.1.4 Panel Light Bulb Replacement

Panel light bulbs are mounted in sockets under the dashboard panel and serve to illuminate control switches such as the heating and A/C switches.

1. To replace a panel light bulb, the rear dashboard housing must be removed.
2. Push and turn the bulb counterclockwise and pull it out of the socket.
3. Install the new bulb in the socket. Push and turn clockwise to lock in position.
4. Replace the rear dashboard housing.

## 12.2 Stepwell Lights

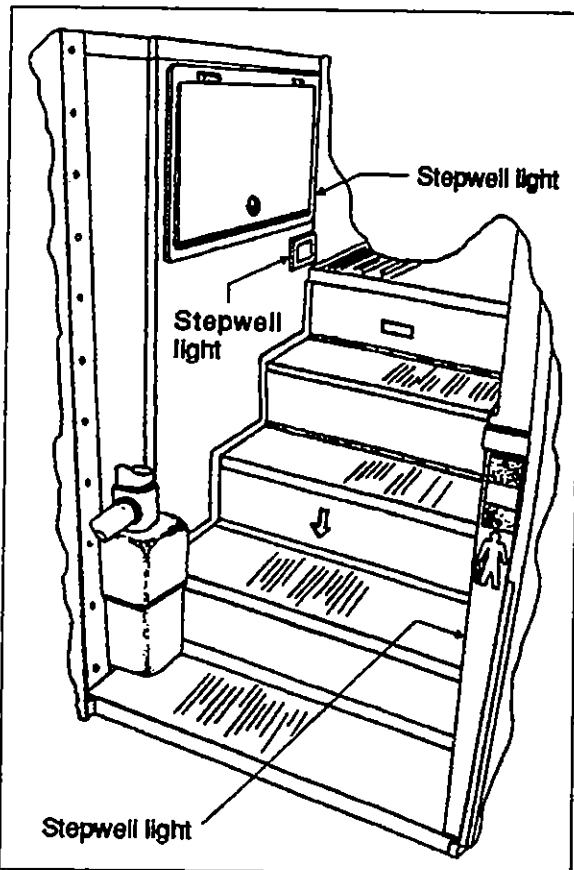

Figure 47

06094

Stepwell lights are illuminated when the door opening system is activated. The light bulbs are accessible after removal of the light lens which is held to the housing with two Phillips-head screws.

### 12.2.1 Bulb Removal and Replacement

1. With the light lens removed, pull bulb from the lamp while applying lateral pressure.
2. Install the new bulb into the lamp.
3. Position the light lens and install it.

## 12.3 Dome Lights

Two dome lights (each provided with two bulbs) are installed over the stepwell and the driver's compartment. These lights are frequently used for nighttime operation when passengers board or leave coach.

### 12.3.1 Bulb Removal and Replacement

1. Unsnap the lens with a flat head screwdriver and remove it.
2. Push and turn the defective bulb counterclockwise, then pull it out of the socket.
3. Install the new bulb by pushing and turning clockwise until it locks in position.
4. Replace the lens and snap it back in place.

## 12.4 Passenger Section Lighting

The passenger section of vehicle is lit by two types of fluorescent tube lamps installed on parcel racks.

The aisle bulb lights are located on front of parcel racks, while fluorescent lights for general and in-station lighting are located under the parcel racks. A dual power system is available for this lighting either from the 24 volt vehicle power supply or from a 110 volt outlet supply. In order to save batteries during extended periods of in-station lighting, no current is drawn from the batteries as soon as the 110 volt circuit is connected.

Moreover, adjustable reading lamps are installed under parcel racks for passenger accommodation.



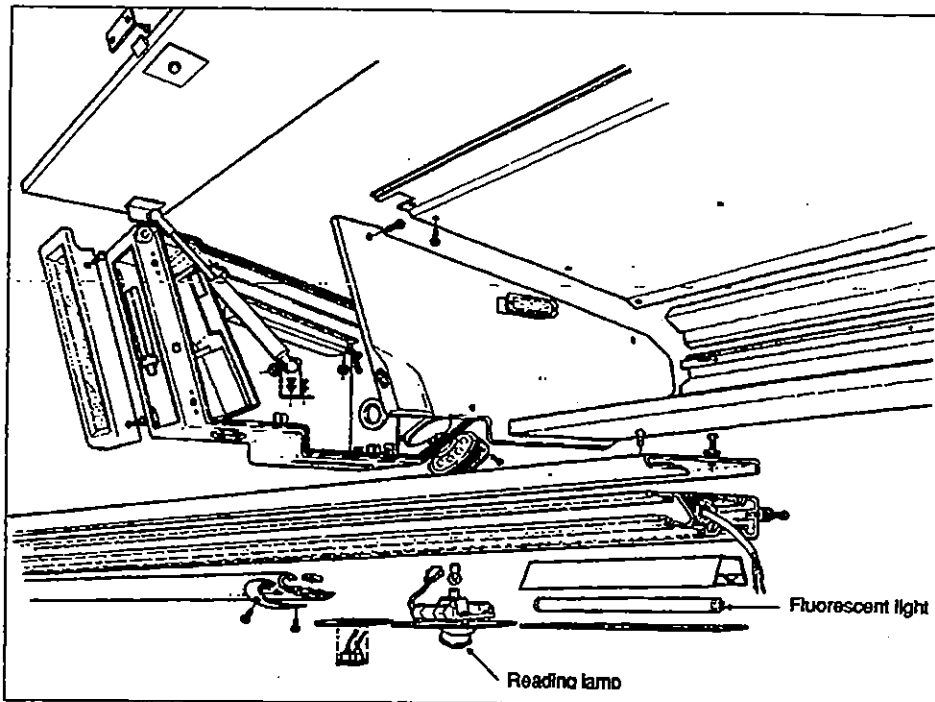

Figure 48

06095

#### 12.4.1 Removal and Replacement of Aisle Fluorescent Light

1. Remove the front bezel by unscrewing the four "Phillips" side screws (two each side), then the lens.
2. Pull the fluorescent light out of its base.
3. Install a new fluorescent light and push in until the proper position is reached.
4. Replace lens bezel.
5. Turn over the reading lamp and unscrew both screws of the retaining socket support.
6. Push and turn bulb counterclockwise, then pull it out of the socket.
7. Install new bulb in the socket, then push and turn clockwise to lock bulb in position.
8. Install retaining socket support and screw.
9. Position the reading lamp and press until it snaps.

#### 12.4.2 Removal and Replacement of Fluorescent Light

1. Apply pressure on the screen lens of fluorescent light to unsnap it.
2. Rotate and pull the fluorescent light from its socket.
3. Install the new fluorescent tube, rotating the tube to secure it in its socket.

#### 12.4.3 Removal and Replacement of Reading Lamp Bulb

1. Slide the reading lamp slightly and pull in order to unsnap it.

### 12.5 Engine Compartment Lighting

Three engine compartment lights controlled by a microswitch upon opening of the engine door, are provided in the engine compartment; two are circular while the other is the same sealed unit as used to illuminate the license plate.

#### 12.5.1 Circular Light

Each light is provided with one bulb which can be replaced as follows:

## Section 6: ELECTRICAL SYSTEM

1. Remove the lens by prying out with a flat screwdriver.
2. Push and turn the defective bulb counterclockwise, then pull it out of the socket.
3. Install the new bulb in the socket, then push and turn clockwise to lock bulb in position.
4. Install the lens, and snap it in place.

### 12.5.2 Sealed Unit Light

In case of burn out, the sealed unit must be changed in accordance with the following procedure:

1. Pry the sealed unit out of its receptacle fixture by inserting a small flat screwdriver at one extremity, then pull on the sealed unit and disconnect it.
2. Reconnect new sealed unit, and press on it until it is seated in its former position.

## 13. LIGHT BULB DATA

When replacing a light bulb, special attention must be paid to the voltage rating (refer to light bulb data hereafter).

**Note:** All exterior lights are 12 volts and all interior lights are 24 volts, except for the "Check engine" and "Stop engine" warning lights and flasher indicator lights which are also on 12 volt system.

Application	Prévoist part no.	Trade or SAE Number	Watts or Candle Power	Volts	Qty
<b>EXTERIOR LIGHTING</b>					
Hi-beam	561198	H4651	50 W	12	2
Low-beam	561199	H4656	35 W	12	2
Docking & cornering	561882	H3 (Osram)	55 W	12	4
Fog	561882	H3 (Osram)	55 W	12	2
License plate (sealed)	930266	—	—	12	2
Side directional	930301	Sealed	2 cp	12	6
Side marker	930304	Sealed	2 cp	12	2
	930301	Sealed	2 cp	12	4
Identification	562059	194	2 cp	12	6
Clearance	562059	194	2 cp	12	8
Front directional (hazard and marker)	561899	1157 NA	32/6 cp	12	2
Rear directional	561880	Hella	21 W	12	4
Stop	561880	Hella	21 W	12	4
Back-up	561880	Hella	21 W	12	4
Center stop	561880	Hella	21 W	12	1
Tail	561881	Hella	10 W	12	4
Exterior compartment (except engine)	562278	6429 (78207)	10 W	24	A/R
Engine compartment	561917	1683	32 cp	24	2
	930209	—	—	24	1

INTERIOR LIGHTING					
Check engine	562048	E-9 (Norma)	2 W	12	1
Stop engine	562048	E-9 (Norma)	2 W	12	1
Flasher indicator	562048	E-9 (Norma)	2 W	12	2
Other indicator (1/unit)	562049	(Osram)	2 W	24	AIR
Speedometer	560145	1829	1 cp	24	2
Tachometer	560145	1829	1 cp	24	2
Turbo boost	561167	3899 (Osram)	3 W	24	1
Tachograph	561006	1-405-804	1.2 cp	24	3
Other instrument (1/unit)	560144	1820	1.6 cp	24	AIR
Step	562278	6429	10 W	24	3
Lavatory	562278	6429	10 W	24	1
Parcel rack	560144	1820	1.6 cp	24	AIR
Driver's area	561553	78236	10 W	24	4
"EMERGENCY EXIT" decal	560601	456	2 cp	24	20
"LAVATORY OCCUPIED"	560144	1820	1.6 cp	24	2
"WATCH YOUR STEP"	560144	1820	1.6 cp	24	2
Aisle	560141	1251	3 cp	24	6
Switch (1/unit)	561123	2741 (Osram)	1 W	24	AIR
Reading	562033	961-4940	8 W	24	AIR
Fluorescent	830102	F15T8CW	15 W	--	AIR
Lavatory fluorescent	830102	F15T8CW	15 W	--	2
Destination sign fluorescent	830080	F30T8CW4	20 W	--	1
Parcel rack front neon	830108	PL7	7 W	--	AIR
R.H. lateral console	562278	6429 (78207)	10 W	24	1

## 14. SPECIFICATIONS

### BATTERY

Make .....	Delco-Remy
Model .....	1150
Type .....	Maintenance-free
Terminal type .....	Top Stud
Group size .....	31
Volts .....	12
Load test amperage* .....	290
Reserve capacity (minutes).....	180

### Cold cranking (in amps)

- At 0 °F (-18 °C) .....	625 (each battery)
- At -20 °F (-29 °C).....	490 (each battery)

### Maximum dimensions (inches/mm)

- Length (including flange).....	13.0/330,2
- Width.....	6.8/172,7
- Height (including top posts).....	9.4/238,8
- Approximate weight (lbs/kg).....	60/27,2

\* Battery tester cable clamps should be between terminal nuts and lead pads of terminals. If not possible, load value should be 210 amperes.

**Section 6: ELECTRICAL SYSTEM**

**Torque specifications**

Battery cable to post..... 10-15 lbf-ft (13-20 N·m)  
Battery cover ..... 45-50 lbf-ft (5-6 N·m)

**ELECTRICAL SYSTEM MONITOR**

Make ..... Vanner  
Model ..... EM-70  
Input ..... 24 V dc  
System high ..... Greater than 30 V dc  
System low ..... Less than 24 V dc  
Trip level .....  $\pm 0.75$  V dc  
Prévost Number ..... 56-2058

**ALTERNATOR**

Make ..... Delco-Remy  
Model Number ..... 1117702  
Series ..... 50 DN  
Type ..... 600  
Field current at 80 °F (27 °C)  
- Amperes ..... 7.2 - 8.0  
- Volts ..... 24  
Hot output  
- Amperes ..... 270 at 80 °F (27 °C) ambient  
- Volts ..... 28  
- Approximate rpm ..... 3000  
Ground ..... Negative  
Prévost Number ..... 56-1723

**REGULATOR**

Make ..... Delco-Remy  
Model Number ..... 1118447  
Type ..... Transistor  
Voltage adjustment ..... External screw  
Prévost Number ..... 56-0030

**BATTERY EQUALIZER**

Make ..... Vanner  
Model ..... 60-50A  
Amperes ..... 50 amps  
Prévost Number ..... 56-1016

**STARTING MOTOR**

Make ..... Delco-Remy  
Model Number ..... 1990269  
Series ..... 50 MT  
Type ..... 400  
Rotation (viewing drive end) ..... CW  
Brush tension ..... 5 lbs (2,2 kg) Min.  
Voltage ..... 24

**No-load test**

- Volts ..... 23  
- Min. current draw ..... 60 amperes  
- Max. current draw ..... 90 amperes  
- Min. rpm ..... 7000 rpm

**STARTING MOTOR SOLENOID**

Make ..... Delco-Remy  
Model Number ..... 1115557  
Current Draw 80 °F (27 °C)  
- Hold-in winding ..... 7.35 - 8.2 amps  
- Pull-in winding ..... 48 - 54.5 amps  
Volts ..... 24







# VANNER WELDON INC.

4282 REYNOLDS DRIVE

HILLIARD, OHIO 43026

PHONE: 614-771-2718

FAX: 614-771-4904

---

## How can the Ground Fuse blow in a 60-100C?

The blown fuse in the 60-100C is usually a rare problem. The 60-100C has been designed with circuits to monitor the DC input voltages and 12 volt output current. The circuits only close the relays to the power circuits when the proper conditions are met. The proper conditions to turn the unit ON are 1) the 24 volt terminal greater than 18 volts, 2) the 12 volt terminal greater than 8 volts AND 3) the 12 volt terminal less than 48% of the 24 volt terminal. Once the unit is ON the unit regulates the 12 volt terminal at 50% of the 24 volt terminal  $\pm$  a small tolerance. The conditions which turn the unit OFF are 1) the 24 volt terminal less than 18 volts, 2) the 12 volt terminal less than 8 volts OR 3) the 12 volt terminal drops to less than about 3 amps.

To blow the fuse, the 60-100C must be in the ON mode and someone disconnects the battery ground connection from the chassis. If the 60-100C ground connection is still connected to the chassis and the 60-100C was ON it will remain ON until the 12 volt load drops below 3 amps or the voltage between the 24 and ground terminals goes less than 18 volts.

The unit is basically simulating the Battery "A" thus does not see the 12 to ground terminals drop below 8 volts. Should a 12 volt load greater than 3 amps remain on, the unit remains ON.

Now if a large 24 volt load (starter, wrench, wires, etcetera) is connected from Battery "B" positive to chassis ground the 60-100C supplies full output current but can no longer simulate Battery "A". The voltage 12 terminal to ground collapses and then reverses since the vehicle chassis is now at +24 volts (DC meter negative lead connected to Battery "A" negative, DC meter positive lead connected to chassis). Before the relays can disconnect the power circuit the ground fuse may blow.





# TROUBLESHOOTING GUIDE

for the  
**60-100C**

## **THEORY of OPERATION:**

The Battery Equalizer is an energy transfer device. It allows power to be taken from a 24 volt battery system at 12 and 24 volts simultaneously. The Equalizer is designed to be connected to the batteries continuously much like an alternator. The amount of continuous duty 12 volt current is limited by the size of the Equalizer. The Equalizer causes the 12 volt current draw to be taken from both the batteries of the 24 volt system. For example; if a 10 amp, 12 volt load is presented to the system, 5 amps would be supplied by each of the batteries.

This Battery Equalizer has been designed with some extra energy conservation circuits as compared with our already very efficient 10, 20 and 50 amp units. These energy conservation circuits allowed the 100 amp unit to fit the general footprint of the 50 amp unit. The 60-100C does have some unique characteristics due to these energy conservation circuits. Therefore, the test procedure you may have used for a 10, 20 and 50 amp unit **DOES NOT** properly test a 60-100C.

The following test is for the 60-100C only. Although the basic procedure would work for our other Battery Equalizers, the current levels specified here have been selected specifically for the 60-100C. Several things are important for proper system operation. Verify that all connections are secure. The resistance of each of the wires between the 60-100C and the battery terminals is also important. #2 AWG is good for 5.2 feet or less. #1 is good for 6.5 feet or less. #1/0 is good for 8.3 feet or less. And #2/0 is good for 10.5 feet or less. The lengths listed here assumes each of the three wires are the specified length or shorter. If there are any questions about the wire lengths and sizes, please call or write us.

## **EQUIPMENT NEEDED:**

- A Charging/Starting System Tester capable of providing 0 to 150 amp variable 12 volt load.
- A clamp-on style ammeter probe capable of measuring 150 amps. This may be part of the System Tester.
- A hand held or bench type Digital DC voltmeter (multimeter). This should be separate from the System Tester.

# TROUBLESHOOTING GUIDE

for the  
60-100C

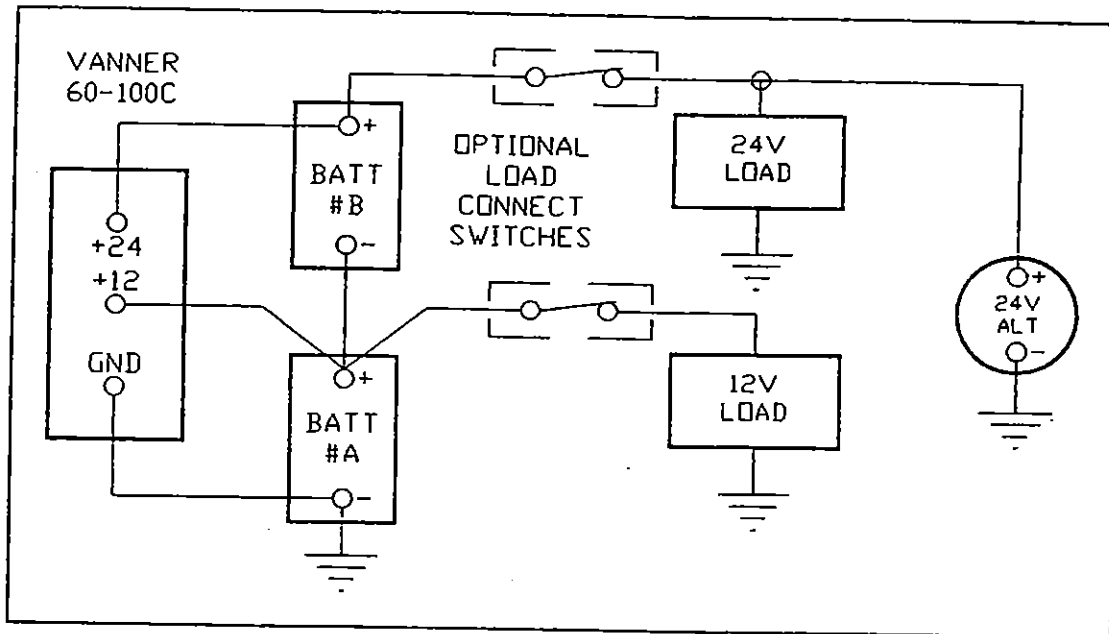

Typical System Wiring Diagram

## TEST PROCEDURE:

- When this procedure refers to ground, it means the ground terminal on the 60-100C, NOT the chassis ground. All voltage measurements refer to the screw terminals of the 60-100C. As the measurement points are described, the voltmeter positive lead will be first point and the negative lead will be the second point listed. There will be times the voltmeter negative lead is connected to +12 circuits.
- Set the load of the System Tester to 0 amps. Connect this load to Battery "A".
- Install the clamp-on ammeter probe around the wire that connects between the 60-100C +12 post and Battery "A" positive post. The current we will measure will flow from the 60-100C to the Battery "A" positive post. Make sure the probe is installed expecting this direction of current flow or the ammeter will display a negative current when the 60-100C turns On.
- Start the engine and verify the "system voltage" by measuring +24 to ground. It should be between 25.5 Vdc and 28.5 Vdc. Write this measured voltage on a note pad.
- Divide this system voltage by 2 to determine the "target voltage". Multiply the system voltage by 0.48 to determine the "activate voltage". Example: If the measured

# TROUBLESHOOTING GUIDE

## for the 60-100C

voltage is 27.0 Vdc, then the target voltage is  $27 + 2 = 13.5$  and the activate voltage is  $27 \times 0.48 = 12.96$ .

- F. Connect the DC voltmeter +12 to ground.
- G. If the ammeter indicates more than 2 amps of current, adjust the System Tester for a 10 amp reading. If the load can be adjusted for a 10 amp reading, then skip directly to Step J of this procedure.
- H. Adjust the System Tester load so the voltmeter reads less than the activate voltage and higher than 9 volts. It may be necessary to reduce the load as the voltage drops so the meter never reads less than 9 volts.
- I. The 60-100C should start operating within 25 seconds. Operation is verified by observing current flow shown on the clamp-on ammeter.
- J. Adjust the load so the ammeter shows 95 amps of current.
- K. Again measure the system voltage, write it on a note pad and divide it by 2 to determine the new target voltage with the load applied.
- L. Measure the DC voltage from +12 to ground.
- M. Subtract the voltage just measured from the calculated value. This calculation will be less than 0.35 volts on a properly operating 60-100C.
- N. Reduce the load so the current drops to 10 amps and then slowly reduce the load while watching the current. Somewhere between 4 and 1.5 amps the current will suddenly drops to zero. This is the point where the unit has gone into its energy conservation mode. The voltage, +12 to ground, will have to drop below the activate voltage for 25 seconds to get the unit to turn On again.

Should a unit fail the above tests, contact Vanner Weldon for further assistance or send the unit to the address below with a note. Include your name, phone number, shipping address (UPS can not deliver to a P.O. Box) and any information about the unit and its use.

### VANNER WELDON INCORPORATED

4282 Reynolds Drive

Hilliard, Ohio 43026 U.S.A.

Phone: 614-771-2718,

FAX: 614-771-4904

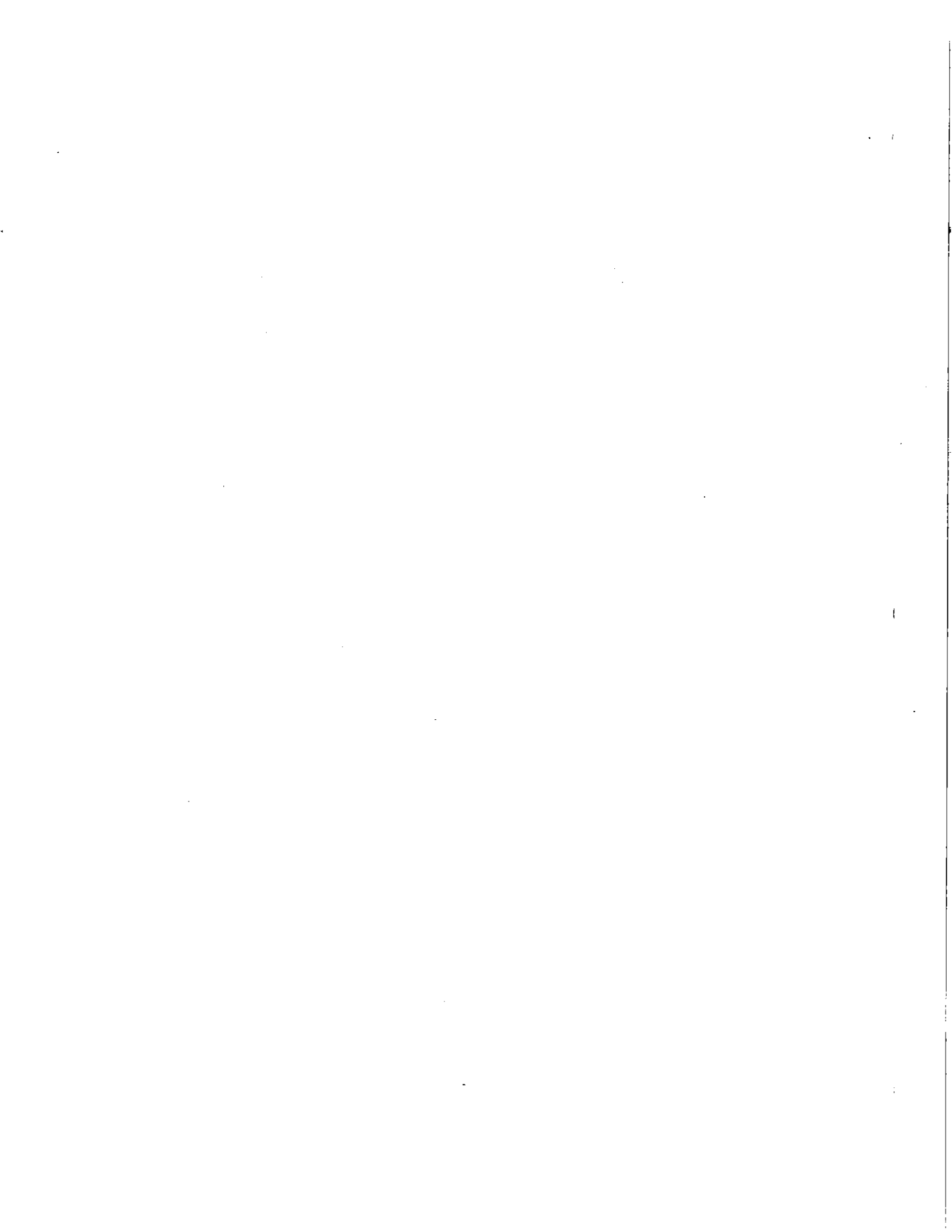

# TROUBLESHOOTING GUIDE

## For VANNER Equalizers

Models 60-10A, 60-10B, 60-20, 60-20A, 60-50, 60-50A and 60-50E

### THEORY OF OPERATION

The Battery Equalizer is an energy transfer device. It allows power to be taken from a 24 volt battery system at 12 and 24 volts simultaneously. The Equalizer is designed to be connected to the batteries continuously much like an alternator. The amount of continuous duty 12 volt current is limited to the size of the Equalizer. The Equalizer causes the 12 volt current draw to be taken from both the batteries of the 24 volt system. For example, if a 10 amp, 12 volt load is presented to the system, 5 amps would be supplied by each of the batteries. Any imbalance between the batteries is automatically equalized.

### TROUBLESHOOTING

1. Carefully remove the ground (GND) cable from the Equalizer. Do not allow this cable to touch any other connection on the Equalizer because the other terminals are connected to the batteries.
2. Make sure there is approximately 12 volts between the +24 and +12 terminals of the Equalizer by momentarily connecting the two terminals of a 12 volt light (headlight, marker light, etc.) to the +24 and +12 terminals of the Equalizer. The light should light and stay lit.
3. Next, connect that same 12 volt load between the +12 and GND terminals of the Equalizer. The lamp should light and stay lit. If the lamp does not light, is not as bright as in Step 2, or light and then goes out, the Equalizer requires repair.
4. Further verification may be made by measuring the voltages on the Equalizer terminals.
5. Measure the voltage between +24 and +12 terminals. Write this reading on a notepad.
6. Measure the voltage from the +12 terminal to GND. Write this reading below the number from Step 5.
7. Compare the two readings by subtracting the +12 to GND reading from the +24 to +12 reading. A properly functioning Equalizer is one where the difference is between -0.5 and +0.13 volts. For example, the +24 to +12 reading might be 12.85 volts. The +12 to GND voltage might read 12.75 volts. This Equalizer would be functioning properly with a 0.10 difference (12.85 minus 12.75 volts) which is within specifications.

Vanner offers a quick turn around repair service. Send the unit to the address below with a note instructing us to repair it. Include your name, phone number, shipping address (not a P.O. Box Number), and a note asking us to call you with an estimate. The 60-100C DOES NOT test properly using this test procedure. Use Troubleshooting Guide A95077 for the 60-100C.

VANNER WELDON INC.

4282 Reynolds Drive Hilliard, Ohio 43026  
Phone: 614-771-2718 FAX: 614-771-4904

## Typical 24/12 VDC System

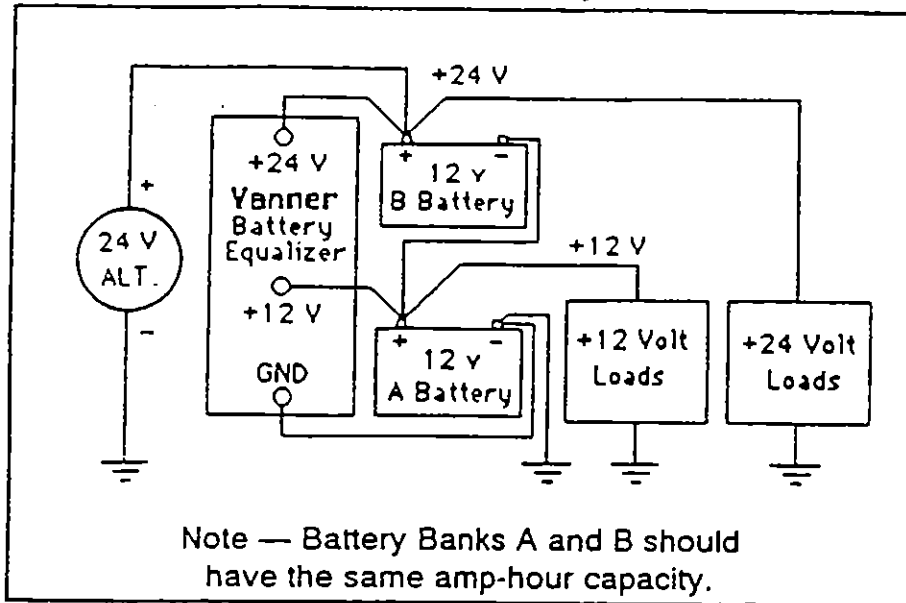

**Recommended wire size for Vanner Series 60 Battery Equalizers.**

Wire Size AWG	Maximum wire length, in feet, between the Vanner Equalizer and the battery in an effort to keep wiring losses less than 0.1 volts and assuming the wire temperature is less than 80°C and no other loads.					
	60-10A or B	60-20A	60-50A	2 x 60-50A	3 x 60-50A	4 x 60-50A
#14	3.2	x x x	x x x	x x x	x x x	x x x
#12	5.0	2.5	x x x	x x x	x x x	x x x
#10	7.7	3.8	x x x	x x x	x x x	x x x
#8	12.8	6.4	2.6	x x x	x x x	x x x
#6	19.4	9.7	3.9	x x x	x x x	x x x
#4	35.2	17.6	7.0	3.5	2.3	x x x
#2	51.9	26.0	10.4	5.2	3.5	2.6
#1	65.4	32.7	13.1	6.5	4.4	3.3
#1/0	82.9	41.4	16.6	8.3	5.5	4.1
#2/0	105.5	52.7	21.1	10.5	7.0	5.3

### IMPORTANT NOTE

The Vanner *VoltMaster* Battery Equalizer is an extremely reliable device, and when installed according to the instructions, will provide reliable operation for an indefinite period of time. However, if a system abnormality should develop that would cause a Battery Equalizer malfunction, damage to the battery system could possibly result if 12 volt loads are present. If your system application is critical you may consider installing a Vanner Model EM-70 Electrical System Monitor. This module monitors the battery system's voltages and balance, and provides fault signals that can be wired to warning lights, buzzers or other control/warning devices. For more details refer to Vanner Product Bulletin 206.

# SECTION 07: TRANSMISSION

## CONTENTS

1. DESCRIPTION.....	2
1.1 Manual Transmission .....	2
1.2 Automatic Transmission.....	2
1.2.1 Retarder .....	2
2. WELDING PROCEDURES .....	2
3. MAINTENANCE .....	3
3.1 Manual Transmission .....	3
3.1.1 Oil Recommendations .....	3
3.1.2 Oil Check.....	3
3.1.3 Oil Change .....	4
3.1.4 Metal Particles.....	4
3.2 Automatic Transmission .....	4
3.2.1 Cold Check.....	5
3.2.2 Hot Check .....	5
3.2.3 Readout of the Oil Level Sensor.....	6
3.2.4 Keeping Oil Clean .....	6
3.2.5 Oil Recommendations .....	6
3.2.6 Oil Contamination.....	8
3.2.7 Metal Particles.....	8
3.2.8 Coolant Leakage.....	8
3.2.9 Oil and Filter Change.....	8
4. GEAR SHIFT LINKAGE (Manual Transmission) .....	9
4.1 Adjustment.....	9
4.2 Lubrication .....	9
5. TRANSMISSION REMOVAL.....	9
5.1 Automatic Transmission.....	9
5.2 Manual Transmission.....	10
6. MANUAL TRANSMISSION DISASSEMBLY AND REASSEMBLY.....	11
7. CLEANING AND INSPECTION OF THE TRANSMISSION .....	12
7.1 Automatic Transmission .....	12
7.1.1 Breather.....	12
7.2 Manual Transmission .....	12
7.2.1 Cleaning .....	12
8. TRANSMISSION INSTALLATION.....	12
8.1 Automatic Transmission.....	12
8.2 Manual Transmission.....	14
9. ALLISON TRANSMISSION PRINCIPLES OF OPERATION .....	15
10. TROUBLESHOOTING.....	15
10.1 Manual Transmission .....	15
10.2 Automatic Transmission.....	15
10.2.1 Diagnostic Code Memory .....	15
11. SPECIFICATIONS .....	30

## **1. DESCRIPTION**

H3 vehicles may be provided with either a manual or an automatic transmission.

### **1.1 Manual Transmission**

The Spicer PS130-6B, 6-speed, has 6 forward speeds and 1 reverse speed.

The Spicer PS145-7A, 7-speed, has 7 forward speeds and 1 reverse speed.

### **1.2 Automatic Transmission**

The B500(R) world transmission has 6 speeds with two top range (fifth and sixth) overdrives. Total coverage is determined by dividing the highest gear ratio by the lowest gear ratio. Total coverage expresses the transmission gear ratio versatility. Transmissions with larger total coverage number have a wider variety of available ratios.

An electronic control allows the transmission to shift at exactly the right point on the engine's fuel consumption curve for best economy. Early lockup maintains the highest possible mechanical efficiency through the closely-spaced gear steps, culminating in two overdrive ratios. This combination allows progressive shifting techniques, where engine speeds are reduced for higher efficiency and lower fuel consumption.

Gear selection and torque converter modes are controlled by a microcomputer-based electronic transmission management system. It is fed information regarding throttle position, operator range selection, engine speed, turbine speed, transmission output speed and various system pressures from special electronic sensors. With this information, it computes shift points and clutch pressures to meet immediate needs. Using closed loop adaptive logic, the electronic control looks at a number of parameters during the shift, and makes minute adjustments to match the shift to desired profile stored in its memory. It then looks at these adjustments and resets the parameters which allow the transmission to quickly compensate for variations in load, terrain or

environment, and to adjust for clutch wear and engine power changes. A diagnostic Data Reader can be connected to the electronic control unit to provide a self-check of all systems in the transmission. Four-digit trouble codes greatly reduce the time it takes to pinpoint potential problems. (Refer to heading "Troubleshooting" of this section).

#### **1.2.1 Retarder (if applicable)**

This optional auxiliary braking device for the automatic transmission is integrated into the basic envelope of the transmission and transmits its braking force directly to the propeller shaft. It requires no additional length and adds only 75 pounds (34 kg) of weight. Operation of the retarder is controlled electronically by the driver's use of the brake and/or by hand control lever. When activated, fluid enters a cavity and provides resistance to the turning of rotor blades revolving with the output shaft. This effectively slows the vehicle to the point where the service brakes are needed only for final stopping. The retarder is fully modulated and is compatible with ABS.

## **2. WELDING PROCEDURES**

These procedure are intended for vehicles equipped with transmission electronic controls. When frame or other welding is required on the vehicle, the following precautions are to be taken to protect the electronic control components:

1. Disconnect the wiring harness connectors at the transmission electronic control unit.
2. Disconnect the positive and negative battery connections, and any electronic control ground wires connected to the frame or chassis.
3. Cover electronic control components and wiring to protect from hot sparks, etc.
4. Do not connect welding cables to electronic control components.



### 3. MAINTENANCE

#### 3.1 Manual Transmission

##### 3.1.1 Oil Recommendations

The following lubricants are recommended in order of preference.

TEMPERATURE	GRADE	TYPE
Above 0°F (-18°C) Below 0°F (-18°C)	SAE 30, 40, or 50 SAE 30	Heavy Duty Engine Oil meeting MIL-L-2104D or MIL-L-46152 B, API-SF or API-CD specifications (MIL-L-2104 B & C, OR 46152 are also acceptable)
Above 0°F (-18°C) Below 0°F (-18°C)	SAE 90 SAE 80	Straight Mineral Gear Oil R & O Type API-GL-1
Above 0°F (-18°C) Below 0°F (-18°C)	SAE 90 SAE 80	* Mild EP Gear Oil MIL-L-2105 or API-GL-4
All	CD SAE 50 CD SAE 30	Synthetic Engine Oil meeting MIL-L-2104 D or MIL-L-46152 B, API-SF or API-CD specifications
All	EP SAE 75W90 EP SAE 75W140	* Synthetic Gear Oil meeting MIL-L-2105C or API-GL5 specifications

\*EP gear oils are not recommended when lubricant operating temperatures are above 230°F (110°C).

##### 3.1.2 Oil Check

Manual transmission oil should be checked when engine is stopped and cold.

**Warning:** Before servicing the coach, park safely over a repair pit, apply parking brake, stop engine and set battery master switch to the off position.

Unscrew the fill plug and verify if the oil level is at plug thread level (Fig.1).

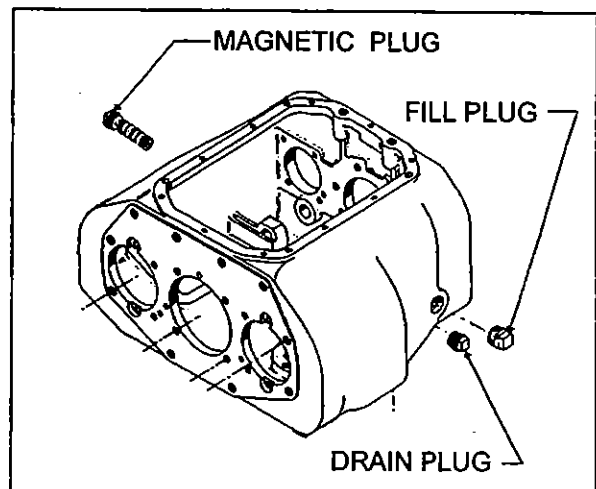

Figure 1: Plugs

07010

### 3.1.3 Oil Change

#### OIL CHANGE INTERVALS

Change break-in oil after 3,000 miles (4 800km) of initial operation, then every 6,250 miles (10 000 km) or once a year, whichever comes first.

#### Drain manual transmission as follows :

1. Unscrew the drain plug (Fig.1) and allow the oil to drain into a suitable container.
2. Inspect plug and replace if necessary. Reinstall plug.

#### Refill manual transmission as follows :

1. Remove fill plug.
2. Add oil until it overflows.
3. Clean oil from the transmission case and the fill plug.
4. Reinstall plug.

**Caution:** Do not overfill transmission. Oil breakdown due to excessive heat and/or sludge deposits impairing proper operation of transmission may result.

### 3.1.4 Metal Particles

The magnetic plug attracts metal particles. When metal particles are of abnormal size, the transmission must be disassembled

## 3.2 Automatic Transmission

To gain access to the dipstick, open the engine compartment rear door. The dipstick is located beside the engine (Fig. 2).

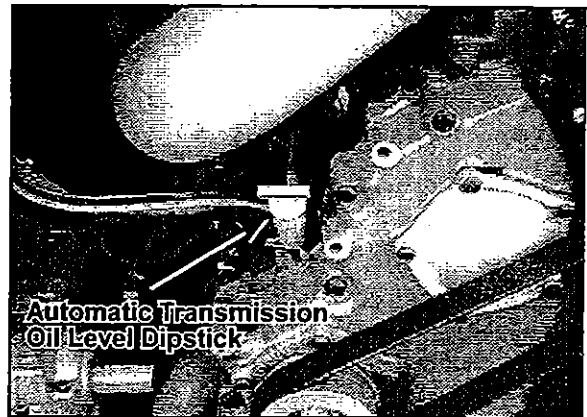

Figure 2: Oil Level Dipstick

OEHB706

To check the transmission oil level, a cold check and a hot check must be performed. A cold check must be made between 60°F (16°C) and 140°F (60°C). The transmission oil temperature gauge indicates the operating temperature and it is located in the driver's area on the central dashboard with tachograph.

**Note:** Perform the cold check first to verify the transmission oil level before performing the hot check.

The hot check can be performed when the transmission oil reaches the normal operating temperature of 160°F (71°C) to 200°F (93°C).

Clean all dirt from around the end of the oil fill tube before removing the dipstick. Dirt or foreign matter must not be permitted to enter the oil system since it will cause valves to stick, undue wear of transmission parts, and clogged passages. Check the oil level in accordance with the following procedures and record any abnormal level on your maintenance records.

**Warning:** When checking the oil level, be sure that the parking brake and/or emergency brakes are set and properly engaged, and the wheels are chocked. Unexpected and possible sudden vehicle movement may occur if these precautions are not taken.

Always check the oil level reading at least twice when the engine is running. Consistency is important in maintaining the accuracy of the reading. If inconsistent readings persist, check the transmission breather to ensure it is clean and free of debris.

### 3.2.1 Cold Check

1. Park the vehicle on a level surface and apply the parking brake.

**Caution:** The oil level rises as sump temperature increases. DO NOT fill above the "Cold Run" band if the transmission oil is below normal operating temperature.

2. Run the engine for at least one minute. Shift to Drive (D) and then to Reverse (R) to clear the hydraulic circuits of air. Then shift to Neutral (N) and allow the engine to idle (500 - 800 rpm).
3. While the engine is running, remove the dipstick from the tube and wipe it clean (a typical dipstick is shown in Fig. 3).
4. Insert the dipstick into the tube and remove, checking the oil level reading. Repeat the check procedure to verify the reading. If the oil reading is within the "COLD RUN" band, the level is satisfactory for operating the transmission until the oil is hot enough to perform a "HOT RUN" check. If the oil reading is not within the "COLD RUN" band, add or drain oil as necessary to bring the level to the middle of the "COLD RUN" BAND.
5. Perform a hot check at the first opportunity after the normal operating temperature of 160°F (71°C) to 200°F (93°C) is attained.

### 3.2.2 Hot Check

**Caution:** The oil must be hot to ensure an accurate check for this procedure. The oil level rises as temperature increases.

1. Operate the transmission in drive range until normal operating temperature is reached 160°F (71°C) to 200°F (93°C).
2. Park the vehicle on a level surface and shift to neutral. Apply the parking brake and allow the engine to idle (500 - 800 rpm).
3. While the engine is running, remove the dipstick from the tube and wipe it clean.
4. Insert the dipstick into the tube and remove, checking the oil level reading. Repeat the check procedure to verify the reading.

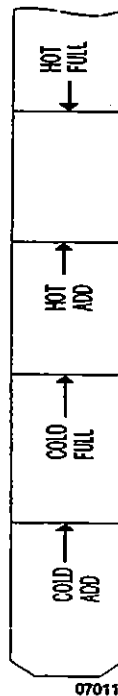

Figure 3:  
Dipstick

The safe operating level is anywhere within the "HOT RUN" band on the dipstick. (Typical dipsticks are shown in Figure 3).

5. If the oil level is not within the "HOT RUN" band, add or drain oil as necessary to bring the oil level within the band.

**Note:** The cold check is more appropriate for verifying the oil level after the first fill-up. In case of conflict, the hot check has priority over the cold check; the automatic system of verification via the shift selector has priority over the hot check.

**Section 07: TRANSMISSION**

**3.2.3 Readout of the Oil Level Sensor**

The oil level sensor (OLS) is designed to measure transmission oil level only when the following combination of operating conditions exist:

1. Engine must be at idle;
2. **NEUTRAL** must be selected;
3. Zero output speed;
4. Transmission oil must be within a "normal" temperature band (160-250°F; 70-120°C); and
5. Once the first four (4) conditions are met, there must be a "waiting" period (approx. 2 min., to facilitate consistent oil drainback) before oil level measurement begins.

To enter OLS readout mode (after meeting the conditions noted above), simultaneously press the UPSHIFT and DOWNSHIFT arrows on the shifter.

If the five (5) conditions noted above are present, the display will immediately enter the reading mode. If the "waiting" period has not elapsed, the left digit of the display will become a "chasing" digit and the right digit will count down from (8) to (1) until the waiting period is complete.

After attaining the reading mode, the display will flash "OL-OK", "LO-01", "HI-02", etc., where the suffix "01" or "02" indicates the volume of oil (in quarts) either low or high.

At any time in this sequence, simultaneously pressing the UPSHIFT and DOWNSHIFT arrows directs the ECU to enter the transmission diagnostic mode as described under "10. Troubleshooting" in this section. D, N, or R may also be selected on the shifter at any time - the OLS mode will abort and normal transmission will commence. Shifts are not inhibited.

**Oil Level Sensor (OLS) Codes**

<u>CODE</u>	<u>CAUSE OF CODE</u>
OL-OK	Oil Level Is Correct
LO-01	One Quart Low

LO-02	Two Quarts Low
HI-01	One Quart High
HI-02	Two Quarts High
OL-50	Engine Speed (RPM) Too Low
OL-59	Engine Speed (RPM) Too High
OL-65	Neutral Must Be Selected
OL-70	Sump Oil Temperature Too Low
OL-79	Sump Oil Temperature Too High
OL-89	Output Shaft Rotation
OL-95	Sensor Failure

**3.2.4 Keeping Oil Clean**

Oil must be handled in clean containers, fillers, etc., to prevent foreign material from entering the transmission. Lay the dipstick in a clean place while filling the transmission.

**Caution:** Containers or fillers that have been used to handle antifreeze or engine coolant must NEVER be used for handling transmission fluid. Antifreeze and coolant solutions contain ethylene glycol which, if introduced into the transmission, can cause the clutch plates to fail.

**3.2.5 Oil Recommendations**

Hydraulic oils used in the transmission have an important influence on transmission reliability and durability. In order of preference DEXRON-III and DEXRON-IIIE, MIL-L-2104D, and type C-4 oils (Allison approved SAE 10W or SAE 30) are recommended. Type C-4 oil is the only oil approved for use in off-highway applications. Use type SAE 30 where ambient temperature is consistently above 86°F (30°C). Some DEXRON-II oils are also qualified as type C-4 oils and may be used in off-highway applications. However, a DEXRON-II fluid which is not a qualified type C-4 oil must never be used in off-highway applications. Consult your local Allison dealer or distributor to determine if a DEXRON-II oil is also a qualified type C-4 oil.

**Section 07: TRANSMISSION**

Before using type C-4 oils, consult the vehicle manufacturer to ensure that materials used in tubes, hoses, seals, etc., are compatible with type C-4 oils. Also, consult your local Allison dealer or distributor to determine if the oil you have selected is an approved type C-4 oil. Ford Motor Company specification oils M2C33-F, M2C138-CJ and M2C166-H may be used and may be intermixed with DEXRON-II oil.

<b>OIL SPECIFICATIONS AND AMBIENT TEMPERATURE OPERATING CONDITIONS</b>	
<b>Oil type</b>	<b>Ambient temperature</b>
MIL-L-2104D, DEXRON-II, C-4	120°F (48°C) to -25°F (-32 °C)
MIL-L-46167	-25°F (-32°C) to -60°F (-51°C)

The use of an arctic preheat kit is recommended at temperatures below -25°F (-32°C). If a preheat kit is not available, the ECU will restrict full operation until the sump temperature is increased. The chart below shows the temperature ranges in which the transmission will operate. It should be noted that at lower sump temperature, the transmission's operation may be restricted.

<b>Transmission Oil Temperature</b>	<b>DO NOT SHIFT Light</b>	<b>Operation</b>
Below -26°F (-32°C)	ON	Neutral only
-24°F (-31°C) to +19°F (-7°C)	OFF	Start with neutral and reverse, normal upshifts
+20°F (-6°C) to 260°F (126°C)	OFF	Full operation in all ranges
Above 260°F (126°C)	ON	Inhibits 5th and 6th ranges

### 3.2.6 Oil Contamination

At each oil change, examine the drain oil for evidence of dirt or water. A nominal amount of condensation will emulsify during operation of the transmission. However, if there is evidence of water, check the cooler (heat exchanger) for other signs of leakage. This, however, may also indicate leakage from the engine oil system.

### 3.2.7 Metal Particles

Metal particles in the oil (except for the minute particles normally trapped in the oil filter) indicate damage has occurred in the transmission. When these particles are found in the sump the transmission must be disassembled and closely inspected to find the source. Metal contamination will require complete disassembly of the transmission and cleaning of all internal and external circuits, coolers, and all other areas where the particles could lodge.

**Caution:** *If excessive metal contamination has occurred, replacement of the oil cooler and replacement of all bearings within the transmission is recommended.*

### 3.2.8 Coolant Leakage

If engine coolant leaks into the transmission oil system, immediate action must be taken to prevent malfunction and possible serious damage. The transmission must be completely disassembled, inspected, and cleaned. All traces of the coolant contamination must be removed. Friction clutch plates contaminated with ethylene glycol must be replaced.

### 3.2.9 Oil and Filter Change

Transmission oil change must be performed with the vehicle on a flat and level surface and with parking brake applied. Oil and oil filter change frequency is determined by the severity of service and operating conditions of the transmission and by the filter equipment installed. See table 1 for oil and filter change intervals.

More frequent changes may be required when operations are subject to high levels of contamination or overheating.

**TABLE 1: OIL AND OIL FILTER CHANGE INTERVALS**

Change break-in oil after 3,000 miles (4 800 km) of initial operation and subsequently every 25,000 miles (40 000 km) or once a year, whichever comes first.

The procedure for changing the oil filters for the transmission is as follows:

#### Drain

1. The transmission should be at an operating temperature of 160°F (71°C) to 200°F (93°C) when the oil is drained. This will ensure quicker and more complete fluid drainage.
2. Remove the drain plug from under the transmission (Fig. 4) and allow the oil to drain into a suitable container. Check the condition of the oil as described previously.
3. To replace the integral filters, remove twelve bolts, two filter covers, two O-rings, two square cut seals and the two filters from the bottom of the control module (Fig. 4).
4. To install filters, pre-lube and install the two O-rings, the two square cut seals followed by the filters (lube the O-ring in filter cartridge only) into the filter compartment. Index each filter/cover assembly to holes in channel plate/sump. Push the cover assembly in by hand to seat the seals.

**Caution:** *Do not use bolts to draw the cover to sump. This can damage the cover, seal, or sump.*

5. Install six bolts into each cover and tighten to 38-45 lbf-ft (51-61 N·m).

6. Inspect the drain plug and O-ring. Replace if necessary. Reinstall the drain plug and tighten to 18-24 lbf·ft (25-32 N·m).

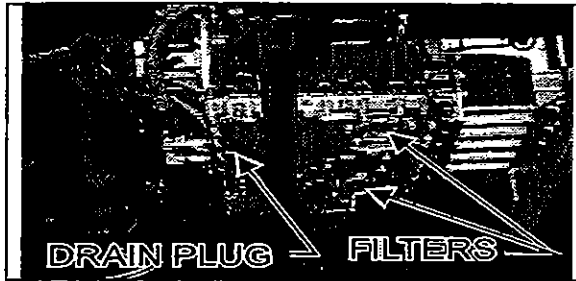

Figure 4: Plug and Filters

07012

#### Refill

Refill with 37 US qts (39 liters) and check the oil level using the previously described procedure. The refill amount is less than the initial fill because some of the oil remains in the external circuits and transmission cavities.

## 4. GEAR SHIFT LINKAGE ADJUSTMENT (Manual Transmission)

### 4.1 Adjustment

1. Put the transmission lever in "NEUTRAL" position.
2. Loosen nuts (1, Fig. 5).
3. Loosen nuts (2, Fig. 5).
4. adjustment of the gear shift lever in neutral position:
  - a. Put the shifter lever in first speed and measure the distance A on the gear shaft (3, Fig. 5).
  - b. Put the shifter lever in second speed and measure the distance B on the gear shaft (3, Fig. 5).
5. The middle position between points A and B is the "NEUTRAL" position.

6. Adjust the 1-1/5 inch (31 mm) tolerance.
7. Tighten all loose nuts (1) and (2).

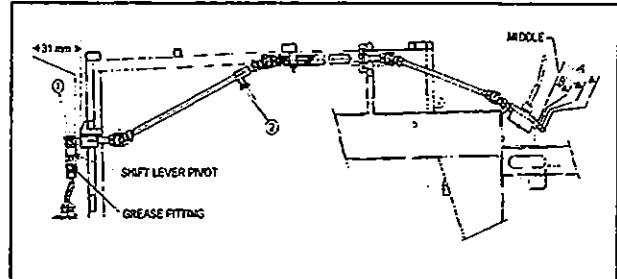

Figure 5: Gear Shift Linkage

07013

## 4.2 Lubrication

Grease with good quality lithium-base grease NLGI No.1 (Fig. 5):

- The shift lever pivot: service every 6,250 miles (10 000 km), grease 1 fitting.
- Shift control rod universal joints: service every 25,000 miles (40 000 km); grease 4 fittings.

Only during disassembly, grease the following with NLGI No.1:

1. The shift lever housing;
2. Transmission lever ball; and
3. Axle bearing.

## 5. TRANSMISSION REMOVAL

### 5.1 Automatic Transmission

The following procedure deals with the removal of the transmission without removing the power plant cradle from vehicle. The methods used to support the transmission and engine depend upon conditions and available equipment.

1. Select transmission "NEUTRAL" position, apply parking brake, then turn main battery disconnect switches to the "OFF" position.

## Section 07: TRANSMISSION

---

2. Jack up vehicle, then place safety support below body.

**Caution:** Only the recommended jacking points must be used as outlined in Section 18, BODY.

**Note:** For more clearance between the tag axle and transmission, the tag axle may be unloaded and jacked up or retracted (if applicable).

3. Remove engine splash guards surrounding transmission.
4. Remove cross member from under transmission.
5. Remove the transmission drain plug and allow oil to drain. Inspect the drain plug washer and replace it if necessary. Reinstall the drain plug and tighten to 33-41 lbf·ft (45-56 N·m) (see in this section under heading "3.2.9 Oil and Filter Change").

**Warning:** It is better to drain oil when it is still warm. Avoid contact with oil since it can be very hot and cause personal injury.

6. Remove transmission dipstick and filler tube.
7. Disconnect propeller shaft from transmission and remove its safety guard. Refer to Section 09, "Propeller Shaft".
8. Disconnect the two oil cooler hoses from transmission. Cover hose ends and fittings to prevent fluid contamination.

**Warning:** A significant amount of oil may drain from oil lines when they are disconnected.

9. Disconnect all sensors on L.H. side of the transmission.
10. Disconnect main wiring harness.

11. Disconnect the air supply line (steel-braided hose) from retarder control valve (if applicable).
12. Remove any locking tie, clamp and bracket that will interfere with removal of transmission.
13. Support transmission using a suitable transmission jack.
14. Remove the access plug from the flywheel housing on the R.H. side under the starter. From access plug, remove the 12 converter-to-flexible plate attaching screws. Turn the converter to gain access to the attaching screws.

**Caution:** Do not rotate crankshaft counterclockwise to avoid loosening the crankshaft pulley retaining screw.

15. Remove the 12 screws retaining the torque converter housing to the flywheel housing.

**Caution:** Make sure transmission-to-engine alignment is maintained when removing screws to avoid damaging torque converter housing.

16. Remove the transmission rubber mount above transmission by removing the nut, bolt and washer over the rubber and its support. Remove the bracket from transmission (only if the vehicle is equipped with a retarder).
17. Slowly pull transmission straight out to clear engine.
18. Remove the transmission.

## 5.2 Manual Transmission

The following procedures deal with the removal of the transmission without removing the power plant cradle from vehicle. The method used to support the transmission depends upon conditions and available equipment.



1. Set transmission shift lever to "neutral" position, apply parking brake, then turn main battery disconnect switches to the "OFF" position.
2. Jack up vehicle, then place safety supports below body.

**Caution:** Only the recommended jacking points must be used as outlined in Section 18, Body.

**Note:** For more clearance between the tag axle and transmission, the tag axle may be unloaded and jacked up or retracted (if applicable).

4. Remove engine splash guards surrounding transmission.
5. Remove cross member from under transmission.
6. Remove the transmission drain plug and allow oil to drain. Reinstall drain plug.

**Warning:** It is better to drain oil when it is still warm. Avoid contact with oil since it can be very hot and cause personal injury.

7. Disconnect propeller shaft from transmission and remove its safety guard. Refer to Section 09, "Propeller Shaft".
8. Remove fiberglass transmission protection.
9. Disconnect gear shift linkage as follows:
  - a. Remove the two bolts that secure the coupling lever to the shift rod (1, Fig. 5).
  - b. Push the shift rod all the way into bushing.
10. Remove return spring and disconnect yoke. Remove clutch slave cylinder from transmission without disconnecting hoses.

**Note:** Removing clutch slave cylinder will enable the release yoke to turn up and pull free from the release bearing thrust pads.

11. Disconnect speedometer sensor, back-up signal switch and neutral start switch.
12. Remove any locking tie, clamp and bracket that will interfere with the removal of transmission.
13. Support transmission using a suitable transmission jack, then remove the twelve clutch/engine mounting screws.

**Caution:** Make sure transmission-to-engine alignment is maintained when removing transmission. Do not let the rear end of transmission drop down and hang unsupported in the spline hubs of the clutch discs to avoid bending or distorting the friction discs.

14. Slowly pull transmission straight out to clear the input shaft. Remove transmission.

## 6. MANUAL TRANSMISSION DISASSEMBLY AND REASSEMBLY

Refer to the "Manual Transmission" service manual from Spicer, annexed to the end of this section.

## 7. CLEANING AND INSPECTION OF THE TRANSMISSION

### 7.1 Automatic Transmission

The exterior of the transmission should be cleaned and inspected at regular intervals. The length of service and severity of operating conditions will determine the frequency of such inspections. Inspect the transmission for:

1. Loose bolts (transmission and mounting components);
2. Oil leaks (correct immediately);
3. Loose, dirty, or improperly adjusted throttle sensor linkage;
4. Damaged or loose oil lines;
5. Worn or frayed electrical harnesses, improper routing; and
6. Worn or out of phase drive line U-joint and slip fittings.

**Caution:** *DO NOT pressure wash the transmission electrical connectors. Water and detergent will cause the contacts to corrode or become faulty.*

#### 7.1.1 Breather

The breather is located at the top of the transmission. It serves to prevent pressure build-up within the transmission and must be cleaned and have the passage opened. The prevalence of dust and dirt will determine the frequency at which the breather requires cleaning. Use care when cleaning the transmission. Spraying steam, water or cleaning solution directly at the breather can force the water or solution into the transmission. Always use a wrench of proper size to remove or replace the breather. Pliers or pipe wrench can crush or damage the stem and produce metal chips which could enter the transmission.

### 7.2 Manual Transmission

#### 7.2.1 Cleaning

**Warning:** *Use a petroleum-based solvent.*

**Warning:** *Do not use gasoline to clean parts. Gasoline can explode, causing serious physical injury.*

**Caution:** *Do not use water or steam to clean internal components. It could cause corrosion of these components.*

## 8. TRANSMISSION INSTALLATION

### 8.1 Automatic Transmission

**Note:** *For more clearance between the tag axle and transmission, the tag axle may be unloaded and jacked up, or retracted (if applicable).*

1. With the access plug removed, align one of the 12 attaching screw holes in the flexible plate with the access opening, on the R.H. side under the starter.
2. Place the transmission on a transmission jack.
3. Install a headless guide bolt into one of the 12 threaded holes for flexible plate attaching screws in the flywheel.
4. Lubricate the flywheel center pilot boss with molybdenum disulfide grease (Molycote G, or equivalent).

5. Raise transmission and position the flywheel pilot boss into the flexible plate adaptor. Align the guide bolt previously installed in the flywheel with the flexible plate hole facing the access opening in the flywheel housing.

**Warning:** Severe damages and/or personal injury can occur if transmission is not adequately supported.

6. Seat the transmission against the engine flywheel housing. NO FORCE IS REQUIRED. If interference is encountered, move the transmission away from engine, then investigate the cause.

**Caution:** The torque converter housing must be seated against the flywheel housing prior to tightening any screws. DO NOT USE SCREWS TO SEAT THE HOUSING.

7. Start all torque converter housing screws, then tighten four of them gradually and in a criss-cross sequence around the housing. Tighten the 12 remaining screws. Recommended torque is between 42-50 lbf-ft (57-68 N·m).
8. Remove the guide bolt through the access opening in the flywheel housing. Replace it with a self-locking screw, finger-tight, start the remaining screws, then tighten to 17-21 lbf-ft (23-28 N·m). Place a wrench on crankshaft pulley attaching screw to turn the converter to gain access to the threaded holes.
9. Reinstall the access plug.
10. If the vehicle is equipped with a retarder; install the bracket on the transmission and tighten the bolt to 71-81 lbf-ft (96-110 N·m). Install the transmission rubber mount between the rubber support and the frame with a bolt, nut and washer. Tighten the nut until the tolerance of  $58 \pm 2$  is met (Fig. 6).

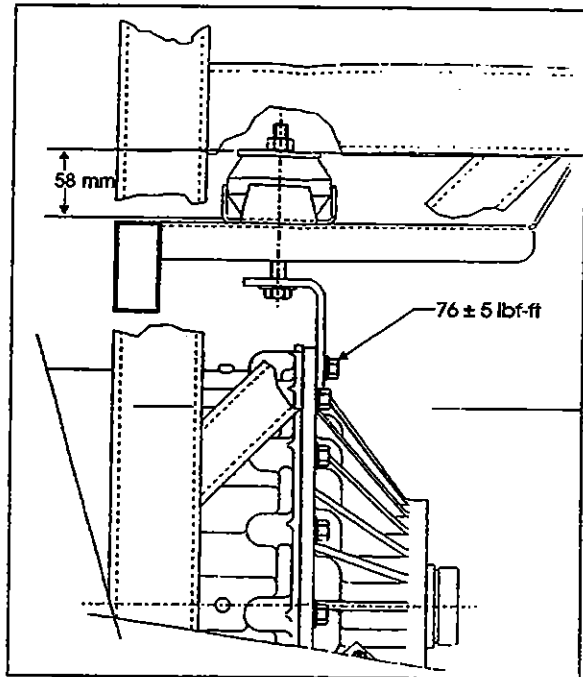

Figure 6: Nut Tolerance

07014

11. Remove jack from under transmission.
  12. Connect all sensors.
  13. Connect the main wiring harness.
- Note:** Refer to paragraph "4. Gear Shift Linkage" of this section for proper adjustment.
14. Connect the air supply line (steel-braided hose) to the retarder control valve (if applicable).
  15. Connect the two transmission oil cooler hoses as they were previously.
  16. Reinstall clamps and brackets, and replace locking ties that had been removed during removal procedure.
  17. Install propeller shaft and its safety guard. Refer to Section 09, "Propeller Shaft".
  18. Install transmission dipstick and filler tube.
  19. Install cross member under transmission.

## Section 07: TRANSMISSION

20. Install engine splash guards.
21. Adjust the retarder pressure to  $80 \pm 3$  psi with the air pressure regulator. For more information refer to Section 12, "Brake and Air System", under heading "Air Pressure Regulator". The air pressure regulator is located in engine compartment R.H. side (Fig. 7).



Figure 7: Air Pressure Regulator

02003

22. Make sure that the drain plug is in place, then remove the transmission dipstick and pour approximately 37 US qts (39 L) of DEXRON-IIIE or DEXRON-III automatic transmission fluid through the filler tube. Check and adjust oil level.

**Caution:** Do not overfill the transmission. Overfilling can cause oil aeration (milky appearance) and overheating. If overfilling occurs, drain oil as required to bring it to the proper level.

## 8.2 Manual Transmission

**Note:** For more clearance between the tag axle and transmission, the tag axle may be unloaded and jacked up or retracted (if applicable).

1. Place the transmission on a transmission jack.

2. Ensure clutch brake is in position on transmission input shaft.
3. Position the clutch release bearing with the flat section on top.
4. Shift transmission into 5th gear, then raise it and position the input shaft into clutch discs. Align input shaft splines with those on clutch discs by rotating the output shaft. As the input shaft enters the clutch discs, rotate the clutch release yoke backwards until the release yoke fingers clear the pads on release bearing housing. Rotate the clutch release yoke into proper position as transmission is pushed into place.

**Caution:** Avoid hanging the weight of the transmission on the clutch or forcing the transmission into the clutch or flywheel housing. This can cause bent or sprung clutch discs and prevent the clutch from releasing.

**Caution:** The clutch housing must be seated against the flywheel housing prior to tightening any screw. Do not use screws to seat the housing.

5. Install in all clutch/engine screws, then tighten them gradually and in a criss-cross manner around the housing. Tighten the remaining screws. Recommended torque is 44-50 lbf•ft (60-68 N•m).
6. Remove jack from under transmission.
7. Install clutch slave cylinder and its return spring.

**Note:** Refer to Section 02, "Clutch" for adjustment.

8. Connect speedometer sensor, back-up signal switch and neutral start switch.

9. Reinstall clamps, brackets, and replace locking ties that had been removed during removal procedure.
10. Shift transmission to neutral, then secure the coupling lever bolts.

**Note:** Refer to paragraph "4. Gear Shift Linkage" of this section, for proper adjustment.

11. Install fiberglass transmission protection.
12. Install propeller shaft and its safety guard. Refer to Section 09, "Propeller Shaft".
13. Install cross member under transmission.
14. Install engine splash guards.
15. Install tag axle wheels.
16. Make sure that the drain plug is in place, then refill transmission. Check and adjust oil level.
17. Adjust the servo clutch pressure to 40 psi with the air pressure regulator. For more information, refer to Section 12, "Brake and Air System", under heading "Air Pressure Regulator". The air pressure is located in the engine compartment R.H. side (Fig. 7).

## 9. ALLISON TRANSMISSIONS PRINCIPLES OF OPERATION

Refer to "Allison Transmission, MD Series, Principles of Operation, SA 2454".

## 10. TROUBLESHOOTING

### 10.1 Manual Transmission

Refer to the Troubleshooting section in the Spicer Service Manual PS130-6B (6-speed) or PS145-7A (7-speed) depending upon the transmission installed on your vehicle. Manuals are annexed to the end of this section.

### 10.2 Automatic Transmission

Refer to "Allison Transmission, MD Series, Troubleshooting Manual, SA 2158A".

#### 10.2.1 Diagnostic Code Memory

Diagnostic codes are logged in a list in memory (sometimes referred to as the queue), positioning the most recently occurring code first and containing up to five codes. The codes contained in the list have the information recorded as shown in the chart below. Access to the code list position, main code, sub code and active indicator is available through either the shifter display or the Pro-Link Diagnostic Data Reader (DDR). Access to the ignition cycle counter and event counter is obtained through the DDR only.

**Section 07: TRANSMISSION**

Code List Position	Main Code	Sub Code	Active Indicator	Ignition Cycle Counter	Event Counter
d1	21	12	YES	00	10
d2	41	12	YES	00	04
d3	23	12	NO	08	02
d4	34	12	NO	13	01
d5	56	11	NO	22	02
Displayed on shifter display and DDR			YES= ACTIVE= "MODE ON"	Ignition cycle counter and event counter are not available on shifter display	

**Note:** All information is available with a diagnostic tool.

The following paragraphs define the different parts of the code list.

**Code List Position**

The position (1 through 5) which a code occupies in the code list in memory. Positions are shown as "d1" (Diagnostic Code #1) through "d5."

**Main Code**

The general condition or area of fault detected by ECU.

**Sub Code**

The specific area or condition under the main code in which the condition was detected.

**Active Indicator**

Will be turned "on" when a fault condition is active (shifter will display "MODE ON" or the DDR will display "YES"). Will be set to "Off" when conditions exist to indicate fault condition is gone.

**Ignition Cycle Counter**

Used to clear diagnostic codes that are inactive from the code list in memory. A counter is incremented each time a normal ECU power down occurs following clearing of the Active Indicator. A code will be cleared from the list when the counter exceeds 25.

**Event Counter**

Used to count the number of occurrences of a diagnostic code occurs prior to the incident being cleared from the code list. The most recent code will be in position "d1". If the most recent code is one which is already in the code list, that code will be moved to position "d1", the Active Indicator will be turned "on" (shifter will display "MODE ON" or the DDR will display "YES"), the Ignition Cycle Counter is cleared and "1" is added to the Event Counter.

## Clearing the Active Indicator and code Records from the Code List in Memory

If the conditions causing a diagnostic code to be set are cleared, the Active Indicator can be manually cleared by holding the "MODE" button down continuously for 3 seconds until a tone is heard from the shifter.

To clear code records from the list, hold the "MODE" button down continuously for ten seconds until a second tone sounds. All diagnostic records in the list that are not active will then be cleared and the remaining records will be moved up the list.

## Code Reading and Code Clearing Procedures

Diagnostic codes can be read and cleared by two methods: by using the Pro-Link 9000 DDR plugged in the receptacle located on L.H. lateral console or by using the shifter display. The use of the Pro-Link 9000 DDR is described in the instruction manual supplied with each tool. The method for reading and clearing codes described in this section refers only to entering of the Diagnostic Display Mode by the proper button selection.

The Diagnostic Display Mode may be entered for viewing of codes at any speed. Codes can only be cleared when the output speed = 0 and no output speed sensor failure is active.

The following descriptions explain how to use the shifter to read and clear codes.

### Reading Codes

1. Enter the diagnostic display mode by pressing the "↑" and "↓" (upshift and downshift arrows) buttons at the same time on the pushbutton shifter.

**Note:** If a "DO NOT SHIFT" condition is present at this time, the lever should be in the same position as it was at the time of code detection. If not, this shifter tone will sound continuously.

**Note:** If an oil level sensor is present, the oil level will be displayed first. Diagnostic code display is achieved by depressing the upshift and downshift arrows or display mode button a second time.

2. Read the first code in the first of five code positions on the digital display of the shifter. For example, we will read code every two seconds as follows:
  - a. Code list position --"d1";
  - b. Main code --"25";
  - c. Sub code --"11"; and
  - d. Display will repeat cycle of a., b. and c. above.
3. Press the "MODE" button momentarily to view the second position (d2) in the same way as 2. above.
4. To view the third, fourth and fifth positions (d3, d4 and d5), momentarily press the "MODE" button as explained above.
5. Pressing the "MODE" button momentarily after the fifth position is displayed will cause the sequence of code positions to start over with the first position.
6. Any code which is active will be indicated by the "MODE ON" indicator (active indicator) being turned on while in that code position (while in the normal operation).
7. Any code position in the list which does not have a diagnostic code logged will display "- -" for both the main and sub code displays. All positions after a code codes.

### Clearing Codes

1. Clearing of the active indicator is automatically done at ECU power down on all but code 69 34.
2. Some codes will clear the active indicator automatically when the condition causing the code is no longer detected by the ECU (see Diagnostic Code List and Description, page 19).

## Section 07: TRANSMISSION

3. Manual clearing is possible while in the diagnostic display mode and after the condition causing the code is corrected (output speed must be zero).
  - a. To clear all active indicators, hold the "MODE" button down continuously for 3 seconds until the shifter tone sounds for 0.5 seconds.
  - b. Release the "MODE" button to return to normal operating mode. If the condition causing the code was not active at the time, the active indicator will turn off.

**Caution:** *If clearing a code while locked in a Forward or Reverse position (fail-to-range), the transmission will still be in Drive or Reverse when the clearing procedure is completed. Neutral must be selected manually.*

### Exiting the Diagnostic Display Mode

The diagnostic display mode can be exited by any of the following procedures:

1. Press the "↑" and "↓" (upshift and downshift) buttons at the same time on the pushbutton shifter.
2. Press any range button, "D", "N" or "R", on the pushbutton shifter (the shift will be commanded if it is not inhibited by an active code).
3. Do nothing and wait until the calibrated time (approximately 10 minutes) has passed and the system automatically returns to the normal operating mode.
4. Turn off power to the ECU (turn off the vehicle at the ignition switch).
5. After the clearing of a code, the active indicator procedure described above has been performed.

### Clearing Records from the Code List in Memory

If the requirements for Manual Clearing the Active Indicator have been satisfied, and the "MODE" button is held down continuously for ten seconds while in the display mode until a tone sounds, all diagnostic records in the code list that are not

active will be cleared and the remaining records will be moved up in the code list.

## Abbreviations Found in the Code Chart

The following responses are used throughout the following chart to command safe operation when diagnostic codes are set.

1. **DNS (Do Not Shift) Response**
  - a. Turn off lockup clutch and inhibit lockup operation.
  - b. Inhibit all shifts.
  - c. Turn on *DO NOT SHIFT* light.
  - d. Pulse the tone generator for 8 seconds when the condition is first detected.
  - e. Blank the select digit in the display.
  - f. Ignore any range selection inputs and disable the button feedback tone for the pushbutton shifter.
2. **SOL OFF (Solenoid Off) Response**
  - a. All solenoids are commanded off (turning solenoids "A" and "B" off electrically causes them to be on hydraulically).
3. **RPR (Return to Previous Range) Response**
  - a. When the ratio or C3 pressure switch tests associated with a shift are not passed, the ECU commands the same range as commanded at the beginning of the shift.
4. **NNC (Neutral No Clutches) Response**
  - a. When certain ratio or C3 pressure switch tests are not passed, the ECU commands a neutral condition with no clutches applied.



## Diagnostic code list and description

MAIN CODE	SUB CODE	DESCRIPTION	DO NOT SHIFT LIGHT	INHIBITED OPERATION DESCRIPTION
12	12	Oil level, low	No	No upshift above a calibration range
12	23	Oil level, high	No	No upshift above a calibration range
13	12	ECU input voltage, low	Yes	DNS, SOL OFF (Hydraulic default)
13	13	ECU input voltage, medium low	No	None: Shift adaptive feature will not function.
13	23	ECU input voltage, high	Yes	DNS, SOL OFF (Hydraulic default)
14	12	Oil level sensor, low	No	None
14	23	Oil level sensor, high	No	None
21	12	Throttle position sensor, low	No	Use Throttle default value
21	23	Throttle position sensor, high	No	Use Throttle default value
22	14	Engine speed sensor reasonableness test	No	Use default engine speed
22	15	Turbine speed sensor reasonableness test	Yes	DNS, Lock in current range
22	16	Output speed sensor reasonableness or rapid decel test	Yes	DNS, Lock in current range
23	12	Primary Shifter or RSI Link Fault	No	Hold in last valid direction
23	13	Primary Shifter Mode Function Fault	No	Mode change not permitted
23	14	Secondary Shifter or RSI Link Fault	No	Hold in last valid direction
23	15	Secondary Shifter Mode Function Fault	No	Mode change not permitted
24	12	Sump oil temperature, cold	Yes	DNS
24	23	Sump oil temperature, hot	No	No upshifts above a calibration range
25	00	Output speed reasonableness test, detected at 0 speed, (L)	Yes	DNS, Lock in current range (L)

**Section 07: TRANSMISSION**

MAIN CODE	SUB CODE	DESCRIPTION	DO NOT SHIFT LIGHT	INHIBITED OPERATION DESCRIPTION
25	11	Output speed reasonableness test, detected at 0 speed, (1st)	Yes	DNS, Lock in current range (1 st)
25	22	Output speed reasonableness test, detected at 0 speed 2nd	Yes	DNS, Lock in current range (2nd)
25	33	Output speed reasonableness test, detected at 0 speed, 3rd	Yes	DNS, Lock in current range (3rd)
25	44	Output speed reasonableness test, detected at 0 speed, 4th	Yes	DNS, Lock in current range (4th)
25	55	Output speed reasonableness test, detected at 0 speed, 5th	Yes	DNS, Lock in current range (5th)
25	66	Output speed reasonableness test, detected at 0 speed, 6th	Yes	DNS, Lock in current range (6th)
25	77	Output speed reasonableness test, detected at 0 speed, R	Yes	DNS, Lock in current range (R)
32	00	C3 pressure switch open, L range	Yes	DNS, Lock in current range (L)
32	33	C3 pressure switch open, 3rd range	Yes	DNS, Lock in current range (3rd)
32	55	C3 pressure switch open, 5th range	Yes	DNS, Lock in current range (5th)
32	77	C3 pressure switch open, R range	Yes	DNS, Lock in current range (R)
33	12	Sump oil temperature sensor, low	No	Use default value of 200° F (93° C)
33	23	Sump oil temperature sensor, high	No	Use default value of 200° F (93° C)
34	12	EEPROM, factory cal. compatibility number wrong	Yes	DNS, SOL OFF (Hydraulic default)
34	13	EEPROM, factory calibration block checksum	Yes	DNS, SOL OFF (Hydraulic default)
34	14	EEPROM, Power Off Block checksum	Yes	Use previous location, or factory calibration and reset adaptive
34	15	EEPROM, Diagnostic Queue Block Checksum	Yes	Use previous location, or clear diagnostic queue

Section 07: TRANSMISSION

MAIN CODE	SUB CODE	DESCRIPTION	DO NOT SHIFT LIGHT	INHIBITED OPERATION DESCRIPTION
34	16	EEPROM, Real Time Block Checksum	Yes	DNS, SOL OFF (Hydraulic default)
35	00	Power interruption (Code set after power restored)	No	NONE (Hydraulic default during interruption)
35	16	Real Time EEPROM Write Interruption	Yes	DNS, SOL OFF (Hydraulic default)
36	00	Hardware/Software not compatible	Yes	DNS, SOL OFF (Hydraulic default)
41	12	Open or short to ground, A solenoid circuit	Yes	DNS, SOL OFF (Hydraulic default)
41	13	Open or short to ground, B solenoid circuit	Yes	DNS, SOL OFF (Hydraulic default)
41	14	Open or short to ground, C solenoid circuit	Yes	DNS, SOL OFF (Hydraulic default)
41	15	Open or short to ground, D solenoid circuit	Yes	DNS, SOL OFF (Hydraulic default)
41	16	Open or short to ground, E solenoid circuit	Yes	DNS, SOL OFF (Hydraulic default)
41	21	Open or short to ground, F solenoid circuit	No	Lock-up inhibited
41	22	Open or short to ground, G solenoid circuit	Yes	DNS, SOL OFF (Hydraulic default)
41	23	Open or short to ground, H solenoid circuit	No	Retarder allowed, differential lock inhibited
41	24	Open or short to ground, J solenoid circuit	No	Low and 1st inhibited
41	25	Open or short to ground, K solenoid circuit	No	K solenoid operation inhibited
41	26	Open or short to ground, N solenoid circuit	No	Low and 1st inhibited
42	12	Short to battery, A solenoid circuit	Yes	DNS, Lock in a range
42	13	Short to battery, B solenoid circuit	Yes	DNS, Lock in a range

**Section 07: TRANSMISSION**

MAIN CODE	SUB CODE	DESCRIPTION	DO NOT SHIFT LIGHT	INHIBITED OPERATION DESCRIPTION
42	14	Short to battery, C solenoid circuit	Yes	DNS, Lock in a range
42	15	Short to battery, D solenoid circuit	Yes	DNS, Lock in a range
42	16	Short to battery, E solenoid circuit	Yes	DNS, Lock in a range
42	21	Short to battery, F solenoid circuit	No	Lock-up inhibited
42	22	Short to battery, G solenoid circuit	Yes	DNS, Lock in a range
42	23	Short to battery, H solenoid circuit	No	Retarder allowed, differential lock inhibited
42	24	Short to battery, J solenoid circuit	No	Low and 1st inhibited
42	25	Short to battery, K solenoid circuit	No	K solenoid operation inhibited
42	26	Short to battery, N solenoid circuit	No	Low and 1st inhibited
43	21	Low side driver, F solenoid circuit	No	Lock-up inhibited
43	25	Low side driver, K solenoid circuit	No	K solenoid operation inhibited
43	26	Low side driver, N solenoid circuit	No	Low and 1st inhibited
44	12	Short to ground, A solenoid circuit	Yes	DNS, SOL OFF (Hydraulic default)
44	13	Short to ground, B solenoid circuit	Yes	DNS, SOL OFF (Hydraulic default)
44	14	Short to ground, C solenoid circuit	Yes	DNS, SOL OFF (Hydraulic default)
44	15	Short to ground, D solenoid circuit	Yes	DNS, SOL OFF (Hydraulic default)
44	16	Short to ground, E solenoid circuit	Yes	DNS, SOL OFF (Hydraulic default)
44	21	Short to ground, F	No	Lock-up inhibited

## Section 07: TRANSMISSION

MAIN CODE	SUB CODE	DESCRIPTION	DO NOT SHIFT LIGHT	INHIBITED OPERATION DESCRIPTION
		solenoid circuit		
44	22	Short to ground,G solenoid circuit	Yes	DNS, SOL OFF (Hydraulic default)
44	23	Short to ground,H solenoid circuit	No	Retarder allowed. differential lock inhibited
44	24	Short to ground,J solenoid circuit	No	Low and 1st inhibited
44	25	Short to ground,K solenoid circuit	No	K solenoid operation inhibited
44	26	Short to ground,N solenoid circuit	No	Low and 1st inhibited
45	12	Open circuit,A solenoid circuit	Yes	DNS, SOL OFF (Hydraulic default)
45	13	Open circuit,B solenoid circuit	Yes	DNS, SOL OFF (Hydraulic default)
45	14	Open circuit,C solenoid circuit	Yes	DNS, SOL OFF (Hydraulic default)
45	15	Open circuit,D solenoid circuit	Yes	DNS, SOL OFF (Hydraulic default)
45	16	Open circuit,E solenoid circuit	Yes	DNS, SOL OFF (Hydraulic default)
45	21	Open circuit,F solenoid circuit	No	Lock-up inhibited
45	22	Open circuit,G solenoid circuit	Yes	DNS, SOL OFF (Hydraulic default)
45	23	Open circuit,H solenoid circuit	No	Retarder allowed differential lock inhibited
45	24	Open circuit,J solenoid circuit	No	Low and 1st inhibited
45	25	Open circuit,K solenoid circuit	No	K solenoid operation inhibited
45	26	Open circuit,N solenoid circuit	No	Low and 1st inhibited
51	10	Offgoing ratio test (during shift), 1 to L	Yes	Low and 1st inhibited

**Section 07: TRANSMISSION**

MAIN CODE	SUB CODE	DESCRIPTION	DO NOT SHIFT LIGHT	INHIBITED OPERATION DESCRIPTION
51	12	Offgoing ratio test (during shift), 1 to 2	Yes	DNS, RPR
51	21	Offgoing ratio test (during shift), 2 to 1	Yes	DNS, RPR
51	23	Offgoing ratio test (during shift), 2 to 3	Yes	DNS, RPR
51	43	Offgoing ratio test (during shift), 4 to 3	Yes	DNS, RPR
51	45	Offgoing ratio test (during shift), 4 to 5	Yes	DNS, RPR
51	65	Offgoing ratio test (during shift), 6 to 5	Yes	DNS, RPR
52	01	Offgoing C3PS test (during shift), L to 1	Yes	DNS, RPR
52	08	Offgoing C3PS test (during shift), L to N1	Yes	DNS, NNC
52	32	Offgoing C3PS test (during shift), 3 to 2	Yes	DNS, RPR
52	34	Offgoing C3PS test (during shift), 3 to 4	Yes	DNS, RPR
52	54	Offgoing C3PS test (during shift), 5 to 4	Yes	DNS, RPR
52	56	Offgoing C3PS test (during shift), 5 to 6	Yes	DNS, RPR
52	71	Offgoing C3PS test (during shift), R to 1	Yes	DNS, NNC
52	72	Offgoing C3PS test (during shift), R to 2	Yes	DNS, NNC
52	78	Offgoing C3PS test (during shift), R to N1	Yes	DNS, NNC
52	79	Offgoing C3PS test (during shift), R to 2 (R to NNC to 2)	Yes	DNS, NNC
52	99	Offgoing C3PS test (during shift), N3 to N2	Yes	DNS, RPR
53	08	Offgoing speed test (during shift),	Yes	DNS, NNC

## Section 07: TRANSMISSION

MAIN CODE	SUB CODE	DESCRIPTION	DO NOT SHIFT LIGHT	INHIBITED OPERATION DESCRIPTION
		L to N1		
53	18	Offgoing speed test (during shift), 1 to N1	Yes	DNS, NNC
53	28	Offgoing speed test (during shift), 2 to N1	Yes	DNS, NNC
53	29	Offgoing speed test (during shift), 2 to N2	Yes	DNS, RPR
53	38	Offgoing speed test (during shift), 3 to N1	Yes	DNS, NNC
53	39	Offgoing speed test (during shift), 3 to N3	Yes	DNS, RPR
53	48	Offgoing speed test (during shift), 4 to N1	Yes	DNS, NNC
53	49	Offgoing speed test (during shift), 4 to N3	Yes	DNS, RPR
53	58	Offgoing speed test (during shift), 5 to N1	Yes	DNS, NNC
53	59	Offgoing speed test (during shift), 5 to N3	Yes	DNS, RPR
53	68	Offgoing speed test (during shift), 6 to N1	Yes	DNS, NNC
53	69	Offgoing speed test (during shift), 6 to N4	Yes	DNS, RPR
53	78	Offgoing speed test (during shift), R to N1	Yes	DNS, NNC
53	99	Offgoing speed test (during shift), N2 to N3 or N3 to N2	Yes	DNS, RPR
54	01	Oncoming ratio test (after shift), L to 1	Yes	DNS, RPR
54	07	Oncoming ratio test (after shift), L to R	Yes	DNS, NNC
54	10	Oncoming ratio test (after shift), 1 to L	Yes	DNS, RPR
54	12	Oncoming ratio test (after shift), 1 to 2	Yes	DNS, RPR

**Section 07: TRANSMISSION**

MAIN CODE	SUB CODE	DESCRIPTION	DO NOT SHIFT LIGHT	INHIBITED OPERATION DESCRIPTION
54	17	Oncoming ratio test (after shift), 1 to R	Yes	DNS, NNC
54	21	Oncoming ratio test (after shift), 2 to 1	Yes	DNS, RPR
54	23	Oncoming ratio test (after shift), 2 to 3	Yes	DNS, RPR
54	27	Oncoming ratio test (after shift), 2 to R	Yes	DNS, NNC
54	32	Oncoming ratio test (after shift), 3 to 2	Yes	DNS, RPR
54	34	Oncoming ratio test (after shift), 3 to 4	Yes	DNS, RPR
54	43	Oncoming ratio test (after shift), 4 to 3	Yes	DNS, RPR
54	45	Oncoming ratio test (after shift), 4 to 5	Yes	DNS, RPR or SOL OFF (Hydraulic default)
54	54	Oncoming ratio test (after shift), 5 to 4	Yes	DNS,RPR
54	56	Oncoming ratio test (after shift), 5 to 6	Yes	DNS,RPR
54	65	Oncoming ratio test (after shift), 6 to 5	Yes	DNS,RPR
54	70	Oncoming ratio test (after shift), R to L	Yes	DNS,NNC
54	71	Oncoming ratio test (after shift), R to 1	Yes	DNS,NNC
54	72	Oncoming ratio test (after shift), R to 2	Yes	DNS,NNC
54	80	Oncoming ratio test (after shift), N1 to L	Yes	DNS,RPR
54	81	Oncoming ratio test (after shift), N1 to 1	Yes	DNS,RPR
54	82	Oncoming ratio test (after shift), N1 to 2	Yes	DNS,RPR
54	83	Oncoming ratio test (after shift),	Yes	DNS,RPR



## Section 07: TRANSMISSION

MAIN CODE	SUB CODE	DESCRIPTION	DO NOT SHIFT LIGHT	INHIBITED OPERATION DESCRIPTION
		N1 to 3		
54	85	Oncoming ratio test (after shift), N1 to 5	Yes	DNS,RPR
54	86	Oncoming ratio test (after shift), N1 to 6	Yes	DNS, RPR
54	92	Oncoming ratio test (after shift), R to 2 (R to NNC to 2)	Yes	DNS, NNC
54	92	Oncoming ratio test (after shift), N1 to 2 (N1 to NNC to 2)	Yes	DNS, RPR
54	92	Oncoming ratio test (after shift), N2 to 2	Yes	DNS, RPR
54	93	Oncoming ratio test (after shift), N3 to 3	Yes	DNS, RPR
54	95	Oncoming ratio test (after shift), N3 to 5	Yes	DNS, RPR
54	96	Oncoming ratio test (after shift), N4 to 6	Yes	DNS, RPR
54	97	Oncoming ratio test (after shift), 2 to R (2 to NNC to R)	Yes	DNS, NNC
55	17	Oncoming C3PS test (after shift), 1 to R	Yes	DNS, NNC
55	27	Oncoming C3PS test (after shift), 2 to R	Yes	DNS, NNC
55	80	Oncoming C3PS test (after shift), N1 to L	Yes	DNS, RPR
55	87	Oncoming C3PS test (after shift), N1 to R	Yes	DNS, RPR
55	97	Oncoming C3PS test (after shift), 2 to R or NVL to R (2 to NNC to R)	Yes	DNS, NNC
56	00	Range verification test, L	Yes	DNS, 1st, Low, or SOL OFF (Low)
56	11	Range verification test, 1st	Yes	DNS, 6th
56	22	Range verification test, 2nd	Yes	DNS, 6th or 5th
56	33	Range verification test, 3rd	Yes	DNS, 5th or SOL

**Section 07: TRANSMISSION**

MAIN CODE	SUB CODE	DESCRIPTION	DO NOT SHIFT LIGHT	INHIBITED OPERATION DESCRIPTION
56	44	Range verification test, 4th	Yes	DNS, 3rd or 5th
56	55	Range verification test, 5th	Yes	DNS, SOL OFF (5th) or 3rd
56	66	Range verification test, 6th	Yes	DNS, 5th, 3rd, or SOL OFF (3rd)
56	77	Range verification test, R	Yes	DNS, N2 or N3
57	11	Range verification C3PS test, 1st	Yes	DNS, SOL OFF (3rd)
57	22	Range verification C3PS test, 2nd	Yes	DNS, 3rd
57	44	Range verification C3PS test, 4th	Yes	DNS, 5th or SOL OFF (3rd)
57	66	Range verification C3PS test, 6th	Yes	SOL OFF (5th), DNS
57	88	Range verification C3PS test, N1	Yes	DNS, N3
57	99	Range verification C3PS test, N2 or N4	Yes	DNS, N3
61	00	Retarder oil temperature, hot	No	None
62	12	Retarder oil temperature sensor, low	No	None
62	23	Retarder oil temperature sensor, high	No	None
63	00	Special function input	No	Depends on special function
64	12	Retarder modulation request sensor, low	No	Retarder operation inhibited
64	23	Retarder modulation request sensor, high	No	Retarder operation inhibited
65	00	Engine rating too high	Yes	DNS
66	00	Serial communications interface fault	No	Use default throttle values
69	12	ECU, A solenoid driver open	Yes	DNS, SOL OFF (hydraulic default)
69	13	ECU, B solenoid driver open	Yes	DNS, SOL OFF (hydraulic default)
69	14	ECU, C solenoid driver open	Yes	DNS, SOL OFF (hydraulic default)
69	15	ECU, D solenoid driver open	Yes	DNS, SOL OFF (hydraulic default)
69	16	ECU, E solenoid driver open	Yes	DNS, SOL OFF

## Section 07: TRANSMISSION

MAIN CODE	SUB CODE	DESCRIPTION	DO NOT SHIFT LIGHT	INHIBITED OPERATION DESCRIPTION
				(hydraulic default)
69	21	ECU, F solenoid driver open	No	Lock-up inhibited
69	22	ECU, G solenoid driver open	Yes	DNS, SOL OFF (Hydraulic default)
69	23	ECU, H solenoid driver open	No	Retarder allowed, differential lock inhibited
69	24	ECU, J solenoid driver open	No	Low and 1 st inhibited
69	25	ECU, K solenoid driver open	No	K solenoid operation inhibited
69	26	ECU, N solenoid driver open	No	Low and 1st inhibited
69	32	ECU, SPI communications link fault	No	Hold in last valid direction
69	33	ECU, Central Operating Processor (COP) timeout	Yes	Reset ECU, Shutdown ECU on 2nd occurrence (power loss: hydraulic defaults)
69	34	ECU, EEPROM write timeout	Yes	DNS, SOL OFF (Hydraulic default)
69	35	ECU, EEPROM checksum	Yes	Induce COP timeout (reset ECU)
69	36	ECU, RAM self test	Yes	Induce COP timeout (reset ECU)
69	41	ECU, I/O ASIC addressing test	Yes	Induce COP timeout (reset ECU)
70	35	Software, minor loop overrun	Yes	Induce COP timeout (reset ECU)
70	35	Software, illegal write to access \$0000	Yes	Induce COP timeout (reset ECU)
70	35	Software, major loop overrun	Yes	Induce COP timeout (reset ECU)

## 11. SPECIFICATIONS

### AUTOMATIC TRANSMISSION WITH OR WITHOUT RETARDER

Gross input power (maximum)..... 450 hp (335 kW)  
Gross input torque (maximum) ..... 1460 lbf·ft (1978 N·m)  
Rated input speed (minimum-maximum)..... 1600-2300 rpm

#### Mounting

Engine.....SAE #1 flywheel housing, flex disk drive

#### Torque converter

Type..... One stage, three element, polyphase  
Stall torque ratio..... TC 521-2.4;TC 531-2.3;TC 541-1.9;TC 551-1.8;TC 561-1.6  
Lockup clutch with torsional damper..... Integral/standard

#### Gearing

Type..... Patented, constant mesh, helical, planetary

	Ratio*
First.....	3.51:1
Second.....	1.91:1
Third.....	1.43:1
Fourth.....	1.00:1
Fifth.....	0.74:1
Sixth.....	0.64:1
Reverse.....	4.80:1

#### Ratio coverage

6 speed..... 5.48:1

\* Gear ratios do not include torque converter multiplication.

#### Oil System

Oil type..... DEXRON-IIIE OR DEXRON III  
Capacity (excluding external circuits) ..... Initial fill 47 US qts (45 liters)  
Oil change..... 37 US qts (39 liters)

#### Oil Filters

Make.....Allison Transmission  
Type..... Disposable cartridge  
Supplier number ..... 29503829  
Prévost number..... 57-1687

**MANUAL TRANSMISSION**

**SIX-SPEED**

Make ..... Spicer  
Model ..... PS130-6B

Ratio:  
LO 8.53:1  
1st 4.87:1  
2nd 3.00:1  
3rd 1.90:1  
4th 1.33:1  
5th 1.00:1  
Rev 8.53:1

Fluid:  
Type ..... Same as engine oil  
Capacity ..... 41 Pints (19.4 liters) at 0° Installation  
Torque Capacity ..... 1300 lbf·ft (1761 N·m)

**SEVEN-SPEED**

Make ..... Spicer  
Model ..... PS145-7A

Ratio:  
LO 10.13:1  
1st 5.99:1  
2nd 3.56:1  
3rd 2.57:1  
4th 1.84:1  
5th 1.33:1  
6th 1.00:1  
Rev 10.13:1

Fluid:  
Type ..... Same as engine oil  
Capacity ..... 48 Pints (22.7 liters) at 0° Installation  
Torque Capacity ..... 1450 lbf·ft (1964 N·m)

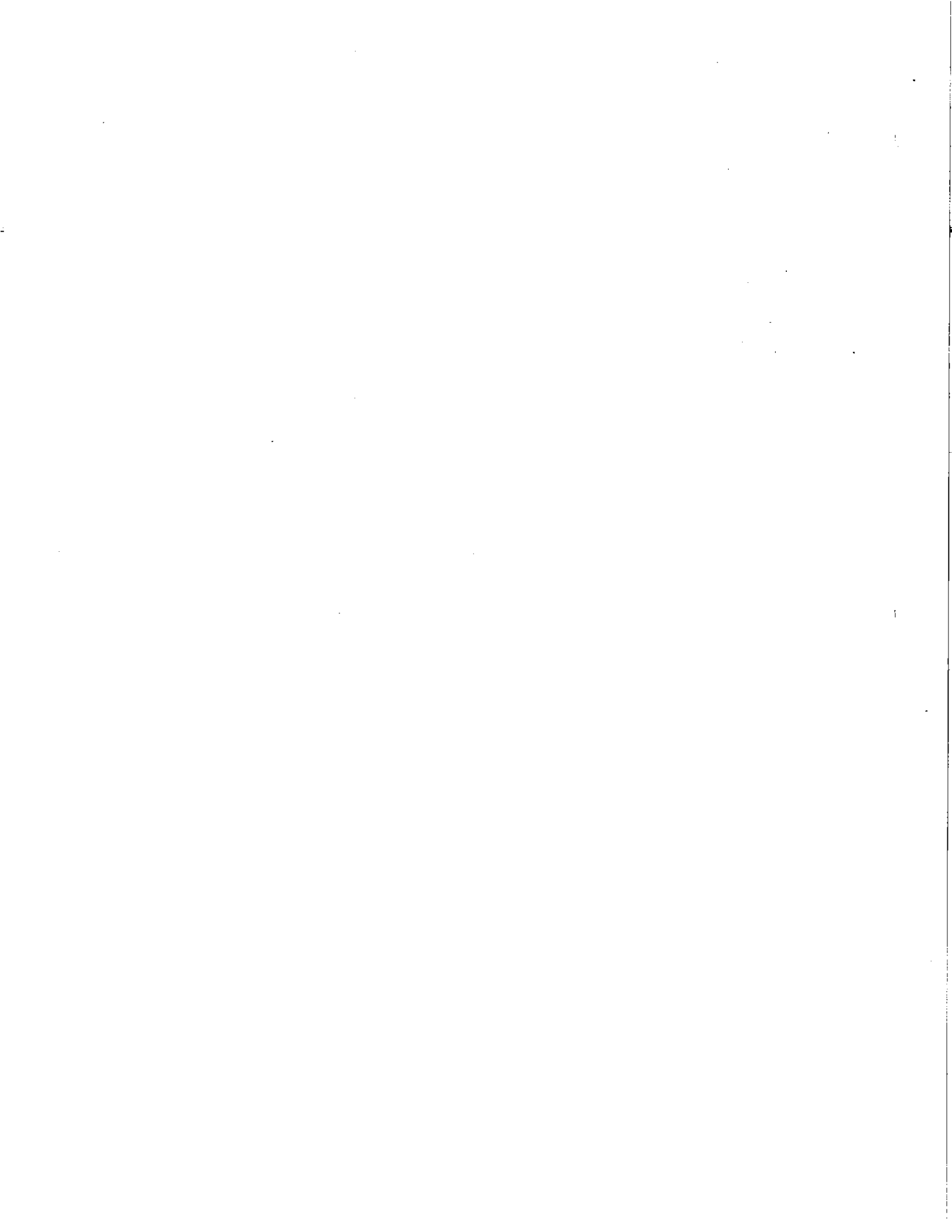



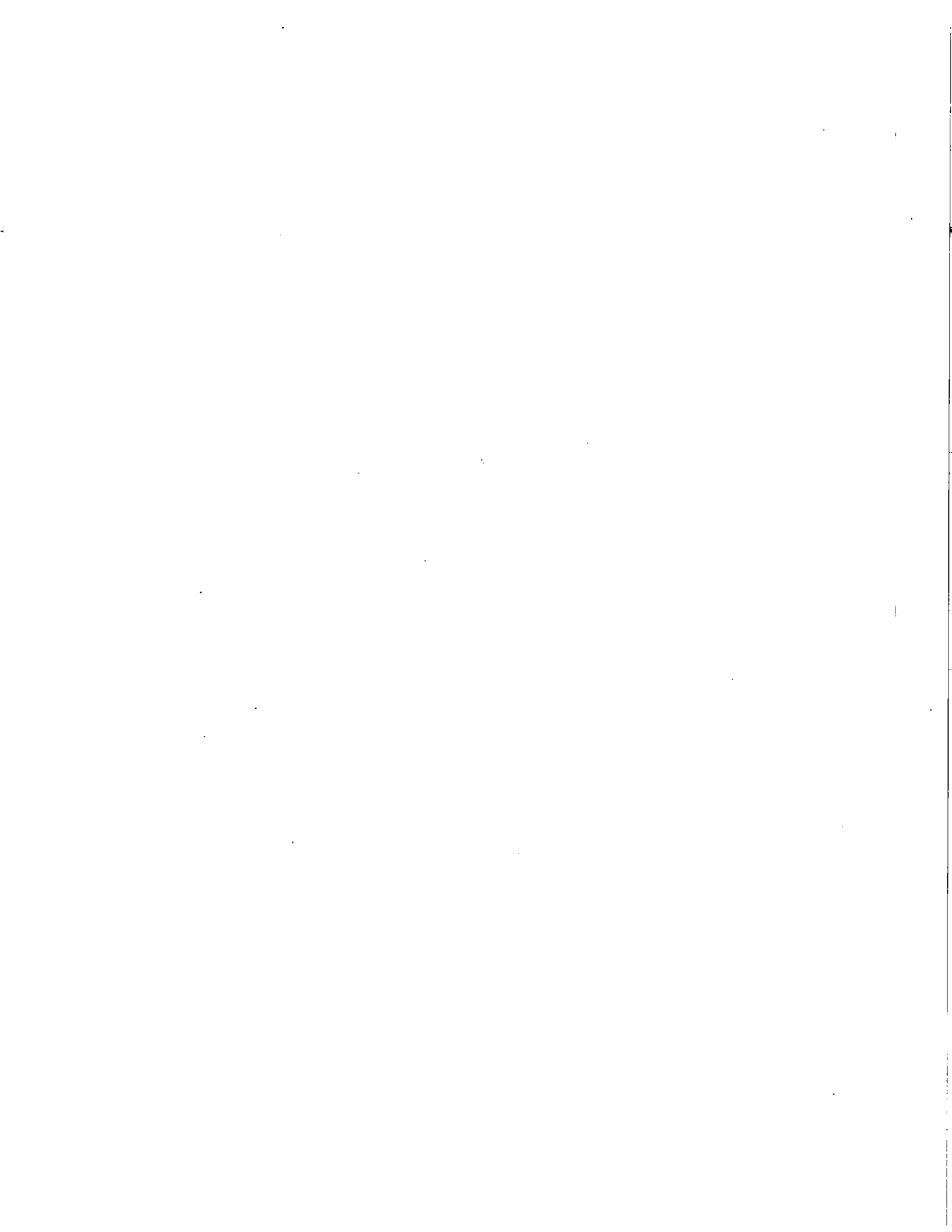



# SECTION 09: PROPELLER SHAFT

---

## CONTENTS

1. PROPELLER SHAFT.....	2
1.1 Description.....	2
2. REMOVAL, DISASSEMBLY, REASSEMBLY AND INSTALLATION .....	2
3. CLEANING, INSPECTION AND LUBRICATION.....	2
3.1 Cleaning and Inspection .....	2
3.2 Lubrication .....	2
4. EXPLANATION OF COMMON DAMAGES.....	3
5. TROUBLESHOOTING.....	3
6. SPECIFICATIONS .....	4

## 1. PROPELLER SHAFT

### 1.1 Description

The propeller shaft transmits power from the transmission to the differential (refer to Fig. 1). According to the transmission model with series 60 engine, two lengths of propeller shafts are available. Refer to paragraph "6. Specifications" at the end of this section for details. Both propeller shafts are "Dana 1810 " type and each shaft is tubular. They are provided with two heavy-duty universal joints (Fig. 1).

The propeller shaft has a full round end yoke at each end. The tube yoke is connected to the differential by a full round end yoke with four needle bearings.

The other extremity (slip yoke assembly) is connected to the transmission by a half round end yoke with two needle bearings.

Furthermore, a slip joint on the propeller shaft compensates for variations in distance between the transmission (manual or automatic) and the differential, or between the output retarder (optional on the automatic transmission) and differential.

These variations are brought about by the rise and fall of the drive axle as the vehicle passes over uneven surfaces. The slip joint also eases removal of the transmission or the drive axle.

## 2. REMOVAL, DISASSEMBLY, REASSEMBLY AND INSTALLATION

Refer to the "Spicer Universal Joint and Driveshafts" annexed to the end of this section, under headings Heavy Duty - Removal, Disassembly, Reassembly and Installation.

Where applicable:

- Remove or install propeller shaft safety guard.
- Screw bolts to the specified torque ( Fig. 1).

**Note:** *Disregard the procedure on lock straps mentioned in the Spicer Universal Joints and Driveshafts Manual.*

## 3. CLEANING, INSPECTION AND LUBRICATION

### 3.1 Cleaning and Inspection

Thoroughly clean grease from bearings, journal, lubricating grease fittings and other parts. Needle bearing assemblies may be soaked in a cleaning solution to soften hard grease particles. It is extremely important that bearing assemblies be absolutely clean and blown out with compressed air, since small particles of dirt or grit can cause rapid bearing wear. Do not attempt to disassemble needle bearings.

Bearing journal areas should be inspected for roughness or grooving. If light honing does not remove roughness, the entire bearing assembly should be replaced. Excessive wear of the needle bearing is indicated if the needles drop out of the retainer, or if marks are present on the journal bearing surface. In such case, replace bearing assembly. Finally, inspect yokes for cracks, wear or distortion.

**Note:** *Repair kits are available for overhaul of the propeller shaft assembly. Refer to the paragraph "6. Specifications" of this section.*

### 3.2 Lubrication

Lubricate propeller shaft universal joints and slip yoke periodically, every 6,250 miles (10 000 km) or twice a year, whichever comes first. Apply grease gun pressure to the lube fitting. Use a good quality lithium-base grease such as: NLGI No.2 (suitable for most temperatures) or NLGI No.1 (suitable for extremely low temperatures). Refer to "Spicer Universal Joints and Driveshafts, Service Manual", under heading, "Inspection and Lubrication". See lubrication procedures for U-joints and lubrication for slip splines.

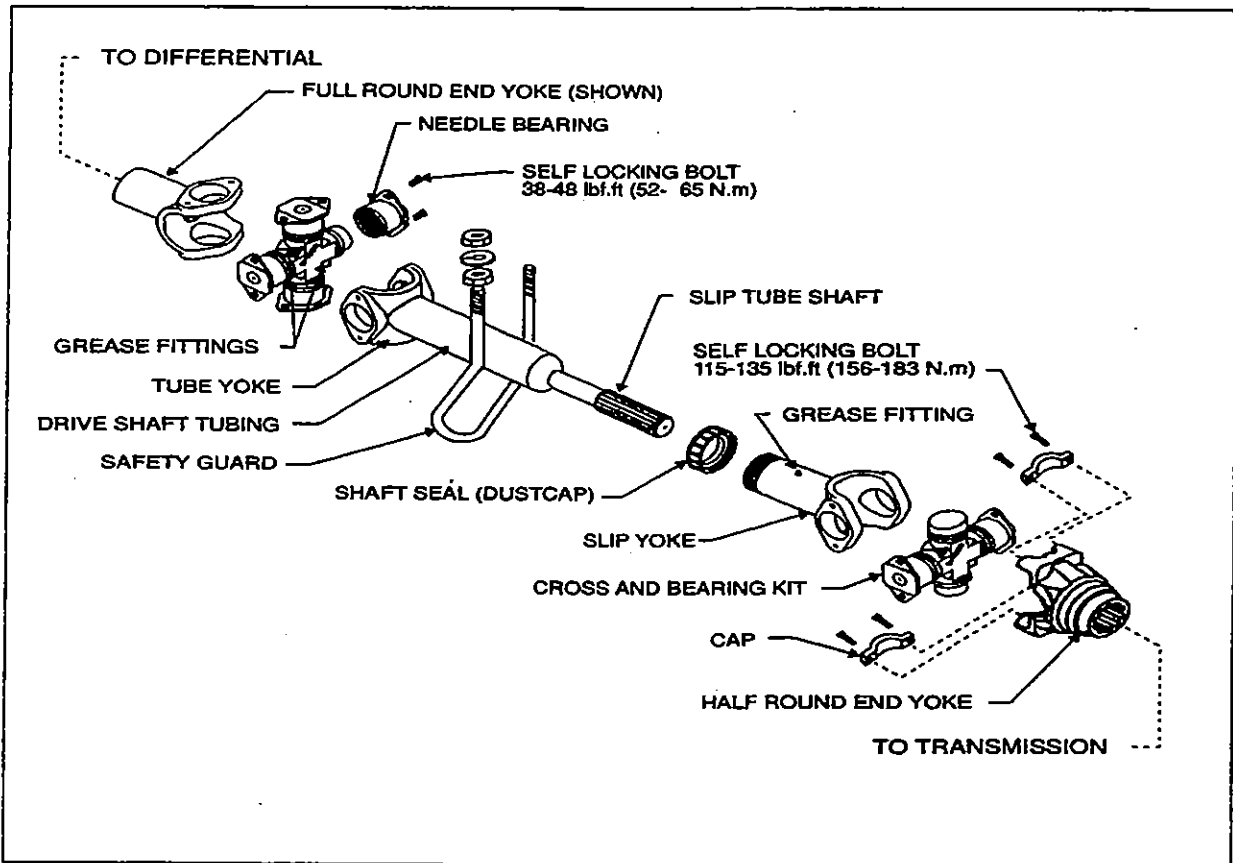

Figure 1: Propeller Shaft Assembly

09001

#### 4. EXPLANATION OF COMMON DAMAGES

1. **Cracks:** Stress lines due to metal fatigue. Severe and numerous cracks will weaken the metal until it breaks.
2. **Galling:** Scraping off of metal or metal displacement due to friction between surfaces. This is commonly found on trunnion ends.
3. **Spalling (surface fatigue):** Breaking off of chips, scales, or flakes of metal due to fatigue rather than wear. It is usually found on splines and U-joint bearings.
4. **Pitting:** Small pits or craters in metal surfaces due to corrosion. If excessive, pitting can lead to surface wear and eventual failure.
5. **Brinelling:** Surface wear failure due to the wearing of grooves in metal. It is often caused by improper installation procedures. Do not confuse the polishing of a surface (false brinelling), where no structural damage occurs, with actual brinelling.
6. **Structural Overloading:** Failure caused by a load greater than the component can stand. A structural overload may cause propeller shaft tubing to twist under strain or it may cause cracks or breaks in U-joints and spline plugs.

#### 5. TROUBLESHOOTING

Refer to "Spicer Universal Joints and Driveshafts, Service Manual". See heading "Troubleshooting".

## 6. SPECIFICATIONS

### PROPELLER SHAFT

#### For H3 Vehicles Equipped with a 6-Speed Manual Transmission

Make ..... Hayes-Dana Inc.  
Series ..... 1810  
Supplier number ..... 819325-2200  
Prevost number ..... 08-0072

#### For H3 Vehicles Equipped with an Automatic World Transmission or a 7-Speed Manual Transmission

Make ..... Hayes-Dana Inc.  
Series ..... 1810  
Supplier number ..... 819325-1900  
Prevost number ..... 08-0068

#### Repair kits

Make ..... Hayes-Dana Inc  
U-joint kit (tube yoke), Supplier number ..... 5-281X  
U-joint kit (tube yoke), Prevost number ..... 58-0043  
U-joint kit (slip yoke), Supplier number ..... 5-510X  
U-joint kit (slip yoke), Prevost number ..... 58-0062  
Cap and bolt kit, bolt torque 115-135 lbf·ft (156-183 N·m), Supplier number ..... 6.5-70-18X  
Cap and bolt kit, bolt torque 115-135 lbf·ft (156-183 N·m), Prevost number ..... 58-0063  
Bolts kit, bolt torque 38-48 lbf·ft (52-65 N·m), Supplier number ..... 6-73-209  
Bolts kit, bolt torque 38-48 lbf·ft (52-65 N·m), Prevost number ..... 58-0071

#### Half Round End Yoke

Make ..... Hayes-Dana Inc  
(6-speed), Supplier number ..... 6.5-4-3021-1  
(6-speed), Prevost number ..... 58-0072  
Make ..... Dana-Spicer  
(7-speed), Supplier number ..... 6.5-4-3821-1  
(7-speed), Prevost number ..... 57-1690

**Note:** U-joint kits will come equipped with the serrated bolt and lock patch and will no longer contain a lock strap.



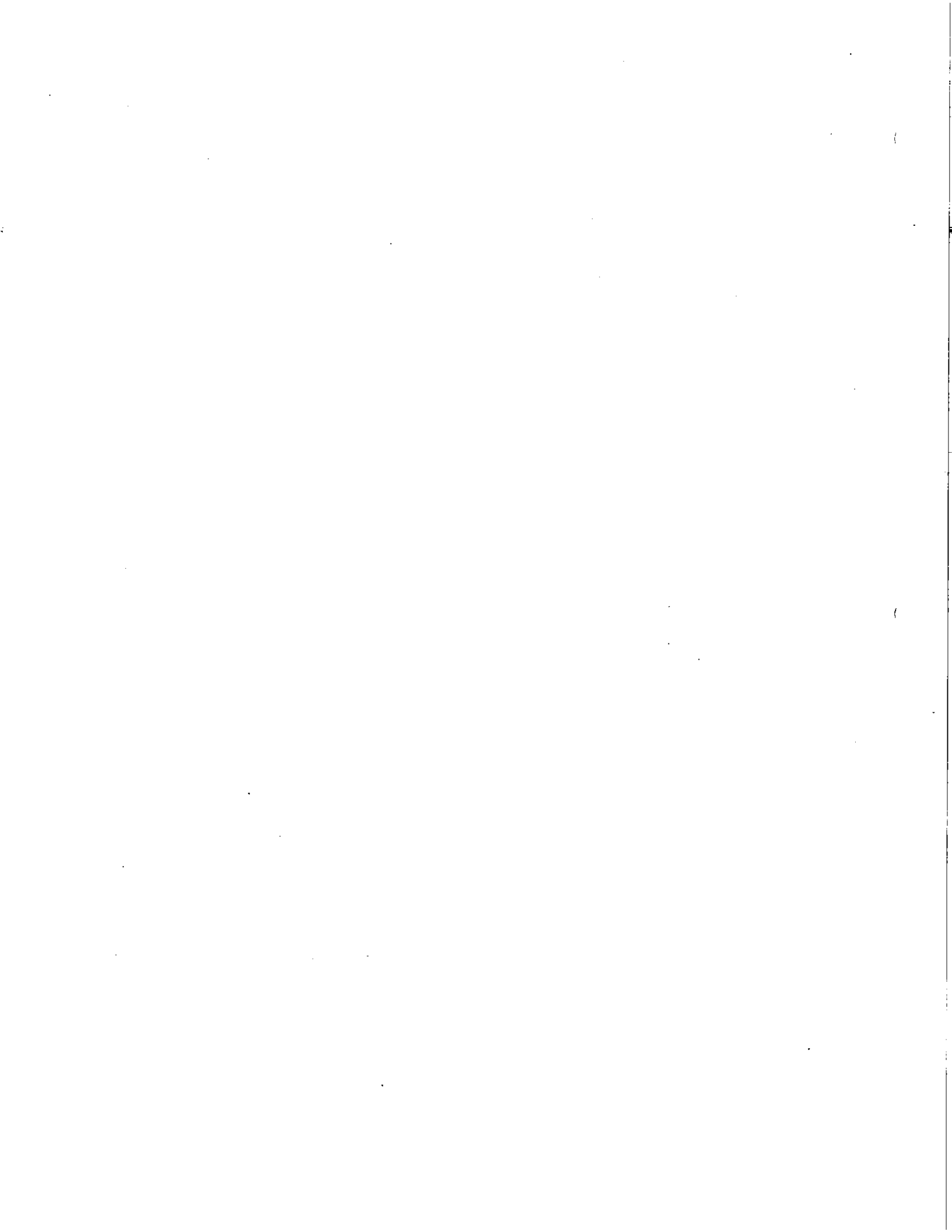

**HAYES-DANA PARTS COMPANY LTD**  
**HEAVY DUTY PRODUCTS DIVISION**  
South Service Rd., Beamsville, Ontario, L0R 1B0  
BRANCHES: Burnaby, Edmonton, Calgary, Winnipeg, Toronto

# SPICER®

## UNIVERSAL JOINTS

industrial / marine / automotive / construction



# Basic Torque Ratings

On the opposite page, a basic torque rating chart will provide ready reference for the complete universal joint series from light duty to extra heavy duty classification.

The ratings are divided into the respective joint duty sizes and are based on the following:

\*Electric Motor . . . continuous running rating based on minimum bearing life expectancy of 3000 hrs. operating at 3° Joint Angle @ 1750 r.p.m.

\*Gas or Diesel Engines . . . continuous running rating based on minimum bearing life expectancy of 5000 hrs. operating at 3° Joint Angle @ 3000 r.p.m.

Short Duration . . . represents the joints' capability to withstand momentary loading accompanying start-stop service.

Torsional Strength (minimum elastic limit) . . . represents the maximum torque load the universal joint will transmit instantaneously without brinelling bearing or yield in any part. This may be assumed to be the maximum safe shock load.

Maximum Operating Speed . . . is based on suitable proportions of length and tube diameter. For speeds below 100 RPM and above 6000 RPM contact Spicer Universal Joint Division, Engineering Department.

# Vehicle Applications

The truck application chart illustrated below will provide quick reference for universal joint application as

classified by vehicle duty from light to extra heavy service.

Spicer U-Joint Series		1280	1310	1330	1350	1410	1480	1550	1650/1650	1710	1810	1880	1950	2050	2150	
MAXIMUM GVW		6000	10000	13000	16000	22000	Over 22000									
MAXIMUM TORQUE RATING (Ft. Lbs.)	WHEEL SLIP (Lb. Ft.)	750	1050	1200												
	SLOW GEAR RATIO	8.5 to 1		1200	1400	1600	2100	2600	3800	5100	6800	9300	18400	36000	72000	
		21 to 1			1610	1840	2300	3000	4400	5850	7800	10700	21200	41500	83000	
		16 to 1			2100	2400	3000	3900	5700	7650	10200	14000	27600	54000	108000	

The Torque Ratings and Gross Vehicle Weights for the respective joint sizes are based on the following:

Light Duty Vehicles . . . 4,000 to 10,000 lbs. GVW . . . joint size is determined by Wheel Slip Torque. Generally, the effective torque transmitted to the axle is limited by the weight of the vehicle and represented by Wheel Slip Torque. Use 0.67 to 0.8 coefficient of friction depending on application.

$$\frac{RAL \times CF \times TRR}{AR} = \text{Drive Line Torque to Slip Wheels (In. Lbs.)}$$

Medium Duty Vehicles . . . 10,000 to 22,000 lbs. GVW generally do not develop sufficient torque to slip the wheels. Required joint size is determined by the Engine Torque x Low Gear Ratio. To compensate for

power losses, this ratio should be multiplied by 0.85 for Mechanical Transmissions, and 0.72 for Hydraulic Transmissions (Stall Torque).

Heavy Duty Vehicles . . . over 22,000 lbs. GVW based on the same factors as Medium Duty Vehicles, except as gear ratios are increased above 8.5 to 1, torque ratings are increased to allow for the lower percentage of time the vehicle uses low gear. To compute Low Gear Torque:  $ET \times TL \times 0.85 = LGT$  (Ft. Lbs.)

In applications using Auxiliary Transmissions or Transfer Cases in conjunction with the Main Transmission, Low Gear Torque is computed as follows:

$$\text{Auxiliary Transmission: } LGT \times AL \times 0.85 = ALGT \text{ (Ft. Lbs.)}$$

$$\text{Transfer Case: } LGT \times TCL \times 0.85 = CLGT \text{ (Ft. Lbs.)}$$

AL: Auxiliary Low Gear Ratio  
 ALGT: Auxiliary Low Gear Torque.  
 AR: Axle Ratio  
 CF: Coefficient of Friction  
 CLGT: (Transfer) Case Low Gear Torque  
 ET: Engine Torque

LGT: Low Gear Torque  
 RAL: Rear Axle Load  
 TCL: Transfer Case Low Gear Ratio  
 TL: (Main) Transmission Low Gear Ratio  
 TRR: (Driving) Tire Rolling Radius (Inches)  
 WST: Wheel Slip Torque

\*Applies to those universal joint sizes that have speed capability indicated.



# Universal Joint Sizes / Ratings / Speeds / Tube Sizes

SPICER U-JOINT SIZES	Electric Motor Torque			Gas or Diesel Torque		Short Duration Torque		Torsional Strength Min. Elastic Limit		Max. r.p.m.	Standard Tube Size	**Max. Length Installed @ Max. Rated r.p.m.
	H.P. per 100 r.p.m.	Lb. In.	Lb. Ft.	Lb. In.	Lb. Ft.	Lb. In.	Lb. Ft.	Lb. In.	Lb. Ft.			
<b>Light Duty</b>												
1000	1.42	900	75	600	50	3,720	310	5,040	420	2,500	1½" x .065	55"
1210	1.81	1,140	95	780	65	5,040	420	10,200	850	6,000	2½" x .065	43"
● 1280	2.66	1,680	140	1,140	95	6,840	570	15,000	1,250	6,000	2½" x .083	43"
1310	3.71	2,340	195	1,560	130	9,600	800	19,200	1,600	6,000	3" x .083	47"
1330	4.18	2,640	220	1,800	150	10,680	890	22,200	1,850	5,000	3½" x .083	50.5"
											4" x .083	54"
<b>Medium Duty</b>												
1350	5.90	3,720	310	2,520	210	14,880	1,240	27,120	2,260	5,000	3" x .083 3½" x .083 4" x .083	51" 55" 59"
● 1410	7.14	4,500	375	3,000	250	18,000	1,500	32,400	2,700	5,000	3" x .083 3½" x .083 4" x .083	51" 55" 59"
● 1480	9.52	6,000	500	4,080	340	24,000	2,000	39,960	3,330	5,000	3½" x .083 4" x .083 4½" x .095	55" 59" 63"
<b>Heavy Duty</b>												
● 1550	12.18	7,680	640	5,160	430	28,800	2,400	52,800	4,400	5,000	3½" x .095 4" x .083 4½" x .095	55" 59" 63"
● 1650	18.13	11,424	952	7,620	635	43,680	3,640	75,900	6,400	4,000	3½" x .134 4" x .134 4½" x .095	61" 66" 70"
1610	18.56	11,700	975	7,680	640	43,800	3,650	78,000	6,500	4,500	3½" x .134 4" x .134 4½" x .095	58" 62" 66"
1710	25.33	15,960	1,330	10,800	900	57,600	4,800	96,000	8,000	4,500	4" x .134 4½" x .134	62" 66"
● 1810	35.23	22,200	1,850	15,000	1,250	78,000	6,500	144,000	12,000	4,500	4½" x .134 4½" x .259	66" 65"
● 1980	48.55	30,600	2,550	20,400	1,700	106,800	8,900	192,000	16,000	3,000	4½" x .259	80"
<b>Extra Heavy Duty</b>												
● 1910	68.55	43,200	3,600	28,800	2,400	144,000	12,000	249,600	20,800	2,500	4½" x .250	80"
1950	102.82	64,800	5,400	43,200	3,600	216,000	18,000	408,000	34,000	2,500	5½" x .375	80"
2050	218.96	138,000	11,500	90,000	7,500	432,000	36,000	816,000	68,000	2,000	8" x .375	80"
2150	428.40	270,000	22,500	180,000	15,000	864,000	72,000	1,632,000	136,000	1,500	9" x .625	80"

\*Rating applies to Universal Joint.

\*\*Lengths shown with exception of 1900 thru 2150 sizes are based on .66 of the calculated critical speed at max. rated RPM (as applied to industrial applications). For vehicle applications or driveshaft assembly lengths exceeding 80 inches, consult Spicer Universal Joint Division, Application Engineering with complete design requirements.

●Wing bearings for use in the outboard position available in these sizes. See Bulletin #3226 for additional information.

## Operating Angles<sup>†</sup> For Two Joint Shafts with Equal Or Intersecting Angles

Driveshaft RPM	Maximum Operating Angle	Driveshaft RPM	Maximum Operating Angle
5000.....	3° 15'	3000.....	5° 50'
4500.....	3° 40'	2500.....	7° 0'
4000.....	4° 15'	2000.....	8° 40'
3500.....	5° 0'	1500.....	11° 30'

†Based on application experience (1000 rad/sec<sup>2</sup> acceleration).

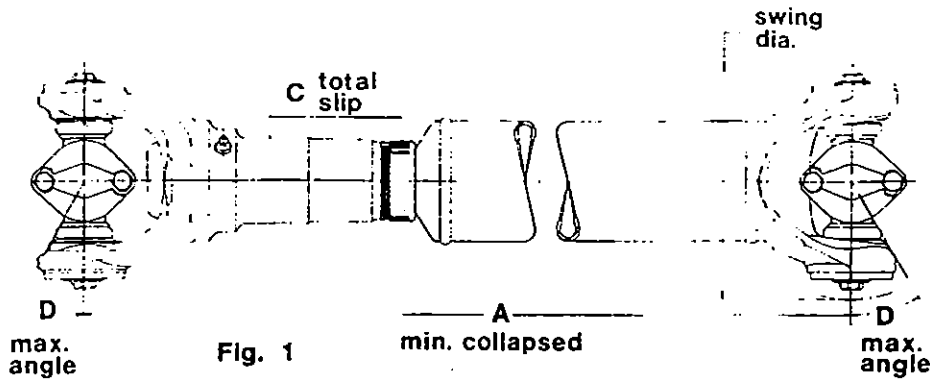

Fig. 1

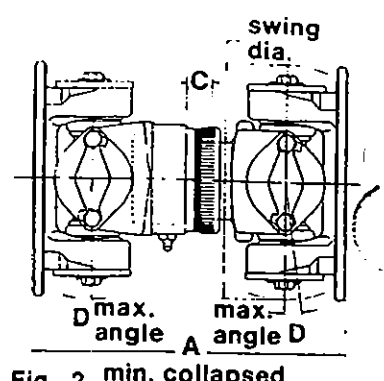

Fig. 2

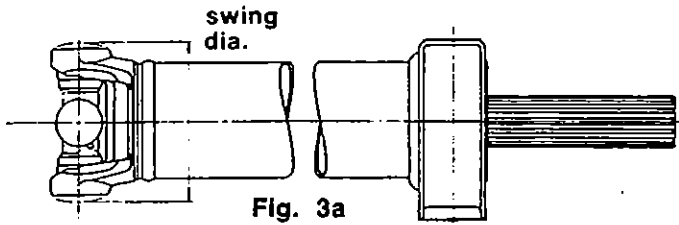

Fig. 3a

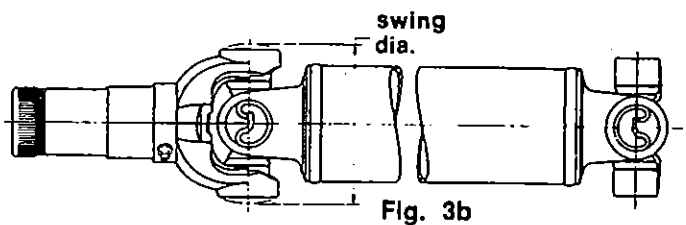

Fig. 3b

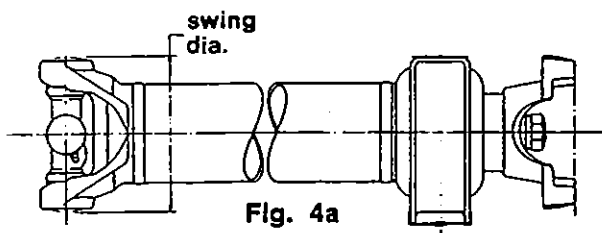

Fig. 4a

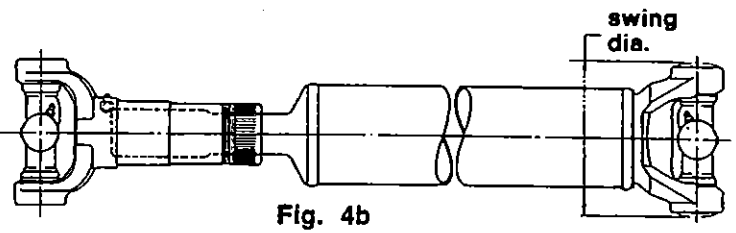
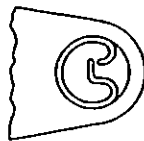
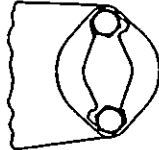

Fig. 4b

### Inboard Yoke Construction



snap ring  
S-R



bearing plate  
B-P



cap & bolt  
C&B

SPICER U-JOINT SIZES	Swing Dia.	FIGURE 1 (TUBULAR)			FIGURE 2 (SHORT COUPLED)			Inboard Yoke Construction	FIGURES 3 & 4 Coupling Shaft (a) Driveshaft (b) Series Availability			
		A Min. Collapsed	C Slip	D Max. Angle	A Min. Collapsed	C Slip	D Max. Angle		3a.	3b.	4a.	4b.
1000	2.50	9.13	1.75	50°	—	—	—	S-R	—	—	—	—
1210	3.00	—	—	23°	—	—	—	S-R	—	—	—	—
1280	3.75	3.56	3.13	30°	7.06	.81	5°	S-R	•	•	—	•
1310	3.75	3.56	3.13	30°	7.06	.81	5°	S-R	•	•	•	•
1330	4.13	10.25	2.75	15°	—	—	—	S-R	•	•	•	•
1350	4.25	11.63	3.63	30°	9.5	.75	12°	S-R	•	•	•	•
1410	4.69	12.31	3.47	28°	8.75	1.00	8°	S-R	•	•	•	•
1480	4.81	14.00	4.50	35°	8.50	1.00	8°	S-R	•	•	•	•
1550	5.63	15.38	5.00	35°	8.50	1.00	8°	S-R	•	•	•	•
1650	6.38	18.31	5.00	35°	9.00	1.00	8°	S-R	•	•	•	•
1610	7.00	17.44	4.88	34.5°	9.13	.75	8°	B-P	—	—	•	•
1710	7.75	18.38	5.25	29.5°	10.63	.75	8°	B-P	—	—	•	•
1810	9.13	19.75	5.00	30°	13.41	1.13	12°	B-P	—	—	•	•
1880	9.75	20.31	5.13	22.5°	13.63	1.00	8°	B-P	—	—	•	•
1910	8.88	21.88	2.95	15°	21.65	1.57	15°	C & B	—	—	—	—
1950	11.25	26.81	5.00	20°	33.94	2.31	20°	C & B	—	—	—	—
2050	14.13	31.81	2.88	20°	33.75	1.88	17°	C & B	—	—	—	—
2150	17.50	37.94	5.00	19.5°	—	—	—	C & B	—	—	—	—



# SECTION 10: FRONT AXLE

---

## CONTENTS

1. FRONT AXLE.....	2
1.1 Description .....	2
2. LUBRICATION .....	2
3. MAINTENANCE.....	2
4. REMOVAL AND REPLACEMENT .....	2
4.1 Removal.....	2
4.2 Replacement.....	3
5. SERVICE INSTRUCTION FOR STEER AXLE.....	3
6. FRONT WHEEL ALIGNMENT .....	3
6.1 Minor front Wheel Alignment .....	3
6.2 Major Front Wheel Alignment.....	4
6.3 Inspection Before Alignment.....	4
6.4 Turning Angle Adjustment .....	4
6.5 Mechanical Stop .....	4
6.5.1 R.H. Turn Adjustment .....	5
6.5.2 L.H. Turn Adjustment.....	5
6.6 Hydraulic Stop .....	5
6.7 Front Wheel Camber .....	6
6.7.1 Camber Check.....	6
6.8 Front Axle Caster.....	7
6.9 Front Wheel Toe-in.....	7
6.9.1 Inspection and Adjustment .....	8
7. TROUBLESHOOTING.....	9
8. SPECIFICATIONS .....	10

## 1. FRONT AXLE

### 1.1 Description

All H3 vehicles have a front axle of the "Reverse Elliot" type manufactured by GKN. The front axle consists of a girder section axle bed or beam with stub axles. Each stub axle is carried on a taper king pin, with a steep angle taper roller bearing at its top and a plain phosphor bronze bush at the bottom. The hub taper roller bearings are of a generous size and they are adjusted by means of shims, and secured by a special nut and washer. Brakes are manufactured by KNORR-BREMSE. Steering ball joints with hardened balls and rubbing pads incorporate compression springs which automatically take up any wear.

The tie rod simplifies toe-in adjustment. The maximum turning angle is set through stop screws installed on the inner side of the knuckle.

Steering stabilizer (damper), hydraulic cylinder and steering drag link which are mounted on the front axles are described in Section 14 of this manual "Steering".

## 2. LUBRICATION

Perform periodic lubrication. Lubrication points of the front axles are shown on the lubrication and servicing chart annexed to Section 24, "Lubrication". Grease fittings such as the tie rod ends and knuckle pins are provided with grease fittings for pressure lubrication. These grease fittings should be serviced every 6,250 miles (10 000 km) or twice a year whichever comes first. Good quality lithium-base grease NLGI No. 1 and 2 are recommended.

## 3. MAINTENANCE

A periodic inspection of the front axle assembly should be made to check that all bolts are tight, and that no damage and distortion have taken place. Suspension support stud nuts, U-bolt nuts, tie rod arms, steering arm nuts, and stop screws

should be checked and tightened, if necessary, to the torque specifications given at the end of this section. Also check the condition of the steering knuckle pins and bushings. In case of excessive looseness, the bushings and pins should be replaced.

Any looseness in the steering linkage under normal steering loads is a sufficient cause to immediately check all pivot pins for wear, regardless of accumulated mileage. Steering linkage pivot points should be checked each time the axle assemblies are lubricated. Looseness in the steering linkage pivot points can be visually detected during rotation of the steering wheel.

Steering knuckles, knuckle pins, and bushings may be replaced without removing the axle from the vehicle. However, if extensive overall work of the front axle is necessary, the axle should be removed.

## 4. REMOVAL AND REPLACEMENT

The following procedure deals with the removal of the front axle assembly. The method used to support the axle and suspension components during removal and disassembly depends upon local conditions and available equipment.

### 4.1 Removal

1. Raise the vehicle by its jacking points on the body (see Section 18, "Body" under heading, "Vehicle Jacking Points") until vehicle body is approximately 20 inches (508 mm) from the floor. Place jack stands under frame. Remove the wheels (if required, refer to Section 13, "Wheels, Hub and Tires").
2. Exhaust compressed air from the air supply system by opening the drain valve of each air reservoir.

3. Install jacks under axle jacking points to support the axle weight.

**Warning:** *To help prevent personal injury caused by the axle rolling off the jacks, the jack lifts should be equipped with U-adaptors, or similar equipment.*

4. Disconnect the steering drag link from the steering arm.
5. Remove the ABS sensors from their location in the hub units (if vehicle is so equipped).
6. Disconnect the height control valve link from its support on the axle.
7. Disconnect the hoses from brake chambers.

**Note:** *Position the air lines so that they will not be damaged when removing the axle.*

8. Remove the steering stabilizer cylinder (damper) and the hydraulic cylinder from steering top lever.
9. Remove bolts and nuts fixing the steering (damper) and the hydraulic cylinder mounting support to the front axle.
10. Remove the bolts and nuts fixing the axle to the left-hand and right-hand side air bellows mounting supports.
11. Use the jacks to lower axle. Carefully pull away the jacks and axle assembly from under the vehicle.

## 4.2 Replacement

Reverse removal procedure to reinstall the axle. Make sure that the air bellows support mounting plates are clean.

**Note:** *Refer to Section 16, "Suspension", Section 14, "Steering" and to paragraph "6. Specifications" at the end of this section for proper torque tightening.*

## 5. SERVICE INSTRUCTIONS FOR STEER AXLE

Refer to GKN Parts and service manual for axles annexed to the end of this section. See Section B

## 6. FRONT WHEEL ALIGNMENT

Correct front wheel alignment must be maintained for ease of steering and satisfactory tire life. Road shocks, vibrations, normal stress and strains on the front-end system under average operation can result in loss of front wheel alignment.

Check the front wheel alignment when the following occurs:

1. Every 200,000 miles (320 000 km) or 24 months (normal maintenance);
2. When the vehicle does not steer correctly; or
3. To correct a tire wear condition.

There are two types of front wheel alignments: a minor alignment and a major alignment.

### 6.1 Minor Front Wheel Alignment

Perform a minor front wheel alignment for all normal maintenance conditions.

Perform the minor front wheel alignment in the following sequence:

1. Inspect all the systems that affect the wheel alignment. See paragraph "6.3 Inspection Before Alignment" in this section.
2. Check and adjust the hub bearings, See Section 13, "Wheels, Hubs and Tires", under heading "To Assemble the Hub".
3. Check and adjust the toe-in.

## 6.2 Major Front Wheel Alignment

Perform a major front wheel alignment to correct steering and tire wear conditions.

Perform the major front wheel alignment in the following sequence:

1. Inspect all the systems that affect the wheel alignment. See paragraph "6.3 Inspection Before Alignment" in this section.
2. Check and adjust the hub bearings. See Section 13, "Wheels, Hubs and Tires", under heading "To Assemble the Hub".

**Note:** *If steering angle stoppers are changed, a special procedure is required for readjusting gearbox poppet valves. (see paragraph 6.6 of this section).*

3. Check and adjust the turning angle adjustment.
4. Check the camber angle.
5. Check and adjust the caster angle.
6. Check and adjust the toe-in.

## 6.3 Inspection Before Alignment

Check the following before doing a front wheel alignment:

1. Ensure that the vehicle is at normal ride height (see Section 16, "Suspension" under heading "Suspension Height Adjustment").
2. Ensure that front wheels are not the cause of the problem (refer to Section 13, "Wheels, Hubs and Tires"). Inspect the tires for wear patterns that indicate suspension damage or misalignment.

- a. Make sure the tires are inflated to the specified pressure.
- b. Make sure the front tires are the same size and type.
- c. Make sure the wheels are balanced.
- d. Check wheel installation and straightness.
3. Check the wheel bearing adjustment.
4. Check steering linkage for bending and pivot points for looseness.
5. Check knuckle pins for evidence of excessive wear.
6. Check radius rods for bending and rubber bushings for evidence of excessive wear.
7. Make sure all fasteners are tightened to the specified torque. Use a torque wrench to check the torque in a tightening direction. As soon as the fastener starts to move, record the torque. Correct if necessary. Replace any worn or damaged fasteners.

## 6.4 Turning Angle Adjustment

The maximum turning angle is set through the two steering stop screws installed on the axle center. The turning angle is factory adjusted to accommodate the chassis design, and therefore, does not require adjustment on new vehicles. However, these should be checked and adjusted, if necessary, any time any component of the steering system is repaired, disassembled or adjusted.

Proceed with the following method to check steering maximum turn angle.

## 6.5 Mechanical Stop

Check if front tires rub against the frame or if the steering gear has been serviced.

### 6.5.1 R.H. Turn Adjustment

1. Turn steering wheel to the right until the boss on the axle touches the right stop screw.
2. Verify the nearest point of contact of the ball socket body with the air bellows support assembly. Measure the distance between those two points.
3. The distance between these two points should be approximately 1/8 inch (3 mm). If not, the steering stop screws must be readjusted.
4. Check the nearest point of contact of the drag link with the tire. Measure the distance between these two points.
5. The distance should be 1 inch (25 mm) or more. If not, the steering stop screws must be readjusted.
6. This must be done for a full right turn.
7. If readjustment is required:
  - a. Remove the swivel stop screw.
  - b. Add to the stop screw the required number of washers to obtain the proper measure. Tighten the stop thicknesses are available: 1/16 inch and 3/16 inch spacers.

4. Check the stroke of the steering stabilizer cylinder (damper). It should not exceed 12.59 inches.
5. This must be done for a full left turn.
6. If readjustment is required:
  - a. Remove the swivel stop screw.
  - b. Add to the stop screw the required number of washers to obtain the proper measure. Tighten the stop screw afterwards. Two washer thicknesses are available: 1/16 inch and 3/16 inch spacers.

**Note:** *If steering angle stoppers are changed, a special procedure is required for readjusting gearbox poppet valves (see paragraph 6.6 of this section).*

### 6.6 Hydraulic Stop

**Note:** *Before poppet valve readjustment, verify vehicle wheel alignment, and ensure that oil level is checked and that air bleeding is done.*

Refer to "TAS Steering Gear Service Manual" annexed to Section 14, "Steering", under headings: "Filling and Air Bleeding the System" and "Poppet Readjustment".

### 6.5.2 L.H. Turn Adjustment

1. Turn steering wheel to the left until the boss on the axle touches the left stop screw.
2. Verify the nearest point of contact of the ball socket body with the air bellows support assembly. Measure the distance between these two points.
3. The distance should be approximately 1/8 inch (3 mm). If not, the steering stop screws must be readjusted.

## 6.7 Front Wheel Camber

Wheel camber is the number of degrees the top of the wheel tilts outward (positive) or inward (negative) from a vertical plane (Fig.1).

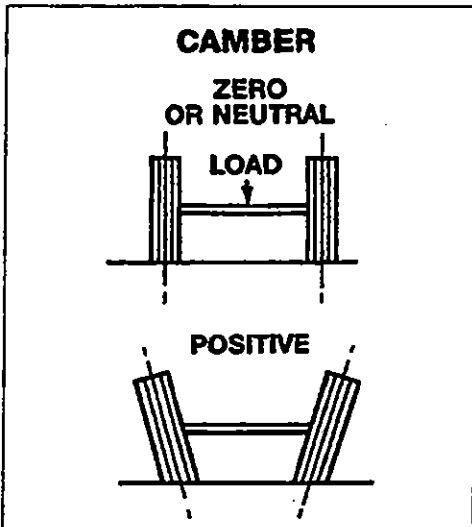

Figure 1: Camber

10006

The camber angle is not adjustable. Camber variations may be caused by wear at the wheel bearings, steering knuckle pins, or by a bent knuckle or sagging axle center. Steering effort is affected by improper camber, and uneven tire wear will result. Excessive positive camber causes an irregular wear of tire at the outer shoulder, and excessive negative camber causes wear at the inner shoulder.

### 6.7.1 Camber Check

CAMBER (UNDER LOAD)			
Specifications	Minimal	Nominal	Maximal
For axle serial 000 to 00__	-0.25°	0.25°	+0.75°
For axle serial 00__ and up__	-0.5°	0°	+0.5°

**Note:** Camber angle varies with axle loading. If the vehicle is not completely empty, please refer to the camber angle curve in the specifications at the end of this section .

1. Use an alignment machine to check the camber angle.
2. If camber reading is not in the specifications, adjust the wheel bearings and repeat the check. If the reading is still not within specifications, verify the steering knuckle pins and axle center.

See instructions in "GKN Parts and Service Manual For Axles", annexed to the end of this section, under heading "To Remove the Stub Axle Assembly" .

3. Check the wheel lateral distortion as instructed in Section 13, "Wheels, Hubs and Tires". If distortion is excessive, straighten or replace wheel(s).



## 6.8 Front Axle Caster

Caster Specifications			
	Minimal	Nominal	Maximal
Caster (G), degrees	+ 2	+ 2 3/4	+ 3 1/2

Positive caster is the rearward tilt from the vertical axis of the knuckle pin. Negative caster is the forward tilt from the vertical axis of the knuckle pin (Fig. 2). This vehicle is designed with a positive caster. The purpose of the caster angle is to give a trailing effect. This results in stabilized steering and a tendency for the wheels to return to the straight-ahead position after taking a turn.

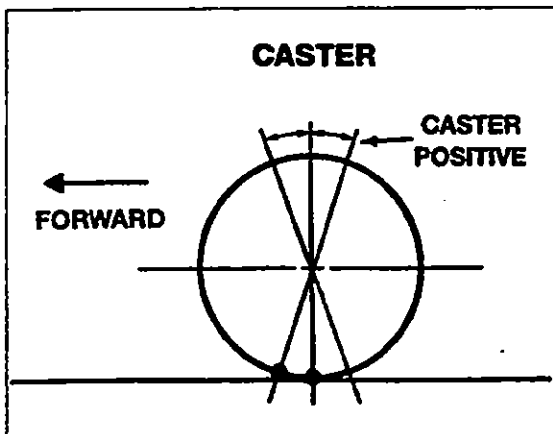

Figure 2: Caster

10007

Excessive caster results in hard steering around corners. A shimmy may also develop when returning to the straight-ahead position (pulling out of curves).

Insufficient caster will cause wandering and steering instability. Caster variations may be caused by a bent axle, tilting or distortion of the side suspension supports, damaged radius rod bushings, or unequal tightening of the front and rear suspension support bolts. Incorrect caster must be corrected by replacing the damaged suspension parts. A precision instrument should be used to measure the caster.

**Note:** The caster of this vehicle is factory set and is nonadjustable. However, if after replacing damaged parts on the vehicle or in case of improper caster due to irregular setting, the front axle caster can be adjusted by means of shims (number 11-0663) on the left-hand side upper radius rod support in order to obtain minor adjustment.

## 6.9 Front Wheel Toe-in

Wheel toe-in is the degree (usually expressed in fractions of an inch) to which the forward part of the vehicle front wheels are closer together than the rear part, measured at wheel centerline height with the wheels in the normal "straight-ahead" position of the steering gear. Incorrect toe-in results in excessive tire wear caused by side slippage and also steering instability with a tendency to wander. Toe-in may be measured from the center of tire treads or from the inside of the tires. Take measurements at both front and rear of axle (see "A" and "B" in Fig. 3).

When setting "toe-in" adjustment, the front suspension must be neutralized; that is, all component parts must be in the same relative position when making the adjustment as they will be when in operation.

To neutralize the suspension, the vehicle must be rolled forward, approximately ten feet.

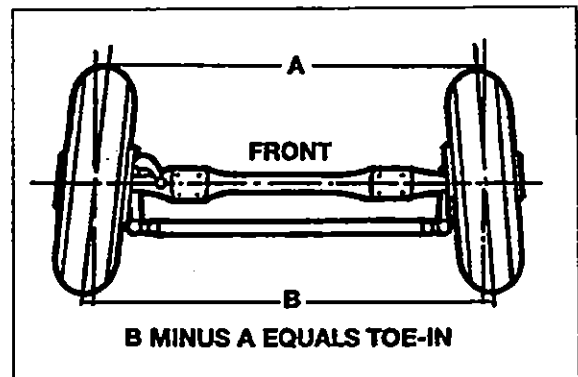

Figure 3: Toe-in

10008

## Section 10: FRONT AXLE

Toe-in Specifications			
	Minimal	Nominal	Maximal
Toe-in (F minus E), inches	+ 1/16	+ 3/32	+ 1/8

By rolling the vehicle forward, all tolerances in the front suspension are taken up and the suspension is then in its normal operating position. Neutralizing the front suspension is extremely important, especially if the vehicle has been jacked up in order to mark the tires. Otherwise the front wheels will not return to their normal operating position due to the tires gripping the floor surface when the vehicle jack is lowered.

**Note:** "Toe-in" measurements must be taken at the horizontal axis of the wheel centerline.

### 6.9.1 Inspection and Adjustment

Before checking front wheel toe-in, first check the camber angles and make the necessary corrections.

1. Measure the toe-in.
2. If the toe measurement is not at the specified distance, Refer to the following procedure:
  - a. Loosen the pinch bolt nuts and bolts on each end of the tie rod.
  - b. Turn the tie rod until the specified toe-in distance is obtained.
  - c. Tighten pinch bolt nuts alternately and progressively to 65-75 lbf-ft (88-102 N·m), thus securing all joint to tie rod.

## 7. TROUBLESHOOTING

CONDITION	CAUSE	CORRECTION
Tires wear out quickly or have uneven tire tread wear.	<ol style="list-style-type: none"> <li>1. Tires have incorrect air pressure.</li> <li>2. Tires out-of-balance.</li> <li>3. Incorrect tag axle alignment.</li> <li>4. Incorrect toe-in setting.</li> <li>5. Incorrect steering arm geometry.</li> </ol>	<ol style="list-style-type: none"> <li>1. Put specified air pressure in tires.</li> <li>2. Balance or replace tires.</li> <li>3. Align tag axle.</li> <li>4. Adjust toe-in specified setting.</li> <li>5. Service steering system as necessary.</li> </ol>
Vehicle is hard to steer.	<ol style="list-style-type: none"> <li>1. Low pressure in the power steering system.</li> <li>2. Steering gear not assembled correctly.</li> <li>3. Steering linkage needs lubrication.</li> <li>4. King pins binding.</li> <li>5. Incorrect steering arm geometry.</li> <li>6. Caster improperly adjusted.</li> <li>7. Tie rod ends hard to move.</li> <li>8. Worn thrust bearing.</li> </ol>	<ol style="list-style-type: none"> <li>1. Repair power steering system.</li> <li>2. Assemble steering gear correctly.</li> <li>3. Lubricate steering linkage.</li> <li>4. Replace king pins.</li> <li>5. Service steering system as necessary.</li> <li>6. Adjust caster as necessary.</li> <li>7. Replace tie rod ends.</li> <li>8. Replace thrust bearing.</li> </ol>
Bent or broken steering arm, steering top lever, tie rod assembly	<ol style="list-style-type: none"> <li>1. Too much pressure in the power steering system.</li> <li>2. Cut-off pressure of the power steering system improperly adjusted.</li> <li>3. Vehicle not powered on correctly.</li> <li>4. Power steering system not installed correctly.</li> </ol>	<ol style="list-style-type: none"> <li>1. Adjust power steering system to specified pressure.</li> <li>2. Make sure vehicle is powered on correctly.</li> <li>3. Correctly install the power steering system.</li> </ol>
Worn or broken steering ball stud.	<ol style="list-style-type: none"> <li>1. Drag link fasteners tightened past specified torque.</li> <li>2. Lack of lubrication or incorrect lubricant.</li> <li>3. Power steering stops improperly adjusted.</li> </ol>	<ol style="list-style-type: none"> <li>1. Tighten drag link fasteners to specified torque.</li> <li>2. Lubricate linkage with specified lubricant.</li> <li>3. Adjust stops to specified dimension.</li> </ol>
Worn king pins and knuckle bushings.	<ol style="list-style-type: none"> <li>1. Worn or missing seals and gaskets.</li> <li>2. Incorrect lubricant.</li> <li>3. Axle not lubricated at scheduled frequency.</li> <li>4. Incorrect lubrication procedures.</li> <li>5. Lubrication schedule does not match operating conditions.</li> </ol>	<ol style="list-style-type: none"> <li>1. Replace seals and gaskets.</li> <li>2. Lubricate axle with specified lubricant.</li> <li>3. Lubricate axle at scheduled frequency.</li> <li>4. Use correct lubrication schedule to match operating conditions.</li> </ol>
Vibration or shimmy of front axle during operation.	<ol style="list-style-type: none"> <li>1. Caster not adjusted properly.</li> <li>2. Wheels and/or tires out-of-balance.</li> <li>3. Worn steering stabilizer cylinder.</li> </ol>	<ol style="list-style-type: none"> <li>1. Adjust caster.</li> <li>2. Balance or replace wheels and/or tires.</li> <li>3. Replace steering stabilizer cylinder.</li> </ol>

## 8. SPECIFICATIONS

### Front Axle

Make .....GKN  
Axle type .....S-82  
Front track..... 84.4 inches / 2145 mm  
Capacity (each)..... 18,067 lbs / 8 200 kg

### Torque Specifications

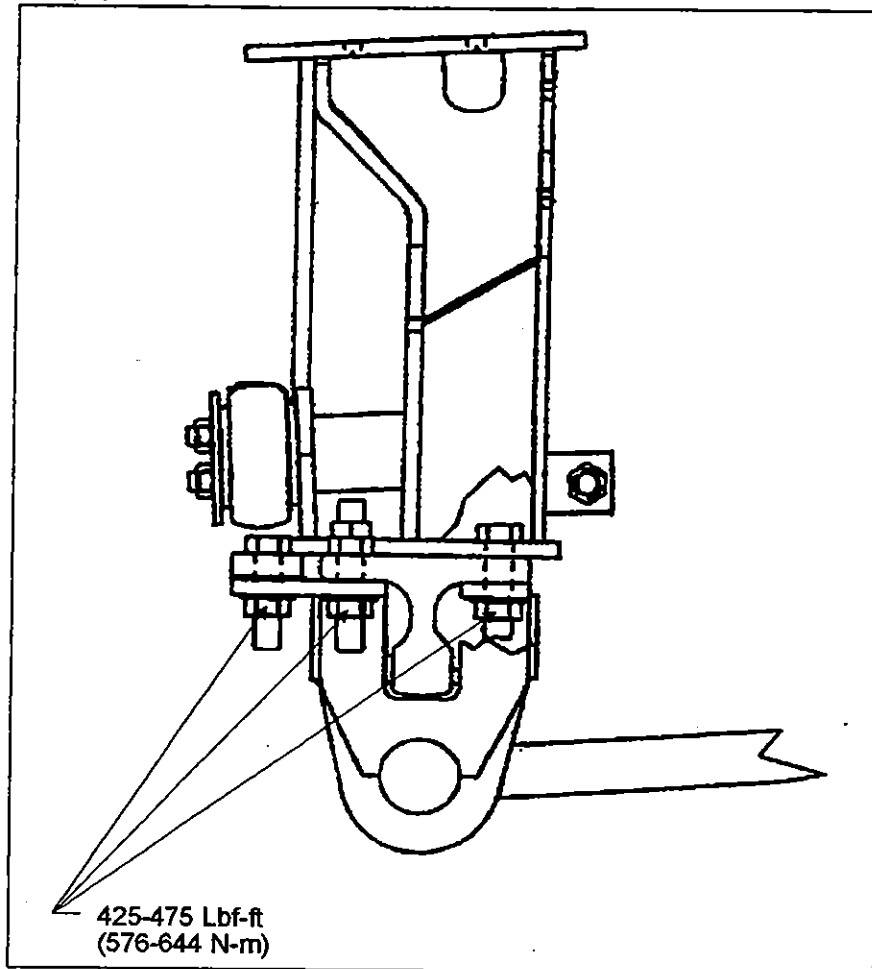

Figure 4: Air Bellows Mounting Support and Axle

10009

For more torque specifications, see "GKN Parts and Service Manual For Axles", Manual No. 1604, Issue A, Section B annexed to the end of this section, under heading "Tightening Torque Table for Type S82 Steer Axle".

FRONT WHEEL ALIGNMENT SPECIFICATIONS			
Front Wheel Alignment	Minimal	Nominal	Maximal
Camber (C), degrees R.H. and L.H. *	-1/2	0	+1/2
Caster (G), degrees R.H. and L.H.	+ 2	+ 2 3/4	+ 3 1/2
Toe-in (F minus E), inches	+ 1/16	3/32	+ 1/8

**Note:** Camber angle changes with loading. The given numbers are for an empty vehicle. See chart below for possible correction, if loaded.

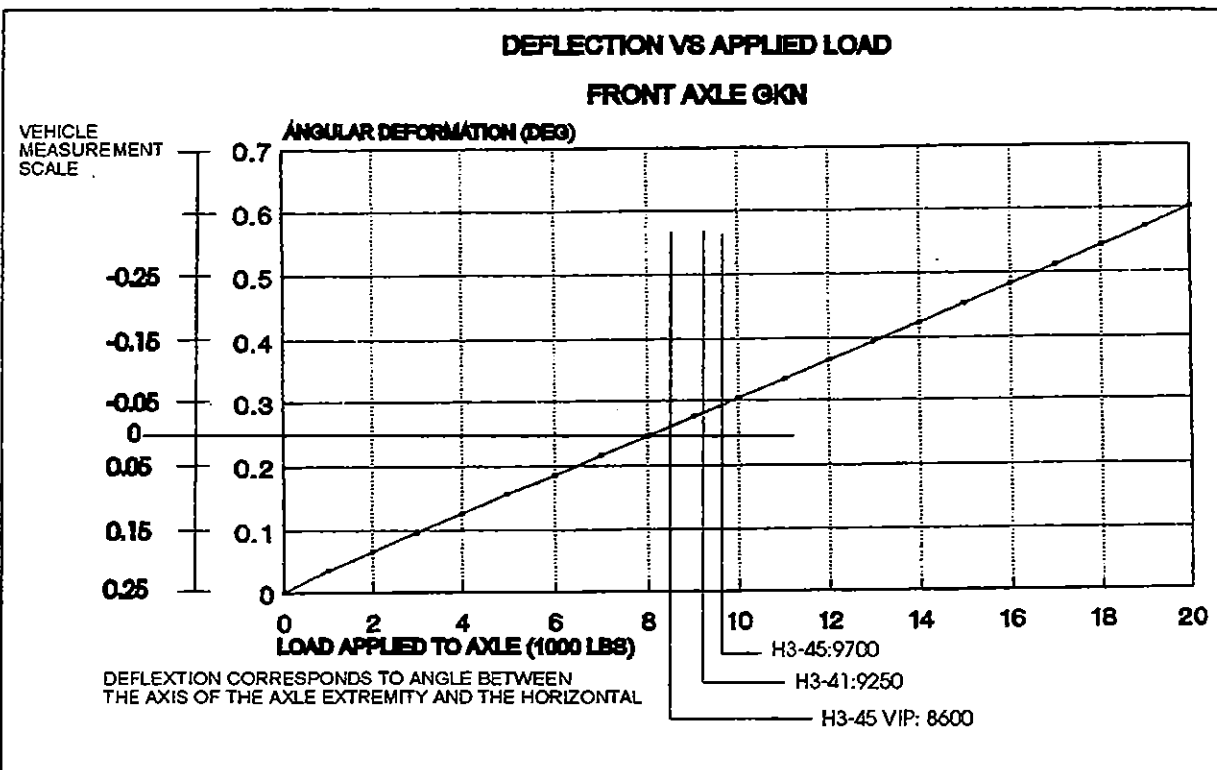
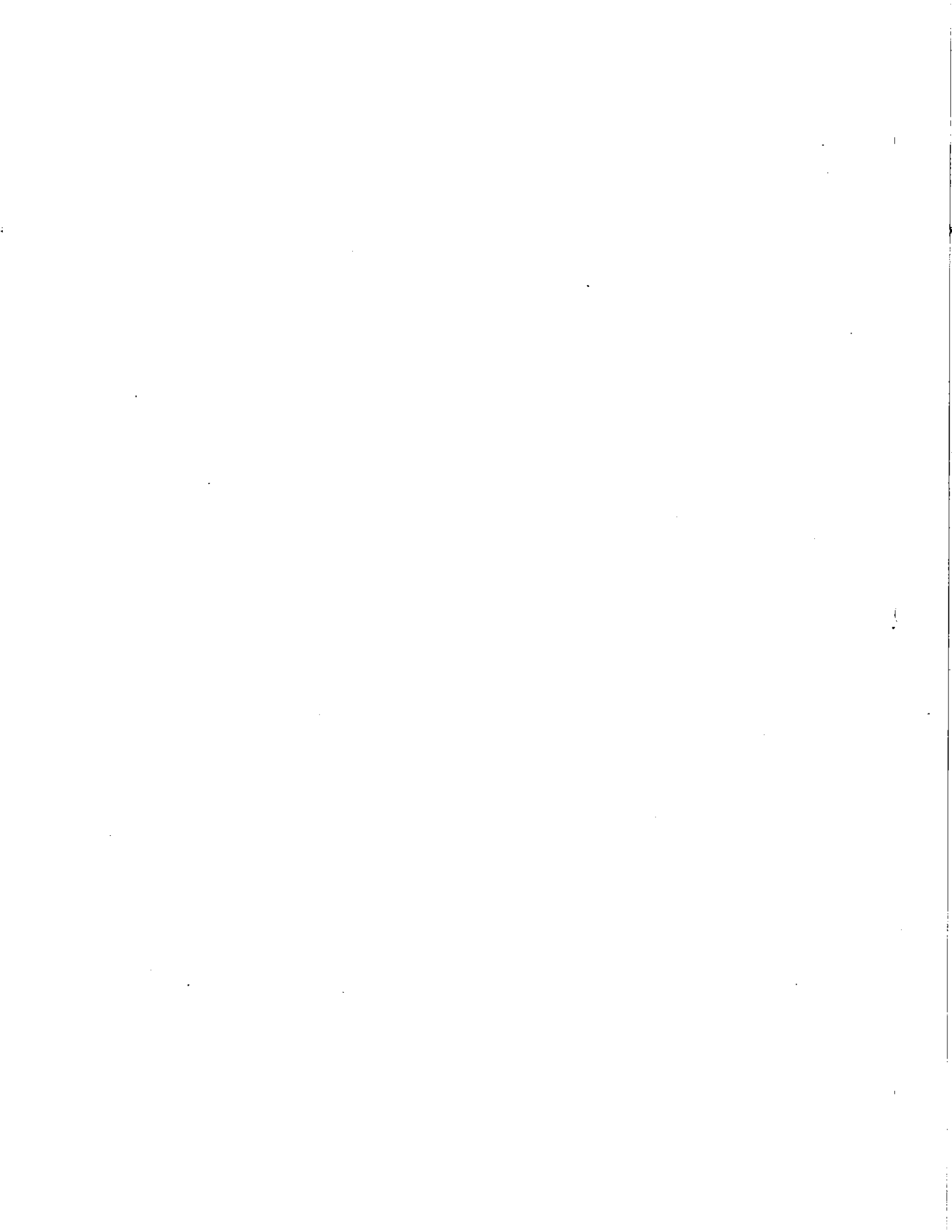
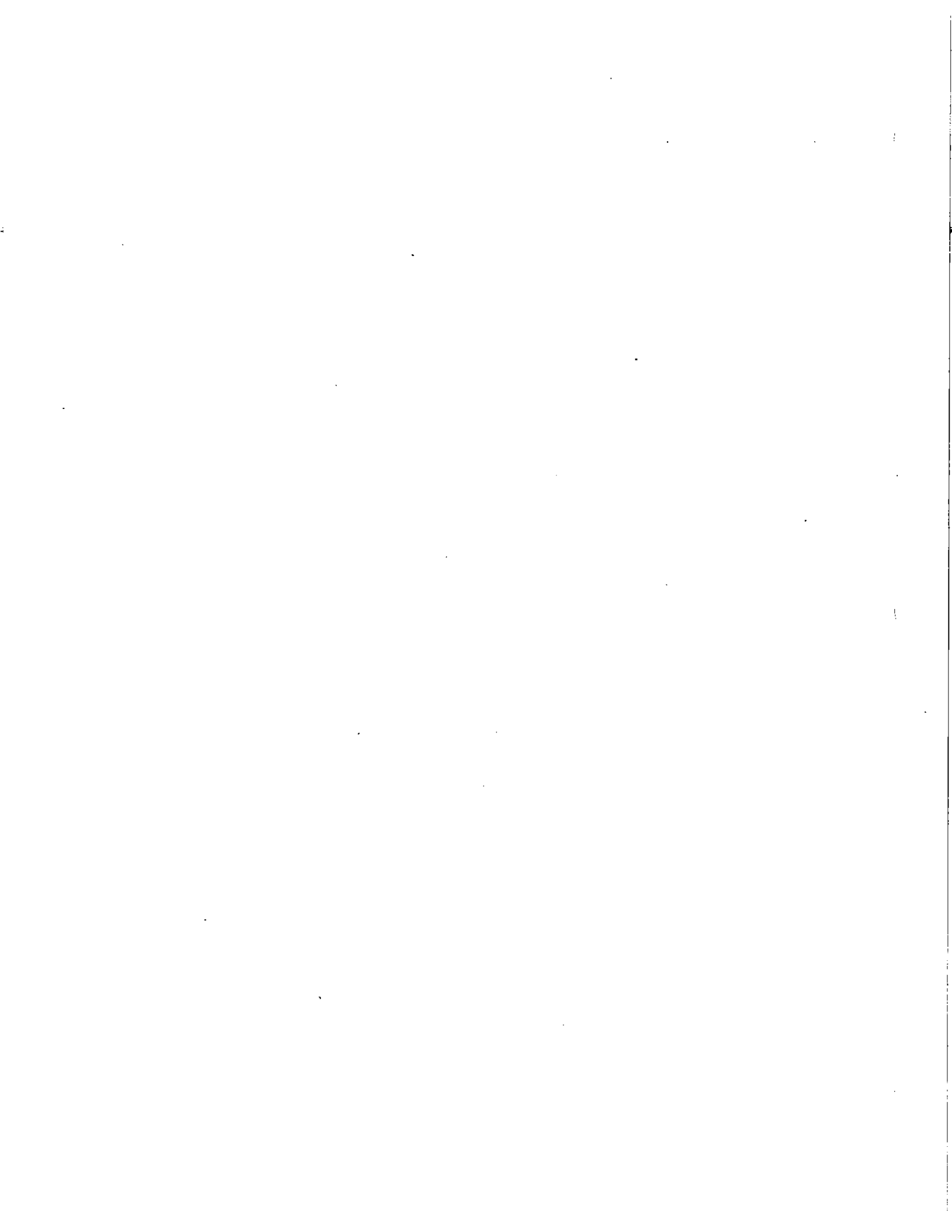

Figure 5: Deflection Versus Applied Load

10010









# **GKN AXLES LIMITED**

## **KIRKSTALL DIVISION**

**PARTS AND SERVICE MANUAL FOR  
AXLES FITTED TO  
PREVOST 6 X 2 COACH**

**MANUAL No.1604 Issue A**

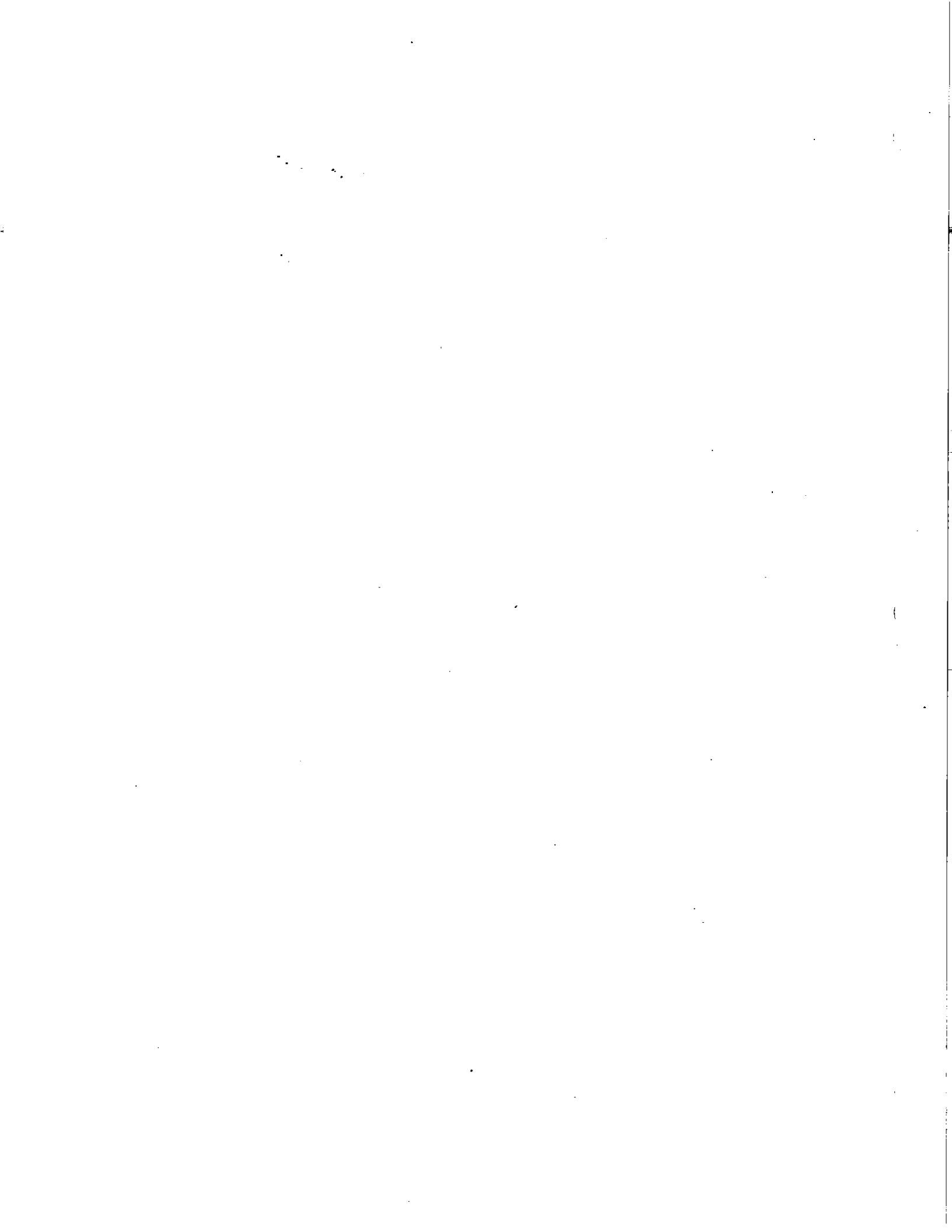



**PARTS AND SERVICE MANUAL  
FOR AXLES FITTED  
TO PREVOST 6 X 2 COACH**

**1st. AXLE TYPE S82  
AXLE ASSEMBLY No.25546  
CUST. REF. 610985**

**REF. DRAWING Nos.  
Hub F4651A  
Instl F4651E**

**2nd AXLE TYPE TS5  
AXLE ASSEMBLY No. 33533  
CUST. REF. 621535**

**REF. DRAWING Nos.  
Hub R9855C**



**The description, testing procedures, and specifications contained in this parts / service publication were current at time of printing. This manual will not be updated. If in doubt about any aspect of maintenance or servicing of the axle please contact the vehicle builder or our service department direct.**

**GKN Axles Ltd. Kirkstall Division reserves the right to discontinue or modify its procedures and to change specifications at any time without notice and without incurring obligation.**

**The recommendations of the vehicle manufacturer should be considered as the primary source of service information regarding this GKN Axles product. This manual is intended to be used as a supplement to such information.**

**Any references to brand names in this publication is made simply as an example of the types of tools and materials recommended for use and, as such, should not be considered as an endorsement. Equivalents, if available, may be used.**



**MANUAL ISSUE SHEET**

Page No.	Issue	Description / Alteration	Reason	Date
All	A	New manual		Aug. 94



**SECTION A LUBRICATION**

	<b>Page No.</b>
Front Page	A1
Lubrication instructions for type S82 steer axle	A2
Lubrication instructions for type TS5 trailing axle	A3
Notes	A4

**SECTION B SERVICE INSTRUCTIONS FOR STEER AXLE TYPE S82**

	Front page	B1
	Description	B2
Section 1	Routine maintenance	B2
Section 2	Removal of hub	B3
Section 3	Removal of stub axle	B3
Section 4	Dismantling ball socket assembly	B4
Section 5	Re-assembly of ball socket & tie rod	B5 & B6
Section 6	Re-fitting swivel assembly	B7
Section 7	Swivel bearing adjustment	B8
Section 8	Swivel final assembly	B9 & B10
Section 9	Assembly of hub	B11 to B13
Section 10	Final assembly	B14
	Tightening torque table for type S82 steer axle	B15
	Parts identification / spares lists	B16 & B17
	Notes	B18
	Illustration for steer axle type S82 (F47)	

**SECTION C SERVICE INSTRUCTIONS FOR TS5 HUB UNIT**

	Front Page	C1
	Description	C2
Section 1	Routine maintenance	C2
Section 2	Removal of hub unit	C2
Section 3	Assembly of hub unit	C3 to C5
	Tightening torque table for type TS5 hub unit	C6
	Parts list for TS5 hub unit	C7
	Notes	C8
	Illustration of TS5 hub unit (H86)	



**Axles Ltd. Kirkstall Division - Technical Publications**

**LUBRICATION INSTRUCTIONS FOR  
AXLES FITTED TO  
PREVOST 6 X 2 COACH**

**MANUAL SECTION A**

**LUBRICATION INSTRUCTIONS FOR TYPE S82 STEER AXLE**

- 1.1 Lubricate the stub axle and socket assemblies with one of the following recommended greases at regular intervals not exceeding 10,000 miles or 6 (six) weeks whichever occurs first at grease points as shown (fig. no.1).
- 1.2 Clean out and recharge hub & hub bearings every 12 months. See figure no.2 for amount of grease to be used.

**Recommended Greases**

Lithium base roller bearing grease NLGI - no.2 (Shell Retinax LX or equivalent).

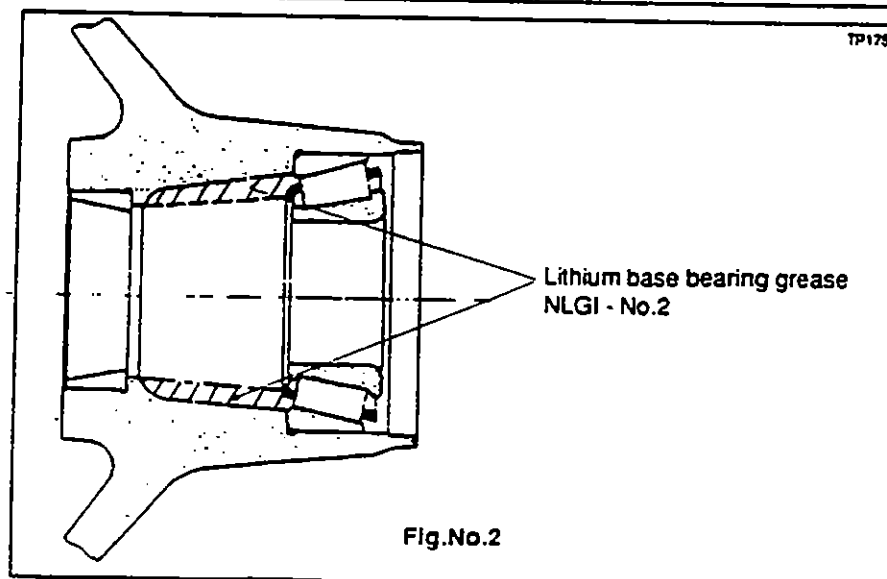
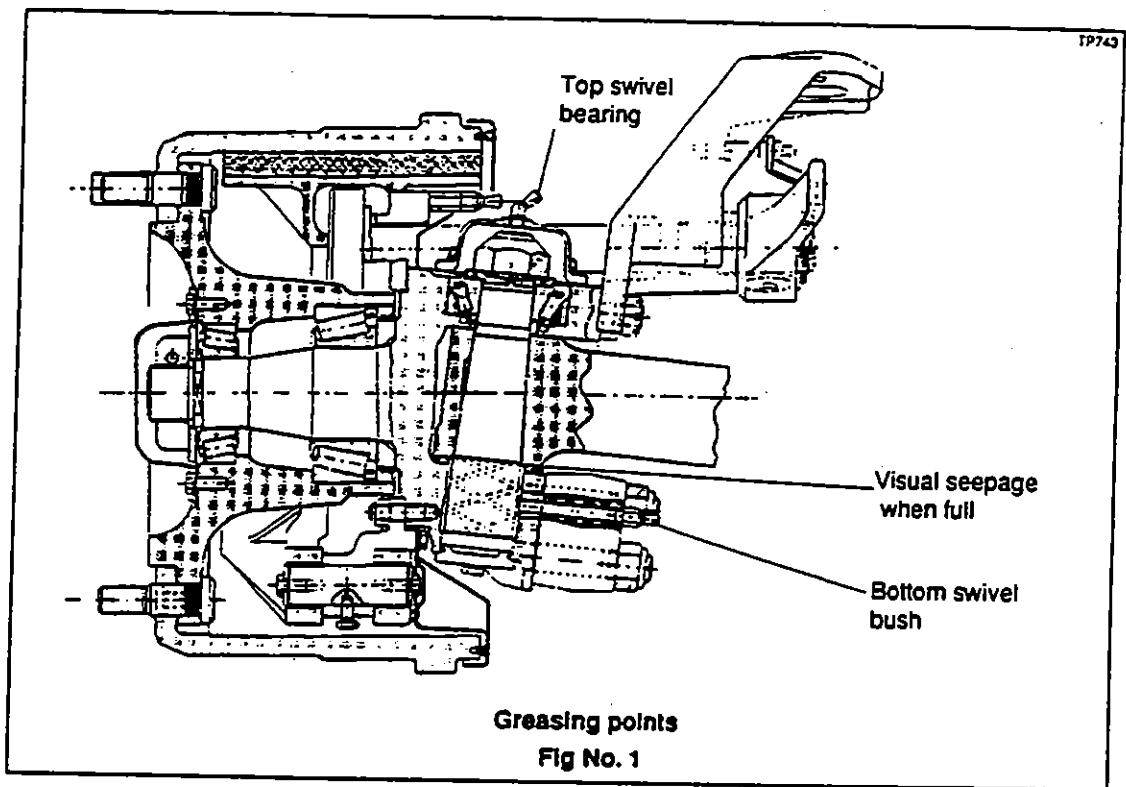





LUBRICATION INSTRUCTIONS FOR TS5 HUB UNIT  
WITH KNORR AIR DISC BRAKE

Clean out and recharge hub & hub bearings every 12 months. See figure no.3 for amount of grease to be used.

**Recommended Greases**

Lithium base roller bearing grease NLGI - no.2 (Shell Retinax LX or equivalent).

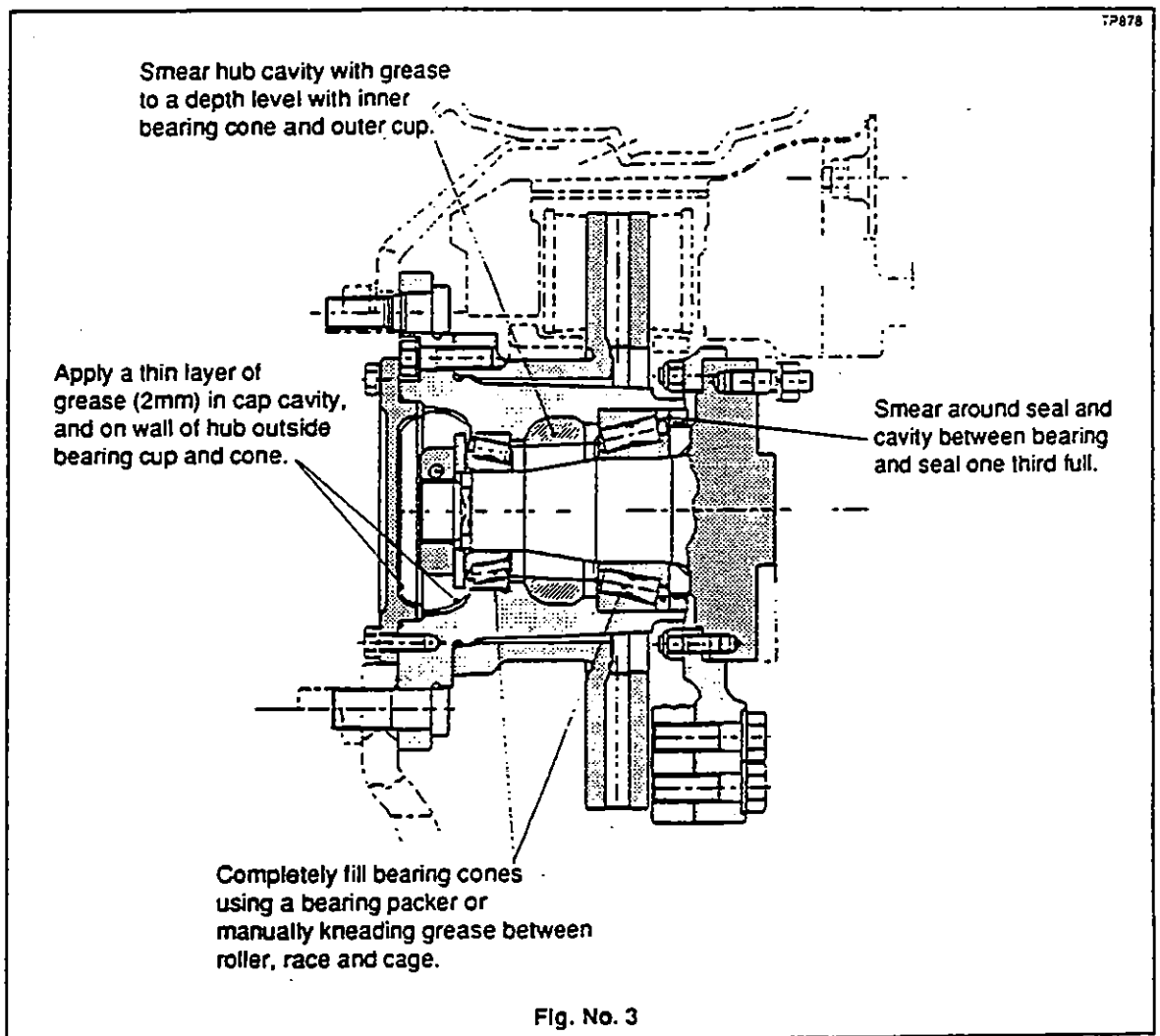

## Notes

 Axles Ltd. Kirkstall Division - Technical Publications

**PARTS AND SERVICE INSTRUCTIONS FOR S82 STEER AXLE  
WITH KNORR AIR DISC BRAKE**

**ILLUSTRATION No.F47**

**MANUAL SECTION B**

**PARTS AND SERVICE INSTRUCTIONS FOR TYPE S 82 STEER AXLE**

**DESCRIPTION**

The axle is of the 'Reverse Elliot' type comprising a girder section axle bed or beam with stub axles. Each stub axle is carried on a taper king pin, with a steep angle taper roller bearing at its top and a plain phosphor bronze bush at the bottom. The hub taper roller bearings are of a generous size and, adjusted by means of special split nut with 'D' washer. Brakes may be of GKN or proprietary manufacture which can be serviced without disturbing the hub. Steering ball joints with hardened balls and rubbing pads incorporate compression springs which automatically take up any wear.

**SECTION 1 ROUTINE MAINTENANCE**

**1.1 Hub bearing adjustment**

- a) An inspection should be made after the first 3,000 miles (4,800 km) and then at intervals of 25,000 miles (40,000km). With the wheels raised they should revolve quite freely without roughness.
- b) Hub bearings should have a slight end float movement within the limits 0.0005" to 0.002" when rocked forwards and backwards on axle stub. See section 8, page B9 if any adjustment is required.

**1.2 To check front wheel 'Toe In'**

- a) To preserve correct steering and avoid excessive tyre wear, tracking (or alignment) of the front wheels should be checked periodically, as follows :-  
Set the front wheels in straight ahead position and at points level with wheel centre, measure distance between edges of wheel rims, both in front and behind axle centre. For correct 'Toe In', front measurement 'B' should be 0" to  $\frac{1}{32}$ " smaller than rear measurement 'A'. See fig.no.1.
- b) To allow for inaccuracies in wheels, the same check should be made with vehicle moved an equivalent to half of wheel revolution. Any adjustment required can be effected by slackening the clamp bolts in ball sockets and rotating tie (track) rod tube. After adjustment, tighten clamp bolts to 51 - 62 lbs. ft. (69 - 84Nm.) torque.

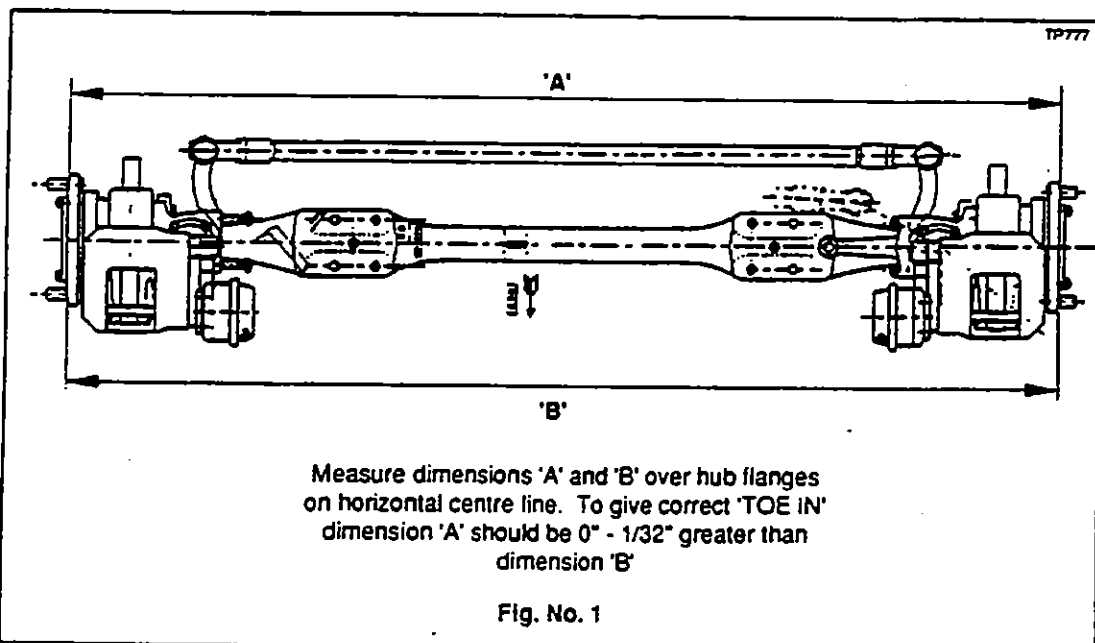



**SECTION 2 TO REMOVE HUB UNIT**

- 2.1 Chock the appropriate wheels.
- 2.2 Whilst road wheels are still on ground, loosen wheel nuts (7 posn.) slightly.
- 2.3 Raise vehicle, remove road wheel nuts and remove road wheels.
- 2.4 Disconnect air line from brake caliper (13).
- 2.5 Remove brake caliper setscrews with washers (16 & 15) then lift off brake caliper assembly (13).
- 2.6 Remove hub cap setscrews and washers (1 & 2).
- 2.7 Remove hub cap (3) with 'O' ring(4) then discard 'O' ring.
- 2.8 Remove hub bearing pinch bolt nut (5) and bolt (66), then remove hub bearing nut (67) along with hub bearing washer (6).
- 2.9 Remove hub (8) complete with its bearings (11/11A & 64/64A) and oil seal (12) then lift off outer bearing cone (64A).
- 2.10 Remove oil seal (12) and inner bearing cone (11A) from hub (8) .
- 2.11 Drive out hub bearing cups (11 & 64) from hub (8).
- 2.12 If hub bearing distance piece (oil seal wear sleeve) (60) shows signs of wear or corrosion it must be removed and replaced with a new part.

**SECTION 3 TO REMOVE THE STUB AXLE ASSEMBLY**

- 3.1 Remove split pin (46) followed by nut (47) with washer (48), then separate ball socket (39) from bottom lever (49) with suitable ball pin extractor.  
**Note :- When separating ball joint from steering lever, an extractor tool MUST be used. DO NOT strike areas around ball pin tapers with hammer blows under any circumstances due to possible ball pin taper deformation.**
- 3.2 Remove swivel top cap setscrews and washers ( 25 & 24), enabling swivel top cap (23) to be removed.
- 3.3 Remove sealant from top cap and swivel mating faces (23 & 58) using Loctite ' Chisel Gasket Remover ' or by carefully scraping sealant from faces .
- 3.4 Remove bottom cap setscrews and washers (53 & 54).
- 3.5 Pull off swivel bottom cap (55) then remove sealant from bottom cap and swivel mating faces (55 & 58) using Loctite ' Chisel Gasket Remover ' or by carefully scraping sealant from faces .
- 3.6 Remove swivel pin nut and washer (22 & 21).
- 3.7 Give axle beam (37) a sharp tap to loosen swivel pin (56). The swivel pin (56) can then be driven out downwards, thus releasing it from axle beam.
- 3.8 The swivel assembly can be removed from axle beam (56).
- 3.9 Take out swivel pin bearing (20/20A), swivel bearing adjustment shims (19), swivel bearing sleeve (17) and swivel pin oil seal (18) from top of swivel (58).
- 3.10 Take out swivel bush seal (52) and swivel pin bush (57) from bottom of swivel (58).
- 3.11 Remove bottom lever nuts (42), then pull off bottom lever (49).  
Care must be taken not to damage bottom lever studs (50 & 51).
- 3.12 Check the condition of swivel stop nut (33), and adjusting washer (32), removing for replacement if required.

**Inspection**

Thoroughly clean all parts, inspect for wear and renew if required.

**SECTION 4 DISMANTLING BALL SOCKET SEE FIG No 2.**

- 4.1 Remove dirt seal (15) also dirt seal (pressing) (16) from ball pin.
- 4.2 Slacken pinch bolt nut (10) then unscrew and remove ball socket assembly from tie rod having first marked ball socket body and tie rod to enable tracking on re-assembly.
- 4.4 Remove adjuster split pin (9) from ball socket body (3).
- 4.5 Remove cap (8) then using a suitable tool ie: a piece of 1" x 1/8" x 9" flat bar, unscrew and remove adjusting piece (7). Waggle ball (2) to free thrust cap (5).
- 4.6 Remove compression spring (6) also thrust cap (5) from ball socket body.
- 4.6 Relieve peening on socket body top (3) then using a hide faced mallet, tap ball pin (2) out of body.
- 4.7 This operation will also remove cover plate (1) from body (3).  
The rubbing pad (4) can now be removed from body (3).

Thoroughly clean all parts and check for wear, renewing where necessary.

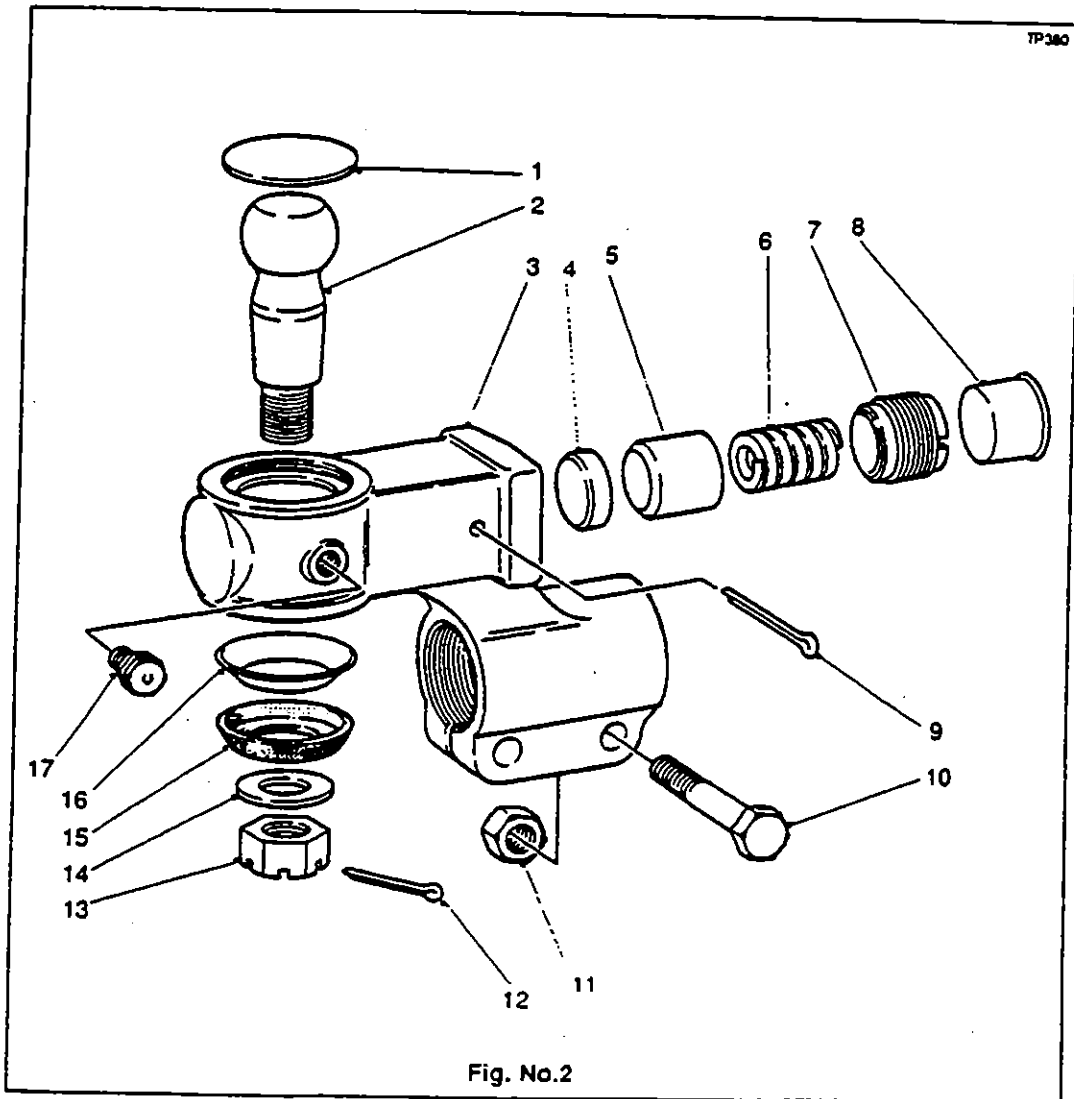

**SECTION 5 ASSEMBLY OF BALL SOCKET AND TIE ROD Fig No 3.**

**Note :-** Method of assembling ball socket is same for drop type shown and alternative straight body type.

- 5.1 Apply a bead of Loctite 638 sealant to mating corner of rubbing pad (4) in socket body (3) then knock rubbing pad (4) into its recess in ball socket body.
- 5.2 Thoroughly grease rubbing pad (4) and ball pin (2) with Shell 'Retinax LX' or equivalent.
- 5.3 Insert ball pin (2) into body.
- 5.4 Insert thrust cap (5), compression spring (6) and adjuster piece (7) into body.
- 5.5 Using a suitable tool ie: a 1" x 1/8" x 9" long flat bar, tighten adjuster piece (7) fully home (SOLID) locating thrust cup (5) onto ball pin (2).

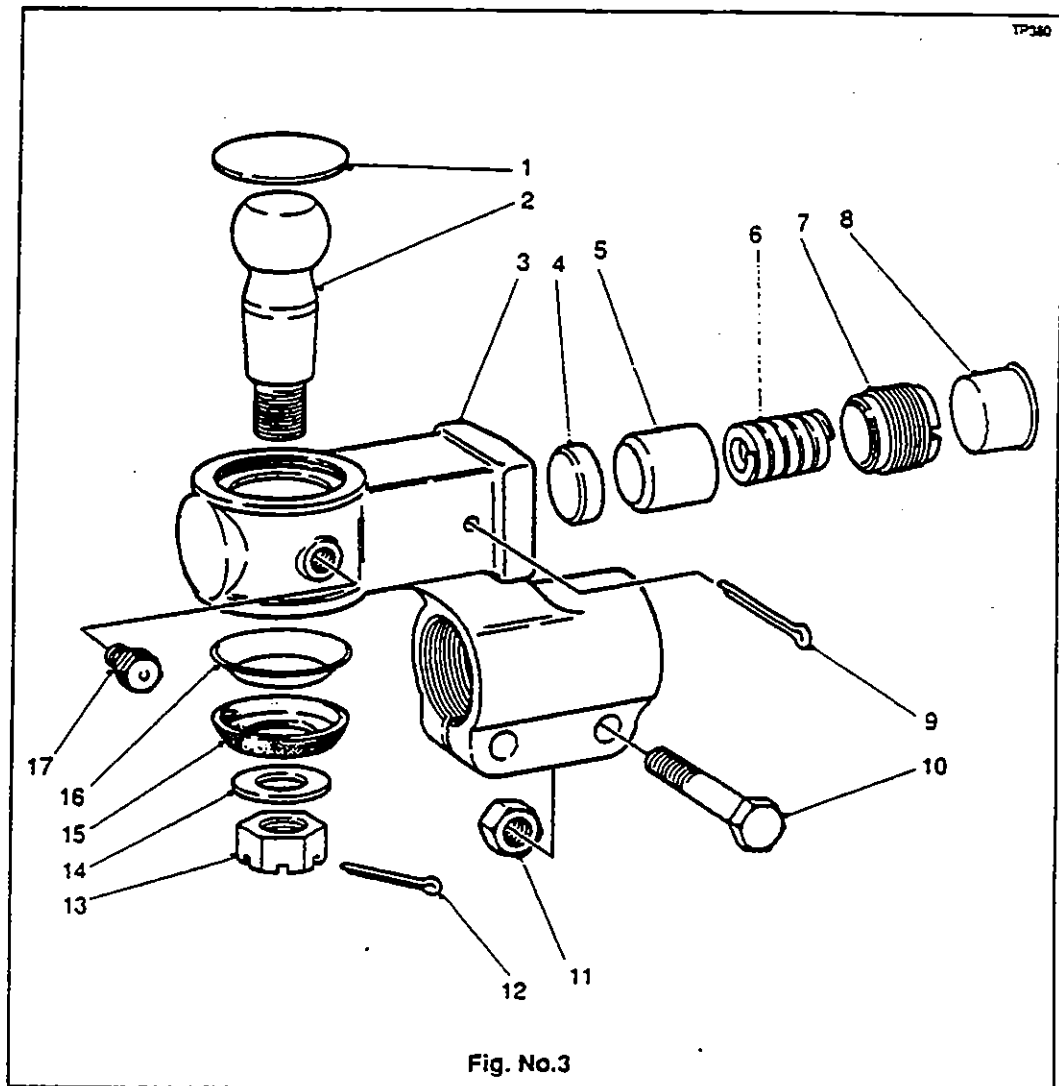

SECTION 5 ASSEMBLY OF BALL SOCKET AND TIE ROD Cont.

- 5.7 Still with tool located on adjuster piece (7), back off carefully (LEAST AMOUNT) until adjuster piece split pin (9) is allowed to pass through body, and that ball pin shank can be moved by force of hand, then remove tool.

Note :- If ball pin (2) does not rotate when re-adjusted in line with above instructions, this suggests that ball pin has local worn flats as shown in fig.no.4. In this instance ball pin (2), thrust cup (5) and rubbing pad (4) MUST be replaced, if not FAILURE could occur in service, ie ball pin (2) not being able to move in assembly when turning from lock to lock as shown in fig 5.

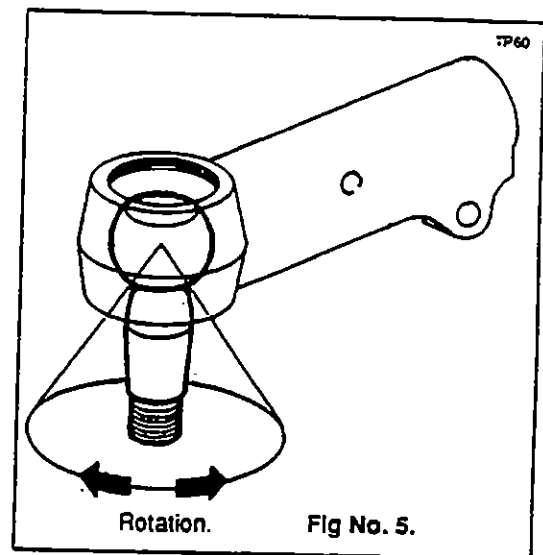
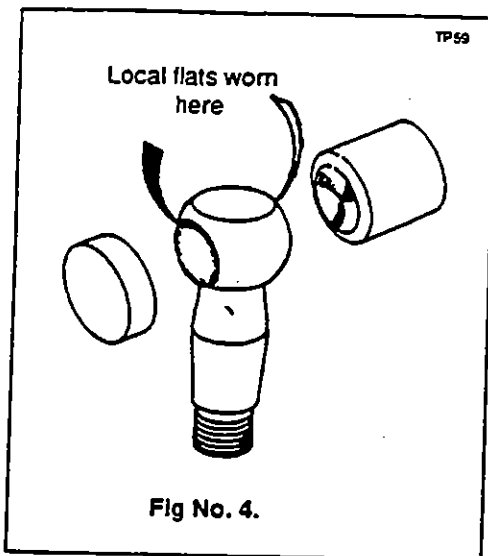

- 5.8 Fit cover plate (1) into top of ball socket body, re-peen using a cold chisel to secure.  
 5.9 Screw assembled ball socket onto tie rod. Lining up marks on both body and tie rod previously made, or retracting using manual instructions.  
 5.10 Fit pinch bolts (10) and nuts (11) then tighten nuts (11) alternately and progressively to 65 - 75lbs.ft. (88 - 102Nm.) thus securing ball joint to tie rod.  
 5.11 Fit dirt seal (pressing) (16) and dirt seal (rubber) (15) onto ball pin (2).  
 5.12 Locate ball socket and tie rod assembly with steering lever, carefully align and fit ball pin (2) into hole in steering lever.

Note :- Ball pin (2) and ball pin tapers in bottom steering levers (49 - F47) must be clean, dry and free from oil prior to assembly.

- 5.13 Fit pin washer (14) onto ball pin (2).  
 5.15 Screw pin nut (13) onto ball pin (2) then tighten to 175 lbs. ft. (237Nm.) torque.  
 5.16 Using a 2lb hammer, tap steering lever to 'Shock' ball pin (2) into taper hole.  
 5.17 Re-torque pin nut (13) to 175 lbs. ft. (237Nm)  
 5.18 Fit split pin (12), if slot / hole are not in line, adjust up to next slot.

Min pin nut torque 175 lbs. ft. (237Nm.). Max pin nut torque 200 lbs. ft. (271Nm)

- 5.19 Re-charge ball socket with Shell 'Retinax LX' or equivalent grease through lubricator (17).





**SECTION 6 REFITTING SWIVEL ASSEMBLY**

- 6.1 Prior to assembly, pack swivel pin bearing (20/20A) with lithium base grease (Shell Retinax LX or equivalent) using a bearing packer or manually knead grease between rollers, race and cage.
- 6.2 Coat all internal surfaces / parts with clean gear oil.
- 6.3 Fit swivel pin top oil seal (18), open side first, into position in top swivel bore (58).
- 6.4 Fit swivel pin bearing cup (20) into position in swivel bore (58).
- 6.5 Press swivel pin bottom bush (57) into position in swivel bore (58) flush with bottom face of swivel.
- 6.6 Fit swivel bush seal (52) onto the protruding diameter of swivel pin bottom bush (57) then place dirt excluder (78) into position over seal.
- 6.7 Position swivel assembly onto axle beam (37).

**Note :-** care must be taken during this operation so as not to roll or trap swivel bush seal (52).

Suggest a thin piece of card or plastic placed on seal during this operation.

Make sure that swivel pin bore is free of burrs and corrosion, then grease bore with multi purpose chassis grease.

- 6.8 Drive swivel pin (56) through swivel (58) and axle beam (37).
- 6.9 Lubricate swivel pin bearing sleeve (17) with clean oil / grease then fit over protruding swivel pin (56), large chamfer first to locate in oil seal bore (18) and abut axle bed (37).
- 6.10 Select swivel bearing adjustment shims (19) with a total thickness of approximately 0.020 " and place in position on top swivel bearing sleeve (37).
- 6.11 Fit swivel pin cone (20A) into swivel pin bearing cup (20)
- 6.12 Fit swivel pin washer (21) and swivel pin nut (22) then tighten nut to 500 - 700 lbs. ft. (678 - 949Nm.)
- 6.13 Using a 7/14 lb hammer, shock load axle beam (37) on forged end area.

SECTION 7 SWIVEL BEARING ADJUSTMENT

- 7.1 With nominal shim (19) thickness of 0.020 " placed between bearing (20/420A) and bearing sleeve (17), attach a cord and spring balance capable of reading 25 lbs (11 1/2 kg) to end of stub axle (58) as shown in fig. no. 6.  
Pull swivel from lock to lock, noting spring balance reading, ignoring the force needed to start movement. The correct reading should be between 12 to 24 lbs. (5.5 to 11kg.) pull giving 10 - 20 lbs ft. (13.6 - 27Nm.)  
If the reading is outside these limits, it will be necessary to alter shim thickness (39) between bearing cone (20A) and its sleeve (17).
- To increase the load required, remove shims from nominal pack.
- To decrease the force required, add shims to the nominal pack.
- Add or subtract shims as required until a reading of 10 - 20 lbs. ft. (13.6 - 27Nm.) is obtained.
- 7.2 When swivel is set correctly, check that swivel pin nut (22) is tightened to 500 - 700 lbs. ft. (678 - 949Nm.) torque .

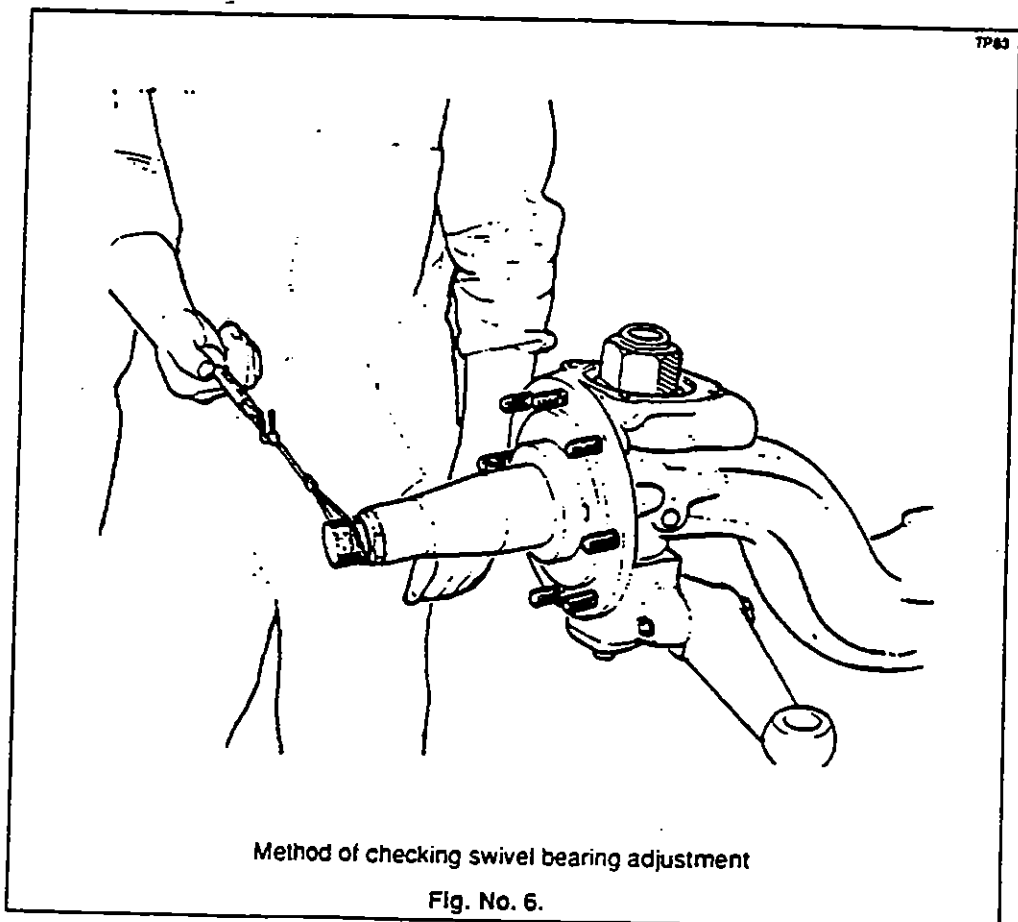



SECTION 8 SWIVEL FINAL ASSEMBLY

- 8.1 Apply a thin layer ( $\frac{1}{16}$ " - 1.5mm) of lithium base grease (Shell Retinax LX or equivalent) to the inside of swivel top cap (23).
- 8.2 Clean top cap and swivel mating faces (23 & 58) with Loctite Superclean Safety Solvent no.706 or other suitable chlorinated solvent then apply a complete  $\frac{1}{8}$ " bead of Loctite Superflex (black) around base of top cap (23) before fitting to swivel (58) within 5 minutes of applying Loctite. See fig. no.3
- 8.3 Secure top cap (23) with swivel top cap setscrews and washers ( 25 & 24) and tighten to 51 - 62 lbs. ft. (69 - 84Nm.).
- 8.4 Clean bottom cap and swivel mating faces (55 & 58) with Loctite Superclean Safety Solvent no.706 or other suitable chlorinated solvent then apply a complete  $\frac{1}{8}$ " bead of Loctite Superflex (black) around base of bottom cap (55) before fitting to swivel (58) within 5 minutes of applying Loctite. See fig. no.7

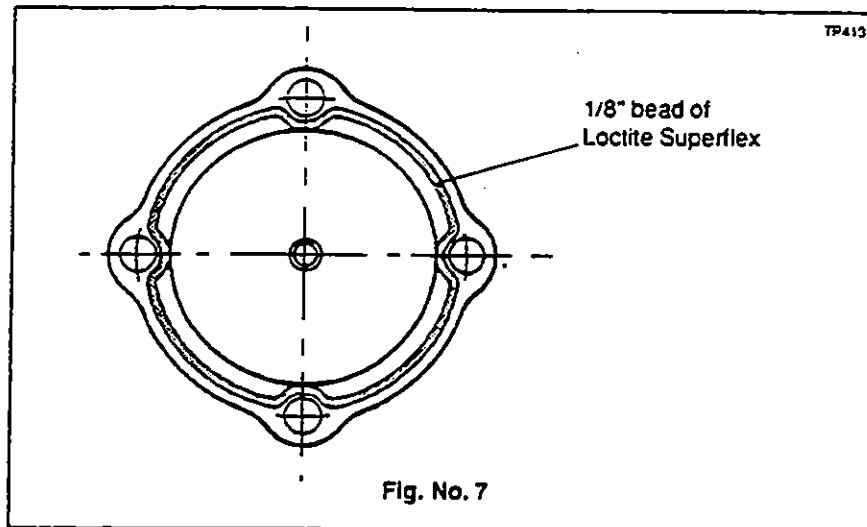

- 8.5 Secure bottom cap (55) with swivel bottom cap setscrews and washers (53 & 54) then tighten to 26 - 32 lbs. ft. (33 - 35Nm.).
- 8.6 Check tightening torque of bottom lever studs (50 & 51) is within limits of 190 - 210 lbs ft. (258 - 285Nm.).
- 8.7 Locate bottom steering lever (49) onto studs (50 & 51). then fit steering lever nuts (42) and tighten to 190 - 275 lbs. ft. (258 - 353Nm.).
- 8.8 Check that tightening torque of top steering lever studs (28) is between limits 190 - 210 lbs ft. (258 - 285Nm.).
- 8.9 Fit top steering lever (29) onto studs (28) then fit nuts (30) and tighten to 190 - 275 lbs.ft. (258 - 353Nm.).
- 8.10 Fit new lubricators (26 & 44) with protective caps (27 & 43) into their respective positions in swivel top cap (23) and bottom steering lever (49).

SECTION 8. SWIVEL FINAL ASSEMBLY Cont.

- 8.12 Charge swivel assembly with grease.  
Swivel is full when grease seeps from between upper face of axle beam (37) and swivel jaw (58) in top half (see fig. no. 8) and from between swivel oil seal (56) and lower face of axle beam (37) (see fig. no.9).

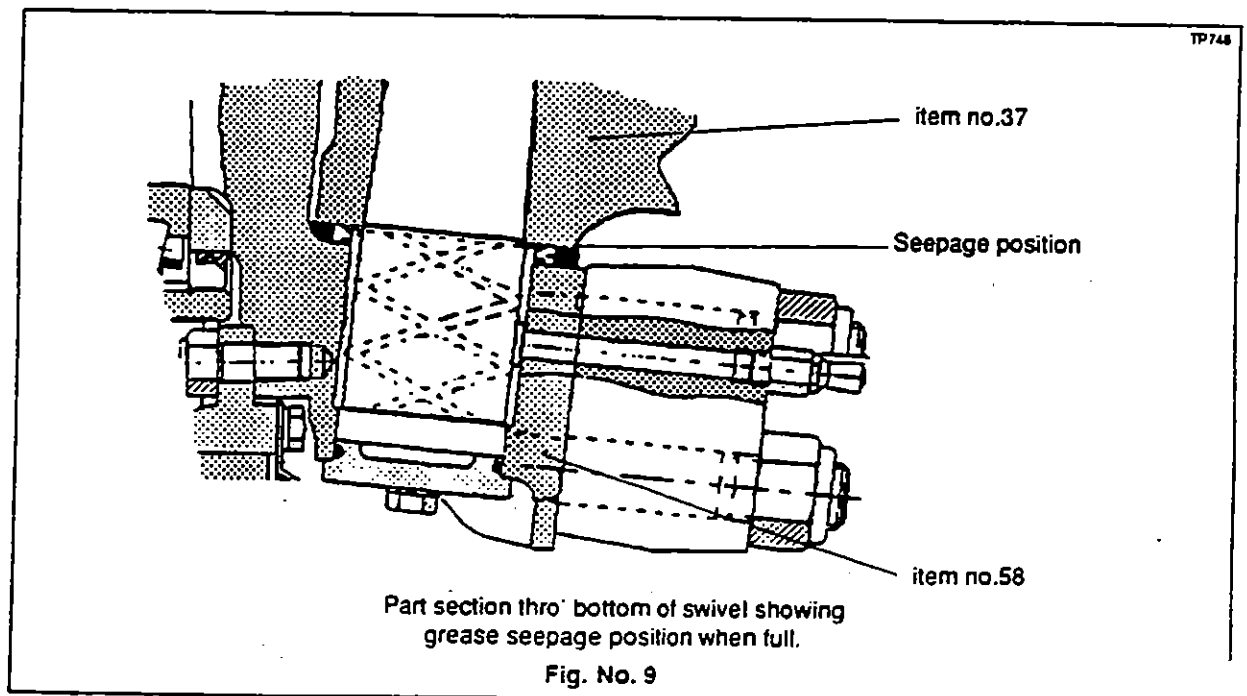
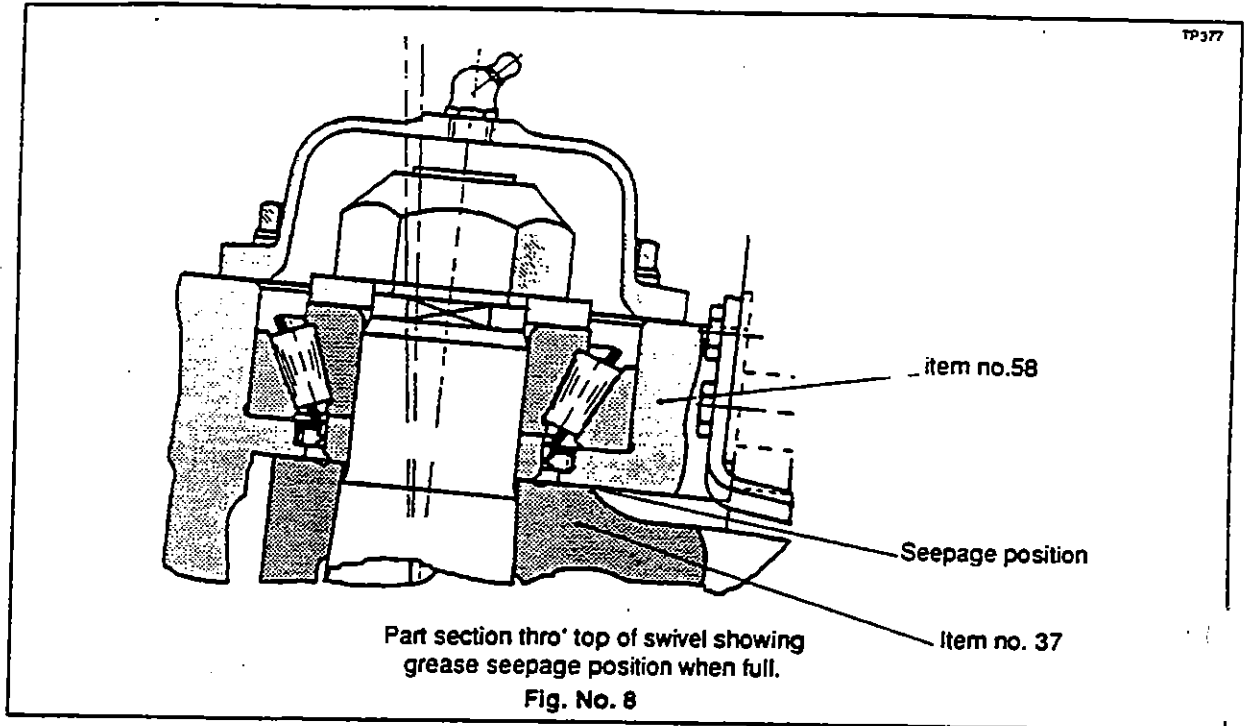

- 8.13 Reconnect ball socket and tie rod (39 & 38) to steering lever (49).

Note :- Ball pin (39) and ball pin tapers in bottom steering levers (49) must be clean, dry and free from oil prior to assembly.

**SECTION-9 TO ASSEMBLE THE HUB**

Prior to assembly, pack hub bearing (11/11A & 64/64A) with lithium base grease (Shell Retinax LX or equivalent) using a bearing packer or manually knead grease between rollers, race and cage.

- 9.1 Fit hub bearing distance piece (60) onto swivel stub axle (58).
- 9.2 Fit inner and outer hub bearing cups (11 & 64) onto their bores in hub (8).
- 9.3 Fill hub cavity with lithium base grease (Shell Retinax LX or equivalent) from outer bearing shoulder to centre line of inner bearing cone as shown in figure no.10.

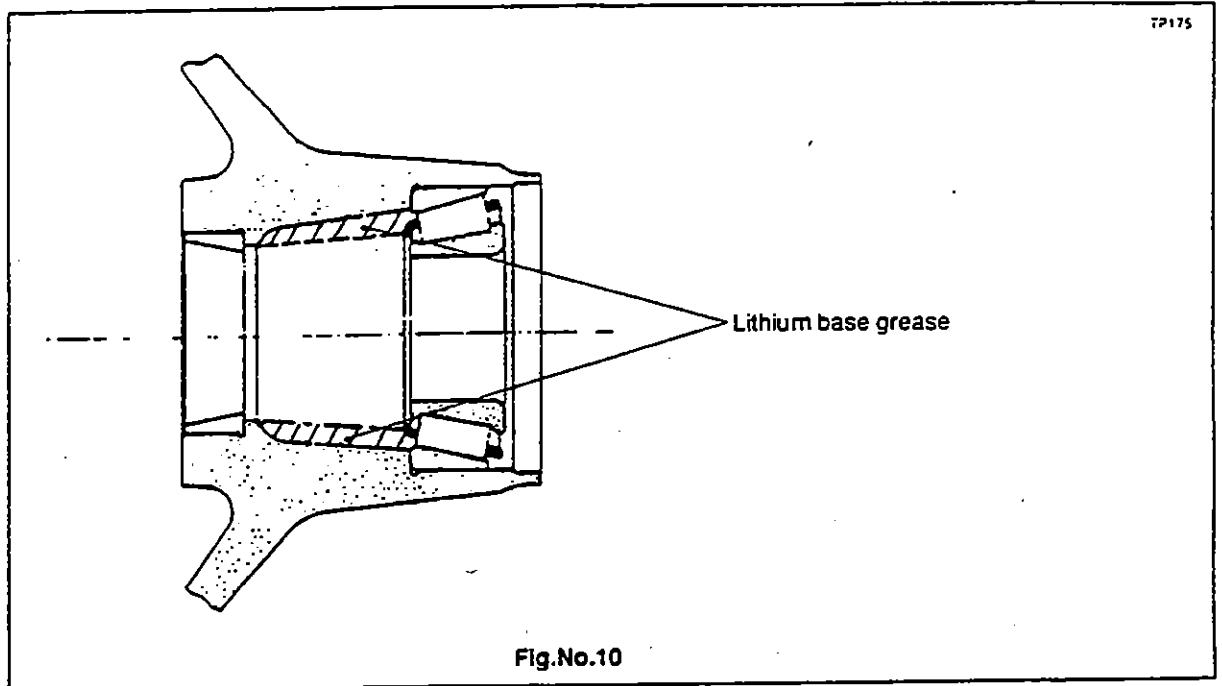

**Fig.No.10**

- 9.4 Fit inner hub bearing cone (11A) into its cup in hub (8).
- 9.5 Press hub oil seal (12) into position in hub (8) using a suitable bumper tool which locates on outer part of seal to prevent damage on assemble.
- 9.6 Fit hub assembly onto swivel stub axle (58).
- 9.7 Fit outer bearing cone (64A) into its cup (64).
- 9.8 Fit hub bearing washer and hub bearing nut (6 & 67). Tighten nut hard with the aid of a small tommy bar just enough to take up bearing slack.
- 9.9 Fit hub bearing nut pinch bolt and nut (66 & 5), tighten finger tight.



SECTION 9 TO ASSEMBLE THE HUB Cont.

- 9.10 Adjust hub 'End Float' as follows :-  
Rotate hub and using a hide faced mallet, knock hub backwards and forwards along axle arm to 'Shock Load' and thus settle bearings in position.

Note :- It is very important to rotate and ' shock load ' the hub because :-

- a) The rotation serves to ensure that bearing rollers settle into running in their correct tracks.
- b) The ' Shock Load ' is to ensure that bearings are seated correctly up to their abutment shoulders.

Test the tightness of hub bearing nut (67), if loose, re-tighten hard.

Rotate and ' Shock Load ' the hub again.

Continue this procedure until hub bearing nut (67) cannot be tightened further after hub has been rotated and ' Shock Loaded '.

Back off hub bearing nut (67) by approximately 30° then rotate again and knock hub outward along axle arm to release bearings.

Mount a dial indicator on hub flange (8) and position its pointer on end of axle stub ( see fig. no. 11.).

Rock the hub backwards and forwards along axle arm, taking a reading on dial indicator.

The correct ' End Float ' is between limits 0.0005 " to 0.002 " (0.013 to 0.050 mm).

Tighten the hub bearing pinch bolt nut (5) to 24 - 26 lbs ft. (33 - 35Nm.).

Check the ' End Float ' again, using above procedure, and adjust if outside specified limits.

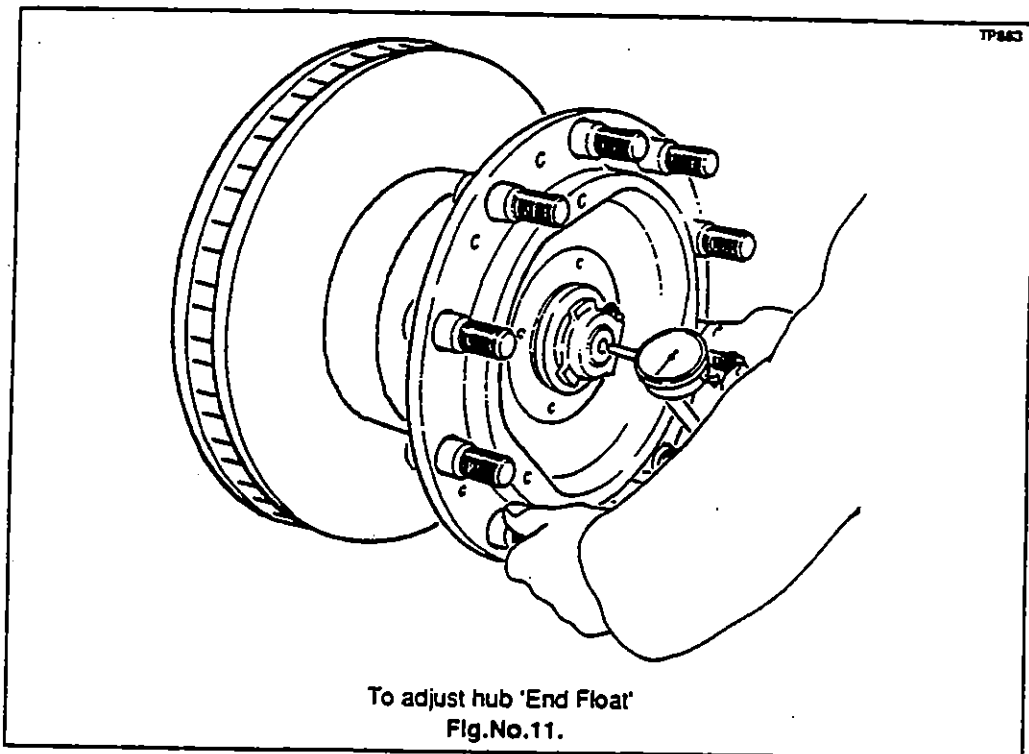

SECTION 9 TO ASSEMBLE THE HUB Cont.

- 9.11 Smear the inside of hub cap (3) with a thin coating of grease as indicated in lubrication section A, page no.A3.
- 9.12 Clean hub cap and hub mating faces (3 & 8) with Loctite Superclean Safety Solvent no.706 or other suitable chlorinated solvent then apply a complete 1/8" bead of Loctite Superflex (black) around mating face of hub cap (3). See fig. no. 12.

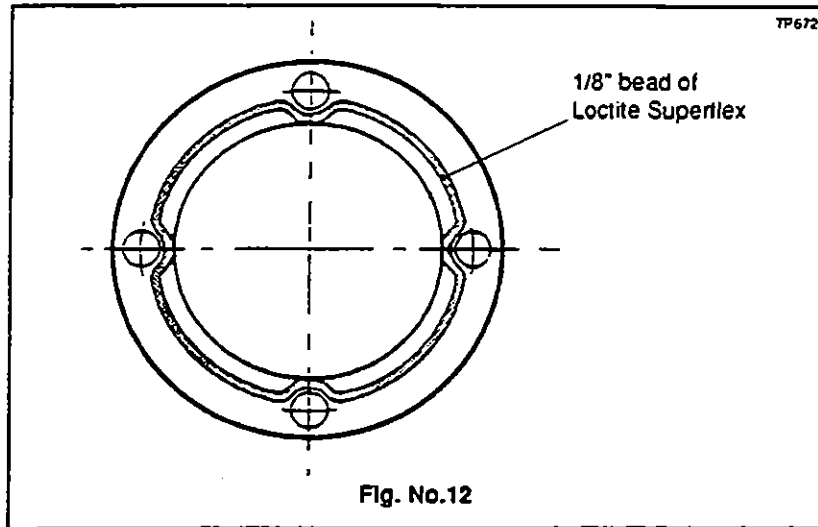

- 9.13 Fit hub cap along (3) within 5 minutes of applying sealant then secure with hub cap setscrews and washers (1 & 2) tightening setscrews to 85 - 103 lbs. ft. (115 - 140Nm.).

SECTION 10 FINAL ASSEMBLY

- 10.1 Refit road wheels, securing with wheel nuts (7 posn.).  
Tighten nuts to 475 - 525 lbs. ft. (644 - 712 Nm).
- 10.2 Check axle supports then lower vehicle to ground.
- 10.3 Remove chocks and jacks.
- 10.4 Check wheel alignment as follows:-  
Set the wheels in a straight ahead position, and at points level with wheel centre, measure distance between edges of wheel rims both in front and behind axle centre.  
For correct alignment the front measurements should be 0" to  $\frac{1}{32}$ " smaller than that of rear ie. 'Toe In' to allow for inaccuracies in the wheels, the same checks should be made with vehicle moved so that wheels have moved a further half a revolution (see fig. no.13)  
Adjust if required by slackening ball joint clamp bolts and rotating track rod tube.

DO NOT forget to re-tighten the clamp bolts to 51 - 62 lbs. ft. (69 - 84Nm.) after adjusting.

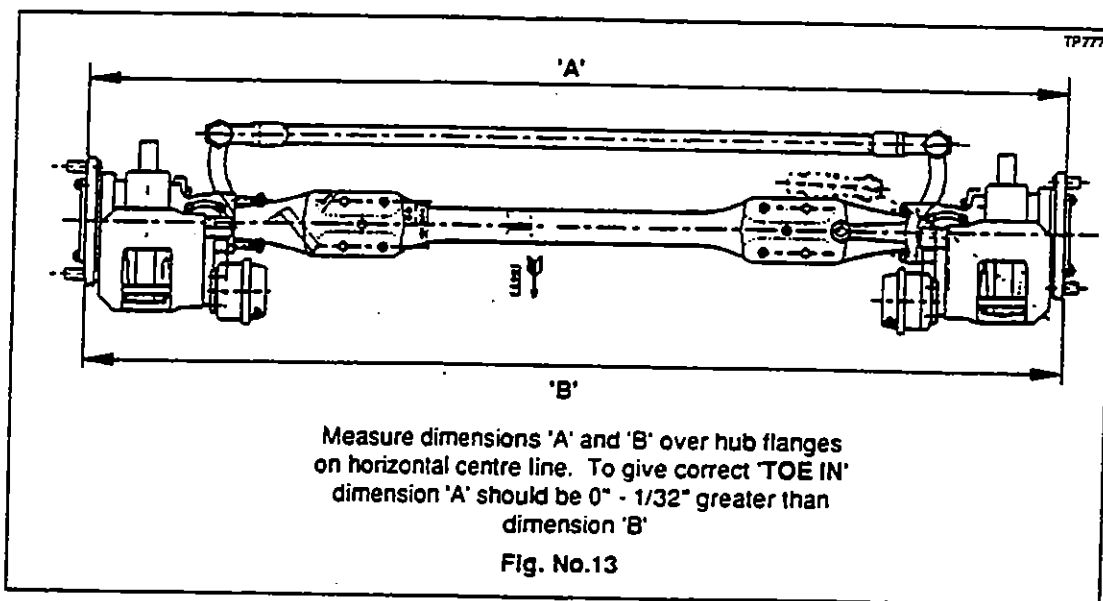



**TORQUE TABLE FOR S 82 STEER AXLE WITH KNORR AIR DISC BRAKE**

Item No	Description	Torque
1	Hub cap setscrew	85 - 103 lbs ft (115 - 140 Nm)
5	Hub pinch bolt nut	24 - 26 lbs ft (33 - 35 Nm)
7	Wheel nut	475 - 525 lbs. ft. (644 - 712 Nm)
16	Brake caliper setscrew	310 - 340lbs. ft. (420 - 461Nm.)
22	Swivel pin nut	500 - 700lbs.ft. (678 - 949Nm.)
25	Top cap setscrew	51 - 62 lbs. ft. (69 - 84 Nm)
28	Top Lever stud	190 - 210 lbs. ft. (258 - 285 Nm)
30	Top Lever nut	190 - 275 lbs. ft. (258 - 373 Nm)
31	Caliper bracket nut	85 - 103lbs.ft. (115 - 140Nm.)
42	Bottom lever nut	190 - 275 lbs ft (258 - 373 Nm)
47	Ball socket nut	100 - 170 lbs ft (136 - 231Nm)
50 & 51	Bottom lever stud	190 - 210 lbs ft (258 - 285 Nm)
53	Bottom cap setscrew	26 - 32 lbs ft (35 - 43 Nm)
59	Caliper bracket stud	51 - 62lbs. ft. (69 - 84Nm.)
62	Caliper bracket nut	85 - 103lbs.ft. (115 - 140Nm.)



PARTS LIST FOR S82 STEER AXLE (WITH KNORR DISC BRAKE)  
CUSTOMER PREVOST

AXLE ASSEMBLY No.2554.

ILLUSTRATION No.F47

Item No	Description	Qty.Per Axle	Part No.	Recommended Spares Holding Per		
				25 Axles	50 Axles	100 Axles
1	Hub cap setscrew	8	ML6012/35S	8	8	16
2	Hub cap spring washer	8	ML5712/1	8	8	16
3	Hub cap	2	F4651/29	2	4	6
4	Hub cap 'O' ring	2	R9434/149	2	2	4
5	Bearing nut pinch nut	2	SL228/4	2	4	6
6	Hub bearing 'D' washer	2	7786/30	2	4	6
7	Wheel stud protective cover	20	R9855/161			
8	Hub	2	F4651/28	2	4	6
9	Wheel stud RH	10	F4561/75	30	60	120
	Wheel stud LH	10	F4561/76	30	60	120
10	Pole wheel	2	F4651/100	2	4	6
11	Hub outer bearing cup	2	SL289/107	4	8	16
11A	Hub outer bearing cone	2	SL289/286	4	8	16
12	Hub oil seal	2	7786/32	4	8	16
13	Brake caliper RH	1	SM486/2K	1	2	3
	Brake caliper LH	1	SM486/3K	1	2	3
14	Caliper mounting bracket RH	1	F4651/86	1	2	3
	Caliper mounting bracket LH	1	F4651/87	1	2	3
15	Brake caliper retaining washer	12	N70040	12	12	24
16	Brake caliper retaining bolt	12	N70251	12	12	24
17	Swivel pin bearing sleeve	2	7662/19	2	4	6
18	Swivel pin oil seal	2	F4350/32	4	8	16
19	Adjusting shim (0.005")	min	4493/119	6	12	24
	Adjusting shim (0.010")	as	4493/119A	6	12	24
	Adjusting shim (0.015")	reqd	4493/119B	6	12	24
	Adjusting shim (0.008")	-	4493/119D	6	12	24
	Adjusting shim (0.006")	-	4493/119E	6	12	24
20	Swivel bearing cup	2	SL289/47	4	8	16
20A	Swivel bearing cone	2	SL289/48	4	8	16
21	Swivel pin 'D' washer	2	7433/30	2	4	6
22	Swivel pin nut	2	F4330/15	2	4	6
23	Top cap	2	F4561/16	2	4	6
24	Top cap setscrew spring washer	8	SL241/5	8	8	16
25	Top cap setscrew	8	SL554/4	8	8	16
26	Lubricator	2	SL1000/1	2	2	4
27	Lubricator protective cap	2	SL1000/76	2	2	4
28	Top steering lever stud LH	2	SL778/11	2	2	4
	Top steering lever stud RH	2	SL778/21	2	2	4
29	Top lever (LH)	1	F4651/9	1	2	3
30	Top lever nut	4	SL222/9	4	4	8
31	Brake caliper bracket nut	6	SL228/6	6	6	12
32	Stop screw adjusting washer	as	SL246/151	6	12	24
	Stop screw adjusting washer	reqd	SL246/152	6	12	24
	Stop screw adjusting washer	-	SL246/153	6	12	24
	Stop screw adjusting washer	-	SL246/269	6	12	24
33	Swivel stop screw LH	1	7903/44A	1	2	3
	Swivel stop screw RH	2	7903/44G	2	4	6
34	Supplied within item 58					
35 & 36	Not required on this application					
37	Axle bed	1	F4651/1	1	2	3
38	Tie rod (assy with itm 39 - 25632/1)	1	F4560/12			
39	Socket assembly	1	25630			
	Socket assembly	1	25631			
40	Lubricator	2	SL1000/1	2	2	4
41	Lubricator protective cap	2	SL1000/76	2	2	4
42	Steering lever stud nut	4	SL222/9	4	4	8



PARTS LIST FOR S82 STEER AXLE (WITH KNORR DISC BRAKE)

AXLE ASSEMBLY No.25546

ILLUSTRATION No.F47

Item No	Description	Qty.Per Axle	Part No.	Recommended Spares Holding Per		
				25 Axles	50 Axles	100 Axles
43	Lubricator protective cap	2	SL1000/76	2	2	4
44	Lubricator	2	SL1000/1	2	2	4
45	Lubricator extension	2	SL1000/31	-	-	2
46 - 48	Supplied within item 39					
49	Bottom lever RH	1	F4651/7	1	2	3
	Bottom lever LH	1	F4651/8	1	2	3
50	Steering lever stud - long	2	SL778/18	2	2	4
51	Steering lever stud - short	2	SL778/13	2	2	4
52	Swivel pin seal (upper) ('V' ring)	2	LS1060/64A	6	12	24
53	Bottom cap setscrew	4	SL553/4	4	4	8
54	Spring washer	4	SL242/4	4	4	8
55	Swivel bottom cap	2	5430/34	2	4	6
56	Swivel pin	2	7786/14	2	4	6
57	Swivel pin bottom bush	2	7786/20	2	4	6
58	Swivel assembly LH	1	SF4651/2	1	2	3
	Swivel assembly RH	1	SF4651/3	1	2	3
59	Brake caliper bracket stud	10	SL785/110	10	10	20
60	Hub bearing distance piece	2	7816/26	2	4	6
61	Brake caliper bracket bolt	6	SL795/68	6	6	12
62	Brake caliper bracket nut	10	SL228/6	10	10	20
63	Brake disc	2	F4651/88	2	4	6
64	Hub Inner bearing cup	2	SL289/293	4	8	16
64A	Hub Inner bearing cone	2	SL289/294	4	8	16
		Kit no. 17899/2				
65	Brake disc capscrew	20	ML7916/50X	20	20	40
66	Bearing nut pinch bolt	2	SL553/17	2	4	6
67	Hub bearing nut	2	7786/77A	2	4	6



## **Notes**

Drawn by D. J. Highton February '94

Annotations relevant to Tightening Torque Table

Tightening Torque			
Item Numbers	Lbs ft	Nm	Item Numbers
1-31, 62	85/103	115/140	190/210
5	24/26	33/35	30/42
16	310/340	420/460	47
22	500/700	678/949	53
25, 59	51/62	69/84	65
			295/325
			400/441

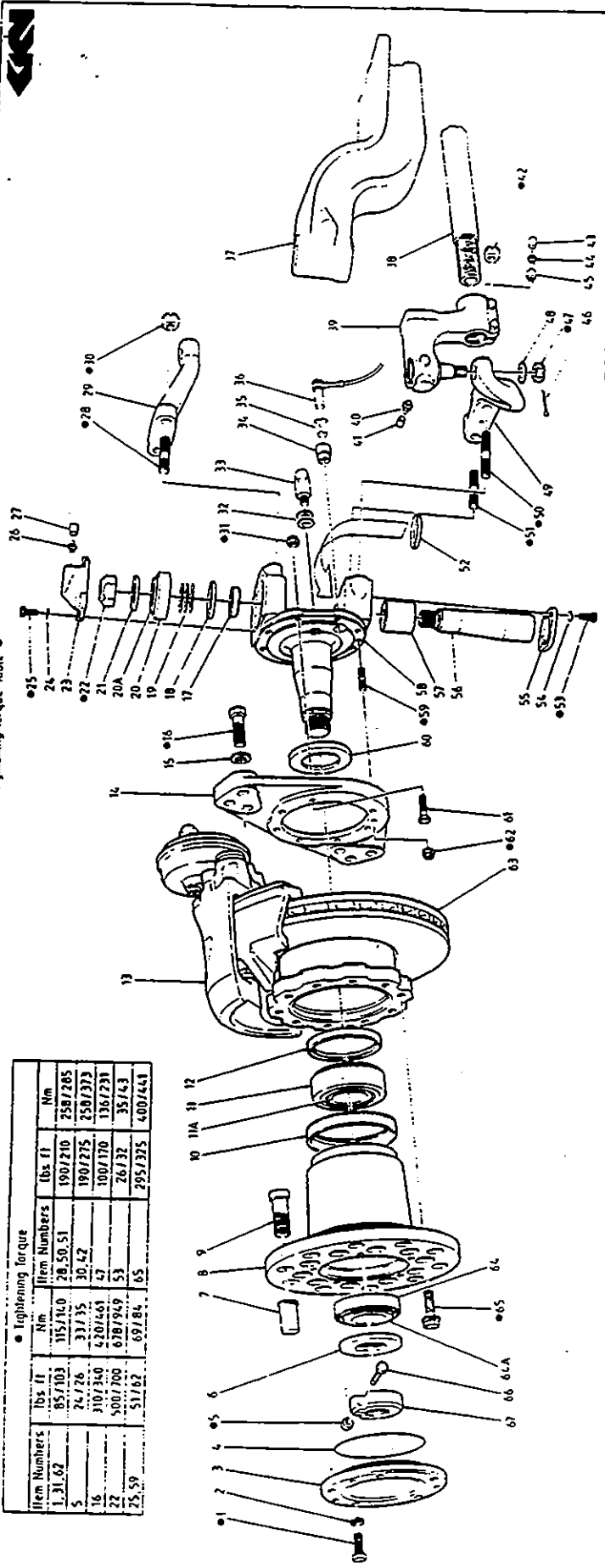

S82 DEAD STEER HUB UNIT

Illustration No 147

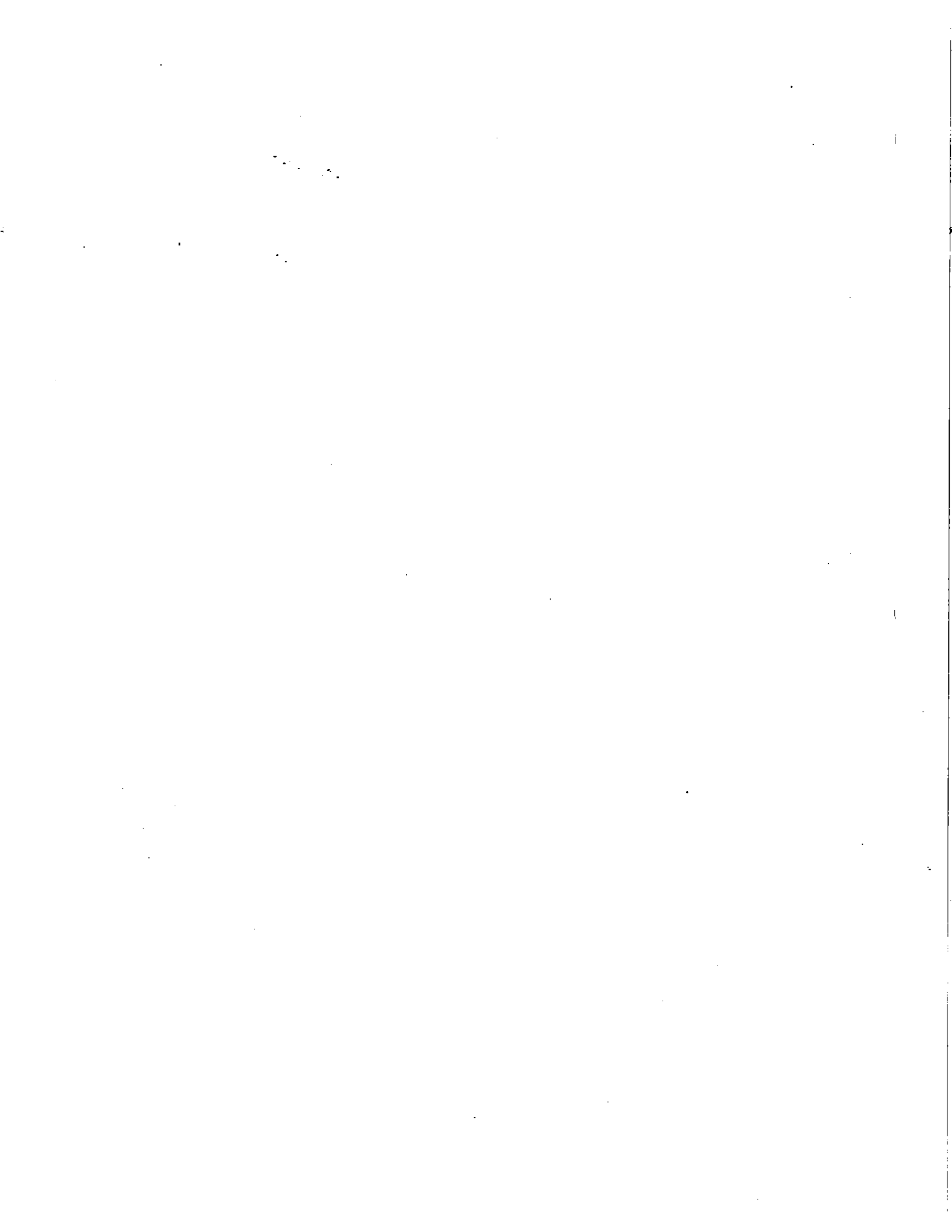



**Axles Ltd. Kirkstall Division - Technical Publications**

**PARTS AND SERVICE INSTRUCTIONS FOR TS5 HUB UNIT  
WITH KNORR AIR DISC BRAKE**

**ILLUSTRATION No.H86**

**MANUAL SECTION C**



**PARTS AND SERVICE INSTRUCTIONS FOR TYPE TSS HUB UNIT**

**DESCRIPTION**

The hub unit consists of a stub axle fitted with Knorr air disc brakes.

The hub taper roller bearings are of a generous size and, adjusted by means of a special split nut with pinch bolt arrangement.

**SECTION 1 ROUTINE MAINTENANCE**

**1.1 Hub bearing adjustment**

- a) An inspection should be made after the first 3,000 miles (4,800 km) and then at intervals of 25,000 miles (40,000km). With the wheels raised they should revolve quite freely without roughness.
- b) Hub bearings should have a slight end float movement within the limits 0.0005" to 0.002" when rocked forwards and backwards on axle stub. See section 8, page B9 if any adjustment is required.

**SECTION 2 TO REMOVE HUB UNIT**

- 2.1 Chock the appropriate wheels.
- 2.2 Whilst road wheels are still on ground, loosen wheel nuts (7 posn.) slightly.
- 2.3 Raise vehicle, remove road wheel nuts and remove road wheels.
- 2.4 Disconnect air line from brake caliper (12).
- 2.5 Remove brake caliper setscrews with washers (15 & 14) then lift off brake caliper assembly (12).
- 2.6 Remove hub cap setscrews and washers (1 & 2).
- 2.7 Remove hub cap (3) with 'O' ring (4) then discard 'O' ring.
- 2.8 Remove hub bearing pinch bolt nut (5) and bolt (26), then remove hub bearing nut (27) along with hub bearing washer (6).
- 2.9 Remove hub (8) complete with its bearings (11/11A & 24/24A) and oil seal (12) then lift off outer bearing cone (24A).
- 2.10 Remove oil seal (12) and inner bearing cone (11A) from hub (8) .
- 2.11 Drive out hub bearing cups (11 & 24) from hub (8).
- 2.12 If hub bearing distance piece (oil seal wear sleeve) (16) shows signs of wear or corrosion it must be removed and replaced with a new part.





**SECTION 3 TO ASSEMBLE THE HUB**

Prior to assembly, pack hub bearing (11/11A & 24/24A) with lithium base grease (Shell Retinax LX or equivalent) using a bearing packer or manually knead grease between rollers, race and cage.

- 3.1 Fit hub bearing distance piece (16) onto swivel stub axle (17).
- 3.2 Fit inner and outer hub bearing cups (11 & 24) onto their bores in hub (8).
- 3.3 Fill hub cavity with lithium base grease (Shell Retinax LX or equivalent) from outer bearing shoulder to centre line of inner bearing cone as shown in figure no.1.

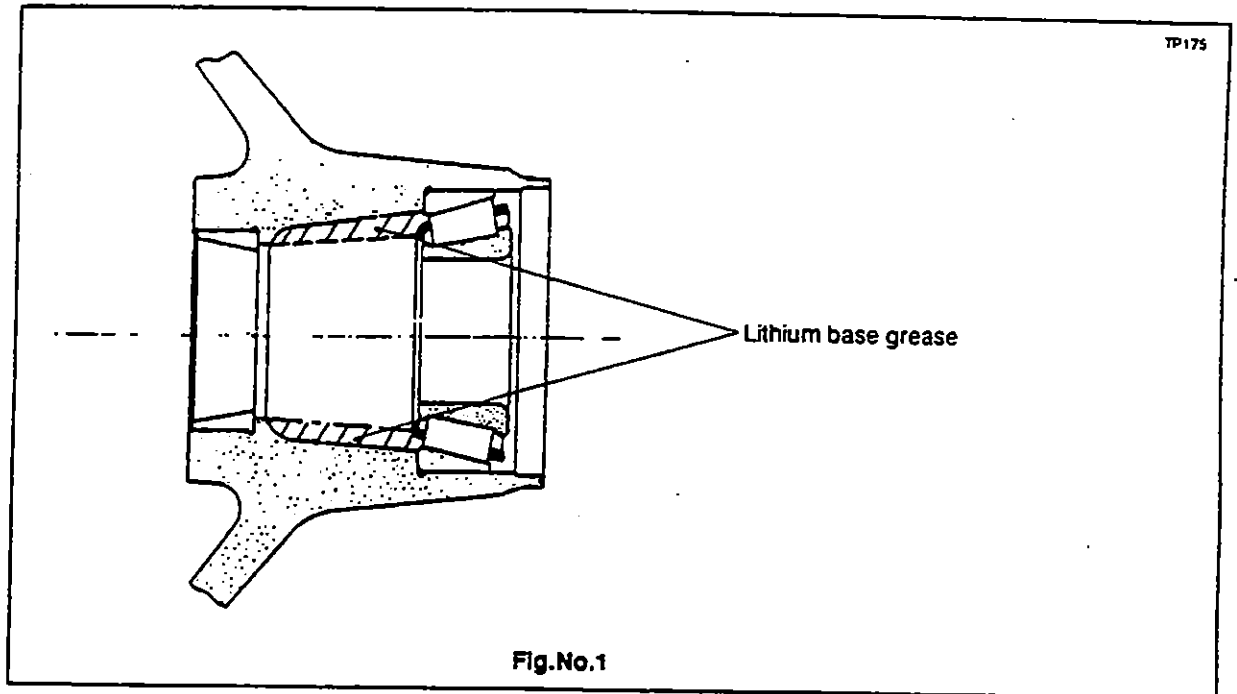

- 3.4 Fit inner hub bearing cone (11A) into its cup in hub (8).
- 3.5 Press hub oil seal (12) into position in hub (8) using a suitable bumper tool which locates on outer part of seal to prevent damage on assemble.
- 3.6 Fit hub assembly onto swivel stub axle (17).
- 3.7 Fit outer bearing cone (24A) into its cup (24).
- 3.8 Fit hub bearing washer and hub bearing nut (6 & 27). Tighten nut hard with the aid of a small tommy bar just enough to take up bearing slack.
- 3.9 Fit hub bearing nut pinch bolt and nut (26 & 5), tighten finger tight.

SECTION 3 TO ASSEMBLE THE HUB Cont.

- 3.10 Adjust hub 'End Float' as follows :-  
Rotate hub and using a hide faced mallet, knock hub backwards and forwards along axle arm to 'Shock Load' and thus settle bearings in position.

Note :- It is very important to rotate and ' shock load ' the hub because :-

- a) The rotation serves to ensure that bearing rollers settle into running in their correct tracks.
- b) The ' Shock Load ' is to ensure that bearings are seated correctly up to their abutment shoulders.

Test the tightness of hub bearing nut (27), if loose, re-tighten hard.

Rotate and ' Shock Load ' the hub again.

Continue this procedure until hub bearing nut (27) cannot be tightened further after hub has been rotated and ' Shock Loaded '.

Back off hub bearing nut (27) by approximately 30° then rotate again and knock hub outward along axle arm to release bearings.

Mount a dial indicator on hub flange (8) and position its pointer on end of axle stub ( see fig. no. 2.).

Rock the hub backwards and forwards along axle arm, taking a reading on dial indicator.

The correct ' End Float ' is between limits 0.0005 " to 0.002 " (0.013 to 0.050 mm).

Tighten the hub bearing pinch bolt nut (5) to 24 - 26 lbs ft. (33 - 35Nm.).

Check the ' End Float ' again, using above procedure, and adjust if outside specified limits.

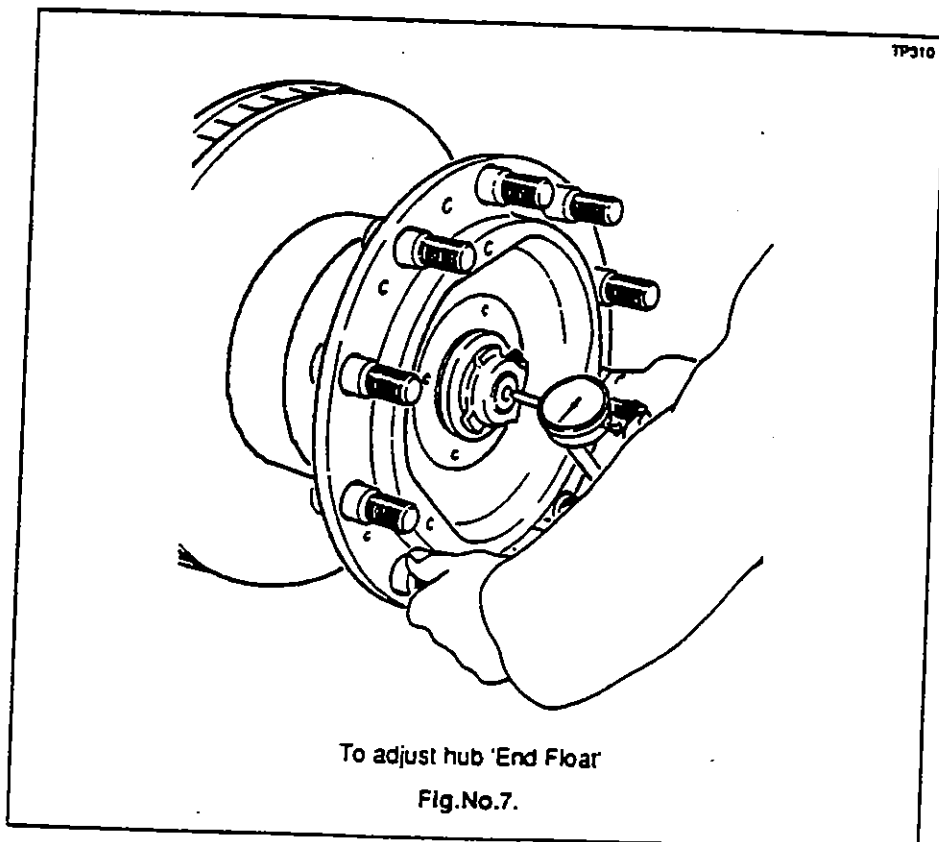



**SECTION 3 TO ASSEMBLE THE HUB Cont.**

- 3.11 Smear the inside of hub cap (3) with a thin coating of grease as indicated in lubrication section A, page no.A3.
- 3.12 Clean hub cap and hub mating faces (3 & 8) with Loctite Superclean Safety Solvent no.706 or other suitable chlorinated solvent then apply a complete 1/8" bead of Loctite Superflex (black) around mating face of hub cap (3). See fig. no. 3.

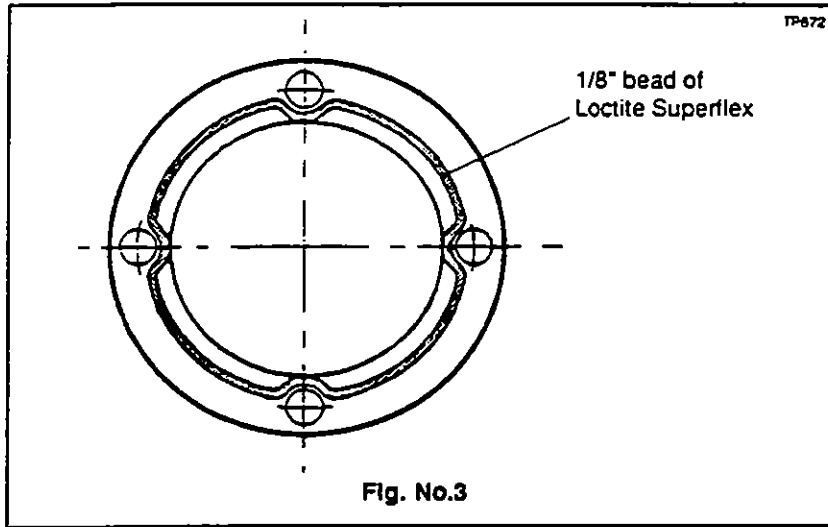

- 3.13 Fit hub cap along (3) within 5 minutes of applying sealant then secure with hub cap setscrews and washers (1 & 2) tightening setscrews to 85 - 103 lbs. ft. (115 - 140Nm.).

**SECTION 4 FINAL ASSEMBLY**

- 4.1 Refit road wheels, securing with wheel nuts (7 posn.).  
Tighten nuts to 475 - 525 lbs. ft. (644 - 712 Nm).
- 4.2 Lower vehicle to ground.
- 4.3 Remove chocks and jacks.

## TORQUE TABLE FOR TS5 HUB UNIT WITH KNORR AIR DISC BRAKE

Item No	Description	Torque
1	Hub cap setscrew	85 - 103 lbs ft (115 - 140 Nm)
5	Hub pinch bolt nut	24 - 26 lbs ft (33 - 35 Nm)
7	Wheel nut	475 - 525 lbs. ft. (644 - 712 Nm)
15	Brake caliper setscrew	310 - 340lbs. ft. (420 - 461Nm.)
18	Axle stub stud	95 - 105lbs.ft. (129 - 142Nm.)
20	Axle Stub nut	210 - 256lbs.ft. (285 - 347Nm.)
21	Caliper bracket nut	85 - 103lbs.ft. (115 - 140Nm.)
22	Caliper bracket nut	85 - 103lbs.ft. (115 - 140Nm.)
59	Caliper bracket stud	51 - 62lbs. ft. (69 - 84Nm.)



**PARTS LIST FOR TS5 HUB UNIT (WITH KNORR DISC BRAKE)**

**CUSTOMER PREVOST**

**AXLE ASSEMBLY No.33537**

**ILLUSTRATION No. H86**

Item No	Description	Qty. Per Axle	Part No.	Recommended Spares Holding Per		
				25 Axles	50 Axles	100 Axles
1	Hub cap setscrew	8	ML6012/35S	8	8	16
2	Hub cap spring washer	8	ML5712/1	8	8	16
3	Hub cap	2	F4651/29	2	4	6
4	Hub cap 'O' ring	2	R9434/149	2	2	4
5	Bearing nut pinch nut	2	SL228/4	2	4	6
6	Hub bearing 'D' washer	2	7786/30	2	4	6
7	Wheel stud protective cover	20	R8484/161			
8	Hub	2	F4651/28	2	4	6
9	Wheel stud RH	10	F4561/75	30	60	120
	Wheel stud LH	10	F4561/76	30	60	120
10	Hub Inner bearing cup	2	SL289/293	4	8	16
10A	Hub Inner bearing cone	2	SL289/294	4	8	16
11	Hub oil seal	2	7786/32	4	8	16
12	Brake caliper RH	1	SM486/4K	1	2	3
	Brake caliper LH	1	SM486/5K	1	2	3
13	Caliper mounting bracket	2	R9855/65	2	4	6
14	Brake caliper retaining washer	12	N70040	12	12	24
15	Brake caliper retaining bolt	12	N70251	12	12	24
16	Hub bearing distance piece	2	7816/26	2	4	6
17	Axle stub	1	R9855/238	1	2	3
18	Chassis mounting stud	16	SB6416/42V	16	16	32
19	Chassis mounting washer	16	ML5716/1	16	16	32
20	Chassis mounting nut	16	ML5016/X	16	16	32
21	Brake caliper bracket stud	16	SL785/110	16	16	32
22	Brake caliper bracket nut	16	SL228/6	16	16	32
23	Brake disc	2	F4651/88	2	4	6
24	Hub outer bearing cup	2	SL289/107	4	8	16
24A	Hub outer bearing cone	2	SL289/286	4	8	16
25	Brake disc capscrew	20	ML7916/50X	20	20	40
26	Bearing nut pinch bolt	2	SL553/17	2	4	6
27	Hub bearing nut	2	7786/77A	2	4	6

Kit no.  
17899/2

Kit no.  
17899/1



## **Notes**



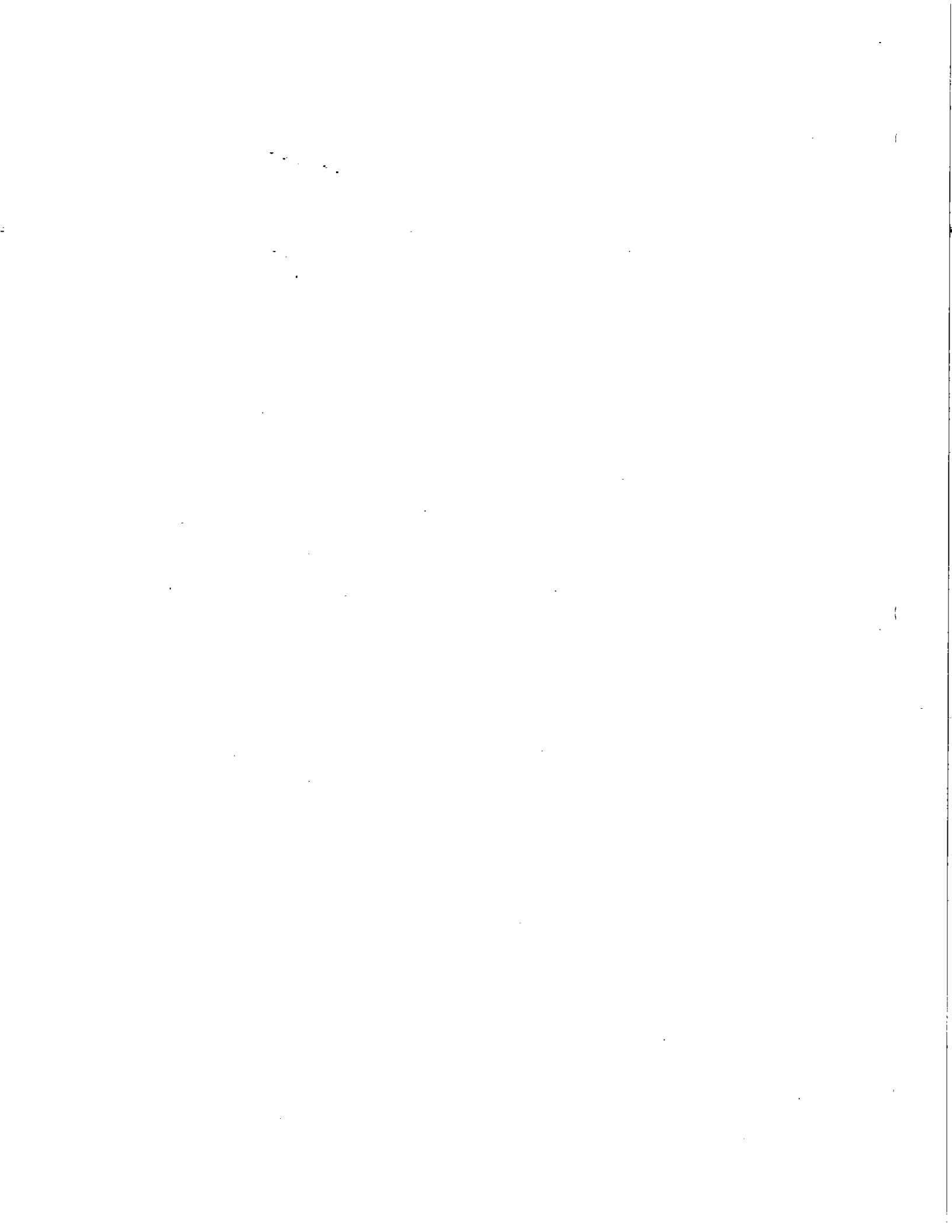



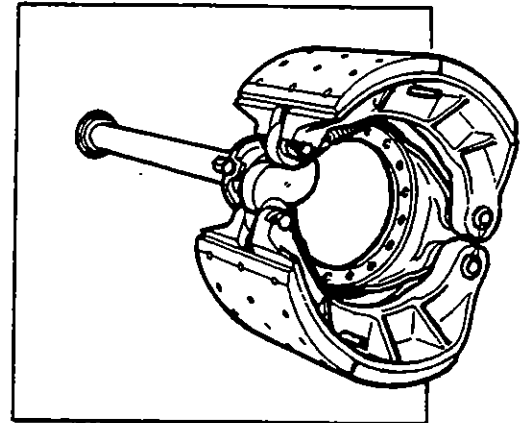
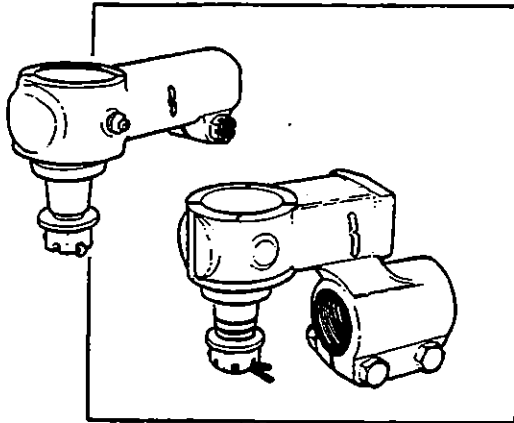
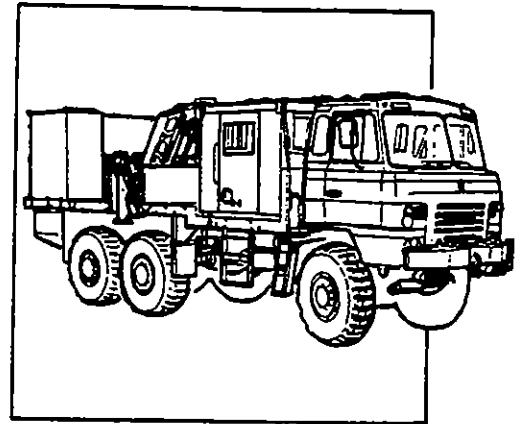
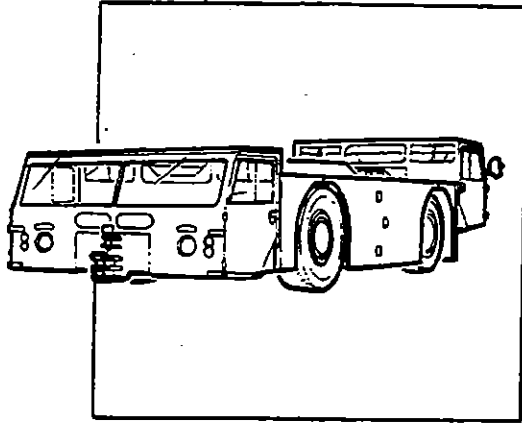

---

# GKN AXLES LIMITED

## KIRKSTALL DIVISION

Abbey Road · Kirkstall · Leeds LS5 3NF · England

Tel: 0532 584611

Telex: 55109

Facsimile No 0532 586097 (CCIT G3)

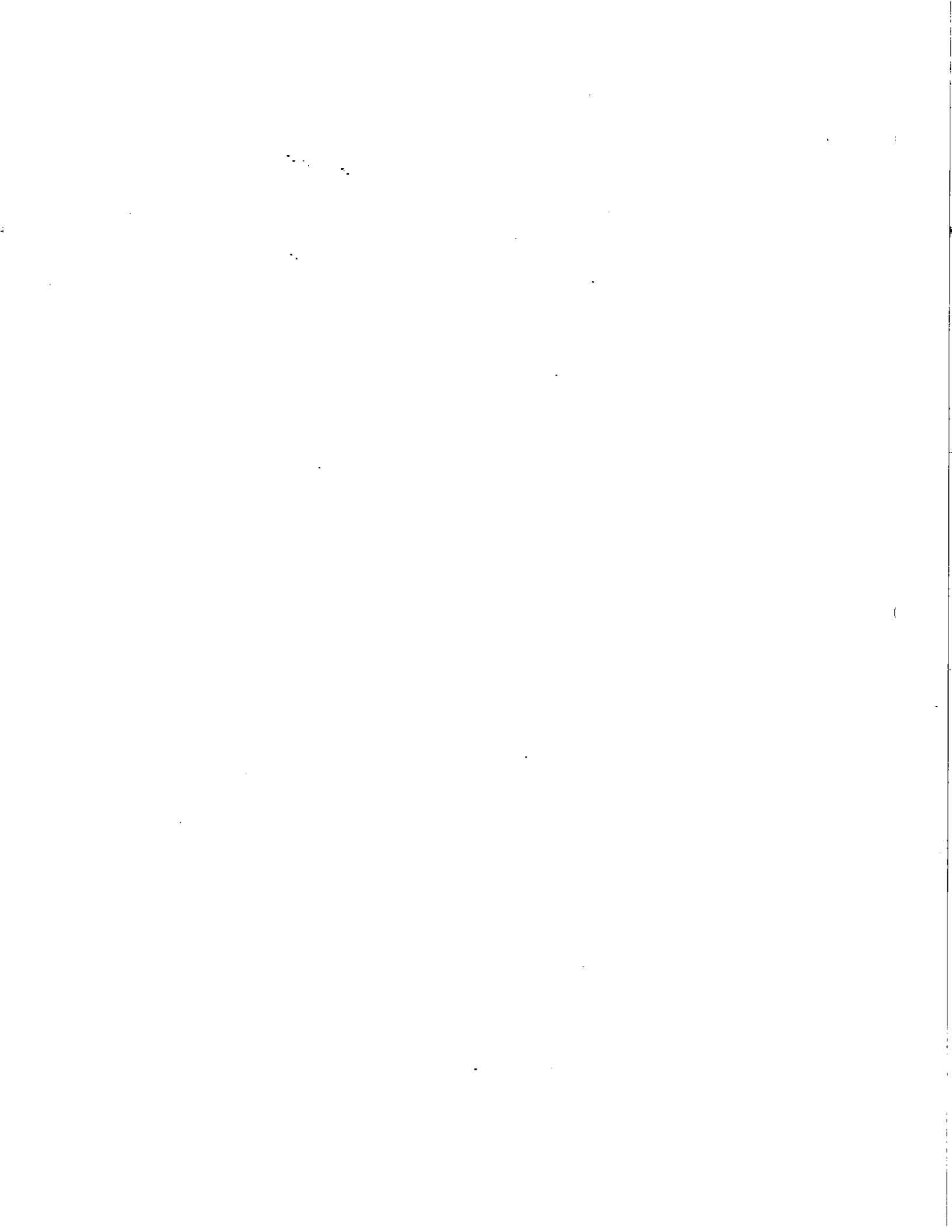

# SECTION 11: REAR AXLES

---

## CONTENTS

1. DRIVE AXLE .....	2
1.1 Description .....	2
1.2 Drive Axle Lubrication .....	2
1.3 Maintenance .....	2
1.3.1 Checking and Adjusting the Oil Level .....	2
1.3.2 Draining and Replacing the Oil .....	3
1.3.3 Differential Oil Sensor (If applicable) .....	3
1.4 Removal and Replacement .....	3
1.4.1 Removal .....	3
1.4.2 Replacement .....	4
1.5 Disassembly and reassembly .....	4
1.6 Gear Set Identification .....	4
1.7 Adjustments .....	4
1.8 Fastener Torque Chart .....	4
1.9 Tire Matching .....	4
1.10 Drive Axle Alignment .....	5
1.10.1 Description .....	5
1.10.2 Procedure .....	5
2. TAG AXLE .....	6
2.1 Description .....	6
2.2 Lubrication .....	7
2.3 Removal and Replacement .....	7
2.3.1 Removal .....	7
2.3.2 Replacement .....	7
2.4 Tag Axle Alignment .....	8
2.4.1 Description .....	8
2.4.2 Procedure .....	8
3. SPECIFICATIONS .....	10

## Section 11: REAR AXLES

### 1. DRIVE AXLE

#### 1.1 Description

The Rockwell drive axle is equipped with a single reduction standard carrier mounted in front of the axle housing. The carrier has a hypoid drive pinion, a ring gear set and gears in the differential assembly.

A straight roller bearing (spigot) is mounted on the head of the drive pinion. All other bearings in the carrier are tapered roller bearings. When the carrier operates, there is a normal differential action between the wheels all the time.

Several speed ratios are available for the drive axle. These ratios depend upon the motor and transmission. Also, special applications may suggest slightly different gear ratios.

#### 1.2 Drive Axle Lubrication

Additional lubrication information is covered in "Field Maintenance Manual No. 5" annexed to the end of this section. During initial stage of normal operation, tiny metal particles originating from moving parts can be found on mating surfaces. These particles are carried by the lubricant through the assembly and act as lapping compound which accelerates wear of all parts. To ensure maximum life of the differential and prevent premature failure, the original "factory fill" lubricant should be drained. Change break-in oil after 3,000 miles (4 800 km) of initial operation (drain the unit while it is still warm from operation), in accordance with the lubrication and servicing schedule.

Change differential oil and clean the breathers, the magnetic fill and drain plug, every 100,000 miles (160 000 km) or once every two years, whichever comes first. Use Multigrade gear oil MIL-L-2105-D. Use the 75W90 gear oil for northern climates and the 80W140 for southern climates. In extreme conditions, or for better performance, fill with synthetic gear oil.

Check oil level and if necessary add oil every 6,250 miles (10 000 km) or twice a year, whichever comes first (Fig. 1).

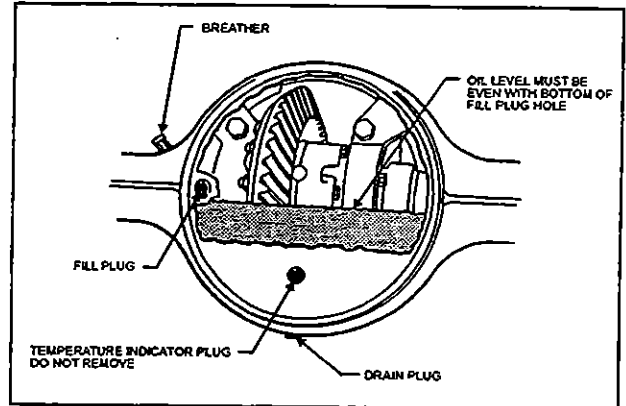

Figure 1: Differential Axle Housing Bowl

11007

#### 1.3 Maintenance

Proper vehicle operation begins with preventive maintenance, such as good differential use. The most common types of drive axle carrier failures are spinout, shock, fatigue, overheating and lubrication. Avoid neglecting these points as it would be the first step to improper maintenance, expensive repairs, and excessive downtime.

Inspect the pinion oil seal, axle shaft flange and carrier housing gaskets for evidence of lubricant leakage. Tighten the bolts and nuts, or replace the gaskets and seals to correct leaks. Maintenance of the axle mountings consists primarily in a regular and systematic inspection of the air suspension units and radius rods, as directed in Section 16, "Suspension".

##### 1.3.1 Checking and Adjusting the Oil Level

1. Make sure the vehicle is parked on a level surface.

**Caution:** Check the oil level when the axle is at room temperature. When hot, the oil temperature may be 190°F (88°C) or more and can cause burns. Also, a correct reading is not obtained when the axle is warm or hot.

2. Make sure the axle is "cold" or at room temperature.
3. Clean the area around the fill plug. Remove the fill plug from the differential axle housing bowl.
4. The oil level must be even with the bottom of the hole of the fill plug.
  - a. If oil flows from the hole when the plug is loosened, the oil level is high. Drain the oil to the correct level.
  - b. If the oil level is below the bottom of the hole of the fill plug, add the specified oil.
5. Install and tighten the fill plug to 35-50 lbf·ft (48-67 N·m).

### 1.3.2 Draining and Replacing the Oil

1. Make sure the vehicle is parked on a level surface. Put a large container under the axle.

**Note:** *Drain the oil when the axle is warm.*

2. Remove the drain plug from the bottom of the axle. Drain and discard the oil.
3. Install and tighten the drain plug to 35-50 lbf·ft (48-67 N·m).
4. Clean the area around the fill plug. Remove the fill plug from the differential housing bowl.
5. Add the specified oil until the oil level is even with the bottom of the hole of the fill plug. Allow the oil to flow through the axle and check the oil level again (lube capacity 41 pints [13,3 liters]).
6. Install and tighten the fill plug to 35-50 lbf·ft (48-67 N·m).

### 1.3.3 Differential Oil Sensor (if applicable)

An oil temperature sensor is located in the housing bowl and the gauge is located on the R.H. dashboard. The normal operating temperature is below 250°F (120°C).

**Caution:** *The differential overheats when the differential oil temperature rises above 250°F (120°C).*

## 1.4 Removal and Replacement

The following procedure deals with the removal of the drive axle assembly and its attachments as a unit. The method used to support the axle during removal and disassembly depends upon local conditions and available equipment.

### 1.4.1 Removal

1. Raise vehicle by its jacking points on the body (see Section 18, "Body" under heading "Vehicle Jacking Points"). Place jack stands under frame. Remove drive axle wheels (if required, refer to Section 13, "Wheels, Hubs and Tires").
2. Exhaust compressed air from the air supply system by opening the drain cock of each air reservoir.
3. Disconnect the propeller shaft as directed in Section 9, "Propeller Shaft", of this manual.
4. On both sides of the vehicle, unscrew fasteners retaining front wheelhouse plastic guards, and remove them from vehicle.
5. Disconnect both height control valve links from air spring mounting plate brackets.

## Section 11: REAR AXLES

---

6. Remove cable ties securing the ABS cables (if vehicle is so equipped) to service brake chamber hoses. Disconnect the ABS cable connectors located at the opposite extremity of the sensor ends.

**Note:** When you remove cable ties to ease operation, remember to replace them afterwards.

7. Disconnect the brake chamber hoses. Position the hoses so they will not be damaged when removing the axle.
8. Install jacks under the axle jacking points to support the axle weight.
9. Remove the four shock absorbers as outlined in Section 16, "Suspension" under heading "Shock Absorber Removal".
10. Remove the sway bar.
11. Remove the lower and upper longitudinal radius rod supports from vehicle subframe as outlined in Section 16, "Suspension", under heading "Radius Rod Removal".

**Note:** The upper mounting bolt of each lower radius rod support is accessible from the last baggage compartment.

12. Remove the transversal radius rod support from the vehicle subframe.
13. Remove the two retaining nuts from each of the four air bellows lower mounting supports.
14. Use the jacks to lower axle. Carefully pull away the jacks axle assembly from under the vehicle.

### 1.4.2 Replacement

Reverse removal procedure to reinstall drive axle.

**Note:** Refer to Section 16, "Suspension" for suspension components proper torques tightening.

### 1.5 Disassembly and Reassembly

Disassembly and reassembly procedures are explained under applicable headings in "Rockwell Field Maintenance Manual, No. 5", annexed to this section.

### 1.6 Gear Set Identification

Gear set identification is explained under applicable heading in "Rockwell Field Maintenance Manual No. 5", annexed to this section.

### 1.7 Adjustments

Adjustments are explained under applicable headings in Rockwell Field Maintenance No. 5, annexed to this section.

### 1.8 Fastener Torque Chart

A differential fastener torque chart is provided in Rockwell Field Maintenance No. 5, annexed to this section.

### 1.9 Tire Matching

Drive axle tire matching is explained under the applicable heading in Section 13, "Wheels, Hubs and Tires", of this manual.

## 1.10 Drive Axle Alignment

### 1.10.1 Description

The drive axle alignment consists in aligning the axle according to the frame. The axle must be perpendicular to the frame. The alignment is achieved with the use of shims inserted between the lower longitudinal radius rod supports and the frame.

Drive axle alignment is factory set and is not subject to any change, except if the vehicle has been damaged by an accident or if there are requirements for replacement.

**Caution:** *If this setting is altered significantly, the vehicle will produce offset tracking (dog tracking).*

If the axle has been removed for repair or servicing and if all the parts are reinstalled exactly in the same place, the axle alignment is not necessary. However, if the suspension supports have been replaced or altered, proceed with the following instructions to verify or adjust the drive axle alignment.

### 1.10.2 Procedure

1. Park vehicle on level floor, then chock front vehicle wheels.
2. Using two jacking points (which are at least 30 inches [76 cm] apart) on drive axle, raise the vehicle sufficiently so that wheels can turn freely at about ½ inch from ground. Secure in this position with safety stands, and release parking brake.
3. Using an optical toe and tracking system installed on each side of the drive axle, fix and position the projector in the center of the wheel. Measure the distance on each side of projector mounting rods. Distance should be equal on both sides. If not, adjust the projector.
4. Install a target board on each side of the vehicle, at the level of the last baggage compartment front wall (see installation in Fig. 2).
5. Connect the projectors and set to zero. Rotate the wheel and set projectors to zero at four opposite positions. It is important to have a zero marking when rotating the wheel in order to eliminate wheel run-out.
6. Aim projector on the target board. Measure distance between target center line (provided by the projector) and the frame post located immediately beside the target board.  
  
Record measurement, then repeat procedure on the other side (refer to Fig. 2). Dimensions obtained are identified RR on rear right-hand side and RL on rear left-hand side.
7. Move the target boards to the front of vehicle, i.e. at 13 feet towards the first target location (Fig. 2) for installation.

## Section 11: REAR AXLES

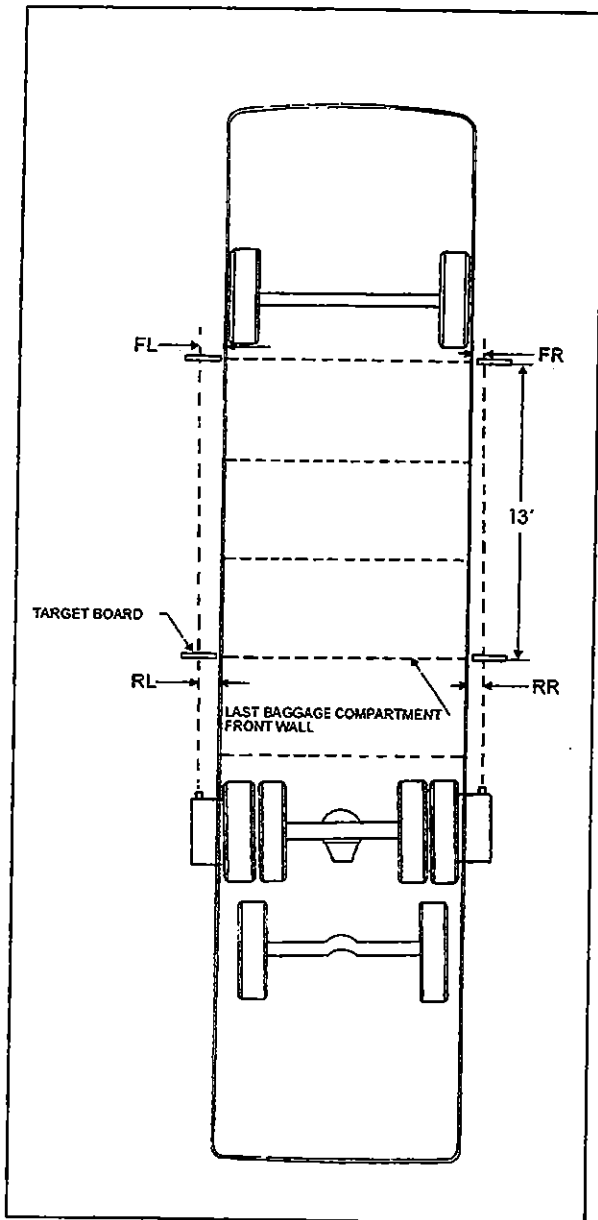

Figure 2: Drive Axle Alignment

11008

8. Aim the projector on the target board, then measure the distance between target centerline (provided by the projector) and the frame post located immediately beside the target board. Record measurement, then repeat on the other side. Dimensions obtained are identified FR on front right-hand side and FL on front left-hand side.

9. Subtract measurement taken at rear of the vehicle from measurement taken at front of the vehicle on the same side. Record results. Repeat previous operation on other side of vehicle. Record results.

**FR - RR = RESULT "A"**  
**FL - RL = RESULT "B"**

10. The results on either side must be less than or equal to 5/8 inch (16 mm) for H3-41 and 9/16 inch (14 mm) for H3-45 vehicles. These results are obtained with a distance of 13 feet between the two target board locations. If one or both results exceed the value specified for the vehicle, corrective action should be taken with respect to axle position.
11. Correct axle position by inserting a shim between the lower longitudinal radius rod support and the frame, on right or left side of vehicle, according to the previous results.

**Note:** Refer to Section 16, "Suspension", for proper torque tightening of the longitudinal radius rod support nuts.

12. Repeat steps 6 to 10 to ensure that axle is truly perpendicular to the frame.

## 2. TAG AXLE

### 2.1 Description

The tag axle is located behind the drive axle. It carries a single wheel and tire on each side. The standard system allows unloading of the tag axle air springs without raising the axle, while the optional system enables unloading and raising of the tag axle (refer to Operator's Manual for details about control location). Both these systems have been designed for the following purposes:

1. Shortening of wheelbase, thus allowing tighter turning in tight maneuvering areas such in a parking lot or when making a sharp turn.



2. Transferring extra weight and additional traction to the drive wheels on slippery surfaces.

**Caution:** *Never exceed 30 mph (50 km/h) with tag axle up or unloaded for normal driving.*

The tag axle service brakes operate only when the axle is in normal driving (loaded) position.

## 2.2 Lubrication

Repack the tag axle wheel bearing with multipurpose grease every 50,000 miles (80 000 km) or once a year, whichever comes first. Use a good quality lithium-base grease: NLGI No. 2 (suitable for most temperatures) or NLGI No. 1, (suitable for extremely low temperatures).

## 2.3 Removal and Replacement

The following procedure deals with the removal of the tag axle assembly along with the suspension components. The method used to support the axle and suspension components during removal and disassembly depends upon local conditions and available equipment.

### 2.3.1 Removal

1. Raise vehicle by its jacking points on the body (see Section 18, "Body" under heading "Vehicle Jacking Points"). Place jack under frame. Remove drive axle wheels (if required, refer to Section 13, "Wheels, Hubs and Tires").
2. Exhaust compressed air from the air supply system by opening the drain cock of each air reservoir.
3. Install jacks under tag axle jacking points to support the axle weight.
4. Only for vehicle equipped with the retractable tag axle. Disconnect tag axle lifting chain collars from lower longitudinal radius rods

5. Remove the propeller shaft as directed in Section 9, "Propeller Shaft", of this manual.
6. Disconnect the tag axle brake chamber hoses. Position the hoses so they will not be damaged when removing axle.
7. Disconnect hose from the air spring upper mounting plate.
8. Remove the two shock absorbers as outlined in Section 16, "Suspension", under "Shock Absorber Removal".
9. Disconnect the lower longitudinal radius rods as outlined in Section 16, "Suspension", under "Radius Rod Removal".
10. Disconnect the transversal radius rod.
11. Disconnect the upper longitudinal radius rod.
12. Remove the retaining nuts of the air bellows from each of the two upper mounting plates.
13. Use the jacks to move the axle forward to clear the axle of the transmission. Lower the axle.

**Caution:** *On vehicles equipped with an automatic transmission (with or without the output retarder), move tag assembly very carefully. Pay special attention to the U-shaped section, as the transmission end components may be easily damaged through a false maneuver.*

### 2.3.2 Replacement

Reverse removal procedure to reinstall tag axle.

**Note:** *Refer to Section 16, "Suspension", for proper torque tightening of suspension components.*

## 2.4 Tag Axle Alignment

### 2.4.1 Description

The tag axle alignment consists in aligning the tag axle parallel to the drive axle position. Before aligning the tag axle, proceed with the drive axle alignment (see previous paragraph). Tag axle alignment is achieved with the use of shims inserted between the lower longitudinal radius rod supports and axle. Tag axle alignment is factory set and is not subject to any change, except if vehicle has been damaged by an accident or if there are requirements for part replacement.

**Caution:** *If this setting is altered significantly, it will cause excessive wear.*

If axle has been removed for repair or servicing and if all parts are reinstalled exactly in the same place, axle alignment is not necessary. However, if the suspension supports have been replaced or have changed position, proceed with the following instructions to verify or adjust the tag axle alignment.

### 2.4.2 Procedure

1. Park the vehicle on level floor. Unload tag axle (or lift, if so equipped) using the appropriate control located on the right lateral console (refer to the H3 Operator's Manual for details). Chock front vehicle wheels.
2. Using two jacking points (which are at least 30 inches [76 cm] apart) on drive axle, raise vehicle sufficiently so that wheels are raised about ½ inch from ground and secure in this position with safety stands.
3. Using jacking points on tag axle, raise axle sufficiently (no more than ½ inch from the ground) to turn tag axle wheels freely.

4. Using an optical toe & tracking system installed on each side of the drive axle, fix and position the projector in center of wheel. Measure the distance on each side of the projector mounting rods. The distance should be equal on both sides. If not, adjust the projector.
5. Install a mirror on each side of vehicle, at level of the last baggage compartment front wall (Fig. 3) for installation.
6. Connect the projector and set it to zero. It is important to have a zero marking when rotating the wheel in order to eliminate wheel run-out.
7. Aim the projector at the mirror, and adjust the mirror to reflect the beam light reflection exactly on the zero position of the projector centering plate.
8. Move the optical toe and tracking system installed on each side of the drive axle on the tag axle.
9. Aim the projector on the mirror as indicated in step 7.
10. The reflected beam of light on the centering plate of the projector should be within  $0 \pm 3/64^\circ$ .
11. If necessary, correct tag axle position by inserting a shim between the lower longitudinal rod support and the tag axle, on the right or the left side of vehicle according to results obtained.

**Note:** *Refer to Section 16, "Suspension", for proper torque tightening of the longitudinal radius rod support nuts.*

12. Repeat steps 4 to 10 to ensure that axle is truly parallel to the drive axle.

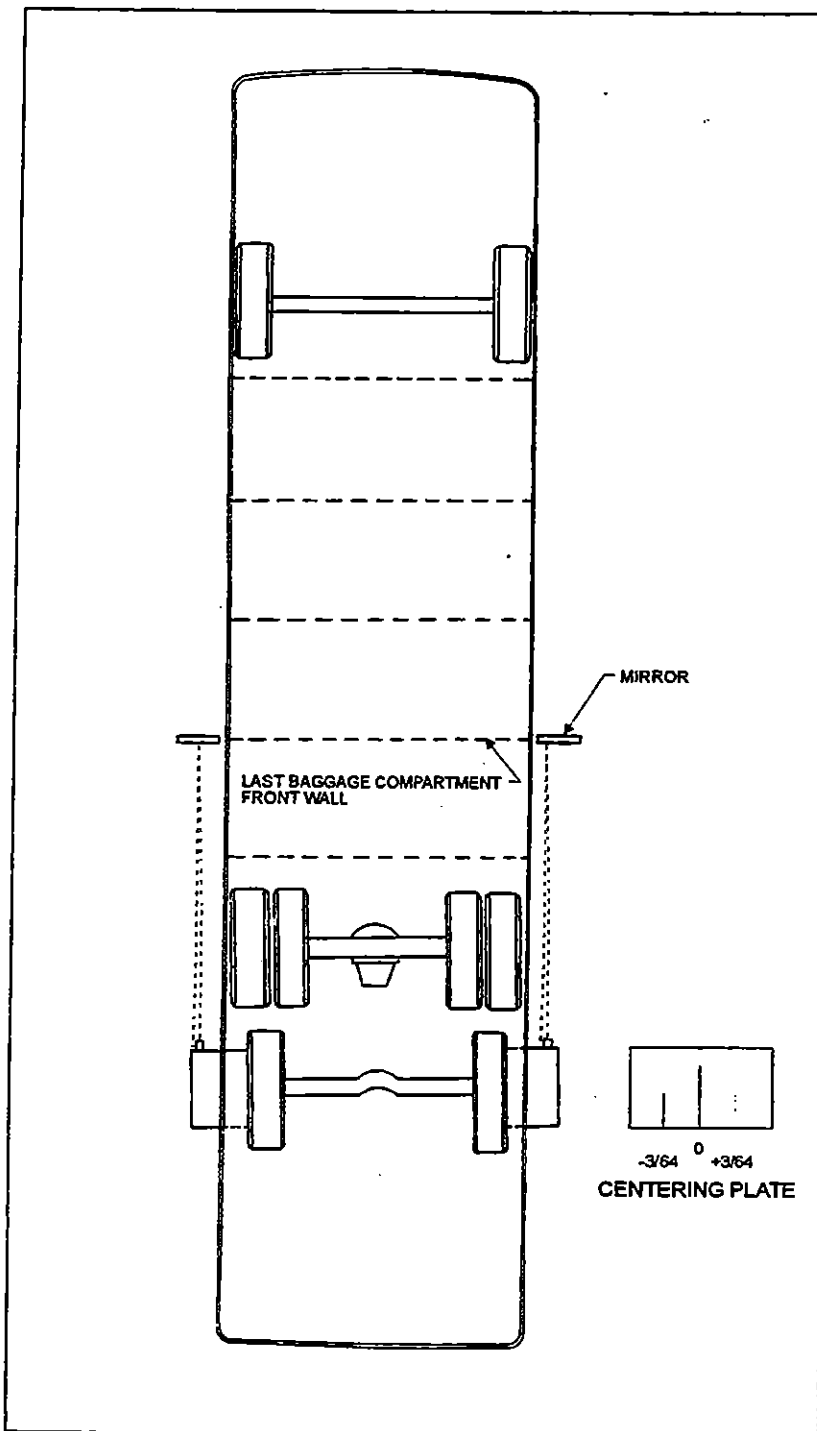

Figure 3: Tag Axle Alignment

11009

**Section 11: REAR AXLES**

**3. SPECIFICATIONS**

**Drive Axle**

Make ..... Rockwell International  
 Drive track ..... 76.7 inches (1 949 mm)  
 Gear type ..... Hypoid  
 Axle type ..... Full floating  
 Lube capacity ..... 41 pints (19,3 liters)

**Drive axle ratio**

w/11.1L - PS130-6B and w/12.7L - PS145-7A

3.21:1 Standard

3.07:1 Optional

World Transmission

4.88:1 Standard

4.56:1 Optional

Drive Axle Alignment Specifications		
Off Tracking: Prévost's procedure	Spec.	Inst.
H3-41 (Both sides) H3-45 (Both sides)	5/8 inch max. on 13 feet 9/16 inch max. on 13 feet	Projector

**Tag Axle**

Make ..... Prévost  
 Type ..... GKN TS5 hub unit  
 Rear track ..... 83.6" (2 124 mm)

Tag Axle Alignment Specifications				
Toe: Prévost's procedure	Minimal	Nominal	Maximal	Inst.
H3-41 and H3-45 (Both sides)	-3/64	0	+3/64	Mirror

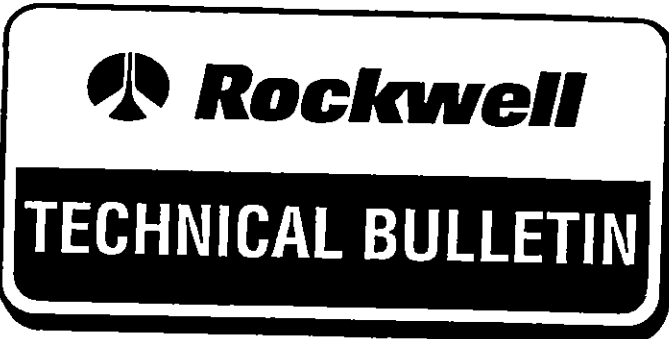

# Removing and Installing The Rockwell In-Axle Speed Sensors (For Anti-Lock Brake Systems, ABS)

When a vehicle is equipped with an anti-lock brake system that has Rockwell in-axle mounted speed sensors, there are two sensor assemblies in the differential carrier. The speed sensors mount into each adjusting ring of the differential bearings. **Figure 1.**

Service both speed sensors by using the following instructions and the procedures from Rockwell Maintenance Manuals No. 5 or 5L that are indicated in the steps.

Use Maintenance Manual No. 5 if the speed sensors are mounted in a single drive axle or the rear axle of a tandem. Use Maintenance Manual No. 5L if the speed sensors are mounted in the forward axle of a tandem.

**NOTE:**

*Illustrations used in this publication are of an RS-145 Series single drive axle. The parts and location of the connectors of 160 and 180 Series single and tandem axles may vary from those shown.*

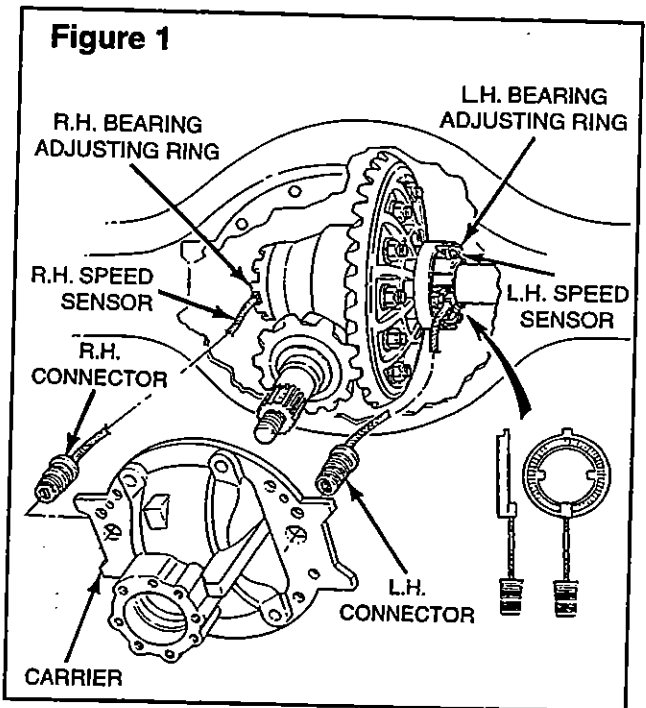

One speed sensor assembly and all related parts are shown in **Figure 2.** Use Figures 1 and 2 as a reference when using these instructions.

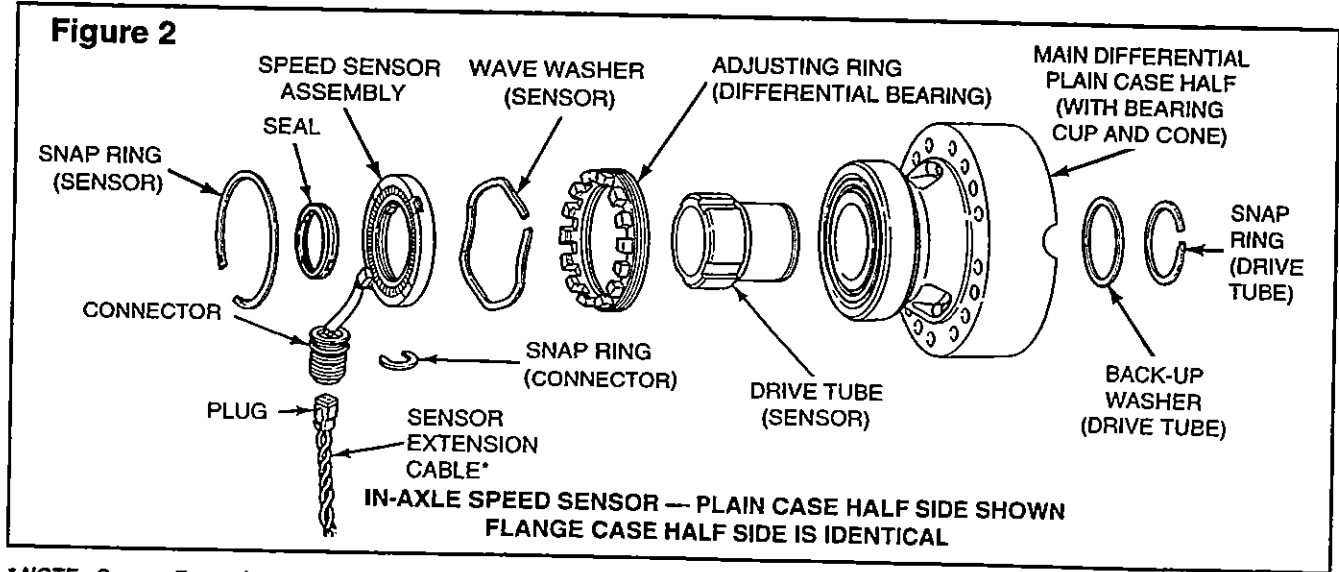

\* NOTE: Sensor Extension Cable — it is recommended that the two wires be twisted together at greater than 20 turns per meter.

## Remove the Speed Sensor

### **WARNING**

*The Rockwell Speed Sensor is part of an electrical system. When you work on the speed sensor, take the same precautions as you must take with any electrical system to avoid serious personal injury. As with any electrical system, there is a danger of electrical shock or sparks which can ignite flammable substances. Always disconnect the battery ground cable before working on the speed sensor or electrical system.*

*Wear safe eye protection to help prevent serious personal injury when servicing the vehicle.*

*Do not work under a vehicle that is supported only by jacks. Jacks can slip or fall over and cause serious personal injury. Support the vehicle with jack stands.*

1. Follow steps 1 and 2 of Remove Differential Carrier From Axle Housing in Section 2, Disassembly, on page 4 of Maintenance Manual No. 5.
2. Shut off the vehicle ignition.
3. Disconnect the ground cable from the battery.

### **CAUTION**

*Do not disconnect the sensor plug from the connector by pulling the sensor extension cable. Damage to the plug will occur and cause an open circuit. Always disconnect the sensor by pulling the plug housing.*

4. Disconnect the left-hand and right-hand sensor plugs from the connectors. See **Figures 1 and 3** for the location of the parts.

In one action, hold the plug, press the lock tab on the top of the plug housing and pull the plug from the connector. **Figure 3**.

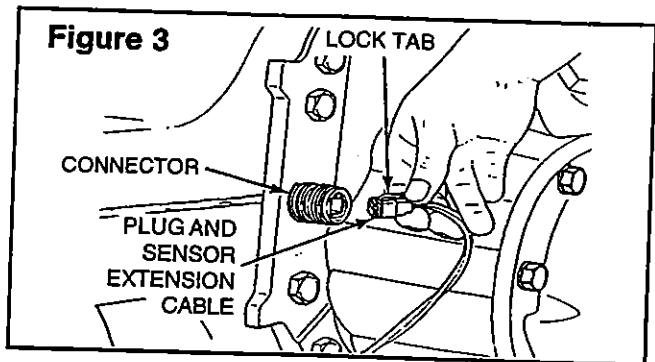

### **NOTE:**

*Before continuing on, perform the following Sensor Continuity Test.*

## Sensor Continuity and Short Tests

- A. **Sensor Continuity Test** — Sensor resistance should be 1080 to 1320 ohm ( $\Omega$ ) at 70°F; however, it may vary between 900 to 1500 ohm ( $\Omega$ ) depending upon large temperature extremes. **Figure 4**.

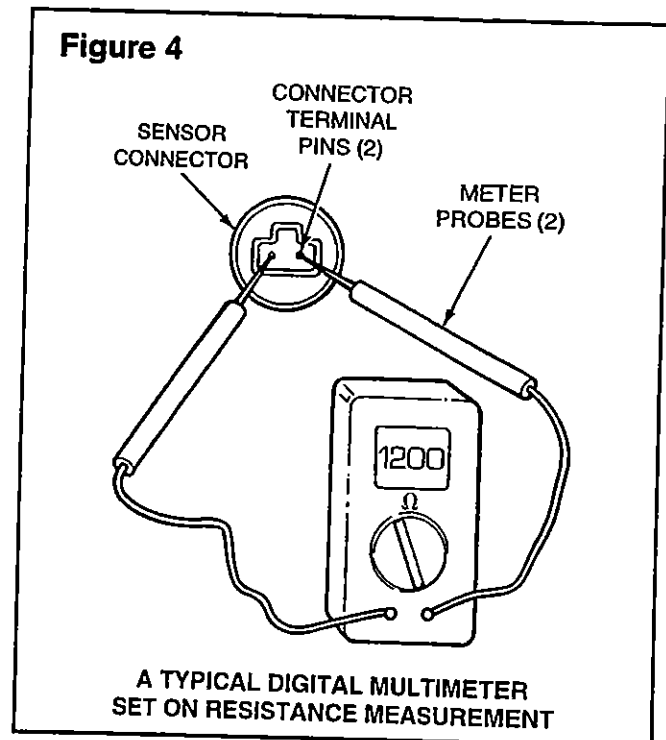



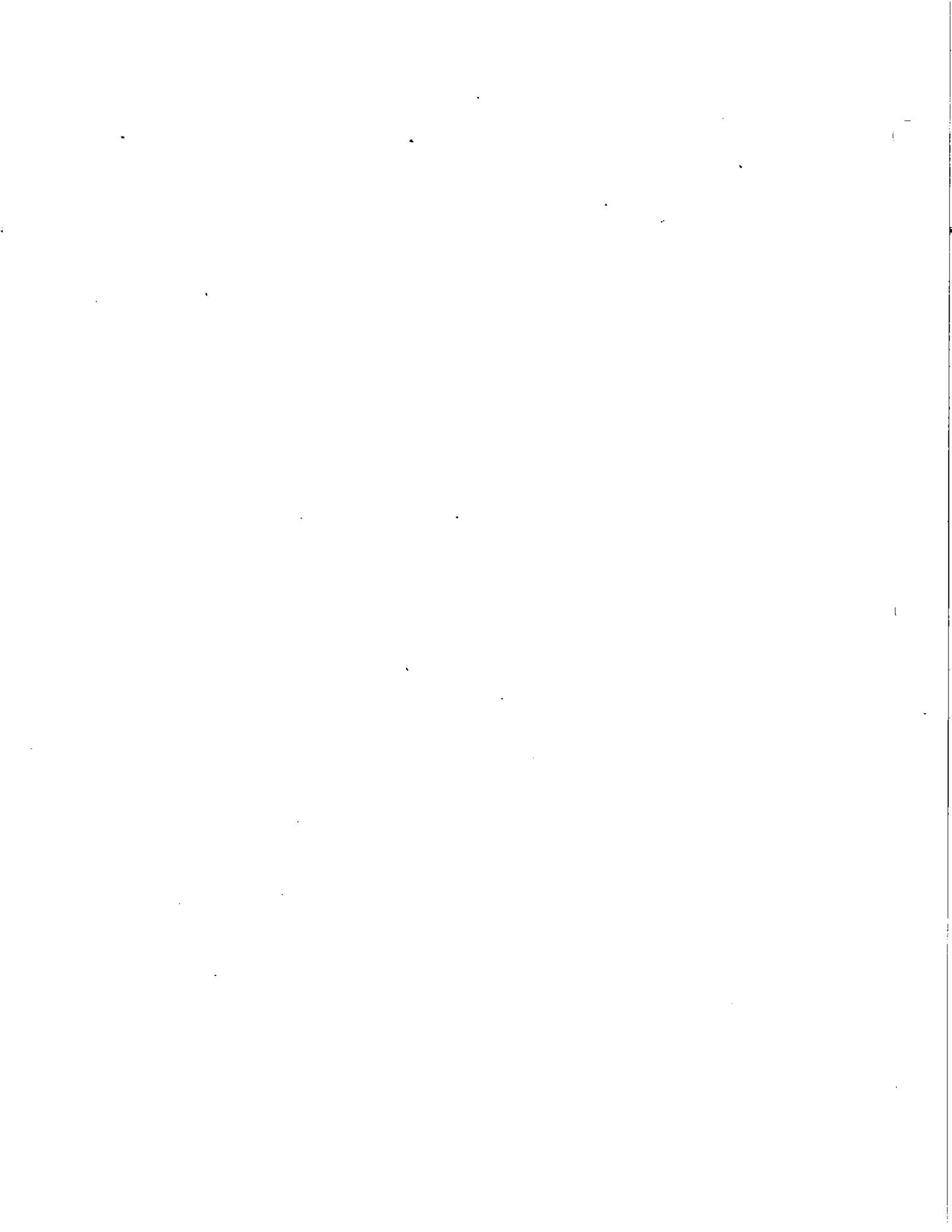



- B. **Sensor Short Test** — Test for short between sensor connector and carrier/ axle housing before removing and after installing the carrier into housing. **Figure 5.**

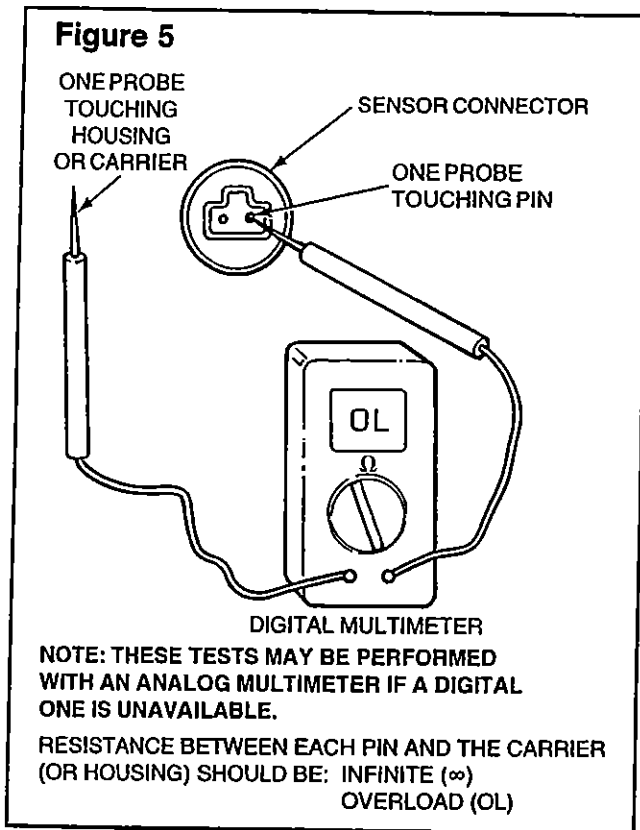

5. If you are using Maintenance Manual No. 5, follow steps 3-15 of Remove Differential Carrier From Axle Housing in Section 2, Disassembly, starting on page 4.

If you are using Maintenance Manual No. 5L, follow steps 1-6, 8-21 and 23 of Removing the Differential Carrier From the Axle Housing in Section 3, Disassembly, starting on page 7.

6. Remove the snap ring that holds the speed sensor in the adjusting ring of the differential bearing. Use snap ring pliers. **Figure 6.**

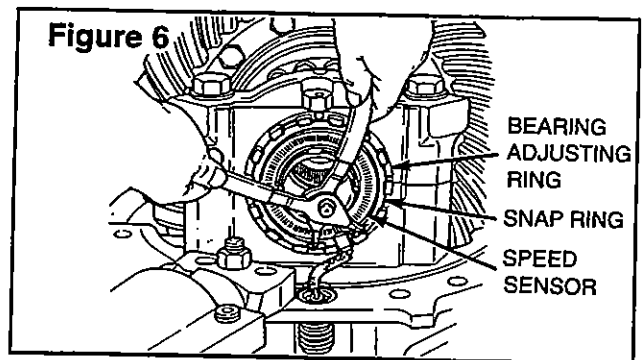

**CAUTION**

*When you pry out the speed sensor from the bearing adjusting ring always position the screwdrivers under the metal tabs. Do not pry out the sensor from the plastic wire outlet area of the coil. Damage to the coil will occur.*

7. Pry the speed sensor loose but do not completely remove it from the bearing adjusting ring. Use two screwdrivers to pry the sensor at the two opposite tabs. **Figure 7.**

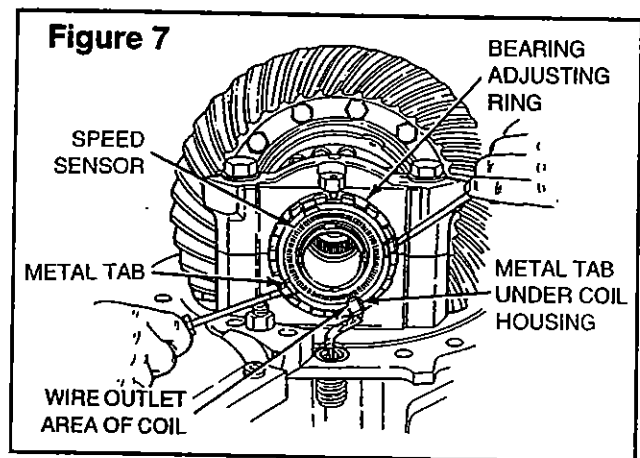

8. Both sensor connectors are mounted through bores in the flange of the carrier. Using two screwdrivers, pry the snap ring out of the groove in both the left-hand and right-hand sensor connectors. **Figure 8.**

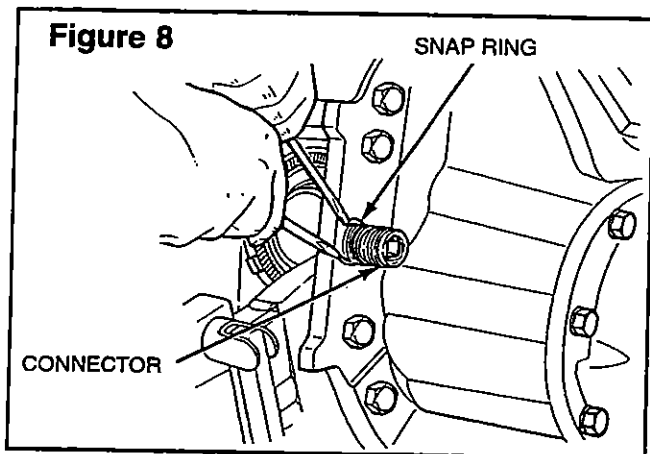

9. Using your thumbs, push the connector through the hole in the flange of the carrier. Push from the outside surface of the flange toward the inside surface. **Figure 9.**

If it is difficult to remove the connector in this manner, position and hold a block of wood against the connector. Use a mallet to tap against the wood and drive the connector through the carrier flange.

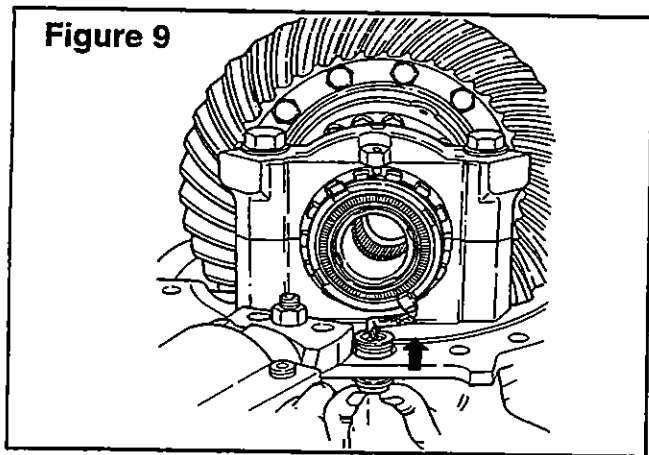

**CAUTION**

When you remove the speed sensor assembly from the bearing adjusting ring, do not drop the assembly, damage to the components can occur.

10. Completely remove the speed sensor assembly by pulling it out from the bearing adjusting ring. **Figure 10.**

Complete removal of the speed sensor can also be done by using two screwdrivers as indicated in step 7.

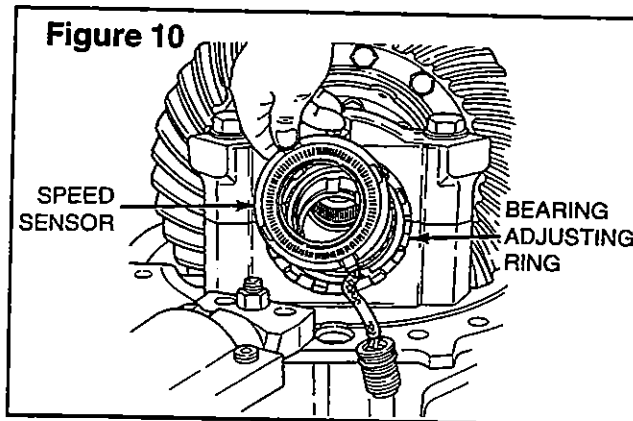

11. Remove the wave washer from inside the bore of the bearing adjusting ring. **Figure 11.**

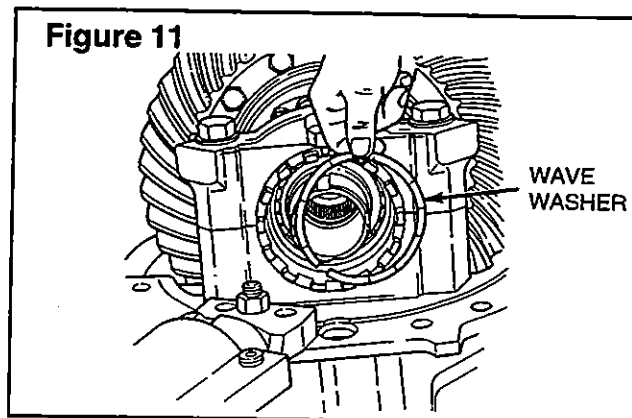

**NOTE:**

Removal of the drive tubes from the differential case halves is not a requirement to remove the speed sensors. Remove the drive tubes from the case halves only if required due to damaged parts. **Figure 12.** Continue with step 12. Otherwise continue with "Prepare Parts for Assembling," page 5.

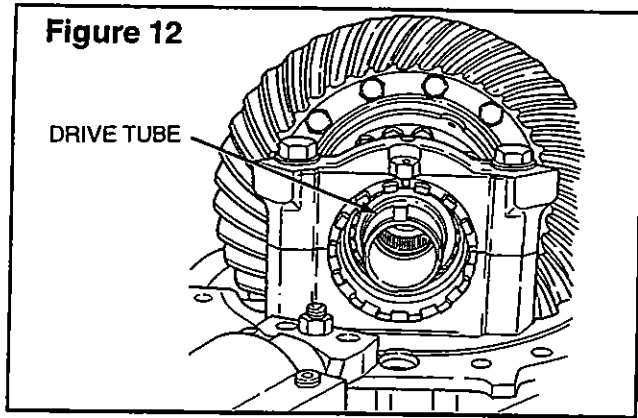

12. If you are using Maintenance Manual No. 5, continue with the following steps in Section 2, Disassembly:

- Page 5, all steps of Remove The Differential and Ring Gear From The Carrier.
- Page 8, steps 1-4 of Disassemble The Differential And Ring Gear Assembly.

If you are using Maintenance Manual No. 5L, continue with the following steps in Section 3, Disassembly:

- Page 21, steps 1-7 of Removing The Main Differential Case And Ring Gear Assembly.
- Page 22, steps 1-3 of Disassembling The Main Differential Case And Ring Gear.

13. Using a screwdriver, remove the snap ring that holds the drive tube in position inside the differential case half. **Figure 13.**

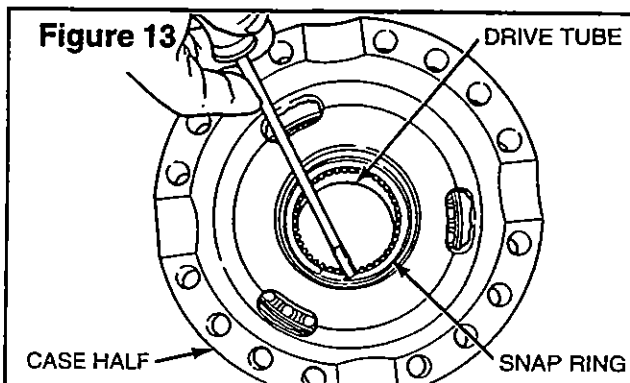

14. Lift out the back-up washer that is behind the snap ring, inside the differential case half. **Figure 14.**

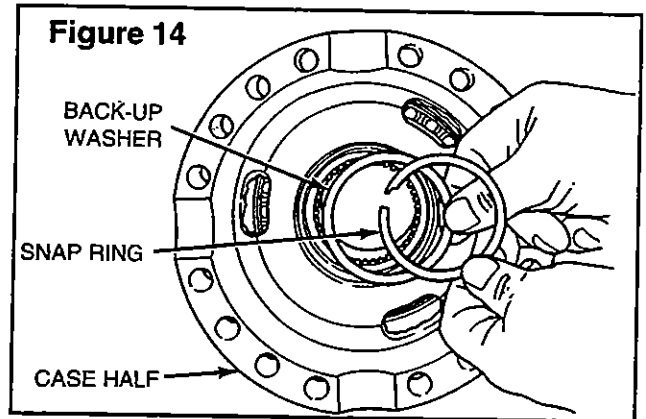

15. Pull the drive tube out from the bearing side of the differential case half. **Figure 15.**

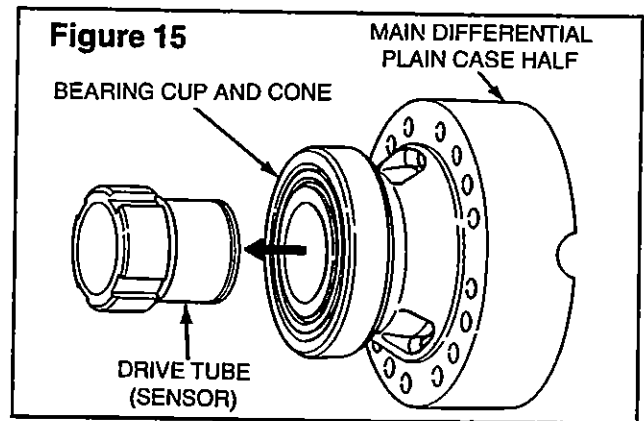

## Prepare Parts For Assembling

### **CAUTION**

*Do not clean the speed sensor assembly by using cleaning solvents. Damage to components can occur. Clean the speed sensor assembly only with a clean dry rag or paper towel.*

1. If you are using Maintenance Manual No. 5, continue with the following:

- Section 3, Prepare Parts for Assembly, starting on page 15, all necessary steps.
- Section 4, General Procedures, starting on page 20, all necessary steps.

If you are using Maintenance Manual No. 5L, continue with the following:

- Section 4, Prepare the Parts for Assembly, starting on page 25, all necessary steps.
- Section 5, General Information, starting on page 31, all necessary steps.

## Install the Speed Sensors

If the drive tube was not removed, start with the **Note** before **Figure 18** and step 4 on page 7.

1. Install the drive tube into the differential case half from the bearing side. **Figure 16**.

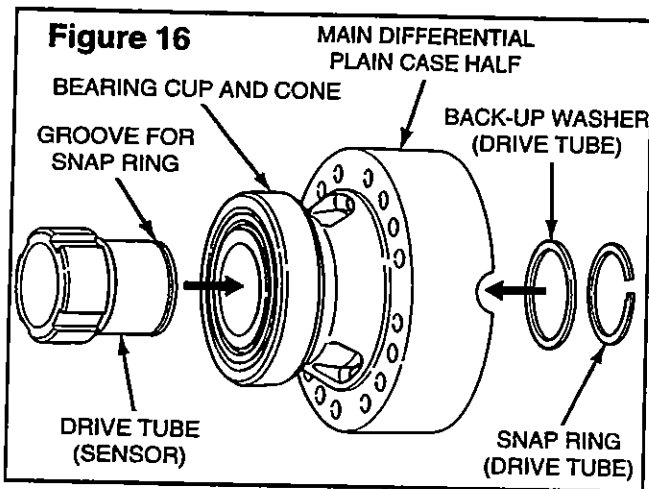

2. While holding the drive tube in position, place the back-up washer over the drive tube and against the inside of the differential case half. Install the snap ring into the groove in the drive tube using a screwdriver if necessary. **Figures 16 and 17**.

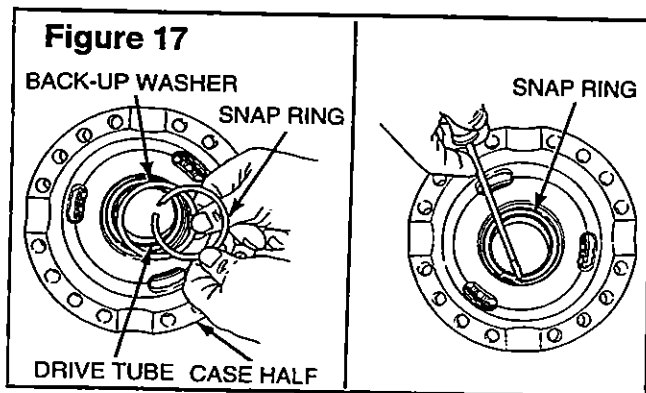

3. If you are using Maintenance Manual No. 5, continue with the following steps in Section 5, Assembly:

- Page 39, steps 9-16 of Assemble the Main Differential and Ring Gear Assembly.

Continue with all steps of the following procedures in Section 5, Assembly:

- Page 41, Rotating Resistance Check of Differential Gears.
- Page 42, Install the Differential and Ring Gear Assembly.
- Page 43, Adjust Preload of Differential Bearings.
- Page 45, Check Runout of Ring Gear.
- Page 45, Adjust Backlash of the Ring Gear.
- Page 47, Check Tooth Contact Patterns of the Gear Set.
- Page 50, Install and Adjust the Thrust Screw.

If you are using Maintenance Manual No. 5L, continue with the following steps in Section 6, Assembly:

- Page 45, steps 5-13 of Assembling the Main Differential Case and the Ring Gear.

Continue with all steps of the following procedures in Section 6, Assembly:

- Page 46, Checking the Rotating Resistance of the Side Gears in the Main Differential Case.
- Page 47, Installing the Main Differential Case and Ring Gear Assembly into the Carrier.
- Page 49, Adjusting the Preload on the Differential Bearings.
- Page 51, Checking the Runout of the Ring Gear.
- Page 52, Adjusting the Backlash of the Ring Gear.
- Page 53, Checking the Tooth Contact Patterns of the Gear Set.

**NOTE:**

*Before you start installing the speed sensor assembly and components into the bearing adjusting ring, check the position of the roll pin that locks the adjusting ring in place. Correct installation of the speed sensor cannot be done if the roll pin extends beyond the snap ring groove in the lugs of the adjusting ring. Adjust the position of the roll pin, if necessary, by using a drift and hammer. Figure 18.*

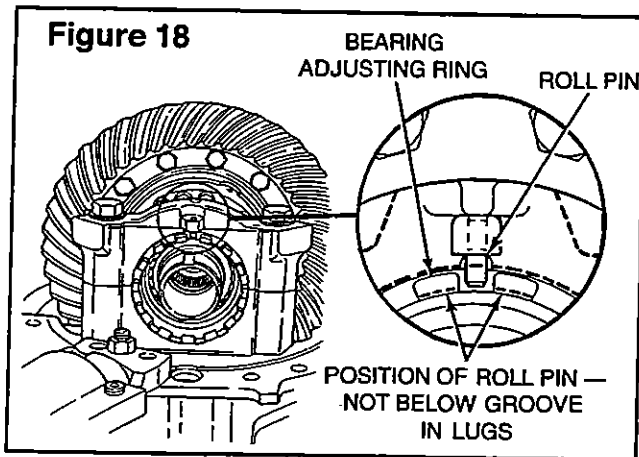

4. Check the outside of the speed sensor connector, there must be an O-ring positioned in the first groove. Install an O-ring if necessary. Figure 19.

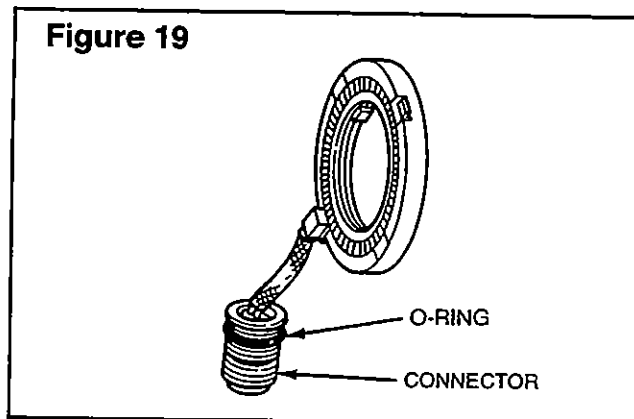

**CAUTION**

*If an old sensor assembly is being installed, a visual inspection of the cables should be performed. If there is evidence of broken wire insulation the sensor assembly may not function correctly. The old sensor assembly should be replaced.*

5. Using your thumbs, push the connector of the speed sensor through the large hole in the carrier flange. Push from the inside surface of the flange toward the outside surface.
6. Using your thumb, apply and hold pressure against the back of the connector. While you hold the pressure, install the snap ring into the first full groove that appears past the outside surface of the carrier flange. Needle nose pliers are shown to install the snap ring. Figure 20. Lay the sensor on the inside face of the carrier flange and continue with step 7.

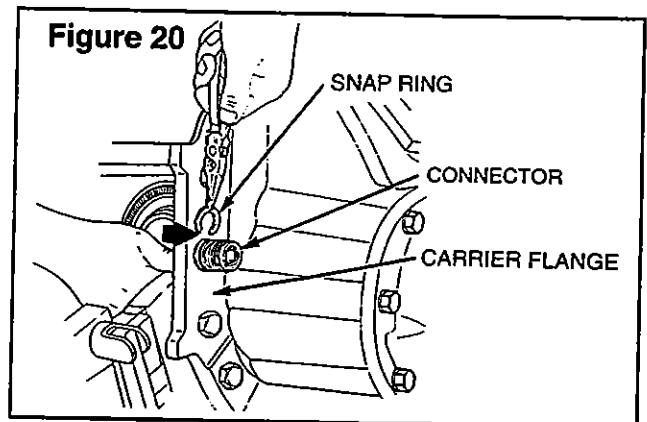

7. Install the wave washer inside the bore of the bearing adjusting ring. Figure 21.

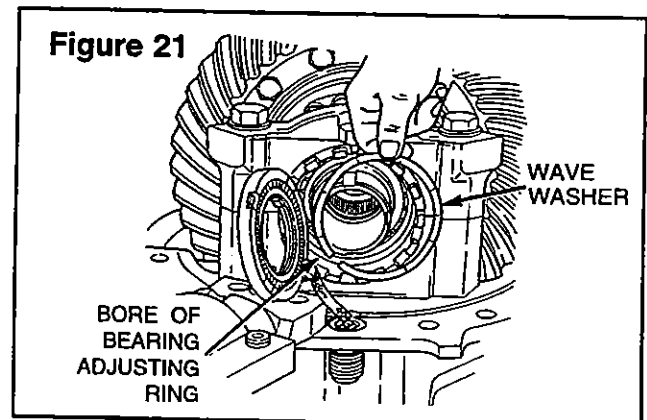

8. Apply the same lubricant that is used in the axle to the outer surface of the drive tube and on the drive seal of the speed sensor. **Figure 22.**

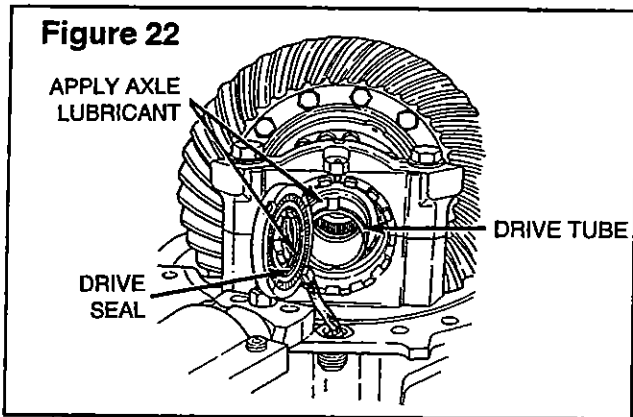

**NOTE:**

*Correct position of the speed sensors installed in the bearing adjusting rings are shown in Figures 23 and 24. The wire outlet area of the coil of each sensor must face out and be aligned with the correct slot in the adjusting ring.*

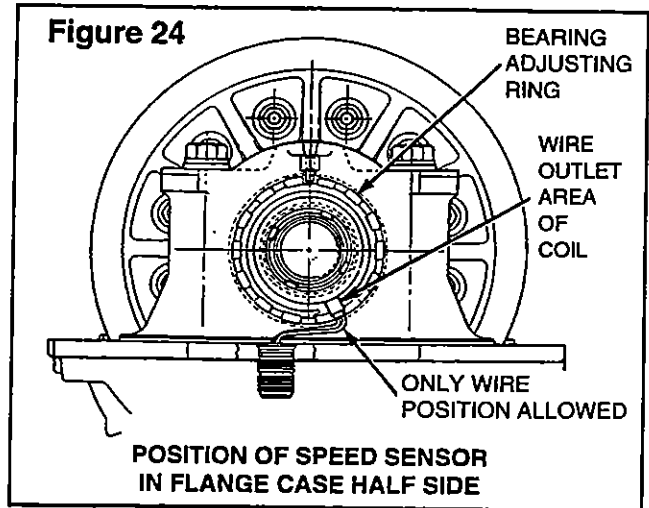
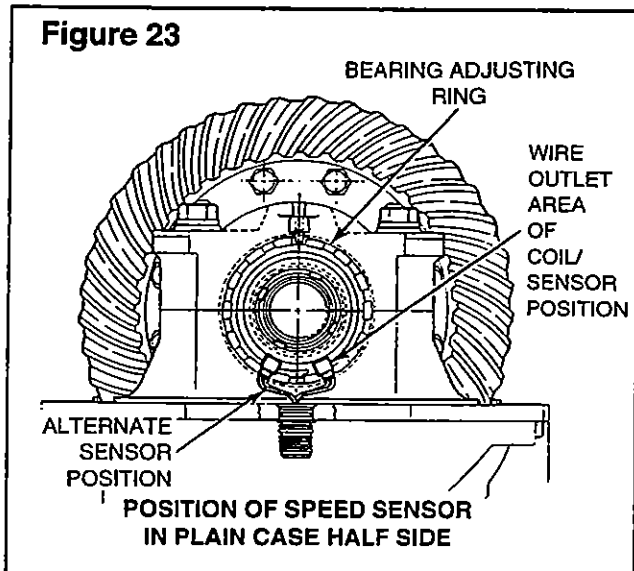

9. Place the speed sensor assembly over the bearing adjusting ring with the wires in the position shown in **Figure 23** or **24**. Turn the rotor in the sensor until the tabs align with the slots in the drive tube. **Figure 25.**

Position the sensor so the wire outlet area of the coil is centered in the slot. It must not hit the adjusting ring lug as the sensor assembly is pushed into the bore. The wire outlet area of the coil will not center itself and can be damaged during the installation.

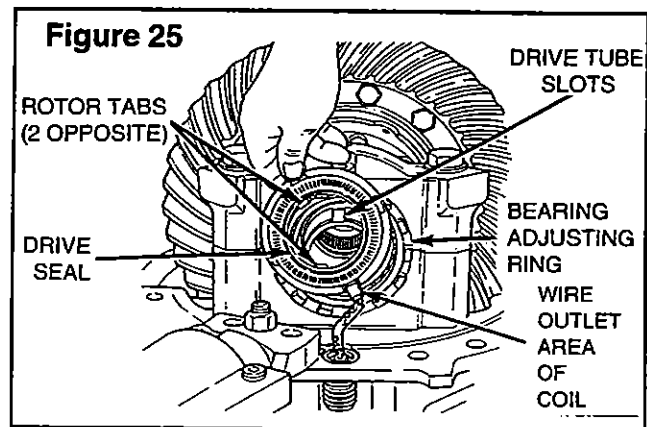

## **⚠ CAUTION**

*The speed sensor must be installed carefully and evenly into the bore of the bearing adjusting ring or damage to the sensor can occur.*

10. Press the speed sensor evenly into the bore of the bearing adjusting ring by hand while carefully sliding the drive seal over the drive tube. Watch the wire outlet area of the coil to see that it freely enters the slot and is not being distorted. Use even pressure around the sensor, near the outer diameter until the sensor is against the wave washer.

If the drive seal slips off the rotor of the sensor, remove the speed sensor from the adjusting ring. Place the drive seal in position on the rotor and repeat steps 9 and 10. **Figure 2.**

11. Press the speed sensor down into the bearing adjusting ring so that the top of the sensor is past the snap ring grooves in the lugs. Hold the sensor in this position for snap ring installation.
12. Place the snap ring over the speed sensor with the opening aligned with the wire outlet area of the coil. Start by placing one end of the snap ring in the groove close to the wire outlet area of the coil. While you apply and hold even pressure around the sensor, install the snap ring into the grooves in the lugs of the adjusting ring. Use snap ring pliers or a screwdriver, if necessary, to help install the snap ring. **Figure 26.**

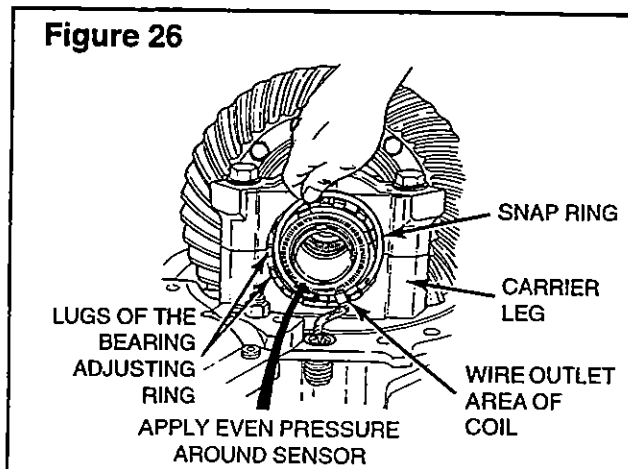

13. The sensor should position itself firmly and evenly against the snap ring. If it does not, apply hand pressure to the sensor, depressing it against the wave washer until sensor realignment occurs.

14. After the sensor is installed, make sure the outlet wires of the sensor are as close to the carrier leg as possible to be sure they will not get pinched when the carrier is installed in the axle housing.

15. If you are using Maintenance Manual No. 5, continue with the following steps:

- Section 5, Assembly, page 51, all steps of Install Differential Carrier into Axle Housing.
- Fill the axle with the specified type and amount of lubricant. See Section 7, Lubrication, page 62.
- For additional information about lubrication, see Rockwell Maintenance Manual No. 1, Lubrication.

If you are using Maintenance Manual No. 5L, continue with the following steps:

- Section 6, Assembly, page 71, all steps of Install the Differential Carrier in the Axle Housing.

16. Perform "Sensor Continuity and Short Tests" as outlined in steps A. and B. on pages 2 and 3.

## **⚠ WARNING**

*The Rockwell Speed Sensor is part of an electrical system. When you work on the speed sensor, take the same precautions as you must take with any electrical system to avoid serious personal injury. As with any electrical system, there is a danger of electrical shock or sparks which can ignite flammable substances.*

17. Connect the ground cable to the battery.

### **NOTE:**

*You must perform a complete ABS check-out per the manufacturer's recommendations prior to returning the vehicle to service.*









North American Truck Systems  
Rockwell International Corporation  
2135 West Maple Road  
Troy, MI 48064 U.S.A.  
800-535-5560

Information contained in this publication was in effect at the time the publication was approved for printing and is subject to change without notice or liability. Rockwell International reserves the right to revise the information presented or discontinue the production of parts described at any time.

© Copyright 1995  
Rockwell International  
All Rights Reserved

Printed in the U.S.A.  
Please Recycle

TP-9597  
Issued 5/95  
16579/24240

# SECTION 12: BRAKE AND AIR SYSTEM

---

## CONTENTS

1. DESCRIPTION.....	4
1.1 Air System.....	4
1.2 Brakes.....	4
1.3 Maintenance.....	4
1.3.1 Lubrication.....	4
1.3.2 Brake Adjustment.....	4
2. AIR RESERVOIRS.....	4
2.1 Location and Function.....	4
2.2 Maintenance.....	5
2.2.1 Wet (Main) Air Tank.....	5
2.2.2 Primary Air Tank.....	5
2.2.3 Secondary Air Tank.....	5
2.2.4 Accessory Air Tank.....	5
2.2.5 Kneeling Air Tank and Emergency/Parking Brake Override Air Tank (If Applicable).....	6
3. FILL VALVES.....	6
4. ACCESSORY AIR FILTER.....	6
4.1 Element Replacement.....	6
4.2 Cleaning.....	6
5. AIR GAUGES (PRIMARY AND SECONDARY).....	6
6. AIR DRYER (SYSTEM SAVER 1000).....	7
7. AIR LINES AND HOSES.....	7
7.1 Tubing and Hoses.....	7
7.1.1 Copper Tubing.....	7
7.1.2 Nylon Tubing.....	8
7.1.3 Flexible Hoses.....	8
7.2 Air Line Serviceability Test.....	8
7.2.1 Operating Test.....	8
7.2.2 Leakage Test.....	8
7.3 Maintenance.....	8
8. PRESSURE REGULATING VALVES.....	8
8.1 Description.....	8
8.2 Maintenance.....	9
8.3 Pressure Setting Procedure.....	9
9. DOOR EMERGENCY RELEASE VALVE.....	10
9.1 Removal and Installation.....	10

**Section 12: BRAKE AND AIR SYSTEM**

---

10. AIR SYSTEM COMPONENTS .....	10
10.1 Air Compressor (TU-FLO 750) .....	10
10.1.1 Removal and Installation.....	10
10.2 Governor (D-2).....	11
10.3 Push-Pull Control Valve (PP-1) .....	11
10.4 Flip-Flop Control Valve (TW-1).....	11
10.5 Horn Valve (HV-3).....	11
10.6 Dual Brake Application Valve (E-15) .....	11
10.6.1 Brake Pedal Adjustment .....	11
10.6.2 Maintenance.....	11
10.7 Stoplight Switches.....	11
10.8 Brake Relay Valves (R-12) .....	12
10.9 Quick Release Valves (QR-1) .....	12
10.10 Spring Brake Valve (SR-1) .....	13
10.11 Pressure Protection Valve (PR-2) .....	13
10.12 Low Pressure Indicators (LP-3).....	13
10.13 Shuttle-Type Double Check Valve (DC-4) .....	13
11. AIR SYSTEM TROUBLESHOOTING.....	13
12. BRAKE OPERATION.....	14
13. AIR BRAKES .....	14
13.1 Disc Brakes .....	14
13.1.1 Disc Brake Pads.....	14
13.2 Drum Brakes .....	15
13.2.1 Maintenance.....	15
14. RECOMMENDED BRAKE SERVICE PROCEDURES TO REDUCE EXPOSURE TO NON-ASBESTOS FIBER DUST.....	15
15. AIR BRAKE TROUBLESHOOTING .....	16
15.1 Pressure Build-up / Low Pressure Warning / Cutoff Point / Governor Cutout.....	17
15.1.1 High or Low Warning Cutoff Point .....	17
15.1.2 High or Low Governor Cutout Point.....	17
15.1.3 More Than 30 Seconds to Build-up Pressure from 85 to 100 psi (585 - 690 kPa) at Full Engine RPM .....	17
15.2 Air Supply Reservoir Leakage .....	17
15.2.1 Excessive Air Loss .....	18
15.3 Air Brake Leakage .....	18
15.3.1 Excessive Leakage on Brake Service Side.....	18
16. BRAKE AIR CHAMBER .....	18
16.1 Description .....	18
16.2 Maintenance.....	19
16.2.1 Every 6,250 Miles (10 000 km) Depending on Type of Operation.....	19
16.2.2 Every Two Years or After 100,000 Miles (160 000 km) Depending on Type of Operation...	19
16.2.3 Airtightness Test .....	19

16.3	Emergency/Parking Brake Manual Release .....	19
16.3.1	Drive Axle .....	19
16.3.2	Tag Axle .....	20
16.4	Removal, Installation and Disassembly.....	20
16.4.1	Removal .....	20
16.4.2	Installation .....	20
16.4.3	Disassembly .....	20
17.	ANTI-LOCK BRAKING SYSTEM (ABS).....	21
17.1	Description .....	21
17.2	Troubleshooting and Testing .....	21
18.	ABS COMPONENTS .....	21
18.1	Electronic Control Unit .....	21
18.1.1	Description .....	21
18.1.2	Maintenance.....	22
18.2	ABS Modulator Valve.....	22
18.2.1	Description .....	22
18.2.2	Maintenance.....	22
18.3	Sensors .....	22
18.3.1	Description .....	22
18.3.2	Maintenance.....	22
18.3.3	Installation .....	22
18.4	Clamping Bush.....	23
18.4.1	Description .....	23
18.4.2	Maintenance.....	23
19.	FITTING TIGHTENING TORQUES.....	23
20.	SPECIFICATIONS .....	24

## 1. DESCRIPTION

### 1.1 Air System

The basic air system consists of an air compressor, reservoirs, valves, filters and interconnecting lines and hoses. It provides a means for breaking, operating controls and accessories, and suspension (refer to Section 16, "Suspension", for complete information on suspension description and maintenance). An air system schematic diagram is annexed to this section for better understanding of the system.

### 1.2 Brakes

This vehicle uses both the service brake and emergency/parking brake. The service brake air system is divided into two independent circuits to isolate front brakes from rear brakes, thus providing safe breaking in the event that one circuit fails. Front axle brakes operate from the secondary air system, while brakes on both the drive axle and tag axle operate from the primary air system.

**Note:** *The tag axle service brake operates only when the axle is in normal ride position (loaded and down).*

Furthermore, the brake application sequence, which is increased by a pneumatic relay valve (R-12), will start with the rear axles and will be followed by the front axle, thus providing uniform braking on a slippery road. The vehicle may also be equipped with an Anti-Lock Braking System (ABS), which is detailed later in this section.

The drive and tag axles are provided with spring-applied emergency/parking brakes, which are applied automatically whenever the control valve supply pressure drops below 40 psi (275 kPa). The optional emergency/parking brake overrule system allows the driver to release spring brakes, and to move the vehicle to a safe parking place, such as in the case of a self-application of these brakes due to a drop in air pressure.

### 1.3 Maintenance

Brake and air system maintenance consist of periodic inspections. Check all parts for damage and brake adjustment (refer to subsequent headings in this section for more details). Ensure all fasteners are tight (refer to heading "Specifications" for recommended tightening torques).

#### 1.3.1 Lubrication

On drive axle, slack adjusters, camshaft bushings and anchor pins are provided with grease fittings. Slack adjusters should be serviced every 6,250 miles (10 000 km), and camshaft bushings every 100,000 miles (160 000 km) or once every two years, whichever occurs first, whereas anchor pins and shoe rollers should be serviced when necessary, and whenever disassembling brakes, using the appropriate lubricants. Refer to Section 24, "Lubrication".

**Warning:** *Care must be taken when lubricating camshaft bushings, anchor pins and shoe rollers. Too much lubrication could cause lubrication saturation of brake linings and possible safety problems.*

#### 1.3.2 Brake Adjustment

Refer to "Rockwell Maintenance Manual no.23B - Bus and Coach Brakes" annexed to this section for drive axle.

## 2. AIR RESERVOIRS

### 2.1 Location and Function

The air coming from the air dryer is first forwarded to the wet (main) tank, then to the primary (for the primary brake system), secondary (for the secondary brake system), and accessory (for the pneumatic accessories) air tanks (see fig. 1).

Two additional air reservoirs may be installed on the vehicle: the kneeling air tank and emergency/parking brake overrule air tank.

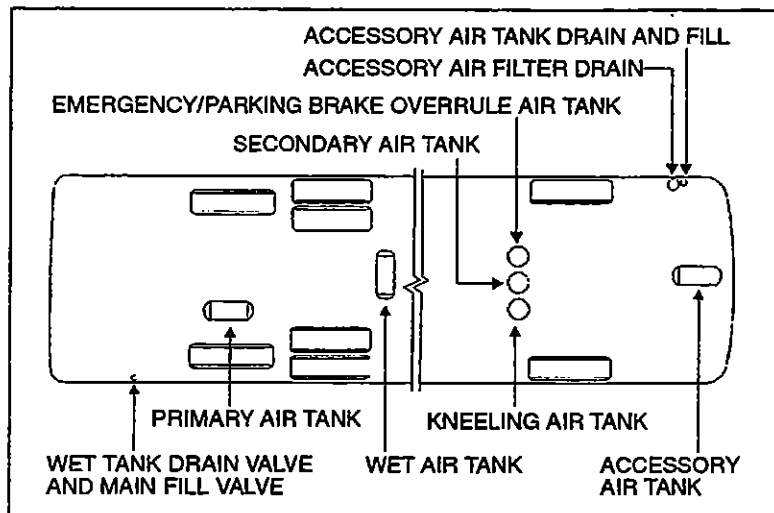

Figure 1

12032

## 2.2 Maintenance

Ensure that both the wet (main) tank and accessory tank are purged during pre-starting inspection. Moreover, a good practice is to purge these reservoirs at the end of every working day. The remaining reservoirs must be purged every 12,500 miles (20 000 km) maximum intervals.

### 2.2.1 Wet (Main) Tank

This reservoir is located over the drive axle in rear wheelhousing, and is provided with bottom drain valve. For daily purge, use the remote drain valve located in engine R.H. compartment (see fig. 2). It is recommended to purge the reservoir by its bottom drain valve every 6,250 miles (10 000 km), or every three months.

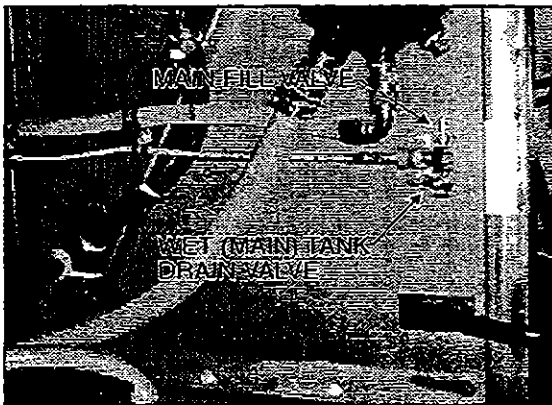

Figure 2

12033

### 2.2.2 Primary Air Tank

This reservoir is located on R.H. side of rear wheelhousing, right over the tag axle, and is provided with a bottom drain valve. It is recommended to purge it every 12,500 miles (20 000 km) or twice a year.

### 2.2.3 Secondary Air Tank

This reservoir is located in front wheelhousing, centered behind steering axle, and is provided with a bottom drain valve. It is recommended to purge it every 12,500 miles (20 000 km) or twice a year.

### 2.2.4 Accessory Air Tank

This reservoir is located in reclining bumper compartment and is provided with a drain valve in front service compartment (see fig. 3). This drain valve could be used for daily purge, and every 12,500 miles (20 000 km) or twice a year.

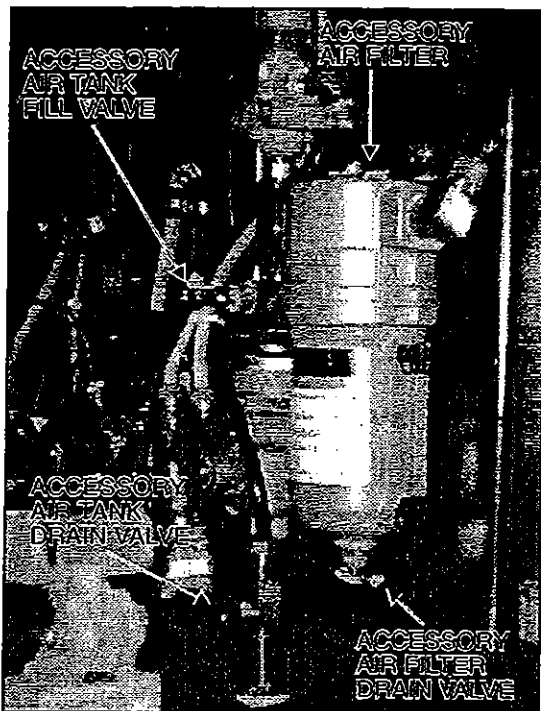

Figure 3

12034

### 2.2.5 Kneeling Air Tank and Emergency/Parking Brake Overrule Air Tank (If Applicable)

These reservoirs are located in front wheelhousing, behind steering axle (R.H. side for kneeling air tank, and L.H. side for emergency/parking brake overrule air tank) and are provided with a bottom drain valve. It is recommended to purge them, with all other reservoirs, every 12,500 miles (20 000 km) or twice a year.

## 3. FILL VALVES

Two external air supply fill valves are installed to supplement air system. Both are similar to those used on tires, so a standard air line may be used to supply air to the system.

**Caution:** No other point should be used to supply air system. The maximum allowable air pressure is 125 psi (860 kPa).

One valve is located in engine compartment, and is accessible through the engine R.H. side door (refer to fig. 2). This valve supplies the whole air

system. The other fill valve is located in steering compartment, and supplies accessories only (refer to fig. 3).

## 4. ACCESSORY AIR FILTER

This filter is located inside the front service compartment (see fig. 3), and its main function consists in straining the air supply of the accessory air reservoir, when it is connected to an external supply line. Ensure filter is purged whenever supplying the system with an external air line, when the sight glass indicates that filter is full, and every 12,500 miles (20 000 km) maximum intervals.

To purge filter, open the drain valve and let the moisture come out, then close the drain valve. The filter serves air-operated accessories. It is located in steering compartment, and is provided with a bottom drain valve (see fig. 3).

### 4.1 Element Replacement

Replace filter element and gasket once every two years, or whenever differential pressure exceeds 15 psi (105 kPa) between both filter inlet and outlet ports, whichever occurs first.

### 4.2 Cleaning

1. Clean filter body and bowl with a warm water and soap solution. Rinse thoroughly with clean water.
2. Blow dry with compressed air making sure the air stream is moisture free and clean. Pay particular attention to the internal passages.
3. Inspect all parts for damage and replace if necessary.

## 5. AIR GAUGES (PRIMARY AND SECONDARY)

The air pressure gauges, located on the central dashboard panel (see "Operator's Manual"), are connected to the DC-4 double check valve, which is located on the R.H. side of the front service compartment. The latter is connected to the air lines running from the primary and secondary air



tanks, as shown on the pneumatic system diagram annexed to this manual.

The vehicle should never be set in motion until the buzzer alarm and warning lights turn off, i.e when air pressure registers at least 66 psi (455 kPa). Moreover, if pressure drops below 66 psi (455 kPa), the "Low air pressure" warning lights will turn on, and the "Low air pressure" buzzer will sound. Stop the vehicle immediately, determine and correct the cause(s) of pressure loss. Check the gauges regularly with an accurate test gauge. Replace the gauge with a new unit if there is a variation of 4 psi (27 kPa) or more in the reading.

## 6. AIR DRYER (SYSTEM SAVER 1000)

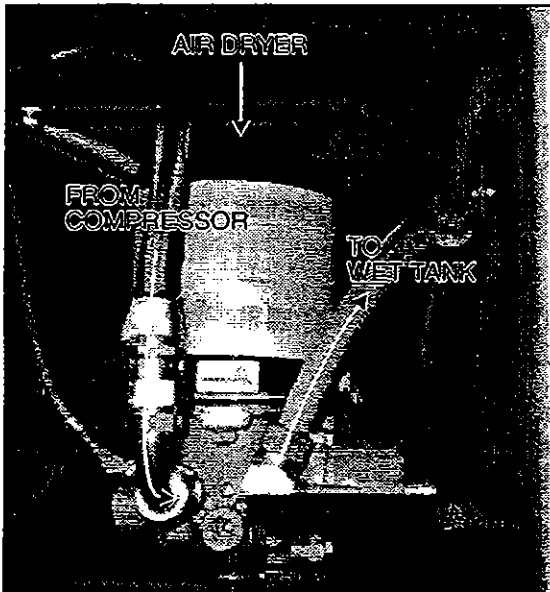

Figure 4

12035

The purpose of the air dryer is to remove moisture that could damage the air system before the air enters the system reservoir. The air dryer also filters the air to remove dirt, compressor oil, and other contaminants that can damage the system. Maintenance and repair information on the air dryer are supplied in the applicable booklet annexed to this section under reference "Maintenance manual 4CC". Air dryer is mounted on the rear subframe immediately over the drive axle (see fig. 4).

## 7. AIR LINES AND HOSES

Copper tubing, nylon-reinforced tubing, and flexible hoses are used to connect the units in the pressurized air system, including air brake system, suspension system, and accessory systems such as door, fresh air damper cylinder, air horns etc. Furthermore, the nylon tubing is color coded to ease identification. Refer to the following table for the complete color identification code. Service instructions for each type of air line are also provided under the applicable headings.

Color	Circuit
Red	Secondary
Green	Primary and Delivery
Yellow	Parking Brake
Blue	Suspension
Black	Accessory
White	Entrance Door

### 7.1 Tubing and Hoses

#### 7.1.1 Copper Tubing

Annealed copper tubing with three-piece compression type fittings are used in the engine compartment where non-flexible hoses are required, but must be heat resistant. Connections should be checked for leakage at least every 6,250 miles (10 000 km), and tightened or replaced if necessary. When replacing copper tubing, the tubing must be free of burrs, copper cuttings, and dirt. Blow out tubing with compressed air. Any of the above-mentioned particles will destroy sealing seats in air control units. New tubing must be the same size as the old one.

Always use new tubing ring when replacing tubing. When tightening tube connector nuts, tighten to the specified torque to ensure an airtight connection (refer to heading "Fitting tightening torques" at the end of this section). Overtightening will cause leakage. Apply SAE 10 oil or spray white grease (Prévost part No. 68-0343) to ball sleeves, tubes, and male threads, then torque to the minimum value and check for leaks. If leaking

## Section 12: BRAKE AND AIR SYSTEM

occurs, back off tube nut about 1/2 turn and retorqued to a higher than minimum value.

### 7.1.2 Nylon Tubing

Nylon tubing is used for air lines in areas where usage of this material is suitable. Nylon tubing is flexible, durable, and weather resistant. When replacing an air line, use nylon tubing only where it has been used previously. Teflon-braided stainless steel hoses used in the engine compartment must be replaced only with similar hoses.

**Caution:** Nylon air lines should be used to replace existing nylon lines only, and must comply with the color identification code to ease pneumatic system troubleshooting.

Nylon air lines must never be routed in areas where temperature could exceed 200 °F (93 °C).

### 7.1.3 Flexible Hoses

A flexible hose is used normally where it is impractical to use copper or nylon tubing due to constant flexing during operation, such as brake chamber hoses or belt tensioner air cylinder hoses. Hose connections should be tested for leakage at least every 6,250 miles (10 000 km), and tightened or replaced if necessary. Any hose which is chafed, worn or kinked should be replaced.

## 7.2 Air Line Serviceability Test

### 7.2.1 Operating Test

If any trouble symptom such as slow brake application or slow brake release indicates a restricted or clogged air line, disconnect the suspected tube or hose at both ends and blow through it to clear the passage. Inspect tubing and hose for partial restriction that may be caused by dents or kinks. If such a condition is found, the tubing or hose should be replaced.

### 7.2.2 Leakage Test

With air system fully charged and the brakes applied, coat all tubing and hose connections with a soapy solution to check for air leakage. No leakage is permitted. Leakage can sometimes be

corrected by tightening the connection. If this fails to correct the leakage, new fittings, nylon tubing, copper tubing, teflon-braided stainless steel and flexible hoses must be installed as applicable.

## 7.3 Maintenance

Inspect all lines for cuts, swelling, kinks or other damage or deterioration. Check for lines being pinched by other components. Retaining clips and ties must be in place. Any support or bracket should be in good condition and mounted firmly in position. Hose spring guards should be in usable condition and not distorted. Particular attention should be given to long lines. Any supporting component (clips, ties, grommets, etc.) must be secured to prevent unnecessary vibrations and eventual loosening of connections. Any leak detected should be attended to. Be sure nylon lines are not near areas of intense heat. Check for any missing grommets or loom material where chafing or cutting may occur. Replace with new material as required. In general, lines should be securely located in position and free from any binding condition which would hinder air flow.

## 8. PRESSURE REGULATING VALVES

### 8.1 Description

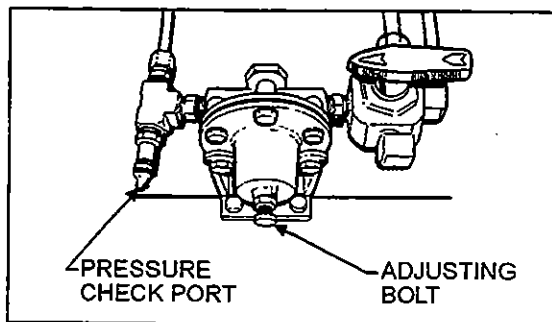

Figure 5

12036

There is one pressure regulating valve for the belt tensioners, and an optional one either for world transmission output retarder or for manual transmission servo-clutch. Refer to figure 5.

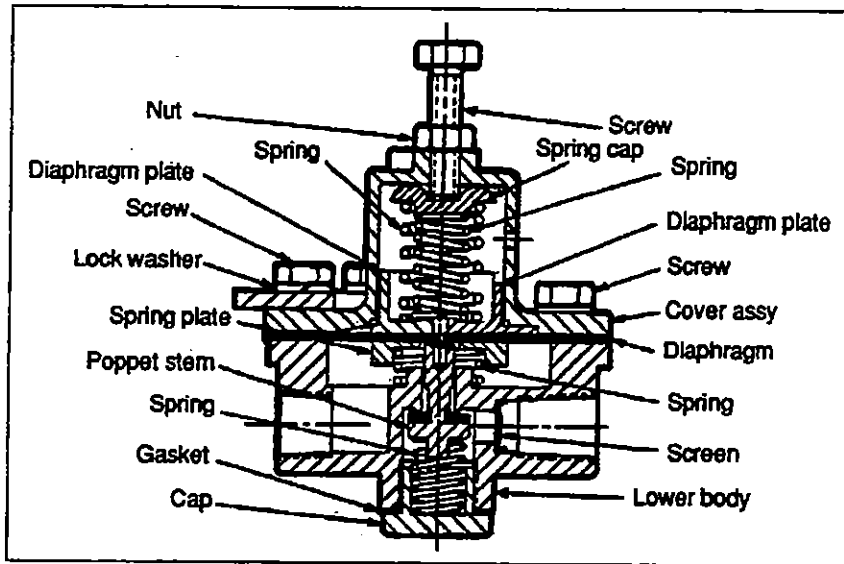

Figure 6

12037

The belt tensioner pressure regulating valve controls pressure in the three belt tensioner cylinders as these latter are parallel mounted. It is located on the structure post at left of the oil reserve tank in engine compartment and is used to limit the air pressure in belt tensioners to  $50 \pm 2$  psi ( $345 \pm 15$  kPa).

The optional one is located in engine compartment and is accessible by the service R.H. side door. It could be used for transmission retarder or for servo-clutch. When used with the transmission retarder, it should be adjusted to  $80 \pm 3$  psi ( $550 \pm 20$  kPa), and when used with the manual transmission servo-clutch, it should be adjusted to 40 psi (275 kPa).

	Air Pressure (psi)	Air Pressure (kPa)
Belt Tensionner	$50 \pm 2$	$345 \pm 15$
Retarder	$80 \pm 3$	$550 \pm 20$
Servo-Clutch	40	275

## 8.2 Maintenance

Every 100,000 miles (160 000 km), or annually, disassemble valve and wash all metal parts in a

cleaning solvent (refer to fig. 6 for details). Examine the diaphragm; if cracked, worn or damaged, replace with new diaphragm. If the valve is excessively grooved or pitted, it should be replaced. Replace any other parts that appear worn or damaged. After valve is assembled, adjust the valve to the specified pressure setting and check for air leakage.

## 8.3 Pressure Setting Procedure

Remove the dust cap from the pressure check port. Attach a pressure gauge at this port and check the pressure reading. If the pressure reading is not correct, it can be adjusted by means of the screw on top of the regulating valve as follows:

1. Loosen the locknut, turn the adjusting screw counterclockwise to decrease pressure approximately 10 psi (70 kPa) below the required pressure.
2. Turn the adjusting screw clockwise to increase the pressure slowly until the required pressure setting is reached. Tighten the locknut.
3. Replace dust cap on the pressure check port.

## 9. DOOR EMERGENCY RELEASE VALVE

The entrance door of the vehicle is provided with two emergency release valves (one inside and one outside the vehicle), for use in the event of possible malfunction of its main control or failure of its internal components. The interior release valve is located on R.H. side of the driver's HVAC unit access panel, and releases pressure from the lock cylinders. The exterior release valve is located in front service compartment, and also releases pressure from the cylinders (for more information on operation, refer to heading "7. Coach Entrance Door" in section 18, "Body"). The door emergency release valve should be checked periodically for leakage by applying a soapy solution to the exhaust ports while the valve is closed. Internal leakage will be evident with the appearance of bubbles. If leakage is noted, or valve fails to operate properly, remove and repair, or replace valve.

### 9.1 Removal and installation

Refer to figure 7 for location of different components.

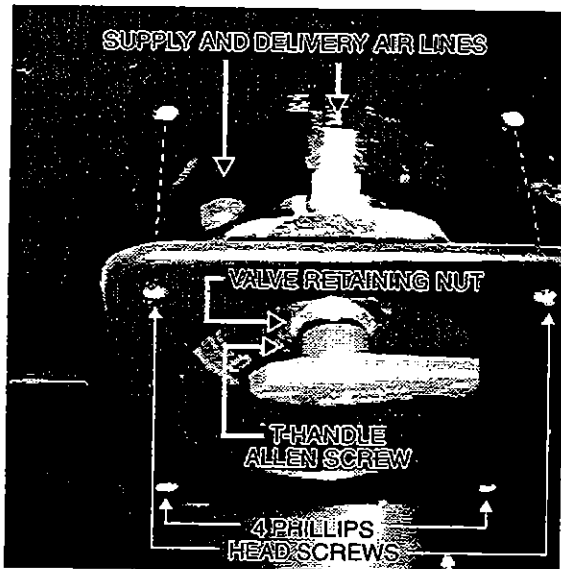

Figure 7

12038

1. Remove the valve T-handle allen screw.

2. Remove the four phillips head screws attaching the emergency release valve plate (interior release valve only).
3. Remove the valve retaining nut.
4. Disconnect the supply and delivery air lines from valve.
5. Repair or replace valve as necessary.

To install, reverse removal procedure.

## 10. AIR SYSTEM COMPONENTS

### 10.1 Air Compressor (TU-FLO 750)

The function of the compressor is to provide and maintain air under pressure to operate devices in brake and air systems. Maintenance and repair information on the TU-FLO 750 air compressor is supplied in the applicable booklet annexed to this section under reference number SD-01-344.

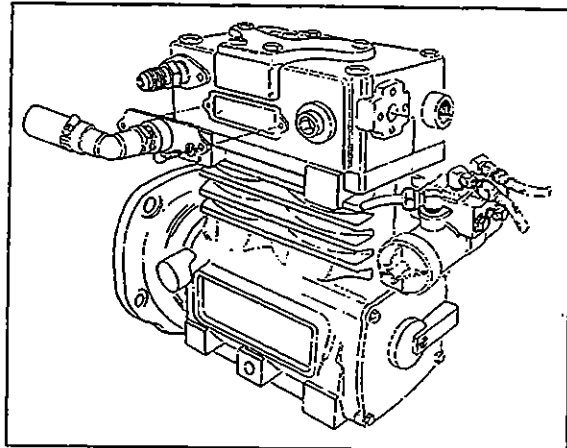

Figure 8: Air Compressor and Governor

12039

#### 10.1.1 Removal and Installation

1. Exhaust compressed air from air system by opening the drain valve of each air reservoir.
2. Drain the engine cooling system and the cylinder head of the compressor.

3. Identify and disconnect all air, coolant and oil lines from the compressor and governor assembly (refer to fig. 8).
4. Remove the four mounting screws, and then the compressor from the engine.

Reverse removal procedure for installation.

## 10.2 Governor (D-2)

The governor is mounted on the air compressor (see fig. 8), its function is to maintain the system pressure between a minimum and a maximum value. Maintenance and repair information on D-2 governor is supplied in the applicable booklet annexed to this section under reference number SD-01-16.

## 10.3 Push-Pull Control Valve (PP-1)

A push-pull control valve mounted on the R.H. lateral console is provided for parking brake application or release. The spring brakes are self-actuated whenever the control valve supply pressure drops below 40 psi (275 kPa). Maintenance and repair information on this valve is supplied in the applicable booklet annexed to this section under reference number SD-03-61.

## 10.4 Flip-Flop Control Valve (TW-1)

A flip-flop control valve mounted on the R.H. lateral console is provided to unload tag axle air springs (and to lift tag axle if vehicle is so equipped) and low-buoy system. It is a manually operated "on-off" valve. Maintenance and repair information on this valve is supplied in the applicable booklet annexed to this section under reference number SD-03-64.

## 10.5 Horn Valve (HV-3)

The horn valve is a simple "on-off" non-exhausting valve, designed specifically for controlling air horn. The horn valve is designed to return to the off position when application force is removed from it.

## 10.6 Dual Brake Application Valve (E-15)

The E-15 dual brake valve is floor mounted, treadle operated type brake valve with two separate supply and delivery circuits.

### 10.6.1 Brake Pedal Adjustment

After brake pedal replacement or repair, adjust the pedal to its proper position according to the following procedure:

Replace the linkage, loosen threaded rod locknuts, and screw or unscrew the threaded adjustment rod in order to obtain a brake pedal inclination corresponding to 45° (refer to fig. 9). Tighten threaded rod locknuts.

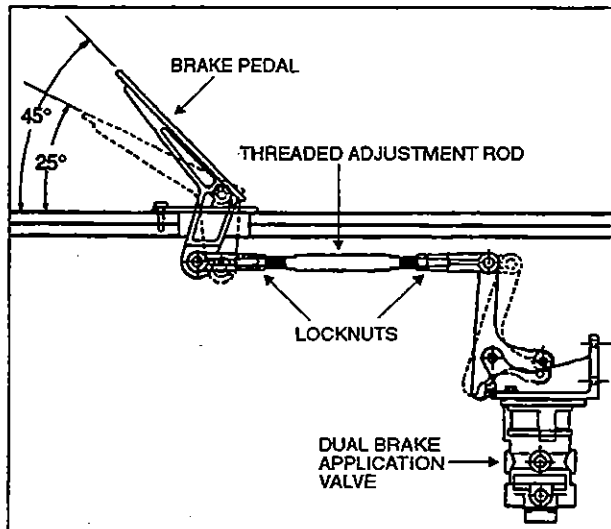

Figure 9

12040

### 10.6.2 Maintenance

Maintenance and repair information on the E-15 dual brake application valve is supplied in the applicable booklet annexed to this section under reference number SD-03-826.

## 10.7 Stoplight Switches

Two electro-pneumatic stoplight switches are mounted on the dual brake application valve (E-15). The upper one is used for the primary air circuit while the lower one is used for the

## Section 12: BRAKE AND AIR SYSTEM

secondary air circuit. Both switches are connected in parallel and have the same purpose, i.e. completing the electrical circuit and lighting the stoplights when a brake application is made. The upper switch is designed to close its contact between 2 psi and 4 psi (14 kPa to 28 kPa), while the lower one closes its contact at 4 psi (28 kPa). The switches are not a serviceable item; if found defective, the complete unit must be replaced.

### 10.8 Brake Relay Valve (R-12)

Three brake relay valves are provided on this vehicle; one is mounted on the drive axle service brake air line, while the other two are mounted on the tag axle service brake air line and act as interlock valves. Maintenance and repair information on these valves is supplied in the applicable booklet annexed to this section under reference number SD-03-31.

### 10.9 Quick Release Valves (QR-1)

Two quick release valves are provided on this vehicle. One is mounted on the front axle service brake air line, while the other is mounted on

the drive axle emergency brake air line. They are responsible for the rapid exhaust of air pressure from brakes, thus decreasing the brake release time. Maintenance and repair information on these valves is supplied in the applicable booklet annexed to this section under reference number SD-03-69.

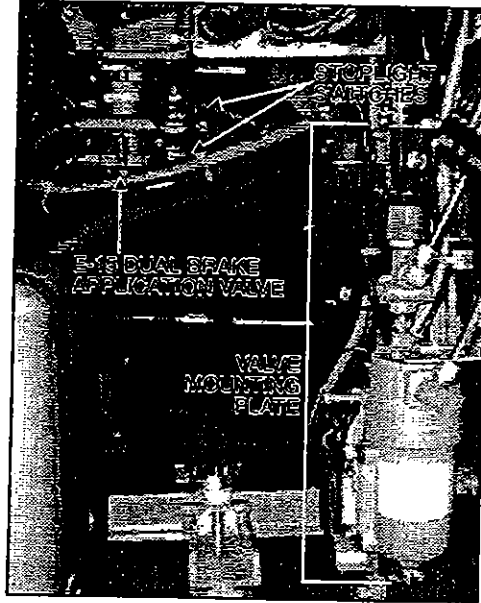

Figure 10

12041

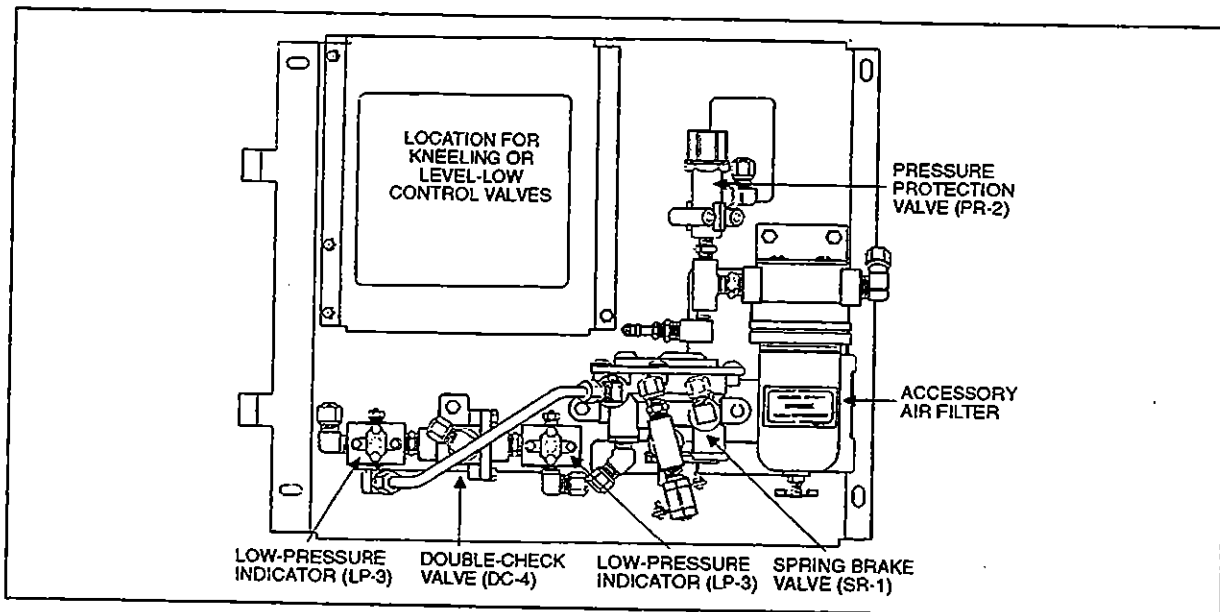

Figure 11

12042

### 10.10 Spring Brake Valve (SR-1)

This valve is installed on the valve mounting plate, which is located on the R.H. side in the front service compartment (see fig. 10 for location, and 11 for details). The function of the SR-1 is to modulate the spring brake through application of the foot brake valve in the event of loss of service brake pressure. Maintenance and repair information on the spring brake valve is supplied in the applicable booklet annexed to this section under reference number SD-03-87.

### 10.11 Pressure Protection Valve (PR-2)

Maintenance and repair information on the pressure protection valve is supplied in the applicable booklet annexed to this section under reference number SD-03-55. This valve is installed on the valve mounting plate, which is located on the R.H. side in the front service compartment (see fig. 10 for location, and fig. 11 for details). The primary function of this valve is to protect the main air system by ensuring that a sufficient air pressure is in the main system at all times (i.e. air delivered to the accessories will be shut off in case of a decrease in pressure). This valve remains closed until a preset pressure is reached (approximately 60 psi (415 kPa)). It then opens and passes air out the delivery port.

### 10.12 Low Pressure Indicators (LP-3)

Maintenance and repair information on the low pressure indicators is supplied in the applicable booklet annexed to this section under reference number SD-06-2. These switches are installed on the valve mounting plate, which is located on the R.H. side in the front service compartment (see fig. 10 for location, and fig. 11 for details). These pressure sensitive electro-pneumatic switches are designed to give an automatic warning to the driver in the event that air pressure in the service brake system is below  $66 \pm 6$  psi ( $455 \pm 40$  kPa). It activates a dash mounted light and buzzer.

### 10.13 Shuttle-Type Double Check Valve (DC-4)

Maintenance and repair information on the shuttle-type double check valve is supplied in the applicable booklet annexed to this section under reference number SD-03-67. This valve is installed on the valve mounting plate, which is located on the R.H. side in the front service compartment (see fig. 10 for location, and fig. 11 for details).

## 11. AIR SYSTEM TROUBLESHOOTING

The following list has been designed to help in troubleshooting some of the most common problems in the air system and their main causes. (For air brake troubleshooting, refer to heading: *Air Brake Troubleshooting* later in this section. For other troubleshooting, refer to the manufacturer's brochures annexed to this section.)

1. **Air pressure doesn't rise to, or doesn't maintain, a normal setting**
  - Defective air gauge (registering incorrectly)
  - Excessive leaking in air system
  - Reservoir drain cock open
  - Governor poorly adjusted or defective
  - Defective compressor
  - Worn compressor or excessive wear on piston and/or ring
2. **Air pressure rises to normal setting too slowly**
  - Excessive leaking in air system
  - Clogged engine air cleaner
  - Worn compressor or excessive wear on piston and/or ring
  - Engine speed too low
3. **Air pressure rises above a normal setting**
  - Defective air gauge (registering incorrectly)
  - Governor poorly adjusted or defective
  - Restriction in line between governor and compressor unloading mechanism

4. Air pressure drops quickly when engine is stopped

- Leaks in compressor discharge valve
- Leaks in governor
- Leaks in air lines
- Leaks in air system valves

## 12. BRAKE OPERATION

The vehicle braking system uses both service and parking air-operated brakes. The air system is divided into two (2) independent circuits to isolate the front axle brakes and the rear axle brakes (drive and tag), thus providing safe brake operation in the event that one circuit of the system fails. The primary circuit is connected to the drive and tag axle brakes, while the secondary circuit is connected to the front axle brakes. The tag axle service brakes operate only when the axle is in the normal driving (loaded) position. The spring-type emergency brakes are mounted on the drive axle, and will apply automatically if primary system pressure falls below 40 psi (276 kPa). The optional parking brake override system can cancel the parking brakes, enabling the driver to move the vehicle to a safe parking place. To operate this system, push down and hold the control knob located on the R.H. lateral console (See "Operator's Manual" for more details).

Furthermore, the brake application sequence, which is increased by a pneumatic relay valve (R-12), will start with the rear axles and be followed by the front axle, thus providing uniform braking on a slippery surface. The vehicle may also be equipped with an Anti-lock Brake System (ABS), which is detailed later in this section.

## 13. AIR BRAKES

### 13.1 Disc Brakes

Knorr-Bremse SB7000 vented-type disc brakes are used on front and tag axles. The front axle discs are actuated by 24 square inch effective area air brake chamber, while on tag axle, the brake chambers have a 16 square inch effective area for service brake and a 16 square inch effective area for emergency/parking brake. The

Knorr-Bremse SB7000 brakes are supplied with automatic clearance (slack) adjusters as standard equipment for easier adjustment. For more information on disc brake components and maintenance, refer to the manufacturer's brochure at the end of this section.

#### 13.1.1 Disc Brake Pads

Brake pads have to be checked on a regular basis depending on the vehicle operation. The remaining thickness of the pads should never be less than 3/32 in (2 mm). To check pad condition without removing the wheel, verify the position of guide bush relatively to guide sleeve (see fig. 12). When guide sleeve is in alignment with guide bush, brake pad thickness has to be checked more precisely with wheel removed. When replacing the brake pads, all four pads on an axle have to be changed at the same time. There is no inner or outer pad, since all pads are the same.

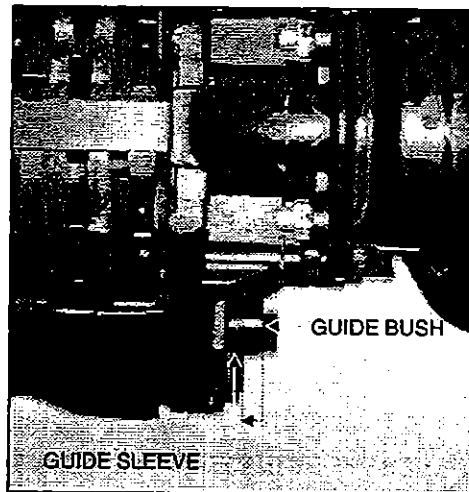

Figure 12

12043

For information on how to change the brake pads, refer to the manufacturer's brochure, annexed to this section.

**Note:** While breaking in new brake pads, avoid long brake applications as well as harsh braking.



## 13.2 Drum Brakes

The drive axle is equipped with Cam-Master, W-Series drum brakes from Rockwell. They're actuated by a 30 square inch effective diaphragm area for service brake, and a 36 square inch area for emergency/parking brake. Automatic slack adjusters from Haldex are provided as standard equipment with these brakes. For information on installation and adjustment of Automatic slack adjusters, refer to Haldex brochure at the end of this section: "Automatic Brake Adjusters, Installation and Maintenance", and refer to fig. 13.



Figure 13

12044

### 13.2.1 Maintenance

Lubricate brake camshaft bushing every 100,000 miles (160 000 km). Grease one fitting on each drive axle drum brake, with good quality lithium-base grease NLGI no.1 or NLGI no.2. Refer to fig.14 for localization of fitting. Lubricate brake spider, camshaft splines, anchor pins and shoe rollers when necessary.

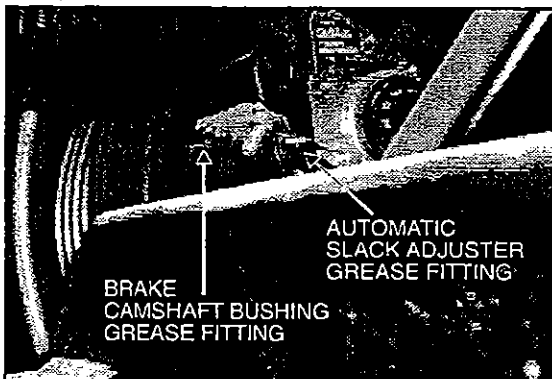

Figure 14

12045

Check brake drums periodically for cracks, severe heat checking, heat spotting, scoring, pitting and distortion. Replace damaged drums. Measure the inside diameter of the drum in several locations with a drum caliper or inside micrometer. Replace the drum if the diameter exceeds the specifications marked on the drum (see fig. 15). For more information on brake drums maintenance, refer to Rockwell's brochure "Field Maintenance Manual Number 23B - Bus and Coach Brakes", annexed to this section.

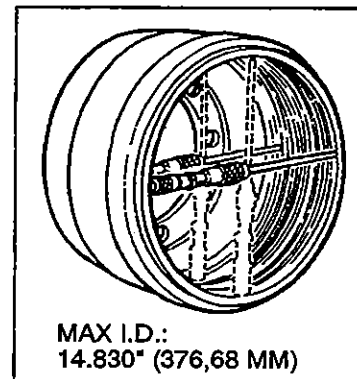

Figure 15

12046

**Caution:** *Prévost does not recommend the turning or reboring of the brake drums because it decreases the strength and heat capacity of the drum. However, if drums must be refaced, the new diameter MUST NOT exceed the maximum inside diameter marked on the drum.*

Grease one fitting on each automatic slack adjuster every 6,250 miles (10 000 km), refer to fig.14 for localization. For more information on maintenance of Haldex's automatic slack adjusters, refer to Haldex brochure at the end of this section: "Automatic Brake Adjusters, Installation and Maintenance".

## 14. RECOMMENDED BRAKE SERVICE PROCEDURES TO REDUCE EXPOSURE TO NON-ASBESTOS FIBER DUST

Most recently manufactured brake linings no longer contain asbestos fibers. Instead of asbestos, these linings contain a variety of ingredients,

## Section 12: BRAKE AND AIR SYSTEM

including glass fibers, mineral wool, aramid fibers, ceramic fibers, and carbon fibers. At present, OSHA (Occupational Safety and Health Administration) does not specifically regulate these non-asbestos fibers, except as nuisance dust. Medical experts do not agree about the potential long-term risks from working with and inhaling non-asbestos fibers. Nonetheless some experts think that long-term exposure to some non-asbestos fibers could cause diseases of the lung, including pneumoconiosis, fibrosis, and cancer. Therefore, lining suppliers recommend that workers use caution to avoid creating and breathing dust when working on brakes that contain non-asbestos fibers.

### **Warning:**

1. *Whenever possible, work on brakes in a separate area away from other operations.*
2. *Always wear a respirator approved by NIOSH (National Institute of Occupational Safety and Health) or MSHA (Mine Safety and Health Administration) during all brake service procedures. Wear the respirator from removal of the wheels through assembly.*
3. *NEVER use compressed air or dry brushing to clean brake parts or assemblies. OSHA recommends that you use cylinders that enclose the brake. These cylinders have vacuums with high efficiency (HEPA (Health and Environment Protection Agency)) filters and workmans' arm sleeves. But, if such equipment is not available, carefully clean parts and assemblies in the open air.*
4. *Clean brake parts and assemblies in the open air. During disassembly, carefully place all parts on the floor to avoid getting dust into the air. Use an industrial vacuum cleaner with an HEPA filter system to clean dust from the brake drums, backing plates and other brake parts. After using the vacuum, remove any remaining dust with a rag soaked in water and wrung until nearly dry.*
5. *Grinding or machining brake linings. If you must grind or machine brake linings, take additional precautions because contact with fiber dust is higher during these operations. In addition to wearing an approved respirator, do such work in an area with exhaust ventilation.*

6. *Cleaning the work area. NEVER use compressed air or dry sweeping to clean the work area. Use an industrial vacuum with an HEPA filter and rags soaked in water and wrung until nearly dry. Dispose of used rags with care to avoid getting dust into the air. Use an approved respirator when emptying vacuum cleaners and handling used rags.*

7. *Worker clean-up. Wash your hands before eating, drinking or smoking. Do not wear your work clothes home. Vacuum your work clothes after use and then launder them separately, without shaking, to prevent fiber dust from getting into the air.*

8. *Material safety data sheets on this product, as required by OSHA, are available from Rockwell.*

## 15. AIR BRAKE TROUBLESHOOTING

The following tests and check lists have been designed to identify the cause(s) of a sluggish performance and/or leaks in the system. These tests require very little time to perform, and give you a general idea of the system condition. Each test is provided with a corresponding check list, that will guide you to the most common causes of problems.

Prior to performing any test, check all air lines for kinks or dents, and hoses for signs of wear, drying out or overheating.

**Warning:** *When working on or around brake system and its related components, the following precautions should be observed.*

1. *Always block vehicle wheels. Stop engine when working under a vehicle. Keep hands away from chamber push rods and slack adjusters as they may apply when system pressure drops.*
2. *Never connect or disconnect a hose or line containing air pressure. It may whip as air escapes. Never remove a component or pipe plug unless you are sure all system pressure has been depleted.*

3. *Never exceed recommended air pressure and always wear safety glasses when working with air pressure. Never look into air jets or direct them at anyone.*

4. *Never attempt to disassemble a component until you have read and understood the recommended procedures. Some components contain powerful springs and injury can result if not properly disassembled. Use only proper tools and observe all precautions pertaining to the use of those tools.*

5. *Always clean connecting piping and/or fittings, and coat pipe threads with teflon pipe sealant before installing any air brake system component.*

## 15.1 Pressure Build-up / Low Pressure Warning / Cutoff Point / Governor Cutout

**CONDITION:** Vehicle parked, wheels chocked

1. Completely drain air reservoirs.
2. Start engine and run at fast idle. Low pressure warning lights should be "On".
3. Start checking pressure at 50 psi (344 kPa).
4. Low pressure warning lights and buzzer should go off at or above 60 psi (415 kPa).
5. At 85 psi (586 kPa), run engine at full rpm, then check that build up time to 100 psi (690 kPa) is 30 seconds or less.
6. Governor cutout. Cuts out at the correct pressure of 120-125 psi (826-861 kPa).
7. Governor cut-in. Reduce service air pressure to governor cut-in. The difference between cut-in and cut-out pressures should not exceed 25 psi (172 kPa).

For common corrections, refer to the following check list.

### 15.1.1 High or Low Warning Cutoff Point

1. Check dash gauge with an accurate test gauge.
2. Repair or replace the defective low pressure indicator switches.

3. Repair or replace buzzer or light bulb, and check wiring.

### 15.1.2 High or Low Governor Cutout Point

1. Check dash gauge with an accurate test gauge.
2. Adjust governor to desired cutout.

OR

3. Repair or replace governor as necessary after checking that compressor unloader mechanism is operating correctly.

### 15.1.3 More Than 30 Seconds to Build-up Pressure from 85 to 100 psi (585 - 690 kPa) at Full Engine RPM

1. Check air gauges on the dashboard with an accurate test gauge.
2. If compressor strainer or inlet line is restricted, clean or replace element or faulty line.
3. If compressor head or discharge line is carbonized or otherwise restricted, clean or replace.
4. If discharge valves are leaking, pull head and correct or replace cylinder head.
5. If drive is slipping, change gear as indicated.
6. If inlet valves are stuck, open or leaking severely, replace unloader kit, inlet valves and/or seats as necessary.
7. If drain cock is found open, close it.
8. If governor leaks when "unloaded", clean or replace inlet valve or replace governor.
9. Listen for air leaks and repair.

**Retest to check all items repaired or replaced.**

## 15.2 Air Supply Reservoir Leakage

**CONDITION:** Full pressure, engine stopped, parking brake applied

1. Allow at least 1 minute for pressure to stabilize.
2. Stop engine, then check air pressure gauge for 2 minutes, and note any pressure drop.

## Section 12: BRAKE AND AIR SYSTEM

3. Pressure drop should not be more than 3 psi (20 kPa) per minute.

For common corrections, refer to the following check list.

### 15.2.1 Excessive Air Loss:

1. With the primary air system at normal operating pressure (95 - 125 psi (655 - 860 kPa)), coat all air line connections and pneumatic components with a water and soap solution. Bubbles will indicate an air leak, and none should be permissible. Repair or replace defective parts.

2. Listen for leaks and correct as required.

Retest to check all items repaired or replaced.

### 15.3 Air Brake Leakage

**CONDITION:** Full pressure, engine stopped, parking brake released

1. Apply foot brake, allow at least 1 minute for pressure to stabilize.
2. Hold down foot valve for 2 minutes while observing air pressure gauge on the dash-board.
3. Pressure drop should not be more than 4 psi (27 kPa) per minute.

For common corrections, refer to the following check list.

#### 15.3.1 Excessive Leakage on Brake Service Side:

1. With the primary air system at normal operating pressure (95 - 125 psi (655 - 860 kPa)) and foot brake applied, coat all air line connections and brake pneumatic components with a water and soap solution. Bubbles will indicate an air leak, and none should be permissible. Repair or replace defective parts.
2. Listen for leaks and correct as required.

Retest to check all items repaired or replaced.

## 16. BRAKE AIR CHAMBER

### 16.1 Description

This vehicle is equipped with "Anchorlock" brake chambers on drive axle, used as a service brake chamber, an emergency brake in case of air pressure loss and a spring-applied parking brake. It consists of two separate air chambers, each having its own diaphragm and push rod. Refer to figures 16 and 17.

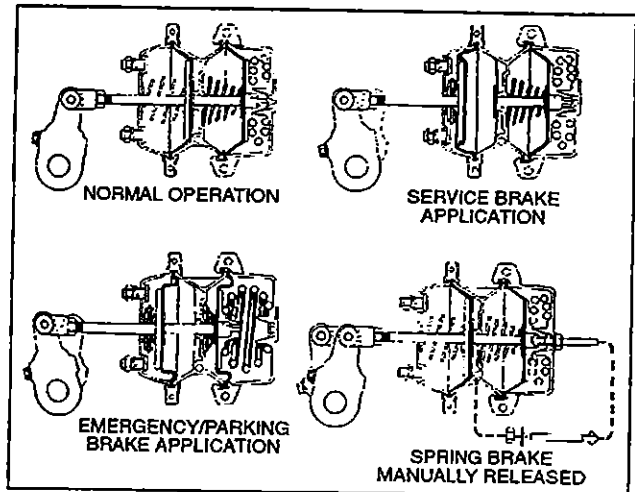

Figure 16

12047

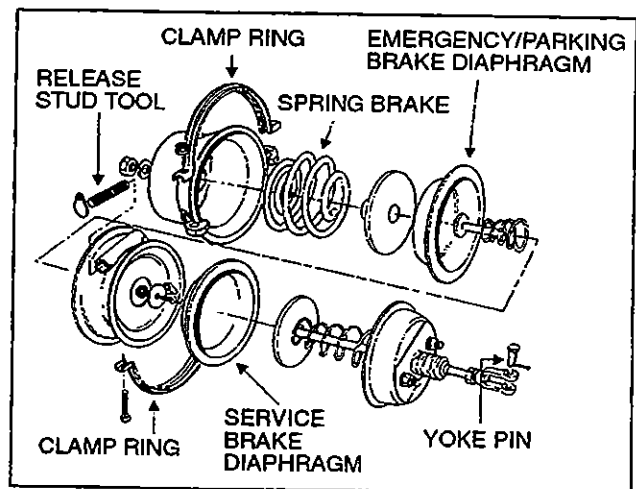

Figure 17

12048

The front and tag axles are equipped with "Knorr-Bremse" brake chambers, used for service brake

on front axle (see fig. 18) and for service and emergency/parking brake on tag axle (see fig. 19).

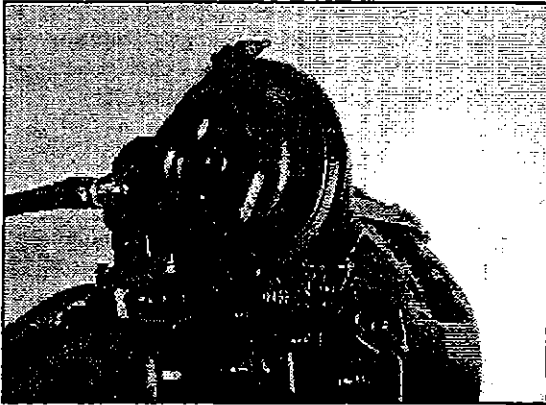

Figure 18: Front Axle Brake Air Chamber 12049

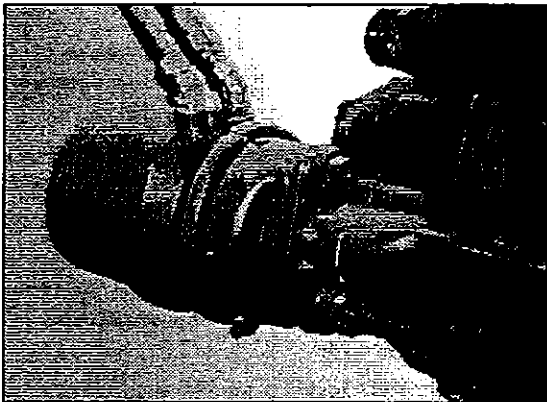

Figure 19: Tag Axle Brake Air Chamber 12050

## 16.2 Maintenance

### 16.2.1 Every 6,250 Miles (10 000 km) Depending on Type of Operation

1. Apply brakes and observe that the push rods move out promptly without binding.
2. Release brakes, and observe that the push rods return promptly and without binding to the released position.
3. Check tightness of mounting nuts. Check that cotter pins are in place.
4. Check all hoses and lines. They should be secure and in good condition.

### 16.2.2 Every Two Years or After 100,000 Miles (160 000 km) Depending on Type of Operation

1. Disassemble and clean all parts.
2. Install new diaphragm or any other part if worn or deteriorated.

**Note:** When the diaphragm, spring, or both are replaced, they should be replaced with the corresponding chamber on the same axle.

### 16.2.3 Airtightness Test

1. Make and hold a full brake application.
2. Coat clamping ring(s) with a soapy solution. If leakage is detected, tighten clamping ring only enough to stop leakage. **Do not overtighten** as this can distort sealing surface or clamping ring. Coat area around push rod hole (loosen boot if necessary). No leakage is permitted. If leakage is detected, the diaphragm must be replaced.

## 16.3 Emergency/Parking Brake Manual Release

**Warning:** Never stand in the axis line of the spring brake chambers, especially when caging the spring.

### 16.3.1 Drive Axle

1. Block the wheels to prevent the vehicle from moving.
2. Remove the release stud tool from its storage place on drive axle brake air chamber.
3. Remove the access plug from the end of the spring chamber, then insert the release stud through the opening. Turn the release stud 1/4 turn (clockwise) to anchor it into the spring plate. Install the flat washer and nut, then turn the nut clockwise to cage the spring. Repeat on the opposite side.

**Warning:** Make sure the release stud is properly anchored in spring plate receptacle prior to caging the spring.

4. To manually reset the emergency/parking brake, turn the nut counterclockwise. Reinstall access plugs on the spring chambers, and release stud tools in their storage places.

### 16.3.2 Tag Axle

1. Block the wheels to prevent the vehicle from moving.
2. Turn the release bolt counterclockwise to cage the power spring (approximately 2.5 inches (6 cm)). Repeat on the opposite side.
3. To manually reset the emergency/parking brake, turn the bolt clockwise.

## 16.4 Removal, Installation and Disassembly

### 16.4.1 Removal

**Warning:** To prevent personal injuries, brakes should be inoperative prior to working on any of their components.

1. Block the wheels to prevent the vehicle from moving.
2. Safely support vehicle at the recommended body jacking points.

To gain access to a given brake air chamber, the corresponding wheel can be removed (refer to Section 13: "Wheels, Hubs and Tires").

3. Exhaust compressed air from air system by opening the drain valve of each reservoir.
4. For the drive and tag axles brake chambers, manually release spring brakes (refer to 16.3 *Emergency/Parking Brake Manual Release* procedure).
5. Disconnect air line(s) from brake chamber.
6. On drive axle, remove the yoke pin connecting brake chamber and slack adjuster.
7. Unbolt and remove the brake chamber from vehicle.

### 16.4.2 Installation

Reverse removal procedure, then check brake adjustment.

**Caution:** Always clean air lines and fittings, and coat pipe threads with teflon pipe sealant before reconnecting air lines.

**Caution:** On Knorr-Bremse air chamber (front and tag axles), do not use molybdenumsulphite combined grease. Use brake chamber with inner sealing, and ensure that the o-ring is in the correct position between the brake caliper and brake chamber.

### 16.4.3 Disassembly

**Warning:** Spring brake chambers (drive and tag axles) contain an extremely high compressive force spring, which can possibly cause serious injury if special precautions are not taken when working around this area. To avoid such injury, the following recommendations must be applied:

1. *Prévost* recommends the installation of a new spring brake chamber if it is found to be defective.
2. Spring brake chamber maintenance and/or repair must be performed by trained and qualified personnel only.
3. Before manually releasing spring brakes, visually check spring brake for cracks and/or corrosion.
4. On "Anchorlock" brake chambers (drive axle), make sure the release stud is properly anchored in spring plate receptacle prior to caging the spring.
5. Never stand in the axis line of the spring brake chambers, especially when caging the spring.

**Warning:** To prevent personal injury, brakes should be inoperative prior to working on any components.

1. Block the wheels to prevent the vehicle from moving.
2. Safely support vehicle at the recommended body jacking points.

To gain access to a given brake air chamber, the corresponding wheel can be removed (refer to Section 13: "Wheels, Hubs and Tires").

3. Exhaust compressed air from air system by opening the drain valve of each reservoir.
4. For the drive and tag axles brake chambers, manually release spring brakes (refer to 16.3 *Emergency/Parking Brake Manual Release* procedure).

5. Remove clamp ring, and remove and discard the existing diaphragm. Install the new diaphragm squarely on body.
6. Reverse the procedure for assembly. Tap clamp ring to ensure proper seating. Check for proper operation before placing vehicle in service.

## 17. ANTI-LOCK BRAKING SYSTEM (ABS)

### 17.1 Description

This device has been designed to ensure stability and steerability of vehicle during braking, and to minimize its stopping distance whatever the road conditions are. On slippery roads and generally in emergency situations, overbraking frequently induces wheel locking. The anti-lock braking system provides maximum braking performance while maintaining adequate steerability on slippery roads.

The ABS continuously monitors the wheel behaviour during braking. Sensors on each wheel of front and drive axles transmit data to a four channel electronic processor which senses when any wheel is about to lock. Modulator valves quickly adjust the brake pressure (up to 5 times per second) to prevent wheel locking. Each wheel is therefore controlled according to the grip available between its tire and the road.

With this device, the vehicle is brought to a halt in the shortest possible time, while remaining stable and under the driver's control.

Since the vehicle braking system has dual circuits, the ABS is also provided with a secondary system should a fault develop in the ABS. Anti-lock systems are fail safe. Should the system cut out due to a malfunction, the braking system reverts to normal non anti-lock controlled operation. But since ABS consists of two diagonally related circuits, only the half system which has sustained damage or other fault is switched off (i.e. wheels return to normal non-ABS braking). The other diagonal half remains under full ABS control.

**Note:** ABS is active on service brake, transmission retarder, Jake brake, but is inactive on emergency/parking brake.

## 17.2 Troubleshooting and Testing

For troubleshooting and testing of the vehicle's anti-lock braking system, refer to "Maintenance Manual No. 28: Anti-Lock Brake Systems For Trucks, Tractors and Buses", at the end of this section.

## 18. ABS COMPONENTS

The main components of the ABS system are listed hereafter. Refer to each component for its specific function in the system and its maintenance.

### 18.1 Electronic Control Unit

#### 18.1.1 Description

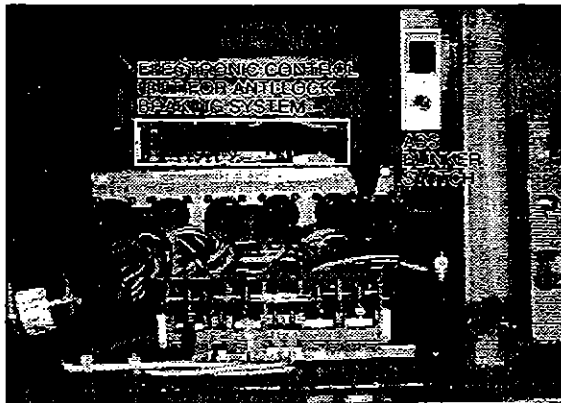

Figure 20

12051

This control unit is located in the front electric compartment (refer to figure 20 for location of E.C.U. and blinker switch). According to the data transmitted by the sensors (number of pulses/sec is proportional to the speed of each wheel), the electronic control unit determines which wheel is accelerating or decelerating. It then establishes a reference speed (average speed) from each wheel data, and compares the speed of each

wheel with this reference speed to determine which wheel is accelerating or decelerating.

As soon as wheel deceleration or wheel slip threshold values are exceeded, the electronic control unit signals a solenoid control valve to limit the excessive brake pressure produced by the driver in the brake chamber.

### **18.1.2 Maintenance**

No specific maintenance is required for the electronic control unit. When it is found to be defective, replace it.

**Caution:** *In order to protect the ABS electronic control unit from voltage surges, always disconnect its connector before performing any welding procedure on vehicle.*

## **18.2 ABS Modulator Valve**

### **18.2.1 Description**

This ABS system is equipped with four modulator valves, located between the brake chamber and the relay valve or quick release valve. Note that there is only one solenoid valve controlling the drive and tag axle wheels on the same side. This is an "On/Off" type valve, i.e., at brake application, the valve exhausts air from the brake chamber when the electronic unit senses that the corresponding wheel speed decreases according to the other wheels.

### **18.2.2 Maintenance**

Like the electronic control unit, no specific maintenance is required for the solenoid control valve.

## **18.3 Sensors**

### **18.3.1 Description**

The sensors are mounted on the front and drive axle wheel hubs. The inductive sensors consist essentially of a permanent magnet with a round pole pin and a coil. The rotation of the toothed wheel alters the magnetic flux picked up by the coil, producing an alternating voltage, the frequency of which is proportional to the wheel

speed. When wheel speed has a tendency to decrease due to the braking coefficient, the magnetic flux produced and sensed afterwards by the electronic control unit will be decreased. Consequently, the electronic control unit will command the solenoid control valve to decrease the pressure at the corresponding brake chamber.

### **18.3.2 Maintenance**

No specific maintenance is required for sensors, except if the sensors have to be removed for axle servicing. In such a case, sensors should be lubricated with a special grease before their reinstallation. Refer to "18.3.3 Installation" for details.

**Note:** *The resistance value, when sensors are checked as a unit, must be equal to 1,75 Kohms. To check the sensors for proper output voltage after the sensors and toothed wheels have been assembled to the axle, connect a suitable AC voltmeter across the output terminals. With the hubs rotating at 30 rpm, the output voltages should read from 50 to 1999 mV to be acceptable.*

### **18.3.3 Installation**

The following procedure deals with sensor installation on the axle wheel hubs. Read procedure carefully before reinstalling a sensor, as its installation must comply with operational tolerances and specifications.

1. Dip clamping bush into the special grease (Prévost part number #68-0460), press clamping bush and insert in the bushing on hub.

**Caution:** *Use only this type of grease on the sensors.*

2. Install sensor inside the clamping bush. Push on assembly to seat it on the pulse wheel. Ensure mounting is rigid, as it is an important criteria for an adequate sensor operation.

**Note:** *This installation should be of the "press fit" type.*



## 18.4 Clamping Bush

### 18.4.1 Description

The clamping bush retains the sensor in its mounting bracket close to the toothed pulse wheel. The gap between the sensor end and teeth is set automatically by pushing the sensor in this bush hard up against the pole wheel, and the latter knocks back the sensor to its adjusted position.

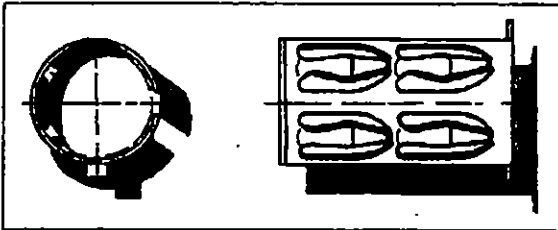

Figure 21: Clamping Bush

12052

### 18.4.2 Maintenance

The clamping bush requires no specific maintenance.

## 19. FITTING TIGHTENING TORQUES

1. 45° Flare and Inverted Flare: Tighten assembly with a wrench until a solid feeling is encountered. From that point, tighten 1/6 turn.

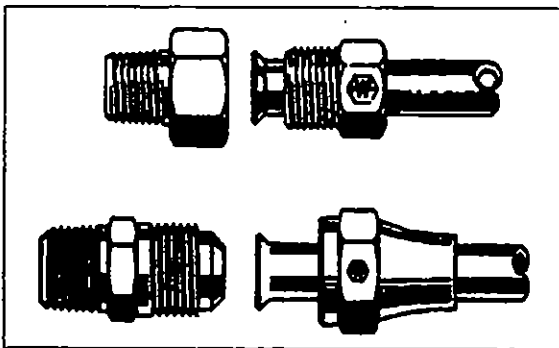

Figure 22

12053

2. Compression: Tighten nut hand tight. From that point, tighten with a wrench the number of turns indicated in the chart hereafter.

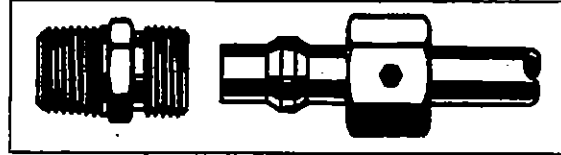

Figure 23

12054

Fitting size	Pipe diameter (inch)	Number of additional turns required following manual tightening
2	1/8	1 1/4
3	3/16	1 1/4
4	1/4	1 1/4
5	5/16	1 3/4
6	3/8	2 1/4
8	1/2	2 1/4
10	5/8	2 1/4
12	3/4	2 1/4
16	1	2 1/4

3. NTA-type Plastic Tubing: Tighten nut hand tight. From that point, tighten with a wrench the number of turns indicated in the chart hereafter.

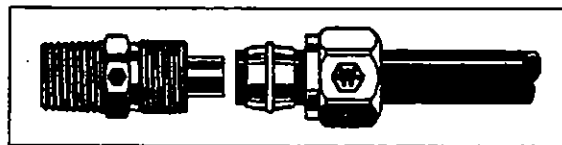

Figure 24

12055

Tubing diameter (inch)	Number of additional turns required following manual tightening
1/4	3
3/8 to 1/2	4
5/8 to 3/4	3 1/2

**Section 12: BRAKE AND AIR SYSTEM**

4. **AB-type Copper Piping:** Tighten nut hand tight. From that point, tighten with a wrench the number of turns indicated in the chart hereafter.

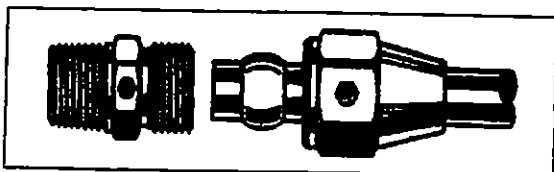

Figure 25

12056

Piping diameter (inch)	Number of additional turns required following manual tightening
1/4, 3/8, 1/2	2
5/8, 3/4	3

5. **Piping Tightening:** All connections must be hand tightened. From that point, tighten a minimum of 2 1/2 additional turns.

**20. SPECIFICATIONS**

**AIR COMPRESSOR**

Make ..... Bendix Westinghouse  
 Model ..... Tu-Flo 750  
 Capacity (at 1250 rpm) ..... 16.5 cfm (0,467 m³/min)  
 Supplier number ..... 107812  
 Prévost number ..... 64-1190

**GOVERNOR**

Make ..... Bendix Westinghouse  
 Model ..... D-2  
 Cut-in pressure ..... 95-105 psi (655-724 kPa)  
 Cutout pressure ..... 120-125 psi (827-861 kPa)  
 Supplier number ..... 284358  
 Prévost number ..... 64-0964

**PUSH-PULL CONTROL VALVE**

(Parking Brakes)

Make ..... Bendix Westinghouse  
 Model ..... PP-1  
 Automatic release pressure  
 ..... 40 psi (275 kPa) nominal  
 Supplier number ..... 287325  
 Prévost number ..... 64-1128

**FLIP-FLOP CONTROL VALVE**

Make ..... Bendix Westinghouse  
 Model ..... TW-1  
 Type ..... On-Off  
 Supplier number ..... 229635  
 Prévost number ..... 64-0136

**DUAL BRAKE APPLICATION VALVE**

Make ..... Bendix Westinghouse  
 Model ..... E-15  
 Supplier number ..... 109174  
 Prévost number ..... 64-1257

**STOPLIGHT SWITCHES**

Make ..... Bendix Westinghouse  
 Model ..... SL-5  
 Contact close (ascending pressure)  
 ..... 6 psi (41,4 kPa)  
 Supplier number ..... 286392  
 Prévost number ..... 64-0852

**BRAKE RELAY VALVES**

Make ..... Bendix Westinghouse  
 Model ..... R-12H  
 Supplier number ..... 102852  
 Prévost number ..... 64-1088

**QUICK RELEASE VALVE**

Make ..... Bendix Westinghouse  
 Model ..... QR-1  
 Supplier number ..... 229859  
 Prévost number ..... 64-1014

**SPRING BRAKE VALVE**

Make ..... Bendix Westinghouse  
 Model ..... SR-1  
 Supplier number ..... 286364  
 Prévost number ..... 64-0870

**PRESSURE PROTECTION VALVE**

Make ..... Bendix Westinghouse  
 Model ..... PR-2  
 Nominal closing pressure ..... 60 psi (415 kPa)  
 Supplier number ..... 277226  
 Prévost number ..... 64-0439

**LOW PRESSURE INDICATORS**

Make ..... Bendix Westinghouse  
 Model ..... LP-3  
 Contact close ..... 66 psi (455 kPa)  
 Supplier number ..... 288522  
 Prévost number ..... 64-0975

**SHUTTLE-TYPE DOUBLE CHECK VALVE**

Make ..... Bendix Westinghouse  
 Model ..... DC-4  
 Supplier number ..... 277988  
 Prévost number ..... 64-1015

**AIR DRYER**

Make ..... Rockell Wabco  
 Model ..... System Saver 1000  
 Heater consumption ..... 100 watts  
 Supplier number ..... S 432 413 0020  
 Prévost number ..... 64-1277  
 Desiccant cartridge kit supplier number  
 ..... S 432 923 2  
 Desiccant cartridge kit Prévost number  
 ..... 64-1278

**AIR PRESSURE REGULATOR**

Make ..... Williams Air Controls  
 Adjustable output range  
 ..... 0-80/85 psi (0-552/586 kPa)  
 Recommended pressure setting  
 ..... 75 psi (517 kPa)  
 Supplier number ..... WM-279-1  
 Prévost number ..... 64-0938

**PNEUMATIC AIR FILTER**

Make ..... Norgren  
 Type ..... with manual drain  
 Supplier number ..... F12-300-PIDA  
 Prévost number ..... 64-1251

**FRONT AXLE BRAKE CHAMBERS**

Make ..... Knorr Bremse  
 Type ..... 24  
 Effective diaphragm area .. 24 sq.in. (154,8 sq.cm)  
 Supplier number ..... BS 3517 II/31651  
 Prévost number ..... 64-1309

**DRIVE AXLE BRAKE CHAMBERS**

Make ..... Anchorlock division  
 Type ..... 30-36  
 Effective diaphragm area  
 ..... 30 sq.in (193,5 sq.cm) as service  
 ..... 36 sq.in (232,3 sq.cm) as emergency  
 Supplier number ..... 3036GC164318  
 Prévost number ..... 64-1181

**TAG AXLE BRAKE CHAMBERS**

Make ..... Knorr Bremse  
 Type ..... 16/16  
 Effective diaphragm area  
 ..... 16 sq.in. (103,2 sq.cm) as service  
 ..... 16 sq.in. (103,2 sq.cm) as emergency  
 Supplier number ..... 11/18224/V1-BS9396  
 Prévost number ..... 64-1308

**AUTOMATIC SLACK ADJUSTER  
(DRIVE AXLE)**

Make ..... Haldex Corporation  
 Supplier number ..... 419-10585  
 Prévost number ..... 62-1523

**SOLENOID CONTROL VALVE  
(ANTI-LOCK BRAKING SYSTEM)**

Make ..... Rockwell Wabco  
 Voltage ..... 24 V  
 Supplier number ..... 472 195 006 0  
 Prévost number ..... 64-1097

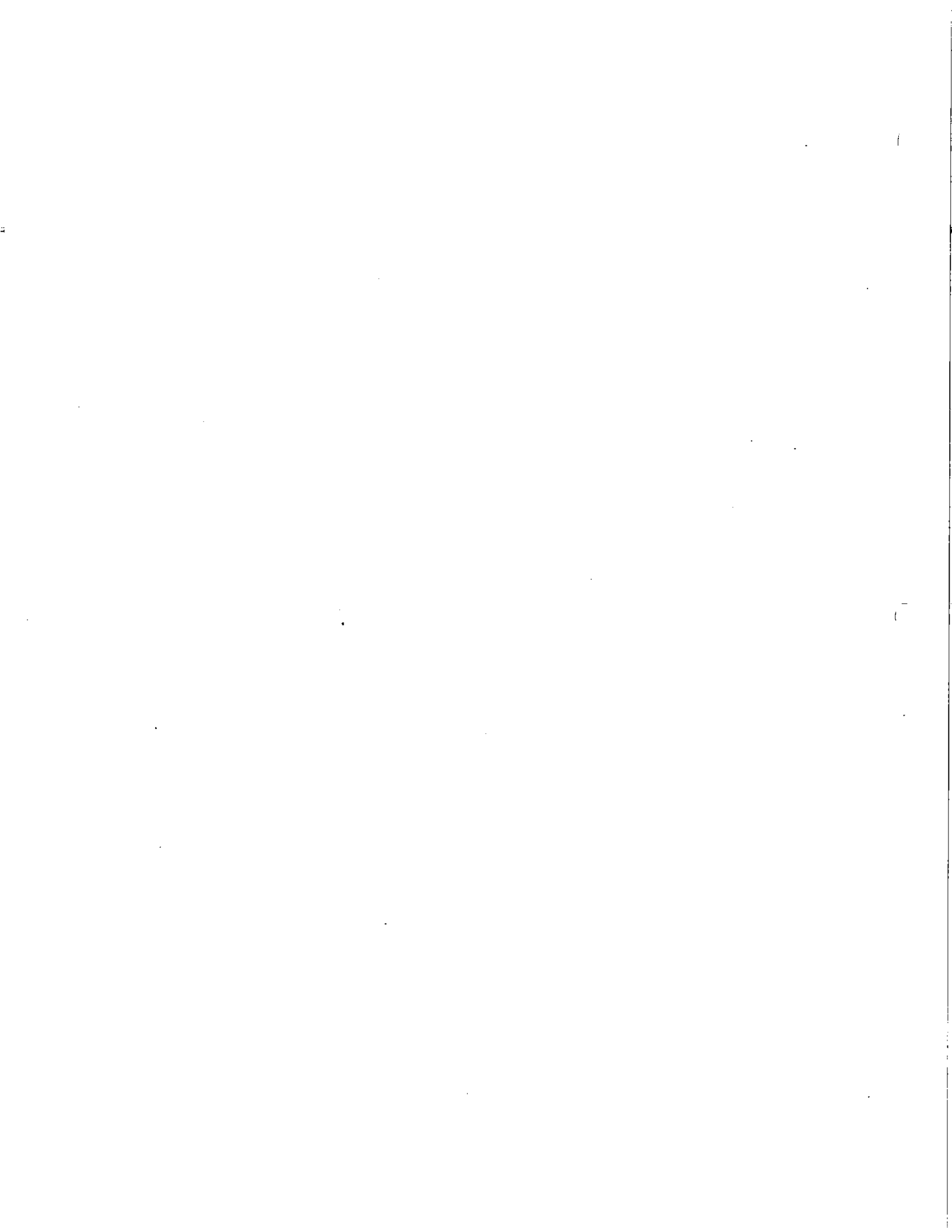



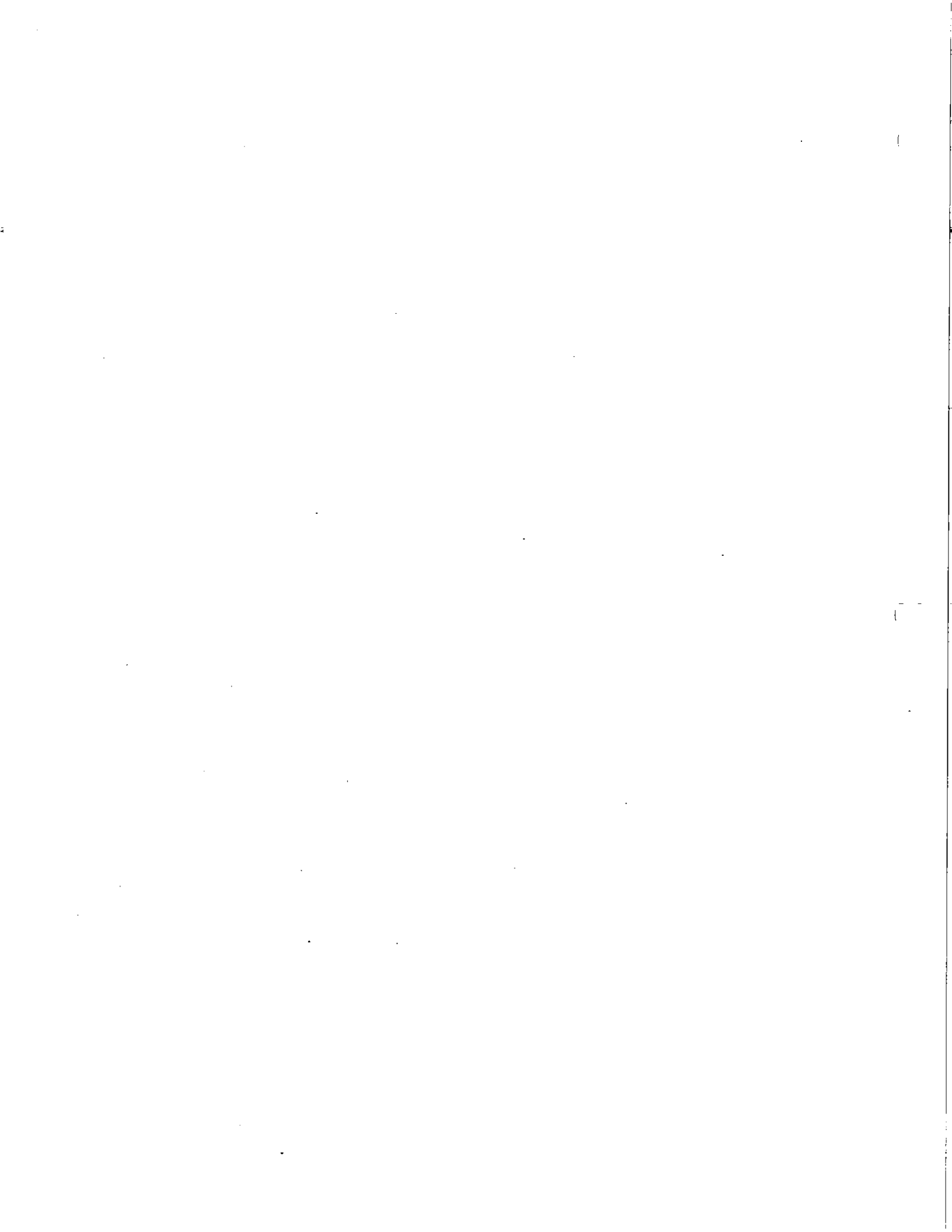

# Section 13: WHEELS, HUBS & TIRES

## CONTENTS

1. WHEELS AND TIRES.....	2
1.1 Description.....	2
2. WHEEL MAINTENANCE.....	2
3. SINGLE WHEEL .....	2
3.1 Removal.....	2
3.2 Installation.....	3
3.3 Inspection.....	3
4. DUAL WHEELS.....	3
4.1 Removal.....	3
4.1.1 Outer Wheel.....	3
4.1.2 Inner Wheel.....	3
4.2 Installation.....	3
4.2.1 Inner Wheel.....	3
4.2.2 Outer Wheel.....	3
4.3 Inspection .....	3
5. CORROSION PROTECTION OF ALUMINUM WHEELS .....	4
6. CHECKING FOR DISTORTED WHEEL ON VEHICLE .....	4
7. WHEEL STUDS .....	5
7.1 Drive Axle.....	5
7.2 Front and Tag Axles .....	5
8. SPARE WHEEL AND TIRE (if applicable) .....	5
9. REMOVING SPARE WHEEL AND TIRE FROM COMPARTMENT .....	6
10. SPARE WHEEL AND TIRE MAINTENANCE .....	6
11. FRONT AND TAG AXLE WHEEL HUBS.....	6
11.1 Grease Type Wheel Hubs.....	6
11.1.1 Recommended Greases.....	6
11.1.2 Routine Maintenance .....	6
11.1.3 Hub Bearing Inspection .....	6
11.1.4 To Remove Hub Unit .....	7
11.1.5 To Assemble the Hub .....	7
11.2 Oil Type Wheel Hubs.....	7
11.2.1 Hub Bearing Maintenance .....	7
12. DRIVE AXLE WHEEL HUBS.....	7
12.1 Description.....	7
12.2 Bearing Adjustment .....	7
12.3 Disassembly and Repair .....	8
13. TIRE MAINTENANCE.....	8
13.1 Recommended Tire Inflation Pressure (Cold) .....	9
13.2 Tire Matching.....	9
13.3 Wheel and Tire Balancing .....	10
13.4 Tire Rotation .....	10

## 1. WHEELS AND TIRES

### 1.1 Description

Where the vehicle is provided with stud-mounted wheels, wheel studs and nuts on the left side of the vehicle have left-hand threads whereas those on the right side have right-hand threads. If equipped with hub-mounted wheels, all studs and nuts have right-hand threads. Either disc steel wheels or optional aluminium-polished wheels may be installed on the vehicle. Both are mounted with radial tubeless tires.

Both steel and aluminum wheel dimensions are 22.50 X 9 inches (571.5 X 228.6 mm) for the following recommended tire dimensions (in order of preference):

315/80 R 22.5  
12.75 R 22.5  
1200 R 22.5

## 2. WHEEL MAINTENANCE

Wheel maintenance consists of periodic inspections to ensure that wheel nuts are tightened to the proper torque. In the case of a new vehicle, or after a wheel installation, stud nuts should be tightened every 100 miles (160 km) for the first 500 miles (800 km) to allow setting in of clamping surfaces.

Wheel studs and nuts must be kept free from grease and oil. No lubricant whatsoever should be used. Cleanliness of the wheel and its rotor or brake drum mating surfaces is important for proper wheel mounting.

It is also important that wheel stud nuts be tightened alternately on opposite sides of the wheel. Refer to Figure 1 for the suggested tightening sequence.

However, for hub mounted wheels, it is recommended to add some rust protection lubricant on the pilot diameter of the hub (only to facilitate future removal).

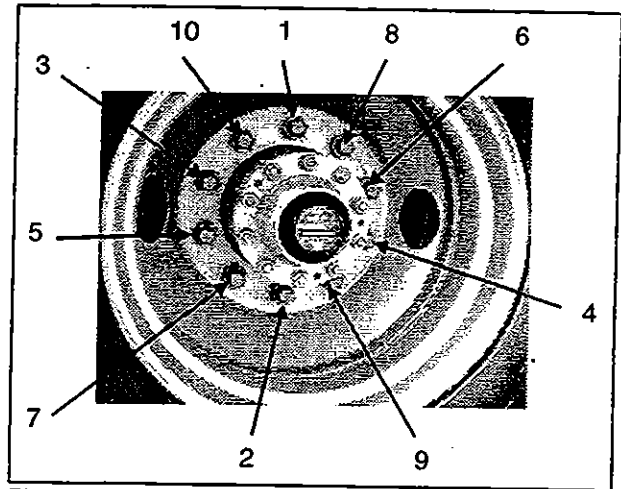

Figure 1: Tightening Sequence

OE18B404

## 3. SINGLE WHEEL

### 3.1 Removal

1. Stop engine and apply parking brake.
2. Loosen wheel nuts about one turn (do not remove the nuts). (This is not necessary if equipped with hydraulic gun.)

**Note:** For stud-mounted wheels, turn nuts counterclockwise for R.H. side and clockwise for the L.H. side. For hub-mounted wheels, turn nuts counterclockwise on both side of the vehicle.

3. Raise the vehicle by its jacking points on the body. See Section 18, "Body", under heading "Vehicle Jacking Points".
4. Unscrew wheel hex stud nuts and remove the wheel.



### 3.2 Installation

1. Screw in the hex stud nuts (refer to Figure 1 for sequence) so that wheel will position itself concentrically with hub. This is important, otherwise wheel may be eccentric with hub and will not run straight. In this initial step, slightly tighten the nuts to correctly position the wheel.
2. Tighten stud nuts progressively as shown in Figure 1. The final tightening should be done with a torque wrench. Tighten stud nuts to 450 - 500 lbf•ft (610 - 680 N•m) for aluminum as well as steel wheel.

### 3.3 Inspection

Repeat step 2 in previous paragraph.

## 4. DUAL WHEELS

### 4.1 Removal

#### 4.1.1 Outer Wheel

Unscrew the hex stud nuts, using the Single Wheel Removal procedure described previously, paragraph 3.1.

#### 4.1.2 Inner Wheel

1. Unscrew inner cap nuts.
2. Remove inner wheel.

### 4.2 Installation

#### 4.2.1 Inner Wheel

1. Screw in the inner cap nuts (shown in Fig. 2) and refer to Figure 1 for sequence, so that wheel will position itself concentrically with hub.

2. Tighten inner cap nuts progressively according to sequence shown in Figure 1. The final tightening should be done with a torque wrench. Tighten inner cap nuts to 450 - 500 lbf•ft (610 - 680 N•m) for aluminum as well as steel wheel.

#### 4.2.2 Outer Wheel

Tighten the hex head nuts (shown in Fig. 2) using the single wheel installation procedure described previously.

### 4.3 Inspection

1. Loosen a hex head nut three turns (Fig. 2).
2. Tighten the inner cap nut to the correct torque (450 - 500 lbf•ft [610 - 680 N•m]).
3. Tighten the hex head nut to the correct torque (450 - 500 lbf•ft [610 - 680 N•m]).
4. Repeat the 3 previous steps for each of the 10 "hex head nut - inner cap nut assemblies" according to the tightening sequence in Figure 1.

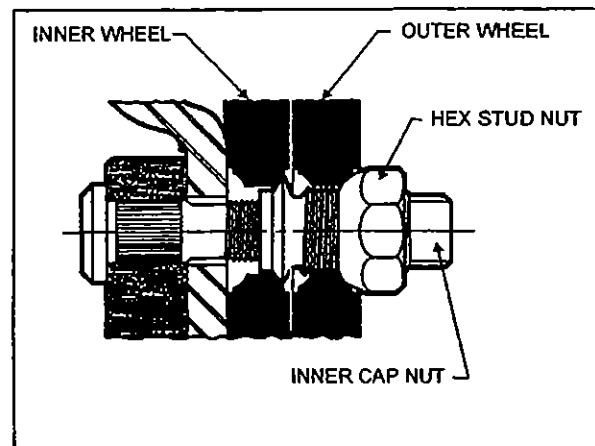

Figure 2: Dual Wheel Installation

MAXE1302

## Section 13: WHEELS, HUBS & TIRES

---

**Caution:** Do not attempt to tighten an inner cap nut without having previously loosened the hex head nut.

**Note:** When mounting rear dual wheels, care should be taken to position the tire valve stems 180° apart to access both inner and outer tire valves.

### 5. CORROSION PROTECTION OF ALUMINUM WHEELS

1. Clean wheels often by means of a high pressure water jet. Cleaning may be accelerated with mild soap. Do not use concentrated alkaline cleaning products.
2. When tire is removed, clean and inspect wheel completely. Remove dirt and corrosion on rim by means of a wire brush. Do not use a wire brush on the outer surface of the wheel.
3. The following measures should be taken to maintain original appearance of the aluminum wheels:
  - Use a sponge, a soft cloth, or a soft fiber brush, with a mild soap and warm water solution to wash the outer wheel surfaces.
  - Rinse thoroughly with clean water.
  - Wipe and dry thoroughly to prevent water stains.
  - Wax surface with "Simonize Body Guard", "Dupont 7 New Car Wax", or an equivalent product.
  - Clean aluminum wheels as required to maintain original look.

**Warning:** Wheel surfaces may have sharp or cutting edges which may cause injury to the hands. To prevent contact with sharp edges, it is strongly recommended to wear rubber gloves when washing or polishing wheels.

### 6. CHECKING FOR DISTORTED WHEEL ON VEHICLE

1. Slightly raise axle to be checked and place a safety support underneath.
2. Check the rim for distortion. Install a dial gauge as shown in Figure 3, then rotate the wheel one full turn. As the wheel turns, note any variation on the dial gauge.

**Caution:** Take care not to damage the dial gauge as it may interfere with the balancing weights on the wheel.

3. The variation should not exceed 0.125 inch (3,2 mm). If the rim is distorted beyond this dimension, the wheel must be replaced.
4. If doubt exists whether wheel or hub is distorted, hub may be checked as follows: Replace the existing wheel with a wheel known to be correct. Revolve the wheel and proceed with the previously mentioned tests. If tests are within limits, the hub is satisfactory, but the wheel is distorted.

**Caution:** NEVER STRAIGHTEN ALUMINUM WHEELS. Never heat aluminum wheels for the purpose of repairing damages incurred after hitting a curb or resulting from other causes. The special alloy in wheels has been heat treated, and any uncontrolled heating could alter the wheel structure. Furthermore, never weld aluminum-forged wheels for any reason whatsoever.

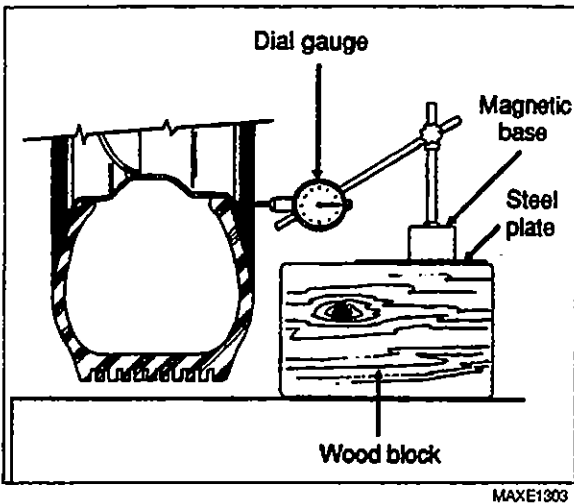

MAXE1303

Figure 3: Suggested Dial Gauge Installation

## 7. WHEEL STUDS

Stripped threads may be the result of excessive torquing, or a result of damage during wheel installation, when placing the wheel over the studs. Where a damaged thread is discovered, the stud must be replaced. Broken studs are a direct result of operating with loose stud nuts or improperly seated wheels. When a broken stud is replaced, the adjacent studs on each side of the broken stud must also be replaced because they could have been subject to excessive strain and may have become fatigued.

When installing wheel studs to hubs, check nuts retaining the wheel stud to wheel hub and if they are deformed, damaged or severely corroded, install new parts. Install nut (and washer where applicable) to new stud and torque to 110 - 130 lbf•ft (150 - 177 N•m) for studs mounted on front and tag axle wheel hubs and torque to 450 - 500 lbf•ft (610 - 680 N•m) for those mounted on drive axle wheel hubs.

### 7.1 Drive Axle

Wheel can be mounted on the drive axle with studs (3/4"-16 thread) or hub mounted (7/8"-14 thread) and with the inner cap nut (1-1/8"-16 thread).

## 7.2 Front and Tag Axles

Wheel can be mounted on tag axle with studs (1-1/8"-16 thread) or hub mounted (7/8"-14 thread).

**Note:** Wheel studs and nuts must be kept free from grease and oil. No lubricant whatsoever should be used.

## 8. SPARE WHEEL AND TIRE (if applicable)

In the case of H3 coaches, the spare wheel and tire are stored in a compartment directly behind the reclining front bumper. Access is reached by unscrewing nuts located at each extremity under the bumper, then by pushing them upwards. Lower bumper slowly as it is quite heavy (Fig. 4).

There is no spare wheel in the case of a converted vehicle. An air shutter is located behind the reclining front bumper. Access is obtained by pressing a latch located in the middle and upper part of the bumper air inlet.

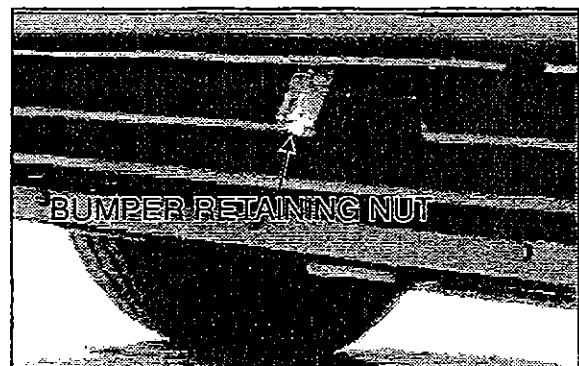

Figure 4: Front Bumper - H3 Coaches

18057

**Note:** It is recommended that two people perform the above operation.

**Warning:** This compartment has not been designed for storage. Never leave any loose objects in this area as it may interfere with steering linkage mechanism.

## 9. REMOVING SPARE WHEEL AND TIRE FROM COMPARTMENT

To pull out the spare wheel and tire, open reclining bumper according to previous instructions. Loosen and turn buckle of the holding chain to release the wheel and dolly assembly. Open the front service compartment, unscrew the wing nut retaining the support and rail extension assembly, then pull out the assembly. Fix it by matching its two holes to the corresponding mounting pins located in front center of spare tire compartment. Pull out spare wheel using strap as illustrated in Figure 5. Remove tire covering, then separate spare wheel from its dolly by unscrewing the two mounting wing nuts.

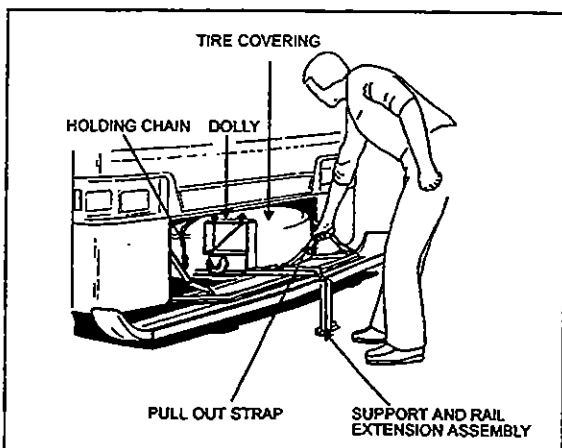

Figure 5: Spare Wheel Installation

MA3E1304

**Note:** Reinstall support and rail extension assembly and fix tire with loading chain before moving vehicle.

**Caution:** Check that the bumper is safely hooked in place, and that retaining nuts are firmly tightened after bumper compartment has been closed.

**Note:** The jack and wheel nut wrench are stored in the right side baggage compartment.

## 10. SPARE WHEEL AND TIRE MAINTENANCE

Maintenance of the spare wheel and tire consists in ensuring that tire inflation pressure is the same as the tire on the coach which has the highest inflation pressure (refer to Recommended Tire Inflation Pressure (cold) in this section). Inspect rim to ensure that there is no important corrosion, check if spare wheel cover is in good condition and check that spare tire is securely fastened in compartment.

**Caution:** If the spare wheel and tire must be installed, deflate the tire in accordance with recommended pressure.

## 11. FRONT AND TAG AXLE WHEEL HUBS

Two types of axle wheel hubs are available. One is lubricated with grease and the other is lubricated with oil.

### 11.1 Grease Type Wheel Hubs

Front and tag axle wheel hubs and hub bearings need to be cleaned and greased every 50,000 miles (80 000 km) or once a year, whichever comes first.

#### 11.1.1 Recommended Greases

A good quality lithium-base grease NLGI No. 1 and 2 are recommended.

#### 11.1.2 Routine Maintenance

#### 11.1.3 Hub Bearing Inspection

1. An inspection should be made after the first 3,000 miles (4 800 km) and then at intervals of 25,000 miles (40 000 km). When the wheels are raised, they should revolve quite freely without roughness.

2. Hub bearings should have a slight end movement with the limits 0.0005 inch to 0.002 inch when rocked forward and backwards on axle stub. See "To Assemble the Hub" in this section.

#### 11.1.4 To Remove Hub Unit

Refer to "GKN Parts and Service Manual for Axles, Manual No. 1604", Issue A, Section B, annexed to the end of Section 10, "Front Axle".

#### 11.1.5 To Assemble the Hub

Refer to "GKN Parts and Service Manual for Axles, Manual No. 1604", Issue A, Section B, annexed to the end of Section 10, "Front Axle".

### 11.2 Oil Type Wheel Hubs

#### 11.2.1 Hub Bearing Maintenance

If applicable, the front and tag axle wheel hubs use oil lubrication which eliminates periodic grease repacking of the hubs. A sight glass is provided for convenient check of oil level. Oil level should be checked daily and must be maintained to the level mark in the sight glass. If oil is not visible through the sight glass, general purpose gear lubricant SAE 90 (A.P.I. spec. GL5) must be added by removing the snap plug in center of the hub cap to bring oil to the correct level. To check oil level after vehicle has been driven, wait at least 15 minutes to ensure that oil has settled.

**Caution:** *Hub oil fill cap is provided with a very small vent hole. Occasionally insert a small tip to avoid hole restriction, as it prevents overpressure in bearing housing.*

## 12. DRIVE AXLE WHEEL HUBS

### 12.1 Description

Drive wheels use a single oil-seal assembly and are lubricated from the oil supply in the differential housing. Bearings are tapered rollers, adjustable to compensate wear. Maintain differential oil level with general purpose gear lubricant (refer to "Lubrication Chart and Service Check Points" in Section 24 for proper oil grade selection) to ensure adequate oil supply to wheel bearings at all times.

### 12.2 Bearing Adjustment

To adjust drive wheel bearings, raise vehicle until both dual wheels can be turned freely (approximately 6 inches from the ground). Position jack stands under drive axle, then lower vehicle approximately 2 inches in order to avoid entire weight of the axle being supported by the suspension air bellows and the shock absorber pins.

Remove axle shaft as indicated in "Rockwell Field Maintenance Manual No. 5" entitled "Single Reduction Differential Carriers" annexed to the end of Section 11 in this maintenance manual. Remove gaskets. Unscrew lock nut and remove adjusting nut lock ring.

To adjust, tighten adjusting nut until the wheel binds, rotate the wheel while tightening so that all surfaces are in proper contact. Back off adjusting nut approximately 1/4 to 1/3 turn to assure 0.001 inch to 0.007 inch end play and to ensure that wheel turns freely. Replace lock ring, and adjust nut dowel pin in one of the holes. The ring may be turned over if necessary to allow more accurate adjustment of bearings.

Tighten lock nut and recheck bearing adjustment. Replace the axle shaft using a new gasket.

## Section 13: WHEELS, HUBS & TIRES

---

### 12.3 Disassembly and Repair

Jack vehicle as outlined above under heading "Bearing Adjustment" and remove axle shaft as indicated in "Rockwell Field Maintenance Manual no. 5" entitled "Single Reduction Differential Carriers" annexed to the end of Section 11 in this maintenance manual. Remove wheels and tires.

**Caution:** *Always mark position of the wheel on the axle prior to removal, to replace wheel at the same location, thus avoiding a new wheel balancing.*

Remove lock nut, lock ring and adjusting nut from axle housing to prevent the outer bearing from falling out. Remove outer bearing cone and roller assembly.

Remove screws attaching inner oil seal retainer to hub, and remove inner oil seal assembly. Remove inner bearing cone and roller assembly. Bearing cups can be removed from the hub using a hammer and a long brass drift.

All parts should be thoroughly cleaned. Bearing cone and roller assemblies can be cleaned in a suitable cleaning solvent using a stiff brush to remove old lubricant.

If excessive wear, deterioration, cracking, or pitting are present on the bearing cups, rollers, or cones, the bearings should be replaced. Seals should be replaced each time they are removed from the hub. To install new oil seal, use a suitable adaptor and drive the seal into the retainer bore until it bottoms.

When installing wheel on spindle, center the wheel hub with spindle to avoid damaging the seal with the end of the spindle. Push wheel straight over the spindle until inside diameter of seal press fits on wiper ring. Prefill hub cavity with general purpose gear lubricant (refer to "Lubrication Chart and Service Check Points" in Section 24 for proper oil grade selection). Lubricate outer bearing cone and assemble. Adjust bearing and lock. Assemble axle flange to axle using a new gasket. Apply sealant in stud area. After both wheels have been assembled according to above

procedure, fill the differential to the proper factory recommended level.

**Note:** *During regular inspection, do not forget to check lubricant level in differential. Clean thoroughly or replace vent as required.*

### 13. TIRE MAINTENANCE

The most critical factor in tire maintenance is proper inflation (Fig. 6). No tire is completely impervious to loss of air pressure. To avoid the hazards of underinflation, lost air must be replaced. Improper inflation decreases tire life.

Any underinflated tire builds up excessive heat that may result in sudden tire destruction thus resulting in possible loss of vehicle control. Check inflation pressure on all the tires, including the spare tire, at least once a week before driving when tires are cold. This is especially important in cases where vehicle is operated by more than one driver.

**Warning:** *Failure to maintain correct tire inflation pressure may result in sudden tire destruction, improper vehicle handling, and will cause rapid and irregular tire wear. Therefore, inflation pressures should be checked weekly and always before long distance trips.*

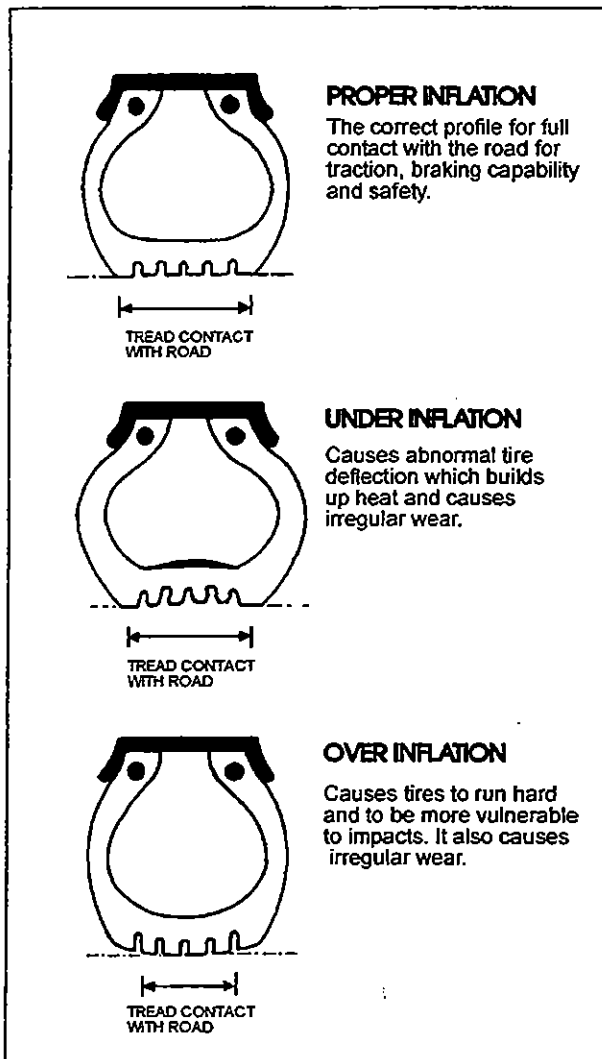

Figure 6: Tire Inflation

MAXE1305

### 13.1 Recommended Tire Inflation Pressure (Cold)

Keep the tires inflated to the recommended inflation pressure for prolonged tire life and safety. If the coach is equipped with 315/80 R 22.5 tires, then see charts below "Standard Inflation Pressure for H3 Coaches", or else see the tire inflation pressures and loadings in the Coach Final Record in the technical publication box provided with the vehicle.

**Note:** For a specific vehicle, inflation pressures vary according to loadings and type of tires.

**Note:** Tires are considered cold when the vehicle has not been driven for at least three hours, or driven less than 1 mile (1,6 km). Driving, even for a short distance, causes tires to heat up and air pressure to increase.

**Note:** Never bleed air from hot tires as tires will then be underinflated. Use an accurate tire gauge to check pressures. (Do not hit tires as an inflation check. This is an unreliable method).

**Note:** In the case of a converted vehicle, weigh vehicle fully loaded and pressurize according to tire manufacturer's recommendations.

**Warning:** All tires on the same axle should always be inflated to the same pressure. There should not be a difference in pressure between right and left tires on the same axle. A 5 psi (35 kPa) underinflation in one front tire can not only destroy ease of steering, but creates steering hazards which can lead to a potential accident.

### 13.2 Tire Matching

Unmatched tires on drive axle will cause tire wear and scuffing, as well as possible damage to the drive unit. Consequently, we recommend that tires be matched within 1/8 inch of the same rolling radius, and 3/4 inch of the same rolling circumference.

**Section 13: WHEELS, HUBS & TIRES**

**13.3 Wheel and Tire Balancing**

Wheels and tires must be clean and free from all foreign matter. The tires should be in good condition and properly mounted. Unbalanced wheel and tire assembly can be due to a bent wheel or improper mounting. Before removing the wheel and tire assembly from the vehicle, check for swaying movement, and if necessary, check the wheel lateral runout as outlined under heading "Wheel Straightness Check". If tire balancing is required, refer to a specialist.

**13.4 Tire Rotation**

The radial tires should be rotated only when necessary. If the tires are wearing evenly, there is no need to rotate. If irregular wear becomes apparent or if the wear rate on the tires is perceptively different (from axle to axle), the tires should be rotated in such a manner as to alleviate the condition.

**Note:** *There is no restriction on criss-cross rotation.*

**Standard Inflation Pressure for H3 Coaches**

H3-41	Tires	Rims	Normal loading			Maximum loading		
			lbs	kg	Tire pressure (psi)	lbs	kg	Tire pressure (psi)
Front	315/80 R 22.5	22.5 X 9	12510	5685	85	16500	7500	115
Diff.	315/80 R 22.5	22.5 X 9	19850	9025	80	21600	9820	85
Tag	315/80 R 22.5	22.5 X 9	11250	5115	75	13700	6225	95
Maximum gross vehicle weight rating: 49,000 lbs (22 270 kg)								

H3-45	Tires	Rims	Normal loading			Maximum loading		
			lbs	kg	Tire pressure (psi)	lbs	kg	Tire pressure (psi)
Front	315/80 R 22.5	22.5 X 9	12725	5785	85	16500	7500	115
Diff.	315/80 R 22.5	22.5 X 9	20900	9500	80	21600	9820	85
Tag	315/80 R 22.5	22.5 X 9	11815	5370	80	13700	6225	95
Maximum gross vehicle weight rating: 49,000 lbs (22 270 kg)								





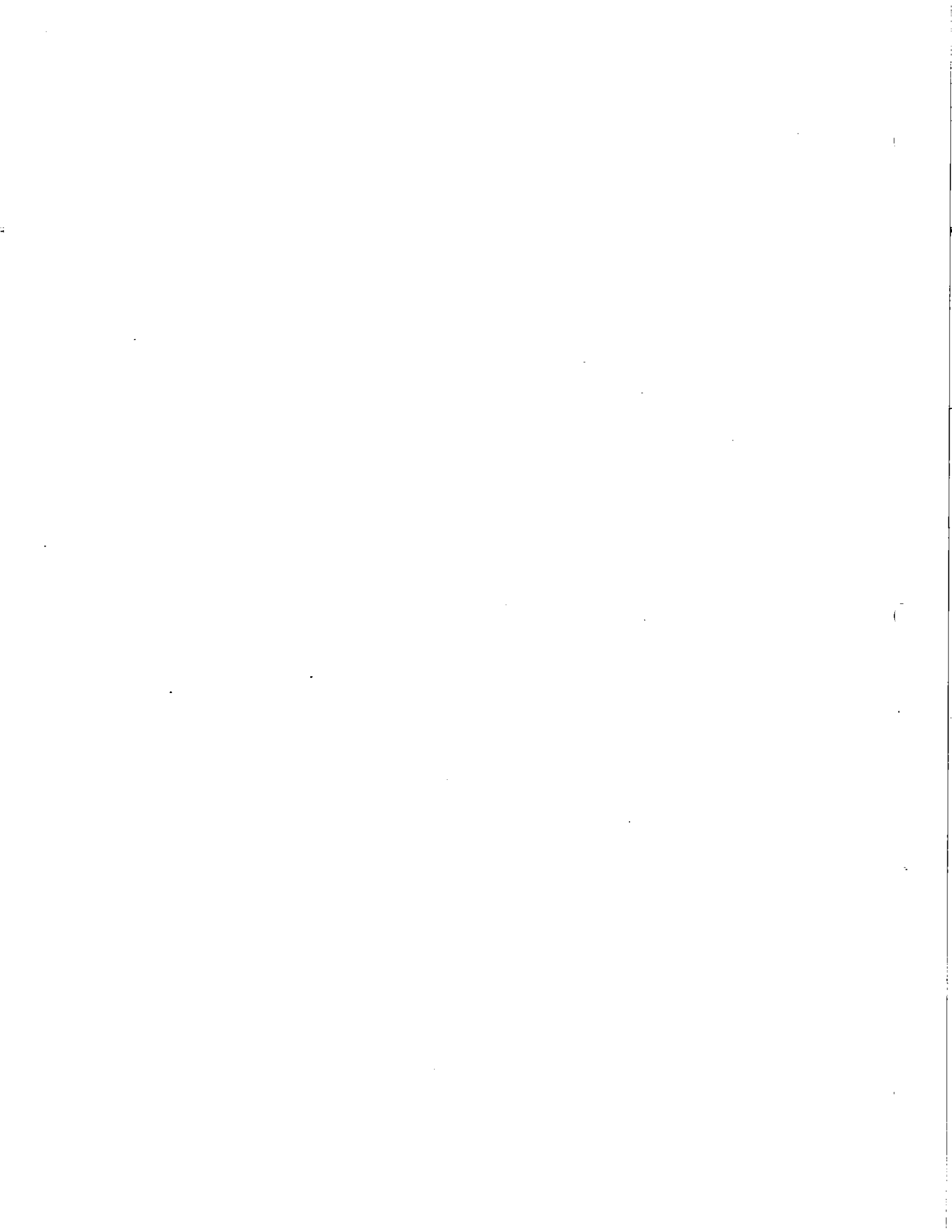

# SECTION 14: STEERING

---

## CONTENTS

1. STEERING SYSTEM.....	2
1.1 Description .....	2
2. POWER STEERING GEAR.....	2
2.1 Description .....	2
3. BLEEDING POWER STEERING HYDRAULIC SYSTEM.....	3
4. HYDRAULIC PRESSURE TEST.....	3
5. TROUBLESHOOTING.....	3
6. POWER STEERING HYDRAULIC PUMP .....	3
6.1 Description .....	3
6.2 Removal and Installation.....	3
7. STEERING WHEEL.....	3
7.1 Removal .....	3
7.2 Installation .....	4
8. STEERING COLUMN.....	4
8.1 Removal and Lubrication .....	4
9. TURNING ANGLE ADJUSTMENT.....	4
10. STEERING LINKAGE ADJUSTMENT .....	4
11. PITMAN ARM.....	4
11.1 Removal .....	4
11.2 Installation.....	5
11.3 Adjustment.....	5
12. MAINTENANCE.....	5
12.1 Power Steering Reservoir and Filter.....	6
12.1.1 Oil Level Check Procedure.....	6
12.1.2 Filter Replacement.....	7
12.2 Steering Stabilizer Cylinder (Damper) .....	7
12.3 Hydraulic Cylinder Assembly .....	7
12.4 Drag Link .....	7
12.5 Power Steering Hydraulic Pump.....	7
13. TORQUE CHARTS.....	8
14. SPECIFICATIONS .....	9

## 1. STEERING SYSTEM

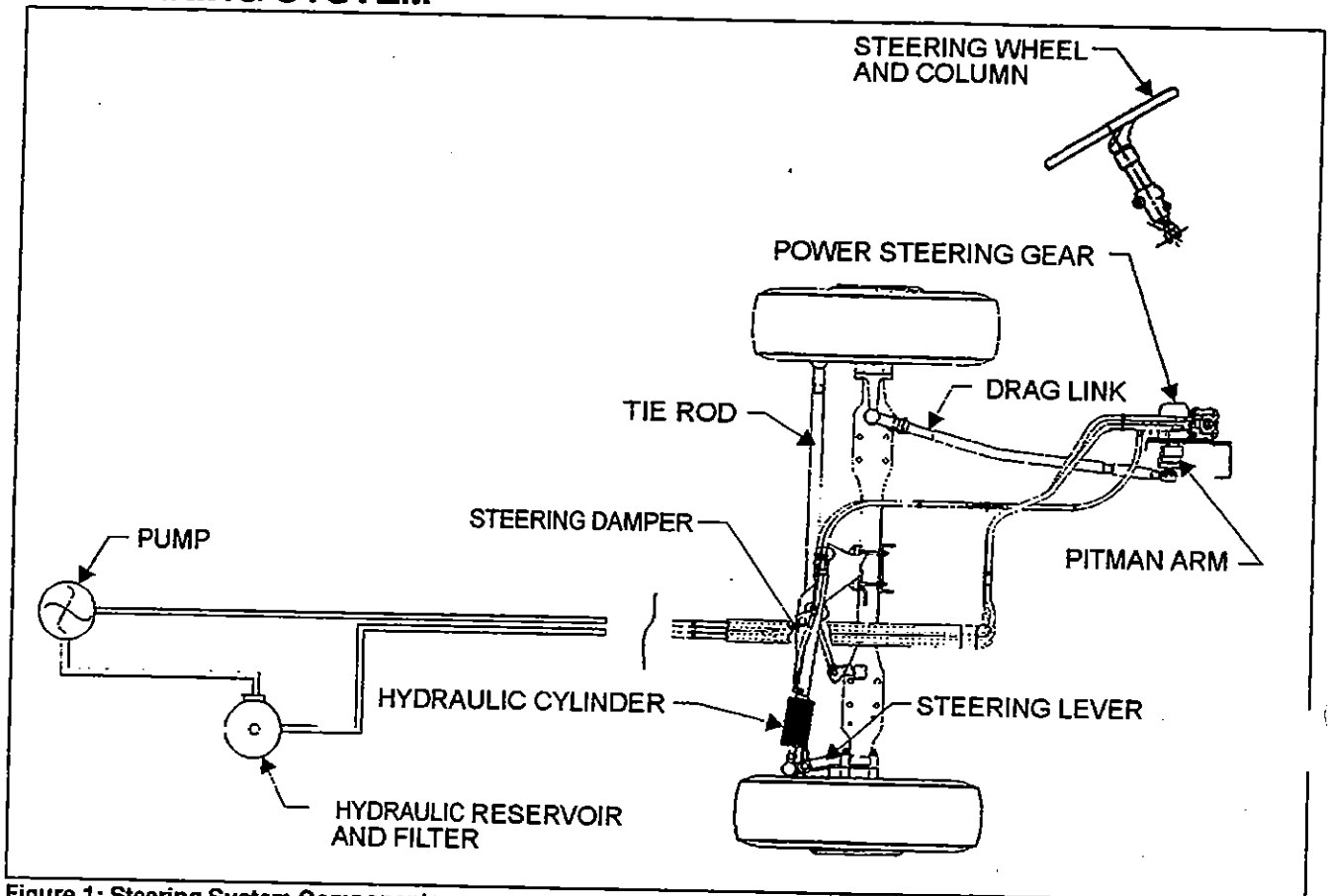

Figure 1: Steering System Components

14004

### 1.1 Description

The steering system is made up of following components, namely the steering wheel, steering column, shaft assembly, power steering gear, tie rod, pitman arm and drag link (Fig. 1).

Hydraulic components are added to transmit, increase and regulate steering control forces. These elements are:

1. Hydraulic cylinder ;
2. Steering stabilizer (damper);
3. A vane type hydraulic pump;and
4. Hydraulic reservoir and hoses.

The steering stabilizer reduces road shocks and vibrations in the system. The steering gearbox is

self powered and provides movement with power assistance mainly to the left wheel. The hydraulic cylinder provides an added source of assistance and, being connected to the right wheel, makes it such that the total steering forces are produced with minimal stress on mechanical linkages.

Wheels, hubs, tires, air suspension, brakes, front suspension and front end alignment are covered in their respective sections in this manual.

## 2. POWER STEERING GEAR

### 2.1 Description

The power steering is located in the front lower service (Fig. 2). The integral power steering gear

(TAS 85) incorporates a manual steering mechanism, a hydraulic control valve and a hydraulic power cylinder.

Refer to the "TAS 85 Steering Gear Service Manual" annexed to this section for the functional aspects and maintenance procedure of the power steering gear.

**Caution:** Before attempting to adjust the poppet valves of the power steering gear, properly set the steering stop screws as outlined in Section 10, "Front Axle", under heading "Turning Angle Adjustment".



Figure 2: Front Service Compartment

14005

### 3. BLEEDING POWER STEERING HYDRAULIC SYSTEM

To bleed the power steering hydraulic system, refer to the "TAS 85 Steering Gear Service Manual" annexed to this section, under heading "Filling and Air Bleeding the System".

### 4. HYDRAULIC PRESSURE TEST

Perform a pressure test as outlined in the "Chart your Way to Easy Steering" annexed to this section.

## 5. TROUBLESHOOTING

Perform troubleshooting of the steering gear as outlined in the "Chart your Way to Easy Steering" annexed to this section.

## 6. POWER STEERING HYDRAULIC PUMP

### 6.1 Description

The power steering pump is a vane type, gear driven, hydraulic unit which supplies hydraulic pressure for the operation of the steering gear. The pump is mounted on the engine, beside the crankshaft pulley.

### 6.2 Removal and Installation

The pump is accessible through the engine compartment rear door. To remove the pump, disconnect the inlet and outlet hoses from the pump, then remove the two mounting screws. Cap hose openings to prevent contamination of hydraulic system. The mounting flange gasket should be replaced whenever pump is removed. To install pump, reverse the removal procedure.

## 7. STEERING WHEEL

### 7.1 Removal

1. Set the battery main disconnect switches to the "Off" position.
2. Using a tool, such as a little flat head screwdriver, pry off the electric horn cap.
3. Loosen the small screw in center of cap and the other retaining the black wire, then disconnect the white terminal. Remove horn cap.
4. Loosen and remove the steering wheel nut.
5. Using a suitable puller, remove the steering wheel.

## Section 14: STEERING

### 7.2 Installation

To install, reverse the removal procedure. Torque steering wheel nut to 35-45 lbf·ft (47-60 N·m).

## 8. STEERING COLUMN

### 8.1 Removal and Lubrication

To disassemble the steering column, refer to Figure 4 as a guide. The steering column has three lubrication points which must be serviced only when needed, using a good quality lithium-base grease NLGI No. 1 and 2. The lower steering column U-joint grease fitting is easily accessible through the front service compartment. The upper steering column U-joint and the steering slip joint grease fittings are accessible from the front driver's area. To access these fittings, proceed as follows:

1. From the front driver's area, unfasten and lift the steering column boot, then remove the four snap caps on front of upper steering column cover (refer to Fig. 3).
2. Unscrew the four retaining screws on upper steering column cover. Remove the upper cover.
3. Unscrew the three retaining screws on lower steering column cover. Remove the lower cover.
4. Position the steering wheel in order to gain access to the grease fittings.

**Note:** For an easier access to the slip joint grease fitting, lift steering wheel to its maximum position using the release handle located on the left-hand side of the steering column.

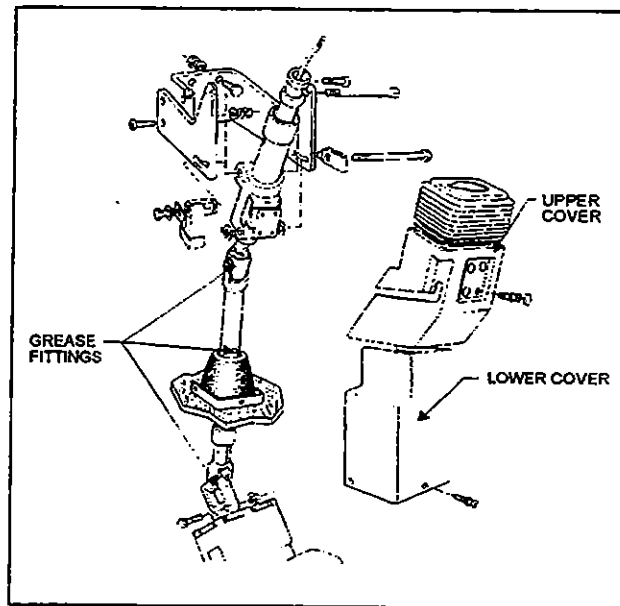

Figure 3: Steering Column

14008

## 9. TURNING ANGLE ADJUSTMENT

To adjust the turning angle, refer to Section 10, "Front Axle", under heading "Turning Angle Adjustment".

## 10. STEERING LINKAGE ADJUSTMENT

To adjust the steering linkage, refer to Section 10, "Front Axle", under heading "Front End Alignment".

## 11. PITMAN ARM

### 11.1 Removal

1. Remove cotter pin, nut and washers from drag link ball stud at pitman arm.
2. Disconnect drag link from pitman arm, using jaw style pullers (pressure screw type).

**Warning:** Always wear approved eye protection when operating pullers.

**Caution:** Do not drive pitman arm on or off pitman shaft as this can damage the steering gear.

**Caution:** Heating of components to aid in disassembly is not allowed because it has a detrimental effect on axle components and steering linkages.

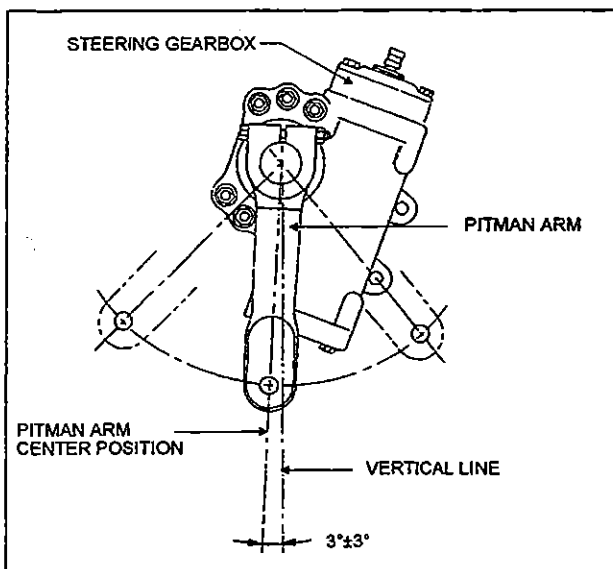

Figure 4: Pitman Arm Adjustment

14007

3. Remove pitman arm clamp bolt nut, washer and bolt.
4. Check the radial position of the pitman arm in relation to the sector shaft prior to removal of pitman arm.
5. Add reference marks to the arm and shaft if necessary to ensure correct alignment at reassembly.
6. Remove pitman arm. A chisel will help you loosen the pitman arm. Use a puller if you cannot remove the pitman arm manually.

## 11.2 Installation

1. Position pitman arm on sector gear shaft with reference marks aligned. Ensure that the clamp bolt groove matches.
2. Install bolt, washer and nut. Tighten nut to 280-300 lbf•ft (380-408 N•m).
3. Connect drag link to pitman arm. Install washers. Tighten nut to 200-220 lbf•ft (272-300 N•m). Afterwards, install a new cotter pin.

## 11.3 Adjustment

1. Disconnect the drag link from pitman arm. Center steering wheel by dividing the total number of steering wheel turns in two. Scribe a reference mark on steering gearbox at the center previously determined.
2. Using a protractor, check the angle of the pitman arm (refer to Fig. 4 for details).
3. The pitman arm should be adjusted to an angle of  $3^\circ \pm 3^\circ$  in relation with the vertical axis (towards rear of vehicle). If not, unscrew and remove bolt, nut and washer. Remove the pitman arm according to the procedure outlined under previous heading "Pitman arm removal". Adjust to the proper angle.
4. When adjustment is achieved, replace bolt, nut and washer, and torque to 280-300 lbf•ft (380-408 N•m).

## 12. MAINTENANCE

The power steering system requires little maintenance. However, the system should be kept clean to ensure maximum operating performance and troublefree service. Periodic inspections should also be made to check leakage.

## Section 14: STEERING

---

When the slightest evidence of dirt, sludge or water is discovered in the system, disconnect fluid lines at the power steering gear to drain the system. Drain and refill the system with "Dexron-II E or Dexron-III" automatic transmission oil.

Air in the hydraulic system will cause spongy action and noisy operation. When any hose has been disconnected or when fluid has been lost for any reason, the system must be bled. Bleed system as outlined under heading "Bleeding Power Steering Hydraulic System" later in this section.

**Warning:** Do not operate the pump without fluid in the power steering fluid reservoir.

If the steering linkage between the steering gear and the two front wheels is not properly adjusted, bent, twisted or worn, the steering of the vehicle will be seriously impaired. Whenever any steering linkage part is repaired, replaced or adjusted, steering geometry and front wheel alignment must be checked and necessary corrections made. Refer to Section 10, entitled "Front Axle" for Front End Alignment.

At regular lubrication intervals, the steering linkage should be thoroughly inspected for worn or loose components.

After the vehicle has been operated continually and high mileage figures have been reached, overhaul of the various steering units will be required. General overhaul procedure normally requires removal of the entire assembly, cleaning and inspection of all parts and final assembly. Careful inspection of all parts during overhaul is very important and must not be neglected.

All lubrication fittings must be cleaned before applying lubricant. Moreover, always be sure the equipment used in applying lubricant is clean. Every precaution should be taken to prevent entry of dirt, grit, lint or other foreign matter into lubricant containers. Replace fittings that have become broken or damaged. Lubrication intervals, as well as the recommended lubricants for the steering components, are given in the "Lubrication and

Service Schedule" in Section 24 of this manual. The intervals given in the schedule are recommended for normal service. More frequent intervals may be required under severe operating conditions.

## 12.1 Power Steering Reservoir and Filter

The power steering reservoir is located on R.H. side of engine compartment, on front wall (Fig. 5).

At regular intervals, fluid level should be checked in the reservoir and filter assembly. Furthermore, the oil filter cartridge element in the power steering reservoir should be replaced every 50,000 miles (80 000 km) or once a year, whichever comes first.

### 12.1.1 Oil Level Check Procedure

1. Stop engine. Open engine compartment R.H. side door.
2. Unscrew and remove the dipstick located on top of reservoir and wipe with a clean rag.
3. Replace dipstick in reservoir. Remove it again to check fluid level.
4. Adjust level to "FULL" mark, using "Dexron-II E or Dexron-III" automatic transmission oil.
5. Replace and tighten the dipstick.



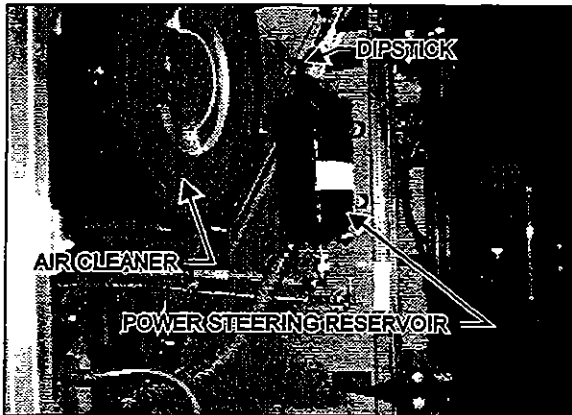

Figure 5: Engine Compartment R.H. side Door 14006

### 12.1.2 Filter Replacement

1. Unscrew and remove the wing nut located on top of the power steering reservoir.
2. Remove the reservoir cover and gasket.
3. Remove the retaining spring and finally the filter cartridge element.

## 12.2 Steering Stabilizer Cylinder (Damper)

This vehicle is provided with a steering stabilizer cylinder installed on right-hand side of front axle. The cylinder is non-repairable, so if oil leakage is evident or cylinder has no resistance, the complete unit must be replaced. Lubricate the steering stabilizer cylinder rod end every 6,250 miles (10 000 km) or twice a year, whichever comes first. Good quality lithium-base grease NLGI No. 1 and 2 are recommended. Inspect the spherical joint regularly. In case of wear, replace rod end assembly.

## 12.3 Hydraulic Cylinder Assembly

The hydraulic cylinder is installed on the right hand side of front axle. Repair kit number 66-0902 containing seal is available. Lubricate the fittings

at each cylinder end of the power steering cylinder every 6,250 miles (10 000 km) or twice a year, whichever comes first. Good quality lithium-base grease NLGI No. 1 and 2 are recommended

## 12.4 Drag Link

Lubricate the fittings every 6,250 miles (10 000 km) or twice a year, whichever comes first. Good quality lithium-base grease NLGI No. 1 and 2 are recommended.

## 12.5 Power Steering Hydraulic Pump

For the maintenance of the power steering hydraulic pump, refer to the "Vickers Overhaul Manual" annexed to this section.

**Section 14: STEERING**

**13. TORQUE CHARTS**

TORQUE (DRY)			
Descriptions	References	lbf·ft	N·m
Drag link end stud nut (on steering arm)	Fig. 1	160-300	218-409
Drag link end pinch bolt nuts	Fig. 1	50-65	68-88
Drag link end stud nut (on pitman arm)	Fig. 1	160-300	218-409
Tie rod end screw pin nut	Fig. 6, T1	100-175	136-237
Tie rod end pinch bolt nuts	Fig. 6, T2	65-75	88-102
Hydraulic cylinder fixation nuts	Fig. 6, T1	160-300	218-409
Steering stabilizer cylinder fixation nuts	Fig. 7, T2	100-120	136-164
Retaining rod support fixation nuts	Fig. 7, T3	150-200	204-273
Steering damper and hydraulic cylinder mounting support nuts	Fig. 7, T4	66-70	90-95
Steering top lever nuts	Fig. 7, T5	150-200	203-271

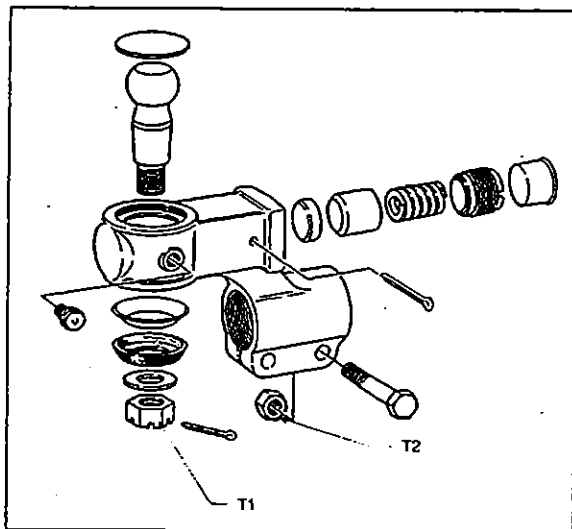

**Figure 6: Tie Rod End**

14009

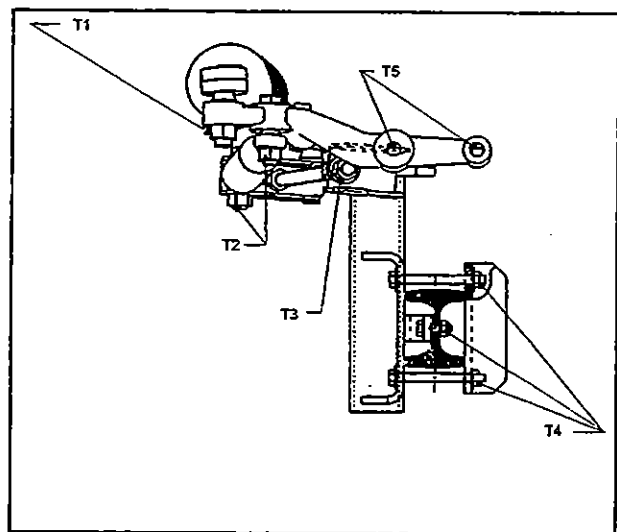

**Figure 7: Front Axle Components**

14010

Section 14: STEERING

14. SPECIFICATIONS

Power Steering Gear

Make ..... TWR  
Model ..... TAS 85  
Supplier number ..... TAS85040  
Prevost number ..... 66-0927  
F.E.W ..... 18,000 lbs (8 200 kg)  
Pressure rating ..... 2,175 psi (150 Bar)  
Gear ratio ..... 23.3:1  
Minimum pump flow for 1.5 hwt/sec ..... 3.5 gpm (13.2 lpm)

Power Steering Pump

Make ..... Vickers  
Type ..... V20  
Relief valve setting ..... 2,000 psi (13 790 kPa)  
Capacity ..... 11 GPM/1200 RPM  
Inlet port ..... 1 1/4 NPT  
Outlet port ..... 3/4-16 straight thread SAE o-ring boss conn.  
Supplier number ..... V20NF-1P11T-38C6H22LH  
Prevost number ..... 66-0933  
Gasket - Supplier number ..... 23516100  
Gasket - Prevost number ..... 51-0488

Power Steering Reservoir

Make ..... Nelson Muffler  
Oil capacity ..... 4 US qts (3.7 liters)  
Supplier number ..... 91410A  
Prevost number ..... 66-0982  
Make ..... Nelson Muffler  
Element filter - Supplier number ..... 83804 E  
Element filter - Prevost number ..... 66-0987

Steering Stabilizer Cylinder (Damper)

Make ..... Gabriel  
Extended length ..... 32.73±0.12"  
Collapsed length ..... 20.26±0.12"  
Stroke ..... 12.47±0.12"  
Supplier number ..... 651535  
Prevost number ..... 66-0979  
Dust cap - Prevost number ..... 66-0980

Hydraulic Cylinder Assembly

Make ..... Hayes-Dana  
Bore ..... 1 1/2"  
Stroke ..... 17"  
Rod diameter ..... 0.875"  
Supplier number ..... 006-9231-0  
Prevost number ..... 16-0886  
Repair kit - Supplier number ..... 306-7200-00  
Repair kit - Prevost number ..... 66-0902

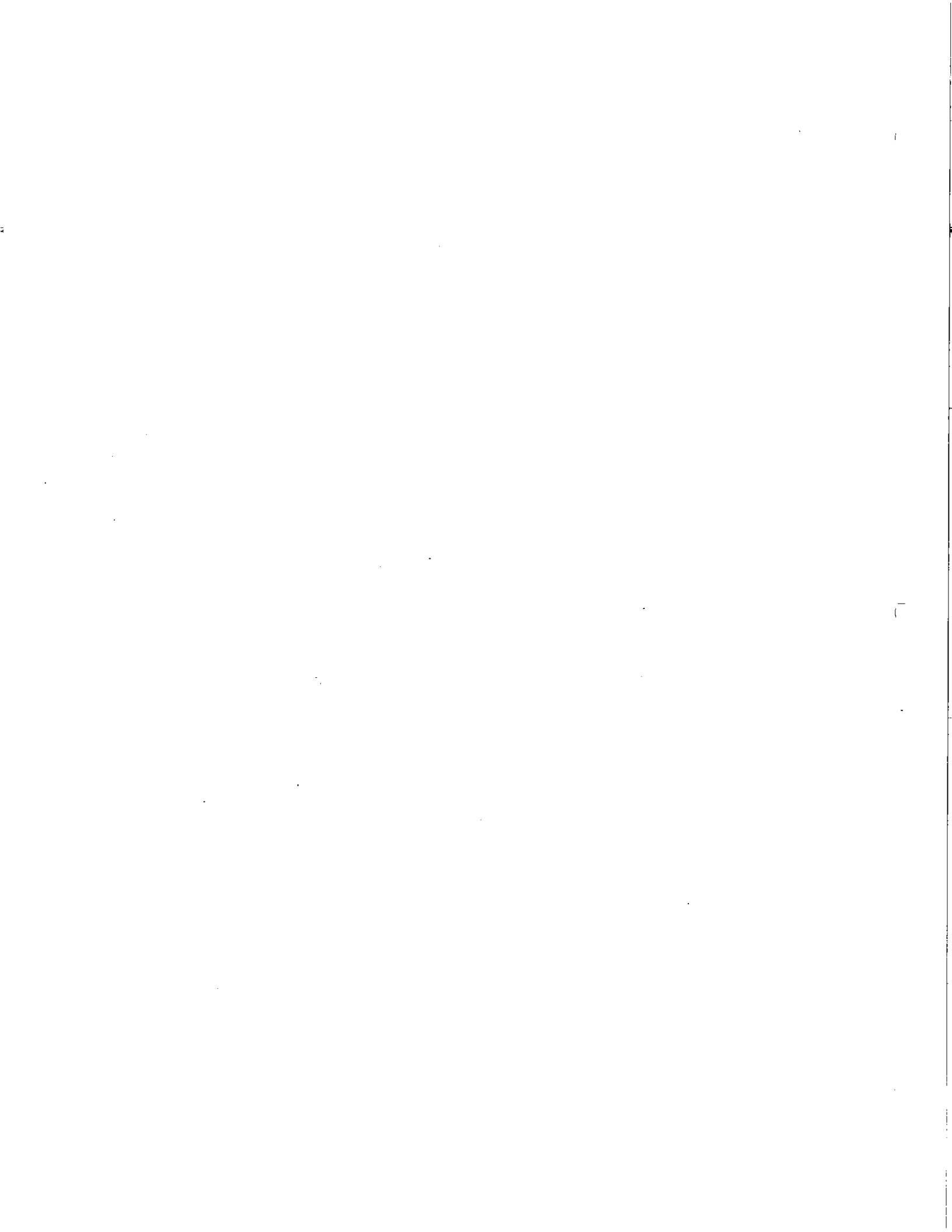



## MAINTENANCE INFORMATION

### MI13-16

DATE :	MARCH 2013	SECTION :	14 - Steering
SUBJECT :	DRAGLINK TURNBUCKLE CLAMPS ORIENTATION - ALL MODELS		

### ***IMPORTANT NOTICE***

*This Maintenance Information supersedes the info contained in your maintenance manual. This modification is recommended by PrevoSt to increase your vehicle's performance. Note that no reimbursement will be awarded for carrying out this modification.*

### **APPLICATION**

<b>Model</b>
All models with I-beam front axle and turnbuckle draglink. Model Year : 1994 up to 2013

### **DESCRIPTION**

This Maintenance Information supersedes the info contained in your maintenance manual. Add this bulletin to the steering section of the pertaining maintenance manuals.

On all models starting with model year 1994, particular attention must be awarded to draglink turnbuckle clamp orientation at part removal and replacement.

Proper clamp position is shown here and should be maintained at all times.

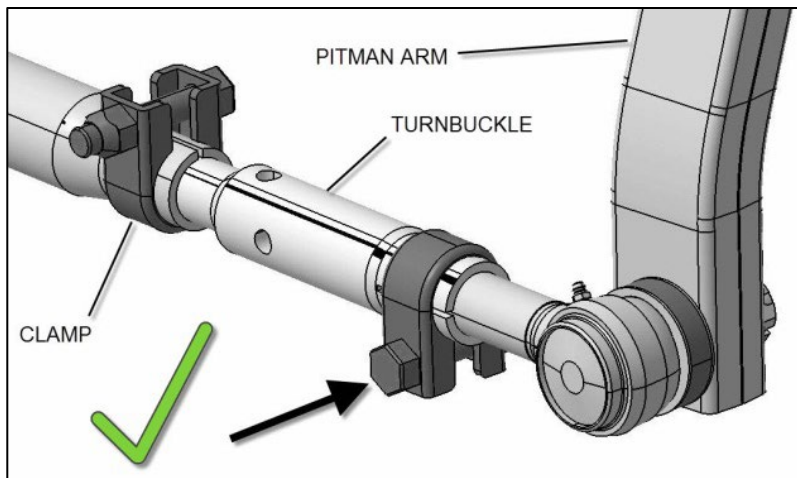

*Note horizontal orientation of clamp bolt and bolt insertion direction.  
Prescribed torque for clamp bolt (arrow) is between 50 and 60 lbf-ft. Applies to both clamps.*

If replacement is required, order the following parts:

Part No.	Description	Qty
160932	Turnbuckle	1
661133	Clamp	2

**NOTE**

Material can be obtained through regular channels.

## PROCEDURE

The scope of this procedure is to inspect the steering draglink turnbuckle clamp orientation on vehicles with an I-beam front axle.

If required the procedure details how to perform the replacement of the turnbuckle and clamps without undergoing a vehicle alignment.



### DANGER

Park vehicle safely, apply parking brake, stop engine and set battery master switch(es) to the OFF position prior to working on the vehicle.

#### 1. Setting-up for the procedure

Drive the vehicle in the service bay, making sure to leave the steering wheel as straight as possible.

Mark steering wheel position with a pair of masking tape. Align the tapes by placing one piece on the dashboard and the other on the steering wheel.

This will be your reference to restore the steering to its original state if any part replacement is required.

Note that on vehicles having a substantial steering wheel indexation or offset, the vehicle wheels may not be straight ahead when starting procedure. This does not affect the procedure in itself.

Leave vehicle on the ground to make sure the wheels will not move.



Recline the front bumper and remove spare tire.

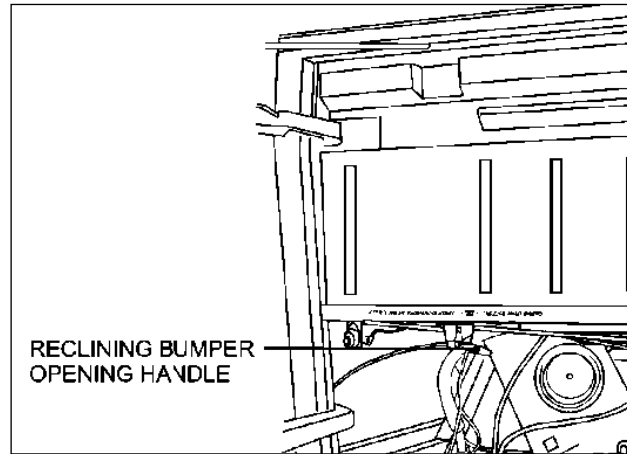

Locate the steering gear pitman arm on the driver's side of the spare tire compartment.



## 2. Steering operation inspection

Turn wheels all the way left.

No contact should occur between pitman arm and bolt.

If contact occurs, replace both clamps and turnbuckle.

Refer to Catbase parts manual to select appropriate parts for your vehicle.

Follow replacement procedure below.



### 3. Pitman arm and bolt shank inspection

If no contact occurs in the above inspection, visually inspect the fore clamp bolt shank and pitman arm surface for previous contact marks.

Typical signs of contact may be a circular rust spot (1) on the pitman arm and/or flattened threads on bolt shank end (2).

If any one of these contact marks is visible, replace clamps and turnbuckle following procedure below.

If there is no contact evidence, proceed to clamp inspection.

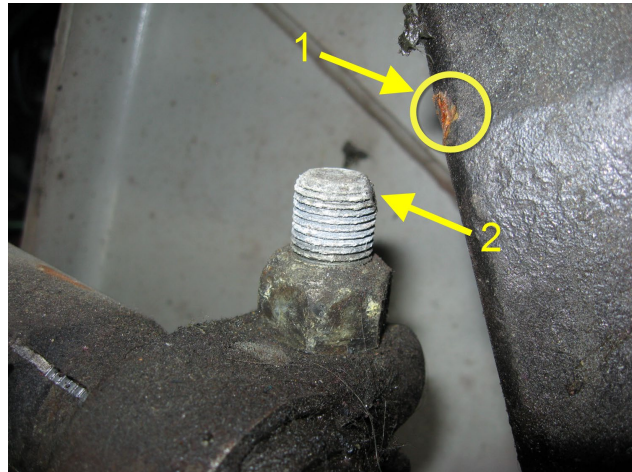

### 4. Clamp inspection

Proper draglink clamp orientation is shown here.

*Note horizontal orientation of clamp bolt and bolt insertion direction.*

Clamps should not be bent or squeezed by the bolt. If this is the case, they have been over torqued and should be replaced. Refer to replacement procedure below.

If clamps are in good condition but are not properly oriented, rotate the clamps as shown.

If clamps are properly oriented and in good condition, proceed to interference inspection.

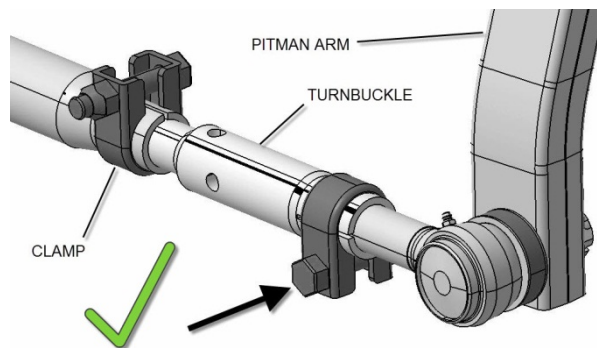

*Clamp is bent. Replace clamp.*



## 5. Turnbuckle replacement procedure

Apply this procedure to change the turnbuckle without undergoing a vehicle alignment.

Mark center of ball joint.

Measure distance **(A)** between center of ball joint on pitman arm and draglink end.

**A** : \_\_\_\_\_

Unfasten clamps.

Release the clamps.

Rotate turnbuckle by inserting a tool like a round nose chisel in the turnbuckle holes.

Install the new clamps on the new turnbuckle. Make sure bolts are inserted as shown on the clamps.

Apply a small amount of anti-seize compound to the turnbuckle threads.

Engage the turnbuckle female threads two or three turns on the ball joint end.

➤ **Two people are required for next steps.**

Align turnbuckle and draglink. Have a partner turn the steering wheel to position the turnbuckle male threads ready to engage in the draglink.

Engage by turning the turnbuckle in the draglink while applying a light tension on the steering wheel to help thread insertion.

Adjust the turnbuckle until you reach measure **(A)** noted earlier.

At this point, make sure threads are visible the entire length of the slots on the draglink and turnbuckle female ends.

Finish by making fine adjustments to align the tape marks on the steering wheel.

This will return the steering to its original state.

Make sure the ball joints at each end of the draglink assembly are in neutral

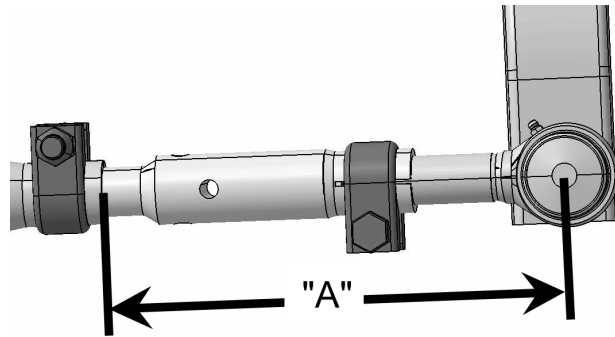

THREADS MUST BE VISIBLE  
THE ENTIRE LENGTH OF THE SLOT

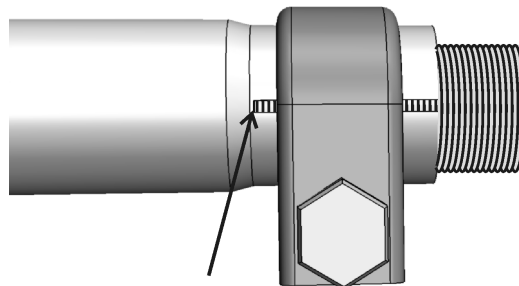

position (centered) before final clamp tightening.

Clamp bolts should be installed horizontal with bolt head as shown. Tighten clamp bolts to 50-60 lbf-ft.

Mark bolt head with torque seal.

Remove rust and restore the paint finish on the pitman arm to mask any contact marks. This way any future contact will be revealed.

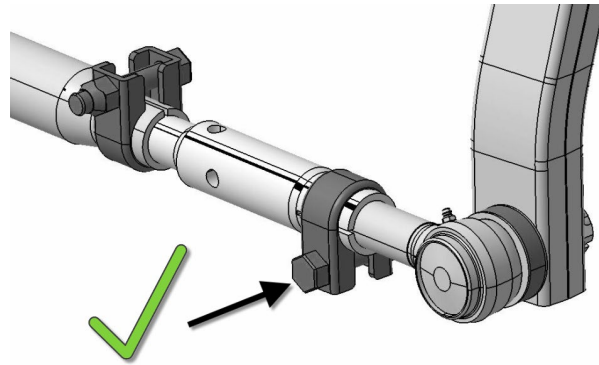

## 6. Interference inspection

➤ **Two people are required for next steps.**

Turn the wheels fully in both directions while another person inspects the linkage for interference with surrounding structural parts and components.

Minimum acceptable clearance is 3/8".

### Waste disposal:

Discard according to applicable environmental regulations (Municipal/State[Prov.]/ Federal)

Access all our Service Bulletins on  
<http://prevostparts.volvo.com/technicalpublicatios/en/pub.asp>  
 Or scan the QR-Code with your smart phone.

E-mail us at [technicalpublications\\_prev@volvo.com](mailto:technicalpublications_prev@volvo.com) and type "ADD" in the subject to receive our warranty bulletins by e-mail.





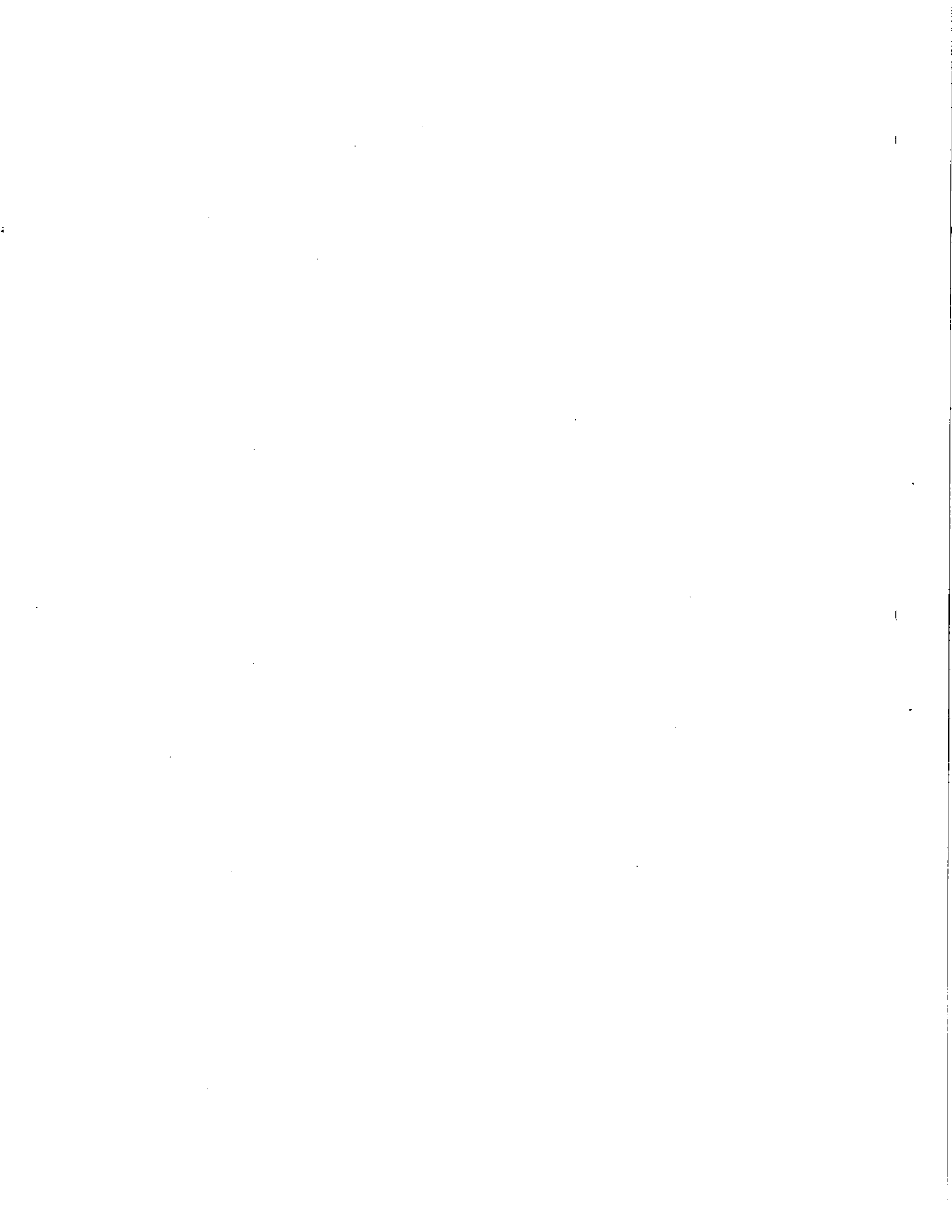

# SECTION 16: SUSPENSION

## CONTENTS

1. DESCRIPTION.....	3
2. AIR SPRING.....	4
2.1 Inspection.....	5
2.2 Removal.....	5
2.3 Installation.....	5
3. SHOCK ABSORBER.....	5
3.1 Inspection.....	6
3.2 Removal.....	6
3.3 Installation.....	7
4. RADIUS ROD.....	7
4.1 Inspection.....	7
4.2 Removal.....	7
4.3 Bushing Removal.....	7
4.4 Bushing Installation.....	8
4.5 Installation.....	8
5. SWAY BAR.....	9
5.1 Removal.....	9
5.2 Installation.....	9
6. SUSPENSION AIR SYSTEM.....	10
6.1 Description.....	10
6.2 Inspection.....	10
6.3 Air Line Test.....	10
6.4 Air Tank Maintenance.....	10
7. SUSPENSION HEIGHT ADJUSTMENT.....	10
8. HEIGHT CONTROL VALVE.....	11
8.1 Operation.....	11
8.1.1 Loading Position.....	11
8.1.2 Neutral Position.....	11
8.1.3 Unloading Position.....	11
8.2 Maintenance.....	11
8.2.1 Removal and Installation.....	12
8.2.2 Air Leakage Test.....	12
9. FRONT KNEELING AND HI-BUOY SYSTEM.....	12
9.1 Principles of Operation.....	13
9.2 Maintenance.....	13
9.3 Bellows Control and Exhaust Solenoid Valves.....	13
9.3.1 Removal and Installation.....	13
10. HI-BUOY SYSTEM.....	14
10.1 Principles of Operation.....	14
11. LOW-BUOY SYSTEM.....	14
11.1 Principles of Operation.....	14

**Section 16: SUSPENSION**

---

12. "LEVEL-LOW" LEVELING SYSTEM .....	14
12.1 Principles of Operation.....	15
13. TROUBLESHOOTING .....	16
14. PARTS SPECIFICATIONS .....	16
15. TORQUE SPECIFICATIONS.....	17

# 1. DESCRIPTION

The vehicle is provided with an air suspension system. The system consists of air springs, height control valves, radius rods, sway bars and shock absorbers. The system operation is fully automatic

and maintains a constant vehicle height regardless of load, or load distribution.

The vehicle can also be equipped with systems such as *Front kneeling & hi-buoy*, *Low-buoy*, *Hi-buoy*, and/or *Level-low*. For a description of all these systems, refer to the appropriate heading in this section.

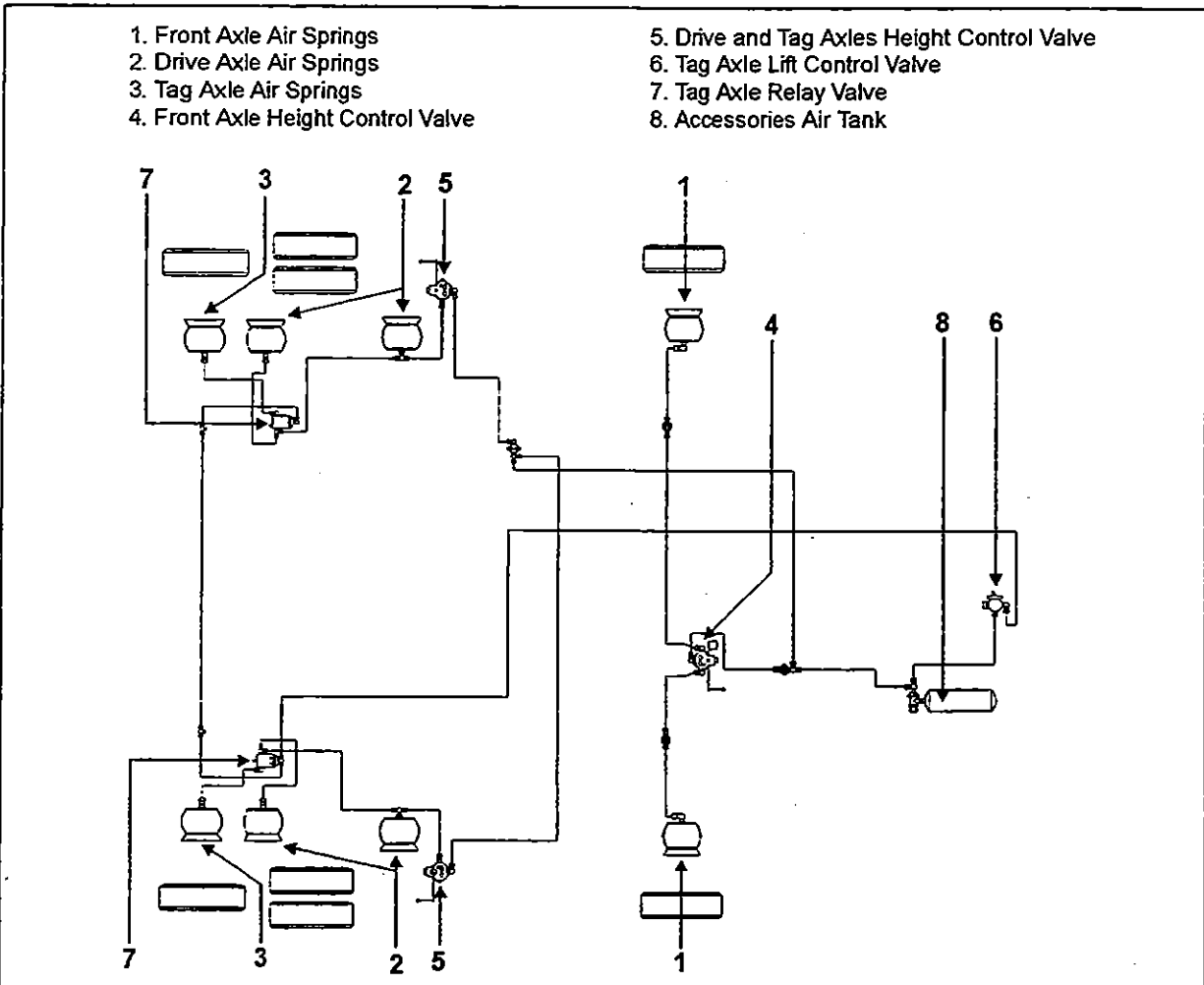
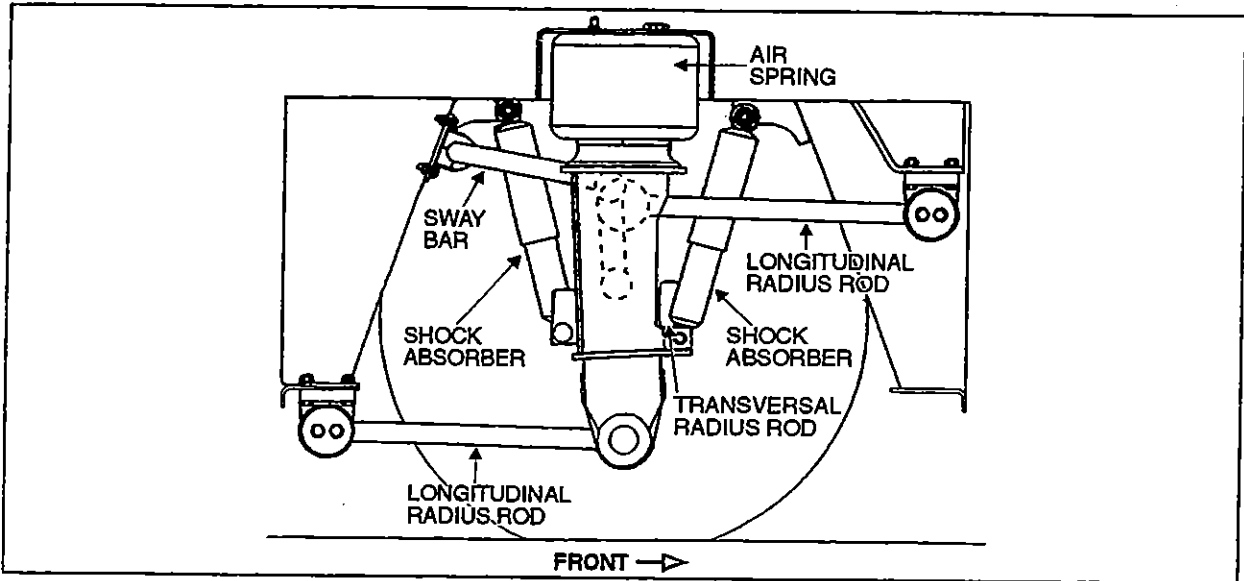

Figure 1: Pneumatic Suspension Components

16006

**Section 16: SUSPENSION**



**Figure 2: Front Suspension Components**

16002

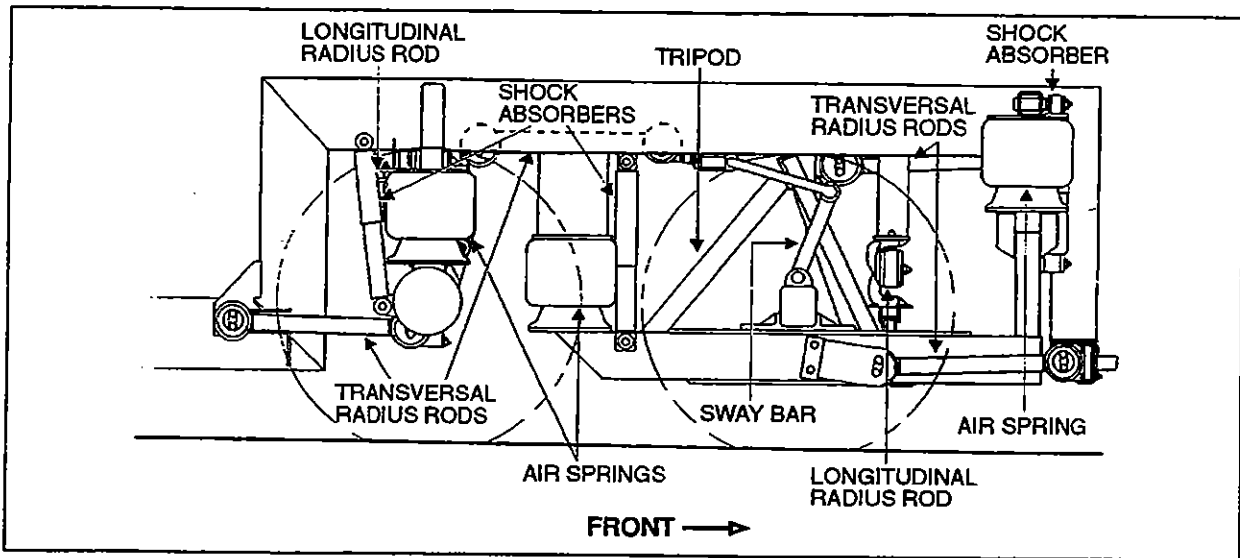
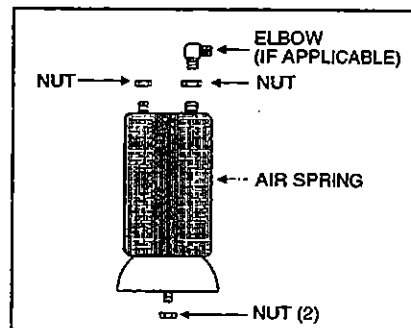

**Figure 3: Rear Suspension Components**

16003

**2. AIR SPRING**

The "rolling lobe" type air springs are made from a special compound rubber molded to the proper contour and dimensions. The entire vertical load of the vehicle is supported by these springs. Each of the three axles is provided with air springs that are attached to the subframe and to the axles.



**Figure 4**

16007



## 2.1 Inspection

1. Check operation of bellows.
2. Visually inspect bellows for evidence of cracks, punctures, deterioration, or chafing. Replace the bellows if any damage is evident.
3. With the primary air system at normal operating pressure (95 - 125 psi (655 - 860 kPa)), coat all suspension air line connections and bellows mounting areas with a water and soap solution. Bubbles will indicate an air leak, and none is permissible. Repair or replace defective parts.

**Note:** If air spring is removed from vehicle, bellows can be lightly inflated and submerged in water to detect any leakage. If any leakage is detected, replace bellows.

**Warning:** To prevent personal injury, do not apply more than 10 psi (69 kPa) air pressure with the air spring unmounted.

## 2.2 Removal

**Note:** Suspension air springs (front, drive, and tag axles) can be removed without removing the entire axle assembly.

1. Safely support vehicle at the recommended body jacking points.

To gain access to a given air spring, the corresponding wheel can be removed as follows:

- a) Jack vehicle until the tire clears the ground, and place safety supports underneath body.

**Caution:** Only the recommended jacking points must be used as outlined in Section 18, "Body".

- b) Support the axle with a suitable hydraulic floor jack at the recommended jacking point.
  - c) Remove wheel.
2. Exhaust compressed air from accessory air tank by opening drain cock under reservoir.
  3. Disconnect the height control valve link and pull down the overtravel lever to ensure all air is exhausted from air springs.

**Note:** While performing this step, do not change the height control valve overtravel lever adjustment.

4. Disconnect air line from air spring, remove elbow (if applicable), and cover both the line end and fitting to prevent the entry of foreign matter.
5. Remove the two air springs upper nuts, and then the two lower nuts. Remove air spring.

## 2.3 Installation

1. Compress air spring as necessary, then aligning studs with their holes, position air spring between both the lower and upper supports. Thread the lower nuts and the small upper nut a few turns.
2. Tighten and torque the lower stud nuts, and then the upper one to 20 - 25 lbf-ft (27 - 34 N·m).
3. Thread the remaining upper nut (large nut) and tighten to 20 - 25 lbf-ft (27 - 34 N·m).
4. Install elbow (if applicable), then connect air line.
5. Connect the height control valve link.
6. Build up air pressure in system.

**Note:** To accelerate this operation, air reservoirs can be filled from an exterior air supply connected to the accessory tank fill valve or to the emergency fill valve.

7. Check operation of bellows, and with the primary air system at normal operating pressure (95 - 125 psi (655 - 860 kPa)), coat the air line connections and air spring mounting areas with a water and soap solution. Bubbles will indicate an air leak, and none is permissible. Repair or replace defective parts.
8. Remove the hydraulic floor jack from under the axle, then lower vehicle to ground.

## 3. SHOCK ABSORBER

Double-action, telescoping-type shock absorbers ensure a smooth ride and enhance vehicle stability on the road. All shock absorbers are eye-type mountings. The front and tag axles are each pro-

## Section 16: SUSPENSION

vided with two shock absorbers while the drive axle is provided with four of them.

Shock absorbers are non-adjustable and non-repairable. Maintenance requirements involve replacement of the rubber mounting bushings, and tightening of all shock absorber pins at the proper torque (350 - 400 lbf-ft (475 - 545 N·m)) when shock absorber replacement occurs. If a shock absorber becomes inoperative, complete unit must be replaced.

**Caution:** When a shock absorber is found defective, always replace with a new set on affected axle, except if there has been a recent replacement of one unit. The following method will help in determining if both shock absorbers on the same axle have to be replaced.

### 3.1 Inspection

Loosen lower mounting of both shocks, then carefully attempt to raise and lower the bottom portion of each shock. Note the rate of effort for distance of travel. Replace both shocks if a definite differential rate is found.

The shock must be bench checked in an upright, vertical position. If checked in any other position, air will enter the cylinder tube and make the shock absorber appear defective.

Proceed as follows to check shock absorbers:

1. With the shock absorber in a vertical position (top end up), clamp the bottom mount in a vise.

**Caution:** Do not clamp the reservoir tube or the dust tube.

2. Rotate the dust tube. Notice any binding condition (may be compared with new unit). Binding condition indicates a scored rod. Units with scored rods should be replaced.
3. Fully extend shocks and check for leaks in the seal cover area. Shock fluid is a very thin hydraulic fluid that has a characteristic odor and dark brown tint. A slight trace of shock fluid around the seal cover area is not a cause for replacement. The shock seal is designed to permit a very slight seepage to lubricate the rod. Units which leak should be replaced.

4. Visually check shock for dents that could cause the shock to bind. Also, check for a bent rod.
5. Extend and collapse shock to determine that it has control (resistance) in both rebound and compression.
6. Visually inspect the shock mountings and vehicle mountings for:
  - a) Broken mounts;
  - b) Extreme bushing wear;
  - c) Shifted bushing or sleeve;
  - d) Deep cracks in bushing material (shallow surface cracks are normal);
  - e) Loose shock absorber pins;
  - f) Presence of convex washers, and position of them according to the rubber bushing.

### 3.2 Removal

1. Remove nuts and washers from shock absorbers on upper and lower mounting pins, taking care to identify the inner and outer washers to ease reinstallation. Refer to figure 5 for details.

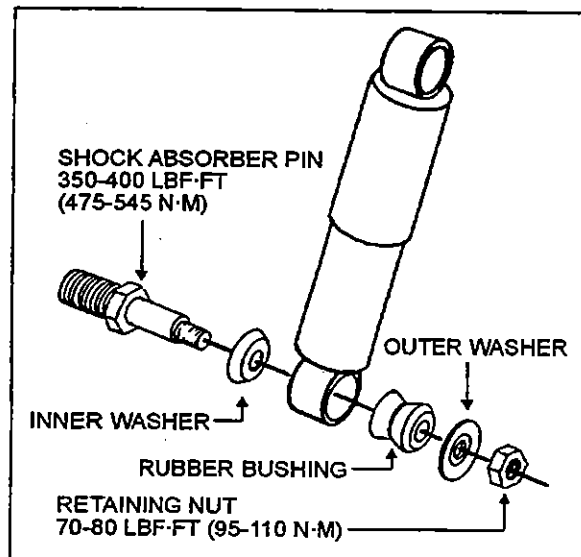

Figure 5

16008

2. Remove the shock absorber assembly from pins.

- Remove the two inner bushings from the shock absorber, and discard them.

### 3.3 Installation

- Ensure that the shock absorber mounting pins are tight and that the threads are not stripped.
- Install new rubber mounting bushings on shock absorbers (upper and lower).
- Place the inner washers (with washer convex side facing the shock absorber rubber bushing) on each shock absorber pin (see fig. 6).

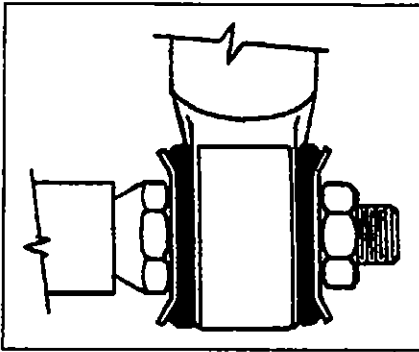

Figure 6

16009

- Install the shock absorber eyes over the mounting pins, then the outer washers (with washer convex side facing the shock absorber rubber bushing) on each shock extremity.
- Place the lower and upper mounting pin stud nuts and torque them to 70 - 80 lbf-ft (95 - 110 N·m).

## 4. RADIUS ROD

Radius rods are used to secure the axles in the proper transversal and longitudinal positions. Five radius rods are provided on the front axle suspension (four longitudinal and one transversal), four on the drive axle suspension (three longitudinal and one transversal) and also four on the tag axle with a layout similar to the drive axle. Refer to figures 1 and 2 for details. These rods transmit both braking and driving forces from the axles to the vehicle body.

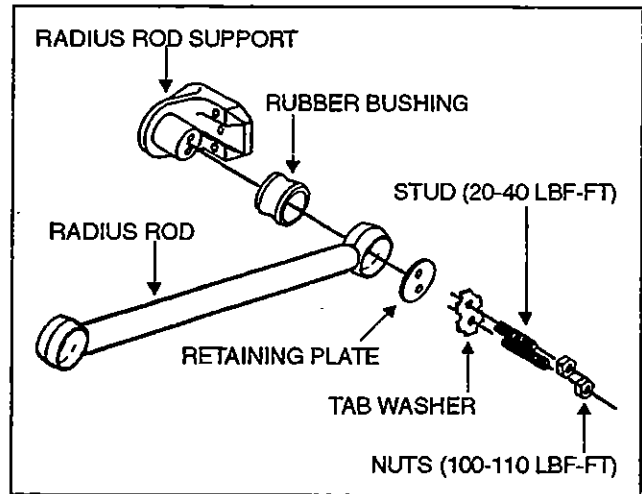

Figure 7

16010

### 4.1 Inspection

The following instructions apply to all radius rods used on this vehicle:

- Clean all parts thoroughly.
- Inspect radius rods for distortion and cracks. We recommend the "Magnaflex" process to detect cracks in the radius rod. Any damaged part should be replaced with a new one.

**Note:** New bushings should be used when rods are replaced.

- The radius rod bushings should be checked periodically for signs of shearing, deterioration, or damage. Any defective part should be replaced with a new one.

### 4.2 Removal

- Flatten the tab washer which secures the two retaining nuts (or bolts), then unscrew the nuts (or bolts) at each extremity of the radius rod (see fig. 7).
- Remove the retaining plates and radius rod ends from anchor pins, then remove the radius rod.

### 4.3 Bushing Removal

- Safely support the radius rod as shown in figure 8.

## Section 16: SUSPENSION

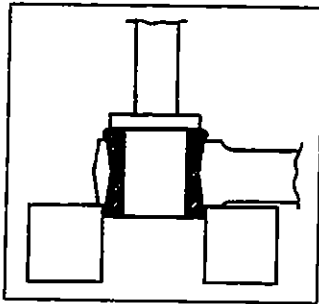

Figure 8

16011

2. Place a flat steel disc, slightly smaller than the outside diameter of the bushing (see fig. 8).
3. Using an arbor press or a suitable driving tool, press or drive the old bushing out of the rod and discard the bushing.

### 4.4 Bushing Installation

1. Lightly Spray the inner and outer surfaces of radius rod bushing with water.

**Caution:** No lubricant whatsoever is to be used on the rubber bushing.

2. Safely support the radius rod, and place new bushing on top of the radius rod end.
3. Place a block of wood on top of bushing and press on it manually.

4. If necessary, use an arbor press or a suitable driving tool. Press or drive the bushing into the radius rod end until it extends equally on both sides of the rod.
5. It is also possible to proceed differently. Place radius rod bushing on a plane surface. Spray a light coat of water on the inner and outer surfaces of radius rod bushing.
6. Take radius rod, align the bushing. Tap radius rod on bushing until latter is positioned correctly.

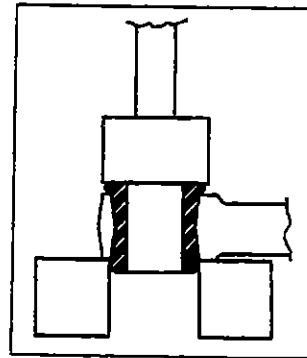

Figure 9

16012

### 4.5 Installation

1. Lightly Spray the anchor pin with water. Place the radius rod end over the anchor pin.

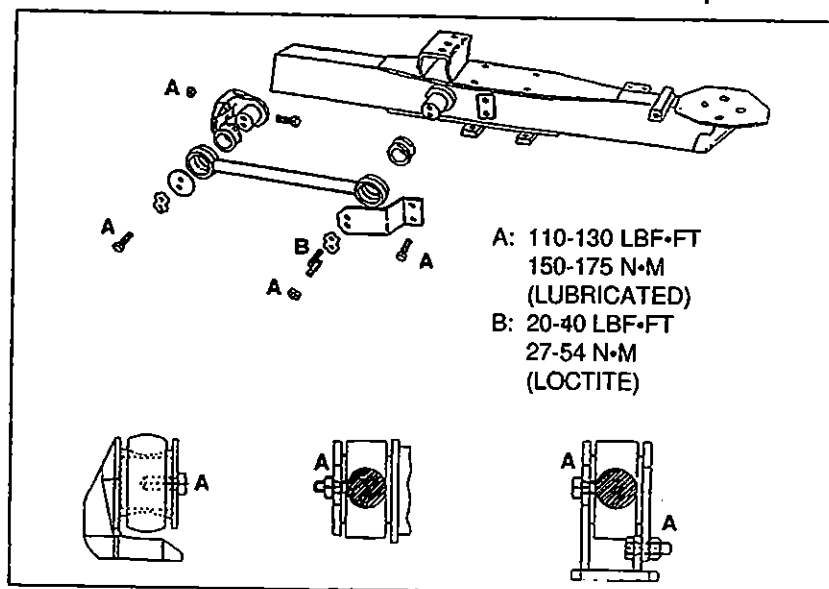

Figure 10

16013

2. Position the retaining plate. Install the tab washer and nuts (or bolts).

**Caution:** Always use new tab washers at installation.

3. Tighten the nuts (or bolts) lightly, and repeat at the other end.
4. Refer to heading "Suspension height adjustment" later in this section, and set the vehicle to normal ride height.

5. With the vehicle at normal ride height, apply oil on threads and tighten all radius rod anchor pin nuts or bolts to 110 - 130 lbf-ft (150 - 175 N·m).

**Caution:** It is extremely important upon reconnection of the rods that the proper clearance height between the axle and body is maintained. Otherwise, the rubber bushings in radius rod ends will become preloaded, thus reducing the life of these parts.

## 5. SWAY BAR

A sway bar is provided on the front and drive axles to increase vehicle stability. It controls lateral motion (swaying movement) of vehicle.

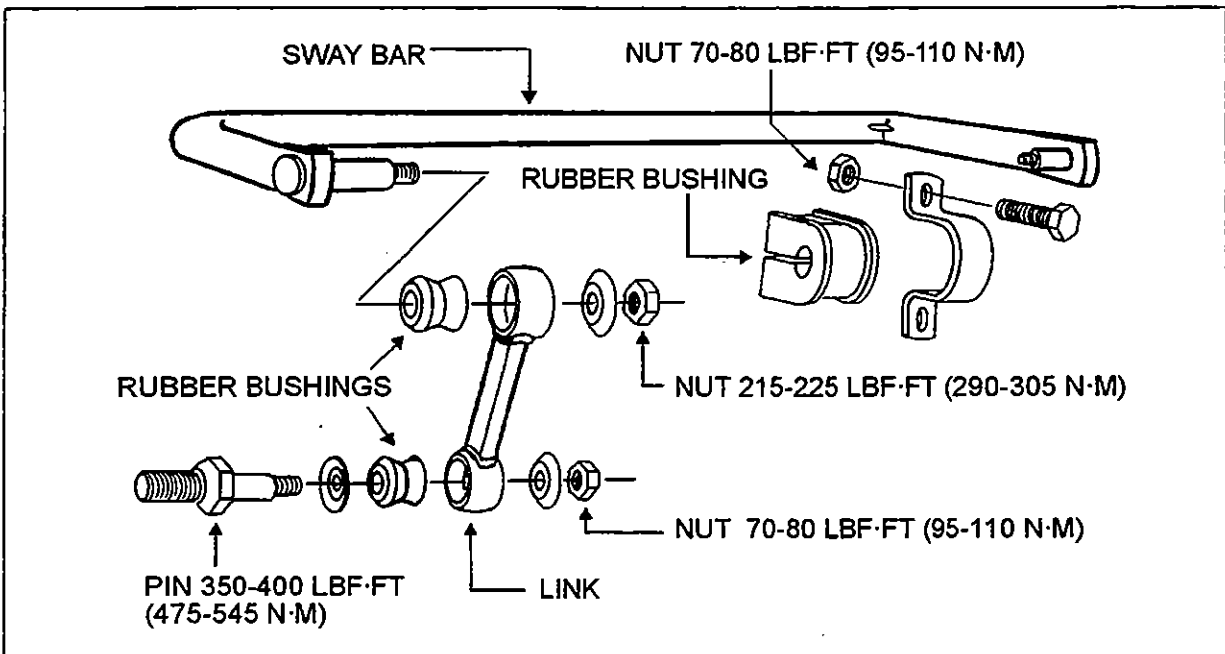

Figure 11

16014

### 5.1 Removal

1. Disconnect the two links from sway bar.
2. Safely support the sway bar. Unbolt the four bushing collars from subframe.
3. Remove sway bar.

**Note:** Sway bar bushings are slitted to ease their removal.

### 5.2 Installation

1. Loosely install the sway bar.
2. Tighten the eight bushing collar nuts to 70 - 80 lbf-ft (95 - 110 N·m).
3. Tighten sway bar link upper nuts to 215 - 225 lbf-ft (290 - 305 N·m) and lower nuts to 70 - 80 lbf-ft (95 - 110 N·m).

## 6. SUSPENSION AIR SYSTEM

### 6.1 Description

The suspension air system has its own air reservoir (accessory tank) which is located in the reclining bumper compartment. Pressurized air from the main tank (wet tank) flows through a pressure protection valve (PR-2) and an air filter which are both located in front service compartment, and then flows to the accessory air tank.

The pressure protection valve (PR-2) is mounted to the supply port of the air filter. This valve controls the pressure at which compressed air would be delivered to the accessory air tank. The valve remains closed until a preset pressure is reached (approximately 70 psi (485 kPa)). It then opens and passes air out the delivery port.

The main use for this valve is to protect the main air system by ensuring at all times a sufficient air pressure in the main system (i.e. air delivered to the accessories will be shut off in case of a decrease in pressure). Maintenance and repair information on the pressure protection valve is supplied in the applicable booklet, annexed to Section 12, "Brakes and Air System" under reference number SD-03-55.

### 6.2 Inspection

The following inspection should be performed at established service inspection periods. Performing these procedures will allow substandard performance to be discovered before the condition becomes bad enough to cause operator complaints and failure on a run.

1. Visually inspect the suspension air lines for evidence of chafing on metal parts or other damage.
2. Visually inspect the air springs for cracks, abrasion or other damage.
3. Replace any parts found to be damaged.

### 6.3 Air Line Test

With the main air system at normal operating pressure, coat all suspension air line connections and air spring mountings with a solution of soap

and water. Air leakage will produce soap bubbles. Any leak found must be corrected as no air leakage is permissible.

### 6.4 Air Tank Maintenance

Refer to Section 12, "Brakes and Air System" under heading "Air Reservoir Maintenance" for complete instructions on air tank maintenance.

## 7. SUSPENSION HEIGHT ADJUSTMENT

The flow of pressurized air from the accessory air tank to the air springs is controlled by three height control valves. These valves are mounted to the subframe and connected to the axles through an arm and link connection. This connection allows the valves to apportion air pressure in the springs to the vehicle load, maintaining normal ride height.

Immediate response height control valves increase or decrease the air pressure in the suspension system as required. One height control valve is located at center of front axle, and regulates air to front axle air springs in order to maintain the vehicle at the required height. Two are located at the drive axle, one on each inner side of rear wheelhouse. Refer to figure 12.

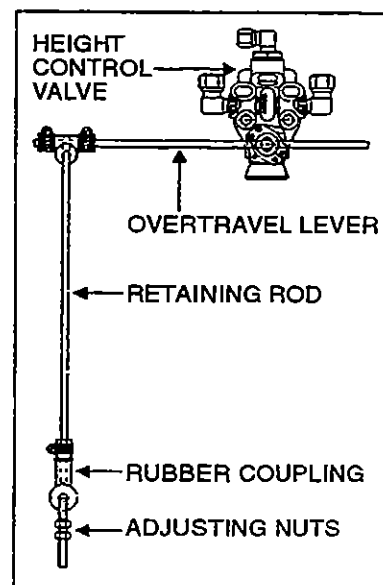

Figure 12

16015

The appropriate vehicle body height is obtained by measuring the clearance of the air springs installed on the front and drive axles. The clearance should be  $12 \pm 0.25$ " ( $305 \pm 6$  mm) for the air springs installed on the front axle and  $11.5 \pm 0.25$ " ( $292 \pm 6$  mm) for those installed on the drive axle. Refer to figure 23 to identify the correct location where the measure has to be taken. At this point, it should not be necessary to make an adjustment under normal service conditions. However, if an adjustment is required, change the position of the overtravel lever in relation to the overtravel control body. The lever should be moved up to raise the height of vehicle, and down to lower it. Check that main air pressure is at normal operating pressure and raise the vehicle to the specified height.

**Caution:** Always adjust on "fill cycle". If it is necessary to lower vehicle height, release sufficient air to be well below height, and adjust to height or fill cycle.

To adjust suspension height, proceed as follows:

1. With the vehicle at normal operating air pressure, check the air spring clearance as illustrated in figure 13. This clearance should be  $12 \pm 0.25$ " ( $305 \pm 6$  mm) for the front axle air springs and  $11.5 \pm 0.25$ " ( $292 \pm 6$  mm) for those on the drive axle.

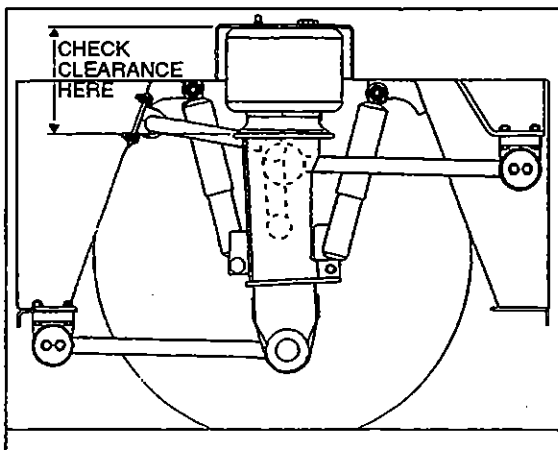

Figure 13

16018

**Note:** The measure should be taken from under the upper air spring support on sub-frame to top of the lower air spring support on axle (refer to fig. 13 for more details). If adjustment is required, begin with the drive axle.

2. Loosen the two adjusting nuts on the connecting rod of height control valve to raise or lower the overtravel lever until the desired clearance is reached.
3. If there is not enough play on adjusting nuts, it is possible to make further adjustments by loosening the clamp on the rubber coupling and bringing it up or down.

**Note:** Allow suspension to stabilize before taking reading.

4. When the desired height is obtained, tighten adjusting nuts and clamp.

## 8. HEIGHT CONTROL VALVE

### 8.1 Operation

The height control valves automatically add air to, or release air from air springs to maintain constant suspension height regardless of load, or load distribution. Each valve adjusts independently according to the following conditions:

#### 8.1.1 Loading Position

As the load increases and lowers the vehicle body, the overtravel lever commands the height control valve to add air to air springs.

#### 8.1.2 Neutral Position

When vehicle body reaches the normal ride height, the height control valve overtravel lever reaches the "neutral" position and keeps both the supply and exhaust ports closed to ensure normal ride height is maintained. This condition remains static until the vehicle load is altered.

#### 8.1.3 Unloading Position

As the load decreases and raises the vehicle body, the overtravel lever commands the height control valve to release air from air springs.

### 8.2 Maintenance

The height control valve requires no periodic maintenance. Height control valve linkage oper-

## Section 16: SUSPENSION

ates on rubber bushings and no-lubrication should be attempted at this point.

### 8.2.1 Removal and Installation

Before disconnecting any height control valve air lines, securely support the vehicle by its jacking points on the body. Refer to heading "Vehicle Jacking Points" in Section 18, "Body".

1. Exhaust air from air system by opening the drain cock on accessory air reservoir. Remove height control valve as follows.
2. Disconnect overtravel lever from link and pull down lever to exhaust remaining air from air springs.
3. Disconnect air supply and delivery lines from the height control valve. Cover ends of the lines with tape.
4. Remove the two nuts retaining the height control valve to the mounting bracket, then remove valve assembly.

Reverse removal procedure to replace height control valve. After installation, check for leakage using a soap and water solution.

### 8.2.2 Air Leakage Test

**Note:** The following procedure applies when valve assembly has been removed from vehicle.

1. Clean the exterior of valve assembly.
2. Connect air pressure line to air inlet port, then allow air pressure build-up (70-100 psi (480-690 kPa)).
3. Dip the valve assembly in a container of water, and watch for air bubbles when the overtravel lever is in the center position. No air should escape from any point of the valve assembly.
4. If bubbles appear from the air spring port, this is an indication that the air inlet valve assembly is defective and must be replaced.
5. Remove air pressure line from air inlet fitting and connect it to the air spring port. If bubbles appear at the air inlet check valve port, this is an indication that check valve unit is defective and must be replaced.
6. If bubbles appear at the exhaust port, this is an indication that the exhaust valve assembly is defective and must be replaced.

7. If bubbles appear around edge of valve cover plate, the cover plate gasket must be replaced.
8. If no leaks are found, remove valve assembly from water, then with air pressure still connected to the air spring port, actuate overtravel lever to remove any excess water which may have entered exhaust valve chamber. Remove air line, connect it to the air inlet port, and repeat operation to remove water from the air inlet valve chamber.

## 9. FRONT KNEELING AND HI-BUOY SYSTEM

The kneeling system is used to lower front of vehicle. This allows passengers to board the vehicle with greater ease. The kneeling action is achieved by exhausting air from the front air springs (bellows). This system bypasses the height control valve to provide a fast up and down movement of the front suspension. Only seven seconds are required to lower vehicle from normal level to the lower position, and approximately the same time to raise the vehicle from lower position to normal level. The quick response is achieved by an auxiliary air tank installed beside the secondary air tank (for exact position, refer to section 12, "Brake and Air System"). This tank provides sufficient air supply to the kneeling system for some successive operations.

The system is provided with two safety features; first, a speed switch will enable the kneeling system to work only under 5 mph (8 km/h). Secondly, the parking brake is automatically applied, and a limit switch will keep it applied as long as the vehicle has not returned to a certain height where the driver will be able to manually remove the parking brake.

The purpose of the hi-buoy function in this system is to raise the front end of the vehicle to allow passengers to board the vehicle with greater ease. It is also used to allow an extra ground clearance for particular situations. In normal conditions, the height control valve is in operation and only the hi-buoy can be operated.



## 9.1 Principle of Operation

Refer to figure 14.

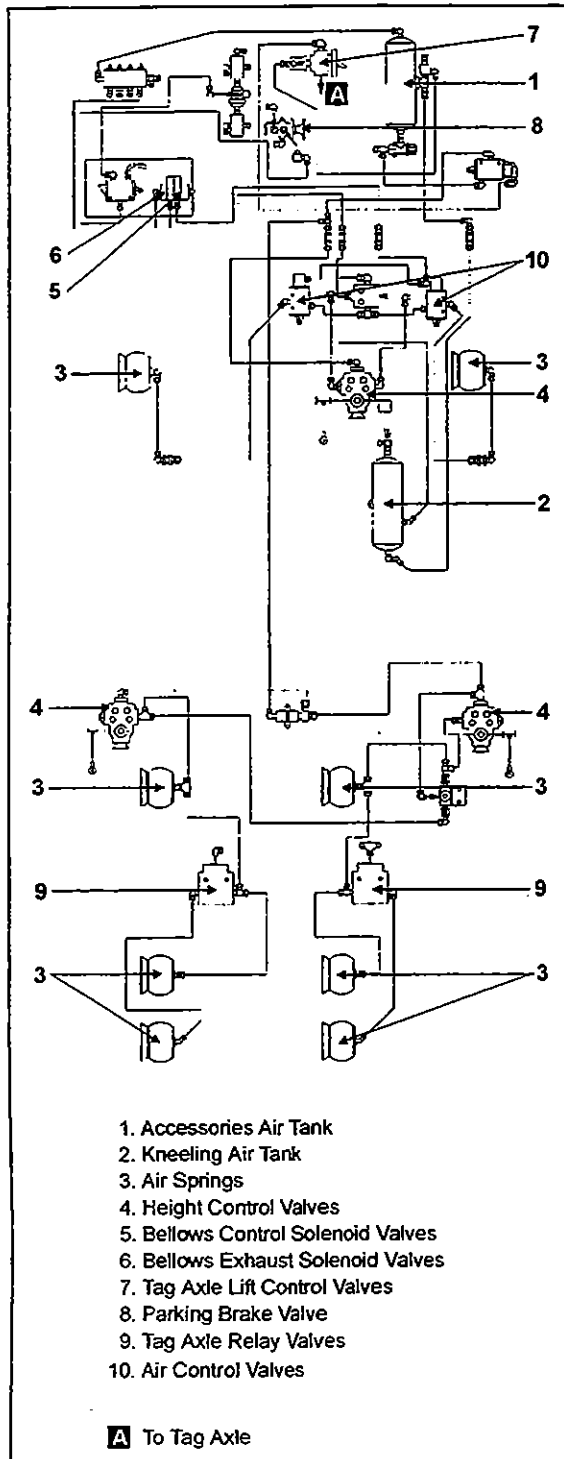

Figure 14

16017

### DOWN:

Both the bellows control and bellows exhaust solenoid valves are energized, so the air control valves release air from front air springs. The height control valve is bypassed to ensure no air is forwarded to air springs while lowering the front suspension.

### UP:

Only the bellows control solenoid valve is energized, so the air coming from the kneeling air tank is routed through air control valves, and up to front air springs. The height control valve is bypassed until the kneeling proximity switch signals the kneeling module to cut off the bellows control solenoid valve, about 1" (25 mm) below normal ride height. The final height adjustment is achieved by the height control valve.

### HI-BUOY FUNCTION:

Only the bellows control solenoid valve is energized, so the air coming from the kneeling air tank is routed through air control valves, and up to front air springs. The height control valve is bypassed during the up motion.

## 9.2 Maintenance

Since the kneeling action is issued from both the air system and electrical system, refer to Section: 12, "Brake and Air System" and Section 06, "Electrical System".

For diagnosis and understanding of the system, refer to wiring diagrams, and to figure 14, along with the appropriate air system schematic diagram annexed to Section 12, "Brake and Air System".

## 9.3 Bellows Control and Bellows Exhaust Solenoid Valves

### 9.3.1 Removal and Installation

1. On the rear side of steering compartment, locate both the bellows control and bellows exhaust solenoid valves.
2. Identify hoses and wires to ease reinstallation. Disconnect solenoid wires and the three flexible black hoses from solenoid valves.

3. Unscrew and remove the control solenoid valve and exhaust solenoid valve assembly. Place on a clean working place.

Reverse removal procedure to reinstall.

**Caution:** *Any cable tie that has been cut during removal procedure should be replaced with a new one.*

## **10. HI-BUOY SYSTEM**

The purpose of the hi-buoy system is the raise vehicle body about 4" (100 mm) in order to increase ground clearance to board a ferryboat, to avoid a curb, etc... This system can be put into service during normal vehicle operation.

### **10.1 Principles of Operation**

The hi-buoy system is added over the front kneeling and hi-buoy system. The front end uses the same valves as the kneeling. A solenoid valve is added to send air to the double shuttle valves for the rear end. It uses the same dash switch as the kneeling.

**UP:**

The air coming from the control valve, flows through double shuttle valves, to supply air springs. The double shuttle valves prevent height control valves from releasing air from air springs.

**DOWN:**

The control valve, on the dashboard, cuts off air supply, so the double shuttle valves allow height control valves to accomplish their function. Height control valves release air from air springs until suspension reaches the normal ride height.

## **11. LOW-BUOY SYSTEM**

The purpose of the low-buoy system is to lower the whole suspension about 4" (100 mm) in order to reduce the overall height for low clearances. This system can be put into service during normal vehicle operation.

### **11.1 Principles of Operation**

On H3-41 and H3-45, the low-buoy is added over the front kneeling and hi-buoy system. The control valve on the right console panel sends an electric signal from its pressure switch to control the front suspension as at kneeling. It also removes air from a relay valve that exhausts air supply to all leveling valves and the quick release in the rear section. Air from the rear suspension can then be depleted through the check valve-quick release assembly.

**DOWN:**

The control valve, on the dashboard, cuts off air supply, so air is released from air springs. A relay valve prevents height control valves from supplying air springs.

**UP:**

The control valve, on the dashboard, supplies air to close the passage between both the delivery and supply ports. A relay valve opens and provides air springs until the suspension reaches the normal ride height.

## **12. "LEVEL-LOW" LEVELING SYSTEM**

The purpose of the "level-low" leveling system is to adjust suspension in three separate points (front, rear right and rear left) in order to level vehicle body. This system can be put into service when the ignition key is turned to the "ON" position, and must be used only when the parking brake is applied.

The "level-low" warning light on the dashboard indicates that the selector knob is not in the "DRIVE" position.

## 12.1 Principles of Operation

Refer to figure 15.

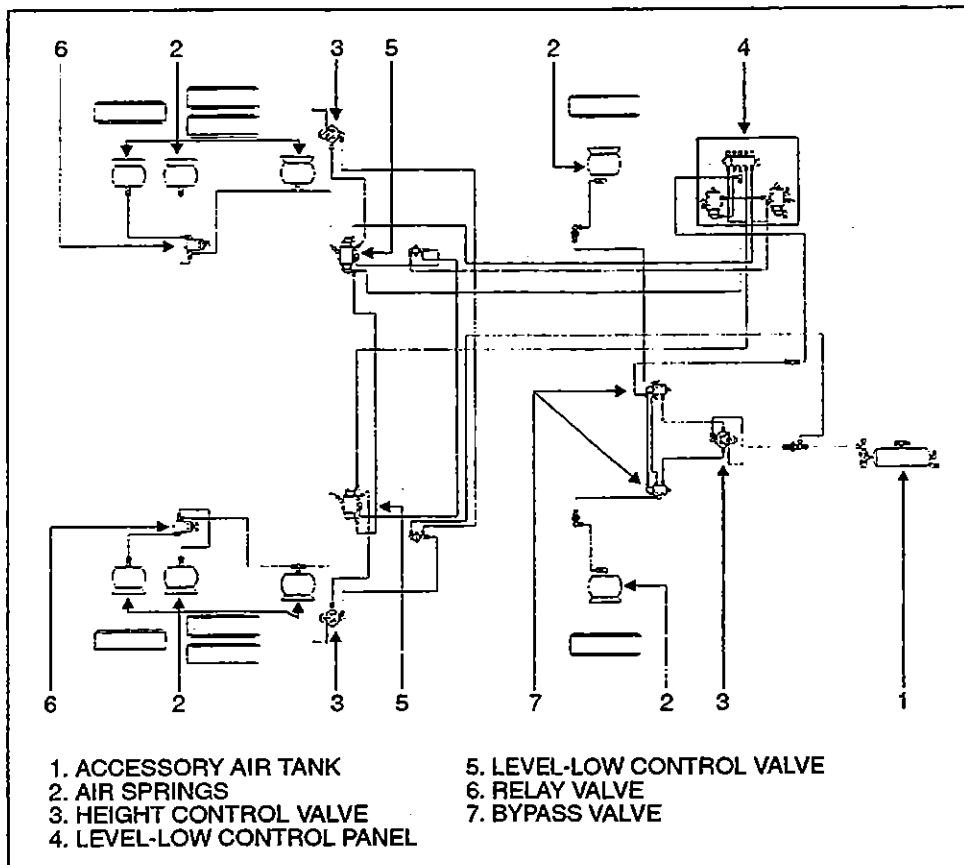

Figure 15

16016

### DOWN:

The (front/rear right/rear left) control solenoid valve supplies air to the (front/rear right/rear left) five-way three-position air control valve, which bypasses the (front/rear right/rear left) height control valve, and opens a passage to allow the air control and exhaust valve to release air from (front/rear right/rear left) air springs.

### UP:

The (front/rear right/rear left) control solenoid valve supplies air to the (front/rear right/rear left) five-way three-position air control valve, which bypasses the (front/rear right/rear left) height control valve, and opens a passage to allow the air control and exhaust valve to supply air to (front/rear right/rear left) air springs.

### DRIVE:

When the ignition key is turned to the "ON" position with selector knob in the "DRIVE" position, the drive control solenoid valve supplies air to all five-way three-position air control valves, each one opening a passage to allow height control valves to accomplish their function.

When the ignition key is turned to the "OFF" position and selector knob to the "DRIVE" position, the air is entrapped between air springs and five-way three-position air control valves to ensure the adjusted level will be kept.

**Warning:** Never move vehicle with selector knob in any other position than the "DRIVE" position.

### 13. TROUBLESHOOTING

Bellows deflate over time	Defective check valve assembly Defective exhaust valve assembly Leak in air line and/or bellows Defective valve cover, rubber O-rings or gasket	Replace check valve assembly Replace exhaust valve assembly Replace air line or bellows Replace valve cover, O-rings or gasket
Bellows raise to full height and fail to exhaust air pressure	A clogged exhaust screen in height control valve assembly A combination clogged exhaust screen and defective air inlet valve assembly	Remove and clean screen Clean exhaust screen and replace air inlet valve assembly
Erratic valve action	Dirt or foreign matter in the air valve lever chamber  Defectives valves	Remove valve cover and blow out dirt  Install cover using new gasket Overhaul height control valve assembly
Vehicle body fails to level to satisfactory ride height	Improper height control valve over-travel lever adjustment	Adjust lever as directed

### 14. PARTS SPECIFICATIONS

#### Front and tag axle air springs

Make ..... Goodyear Tire and Rubber  
Model ..... Roll-over volume can  
Type ..... 1100  
Diameter ..... 11" (279 mm)  
Supplier number ..... 1R12-319  
Prévost number ..... 63-0125

#### Drive axle air springs

Make ..... Goodyear Tire and Rubber  
Model ..... Roll-over volume can  
Type ..... 1100  
Diameter ..... 11" (279 mm)  
Supplier number ..... 1R11-089  
Prévost number ..... 63-0105

#### Front axle shock absorbers

Make ..... Gabriel  
Color ..... White  
Collapsed length ..... 15.47±0.125" (39,29±0,32 cm)  
Extended length ..... 24.5±0.125" (33,32±0,32 cm)  
Supplier number ..... 680422  
Prévost number ..... 63-0134

#### Drive and tag axle shock absorbers

Make ..... Monroe  
Type ..... Gas Magnum  
Collapsed length ..... 15.38" (39,05 cm)  
Extended length ..... 23.63" (60,01 cm)  
Supplier number ..... 650407  
Prévost number ..... 63-0127

#### Height control valve

Make ..... Neway  
Quantity used ..... 3  
Supplier number ..... 905-54-241  
Prévost number ..... 63-0120

#### Bellows control and exhaust solenoid valve assembly

Make ..... Norgren  
Supplier number ..... D0043B  
Prévost number ..... 64-1130

#### Solenoid valve manifold

Supplier number ..... D0043B  
Prévost number ..... 64-1130  
Coil  
Voltage ..... 24 V DC  
Current draw ..... 29 ampere  
Supplier number ..... 54932-27  
Prévost number ..... 64-1144

**Valve (3 ways, 2 positions)**

Supplier number ..... K41EAOO-KH1-KS6  
 Prévost number ..... 63-0081  
 Repair kit (spool) Supplier number ..... 54237-65  
 Repair kit (spool) Prévost number ..... 64-1169

**Radius rod bushing**

Make ..... Prévost  
 Prévost number ..... 63-0021

**Sway bar bushing**

Make ..... Prévost  
 Prévost number ..... 13-0953

**Shock absorber and sway bar link bushings**

Make ..... Monroe  
 Supplier number ..... 45380  
 Prévost number ..... 63-0062

**15. TORQUE SPECIFICATIONS**

- 1- Shock absorber pin ..... 350-400 lbf-ft (475-545 N·m)
- 2- Shock absorber pin nut ..... 70-80 lbf-ft (95-110 N·m)
- 3- Radius rod stud ..... 20-40 lbf-ft (27-54 N·m)
- 4- Radius rod retaining nut or bolt ..... 110-130 lbf-ft lubricated (150-175 N·m lubricated)
- 5- Radius rod support nut ..... 110-130 lbf-ft lubricated (150-175 N·m lubricated)
- 6- Axle attachment nut ..... 425-475 lbf-ft (580-645 N·m)
- 7- Air spring stud nut ..... 20-25 lbf-ft (27-34 N·m)
- 8- Sway bar link pin stud ..... 350-400 lbf-ft (475-545 N·m)
- 9- Sway bar link lower nut ..... 70-80 lbf-ft (95-110 N·m)
- 10- Sway bar link upper nut ..... 215-225 lbf-ft (290-305 N·m)
- 11- Sway bar bushing collar bolt ..... 70-80 lbf-ft (95-110 N·m)

**Note:**

*During assembly, use "Loctite 242" (Prévost number 68-0038) with item 1, 3 and 8.  
 After assembly, apply "anti-seize compound" (Prévost number 68-0064) on all nuts.*

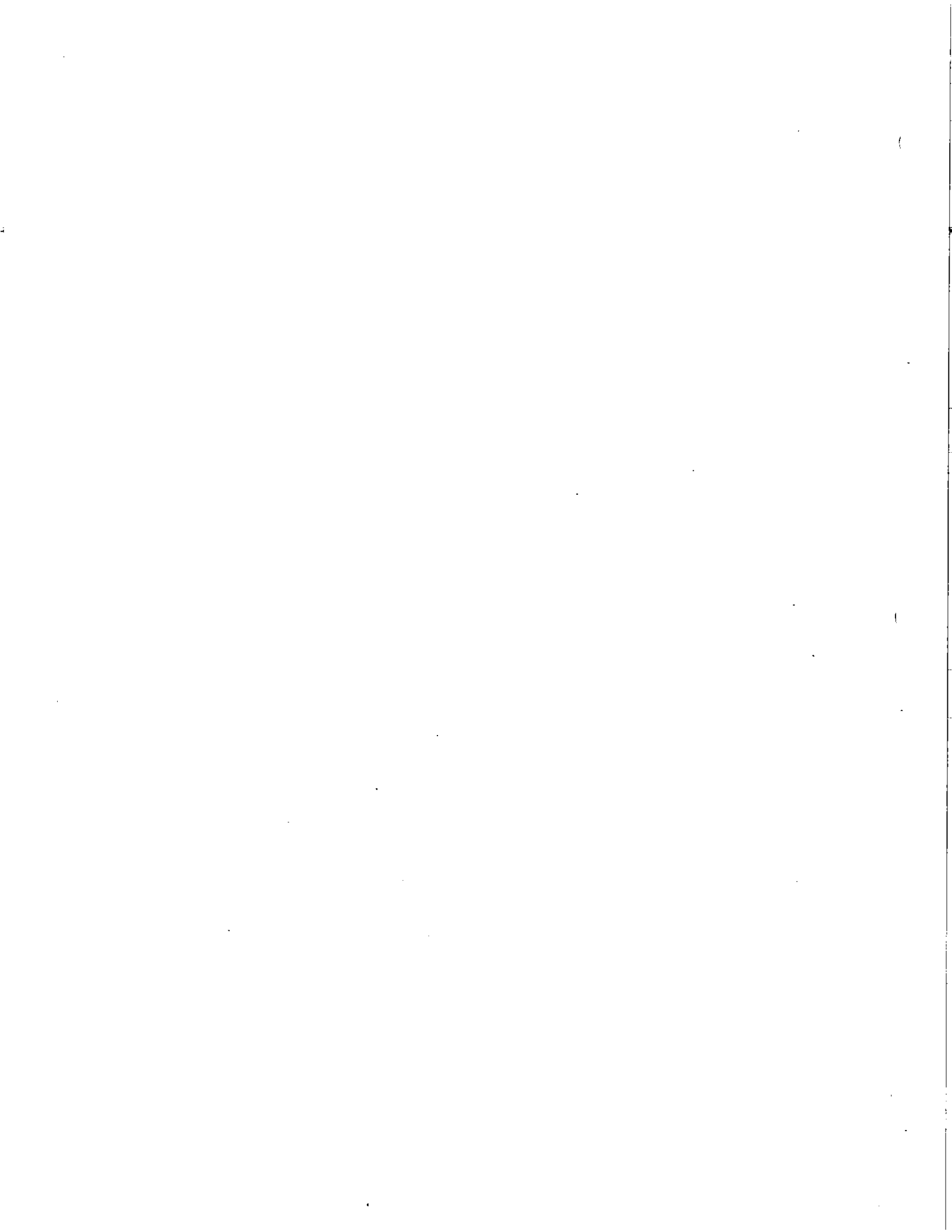



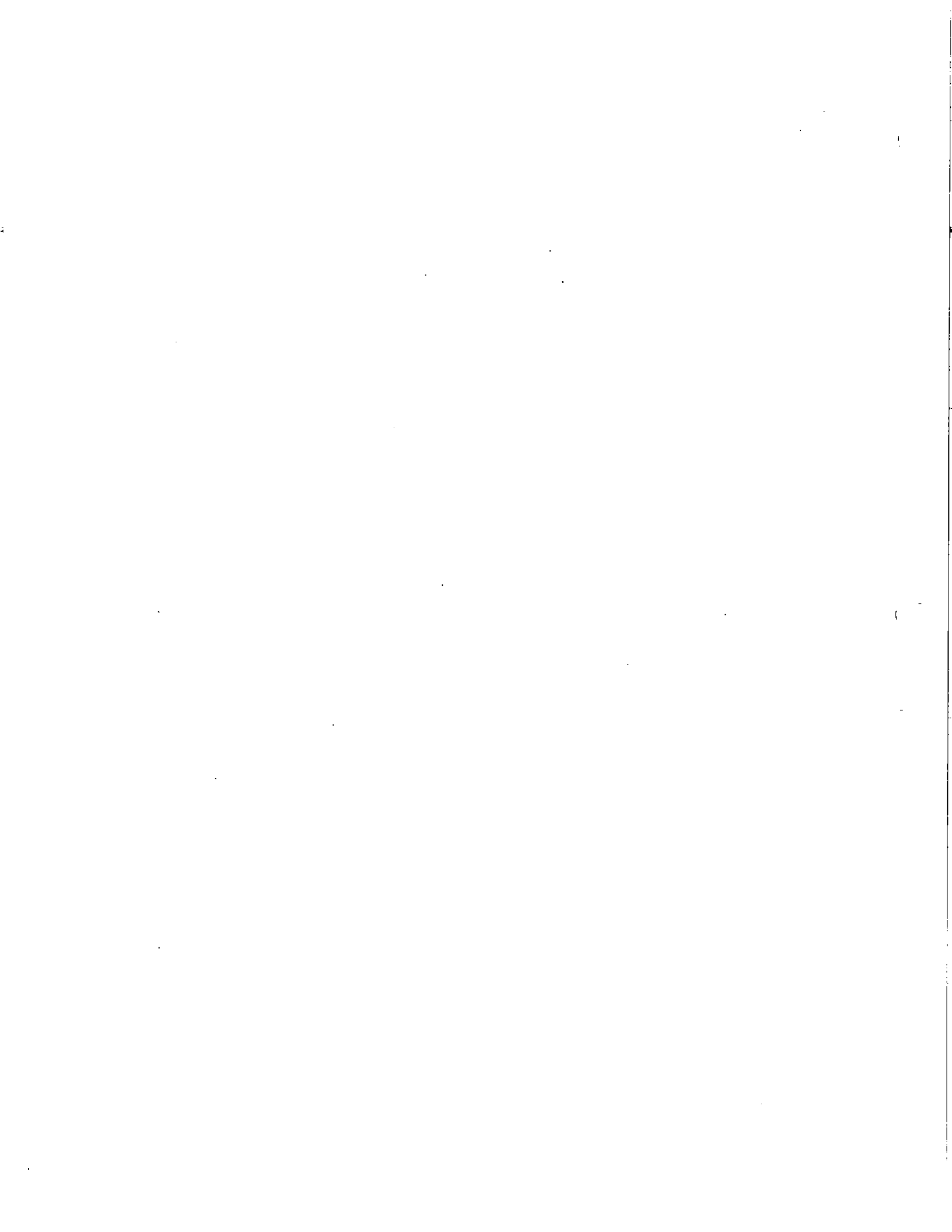



# SECTION 18: BODY

## CONTENTS

1. COMPARTMENT DOORS.....	3
1.1 H3-41.....	3
1.2 H3-45.....	4
2. STRUCTURE .....	4
2.1 Description .....	4
2.2 Welding .....	4
3. EXTERIOR MAINTENANCE .....	5
3.1 Corrosion Prevention .....	5
4. FIBERGLASS REPAIR .....	5
4.1 Repair with Fiberglass Cloth.....	6
4.2 Repair with Fiberglass Paste .....	6
4.3 Typical Fiberglass Repair Procedure .....	6
5. PAINTING.....	8
5.1 Safety .....	8
5.2 Surface Preparation .....	8
5.2.1 Aluminum Surface.....	8
5.2.2 Fiberglass Surface .....	8
5.2.3 Washing .....	8
5.3 Primer Application .....	8
5.3.1 Aluminum Surface.....	8
5.3.2 Fiberglass Surface .....	8
5.4 Painting.....	8
5.4.1 PPG Paint Application.....	8
5.4.2 PPG Clear Application .....	9
6. COACH FRONT AND REAR BUMPERS.....	9
6.1 Repair of Superficial Damage .....	9
6.2 Repair of Substantial Damage.....	10
6.3 Refinishing procedure .....	10
6.3.1 Surface Preparation .....	11
6.3.2 Prime Coat .....	11
6.3.3 Color Coat .....	11
6.4 Front Bumper Removal and Installation .....	11
6.5 Rear Bumper Removal and Installation.....	12
7. COACH ENTRANCE DOOR .....	12
7.1 Operation.....	12
7.1.1 Emergency Exit Valves.....	12
7.1.2 Without air and With or Without Electricity.....	12
7.1.3 With Air and Without Electricity .....	12
7.2 Adjustment and Maintenance .....	13
7.2.1 Horizontal and Vertical Adjustments.....	13

**Section 18: BODY**

---

7.2.2	Depth Adjustment.....	13
7.2.3	Rod End With Bearing Adjustment.....	14
7.2.4	Lubrication.....	14
7.3	Hydraulic system.....	14
7.3.1	Filling.....	14
7.3.2	Bleeding.....	15
7.3.3	Piston Side Bleeding.....	15
7.3.4	Cylinder Side Bleeding.....	15
7.4	Specifications.....	15
8.	BAGGAGE COMPARTMENT DOORS.....	17
8.1	Adjustment.....	17
9.	ENGINE COMPARTMENT DOOR.....	20
10.	COACH SIDE WINDOWS.....	20
10.1	Removal and Installation.....	21
10.2	Emergency Exit Window Adjustment.....	22
11.	ADHESIVE MOUNTED WINDOWS.....	22
11.1	Replacement.....	22
12.	WINDSHIELD.....	24
12.1	Removal.....	24
12.2	Installation.....	24
12.3	Rubber Extrusion and Windshield Installation.....	25
13.	ROOF ESCAPE HATCH.....	27
13.1	Maintenance.....	27
13.2	Repair.....	27
13.3	Sealing.....	28
13.4	Removal and Installation.....	28
14.	PASSENGER SEATS.....	28
14.1	Rotating Seat.....	28
14.2	Removing Fixed Seats.....	28
15.	UPHOLSTERY MAINTENANCE.....	29
15.1	Routine Cleaning.....	29
15.2	Dry Cleaning.....	29
15.3	Cleaning With Covers in Place.....	29
16.	VEHICLE JACKING POINTS.....	30
16.1	Body Jacking Point.....	30
16.2	Axle Jacking Points.....	30
16.3	Jacking the Tag Axle.....	31
17.	TOWING THE VEHICLE.....	31
17.1	Lifting and Towing.....	31
17.2	Towing Without Lifting.....	31

## 1. COMPARTMENT DOORS

- |                                      |   |
|--------------------------------------|---|
| 1. Engine air intake duct            | 10. Front service compartment             |
| 2. Engine compartment R.H. side door | 11. Front electric compartment            |
| 3. Main power compartment            | 12. Fresh air inlet duct                  |
| 4. Baggage compartment               | 13. HVAC compartment                      |
| 5. Fuel filler door                  | 14. Fuel filler door                      |
| 6. A/C condenser                     | 15. Rear electric compartment             |
| 7. Entrance door operating switch    | 16. Radiator                              |
| 8. Entrance door                     | 17. Engine compartment rear door          |
| 9. Reclining bumper compartment      | 18. Retractable back-up camera (optional) |

### 1.1 H3-41

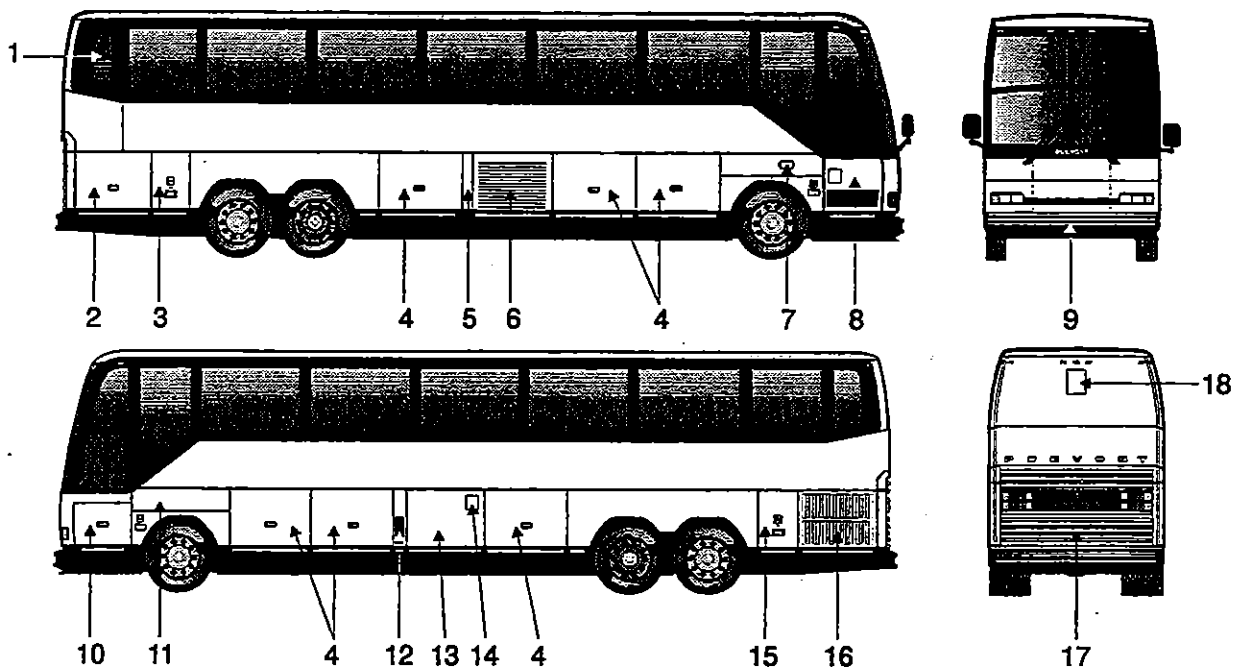

Figure 1

18055

## 1.2 H3-45

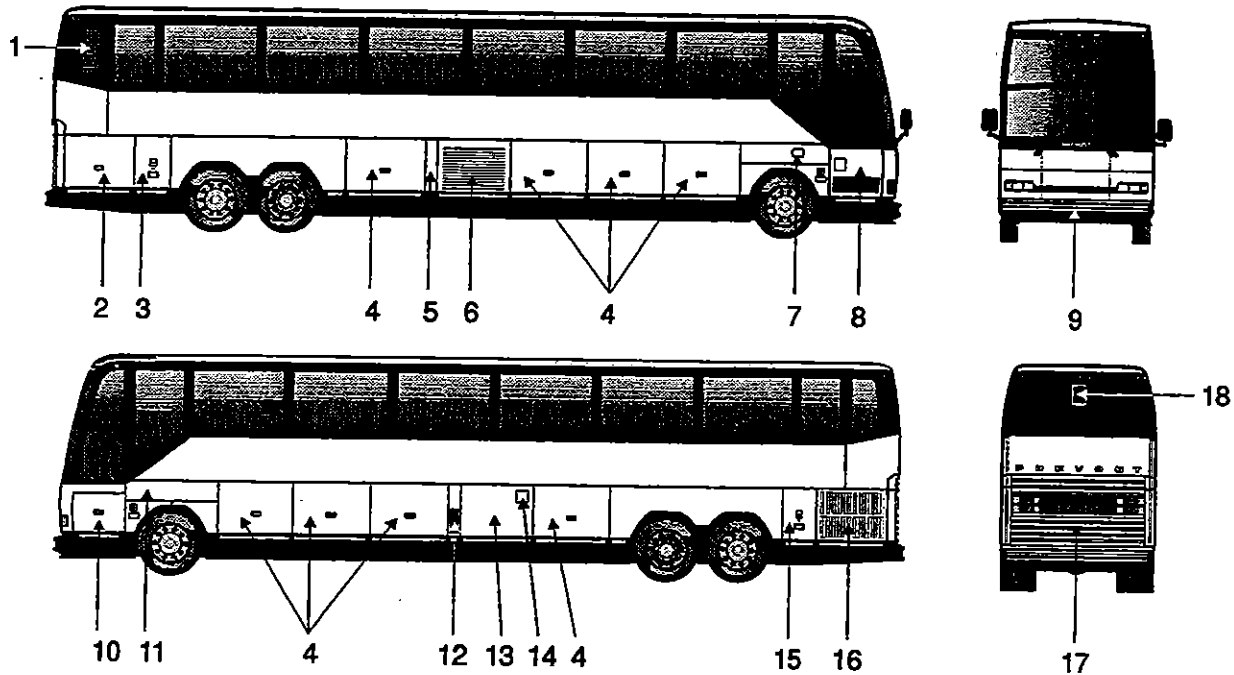

Figure 2

18054

## 2. STRUCTURE

### 2.1 Description

The body of the H3-41 and H3-45 is an integral structure made of 14, 16 and 18 gauge welded and braced high tensile steel and stainless steel members. The roof arches are made with cold rolled, electrically welded (CREW) steel tubes, 1 1/2" x 2" x 14 gauge. The inside is filled with urethane foam and the exterior is primed. The roof is a one-piece aluminum sheet, stretched and riveted all around. The front and rear caps are made of fiber-composite material. The front cap has a carbon-reinforced molded windshield cross-member. The front subframe is made of open sections of high-strength low-alloy steel (Corten). These open sections permit a better application of primer and undercoating, and does not trap moisture. The rear subframe is made of closed sections of carbon steel filled with polyurethane foam. The floor is made of 2 layers of 1/2" (13 mm) thick plywood separated by a 1/8" (3 mm) insulation to reduce power train and road noises.

### 2.2 Welding

The following welding rods should be used when making welding repairs to the structure:

Application	Diameter	A.W.S.
Stainless steel to stainless steel or Corten, light gauge	3/32" (2,4 mm)	No 308
Stainless steel to stainless steel or Corten, heavy gauge	1/8-5/32" (3,2-4 mm)	No 308
Corten to Corten, light gauge	3/32-1/8" (2,4-3,2 mm)	No 6011
Corten to Corten, heavy gauge	3/32-5/32" (2,4-4 mm)	No 7018

Since welding is a procedure that may be carried out either as specific instructions from Prévost or by an independent decision of the owner, the following information pertaining to welding should be read before beginning any welding procedure. The prohibitions and requirements outlined below must be followed during welding procedure.

- 1: Welding must be done only by a qualified and experienced person.
2. Adequate ground contacts and shields must be positioned as required to protect components from damage due to heat, contact by weld splatter, arcing, or other potentially damaging events associated with welding.
3. Turn the battery main disconnect switch to "OFF". Disconnect DDEC, ABS, electronically controlled transmission, and optional preheater control modules in order to protect these systems from voltage surges.
4. Always wear the appropriate safety equipment.
5. Weld in clean and well-ventilated area, and always have an appropriate fire extinguisher within your reach.

### 3. EXTERIOR MAINTENANCE

Regular washing to remove dust and dirt is recommended. See "Operator's Manual" for more details on washing and cleaning your vehicle.

#### 3.1 Corrosion Prevention

Preventive maintenance is a key factor in avoiding corrosion and must be considered as part of the regular service intervals. The entire underside of the vehicle is sprayed with a heavy application of asphalt base undercoating.

The operating environment vehicle is subjected to will largely influence the amount of dirt and corrosion that will accumulate over a given period. Corrosion is one of the most costly factors of part failure and shortened part life. It is, however, an item that can be controlled when it is conscientiously looked for and the proper steps are taken in a timely manner.

Certain areas of the coach are more vulnerable to corrosion than others, and it is these areas that should be addressed. For example, the rear baggage compartment bulkhead in the rear wheelhousing area contains many key components and should be examined regularly for corrosion. Other areas include the front wheelhousing area and engine compartment.

Road splash will affect undercarriage, condenser coil and engine compartment. These areas must

be thoroughly cleaned to remove dirt accumulations from flanges, channels and ledges. These places accumulate dirt and salt and hold it in direct contact with steel and aluminum surfaces. Use an understructure high pressure spray as part of a regular wash. Damaged undercoating or paint should be promptly repaired before corrosion can start.

Frequency of wash periods depends on operating conditions. During periods of exposure to salt, daily washing as described above is recommended. If underbody parts show evidence of rust or corrosion, treat as follows:

1. Remove dirt, grease and oil by solvent washing.
2. Remove corrosion as well as all loose coating by sanding with a wire brush or sandblasting.

**Caution:** Sandblasting can be used for cleaning bulkheads, brackets and other structural members. It should not be used for exterior side panelling. Extreme care should be taken not to sandblast excessively.

3. Apply correct primer, paint and undercoating after removing all corrosion to prevent further damage.

### 4. FIBERGLASS REPAIR

All repairs to fiberglass parts consist of filling the damaged area with fiberglass cloth and resin or strand fiberglass and resin. The repair is allowed to harden and then the finishing operations are performed. Use of the various materials is determined by the type of repair to be made. Large holes, torn sections and separate joints require the adhesive qualities of the resin and the reinforcing qualities of the fiberglass. Small dents, scratches or pits can be repaired using resin and strand fiberglass and filler mixed into paste. Instructions for either mix are explained under their respective headings in this section.

For best results when making repairs, temperature should be between 70 and 75 °F (21-24 °C). Some people experience a skin reaction to resins. In such cases, wipe skin off with denaturated alcohol or a good thinner. Use of protective hand cream is recommended.

## Section 18: BODY

**Warning:** *Always wear a respirator and goggles when grinding or sanding.*

Extreme care must be taken if the sander is electrically operated, as dust from some resins is combustible when subjected to sparks or open flames. The proper tool for sanding resin is a low speed, air driven disc sander with a water attachment or a dry sander having a vacuum bag. Either will eliminate flying glass and resin dust.

The following additional tools and materials will assist in making repairs: hacksaw blade, assorted files, emery paper or cloth (150 or finer), scissors or tin snips, wax paper or cellophane sheets, a 3" (75 mm) paint roller, paint brush, putty knife, acetone and one or more heat lamps.

### 4.1 Repair With Fiberglass Cloth

Where necessary, sand paint away around damaged area and scrape away undercoating, if any, and wipe clean with solvent. Grind or file the damaged area to form a "V" at the broken or cracked portion. Sides of "V" should have a shallow pitch for maximum bonding area.

**Note:** *Roughening the surface improves adhesion of resin.*

If part is warped from original shape, use clamping equipment to straighten the surface. Preheat area to be repaired with one or two heat lamps placed 12 to 15 inches (305-380 mm) from repair.

**Caution:** *Temperature should not exceed 200 °F (93 °C) in order to avoid distortion.*

Cut fiberglass cloth with scissors or tin snips, 1 to 3 inches (25-75 mm) larger than area to be repaired. Build area to desired height.

Mix resin and hardener following instructions on their containers. Saturate layers of fiberglass with mixture and place laminates over damaged area. Smooth out wrinkles and make sure general contour of area is maintained. Bubbles and wrinkles can be eliminated with a roller.

**Caution:** *The pot life of the mix is approximately 15 minutes. Any accidental contamination to the skin, clothing, tools, etc. must be removed within this period. Use acetone to remove uncured resin.*

Heat resin material again by placing heat lamps 12 to 15 inches (305-380 mm) from repaired area. Allow 12 to 15 minutes for repair to cure. After repair is cured, grind, file or sand to contour. Files other than body files may be more suitable. Featheredge and finish sanding.

If small pits or irregularities appear after making repair, correct by using a liberal amount of chopped strand or filler mixed with resin to form a paste. Refer to heading "Repair with Fiberglass Paste" in this section.

### 4.2 Repair With Fiberglass Paste

Fiberglass paste is used for repairing small dents, scratches, and pits. Paste is made by mixing resin, hardener and fiberglass strand or filler to the consistency of putty. Where necessary, sand paint away around damaged area. On underside of coach, scrape away undercoating from damaged area, and wipe clean with solvent.

Preheat the area to be repaired using heat lamps. Mix desired quantities of resin and hardener according to manufacturer's instructions. Add powdered fiberglass strand into mixture to thicken it into a putty state.

**Note:** *If repair is made on a vertical surface, adding powdered filler material to mixture will reduce tendency of hot resin to flow or run.*

Apply the material with a putty knife or similar object, building material up to the desired contour. For deep filling and on vertical surfaces, several layers of material may be used.

A hacksaw blade, held flat to adjacent contour and then moved in a sawing action across the repair when the resin is in a gel state, will remove excess resin from repair. Finish repair with the same procedure as when using fiberglass cloth.

### 4.3 Typical Fiberglass Repair Procedure

Remove all loose particles or damaged material using a power sander or rasp. Clean area, overlapping hole approximately 1" to 1-1/2" (25-40 mm) all around. Remove all dirt, grease and paint

from area to ensure good bonding surface. Feather the cleaned area all around. See figure 3.

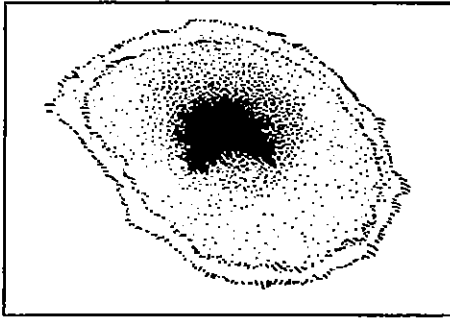

Figure 3 18089

Cut a piece of fiberglass mat slightly larger than area being repaired. Impregnate mat with general purpose polyester resin catalyzed normally. Use a clean paint brush to apply the polyester resin. Apply impregnated mat over hole and press onto surface with brush to obtain good adherence. Another coat of general purpose polyester resin can be applied at this time. See figure 4.

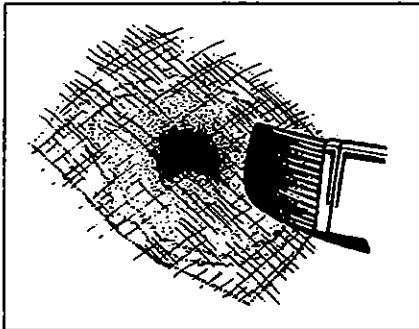

Figure 4 18090

**Note:** Remove all air between surfaces being joined. Allow area to harden and sand surface to remove any wax.

Apply another mat, followed by a cloth patch, and another mat. All layers must be thoroughly impregnated with polyester resin, brushed well and free of air. Apply more layers of mat and cloth as required until the desired strength and thickness is obtained, minimum two 1-1/2 oz (43 g) mats and one 9 oz (255 g) cloth. See figure 5.

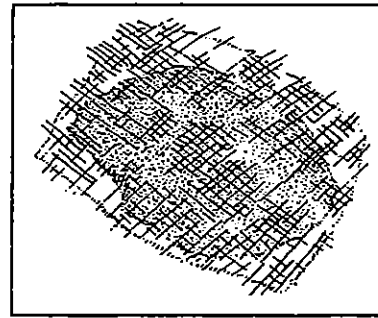

Figure 5 18091

Allow area to harden and contour the area with coarse sandpaper #100. See figure 6.

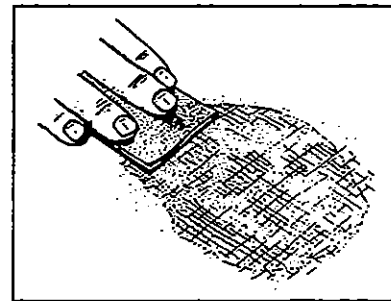

Figure 6 18092

Cover the area with a layer of resin putty and allow to dry for approximately 15 to 20 minutes. See figure 7.

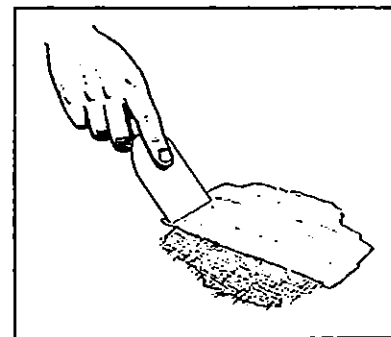

Figure 7 18093

Smooth off surface with coarse sandpaper #100 to desired shape. Further smooth surface with fine sandpaper #120 until repaired surface matches surrounding area panelling. Prime and paint the area to match surrounding paintwork.

## 5. PAINTING

The standard paint used on the exterior of the vehicle is Deltron PPG. It is a high gloss polyurethane enamel finish designed for exposure to extreme conditions.

### 5.1 Safety

Care should be exercised in storing, handling, mixing, and applying paint and chemicals listed in this manual. The topcoat, primer, solvent, catalysts, accelerators, and cleaners are highly volatile and/or toxic if not properly used. Observe all safety instructions marked on the different packagings, as well as the following:

1. Do not smoke in the paint room or in adjacent area exposed to residue fumes.
2. Wear respirators approved by the governing safety and health regulations.
3. Maintain adequate ventilation at all times.
4. Dispose of any leftover paint mix properly.
5. Wear rubber gloves, rubber apron, and face shield during all phases of paint and chemical handling.

### 5.2 Surface Preparation

#### 5.2.1 Aluminum Surface

Sand large surfaces with P150 grit sandpaper and other surfaces with "Scotch-Brite" or similar abrasive pad.

#### 5.2.2 Fiberglass Surface

Sand large surfaces with P180 grit sandpaper and other surfaces with "Scotch-Brite" or similar abrasive pad.

#### 5.2.3 Washing

1. With an air pressure jet, clean the surface from top to bottom and from front to back.
2. Clean the entire surface with a tag rag.
3. Wash the entire surface with a mix of thinner (2 parts) and isopropyl alcohol (1 part). Wash small zones and wipe before the surface dries by itself.

### 5.3 Primer Application

**Warning:** Always prepare primer in well ventilated area.

#### 5.3.1 Aluminum Surface

1. Stir primer for two minutes.
2. Mix: 1 part PPG epoxy primer DP-40 (Prévost part no 68-1078).  
1 part PPG epoxy activator DP-401 (Prévost part no 68-1079).
3. Wait 30 minutes before application.
4. Adjust gun pressure to 45 psi (310 kPa).
5. Spray a wet coat uniformly while holding gun at 8" (20 cm) and perpendicular to the surface.
6. Allow 1 hour to dry, and not more than a week before painting.

#### 5.3.2 Fiberglass Surface

1. Stir primer during 2 minutes.
2. Mix: 5 parts PPG high solid primer K-36 (Prévost part no 68-1927).  
1 part PPG activator K-201 (Prévost part no 68-1928).  
1 part PPG thinner DT-895 (Prévost part no 68-1926).
3. Adjust gun pressure to 45 psi (310 kPa).
4. Spray a wet coat uniformly while holding gun at 8" (20 cm) and perpendicular to the surface.
5. Allow 1 to 2 hour to dry.

### 5.4 Painting

Sand the entire surface with P320 grit sandpaper. Wash the surface in accordance with the washing procedure described in the surface preparation section.

#### 5.4.1 PPG Paint Application

1. Clean the entire surface with a tag rag.
2. Using a paint gun, apply PPG anti-static DX-103 (Prévost part no 68-2003) while holding the gun at 12" to 15" (30 to 38 cm) from the surface.



3. Mix: 1 part PPG base color DBU.  
1 3/4 parts PPG reactive thinner DRR-1185 (681931).
4. Adjust gun pressure to 45 psi (310 kPa) for solid color or to 55 psi (380 kPa) for metallic color.
5. Spray color uniformly while holding gun 8" to 12" (20 to 30 cm) and perpendicular to the surface. Repeat until you have a good color coverage (3 to 5 coats). Wait 5 to 10 minutes between each coat.
6. Allow 1 hour to dry.

#### 5.4.2 PPG Clear Application

1. Wash the surface with rags and a solution of water (3 parts) and isopropyl alcohol (2 parts).
2. Apply PPG anti-static DX-103 (Prévost part no 68-2003) while holding the gun at 12" to 15" (30 to 38 cm) from the surface.
3. Clean entire surface with a tag rag.
4. Mix: 2 parts PPG clear DCU-2001 (Prévost part no 68-1929).  
1 part PPG thinner DT-885 (Prévost part no 68-1925).  
1 part PPG activator DU-6 (Prévost part no 68-1930).
5. Adjust gun pressure to 55 psi (380 kPa).
6. Spray a coat uniformly while holding the gun at 8" (20 cm) and perpendicular to the surface. Wait 5 to 10 minutes and spray a second clear coat.
7. Allow 16 hours to dry.

## 6. COACH FRONT AND REAR BUMPERS

### 6.1 Repair of Superficial Damage

This procedure defines a method of repairing bumper surface damages such as superficial scratches or scuffing which are unacceptable in appearance only. For substantial bumper damages such as cracks, tears or holes, refer to

heading "Repair of substantial damages" in this section.

1. Inspect the damaged area as follows:
  - a) If a rough edge of paint is apparent immediately surrounding the scratch or scrape, lightly wipe the local area with a tack cloth or very fine steel wool, "000" maximum. This should remove residual flakes or paint build-up.
  - b) If grease and/or oil contaminants are apparent close to the damaged areas, wipe the surface with any commercially available grease remover.

**Caution: Do not use silicone-based materials to remove contaminants.**

2. Locally wipe the damaged area with mineral spirits or the equivalent, ensuring that any grease remover from step 1(b) is covered. Allow sufficient time for all solvents to vaporize prior to painting (5 to 10 minutes).
3. Apply the recommended repair paint, either aerosol or air spray gun, to the damaged area. The can or spray gun should be kept at a distance of 6 to 10" (150 to 250 mm) from the surface to be covered, with continuous side-to-side motion, sweeping across the damaged area. To ensure a good blend with existing paint, the sweeping motion should begin and end to the side of the area to be covered. Larger areas to be covered will require the back-and-forth sweeping motion to be gradually moved up and/or down, as shown in figure 8.



Figure 8

18094

**Note: Except for H3-45 VIP body-colored bumpers, the recommended repair paint is Tempo Color Spray #411 (black).**

## Section 18: BODY

4. Allow a minimum of 10 to 15 minutes for the paint to dry, 5 minutes for parts which are heated at the time of painting.

### 6.2 Repair of Substantial Damage

**Note:** *The following material can be purchased locally:*

- Three kits of 3M #8101 Structural Adhesive, Components A and B
  - Applicators
  - 3M Auto Body Repair Tape #06935
  - Grinder or sanding block with #36 disc or coarse sandpaper
  - 220, 320 and 400 grit sandpaper.
  - Any generally acceptable oil or grease remover.
1. Wipe the damaged area with solvent to ensure a clean surface.
  2. Remove enough surface material using a grinder or rough sanding block to ensure maximum adhesion of repair material.
  3. Bevel the front edges of the crack or hole.
  4. Featheredge the paint around the abraded area.
  5. Clean the repair area with a soft, dry cloth or air gun.
  6. Wipe the back side of the repair area with solvent for maximum strength and apply auto body repair tape. Make sure that the edges of the damaged area meet evenly.
  7. Mix A and B components of the 3M Structural Adhesive #8101 according to directions.

**Note:** *To prevent air bubbles during mixing, the components should be scraped together with downward pressure and spread thinly on the mixing board. Adhesive should be used within 2 minutes. Observe safety precautions.*

8. Apply a thin layer of adhesive to the damaged area with an applicator. Allow it to stiffen (approximately 15 minutes). Mix additional adhesive and apply to restore the contour.

**Note:** *In restoring the contour, spread the edges toward the center, filling all low areas. If voids, bubbles, or low areas occur, mix more adhesive and apply.*

9. Allow a 24-hour room temperature cure for optimal results before sanding. If a faster cure is necessary, application of heat by heat lamp or hot air gun may be utilized.

**Note:** *If heat is applied, maintain the temperature between 150 and 200 °F (65-90 °C) for 20 to 30 minutes.*

10. Grind or block-sand the repair area to the correct contour. Grind with a #220 disc, followed by 320 sandpaper, followed by 400 wet-or-dry.
11. Redo contour on any low spots with additional adhesive.
12. Clean off the repaired area and refinish the part according to the instructions under the heading "Refinishing Procedure" in this section.

### 6.3 Refinishing Procedure

Bumpers that are factory painted have a flexible, very tough, abrasion and weather resistant, elastomeric enamel coating that has been baked on at approximately 250 °F (120 °C). There may be collisions or accidents in which the paint is marred to such an extent that refinishing is desirable. When paint baking facilities are not available, air-dry repair systems, such as those used in soft fascia passenger car body repair, are suggested.

Excellent results from the standpoint of flexibility, adhesion to surface material, and gloss may be obtained with two-component urethane enamels. These systems consist of a reactive enamel and an activator.

**Note:** *If needed, a reducer may be added. DuPont's Imron is widely used.*

Two-component systems generally do not have as high a degree of flexibility as the one-component urethane enamels, but are designed for applications where high temperature baking is not feasible.

Less desirable, but often providing an excellent finish, are the flexibilized acrylic lacquers. These lacquer systems are composed of a base lacquer, a solvent, and an elastomeric additive. PPG's Ditzler is widely used, as well as systems from DuPont and Sherwin Williams. These are readily

available at body repair shops and automotive parts dealers.

### 6.3.1 Surface Preparation

Surface preparation is the most important step in repainting. Water soluble dirt should be removed first, followed by a thorough cleaning with a wax and grease removing solvent. Bumpers that have been punctured, cut, or gouged should be repaired according to instructions for the 3M adhesive under the heading "Repair of Substantial Damages" in this section. The patch should be sanded to the level of the surrounding bumper surface.

Painted surfaces, as well as exposed surfaces, should be sanded with a fine grit (400) sandpaper until the enamel finish is dulled. The entire face should be sanded since it is difficult to match colors in spot refinishing. Sanded surfaces should again be cleaned with a good wax and grease removing solvent to ensure good wetting of the surface and to prevent "fish eyes" formation.

### 6.3.2 Prime Coat

Most lacquer manufacturers recommend a separate primer coat before applying the color coat to produce maximum adhesion. Check specific directions on the manufacturer's label.

### 6.3.3 Color Coat

In applying final coatings, several wet coats should be sprayed with flash time between coats depending on hiding power and color match. Application information, as well as air-dry time, should be specified on the product container. Repairs should be allowed to dry overnight before putting bumper in service.

**Warning:** Proper precautions must be taken when applying air-dry elastomeric paints. Refer to manufacturer's warnings for details.

## 6.4 Front Bumper Removal and Installation

The front bumper is hinged to give access to the spare wheel and tire compartment. Bumper must first be tilted down before its removal. Two

persons are required to remove and install the front bumper.

**Warning:** Front bumper weighs approximately 220 lbs (100 kg). Use proper lifting equipment to support the bumper during the removal and installation operations to avoid personal injury.

1. Loosen 2 nuts on binding rods from under the bumper while holding the bumper closed. See figure 9.

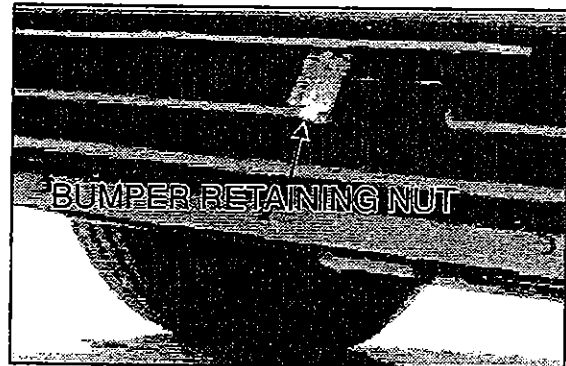

Figure 9

18057

2. Hold bumper and push binding rods up to remove the 2 binding rod hooks from their respective attaching points. See figure 10.

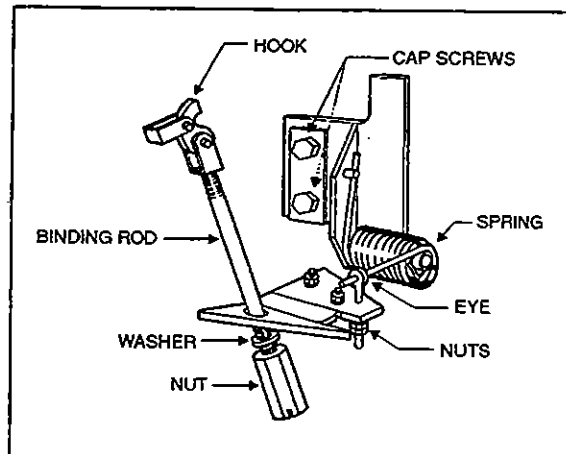

Figure 10

18095

3. Partly recline the bumper, remove both chain end snap hooks from their attaching points, and let the bumper rest face down on the lifting equipment platform.
4. Ask assistant to relieve spring tension on one eye bolt with proper tool. Remove 2 nuts and

eye bolt holding spring and slowly release spring. Repeat procedure for the other eye bolt.

**Note:** A convenient tool to relieve spring tension can be fabricated with 2 lengths of square tubing approximately 30" (75 cm) long, welded together, and fitted at one end with a cut-out adapter to hold the spring. See figure 11.

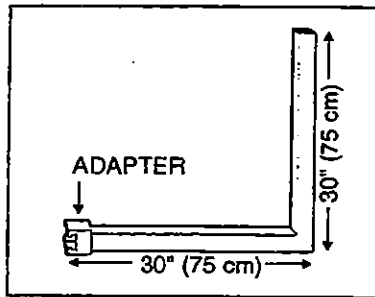

Figure 11 18096

5. Remove 4 cap screws holding bumper to vehicle and remove bumper.
6. To install bumper, reverse the removal procedure.

**Caution:** Check that binding rod hooks are properly anchored when bumper is tilted up before tightening binding rod nuts. Tighten binding rod nuts firmly.

## 6.5 Rear Bumper Removal and Installation

1. Remove 4 cap screws and washers retaining the rear bumper top panel and remove panel.
2. Remove 6 cap screws and washers holding bumper to engine frame, 3 at each end, under the bumper.
3. Remove 6 cap screws and washers holding bumper to engine frame, 3 at each end, above the bumper and remove bumper.
4. To install bumper, reverse the removal procedure.

## 7. COACH ENTRANCE DOOR

### 7.1 Operation

The coach sedan-type entrance door is driven by a hydraulic cylinder. Door activation is controlled by a relay panel, located near defroster-wiper motor. This module is supplied through circuit breaker #CB-85 (6 amps). The opening and closing valves transfer the air to the double acting hydro-pneumatic master cylinder located under the stepwell in the spare wheel compartment. The master cylinder drives the door cylinder and the accessory air reservoir supplies this system.

The door is controlled by a rocker switch mounted on the R.H. dashboard and by a toggle switch located behind the front door switch access panel. Refer to the pneumatic diagram (figure 17) and to the page 22 of the wiring diagram for the understanding of the system.

#### 7.1.1 Emergency Exit Valves

From inside the vehicle, an emergency exit valve, located on R.H. side of the driver's HVAC unit access panel, releases the pressure from the lock cylinders. From the exterior, an emergency exit valve in the front service compartment, also releases the air from the lock cylinders. If the door has been locked with the key, a lever on the door can be moved to unlock.

#### 7.1.2 Without Air and With or Without Electricity

If the air pressure drops while with or without electricity, the spring loaded cylinders will unlatch the door. In such a case, unlock the door by moving the lever on the door or by using the key, then open the door manually.

#### 7.1.3 With Air and Without Electricity

From inside the vehicle, turn the emergency exit valve to the "UNLOCK" position. Move the lever. From the exterior, turn the emergency exit valve to the "UNLOCK" position. Open the door. Close it, lock with the key and reset the outside emergency exit valve to the "NORMAL" position.

## 7.2 Adjustment and Maintenance

The horizontal and vertical positioning and the door depth in its frame are adjustable. The stroke of the door cylinder and the door opening speed are not adjustable. The speed is controlled by a locked pressure regulator.

### 7.2.1 Horizontal and Vertical Adjustments

1. Remove the screws and the plastic moulding covering each of the hinges.

**Note:** Ask an assistant to help you to perform the following adjustments.

2. Remove the Allen button head screw and the washer retaining the rod end with bearing to the upper hinge. See figure 12.

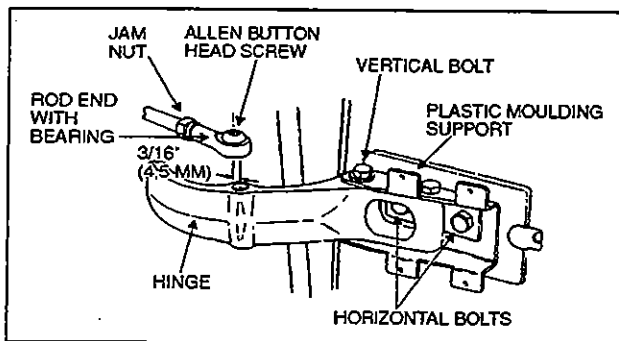

Figure 12

18058

3. Support the door with a wooden block and a hydraulic jack.
4. Loosen the horizontal bolts retaining the door to the hinges, adjust the door horizontally and vertically with the jack, tighten the bolts to 30-36 lbf·ft (40-50 N·m). Remove the jack and the wooden bloc.

**Caution:** Make sure the front side door does not interfere with the exterior panel.

5. Pull and fix the rod end to the hinge with the washer and the button screw.
6. Using the screws, fix the plastic mouldings covering the hinges.

### 7.2.2 Depth Adjustment

1. Turn the emergency exit valve to the "UNLOCK" position.
2. Remove the screws and the plastic moulding covering each of the hinges.

**Note:** Ask an assistant to help you to perform the following adjustments.

3. Remove the Allen button head screw and the washer retaining the rod end with bearing to the upper hinge. See figure 12.
4. Loosen the vertical bolts on the hinges for the front section, and for the rear section, move the central door catch on the door frame.
5. To adjust the male dovetail on L.H. side of the door, remove the two screws and loosen the two bolts. Slide the male dovetail toward the interior and lightly tighten the two bolts. Close the door slowly but firmly, then slowly open it, and tighten the two bolts. Fix dovetail to the door with the screws. See figure 13.

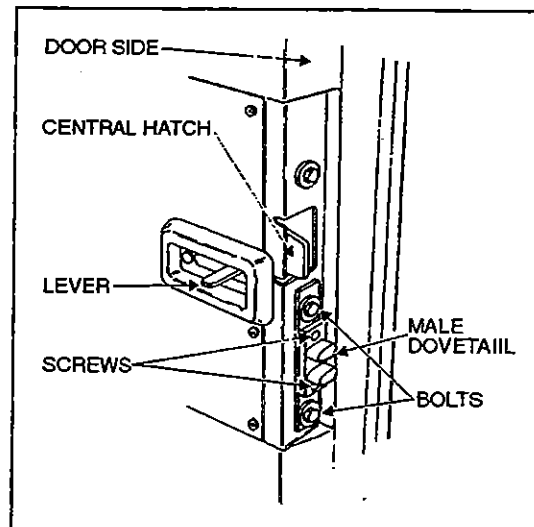

Figure 13

18059

**Note:** The frame dovetail is not adjustable.

6. Pull and fix the rod end to the hinge with the washer and the button screw.
7. Using the screws, fix the plastic mouldings covering the hinges.
8. Reset the emergency exit valve to the normal position.

### 7.2.3 Rod End With Bearing Adjustment

1. Turn the emergency exit valve to the "UNLOCK" position.
2. Remove the screws and the plastic mouldings covering the upper and lower hinges.
3. Remove the Allen button head screw and the washer retaining the rod end with bearing to upper hinge. See figure 12.
4. Loosen the jam nut locking the door cylinder rod end with bearing. Close the door firmly, adjust the rod end with bearing center hole in order to be 3/16" (4,5 mm) eccentric toward the left with the hinge hole center. Tighten the jam nut.
5. Pull and fix the rod end to the hinge with the washer and the button screw.
6. Using the screws, fix the plastic mouldings covering the hinges.
7. Reset the emergency exit valve to the normal position.

### 7.2.4 Lubrication

	Lubricant	Frequency
<ul style="list-style-type: none"> <li>• Latches</li> <li>• Upper door catch</li> </ul>	Low temperature grease	Every six months
<ul style="list-style-type: none"> <li>• Door locking mechanism</li> </ul>	White grease	Every six months
<ul style="list-style-type: none"> <li>• Key hole</li> <li>• Bearing of rod end</li> <li>• Hinges</li> </ul>	Low viscosity oil	Every six months

## 7.3 Hydraulic System

The hydraulic system uses a solution of 50% of antifreeze ethylene glycol base and 50% of water. The system contains approximately 1.1 U.S. quart (1 liter).

### 7.3.1 Filling

**Note:** Ask an assistant to help you perform this procedure.

1. Insert a 3/16" (5 mm) I.D. hose on each drain cock of the door cylinder and on the liquid side of the master-cylinder, then submerge the hose ends in a clear glass container partially filled with a clean antifreeze solution.
2. Open the two door cylinder drain cocks.
3. Open the door and with an adhesive tape, maintain the door switch to the "ON" position to maintain the system under pressure.
4. Close the door manually, or push cylinder in, then the hydro-pneumatic system should be as shown in figure 14.
5. Fill the master cylinder with a low pressure pump (less than 75 psi (515 kPa)), through the filling cock. See figure 14.

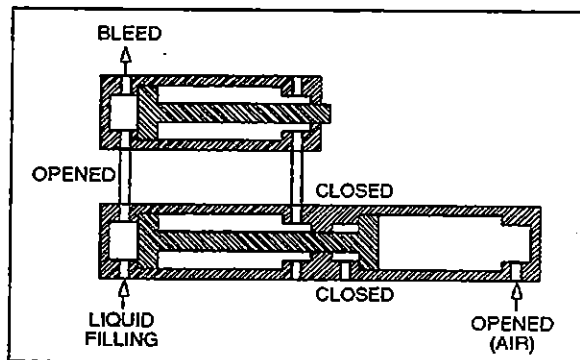

Figure 14

18097

6. Close the L.H. door cylinder drain cock immediately when the liquid flows into the container, then pump until the door be fully opened, without pressurising the system. See figure 15.
7. Close the L.H. cock on the master cylinder. See figure 15.

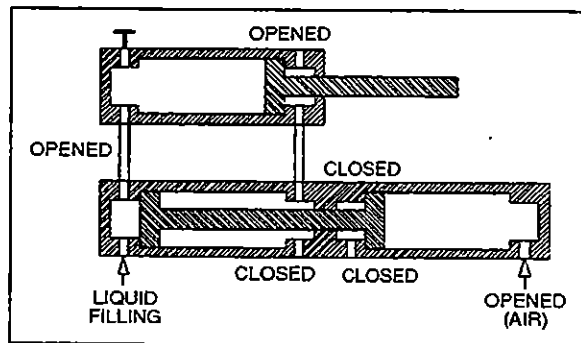

Figure 15

18087

8. Remove the adhesive tape and close the door by pushing the switch.
9. Open the drain cock on the door cylinder and the filling cock on the master cylinder piston side. See figure 16.

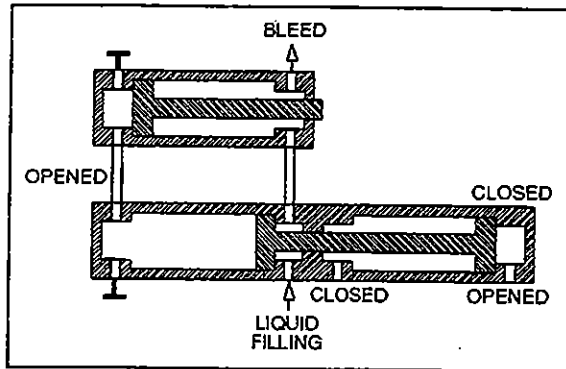

Figure 16

18088

10. Pump the liquid on the system until it flows into the container.
11. While you are pumping, slowly open the door in order to fill the master cylinder while exhausting the air from the cylinder.
12. Once the door is fully opened, close all cocks, and remove the pump.
13. Bleed the system. Refer to the bleeding procedure.

### 7.3.2 Bleeding

Bleed cycles must be performed after each filling or when the system leaks.

### 7.3.3 Piston Side Bleeding

1. Open and close the entrance door to bring air to the door cylinder.
2. Insert a 3/16" (5 mm) I.D. hose on the door cylinder L.H. drain cock.
3. With the door closed, slowly open the L.H. drain cock on the door cylinder, while pressurizing with the pump on the master cylinder through the L.H. cock, then close the door cylinder cock.
4. Repeat steps 1 and 3 until there is no more air in the cylinder.
5. Remove the pump and the hose.

### 7.3.4 Cylinder Side Bleeding

1. Open and close the entrance door to bring air to the door cylinder, then fully open the door.
2. Insert a 3/16" (5 mm) I.D. hose on the door cylinder R.H. drain cock.
3. With the door open, slowly open the R.H. drain cock on the door cylinder, while pressurizing with the pump on the master cylinder through the R.H. cock, then close the door cylinder cock.
4. Repeat steps 1 and 3 until there is no more air in the system.
5. Remove the pump and the hose.

**Note:** *Dispose of antifreeze in accordance with the effective municipal, provincial and federal regulations.*

## 7.4 Specifications

### Master cylinder

Manufacturer .....Bimba  
 Type .....Hydro-pneumatic, 1/4 NPT  
 I.D. .... 2" (50 mm)  
 Stroke ..... 9" (230 mm)  
 Prévost number.....78-0498

### Door cylinder

Manufacturer .....Bimba  
 Type .....Hydraulic, double acting, 1/4 NPT  
 I.D. .... 2" (50 mm)  
 Stroke ..... 8" (205 mm)  
 Prévost number.....78-0499

### Lock cylinder (upper)

Manufacturer .....Bimba  
 Type ....Air, single action, 1/8 NPT, hexagonal rod  
 I.D. .... 7/8" (22 mm)  
 Stroke ..... 1" (25 mm)  
 Prévost number.....64-1259

### Lock cylinder (central)

Manufacturer .....Bimba  
 Type .....Air, single action, 1/4 NPT  
 I.D. .... 1 3/4" (45 mm)  
 Stroke ..... 1" (25 mm)  
 Prévost number.....64-1209

**Section 18: BODY**

**Manifold solenoid**

Manufacturer ..... Norgren  
 Type ..... 4 ports, 1/8 NPT  
 Voltage ..... 24 VDC  
 Power consumption ..... 6 watts  
 Maximum pressure ..... 150 psi (1 035 kPa)  
 Prévost number ..... 64-1130

**Solenoid valve (Latching valve)**

Manufacturer ..... Humphrey  
 Model ..... 310  
 Operating range ..... 0 to 125 psi (0 to 860 kPa)  
 Voltage ..... 24 VDC  
 Voltage tolerance ..... +10%, -15% of rated voltage  
 Power consumption ..... 4 watts  
 Leak rate (max allowed) .....  
 ..... 0.245 in<sup>3</sup>/min @ 100 psi (4 cc/ min @ 690 kPa)

Type of operation ..... Direct solenoid  
 Lubrication ..... Not required (factory pre-lubed)  
 Filtration ..... 40 micron recommended  
 Prévost number ..... 64-1217

**Pressure regulator**

Manufacturer ..... Norgren  
 Recommended pressure setting 100 psi (609 kPa)  
 Supplier number ..... R07-100-RNKA  
 Prévost number ..... 64-1219

**Pressure switch assy**

Prévost number ..... 45-2043  
 Electronic module Prévost number ..... 06-3926

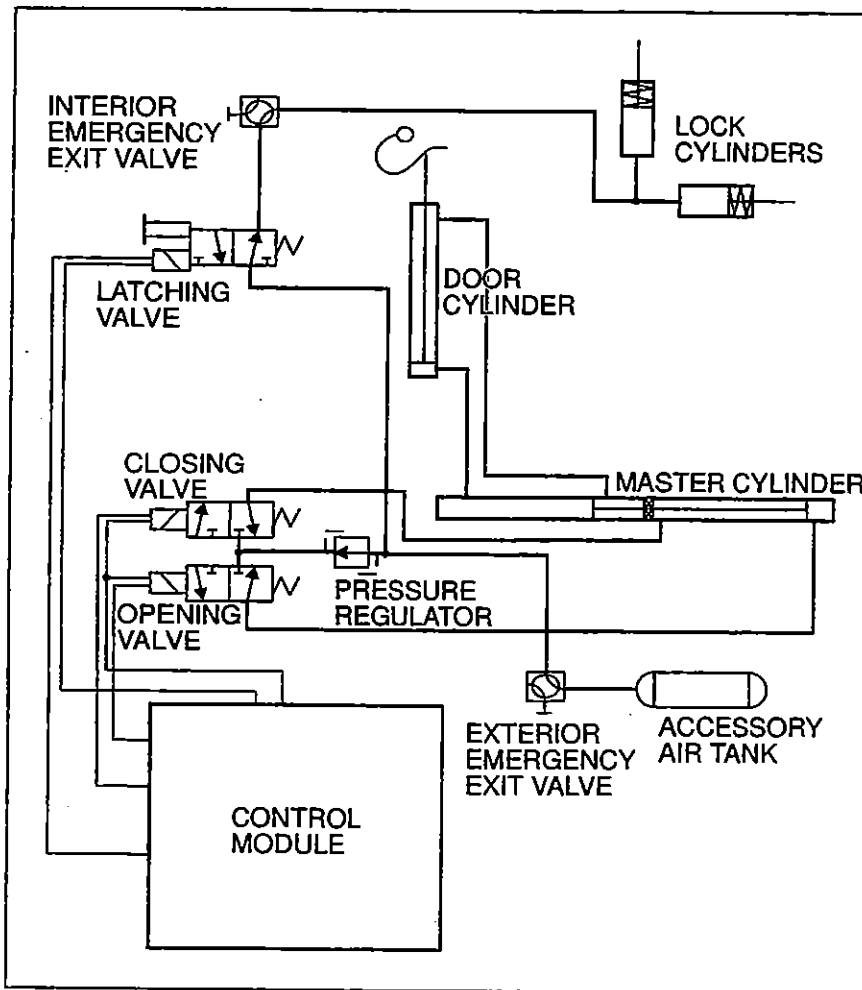

Figure 16

18060



## 8. BAGGAGE COMPARTMENT DOORS

There are 6 baggage compartment doors on the H3-41, while there are 8 on the H3-45 and the VIP H3-45 bus shell. Each of these doors is of identical design. A centrally mounted, key-lockable door handle unlatches the door which can then be pulled out and raised up in a path parallel to the side of the vehicle. The door is held in fully open position by two fully extended gas-charged cylinders, giving clear access to the opening of the baggage compartment.

From its fully open position, the door can be closed by pulling down on the door panel, which will easily hinge its way back in the contour of the compartment opening and will be held closed by two latches.

Each door can be opened by lifting the centrally mounted handle to unlatch the door and lifting it all the way up. If the door does not remain in the fully open position, one or both cylinders on that door is (are) defective. To test the cylinders, first support the door in the fully open position with proper equipment. Disconnect the rod end of one cylinder and try to retract the rod. If strong resistance is felt, the cylinder is in good condition and can be reinstalled. If the rod retracts with little effort, the cylinder is defective and should be replaced at once (Prévost part #98-0014). Test the other cylinder on that door the same way.

### 8.1 Adjustment

**Warning:** Park vehicle safely, apply parking brake, stop engine and set battery master switches to the "OFF" position prior to working on the vehicle.

**Note:** Refer, if needed, to figure 18 for identification of door components.

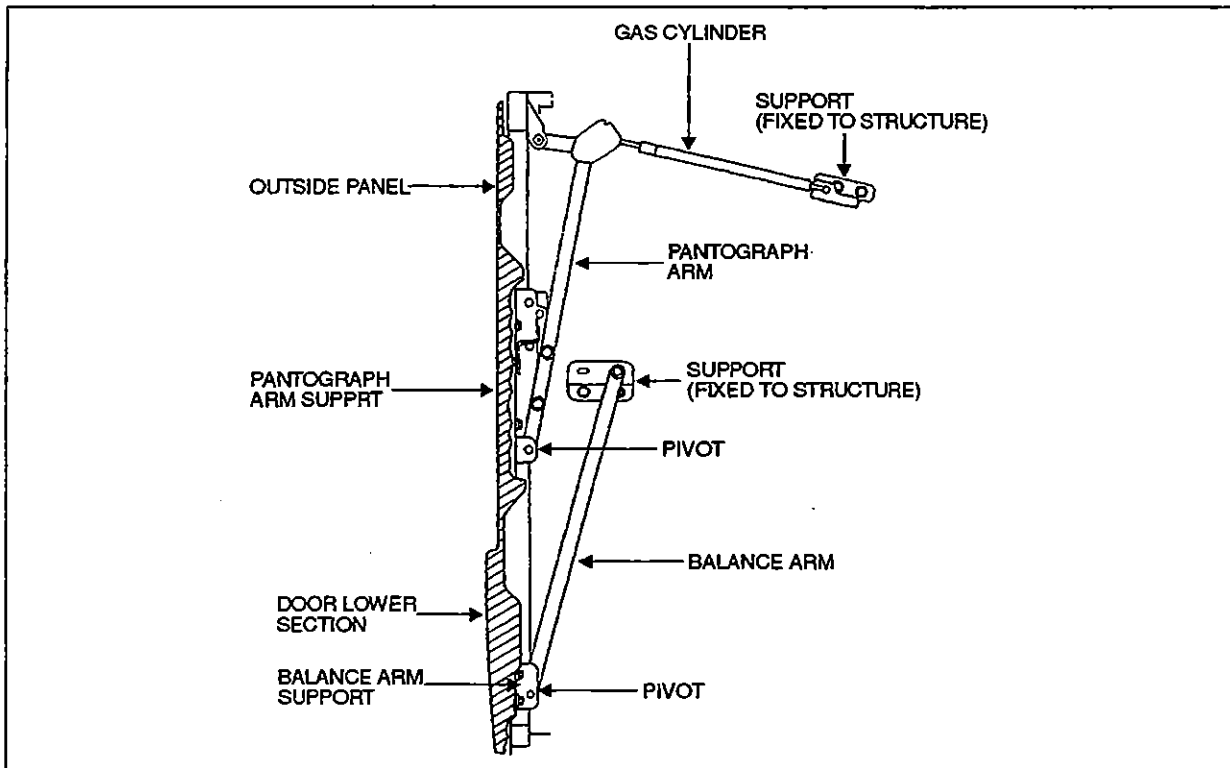

Figure 18

18061

**Section 18: BODY**

1. With the help of an assistant who will support the door weight, remove bolts retaining door to pantograph and balance arm pivots, then remove door.
2. Measure distance between a pantograph arm end and a straight edge rested on structure. Repeat procedure for the other arm. The distance on each side should be equal. If not, bend arm end until desired measure is obtained. Refer to figure 19.

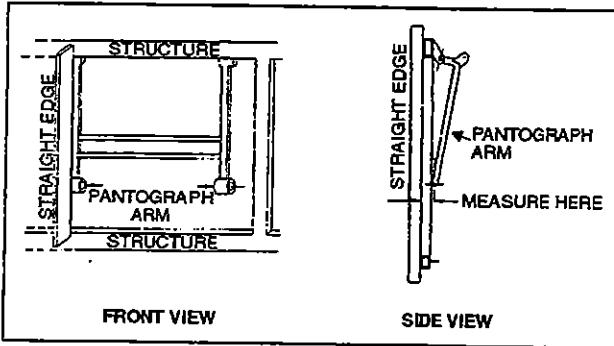

Figure 19

18062

3. Measure distance between a pantograph arm end and the structure. Repeat procedure for the other arm. The distance on each side should be equal as the pantograph arm assembly must be centered in baggage compartment opening. If not, bend the appropriate pantograph arm end until desired measure is obtained. A difference of  $3/32$ " (2 mm) between both sides is accepted. Refer to figure 20.

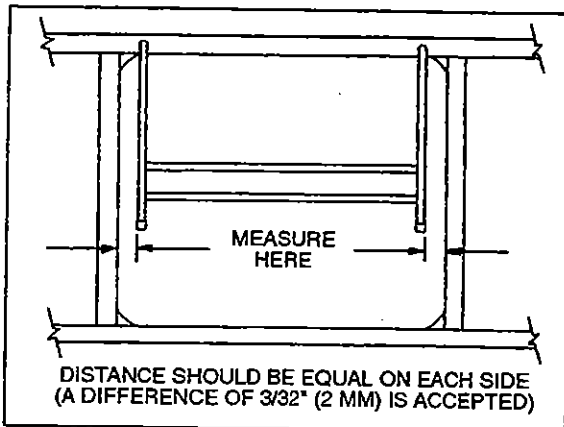

Figure 20

18063

4. Install the baggage compartment door. Unscrew and remove both striker pins.

Loosen bolts retaining door to pantograph and balance arm supports. With door closed, adjust height so the top of the door fits flush with the adjacent doors, then complete tightening the four bolts retaining door to each pantograph arm support. A gap of  $1/8$ " (3 mm) between the top of the door and the stainless steel support is given as a guide. Refer to figure 21.

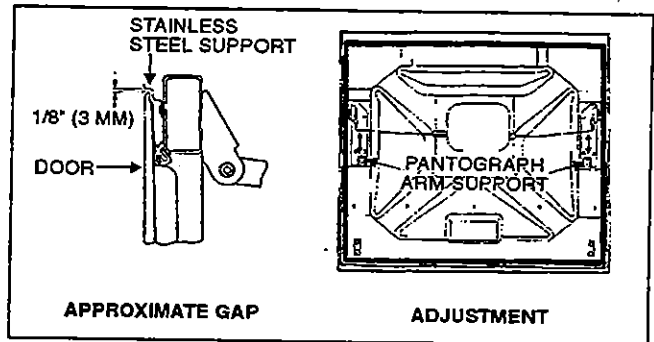

Figure 21

18064

5. Slightly open the door, position it to obtain a gap of 4" (100 mm) between structure and door panel upper lip, maintain door in this position while an assistant completes tightening the two bolts retaining door to each balance arm support. Refer to figure 22.

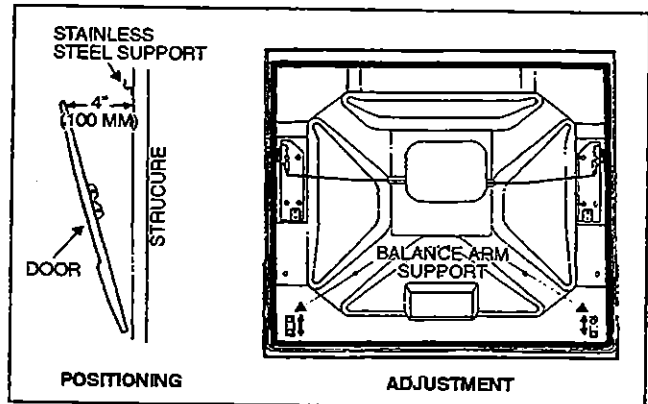

Figure 22

18065

6. Fully open the door, loosen the two bolts retaining each gas cylinder support to structure, position door parallel with adjacent doors and complete tightening bolts. A measure of  $6$ "  $\pm$   $1/4$ " (150 mm  $\pm$  7 mm) between door panel lip (at level of upper edge of lower section) and the lateral panel is given as a guide. Refer to figure 23.

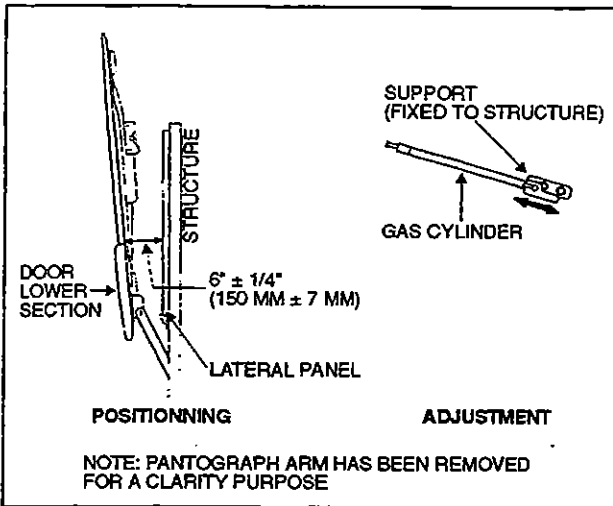

Figure 23

18066

**Caution:** For converted vehicles provided with "Awning" windows, fully open window then adjust door opening angle so the door does not interfere with window.

7. With door slightly open, pull door handle while an assistant checks that both latches release simultaneously. If not, with latch engaged, gently bend the appropriate latch control rod until proper timing is achieved. Refer to figure 24.

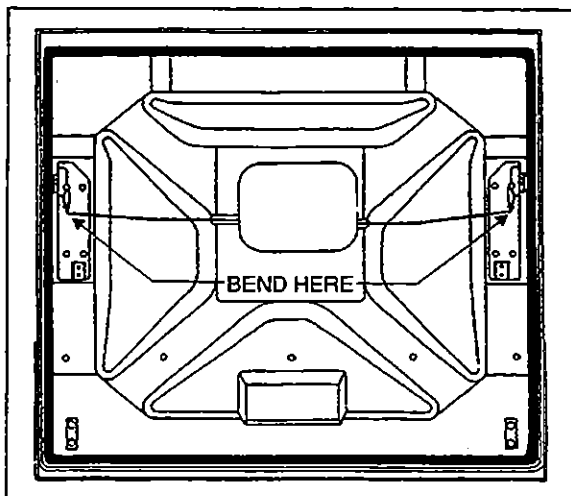

Figure 24

18067

8. Install both striker pins, bring the door close to them, and adjust the height of pins so they are well centered with latches. Refer to figure 25.

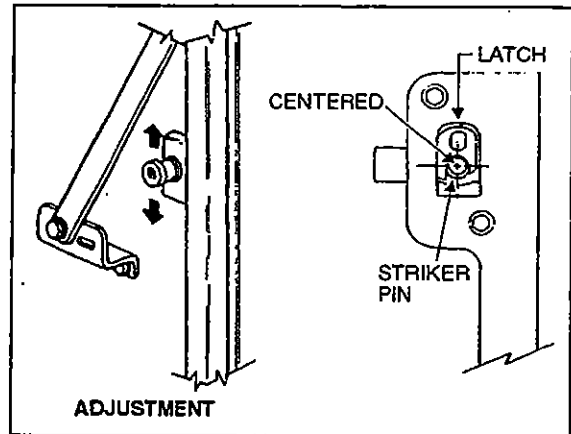

Figure 25

18068

**Note:** Before proceeding with the following step, mark the position of striker pins on structure to avoid upsetting the vertical adjustment of the pin.

9. Loosen the striker pins just enough to allow them to be moved with a hammer. Working from inside compartment and with the door well-closed (second catches engaged), hit the pin washers to horizontally move the pins and consequently the door, while an outside assistant checks the fit. A gap of 1/16" (+3/64", -1/64") (1,5 mm (+1 mm, -0,5 mm)) between the stainless steel support for the lateral panel and the door panel lip is recommended. Refer to figure 26.

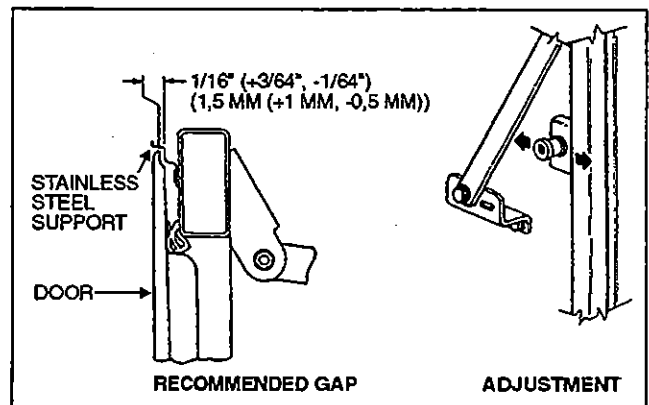

Figure 26

18069

10. With door well-closed, it should have a gap of 3/8" ± 5/64", (10 mm ± 2 mm) between door panel lip (at level of upper edge of lower section) and structural post. If not, horizontally move pins again until correct gap is obtained.

## Section 18: BODY

Fully tighten the pins after adjustment is achieved. Refer to figure 27.

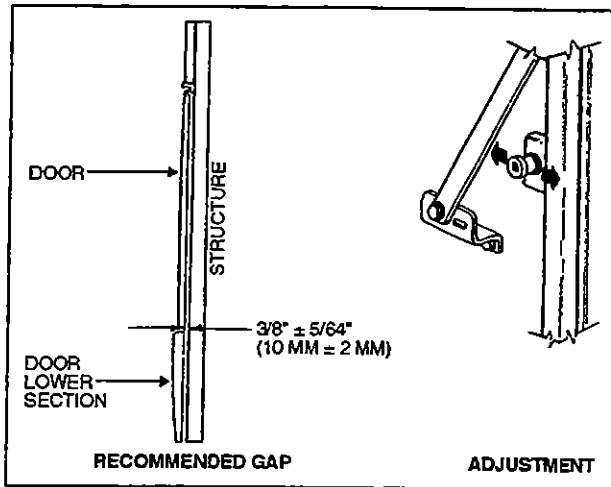

Figure 27

18070

11. Recheck gap mentioned in step 9. If gap has changed, correct half the change by adjusting arm support fixed to structure. Loosen the bolt supporting balance arm on door lower section and close the door, gap adjustment will automatically result. Tighten the bolt from inside the compartment. Refer to figure 28.

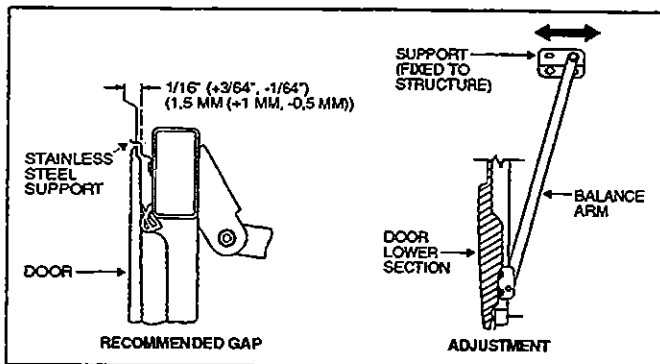

Figure 28

18071

12. Once the adjustment procedure is achieved, ensure that all bolts are securely tightened.

## 9. ENGINE COMPARTMENT DOOR

The engine compartment rear door also rises in the same way as the baggage compartment doors and is held open by 3 gas-charged cylinders

(Prévost part #98-0014). The engine compartment opens by lifting a handle accessed from the R.H. side of the engine compartment. When pushed up, the handle pulls on 2 steel wires, each steel wire connected to its respective door latch locking the rear door. Both steel wires are looped at the release handle and can be adjusted to proper length to ensure positive release of both catches when the handle is raised.

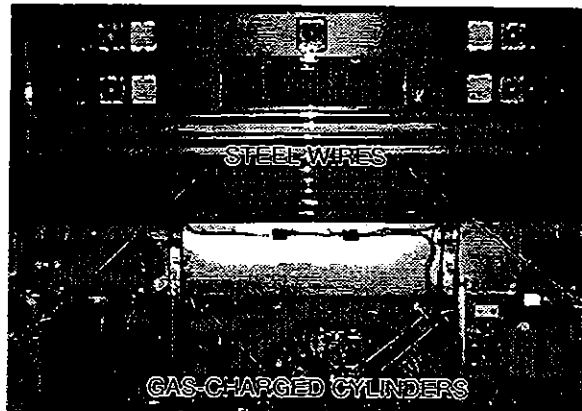

Figure 29

18072

## 10. COACH SIDE WINDOWS

Six passenger side windows are provided on each side of the coach on H3-41, while the H3-45 have seven on each side. They are made of fixed, single or double-glazed, heat absorbing AS-3 mounted in black painted extruded aluminum frames. The single-glazed windows are laminated safety glass, while the double-glazed windows are laminated safety glass outside and tempered glass inside. The two trapezoidal windows are also mounted on aluminum frames (except for H3-45 VIP, where they're mounted with adhesive, refer to heading "Adhesive mounted windows" later in this section, for more information on this type of mounting) and they are made of fixed, double glazed, heat absorbing AS-3 laminated safety glass inside and tempered glass outside. Three of the side windows on each side serve as emergency exits on the H3-41, while there are four of them on curb side of the H3-45, and three on driver's side. See figures 30 and 31.

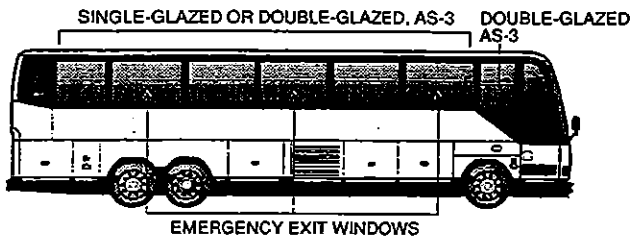

Figure 30: H3-41

18073

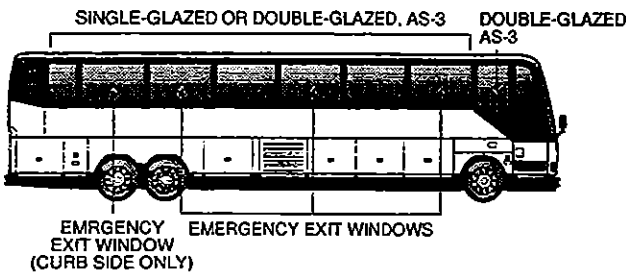

Figure 31: H3-45

18074

An emergency exit window can be opened by pulling the lower part of the release bar, which disengages the 2 safety latches, and pushing out the window frame. See figure 32.

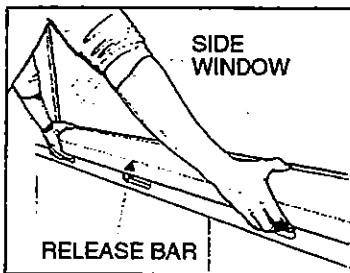

Figure 32

18075

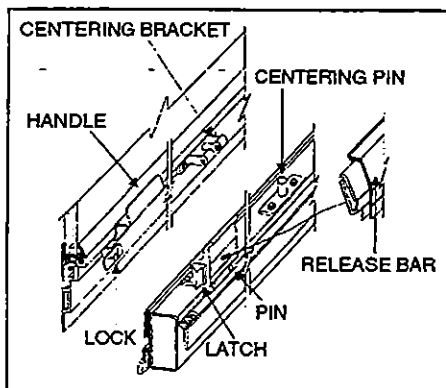

Figure 33

18076

Emergency operating instruction decals are affixed under each emergency exit window. To close the window, pull the 2 handles on the window frame to securely engage the safety latches in their respective locks. See figure 33.

## 10.1 Removal and Installation

The emergency exit windows can be removed from the vehicle with the help of an assistant. See figure 34.

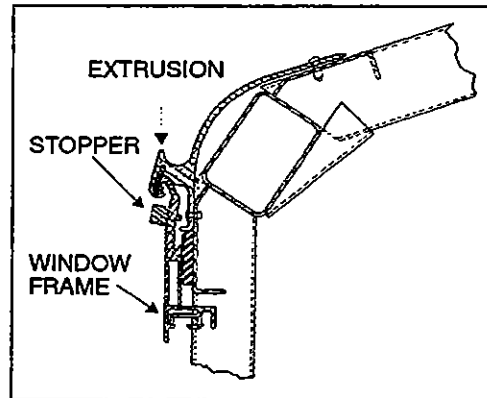

Figure 34

18077

1. Remove the 2 stoppers from the window frame outside the vehicle.
2. Unlock the window latches and swing the window out far enough to disengage the frame extrusions.
3. Lower the window assembly from the opening.
4. Installation of the window is the reverse of removal procedure.

The fixed side windows can be removed in the same way, after first removing 4 cap screws holding the bottom of the window frame to the inside wall of the vehicle. This will permit the window to swing out as an emergency exit window.

Spring pins are inserted in the roof aluminum extrusion on both sides of each window to prevent fore and aft movement of the window when opened. The spring pins do not have to be removed when removing and installing a window.

## 10.2 Emergency Exit Window Adjustment

Emergency exit windows should be checked periodically for easy opening and closing. Pulling the lower part of the release bar with both hands placed near the safety latches should disengage both locks on the window simultaneously. The tension required to release the window should not exceed 20 pounds (9 kg) of force. If too much effort is required to disengage the locks or if only one lock disengages when pulling the release bar, adjustment of the window locking mechanism must be made. Similarly, the window should close tightly and should not shake.

The centering pin and the centering bracket should be correctly positioned before performing the window locking mechanism adjustment. The window is correctly positioned in the opening when the centering pin aligns with the slot in the centering bracket. The 2 locks threaded in the window frame can be adjusted in or out for proper engagement in the safety latches. If the locks do not engage in the latches or require too much effort, they are threaded in too far. If the window rattles when closed, the locks extend too far out. To adjust the locks, first loosen the lock nuts and rotate the locks in or out in half-turn increments. Tighten the lock nuts when proper adjustment is made.

**Note:** *Tangs on the lock must be in a horizontal position.*

## 11. ADHESIVE MOUNTED WINDOWS

The adhesive mounted windows are fixed, single or double-glazed, heat absorbing AS-2 or AS-3 glass mounted in their opening with polyurethane windshield adhesive. The single-glazed windows are laminated safety glass, while the double-glazed windows are laminated safety glass outside, and tempered glass inside. The upper driver's windows can optionally be AS-4 Plexiglas. See figure 35 for location and type of sealed windows. To replace a damaged or broken adhesive mounted window, refer to heading "Replacement", next in this section.

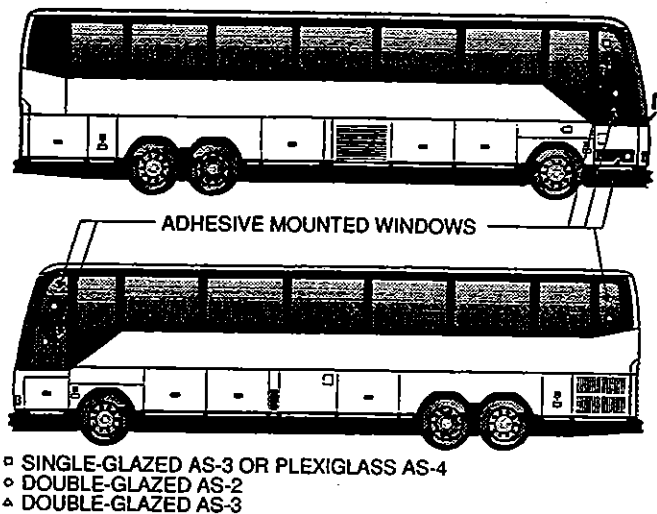

Figure 35

18078

## 11.1 Replacement

### Items Needed:

Scraper with new blade; Disposable vinyl gloves; Isopropyl alcohol or enamel reducer or NAPA 6383 surface cleaner; Masking tape; Clean rag; Heavy hydrotreated naphta (vanishing oil) (68-0102); Tremthane Primer (68-1091); Tremshield Tape (68-1089); Sikaflex 255FC (68-1092)

**Warning:** *Wear disposable vinyl gloves during the procedure. Do not smoke. Dispose of unused toxic material properly. Heed all warnings on containers of the different products.*

1. Remove previous window glass and scrape off all remaining material around the opening.

**Note:** *Hardened adhesive will not remove easily. A new blade works best to remove all adhesive residue using care not to damage the fiber structure.*

2. Place the new window glass in the opening and centre it to leave an even gap top and bottom, and from side to side.

**Note:** *Use small shims to raise the glass in proper position. Shims can be cut from the tremshield tape. See figure 36.*

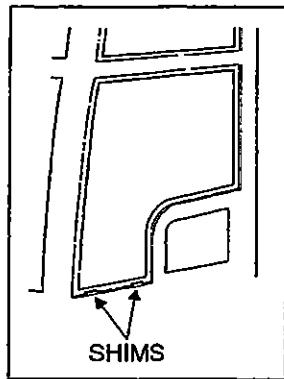

Figure 36 18079

3. Hold the window glass centered and have an assistant mark the inside contour of the opening on the glass with a china pencil. Remove glass and place it on a table with the pencil mark facing up.
4. Place masking tape on the inside surface of the glass to just cover the china pencil mark, leaving the outer surface exposed for the adhesive. This will make cleanup much easier. For ease of removal, do not overlap the tape at corners. See figure 37.

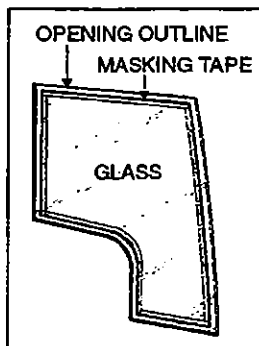

Figure 37 18080

5. Clean all around the window opening and the window glass edge with isopropyl alcohol, enamel reducer or NAPA 6383 surface cleaner. Let dry 1 to 2 minutes.

**Note:** There must be absolutely no silicone on glass or channel or Sikaflex 255 FC will not stick.

6. Put masking tape on the inner and outer contour of the window opening on the structure, approximately 1/16" (1,5 mm) from the edges of the contour.

7. Apply Tremthane primer (Prévost part no 68-1091) all around the window opening and the window glass edge.
8. Install Tremshield tape (Prévost part no 68-1089) around the sealing surface of the window opening. See figure 38.

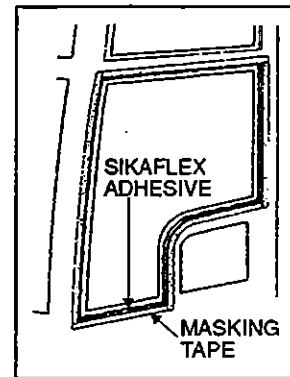

Figure 38 18081

9. Apply a generous bead of Sikaflex-255 FC polyurethane adhesive (68-1092) on the sealing surface around the window opening from outside the vehicle.

**Note:** To ease applying of Sikaflex 255 FC, it may be heated to 175°F (80°C).

**Note:** Bead should touch the side surface of the window opening.

10. Place shims correctly, and position window glass in the opening. Press firmly and evenly. Excess adhesive should flow out from behind glass.

**Note:** Add adhesive in areas where overflow is minimal or if air bubbles are present.

11. Smooth the adhesive joint using the plastic glove on your finger. Remove excess material around both sides of the window as soon as possible before adhesive dries.

**Note:** Remove most of the adhesive from the scraper or trowel with a rag, and then dip tool in heavy hydrotreated naphta (vanishing oil) after each use for cleaning.

**Caution:** Never use solvent to clean excess adhesive.

12. Remove masking tape at once, clamp window glass suitably and let dry overnight or at least 8 hours.

## 12. WINDSHIELD

The lower windshield is single-glazed, AS-1 laminated safety glass, while the upper windshield is single-glazed, AS-3 laminated safety glass. The upper windshield can be equipped, as optional equipment, with heating elements. Each windshield is laced to a flange around an opening in the front structure by means of a one-piece black rubber extrusion and sealed with Sika-flex-255 FC polyurethane adhesive (Prévost part no 68-1092). Proper installation of the windshield is necessary to ensure watertightness. Since glass varies in fit depending on the supplier, we recommend installing a replacement windshield obtained from Prévost Car Inc. to ensure proper fit. Windshield obtained from another source should be checked for proper size and curvature.

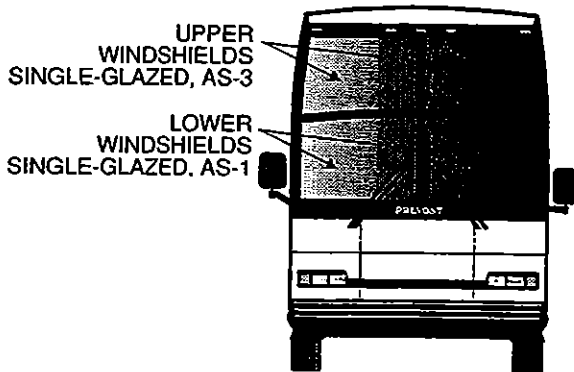

Figure 39

18082

### 12.1 Removal

**Warning:** Windshield removal and installation must be performed by more than one person. To avoid personal injury, wear protective gloves when handling the windshield glass.

1. Remove the wiper arms of the affected windshield.

**Note:** Remove the destination sign when replacing the upper R.H. side windshield.

2. Remove the rubber filler strip from the rubber extrusion around the windshield.
3. Run a blunt wood or plastic instrument inside channel of the rubber extrusion where the windshield is inserted, to loosen the windshield

from the extrusion, from inside and outside the vehicle all around the windshield.

4. Pry out the windshield starting at a corner and pushing the windshield out. A person on the outside then lifts the windshield up and out of the opening.
5. Clean the rubber extrusion channel with isopropyl alcohol. Refer to heading "Installation" in this section for instructions on how to reinstall windshield.

**Note:** If the rubber extrusion is damaged, remove and discard it, then clean the windshield opening with isopropyl alcohol. Refer to heading "Rubber Extrusion and Windshield Installation" in this section for complete reinstallation instructions.

### 12.2 Installation

**Warning:** Wear disposable vinyl gloves during the procedure. Do not smoke. Dispose of unused toxic material properly. Heed all warnings on containers of the different products used in this procedure.

1. Clean the rubber extrusion with wiping towels soaked with isopropyl alcohol. Wipe with dry wiping towels and let dry 1 to 2 minutes. See figure 40.

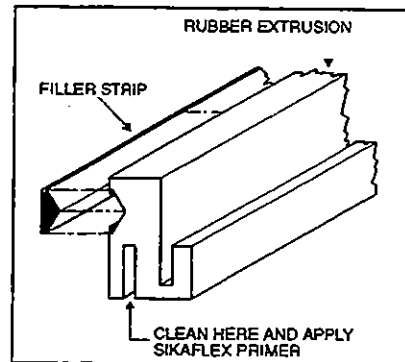

Figure 40

18098

**Note:** Force the soaked towels in the channels for good cleaning in these critical areas.

2. Apply Sikaflex primer 449/203 (Prévost part no 68-1091) with a paint brush or applicator in the channels around the rubber extrusion, and let dry 20 to 25 minutes while proceeding with the next steps.



**Caution:** If more than 8 hours elapse before proceeding with the installation, repeat step 3.

3. Spray the windshield channel of the rubber extrusion with a liquid soap and water solution.
4. Install the windshield in the rubber extrusion, bottom first, and working up the sides to the top using a thin and rounded wooden or plastic piece to force the windshield in its channel. End the installation at one of the upper corners.

**Note:** Two persons should be working on both faces of the windshield simultaneously.

5. Mask the windshield following the contour of the rubber extrusion. See figure 41.

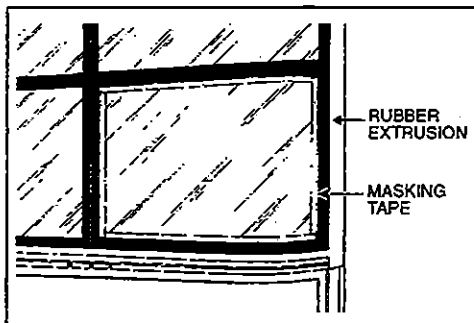

Figure 41

18099

6. Apply Sikaflex-255 FC polyurethane adhesive (Prévost part no 68-1092) generously between windshield and the rubber extrusion, while inserting the tip of the adhesive tube deep in the channel. Scrape excess adhesive from windshield and clean with Klene-Sol or equivalent solvent.
7. Spray V-channel in the rubber extrusion with a liquid soap and water solution, and install filler strips in the rubber extrusion, cutting each end at a 45° angle.

**Note:** Filler strips retract with time. Install ends of filler strips as tight as possible in the V-channel.

8. Remove all masking tape and clean all areas properly. Reinstall windshield wiper and destination sign if applicable.
9. Let dry overnight, or at least 8 hours, before putting vehicle back into service.

## 12.3 Rubber Extrusion and Windshield Installation

**Warning:** Wear disposable vinyl gloves during the procedure. Do not smoke. Dispose of unused toxic material properly. Heed all warnings on containers of the different products used in this procedure.

**Caution:** The black rubber extrusion securing the windshield in the opening fits correctly in only one position. Find the correct position of the rubber extrusion now, and make reference marks with a china marker to avoid searching for the correct position later in the procedure.

1. Clean the windshield opening sealing surfaces with isopropyl alcohol and let dry 1 to 2 minutes. See figure 42.

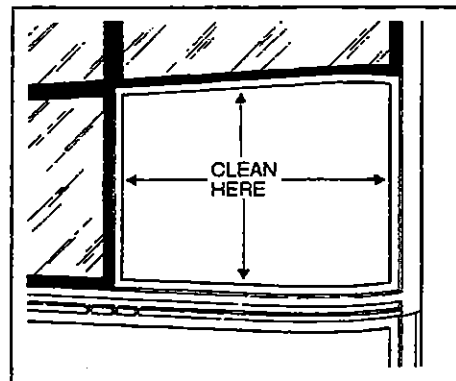

Figure 42

18100

2. Clean the rubber extrusion with wiping towels soaked with isopropyl alcohol. Wipe with dry wiping towels and let dry 1 to 2 minutes.

**Note:** Force the soaked towels in the channels for good cleaning in these critical areas.

3. Apply Sikaflex primer 449/203 (Prévost part no 68-1091) with a paint brush or applicator in the channels around the rubber extrusion, and let dry 20 to 25 minutes while proceeding with the next steps. See figure 43.

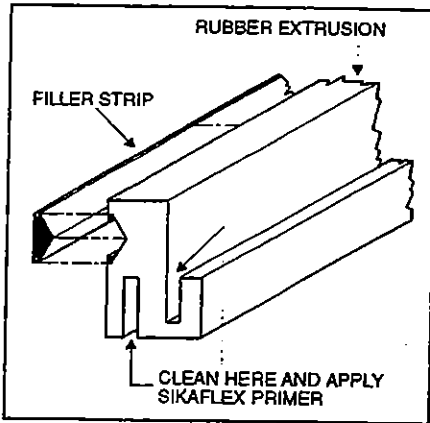

Figure 43

18101

**Caution:** If more than 8 hours elapse before proceeding with the installation, repeat step 3.

4. Mask the interior side of the windshield opening or apply a coat of petroleum jelly such as Vaseline to aid in removal of adhesive overflow after the installation.
5. Mask the exterior side of the windshield opening on the 2 sides not adjacent to the other windshield.
6. Apply 2 beads, parallel but not touching, of Sikaflex-255 FC polyurethane adhesive (Prévost part no 68-1092) on the sealing surface of the windshield opening. See figure 44.

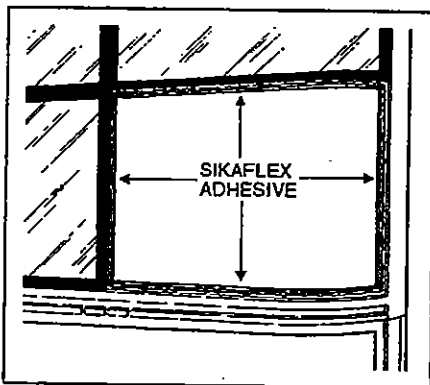

Figure 44

18102

7. Apply Sikaflex-255 FC adhesive all around the rubber extrusion in the channel for the windshield opening flange. See figure 45.

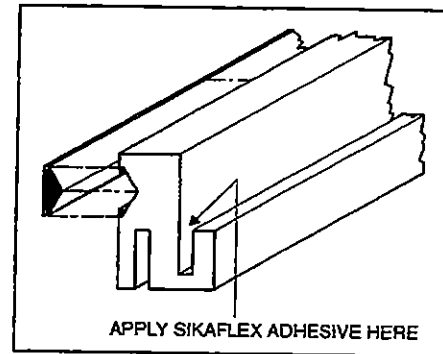

Figure 45

18103

**Caution:** Sikaflex adhesive hardens quickly. Continue installation immediately after application of adhesive is completed.

8. Find the reference marks made earlier and install the rubber extrusion in the windshield opening.
9. Spray the windshield channel of the rubber extrusion with a liquid soap and water solution.
10. Install the windshield in the rubber extrusion, bottom first and working up the sides to the top, using a thin and rounded wooden or plastic piece to force the windshield in its channel. End the installation at one of the upper corners.

**Note:** Two persons should be working on both faces of the windshield simultaneously.

11. Mask the outside of the windshield following the contour of the rubber extrusion.
12. Apply Sikaflex-255 FC adhesive generously between windshield and the rubber extrusion, while inserting the tip of the adhesive tube deep in the channel. Scrape off excess adhesive from windshield and clean with Klene-Sol or equivalent solvent.
13. Spray V-channel in the rubber extrusion with a liquid soap and water solution, and install filler strips in the rubber extrusion, cutting each end at a 45° angle.

**Note:** Filler strips retract with time. Install ends of filler strips as tight as possible in the V-channel.

14. Add Sikaflex-255 FC adhesive where the rubber extrusion meets the front structure fiber on the 2 sides not adjacent to the other windshield. Scrape off excess adhesive and clean with Klene-Sol or equivalent solvent.

15. Remove all masking tape and clean all areas properly. Reinstall windshield wiper and destination sign if applicable.
16. Let dry overnight or at least 8 hours before putting vehicle back into service.

## 13. ROOF ESCAPE HATCH

### 13.1 Maintenance

The vehicle can be equipped with one or two escape hatches. The escape hatch is designed to provide years of reliable service with a minimum of maintenance. All components are rust proof, and moving parts are Teflon coated to eliminate need for lubrication. Should water infiltrate the vehicle from the escape hatch, refer to the heading "Sealing" in this section for procedures on how to seal this area.

**Caution:** Use of lubricants, paints, or other coatings such as graffiti deterring sprays are not recommended.

Suggested maintenance includes periodic inspection of attaching fasteners for evidence of loosening due to tampering, and regular cleaning with mild soap and water.

Although there are other cleaning solutions available, some contain solvents and other chemicals that can attack the high strength materials used in the production of the escape hatch.

**Caution:** Ensure that cleaning solutions are compatible with the materials used on the escape hatch.

Graffiti removing cleaners often contain acetone, ether, lacquer thinner, or other solvents known to destroy the high strength properties of many plastics. Use of these cleaners must be avoided.

Graffiti-resisting coatings often leave a sticky residue that interferes with smooth up/down movement of the hatch mechanism. Some of these coatings also contain solvents that will reduce the strength of certain components.

**Caution:** Use of these coatings is at considerable risk and should be avoided.

### 13.2 Repair

All components used in the production of the escape hatch are available as service parts, except for one hinge that represents a possible hazard when improperly reattached to a hidden tapping plate that is often damaged whenever the hinge is damaged. The tapping plate is permanently laminated between the inner and outer cover assemblies, and it cannot be inspected or replaced. It is therefore necessary to replace the entire assembly following damage to the hinge. See figure 46.

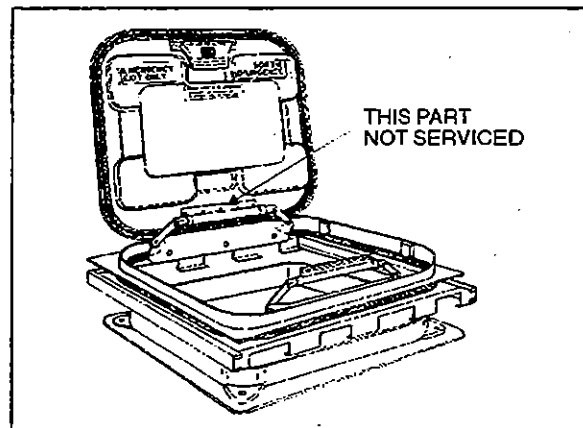

Figure 46

18104

**Caution:** Hinge assembly is critical and hinge should never be removed from cover assembly. Fasteners used in this assembly are special and have critical torque requirements and tamper-resistant heads to discourage tampering.

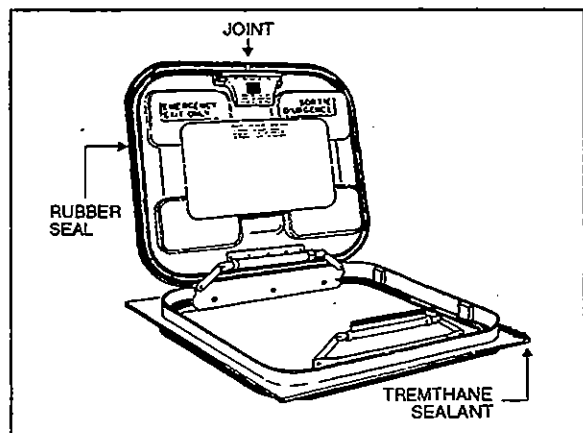

Figure 47

18105

### 13.3 Sealing

1. Open and tilt up the escape hatch cover.
2. Join the 2 ends of the rubber seal.

**Caution:** Seal joint should be toward rear of vehicle.

3. Apply rubber adhesive CA-40 (Prévost part no 68-1285) in the gap between the seal ends.
4. Apply Sikaflex 221 sealant (Prévost part no 68-0532) along the outline of the escape hatch on the roof of vehicle.

### 13.4 Removal and Installation

The frame of the escape hatch is riveted to the roof of the vehicle. The escape hatch panel assembly can be replaced as a unit and a new panel assembly installed in the existing frame. To remove the panel assembly, remove the 4 bolts fastening the 2 hinges to the escape hatch frame and retain the 4 flat washers. Reinstall the panel assembly by fastening the 2 hinges with the 4 bolts and flat washers removed earlier.

**Caution:** When installing, roof escape hatch's hinge must be toward the front of vehicle, to prevent the hatch from being ripped out if accidentally opened while vehicle is running.

## 14. PASSENGER SEATS

The H3-41 and H3-45 coaches can be equipped with any of 3 basic seat models and installed in a variety of seating arrangements:

1. The "Tourismo 2" seat is the base model and is available in heights of 40" (102 cm) and 42" (107 cm). Seating arrangement includes 2 card tables which can be folded and removed, and pivoting seats ahead of each card table. Each pair of seats is built on a welded steel frame fastened to the side wall and on a track-mounted pedestal. Standard seating capacity is 48 in H3-41 and 56 in H3-45.
2. The "Silhouette" seat is an optional model with each pair also built on a welded steel frame and mounted the same way as the "Tourismo 2" seat. Standard seating arrangement with the "Silhouette" seat includes 2 card tables and 2

pivoting seats. Seating capacity is the same as with the "Tourismo 2" seat.

3. The "VIP" seat model is an optional seat. "V.I.P." seats are mounted on one row of paired seats built on a common frame on one side of the vehicle, and a row of single seats on the other side of the vehicle with an off-centre aisle. Each "V.I.P." seat has its own set of armrests.

Each seat has a removable bottom cushion with snapped-on upholstery for cleaning or replacement. The "Tourismo 2" and "Silhouette" seats have 3 armrests. The aisle armrest is spring loaded to return to its down position when released. The center armrest can be folded up and down manually, while the window armrest is fixed.

### 14.1 Rotating Seats

1. Remove 1 wing nut holding each seat bottom cushion from under the seat frame.
2. Lift front part of cushions and remove cushions.
3. Remove 4 wing screws fastening seat assembly to seat frame.
4. Pull seat toward aisle and rotate.
5. Align mounting holes and reinstall 4 wing screws.
6. Reinstall seat bottom cushions with wing nuts.

### 14.2 Removing Fixed Seats

**Note:** Seats on one row are not interchangeable with seats of the other row.

To remove fixed seats, proceed as follows:

1. Remove 1 elastic stop nut holding each seat bottom cushion from under the front part of the seat frame.
2. Lift front part of cushions and remove cushions.
3. Remove 4 finishing screws holding plastic cover between side wall and seat frame.
4. Remove 2 cap screws, nuts, and washers holding seat frame to side wall and retain the 2 holding brackets. See figure 48.

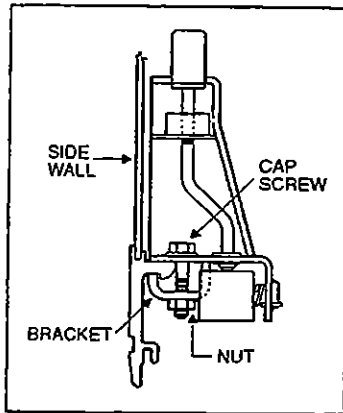

Figure 48

18106

- Remove 2 nuts and washers holding seat frame to pedestal rods. See figure 49.

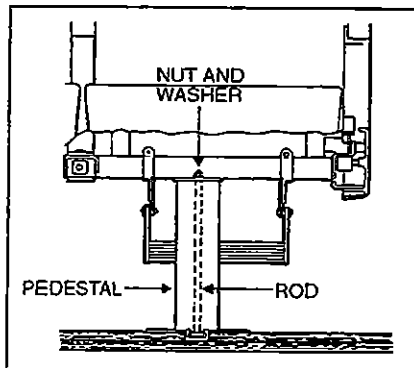

Figure 49

18107

**Note:** Bottom end of rod is coated with Loctite and threaded in a steel block which slides in the floor track. Removal of rod is possible if loosened from block. Otherwise, slide rod and block assembly to the front end of track after removing all other interfering seats.

- Remove seat assembly.
- Reverse the above procedure to install seat assembly.

**Note:** On newer vehicles, the rod consists of a carriage bolt inserted in a square plate sliding in the floor track. Removal is possible only by the front end of track.

## 15. UPHOLSTERY MAINTENANCE

### 15.1 Routine Cleaning

Coach seats are lightweight, with foam-padded backs and cushions. For both appearance and wearability, best results are obtained if upholstery is cleaned at regular intervals before dirt, dust and grit have been ground into the fabric. Seat fabric is made of 50% wool, 33% cotton, 9% nylon, and 8% acrylic.

All that is required to remove the dirt is a gentle beating with the hand or the back of a brush. This will bring the dirt to the surface where it is easily removed with a vacuum or brush in the direction of the pile which can easily be recognized by running a hand lightly over the pile. If the fabric become excessively dirty, particles of grit will cause gradual wear, reducing the life span of the fabric.

### 15.2 Dry Cleaning

If covers are to be removed for cleaning, dry cleaning is recommended since washing might cause some shrinkage, preventing the covers from being reapplied to the seats without damage. Other than spot cleaning the covers while they are in place, dry cleaning is not recommended, since the resulting fumes could be hazardous in the confines of the coach and the solvent could be detrimental to the foam padding of the seats.

### 15.3 Cleaning With Covers in Place

The most effective and economical method to clean the fabric seat covers is by washing with either an approved foam upholstery cleaner or with a mild household detergent.

- Thoroughly vacuum the upholstery. Remove any spots or stains before the seats are washed to avoid a cleaning ring.
- Dilute household detergent or liquid foam cleaner according to directions on the con-

## Section 18: BODY

tainer. Pour a small quantity into a flat pan and work into a thick foam with a sponge or brush.

3. Apply only the foam to the fabric with a sponge or brush. Clean a small area of the fabric at a time with the foam. **DO NOT SOAK.** Rub vigorously.
4. Sponge the suds from the fabric with a clean sponge or cloth moistened with water. Rinse the sponge or cloth often and change the water when it becomes dirty.
5. Allow the upholstery to dry completely before the coach goes back into service. To speed up drying, excess moisture can be blown off the fabric with compressed air.

**Note:** Oil in the air line will soil the fabric. Blow the line clear and test air discharge against a plain white piece of paper. It is also effective to press the edge of a flat hardwood stick down on the cushion and slowly draw it across the fabric.

Even very soiled areas can be returned to their original appearance by a thorough cleaning, but a regular schedule of cleaning that keeps the upholstery reasonably clean at all times will add months to the service life of coach upholstery.

## 16. VEHICLE JACKING POINTS

The vehicle can be jacked by applying pressure under body jacking points or front and drive axle jacking points. When it is necessary to raise the vehicle, care should be taken to ensure that pressure is applied only at the points indicated in figure 50, 51 and 52. Equipment for lifting the front of the vehicle must have a combined lifting capacity of 13,000 lbs (5 900 kg). Equipment for lifting the rear of the vehicle must have a combined lifting capacity of 25,000 lbs (11 400 kg).

**Warning:** Extra lift capacity may be required if luggage or any other type of load (e.g. conversion equipment) are onboard the vehicle.

### 16.1 Body Jacking Points

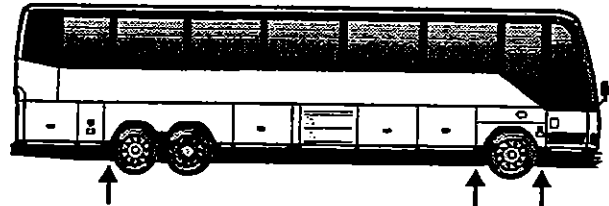

Figure 50

18083

**Warning:** The suspension of the vehicle must be in the normal ride position before jacking. The "Level Low" system on a motorcoach must be in the "DRIVE" position prior to turning the ignition key "OFF".

### 16.2 Axle Jacking Points

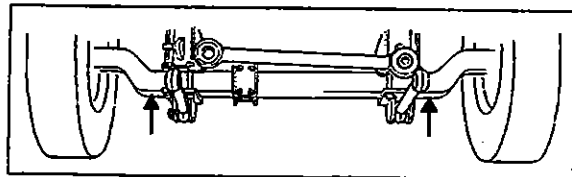

Figure 50: Front Axle

18084

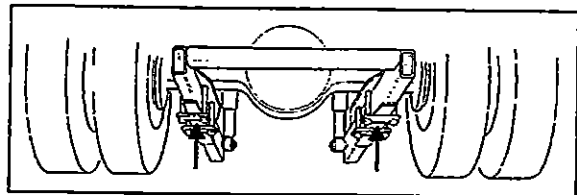

Figure 51: Drive Axle

18085

**Warning:** Always unload or retract the tag axle before jacking the vehicle from the front and drive axle jacking points to prevent damage to suspension components.

### 16.3 Jacking the Tag Axle

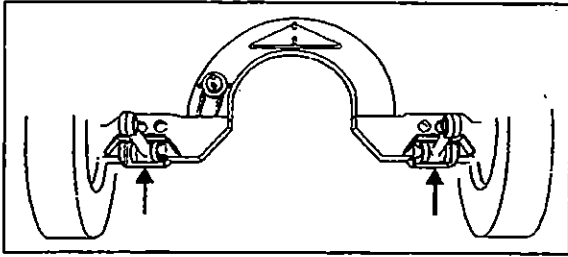

Figure 53: Tag Axle

18086

**Warning:** The jacking points on the tag axle must be used for raising the tag axle only.

## 17. TOWING THE VEHICLE

The vehicle can be transported on a low bed semi-trailer of adequate gross axle weight capacity. When transporting a vehicle, apply parking brake and shut down the engine. Block all wheels and secure vehicle with tie-downs. Check that overall height will clear obstacles on the route to follow, and obtain required permits as required.

The vehicle can also be towed by lifting under the front axle or by towing from the front with all wheels on the ground. These 2 methods are described below under their respective headings. Whatever the method used, the vehicle should be towed by truck operators authorized and experienced in towing intercity coaches.

Observe normal precautions including, but not limited to, the ones listed below when towing the vehicle:

1. Make sure the parking brake is released before towing.
2. Do not allow passengers to ride inside the towed vehicle.
3. Tow the vehicle at a safe speed as dictated by road and weather conditions.
4. Accelerate and decelerate slowly with caution.

### 17.1 Lifting and Towing

The towed vehicle must be lifted from under the front axle only. The tow truck must be equipped with the proper lifting equipment to reach under

the front axle since no other lifting points are recommended. Lifting and towing from any other point are unauthorized as it may cause serious damage to the structure. **Do not unload or raise the tag axle when lifting and towing to prevent overloading the drive axle.**

1. Remove both drive axle shafts to prevent damage to the transmission. Plug axle tube to prevent oil loss. Refer to Rockwell's "Maintenance manual no.5" in Section 11 "Rear Axle" in this manual for correct procedure.

**Caution:** Transmission lubrication is inadequate when towing. With either automatic or manual transmission, the drive axle shafts must be removed to avoid serious damage to the transmission.

2. Operate the engine of the vehicle when towing to maintain brake system air pressure. If the engine cannot be operated, connect an external air pressure line from the tow truck to the emergency fill valve in the engine compartment. The emergency fill valve in the front service compartment does not supply air pressure to the brake system. The air pressure must be a minimum of 75 psi (520 kPa), and the line should be attached to the air line with a clip-on chuck.

**Caution:** Do not tow the vehicle without external air pressure applied to the emergency fill valve if the engine does not operate. Without brake system air pressure, the brakes may apply automatically if system air drops below 40 psi (275 kPa). If failure prevents releasing the parking brakes with air pressure, disengage the parking brakes mechanically.

3. Lift the vehicle from under the front axle, and adequately secure the underside to the tow vehicle lifting attachment with chains.
4. Observe safety precautions when towing.

### 17.2 Towing Without Lifting

**Caution:** When towing without lifting vehicle, use only a tow truck with a solid link tow bar and related equipment. All other means of towing are unauthorized. Tow only from the front of the vehicle.

1. Remove both drive axle shafts to prevent damage to the transmission. Plug axle tube to

## Section 18: BODY

---

prevent oil loss. Refer to Section 11, "Rear Axle" in this manual for correct procedure.

**Caution:** *Transmission lubrication is inadequate when towing. With either automatic or manual transmission, the drive axle shafts must be removed to avoid serious damage to the transmission.*

2. Operate the engine of the vehicle when towing to maintain brake system air pressure. If the engine cannot be operated, connect an external air pressure line from the tow truck to the emergency fill valve in the engine compartment. The emergency fill valve in the front service compartment does not supply air pressure to the brake system. The air pressure must be a minimum of 75 psi (520 kPa), and the line should be attached to the air line with a clip-on chuck.

**Caution:** *Do not tow the vehicle without external air pressure applied to the emergency fill valve if the engine does not operate. Without brake system air pressure, the brakes may apply automatically if system air drops below 40 psi (275 kPa). If failure prevents releasing the parking brakes with air pressure, disengage the parking brakes mechanically.*

3. Position the tow truck so that the tow bar contacts the front bumper of the vehicle.
4. Attach the tow truck chains in the tow eyes of the vehicle under the bumper and take up all the slack.
5. Attach safety chains as applicable.
6. Observe safety precautions when towing.





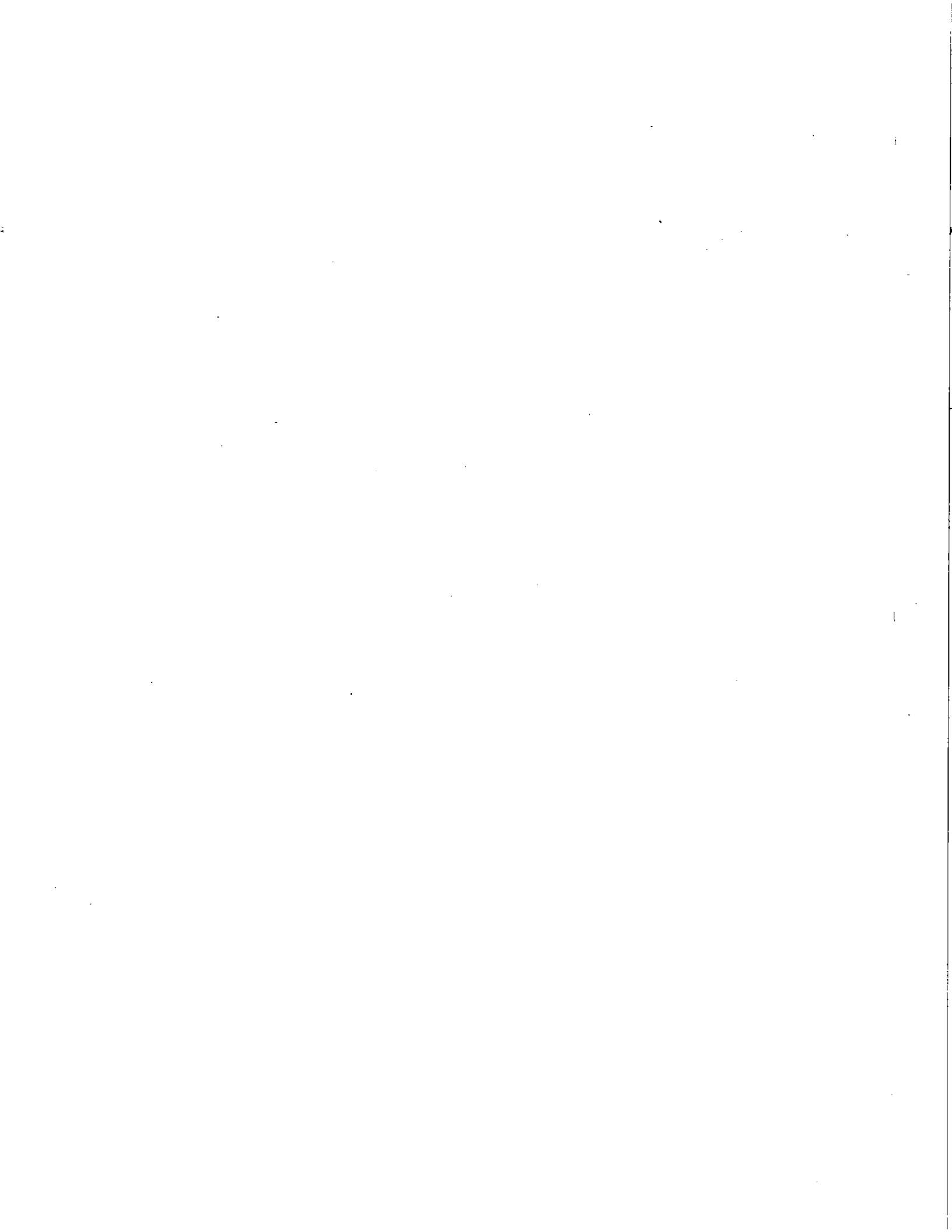

# SECTION 22: HEATING AND AIR CONDITIONING

---

## CONTENTS

1. HEATING AND AIR CONDITIONING .....	4
1.1 Description .....	4
2. AIR CIRCULATION .....	4
2.1 Driver's Area .....	4
2.2 Central Section (Passengers) .....	4
3. DRIVER'S HVAC SYSTEM OPERATION .....	5
4. MAIN HVAC SYSTEM OPERATION .....	5
5. DIAGNOSIS OF MAIN HVAC UNIT PROBLEMS .....	9
5.1 High Pressure Orange LED .....	10
5.2 Low Pressure Orange LED .....	10
5.3 Driver's Red LED .....	10
5.4 Humidistat Yellow LED .....	11
6. MAIN HVAC UNIT TROUBLESHOOTING GUIDE .....	12
6.1 Control Temperature Chart .....	13
6.2 Checking Potentiometer Resistance Values .....	15
6.3 Checking the Sensor Resistance Values .....	15
6.4 Testing Each Sensor .....	15
6.5 Fresh Air Inlet Sensor .....	18
6.5.1 Description .....	18
6.5.2 Checkout .....	18
7. HVAC UNIT MAINTENANCE .....	18
7.1 Coil Cleaning .....	18
7.2 Driver's HVAC Unit Air Filter .....	19
7.3 Main HVAC Unit Air Filter .....	19
8. EVAPORATOR MOTOR .....	20
8.1 Removal .....	20
8.2 Installation .....	20
8.3 Maintenance .....	20
8.3.1 Checking Operation of Brush in Holder .....	20
8.3.2 Brush Wear Inspection and Replacement .....	21
8.3.3 Checking Commutator .....	21
8.4 Speed Controller Module .....	21
8.4.1 Troubleshooting .....	21
9. AIR CONDITIONING SYSTEM .....	22
9.1 Description .....	22
9.2 A/C Cycle .....	24
9.3 Refrigerant .....	24
9.3.1 Procurement .....	24
9.3.2 Precautions in Handling Refrigerant .....	24
9.3.3 Treatment in Case of Injury .....	25
9.3.4 Precautions in Handling Refrigerant Lines .....	25
9.4 Pumping Down .....	26
9.5 Adding Refrigerant (Vapor State) .....	27
9.6 Evacuating System .....	27

**Section 22: HEATING AND AIR CONDITIONING**

---

9.7 Charging System .....	28
9.8 Refrigerant System Cleanout After Compressor Failure .....	28
9.8.1 Determining Severity of Failure .....	29
9.8.2 Cleanout after Minor Compressor Failure .....	29
9.8.3 Cleanout After Major Compressor Failure .....	29
10. A/C SYSTEM COMPONENTS .....	30
10.1 Compressor (Central System).....	30
10.1.1 Belt Replacement.....	30
10.1.2 Pulley Alignment .....	30
10.1.3 Longitudinal Compressor Alignment.....	30
10.1.4 Horizontal Compressor Alignment.....	30
10.1.5 Vertical Compressor Alignment.....	31
10.1.6 Compressor Maintenance .....	31
10.1.7 Troubleshooting Guide .....	31
10.2 Magnetic Clutch .....	32
10.2.1 Time Delay Module .....	32
10.3 Condenser .....	33
10.3.1 Condenser Fan Motors .....	33
10.3.2 Condenser Fan Motor Removal .....	33
10.3.3 Preliminary Disassembly .....	33
10.3.4 Disassembly.....	33
10.4 Receiver Tank.....	34
10.5 Filter Dryer .....	34
10.5.1 Description .....	34
10.5.2 Replacement.....	34
10.5.3 Moisture Indicator .....	35
10.6 Liquid Refrigerant Solenoid Valve .....	35
10.6.1 Description .....	35
10.6.2 Manual Bypass .....	35
10.6.3 Coil Replacement.....	35
10.6.4 Valve Disassembly.....	36
10.6.5 Valve Reassembly .....	36
10.7 Humidistat .....	36
10.7.1 Description .....	36
10.7.2 Setting .....	37
10.7.3 Checkout .....	37
10.7.4 Maintenance.....	37
10.8 Expansion Valve .....	38
10.8.1 Main System.....	38
10.8.2 Driver's System .....	40
10.9 Torch Brazing .....	40
10.10 Troubleshooting .....	41
10.10.1 Expansion Valve .....	41
10.10.2 A/C .....	42
10.11 Temperatures and Pressures.....	43
10.12 Leak Testing .....	45

11. HEATING SYSTEM .....	45
11.1 Description.....	45
11.2 Draining Heating System.....	47
11.2.1 Driver's Heater Core .....	47
11.2.2 Main Heater Core.....	47
11.3 Filling Heating System.....	48
11.4 Bleeding Heating System .....	48
11.5 Soldering.....	48
12. HEATING SYSTEM COMPONENTS.....	48
12.1 Driver's Water Solenoid Valve.....	48
12.1.1 Description .....	48
12.1.2 Improper Operation.....	49
12.1.3 Coil Replacement.....	49
12.1.4 Valve Disassembly.....	49
12.1.5 Valve Reassembly .....	51
12.2 Main Hot Water Solenoid Valve Actuator.....	51
12.2.1 Description.....	51
12.2.2 Valve Actuator Removal (Figure 35).....	52
12.2.3 Valve Repacking.....	52
12.2.4 Valve Rebuilding.....	52
12.2.5 Disassembly Procedures .....	52
12.2.6 Maintenance .....	53
12.3 Water Recirculating Pump.....	53
12.3.1 Description .....	53
12.3.2 Removal.....	53
12.3.3 Disassembly (Refer to Figure 37-Water Recirculating Pump and Motor) .....	53
12.3.4 Brushes .....	55
12.3.5 Bearings (Figure 37) .....	55
12.3.6 Commutator .....	55
12.3.7 Miscellaneous (Figure 37) .....	56
12.3.8 Assembly (Figure 37).....	56
12.3.9 Installation .....	56
12.4 Water Filter .....	57
12.4.1 Description .....	57
12.4.2 Maintenance.....	57
12.4.3 Filter Servicing (Figure 38) .....	58
12.5 Bypass Solenoid Water Valve (optional).....	58
12.5.1 To Remove or Change the Coil.....	58
12.5.2 To Take The Valve Apart .....	58
12.6 Preheating System (Optional) .....	59
12.6.1 Espar.....	59
12.6.2 Webasto.....	60
12.6.3 Preheating System Timers (Auxiliary) (Optional) .....	60
12.6.4 Troubleshooting and Maintenance .....	60
13. SPECIFICATIONS .....	61

## 1. HEATING AND AIR CONDITIONING

### 1.1 Description

The coach's interior is pressurized by its Heating, Ventilation, Air Conditioning (HVAC) units. Air flow and controls divide the vehicle in two sections: driver's and Central (passengers) sections.

The interior of vehicle should always be slightly pressurized to prevent dust and moisture from entering vehicle. Each section has its own fresh air, returning air and discharge air ducting. The exhaust is mainly done through the lavatory ventilator and through normal air-tightness losses.

## 2. AIR CIRCULATION

### 2.1 Driver's Area

Fresh air is taken from a plenum behind the front bumper and enters the mixing box through an adjustable damper. Returning air is taken through a front dash panel into the mixing box. The "Driver A/C-Heating Recirc.-Fresh Air" control is located on the R.H. dashboard control panel. Mixed air goes through cooling and heating coils, fans and discharge ducts.

Both right and left discharge ducts defrost one half of the windshield. The driver can also, with the "Main Windshield Defroster" control divert his air flow to the console, from which he can direct vent to his knees and/or upper body with adjustable HVAC register and to his feet with the lever (Fig. 1).

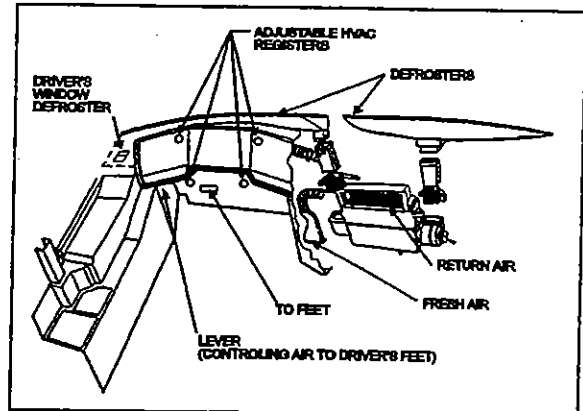

Figure 1: Driver's Air Circulation

22020

### 2.2 Central Section (Passengers)

Fresh air is taken from the left side of vehicle through a two-position damper located at the left of the HVAC compartment. The pneumatic control damper can be fully opened for normal operation or partially closed for extreme weather or highly polluted areas. The "Fresh Air Damper" switch is located on the R.H. side lower control panel. Push down the rocker switch to partially close the fresh air damper. Refer to the H3 Operator's Manual for details.

Return air is drawn through the last entrance step riser and from the lower section of the floor ducts in two locations: one in the rear section of vehicle and the other in the front section of vehicle on the L.H. side (Fig. 2).

A double blower fan unit, which is activated by the evaporator motor, draws mixed air through an air filter, cooling and heating coils, then forces this air in the ventilation ducts (upper section) along the walls, and finally exhausts it at the bottom of the windows.

The lavatory ventilator acts as the main exhaust for the whole vehicle, eliminates odors, and finally heats or cools the lavatory with the vehicle's ambient air.

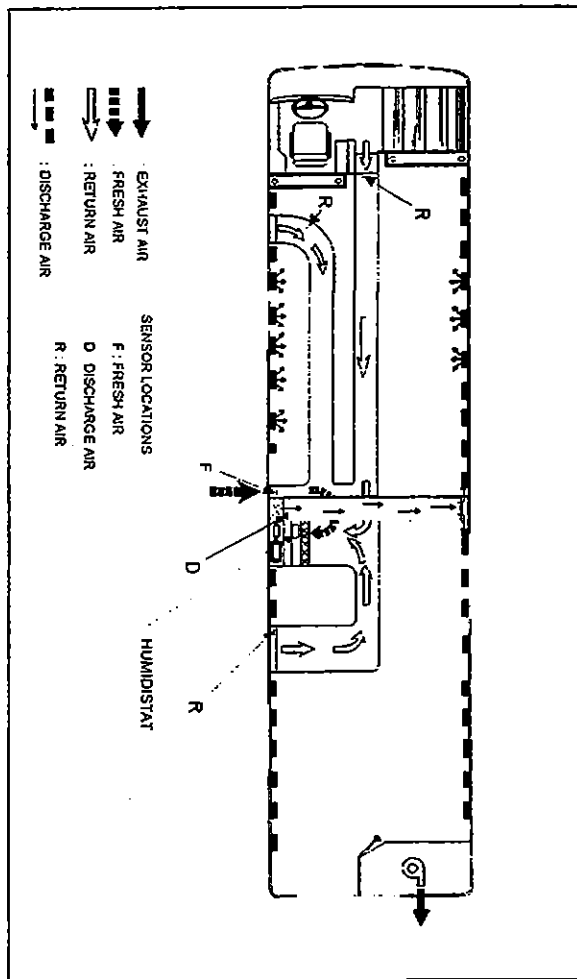

Figure 2: Main HVAC System Air Circulation

### 3. DRIVER'S HVAC SYSTEM OPERATION

The temperature control in the driver's area is provided by the "Driver's A/C - Heating Temperature" control mounted on the R.H. dashboard control panel, which is in fact a potentiometer, and by a thermistor sensor located under the dashboard close to the accelerator pedal. At extreme clockwise position, the temperature control will deliver full heat without any control.

The fan speed will be set by the position of the "Driver's A/C - Heating Ventilation Speed" control, also mounted on the R.H. dashboard control

panel which has two functions. The clicking noise produced while turning the control activates the heating or A/C system according to the "Driver's A/C - Heating Temperature" control position. This control also acts as a potentiometer. Consequently, it is possible to gradually increase speed of fan motor from 25% to maximum speed. An electronic module, mounted on the driver's HVAC unit, analyzes the value sent to the potentiometer, and thus sets the motor speed. This installation ensures economical operation, and a wide range of speeds.

The driver's HVAC unit piping is paralleled with the main HVAC unit piping. Both units use the same refrigerant and coolant, and are linked to the same condenser and compressor, even if they are individually controlled. It requires the main HVAC unit to engage the A/C compressor magnetic clutch. Consequently, the driver's unit cannot be operated in the A/C mode alone.

### 4. MAIN HVAC SYSTEM OPERATION

The "Main A/C - Heating" switch, located on the R.H. side lower control panel, operates the A/C-heating and ventilation system (HVAC) in the Main section. The "Main A/C - Heating Temperature" control, located on the R.H. side dashboard control panel, enables the selection of the temperature in the main section (refer to the H3 Operator's Manual for details). The evaporator motor installed in HVAC compartment on the L.H. side of vehicle is protected by a 150 amp, manually-resettable (CB8) circuit breaker mounted in the main power compartment (refer to Section 06, "Electrical System" in this manual for details).

The condenser mounted on the opposite side of the evaporator is ventilated by two axial fans. Each axial fan motor is protected by a manually-resettable 40 amp circuit breaker mounted on the L.H. side wall of the A/C and heating junction box (Fig. 3). Furthermore, the feeding circuit of these two breakers is protected by a 150 amp manually resettable (CB9) circuit breaker mounted in main power compartment (Fig. 4).

## Section 22: HEATING AND AIR CONDITIONING

To operate air conditioning system when coach is stationary, engine should run at fast idle. During operation of air conditioning system, windows should be kept closed and door not left open longer than necessary. In order to prevent battery discharge, A/C-heating system will not operate if vehicle charging system is not working properly.

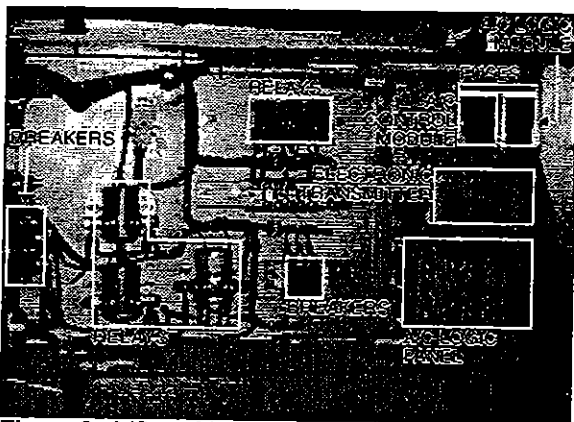

Figure 3: A/C and Heating Junction Box 06061

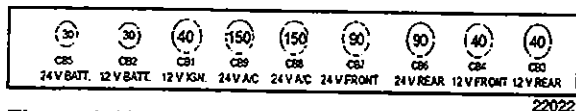

Figure 4: View from the Main Power Compartment

The heating and cooling components (water recirculating pump, main hot water valve actuator, A/C compressor clutch and unloaders, etc) are connected to the HVAC logic panel mounted on the A/C and heating junction box sliding drawer (Fig. 5).

Air temperature is picked up by three identical sensors, each one located in one of the three returning air ducts, and by another sensor located in the discharging air duct (Fig. 2). As shown in Figure 6, the sensors are series parallel connected. The electronic transmitter (see Fig. 5 and 6) detects the sensor signal and then compares it with the driver's setpoint ("Main A/C - Heating Temperature" control, which is mounted in R.H. dashboard control panel).

This will result in a voltage range (Fig. 7) for the HVAC logic panel. At this point, a fresh air sensor located in the fresh air damper on L.H. side of vehicle, can modify this range to anticipate any major change in the outside temperature. Afterwards, the HVAC logic panel will select the appropriate heat or cooling contact and staging according to the actual conditions. On the HVAC logic panel, there are three heat and three cooling contacts (see fig. 6).

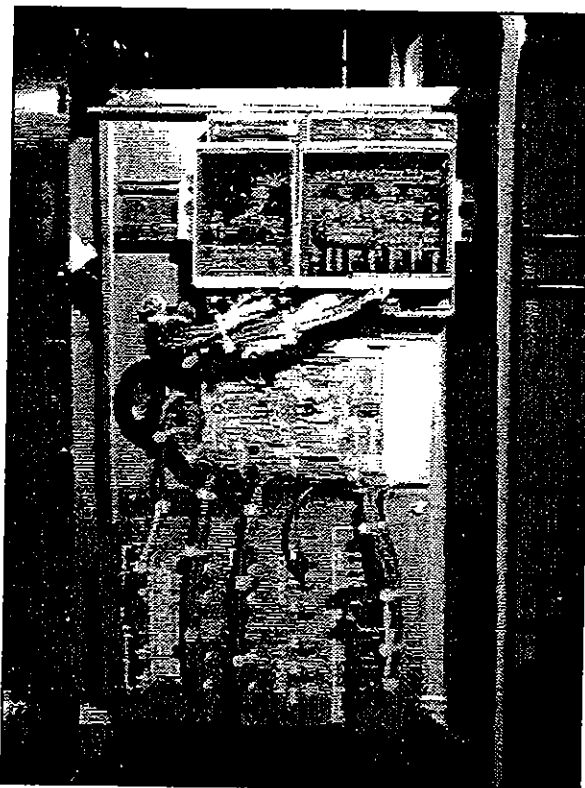

Figure 5: A/C Heating Junction Box Sliding Drawer 06062

### In the Heat Mode

Heat in the system varies with the restricted opening of the linear main hot water valve actuator, the bypass solenoid valve and the action of the water recirculating pump.

When the preheater is switched on, the bypass solenoid water valve opens, except if **heat contact 3** is on. At this time the main hot water valve actuator should be fully open. The main hot water valve actuator is controlled by the heat voltage ramp (Fig. 7). The **heat contact** starts the water recirculating pump. **Heat contact 1** is for diagnosis (see next paragraph) and **heat contact 2** controls nothing.



**In the Cooling Mode**

Contact will vary with the number of active cylinders in the compressor by means of electric unloaders. Staging will be defined as follows:

**No cooling contact:** Compressor clutch is disengaged.

**Cooling contact 1:** Compressor clutch is engaged and 2 compressor active cylinders.

**Cooling contact 2:** Compressor clutch is engaged and 4 compressor active cylinders.

**Cooling contact 3:** Compressor clutch is engaged and 6 compressor active cylinders.

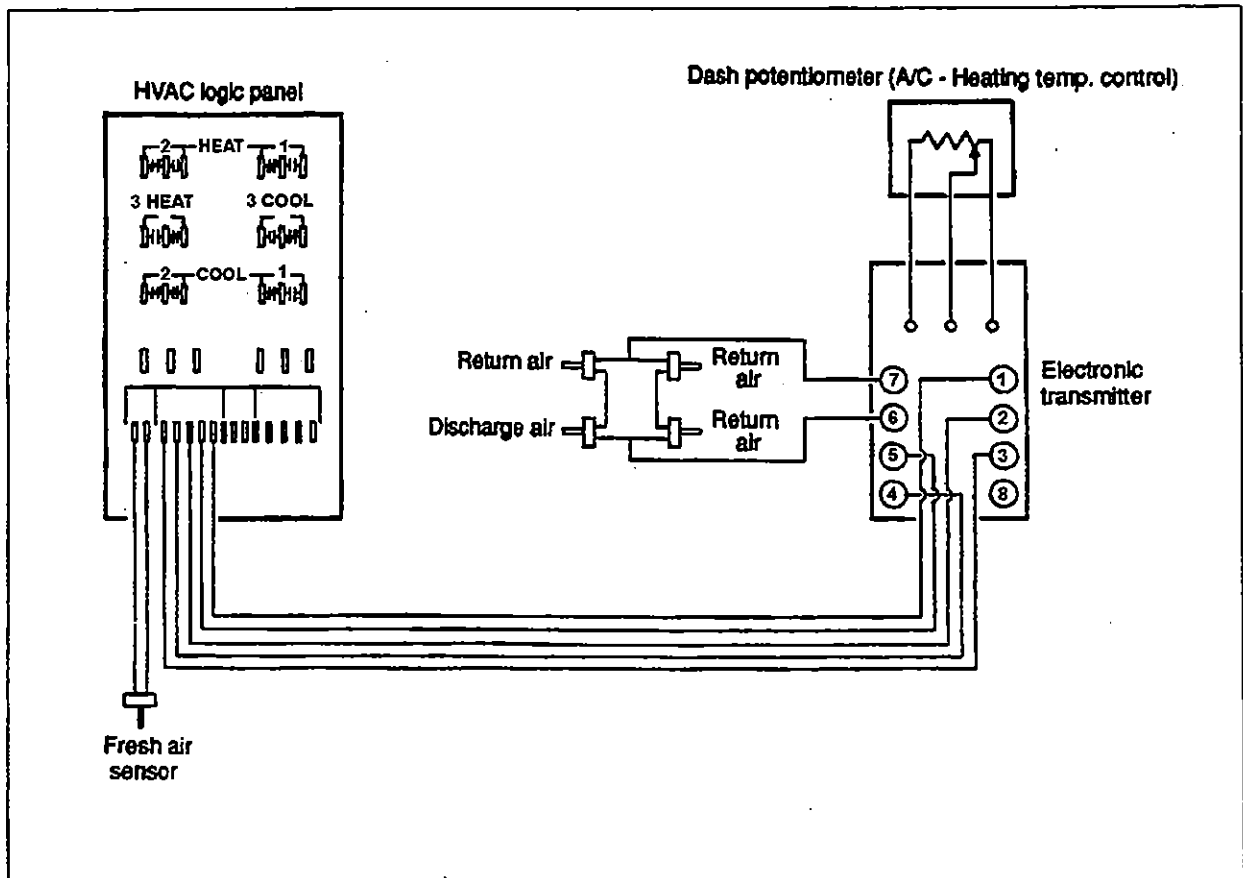

Figure 6

22023

Section 22: HEATING AND AIR CONDITIONING

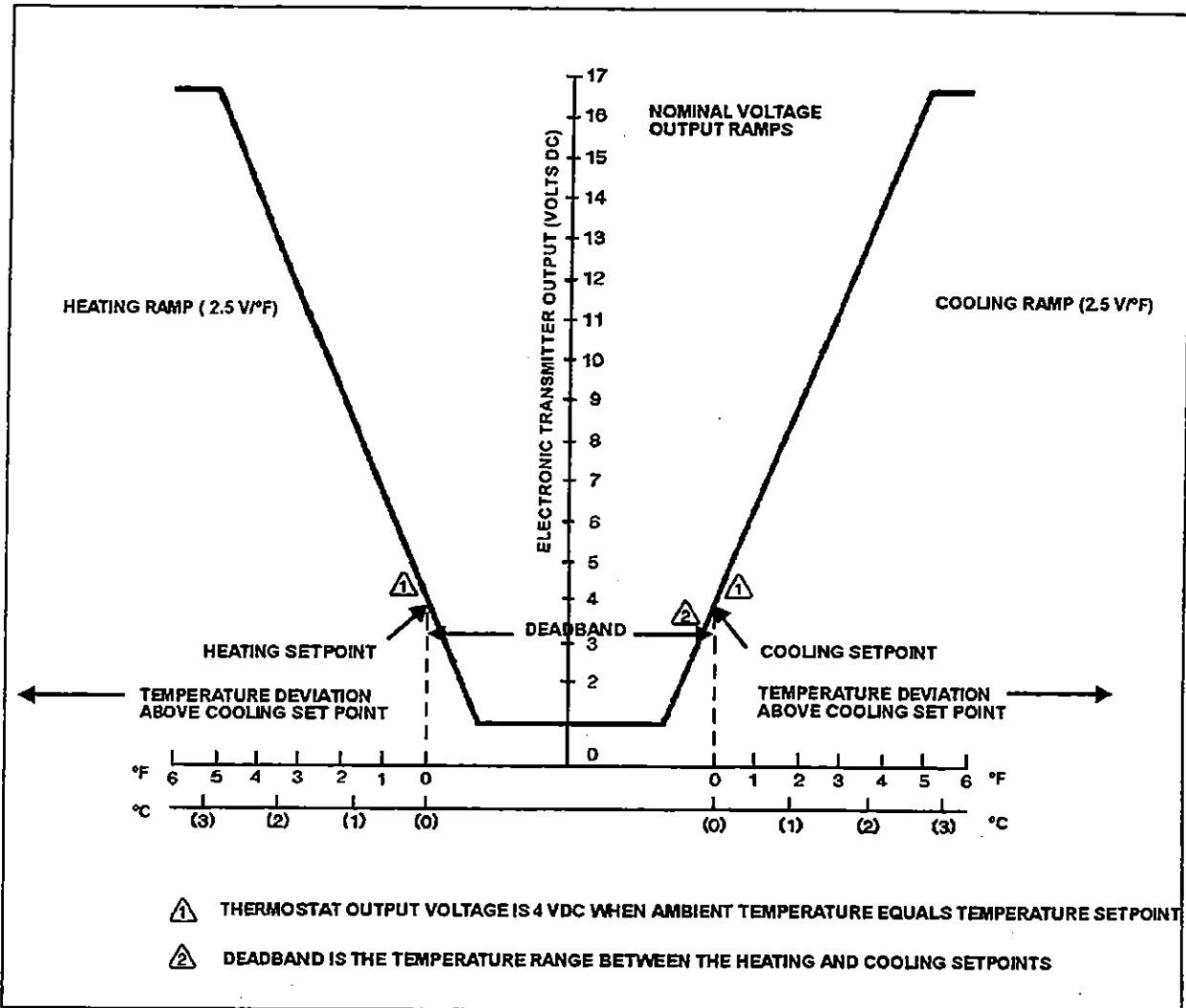

Figure 7: Electronic Transmitter Output Voltage Ramps

22024

## 5. DIAGNOSIS OF MAIN HVAC UNIT PROBLEMS

Troubleshooting the HVAC system is made easier with the LEDs (light-emitting diodes) integrated in the system, and acting as indicator lights.

The main HVAC unit is equipped with three LEDs to indicate the heating mode and are located as follows:

One red LED is located on the **electronic transmitter** and identified "Heat" (Fig. 8). The electronic transmitter picks up the sensor signal and compares it with the setpoint established by the driver ("Main A/C - Heating Temperature" control). After analysis, a voltage signal, of which value is proportional to the analysis result (sensor vs driver's setpoint), is transmitted to the HVAC logic panel. The red LED on the electronic transmitter will be illuminated according to the voltage value, i.e. red LED may not be illuminated at first, and then will gradually reach its maximum brightness or vice versa.

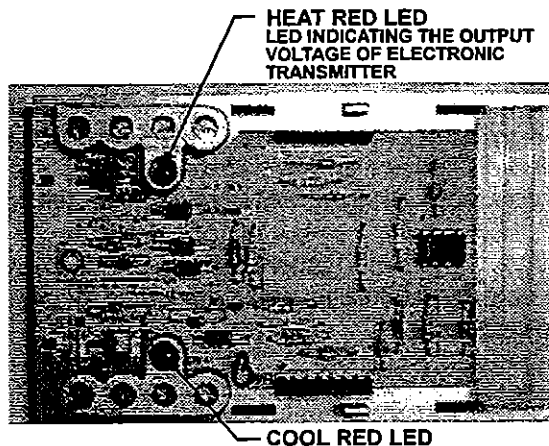

Figure 8: Electronic Transmitter 22025

Two other red LEDs connected in parallel are located as follows:

One red LED is located in **driver's compartment**, on the lower console under the inside thermometer, while the other red LED is located

on the HVAC logic module, which is mounted right over the electronic transmitter (Fig. 9). The two red LEDs operate simultaneously; unlike the LED mounted on the electronic transmitter, they may be illuminated or not ("ON" or "OFF"). Their function is to indicate the output of the HVAC logic panel.

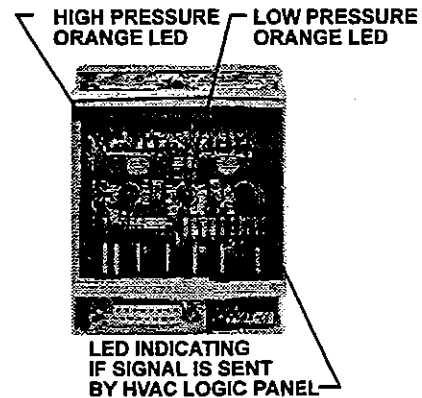

Figure 9: HVAC Logic Module 22026

The HVAC logic panel reads the voltage from the electronic transmitter. As soon as the voltage reaches 4.6 volts, the HVAC logic panel opens the normally-closed **heat contact 1**.

At this stage, the two red LEDs will illuminate to indicate that the HVAC logic panel has sent a signal to activate the heating system. If the other stages are activated, the two LEDs will remain illuminated.

The red LED on the lower console advises the driver that the heating system is operating. The red LED mounted on the HVAC logic module enables the technician to quickly diagnose the problem.

As for the A/C mode, it is almost the same installation, except that the red LED on the electronic transmitter is identified "Cool". Its operation is, however, identical.

The significant difference lies in the fact that the two other LEDs connected in parallel are green. One green LED is located in the driver's compartment on the lower console under the inside

## Section 22: HEATING AND AIR CONDITIONING

---

thermometer, while the other one is located on the HVAC control module. These two LEDs indicate the operation of the A/C system.

When the humidistat requests the operation of the A/C system to dry ambient air inside the vehicle, the two green LEDs will illuminate to indicate the operation of this system. However, the "Cool" red LED on the electronic transmitter will not illuminate, because the humidistat control bypasses the electronic transmitter. Therefore it is normal for the driver who requests heat by means of the "Main A/C - Heating Temperature" control, that the red and green LEDs be illuminated simultaneously. This corresponds to the operation of the heating system to heat the vehicle, and to the operation of the A/C system to dry air (dehumidification).

**Note:** *The dehumidifying function will operate only when the humidistat requests dehumidification AND the ambient temperature inside vehicle is less than 4°F (2°C) from the selected temperature with "Main A/C - Temperature" control.*

In addition to the two LEDs on the electronic transmitter and to the four other ones used to indicate the output of HVAC logic panel, four other LEDs described hereafter have been added on the HVAC control module and HVAC logic module to help the technician to quickly diagnose the problem.

### 5.1 High Pressure Orange LED

This LED mounted on the HVAC logic module (Fig. 9), is designed to light up when the pressure inside the A/C system (high pressure side) is too high. If this occurs, perform the following checks:

1. Too high air inlet temperature to the condenser;
2. Dirty condenser;
3. Faulty condenser fans; or
4. Refrigerant overcharge.

**Note:** *Another indicator light, "High A/C Pressure Indicator", mounted in the dashboard will also illuminate in order to inform the driver of this abnormal situation.*

**Note:** *If the A/C pressure is too high, the compressor clutch is disengaged, but the fan remains active.*

### 5.2 Low Pressure Orange Led

This LED, also mounted on the HVAC logic module (Fig. 9), is designed to light up when the pressure inside the A/C system (low pressure side) is too low. If this occurs, perform the following checks:

1. Too low air inlet temperature to condenser and/or evaporator;
2. Dirty evaporator air filter;
3. Dirty evaporator;
4. Low refrigerant charge; or
5. Expansion valve freeze up.

**Note:** *Another indicator light "Low Conditioning A/C Pressure Indicator", mounted in the dashboard will also illuminate in order to inform the driver of this abnormal situation.*

**Note:** *If the A/C pressure is too low, the compressor clutch is disengaged and the fan is deactivated.*

### 5.3 Driver's Red LED

This LED, mounted on the HVAC control module (Fig. 10), will turn on to indicate the energization of the driver's liquid refrigerant solenoid valve, each time there is a cooling request by the "Main A/C - Heating Temperature" control and the driver's system fan is on.

**Note:** Cooling mode in driver's compartment will remain inoperative as long as central A/C system has not been turned on. Furthermore, central A/C system must be in cooling mode and not in dehumidifying mode, to allow cooling of the driver's compartment as driver's evaporator unit never operates in the dehumidifying mode.

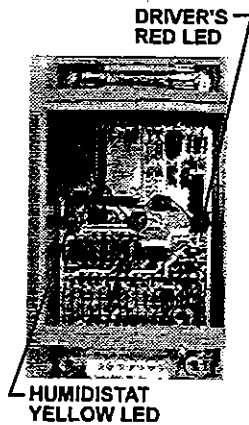

Figure 10: HVAC Control Module

22027

## 5.4 Humidistat Yellow LED

This LED, mounted on the HVAC control module (Fig. 10), will be turned on (full intensity) during a dehumidifying request. It can also be half illuminated during a heat request.

**Note:** Even if the dehumidifying function is requested, the cooling contact 1 on the HVAC logic panel will not turn on as long as the ambient temperature inside the vehicle will be over than 4 °F (2 °C) from the selected temperature with "Main A/C - Temperature" control.

## 6. MAIN HVAC UNIT TROUBLESHOOTING GUIDE

System does not operate with the "Passenger A/C-Heating" switch in the "ON" position

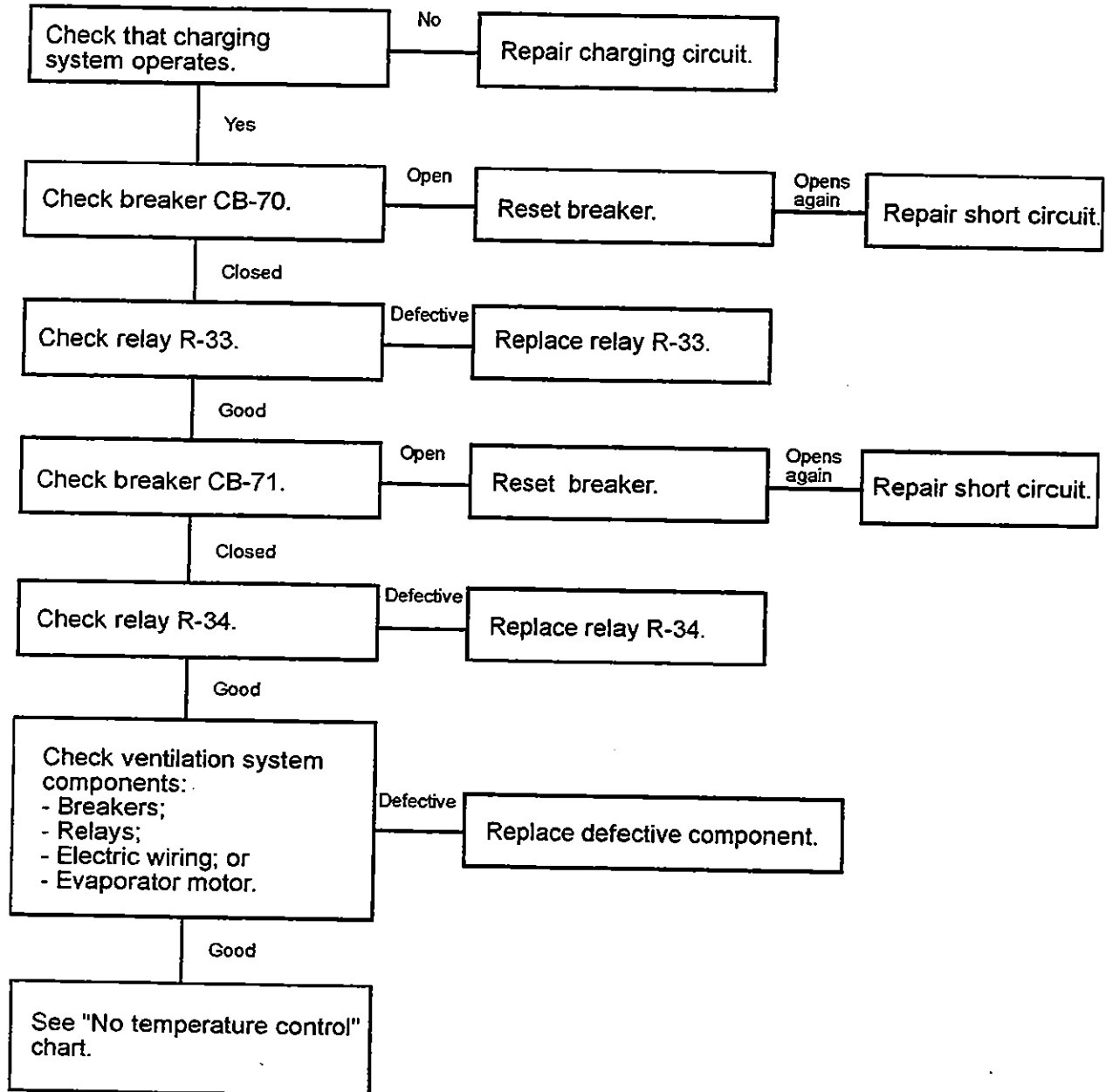

Diagram 1: Troubleshooting Chart - Main HVAC Unit

## 6.1 CONTROL TEMPERATURE CHART

Ventilation operates, but there is "no temperature control".

Turn "Passenger A/C-Heating Temperature" control to extreme clockwise or counterclockwise position (cold or warm).

Set humidistat (located in HVAC compartment over evaporator motor) to its maximum position to inhibit operation of A/C system which could alter data.

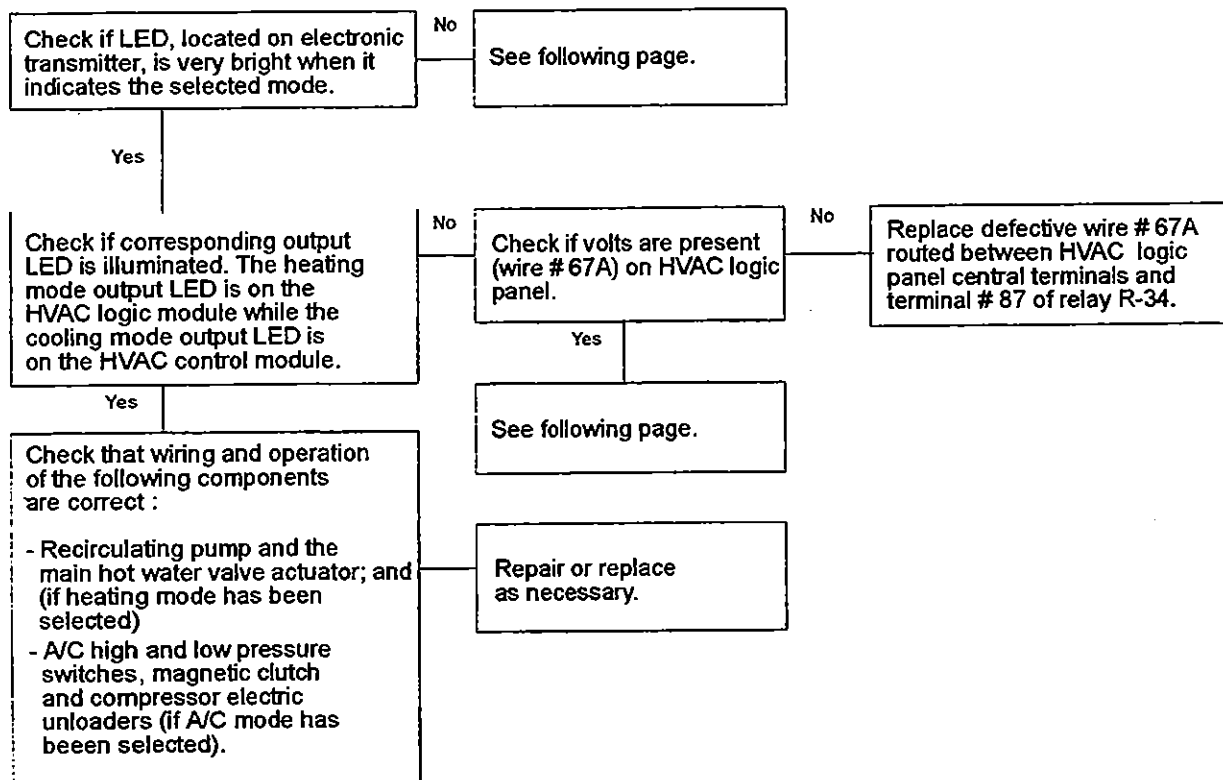

Diagram 2: Troubleshooting Chart - Temperature

22029

The LED located on the electronic transmitter and corresponding to the selected mode is poorly illuminated or not illuminated

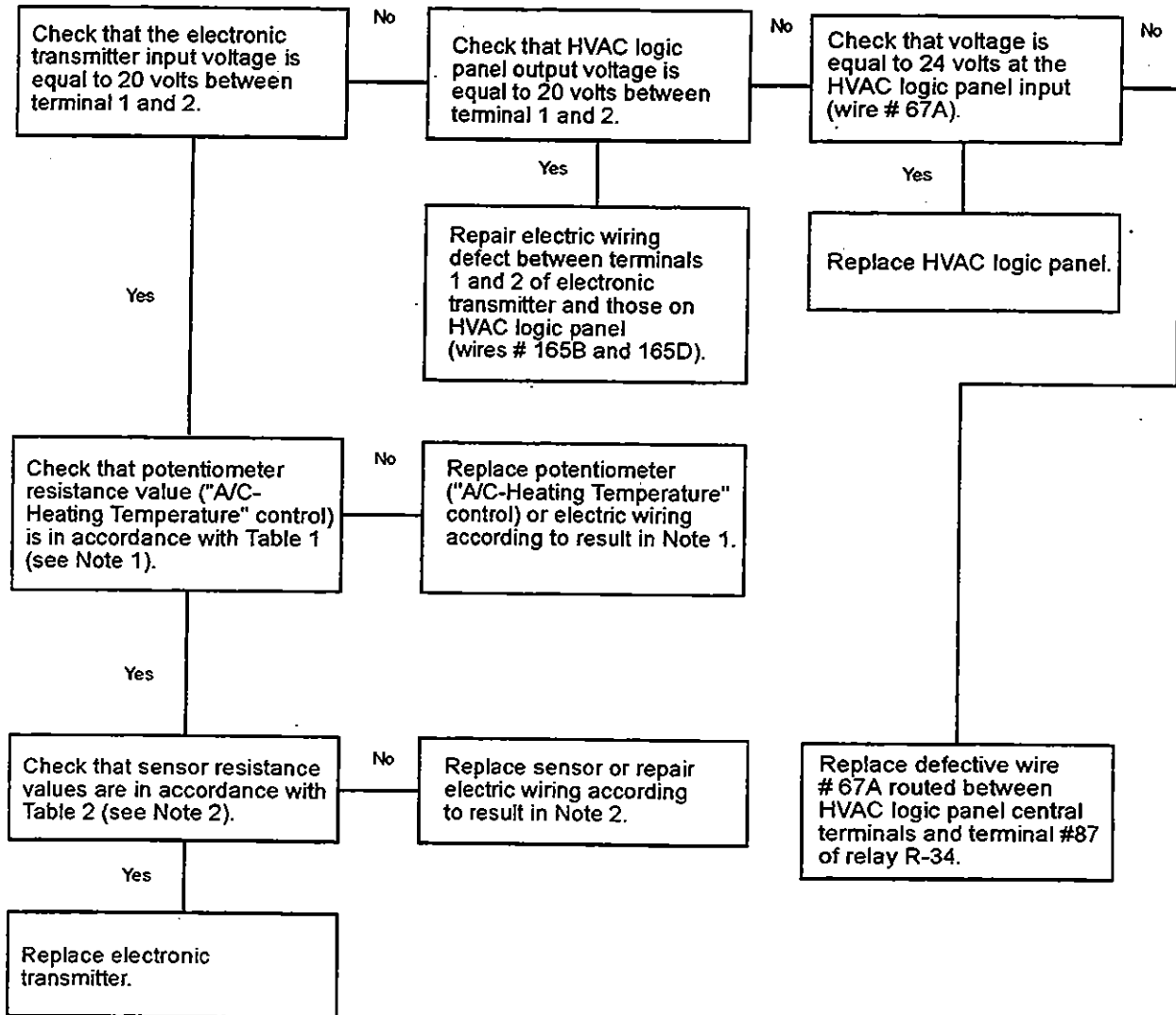

Diagram 3: Troubleshooting Chart - Electronic Transmitter

22030



## 6.2 Checking Potentiometer Resistance Values

Disconnect the 2-pin connector C-137 located on the A/C and heating junction box sliding drawer in back of the electronic transmitter. Locate the corresponding female contact pins for wires #167 and #167A, and using an ohmmeter connected according to the indications given in Table 1, check if readings match with data of Table 1. At location #165D, place the ohmmeter probe on head of screw #1 of electronic transmitter.

**Note:** *Readings may be slightly higher than those in Table 1 due to the length of the wires routed between the electronic transmitter and the potentiometer.*

If reading does not match, proceed as follows to check if potentiometer or wiring between potentiometer and electronic transmitter is defective:

Disconnect the 3-pin connector C-355 located under the dashboard, right behind the potentiometer. Identify male contact pins corresponding to the green, brown, and pink wires from potentiometer. Using an ohmmeter connected according to the indications given in Table 1 (refer to the following cross-reference between wire color and wire number), check if readings match with data of Table 1.

If readings match, trouble is located in wiring between connector C-355 and electronic transmitter. If reading does not match, potentiometer is defective.

WIRE COLOR & REFERENCES	NUMBER CROSS REFERENCES
Between connector C-355 and potentiometer	Between connector C-355 and electronic transmitter
Green	165D
Brown	167A
Pink	167

## 6.3 Checking the Sensor Resistance Values

Remove the eight screws (#1 to #8) on the electronic transmitter and move it away from its support which holds the junction terminals. Locate terminals #6 and #7 on support, and using an ohmmeter, note the reading between these two terminals. (The board is moved away from its support to isolate the sensor electric circuit from the electronic transmitter. Compare reading with data of Table 2 given in the "Recirculated Air Sensor" curve. Temperature at the bottom of Table 2 is the temperature picked up by the sensor at the time of verification.

Reading between terminals 6 and 7 corresponds to the total resistance of the four paralleled series sensors. Thus, if reading does not match with Table 2, check if problem is located at sensors or wiring.

## 6.4 Testing Each Sensor

Disconnect each connector from its respective sensor (refer to Fig. 2 for sensor location), then with an ohmmeter, note each sensor reading.

**Note:** *To gain access to the sensor connector located in the last entrance step riser, remove the six screws retaining grill; the grill, the four bolts securing the sensor mounting plate to the air return duct, then lift the sensor mounting plate.*

Compare each reading with data of Table 2 given in the "Recirculated Air Sensor" curve. The four-sensor curves are used again, since each sensor, taken individually, has the same resistance as the four paralleled series sensors taken together. If all sensors check good, the problem is located in wiring between terminals 6 and 7 and the sensors.

## CIRCUIT DIAGRAM OF DUAL POTENTIOMETER (A/C-HEATING TEMPERATURE CONTROL)

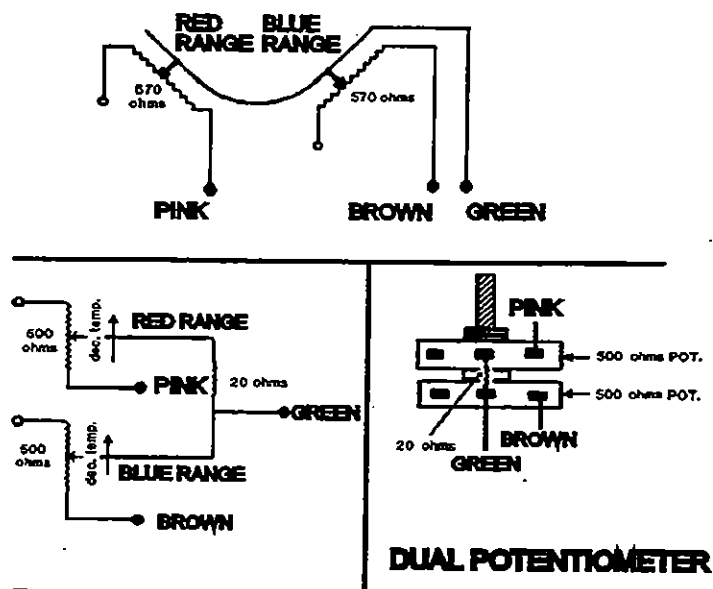

WIRE CONNECTIONS		POTENTIOMETER RESISTANCE			
SELECTED TEMPERATURE		165D / 167		165D / 167A	167A / 167
heating	cooling				
Min.	Max.	534 ohms	19 ohms	515 ohms	1046 ohms
↓ Max.	↑ Min.	493	20	473	964
		426	24	402	825
		352 ohms	27 ohms	325 ohms	673 ohms
		284	32	252	532
		210	34	176	383
		143 ohms	39 ohms	104 ohms	243 ohms
		76	45	31	103

Table 1

Section 22: HEATING AND AIR CONDITIONING

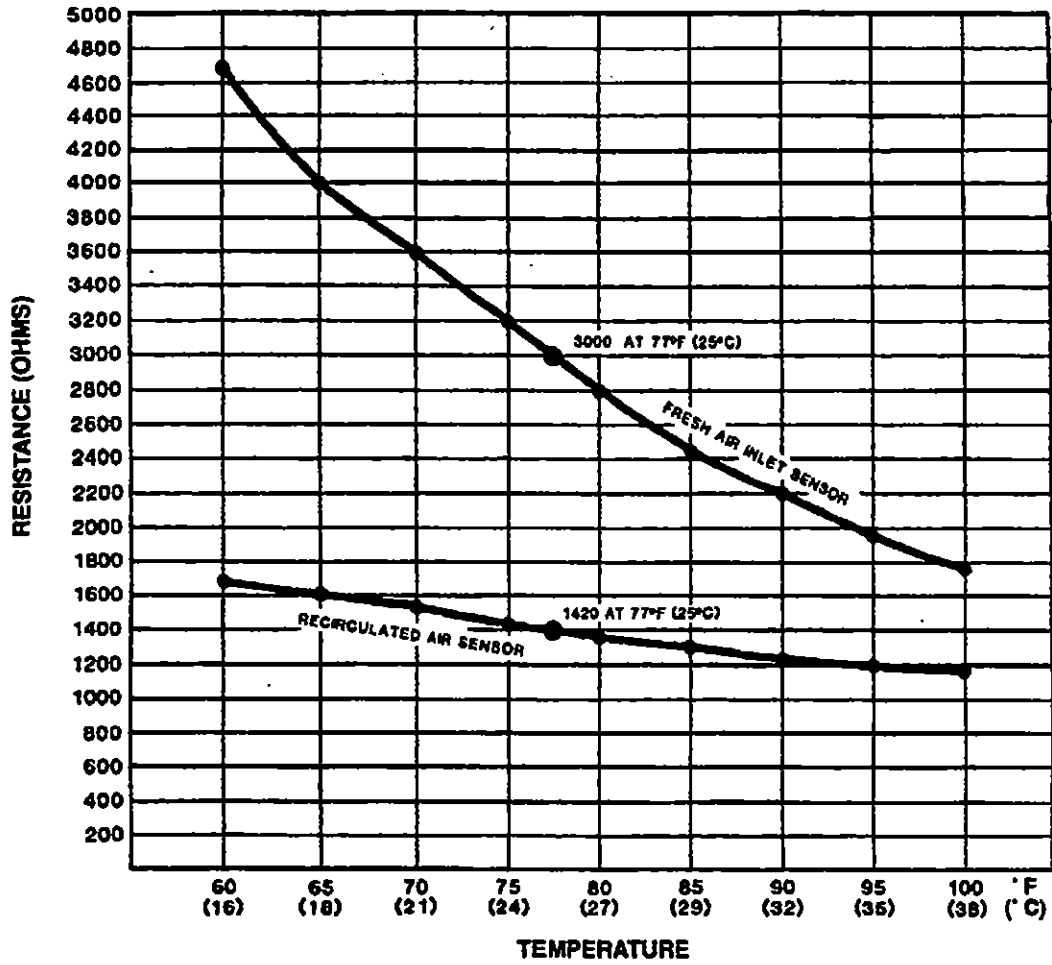

Table 2: Resistance Range According to Ambient Temperature Sensors

22032

## 6.5 Fresh Air Inlet Sensor

### 6.5.1 Description

The main HVAC is provided with a fresh air sensor located in the fresh air damper. The fresh air sensor consists of a thermistor sensing element mounted in a tubular probe. The negative temperature coefficient characteristic of the thermistor element causes its resistance to decrease as the sampled air temperature increases. The fresh air sensor provides heating and cooling anticipation to the system at a sensitivity ratio of 25:1. In other words, a 25°F (14°C) increase in fresh air inlet temperature corresponds to a 1°F (0,6°C) decrease in set temperature. Thus, if sensor is short-circuited or in an open circuit condition, the control system will be slightly affected, i.e. the temperature inside of vehicle will be about 2 or 3 °F (1 or 2 °C) lower or higher than the temperature selected by the driver with the "Main A/C - Heating Temperature" control.

### 6.5.2 Checkout

1. Set the ohmmeter scale to R X 1000.
2. At the HVAC logic panel located on the A/C and heating junction box sliding drawer, disconnect wiring terminal "T1" from sensor outlet.
3. Connect a wire of the ohmmeter to terminal "T" of HVAC logic panel, and the other wire of the ohmmeter to the loose wire of sensor.
4. The ohmmeter reading will vary according to the temperature picked up by the sensor. The fresh air inlet sensor resistance must vary between 1600 and 4800 ohms. Refer to Table 2 for the resistance readings at different temperatures. If reading does not match with the data of Table 2, disconnect wiring connector directly from fresh air sensor which is accessible from the evaporator compartment, then measure resistance of the fresh air sensor to determine if sensor or its wiring between

sensor and HVAC logic panel are defective.

## 7. HVAC UNIT MAINTENANCE

No special maintenance is required on the main and driver's units, with the exception of cleaning their respective coil air filters.

**Note:** *Squeeze rubber hose located under the concerned compartment, to eliminate water and dirt when you make routine maintenance.*

### 7.1 Coil Cleaning

Check the external surface of the coil at regular intervals for dirt or any foreign matter.

For the driver's HVAC unit, flush the coil from inside (Fig. 13) , and for the evaporator, back flush the coil (Fig. 11 ) every 12,500 miles (20 000 km) or once a year, whichever comes first.

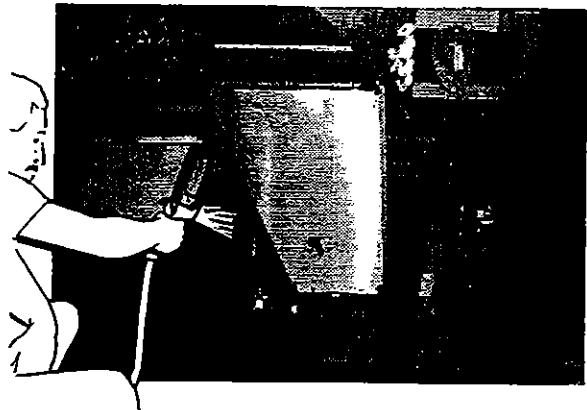

Figure 11: Evaporator Coil

22033

For the condenser coil, back flush the coil (Fig. 12) every 6,250 miles (10 000 km) or twice a year, whichever comes first.

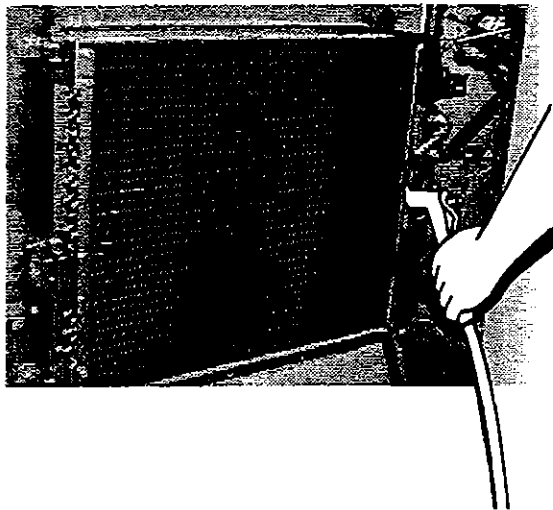

Figure 12: Condenser Coil 22034

Use a water jet or water mixed with air pressure to clean the coil.

**Caution:** Direct the pressure straight through the coil to prevent bending of fins and do not use extremely high pressure. Do not use hot water, steam or caustic soap.

## 7.2 Driver's HVAC Unit Air Filter

The air filter is located under the dashboard (Fig. 13). To gain access, unscrew both 3/4 turn knurled fasteners of A/C & heating units access panel located over entrance door steps counterclockwise. Remove panel and filter. To clean filter, back flush with water, then dry with air, every 12,000 miles (20 000 km) or once a year, whichever comes first.

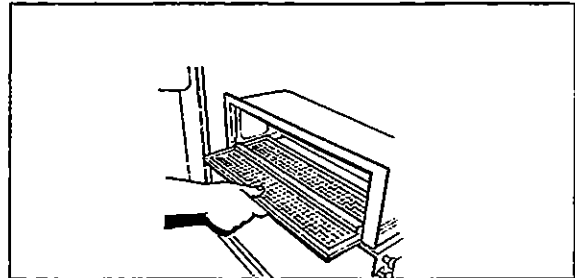

Figure 13: Driver's HVAC Unit Air Filter MAXE2209

## 7.3 Main HVAC Unit Air Filter

The main air filter is located in the HVAC compartment (Fig. 14). To access the filter, locate access panels in one of the baggage compartments adjacent to the HVAC compartments (L.H. side). Open panels by unscrewing the three screws of either panel 1/4 of a turn, unsnap both fasteners on top of filter, and slide out filter. To clean filter, back flush with water or soapy water, then dry with air every 12,000 miles (20 000 km) or once a year, whichever comes first.

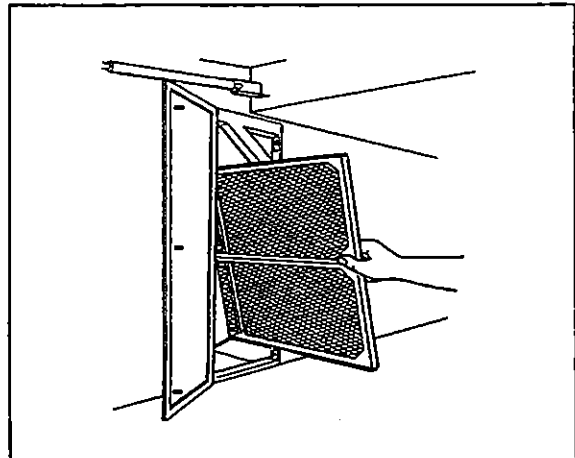

Figure 14: Main HVAC Unit Air Filter MAXE2207

**Caution:** Do not use high pressure water jet to avoid damaging filter.

**Caution:** Be sure not to reverse filter upon installation.

## 8. EVAPORATOR MOTOR

The evaporator motor is installed in the HVAC compartment (L.H. side of vehicle) (Fig. 15). It is a 27.5 volt, 2 HP (1,5 kW) motor which activates a double blower fan unit. An evaporator motor speed controller is installed in the HVAC compartment as standard equipment.

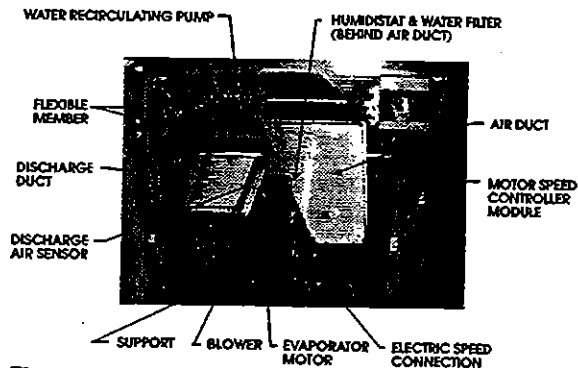

Figure 15: HVAC Compartment

22035

### 8.1 Removal

1. Set the main battery disconnect switch to the "OFF" position.
2. Open the last L.H. side baggage compartment door. Pull the black release button located on the L.H. side in order to unlock and open the HVAC compartment door.
3. Identify the L.H. side discharge duct inside compartment and remove the Phillips head screws retaining the flexible member to duct. Separate the adhesive tape (68-0453) on the duct.
4. Repeat step 3 for the R.H. side discharge duct.
5. Disconnect the discharge air sensor connector. Remove the cable tie securing wire.
6. Disconnect electrical speed connection control on the motor plate.

7. From under the vehicle, remove the eight bolts retaining the evaporator fan motor support. Remove the complete unit from the HVAC compartment (Fig. 16).
8. On a work bench, unscrew the fan square head set screws, the Phillips head screws retaining cages to support and slide out the assemblies from the evaporator motor output shaft.

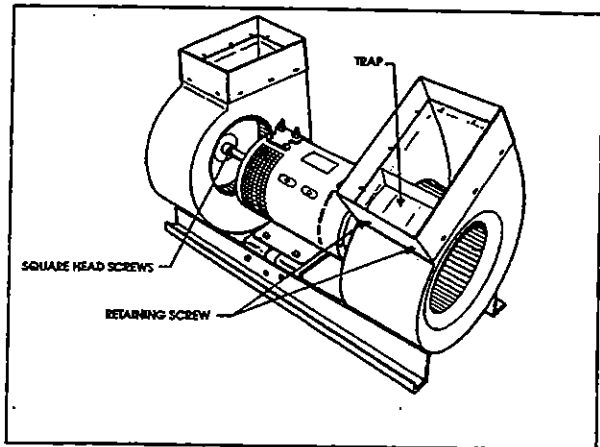

Figure 16: Evaporator Motor Assembly

22036

**Caution:** Never support evaporator motor by its output shafts while moving it.

### 8.2 Installation

To reinstall the evaporator motor, reverse "Evaporator Motor Removal" procedure.

### 8.3 Maintenance

#### 8.3.1 Checking Operation of Brush in Holder

Lift brush slightly 1/8 inch (3 mm) and release it. Brush must produce a dry noise.

## Section 22: HEATING AND AIR CONDITIONING

### 8.3.2 Brush Wear Inspection and Replacement

Replace the brushes if less than  $\frac{3}{4}$  inch (19 mm). New brush length is 1- $\frac{1}{4}$  inch. Clean brushes with a clean cloth impregnated with gasoline or alcohol.

**Warning:** *Cleaning products are flammable and may explode under certain conditions. Always handle in a well ventilated area.*

To replace brushes, proceed as follows:

1. Set main battery disconnect switch(es) to the "OFF" position.
2. Remove the protective screen band from the motor housing by pulling down the spring loaded fastener.
3. Remove and replace brushes as per the standard procedure.
4. Reverse installation procedure.

### 8.3.3 Checking Commutator

The surface must be polished. A brown-black colored surface is normal and indicates a good switching. Ensure there is no evidence of arcing or metal chips.

## 8.4 Speed Controller Module

The optional evaporator motor speed controller module is mounted on the R.H. side wall inside the HVAC compartment (Fig. 15). The purpose of this electronic module is to limit the evaporator motor speed to 70% of its full rated speed throughout the heating mode and during the first stage of the cooling mode. The module will then gradually increase the motor speed as the cooling demand increases.

### 8.4.1 Troubleshooting

Check that evaporator motor is in good condition. Perform the following test in order to determine if speed controller module is defective, or if HVAC logic panel is sending a bad signal to the module.

1. Locate the HVAC logic panel mounted on the A/C and heating junction box sliding drawer compartment as illustrated in Figure 3.
2. Disconnect the "WC" wire from the HVAC logic panel "WC" terminal.
3. Connect an ammeter between the "WC" terminal on the HVAC logic panel and "WC" wire previously disconnected.
4. The ammeter should indicate 0 mA when "A/C & Heating temperature" control is turned to the maximum heating position, and approximately 4.85 mA when it is turned to the maximum cooling position. If not, check ground continuity on speed controller module as follows.
5. Set the "A/C & Heating" switch to the "OFF" position. Connect an ohmmeter between the large and small "-" (ground) terminals on speed controller module.
6. The ohmmeter should indicate less than 5 ohms. If more, the internal ground circuit is defective and can be corrected by installing a jumper wire (18 AWG) between the two "-" (ground) terminals.
7. With the "A/C & Heating" switch set to the "ON" position, repeat steps 3 and 4. If readings still do not check within tolerance, replace speed controller module.
8. Connect a voltmeter between the "Motor" and "-" (ground) large terminals on speed controller module.
9. The voltmeter should indicate approximately 7.5 V when "A/C & Heating Temperature" control is turned to the maximum heating position, and approximately 0.5 V when it is turned to the maximum cooling position. If not, the speed controller module is defective and must be replaced as a unit.

## 9. AIR CONDITIONING SYSTEM

### 9.1 Description

The schematic of Figure 17 shows the A/C system and its components. The system is equipped with a 6 cylinder, 05G-134A Carrier compressor. The air conditioning capacity is 9 tons. The receiver and filter dryer are mounted inside the A/C condenser compartment. The fuel filler door is a small door located at left of A/C condenser compartment door, allowing viewing of the filter dryer and the moisture indicator.

**Note:** For opening of the A/C condenser door, close the baggage compartment door at the left of the A/C condenser compartment door, but do not close the fuel filler door.



Section 22: HEATING AND AIR CONDITIONING

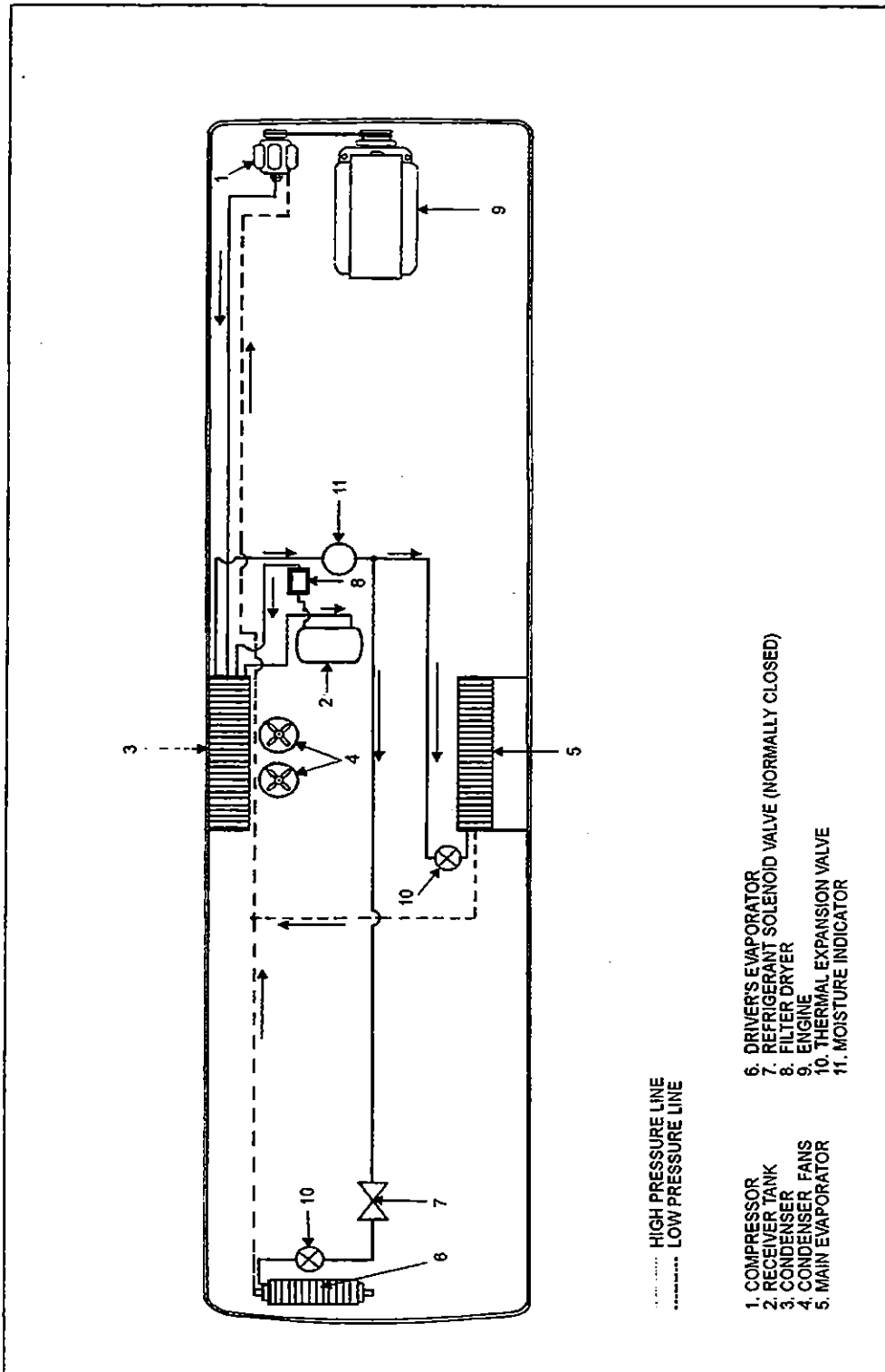

Figure 17: A/C System Components

22037

## 9.2 A/C Cycle

Refrigeration may be defined as "the transfer of heat from a place where it is not wanted to a place where it is unobjectionable". Components required for a closed circuit refrigeration system are shown in Figure 17.

The air conditioning system in the H3 series vehicles is the "Closed" type system using R-134a.

1. The refrigerant flowing to the compressor, is compressed to high pressure and reaches a temperature higher than the surrounding air. It is passed through the air-cooled fins and tubes of the condenser coil causing the hot, high pressure gas to be condensed into a liquid form.
2. The liquid refrigerant flows to the receiver tank, then through a filter dryer where all moisture, acids and dirt are removed. It is passed again into the condenser sub-cooling and through a moisture indicator which indicates if any moisture is present in the system.
3. By its own pressure, the liquid refrigerant flows through a thermal expansion valve where the pressure drop vaporizes in a vapor-liquid state at a low temperature pressure.
4. The cold low pressure refrigerant passes through the main and the driver's evaporator absorbs heat from the air passing over the fins and tubes, and changes into gas. In this form, the refrigerant is drawn into the compressor to repeat the air conditioning cycle.

The success of the air conditioning system depends on retaining the conditioned air within the coach. All windows and intake vents should be closed. An opening of approximately 8 in<sup>2</sup> (203 mm<sup>2</sup>) could easily neutralize the total capacity of the system.

Other causes of inadequate cooling are dirty coils or filter. Dirt acts as an insulation and is also serves as a restriction to the air flow.

The refrigeration load is not constant and varies. It is also affected by outside temperature, relative humidity, passenger load, compressor speed, the number of stops, etc.

The compressor will load depending on operating conditions.

## 9.3 Refrigerant

The A/C system of this vehicle has been designed to use Refrigerant 134a as a medium. Regardless of the brand, only R-134a must be used in this system. The chemical name for this refrigerant is Ethane, 1, 1, 1, 2-Tetrafluoro.

**Warning:** *Refrigerant in itself is nonflammable, but if it comes in contact with an open flame, it will decompose.*

### 9.3.1 Procurement

Refrigerant is shipped and stored in metal cylinders. It is serviced in 30 and 100 pound (13,6 and 45 kg) cylinders. Approximately 25 pounds (11,4 kg) are used in the system.

It will be impossible to draw all the refrigerant out of the cylinder. However, the use of warm water when charging the system will assure the extraction of a maximum amount of refrigerant from the cylinder.

### 9.3.2 Precautions in Handling Refrigerant

1. Do not leave a cylinder of refrigerant uncapped.
2. Do not subject the cylinder to high temperatures.

## Section 22: HEATING AND AIR CONDITIONING

3. Do not weld or steam clean on or near the system.
4. Do not fill a cylinder completely.
5. Do not discharge vapor into an area where a flame is exposed.
6. Do not expose the eyes to liquid refrigerant.

All refrigerant cylinders are shipped with a heavy metal screw cap. The purpose of the cap is to protect the valve and safety plug from damage. It is a good practice to replace the cap after each use of the cylinder for the same reason. If the cylinder is exposed to the sun's radiant heat, pressure increase resulting may cause release of the safety plug or the cylinder may burst.

For the same reason, the refrigerant cylinder should never be subjected to excessive temperature when charging a system. The refrigerant cylinder should be heated for charging purposes by placing it in 125°F (52°C) water. Never heat above 125°F (52°C) or use a blowtorch, radiator, or stove to heat the cylinder.

Welding or steam cleaning on or near any refrigerant line or components of the A/C system could build up dangerous and damaging pressures in the system.

If a small cylinder is ever filled from a large one, never fill the cylinder completely. Space should always be allowed above the liquid for expansion. Weighing cylinders before and during the transfer will determine the fullness of the cylinders.

**Warning:** *One of the most important precautions when handling refrigerant consists in protecting the eyes. Any liquid refrigerant which may accidentally escape is approximately -40°F (-40°C). If refrigerant comes in contact with the eyes, serious injury could result. Always wear goggles to protect the eyes when opening refrigerant connections.*

### 9.3.3 Treatment in Case of Injury

If liquid refrigerant comes in contact with the skin, treat the injury as if the skin was frost-bitten or frozen.

If liquid refrigerant comes in contact with the eyes, consult an eye specialist or doctor immediately. Give the following first aid treatment:

1. Do not rub the eyes. Splash eyes with cold water to gradually bring the temperature above the freezing point.
2. Apply drops of sterile mineral oil (found at any drugstore) in the eyes to reduce the possibility of infection. The mineral oil will also help in absorbing the refrigerant.

### 9.3.4 Precautions in Handling Refrigerant Lines

1. All metal tubing lines should be free of kinks, because of the restriction that kinks will give to the flow of refrigerant. The refrigeration capacity of the entire system can be greatly reduced by a single kink.
2. The flexible hose lines should never be allowed to come within a distance of 2-1/2 inches (6,3 cm) of the exhaust manifold.
3. Use only sealed lines from parts stock.
4. When disconnecting any fitting in the refrigeration system, the system must first be discharged of all refrigerant. However, proceed very cautiously, regardless of gauge readings. If there happens to be liquid refrigerant in the line, disconnect fittings very slowly, keeping face and hands away so that no injury can occur. If pressure is noticed when fitting is loosened, allow it to bleed off very slowly.

**Warning:** *Always wear safety goggles when opening refrigerant lines.*

## Section 22: HEATING AND AIR CONDITIONING

5. In the event that any line is opened to the atmosphere, it should be immediately capped to prevent entrance of moisture and dirt.
6. The use of the proper wrenches when making connections on O-ring fittings is important. The use of improper wrenches may damage the connection. The opposing fitting should always be backed up with a wrench to prevent distortion of connection lines or components. When connecting the flexible hose connections, it is important that the swaged fitting and the flare nut, as well as the coupling to which it is attached, be held at the same time using three different wrenches to prevent turning the fitting and damaging the ground seat.
7. The O-rings and seats must be in perfect condition. The slightest burr or piece of dirt may cause a leak.
8. O-rings should be coated with refrigeration oil and installed on the line before the line is inserted into the fitting to prevent damaging the O-ring. If leaks are encountered at the couplings or connectors, no attempt should be made to correct the leaks by tightening the connections beyond the recommended torque. The O-rings are designed to seal at the specified torque and overtightening the connection does not result in a satisfactory and permanently sealed connection. The connection must be disassembled and the cause of the leak (damaged O-ring, defective lines, etc.) corrected. Use new O-ring.

### 9.4 Pumping Down

This procedure is intended to reduce refrigerant loss by isolating it in the compressor and the receiver tank, as well as in their connecting line, in order to carry out repairs on other sections of the air conditioning system (lines and components).

**Note:** Before attempting any repair between compressor and receiver tank, use a recovery unit to remove refrigerant from the system.

**Warning:** When air conditioning system must be opened, refer to previous paragraph "PRECAUTIONS IN HANDLING REFRIGERANT" to prevent any injury.

#### Procedure

1. Close the receiver tank outlet valve by turning it clockwise, backseat the suction service valve on the compressor, install an appropriate pressure gauge set, and turn the valve forward 1/4 turn to enable a visual check of the suction pressure.
2. Disconnect the "Low Pressure Switch" connector (mounted near the A/C compressor), and install a jumper wire.

**Note:** This jumper wire will allow the clutch to remain engaged after pressure drops below 15 psi (103,5 kPa).

3. Open the baggage compartment located at the right of the HVAC compartment door, unscrew the retaining screw on back wall of the compartment a quarter of a turn. Slide the "A/C and Heating Junction Box Sliding Drawer". Locate the **cooling contact 3** on the HVAC logic panel. Install a jumper wire between the central terminal of this stage and its normally-closed contact terminal as illustrated in Fig. 18. Locate the **cooling contact 2**. Install a jumper wire between the central terminal of this stage and its normally-closed contact terminal as illustrated in Fig. 18.

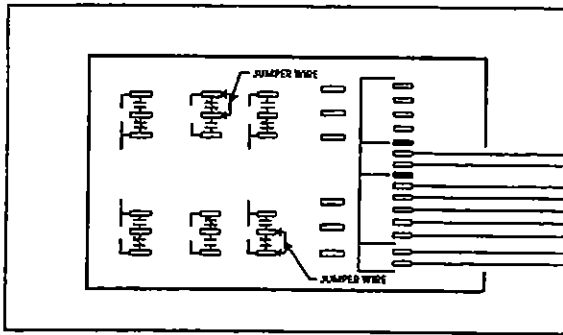

Figure 18: HVAC Logic Panel

22038

**Note:** No wire has to be disconnected. In fact, wires #31A and 31B will be connected to wire #67A. This temporary connection will restrict compressor operation to two cylinders.

4. Start the engine, turn on the "Main A/C-Heating" switch, and adjust "A/C-Heating Temperature" controls to maximum A/C position.
5. Run the compressor until pressure reaches 1-2 psi (7-14 kPa).

**Note:** During this operation, care must be taken not to fill the receiver tank over the upper sight glass. If so, stop process immediately. Always allow refrigerant piping and units to warm up to the ambient air temperature before opening system or sweating will take place inside the lines.

6. Stop engine, and close compressor outlet valve by turning it clockwise until valve is properly seated.
7. Close compressor suction valve by turning it clockwise until it is properly seated.

## 9.5 Adding Refrigerant (Vapor State)

Use the suction service valve on the compressor to add a small quantity of refrigerant to the system. Backseat the valve and connect a charging line from the refrigerant cylinder to the valve loosely. Tighten connection at level of refrigerant cylinder and open tank end slightly to purge air from the charging line. Tighten the charging line at the compressor. Screw in the stem of suction valve approximately two turns. Start the engine and run at fast idle. Add sufficient refrigerant to bring the level in lower sight glass of receiver tank to mid-point. Always charge the system with the cylinder upright and the valve on top to avoid drawing liquid out of the cylinder.

Fill liquid refrigerant at the receiver tank and completely charge, if necessary, using previous procedure.

## 9.6 Evacuating System

1. Open both receiver valves by turning "out" (normal position).
2. Remove the caps from the two 90° adapters on the suction, discharge valves and connect two hoses to the vacuum hose.
3. Place the two compressor valves, suction and discharge, in neutral position by turning each one 3 to 4 turns "in" from the "out" position.
4. Start the vacuum pump. Open the large (suction) shutoff valve and close the small vacuum gauge valve.
5. The pressure will drop to approximately 29 inches vacuum (14.2 psi or 97,9 kPa) (the dial gauge only gives a general idea of the absolute system pressure).
6. Backseat the compressor valves by turning "out" all the way.

## Section 22: HEATING AND AIR CONDITIONING

7. Shut down the vacuum pump.
8. Remove the hoses.
9. Reinstall the caps at the suction valve take-off points.

### 9.7 Charging System

When a system has been opened or if there are any questions about the air or moisture in the system, evacuate the system. Charging of an evacuated system may be accomplished by forcing liquid R-134a directly into the receiver tank.

When charging an empty system, weigh the amount of refrigerant put into the system. This will eliminate any possibility of overfilling. A full charge requires 24 pounds (10,9 kg).

1. Backseat the two compressor shutoff valves ("out").
2. Install the test gauges at the shutoff valves noting that the 400 psi (2758 kPa) gauge is connected to the discharge.
3. Turn in the two shutoff valves 3 to 4 turns.
4. Open the lower receiver valve by turning "out" all the way.
5. Backseat the upper receiver valve by turning out all the way.
6. Remove the cover cap from the service fitting in the top receiver valve.
7. Attach a charging hose to the R-134a tank. Open the tank valve slightly permitting R-134a to escape thus purging the hose of air.
8. Connect the charging hose to the service fitting.
9. Open the R-134a tank valve.

10. To build up pressure in the receiver tank, heat the receiver tank with a heating blanket.
11. Turn in the upper receiver valve several turns. The R-134a will now enter the system.
12. The proper charge of R-134a is 24 lbs (10.89 kg). When the scale indicates this amount of charge, backseat the receiver valve and close the R-134a tank valve.
13. Disconnect the charging hose. Replace the cover caps.
14. The system is now ready for operation.

**Caution:** *The evacuation of the system must be made by authorized and qualified personnel only. Refer to local laws for R-134a recuperation.*

### 9.8 Refrigerant System Cleanout After Compressor Failure

Although the vast majority of reciprocating refrigerant compressors manufactured today are extremely reliable, a small percentage do fail. These failures usually result in minor or extensive system contamination depending on the severity of the failure. When an open type compressor becomes damaged internally, this provokes small particles of bearings, steel, brass, copper, and aluminium and, in severe cases, carbonized oil, which could contaminate the system. To prevent repeated failures, the problem which caused the failure should be corrected, and depending upon the severity of the failure, the system should be thoroughly cleaned out using one of the cleanout procedures mentioned.

### **9.8.1 Determining Severity of Failure**

The severity of compressor failure can be categorized as minor or major. A failure is considered minor when the contamination is limited to the compressor with little or no system contamination. A major failure, or burnout, results in extensive system contamination as well as compressor damage. Extensive system contamination can be determined by withdrawing a small sample of compressor oil and checking its color, odor and acidity. A Virginia Chemical "TKO" one step acid test kit is one of several compressor oil test kits that may be used. A high acid content would indicate a major failure or burnout. A small amount of refrigerant gas may be discharged. A characteristic burned odor would also indicate severe system contamination.

### **9.8.2 Cleanout after Minor Compressor Failure**

1. Be sure to correct the problem which caused the failure.
2. Change liquid line filter dryer.
3. Run the unit for hours on high speed cool only. If a unit with a hot gas heating system is allowed to operate in heat or defrost, the refrigerant will not all flow through the liquid line filter dryer for cleaning and some parts of the system which were not previously contaminated, may become contaminated.
4. Check compressor oil level to ensure compressor is not overcharged with oil. Sometimes a significant amount of oil is pumped out of the compressor to other parts of the system when a compressor fails. This oil will return to the replacement compressor when it is started, causing an overcharge of oil in the sump of the replacement compressor. In this case, it is important that the oil level be adjusted to the proper level.
5. Withdraw a sample of the compressor oil and check its color, odor, and acidity, using instructions supplied above. If the oil is contaminated, change the oil and filter dryer, and repeat the procedure until the system is clean.

### **9.8.3 Cleanout After Major Compressor Failure**

1. Reclaim the refrigerant into a refrigerant bottle through a filter dryer to filter out contaminants.
2. Remove the failed compressor and repair it if possible.
3. Install new or repaired compressor.
4. Change the filter dryer.
5. Circulate clean R-134a with the reclaimer to clean out many of the contaminants collected in the coil valves, TXV (Thermal Expansion Valve), solenoid valves, check valves, and any other mechanical component that may have collected contaminants.
6. Evacuate and charge the system normally.
7. Run the unit for 8 hours and monitor the pressure drop across the filter dryer. Also check the liquid line dryer for signs of restriction. If the pressure drop across the filter dryer exceeds 12 to 14 psig (82,75 to 96,5 kPa) with a 40°F (5°C) evaporator coil temperature, stop the unit and change the liquid line and suction line filter dryer. After 4 or 5 hours of operation, stop the unit and replace the filter dryer.
8. After 8 hours of operation, stop the unit and remove a sample of the compressor oil and check its color, odor, and acidity, using instructions supplied above. If the oil is contaminated, replace the oil and repeat step 7. If the oil is not contaminated, change the filter dryer again and replace the moisture-liquid indicator.

9. After approximately 7 days of operation, recheck the compressor oil for cleanliness and acidity.

## 10. A/C SYSTEM COMPONENTS

### 10.1 Compressor (Central System)

#### 10.1.1 Belt Replacement

**Warning:** Set the main battery disconnect switch to the "Off" position. For greater safety, set the engine starter selector switch in engine compartment to the "Off" position.



Figure 19: Engine Compartment Rear Door 05035

1. Locate the belt tensioner two-way control valve (Fig. 19), and turn handle counter-clockwise in order to release pressure and tension on belts.
2. Slip the old belts off and the new ones on.

**Note:** Both belts must always be replaced simultaneously to ensure an equal distribution of load on each of them.

3. Reset belt tensioning pressure control valve to 50 psi (345 kPa) to apply tension on the new belts as explained in Section 12.

#### 10.1.2 Pulley Alignment

In order to avoid skipping, disengagement and a premature wear of compressor belt, it is necessary to align compressor pulley with the crankshaft pulley. Before performing the following procedure, release air from belt tensioners by means of the two-way control valve. After completing these procedures reset belt tensioning pressure control valve to 50 psi (345 kPa).

#### 10.1.3 Longitudinal Compressor Alignment

1. Rest an extremity of a straight edge of approximately 46 inches (117 cm) against the upper part of the outer face of crankshaft pulley, positioning the other end close to the compressor clutch pulley (Fig. 20 and 21).
2. Check the distance between each extremity of straight edge (1. Fig. 21) and the first drive belt. If they are different, loosen the compressor support bolts and with a hammer, knock support to slide it in order to obtain the same distance, and tighten the bolts.

#### 10.1.4 Horizontal Compressor Alignment

1. Rest an extremity of the straight edge against the upper part of the outer face of compressor pulley, positioning the other end close to the crankshaft pulley.
2. Check the distance between each extremity of straight edge (1, Fig. 21) and drive belt. If they are different, loosen the pillow block compressor bolts and with a hammer, knock compressor pillow block to slide it in order to obtain the same distance, and tighten the bolts.



### 10.1.5 Vertical Compressor Alignment

Rest a short "angle and level indicator" on the outer side face of the crankshaft pulley, adjust the level indicator inclination at 0° and check if the compressor pulley is at same angle (Fig. 20 & 21). If it is not the same, shim under the appropriate pillow block in order to obtain a correct angle.

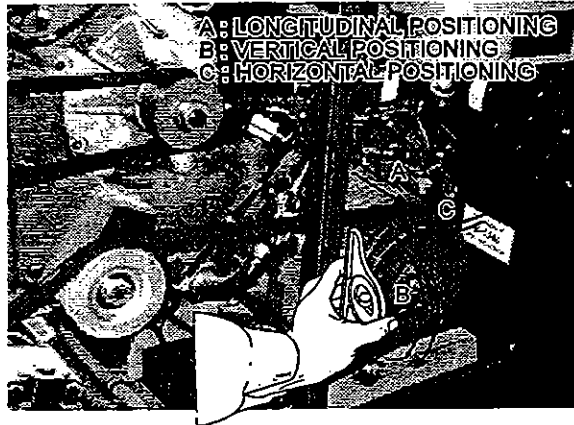

Figure 20: Compressor Alignment

22039

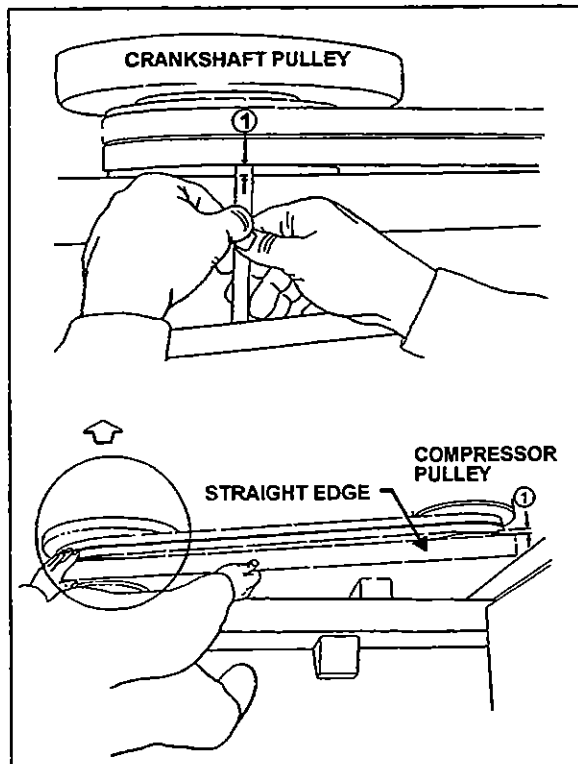

Figure 21

22040

### 10.1.6 Compressor Maintenance

For the maintenance of the A/C compressor, see the "Carrier Compressor Operation and Service Manual" included at the end of this section.

**Caution:** Use only Castrol SW 68 (POE) oils with refrigerant 134a.

### 10.1.7 Troubleshooting Guide

A preliminary check may be made by simply feeling the cylinder heads with the unit in operation at ambient temperatures of 35°F (2°C) and over. The cylinder heads are internally divided into suction and discharge valves. The lower half of the cylinder head is the suction side, and it should be relatively cool to the touch, as opposed to the hot upper discharge side. If a valve plate or head gasket is blown, or a compressor unloader is stuck open, partially compressed refrigerant vapor will be circulated between the suction and discharge sides of the head. The affected cylinder head will then have a relatively even temperature across its surface and be neither as hot as the normal discharge temperature nor as cool as the normal suction temperature.

Broken suction valves are probably the most difficult items to detect without opening the compressor. Depending on the condition of the cylinder walls and piston rings, a compressor in good condition should be able to pull a vacuum of 20 inches Hg with the suction service valve frontseated. Failure to reach this value would require disassembly of the compressor to determine actual component conditions.

#### Blown Head Gaskets

##### Symptom:

- Loss of unit capacity at low temperature.
- Even cylinder head temperature.

##### Cause:

- Improperly torqued cylinder head bolts.
- Improperly positioned gasket at assembly.
- Warped cylinder head
- Severe liquid refrigerant floodback.

### Blown Valve Plate Gaskets

#### Symptom:

- Loss of unit capacity at medium and low temperatures.
- Very hot cylinder head surface.
- Higher than normal suction pressure.

#### Cause:

- Improperly torqued cylinder head bolts.
- Severe liquid refrigerant floodback.
- Oil slugging caused by an overcharge of oil or flood starts.
- Discharge valves not seated properly (liquid drainback during shutdown).

### Broken Suction Valves

#### Symptom:

- Loss of unit capacity at all temperatures.
- Compressor unable to pull extremely low vacuum with suction service valve frontseated.

#### Cause:

- Repeated liquid refrigerant floodback.
- Flooded starts.
- Overcharge of oil.
- Discharge valves not seated properly (liquid drainback during shutdown).
- Expansion valve not controlling properly.

### Unloader Valve Stuck Open

#### Symptom:

- Loss of unit capacity at all temperatures.
- Higher than normal suction pressure.
- Even cylinder head temperature.

#### Cause:

- Unloader body stem bent.
- Foreign material binding unloader piston or plunger.

## 10.2 Magnetic Clutch

Refer to Carrier service information entitled "*Housing-Mounted Electric Clutch*" at the end of this section for the description and maintenance of the magnetic clutch.

### 10.2.1 Time Delay Module

A time delay module integrated in the HVAC logic module is connected in series with the relay coil feeder circuit of the compressor magnetic clutch. This module allows approximately one minute delay following a compressor clutch request and its actual application, to avoid continuous engaging and disengaging (cycling) of clutch.

This time delay will be effective each time A/C system is actuated (Main A/C-Heating Switch), or upon restarting of compressor, when the latter has previously stopped due to an excessive high pressure (over 320 psi [2206,4 kPa]) or very low pressure (under 15 psi [103,5 kPa]) in the system.

However, a time delay will be inoperative and restarting of the compressor will be immediate following a regulated interruption by the system, i.e. when temperature inside the coach is equal to the selected temperature.

## 10.3 Condenser

The condenser coil is hinge mounted on the R.H. side of the vehicle on the A/C condenser door. Since condenser's purpose is to dissipate heat from the hot refrigerant, it is important to keep the cooling coils and fins clean. A clogged coil will cause high discharge pressure and insufficient cooling.

### 10.3.1 Condenser Fan Motors

Two axial fan motors are installed in condenser compartment on R.H. side of vehicle in order to ventilate the condenser coil. The fans pull outside air through the condenser coil and discharge it through an opening at bottom of compartment. Depending on pressure in receiver tank (Fig. 22), the fan motors may be operated at full rpm, half rpm or not operated at all. With low pressure in receiver tank, both fan motors are connected in series and then operate at half rpm and, with a high pressure in receiver tank, both fan motors are connected in parallel and operate at full rpm. For details about electrical wiring, refer to "A/C and Heat system" in the master wiring diagram.

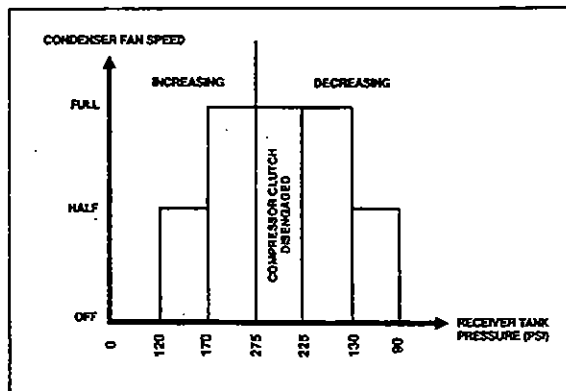

Figure 22: Condenser Fan Speed in Relation with Receiver Tank Pressure

### 10.3.2 Condenser Fan Motor Removal

1. Set the main battery disconnect switch to the "Off" position.

2. Remove the two "Phillips" head screws retaining the fan motor protective cover to the square tubing.
3. Disconnect wiring from terminals on motor. Tag each wire to aid in identification at time of reconnection.
4. Support motor, and remove bolts which attach motor to mounting bracket. Remove the motor.

### 10.3.3 Preliminary Disassembly

1. Remove the brushes.
2. Unscrew the flange retaining screws on the shaft end side (opposite to the commutator end frame), and separate flange from frame (Fig. 23).

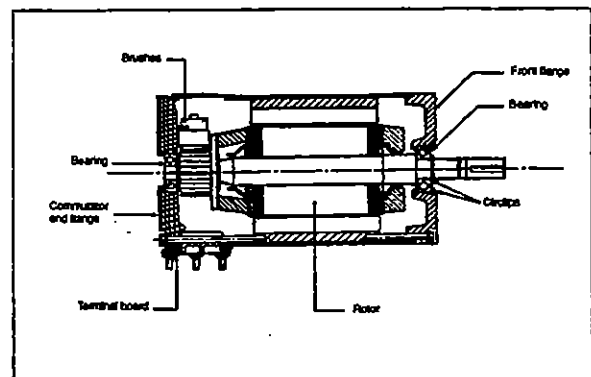

Figure 23: Condenser Fan Motor

3. Remove flange and rotor assembly by pushing bearing shaft toward the commutator end frame.
4. Separate flange from rotor.

### 10.3.4 Disassembly

1. Perform preliminary disassembly.
2. Carefully note the position of the brush holder ring and the connections on the flange support.

3. Unscrew and remove the flange on the commutator end frame.
4. Remove the brush holder ring.
5. Finally, separate the following parts: brush holders, brush boxes, terminal board, bearings, etc...

## 10.4 Receiver tank

The receiver tank is located in the A/C condenser compartment (Fig. 24). The function of the receiver tank is to store the liquid refrigerant. During normal operation, the level of the refrigerant should be approximately at the mid-point of the lower sight glass.

In case of an extreme pressure there will be a rise in the liquid receiver tank. A pressure relief valve will break at 450 psi (3103 kPa) and relieve the receiver tank pressure.

The receiver tank incorporates an inlet valve on the inlet side (upper section) which allows the tank to be isolated or serviced. An outlet valve on the outlet side (lower section) permits complete isolation from the rest of the system.

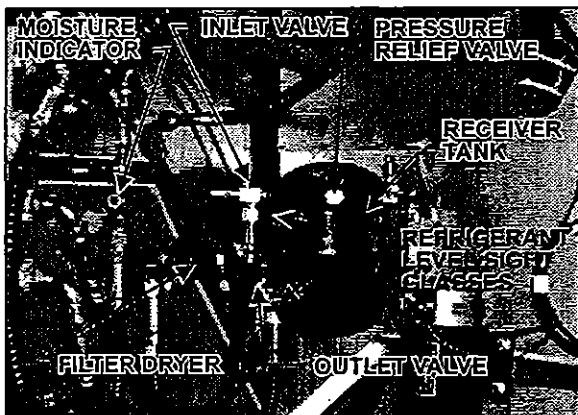

Figure 24: A/C Condenser Compartment 22043

## 10.5 Filter Dryer

### 10.5.1 Description

A filter dryer, also located in the A/C condenser compartment, is installed on the liquid refrigerant line (near the receiver tank). It is used to absorb moisture and foreign matter from refrigerant before it reaches the expansion valves.

The filter should be replaced if the system has been opened to prolonged exposure as shown by the moisture indicator sight glass.

### 10.5.2 Replacement

The filter is of the disposable type. When replacement is required, remove and discard the complete unit and replace with a new unit of the same type according to this procedure:

1. Isolate the refrigerant in the receiver tank by following the "Pumping Down" procedure stated previously.
2. Change the filter dryer as a unit.
3. Add a small quantity of refrigerant R-134a to the low side of the system. Check for leaks. Return the system to normal operation.

**Caution:** Do not use carbon tetrachloride or similar solvents to clean parts. Do not use steam guns. Use mineral spirits or naphtha. All parts should be thoroughly cleaned. Use a stiff brush to wash dirt from grooves, holes, etc.

**Warning:** Cleaning products are flammable and may explode under certain conditions. Always handle in a well ventilated area.

## Section 22: HEATING AND AIR CONDITIONING

### 10.5.3 Moisture Indicator

The moisture sensitive element consists of a color changing ring which is reversible from pink to blue and vice versa as the moisture content in the refrigerant changes. Pink indicates a wet refrigerant, light violet (caution) and blue indicates a dry refrigerant.

Since temperature changes affect the solubility, color change will also vary with the refrigerant temperature. The following table shows the color change for R-134a at various moisture levels and liquid line refrigerant temperatures.

COLOR INDICATOR			
TEMPERATURE	BLUE (ppm)	LIGHT VIOLET (ppm)	PINK (ppm)
75°F (24°C)	Below 5	5-15	Above 15
100°F (38°C)	Below 10	10-30	Above 30
125°F (52°C)	Below 15	15-45	Above 45

p.p.m.= parts per million (moisture content)

A moisture level of 15 p.p.m. for R-134a indicated in the blue color range of the above table is generally considered dry and safe. A color indication of light blue to light violet indicates the caution range of moisture level. For positive protection, the drying of the system should be continued until the color of the element turns to deep blue.

The liquid refrigerant is readily visible through the center opening of the moisture element where the presence of bubbles indicates a shortage of refrigerant or restriction in line.

Moisture is one of the main causes of chemical instability or contamination in air conditioning systems. If moisture is present, it can corrode the valves, condenser and evaporator coils, compressor and other components causing a malfunction and eventual failure of the system. Uncontrolled moisture in the system can result in very expensive multiple component replacements if not corrected at an early stage. The moisture indicator permits an early detection of moisture in the system and when corrected by a

desiccant charge, system contamination is greatly minimized.

### 10.6 Liquid Refrigerant Solenoid Valve

#### 10.6.1 Description

The flow of liquid refrigerant to the driver's evaporator is controlled by a normally-closed solenoid valve located on the ceiling of the spare wheel and tire compartment and is accessible through the reclining bumper (Fig. 17).

#### 10.6.2 Manual Bypass

This type of solenoid valve is equipped with a manual operating stem. The 3/16 inch square stem located on the bonnet is exposed when the seal cap is removed. To manually open valve, turn stem 1/2 turn counterclockwise. To manually close valve, turn stem clockwise until tight against seat. Manual stem must be in closed position for automatic electric operation.

#### 10.6.3 Coil Replacement

1. Disconnect connector from the coil connector.
2. Take out the retaining screw at the top of the coil housing. The entire coil assembly can then be lifted off the enclosing tube.
3. Place the new coil and yoke assembly on the enclosing tube. Lay data identification plate in place.
4. Insert the coil retaining screw, rotate housing to proper position and tighten screw securely.
5. Connect connector from coil connector.

### 10.6.4 Valve Disassembly

1. Remove the coil as stated previously.
2. Pump down the system as stated earlier in this section.
3. Remove the four socket head screws which hold the body and bonnet together (Fig. 25).
4. Carefully lift off the bonnet assembly (upper part of the valve) so that plunger will not fall out. The diaphragm can now be lifted out.

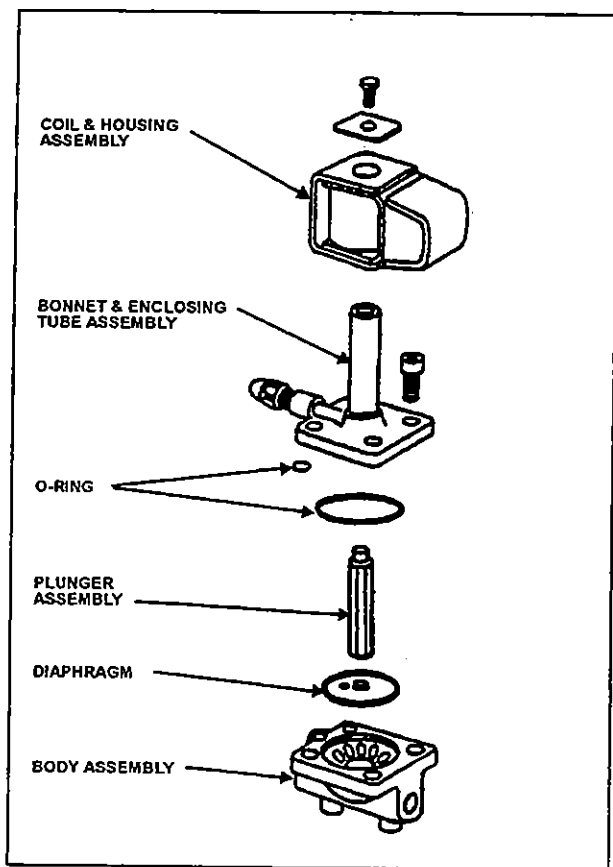

Figure 25: Refrigerant Solenoid Valve 22044

**Note:** The above procedure must be followed before brazing solder-type bodies into the line.

**Caution:** Be careful not to damage the machined faces while the valve is apart.

### 10.6.5 Valve Reassembly

1. Place the diaphragm in the body with the pilot port extension up.
2. Hold the plunger with the synthetic seat against the pilot port.
3. Make sure the bonnet O-rings are in place. Lower the bonnet assembly over the plunger, making sure that the locating sleeve in the bonnet enters the mating hole in the body.
4. Insert the four socket head screws and tighten evenly.
5. Replace the coil as stated previously.
6. Add a small quantity of refrigerant R-134a to the low side of the system. Check for leaks. Return the system to normal operation.

## 10.7 HUMIDISTAT

### 10.7.1 Description

This control, which is frequently used in houses, activates a humidifier in cases where the humidity rate of ambient air in the house is lower than the rate selected manually on the humidistat. The same control is used on this vehicle, with the exception that the inside ambient air of the vehicle must be dried when the humidity rate is too high. To do so, the signal transmitted by the humidistat is reversed by the use of the HVAC control module.

## Section 22: HEATING AND AIR CONDITIONING

---

Air is dried by activating **Cooling contact 1** on the HVAC logic panel. Thus, the humidistat is a control which enables the bypass of the A/C system control to activate the A/C compressor. In practice, this means that when the heating system is operating, the A/C system can also operate simultaneously. A yellow LED mounted on the HVAC control module will be turned on to indicate a dehumidifying request (for location, refer to previous heading "*Humidistat Yellow LED*"). The humidistat is located in the HVAC compartment, in the center of the rear wall.

**Note:** *Even if the dehumidifying function is requested, cooling contact 1 on the HVAC logic panel will not turn on as long as the ambient temperature inside the vehicle is over 4°F (2°C) from the selected temperature with "Main A/C - Heating Temperature" control.*

### 10.7.2 Setting

As a reminder, the humidistat, which is mounted in center of rear wall of the HVAC compartment, should be set to 30%. This setting allows passengers to be comfortable and furthermore avoids unnecessary loading of A/C compressor. But, in areas where during transitional seasons, the temperature fluctuates 23° and 50°F (-5° and 10°C) with a high degree of humidity, lower the the humidistat to 15% to prevent windshield fogging. Do not forget to reset humidistat to 30% once this period is over.

### 10.7.3 Checkout

1. Turn the control knob of the humidistat counterclockwise to the "Off" position.
2. Start engine, then switch on the "Main A/C-Heating" switch.
3. Turn the "Main A/C - Heating Temperature" control clockwise to its maximum heating position. The red LED located on the lower console should illuminate to indicate operation of the heating system.

4. Then, slowly turn the "Main A/C - Heating Temperature" control counterclockwise until the green LED located on the lower console also illuminates (red LED should remain illuminated) to indicate the dehumidifying request.
5. Turn the control knob of the humidistat to its maximum clockwise position; the green LED on the lower console should turn off.
6. Reset humidistat control.

### 10.7.4 Maintenance

Do not apply oil to any part of the humidistat. To ensure trouble-free performance, the nylon element should be inspected periodically. Dirt and grease will not damage the element, but may reduce its sensitivity. If necessary, remove accumulated dust and dirt with a soft bristled brush.

## 10.8 Expansion Valve

### 10.8.1 Main System

The expansion valve for the main system is a thermo-sensitive valve with a remote control bulb head attached to the evaporator outlet line and is accessible by the evaporator filter access door (Fig. 17 and 26). The valve regulates the flow of refrigerant liquid into the evaporator coils and is controlled by the suction gas temperature leaving the evaporator. The bulb head senses the refrigerant gas temperature as it leaves the evaporator. High temperature will cause expansion and pressure on the power head and spring. Such action causes the assembly valve to open, allowing a flow of refrigerant liquid into the evaporator.

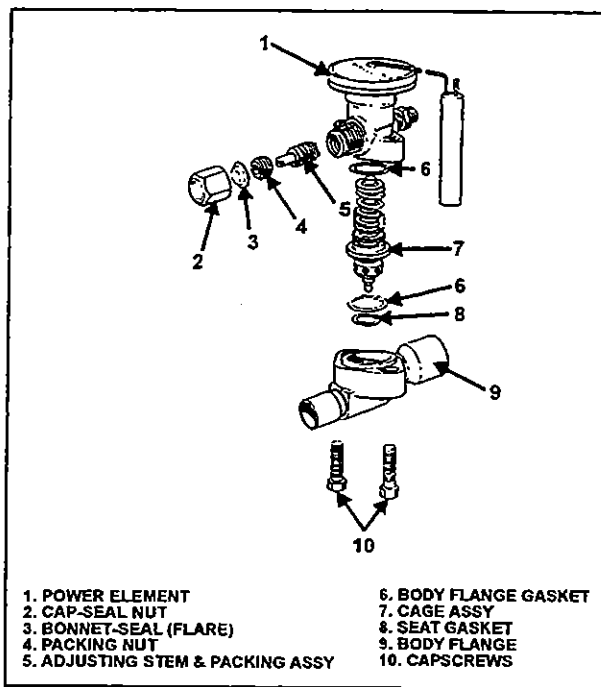

Figure 26: Expansion Valve

22045

The remote bulb and power assembly is a closed system. The pressure within the remote bulb and power assembly corresponds to the saturation pressure of the refrigerant temperature leaving the evaporator and moves the valve pin in the opening direction.

Opposed to this force, on the under side of the diaphragm and acting in the closing direction, is the force exerted by the superheat spring. As the temperature of the refrigerant gas at the evaporator outlet increases above the saturation temperature corresponding to the evaporator pressure, it becomes superheated. The pressure thus generated in the remote bulb and power assembly surpasses the combined pressures of the evaporator pressure and the superheat spring, causing the valve pin to move in the opening direction. Conversely, as the temperature of the refrigerant gas leaving the evaporator decreases, the pressure in the remote bulb and power assembly also decreases and the combined evaporator and spring pressures cause the valve pin to move in the closing position.

As the operating superheat is raised, the evaporator capacity decreases, since more of the evaporator surface is required to produce the superheat necessary to open the valve. It is obvious, then, that it is most important to adjust the operating superheat correctly and that a minimum change in superheat to move the valve pin to full open position, is of vital importance because it provides savings in both initial evaporator cost of operation. Accurate and sensitive control of the refrigerant liquid flowing to the evaporator is necessary to provide maximum evaporator capacity under load conditions. The spring is adjusted to give 8 to 12°F (-13,3 to -11,1°C) of superheat at the evaporator outlet. This ensures that the refrigerant leaving the evaporator is in a completely gaseous state when drawn into the suction side of the compressor. Liquid would damage the compressor valve, piston and heads if allowed to return in the suction line.

A vapor is said to be superheated when its temperature is higher than the saturation temperature corresponding to its pressure. The amount of the superheat is, of course, the temperature increase above the saturation temperature at the existing pressure.



## Section 22: HEATING AND AIR CONDITIONING

As the refrigerant moves along in the evaporator, the liquid boils off into a vapor and the amount of liquid decreases until all the liquid has evaporated due to the absorption of a quantity of heat from the surrounding atmosphere equal to the latent heat of vaporization of the refrigerant. The gas continues along in the evaporator and remains at the same pressure. However, its temperature increases due to the continued absorption of heat from the surrounding atmosphere. The degree to which the gas refrigerant is superheated is related to the amount of refrigerant being fed to the evaporator and the load to which the evaporator is exposed.

### Superheat Adjustment

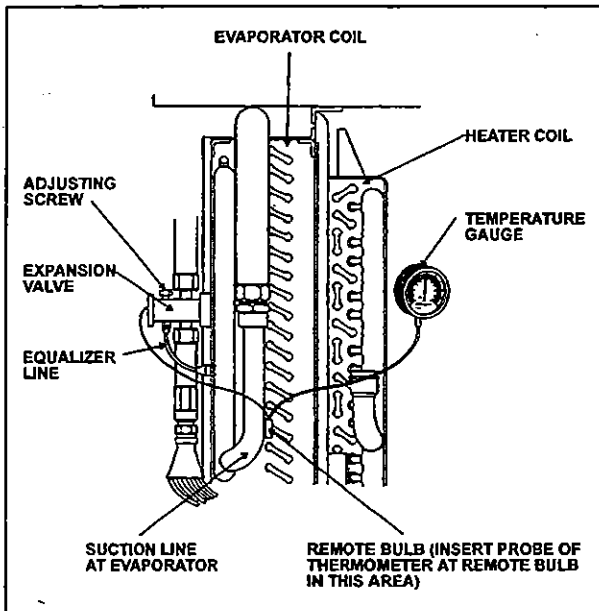

Figure 27: Superheat Adjustment Installation 22046

The easiest method of adjusting the superheat is to backseat the main evaporator expansion valve adjusting screw, and screw in 5-1/2 turns clockwise (refer to Fig. 27). If this method does not provide an accurate superheat, the following procedure should be followed:

1. Operate coach for at least one-half hour at fast idle with temperature control set at 82°F (27,7°C).
2. Install pressure gauge at the evaporator suction header.

3. Install a remote reading thermometer to the evaporator outlet line near the existing remote bulb (refer to Fig. 27).
4. Apply thermostatic tape around the bulb and evaporator outlet line to get a true reading of the line temperature.
5. Check approximately 5 readings of pressure at 2-minute intervals and convert to temperature using the temperature pressure (page 43). Likewise check the temperature reading at the remote bulb at the same 2-minute intervals and record the low and high swing readings of the needle (refer to Fig. 28).

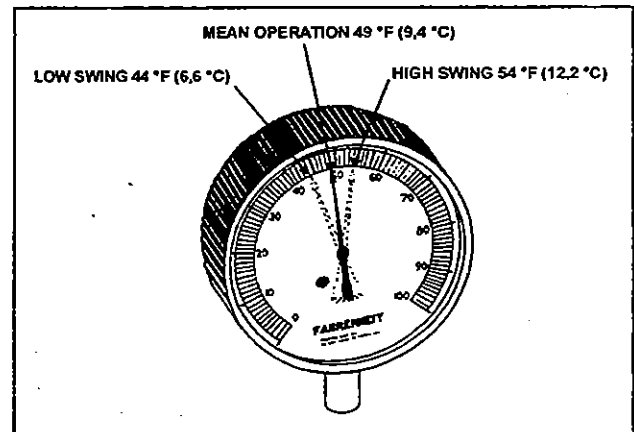

Figure 28: High & Low Swing Temperature at Remote bulb 22047

### EXAMPLE OF READINGS TAKEN (Fig. 28):

A/C pressure gauge converted to temperature at expansion valve fitting	Temperature on remote bulb	
40°F(4,4°C)	Low swing	High swing
	44°F (6,6°C)	54°F (12,2°C)
Formula for superheat 49°F-40°F=9°F (9,4°C-4,4°C=5°C)	Average of low and high swing is 49°F (9,4°C)	

## Section 22: HEATING AND AIR CONDITIONING

**Note:** The low swing of the superheat should be a minimum of 4°F (2,2°C) higher at the remote bulb and have an average of 8 to 12°F (4 to 6°C) higher range at the bulb than the fitting at the expansion valve.

**Note:** To lower evaporator temperature or reduce the superheat, flow of refrigerant is increased by turning adjusting screw of expansion valve counterclockwise. To increase temperature or increase superheat, flow of refrigerant is reduced by turning adjustment screw of expansion valve clockwise.

6. Regulate suction pressure to temperature reading according to temperature chart or to the 134a temperature scale on the pressure gauge.

Example: Suction pressure 30 psi (207 kPa) converted to 32°F (0°C) on chart. If temperature reading is 40°F (4,4°C), subtract 32°F (0°C) and the result will be 8°F (4,4°C) of superheat.

**Caution:** Before proceeding to the expansion valve adjustment, check for restriction on suction side for plugged filter dryer and partially open valves. These conditions will give a high superheat.

### Maintenance

1. Pump down the system as previously indicated in this section.
2. Disconnect the external equalizer line from the under side of the power head, and unclamp the remote control bulb from the evaporator coil outlet line.
3. Remove the two cap screws holding the power assembly to the valve body flange. Lift off the power assembly and remove the cage assembly.

4. When reassembling, replace with the new gaskets in proper location. Make sure the two lugs on the cage assembly fit into grooves provided in the power assembly. Do not force the valves together. The cage must fit properly before tightening the body flange. Tighten bolts evenly.
5. Check for leaks.

### Safety Instructions

1. Make sure the valve is installed with the flow arrow on the valve body corresponding to the flow direction through the piping system.
2. Before opening any system, make sure the pressure in the system is brought to and remains at the atmospheric pressure. Failure to comply may result in system damage and/or personal injury.

### 10.8.2 Driver's System

The function and operation of the expansion valve for the driver's system are similar to the main system, but no superheat adjustment is required (see fig. 17).

### 10.9 Torch Brazing

Use an electrode with 35% silver.

**Caution:** When using heat near a valve, wrap with a water saturated rag to prevent overheating of vital parts.

**Warning:** Before welding any part of refrigeration system, make sure the area is well ventilated.

## 10.10 Troubleshooting

### 10.10.1 Expansion Valve

PROBABLE CAUSE	PROBABLE REMEDY
<b>LOW SUCTION PRESSURE-HIGH SUPERHEAT</b>	
Expansion Valve Limiting Flow.	
Gas in liquid line due to pressure drop in the line or insufficient refrigerant charge.	Locate cause of line flash and correct by use of any of the following methods. Add R-134a. Replace or clean filter dryer.
Inlet pressure too low from excessive vertical lift, undersize liquid line or excessive low condensing temperature. Resulting pressure difference across valve too small.	Increase head pressure. If liquid line is too small, replace with proper size.
Gas in liquid line due to pressure drop in line or insufficient refrigerant charge.	Locate cause of liquid line flash and correct by use of any of the following methods. Add R-134a. Replace or clean filter dryer. Check for proper line size.
Superheat adjustment too high.	Adjust superheat as outlined under "Superheat Adjustment".
Power assembly failure or partial loss of charge.	Replace power assembly or replace valve.
Air filter screen clogged.	Clean or replace air filter screen.
Plugged lines.	Clean, repair or replace lines.
Liquid line too small.	Install proper size liquid line.
Suction line too small.	Install proper size suction line.
<b>LOW SUCTION PRESSURE-LOW SUPERHEAT</b>	
Uneven or inadequate evaporator loading due to poor air distribution or liquid flow.	Balance evaporator load distribution by providing correct air or liquid distribution.
<b>HIGH SUCTION PRESSURE-HIGH SUPERHEAT</b>	
Compressor discharge valve leaking.	Replace or repair valve.
<b>HIGH SUCTION PRESSURE-LOW SUPERHEAT (DEFECTIVE UNLOADER)</b>	
Valve superheat setting too low.	Adjust superheat as outlined under "Superheat Adjustment".
Compressor discharge valves leaking.	Replace or repair discharge valve.
Incorrect superheat adjustment.	Superheat adjustment 8 to 12°F (4 to 6°C).

**Section 22: HEATING AND AIR CONDITIONING**

PROBABLE CAUSE	PROBABLE REMEDY
<b>FLUCTUATING DISCHARGE PRESSURE</b>	
Insufficient charge.	Add R-134a to system.
<b>HIGH DISCHARGE PRESSURE</b>	
Air or non-condensable gases in condenser.	Purge and recharge system.
Overcharge or refrigerant.	Bleed to proper charge.
Condenser dirty.	Clean condenser.
Insufficient cooling air distribution over air cooled condenser.	Properly locate condenser to freely dispel hot discharge air.

**10.10.2 A/C**

TROUBLE	CAUSE
Low suction pressure and frosting at dryer outlet.	Clogged filter.
Low Oil Level.	Check for oil leaks and for leaking oil seal. Do not attempt to check oil level unless system has been stabilized at least 20 minutes.
Excessively cold suction line.	Loss of contact between the expansion valve bulb and the suction line or sticking of the expansion valve.  Check for foreign matter and clean, repair or replace the valve.
Excessively cold suction line and noisy compressor.	Check superheat adjustment. Check remote bulb contact. Check expansion valve for sticking.
compressor squeaks or squeals when running.	Check oil level. Replace oil seal.
Noisy or knocking compressor.	Check for broken internal parts. Overhaul if required.
Compressor vibrates.	Check and tighten compressor mounting bolts.
Low refrigerant level	Check for refrigerant leaks and add refrigerant if required.
Suction pressure rises faster than 5 pounds per minute after shutdown.	Check compressor valve for breakage or damage.
Insufficient cooling.	Check for refrigerant leaks. Check condition of filter screens and motors.
Insufficient air flow.	Dirty or iced evaporator. Dirty air filter. Blowers inactive. Clogged ducts.
No flow of refrigerant through expansion valve.	Filter dryer is clogged. Remote bulb has lost charge or expansion valve is defective.
Expansion valve hisses. Bubbles in moisture and liquid indicator.	Gas in liquid line. Add refrigerant.
Loss of capacity	Clogged filter. Obstructed or defective expansion valve.

**Section 22: HEATING AND AIR CONDITIONING**

TROUBLE	CAUSE
Superheat too high.	Reset superheat adjustment. Check for clogged external equalizer line, or filter dryer.
Reduced air flow: a. Dirty or clogged air filter; b. Evaporator motor inoperative; or c. Plugged return air ducts.	Dirty or iced evaporator coil. Clean air filter screen. Check return ducts for obstructions. Check blower motor.
Frequent startings and stoppings on low pressure control switch.	Lack of refrigerant. Check for leaks. Recharge.
Compressor intermittently starts and stops.	Intermittent contact in electrical control circuit. Compressor valves not in operating position.
<p>The most common problem of air cooled condenser is high head pressure. Most frequent causes are:</p> <p>1. Reduced air quantity. This may be due to:</p> <ul style="list-style-type: none"> <li>• Dirt on the coil;</li> <li>• Restricted air inlet or outlet;</li> <li>• Dirty fan blades;</li> <li>• Incorrect rotation of fan;</li> <li>• Fan speed too low;</li> <li>• Fan motor going out on overload; or</li> <li>• Prevailing winds.</li> </ul> <p>2. Non-condensable in the refrigeration system. This may be due to: Leak on low side system, system in vacuum.</p> <p>Specific symptom, pressure in system will not correspond to ambient temperature on shutdown. Only non-condensable will cause this.</p> <p>(Example: Pressure of idle R-134a system in 80°F (26,6°C) room should be 86.4 psi (595.7 kPa). See temperature chart in this section.)</p> <p>An evaporator just does a proper cooling job without sufficient air. Shortage of air can be caused by the following:</p> <ul style="list-style-type: none"> <li>• Dirty filters; or</li> <li>• Dirty coils.</li> </ul>	

### 10.11 Temperatures & Pressures

VAPOR-PRESSURE			
TEMPERATURE		PRESSURE	
°F	°C	psi	kPa
-100	-73.3	27.8	191.7
-90	-67.8	26.9	185.5
-80	-62.2	25.6	176.5

**Section 22: HEATING AND AIR CONDITIONING**

<b>VAPOR-PRESSURE</b>			
<b>TEMPERATURE</b>		<b>PRESSURE</b>	
<b>°F</b>	<b>°C</b>	<b>psi</b>	<b>kPa</b>
-70	-56.7	23.8	164.1
-60	-51.1	21.5	148.2
-50	-45.6	18.5	127.6
-40	-40.0	14.7	101.4
-30	-34.4	9.8	67.6
-20	-29	3.8	26.2
-10	-23	1.8	12.4
0	-18	6.3	43.4
10	-12	11.6	80
20	-7	18.0	124.1
30	-1	25.6	176.5
40	4	34.5	237.9
50	10	44.9	309.6
60	16	56.9	392.3
70	21.1	70.7	487.5
80	27	86.4	595.7
90	32.2	104.2	718.5
100	38	124.3	857.0
110	43.3	146.8	1012.2
120	49	171.9	1185.3
130	54.4	199.8	1377.6
140	60	230.5	1589.3
150	65.6	264.4	1823.0
160	71	301.5	2078.8
170	76.7	342.0	2358.1
180	82.2	385.9	2660.8
190	87.8	433.6	2989.7
200	93.3	485.0	3344.1
210	98.9	540.3	3725.4

## 10.12 Leak Testing

Some methods such as nitrogen pressure and soap, and electronic sniffer can be used for leak testing. However, the most common method used is a Halid torch consisting of an acetylene tank, a burner and a suction test hose. Proceed as follows:

**Warning:** *Do not inhale fumes from leak detector.*

The flow of acetylene to the burner causes a suction in the test line. Any gas refrigerant present will be drawn through the hose and into the burner where it decomposes into free acids.

These acids come in contact with the hot copper reaction plate in the burner, causing color reaction in the flame. A small concentration is indicated by a green tint and a large concentration by an intense blue. Do not confuse this change in color with the change caused by shutting off the air supply through the hose by holding the end too close to an object.

The procedure for testing is:

1. Adjust flame so that the top of the cone is approximately level or within one-half inch above the plate.
2. Probe end of suction test tube around all joints, valves, etc. When a leak has been found at a soldered joint, that section of the system must be pumped down. Do not solder as pressure will force hot solder out. If the system is empty, it is more economical to put in just enough R-134a to produce about 15 psi (103 kPa). The pressure can be raised to about 150 psi (1034 kPa) with dry nitrogen.

**NOTE:** *This gas is put into the suction and discharge shutoff valves at the compressor. The receiver valves must be opened. If no leaks are found, dump this mixture, evacuate the system and fill with refrigerant.*

## 11. HEATING SYSTEM

### 11.1 Description

The schematic of Figure 29 shows the heating system and its components.

In addition to the normal heating provided by the engine, an optional preheating system (40,000 Btu/hr or 80,000 Btu/hr) may have been installed in the rear electric compartment.

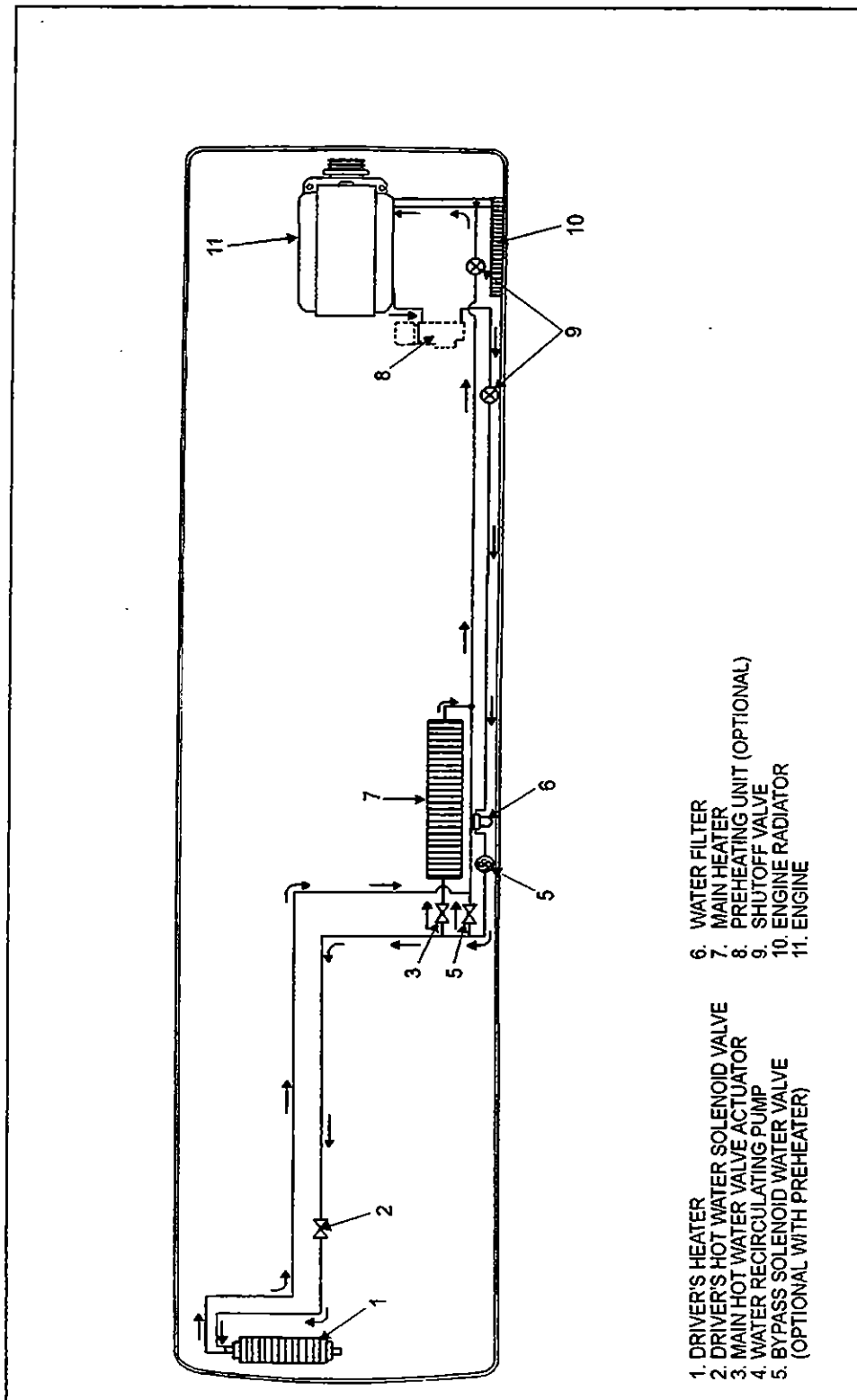

- 1. DRIVER'S HEATER
- 2. DRIVER'S HOT WATER SOLENOID VALVE
- 3. MAIN HOT WATER VALVE ACTUATOR
- 4. WATER RECIRCULATING PUMP
- 5. BYPASS SOLENOID WATER VALVE (OPTIONAL WITH PREHEATER)
- 6. WATER FILTER
- 7. MAIN HEATER
- 8. PREHEATING UNIT (OPTIONAL)
- 9. SHUTOFF VALVE
- 10. ENGINE RADIATOR
- 11. ENGINE

Figure 29: Heating System Components

22048



## 11.2 Draining Heating System

To drain the entire system, refer to Section 05, "Cooling". If only the driver's or main heater core must be drained, refer to the following instructions.

### 11.2.1 Driver's Heater Core

1. Stop engine and allow engine coolant to cool.
2. Locate the normally open water solenoid valve on the ceiling of the spare wheel compartment (Fig. 30), disconnect its wiring connector, then connect a 24-volt external power source, using jumper cables, to close valve.

**Warning:** Before proceeding with the following steps, check that coolant has cooled down.

3. Loosen hose clamp, install an appropriate container to recover coolant, and disconnect silicone hose from water solenoid valve.
4. From inside of vehicle, open the manual vent on the coolant inlet line near the driver's unit (Fig. 31) to ensure an efficient draining.

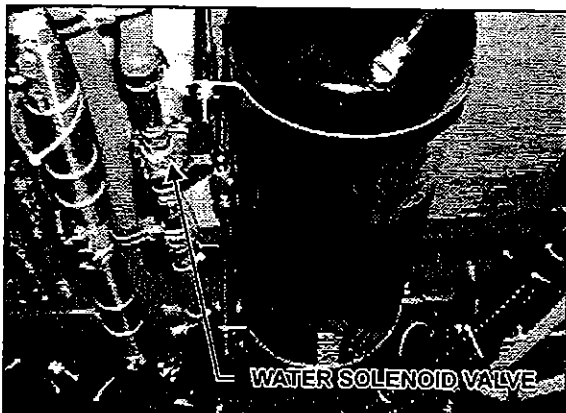

Figure 30

22049

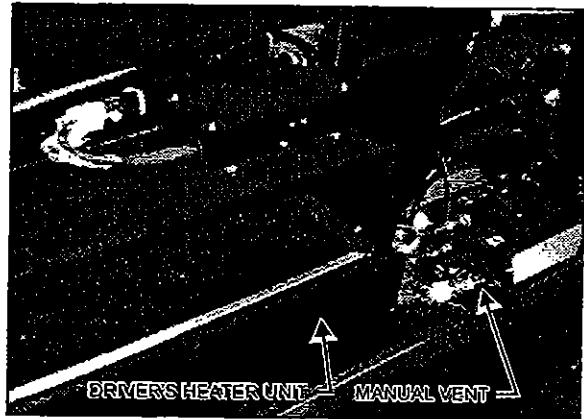

Figure 31: Driver's HVAC Unit

22050

### 11.2.2 Main Heater Core

1. Stop engine and allow engine coolant to cool.
2. Close both heater line shutoff valves. One is located in the engine compartment under the radiator fan gearbox, while the other one is located in the L.H. rear electric compartment near the pre-heater. Refer to 12.6 Preheater System of this section to gain access to the heater line shutoff valve.
3. Open the last L.H. side baggage compartment door, then pull the black release button located on the L.H. side in order to unlock and open the HVAC compartment door.

**Warning:** Before proceeding with the following step, check that coolant has cooled down.

4. Open drain cock in bottom of heater core, then open manual vent located on top of heater core (Fig. 32) in order to allow air to enter while draining.

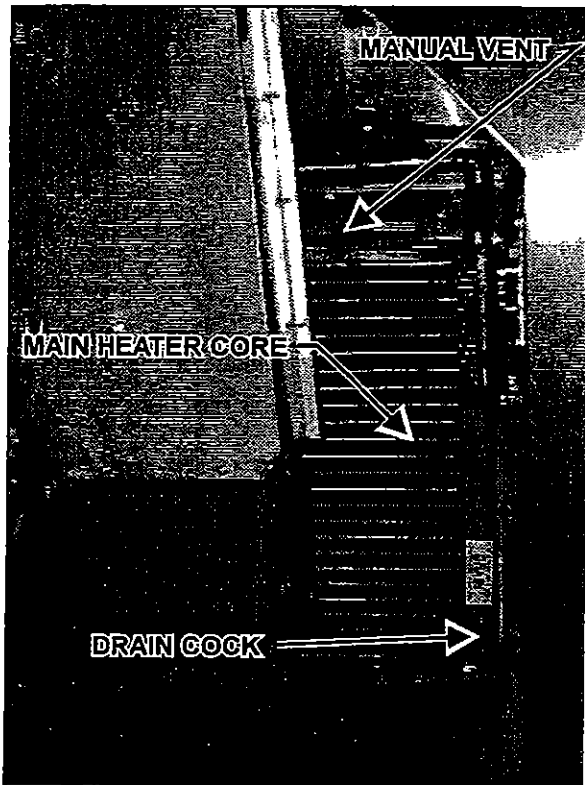

Figure 32: HVAC Compartment

22051

### 11.3 Filling Heating System

1. Ensure that the drain hose is reconnected and the manual vents and drain cock are closed.
2. Open the surge tank filler cap and slowly fill the system to level of filler neck.
3. After initial filling, the water valves should be open and the water recirculating pump should be energized to assist in circulating coolant through the heating system. To perform this operation, start the engine, switch on the "Main A/C-Heating" switch, and turn the "Main and Driver's A/C-Heating Temperature" controls clockwise to their maximum positions in order to request the heating mode in each of these sections.

4. When coolant level drops below the surge tank filler neck, slowly fill the system to level of filler neck.
5. Once the level has been stabilized, replace surge tank filler cap.

### 11.4 Bleeding Heating System

Whenever the heating system has been drained and refilled, or the system has run low on coolant and coolant has been added, it is necessary to bleed air from heating system. Locate the manual vents illustrated in Figures 31 and 32, and open them momentarily until no air escapes from the lines.

### 11.5 Soldering

Before soldering any part of the system, make sure the area is well ventilated. Use (stay clean) flux sparingly and apply solder (95-5 round wire 1/8 inch [3,1 mm]). After completing repairs, test for leaks.

When using heat at or near a valve, wrap with a water saturated rag to prevent overheating of vital parts.

## 12. HEATING SYSTEM COMPONENTS

### 12.1 Driver's Water Solenoid valve

#### 12.1.1 Description

A two-way normally open, internal pilot-operated solenoid valve designed for smooth closing is used to control the coolant flow through the driver's heating unit. It is mounted on the coolant inlet line of the driver's heating unit, and is accessible through the spare wheel compartment (see fig. 29). The valve cannot be manually bypassed.

### 12.1.2 Improper Operation

1. Faulty control circuit: Check the electric system by energizing the solenoid. A metallic clicking noise indicates that the solenoid is operating. Absence of clicking indicates a loss of power or a defective solenoid. Check for open breaker, open-circuited or grounded coil, broken lead wires.
2. Burned-out coil: Check for open-circuited coil. Replace coil if necessary.
3. Low voltage: Check voltage across the coil leads. Voltage must be at least 85% of nameplate rating.
4. Excessive leakage: Disassemble valve and clean all parts. Replace worn or damaged parts with a complete spare part kit for best results.

### 12.1.3 Coil Replacement

Turn off electrical power supply and disconnect lead wires. Proceed in the following manner:

1. Remove retaining cap or clip, spacer, name plate and housing.
2. Slip spring washer, insulating washer, coil and insulating washer off the solenoid base sub-assembly. Insulating washers are omitted when a molded coil is used.
3. Coil is now accessible for replacement. Reassemble by reversing sequence of disassembly. Refer to exploded view (Fig. 33) for identification and location of parts.

**Note:** Solenoid must be completely reassembled, as the housing and internal parts complete the magnetic circuit.

**Caution:** When metal retaining clip disengages, it will spring upwards.

### 12.1.4 Valve Disassembly

1. Drain driver's heating unit as previously explained in this section under paragraph "Draining Heating System".
2. Disconnect connector from coil connector.
3. Disassemble valve in an orderly fashion paying careful attention to exploded view (Fig. 33) provided for identification of parts.
4. Remove retaining cap and slip the entire solenoid enclosure off the solenoid base subassembly.

**Caution:** When metal retaining clip disengages, it will spring upwards.

5. Unscrew solenoid base sub-assembly and remove core, plugnut gasket, plugnut assembly and solenoid base gasket.
6. Remove the four bonnet screws and valve bonnet, disc holder subassembly, disc holder spring, diaphragm/spring subassembly and body gasket.
7. All parts are now accessible for cleaning or replacement. Replace worn or damaged parts with a complete spare part kit for best results.

**Caution:** Do not damage valve seat in any manner, as its sealing feature will be affected, thus resulting in continuous leakage.

Section 22: HEATING AND AIR CONDITIONING

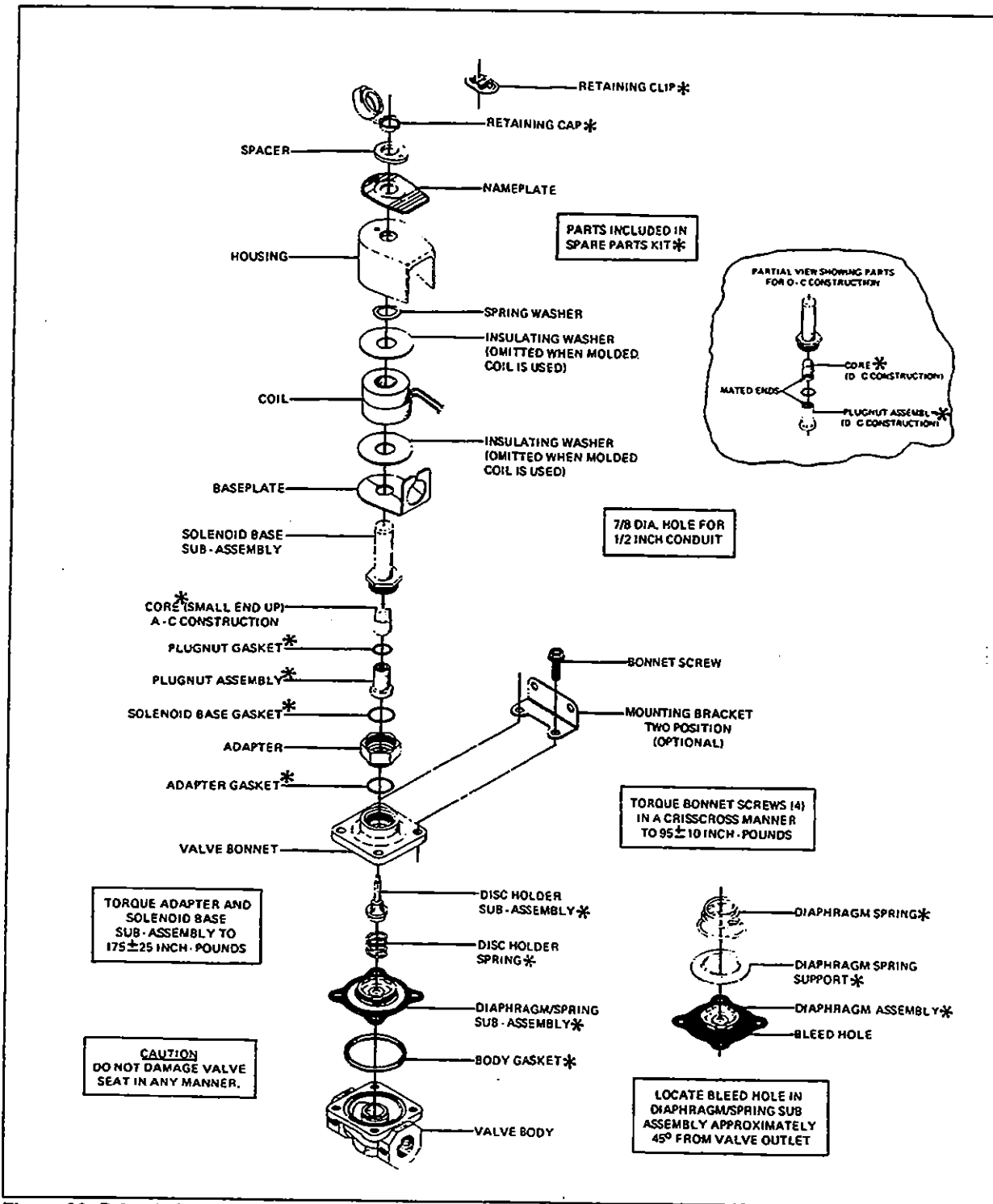

Figure 33: Driver's Water Solenoid Valve

22052

### 12.1.5 Valve Reassembly

1. Reassemble in reverse order of disassembly paying careful attention to exploded view provided for identification and placement of parts (Fig. 33).
2. Replace body gasket and diaphragm/spring subassembly. Locate bleed hole in diaphragm/spring subassembly approximately 45° from valve outlet.
3. Replace disc holder spring and holder subassembly.
4. Replace valve bonnet screws. Torque bonnet screws in a criss-cross manner to  $95 \pm 10$  inch-pounds.
5. Install solenoid base gasket, plugnut assembly and plugnut gasket. Position core (small end up for A-C construction) on plugnut assembly. For D-C construction, be sure plugnut assembly and core are installed with mated ends together.
6. Replace solenoid base subassembly and torque to  $175 \pm 25$  inch-pounds.
7. Replace solenoid enclosure and retaining cap or clip. Reconnect the coil connector.
8. Refill heating system as previously stated under paragraph "Filling Heating System", then bleed air from the driver's heating unit as stated previously under paragraph "Bleeding heating system".
9. After maintenance, operate the valve a few times to be sure of proper opening and closing.

**Note:** Should diaphragm/spring subassembly become disassembled, be sure to replace the diaphragm/spring support with lip facing upward towards the valve bonnet.

## 12.2 Main Hot Water Solenoid Valve Actuator

### 12.2.1 Description

The flow of hot water to the vehicle main heater core is controlled by an electric water valve. The valve is located in the HVAC compartment (Fig. 29 and 34). This valve is self-adjusting and linear motorized.

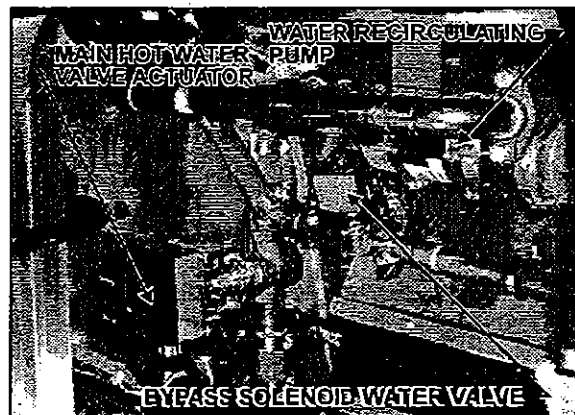

Figure 34: HVAC Compartment

22053

If leakage occurs after several years of operation, check stem and seat for wear. If either is worn, completely rebuild the valve, replacing all parts subject to wear. This normally includes replacing packing, stem, disc, internal springs, seats or seat rings, O-rings, and gaskets as applicable to the valve being rebuilt.

Any valve with a stem in good condition may be repacked without further repair. It is not necessary to remove the bonnet to repack the valve. Great care should be taken not to damage the valve stem or cause leakage after the packing is installed.

After repairing, use pipe sealing compound or tape on bonnet threads and threaded piping connections. Restore hot water pressure to test for leaks before reinstalling actuator. Remember that pressure forces the valve open during testing when actuator is off. Reinstall the actuator and check operation to be certain valve closes completely against normal operating pressures.

## Section 22: HEATING AND AIR CONDITIONING

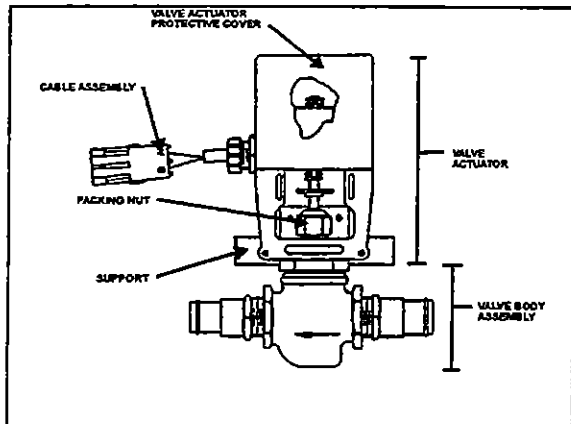

Figure 35: Main Hot Water Solenoid Valve 22054

### 12.2.2 Valve Actuator Removal (Figure 35)

1. Stop engine and allow coolant to cool.
2. Close shutoff valve on the line located in the rear electric compartment to relieve water pressure from system. Refer to 12.6 Pre-heater System of this section to gain access to the heater line shutoff valve.
3. Disconnect cables and the fresh air sensor. Remove the main hot water solenoid valve actuator from the line by removing connectors at pipe outlets and removing screws on the support.
4. Remove the two screws retaining the valve actuator protective cover.
5. Remove the four screws retaining the collar.
6. Remove the stem button.
7. Remove the actuator valve.

### 12.2.3 Valve Repacking

1. Hold stem by inserting a 1/16 inch diameter rod or nail in hole near the top of the stem. Unscrew the stem button. Do not tamper with the top locking set screw in stem button.
2. Remove packing nut, old packing, packing follower, and spring. Install new spring and packing follower. Use a small amount of lu-

bricant Amoco H-100 and thread new packing very carefully over the stem with concave side down for 250 psi (1724 kPa) rubber packing.

3. Reinstall packing nut by pushing down to compressed spring until threads engage, and tighten until snug. Be certain the valve stem moves up and down. Reinstall stem button, stem extension (if applicable), and actuator.

### 12.2.4 Valve Rebuilding

Follow disassembly procedures as applicable. Replace all parts subject to wear and damage. Reassemble in reverse order using new parts.

**Note:** Run down all bonnet cap screws until fingertight, and proceed to torque down evenly using a reduced torque. Space successive tightening at 180 degrees, etc, until the bonnet raised face contacts the body on all sides. Then apply torque as specified.

### 12.2.5 Disassembly Procedures

1. Relieve water pressure from system and remove actuator.
2. Hold stem by inserting a 1/16 inch diameter rod or nail in the hole near the top. Partially unscrew set screw inside the motor actuator. Do not tamper with locking set screw in the top of the stem button. Unscrew motor.
3. Remove packing nut and all parts down to the bonnet.
4. Remove stem and plug. Direct acting threaded body valves (Fig. 36). Unscrew the bonnet. Lift out the stem and disc holder assembly and the plug.
5. Disassemble stem and plug. Threaded body valves. Unscrew plug (Fig. 36) from stem to remove disc and spring. The disc may have to be pried from the disc holder with a screwdriver. The valves have a staked stem and disc holder assembly (Fig. 36). The stem and plug cannot be disassembled on some valves with metal-to-metal seats.

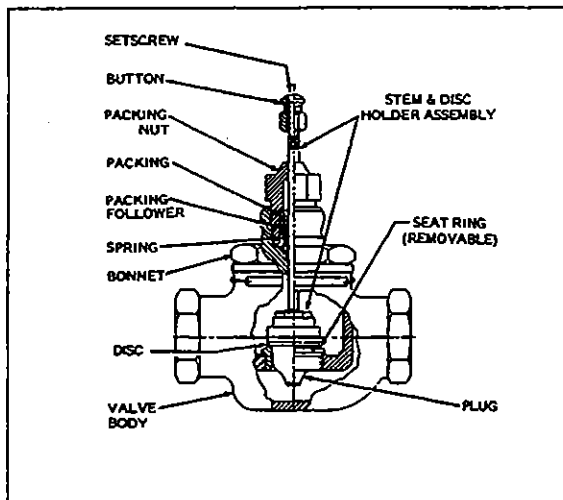

Figure 36: Valve Body Assembly

22055

## 12.2.6 Maintenance

Using solvent, remove all dirt and grease accumulation around the packing nut and stem.

**Warning:** *Permanent damage to respiratory system or skin tissue can result from careless handling of solvents. Special care should be exercised to avoid prolonged inhalation and/or contact with the skin.*

## 12.3 Water Recirculating Pump

### 12.3.1 Description

This vehicle is provided with a water recirculating pump which is located in the HVAC compartment. The water recirculating pump consists in a centrifugal pump and an electric motor which are mounted on a common shaft in a compact assembly.

The motor is equipped with prelubricated sealed ball bearings which require no maintenance. A self-adjusting mechanical shaft seal is incorporated in this assembly to prevent coolant leakage between the pump cavity and armature shaft. This seal derives its lubrication from the liquid pumped, and it will be destroyed if permitted to operate dry.

This pump requires no periodic maintenance other than replacement of motor brushes. Replacement of motor brushes can be performed without removing the pump assembly. Visual inspection of the pump should be made while the pump is in operation to determine if the shaft seal is intact. If there is evidence of coolant leakage, the unit must be disassembled for corrective measures. Disassembly of the pump will be necessary only in the case of a seal leak, bearing failure, or motor failure.

### 12.3.2 Removal

1. Stop engine and allow engine coolant to cool.
2. Close shutoff valve on the line located in the rear electric compartment. Refer to 12.6 Preheater System of this section to gain access to the heater line shutoff valve.
3. Disconnect the electrical wiring from the motor.

**Warning:** *Before proceeding with the following steps, check that coolant has cooled down.*

4. Remove the drain plug at the bottom of the pump and place a container to recover the residual coolant in the line.
5. Disconnect water lines from the pump at the flange connections.
6. Remove the two clamps holding the pump motor to its mounting bracket. Remove the pump with the motor as an assembly.

### 12.3.3 Disassembly (Refer to Fig. 37, Water Recirculating Pump and Motor)

1. Remove two brush caps (16, Fig. 37) and two brush assemblies (15, Fig. 37). When removing brushes, note the position of the brush in the tube. Brush life is significantly decreased if brushes are not replaced properly.

## Section 22: HEATING AND AIR CONDITIONING

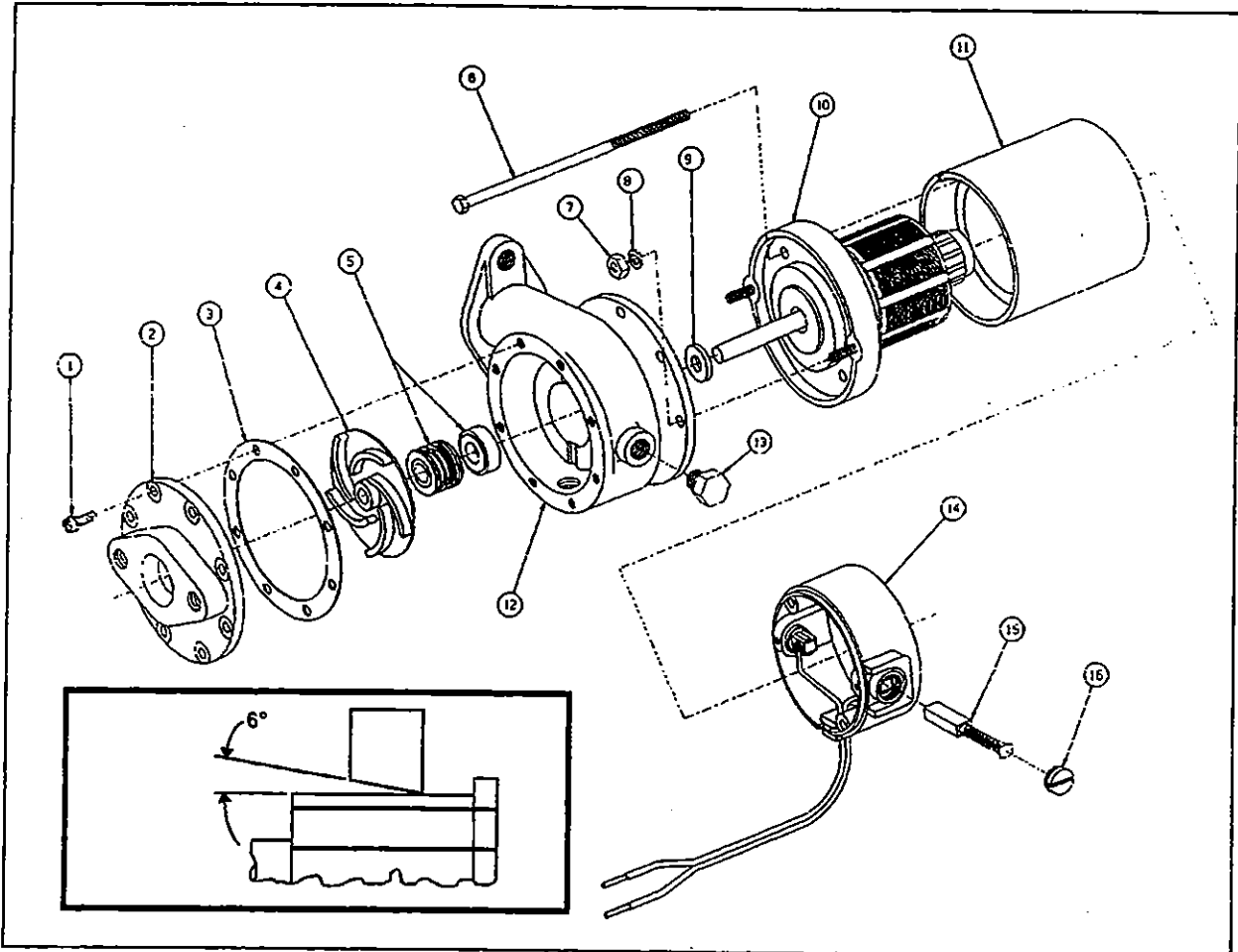

Figure 37: Water Recirculating Pump

22056

2. Remove the pump cover (2, Fig. 37) by removing eight head screws. Remove cover carefully to prevent damage to gasket (3, Fig. 37).
3. Remove gasket (3, Fig. 37).
4. Remove two hex nuts and lock washers which hold pump assembly to the motor.
5. Remove the pump from the motor as follows:
  - a. Install puller tool assembly (MP Co. Part No. 24702 or equivalent) to pump body (12) using four screws removed from the pump cover (2).
    - b. Tighten the puller screw to press the motor shaft out of the impeller hub. The pump is now free from the motor.
  6. Remove the puller tool.
  7. Remove impeller (4) and components of the pump seal assembly (5).

**Caution:** Do not scratch or mar the sealing surface of this seat, as its sealing feature will be affected, thus resulting in continuous leakage.

### Inspection

Components removed from the recirculating pump and motor assembly should be compared with new parts to determine the degree of wear.



### 12.3.4 Brushes

1. When removing brushes, note the position of the brush in the tube. Brush life is shortened if the brushes are not replaced properly.

2. Examine brushes for the following:

a. Wear

Replace the brushes if less than 25% of the usable brush is left (less than 0.300 inch [8 mm]).

b. Chipped edges

Chips can be caused by improper handling or installation. Badly chipped brushes should be replaced regardless of their length.

c. Annealed brush spring

This can be detected by noting the resiliency of the spring. Annealing is caused by failing to tighten the brush caps properly, thus not providing a good low resistance contact between the terminal and the brush tube. Replace brushes showing evidence of annealed springs.

d. Frayed or broken pigtail

An improperly installed brush may have the pigtail (shunt) pinched under the terminal or between the coils of the spring. If the pigtail is badly frayed or broken, replace the brush.

3. Observe the following factors when replacing brushes:

- a. The face of a new brush is carefully cut to cause proper seating during the "wear-in" period.
- b. Improper installation can harm both the brush and the commutator.

- c. Replacement brushes should be of the proper grade.

- d. Brush performance will be affected if the spring and terminal are not properly placed in the brush tube. The spring should be free over its entire length and the terminal should make good contact with the metal brush tube insert.

### 12.3.5 Bearings (Fig. 37)

1. Rotate the motor shaft. If the ball bearings show evidence of wear, they should be replaced.
2. The use of a bearing puller is recommended when removing the bearings to help prevent damaging the armature winding or the commutator.
3. Replacement bearings should be pressed into the same exact location as the original bearings.
4. It is recommended that a suitable sealant (such as Loctite or equivalent) be used between the shaft and the bearing, if the fit is not tight enough to prevent the shaft from spinning inside the inner race.
6. After replacing the bearings, check the position of the commutator in the motor by looking down into the brush tube. Neither the riser nor the edge of the commutator should be visible.

### 12.3.6 Commutator

1. The commutator is a precise assembly. Although it is solidly built and made of a fairly tough material, it can be easily ruined by careless handling.
2. The commutator should be refinished only on equipment which provides good concentricity and the proper finish.

## Section 22: HEATING AND AIR CONDITIONING

3. The commutator should be refinished if a micrometer reading shows a difference between "in track" and "off track" diameter of 0.187 inch (4,7 mm) or more.
4. The commutator should be carefully undercut with a 0.025 inch (0,6 mm) or less slot width.
5. A 25 to 50 micromesh finish is desirable on a new or refinished commutator.
6. The commutator should not be touched with the fingers since sweat and body oils will rapidly discolor and oxidize its surface.
- b. Invert the motor and pump body assembly, then pilot the pump shaft into the impeller bore. **DO NOT HAMMER** on the motor shaft extension at rear of motor.
- c. Press on motor and pump body until the machined face of the pump body is flush with the face of the flat surface on which the impeller is resting. The face of the impeller vanes must now be flush with the machined face of the pump body.
5. Install gasket (3). This gasket serves both to seal the cover and to establish the proper clearance between the face of the impeller and the pump cover.

### 12.3.7 Miscellaneous (Fig. 37)

1. Check the shaft slinger (9) to make sure it is tight on the motor shaft. If the slinger slips on the shaft, it should be replaced.
2. Inspect seal assemblies (5) to determine wear. If the seal has leaked, or is badly worn, it is recommended that a complete new seal assembly be installed.
3. The impeller (4) is a press fit on the armature shaft. This press fit must be maintained to prevent the impeller from slipping. Install a new impeller if necessary.

### 12.3.8 Assembly (Fig. 37)

1. Install slinger (9) on the motor shaft.
2. Assemble body (12) to the motor.
3. Install seal assy (5).
4. Install impeller (4) in the following manner:
  - a. Place the impeller on a flat surface with the vanes against the flat surface.

6. Attach cover (2) to the pump body using eight head screws (1).
7. Install motor brushes assembly (15) and brush caps (16).

### 12.3.9 Installation

1. Apply gasket cement to the pump body line adapter and to the line flanges, put the two gaskets in place, and connect water lines from the pump at the flange connections. Position the pump and motor assembly on the mounting bracket. Position the mounting clamps over the motor and secure with mounting bolts.
2. Apply pipe sealant on threads of drain plug, and screw it in place.
3. Connect electrical wiring to the pump motor.
4. Open shutoff valve located in the rear electric compartment (near the preheater). Refer to 12.6 Preheater System of this section to gain access to the heater line shutoff valve.
5. Fill the cooling system as previously instructed in this section under "Filling Heating System", then bleed the system as previously instructed in this section under "Bleeding Heating System".

## 12.4 Water Filter

### 12.4.1 Description

This vehicle is provided with a cleanable water filter, which is located in the HVAC compartment (refer to Fig. 15 and 29(behind the right air duct)).

### 12.4.2 Maintenance

Filter maintenance consists in changing the element at break-in 3000 miles (4 800 km), and subsequently every 50,000 miles (80 000 km) or once a year, whichever comes first.

**Note:** Each time soldering is performed on any water pipe of the heating system, operate heating system a few minutes so that any foreign matter will be routed to the filters. Clean filters.

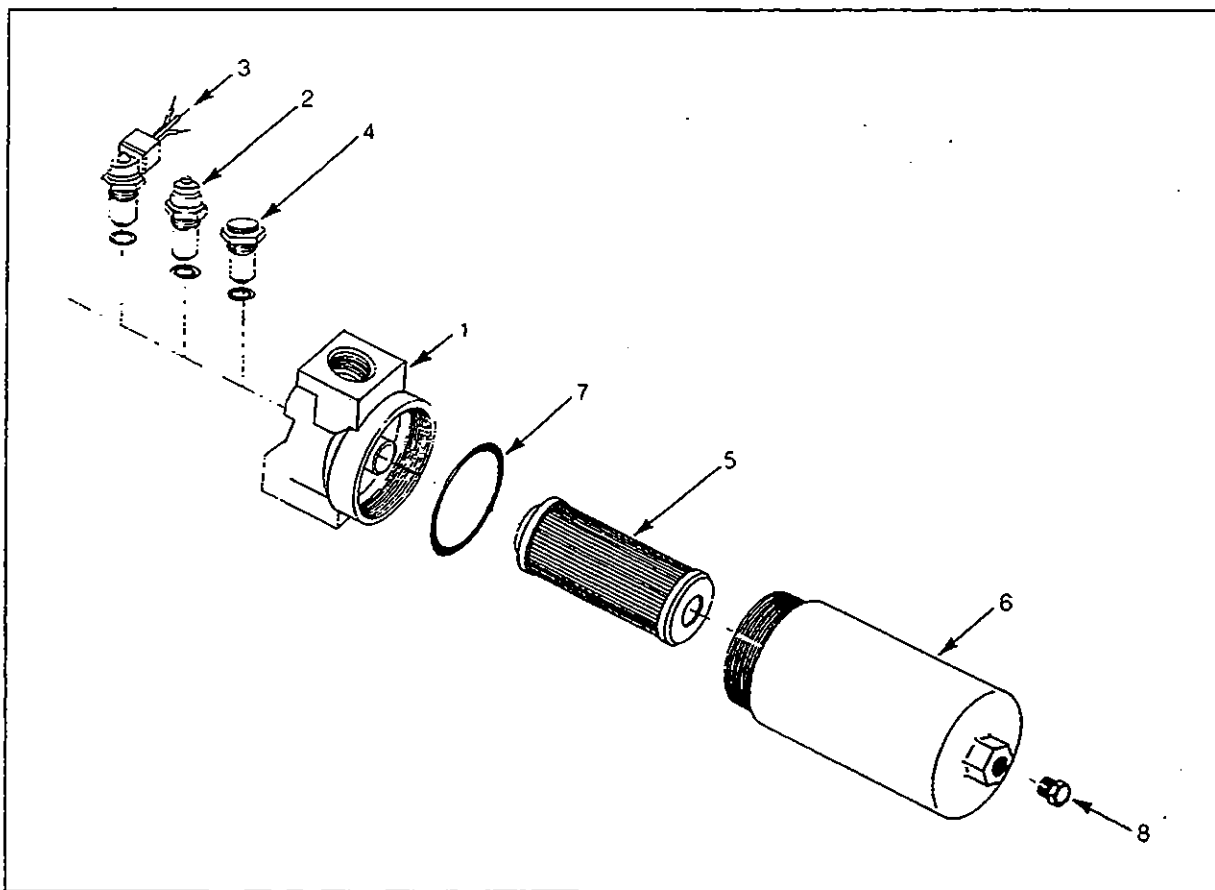

Figure 38: Water Filter

22057

## Section 22: HEATING AND AIR CONDITIONING

### 12.4.3 Filter Servicing (Fig. 38)

1. Stop engine and allow engine coolant to cool.
2. Close shutoff valve on the line located in the rear electric compartment. Refer to 12.6 Preheater System of this section to gain access to the heater line shutoff valve.

**Warning:** Before proceeding with the following steps, check that coolant has cooled down.

3. Rotate bowl (6) counterclockwise and remove.
4. Remove element (5) from housing. Discard all disposable elements. These elements are not cleanable.
5. Place new, clean element in housing, centering it on location in the head.
6. Inspect bowl seal and replace if necessary.
7. Replace bowl. Rotate clockwise and hand tighten.
8. Correct coolant level in surge tank as instructed previously in this section under "Filling Heating System".

### 12.5 Bypass Solenoid Water Valve (Optional)

This valve is optional and is installed on the vehicle equipped with a preheater. The valve is located in the HVAC compartment (Fig. 29). This valve is similar to the driver' liquid solenoid valve. Refer to Fig. 33 for part names.

#### 12.5.1 To Remove or Change the Coil

- Stop engine and allow engine coolant to cool.
- Close shutoff valve on the line located in the rear electric compartment. Refer to 12.6

Preheater System of this section to gain access to the heater line shutoff valve.

#### To remove the solenoid coil:

First take out the retaining screw at the top of the coil housing. The entire coil assembly can be lifted off the enclosing tube.

#### To reassemble:

Make sure that the parts are placed on the enclosing tube in the following order:

1. Be sure to change electrical data plate according to coil specifications change.
2. Place coil and yoke assembly on the enclosing tube. Lay data identification plate in place.
3. Insert the coil retaining screw, rotate housing to proper position and tighten screw securely.

#### 12.5.2 To Take the Valve Apart

##### To disassemble:

This valves may be taken apart by removing the socket head screws which hold the body and bonnet together. After removing the screws, carefully lift off the bonnet assembly (upper part of the valve). Don't drop the plunger. The diaphragm can now be lifted out. Be careful not to damage the machined faces while the valve is apart.

**Note:** The above procedure must be followed before brazing solder type bodies into the line.

##### To reassemble:

Place the diaphragm in the body with the pilot port extension up. Hold the plunger with the synthetic seat against the pilot port. Make sure the bonnet O-rings are in place, the bonnet assembly over the plunger, and that the locating sleeve in the bonnet enters the mating hole in the body. Insert body screws and tighten uniformly.

## 12.6 Preheating System (optional)

The preheater is located in the rear electric compartment. To gain access to the preheater and the heater line shutoff valve. Remove the preheater access panel screws. Remove the panel (Fig. 39).

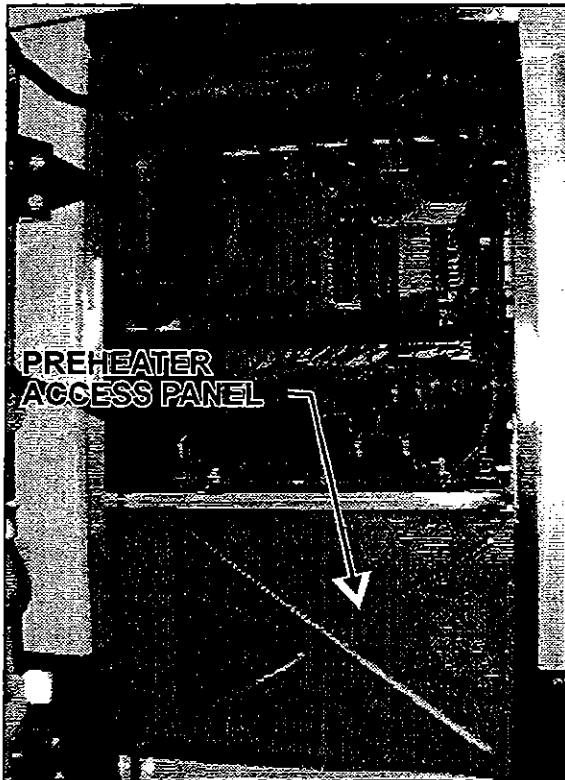

Figure 39: Rear Electric Compartment 22058

### 12.6.1 ESPAR (EBERSPÄCHER)

#### Description of Operations

This Auxiliary Preheating System is used for preheating and retaining the heat of water-cooled engines. It can be used before starting the engine to ease it's starting and to provide immediate inside heat upon operation of the heating system.

It can also be used with engine running to maintain coolant heat and maintain the set temperature inside vehicle.

The heater operates independently from the vehicle engine. It is connected to the cooling and heating circuits, the fuel system and the electrical system of the vehicle.

The pilot lamp turns on when the heater is switched on. Combustion air flows in to flush out the combustion chamber and the water circulation pump is put into operation. The fuel metering pump conveys fuel in precise doses to the combustion chamber where fuel and combustion air form a combustible mixture which is ignited by the glow plug.

Once the flame sensor has signalled to the control unit that combustion has taken place correctly, the glow spark plug and ignition coil are switched off.

The hot combustion gases are diverted at the end of the flame pipe, then pass through the indirect heating surfaces of the heat exchanger and transmit their heat to the water passing through the heat exchanger.

The heat is thermostatically controlled and operates intermittently, i.e. the switched-on times of the burner vary depending on the heat requirement. The water temperature depends on the setting of the built-in water thermostat.

The water circulation pump remains in operation as long as the heater is operating, even in the regulation intervals and during the delayed cutout of the switched-off heater. The pump can also be operated independently from the heater by means of an appropriate circuit. The heater can be switched on at any time, even during the delayed cutout period. Ignition takes place once this delay time is over.

When the heater is switched off, the fuel supply is interrupted. The flame goes out, and at the same time a delayed cutout of some 2.5 minutes begins. The combustion air still flowing flushes the remaining combustion gases out of the chamber and cools off the hot parts on the exhaust side of the heat exchanger, while the water circulation pump, still running, transmits the heat present in the heat exchanger, thus preventing local overheats. Once the delayed cutout time is over, both the combustion air blower and the water circulation pump switch off automatically. A cutout will take place in case of any failure of the preheater.

## Section 22: HEATING AND AIR CONDITIONING

### 12.6.2 WEBASTO

#### Description of Operations

Switch on the heater. The operation indicator lamp comes on and the heater motor and circulating pump begin to run.

After about 10-25 seconds the solenoid valve opens and fuel is sprayed into the combustion chamber. At the same time, the electronic ignition unit produces high voltage (8000 V) and the mixture of fuel and air in the combustion chamber is ignited by the spark on the ignition electrodes.

The flame is indicated by the flame detector, then the electronic ignition unit stops producing high voltage and combustion continues by itself (spark on electrodes is required only to ignite the flame). At this moment, the heater is working and producing heat.

If the heater is switched off by the on/off switch, the solenoid valve interrupts fuel supply, combustion stops and indicator lamp turns off. Combustion air fan still blows air, cleaning the combustion chamber of any fumes and cooling down the combustion chamber. Coolant circulation pumps coolant, making a purge cycle for approximately 2-3 minutes, thus protecting the heater against overheating.

If the heater is not switched off by the on/off switch, the control thermostat will switch off the heater when coolant temperature reaches  $165^{\circ} \pm 6^{\circ}\text{F}$  ( $75^{\circ} \pm 3^{\circ}\text{C}$ ) and turns it on at  $154^{\circ} \pm 9^{\circ}\text{F}$  ( $68^{\circ} \pm 5^{\circ}\text{C}$ ). During this time, the heater (combustion) is off and the indication lamp and coolant pump are on. Combustion air fan blows air for 2-3 minutes and then turns off.

### 12.6.3 PREHEATING SYSTEM TIMERS (AUXILIARY) (Optional)

The timer, located on L.H. lateral is used to program the starting and stopping time of the preheating system. One of two optional Timers may be installed in your vehicle, Espar (40 000 BTU) (Fig. 40) or Webasto (80 000 BTU) (Fig. 41). The system indicator light, located on the dashboard, illuminates when the system is functional. The following offers system descriptions for both timers.

**CAUTION:** The preheating system should not operate for more than one hour before starting engine as this could discharge batteries.

**WARNING:** Preheating system must not operate when vehicle is parked inside or during fuel fill stops.

**NOTE:** Preheating system uses the same fuel as the engine.

In case of failure:

1. Shut off and turn on again.
2. Check main circuit breaker and overheating switch (Espar) or overheat fuse (Webasto).
3. Have system repaired in a specialized shop.

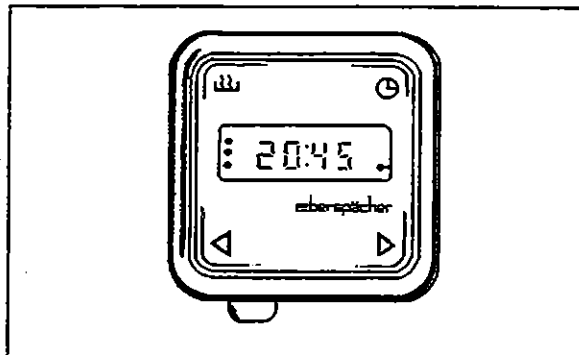

Figure 40: Espar (40 000 BTU)

18045

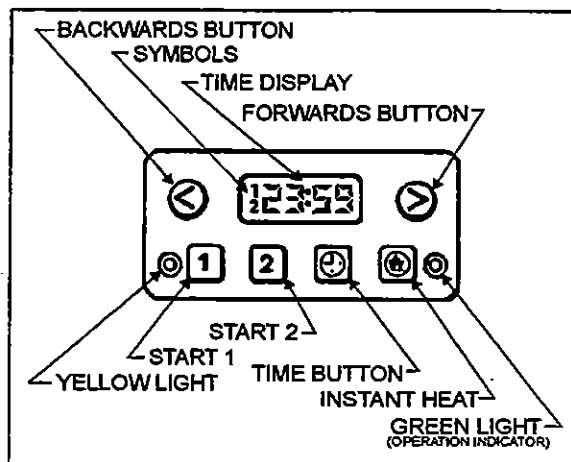

Figure 41: Webasto (80 000 BTU)

18046

### 12.6.4 Troubleshooting and Maintenance

Refer to the Webasto and Espar manuals annexed to the end of this section.

**Note:** Switch on the preheating system briefly about once a month, even during the warm season.

**Caution:** During welding procedure on the vehicle, disconnect the preheater module connector in order to protect this system from voltage surges.

### 13. SPECIFICATIONS

**HVAC Logic panel**

Make ..... Honeywell  
 Model ..... W973B  
 Voltage rating..... 24 volts  
 Switching (on-off stages) ..... Pilot duty spdt relays  
 Input signal (from electronic transmitter) ..... 1 to 16 V DC  
 Supplier number..... W973B1016  
 Prevost number ..... 56-1805

**Electronic transmitter**

Make ..... Honeywell  
 Model ..... T7067B (modified for Prevost)  
 Voltage rating..... 20 volts (from HVAC logic panel)  
 Current draw ..... 20 milliamperes  
 Output signalsTwo 1-16 volt signals ..... (one each for cooling and heating) to HVAC logic panel  
 Output signal rate of change (upon deviation from set point) .....2.5 V DC/1 °F (0,5 °C)  
 Supplier number..... T7067B1006  
 Prevost number ..... 56-1804

**Fresh air inlet sensor**

Make ..... Honeywell  
 Model ..... C7046A  
 Sensing element ..... Carbon type, thermistor-resistor element  
 Nominal resistance .....3000 ohms at 77 °F (25 °C)  
 Nominal sensitivity .....70 ohms/°F (124 ohms/°C) at mid-range  
 Supplier number.....C7046A1004  
 Prevost number ..... 95-0082

**Return air sensor**

Make ..... Prevost  
 Prevost number (air sensor) ..... 06-1961  
 Prevost number (temperature sensor)..... 37-2479

**Discharge air sensor**

Make ..... Honeywell  
 Type .....Non-adjustable thermistor sensor  
 Nominal resistance .....1420 ohms at 75 °F (24 °C)  
 Nominal sensitivity ..... 15 ohms/°F (25 ohms/°C) resistance increases as temperature falls  
 Supplier number..... T7022A1010  
 Prevost number ..... 56-1806

**Section 22: HEATING AND AIR CONDITIONING**

---

**Main evaporator motor**

Make ..... Prevost  
Type ..... T-19  
Voltage ..... 27.5 V DC  
Current draw ..... 69 amps  
Horsepower ..... 2  
Revolution ..... 1750 rpm  
Insulation ..... Class F  
Motor life ..... 20 000 hours  
Brush life ..... 10 000 hours  
Motor supplier number ..... D509V54APRC1  
Motor Prevost number ..... 56-1939  
Brush supplier number ..... 1197  
Brush Prevost number ..... 56-1202

**Condenser fan motors**

Make ..... LeRoy-Somer  
Type ..... TAP-12  
Voltage ..... 27.5 V DC  
Current draw ..... 23 amps  
Horsepower ..... 0.57  
Revolution ..... 1950 rpm  
Insulation ..... Class F  
Motor ..... 20 000 hours  
Brush life ..... 10 000 hours  
Qty ..... 2  
Supplier number ..... 71B524/02  
Prevost number ..... 56-1558  
Brush supplier number ..... 9DB21003  
Brush Prevost number ..... 56-1914

**Main evaporator air filter**

Make ..... Permatron Corp.  
Type ..... Washable 1" X 23 3/8" X 43 1/2" Polypropylene filter  
Supplier number ..... MODEL IN-1  
Prevost number ..... 87-1051

**Driver's unit evaporator motors**

Make ..... MCC  
Voltage ..... 24 V DC  
Quantity ..... 2  
Supplier number ..... 25-0135  
Prevost number ..... 56-2167

**Driver's unit evaporator air filter**

Make ..... Permatron  
Type ..... Washable 8"X18 3/4"X1/4" Polypropylene filter  
Supplier number ..... MODEL "R"  
Prevost number ..... 87-1049



Section 22: HEATING AND AIR CONDITIONING

**Refrigerant**

Type ..... R-134a  
Quantity ..... 24 lbs (11 kg)

**Compressor**

Make ..... Carrier Transicold  
Capacity ..... 41 CFM  
Model ..... 05G-134A  
No. of cylinders ..... 6  
Bore ..... 2" (50,8 mm)  
Operating speed ..... 400 to 2200 rpm (1750 rpm, nominal)  
Minimum speed (for lubrication) ..... 400 rpm  
Nominal horsepower ..... 15  
Oil pressure at 1750 rpm ..... 15 to 30 psi (103-207 kPa)  
Oil capacity ..... 1.13 U.S. gal (4,3 liters)  
Weight ..... 142 lbs (64,5 kg)  
Approved oils  
- Castrol ..... SW 68 (POE)  
Supplier number ..... 68PD541-104-7  
Prevost number ..... 95-0239

**Compressor unloader valve**

Make ..... Carrier Transicold  
Type ..... Electric (AMC)  
Voltage ..... 24 V DC  
Watts ..... 15  
Supplier number (without coil) ..... 17-40407-20  
Prevost number (without coil) ..... 95-0095  
Coil supplier number ..... 22-50030 (1)  
Coil Prevost number ..... 95-0096

**Magnetic clutch**

Make ..... Carrier Transicold  
Type ..... Housing mounted 9" dia., 2-B grooves  
Voltage ..... 24 V DC  
Coil resistance at 68 °F (20 °C) ..... 5.15 - 5.69 ohms  
Supplier number ..... 50-01122-90  
Prevost number ..... 95-0204

**Compressor V belts**

Make ..... Dayco  
Model ..... BX 97  
Prevost number ..... 50-6664  
Qty ..... 2

**Section 22: HEATING AND AIR CONDITIONING**

---

**Condenser coil**

Make ..... Carrier Transicold

Aluminum

Supplier number..... 68BC-509--104

Prevost number ..... 45-2482

Copper

Supplier number..... 68BC-509--104-1

Prevost number ..... 45-2483

**Receiver tank (with sight glasses)**

Make ..... Standard refrigeration

Maximum pressure ..... 450 psig

Material ..... ASTM A-515

Supplier number..... 8409-19M

Prevost number ..... 87-1045

**Filter dryer assembly**

Make ..... Alco

Supplier number..... EKH 307S

Prevost number ..... 95-0231

**Moisture indicator**

Make ..... Henry

Supplier number..... MI-30-7/8S

Prevost number ..... 95-0232

**Driver's refrigerant liquid solenoid valve**

Make ..... Parker

Type ..... Normally closed with manual bypass

Nominal ..... Capacity with R-129 Tons

Voltage ..... 24 V DC

Amperage draw ..... 0.67 amps

Watts ..... 16

Supplier number (without coil) ..... RB9MP3-MM

Prevost number (without coil) ..... 95-0054

Coil supplier number ..... R23MM-CB 24 V DC

Coil Prevost number ..... 95-0055

Repair kit Prevost number ..... 95-0056

**Humidistat**

Make ..... Honeywell

Model ..... H402A

Scale range ..... 15 to 60 % relative humidity with OFF and ON position

Setting recommended ..... 30%

Sensing element ..... A thin (1 mil) moisture sensitive nylon ribbon

Supplier number ..... H402A1023

Prevost number ..... 56-1803

**Section 22: HEATING AND AIR CONDITIONING**

**Driver's hot water solenoid valve**

Make .....Asco  
Type..... Normally open (without manual bypass)  
Voltage..... 24 V DC  
Current draw .....0.47 amp.  
Watts..... 11.2  
Pressure range ..... 0 to 100 psi  
Max. temperature..... 220°F  
Supplier number (with coil) ..... 106-269-1  
Prevost number (with coil) ..... 87-0812  
Coil Prevost number ..... 87-0960  
Repair kit Prevost number ..... 87-0872

**Main hot water valve actuator**

Make ..... Honeywell  
Model .....ML 784  
Voltage..... 24 V DC  
Type.....Linear  
Prevost number ..... 64-1238  
Supplier number..... ML784A2071  
Repair kit Prevost number (packing, follower, spring stem assembly and disc)..... 64-1261  
Repair kit supplier number ..... 14 00 2695-005

**Single-seated valve**

Model ..... V5011F  
Prevost number ..... 64-1239

**Water recirculating pump**

Make ..... M.P. pumps  
Voltage..... 24 V DC  
Supplier number.....28689  
Prevost number ..... 87-1052

**Water filter**

Make ..... Parker  
Supplier number (with element) ..... 15CN1238WP  
Prevost number (with element) ..... 87-1028  
Element supplier number ..... 92-5566  
Element Prevost number ..... 87-1029

**Driver's expansion valve**

Supplier number..... 26-0190  
Prevost number ..... 95-0221

**Main expansion valve**

Make .....Alco  
Supplier number.....058613  
Prevost number ..... 95-0237

**Section 22: HEATING AND AIR CONDITIONING**

---

**Bypass solenoid water valve**

Make ..... Parker Hannifin  
Bypass supplier number ..... RB21ME7-MM  
Bypass Prevost number ..... 87-0886  
Coil supplier number ..... R-23MM24VDC-CB  
Coil Prevost number ..... 87-0886  
Repair kit supplier number ..... 76754  
Repair kit Prevost number ..... 87-0980

**Preheating system**

Make ..... Espar  
Model ..... D 12 W  
Capacity ..... 41,000 Btu/h (12 kW)  
Heating medium ..... Coolant  
Rated voltage ..... 24 V DC  
Operating voltage ..... 20-28 V DC  
Electric power consumption (without coolant recirc. pump) ..... 55 watts  
Fuel consumption ..... 0,4 U.S. gallons/hr (1,65 liters/hr)  
Supplier number ..... 25 1656 05 00 00  
Prevost number ..... 87-0969

**Preheating system**

Make ..... Webasto  
Model ..... DBW 2020  
Capacity ..... 80 000 Btu/h (23,3 kW)  
Heating medium ..... Coolant  
Rated voltage ..... 24 V DC  
Operating voltage ..... 20-28 V DC  
Electric power consumption (without coolant recirc. pump) ..... 120 watts  
Fuel consumption ..... 0,8 US gallons/hr (3 liters/hr)  
Supplier number ..... 666.640  
Prevost number ..... 87-1036



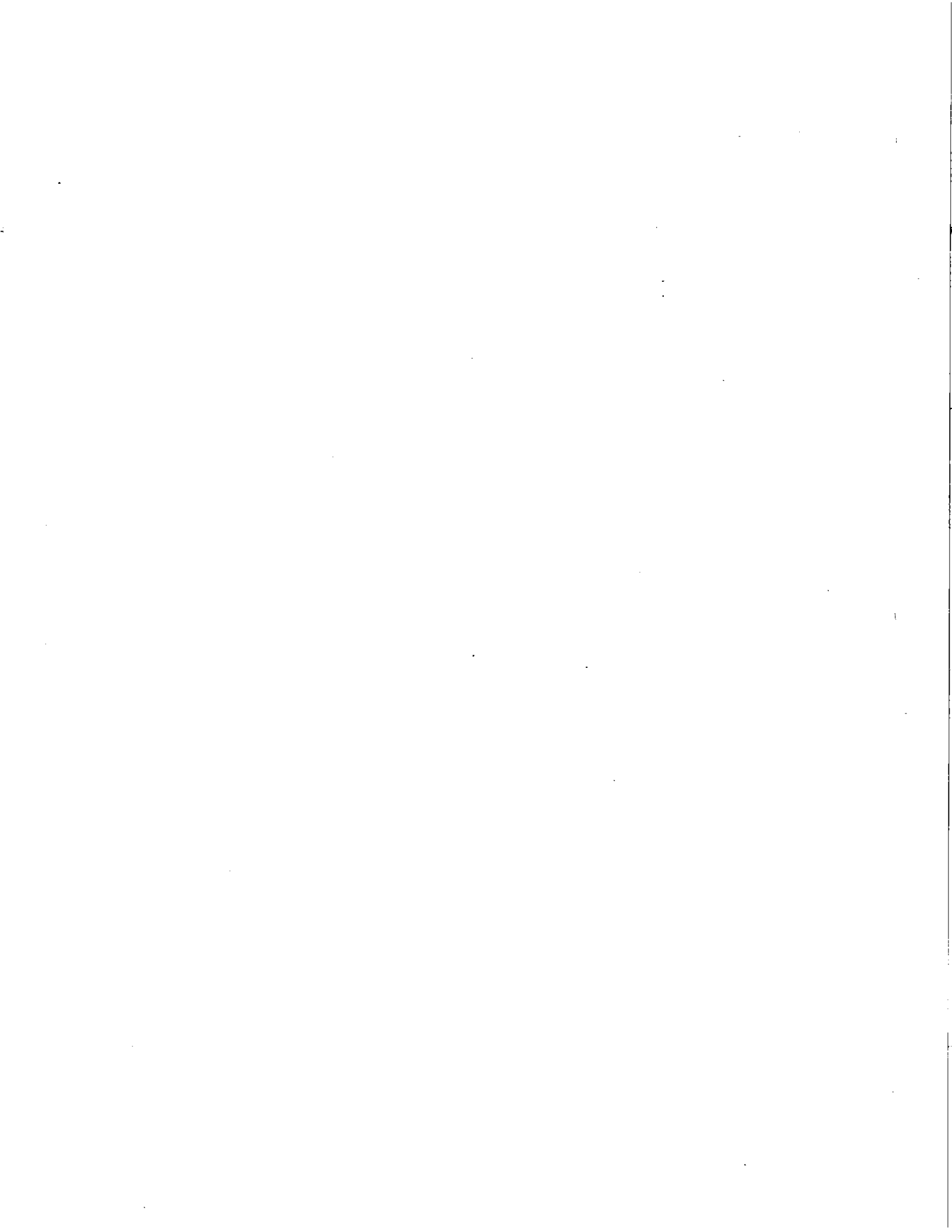



## Service Information

Number BAR-SER85-1

Date 6-14-85

Subject HOUSING-MOUNTED ELECTRIC CLUTCH

The procedure on the attached pages should be followed carefully when servicing the Carrier Transicold housing-mounted clutch. The following tools are recommended when removing and replacing this clutch:

### TOOL LIST

<u>DESCRIPTION</u>	<u>CTC PART NO. (WHERE APPLICABLE)</u>
Spanner Wrench	07-00240
Rotor Installation Tool	07-00241
Socket Bearing Retaining Nut - Large	07-00242-01
3/8" Socket Set	
Torque Wrench	
3 Leg Puller w/3 1/4-20 UNC Cap Screws	
1 - Bolt 7/8-14 UNC x 2" Long	
Feeler Gauge .020 .030 .060	
Grease Gun, Manual, 0.1 Oz Per Stroke	
Depth Gauge 0-1/2"	
Ohmmeter	

Andrew Widay  
Manager  
CTC Service Engineering

## 05G COMPRESSOR HOUSING MOUNTED CLUTCH

The new housing-mounted electric clutch, HMC, eliminates drive belt loading on the 05G crankshaft, and applies this load directly to the crankcase of the compressor. The following procedure should be followed carefully whenever it becomes necessary to remove and replace the HMC.

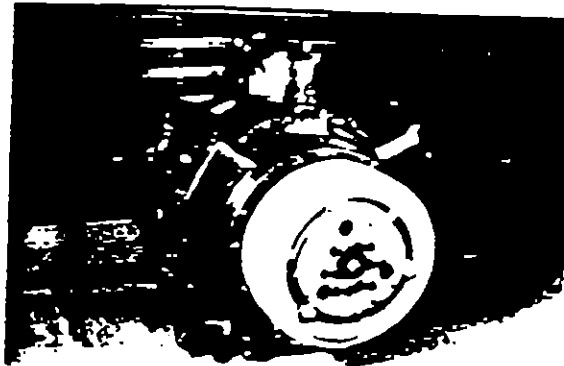

### Housing-Mounted Clutch Removal

**CAUTION:** Remove drive belt before attempting to remove clutch.

1. Remove armature as a complete assembly by removing retaining capscrew (3/8-24 x 1-1/4" Lg), lockwasher, and special 3/8 washer from compressor crankshaft. Use special CTC tool P/N 07-00240 to prevent crankshaft rotation, as shown.
2. Install a 7/8-14 x 2" capscrew into the center hole of the armature assembly. Use this capscrew as a jacking bolt to remove the armature assembly. Use tool 07-00240 as in Step 1 to prevent crankshaft rotation.

**NOTE:** Do not use a puller or pry against the armature hub or bumper plate, as this could cause damage to these parts.

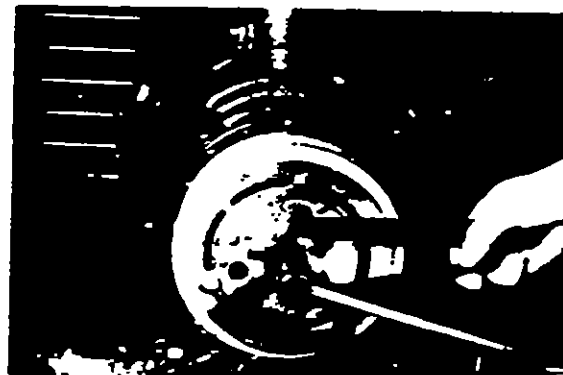
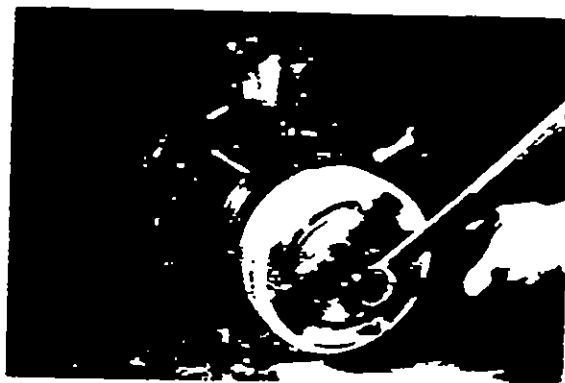



3. Remove the clutch armature assembly from the compressor crankshaft as a complete assembly, as shown.



4. Remove the rotor retaining nut with special CTC tool P/N 07-00242-01.

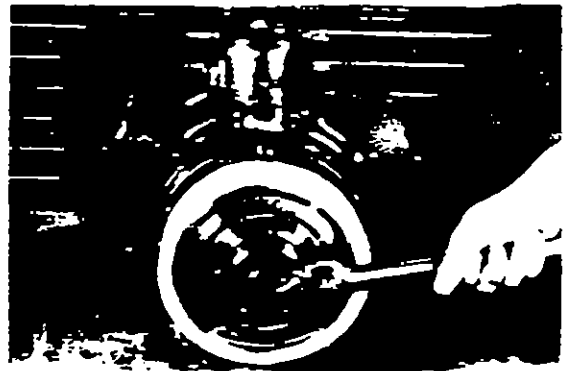
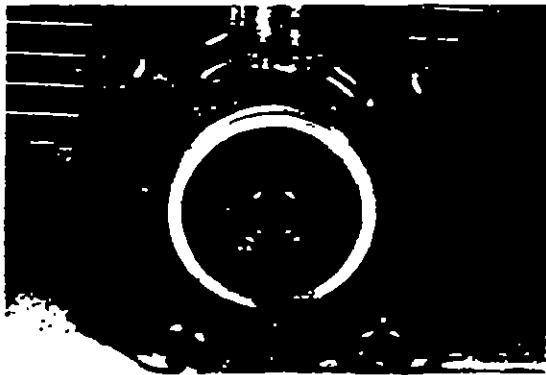

5. Install a flange-type gear puller into the three 5/16-18 tapped holes in the clutch rotor assembly, as shown.

**CAUTION:** Use a washer or other protective device to prevent damage to crankshaft and threaded hole in the crankshaft by the puller. Never use a puller in the belt grooves, as damage to the rotor may result. Use a pry bar as shown to prevent rotation of the clutch rotor.



6. Once the rotor has been pulled from the clutch bearing mounting hub, carefully lift the rotor assembly away from the compressor, as shown.

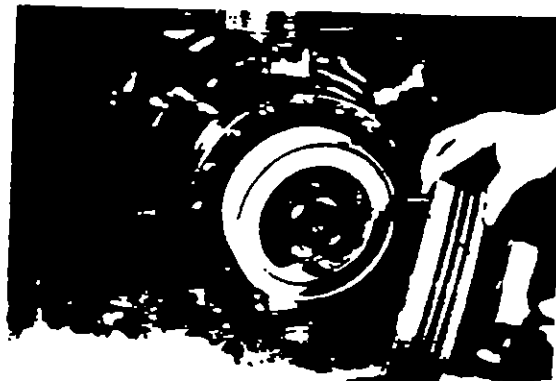

7. To remove the clutch coil, disconnect the coil's electrical cable from the wiring harness. Then remove only the three 3/8-16 capscrews holding the coil to the flange of the clutch bearing mounting hub, and carefully remove the coil, pulling straight out from the flange. Do not pry coil off, as it may bend the mounting plate.





7. After preheating bearing, slide rotor assembly onto clutch bearing mounting hub. To facilitate seating of the bearing on the hub, place CTC tool P N 07-00241 against the inner race of the bearing and tap gently with a hammer, as shown.

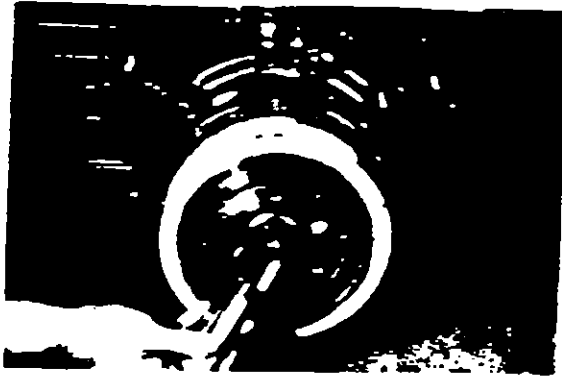

8. Install bearing retaining nut on clutch mounting hub and use torque wrench to tighten.

If the smaller nut without the grease fitting is used, torque nut to 50 ft-lb with CTC tool P/N 06-00242-02. The taper on the nut faces the bearing.

If the larger nut with the grease fitting is used, torque the nut with CTC tool P/N 07-00242-01. Due to the self-locking feature of the nut, the installation torque may vary. When installing the nut, observe the torque required to turn the nut onto the hub. After the nut seats the bearing against the hub, apply a torque 50 ft-lb greater than the installation torque.

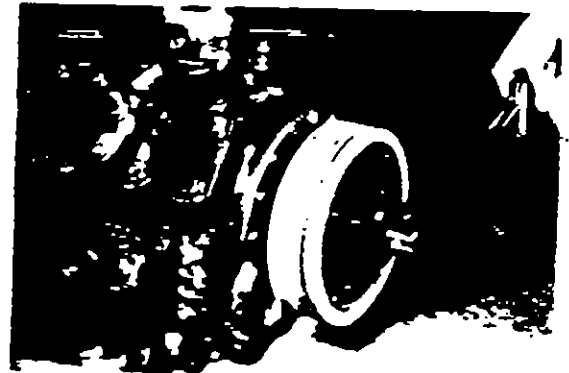

9. Check coil to rotor clearance by inserting .020 thick by .156 wide (max.) feeler gauge through an outer slot in rotor, as shown. Insert the feeler gauge so it extends beyond the rear face of the rotor and rotate the rotor one full turn. There should be no rubbing or binding.

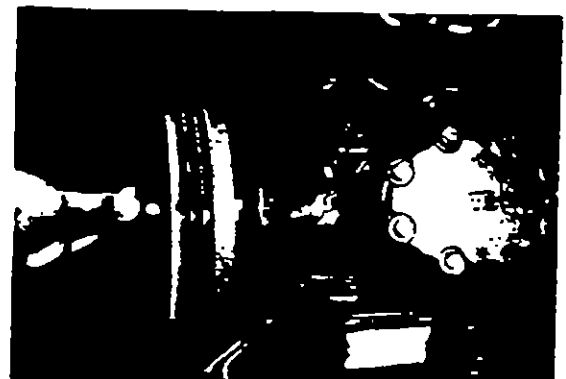

10. Place armature and hub assembly onto the compressor crankshaft and insure the hub seats on the crankshaft properly.
11. Insert the special key CTC P/N 68G2-9072 (1.75 x .250 x .199) in the keyway until outer end of key is flush with the hub's counter bore, as shown.

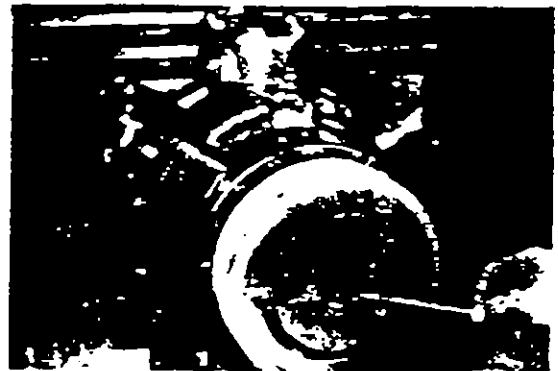

12. Secure armature assembly to crankshaft with the 3/8 special flat washer, lock washer, and 3/8-24 x 1-1/4" lg capscrew removed in Step 1 of Clutch Removal. Torque capscrew to 16-20 ft-lb using CTC tool P/N 07-00240 to prevent crankshaft rotation.

Steps 13-19 are for new clutch installation only. After the initial adjustment, shim stack should not be changed.

13. Measure the air gap between the armature and rotor surfaces, as shown.
14. Record this measurement and determine the amount of shims that must be removed to obtain a .030/.060 air gap. The shims consist of 1-.010 and 6-.020 shims.
15. Remove the six armature plate to armature hub retaining nuts and washers. Use CTC tool P/N 07-00240 to prevent armature rotation, as shown.
16. Remove the required number of shims to obtain an air gap of .030/.060.

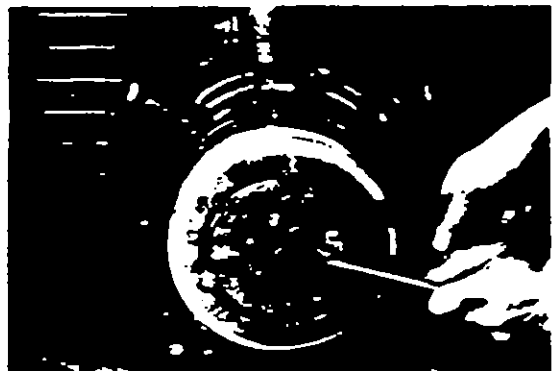
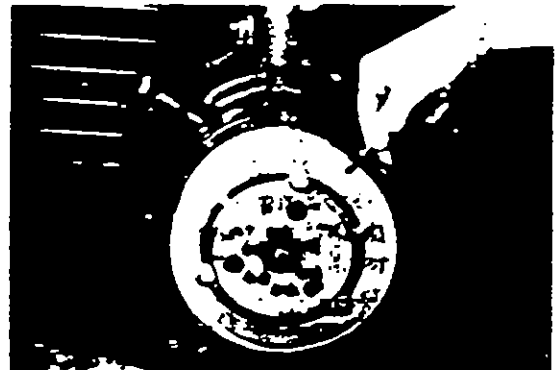

17. Insert a .020 feeler gauge between the outside edge of the clutch bearing mounting hub and the inside edge of the armature mounting hub, as shown. The clearance should be .020 or greater.

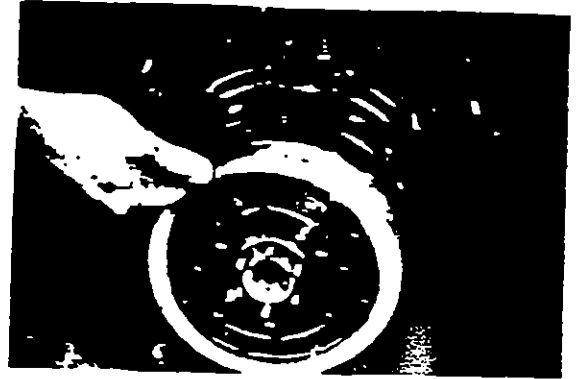

18. Reinstall armature plate, washers, and retaining nuts and torque to 7 ft-lb using CTC tool P/N 06-00240 to prevent crankshaft rotation.
19. Recheck air gap to confirm that you have obtained the .030/.060 clearance.

### FIELD SERVICE PROCEDURES

#### 1. Greasing of Clutch Bearing

The clutch bearings are pre-greased by the bearing manufacturer with the proper operating charge. Do not add grease to the bearing for at least 5000 hours of bus operation.

**CAUTION:** Overgreasing of the bearing will cause the bearing to operate at higher temperatures that may result in:

1. Blowing grease through the bearing seals onto the clutch friction faces, causing clutch slippage. A slipping clutch tends to run extremely hot, resulting in forcing more grease from the bearing, thereby increasing slippage and burning the magnetic coil.
2. Reduction in torque transmission capacity.

This is a situation where "more" is not better.

Recommended frequency for adding grease:

Up to 5000 hours bus operation	None
After initial 5000 hours	Add 0.1 oz SR1-2 grease during pre-season A/C system checkout (i.e., once per year during a Spring month)

Grease required must be "Chevron SR1-2" or CTC Engineering approved equal.

### Procedure for Adding Grease to the Clutch Bearing

The grease fitting is located in the clutch bearing retaining nut. Access to the grease fitting is accomplished by removing the armature assembly as in Steps 1, 2, and 3 of HMC Removal.

**NOTE:** The removal of the armature in order to add grease to the bearing is deliberate to insure that all grease spillage can be cleaned from the clutch, reducing the potential for clutch slippage and the resulting loss of clutch torque transmission capacity.

Any unauthorized modification of the clutch armature to facilitate greasing of the bearing will void the clutch and compressor warranties.

It is recommended that a hand operated grease gun with approximately 0.1 oz delivery per stroke be used to add grease to the bearing. Grease gun must contain "Chevron SR1-2" grease.

Wipe the grease fitting clean of all dirt and foreign materials.

Attach grease gun to grease fitting. Insert 0.1 oz grease into bearing (1 to 2 strokes of the gun).

**CAUTION:** Do not give extra strokes "for good measure" as premature clutch performance degradation may result.

After adding grease to the bearing, wipe all grease spillage from clutch faces, retaining nut, and hubs. If you can see it, wipe it up.

Reinstall armature assembly and torque retaining nut to 16-20 ft-lb torque, as in Steps 10, 11, and 12 of HMC Assembly.

## 2. Inspection for Wear

**CAUTION:** Insure bus or compressor drive engine is not operating. Take extra precautions to prevent inadvertent engine starting while clutch is being serviced.

A) With clutch coil de-energized, measure distance from face of armature to face of rotor, as shown. Feeler gauges inserted between the rotor and armature friction faces is not recommended due to the uneven wear on the friction surfaces.



Energize the clutch coil and repeat the measurement. If the difference between the first and second measurements exceeds .110 inches, the clutch rotor and armature are to be replaced.

**NOTE:** Do not attempt to readjust the armature travel by removing shims. A catastrophic clutch failure may result. After initial (new) air gap adjustment the shim stack should never be changed.

B) Never mix rotor and armature assemblies between used assemblies or new and used assemblies.

CAUTION: If either the armature or rotor assemblies are defective, both assemblies must be replaced.

C) If raised ribs on friction face are worn flat or nearly flat, replace armature and rotor assemblies.



# ANNEX TO CARRIER TRANSICOLD - COMPRESSOR MODEL 05G AND 05G BUS OPERATION AND SERVICE

## DEFINITION OF DIFFERENCES BETWEEN 37 AND 41 CUBIC INCH COMPRESSORS

The 37 and 41 cubic inch compressors are identical except for crankshaft assembly and piston. The 41 cubic inch compressor has a 0.2 inch longer stroke. This is accomplished by increasing the crankshaft "throw" by 0.1 inch. This allows the 0.2 inch stroke increase without the need to change the crankcase or connecting rod.

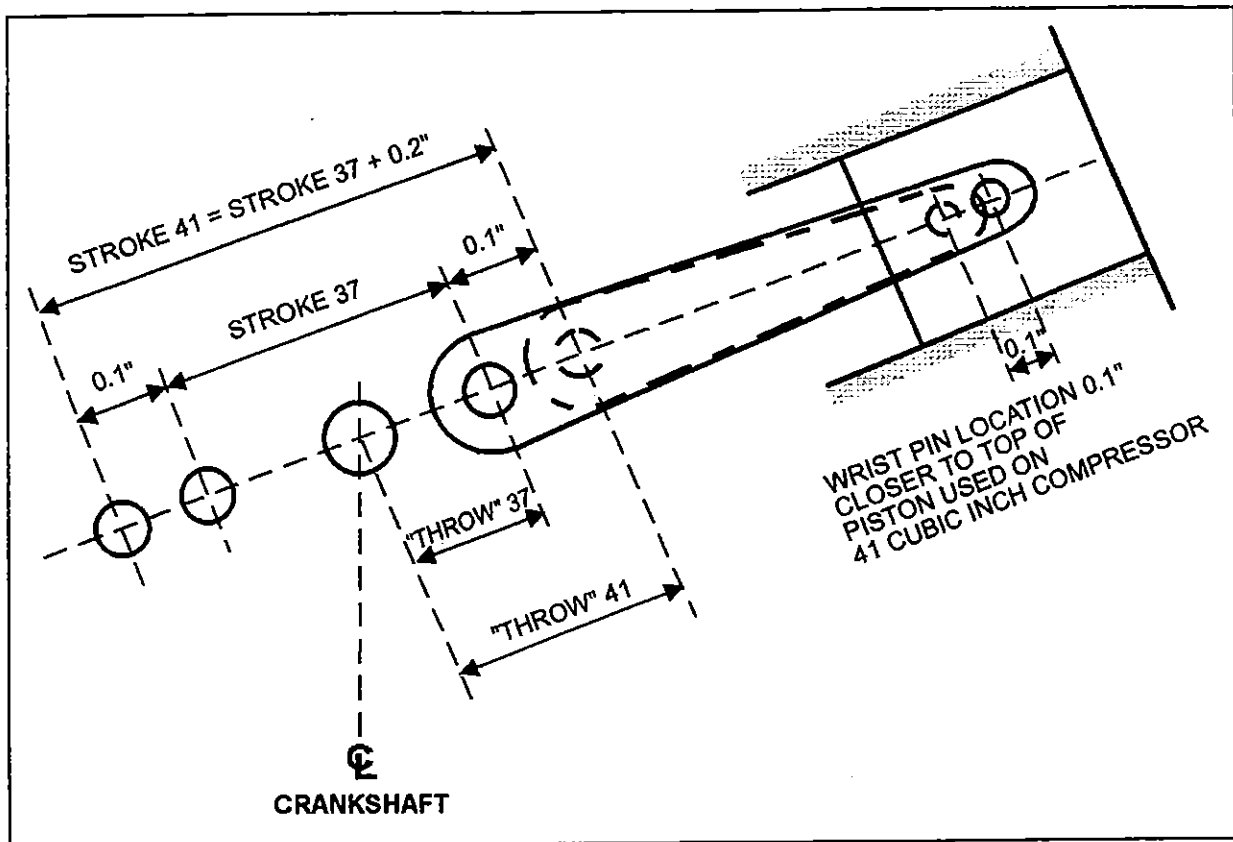

22097

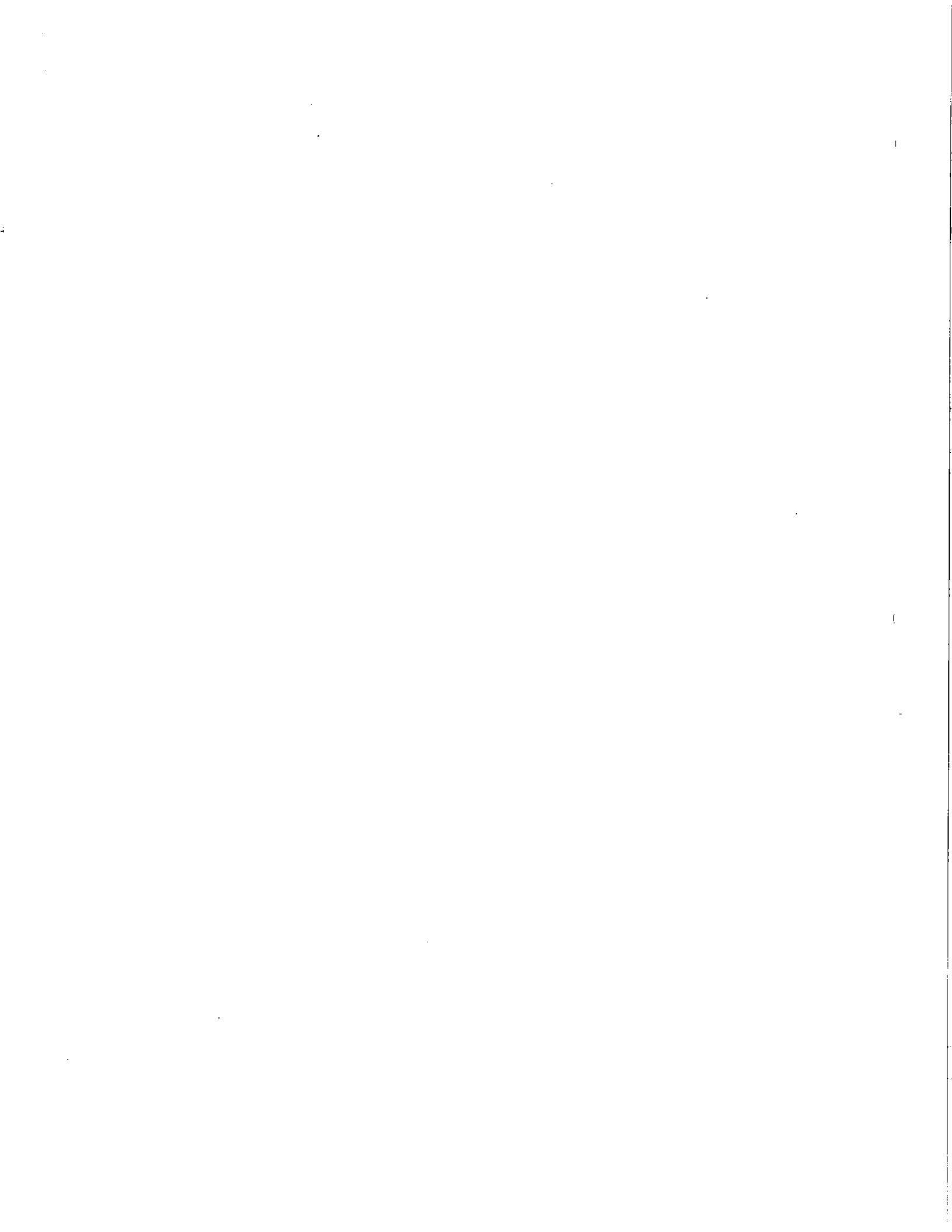

# SECTION 23: ACCESSORIES

## CONTENTS

1. HUBODOMETER.....	2
1.1 Description.....	2
1.2 Operation.....	2
1.3 Removal.....	2
1.4 Installation.....	2
2. SOUND SYSTEM.....	2
2.1 AM/FM Radio Cassette Player.....	2
2.2 Amplifier.....	3
2.3 Public Address System Control Box (PA).....	3
3. INVERTER.....	4
4. KEYLESS DOOR ENTRY SYSTEM (V.I.P. Model Only).....	4
5. BACK-UP CAMERA AND MONITOR.....	4
6. COLD-STARTING AID (ETHER).....	4
6.1 Preventive Maintenance.....	5
6.2 Troubleshooting (If System Is Non-functioning).....	5
6.3 Thermal Cutout Valve Quick Test.....	6
7. DESTINATION SIGN.....	6
7.1 Description.....	6
7.2 Maintenance.....	6
7.3 Fluorescent Replacement.....	6
7.4 Electric Motor Removal and Installation.....	7
7.5 Sign Curtain Repair.....	7
8. LAVATORY.....	7
8.1 Description.....	7
8.2 Maintenance.....	7
8.3 Ventilation Fan.....	8
8.3.1 Description.....	8
8.3.2 Maintenance.....	8
8.3.3 Removal and Installation.....	8
8.4 Door Lock.....	8
8.5 Lavatory Light.....	9
8.6 Lavatory Night-light.....	9
8.7 Emergency Buzzer.....	9
8.8 Fresh Water Tank.....	10
8.8.1 Fresh Water Tank Heater.....	10
8.9 Liquid Soap Dispenser.....	10
8.10 Flush Pushbutton.....	11
8.10.1 Pneumatic Timer Removal and Installation.....	11
8.10.2 Timer Adjustment.....	11
8.11 Flush Pump.....	11
8.11.1 Flush Pump Pressure Adjustment.....	11
9. WINDSHIELD WIPER MOTORS.....	12
9.1 Lower Windshield Wiper Motor.....	12
9.1.1 Removal and Installation.....	12
9.2 Upper Windshield Wiper Motor.....	12
9.2.1 Removal and Installation.....	12
10. SPECIFICATIONS.....	12

## 1. HUBODOMETER

### 1.1 Description

An optional wheel hubodometer (see fig. 1) may have been installed on the R.H. side of the drive axle. It indicates the total distance in miles or kilometers covered by the coach since it has left the factory, including road testing.

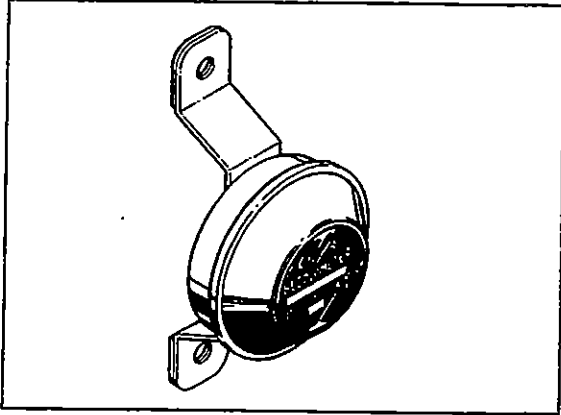

Figure 1

23027

### 1.2 Operation

The hubodometer is calibrated for a specific wheel size (diameter). Wheel rotation causes a mechanism inside the hubodometer to record distance after a predetermined number of rotations. The unit should be serviced at a competent speedometer repair facility.

### 1.3 Removal

To remove the unit, remove the two nuts and lock washers securing it to the wheel hub, and pull the unit off the studs.

### 1.4 Installation

Place the hubodometer unit over the wheel hub studs. Replace the lock washers and nuts. Torque stud nuts to 110-165 lbf•ft (150-225 N•m).

## 2. SOUND SYSTEM

Twelve (H3-41) or sixteen (H3-45) Hi-Fi speakers in passenger section, a PA system with volume control and one microphone outlet mounted in driver's area are provided as standard equipment. A "Blaupunkt" AM/FM radio cassette player, a 10 disc CD changer, two additional Hi-Fi speakers in driver's area, as well as different microphone outlets, may have been installed as optional equipment.

**Note:** Before attempting to solve an electrical problem on the sound system, refer to master wiring diagrams and to the "Sound System Troubleshooting" later in this section.

### 2.1 AM/FM Radio Cassette Player

Instructions for proper use of the radio are included in the "Blaupunkt Owner's Manual" which is provided in the technical publications box delivered with the vehicle. The radio is a serviceable component and should only be serviced by a qualified electronics technician. Refer to "Blaupunkt Service Centers" guide included in the technical publications box. Before requesting any service from a qualified technician, check the two protection fuses located in the black box behind the radio (refer to "Blaupunkt Owner's Manual" for more information).

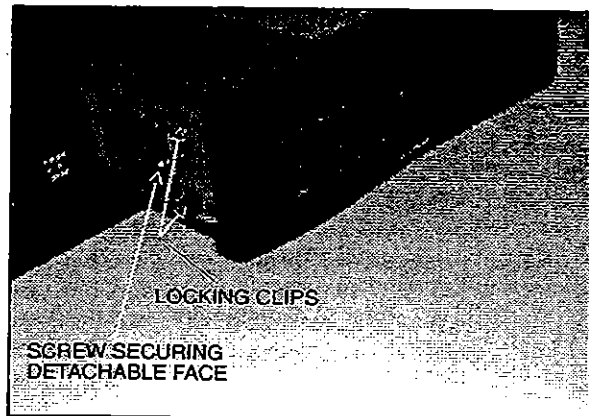

Figure 2

23028

To remove the radio from its location, proceed as follows:

1. Remove the four Phillips-head screws retaining the R.H. lower control panel to the dashboard.
2. Carefully pull out panel slightly from dashboard.
3. To unfasten the radio from its support, push in the four locking clips with pens (refer to fig. 2).
4. Disconnect all wires from radio.
5. If you need to remove face, remove screw securing detachable face (refer to fig. 2).

To reinstall, reverse removal procedure.

## 2.2 Amplifier

One (H3-41) or two (H3-45) 80 watts amplifiers are provided for the sound system. They're located over the driver's compartment and on front of the left parcel rack. Remove the amplifier(s) as follows:

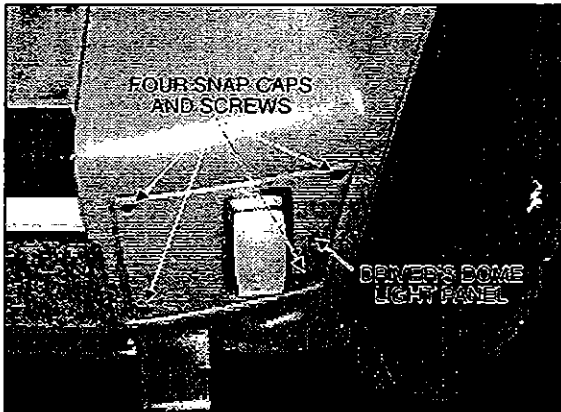

Figure 3: Driver's Dome Light Panel

23029

1. Set the battery main disconnect switch to the "OFF" position.
2. From the driver's compartment, locate the driver's dome light panel (see fig. 3).
3. Remove the four snap caps and retaining screws from the driver's dome light panel. Remove panel from its location and let it hang by the wires.
4. Disconnect wiring connectors from both sides of amplifier(s) (refer to fig. 4).

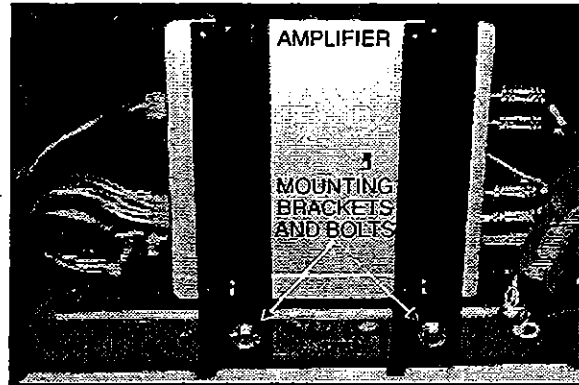

Figure 4

23030

5. Remove the two bolts and nuts retaining mounting bracket to the structure (refer to fig. 4). Then take out amplifier(s) from its (their) location.
6. Remove the four screws retaining amplifier(s) to its (their) mounting bracket.
7. Reverse the removal procedure to install the amplifier(s).

## 2.3 Public Address System Control Box (PA)

The public address system control box is located in the left corner at driver's feet. A one ampere cartridge-type fuse is mounted in an external holder of the box and may be checked without removing the box from its location (see fig. 5). To remove the fuse, unscrew the fuse cap. Remove the fuse from its holder with the cap as the cap is removed. The fuse may then be pulled out from the cap. Always replace a fuse with a fuse of the same type and rating.

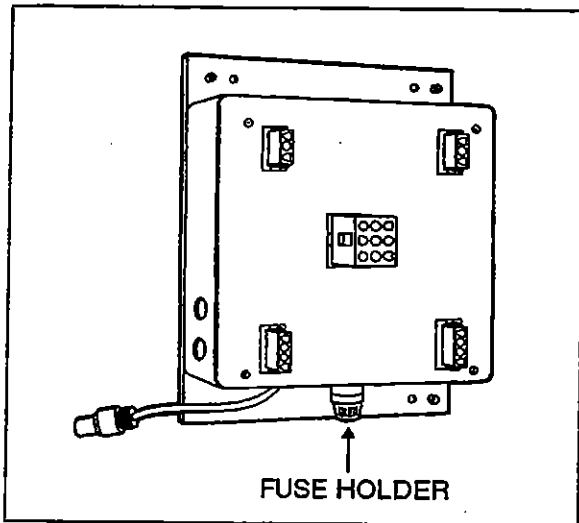

Figure 5

23031

### 3. INVERTER

The vehicles equipped with the optional video system and TV monitors are provided with an inverter which is recessed in the upper R.H. wall of the first R.H. baggage compartment. The inverter is used to convert the 12 V DC into 120 V AC. Two 40 ampere ATO fuses, easily replaceable, are mounted in the front panel external holders. A troubleshooting guide and an internal component wiring diagram of the inverter are included in the leaflets entitled "Powerverter Operating and Installation Instructions", which are included in the technical publications box delivered with the vehicle.

### 4. KEYLESS DOOR ENTRY SYSTEM (V.I.P. Model Only)

The keyless door entry system has two main components:

1. A five-button keypad on the outside panel of the entrance door.
2. An electronic microprocessor/relay module mounted on top of the defroster unit.

The factory-programmed code is permanently recorded on a plastic card (credit card size) which is supplied to the owner, and on a decal which is affixed on the electronic microprocessor/relay

module mounted on defroster unit. Owner can also select and program its own personal code (e.g. a birthday or part of a social security number) by pressing a specified sequence of keypad buttons. Refer to "Owner's Manual" for instructions on how to program a new code and for any operation information relating to the keyless door entry system.

**Caution:** Never press on the keypad buttons with a key, a pencil or any sharp object. Such objects could damage the buttons. Although each button is provided with two digits separated by a vertical line, there is only one contact per button. Press in center of button, i.e. between the two digits where there is the vertical line.

Before attempting to solve an electrical problem on the keyless door entry system, refer to wiring diagrams (V.I.P. model).

**Caution:** Do not tamper the electronic microprocessor/relay module seal during the vehicle warranty period as it will void its warranty.

### 5. BACK-UP CAMERA AND MONITOR

For information on these system, refer to wiring diagram and to Clarion manuals, located in the publication box.

### 6. COLD STARTING AID (ETHER)

The vehicle can be equipped with an electrically-operated type ether cold starting aid designed to ease engine starting when temperature is below 35 °F (2 °C).

On vehicles equipped with cold starting aid, the system consists of the main following parts:

- Ether starting aid switch
- Ether cylinder
- Solenoid valve (24 V)
- Thermal cutout valve
- Atomizer

The control rocker switch is located near the ignition switch on the L.H. lower switch panel. This switch is provided with a locking mechanism to avoid accidental use when engine is running. To activate the ether starting aid, proceed as follows:

1. Prior to cranking engine, slide down lock tab while pressing rocker switch for three seconds to fill solenoid valve.
2. Release switch to discharge shot.
3. Allow three seconds for shot to discharge.
4. Start engine, use additional shots if necessary to keep engine running.

**Caution:** This practice should be performed only when absolutely necessary. Excessive use of fluid could result in serious engine damage.

The ether cylinder and solenoid valve assembly are mounted on the engine compartment wall and are accessible from the engine compartment R.H. side door.

The thermal cutout valve is mounted on the engine (radiator side). Its function is to prevent discharge of ether when engine is warm (over 90 °F (32 °C)). An atomizer is installed on top of air intake duct (refer to fig. 6).

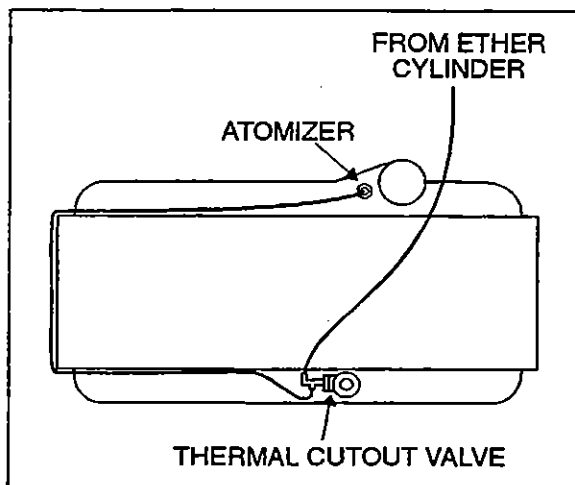

Figure 6

23032

## 6.1 Preventive Maintenance

During the summer months, remove cylinder to avoid high temperature actuation of the cylinder safety relief device. Always screw valve cap into

solenoid valve opening to prevent entrance of road dirt. When removing cylinder, be careful to prevent dirt from entering the valve.

## 6.2 Troubleshooting (If System Is Non-functioning)

**Warning:** During the following test, direct free end of tube away from personnel and all sources of ignition as this fuel is extremely flammable. Avoid breathing vapors and contacting fuel with skin. Never smoke during test.

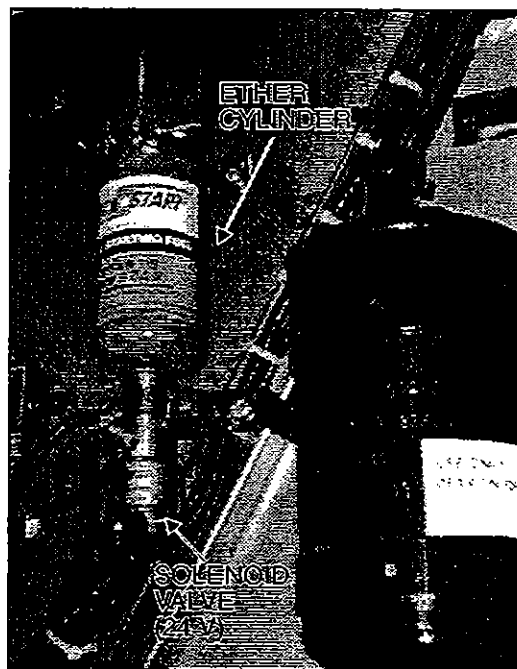

Figure 7

23033

1. Check cylinder for hand tightness and fuel supply. Empty cylinder weight is approximately 17 oz (480 g); full cylinder weight is approximately 35 oz (990 g). If cylinder is empty, replace it. Before replacing cylinder, install new valve gasket in solenoid valve.
2. If still not functioning, disconnect tubing at solenoid valve fitting. Actuate solenoid valve. (Ask an assistant to actuate solenoid valve by means of the rocker switch on the dashboard.)
  - If solenoid valve is non-functioning, check electric circuit, (refer to wiring diagrams). If sound, remove and replace the solenoid valve. If not, repair electric circuit.

- If valve is functioning, reassemble valve fitting and connect tube. Disconnect tube at thermal cutout valve from port "Tube from valve".
3. Actuate the solenoid valve.
    - If fuel is not discharged from tube, remove tube and blow out or replace.
    - If fuel is discharged, connect tube to thermal cutout valve, and disconnect other tube.
  4. Actuate the solenoid valve.
    - If fuel is not discharged, replace the cutout valve.
- Note:** *If engine coolant temperature is 90°F (32°C) or over, it is normal that fuel is not discharged as the valve is in closed position.*
- If fuel is discharged, connect tube to thermal cutout valve, and disconnect tube from atomizer.
5. Actuate the solenoid valve.
    - If fuel is not discharged from tube, fuel line is clogged. Remove tube and blow out or replace.
    - If fuel is discharged, replace the atomizer.

## 6.3 Thermal Cutout Valve Quick Test

1. Engine coolant temperature must be below 90 °F (32 °C).
2. Temporarily disconnect tube at thermal cutout valve from port "Tube to atomizer".
3. Actuate solenoid valve. (Ask an assistant to actuate solenoid valve by means of the rocker switch on the dashboard.) Fuel should be discharged through the thermal cutout valve.

**WARNING:** *Avoid breathing vapors and contacting fuel with skin. Never smoke during test.*

4. Reconnect tube to thermal cutout valve.
5. Start engine, using cold starting aid if necessary. Stop engine when it reaches operating temperature.

6. Disconnect tube at thermal cutout valve as in step 2, and repeat step 3. No fuel should be discharged.

## 7. DESTINATION SIGN

### 7.1 Description

The destination sign is located at upper front of the vehicle. The lighting is provided with a fluorescent tube which is activated by means of a rocker switch located on the L.H. side control panel. The destination sign is electrically operated. Its motor is controlled by two rocker switches mounted side by side on the destination sign. The small one determines the rolling speed without actuating it. The larger switch (momentary type) controls and actuates the rolling direction (forward or backward).

### 7.2 Maintenance

Inspect the following items regularly:

1. Check for free and easy mechanism movement.
2. Check for loose items on the sign mechanism, such as wire, loose clips, hanging tape, etc.
3. Check tension and condition of the two drive belts and replace as required.
4. Periodic lubrication is **NOT** recommended.

### 7.3 Fluorescent Replacement

1. Remove the six Phillips-head screws and washers retaining the destination sign cover, then carefully remove the cover from its location.
2. Remove both Phillips-head screws, one on each fluorescent assembly hinged bracket (see fig. 8), then lower assembly.



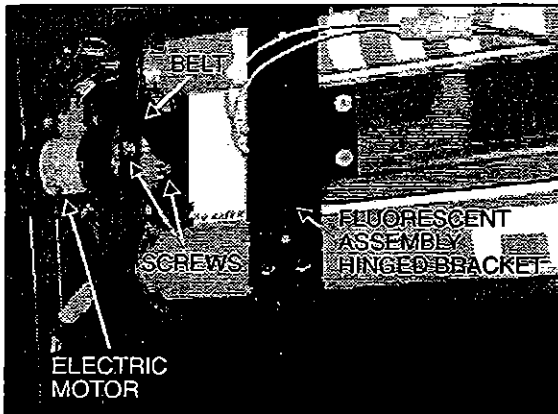

Figure 8

23034

3. Push on tab located on each fluorescent pin receptacle while removing fluorescent.
4. Install new fluorescent, then reinstall the assembly by reversing the above procedure.

## 7.4 Electric Motor Removal and Installation

To remove the electric motor, repeat previous step 1, plus the following:

1. Disconnect wires from electrical motor.
2. Remove both screws retaining motor to destination sign frame (see fig. 8).
3. Slide motor upwards, then remove the drive belt.
4. Remove motor through the opening intended for this purpose.
5. Install the motor by reversing the above procedure.

## 7.5 Sign Curtain Repair

In the event a destination sign curtain is torn, it can be repaired with 3M polyester tape or any equivalent cellophane tape. When repairing a tear, the tape should be used on both sides of the curtain.

## 8. LAVATORY

### 8.1 Description

The lavatory is located in the rear R.H. corner of coach and is equipped with the following standard items: chemical flush toilet, towel and toilet tissue dispensers, waste container, washbasin, fresh water reservoir, low temperature water safety valve, mirror, fluorescent lighting, cleaning cabinet. It may also be equipped with liquid soap and wet-type towel dispensers, an ashtray and a heating element for the fresh water reservoir, as optional equipment.

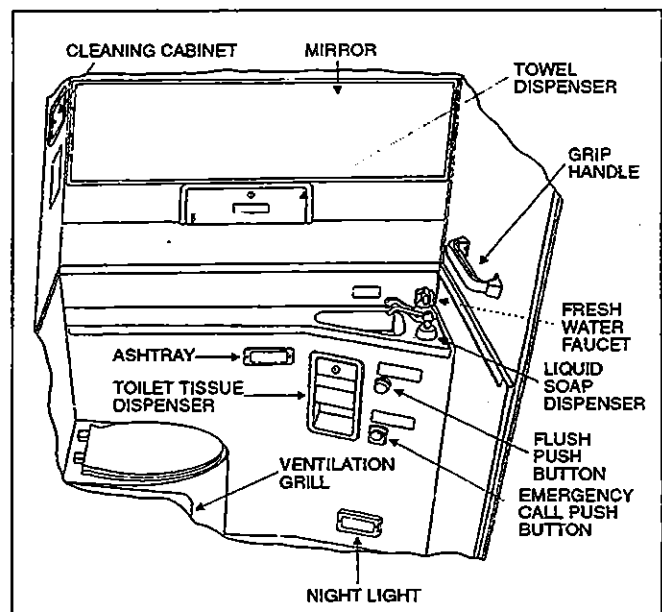

Figure 9: Lavatory

23035

Locking the door from inside will illuminate the ceiling fluorescent light plus outside signs which are mounted on the outer wall of lavatory, over the windshield and an indicator light on the L.H. dashboard. A night-light is always illuminated when ignition switch is in the "ON" position.

### 8.2 Maintenance

The servicing procedure for the lavatory is described in the "Operator's Manual" included in the technical publications box delivered with the vehicle.

## 8.3 Ventilation Fan

### 8.3.1 Description

The lavatory ventilation fan, mounted in engine compartment over the oil reserve tank, serves two purposes. It exhausts objectionable odors and provides a constant air circulation in the lavatory compartment by heating or cooling the lavatory with the vehicle ambient air. Air flows in the lavatory compartment through a vent grill located in the upper section of the lavatory door and exhausts through grills located on both sides of toilet. A series-mounted resistor (2 ohms) located in the fan outlet opening is provided to reduce noise by limiting the motor rpm.

**Note:** This fan runs constantly whenever the ignition switch on the L.H. lower control panel is in the "ON" position.

### 8.3.2 Maintenance

The frequency of preventive maintenance should be determined according to vehicle mileage and operating conditions. However, it is recommended to check this item approximately every 50,000 miles (80 000 km).

Remove fan and motor assembly. Check for fan housing wheel and motor free operation. When defective motor occurs, new motor must be installed.

**Note:** This motor is similar to those used on the driver's defroster and upper windshield defroster units.

### 8.3.3 Removal and Installation

1. With the engine compartment rear door opened, remove hose clamp securing duct to ventilator inlet, and disconnect duct.
2. Disconnect the ventilator motor wiring connector.
3. Remove the two nuts retaining the ventilator fan housing support to the square tube. Remove the ventilator assembly from its location.
4. The unit can now be disassembled and motor replaced.

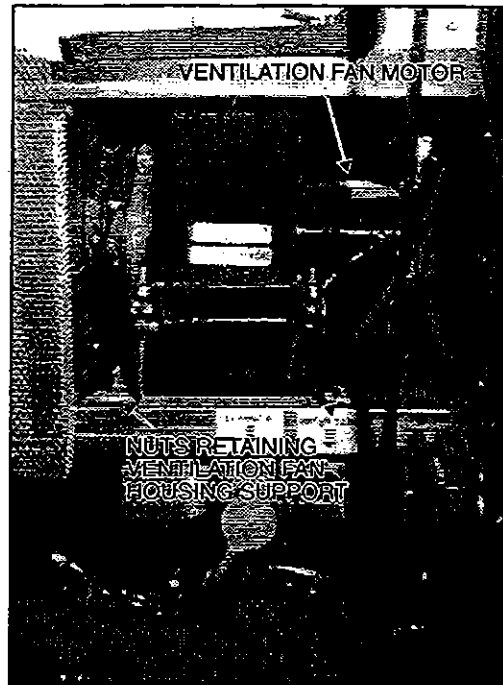

Figure 10

23006

5. Reverse previous steps to reinstall ventilator assembly on vehicle.

## 8.4 Door Lock

Lavatory door lock has inside and outside handles, as well as an inside latch to lock door from inside the compartment. If the lock fails to release, the door can be opened from the outside using a special key which is supplied to the driver. Lock assembly can be removed from the door, then readily disassembled and parts replaced, if necessary (see fig. 11). A thin coat of lubricant on all moving parts will ensure trouble-free operation.

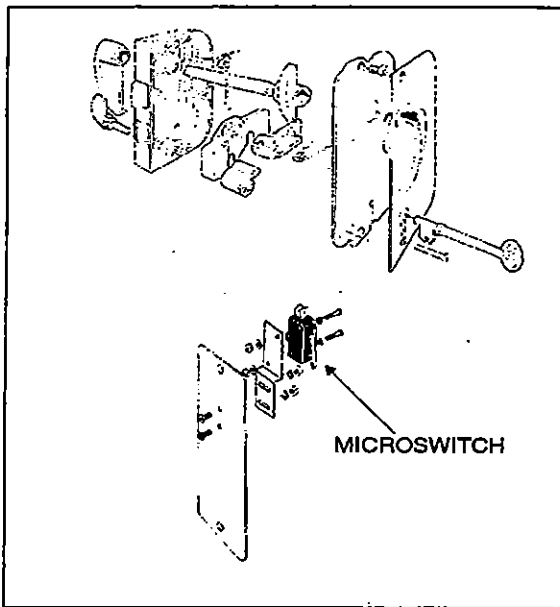

Figure 11

23037

## 8.5 Lavatory Light

The lavatory light is installed on ceiling and is provided with two fluorescent tubes. A microswitch, which is mounted in the door exterior frame, is activated by the door lock mechanism upon locking to energize the circuit. This switch is readily serviced by removing the two Phillips-head screws securing the mounting plate to the door exterior frame.

Proceed as follows to replace a fluorescent tube:

1. Press in side of lens (mirror side), free lens from its retaining groove, slide out other side, then remove lens.
2. Unsnap defective fluorescent tube by pushing both extremities simultaneously against felt discs.
3. Holding the fluorescent with one hand, push one of the pin receptacle steel plates inwards to free tube extremity, then remove tube from its fixture.
4. Reverse above procedure to install new fluorescent tube.

If ballast is defective or a wire feed voltage check is required, ballast cover may be removed by performing the previous first three steps and the following:

**Warning:** Be careful when checking the ballast feed voltage as its output voltage is 600 volts.

- a. Grasp and press both cover extremities inwards to free edges from the four rivets.
- b. Reverse previous steps to install cover, fluorescent tubes and lens.

## 8.6 Lavatory Night-light

The lavatory night-light is illuminated as soon as the ignition switch is set to the "ON" position. Proceed as follows to replace defective bulb:

1. Unscrew the two Phillips-head screws retaining the lens to the lavatory wall, and remove it.
2. Push and turn the bulb counterclockwise, and pull it out of the socket.
3. Place the new bulb into the socket. Push and turn clockwise to lock in position.
4. Place the light lens and fix in place.

## 8.7 Emergency Buzzer

The lavatory emergency buzzer is mounted on the alarm junction box in front service compartment, and sounds when the emergency call pushbutton switch in the lavatory compartment is activated. For specific wiring information, refer to wiring diagrams. To remove the emergency call pushbutton switch, proceed as follows:

1. Remove both Phillips-head screws retaining pushbutton switch plate to wall.
2. Using the appropriate key, unlock and open the toilet tissue dispenser flap. (If equipped with paper dispenser (rolls), remove the steel plate and proceed to step 5).
3. Remove all toilet tissues.
4. Unscrew the Phillips-head screw retaining the toilet tissue dispenser assembly, and remove from its location.
5. Remove switch through this opening, taking care to disconnect electric wires.

## 8.8 Fresh Water Tank

The fresh water tank located at rear of lavatory wall (under cleaning cabinet), supplies water to the washbasin by gravity. Two tubes are connected in the upper section of tank (see fig. 12). One serves as overflow as well as a vent tube and runs along the wall to the underside of the lavatory close to the engine air filter housing, while the other tube is connected to the fresh water fill valve

which is mounted over the engine oil reserve tank. A third tube connected in the lower section of fresh water tank is provided with a TEE-connector and allows fresh water to flow to the washbasin faucet and to the low temperature water safety valve for automatic or manual drainage. An access panel, located at rear of last R.H. side row of seats and secured in place with 6 Phillips-head screws, allows access to the cleaning cabinet and fresh water tank tubings, fresh water tank heater and different wiring connectors.

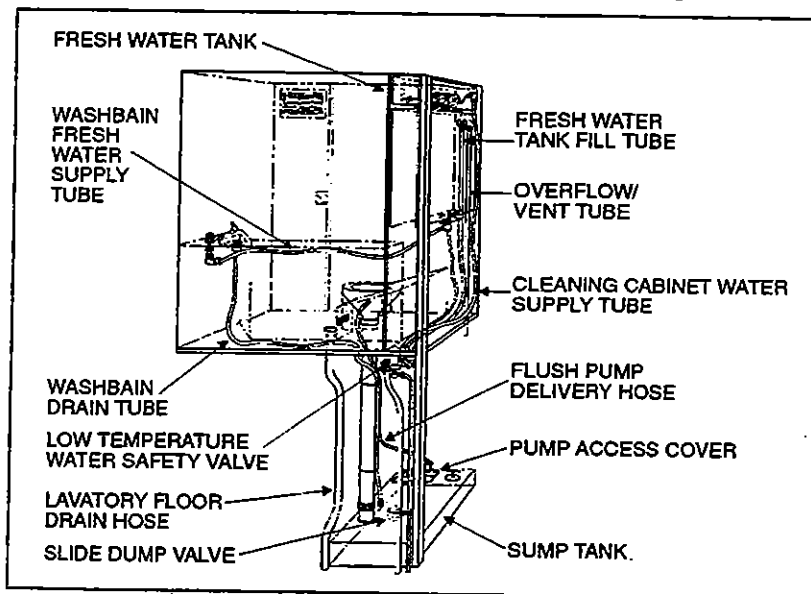

Figure 12

23038

### 8.8.1 Fresh Water Tank Heater

A 75 watt, 110 volt AC immersion-type water heater is installed in the bottom of the fresh water tank. The heated portion of element must be immersed at all times to ensure proper heater life. The heater is controlled by a toggle switch mounted on the alarm junction box in front service compartment. Its power source is provided by the 110 volt in-station connector also mounted on the alarm junction box.

## 8.9 Liquid Soap Dispenser

A liquid soap dispenser may have been installed as optional equipment. To refill dispenser, proceed as follows:

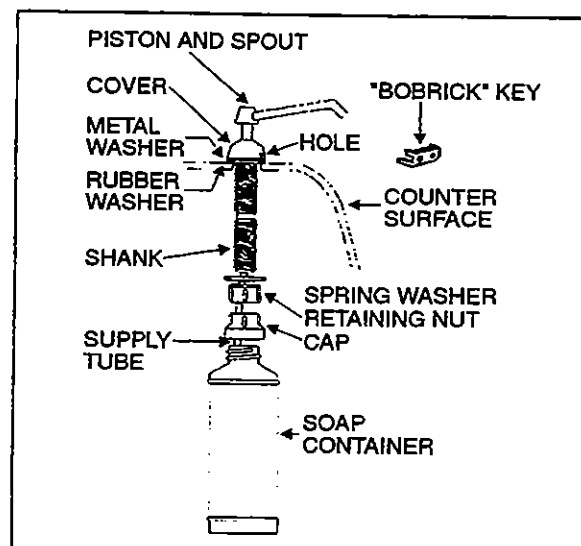

Figure 13

23039

1. Turn cover slightly clockwise until it stops.
2. Insert projection at end of "BOBRICK" key into rectangular hole in cover (see fig. 13). Push straight in. While holding "BOBRICK" key in, turn cover counterclockwise about 1/8 turn.

**Caution:** Do not use "BOBRICK" key to turn cover.

3. Lift out piston and spout, cover and supply tube.
4. Fill dispenser with soap. This model can dispense vegetable oil soaps, synthetic detergents, and lotion soaps.

**Caution:** Never use abrasive cleaners.

5. Replace supply tube, piston, and spout mechanism reversing the steps above.
6. Secure the cover by turning clockwise until lock snaps into position.

**Note:** The dispenser requires priming when extremely viscous lotion soaps are used. Remove piston and spout, cover and supply tube assembly. Pump water into assembly, then replace into dispenser.

## 8.10 Flush Pushbutton

The green flush pushbutton is located near the toilet tissue dispenser. Press on pushbutton to actuate a pneumatic timer located on the other side of wall. This timer allows an electric current flow during a preset time to a pump into the sump tank.

### 8.10.1 Pneumatic Timer Removal and Installation

1. Unscrew and remove the flush push button lock nut.
2. Using the appropriate key, unlock and open the toilet tissue dispenser flap.
3. Remove all toilet tissues.
4. Unscrew the Phillips-head screw retaining the toilet tissue dispenser assembly, and remove from its location.
5. Remove pneumatic timer through this opening, taking care to disconnect electric wires.

**Note:** Care must be taken to avoid losing the spacers installed on the mounting sleeve.

6. Reverse the above procedure to reinstall timer. The recommended torque for the lock nut is 15 lbf•ft (21 Nm).

### 8.10.2 Timer Adjustment

Timer can be adjusted from 0.2 second to 3 minutes by turning the time adjustment screw clockwise to increase time, and counterclockwise to decrease time. To gain access to the time adjustment screw, repeat steps 2, 3, and 4.

## 8.11 Flush Pump

The submersible-type flush pump is mounted inside an enclosure in the sump tank. The enclosure is provided with a screened side which serves as a strainer to prevent solid matters from entering the pump. The pump requires no periodic maintenance other than cleaning of the strainer side using a water jet introduced through the circular cap opening, once the sump tank is completely drained. The pump can run dry periodically without damage. However, for maximum seal life, the run dry periods should be kept to a minimum.

**Caution:** If vehicle is stored for an extended period of time, make sure to clean the strainer as solid matter will tend to pack, and will necessitate replacement of strainer.

### 8.11.1 Flush Pump Pressure Adjustment

The flush pump is provided with a manually-adjustable control valve mounted on the flush pump cover and serves to limit flush pump output pressure. To adjust, ask an assistant who will activate the flush pushbutton and check the liquid projection while you manually adjust the control valve.

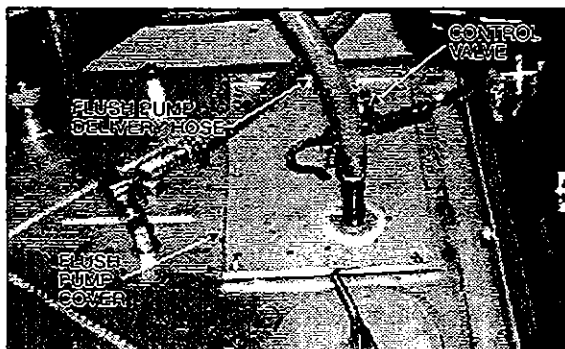

Figure 14

23040

## 9. WINDSHIELD WIPER MOTORS

### 9.1 Lower Windshield Wiper Motor

The lower windshield wiper motor is located at lower front of the vehicle, behind the defroster panel.

#### 9.1.1 Removal and Installation

**Warning:** Park vehicle safely, apply parking brake, stop engine and set battery master switch to the "OFF" position prior to working on the vehicle.

1. Remove the two phillips-head screws retaining the defroster panel, and remove it.
2. Disconnect wiring connector from the windshield wiper motor (the wiper motor is located at the left of the defroster panel).
3. Loosen the bolt retaining the lever at the end of the motor driving shaft.
4. Remove the three bolts that hold the motor to the steel plate.
5. Remove the windshield wiper motor (Prévost part #80-0304) and reverse removal procedure to reinstall.

### 9.2 Upper Windshield Wiper Motor

The upper windshield wiper motor is located above L.H. upper windshield panel. To remove the motor, it is necessary to remove left sun visor and upper windshield.

#### 9.2.1 Removal and Installation

**Warning:** Park vehicle safely, apply parking brake, stop engine and set battery master switch to the "OFF" position prior to working on the vehicle.

1. Pull out the wiring connector (black and red wires) located on left side of sun visor, and disconnect it.

2. Remove the two phillips-head screws at the bottom end of the sun visor's arms.
3. Remove the two phillips-head screws on each side of the roller, and take away the sun visor.
4. Remove the phillips-head screws retaining the upper windshield panel.
5. If equipped with blower defroster, loosen hose clamp to take off air duct from hose.
6. Disconnect wiring connector from the windshield wiper motor.
7. Loosen the bolt retaining the lever at the end of the motor driving shaft.
8. Remove the three bolts that hold the motor to the steel plate.
9. Remove the windshield wiper motor (Prévost part #80-0304) and reverse removal procedure to reinstall.

## 10. SPECIFICATIONS

### HUBODOMETER (US model: miles)

Make.....Stemco  
 Supplier number.....650-0593  
 Prévost number.....65-0002

### HUBODOMETER (Canada model: km)

Make.....Stemco  
 Supplier number.....650-0025  
 Prévost number.....65-0117

### AM/FM RADIO CASSETTE PLAYER

Make.....Blaupunkt  
 Model.....Lexington CM84  
 Power source .....12 volts  
 Maximum output power .....4 X 20 watts  
 Supplier number.....9 404 230 228  
 Prévost number.....90-0730

### AMPLIFIER

Make.....Sony  
 Model.....XM-2042  
 Power source .....12 volts  
 Total output power .....80 watts (RMS)  
 Supplier number.....XM-2042  
 Prévost number.....90-0744

**INVERTER**

Make ..... Tripp-Lite  
 Model ..... PV-750FC  
 Power source ..... 12 V DC  
 Output power ..... 750 watts/120 V AC, 60 Hz  
 Prévost number ..... 56-2292

**DESTINATION SIGN FLUORESCENT TUBE**

Make ..... General Electric  
 Length ..... 30" (76 cm)  
 Outside diameter ..... 1" (25 mm)  
 Wattage ..... 20  
 Color ..... Cool white  
 Quantity ..... 1  
 Supplier number ..... F30T8 CW4  
 Prévost number ..... 83-0120

**LAVATORY VENTILATION FAN MOTOR**

Make ..... Aurora  
 Type ..... RG500EF  
 Voltage ..... 24 V DC  
 Rotation ..... Right hand  
 Supplier number ..... 131.40.50  
 Prévost number ..... 87-0844

**LAVATORY FLUORESCENT TUBES**

Model ..... F15T8 CW  
 Length ..... 18" (45 cm)  
 Wattage ..... 15  
 Quantity ..... 2  
 Prévost number ..... 83-0102

**EMERGENCY BUZZER**

Make ..... Cole Hersee Co.  
 Voltage ..... 24 V  
 Supplier number ..... 40224  
 Prévost number ..... 56-2117

**FRESH WATER TANK**

Make ..... Prévost  
 Capacity ..... 18 US gal (68 liters)  
 Prévost number ..... 40-3030

**FRESH WATER TANK HEATER**

Make ..... Hot Watt  
 Wattage ..... 75 W  
 Voltage ..... 115 V AC  
 Supplier number ..... EM 37-5  
 Prévost number ..... 56-2018

**FLUSH PUSH BUTTON PNEUMATIC TIMER**

Make ..... Furnas  
 Type ..... Resettable  
 Time ..... 0,2 to 180 seconds  
 Supplier number ..... 55-AA  
 Prévost number ..... 90-0348

**FLUSH PUMP**

Make ..... Jabsco  
 Model number ..... 30240-0024  
 Power source ..... 24 volts  
 Capacity ..... 1750 GPH  
 Prévost number ..... 90-0496

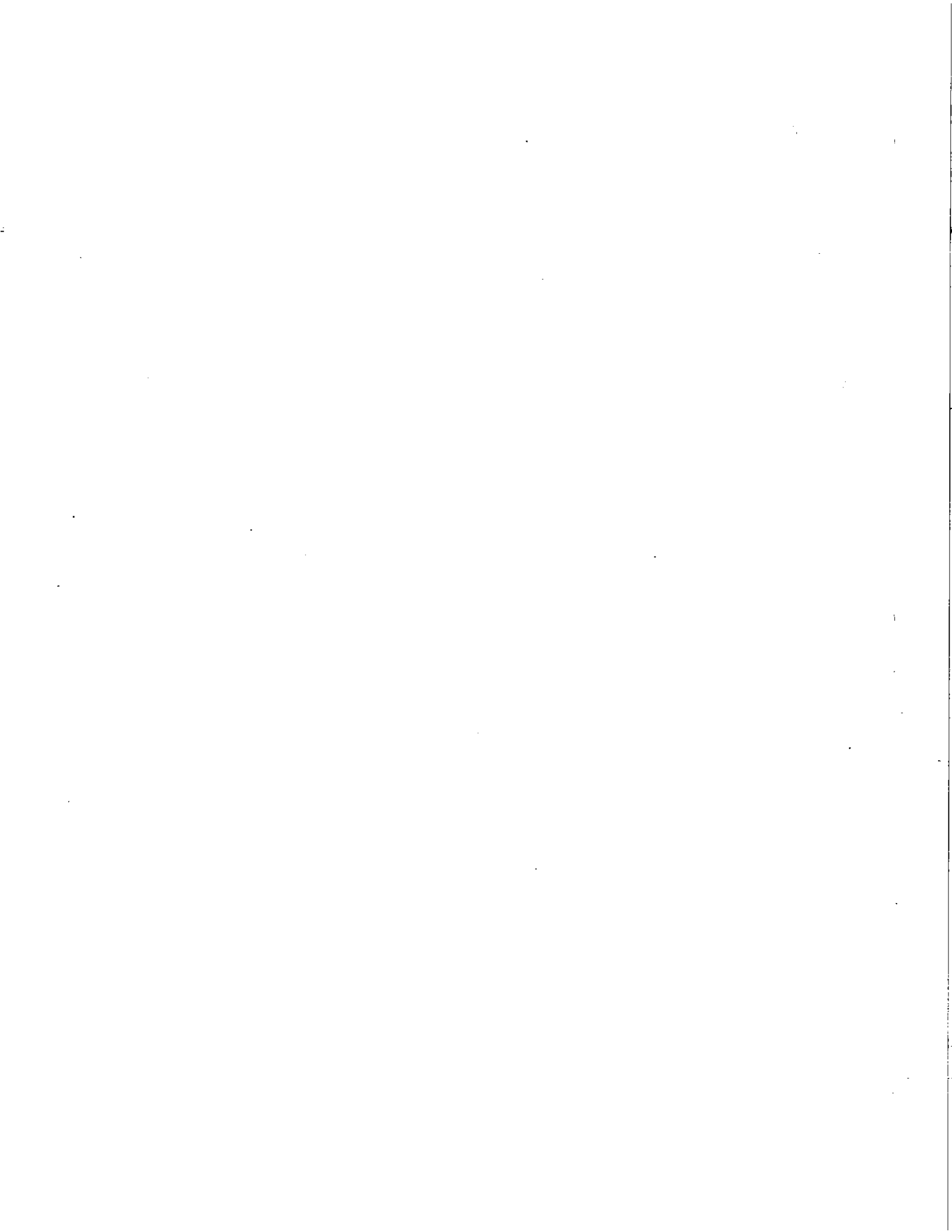





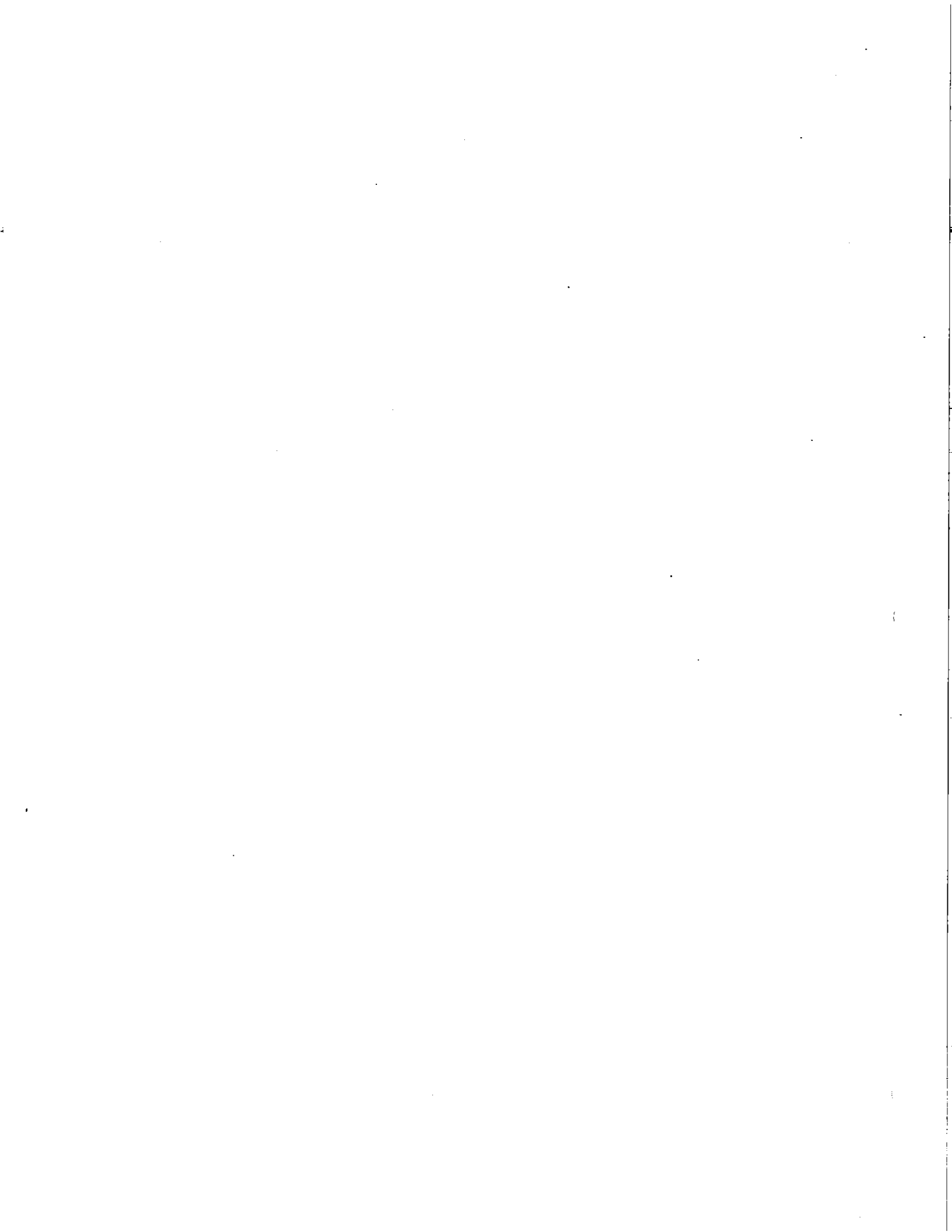

# SECTION 24: LUBRICATION

---

## CONTENTS

1. DESCRIPTION.....	2
2. BREAK-IN PERIOD MAINTENANCE .....	2
3. ENGINE OIL CHANGE .....	2
4. AUTOMATIC TRANSMISSION OIL CHANGE .....	2
5. FLEXIBLE HOSE MAINTENANCE .....	2
6. DAILY WALK-AROUND INSPECTION .....	5
6.1 Outside the Vehicle .....	5
6.2 Engine Compartment .....	5
6.3 Inside the Vehicle .....	6
7. LUBRICATION AND SERVICING SCHEDULE .....	7
7.1 Service Every 6,250 Miles (10 000 km) or Twice a Year, Whichever Comes First .....	7
7.2 Service Every 12,500 Miles (20 000 km) or Once a Year, Whichever Comes First.....	8
7.3 Service Every 25,000 Miles (40 000 km) or Once a Year, Whichever Comes First.....	8
7.4 Service Every 50,000 Miles (80 000 km) or Once a Year, Whichever Comes First.....	9
7.5 Service Every 100,000 Miles (160 000 km) or Once Every Two Years, Whichever Comes First .....	9
7.6 Miscellaneous Service .....	10
8. LUBRICANT SPECIFICATIONS .....	11
9. PART NUMBER SPECIFICATIONS .....	12

## 1. DESCRIPTION

The efficiency and life of mechanical equipment is largely dependent upon proper lubrication and servicing. All mechanical components rely on a lubrication film between the moving parts to reduce friction, prevent wear, help cool the contacting sliding parts, and keep dirt and wear particles away from mating parts. Proper lubrication depends upon using the right type of lubricant, at proper intervals and filling to proper capacities. Past experience shows that many service problems can be traced to an improper lubricant or to incorrect lubrication procedures.

A comprehensive maintenance and lubrication program is important to ensure the long service life this vehicle was designed for and to avoid costly repairs and associated downtimes caused by premature part failure. The lubrication schedule in this section gives the location of the key service points on the vehicle as well as the lubricant specifications for each component to be serviced. Specific instructions on how to check and service major components are covered in their respective sections in this maintenance manual. The recommended lubrication intervals are based on normal operating conditions and mileage accumulation. Shorten the intervals if vehicle operates in more severe conditions. Some parts and equipment referred to in the lubrication schedule are optional and may not be installed on your vehicle. Dispose of used lubricants and filters in an environmentally responsible manner, according to federal and/or local recommendations.

## 2. BREAK-IN PERIOD MAINTENANCE

Perform the following maintenance after the initial 3,000 miles (4 800 km) of operation. Then perform at the recommended intervals in the lubrication schedule.

1. Drain differential oil and refill with clean oil.\*
2. Drain manual transmission oil and refill with clean oil.\*
3. Replace standard coolant strainer\*\* and optional coolant filter/conditioner.
4. Replace automatic transmission oil filter and oil.\*
5. Lubricate front axle knuckle pins, bushings, tie rod ends, and ball studs of drag link.
6. Drain the radiator fan drive gearbox, preferably while warm, and refill with clean oil.

\* Also perform after 3,000 miles (4 800 km) following a major repair.

\*\* Also perform after 3,000 miles (4 800 km) following soldering work done at any point of the cooling system.

## 3. ENGINE OIL CHANGE

The engine oil change intervals are related to the operating conditions such as vehicle load and speed, and may vary. Prévost recommends that engine oil and filter change be performed at every 12,500 miles (20 000 km). Check the oil daily with engine stopped. If necessary, add sufficient oil to raise the level to the proper mark on the dipstick.

## 4. AUTOMATIC TRANSMISSION OIL CHANGE

Change the fluid and internal filters after the first 3,000 miles (4 800 km). Thereafter, oil and filters change should be performed every 25,000 miles (40 000 km) or once a year, whichever comes first. Note that the operating conditions may shorten the oil and filters service intervals. Fluid must be changed whenever there is evidence of dirt or high temperature condition, which would be indicated by discoloration, strong odour, or fluid analysis.

## 5. FLEXIBLE HOSE MAINTENANCE

The performance of any vehicle is directly related, among other things, to the ability of flexible hoses to supply lubricating oil, air, coolant and fuel. Maintenance of hoses is an important step to ensure efficient, economical and safe operation of the vehicle.

Check hoses daily as part of the walk-around inspection. Examine hoses for leaks, check all fittings, clamps, and ties carefully. Ensure that hoses are not resting or touching shafts, couplings, heated surfaces including exhaust manifold, any sharp edges, or other obviously damaging areas. Since all equipment vibrates to a certain extent, clamps and ties can wear with time. To ensure proper support, inspect fasteners frequently and tighten or replace them as necessary.

Investigate leaks immediately to determine if fittings have loosened or cracked, and if hoses have ruptured or worn through. Take corrective action immediately. Leaks are not only potentially detrimental to vehicle operation, but can also result in added expenses caused by the need to replace fluids.

***Warning: Personal injury and/or property damage may result from fire due to the leakage of flammable fluids, such as fuel or lube oil.***

The useful service life of a hose is determined by the temperature and pressure of the fluid within it, the time in service, its installation, the ambient temperatures, amount of flexing, and the vibration it is subjected to. With this in mind, we recommend that all hoses be thoroughly inspected at least every 50,000 miles (80 000 km) or once a year for surface damages or indication of damaged, twisted, worn, crimped, brittled, cracked, or leaking lines. Hoses having the outer surface worn through or damaged metal reinforcement should be considered unfit for further service.

It is also recommended that all hoses on this vehicle be replaced during major overhaul and/or after a maximum of five years with hoses of equal or superior quality, compared with the original.

**Section 24: LUBRICATION**

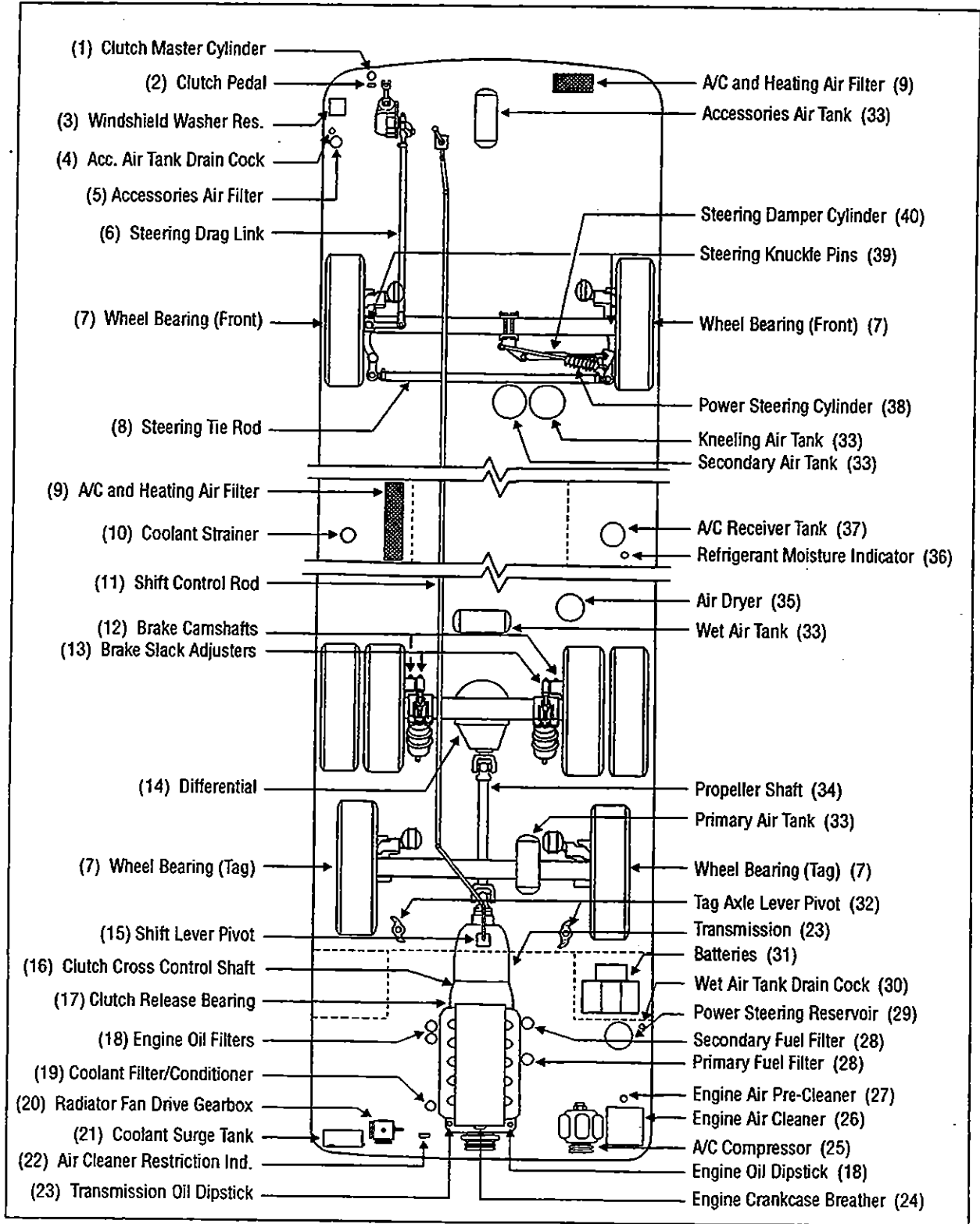

Figure 1

24002

## 6. DAILY WALK-AROUND INSPECTION

It is a good practice to make a basic visual inspection of key areas on the vehicle on a daily basis and to report any problem areas to maintenance personnel for immediate correction. For H3-45 VIP vehicle, perform this walk-around inspection before every trip.

### 6.1 Outside the Vehicle

ITEM*	DESCRIPTION
---	Check for leaks under vehicle and in engine compartment
---	Check that baggage and service compartment doors close properly
---	Inspect tires and wheels for correct tire pressure, wear or damage, and for missing wheel stud and nuts
3	Check windshield washer fluid level and add if necessary
---	Check condition of windshield wiper blades
---	Verify proper operation of all road lights, signal lights, brake lights, marker lights, and back-up lights; Replace light bulbs as required
4-30	Drain accumulated water in accessory and wet air tanks

### 6.2 Engine Compartment

ITEM*	DESCRIPTION
18	Check engine crankcase oil level; Add if necessary
23	Check transmission oil level (automatic transmission oil level can be checked from pushbutton shift selector); Add if necessary
29	Check power steering reservoir fluid level; Add if necessary
21	Check coolant surge tank fluid level; Add if necessary
28	Drain accumulated water in primary fuel filter/water separator (if equipped)
22-26	Check air cleaner restriction indicator, replace air cleaner when red signals locks in full view

\* Item numbers refer to figure 1, on page 4 of this section.

### 6.3 Inside the Vehicle

ITEM	DESCRIPTION
--	Check for proper operation of the entrance door
--	Inspect cleanliness in the steps, aisles, seating area, and lavatory
---	Check that emergency exit windows and roof escape hatches can be opened, then close all windows and hatches securely
---	Verify proper operation of windshield wiper/washer
--	Check rear view mirrors for broken glass; Adjust mirrors for adequate rear view vision
--	Start engine and check for proper operation of all gauges and indicator lights
---	Check for proper operation of electric and air horns, and back-up alarm



## 7. LUBRICATION AND SERVICING SCHEDULE

### 7.1 Service Every 6,250 Miles (10 000 km) or Twice a Year, Whichever Comes First.

ITEM*	DESCRIPTION	REMARKS	LUBRICANT &/OR PART**
26	Engine Air Cleaner	Inspect and clean, replace element if required	Filter: #53-0197
27	Engine Air Pre-cleaner	Check discharge tube	-----
25	A/C Compressor	Check oil level, add if necessary	Polyolester Oil
37	A/C Receiver Tank	Check refrigerant level, add if necessary	HFC 134a
36	Refrigerant Moisture Indicator	Replace filter dryer unit according to moisture indicator	Filter: #45-2497
14	Differential	Check oil level, add if necessary	Multigrade gear oil
20	Radiator Fan Drive Gearbox	Check oil level, add if necessary	Synthetic oil: ISO VG 460
34	Propeller Shaft	Grease one fitting on each universal joint and one fitting on slip joint	Multi purpose grease
32	Tag Axle Lever Pivot	Grease one fitting on each pivot	Multi purpose grease
13	Brake Slack Adjuster	Grease one fitting on each slack adjuster (drive axle only)	Multi purpose grease
40	Steering Damper Cylinder	Grease one fitting at cylinder rod end	Multi purpose grease
38	Power Steering Cylinder	Grease one fitting at each cylinder end	Multi purpose grease
39	Steering Knuckle Pins	Grease two fittings on each knuckle	Multi purpose grease
8	Steering Tie Rod Ends	Grease one fitting at each end	Multi purpose grease
6	Steering Drag Link Ends	Grease one fitting at each end	Multi purpose grease
15■	Shift Lever Pivot	Grease one fitting	Multi purpose grease
16■	Clutch Cross Control Shaft	Grease three fittings	Multi purpose grease
17■	Clutch Release Bearing	Grease one fitting	Multi purpose grease

\* Item numbers refer to figure 1, on page 4 of this section.

\*\* See end of this section for lubricant and part number specifications.

■ With manual transmission only.

**7.2 Service Every 12,500 Miles (20 000 km) or Once a Year, Whichever Comes First.**

ITEM*	DESCRIPTION	REMARKS	LUBRICANT &/OR PART**
18	Engine	Change oil and filters	Engine oil: SAE 15W40, API CF4 Filters: #51-0458
28	Fuel Filters	Change primary and secondary fuel filters (Fill with clean fuel before installation)	Primary: #51-0137 Prim. w/sep.: #53-1390 Secondary: #51-0128
19	Coolant Filter/Conditioner	Replace element	Filter: #55-0630
21	Coolant Surge Tank	Test coolant solution	-----
33	Air Tanks	Drain accumulated water in all tanks	-----
9	A/C and Heating Air Filters	Clean or replace two elements	Driver's: #87-1049 Passenger's: #87-1051
1■	Clutch Master Cylinder	Check oil level	Brake Fluid (DOT 3)

**7.3 Service Every 25,000 Miles (40 000 km) or Once a Year, Whichever Comes First.**

ITEM*	DESCRIPTION	REMARKS	LUBRICANT &/OR PART**
23	Automatic Transmission	Change oil and filters	Dexron-II E or Dexron-III
2■	Clutch Pedal	Check and adjust if necessary	-----
11■	Shift Control Rod Universal Joints	Grease four fittings	Multi purpose grease

\* Item numbers refer to figure 1, on page 4 of this section.

\*\* See end of this section for lubricant and part number specifications.

■ With manual transmission only.

### 7.4 Service Every 50,000 Miles (80 000 km) or Once a Year, Whichever Comes First.

ITEM*	DESCRIPTION	REMARKS	LUBRICANT &/OR PART**
23■	Manual Transmission	Change oil	Engine oil: SAE 30, 40, 50 or Gear oil: SAE 80, 90
20	Radiator Fan Drive Gearbox	Change oil	Synthetic oil: ISO VG 460
29	Power Steering Reservoir	Replace oil filter cartridge element	Cartridge: #66-0987
7	Front and Tag Axle Bearings	Repack with grease	Multi purpose grease
10	Coolant Strainer	Check and clean, change cartridge if required	Cartridge: #87-1029
24	Engine Crankcase Breather	Clean breather steel mesh	————
—	Flexible Hose	Thoroughly inspect all hoses (see p.24-2)	————

### 7.5 Service Every 100,000 Miles (160 000 km) or Once Every Two Years, Whichever Comes First.

ITEM*	DESCRIPTION	REMARKS	LUBRICANT &/OR PART**
14	Differential	Change oil; Clean breathers	Multigrade gear oil
5	Accessories Air Filter	Change filter element	Filter: #64-1252
35	Air Dryer	Change cartridge	Cartridge: #64-1278
12	Brake Camshaft	Grease one fitting on each drive axle drum brake	Multi purpose grease
1■	Clutch	Drain oil and refill	Brake Fluid (DOT 3)

\* Item numbers refer to figure 1, on page 4 of this section.

\*\* See end of this section for lubricant and part number specifications.

■ With manual transmission only.

### 7.6 Miscellaneous Service

ITEM*	DESCRIPTION	REMARKS	LUBRICANT &/OR PART**
21	Cooling System	Drain, flush and refill every two years or 200,000 miles (320 000 km) whichever comes first	Engine coolant
31	Battery Terminals	Clean and coat terminals yearly	Battery terminal coating
—	Discharge Tubes***	Every three months: Check 2 condenser's discharge tubes Check 6 evaporator's discharge tubes Check 2 front discharge tubes	-----

\* Item numbers refer to figure 1, on page 4 of this section.

\*\* See end of this section for lubricant and part number specifications.

\*\*\* Discharge tubes are rubber tubes located under vehicle.

## 8. LUBRICANT SPECIFICATIONS

ITEM*	DESCRIPTION	SPECIFICATIONS
4	Engine Oil	SAE Viscosity Grade: 15W40 API Classification: CF4
29	Power Steering Oil	Automatic Transmission Oil (Dexron-II-E or Dexron-III)
21	Engine Coolant	Low silicate, ethylene glycol coolant 50% antifreeze/water solution is normally used Antifreeze concentration should be between 30% and 67%
25	A/C Compressor Oil	Polyolester Oil, HFC 134a compatible: Castrol SW-68 (POE) or equivalent
14	Differential Oil	Multigrade gear oil meeting MIL-L-2105-D: 75W90 for Northern climate 80W140 for Southern climate (In extreme conditions or for better performance, full synthetic gear oil can be used.)
20	Fan Gearbox Oil	Synthetic oil: ISO VG (viscosity grade) 460 Mobil SHC 634 or equivalent
23	Automatic Transmission Oil	Dexron-II-E or Dexron-III
23	Manual Transmission Oil	Heavy-duty engine oil meeting MIL-L-2104-C: SAE 30 (Northern climate), SAE 40, SAE 50 Straight mineral gear oil: SAE 80 (Northern climate), SAE 90
1	Clutch Oil	Heavy-duty brake fluid meeting DOT 3 specifications
--	Multi Purpose Grease	Good quality lithium-base grease: NLGI No.2 Grade is suitable for most temperatures NLGI No.1 Grade is suitable for extremely low temperatures

\* Item numbers refer to figure 1, on page 4 of this section.

## 9. PART NUMBER SPECIFICATIONS

ITEM*	DESCRIPTION	PRÉVOST NO	SUPPLIER NO
18	Engine Oil Filters	#51-0458	Detroit Diesel: 25014505 AC Rochester Div. GM: PF2100
29	Power Steering Reservoir Oil Filter	#66-0528	Garrison Hydraulic: 32516
26	Engine Air Cleaner Filter	#53-0197	Nelson: 70337-N Baldwin: PA-2839 Donaldson: P52-2874 Fram: CA-7113
36	Refrigerant Filter Dryer Unit	#45-2497	Alco Controls: EKH 307S (modified)
28	Engine Primary Fuel Filter	#51-0137	Detroit Diesel: 25014274 AC Rochester Div. GM: TP-915D
28	Engine Primary Fuel Filter with Water Separator (optional)	#53-1390	Detroit Diesel: 25011910 AC Rochester Div. GM: TP-1057
28	Engine Secondary Fuel Filter	#51-0128	Detroit Diesel: 25014342 AC Rochester Div. GM: TP-916D
19	Engine Coolant Filter/Conditioner	#55-0630	Detroit Diesel: 23507545 Nalco Chemical Company: DDF3000
9	A/C and Heating Driver's Air Filter	#87-1049	Permatron Corp.: Model "R"
9	A/C and Heating Passenger's Air Filter	#87-1051	Permatron Corp.: Model IN-1
23	Automatic Transmission Oil Filter Kit	#57-1687	Allison: 29503829
10	Coolant Strainer	#87-1029	Parker: 925566
5	Accessories Air Filter	#64-1252	Cowper (Norgren): 2992-18
35	Air Dryer Cartridge	#64-1278	Rockwell Wabco: S 432 923 2

\* Item numbers refer to figure 1, on page 4 of this section.



1111