

PREVOST

XL Series Motorcoach

TABLE OF CONTENTS

| | | |
|--|--------------|--|
| FOREWORD | 1 - 1 | Engine compartment components2 - 34 |
| CONTROLS/INSTRUMENTS | 2 - 1 | Baggage compartment2 - 35 |
| Keys..... | 2 - 1 | Spare wheel & tire compartment2 - 35 |
| Main battery disconnect switch..... | 2 - 2 | A/C & heating and condenser compartment doors..... |
| Fuel tank filling..... | 2 - 2 | Service doors2 - 36 |
| Controls and instrument panels..... | 2 - 3 | L.H. side rear service compartment and main power compartment2 - 36 |
| L.H. side control panel..... | 2 - 4 | Battery compartment..... |
| Cruise control switches..... | 2 - 6 | Interior compartments..... |
| Dashboard (without tachograph)..... | 2 - 9 | Lavatory..... |
| Dashboard (with tachograph)..... | 2 - 10 | Parcel racks..... |
| Dashboard indicator/warning lights..... | 2 - 11 | Safety equipment compartment..... |
| L.H. lower switch panel..... | 2 - 15 | Accessories..... |
| R.H. lower switch panel..... | 2 - 16 | Preheating system timers (auxiliary)..... |
| R.H. console..... | 2 - 16 | |
| Detroit diesel PRODRIVER™ controls..... | 2 - 17 | SAFETY |
| R.H. lateral console..... | 2 - 20 | 3 - 1 |
| Automatic transmission..... | 2 - 21 | Brakes..... |
| Manual transmission..... | 2 - 23 | Antilock braking system (ABS)..... |
| Steering column controls..... | 2 - 24 | Air system emergency fill valve..... |
| Foot-operated controls..... | 2 - 25 | Back up alarm..... |
| Tilt steering wheel and telescopic steering column..... | 2 - 26 | Kneeling system..... |
| Entrance door..... | 2 - 26 | Hi-buoy system..... |
| Seats..... | 2 - 27 | Low-buoy system..... |
| Driver's seat..... | 2 - 28 | Emergency exits..... |
| Seat belts..... | 2 - 28 | Day time running lights..... |
| Passenger seats..... | 2 - 29 | Fog lights..... |
| Tour guide seat..... | 2 - 29 | Horns..... |
| Mirrors..... | 2 - 29 | Alarm system..... |
| Exterior compartments (XL-40)..... | 2 - 31 | Safety equipment..... |
| Exterior compartments (XL-45)..... | 2 - 32 | Safety precautions..... |
| Engine compartment doors..... | 2 - 33 | Defensive driving..... |
| Engine air intake ducts..... | 2 - 33 | |
| Fuel tank filling door..... | 2 - 33 | |
| Entrance door..... | 2 - 33 | |

PREVOST**XL Series Motorcoach
CONTROLS/INSTRUMENTS****KEYS**

Depending on optional equipment, up to eight (8) different key models may have been supplied with your vehicle. They are used as described below;

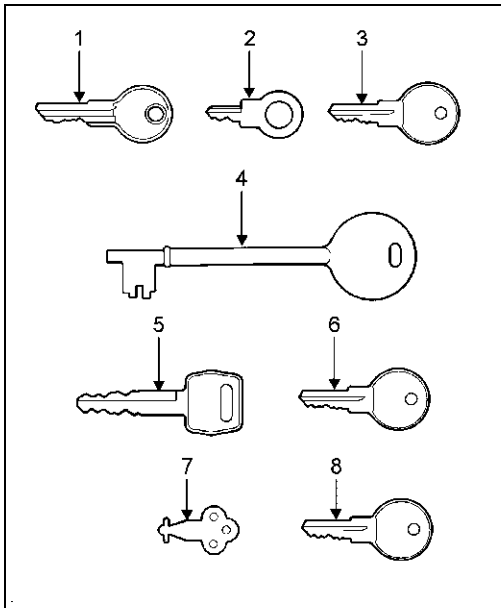

23014

1. Ignition switch.
2. Tachograph.
3. Towel dispenser.
4. Lavatory door lock.
5. Entrance door lock.
Baggage compartments door lock.
Front electric compartment door lock.
Steering compartment door lock.
Rear service compartments door lock (XL-45 only).
Main power compartment (XL-45 only).
- NOTE:** *Baggage doors can also be remotely locked/unlocked using the Central Locking System Switch, located on L.H. Side Control Panel.*
6. Video system compartment door lock.
7. Toilet tissue dispenser.
8. Moist towel dispenser.

NOTE: *For added security, record the key numbers and keep this information in a safe place. Do not keep these records inside vehicle. It is also advisable to deposit a duplicate of each key in a safe place, so they can be obtained without difficulty in case of an emergency or loss.*

MAIN BATTERY DISCONNECT SWITCH

XL-40

The manual switch which disconnects both the 12 and 24 volt systems is located next to the R.H. Side Rear Baggage Compartment door.

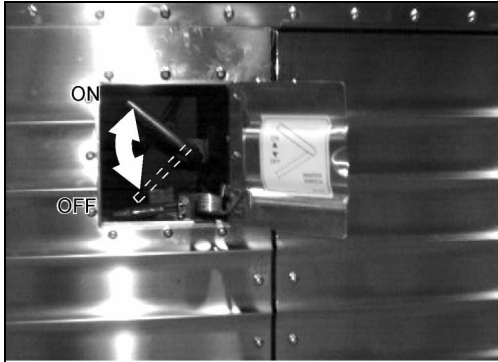

06047

XL-45

The toggle switch which disconnects both the 12 and 24 volt systems is located on back wall of Main Power Compartment. Use this switch for maintenance purposes only. The remote battery master switch which also disconnects both 12 and 24 volt systems is located on L.H. lower switch panel (see item #2 on page 2-15).

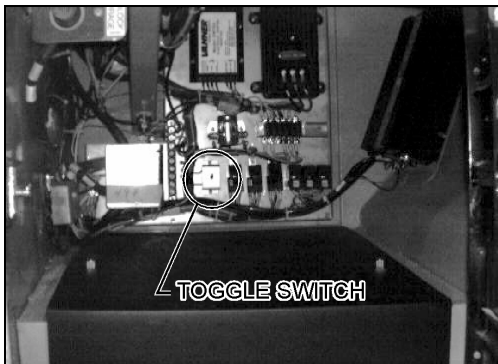

06102

CAUTION: When vehicle is parked overnight or for an extended period of time, main battery disconnect switch (XL-40) or battery master switch (XL-45) (see page 2-15) should be set to the "OFF" position in order to avoid battery voltage imbalance.

NOTE: When battery disconnect switch (XL-40) or battery master switch (XL-45) is set to the "OFF" position, the electrical supply from the batteries is cut off, with the exception of the Fire Detection System, the Engine & Transmission Electronic Controls, the Auxiliary Heating System, the Battery Equalizers and the Digital Clock.

FUEL TANK FILLING

On **XL-40** vehicles, fuel filler neck is accessible by opening a small door located amidships, on R.H. side of vehicle.

On **XL-45** vehicles, fuel filler necks are accessible by opening a small door located amidships, on either R.H. or L.H. side of vehicle.



18013

NOTE: Provided vehicle is parked level, an automatic nozzle will shut off when tank is filled to approximately 95% capacity.

CAUTION: Do not fill to more than 95% of fuel tank capacity. Do not "top off" the tank; doing so may result in fuel spillage when the fuel expands.

CONTROLS AND INSTRUMENT PANELS

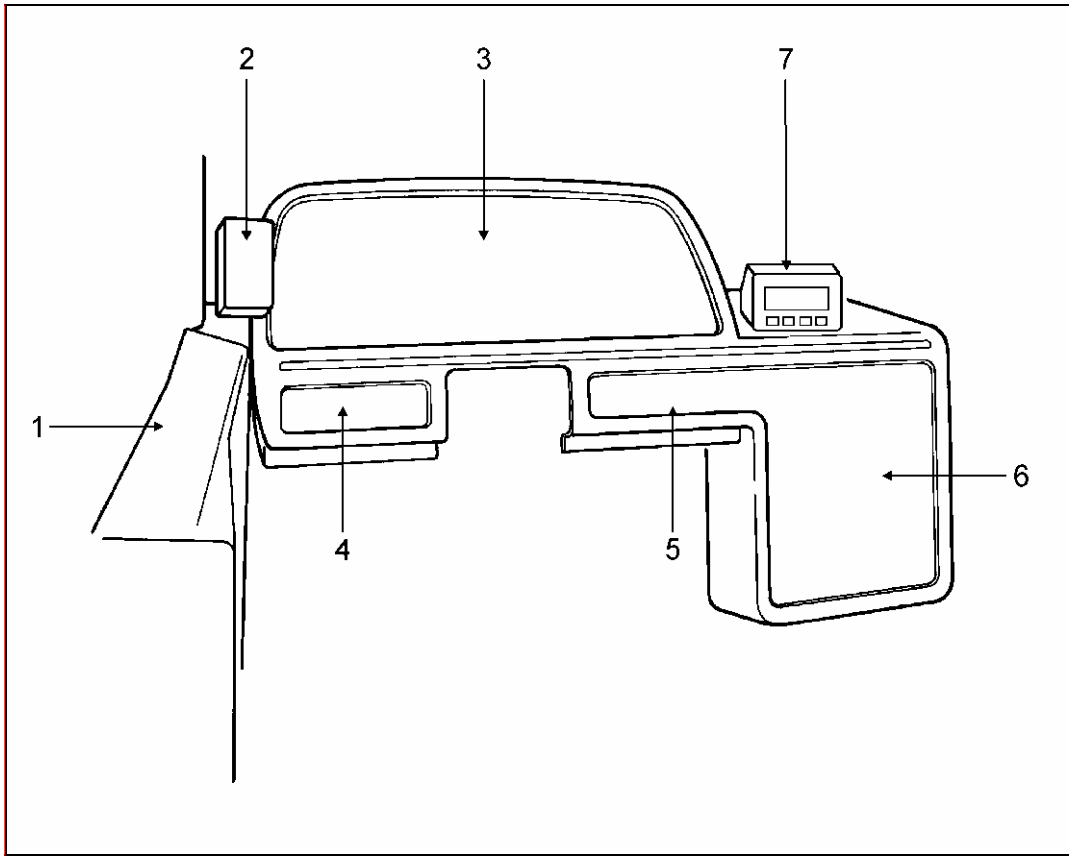

Commentaire :

8114

| No. | Panel | Pg. | No. | Panel | Pg. |
|-----|---|-------------|-----|---------------------------------------|------|
| 1 | L.H. Side Control Panel | 2-4 | 5 | R.H. Lower Switch Panel | 2-16 |
| 2 | Video System Remote Control | 2-7 | 6 | R.H. Console | 2-17 |
| 3 | Dashboard (without Tachograph) Dashboard (with Tachograph) | 2-9 2-10 | 7 | Detroit Diesel PRODRIVER™ Controls | 2-18 |
| 4 | L.H. Lower Switch Panel | 2-15 | 8 | R.H. Lateral Console (not shown) | 2-20 |

L.H. SIDE CONTROL PANEL

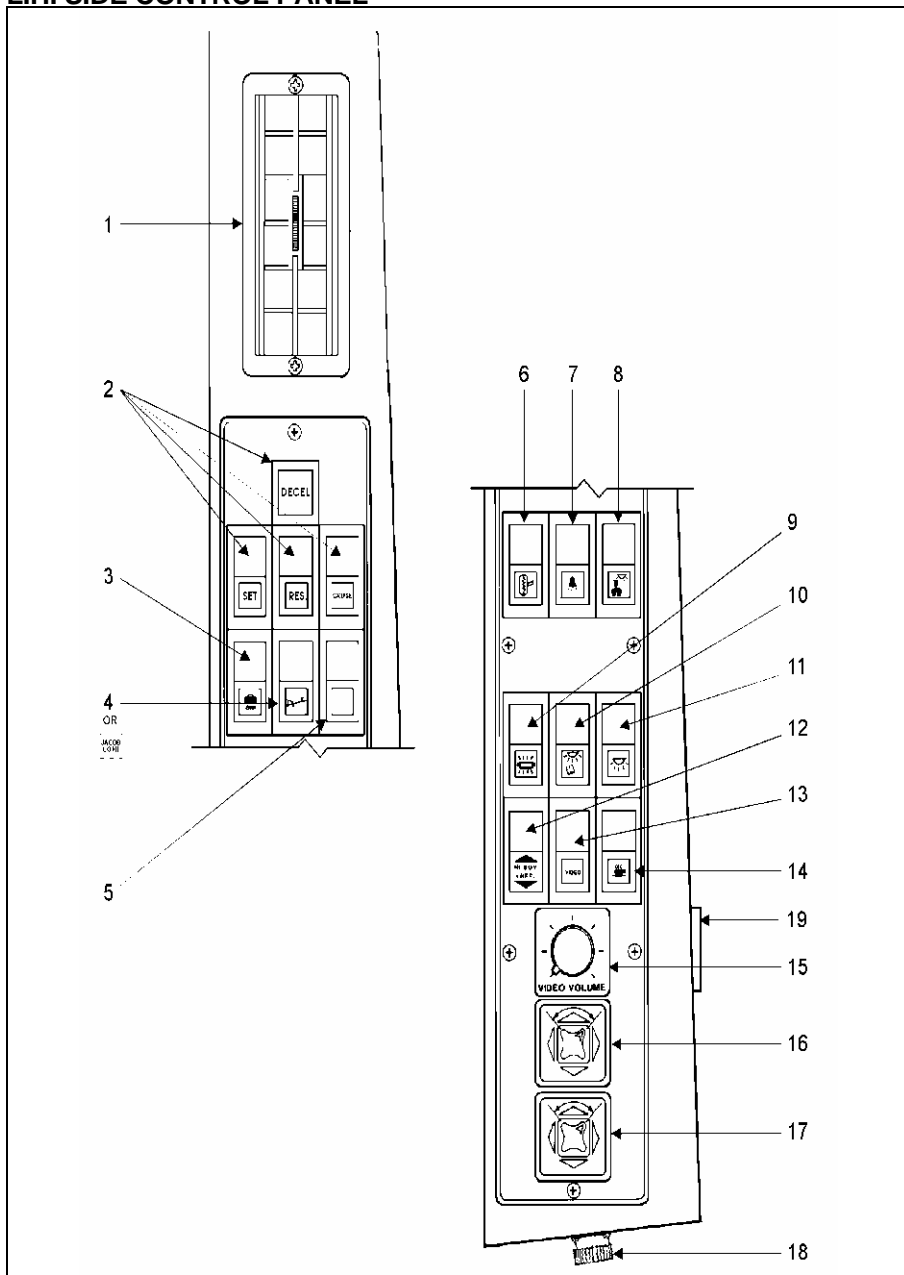

18108

1. Adjustable louver

The louver is manually adjustable, so the heated or cooled air flow can be directed towards driver or side window.

2. Cruise control switches (see page 2-6)

3. Baggage door lock (Optional)

Push up rocker switch to unlock the baggage doors and push down to lock. For additional information see page 2-35 under heading "*Baggage compartment*".

4. Transmission retarder (Optional) or **Engine retarder** (Optional) or **Blank**

Transmission retarder: Push down rocker switch to actuate transmission retarder. For system description, see page 4-5.

Engine retarder "Jacobs": Push down rocker switch to the first position to actuate system to half engine brake and press to the second position for a full application of engine brake. For system description, see page 4-4.

5. Blank for additional switch.

6. Exterior mirror heating switch

Push down rocker switch to operate the heating elements that clear frost, fog or thin ice from rear-view mirrors.

7. Stop/Service chime power switch

Push down rocker switch to power the chimes system which allows passenger operation of both the stop (disembarking) button and the service button. See page 2-41 for system description.

8. Driver's light switch (overhead lights)

Push down rocker switch to turn on the two (2) ceiling lights above driver. These lights are

frequently used for nighttime operation when passengers board or leave the coach.

9. Fluorescent lighting

Push down rocker switch to turn on the interior fluorescent lights, located under parcel racks. Use of these lights should be avoided when engine is not running.

10. Reading lamps

Reading lamps are controlled by two (2) different switches. Push down this rocker switch to energize the whole reading lamp circuit. Individual lamps can then be activated by each passenger using the switch incorporated in lamp body.

Reading lamps are mounted under parcel racks and can be focused to provide proper illumination for each passenger.

11. Dome lights

Push down rocker switch to turn on the aisle dome lights located on front of parcel racks.

12. Kneeling/Hi-Buoy control switch (Optional)

Kneeling: Momentarily push down rocker switch to lower the front end of coach 4" (100 mm), and up to return the coach to normal driving height. See page 3-3 for system description.

Hi-Buoy: Push up and hold rocker switch to raise the front end of the coach or both front and rear ends (depending on option) 4" (100 mm). Release the rocker switch to return the coach to the normal driving height. See page 3-3 for system description.

13. "VIDEO" system power switch (Optional)

Push down rocker switch to turn on TV monitors, TV converters and video cassette player.

NOTE: When both radio and video systems are on, speakers in the passenger area will be connected to the video system, while the speakers in the driver's area will be connected to the radio.

14. Galley power switch (Optional)

Push down rocker switch to energize the galley's electrical circuit.

15. Video volume (Optional)

Turn button clockwise to increase volume and counterclockwise to decrease.

16. L.H. outside mirror control (Optional)

Turn pointer knob to the left for mirror head adjustments and to the right for convex mirror adjustments, then push down on either of the button's four (4) sides to adjust the selected mirror's viewing angle.

NOTE: If the mirror assies on your vehicle do not include convex mirrors, only one (1) "Outside Mirror Control" will be installed for both mirrors (replacing items 16 & 17).

To operate, turn pointer knob to the left for L.H. mirror adjustments and to the right for R.H. mirror adjustments, then push down on either of the four (4) sides to adjust the selected mirror's viewing angle.

17. R.H. outside mirror control (Optional)

Turn pointer knob to the left for mirror head adjustments and to the right for convex mirror adjustments, then push down on either of the button's four (4) sides to adjust the selected mirror's viewing angle.

18. Diagnostic data reader connector

Datalink for DDEC 3, WT World Transmission and ABS brakes.

19. Microphone jack

Driver's P.A. system microphone jack (see page 2-39 for details).

CRUISE CONTROL SWITCHES

Introduction

The cruise control is an automatic speed control system that allows you to maintain a constant cruising speed above 20 m.p.h. (32 km/h) without depressing the accelerator pedal. The four (4) control switches are located on the L.H. side control panel (see page 2-5, item #2).

WARNING: Do not use the cruise control system when driving conditions do not permit maintaining a constant speed, such as in heavy traffic or on roads that are winding, icy, snow covered, slippery, or with a loose driving surface.

Setting vehicle speed

To turn on the system, push down "CRUISE" rocker switch, set the vehicle speed by accelerating to the desired speed, momentarily press and release the "SET" switch, and then remove your foot from accelerator pedal. This sets the cruising speed and stores it in memory, thus maintaining speed automatically.

NOTE: Cruise control system will not accept speed settings, nor will the "RESUME" switch operate, below approximately 20 m.p.h. (32 km/h).

Increasing set speed

Vehicle speed setting may be increased by one of the following methods:

1. Press and hold the "RESUME" switch until the desired speed is obtained. Releasing the "RESUME" switch will set the new higher speed.

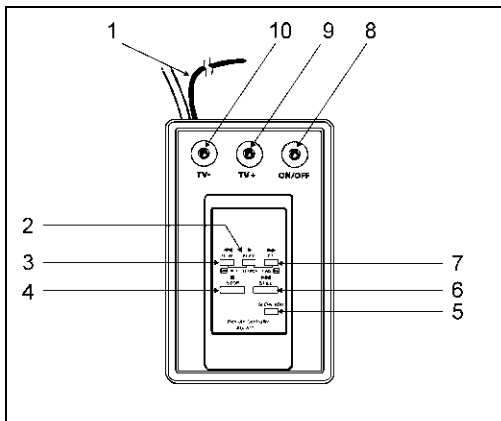

18110

NOTE: The system's volume control is located on L.H. side control panel (see item 15 on page 2-4).

NOTE: When using remote control, the front panel operation controls will not function, except for EJECT and STOP.

NOTE: Video operations (without remote control) are outlined in the manufacturer's instruction manual located in the video cassette player compartment.

1. M2 Jack

Insert into the "Remote" outlet on front of video as illustrated on page 2-7.

2. Play button

Press to play the video tape.

3. Rewind button (REW)

Press to rewind the video tape. When a tape is playing, press and hold to engage the reverse search mode.

4. Stop button

Press to stop video tape play.

5. Slow advance button

When this button is depressed during normal viewing, slow motion picture can be obtained.

If noises are audible while viewing a still picture press this button to mute.

6. Still button

Press to view a still picture. Press again to return to regular play.

7. Fast-forward button (FF)

Press to fast-forward the video tape. Press and hold to engage the forward search mode.

NOTE: Items 8,9 & 10 are only available with TV Receiver Antenna Option.

8. TV converter button (ON/OFF)

Press to turn on TV converter; press again to turn off. When the TV converter is turned off, the video cassette player is selected automatically.

9. Channel up button (TV+)

Press and release to select next higher channel. Press and hold to scan upwards.

10. Channel down button (TV-)

Press and release to select next lower channel. Press and hold to scan downwards.

Mute

Press (for 3 seconds) and release "TV+" and "TV-" simultaneously to turn "OFF" sound. Repeat to turn sound "ON".

Dashboard (without Tachograph)

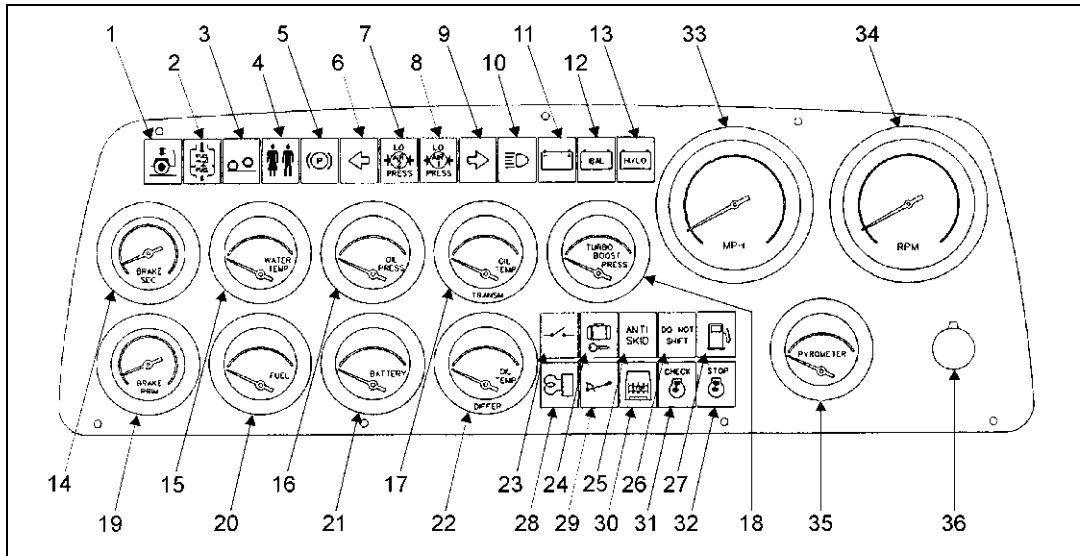

18113

- | | |
|---|--|
| <p>01.....Kneeling/Hi-buoy, or Low Buoy, or High Buoy (All Optional), or Blank</p> <p>02..... Water separator (Optional), or Blank</p> <p>03..... Tag axle unloading, or Retractable tag axle (Optional)</p> <p>04..... Lavatory door lock</p> <p>05..... Parking brake</p> <p>06.....L.H. turn signal - Hazard</p> <p>07..... Low secondary air pressure</p> <p>08..... Low primary air pressure</p> <p>09..... R.H. turn signal - Hazard</p> <p>10.....High beams</p> <p>11..... Battery</p> <p>12..... Battery balance</p> <p>13..... High or low battery voltage</p> <p>14..... Secondary air pressure gauge</p> <p>15..... Engine coolant temperature gauge</p> <p>16..... Engine oil pressure gauge</p> <p>17..... Transmission oil temperature gauge (Optional), or Blank</p> <p>18..... Turbo boost pressure gauge (Optional), or Blank</p> <p>19..... Primary air pressure gauge</p> <p>20..... Fuel gauge</p> | <p>21..... Voltmeter</p> <p>22.....Differential oil temperature gauge (Optional), or Blank</p> <p>23.....Electrical systems (XL-45 only), or Blank</p> <p>24..... Baggage compartment door lock (Optional), or Blank</p> <p>25..... Antilock braking system (Optional), or Blank</p> <p>26..... Transmission "DO NOT SHIFT" light</p> <p>27..... Low fuel level (Optional), or Blank</p> <p>28..... Preheating system (Optional), or Blank</p> <p>29..... Output retarder (Optional), or Blank</p> <p>30..... Brake light</p> <p>31..... Check engine</p> <p>32..... Stop engine</p> <p>33..... Speedometer-Odometer</p> <p>34..... Tachometer</p> <p>35..... Pyrometer gauge (Optional), or Blank</p> <p>36..... Instrument and switch brightness control</p> |
|---|--|

Dashboard (with Tachograph)

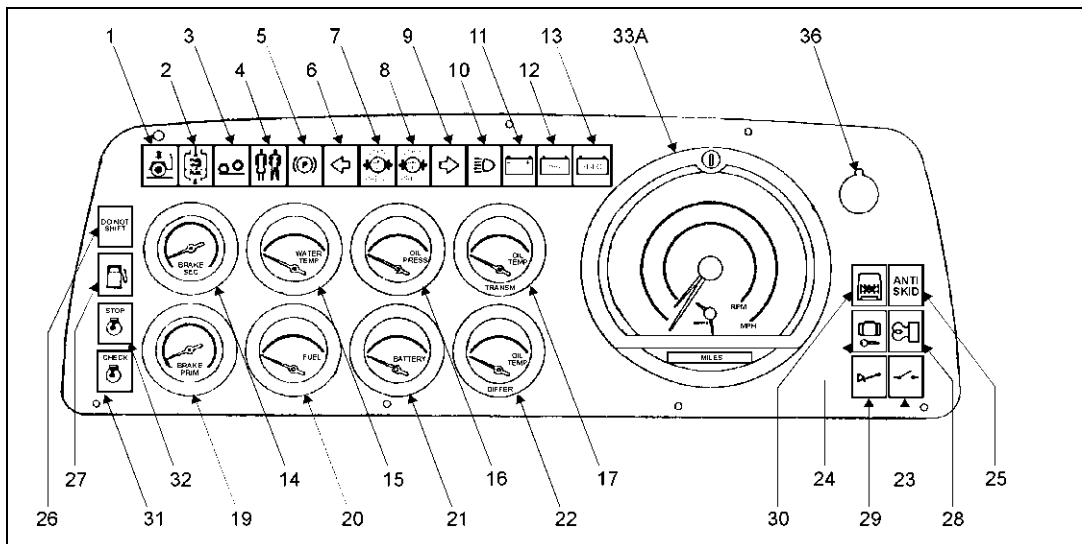

18112

- | | |
|---|--|
| <p>01.....Kneeling/Hi-buoy, or Low Buoy, or High Buoy (All Optional), or Blank</p> <p>02..... Water separator (Optional), or Blank</p> <p>03..... Tag axle unloading, or Retractable tag axle (Optional)</p> <p>04..... Lavatory door lock</p> <p>05..... Parking brake</p> <p>06..... L.H. turn signal - Hazard</p> <p>07..... Low secondary air pressure</p> <p>08..... Low primary air pressure</p> <p>09..... R.H. turn signal - Hazard</p> <p>10..... High beams</p> <p>11..... Battery</p> <p>12..... Battery balance</p> <p>13..... High or low battery voltage</p> <p>14..... Secondary air pressure gauge</p> <p>15..... Engine coolant temperature gauge</p> <p>16..... Engine oil pressure gauge</p> <p>17..... Transmission oil temperature gauge (Optional), or Blank</p> <p>18..... Turbo boost pressure gauge (Optional), or Blank</p> <p>19..... Primary air pressure gauge</p> | <p>20..... Fuel gauge</p> <p>21..... Voltmeter</p> <p>22..... Differential oil temperature gauge (Optional), or Blank</p> <p>23..... Electrical systems (XL-45 only), or Blank</p> <p>24..... Baggage compartment door lock (Optional), or Blank</p> <p>25..... Antilock braking system (Optional), or Blank</p> <p>26..... Transmission "DO NOT SHIFT" light</p> <p>27..... Low fuel level (Optional), or Blank</p> <p>28..... Preheating system (Optional), or Blank</p> <p>29..... Output retarder (Optional), or Blank</p> <p>30..... Brake light</p> <p>31..... Check engine</p> <p>32..... Stop engine</p> <p>33A..... Tachograph (Optional)</p> <p>36..... Instrument and switch brightness control</p> |
|---|--|

Dashboard indicator/warning lights and instruments**1. Kneeling/Hi-buoy (Optional), or Low Buoy (Optional), or High Buoy (Optional)**

Lights when either of the three (3) Optional Suspension Systems is operating. See page 2-5 for Kneeling/Hi-buoy and High Buoy system descriptions and page 2-20 for Low Buoy.

2. Water separator (Optional)

Lights when the accumulated water in the diesel fuel filter/water separator should be drained (see page 6-8).

3. Tag axle unloading (Standard), or Retractable tag axle (Optional)

Depending on which system was installed on your coach, the indicator light will illuminate when the tag axle is unloaded or retracted. Furthermore, an alarm will sound, telling the driver that the axle is unloaded/retracted. See page 2-20 & 4-21 for both system descriptions.

4. Lavatory door lock

Illuminates when the lavatory door is locked.

5. Parking brake

Lights when parking brake is applied (see page 2-20).

6. L.H. turn signal - Hazard

Flashes when L.H. turn signal is selected with multifunction lever or when hazard switch is turned on. (When hazard switch is turned on both L.H. and R.H. turn signals will flash.)

7. Low secondary air pressure

Lights when air pressure in secondary system is too low. For System information, see "BRAKES" on page 3-1.

8. Low primary air pressure

Lights when air pressure in primary system is too low. For System information, see "BRAKES" on page 3-1.

9. R.H. turn signal - Hazard

Flashes when R.H. turn signal is selected with multifunction lever or when hazard switch is turned on. (When hazard switch is turned on both L.H. and R.H. turn signals will flash.)

10. High beams

Lights when headlight high beams are selected (see page 2-16 item #3).

11. Battery

Lights when alternator is not functioning properly.

12. Battery balance

Lights when batteries are out of balance.

NOTE: Before seeking assistance, check that the demand for the 12 volt power is not exceeding rated amperage output of battery equalizer(s), and also check circuit breaker on battery equalizer(s) (for location, see page 4-18). Allow at least 15 minutes to balance batteries after corrective measures have been taken.

13. High or low battery voltage

Lights when battery voltage exceeds 30 volts or drops below 24 volts.

14. Secondary air pressure gauge (Brakes)

Indicates air pressure in the secondary system. Normal reading varies from 95 to 125 psi (655 to 860 Kpa).

15. Engine coolant temperature gauge

Indicates engine coolant temperature. Normal reading should vary from 190 to 215°F (88 to 102° C).

In extremely hot weather and high altitude, the coolant temperature can reach 215°F (102°C) and more when climbing a long grade at full throttle. If this situation occurs, the "check engine" light will come on (at 217°F - 103°C) and the engine overtemperature protection system (EOP) will be activated. If the cooling system is properly maintained, the temperature should stabilize below the shut back temperature of 222°F (106°C) so the vehicle can operate normally. See also item # 31 on page 2-13.

NOTE: Engine is not considered "overheating" when below 215°F (102°C).

16. Oil pressure gauge

Indicates engine oil pressure. Normal reading at operating temperature should vary from 50 to 70 psi (345 to 483 Kpa) at cruising speed.

17. Transmission oil temperature gauge (Optional)

Indicates transmission oil temperature. Normal reading can vary from 160 to 250°F (70 to 120°C).

NOTE: On vehicles equipped with a transmission retarder, the temperature may rise to a maximum of 330°F (165°C) if operated for extended periods.

18. Turbo boost pressure gauge (Optional)

Indicates turbo boost pressure in psi. Reading depends on engine rpm and load conditions. It is normal that pressure reaches the gauge's maximum level.

NOTE: If item #22 is not a chosen option on your vehicle, then "Turbo boost pressure gauge" will be located in its position at #22.

19. Primary air pressure gauge (Brakes)

Indicates air pressure in the primary system. Normal reading varies from 95 to 125 psi (655 to 860 Kpa).

20. Fuel gauge

Indicates the amount of fuel remaining in the fuel tank. If your vehicle has an optional auxiliary tank, the gauge will show the total fuel level, as the tanks are interconnected.

CAUTION: Operating the vehicle when the reading is below 1/8 full is not recommended.

21. Voltmeter

Indicates electrical system voltage. With engine operating, normal reading should be 27.5 volts.

22. Differential oil temperature gauge (Optional)

Indicates differential oil temperature. Normal reading should not exceed 250°F (120°C).

NOTE: If "Differential oil temperature gauge" is not a chosen option on your vehicle, then "Turbo boost pressure gauge" (normally item #18) will be located in this position if it is a selected option.

23. Electrical systems indicator (Optional) (XL-45), Dummy (XL-40)

Illuminates if the battery master switch (located on L.H. Lower Control Panel - see page 2-15) is left "ON" when ignition switch is turned "OFF".

24. Baggage compartment door lock indicator (Optional)

Will light if any one or several of the baggage compartment doors are unlocked.

25. Antilock braking system (Optional)

Lights until vehicle speed reaches 4mph (7 km/h), and when the antilock braking system is malfunctioning.

26. Transmission "DO NOT SHIFT" light

See page 4-6 for description.

27. Low fuel level (Optional)

Lights when approximately 12 U.S. gallons (45 liters) of fuel remains in the tank(*). It is recommended that you do not exceed a distance

of 75 miles (120 km) after light has turned on. Light will illuminate "ON" & "OFF" just before running out of fuel. Fill tank as soon as possible.

(*) - Applies to 160 U.S. gallon tank. For other optional tank volumes and distances see below:

- 250 U.S. gallons (160 + 90) = 15 U.S. gallons (57 liters), 90 miles (150 km).
- 208 U.S. gallons = 17 U.S. gallons (64 liters), 100 miles (165 km).
- 298 U.S. gallons (208 + 90) = 21 U.S. gallons (80 liters), 126 miles (210 km).

28. Preheating system (Optional)

Lights when preheating system is turned on. For systems description, see pages 2-43 & 2-44.

29. Output retarder (Optional)

Lights when transmission's output retarder is activated. For system description, see page 4-5.

30. Brake light

Lights when brakes are activated.

31. Check engine

Will light if a minor engine malfunction is detected by the DDEC (Detroit Diesel Electronic Control) system. This includes any situation where the engine coolant reaches 217°F (103°C) because of cooling system problems or because of situations described on page 2-11 (item # 15). This light will remain illuminated until malfunction is corrected. Furthermore, this indicator flashes to indicate engine malfunction codes when the required procedure outlined on page 5-7 has been performed.

NOTE: As a light bulb and systems check, this indicator will illuminate when the ignition switch is turned "ON". After about five seconds the light will turn off.

32. Stop engine

Will light when major engine problems occur. The engine power will automatically begin to decrease gradually and will be followed by an automatic shutdown after 30 seconds. This 30 second delay period may be repeated using the "Stop Engine Override Switch" outlined further on page 2-15 (item #5).

NOTE: Once engine is stopped, it cannot be restarted until malfunction is corrected.

As a light bulb and systems check, this indicator will illuminate when the ignition switch is turned "ON". After about five seconds the light will turn off.

33. Speedometer-odometer

The speedometer indicates the vehicle speed. The odometer indicates the distance driven;

U.S. vehicles: Miles/Kilometers (Miles predominant)
Canadian vehicles: Kilometers/Miles (Kilometers predominant)

33A. Tachograph (Optional)

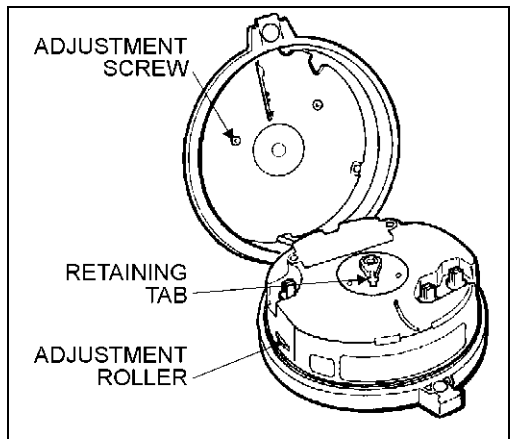

18115

CAUTION: *The Tachograph is factory programmed. Do not change dip-switch positions.*

Speedometer

Indicates coach speed in miles per hour (mph - US models) or kilometres per hour (km/h - Can. models).

The speed-warning light, located in the lower section of the dial, is set by the adjusting screw located in the left half of the tachograph body. The speed at which the warning occurs is displayed in a small window.

Odometer

The odometer registers the distance travelled either in miles (US models) or kilometres (Can. models).

Tachometer

Indicates the operating speed of the engine in hundreds of revolutions per minute (RPM x 100). The tachometer serves as a guide for gear shifting, and helps prevent engine overspeeding when going downhill with the Jacobs engine brake operating. The maximum allowable engine speed is 2,450 rpm.

Clock

The clock operates continuously, even if the main battery disconnect switches are set to the OFF position. To set the clock, open the tachograph cover using the key provided, and set the time using the thumb wheel on the L.H. side of the tachograph.

Diagram Chart

The diagram chart recording speedometer and tachometer data covers a 24-hour period. Open the tachograph cover using the key provided, then insert the diagram chart with the MPH or KM/H side facing up. Make sure the chart is

correctly positioned on the drive boss before closing the cover.

CAUTION: *To prevent damage to the mechanism, do not run the engine with a damaged diagram chart or without a diagram chart. Install a dummy plastic card (Prévost part no. 590251) if the coach is operated without a diagram chart.*

34. Tachometer

Indicates engine speed in hundreds of revolutions per minute (rpm) and serves as a guide for proper gear shifting. It also helps the driver in preventing excessive engine speeds when going down steep grades, with engine serving as a brake. Maximum allowable engine rpm is 2450.

35. Pyrometer gauge (Optional)

Indicates exhaust manifold temperature in hundreds of °F. Normal reading should vary between 500 and 1100 °F according to operating conditions. Temperature should not exceed 1100° F.

36. Instrument & switch brightness control

Adjust as required. Brightness is progressively dimmed as control knob is rotated clockwise.

NOTE: *Dashboard panel gauges show approximate readings and should not be relied upon for mechanical adjustments.*

L.H. lower switch panel

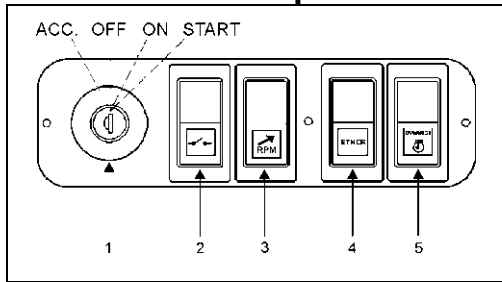

18116

Switches

1. Ignition

Ignition switch has four (4) positions:

"ACCESSORIES": Turn key counterclockwise; only the vehicle accessories are operational and key cannot be removed.

"OFF": Ignition is "OFF" and key can be removed.

"ON": Ignition is "ON" and key cannot be removed.

"START": Starting position; spring-loaded ignition switch returns to "ON" position after starting. Ignition key must be returned to "OFF" position before trying to restart.

WARNING: Do not engage starter for more than 15 seconds. Allow starter time to cool before engaging again. This will prevent starter from overheating and will allow the time delay relay to cool.

2. XL-40: Blank for additional switch.

2. XL-45: Battery master switch

Both the 12 volt and the 24 volt systems are activated by the master switch. The indicator light (located on dashboard - see page 2-9, item #23) will illuminate if switch is left "ON" when ignition switch is turned "OFF".

CAUTION: When vehicle is parked overnight or for an extended period of time, battery master switch should be set to the "OFF" position.

NOTE: When battery master switch is set to the "OFF" position, the electrical supply from the batteries is cut off, with the exception of the Fire Detection System, the Engine & Transmission Electronic Controls, the Auxiliary Heating System, the Battery Equalizers and the Tachograph power supply.

3. Fast idle

Push down rocker switch to engage fast idle, thus increasing engine speed to approximately 1100 rpm. Use this switch for extended stops.

NOTE: If parking brake is released and/or transmission is shifted with the engine running at fast idle, engine will reduce its speed to idle and maintain this rpm as long as parking brake is not applied and/or transmission is in the neutral position. If engine is stopped with the fast idle switch in the "ON" position, this control will automatically be cancelled when restarting the engine; the driver must then shut off, and reset rocker switch to reactuate fast idle. Generally, fast idle should be reduced to low idle before shutting off engine.

4. Ether cold starting aid (Optional) or Blank

Activates ether cold starting device in engine compartment (see "Cold weather starting" page 4-8).

5. "Stop Engine" override

Push down rocker switch to reset the 30 second delay period and the shutdown procedure. This switch can be repeatedly depressed, i.e. **one (1) pulse is sufficient for each 30 second period**, for engine power in an emergency situation.

NOTE: The stop engine override switch will be operative only if it has been depressed before the end of the 30 second delay period.

CAUTION: The "Stop Engine" override must be used only in emergency situations to bring vehicle to a safe stop. Excessive use of this switch could cause serious damage to the engine.

R.H. lower switch panel

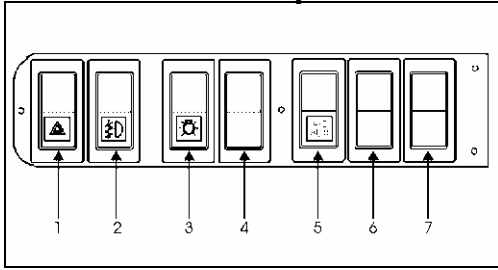

18021B

Switches

1. Hazard flashers

Push down rocker switch and all turn signal lights will flash simultaneously. Turn signal indicator lights in dashboard will also flash.

2. Fog lights (Optional) or Blank

Push down rocker switch to activate fog lights as well as clearance, tail and marker lights. Before using fog lights, remove protective covers by pulling on their edges.

WARNING: Before removing protective covers, stop engine and apply parking brake.

3. Exterior lighting switch

Push down rocker switch to the first position to activate clearance, tail & marker lights and to the second position for headlights.

NOTE: Daytime running lights will be automatically cancelled when this switch is pushed to second position. For system information, refer to section "Safety" under heading "Day time running lights" on page 3-5.

4. Blank for additional switch

5. Auxiliary A/C (Optional) or Blank

Push down rocker switch to activate auxiliary A/C system (see page 4-13, item #9).

6. Blank for additional switch

7. Blank for additional switch

R.H. console

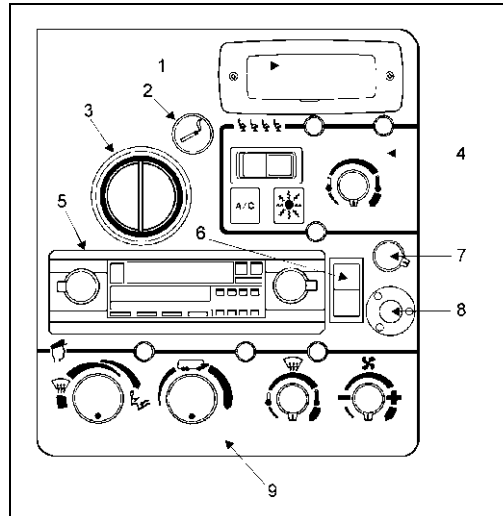

18111

1. Ashtray (Optional)

To open, push in on left side. Remove ashtray by pressing on inner tab.

2. Cigarette lighter (12 volts) (Optional)

Push in to activate; lighter will pop out when ready for use. Return lighter to initial (non-activated) position. The lighter socket can also be used for 12 volt appliances with a maximum consumption of 130 watts (10 amps), such as a flashlight or small vacuum cleaner. Do not use appliances equipped with unsuitable plugs as they may damage socket and/or electrical circuit.

NOTE: Lighter and socket remain functional even when ignition is "OFF".

3. Adjustable louver

The louver is manually adjustable, so the heated or cooled air flow can be directed as desired.

NOTE: An additional adjustable louver is located on L.H. side control panel to defrost window. A third adjustable louver is located at extreme right of dashboard and can be used to concentrate warm air on windshield area used to view exterior R.H. side mirror.

4. Central A/C-heating system controls (Optional)

These controls are used to obtain desired temperature inside vehicle. For system description see page 4-11.

5. AM/FM stereo cassette receiver with CD changer remote

Instructions for proper utilization of the sound system are included in the technical publications package supplied with the coach.

NOTE: When video switch is activated, the passenger area speakers are automatically switched from radio to video.

6. Speaker selector switch (Optional)

Push up rocker switch to operate the speakers in driver's area only. Push down rocker switch to operate the speakers in the passenger area only. Place the rocker switch in the central position to operate the speakers in both areas.

7. PA system volume control

Turn clockwise to increase PA system volume control.

8. Microphone jack

Plug in PA system microphone in this outlet to address passengers; with or without background music, depending on radio option.

9. Driver's A/C - heating system controls

These controls are used to obtain desired temperature in driver's area. For system description see page 4-12.

Engine data display & computer - ProDriver™

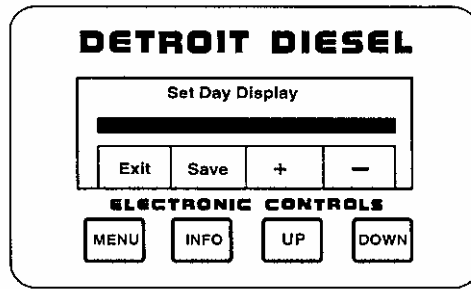

18034

ProDriver™ is a graphic device that displays and records operational data transmitted by the Detroit Diesel Electronic Controls (DDEC) on the diagnostic data link. It utilizes a vacuum fluorescent (VF) display for wide viewing angles and excellent visibility in all ambient light conditions.

ProDriver™ has many driver friendly features designed to provide instantaneous feedback to the driver. This allows him to understand the effect of his actions on engine and vehicle performance. There are two (2) display screens automatically shown, which offer real time feedback based on the vehicle activity. Should an alert message be sent out by the ECM, the driver will be shown what is wrong and how the engine power will change.

Data available from ProDriver™ includes:

- Instantaneous and average fuel economy
- Trip time, miles, fuel used, fuel economy, average speed
- Driving time, percentage, miles, fuel used, fuel economy
- Idle time, fuel and percentage
- Cruise time, percentage, miles, fuel used, fuel economy

- Top gear time, percentage, miles, fuel used, fuel economy
- VSG (previously PTO) time, fuel used, and percentage
- Overspeed time and percentage for two (2) speed thresholds
- Over-rev time and percentage
- Maximum vehicle speed and RPM
- Coasting time and percentage
- Automated oil change interval tracking
- Hard braking incident records
- Driver initiated incident records, and
- Stop and check engine code logs.

NOTE: Refer to *Detroit Diesel ProDriver[™] Operating Manual (6SE701)*, for a full description of how to set up and operate your ProDriver[™] display.

Button functions

- "MENU" - Displays main menu or previous menu level.
- "INFO" - Displays selected menu options; saves new data.
- "UP" / "DOWN" - Move selection arrow up or down, or move from screen to screen when multiple screens are available.

Button combinations

Press "UP" and "DOWN" at the same time to store an incident record.

Special button functions

Alternate labels are displayed along the bottom of the screen directly over each button when the buttons are used to perform special functions.

DISPLAY SCREENS**Idle time**

Automatically displayed when engine is idling. Shows idle time for current leg of the trip and as a percentage of engine running time. A bar graph shows the idle percentage compared to the fleet goal.

Fuel economy

Automatically displayed when the vehicle is moving. Shows average fuel economy for current leg of the trip digitally and as a bar graph, with the fleet goal centered on the screen. Instantaneous economy is shown as a series of arrows. UP arrows show an improving leg average, while DOWN arrows show a decrease. The number of arrows shows the amount of change.

Warning screens

Speeding, over revving, excessive idling and oil change screens will be displayed until acknowledged by pressing any button or the condition ceases. The display will return to the screen previously shown.

Alert screens

Shown if a warning condition exists with the engine. Will be displayed until acknowledged by pressing any button.

NOTE: Menu displays are available only when the vehicle is stationary. The display may be viewed with the ignition OFF by pressing "MENU".

To edit the main menu at idle:

IDLE SCREEN, "MENU" = MAIN MENU, "MENU" = IDLE SCREEN.

To review leg summary information at idle:

IDLE SCREEN, "INFO" = SUMMARY 1, "INFO" = SUMMARY 2, "INFO" = IDLE SCREEN.

To review trip summary information at idle:

IDLE SCREEN, "MENU", → TRIP SUMMARY, "INFO" = view trip summary page 1, "INFO" or "DOWN" = view trip summary page 2. Continue to press "INFO" or "DOWN" to view all the trip summary pages. "MENU" = Main menu, or "MENU", "MENU" = idle screen.

To review leg summary info while in motion:

ECONOMY SCREEN, "INFO" = SUMMARY 1, "INFO" = SUMMARY 2, "INFO" = ECONOMY SCREEN.

Display brightness

Temporary adjustments may be made while in the fuel economy, idle or leg summary screens by pressing "UP" or "DOWN". The normal setting returns the next time the engine is started.

Entering driver ID

From the main menu screen, → Configuration "INFO", → Driver ID "INFO". Press "UP" to increment the selected digit. Press "DOWN" to select the next digit to the right. Press "INFO" to save the completed entry or press "MENU" to exit without saving changes.

R.H. LATERAL CONSOLE

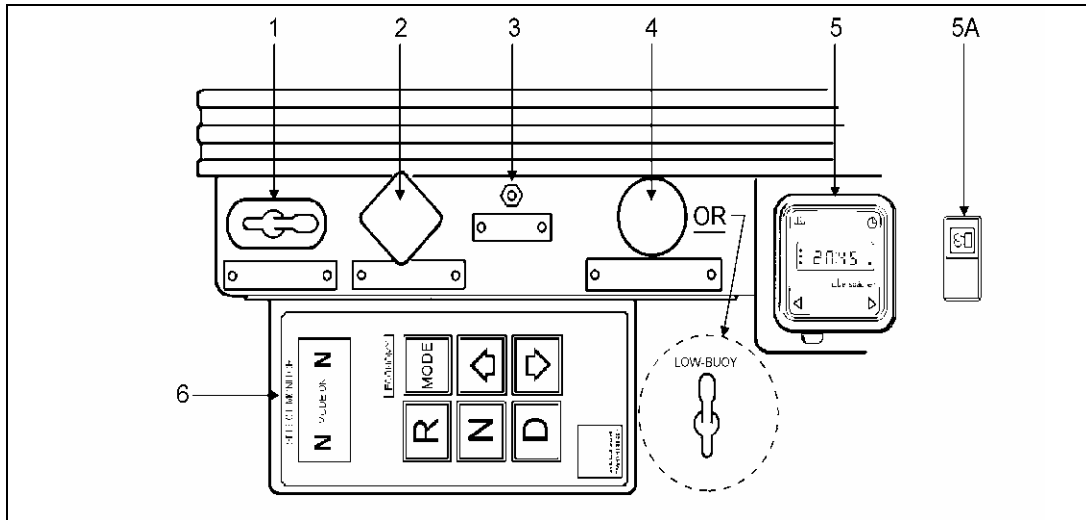

18117

1. Tag axle unloaded or retractable

Vehicle can be fitted with either the standard tag axle unloaded system or the optional retractable tag axle system. When valve is switched to the "Wheels up" position, the tag axle air springs are unloaded (depleted) with the tag axle unloaded system or, tag axle is raised with the retractable tag axle system. For both systems' descriptions, see page 4-21.

brakes will automatically be applied at full capacity on drive axle to stop vehicle. Cause of pressure loss should be determined and corrected before proceeding. However, vehicle may also be equipped with an optional parking brake release system (Parking brake override) which will allow driving the vehicle for a short period of time to a safe parking area. To operate, push and hold down the control knob with vehicle in motion.

2. Parking brake control

See "Combination emergency and parking brakes" on page 2-25.

Low-Buoy: Low-buoy option is used to lower the coach by approximately 4 inches (100 mm) when valve is positioned towards "LOW-BUOY". For system description, see page 3-3.

3. Door override

In the event of a malfunction in the front entrance door air lock mechanism, press this button to release air lock (see page 3-4).

5. Auxiliary Preheating System Timer (Optional) (ESPAR (shown) OR WEBASTO)

See pages 2-43 & 44 for description of both heaters.

4. Parking brake override (Optional) or Low-Buoy (Optional)

Parking brake override: If during normal operation, primary system air pressure drops below 40 psi (276 kPa), spring-loaded parking

5A. Preheater switch (Opt. with item #5)

Push down rocker switch to turn "ON" Preheating system; supplementing Central Heating System when required. Preheater will turn "ON" and

"OFF" automatically depending on coolant temperature.

6. Transmission push-button shifter

Use shifter to select forward, neutral or reverse gears of transmission. "AUTOMATIC TRANSMISSION" system operations are described on next page.

AUTOMATIC TRANSMISSION

The operation and driving of this vehicle with an automatic transmission is similar to that of an automobile equipped with an automatic transmission. Proper ranges should be selected according to driving speeds to improve vehicle performance and control. The transmission is fully automatic. Speed ratio of power converter changes automatically as vehicle speed increases and direct-drive goes in and out as necessary, modulated by vehicle speed, and accelerator position.

Range selection - Push-button shifter

The push-button shifter is used by the operator to select Neutral (N), Reverse gear (R), or a range of forward gears. When a forward gear range has been selected, the transmission starts in the lowest gear of the range and, as conditions permit, automatically upshifts until the highest gear in the selected range is in use.

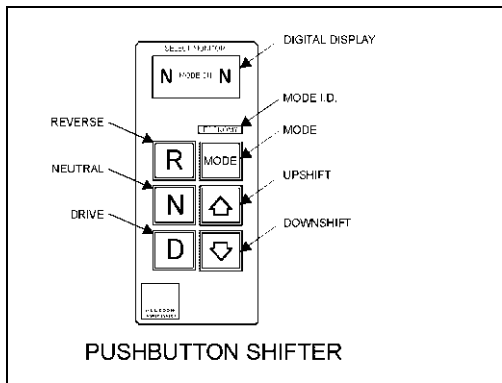

18015

The digital display indicates the readout of two (2) digits:

SELECT - Range of gears selected by the operator.

MONITOR - Current gear of transmission operation.

Each time a button is pressed on the shifter a short "beep" will be heard to identify that the ECU has received instructions to change operation. The function of each button is as follows:
Select **REVERSE** gear by pressing "R".

Select **NEUTRAL** by pressing "N". Note the raised edge around the "N" button so the driver can orient his hand to the push-buttons by touch, without looking at the display. It is not necessary to press this button prior to starting the vehicle.

Select **DRIVE** range by pressing "D". The highest forward gear will appear on the *SELECT* display and the transmission will shift to the starting gear as indicated on the *MONITOR* display.

The *UPSHIFT* and *DOWNSHIFT* (arrow) buttons are used to shift to a higher (if not in "D") or lower (if not in "1") range selected. One press changes the range selected by one range. If the button is pressed continuously, the range selected continues to change up or down until the button is released or until the highest or lowest possible range of gears is selected.

Function of the mode button

This button is used to invoke a special function that has been programmed into the ECU. This function is the "ECONOMY" mode which allows for more efficient operation of the transmission and thereby helps contribute to improved fuel economy. The mode status will be indicated on the digital display by lighting *MODE ON* when the function has been selected.

Shift schedule

PRIMARY - This shift schedule is used each time the vehicle is started. Typically, this is used for normal vehicle operation.

SECONDARY - This is an alternate shift schedule that the ECU may use upon request.

Select the secondary shift schedule (*ECONOMY*) via the **MODE** button.

HOLD UPSHIFT - This shift schedule permits upshifts if an overspeed condition could occur by the transmission remaining in a lower range. These shifts occur at speeds higher than normal upshifts.

In most cases the control system logic protects the transmission from abuse. Such actions as full throttle neutral-to-range shifts and high speed direction changes are inhibited.

Operation

When a push-button pad is depressed, a beep sounds and the pad lights up indicating the transmission is ready to operate in the selected range. When the electronic control system detects a serious problem in the transmission, a buzzing tone sounds for 5 seconds, and the "**DO NOT SHIFT**" light on the dashboard (item #26 on page 2-9 & 2-10) illuminates to warn the driver that the transmission is held-in-gear. If another pad is depressed, the buzzing sound will continue until the original range is selected.

NOTE: As a light bulb and systems check, the "**DO NOT SHIFT**" light will illuminate when the ignition switch is turned "ON". After about two seconds the light will turn off. If the "**DO NOT SHIFT**" light remains on, the self-diagnostic system has detected a problem. If the problem disappears, the light will go out, but a trouble code will remain stored in the ECU.

A) Reverse (R)

Use this position to back up vehicle. Stop completely before shifting from forward to reverse or from reverse to forward. Touch the reverse (R) pad, the pad will light up and the reverse warning signal will be activated.

B) Neutral (N)

Use this position to start engine. Select neutral (N) when checking vehicle accessories, and for extended periods of engine idle operation; parking brake must then be applied. The pushbutton shifter will automatically select neutral when the master switch is turned on.

CAUTION: Detroit Diesel engines should not be idled for extended periods at "low" idle. For extended idling, engine should run at "fast" idle.

WARNING: Always apply parking brake before leaving driver's seat.

Do not allow your vehicle to "coast" in Neutral. This practice can result in transmission damage. Also, no engine braking is available in Neutral.

C) Drive (D)

Use this position for all normal driving conditions. After touching this pad, the vehicle will start in first or second range and will automatically upshift to a higher range as output speed increases. As the vehicle slows down, output speed decreases, and the transmission automatically downshifts to the correct range. If a locked brake or a slick surface condition should occur, the ECU (Electronic Control Unit) will command converter operation (disconnect lockup) and inhibit downshifts for a period of time or until normal wheel speed has been restored.

NOTE: The transmission should normally be allowed to shift itself, but manual shifting can be used as described below.

D) Fourth (4) and Third (3) ranges

Select these ranges when driving on moderate grades, or when load and traffic conditions require the use of limited speed.

E) Second (2) range

Select this range when operating in heavy and congested traffic. The transmission will start in first and automatically upshift to second. When slowing, the transmission will automatically downshift to first range. Low ranges provide progressively greater engine(*) and retarder(*) braking power (the lower the range, the greater the engine(*) and retarder(*) braking effect).

F) First (1) range

Select this range when pulling through mud and snow, or when speed control is needed for driving up steep grades. This range also provides maximum engine(*) braking power or retarder(*) braking effect. In the lower ranges (1, 2, 3, and 4), transmission will not upshift above the highest

gear selected unless recommended engine governed speed for that gear is exceeded.

CAUTION: Service brakes (foot pedal) should not be used to control the speed of vehicle on long, steep descents. Instead, lower transmission ranges should be used (in conjunction with output retarder(*)). When descending in lower ranges, care must be taken that engine speed does not exceed 2450 rpm. This procedure keeps service brakes cool and ready for emergency stopping.

- (*) - Refers to "JACOBS engine brake" and "Transmission output retarder" options. See pages 4-4 & 4-5 for details regarding both systems.

**MANUAL TRANSMISSION
6 OR 7-SPEED**

The manual transmission has 6 or 7 forward speeds (including creeper) and one reverse.

NOTE: A Spicer PS145-7A, 7-speed transmission, is specified with the 12.7 liter, series-60, 400-horsepower engine and a PS130-6B, 6-speed, is specified with the optional 11.1 liter, 325-horsepower engine.

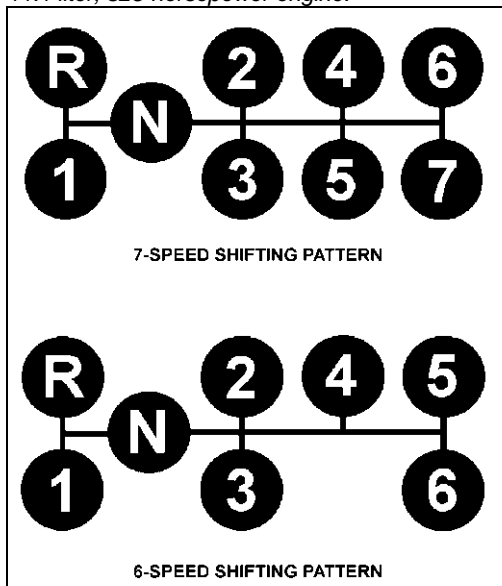

07008

The transmission shift lever located to the right of the driver's seat is used to select gears. The coach is equipped with a safety switch to prevent accidental starter engagement if the shift lever is not in the neutral position.

When shifting from neutral to first or reverse gear, depress the clutch pedal fully to activate the clutch brake. This makes it easier to shift from neutral to forward or reverse.

CAUTION: To avoid damaging the clutch brake mechanism, do not fully depress the clutch pedal when the coach is in motion.

Upshifting

Always start moving the coach forward with the transmission in first gear, then shift to second, third, fourth, fifth, sixth and seventh gears (if applicable). Do not skip gears. Do not shift to the next higher gear until the engine speed has reached 1,900 rpm. Double clutching is recommended for shifting gears.

Downshifting

Double-clutching is also recommended for downshifting. Always change to a lower gear to avoid engine lugging. Use lower gears when driving uphill or downhill, and when driving on ice, snow or mud (minimum 1,400 rpm).

Use lower gears when driving downhill to make full use of engine compression. Never let the engine operate above 2,450 rpm.

Under normal driving conditions, it is not always necessary to downshift through all gears. Downshift from seventh to first gear after bringing the coach to a complete stop.

CAUTION: Never let the engine operate above 2,450 rpm.

CAUTION: Always leave the shift selector in neutral when the coach is parked.

CAUTION: To prevent premature clutch wear, always start driving the coach with the transmission in first gear.

CAUTION: Before ascending or descending a long or steep grade, reduce speed and shift to a lower gear. Use lower gears to control speed and avoid prolonged or frequent braking which will result in brake overheating and reduce brake effectiveness. To reduce brake wear, use the Engine Retarder System "JACOB" when descending a steep grade.

WARNING: Shifting to lower gears on slippery surfaces should be done with caution. Sudden engine compression braking could cause drive wheels to lock-up, and may result in loss of control.

STEERING COLUMN CONTROLS

Multifunction lever

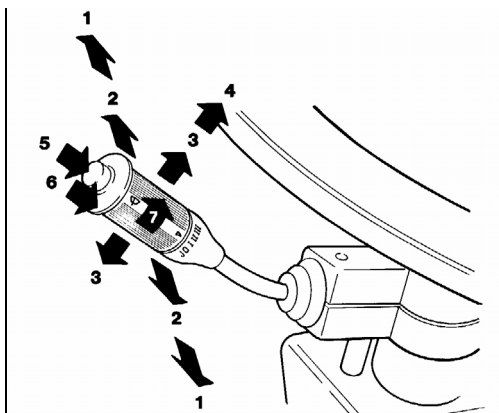

18024

Use the "Multifunction lever" to operate the following accessories:

1. Turn signal

Move the lever up to upper position 1 to signal a right-hand turn, and down to lower position 1 to signal a left-hand turn. When the turn is completed, the signal will be cancelled and lever will automatically return to its initial position.

2. Lane change signal

Move the lever up or down, part way to either positions 1, and hold it there. The lever will return to its initial position when released.

3. Headlight beam changer

High beams or low beams can be selected by respectively pushing the lever towards the dashboard or by pulling it towards the driver.

4. Headlight flasher

High beams can be flashed momentarily by pulling the lever completely towards the driver and then releasing it.

5. Courtesy-type blinkers

Clearance lights (blinkers) can be operated by pressing the button located at the tip of lever.

6. Washer controls

Push the external ring at the end of lever towards the steering column to activate windshield washers. When the ring is released, washers stop immediately but wipers will continue to run twice over to dry windshield.

WARNING: In cold weather, windshield should first be warmed up with defroster before using washers, in order to prevent icing and serious visibility impairment.

CAUTION: To avoid damaging pump mechanism, never operate washers when windshield washer fluid level is insufficient.

7. Windshield wipers

Turn lever forward to activate the two (2) elect/synchro arms; the first position corresponds to low speed and the second to high speed. Turn lever backwards to activate intermittent mode.

CAUTION: Do not run wiper blades on dry windshields as this may cause scratches. To avoid damaging wiper mechanism, always loosen frozen blades from windshield before operating wipers.

Electric horn

Can be activated by pressing button in center of steering wheel.

Transmission retarder lever (Optional)

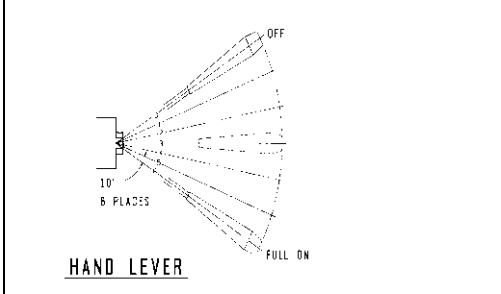

18018

Located on R.H. side of steering column. Use lever to select transmission's retardation level ("OFF" or 1 to 6). For system description, see page 4-5.

FOOT-OPERATED CONTROLS

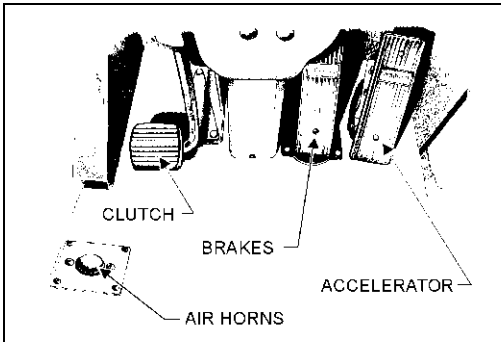

18118

AIR HORNS

Use the air horns only on highways. Air is released and the horn is activated when the push-button valve, located on the floor at driver's L.H. side, is depressed.

CLUTCH PEDAL

Used to engage and disengage the manual transmission.

BRAKES

Service brakes

This vehicle is equipped with a dual braking system, the front brakes being independent of the rear brakes. Normally both systems are activated by the single brake pedal. This brake system becomes a modulated emergency system if a pressure drop occurs in the rear brake system.

Service brakes are applied by depressing the brake pedal, the rate of braking varying according to the gradual increase of pressure until the required rate of braking is obtained. When brake pedal is depressed, vehicle stoplights automatically light up.

For system information, see "BRAKES" on page 3-1.

Combination emergency and parking brakes

The spring-loaded, manually operated parking brake is activated by pulling up on the control valve knob located on R.H. lateral console (see item #2 on page 2-20).

This same brake system will automatically be applied in an emergency situation, whenever the control valve supply pressure drops below 40 psi (275 kPa).

For system information, see "BRAKES" on page 3-1.

ACCELERATOR PEDAL

Controls engine rpm.

NOTE: Pedal will be inoperative when the "DDEC-TEST" switch in steering compartment is in the "ON" position.

TILT STEERING WHEEL AND TELESCOPIC STEERING COLUMN

To unlock, use the handle located on the steering column's left hand side. Pull handle down to permit a maximum variation of 11° in steering wheel angle, and a telescopic wheel movement of 2" (5 cm). Push handle up to lock both mechanisms.

WARNING: Never try to adjust the steering wheel while the vehicle is in motion; wheel could move unexpectedly, making you lose control of the vehicle.

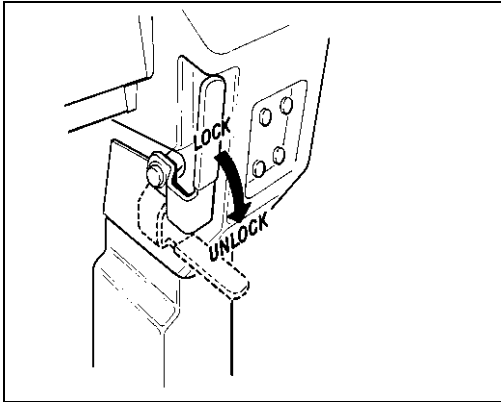

18027

ENTRANCE DOOR

Inside operation

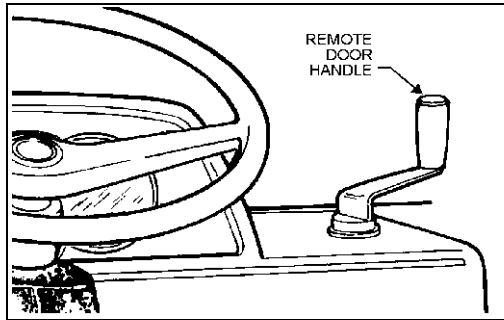

18119

Entrance door is supplied with an air-operated locking system. The door is opened and closed

by a handle, mounted directly on the dash to the driver's right, which automatically activates the air-operated lock. Handle must be turned counterclockwise to open door and clockwise to close.

CAUTION: Door handle must be fully pushed in (clockwise) to ensure that air locking mechanism has properly closed door. Door handle should be manipulated slowly to prevent damage to the air locking system components.

Emergency opening

In the event of a malfunction in the door air lock mechanism, press the door override button on R.H. Lateral Console (see page 2-20 & 3-4).

Outside operation

Open the door from the outside by first depressing push-button on L.H. side of door and then pulling on door handle. To close, simply push in door; air locking system will automatically be activated and will complete closing. Use supplied key (see page 2-1) to lock door from the outside.

CAUTION: Before closing door from the outside, make sure keylock is in the unlocked (fully counterclockwise) position so as to avoid damage to the mechanism.

NOTE: When opening door, the stepwell lights will turn on if exterior lighting switch (see page 2-16, item #3), located on R.H. Lower Switch Panel, is "ON".

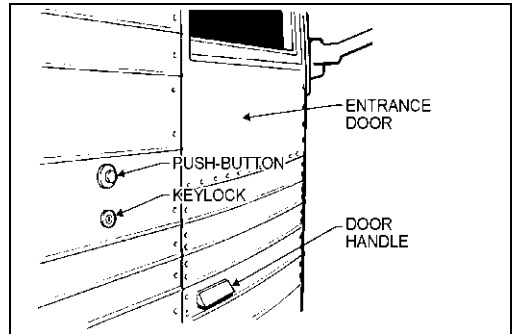

18120

SEATS

Driver's seat - "ISRI"

Two distinct "ISRI" model driver's seats may be supplied with your vehicle: one with mechanical suspension (std), and the other with a sophisticated air suspension system (opt). Both seats may be equipped with lumbar supports and adjustable armrests. Seats can be adjusted to the desired driving position by following the instructions listed below:

Seats prior V.I.N. 2P9L33490S1001497

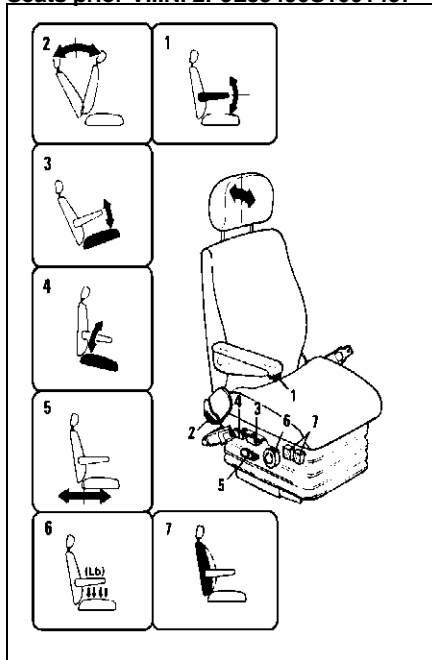

18026B

WARNING: Never try to adjust seat while driving vehicle as this could result in loss of vehicle control.

NOTE: Seat controls can be located either on the seat's L.H. or R.H. side.

1. Rotate control knob to select desired armresting angle. When not in use, raise armrest parallel with backrest.

2. Lift lever to select proper adjustment angle of backrest.

3. Pull handle up, and push down or pull up on front of seat cushion to raise or lower the front section of seat cushion.

4. Pull handle up, and push down or pull up on rear of seat cushion to raise or lower the rear section of seat cushion.

WARNING: Before proceeding with seat cushion adjustments, lower seat belt retractor to avoid pinching fingers between retractor and control knobs.

5. Pull handle up and slide seat forwards or backwards to adjust distance between driver and dashboard.

NOTE: This control may also be located at the front of the seat (lever no. 8).

6. For maximum suspension performance, rotate handwheel until your body weight is selected on indicator.

NOTE: On "ISRI" seat equipped with air suspension, the suspension is self-adjusting to the weight of the driver, thus deleting the suspension adjustment handwheel (6).

7. Push on upper section of rocker switches to inflate lumbar support bellows inside the seat backrest, and push on lower section of rocker switches to deflate bellows.

NOTE: Rear and front rocker switches are respectively for lower and upper lumbar support bellows.

Seats from V.I.N. 2P9L33490S1001497

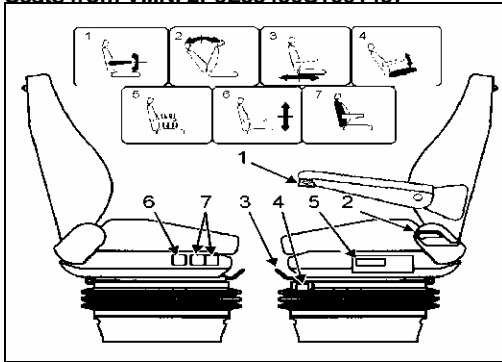

18026C

WARNING: Never try to adjust seat while driving vehicle as this could result in loss of vehicle control.

1. Rotate control knob to select desired armresting angle. When not in use, raise armrest parallel with backrest.
2. Lift lever to select proper adjustment angle of backrest.
3. Pull handle up and slide seat forwards or backwards to adjust distance between driver and dashboard.
4. Pull handle up, and push down or pull up on front of seat cushion to raise or lower the front section of seat cushion.
5. For maximum suspension performance, push down on knob until required weight is reached.
6. Press on "+" or "-" to respectively raise or lower driver's seat.
7. Push on upper section of rocker switches to inflate lumbar support bellows inside the seat backrest, and push on lower section of rocker switches to deflate bellows.

NOTE: Rear and front rocker switches are respectively for lower and upper lumbar support bellows.

Seat belts - Driver's seat

Each driver's seat is equipped with a retractable seat belt as required by State, Provincial and Federal regulations. To fasten, pull seat belt out of the retractor and insert the latch plate into the buckle until it clicks. No special adjustment is required since the reel device is self-adjusting. If seat belt operation becomes defective, report to Manufacturer's Service Center.

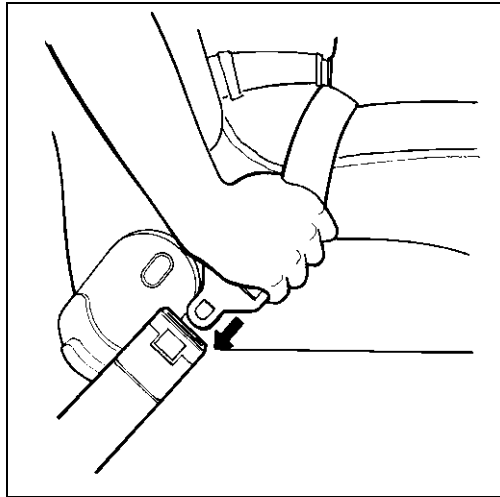

18028

NOTE: The seat belt must be pulled out slowly and continuously, otherwise it will lock the reel before the latch plate reaches the buckle. If this happens, allow the belt to retract completely and repeat the procedure correctly.

WARNING: A snug fit with the lap belt positioned low on the hips is necessary to ensure motorist's safety. Belt should not be worn twisted; avoid pinching belt and/or belt hardware in seat mechanism. Do not wear belt over rigid or breakable objects, such as eyeglasses, pens, or keys as these may cause injuries.

CAUTION: Never bleach or dry clean safety belt.

To unfasten belt, press red button in center of buckle and allow belt to retract. If belt does not fully retract, pull it out and check for kinks or twists. Make sure that it remains untwisted as it retracts.

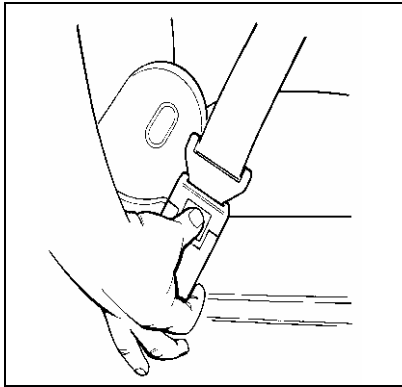

18029

WARNING: Seat belts should always be worn by motorists using seats supplied with belts since this is required by most State and Provincial laws.

Passenger seats

Passenger seats may be equipped with grip handles, ashtrays, newspaper holders, tables, and footrests.

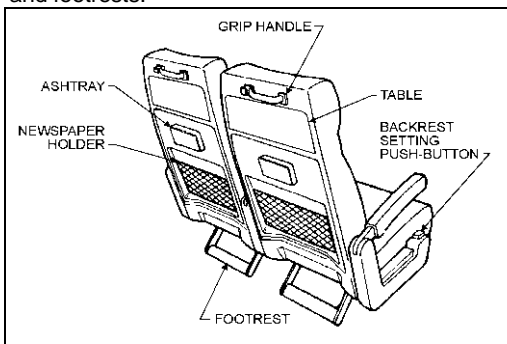

18121

All seats are track-mounted so that the seating configuration can be changed (2 + 2 or 2 + 1). Each seat is mounted on oval aluminum pedestals to make it easier to clean between the pedestal and side wall.

Passenger seat backrests can be tilted by using the push-button located on the side of the seat cushion. Depress and hold push-button, then adjust backrest to the desired angle. Release

push-button to lock backrest in position. The hydraulic seat back adjustment mechanism is equipped with a pull-off spring.

One folding armrest is installed on the aisle side of the passenger seat and is spring-loaded to lower automatically. The other folding armrest is located between the two seats and can be raised for passenger convenience. A fixed armrest is installed on the window side of the seat.

Swivel seats

The coach can be equipped with two optional sets of swivel seats to allow installation of card tables. The swivel seat can be rotated for passenger privacy. To rotate seats, unscrew the wing nut from under each seat cushion then remove cushions. Remove the four wing screws, pull seats toward the aisle and rotate the seat counter-clockwise. Align mounting holes, secure with wing screws and install seat cushions.

NOTE: Instructions for making swivel seat adjustments are affixed on the rear frame under the seat cushion.

Tour guide seat (Optional)

The optional tour guide seat is installed on driver's R.H. side over front steps. The seat folds up automatically when host/hostess stands up for convenience when embarking and disembarking passengers.

The tour guide seat can easily be removed and stored in parcel racks by simply lifting and unhooking seat assembly.

MIRRORS

Interior mirror

The interior rearview mirror is located between windshields, above driver's area. It enables the driver to see passenger circulation in the aisle. Adjust to desired viewing angle by hand without loosening screw.

Exterior mirrors



Optional (RAMCO) mirror 18036

Your vehicle is equipped with two (2) exterior mirrors that may be supplied with an optional electric heating system which serves to minimize ice and condensation in extreme weather conditions. Integral thermostats are installed in both mirrors to avoid continual heating. Use the appropriate switch on the L.H. side control panel (item #6 on page 2-4) to activate the defroster system on both mirrors simultaneously.

The optional "RAMCO" mirrors can easily be adjusted by using the remote controls located on L.H. side control panel (items #16 & 17 on page 2-4).

The standard mirrors can be manually adjusted as per the following method:

To obtain desired vehicle width, adjust the mirror arm angle by loosening the adjusting "Allen" screw (item #1) located at body end of mirror arm. Adjust mirror arm to desired position, then tighten adjusting screw.

CAUTION: Do not overtighten.

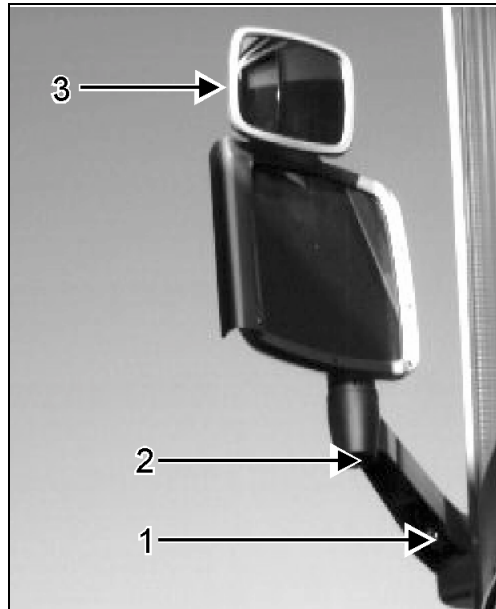

Standard mirror 18035

Mirror head can be rotated and/or tilted by loosening the adjusting "Allen" screw (item #2) located at the base of mirror head. Adjust to desired position, then tighten adjusting screw.

CAUTION: Do not overtighten. Do not install a convex mirror on the heated mirror glass. This prevents even distribution of heat in the heated mirror and could cause the glass to break.

Convex mirror head can be rotated and/or tilted by loosening the adjusting nut (item #3) located at the rear of mirror. Adjust to desired position, then tighten adjusting nut.

CAUTION: Do not overtighten.

WARNING: Objects in convex mirror are closer than they appear.

Mirrors should not extend beyond body of coach any more than necessary.

NOTE: It is important for safe driving that you have good rear vision on each side of the vehicle; therefore, adjust mirrors **before** driving and immediately after adjusting your seat.

EXTERIOR COMPARTMENTS (XL-40)

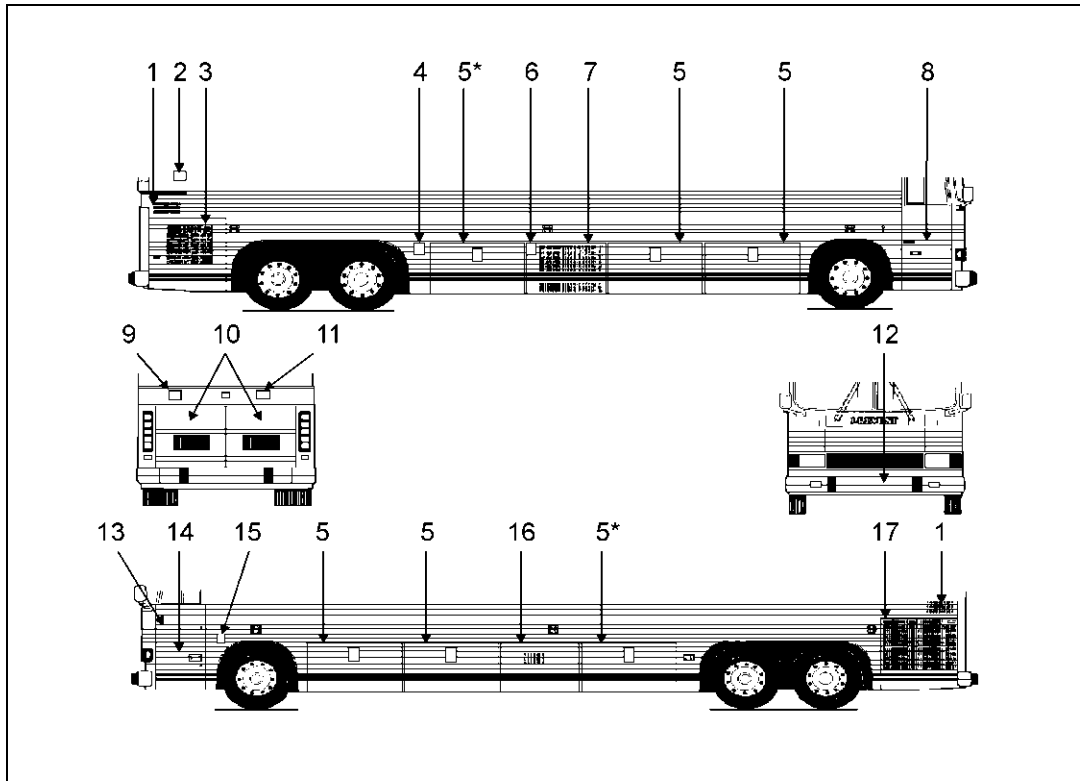

18030A

- | | |
|--|---|
| 01..... Engine air intake duct | 10..... Engine rear doors |
| 02..... Lavatory access door | 11..... Engine oil reserve tank filling, Block heater plug & (Water heater plug [Optional]) |
| 03..... Engine R.H. side door | 12..... Spare wheel & tire compartment |
| 04..... Main battery disconnect switch door | 13..... Front electrical compartment |
| 05..... Baggage compartment (* = Access to battery compartment) | 14..... Steering compartment |
| 06..... Fuel tank filling door | 15..... 110 volt interior lighting (Optional) |
| 07..... Condenser or Baggage compartment | 16..... A/C & Heating or Baggage compartment |
| 08..... Entrance door | 17..... Engine L.H. side door |
| 09..... Coolant surge tank filling door | |

The above figure identifies all exterior compartments and access doors. See page 2-33 for securing and accessing procedures.

NOTE: If doors are supplied with locks, refer to page 2-1 to select the appropriate key.

EXTERIOR COMPARTMENTS (XL-45)

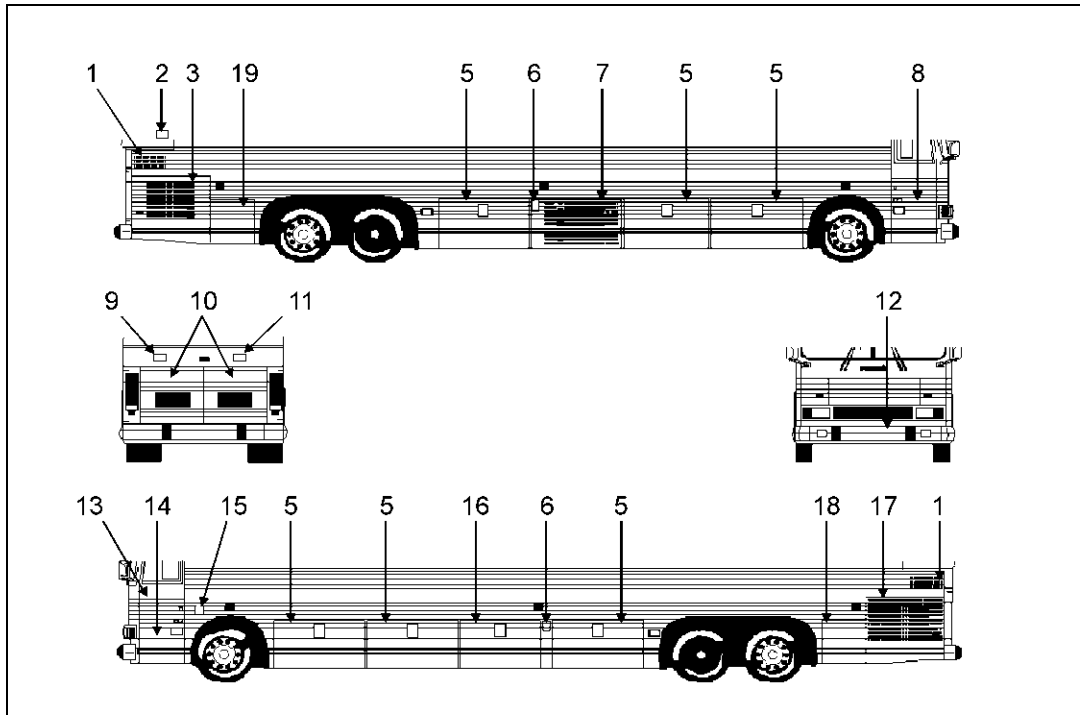

18031A

- | | |
|--|---|
| 01..... Engine air intake duct | 11..... Engine oil reserve tank filling, Block heater plug & (Water heater plug [Optional]) |
| 02..... Lavatory access door | 12..... Spare wheel & tire compartment |
| 03..... Engine R.H. side door | 13..... Front electrical compartment |
| 04..... N/A | 14..... Steering compartment |
| 05..... Baggage compartment | 15..... 110 volt interior lighting (Optional) |
| 06..... Fuel tank filling door | 16..... A/C & Heating or Baggage compartment |
| 07..... Condenser or Baggage compartment | 17..... Engine L.H. side door |
| 08..... Entrance door | 18..... L.H. side rear service compartment |
| 09..... Coolant surge tank filling door | 19..... Main power compartment |
| 10..... Engine rear doors | |

The above figure identifies all exterior compartments and access doors. See page 2-33 for securing and accessing procedures.

NOTE: If doors are supplied with locks, refer to page 2-1 to select the appropriate key.

Engine compartment doors

(doors #3 & 10)

For access to the engine compartment, two rear doors and one R.H. side door are provided. To open rear doors, turn lock release handle counterclockwise and pull open doors. Doors are held in open position by a mechanical locking device located at top of each door.

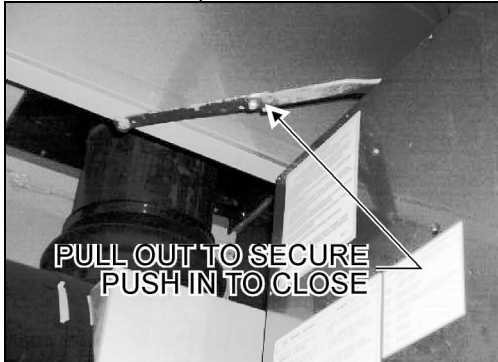

01009

A switch located on R.H. side of rear junction box can be used to actuate the engine compartment lights.

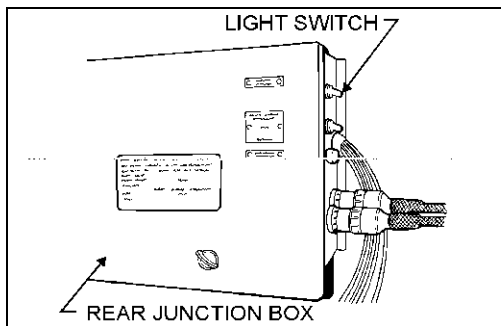

01010

To close doors, first release mechanical locking device by pushing in with fingers, then return doors to closed position; always starting with left (driver's side) door.

The side door can be opened by pulling the release handle and then pulling on the door.

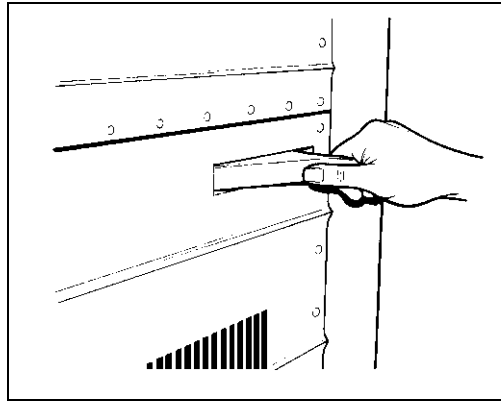

18037

The engine L.H. side compartment door, which opens similarly to the R.H. side compartment door, is designed to provide access to the radiator.

Engine air intake ducts

(items #1)

Engine air intake ducts are not accessible; they are designed only for engine compartment air circulation.

Fuel tank filling door

(door #6)

Fuel filler neck is accessible by simply pulling out door's R.H. side finger notch.

Note: *XL-45's have filler necks on both sides of vehicle.*

Entrance door

(door #8)

See instructions on page 2-26.

Engine compartment components

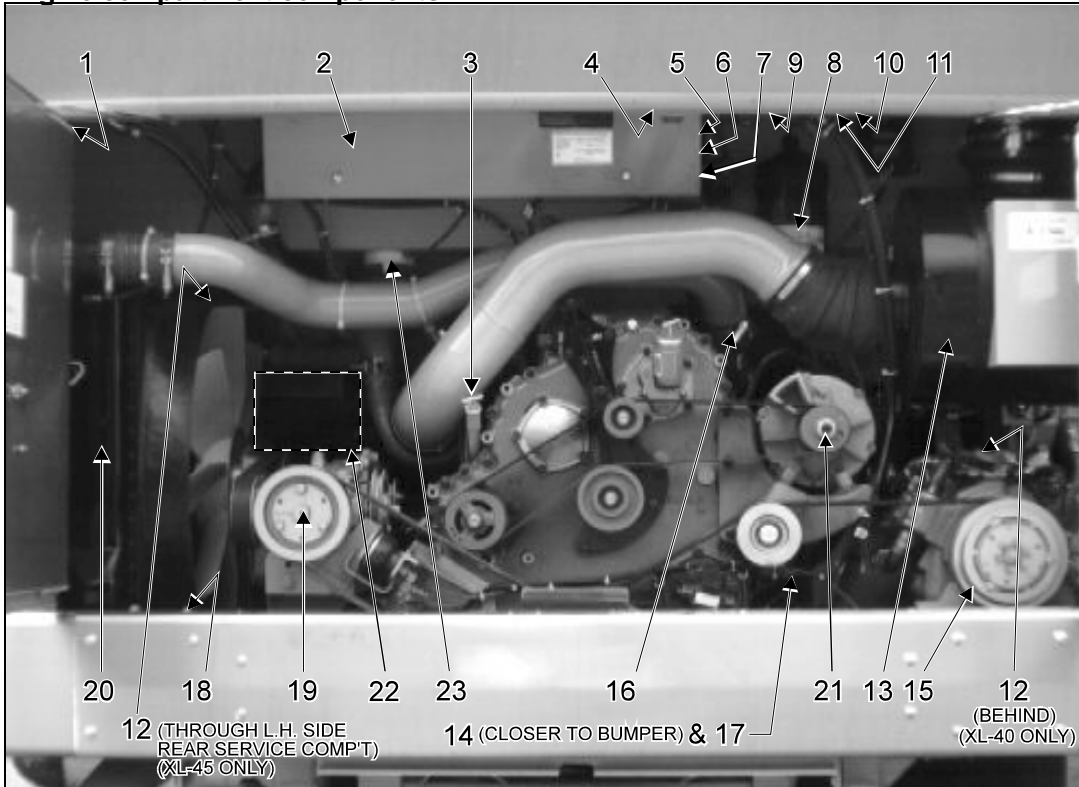

01014A

Component identification:

- | | |
|---|---|
| 01.....Coolant surge tank | 12.....Preheater (Webasto or Espar) |
| 02.....Rear junction box | 13..... Engine air cleaner |
| 03..... Transmission oil dipstick (Auto. trans. only) Engine oil dipstick (Manual trans. only) * | 14..... Engine primary fuel filter |
| 04..... Belt tensioning pressure control valve | 15..... A/C compressor (Central system) |
| 05..... Engine compartment light switch | 16..... Engine oil dipstick (Auto. trans. only) |
| 06..... Starter selector switch | 17..... Engine secondary fuel filter |
| 07..... Rear start push-button switch | 18..... Muffler |
| 08..... Power steering oil tank | 19..... Radiator fan gearbox |
| 09..... Engine oil pressure gauge | 20..... Radiator |
| 10..... Engine oil temperature gauge | 21..... Alternator 24V 270A |
| 11..... Engine oil reserve tank | 22..... A/C compressor (Auxiliary system) |
| | 23..... Fire detector |

(*) - There is no Manual Transmission Dipstick; to check oil level, use the fill plug located on transmission (see page 6-5).

Baggage compartment

(doors #5 - Also #7 & 16 if applicable)

An optional elect. door locking system may be installed on all baggage compartment doors. The switch is located on the L.H. side control panel (see item # 3 on page 2-4). Push up rocker switch to unlock the doors and push down to lock. An indicator light will illuminate on dashboard if one (1) or several baggage compartment doors are unlocked.

The baggage compartment doors may also be locked or unlocked from outside using the key provided (see "KEYS" on page 2-1)

To open a baggage compartment door, insert fingers under lower edge of operating handle, pull out and up to unlatch door, grab handle rod and pull up compartment door. The opening action is assisted by gas cylinders which also hold the door in the open position.

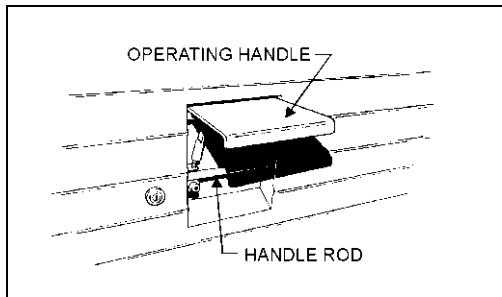

18043

Opening of baggage door will actuate a microswitch that will turn on the compartment lights.

NOTE: In case of malfunction or special conditions, use the safety lock to keep the door securely opened.

To close a baggage compartment door, first release safety lock, then pull handle rod out and down as far as door will allow, then push down handle to complete procedure and latch door.

WARNING: Always open and close baggage compartment doors using the handle rod ONLY. Keep hands off all door edges.

CAUTION: Do not slam baggage compartment doors. This can only damage door weather stripping and/or locking mechanism.

NOTE: To prevent theft and/or vandalism, always lock baggage doors before leaving vehicle.

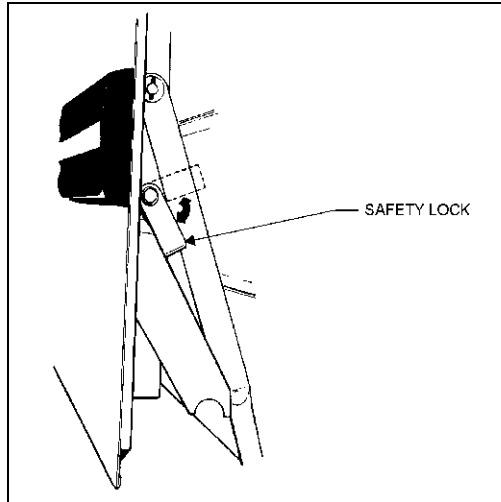

18038

Spare wheel & tire compartment

(door #12)

The front bumper is of the "reclining-type". To open, carefully remove the large bolt at each end using the wheel nut wrench, then slowly lower the bumper (see also, pages 4-19 & 5-2).

WARNING: This compartment has not been designed for storage. Never leave any loose objects in this area since they may interfere with steering linkage mechanism.

Additional care should be taken when opening this compartment since bumper weights 100lbs (45kg).

CAUTION: After compartment panel has been secured, the two (2) bumper retaining bolts should be checked to make sure they are tightly fastened.

A/C & heating and Condenser compartment doors
(doors # 7 & 16)

The A/C & heating and Condenser compartment doors can be opened manually or mechanically, depending on options. Open the door manually by first, removing the "Phillips" retaining screws (qty = 2) and then pulling on side of door where screws are located.

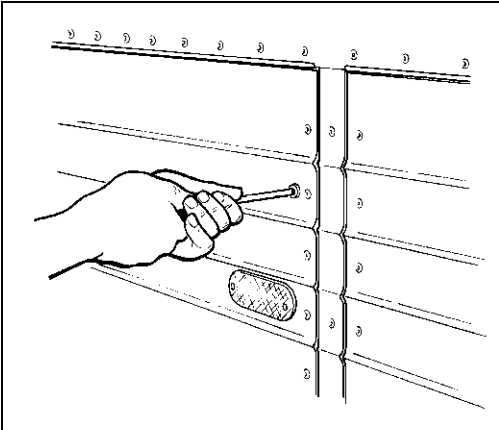

18039

Open the door mechanically by first opening the Baggage Compartment aft of A/C or Condenser Compartment, then pull on door knob (see fig. below).

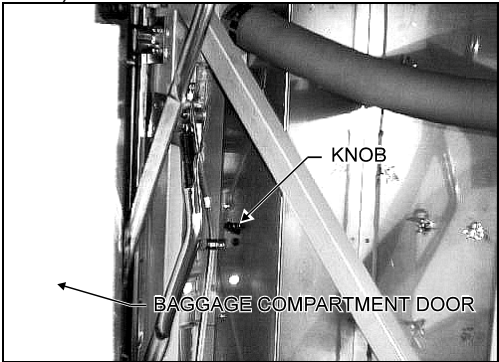

18056

Service doors
(doors #2,9,11,13 & 14)

Service doors can be opened by turning the slotted head "Dzus" fasteners 1/4 turn counterclockwise and then pulling on the door.

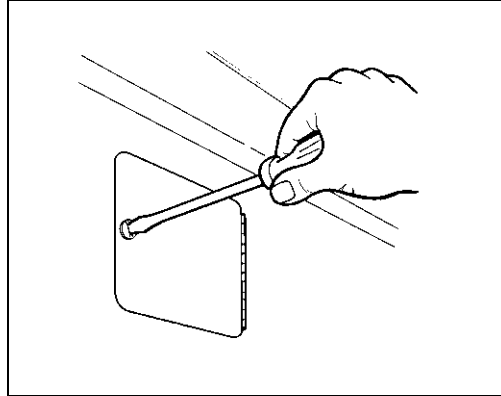

18044

Doors #13 & 14 are each provided with a microswitch which when actuated, will turn on compartment light.

CAUTION: Special care must be taken not to damage the paint around the "Dzus" fasteners when using a screwdriver or a coin.

L.H. side rear service compartment and main power compartment (XL - 45 only) (doors #18 & 19)

To access these compartments, use key provided (see "KEYS" on page 2-1). To secure, simply push in door.

WARNING: These compartments are designed to give access to compartment components only and cannot be used for storage.

Battery compartment (XL-40 only)
(access through door #5 with *)

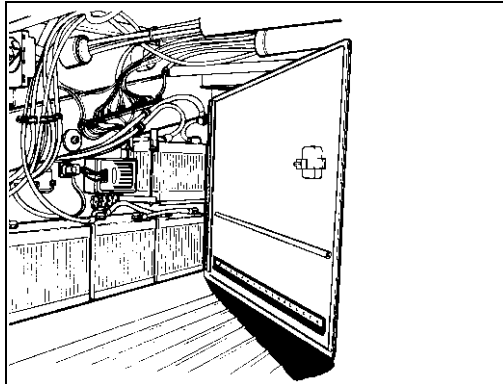

06103

Batteries are accessible by means of an access door which is located on the back wall of the rear baggage compartment (#5*). To open battery access door, simply take out handle from it's cavity, turn 1/4 turn counterclockwise and pull on the handle.

INTERIOR COMPARTMENTS

Lavatory

The lavatory is located in the rear R.H. corner of coach and may be equipped with the following items:

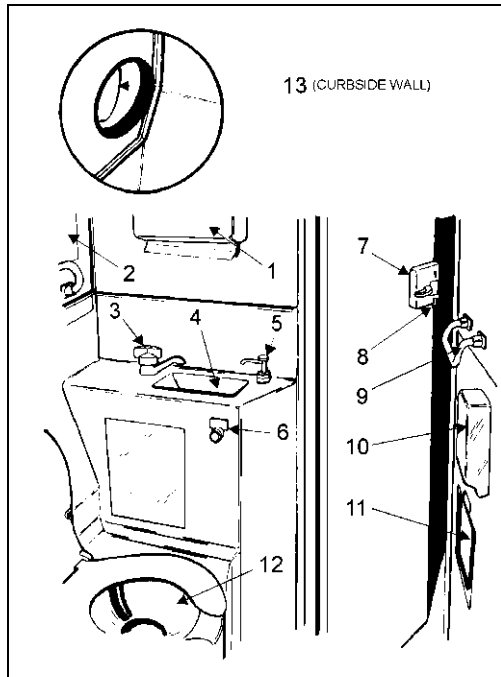

23015

- 01..... Towel dispenser
- 02..... Mirror
- 03..... Water supply valve (faucet)
- 04..... Washbasin
- 05..... Liquid soap dispenser
- 06..... Flush button (timed)
- 07..... Door handle
- 08..... Door lock
- 09..... Grip handle
- 10..... Hygienic toilet tissue dispenser
- 11..... Waste paper container (trap)
- 12..... Toilet
- 13..... Access door (cleaning)

Locking the lavatory door from the inside will illuminate a incandescent light in the lavatory, an exterior "occupied" sign and an indicator light on Dashboard (see item #4 on pages 2-9 & 10). Compartment night-light is lit when vehicle headlights are "ON".

If emergency assistance is required, the lavatory occupant can actuate a buzzer that will sound in

driver's area. The buzzer's push-button (c/w instruction label) is located on the inner curbside wall of lavatory.

The lavatory has its own ventilation system that operates only when ignition switch is in the "ON" position.

An auxiliary sump tank (optional) allows main tank to be drained by manually opening an interconnecting tank valve. Lavatory can then be operated for longer periods until coach can be serviced at a facility equipped for disposal.

The fresh water tank, located behind compartment mirror, may be equipped with a thermal drain valve that will drain the tank when water temperature approaches the freezing point preventing damage to the tank. An immersion water heater for the lavatory fresh water tank is also available; it can be connected to a 110-120 volt AC power source through an extension cord by the engine oil reserve tank filling door (see item 11 on page 2-31 & 32).

An access door is also provided on curbside wall to facilitate lavatory compartment cleaning. This door can only be opened from the outside. For reservoir draining and filling, see page 6-11.

Parcel racks

Passenger carry on luggage is stored in overhead compartments on each side of the coach. An optional video cassette player can be installed in the first or second front L.H. side parcel rack.

To open the closed-type parcel racks, pull the door handle up to release the latch, then lift the door open. A pressurized cylinder mechanically assists in opening the door and also holds it open.

NOTE: An optional lock can be installed on video system parcel rack door. See page 2-1 for key selection.

Safety equipment compartment



The safety equipment compartment, located above L.H. side of entrance stairwell, includes a first aid kit and may also include a fire axe.

To open access door, turn button counterclockwise, lightly pull on button, then (while holding door with both hands) slide door towards center of vehicle. Reverse procedure to close door.

ACCESSORIES

Back-up camera/TV monitor (Optional)

The back-up camera/TV monitor system provides the driver with visual assistance when backing-up.

The monitor is located on post between driver's window and windshield.

The system switches on automatically when the transmission is put in the reverse (R) range.

Driver's window

Pull handle towards you to unlock, then slide window open. Reverse operation to close window.

Destination sign (Optional)

To change the name on your destination sign simply pull to unlock handle and rotate until sign shows desired destination. Release handle to lock.

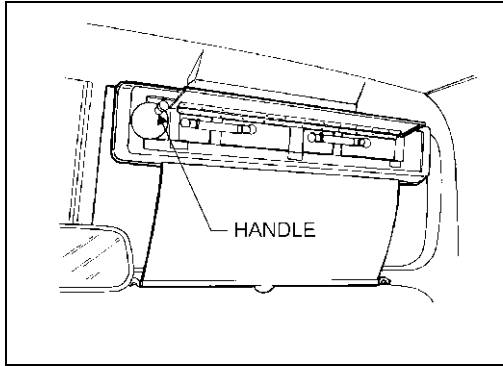

23017

NOTE: The destination sign is equipped with a light which illuminates automatically when the headlight or fog light switch is activated.

Also, the driver's name can be written on an optional nameplate holder on destination sign.

License holder

A license holder is provided on L.H. side of driver below control panel switches. Holder can also be used for your warranty registration card.

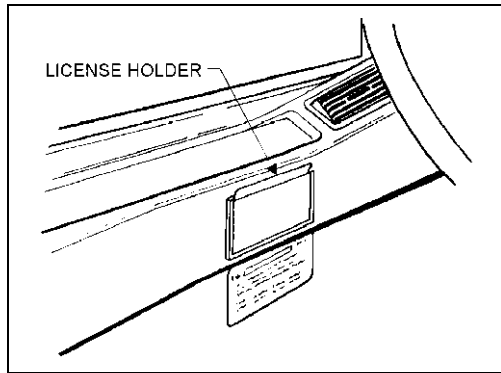

23018

Driver's fan (Optional)

Driver's fan is mounted on dashboard and can be used to help defrost windshields or just give driver's area extra air circulation. Loosen the wing nut to redirect fan. ON/OFF switch is located on fan base.

Microphone jacks

There are two (2) standard PA system microphone jacks installed on vehicle; one just below driver's L.H. side control panel and the other on central console. Five (5) optional microphone jacks can be installed in the following locations:

- One on back of modesty panel.
- One on back of driver's guard.
- One on R.H. lateral panel.
- One on lavatory's exterior front wall.
- One on parcel rack of owner's choice.

NOTE: The PA system is equipped with a stereo attenuator and a volume control.

Interphone (Optional)

Use the Interphone for communications between driver and host/hostess. Master receiver is located in driver's area and secondary receiver is installed on lavatory exterior front wall. To use system, simply unhook receiver and press button

identified with an asterisk (*); buzzer will sound at other end.

Driver's coat hook

Driver's coat hook is located on post at rear upper left side of driver.

WARNING: Make sure coat is securely hooked and that it will not impair driver vision and movement.

raise blind, simply unhook bar then slowly lift blind.

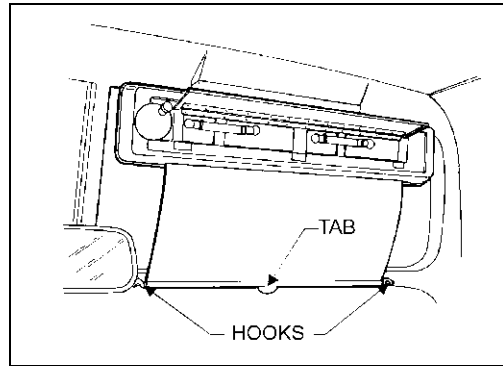

23020

Waste container

Passenger area waste container is located at rear of vehicle in between lavatory front wall and passenger seats.

Blinds

The driver's area may be supplied with three blinds: one (1) on driver's side window and two (2) on windshield.

To operate driver side window and L.H. windshield blinds, pull down tab to the required position and then release; the blind will remain in position. To raise blind, pull on release cord on it's L.H. side.

Each passenger window may also be provided with a blind. Pull shade and lock in first or second hook, as desired.

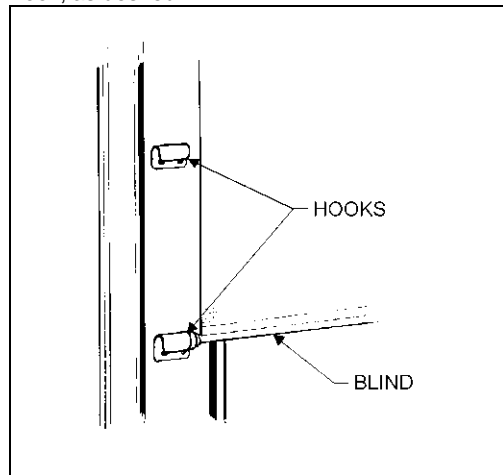

23021

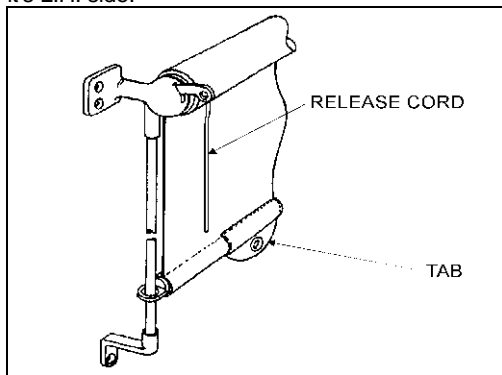

23019

To operate R.H. windshield blind, pull down tab and position bar in hooks on central beam. To

Adjustable A/C & heating louvers

The vehicle is supplied with five (5) adjustable A/C & heating louvers. These can be adjusted manually so the heated or cooled air flow can be directed as desired.

Adjustable louvers are located as follows:

- One on L.H. side control panel.
- Two on L.H. side of driver's seat.
- One on center console.
- One over steps, near entrance door.

NOTE: The louver on L.H. side control panel can be used to defrost driver's window or airflow can be directed towards driver.

Mud flaps & splash guards

Mud flaps are installed behind front and tag axle wheels in order to minimize dirt on the lower panels of vehicle and to reduce stone projections on vehicles behind you. Optional splash guards may also have been installed behind each dual wheel of the drive axle in order to reduce stone projections on tag axle wheels.

Stop/Service/Reading lamp

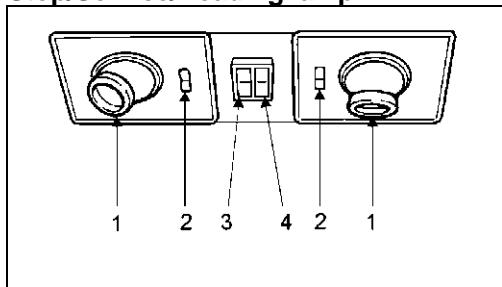

23022

1. Reading lamp

Can be adjusted manually to desired angle.

2. Reading lamp switch

Press to turn reading lamp ON or OFF.

3. Hostess signal switch

Depress rocker switch to activate chime in driver's area. A light illuminates inside rocker switch to indicate passenger position to the hostess.

4. Driver's signal switch

Depress rocker switch to activate chime in driver's area indicating to driver the passenger's intention to disembark.

"Quick-Lounge" system (Optional)

"Quick-Lounge" is a quick-fit modular system providing luxurious seating accommodations for passengers.

This system occupies the same space as the

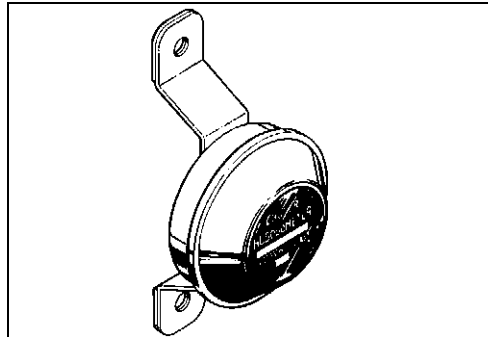

23024

paired seating configuration it replaces. The existing seat spacing remains unchanged.

Card tables

Two (2) card tables are supplied as standard equipment and are used in the passenger swivel seat configuration. The card tables are stored in the parcel racks in separate stowage bags.

To install the card table, hold it at 45° (degrees) to the side wall. Insert the spring-loaded pin first into the hinge, then insert locking pin. Push on the locking clamp to release the leg; then unfold leg until clamp locks into place.

Galley (Optional)

The Mini-Chef galley can include features such as a microwave oven and refrigerator to accommodate hot/cold food and beverage service. The galley's electrical power circuit is activated by a rocker switch located on L.H. side control panel (see item #14 on page 2-4).

Hubodometer (Optional)

A wheel hubodometer can be installed on the R.H. side of the drive axle. It indicates the total distance in miles or kilometers covered by the coach since leaving the factory, including road testing.

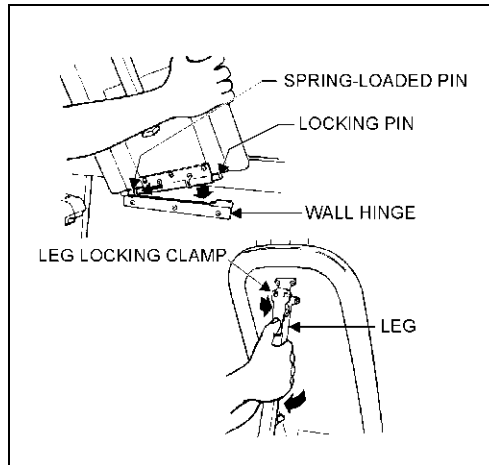

23023

Spare Parts Kit

A Spare Parts Kit is supplied with your vehicle; parts are stored in a cardboard box located inside the forward baggage compartment.

Kit contents depend on certain vehicle options as shown below:

- 1 = Series 60 Engine + Full A/C System.
- 2 = Series 60 Engine + Full A/C System + 110 volt interior lighting.
- 3 = Series 50 Engine + Full A/C System.
- 4 = Series 50 Engine + Full A/C System + 110 volt interior lighting.

| Part No. | Description | QTY | Option No. | | | |
|----------|--------------------------|-----|------------|---|---|---|
| | | | 1 | 2 | 3 | 4 |
| 561122 | Light Bulb, 24V | 2 | X | X | X | X |
| 561166 | Light Bulb #464, 24V, 3W | 2 | X | X | X | X |
| 562278 | Light Bulb, 24V, 10W | 4 | X | X | X | X |
| 561707 | Relay, 24V | 1 | X | X | X | X |
| 561797 | Circuit Breaker, 3 Amp | 1 | X | X | X | X |
| 561790 | Circuit Breaker, 6 Amp | 1 | X | X | X | X |
| 561791 | Circuit Breaker, 8 Amp | 1 | X | X | X | X |
| 561792 | Circuit Breaker, 10 Amp | 1 | X | X | X | X |

CONTROLS/INSTRUMENTS

| Part No. | Description | QTY | Option No. | | | |
|----------|---|-----|------------|---|---|---|
| | | | 1 | 2 | 3 | 4 |
| 561793 | Circuit Breaker, 15 Amp | 1 | X | X | X | X |
| 561794 | Circuit Breaker, 20 Amp | 1 | X | X | X | X |
| 561795 | Circuit Breaker, 25 Amp | 1 | X | X | X | X |
| 561880 | Light Bulb, 12V, 21W | 3 | X | X | X | X |
| 561881 | Light Bulb, 12V, 10W | 2 | X | X | X | X |
| 561882 | Light Bulb, 12V | 1 | X | X | X | X |
| 506690 | V-Belt, AX-74 | 3 | X | X | | |
| 506688 | Belt, Multi-V | 1 | X | X | X | X |
| 506669 | Belt, Poly V12 | 1 | X | X | X | X |
| 506664 | Belt, BX-97 | 2 | X | X | X | X |
| 061204 | Cable assy (110 volt interior lighting) | 1 | | X | | X |
| 506691 | V-Belt, AX-73 | 3 | | | X | X |

**PREHEATING SYSTEM
TIMERS (AUXILIARY)** (Optional)

The timer, located on R.H. lateral console (see page 2-20 items 5 & 5A), is used to program the starting and stopping time of the preheating system. One of two optional Timers may be installed in your vehicle, Espar (40 000 BTU) or Webasto (80 000 BTU). The system indicator light, located on dashboard (see item #28 on page 2-9) illuminates when system is functional. The following offers system descriptions for both Timers.

CAUTION: *The preheating system should not operate for more than one hour before starting engine as this could discharge batteries.*

WARNING: *Preheating system must not operate when vehicle is parked inside or during fuel fill stops.*

NOTE: *Preheating system uses the same fuel as the engine.*

In case of failure:

1. Shut off and turn on again.
2. Check main circuit breaker and overheating switch (Espar) or overheat fuse (Webasto).
3. Have system repaired in a specialized shop.

ESPAR (40 000 BTU)

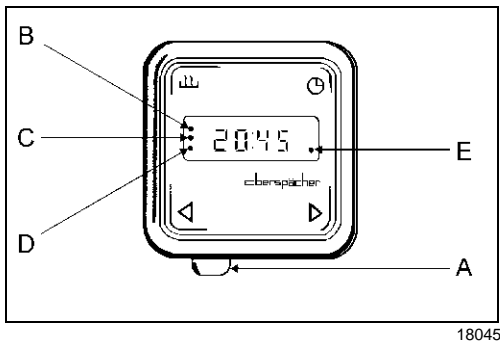

18045

Time display

Pull lever "A" forward*.

Time setting

Pull lever "A" forward and press on < or on >.

Heating startup

(possible regardless of preselection)

Press on 35 .

Display of heating time in minutes, operation indicator light "E" is flashing.

Heating startup, continuous operation

Pull lever "A" forward and press simultaneously on 36 .

Heating shutoff

Press on 37 . Fan has automatic delay to allow cooling.

Preselection of heating startup time

Memorization of three (3) startup times.

Display of memorized times

NOTE: Heating will turn on automatically at preselected time. Press once on 38: Heating is

set for the 1st startup time**, indicator light "B" is on. Press twice on 39: Heating is set for the 2nd startup time**, indicator light "C" is on. Press three times on 40: Heating is set for the 3rd startup time**, indicator light "D" is on. Neutral position: Press four times on: No display or display of time*. No preselected startup time.

Setting of startup times:**

1st memory: Press momentarily on "B" is on. 2nd memory: Press momentarily on 41, "C" is on. 3rd memory: Press momentarily on 42, "D" is on.

Setting of time by pressing on < or on >

Neutral position: Press once again on 43: No display or display of time*, the preset times are still in memory.

- * - Eventually permanent display of time with the vehicle ignition switch on.
- ** - Display of heating startup time turns out after approximately 20 seconds, or time delay*.

WEBASTO (80 000 BTU)

OPERATION WITH DIGITAL TIMER

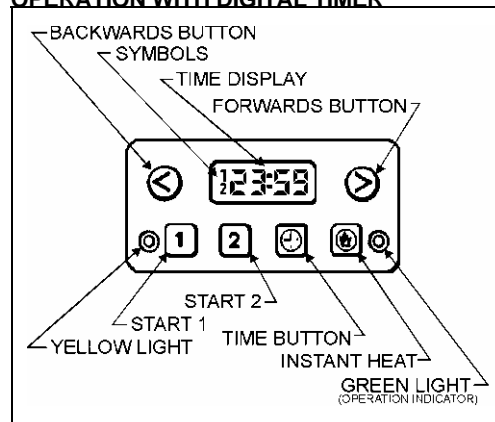

18046

1. To set the clock

If the time display e.g. 18:33 is wrong, or if it flashes 8:88, press button 44 and at the same

time press either ⏪45 (backwards) or ⏩46 (forwards). The longer you hold the button down, the quicker the display changes. The last few minutes are set accurately by quick pushes. Adjust to get exact time, e.g. 23:59. The display fades after 20 secs.

2. Do you want to know the time?

Just press ⏸47 at any time. The display appears again.

3. You can get instant heat...

with the button ⏻48, which switches your heater on (or off) immediately. The green light is on while the heater is switched on.

4. ... or you can program the heater to come on up to 24 hours ahead. Press button 49 - and the display shows the time at which the heater will start. You can alter starting time by pressing button ⏪50 (backwards) or ⏩51 (forwards). The longer you press the button, the faster the display changes. The last few minutes are set accurately by quick pushes. The display fades after 20 secs. The symbol 1 remains in the display, and the yellow light stays on. Your starting time is now activated.

5. Button 52 allows you to program a second starting time

Press button ⏸53, which de-activates starting time 1. Then proceed as in (4).

The activation of the second starting time is indicated by the symbol 2.

6. Do you want to check (or activate) your starting time?



Press button 54 or ⏸55 briefly. The display shows, for 20 secs., the programmed starting time. This activates the timer to start the heater at the time shown.

7. Do you want to cancel a programmed start?



Press button 56 or ⏸57 briefly. The appropriate number in the display goes out, together with the yellow light.

PREVOST

XL Series Motorcoach

TABLE OF CONTENTS

| | | |
|--|--------------|--|
| FOREWORD | 1 - 1 | Engine compartment components2 - 34 |
| CONTROLS/INSTRUMENTS | 2 - 1 | Baggage compartment2 - 35 |
| Keys..... | 2 - 1 | Spare wheel & tire compartment2 - 35 |
| Main battery disconnect switch..... | 2 - 2 | A/C & heating and condenser compartment doors..... |
| Fuel tank filling..... | 2 - 2 | Service doors2 - 36 |
| Controls and instrument panels..... | 2 - 3 | L.H. side rear service compartment and main power compartment2 - 36 |
| L.H. side control panel..... | 2 - 4 | Battery compartment..... |
| Cruise control switches..... | 2 - 6 | Interior compartments..... |
| Dashboard (without tachograph)..... | 2 - 9 | Lavatory..... |
| Dashboard (with tachograph)..... | 2 - 10 | Parcel racks..... |
| Dashboard indicator/warning lights..... | 2 - 11 | Safety equipment compartment..... |
| L.H. lower switch panel..... | 2 - 15 | Accessories..... |
| R.H. lower switch panel..... | 2 - 16 | Preheating system timers (auxiliary)..... |
| R.H. console..... | 2 - 16 | |
| Detroit diesel PRODRIVER™ controls..... | 2 - 17 | SAFETY |
| R.H. lateral console..... | 2 - 20 | 3 - 1 |
| Automatic transmission..... | 2 - 21 | Brakes..... |
| Manual transmission..... | 2 - 23 | Antilock braking system (ABS)..... |
| Steering column controls..... | 2 - 24 | Air system emergency fill valve..... |
| Foot-operated controls..... | 2 - 25 | Back up alarm..... |
| Tilt steering wheel and telescopic steering column..... | 2 - 26 | Kneeling system..... |
| Entrance door..... | 2 - 26 | Hi-buoy system..... |
| Seats..... | 2 - 27 | Low-buoy system..... |
| Driver's seat..... | 2 - 28 | Emergency exits..... |
| Seat belts..... | 2 - 28 | Day time running lights..... |
| Passenger seats..... | 2 - 29 | Fog lights..... |
| Tour guide seat..... | 2 - 29 | Horns..... |
| Mirrors..... | 2 - 29 | Alarm system..... |
| Exterior compartments (XL-40)..... | 2 - 31 | Safety equipment..... |
| Exterior compartments (XL-45)..... | 2 - 32 | Safety precautions..... |
| Engine compartment doors..... | 2 - 33 | Defensive driving..... |
| Engine air intake ducts..... | 2 - 33 | |
| Fuel tank filling door..... | 2 - 33 | |
| Entrance door..... | 2 - 33 | |

PREVOST**XL Series Motorcoach
SAFETY**

(see items #14 & 19 on page 2-9)

BRAKES

There are two (2) brake systems on your vehicle, the service brakes and the combination emergency & parking brakes, both of which are described below.

Your vehicle may also be supplied with ABS brakes (antilock braking system) and an additional retardation system. ABS brakes system information is available in this section on page 3-2; for information regarding both optional retardation systems, see "ENGINE RETARDER SYSTEM (JACOB)" on page 4-4 and "AUTOMATIC TRANSMISSION OUTPUT RETARDER" on page 4-5.

Service brakes

The service brakes use air pressure from a footpedal-operated master cylinder to actuate cylinders which apply the brakes at each wheel. The air system is divided into two (2) independent circuits to isolate front brakes from rear brakes, thus providing safe braking if one (1) circuit fails. Front axle brakes operate from the secondary air system, while brakes on both the drive axle and tag axle operate from the primary air system.

NOTE: *The tag axle service brakes operate only when the axle is in normal ride position (loaded & down).*

Furthermore, the brake application sequence, which starts with rear brakes and then front brakes, provides uniform braking on slippery surfaces.

For safe brake effectiveness, vehicle air system pressure should reach at least 95 psi (655 kPa) in both primary and secondary air circuits.

A warning light turns on (see Dashboard items #7 & 8, page 2-9) and a buzzer sounds when airpressure in one of the primary or secondary circuits drops below 60 psi (413 kPa). Vehicle must then be stopped and cause of pressure loss must be corrected before further operation.

WARNING: *"FANNING" or "PUMPING" brake pedal is not recommended. This practice will not increase brake system effectiveness, but will instead waste air and thereby reduce brake effectiveness.*

"RIDING" the brake by resting foot on brake pedal when not braking can cause abnormally high brake temperatures, excessive lining wear, possible damage to the brake drums, and loss of brake efficiency.

Combination emergency and parking brakes**Emergency brakes**

In normal operation, if air pressure in both brake circuits drops below approximately 40 psi (276 kPa), spring-loaded emergency parking brakes will immediately be applied at full capacity on drive and tag axle wheels to stop vehicle (tag axle emergency brakes are optional on XL-40 vehicles). In an extreme condition, the emergency brakes might be applied quite rapidly. Vehicle must then be stopped and cause of pressure loss must be corrected before resuming operation.

Parking brakes

Spring-loaded parking brakes are manually applied by pulling up the control valve knob, located on R.H. lateral console (see page 2-20).

They are not designed to be used as service brakes. In normal driving conditions, control valve knob must be pushed all the way down.

NOTE: Parking brakes can supplement service brakes to stop the vehicle in an emergency condition only. The stopping distance will be considerably longer than with a normal brake application.

Before releasing parking brakes by pushing down control valve knob, pressure gauges should be checked to ensure that brake system air pressure has built up to a minimum of 95 psi (655 kPa).

WARNING: Always apply parking brake before leaving driver's seat.

NOTE: Each time the parking brake is applied and ignition key is turned or left to the "ON" position, the stoplights automatically light up.

ABS BRAKES (antilock braking system) (Optional)

The purpose of the antilock braking system is to preserve the stability and steerability of a vehicle during braking, and to minimize its stopping distance whatever the road conditions.

On slippery roads and in emergency situations, overbraking frequently induces wheel locking. Antilock braking system provides maximum braking performance while maintaining adequate steerability on slippery roads.

Also, on smooth or slippery surfaces, the stopping distance with locked wheels is greatly extended; on rough surfaces the problem is tire abrasion.

The basis of ABS is constant monitoring of the wheel behaviour during braking. Sensors on each wheel of front and drive axles continually monitor the wheel speed during braking, transmitting this information to a four-channel electronic processor which senses when a wheel is about to lock. Modulating valves quickly adjust the brake pressure (up to 5 times per second) to prevent wheel from locking. Each wheel is thereby controlled according to the grip available between its tire and the road.

In this way the vehicle is brought to a halt in the shortest possible time, while remaining stable and under driver's control.

CAUTION: On slippery roads, motorists behind you may not be able to brake as fast as you; so whenever possible, give a prior warning by lightly depressing brake pedal several times before braking.

AIR SYSTEM EMERGENCY FILL VALVE

The vehicle is equipped with two air system emergency fill valves to supplement the air system when air pressure is low and engine cannot be operated. The rear valve is located in engine compartment and is accessible from engine R.H. side door: On XL-40 vehicles, the valve is positioned next to battery booster block, close to door hinge; on XL-45 vehicles, the valve is positioned directly under back up alarm, close to L.H. side of door opening.

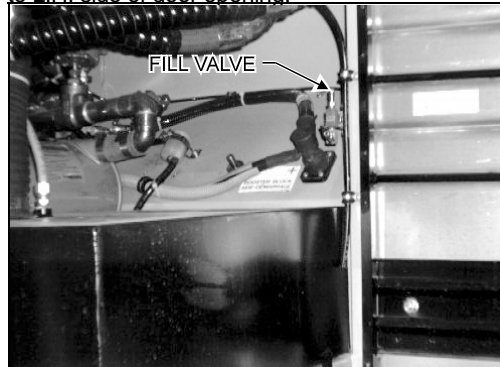

XL-40 rear valve location

12057

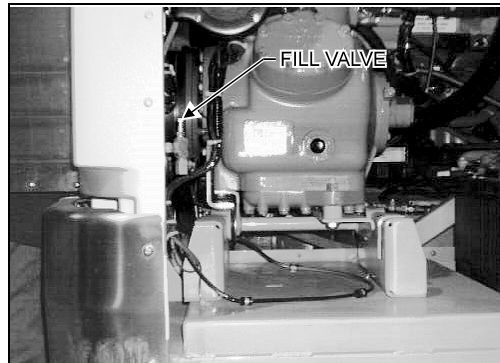

XL-45 rear valve location

12011

The front valve is located in the steering compartment close to R.H. side of door frame.

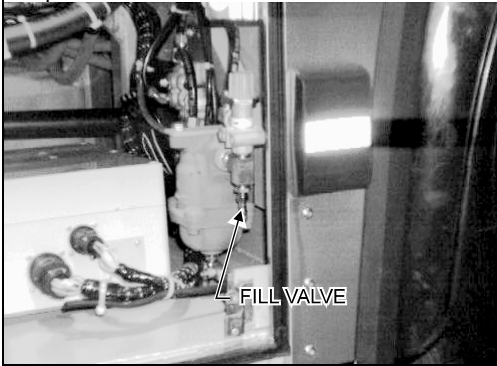

Front valve location

12012

These two air system emergency fill valves are fitted with the same valve stems as standard tires, and can be filled by any standard external air supply line.

The rear air system emergency fill valve will supply air for all systems (brakes, suspension and accessories) while the front fill valve will supply air for accessories only.

CAUTION: Air filled through these two points will pass through the standard air filtering system provided by Prévost. Do not fill air through any other points.

BACK UP ALARM

The back up alarm system serves to warn bystanders of vehicle moving in reverse range. Driver should take extra precautions when backing up. If in doubt, have someone guide you.

KNEELING SYSTEM

This system enables passengers to get on and off the coach without any difficulty by lowering the front end. The system operates rapidly; taking only 5 seconds to lower and 9 seconds to raise.

NOTE: This coach is equipped with an interlock system which will automatically apply the parking brake when the kneeling system is activated.

To operate, stop the coach, set the transmission to neutral(N), then push down the rocker switch located on the L.H. side control panel (Item #12 on page 2-4). The parking brake will be automatically applied and a warning flasher (item #1 on page 2-9) will indicate that the front of the coach is being lowered.

To raise the front of the coach to its normal height, push up the rocker switch. The front end will rapidly rise up. Release the parking brake, and shift transmission to the desired range.

CAUTION: Avoid parking the coach too close to the sidewalk or other obstacles that could damage the coach during kneeling operations.

NOTE: The kneeling system does not operate when the coach is travelling over 5 mph (8 km/h). Consequently, the driver cannot inadvertently operate the kneeling system at higher speeds.

HI-BUOY SYSTEM

The coach can be equipped with a front Hi-Buoy or full Hi-Buoy.

The front Hi-Buoy system has the same functions as front kneeling. It enables passengers to get on or off the coach easily by raising the front end about 4 inches (100 mm). The front Hi-Buoy is combined with front kneeling to increase flexibility of the system (See item #12 on page 2-4).

The full Hi-Buoy system raises both the front and rear sections of the coach about 4 inches (100 mm). It can be used to enable passengers to get on or off the coach easily, to safely travel roads with high obstacles and to board Ferry Boats etc. (see item #12 on page 2-4 and indicator light #1 on page 2-9).

NOTE: The Hi-Buoy system does not operate when the coach is travelling over 5 mph (8 km/h). Consequently, the driver cannot inadvertently operate the Hi-Buoy system at higher speed.

LOW-BUOY SYSTEM

This system lowers both the front and the rear sections of the coach about 4 inches (100 mm). It

enables the coach to drive through underpasses where the height is less than 130.7 " (3.3 m), the ground is level and your vehicle is equipped with standard tires.

Operation of the Low-Buoy is controlled by a valve (Item #4 on page 2-20) located on the R.H. lateral console. The valve can be switched to either LOW-BUOY or NORMAL positions. The coach will be lowered automatically. A warning light (item #1 on page 2-9) on the central dashboard will indicate that the coach is being lowered.

CAUTION: Avoid parking the coach too close to the sidewalk or other obstacles that could damage the coach during the operation of the low-buoy.

NOTE: The Low-Buoy system does not operate when the coach is travelling over 5 mph (8 km/h). Consequently, the driver cannot inadvertently operate the Low-Buoy system at higher speeds.

EMERGENCY EXITS

Side windows

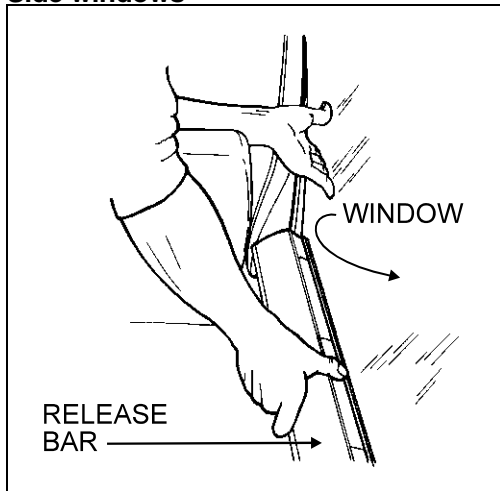

18122

Some side passenger windows can be opened from the inside for emergency escape purposes (XL-40 = 4 on driver side and 3 on curb side - XL-

45 = 4 on driver side and 4 on curb side). A decal indicating location of nearest emergency exit window is affixed at bottom of each side window. The upper section of each emergency side window is equipped with two blue lights that are activated by the exterior lighting switch located on R.H. lower switch panel (item #3 on page 2-16).

To open window, slide fingers under release bar, then push out bottom of window. Instruction decals are affixed to the release bar of each emergency exit window.

To close window, lift window release bar and pull window towards you.

CAUTION: All emergency exits should be kept closed during normal operation. Avoid slamming windows shut; this could damage emergency exit system.

Emergency opening of entrance door from the inside

In the event of a malfunction in the front entrance door air lock mechanism, press the door override button located on R.H. lateral console (see item #3 on page 2-20) to release mechanism, and complete the opening procedure by turning the entrance door opening handle counterclockwise.

Emergency roof escape

An emergency escape hatch is located in the roof at the rear of the coach, and is designed to be opened by passengers. An optional emergency roof hatch can also be installed at the front of the coach. In case of an emergency, fully push out ventilation hatch, then while depressing black tab towards rear of vehicle, push handle out in the same direction; this will release emergency hatch catch.

NOTE: These instructions are also affixed to escape hatch.

In the event of ventilation systems failure, hatch can be used to provide air circulation, by simply pushing hatch upwards.

CAUTION: If running with roof hatch(es) open, beware of low overhead clearances.

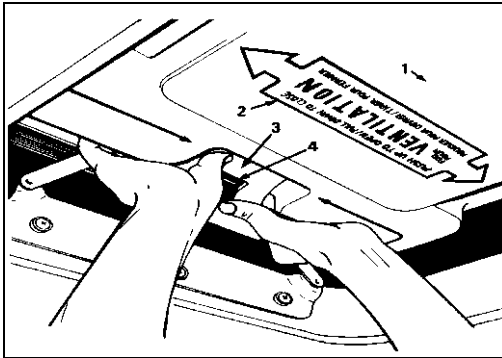

18051

- 1Emergency escape hatch
- 2Instructions decal
- 3Hatch handle
- 4Black tab

To relatch handle after use, push vent arms upright in "full open vent" position, then insert edge into bracket and pull handle in. Finally, pull hatch inward, one side at a time.

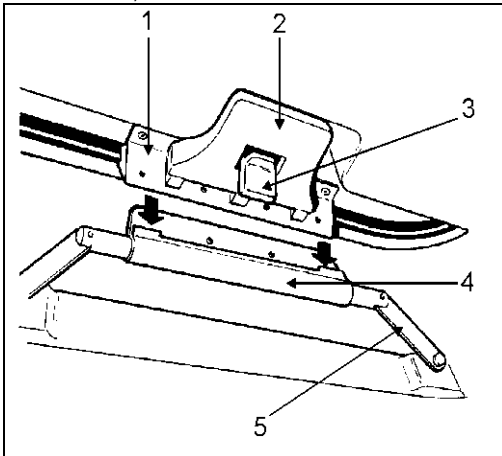

18052

- 1Edge
- 2Handle
- 3Black tab
- 4Bracket
- 5Vent arm

DAY TIME RUNNING LIGHTS

This system turns on automatically the low beams at a lower intensity as soon as engine is started and parking brake is released.

This system will be cancelled;

- when engine is stopped
- when parking brake is applied
- when the headlight switch is turned on.

WARNING: Never run vehicle at night with these lights only as they have a lesser intensity, and the system does not turn on the marker and clearance lights.

FOG LIGHTS (Optional)

The halogen fog lights recessed in front bumper allow the driver a better visibility in foggy weather, and improve the range of vision just ahead of vehicle. They are also a useful "active safety" factor. For location of ON/OFF switch, see page 2-16, item #2.

NOTE: Some States or Provinces may restrict the use of these lamps. Verify regulations governing each State and/or Province before using fog lights.

HORNS

Air horns

The air horns can only be used on highways. When the push-button valve located on the floor next to driver's left foot is activated, the valve releases air which sounds the horn.

Electric horns

Use the electric horns in cities and suburban areas. They are activated by simply pushing on button located in the center of steering wheel.

ALARM SYSTEM

As an added protection to indicator lights, Prévost vehicles are equipped with audible alarms to inform the driver of the following operating conditions:

| Indicator lights | Audible alarm | Condition |
|------------------|---------------|---|
| Air primary | Buzzer | Low air pressure |
| Air secondary | Buzzer | Low air pressure |
| "Do not shift" | Buzzer | Inhibits shifting of transmission |
| N/A | Buzzer | Lavatory emergency button is activated |
| N/A | Chime | Service button activated by passenger |
| Front kneeling | Beep | Front kneeling, low-buoy or high-buoy is selected (N/A from V.I.N. 2P9L33496S1001570) |
| Tag axle | Beep | Tag axle raised or unloaded |
| N/A | Bell ringing | Fire in engine compartment |

NOTE: The alarms for both primary and secondary low air pressure are produced by the same buzzer.

SAFETY EQUIPMENT

First aid kit

A first aid kit is supplied as standard equipment and is located in the Safety Equipment Compartment (see page 2-38).

Extinguishers

Two fire extinguishers are provided with the vehicle and are installed underneath the front L.H. side passenger seat. Use Fire Extinguishers as required, while carefully following instructions on Extinguishers' Labels. Learn how to operate fire extinguishers beforehand in case of an emergency.

Emergency warning reflectors

A kit of triangular reflectors (Qty=3) is provided to warn approaching motorists of an immobilized vehicle in a Breakdown Situation. This device indicates an Emergency Situation by reflecting the light emanating from a light source. The three reflectors should be placed as illustrated on inside face of box cover. This kit complies with FMVSS 125 (Federal Motor Vehicle Safety Standards).

The Kit is located inside Forward Baggage Compartment and can be removed by simply

unscrewing Wing Nut and removing Retaining Rod.

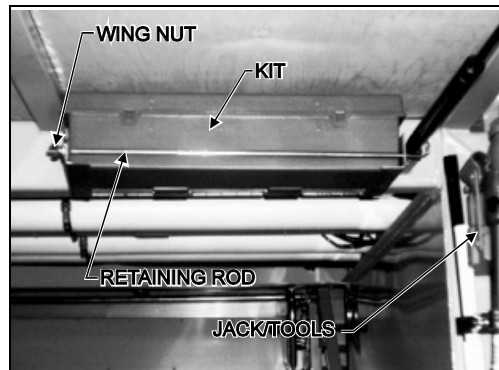

23010

Jack/Tools

A kit for jacking vehicle is stored inside Forward Baggage Compartment (See above figure). The kit includes a 12.5 ton hydraulic jack and a wheel nut wrench.

Fire hatchet (Optional)

The fire hatchet is stored within the Safety Equipment Compartment (see page 2-38).

SAFETY PRECAUTIONS

To ensure safe and reliable operation, take note of the following safety precautions:

- a)** Operation and maintenance of the coach must only be performed by qualified personnel.
- b)** Use caution when embarking and disembarking passengers.
- c)** Always pay attention to pedestrians passing in front and behind the coach. Always yield to pedestrians at pedestrian walkways.
- d)** Inspect the coach before operating (see "DAILY WALK-AROUND INSPECTION" on page 6-15).
- e)** Make sure good visibility is maintained at all times. Keep windshields clean and free of obstructions.
- f)** Make sure all doors are closed and secure before operating the coach. Before driving, conduct a walkaround inspection to check for security of all baggage compartment doors and equipment access doors.
- g)** Adjust the driver's seat so that all controls can be easily reached.
- h)** Always wear safety belt when driving.
- i)** Check the instrument panel frequently. Do not operate the coach when dials or indicators are not in the normal operating condition.
- j)** Switch from high beams to low beams when meeting or following other vehicles within 500 feet (150 meters).
- k)** Do not drive over obstacles on the road. Empty cartons, piles of leaves, and snowdrifts could conceal hidden dangers that could damage the coach suspension and/or underbody.
- l)** When turning or changing lanes, signal your intention well in advance.
- m)** When approaching to make a right turn, reduce spacing between coach and curb to make sure other vehicles cannot pass on the right. Since the coach makes wide turns, allow enough space to make safe turns.
- n)** Never leave the coach unattended with the engine running, or with the key in the ignition. Turn off the engine, remove keys and apply the parking brake before leaving the coach.
- o)** The service life of the coach depends on the kind of maintenance it receives. Always record any problems and report them immediately to maintenance personnel.
- p)** Shut-off engine before fueling, adding oil or performing maintenance or servicing tasks, unless stated otherwise.
- q)** Do not run the engine or HVAC system with access doors left open. Close compartment doors before operating any equipment.
- r)** Do not remove the surge tank filler cap or the cooling system pressure cap when the engine is hot. Let the engine cool down before removing filler caps.
- s)** Fuel is highly flammable and explosive. Do not smoke when refueling. Keep away from open flames or sparks.
- t)** Do not attempt to push or pull-start a coach equipped with an automatic transmission. To avoid damaging gears or bearings in manual transmission-equipped coaches, do not push, pull or roll-start in first or reverse gears.
- u)** For additional information about safe driving practices, contact the local department of motor vehicles authority.

DEFENSIVE DRIVING

- a)** To keep the coach from drifting across lanes during highway driving, always look over the horizon on the road ahead.
- b)** Don't stare at the road ahead. Keep your eyes moving. Check all mirrors and dashboard instruments frequently.
- c)** Establish eye-to-eye contact with other drivers and with pedestrians. Use headlights, high-beams and low-beams, turn signals and horn(s) as needed.
- d)** For city driving, allow a four to six second travel interval between the coach and the vehicle ahead. Increase this travel interval to six to eight seconds for highway driving. Use increased travel interval for night driving and in bad weather.
- e)** Adjust your speed according to the road conditions, traffic and visibility. Never exceed the posted speed limits.
- f)** Reduce your speed if another vehicle is following too close behind to let the vehicle pass.
- g)** Be prepared to stop when approaching an intersection. The stopping distance of the coach increases with the weight and speed of the coach.
- h)** For additional information about defensive driving practices, contact the local department of motor vehicles authority.

TABLE OF CONTENTS

STARTING AND STOPPING

PROCEDURES 4 - 1

| | |
|--|--------|
| General information..... | 4 - 1 |
| Detroit Diesel Electronic Control (DDEC)..... | 4 - 3 |
| World Transmission WT Electronic Control System..... | 4 - 4 |
| Manual transmission..... | 4 - 8 |
| Cold weather starting..... | 4 - 8 |
| Daily inspection..... | 4 - 9 |
| Recommendations..... | 4 - 10 |
| Heating and air conditioning..... | 4 - 11 |
| Preheating systems..... | 4 - 14 |
| Windshield washer reservoir..... | 4 - 15 |
| Jump starting..... | 4 - 16 |
| Electric circuit protection..... | 4 - 17 |
| Tires..... | 4 - 18 |
| Towing..... | 4 - 20 |
| Jacking points..... | 4 - 21 |
| Retractable tag axle..... | 4 - 21 |
| Tag axle unloaded..... | 4 - 21 |

TECHNICAL INFORMATION 5 - 1

| | |
|------------------------|-------|
| Dimensions..... | 5 - 1 |
| Weights..... | 5 - 2 |
| Capacities..... | 5 - 2 |
| Fuel type..... | 5 - 2 |
| Wheels and tires..... | 5 - 2 |
| Belts..... | 5 - 3 |
| Engines..... | 5 - 3 |
| Transmissions..... | 5 - 3 |
| Drive axle ratio..... | 5 - 3 |
| Brakes..... | 5 - 4 |
| Steering..... | 5 - 4 |
| Electrical system..... | 5 - 4 |
| Sound system..... | 5 - 4 |
| Video system..... | 5 - 4 |
| Suspension..... | 5 - 4 |

| | |
|---|--------|
| Alignment..... | 5 - 5 |
| Heating and air conditioning..... | 5 - 5 |
| Oil specifications..... | 5 - 5 |
| Antilock braking system (ABS)..... | 5 - 6 |
| Preheating systems..... | 5 - 6 |
| Storage volume..... | 5 - 6 |
| Seats..... | 5 - 7 |
| DDEC III diagnostic codes..... | 5 - 7 |
| World transmission WT diagnostic codes..... | 5 - 10 |
| Light bulb data..... | 5 - 25 |
| Data plate and certification..... | 5 - 27 |

CARE AND MAINTENANCE 6 - 1

| | |
|---|--------|
| Interior cleaning..... | 6 - 1 |
| Exterior cleaning..... | 6 - 3 |
| Oil verification..... | 6 - 4 |
| Air tanks..... | 6 - 7 |
| Coolant level verification..... | 6 - 8 |
| Water separator..... | 6 - 8 |
| Belt tensioners..... | 6 - 8 |
| A/C and heating air filters..... | 6 - 10 |
| Flexible hose maintenance..... | 6 - 10 |
| Lubrication..... | 6 - 11 |
| Fire extinguishers..... | 6 - 11 |
| 110-120 volt in-station lighting..... | 6 - 11 |
| 110-120 volt in-station connectors..... | 6 - 11 |
| Back-up camera..... | 6 - 12 |
| Filter restriction indicator..... | 6 - 12 |
| Lavatory maintenance..... | 6 - 12 |
| First service on new vehicle..... | 6 - 14 |
| Lubrication and servicing schedule..... | 6 - 15 |

SERVICE LITERATURE 7 - 1

PREVOST

XL Series Motorcoach STARTING AND STOPPING PROCEDURES

GENERAL INFORMATION

CAUTION: Read this section of manual before driving vehicle.

Starting engine from driver's compartment

The following procedure is used to start and stop the engine from the driver's compartment.

Starting engine

1. Make sure the starter selector switch in engine compartment is set to the "NORMAL" position and that main battery disconnect switch (see page 2-2) is set to the "ON" position.
2. Make sure the parking brake control valve knob, located on R.H. lateral console, is pulled all the way up, so that the spring-loaded parking brakes are applied.
3. Make sure transmission is in neutral.
4. Turn ignition key to "START" position, then release it as soon as engine starts.

NOTE: If engine does not start, ignition key must be returned to the "OFF" position prior to restarting.

CAUTION: Special precautions are necessary with turbocharged engines to avoid possible turbine damage. After starting, run the engine at low idle for two minutes to allow flowing of lubricant to the turbocharger. Afterwards, run at fast idle and check oil pressure before attempting to drive the vehicle.

Do not engage starter for more than 15 seconds at a time. If engine does not start within 15 seconds, release ignition key and allow starter to cool for one (1) minute before engaging starter again. Continuous use of the starter without allowing a cooling period may damage the starter motor.

With DDEC engines, pressure must not be applied on accelerator pedal before starting. An application on pedal will induce a fault information to the Electronic Control Unit, thus affecting the fuel system control.

If accelerator pedal is depressed inadvertently, release it and wait approximately 30 seconds before resuming starting procedure.

Stopping engine

1. Apply parking brake then set transmission to the neutral position.
2. Allow engine to run at slow idle for at least two minutes, then shut off engine. This will ensure that the turbine speed has dropped, and the engine exhaust gas temperature is down to approximately 300°F. If engine is equipped with pyrometers, temperature can be observed.

CAUTION: Do not shut the engine down directly from high rpm.

If vehicle is parked and left unattended for an extended period of time, main battery disconnect switch (see page 2-2) should be set to the "OFF" position.

STARTING AND STOPPING PROCEDURES

Starting engine from engine compartment

The following procedure is used to start and stop the engine from the engine compartment.

Starting engine

Switches for starting and stopping the engine from the engine compartment are mounted on the R.H. side of rear junction box.

WARNING: Before attempting to start engine from engine compartment, make sure parking brake is applied and transmission is in neutral.

1. Make sure the starter selector switch in engine compartment is set to the "REAR START" position and the main battery disconnect switch (see page 2-2) is set to the "ON" position.

2. Press starter push button switch and release as soon as engine starts.

WARNING: Stay away from moving parts, and do not wear loose clothes (no neckties, open jackets, shirttails, etc.).

CAUTION: Steps previously explained with respect to starter use also apply in this situation.

Stopping engine

Stop only by turning the starter selector switch to the "OFF" position.

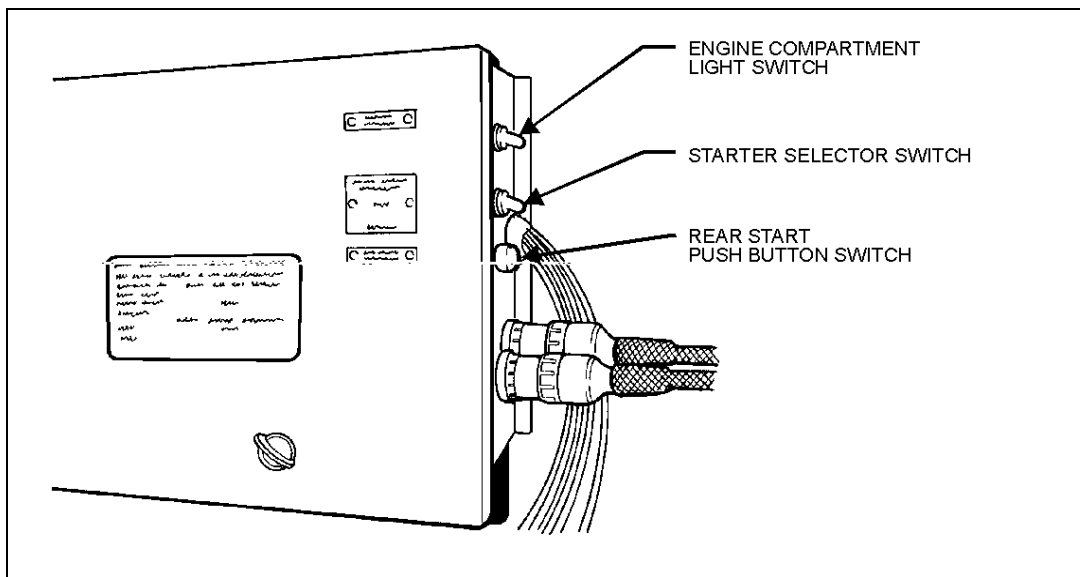

01017

DETROIT DIESEL ELECTRONIC CONTROL (DDEC)

The major components of DDEC are as follows:

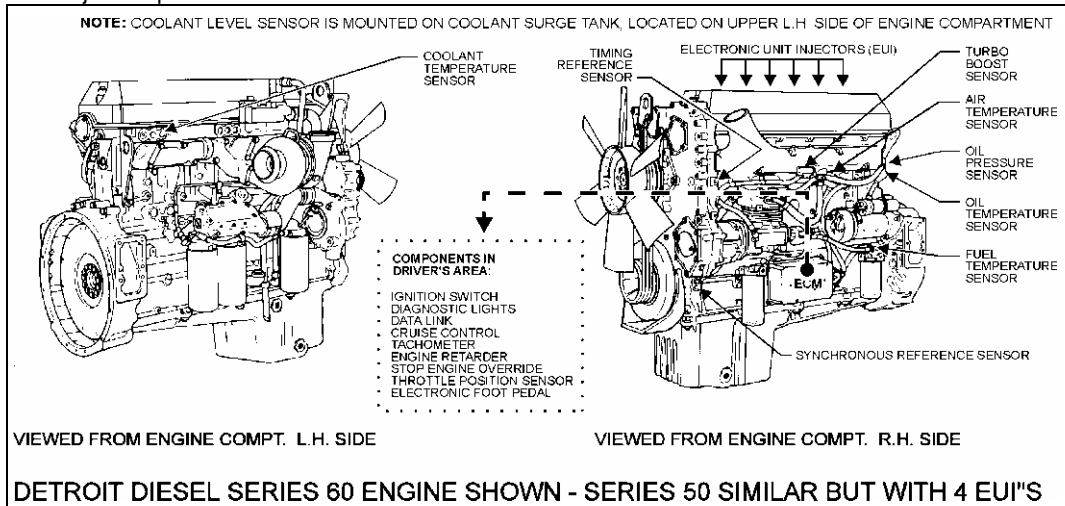

01015

DDEC is an advanced technology electronic fuel injection and control system for Detroit Diesel engines. As an integral part of the engine, the DDEC system provides a number of performance features and driver benefits, including improved fuel economy and performance, reduced cold smoke, reduced maintenance and repair cost. These advantages are obtained by optimizing control of the critical engine functions which affect fuel economy, engine reliability and the performance of the injectors.

Its major components include an Electronic Control Module (ECM), Electronic Unit Injectors (EUI) and sensors. The ECM is the brain of the DDEC system and is located over the engine between both cylinder heads. Within the ECM is the Electrically Erasable, Programmable, Read Only Memory (EEPROM) that provides instructions for basic engine control functions such as rated speed and power, engine governing, cold start logic and diagnostics, plus an engine protection system.

The ECM continuously monitors and analyzes the DDEC system during engine operation with electronic sensors. The Electronic Unit Injectors (EUI) operate a similar principle to the mechanical unit injector system. However, a solenoid-operated control valve performs the injection timing and metering functions which make injector timing much simpler and more precise.

DDEC provides the capability to quickly diagnose system malfunctions by a self-diagnostic system; the self-diagnostic system monitors all engine sensors and electronic components and recognizes system faults and other engine-related problems by providing the technician with a diagnostic code. Diagnostic codes are logged into the ECM memory and can be read by performing procedure outlined on page 5-7.

ENGINE RETARDER SYSTEM (JACOBS)

The "Jacobs brake" is a diesel engine retarder that uses the engine itself to aid in slowing and

STARTING AND STOPPING PROCEDURES

controlling the vehicle. When activated, the "Jacobs brake" alters the operation of the engine's exhaust valves so that the engine works as a power-absorbing air compressor. This provides a retarding action to the wheels.

The engine brake is a vehicle-slowng device, not a vehicle-stopping device. It is not a substitute for the service braking system. The vehicle's service brakes must be used to bring the vehicle to a complete stop.

Effectiveness of the engine brake system will vary according to transmission gear in use. The engine brake system is more effective in lower gears and at higher engine speeds.

WARNING: *When descending significant grades, use service brakes as little as possible. If engine does not slow vehicle to a safe speed, apply service brakes and shift to a lower gear. Let the engine (and engine brake) retard the vehicle. Keep brakes cool and ready for emergency stopping.*

NOTE: *Engine brake is operative only when accelerator pedal is released, and when engine speed is over 900 rpm.*

Each time the engine brake system is in operation, the stoplights will automatically light up.

WORLD TRANSMISSION WT ELECTRONIC CONTROL SYSTEM

The WT Electronic Control System consists of five (5) major components connected by wiring harnesses - Electronic Control Unit (ECU), engine throttle position sensor (or direct electronic communication), three (3) speed sensors, pushbutton shifter, and control module (which contains solenoid valves and a pressure switch). The throttle position sensor, speed sensors pressure switch, and pushbutton shifter transmit information to the ECU. The ECU processes this information and sends signals to actuate specific solenoids located on the control module in the

transmission. These solenoids control both the oncoming and offgoing clutch pressure during a shift.

Another feature of the World Transmission is its ability to adapt or "learn" as it operates. Each shift is electronically measured, stored and used by the ECU to adapt and "learn" the optimum conditions for future clutch apply and release. It is important to note that if the shift quality of low mileage vehicles or vehicles with new or recalibrated ECU's is unacceptable, simply drive the vehicle through its shift ranges for awhile. After this "learning" period any rough shifting will be corrected and shift quality will be restored.

In addition to controlling the operation of the transmission, the ECU monitors the system for conditions that could result in damage to the transmission or improper vehicle operation. When one of these conditions is detected, the ECU is programmed to respond automatically in a manner which will ensure safe operation of the vehicle and the transmission.

Torque converter

The torque converter consists of three (3) elements - pump, turbine, and stator. The pump is the input element and is driven directly by the engine. The turbine is the output element and is hydraulically driven by the pump. The stator is the reaction (torque multiplying) element. When the pump turns faster than the turbine, the torque converter is multiplying torque. When the turbine approaches the speed of the pump, the stator starts to rotate with the pump and turbine. When this occurs, torque multiplication stops and the torque converter functions as a fluid coupling.

The lockup clutch is located inside the torque converter and consists of three (3) elements - piston, clutch plate/damper, and backplate. The piston and backplate are driven by the engine. The clutch plate/damper, located between the piston and backplate, is splined to the converter turbine. The lockup clutch is engaged and released in response to electronic signals from the ECU. Engagement of the lockup clutch provides a direct

STARTING AND STOPPING PROCEDURES

drive from the engine to the transmission gearing. This eliminates converter slippage to provide maximum fuel economy. The torsional damper absorbs engine torsional vibration.

The lockup clutch releases at lower speeds and when ECU detects conditions requiring it to be released.

Planetary gears and clutches

A series of three (3) helical planetary gear sets and shafts provides the gear ratios and direction of travel for the vehicle. The planetary gear sets are controlled by five (5) multiplate clutches that work in pairs to produce six (6) speeds. The clutches are applied and released hydraulically in response to electronic signals from the ECU to the appropriate combination of solenoids.

Cooler circuit

The transmission oil is cooled by a remote-mounted oil cooler. Connections to the cooling circuit are located at the rear of the transmission to facilitate installation of remote cooler lines. Oil ports are internal requiring only coolant to be routed to and from the cooler.

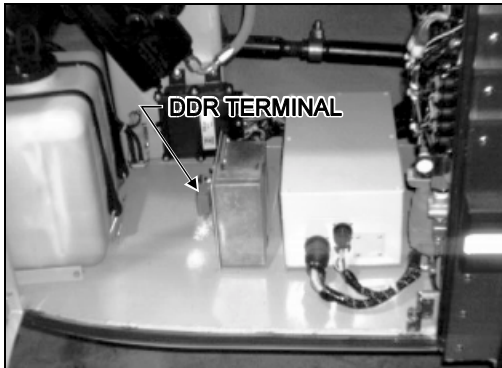

Steering Compartment

07005

To enhance troubleshooting and to allow interrogation of the ECU for valuable service information, a DDR (diagnostic data reader) can be used. To use it, plug the appropriate connector (not furnished by the manufacturer) in the terminal located in the steering compartment or the DDR connector located on L.H. side control

panel. You can also use your pushbutton shifter to perform certain maintenance operations (see page 4-6 under "Diagnostic codes").

Output retarder (Optional)

The purpose of the retarder is to assist in stopping the vehicle during stop and go driving and to control the downhill speed of the vehicle on a grade. For both of these uses, the retarder serves to extend the life of the service brakes and to enhance vehicle control.

The retarder system is activated by turning "ON" the retarder enable switch (L.H. side control panel-item #4 on page 2-4).

The retarder controls are broken down into two (2) types:

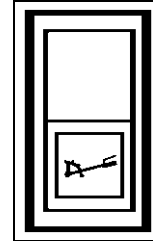

18017

BRAKE APPLY - actuated by brake pressure; applies the retarder at three (3) distinct retardation levels (low = 1/3 - 2 psi, medium = 2/3 - 4 psi, and "full on" - 7 psi) when increasing pressures are detected in the brake system.

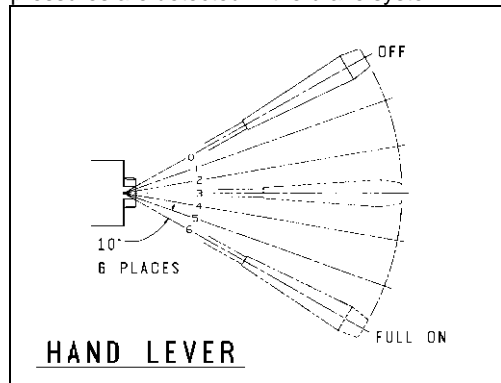

18018

AUTOMATIC APPLY - actuated by hand lever located on R.H. side of steering column; retarder capacity is determined by hand lever which permits the operator to select "OFF", or one of six (6) levels of automatically-commanded retardation, the highest of which is maximum retarder capacity "full on".

STARTING AND STOPPING PROCEDURES

The controls may be used in combinations such that the retarder can be activated when either of the two (2) controls are actuated. (If both are actuated simultaneously, the level of retardation will correspond to higher input signal).

The optimum retarder control will depend on the vehicle type and retarder use. In general maximum brake savings occur with increased retarder use. In stop and go driving, retarder use can be maximized by using the "BRAKE APPLY". For downhill speed control, the "AUTOMATIC APPLY" may provide the best operator control.

When the vehicle is equipped with the anti-lock braking system (ABS) and the system is activated, the transmission controls "ABS input" is used to disengage the retarder and the transmission lockup clutch, thus enhancing performance of the ABS system.

Diagnostic telltales

Two (2) diagnostic features are available with the transmission control system to assist in troubleshooting of malfunctions and/or the monitoring of specific operating parameters. These features include a "DO NOT SHIFT" light on the dashboard, and the Diagnostic Data Reader (DDR). When a malfunction is detected in the control system, a series of "diagnostic codes" are used to identify and clarify the nature of the malfunction.

Do not shift - light

The "DO NOT SHIFT" light is located on dashboard.

Illumination of this light, accompanied by eight (8) seconds of short beeps from the shifter, indicates that shifts are being restricted. The *SELECT* digit on the display will be blank. Operation may continue in order to reach service assistance. The ECU may not respond to shifter requests, since operating limitations are being placed on the transmission,



i.e. upshifts and downshifts may be restricted. Direction changes will not occur. The ECU will not respond to operator requests while *DO NOT SHIFT* is indicated.

Any time this light has been illuminated, the ECU will register a diagnostic code. It may be identified on the digital display and/or the Diagnostic Data Reader (DDR).

Diagnostic Data Reader (DDR) (Optional)

The purpose of the DDR is to assist in the installation checkout and the troubleshooting of malfunctions as detected by the ECU. The DDR is a portable microcomputerbased receiver/transmitter/display unit. The DDR transmits and receives data to/from the ECU, processes the data and displays appropriate information to the servicer. Operating instructions are supplied with each DDR.

Diagnostic codes

Illumination of the *DO NOT SHIFT* light during vehicle operation (start-up), indicates that the ECU has registered a diagnostic code. A summary of diagnostic codes with each associated transmission response is shown on pages 5-10 through 5-24.

Diagnostic codes can be displayed either by the DDR or on the digital display of the shifter. The following information describes use of the diagnostic capabilities of the system without the DDR.

Up to five (5) diagnostic codes can be registered in the ECU at one time. In addition to the code itself, additional information for each code is available: whether or not any inhibits resulting from the code are active; ignition cycle counts to indicate the frequency of the code occurrence. After a fixed number of ignition cycles, any code will automatically disappear from memory if it has not reoccurred.

The general procedure to display the codes is to first enter the diagnostic mode. This is

STARTING AND STOPPING PROCEDURES

accomplished by pressing the upshift and downshift arrow buttons simultaneously on the pushbutton shifter. Diagnostic mode will be entered only with the vehicle stopped. (The transmission should be shifted to *NEUTRAL* and the vehicle parking brake applied.) For each code stored in memory, beginning with any code that is presently inhibiting the transmission, the four (4) digits of the code and the pertinent parameters are continuously flashed on the display. Pressing the mode button once will cause the next code with pertinent information to be displayed. Dashes indicate all stored codes have been displayed.

To clear any active inhibits, the mode button must be depressed and held for an extended length of time. To clear the code from memory, The mode button must be pressed and held for a longer period of time. All active inhibits will also be cleared during a normal powerdown (ignition switched off followed by zero output and zero engine speeds).

Importance of proper oil level

1. Maintaining the proper oil level is very important. The transmission oil is used to apply clutches and to lubricate and cool the components. If the oil level is too low, the result can be poor performance because clutches will not receive adequate oil supply. If the oil level is too high, overheating results from the oil being churned and aerated.
2. Always check the oil level at least twice to ensure that an accurate check is obtained.
3. Transmission input speed and oil temperature significantly affect the oil level. An increase in input speed lowers the oil level; an increase in oil temperature raises the oil level. Thus, the oil level must always be checked with the engine running at idle (approximately 500 rpm), the parking brake applied, and the transmission in neutral. A final check of the oil level must be made when the transmission reaches normal operating temperature (160 - 250°F; 70 - 120°C).

Fill pipe protection

When adding oil or checking oil level, dirt or foreign material must not be allowed to enter the filler tube. Before removing the dipstick, clean around the end of the filler tube. Refer to "*Care & maintenance*" section for manual oil level check procedure.

Readout of the oil level sensor

The oil level sensor (OLS) is designed to measure transmission oil level only when a specific combination of operating conditions exist:

- engine must be at idle
- **NEUTRAL** must be selected
- zero output speed
- transmission oil must be within a "normal" temperature band
- once the first four (4) conditions are met, a "waiting" period must pass (approx. 2 min., to facilitate consistent oil drainback) before oil level measurement may begin.

To enter OLS readout mode (after meeting the conditions noted above), simultaneously press the *UPSHIFT* and *DOWNSHIFT* arrows on the shifter. If the five (5) conditions noted above are present, the display will immediately enter the reading mode. If the "waiting" period has not elapsed, the left digit of the display will become a "chasing" digit and the right digit will count down from (8) to (1) until the waiting period is complete.

After attaining the reading mode, the display will flash "*OL-OK*", "*LO-01*", "*HI-02*", etc., where the suffix "*01*" or "*02*" indicate the volume of oil (in quarts) low or high.

At any time in this sequence, simultaneously pressing the **UPSHIFT** and **DOWNSHIFT** arrows directs the ECU to enter the transmission diagnostic mode as described under "*Diagnostic Codes*" on page 4-6. D, N, or R may also be selected on the shifter at any time - the OLS mode will abort and normal transmission will commence. Shifts are not inhibited.

STARTING AND STOPPING PROCEDURES

Oil level sensor (OLS) codes

| <u>CODE</u> | <u>CAUSE OF CODE</u> |
|-------------|-------------------------------|
| OL-OK | oil level is correct |
| LO-01 | one quart low |
| LO-02 | two quarts low |
| HI-01 | one quart high |
| HI-02 | two quarts high |
| OL-50 | engine speed (rpm) too low |
| OL-59 | engine speed (rpm) too high |
| OL-65 | neutral must be selected |
| OL-70 | sump oil temperature too low |
| OL-79 | sump oil temperature too high |
| OL-89 | output shaft rotation |
| OL-95 | sensor failure |

MANUAL TRANSMISSION

Do not overfill the transmission. Overfilling usually results in oil breakdown due to excessive heat and aeration from the churning action of the gears. Early breakdown of the oil will result in heavy varnish and sludge deposits that plug up oil ports and build up on splines and bearings. Overflow of oil escapes onto clutch or parking brakes causing additional trouble. However, if oil level is too low, gears will be insufficiently lubricated.

CAUTION: Do not tow vehicles equipped with manual transmissions without first pulling the axles or disconnecting the drive shaft. Lubrication of the internal gear train is inadequate when the vehicle is towed.

COLD WEATHER STARTING

Cold starting aid (Ether) (Optional)

The vehicle may be equipped with an electrically-operated ether cold starting aid designed to ease engine starting when temperature is below 35°F (2°C). The control rocker switch, located on the L.H. lower switch panel (see page 2-15), is provided with a locking mechanism to avoid accidental use when engine is running. To activate the ether starting aid, proceed as follows:

1. Prior to cranking engine, slide down lock tab while pressing rocker switch for three (3) seconds to fill solenoid valve.

2. Release switch to discharge shot.

3. Allow three (3) seconds for shot to discharge.

4. Start engine, use additional shots if necessary to keep engine running.

CAUTION: This practice should be performed only when absolutely necessary. Excessive use of fluid could result in serious engine damage.

Engine block heater

The vehicle is equipped with an engine immersion-type electric block heater to assist cold weather starting. The heater male electric plug is easily accessible through the engine oil reserve tank access door. To use it, connect the female plug of an electrical extension cord to the heater plug. Some converted vehicles may have the heater connected to the coach AC power system. The extension cord must be plugged into a 110-120 V AC power source only. The engine block heater should be used whenever the vehicle is parked for an extended period of time in cold weather and a suitable power source is available.

CAUTION: Use only a 110-120 V AC power source. Extension cord must be of the grounded type (three prongs) and have a minimum rated capacity of 15 amps. Be sure to disconnect cord before starting and/or moving the vehicle.

Engine warm-up

After starting the engine, run it at low idle for two (2) minutes to allow flowing of lubricant to the turbocharger, then increase speed to fast idle for warm-up period by using "FAST IDLE" switch

STARTING AND STOPPING PROCEDURES

located on L.H. lower switch panel (see page 2-15). Run the engine at fast idle and no load for about five (5) minutes to allow it to warm-up before applying a load. Parking brakes should be kept applied throughout warm-up. Gauges and indicator lights should be monitored to check that all conditions are normal. If an abnormal condition should develop, stop engine immediately and have condition corrected.

WARNING: *Never let the engine run in an enclosed, non-ventilated area. Exhaust fumes from the engine contain dangerous gases which can be fatal if inhaled.*

NOTE: *The engine will come up to normal operating temperature shortly after you start driving; if possible, avoid going to full throttle until engine coolant temperature reaches 140°F (60°C).*

Transmission warm-up

When temperature is below -20°F (-29°C), the "DO NOT SHIFT" and "CHECK TRANS" will stay "ON" after the engine is started. The transmission will stay in neutral, regardless of the gear range selected until it warms past -20°F (-29°C). At that point, the "DO NOT SHIFT" light will turn off and the transmission will operate only in first gear or reverse. When the "CHECK TRANS" light goes out at 20°F (-7°C), the transmission is warm enough to safely operate in all gear ranges.

DAILY INSPECTION

With engine stopped

General

Check general vehicle condition and verify all exterior lighting. Also check for loose nuts and bolts.

Extinguishers

Ensure that fire extinguishers are in working order and easily accessible.

Emergency exits

Check that emergency exits can be easily opened.

Driver's area

Adjust mirrors and seat.

Doors

Make sure that all exterior doors and windows are closed.

Tools and spares

Check for wheel nut wrench and jack, door keys, spare belts and emergency reflectors.

Washer reservoir

Check that it is full. To prevent the windshield washer fluid from freezing during the winter, use antifreeze windshield washer.

Tires

All tires, including the spare, should be inspected for cuts and correct inflation. On both aluminum alloy and steel wheels, nuts should be checked using a torque wrench. Torque to 450-500 lbf•ft (610-680 N•m).

Wheel bearings

Check oil level in sight glass (see page 6-6).

CAUTION: *During a fuel stop, especially if a brake job has been performed recently, apply hand on wheel bearing cover and check for overheating.*

Leaks

Check thoroughly under vehicle and in compartments. Report all leaks to maintenance personnel.

STARTING AND STOPPING PROCEDURES

Coolant level

The cooling system is completely filled when the coolant (cold) is visible in the sight glass on the right side of the surge tank. If topping-up is necessary, fill the system with the same mixture ratio already used (50-50), as instructed in the "Maintenance Manual".

WARNING: Hot engine coolant is under pressure. Never remove cap until coolant has cooled.

Engine oil

Check oil level; refill directly into engine or from reserve tank (see page 6-4).

Air system

Purge accessories and wet tanks by opening drain valve (see page 6-7).

Power steering oil tank

Check oil level (see page 6-6).

Belts

Check for worn belts.

Belt tensioners

Visually check belt tension and the space between tensioning bellows' brackets (see page 6-8).

Seats

Make sure all seats and seat cushions are firmly attached.

Lavatory

Inspect for cleanliness and paper, towels & water supply.

With engine running

NOTE: Vehicle must be on level ground.

Gauges and buzzers

Gauges should be in normal position, warning lights and buzzers off.

Fuel level

Be sure level is sufficient.

Transmission

Check oil level (see page 6-4).

Leaks

Inspect around vehicle and listen for any air leak.

Water separator

Purge drain valve (see page 6-8).

Turbocharger

Look for any leaks or unusual sounds coming from the turbo compressor.

Service brakes

Check for pressure build-up. With engine stopped and no brake applied, loss should not exceed 3 psi/min. (21 kPa/min). Make a full brake application; loss should not exceed 7 psi (48 kPa).

Parking and emergency brakes

With air pressure above 65 psi (448 kPa), lower pressure with brake pedal applications, check that buzzer works and that control button lifts up. Wait until air pressure exceeds 95 psi (655 kPa) before releasing parking brakes.

RECOMMENDATIONS

- Make sure the basic principles of operation of the vehicle are understood.
- Maintain the vehicle in good running condition.

- Do not drive your vehicle with an extremely low fuel level. This advice is very important, especially if your vehicle is equipped with an auxiliary fuel tank. Unlike a gasoline engine, if a diesel engine runs out of fuel it will not simply restart after fuel is added to the tank. The engine must be "primed" (see procedure in the Maintenance Manual).

- Allow engine to run at slow idle for at least 2 minutes before turning it off.

- Engine should always be at idle speed when shifting from neutral to reverse or forward range.

- Automatic transmission shift pattern does not include a park position. Parking brake must therefore be applied to hold vehicle when it is unattended. Gearshift should then be in neutral position. If engine is stopped without applying the parking brake, a warning buzzer will sound until the parking brake is applied and your foot is removed from the brake pedal.

- Perform procedures as detailed in this manual.

- Unless otherwise specified, engine should be turned off for all lubrication and maintenance procedures.

- Do not attempt to push-start or pull-start the vehicle.

- Do not tow vehicle without first removing the drive axle shafts or disconnecting the drive shaft. Internal lubrication of the transmission is inadequate when the vehicle is towed.

- Fire extinguishers are stored underneath the front L.H. passenger seat. In case of fire, get everyone out of the vehicle, then think of your own safety before attempting to fight the fire.

- When driving on ice or snow, accelerations or decelerations should be done gradually.

NOTE: Normal operation as well as some emergencies or abnormal conditions are covered in this booklet. Any malfunction interfering with satisfactory operation should be corrected immediately, particularly when safety may be involved.

HEATING AND AIR CONDITIONING

Ventilation

Driver should always try to introduce as much circulation of outside fresh air as possible without hampering heating and air conditioning systems. Under extreme temperature conditions however, when maximum capacity is required, the adjustable intake dampers (see following pages) should be closed.

It should be remembered that the inside of vehicle should always be slightly pressurized to minimize the entrance of dust and moisture.

Vehicle heating and air conditioning systems have been designed to allow circulation of some outside fresh air, so windows should be kept closed at all times.

In case of air conditioning system failure, substitute ventilation may be provided by opening roof-mounted emergency vent(s).

NOTE: The driver's area A/C & heating and defrost systems are independant from the central system.

Central A/C & heating system

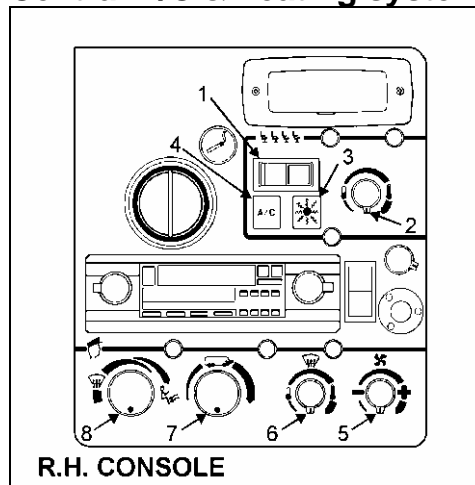

18123

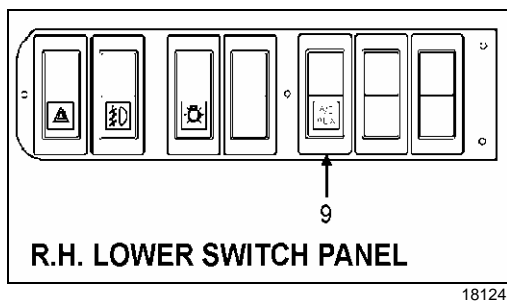

1. "A/C heat" switch

This switch has three positions: "A/C - OFF - HEAT". Set the switch to:

- "A/C" position (L.H. side) when vehicle's interior needs to be cooled or dehumidified.
- "HEAT" position (R.H. side) when vehicle's interior needs to be warmed or ventilated.
- "OFF" position (center) before stopping the vehicle.

NOTE: Fuel economy is slightly reduced when "A/C" position is used.

To operate air conditioning system when vehicle is stationary, run engine at fast idle. During operation of air conditioning system, windows should be kept closed and door not left open longer than necessary.

In order to prevent battery discharge, A/C & heating system will not operate if battery charging system is not working properly.

CAUTION: "A/C" position should not be used when outside temperature is below 40°F (5°C).

While the A/C system is running, make sure the vehicle is parked at least four (4) feet (1,2m) from other vehicles and/or buildings to allow a sufficient air flow through the condenser core.

2. "Temperature" control

Once the A/C clutch switch is set to the proper position and fans are on, select the desired temperature by turning the temperature control knob clockwise to raise or counterclockwise to lower temperature. Only a slight movement of knob is generally sufficient to change temperature setting.

Temperature control knob is used to select interior temperature within the range of 65 to 78°F (18 to 26° C). Once temperature is selected, system will automatically maintain it within close limits.

At extreme clockwise position, full heat will be maintained.

3. "Heat" indicator light

This indicator will be illuminated when hot water is circulating through the water valve, no matter which mode has been selected (A/C or heating).

4. "A/C" warning light

This light is designed to light up when the "A/C" system is not working properly. If this happens, first stop "A/C" system, then perform the following checks:

- Check the condenser for obstruction. Clean if necessary. (Refer to "Maintenance Manual").
- Check that the evaporator and condenser motors are operating.
- Check evaporator filter for cleanliness. Clean or replace as required. (Refer to "Care and Maintenance" section, page 6-9).
- Check the air return duct(s) for obstruction. Ducts are located on the left side or on both sides of the vehicle floor, approximately in the center. Clean if necessary.

After these checks, test the system. If the "A/C" warning light does not turn off, set the "A/C - heat" switch to "OFF" position, and seek qualified service assistance.

Driver's compartment A/C & heating system

5. "Fan" speed control

Turn knob clockwise at the first position to obtain minimum air flow and to start "Driver's system" to circulate warm, cool, or outside air, according to settings of temperature control knob (driver's), "A/C-heat" switch and "Recirc.-fresh air" control. Turn clockwise again to obtain the desired ventilation speed.

6. "Temperature" control

Once the A/C clutch switch is set to the proper position and fans are on, select the desired temperature by turning the temperature control knob clockwise to raise or counterclockwise to lower temperature. Only a slight movement of knob is generally sufficient to change temperature setting.

Temperature control knob is used to select interior temperature within the range of 65 to 78°F (18 to 26° C). Once temperature is selected, system will automatically maintain it within close limits.

At extreme clockwise position, full heat will be maintained.

WARNING: Excessive high temperature in driver's area could induce drowsiness, affecting driver's ability to operate the coach safely.

NOTE: Driver's air conditioning system will only operate simultaneously with main air conditioning system, but heating and defrost systems are independant from main system.

Driver's A/C & heating system also affects the two (2) front rows of passenger seats, and should be used in concert with main system, not in opposition.

7. "Recirc.-fresh air" control

This knob should normally be rotated clockwise to allow maximum fresh air admission. When outside temperature is extremely high and maximum cooling is required or when outside temperature is extremely low and maximum heating is required, the knob should be rotated counterclockwise to shut off the fresh air admission, thus recirculating the air inside vehicle. This position should also be selected when driving vehicle on dusty roads and in air polluted areas to avoid admission of contaminated air inside vehicle.

WARNING: Keep in mind that the "Recirc.-fresh air" control must be reset to the "fresh air" position following these special road conditions in order to prevent contamination of air in driver's area.

NOTE: In order to improve air circulation when A/C system is inoperative, open the roof escape(s) and position the "Recirc.-fresh air" control to the extreme right position (fresh-air).

8. "Feet air outlet" control

This control is used to control the air flow delivered under the dash on the driver's side. Turn control knob clockwise to increase air flow and counterclockwise to decrease.

9. "A/C auxiliary" switch

Push down rocker switch to actuate the optional auxiliary A/C system located at rear of coach to supplement the central A/C system. This system will operate only if central A/C system is operating.

How to use the controls

- To ventilate

Turn the "temperature" control knobs to the maximum counterclockwise position (cool), turn the "recirc.-fresh air" control knob to the maximum clockwise position (fresh air), then set the "A/C heat" switch to the "heat" position and turn the fan speed control knob to the desired position.

- To heat

STARTING AND STOPPING PROCEDURES

To ensure maximum efficiency of heating system, set the "A/C - heat" switch to the "heat" position, switch the fan speed control to the highest speed position, then adjust the temperature control knobs to a comfortable setting.

- To defrost

To obtain the maximum defrosting efficiency, switch the "fan" speed control to the highest position, set the "hot water pump" switch to the "ON" position, turn the "recirc.-fresh air" control knob to the maximum clockwise position (fresh air), turn the "feet air outlet" control knob to the maximum counterclockwise position (defrost position), then turn the "temperature" control to the maximum clockwise position (warm).

- To dehumidify

Because an air conditioner dehumidifies as it cools, you can use it in cool weather to help in drying air. Set the "A/C - heat" switch to the "A/C" position, then adjust the "temperature" control to a comfortable setting. With this set-up, the A\C and heating will run simultaneously, thus drying air as it flows through the evaporator and then heating it as it flows through the heater radiator.

CAUTION: The air conditioning system should not be used when outside temperature is below 40° F (5°C).

- To turn everything OFF

Set the "A/C heat" switch and "fan speed" control knob to the "OFF" position and turn the "temperature" control knobs to the maximum counterclockwise position (cool).

An adjustable air intake damper is located in the evaporator compartment (third compartment on the L.H. side of vehicle). The damper should normally be left open. However, under extreme temperature conditions, it can be closed or partially closed to block the addition of ambient air and heat or cool air inside of coach as desired. As soon as extreme heating or cooling is no longer required, the damper should be reopened.

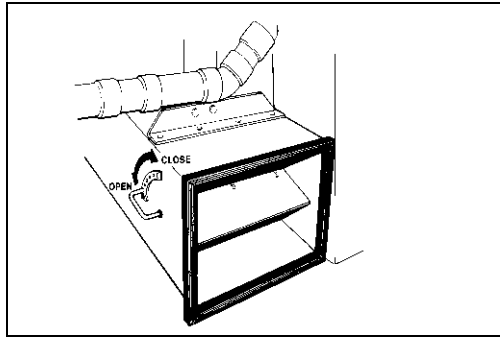

22004

PREHEATING SYSTEMS

(Optional)

ESPAR (EBERSPÄCHER):

Description of operations

This Auxiliary Preheating System is used for preheating and retaining the heat of water-cooled engines. It can be used before starting the engine to ease its starting and to provide immediate inside heat upon operation of the heating system. It can also be used with engine running to maintain coolant heat and maintain the set temperature inside vehicle.

The heater operates independently of the vehicle engine. It is connected to the cooling and heating circuits, the fuel system and the electrical system of the vehicle.

The pilot lamp turns on when the heater is switched on. Combustion air flows in to flush out the combustion chamber, and the water circulation pump is put into operation. The fuel metering pump conveys fuel in precise doses to the combustion chamber, where fuel and combustion air form a combustible mixture which is ignited by the glow plug.

Once the flame sensor has signalled to the control unit that combustion has taken place correctly, the glow-spark plug and ignition coil are switched off.

The hot combustion gases are diverted at the end of the flame pipe, then pass through the indirect heating surfaces of the heat exchanger and

STARTING AND STOPPING PROCEDURES

transmit their heat to the water passing through the heat exchanger.

The heat is thermostatically controlled, and operates intermittently, i.e. the switched-on times of the burner vary depending on the heat requirement. The water temperature depends on the setting of the built-in water thermostat.

The water circulation pump remains in operation as long as the heater is operating - even in the regulation intervals and during the delayed cutout of the switched-off heater. The pump can also be operated independently of the heater by means of an appropriate circuit. The heater can be switched on at any time, i.e. during the delayed cutout period too. Ignition takes place once this delay time is over.

When the heater is switched off, the fuel supply is interrupted. The flame goes out, and at the same time a delayed cutout of some 2.5 minutes begins. The combustion air still flowing flushes the remaining combustion gases out of the chamber and cools off the hot parts on the exhaust side of the heat exchanger, while the water circulation pump still running transmits the heat present in the heat exchanger, thus preventing local overheats. Once the delayed cutout time is over, both the combustion air blower and the water circulation pump switch off automatically. A cutout will take place in case of any failure of the preheater.

WEBASTO:

Description of operations

Switch on the heater, the operation indicator lamp comes on and the heater motor & circulating pump begin to run. After about 10-25 seconds the solenoid valve opens and fuel is sprayed into the combustion chamber. At the same time the electronic ignition unit produces high voltage (8000V) and the mixture of fuel and air in the combustion chamber is ignited by the spark on the ignition electrodes. The flame is indicated by the flame detector, then the electronic ignition unit stops producing high voltage and combustion continues by itself (spark on electrodes is required only to ignite the flame). At this moment the heater is working and produces heat.

If the heater is switched off by the on/off switch, the solenoid valve interrupts fuel supply, combustion stops and indicator lamp turns off. Combustion air fan still blows air, cleaning the combustion chamber of any fumes and cooling down the combustion chamber. Coolant circulation pump pumps coolant, making a purge cycle for approximately 2-3 minutes, thus protecting the heater against overheating.

If the heater is not switched off by the on/off switch, the control thermostat will switch off the heater when coolant temperature reaches $165^{\circ} \pm 6^{\circ} \text{ F}$ ($75^{\circ} \pm 3^{\circ} \text{ C}$) and turns it on at $154^{\circ} \pm 9^{\circ} \text{ F}$ ($68^{\circ} \pm 5^{\circ} \text{ C}$). During this time the heater (combustion) is off, the indication lamp and coolant pump are on. Combustion air fan blows air for 2-3 minutes and then turns off.

WINDSHIELD WASHER RESERVOIR

Windshield washer reservoir is located in front left compartment (steering compartment) below driver's floor. This reservoir has a capacity of approximately 5 U.S. gallons (18,9 litres). Its spin-on type cover is provided with a removable cap to ease windshield washer reservoir filling. Reservoir supply should be checked regularly.

Spray jets are mounted under windshield wiper arms. The reservoir's fluid is forced by air pressure through rubber tubes into spray jets and onto windshield.



23011

STARTING AND STOPPING PROCEDURES

JUMP STARTING

Whenever it becomes necessary to start the engine while batteries are discharged, use another power source of the same voltage (24 volt DC), negative grounded and proper jumper cables.

WARNING: Procedures other than the one outlined could cause injury or damage from battery acid spray, explosion, or charging system overload.

- Never connect to the negative post of the discharged battery.
- Never allow the two vehicles or the jumper cable clamps to touch each other.
- Never attempt to jump start a vehicle if the discharged battery fluid is frozen or if the battery fluid level is low, as the battery may rupture or explode.
- Do not jump start vehicles equipped with maintenance-free batteries if the test indicator is light yellow.
- Turn off all lights, heaters and other electrical accessories. Make sure the parking brake is applied and the transmission is set to "NEUTRAL" before attempting to jump start the engine.

Wear eye protection and remove rings, watches with metal bands and other metal jewelry.

1. Connect one end of the red jumper cable to the positive (+) post of the booster power source.
2. Remove the red protective cap from Booster Block's Positive Stud, then connect the other end of the red jumper cable to this stud.
3. Connect one end of the black jumper cable to the negative (-) post of the booster power source.
4. Remove the black protective cap from Booster Block's Negative Stud, then connect the other end of the black jumper cable to this stud.
5. Start the engine in the vehicle that is providing the jump start. Let the engine run for a few minutes, then start the engine in the vehicle that has the discharged batteries.

WARNING: Do not engage starter for more than 15 seconds. Allow starter time to cool before engaging again. This will prevent starter from overheating and will allow time delay relay time to cool.

6. To remove the cables, perform the above procedure in reverse order, then replace the protective sealant, if possible.

NOTE: Jumper cables must withstand 500 cranking amperes. If cable length is 20 feet (6 m) or less, use 2/0 (AWG) gage wires. If cable length is between 20-30 feet (6-9 m), use 3/0 (AWG) gage wires.

NOTE: If, after doing this procedure, Starter turns but Engine still doesn't run; (with Jumper Cables in place) wait approximately 15 minutes (to give battery equalizers time to balance 12V and 24V charges), then try again. If engine still doesn't run, repeat procedure once again.

On **XL-40** vehicles, booster block is located in the engine compartment and is accessible through engine R.H. side door.

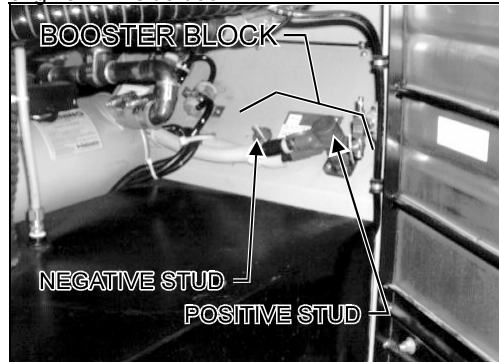

On **XL-45** vehicles, booster block is located in main power compartment.

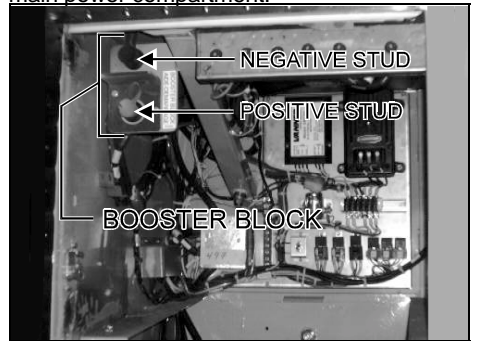

ELECTRIC CIRCUIT PROTECTION

Two types of cutoff mechanisms are installed to protect the vehicle's electrical system; fuses and manually-resettable circuit breakers. If an electrical device is inoperative, check the corresponding cutoff mechanism.

CAUTION: Never replace a fuse with a higher rated one because it will cause severe damage to the electrical system.

Main breakers

Most of the manually-resettable circuit breakers are located in the front & rear junction boxes and in the rear baggage compartment (XL-40) or the main power compartment (XL-45). An identification decal is affixed on the inside face of each door.

XL-40 vehicles are equipped with six (6) main breakers; they are installed just below R.H. side baggage compartment's ceiling and can be identified as follows:

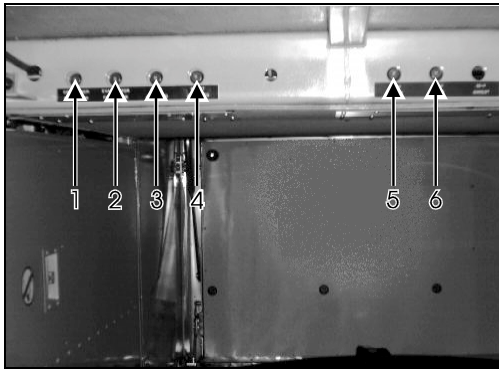

06099

- | | |
|-------------------------------|-------------------|
| 1. Condenser fan motor (CB8) | 105 amps-24 volts |
| 2. Evaporator fan motor (CB9) | 105 amps-24 volts |
| 3. Rear junction box (CB7) | 90 amps-24 volts |
| 4. Front junction box (CB6) | 90 amps-24 volts |
| 5. Front junction box (CB4) | 90 amps-12 volts |
| 6. Rear junction box (CB3) | 70 amps-12 volts |

XL-45 vehicles are equipped with eleven (11) main breakers; five (5) are installed on A/C junction box located in condenser compartment and the other six (6) are installed in main power compartment and can be identified as follows:

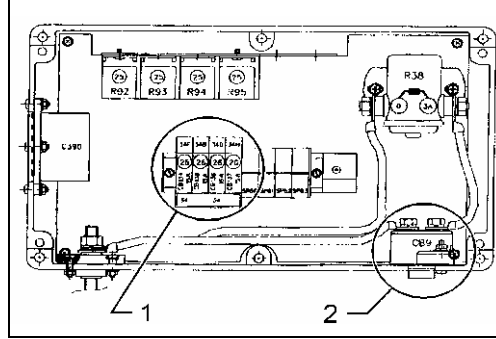

A/C junction box

06100

1. (From left to right)

- | | |
|----------------------------|------------------|
| CB134: Condenser fan motor | 15 amps-24 volts |
| CB135: Condenser fan motor | 15 amps-24 volts |
| CB136: Condenser fan motor | 15 amps-24 volts |
| CB137: Condenser fan motor | 15 amps-24 volts |

2. CB9: Evaporator fan motor 105 amps-24 volts

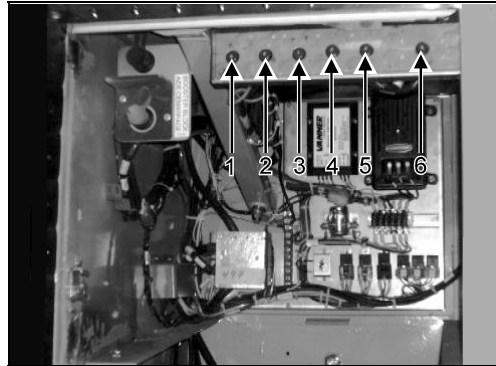

06101

- | | |
|--------------------------------|-------------------|
| 1. Rear junction box (CB3) | 70 amps-12 volts |
| 2. Front junction box (CB4) | 90 amps-12 volts |
| 3. Video system (Opt.) (CB131) | 40 amps-12 volts |
| 4. Rear junction box (CB6) | 90 amps-24 volts |
| 5. Front junction box (CB7) | 90 amps-24 volts |
| 6. A/C main (CB1) | 200 amps-24 volts |

Locate burned fuses as follows:

R.H. console (at back of temperature control buttons)

Temperature control.....1.5 amps (qty=2)

Rear L.H. side baggage compartment ceiling
(for vehicles equipped with video system)

Video inverter2 amps (qty=2)

To gain access to the fuses, simply remove the inverter's front protective screen.



Steering compartment

Kneeling module.....3 amps (qty=1)

Speed limit switch.....3 amps (qty=2)

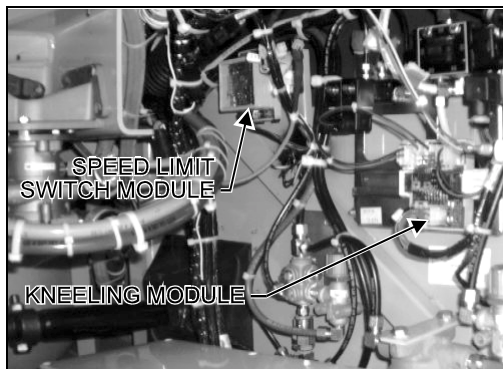

Battery equalizers

On **XL-40** vehicles the two (2) battery equalizers ("VANNER"-50 amps-12 & 24 volts) are installed just below L.H. side baggage compartment's ceiling. The reset buttons are located on the end of equalizers facing the center of the coach.

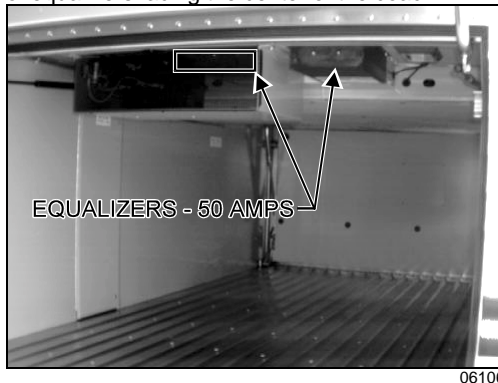

XL-45 vehicles have one (1) equalizer ("VANNER"-100 amps-12 & 24 volts). It is located inside Main power compartment and is equipped with auto reset, therefore there is no reset button.

TIRES

Tire pressure

The condition and pressure of the tires can greatly affect both useful tire life and road safety.

NOTE: The recommended tire inflation pressures are given in the "Technical Information" section, page 5-2. Also, cold tire inflation pressures are listed on the Department of Transport's certification plate, affixed below L.H. side control panel in driver's area. Tire pressure must be adjusted according to vehicle loading - see table in "Coach Final Record" (NOT NECESSARILY THE V.I.N. PLATE).

At regular intervals, verify the tire pressures. Use an accurate tire pressure gauge when checking inflation pressures. Never exceed the maximum tire inflation pressure specified on each tire.

Cold tire inflation pressure means: When a vehicle has not been driven for at least 3 hours or less than 1 mile (1.6 km).

STARTING AND STOPPING PROCEDURES

WARNING: Incorrect tire pressures cause increased tire wear and adversely affect road holding of the vehicle, leading to loss of vehicle control.

NOTE: Always include the spare tire during a pressure verification.

Changing wheels

Tire failure is a rare event these days, if tires are properly cared for. In case of a flat tire, move vehicle a safe distance away from traffic and apply the parking brake. Remember to switch "ON" the hazard flashers and according to the highway code regulations, set up the triangular reflectors (see "Emergency warning reflectors" on page 3-6) at an adequate distance to warn incoming motorists.

Spare wheel and tire are stored in the Spare wheel and tire compartment and are accessible by lowering the reclining front bumper. Use the wheel nut wrench to unscrew the two (2) bumper retaining bolts.

WARNING: It is recommended that two (2) people do this operation since bumper weighs 100lbs (45kg).

CAUTION: This compartment has not been designed for storage. Never leave any loose objects in this area since they may interfere with steering linkage mechanism.

Removing spare wheel and tire from compartment

To pull out spare wheel and tire, open reclining bumper according to the previous instructions, unscrew the wing nut retaining the support and rail extension assembly (stored on R.H. side of wheel), then take out the assembly. Install assembly by matching its two (2) holes to the corresponding mounting pins located in front center of spare tire compartment. Unscrew the retaining bracket's T-handle to release the wheel and dolly assembly and pull out bracket. Pull out wheel using strap then remove tire covering.

Separate wheel and tire from dolly by unscrewing the two (2) mounting nuts.

CAUTION: After reclining bumper has been secured, the two (2) retaining bolts should be checked to make sure that they are tightly fastened.

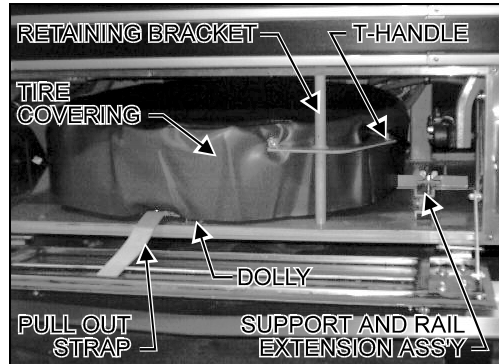

13005

NOTE: Reinstall support and rail extension assembly, then secure tire with retaining bracket before moving vehicle.

Jack and wheel nut wrench are stored at right in forward R.H. side baggage compartment.

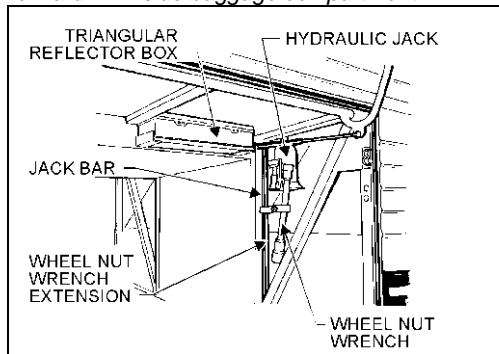

23012

Check the spare tire's inflation pressure periodically to keep it ready for use. Inflate spare tire to the pressure of the tire which has the highest pressure on the vehicle. Also, make sure that retaining bracket is securely fastened in order to prevent it from moving around inside compartment.

19

STARTING AND STOPPING PROCEDURES

Procedure

Step 1

Stop engine, apply parking brake, take out jack and wrench, then remove spare wheel and tire from their compartment.

Step 2

Remove hub cap (with appropriate wrench) or cover from wheel.

Step 3

With supplied wrench, loosen all wheel nuts to about one (1) full turn.

NOTE: For stud-mounted wheels, turn nuts counterclockwise on R.H. side of vehicle and clockwise on L.H. side. For hub-mounted wheels, turn nuts counterclockwise on both sides of vehicle.

Step 4

Use the hydraulic jack to raise the vehicle. Raise vehicle to the height required to remove wheel.

NOTE: For hydraulic jack placement, refer to "Jacking points", next in this section.

WARNING: Place jack on stable and level ground; if necessary, place a board under the jack.

Do not raise the vehicle until you are sure the jack is securely engaged.

WARNING: To prevent personal injury and/or equipment damage, use only the recommended jacking points.

Passengers must not remain inside vehicle while wheel is being replaced.

Step 5

Fully unscrew the wheel nuts, then remove nuts and wheel. Install spare wheel with existing nuts,

then slightly tighten nuts in a crisscross pattern before lowering the vehicle.

Step 6

Lower vehicle (until tire touches ground) by slowly unscrewing the jack's hydraulic valve.

Step 7

Torque all nuts, in a crisscross pattern, to 450-500 ft•lbs (610-680 N•m).

Step 8

Completely lower the coach and remove jack. Adjust tire pressure according to the cold tire inflation pressures.

Step 9

Store damaged wheel in spare tire compartment. Repair and balance the flat tire as soon as possible.

TOWING

Two tow eyes are provided at front and rear under vehicle. Towing should be done from these points only. A solid link tow bar and safety chain must be used. This recommended method prevents damaging the vehicle. If required, connect an auxiliary air supply to the vehicle to actuate the vehicle brakes. The engine cannot be started by pushing or towing.

WARNING: Never allow passengers to ride in a towed vehicle for any reason whatsoever.

CAUTION: Internal lubrication of the transmission is inadequate when the vehicle is towed. The propeller shaft or the axle shafts should be removed when being towed to avoid the possibility of damaging transmission.

NOTE: When the propeller or axle shafts are reinstalled, ensure the nuts are tightened to the appropriate torques and the axle shafts are properly installed (R.H. & L.H.) and/or the propeller shaft is properly phased. Refer to the "Maintenance Manual" for torque values.

STARTING AND STOPPING PROCEDURES

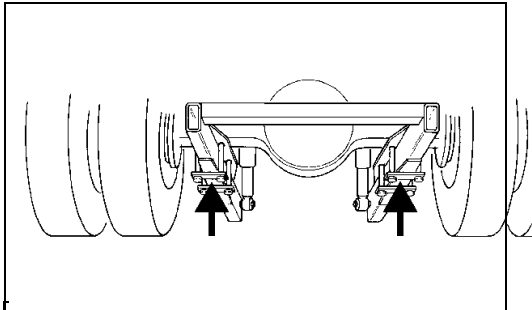

Drive Axle Jacking Points 11005

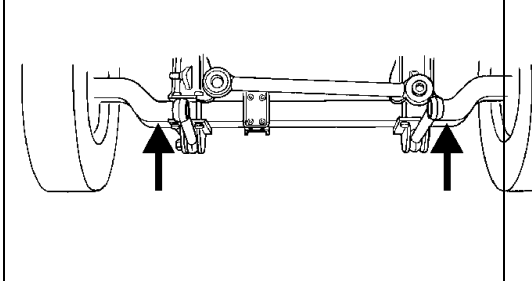

Front Axle Jacking Points 10005

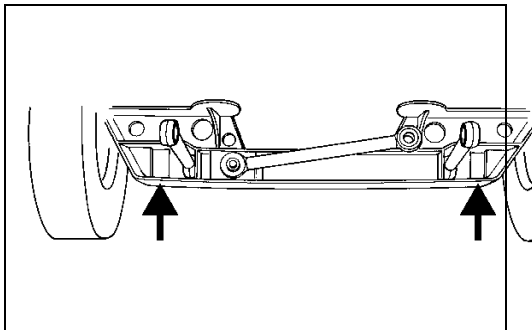

Tag Axle Jacking Points 11006

JACKING POINTS

One (1) jacking point on each side of each axle is provided on vehicle. Refer to the following illustrations for details.

CAUTION: Remember that only these jacking points can be used.

CAUTION: The jacking points on tag axle must be used only to lift this axle.

CAUTION: To prevent damage to suspension components, always raise or unload tag axle before jacking coach.

Several kinds of hydraulic jacks can be used but must all support the following capacities:

Front axle - 13,000 lbs (5 900 kg)

Drive axle - 25,000 lbs (11 365 kg)

RETRACTABLE TAG AXLE

Operation of the tag axle is controlled by a valve located on the L.H. Lateral Console. The valve can be flipped to either one of two positions, "Wheels up" or "Wheels down". Axle will automatically be raised or lowered by air pressure according to valve position (see page 2-20).

Tag axle service brakes operate only when axle is down. Never lower tag axle while vehicle is moving. When tag axle is up, the corresponding indicator light will illuminate, and a beep will sound to remind you that axle is up. Tag axle can be raised in tight maneuvering areas as in parking lots or to help in turning a short corner, thus shortening the wheelbase and allowing tighter turning. Raising tag axle transfers extra weight and additional traction to the drive wheels on a slippery surface.

CAUTION: Always raise tag axle before lifting vehicle to prevent damage to suspension components.

After either of the above uses, vehicle must be stopped, then tag axle must be lowered before resuming normal driving.

TAG AXLE UNLOADED

This standard system allows unloading of the tag axle air springs, without raising the axle. This system is controlled by the same valve that applies to the retractable tag axle, and is used in the same situations described in "RETRACTABLE TAG AXLE" section. Follow the same recommendations that apply to the retractable axle.

TABLE OF CONTENTS

STARTING AND STOPPING

PROCEDURES 4 - 1

| | |
|--|--------|
| General information..... | 4 - 1 |
| Detroit Diesel Electronic Control (DDEC)..... | 4 - 3 |
| World Transmission WT Electronic Control System..... | 4 - 4 |
| Manual transmission..... | 4 - 8 |
| Cold weather starting..... | 4 - 8 |
| Daily inspection..... | 4 - 9 |
| Recommendations..... | 4 - 10 |
| Heating and air conditioning..... | 4 - 11 |
| Preheating systems..... | 4 - 14 |
| Windshield washer reservoir..... | 4 - 15 |
| Jump starting..... | 4 - 16 |
| Electric circuit protection..... | 4 - 17 |
| Tires..... | 4 - 18 |
| Towing..... | 4 - 20 |
| Jacking points..... | 4 - 21 |
| Retractable tag axle..... | 4 - 21 |
| Tag axle unloaded..... | 4 - 21 |

TECHNICAL INFORMATION 5 - 1

| | |
|------------------------|-------|
| Dimensions..... | 5 - 1 |
| Weights..... | 5 - 2 |
| Capacities..... | 5 - 2 |
| Fuel type..... | 5 - 2 |
| Wheels and tires..... | 5 - 2 |
| Belts..... | 5 - 3 |
| Engines..... | 5 - 3 |
| Transmissions..... | 5 - 3 |
| Drive axle ratio..... | 5 - 3 |
| Brakes..... | 5 - 4 |
| Steering..... | 5 - 4 |
| Electrical system..... | 5 - 4 |
| Sound system..... | 5 - 4 |
| Video system..... | 5 - 4 |
| Suspension..... | 5 - 4 |

| | |
|---|--------|
| Alignment..... | 5 - 5 |
| Heating and air conditioning..... | 5 - 5 |
| Oil specifications..... | 5 - 5 |
| Antilock braking system (ABS)..... | 5 - 6 |
| Preheating systems..... | 5 - 6 |
| Storage volume..... | 5 - 6 |
| Seats..... | 5 - 7 |
| DDEC III diagnostic codes..... | 5 - 7 |
| World transmission WT diagnostic codes..... | 5 - 10 |
| Light bulb data..... | 5 - 25 |
| Data plate and certification..... | 5 - 27 |

CARE AND MAINTENANCE 6 - 1

| | |
|---|--------|
| Interior cleaning..... | 6 - 1 |
| Exterior cleaning..... | 6 - 3 |
| Oil verification..... | 6 - 4 |
| Air tanks..... | 6 - 7 |
| Coolant level verification..... | 6 - 8 |
| Water separator..... | 6 - 8 |
| Belt tensioners..... | 6 - 8 |
| A/C and heating air filters..... | 6 - 10 |
| Flexible hose maintenance..... | 6 - 10 |
| Lubrication..... | 6 - 11 |
| Fire extinguishers..... | 6 - 11 |
| 110-120 volt in-station lighting..... | 6 - 11 |
| 110-120 volt in-station connectors..... | 6 - 11 |
| Back-up camera..... | 6 - 12 |
| Filter restriction indicator..... | 6 - 12 |
| Lavatory maintenance..... | 6 - 12 |
| First service on new vehicle..... | 6 - 14 |
| Lubrication and servicing schedule..... | 6 - 15 |

SERVICE LITERATURE 7 - 1

PREVOST

XL Series Motorcoach TECHNICAL INFORMATION

DIMENSIONS

| SPECIFICATION | XL-40 | XL-45 |
|--|-------------------|-------------------|
| Overall length | 40.0' (12 192 mm) | 45.0' (13 716 mm) |
| Overall width | 102" (2 591 mm) | 102" (2 591 mm) |
| Overall height (over closed roof hatch(es)) | 130.7" (3 320 mm) | 130.7" (3 320 mm) |
| Entrance door width | 26" (660 mm) | 26" (660 mm) |
| Headroom (Floor to ceiling) | 76.5" (1 943 mm) | 76.5" (1 943 mm) |
| Aisle width | 14" (356 mm) | 14" (356 mm) |
| Step height from ground | 15" (381 mm) | 15" (381 mm) |
| Other step height | 8.5" (216 mm) | 8.5" (216 mm) |
| Cabin floor height | 48.5" (1 232 mm) | 48.5" (1 232 mm) |
| Ground clearance | 11" (279 mm) | 11" (279 mm) |
| Wheel base (Front axle's center to drive axle's center) | 280" (7 112 mm) | 315" (8 001 mm) |
| Front overhang | 69" (1 753 mm) | 69" (1 753 mm) |
| Rear overhang | 77.5" (1 969 mm) | 102.5" (2 604 mm) |
| Front track | 85.67" (2 176 mm) | 85.67" (2 176 mm) |
| Drive track | 76.5" (1 943 mm) | 76.5" (1 943 mm) |
| Rear track (Tag axle) | 82" (2 083 mm) | 82" (2 083 mm) |
| Turning circle radius (Exterior front corner) | 41.5' (12,65 m) | 45.58' (13,89 m) |

WEIGHTS

Dry weight (w/series 60 & World trans.)

| | |
|-------------|------------------------|
| XL-40 | 29 350 lbs (13 208 kg) |
| XL-45 | 30 850 lbs (13 882 kg) |

Dry weight (w/series 50 & World trans.)

| | |
|-------------|------------------------|
| XL-40 | 28 940 lbs (13 023 kg) |
| XL-45 | 30 440 lbs (13 698 kg) |

Gross vehicle weight rating

| | |
|-------------|------------------------|
| XL-40 | 42 690 lbs (19 211 kg) |
| XL-45 | 46 800 lbs (21 060 kg) |

Gross axle weight rating

| | |
|-----------------|-----------------------|
| Front axle..... | 14 400 lbs (6 545 kg) |
| Drive axle..... | 20 400 lbs (9 270 kg) |
| Tag axle..... | 12 000 lbs (5 450 kg) |

The Gross Vehicle Weight Rating (G.V.W.R.) and the Gross Axle Weight Ratings (G.A.W.R.) for front, drive and rear axles are listed on a certification plate located on the panel at the L.H. side of driver's seat, under the side control panel.

CAPACITIES

Engine oil (series 60)

| | |
|--------------------|--------------------------|
| Crankcase | 37 U.S. qts (35 liters) |
| Reserve tank | 10 U.S. qts (9,5 liters) |

Engine oil (series 50)

| | |
|--------------------|---------------------------|
| Crankcase | 29.5 U.S. qts (28 liters) |
| Reserve tank | 10 U.S. qts (9,5 liters) |

Fuel tank

| | |
|-------------|----------------------------|
| XL-40 | 160 U.S. gal. (606 liters) |
| XL-45 | 208 U.S. gal. (787 liters) |

Auxiliary fuel tank

| | |
|------------------|---------------------------|
| (Optional) | 90 U.S. gal. (341 liters) |
|------------------|---------------------------|

Cooling system..... 24 U.S. gal. (91 liters)

Transmissions

Automatic transmission
(excluding external circuits) 10 U.S. gal. (38 liters)

Manual transmission

| | |
|--------------|-----------------------------|
| 7 speed..... | 24 U.S. qts (22,7 liters) |
| 6 speed..... | 20.5 U.S. qts (19,4 liters) |

Differential oil 13.7 U.S. qts (13 liters)

Power steering

reservoir 4.0 U.S. qts (3,8 liters)

Windshield washer

reservoir 5 U.S. gal. (18,9 liters)

Refrigerant

Driver's system (XL-40) 6 lbs (2,7 kg)

Driver's system (XL-45) 6.5 lbs (3 kg)

Driver's and central system 24 lbs (11kg)

FUEL TYPE

ASTM specification D-975

Recommended grade 1-D

Acceptable grade 2-D

WHEELS AND TIRES

Steel wheels..... 8.25 X 22.5

Inner drive axle..... 8.25 X 22.5

Aluminum forged wheels..... 9 X 22.5

Except inner drive axle (steel) 8.25 X 22.5

Tires 12 R 22.5

Maximum loading tire inflation pressure (cold)

Front axle 115 psi (792 kPa)

Drive axle 90 psi (620 kPa)

Tag axle..... 95 psi (655 kPa)

NOTE: It is recommended that all tires on coach be of the same type.

CAUTION: These tire pressures are established in accordance with the maximum allowable load on each axle. A lower pressure is recommended if the axle load is less than the above specifications. Weigh vehicle fully loaded and pressurize according to tire manufacturer's recommendations. For other tire and wheel

TECHNICAL INFORMATION

specifications, see *Prévost tire pressure tabulation in "Coach Final Record"*.

BELTS

Radiator fan drive (transfer) (series 60 only)

Make:Gates
Model:AX 74
Qty:3

Radiator fan drive (transfer) (series 50 only)

Make:Gates
Model:AX 73
Qty:3

Radiator fan drive (fan)

Make:Dayco
Model:Multi-V, Poly rib, 51"
Qty:1

Carrier compressor (central A/C system)

Make:Gates
Model:BX 97
Qty:2

Alternator 24 V 270 amps

Make:Detroit Diesel
Model:Poly-V, 12K 72"
Qty:1

ENGINES

Detroit Diesel DDEC III Series 60, 12.7 liters inline 6 cylinders, 400 BHP.

Detroit Diesel DDEC III Series 60, 11.1 liters inline 6 cylinders, 325 BHP.

Detroit Diesel DDEC III Series 50, 8.5 liters inline 4 cylinders, 315 BHP.

TRANSMISSIONS

Automatic transmission

Allison six speed automatic World Transmission B500 or B500R with Electronic Control.

| Gear | Ratio |
|------|-------|
|------|-------|

| | |
|-----------------------|------|
| 1 st | 3.51 |
| 2 nd | 1.91 |
| 3 rd | 1.43 |
| 4 th | 1.00 |
| 5 th | 0.74 |
| 6 th | 0.64 |
| Rev | 4.80 |

Converter (Series 60, 12.7 liters)

prior 2P9L33402S1001468 1.58
from 2P9L33402S1001468 and including
2P9M33494S1001460..... 1.79

Converter (Series 60, 11.1 liters and Series 50)

..... 2.34
Output retarder..... (Optional)

NOTE: Gear ratios do not include torque converter multiplication.

Manual transmissions

Spicer PS145-7A, 7-speed

| Gear | Ratio |
|-----------------------|-------|
| 1 st | 10.13 |
| 2 nd | 5.99 |
| 3 rd | 3.56 |
| 4 th | 2.57 |
| 5 th | 1.84 |
| 6 th | 1.33 |
| 7 th | 1.00 |
| Rev | 10.13 |

Spicer PS130-6B, 6-speed

| Gear | Ratio |
|-----------------------|-------|
| 1 st | 8.53 |
| 2 nd | 4.87 |
| 3 rd | 3.00 |
| 4 th | 1.90 |
| 5 th | 1.33 |
| 6 th | 1.00 |
| Rev | 8.53 |

DRIVE AXLE RATIO

World transmission (Series 60) 4.89:1 (std)
..... 4.56:1 (opt)

World transmission (Series 50) 4.89:1

Manual transmissions (Series 60)3.07:1 (std)
.....3.21:1 (opt)

Manual transmissions (Series 50) 3.21:1

BRAKES

- Air operated, disc type on front axle and tag axle, drum type on drive axle.
- Brake chamber type 30 on front axle, 30-36 on drive axle and 16/24 on tag axle.
- Automatic slack adjuster.
- Two cylinder air compressor, engine gear driven, water-cooled and lubricated.
- Air dryer.
- Nylon color-coded air lines.

STEERING

- Tilt steering wheel and telescopic steering column.
- Integral hydraulic-assisted steering gear.
- System pressure 2000 psi (13 790 kPa).

ELECTRICAL SYSTEM

24 & 12 volt negative grounded

Alternator - 270 amps/24 volts

Four (4) model 1150, 12 volt maintenance-free batteries, each with a 625 cold cranking amp capacity.

Battery equalizer(s)

Wiring protection: fuses, manual and automatic resettable circuit breakers

12 volt and 24 volt main disconnect switch(es)

SOUND SYSTEM

Twelve (XL-40) or sixteen (XL-45) Hi-Fi speakers in passengers' area (standard)

Two Hi-Fi speakers in driver's area (optional)

Deluxe AM/FM cassette sound system (optional)

Compact disc player - 10 stacks (optional)

PA system with volume control (standard)

Microphone jacks (two standard)

Cellular phone antenna (optional)

CB antenna

VIDEO SYSTEM (optional)

TV converter ("Starcom 7V") with remote control "Panasonic" videocassette player with remote control model VHS AG-1000B with remote control

TV monitors (mounted under parcel racks) model ST-1001 (qty= 3 or 5)

TV receiver (with video system only)

SUSPENSION

Front axle

- 2 air springs
- 2 shock absorbers
- 3 longitudinal radius rods
- 1 transversal radius rod
- 1 height control valve
- 1 sway bar

Drive axle

- 4 air springs
- 4 shock absorbers
- 3 longitudinal radius rods
- 1 transversal radius rod
- 2 height control valves

Tag axle

- 2 air springs
- 2 shock absorbers
- 3 longitudinal radius rods
- 1 transversal radius rod

Extra lift and/or extra low suspension
Hi-Buoy system (optional)

Low-Buoy system (optional)

Kneeling system (optional)

ALIGNMENT

Front axle

Toe-in:..... 3/32" ± 1/32" (2,4 mm ± 0,8 mm)
Caster: + 2 1/2° to + 4 3/4° (+ 3° desired)
Camber: - 1/8° ± 7/16°

Tag axle

Toe:..... 0" ± 1/16" (0 mm ± 1,6 mm)

**HEATING AND AIR
CONDITIONING**

Driver's system

Refrigerant type:..... R-134a
Heating capacity: 37,800 Btu/hr.
Air flow: 450 cfm (12,74 m³/min.)

Central system

Air conditioning capacity: . 110 000 Btu/hr. (XL-45)
Air conditioning capacity: ... 98 000 Btu/hr. (XL-40)
Refrigerant type:..... R-134a
Heating capacity: 152,000 Btu/hr.
Air flow: 2,700 cfm (76,45 m³/min.)

A/C COMPRESSOR

Number of cylinders: 6
Operating speed:..... 400 to 2,200 rpm
(1,750 rpm, nominal)
Minimum speed for lubrication:..... 400 rpm
Oil capacity: 1.13 U.S. gal. (4,3 liters)
Approved oils: Castrol SW-68 (POE)
Mobil Artic 1 (POE)

NOTE: *The above oils are suitable for use with reciprocating compressors using refrigerant R-134a and with evaporator temperatures above -40°F (-40° C).*

OIL SPECIFICATIONS

Engine

Heavy-duty engine oil SAE 15W-40 meeting MIL-L-2104E or F specification.

Transmissions

Automatic

The transmission must be filled with DEXRON IIE or III automatic transmission fluid or any equivalent Class C4 fluids.

Manual

Same as engine oil.

Differential

Multigrade gear lubricants are recommended for use in drive axle. These lubricants perform well over broad temperature ranges, providing good gear and bearing protection in a variety of climates.

Two categories of multigrade gear lubricants may be used according to the climate in which you drive.

| <u>Climate</u> | <u>Lubricant</u> |
|----------------|------------------|
| Northern | 75W-90 |
| Southern..... | 80W-140 |

Fan gearbox

Synthetic oil Mobil SHC 634 is recommended for the fan gearbox.

Power steering reservoir

This reservoir must be filled with DEXRON IIE or III automatic transmission oil.

Wheel bearings

The front and tag axle wheel bearings must be filled to the level mark in the cap using SAE 90 oil.

TECHNICAL INFORMATION

Drive axle wheel bearings are lubricated by the differential oil. Maintain differential oil level to ensure adequate lubrication of drive axle wheel bearings at all times.

On vehicles equipped with grease-lubricated wheel bearings, pack with wheel bearing grease.

A/C compressor

Polyolester oil, HFC 134A compatible; Castrol SW-68 (POE) or equivalent.

Clutch master cylinder

This reservoir must be filled with DOT 3 heavy-duty brake fluid.

ANTILOCK BRAKING SYSTEM (ABS) (optional)

Components: Electronic Control Module (ECM)
Solenoid control valves
Sensors
Clamping bushes
Wiring harnesses

Electronic control module technical data

Voltage:.....24 ± 6 volts
Thermal operating range:..... -40 to 167 °F
(-40 to 75 °C)

Protection system for sealed multi-pin plug according to DIN 40050

Electrical connection is made through a 35 pin plug

Maintenance:..... none

Solenoid control valve technical data

Voltage:.....24 (+4.8, -2.4) volts
Current:..... DC
Rated current:..... 1.65 amps
Protection system according to DIN 40050
Maximum service pressure:..... 10 bars (145 psi)

Thermal operating range:.....-40 to 176 °F
(-40 to 80 °C)
Electrical connector:..... 894 601 010 2
Maintenance:..... none

Sensor technical data

Two cored screened cable:..... AWG 18 (1 mm²)
Force needed to tear out lead:..... 11.2 lbs (50 N)
Force needed to pull off shrink-fitted tube:
11.2 lbs (50 N)
Thermal operating range:.....-40 to 176 °F
(-40 to 80 °C)
Protection system according to DIN 40050

PREHEATING SYSTEMS (Optional)

ESPAR (EBERSPÄCHER)

Heater:.....Model D12W
Heating capacity:..... 12 kW
Heating output:.....41,000 Btu/hr
Fuel type:..... Same as engine
Fuel consumption:.....0.44 U.S. gal.
(1,65 litres) / hour
Rated voltage:..... 24 ± 4 volts
Electric power consumption:..... 55 watts

WEBASTO

Heater:..... Model DBW2020
Heating capacity:..... 23.3 kW
Heating output:..... 80,000 Btu/hr
Fuel type:..... Same as engine
Fuel consumption:.....0.8 U.S. gal.
(3 litres) / hour
Rated voltage:..... 24 ± 4 volts
Electric power consumption:..... 120 watts

STORAGE VOLUME

Exterior baggage compartments:
XL-40..... 315 ft³ / 8,9m³
XL-45..... 407ft³ / 11,5m³
Parcel racks:
XL-40..... 75ft³ / 2,13m³
XL-45..... 86ft³ / 2,43m³

SEATS

Seating capacity:

XL-40 51 passengers

XL-45 55 passengers

Several seating layouts may be achieved through a combination of available equipment with the addition or removal of some items such as passenger seats, card table(s), galley, lavatory etc..

DDEC III DIAGNOSTIC CODES

To read codes:

Use a diagnostic data reader plugged in receptacle on L.H. side control panel (item #18 on page 2-4) or momentarily depress the Stop engine "OVERRIDE" switch (located on the L.H. lower switch panel) with the ignition on, engine at idle or not running. Active codes will be flashed on the stop engine telltale (located on central dashboard), followed by the inactive codes being flashed on the check engine telltale (located on central dashboard). The cycle repeats until the operator depresses again the Stop engine "OVERRIDE" switch. A code "43" consists of four flashes, followed by a short pause, then three flashes in quick succession.

| DDC Code Number (Flashed) | Description | DDC Code Number (Flashed) | Description |
|---------------------------|--|---------------------------|---|
| 11 | Variable speed governor sensor voltage low | 12 | Variable speed governor sensor voltage high |
| 13 | Coolant level circuit failed low | 14 | Intercooler temperature circuit failed high |
| 14 | Coolant temperature circuit failed high | 14 | Oil temperature circuit failed high |
| 15 | Intercooler temperature failed low | 15 | Coolant temperature circuit failed low |
| 15 | Oil temperature circuit failed low | 16 | Coolant level circuit failed high |
| 17 | Bypass position circuit failed high | 18 | Bypass position circuit failed low |
| 21 | EFPA circuit failed low | 22 | EFPA circuit failed low |

TECHNICAL INFORMATION

| DDC Code Number (Flashed) | Description | DDC Code Number (Flashed) | Description |
|----------------------------------|--|----------------------------------|--|
| 23 | Fuel temperature circuit failed high | 24 | Fuel temperature circuit failed low |
| 25 | Reserved for "no codes" | 26 | Aux. shutdown #1 active |
| 26 | Aux. shutdown #2 active | 27 | Air temperature circuit failed high |
| 28 | Air temperature circuit failed low | 31 | Aux. output #3 open circuit (high side) |
| 31 | Aux. output #3 short to ground (high side) | 31 | Aux. output #4 open circuit (high side) |
| 31 | Aux. output #4 short to ground (high side) | 32 | SEL open circuit |
| 32 | SEL short to battery | 33 | Turbo boost pressure circuit failed high |
| 34 | Turbo boost pressure circuit failed low | 35 | Oil pressure circuit failed high |
| 36 | Oil pressure circuit failed high | 37 | Fuel pressure circuit failed high |
| 38 | Fuel pressure circuit failed low | 41 | Too many SRS (missing TRS) |
| 42 | Too few SRS (missing SRS) | 43 | Coolant level low |
| 44 | Intercooler temperature high | 44 | Coolant temperature high |
| 44 | Oil temperature high | 45 | Oil pressure low |
| 46 | Battery voltage low | 47 | Fuel pressure high |
| 48 | Fuel pressure low | 52 | A/D conversion fail |
| 53 | Nonvolatile checksum incorrect | 53 | EEPROM write error |
| 54 | Vehicle speed sensor fault | 55 | J1939 data link fault |
| 55 | Proprietary link fault (master) | 55 | Proprietary link fault (receiver) |
| 56 | J1587 data link fault | 57 | J1922 data link fault |
| 58 | Torque overload | 61 | Response time long |
| 62 | Aux. output #1 short to battery | 62 | Aux. output #1 open circuit |
| 62 | Aux. output #2 short to battery | 62 | Aux. output #2 open circuit |
| 62 | Aux. output #5 short to battery | 62 | Aux. output #5 open circuit |

TECHNICAL INFORMATION

| DDC Code Number (Flashed) | Description | DDC Code Number (Flashed) | Description |
|----------------------------------|--|----------------------------------|---|
| 62 | Aux. output #6 short to battery | 62 | Aux. output #6 open circuit |
| 62 | Aux. output #7 short to battery | 62 | Aux. output #7 open circuit |
| 62 | Aux. output #8 short to battery | 62 | Aux. output #8 open circuit |
| 63 | PWM #1 short to battery | 63 | PWM #1 open circuit |
| 63 | PWM #2 short to battery | 63 | PWM #2 open circuit |
| 63 | PWM #3 short to battery | 63 | PWM #3 open circuit |
| 63 | PWM #4 short to battery | 63 | PWM #4 open circuit |
| 64 | Turbo speed circuit failed | 65 | Reserved for air filter differential pressure circuit failed high |
| 65 | Reserved for air filter differential pressure circuit failed low | 66 | Reserved for oil filter differential pressure circuit failed high |
| 66 | Reserved for oil filter differential pressure circuit failed low | 67 | Coolant pressure circuit failed high |
| 67 | Coolant pressure circuit failed low | 68 | Idle validation circuit fault (grounded circuit) |
| 68 | Idle validation circuit fault (open circuit) | 71 | Injector response time short |
| 72 | Vehicle overspeed | 72 | Reserved for vehicle overspeed (absolute) |
| 73 | Reserved for air differential pressure high | 74 | Oil differential pressure high |
| 75 | Battery voltage high | 76 | Engine overspeed with engine brake |
| 77 | All other faults not listed | 81 | Timing actuator (dual fuel) failed high |
| 81 | Oil level circuit failed high | 81 | Crankcase pressure circuit failed high |
| 82 | Timing actuator (dual fuel) failed low | 82 | Oil level circuit failed low |
| 82 | Crankcase pressure circuit failed | 83 | Oil level high |

TECHNICAL INFORMATION

| DDC Code Number (Flashed) | Description | DDC Code Number (Flashed) | Description |
|---------------------------|-----------------------------------|---------------------------|---|
| | low | | |
| 83 | Crankcase pressure high | 84 | Oil level low |
| 84 | Crankcase pressure low | 85 | Engine overspeed |
| 86 | Pump pressure circuit failed high | 86 | Barometric pressure circuit failed high |
| 87 | Pump pressure circuit failed low | 87 | Barometric pressure circuit failed high |
| 88 | Coolant pressure low | -- | CEL short to battery |
| -- | CEL open circuit | -- | Clock Module failure |
| -- | Clock module abnormal rate | | |

WORLD TRANSMISSION (WT) DIAGNOSTIC CODES**Diagnostic code memory**

Diagnostic codes are logged in a list in memory (sometimes referred to as the queue), positioning the most recently occurring code first and containing up to five codes. The codes continued in the list have the information recorded as shown in the chart below. Access to the code list position, main code, sub code and active indicator is through either the shifter display or the Pro-Link Diagnostic Datareader (DDR). Access to the ignition cycle counter and event counter is through the DDR only.

| Code List Position | Main Code | Sub Code | Active Indicator | Ignition Cycle Counter | Event Counter |
|--------------------|-----------|----------|------------------|------------------------|---------------|
| d1 | 21 | 12 | YES | 00 | 10 |
| d2 | 41 | 12 | YES | 00 | 04 |
| d3 | 23 | 12 | NO | 08 | 02 |
| d4 | 34 | 12 | NO | 13 | 01 |
| d5 | 56 | 11 | NO | 22 | 02 |

| | | |
|--------------------------------------|------------------------------|---|
| Displayed on shifter display and DDR | YES= ACTIVE= "MODE ON" | Ignition cycle counter and event counter are not available on shifter display |
|--------------------------------------|------------------------------|---|

NOTE: All information is available with a DDR.

The following paragraphs define the different parts of the code list.

Code list position:

The position 1 through 5 which a code occupies in the code list in memory. Positions are shown as "d1" (Diagnostic Code #1) through "d5."

Main code

The general condition or area of fault detected by ECU.

Sub Code

The specific area or condition under the main code in which the condition was detected.

Active Indicator

Will be turned "on" when a fault condition is active (shifter will display "MODE ON" or the DDR will display "YES"). Will be set to "off" when conditions exist to indicate fault condition is gone.

Ignition cycle counter

Used to clear diagnostic codes that are inactive from the code list in memory. Counter is incremented each time a normal ECU powerdown occurs following clearing of the Active Indicator. Code will be cleared from the list when the counter exceeds 25.

Event counter

Used to count the number of occurrences of a diagnostic code that occur prior to the incident being cleared from the code list. The most recent code will be in position "d1". If the most recent code is one which is already in the code list, that code will be moved to position "d1", the Active Indicator will be turned "on" (shifter will display "MODE ON" or the DDR will display "YES"), the Ignition Cycle Counter is cleared and "1" is added to the Event counter.

Clearing the Active Indicator and code records from the Code list in memory:

If the conditions causing a diagnostic code to be set are cleared, the Active Indicator can be manually cleared by holding the "MODE" button down continuously for 3 seconds until a tone is heard from the shifter. To clear code records from the list, hold the "MODE" button down continuously for ten seconds until a second tone sounds. All diagnostic records in the list that are not active will then be cleared and the remaining records will then be moved up the list.

Code reading and code clearing procedures

Diagnostic codes can be read and cleared by two methods: by using the Pro-Link 9000 DDR plugged in receptacle located on L.H. lateral console or by using the shifter display. The use of the Pro-Link 9000 DDR is described in the instruction manual furnished with each tool. The method of reading and clearing codes described

in this section refers to only entering the Diagnostic Display Mode by the proper button.

The Diagnostic Display Mode may be entered for viewing of codes at any speed. Codes can only be cleared when the output speed = 0 and no output speed sensor failure is active.

The following descriptions explain how to use the shifter to read and clear codes:

Reading Codes:

1. Enter the diagnostic display mode by pressing the "↑" and "↓" (upshift and downshift arrows) buttons at the same time on the pushbutton shifter.

NOTE: *If a "DO NOT SHIFT" condition is present at this time, the lever should be in the same position as it was at time of code detection. If not, this shifter tone will sound continuously.*

NOTE: *If an oil level sensor is present, then oil level will be displayed first. Diagnostic code display is achieved by depressing the upshift and downshift arrows or display mode button a second time.*

2. Read the first code in the first of five code positions on the digital display of the shifter. For example, we will read code 25 11 in the first position. The display will change every two seconds as follows:

- a. Code list position --"d1"
- b. Main code --"25"
- c. Sub code --"11"
- d. Display will repeat cycle of a., b. and c. above

3. Press the "MODE" button momentarily to view the second position (d2) in the same way as 2. above.

4. To view the third, fourth and fifth positions (d3,d4 and d5), momentarily press the "MODE" button as explained above.

5. Pressing the "MODE" button momentarily after the fifth position is displayed will cause the sequence of code positions to start over with the first position.

6. Any code which is active will be indicated by the "MODE ON" indicator (active indicator) being turned on while in that code position (while in the normal operating mode, the "MODE ON" indicator is turned on to indicate "ECONOMY" mode operation, (refer to "Function of the mode button", on page 2-7)).

7. Any code position in the list which does not have a diagnostic code logged will display "- -" for both the main and sub code displays. All positions after a code position without any code will also not contain any codes.

Clearing Codes:

1. Clearing of the active indicator is automatically done at ECU powerdown on all but code 69 34 (see code list, page 5-14).

2. Some codes will clear the active indicator automatically when the condition causing the code is no longer detected by the ECU.

3. Manual clearing is possible while in the diagnostic display mode and after the condition causing to code is corrected (output speed must be zero).

- a. To clear all active indicators, hold the "MODE" button down continuously for 3 seconds until the shifter tone sounds for 0.5 seconds.

- b. Release the "MODE" button to return to normal operating mode. If the condition causing the code was not active at the time, the active indicator will turn off.

CAUTION: *If clearing a code while locked in a Forward or Reverse position (fail-to-range), the transmission will still be in Drive or Reverse when the clearing procedure is completed. Neutral must be manually selected.*

Exiting the diagnostic display mode:

The diagnostic display mode can be exited by any of the following procedures:

1. Press the "↑" and "↓" (upshift and downshift) buttons at the same time on the pushbutton shifter.
2. Press any range button, "D", "N" or "R", on the pushbutton shifter (the shift will be commanded if it is not inhibited by an active code).
3. Do nothing and wait until the calibrated time (approximately 10 minutes) has passed and the system automatically returns to the normal operating mode.
4. Turn off power to the ECU (turn off the vehicle at the ignition switch).
5. After the clearing the active indicator procedure described above has been performed.

Clearing records from the code list in memory

If the requirements for Manual Clearing the Active Indicator have been satisfied, and the "MODE" button is held down continuously for ten seconds while in the display mode until a tone sounds, all diagnostic records in the code list that are not

active will be cleared and the remaining records will be moved up in the code list.

Abbreviation found in the code chart

The following responses are used throughout the following chart to command safe operation when diagnostic codes are set.

• DNS (Do Not Shift) Response

- Turn off lockup clutch and inhibit lockup operation.
- Inhibit all shifts.
- Turn on *DO NOT SHIFT* light.
- Pulse the tone generator for 8 seconds when the condition is first detected.
- Blank the select digit in the display.
- Ignore any range selection inputs and disable the button feedback tone for the pushbutton shifter.

• SOL OFF (Solenoid Off) Response

- All solenoids are commanded off (turning solenoids "A" and "B" off electrically causes them to be on hydraulically).

• RPR (Return to Previous Range) Response

- When the ratio or C3 pressure switch tests associated with a shift are not passed, the ECU commands the same range as commanded at the beginning of the shift.

• NNC (Neutral No Clutches) Response

- When certain ratio or C3 pressure switch tests are not passed, the ECU commands a neutral condition with no clutches applied.

Diagnostic code list and description

| MAIN CODE | SUB CODE | DESCRIPTION | DO NOT SHIFT LIGHT | INHIBITED OPERATION DESCRIPTION |
|-----------|----------|--|--------------------|---|
| 12 | 12 | Oil level, low | No | No upshift above a calibration range |
| 12 | 23 | Oil level,high | No | No upshift above a calibration range |
| 13 | 12 | ECU input voltage, low | Yes | DNS, SOL OFF (Hydraulic default) |
| 13 | 13 | ECU input voltage, medium low | No | None: Shift adaptive feature will not function. |
| 13 | 23 | ECU input voltage, high | Yes | DNS, SOL OFF (Hydraulic default) |
| 14 | 12 | Oil level sensor, low | No | None |
| 14 | 23 | Oil level sensor, high | No | None |
| 21 | 12 | Throttle position sensor, low | No | Use Throttle default value |
| 21 | 23 | Throttle position sensor, high | No | Use Throttle default value |
| 22 | 14 | Engine speed sensor reasonableness test | No | Use default engine speed |
| 22 | 15 | Turbine speed sensor reasonableness test | Yes | DNS, Lock in current range |
| 22 | 16 | Output speed sensor reasonableness or rapid decel test | Yes | DNS, Lock in current range |
| 23 | 12 | Primary Shifter or RSI Link Fault | No | Hold in last valid direction |
| 23 | 13 | Primary Shifter Mode Function Fault | No | Mode change not permitted |
| 23 | 14 | Secondary Shifter or RSI Link Fault | No | Hold in last valid direction |
| 23 | 15 | Secondary Shifter Mode Function Fault | No | Mode change not permitted |
| 24 | 12 | Sump oil temperature, cold | Yes | DNS |
| 24 | 23 | Sump oil temperature, hot | No | No upshifts above a calibration range |
| 25 | 00 | Output speed reasonableness test, detected at 0 speed, (L) | Yes | DNS, Lock in current range (L) |

TECHNICAL INFORMATION

| MAIN CODE | SUB CODE | DESCRIPTION | DO NOT SHIFT LIGHT | INHIBITED OPERATION DESCRIPTION |
|------------------|-----------------|--|---------------------------|--|
| 25 | 11 | Output speed reasonableness test, detected at 0 speed, (1st) | Yes | DNS, Lock in current range (1 st) |
| 25 | 22 | Output speed reasonableness test, detected at 0 speed 2nd | Yes | DNS, Lock in current range (2nd) |
| 25 | 33 | Output speed reasonableness test, detected at 0 speed, 3rd | Yes | DNS, Lock in current range (3rd) |
| 25 | 44 | Output speed reasonableness test, detected at 0 speed, 4th | Yes | DNS, Lock in current range (4th) |
| 25 | 55 | Output speed reasonableness test, detected at 0 speed, 5th | Yes | DNS, Lock in current range (5th) |
| 25 | 66 | Output speed reasonableness test, detected at 0 speed, 6th | Yes | DNS, Lock in current range (6th) |
| 25 | 77 | Output speed reasonableness test, detected at 0 speed, R | Yes | DNS, Lock in current range (R) |
| 32 | 00 | C3 pressure switch open, L range | Yes | DNS, Lock in current range (L) |
| 32 | 33 | C3 pressure switch open, 3rd range | Yes | DNS, Lock in current range (3rd) |
| 32 | 55 | C3 pressure switch open, 5th range | Yes | DNS, Lock in current range (5th) |
| 32 | 77 | C3 pressure switch open, R range | Yes | DNS, Lock in current range (R) |
| 33 | 12 | Sump oil temperature sensor, low | No | Use default value of 200° F (93° C) |
| 33 | 23 | Sump oil temperature sensor, high | No | Use default value of 200° F (93° C) |
| 34 | 12 | EEPROM, factory cal. compatibility number wrong | Yes | DNS, SOL OFF (Hydraulic default) |
| 34 | 13 | EEPROM, factory calibration block checksum | Yes | DNS, SOL OFF (Hydraulic default) |
| 34 | 14 | EEPROM, Power Off Block checksum | Yes | Use previous location, or factory calibration and reset adaptive |

TECHNICAL INFORMATION

| MAIN CODE | SUB CODE | DESCRIPTION | DO NOT SHIFT LIGHT | INHIBITED OPERATION DESCRIPTION |
|------------------|-----------------|--|---------------------------|--|
| 34 | 15 | EEPROM, Diagnostic Queue Block Checksum | Yes | Use previous location, or clear diagnostic queue |
| 34 | 16 | EEPROM, Real Time Block Checksum | Yes | DNS, SOL OFF (Hydraulic default) |
| 35 | 00 | Power interruption (Code set after power restored) | No | NONE (Hydraulic default during interruption) |
| 35 | 16 | Real Time EEPROM Write Interruption | Yes | DNS, SOL OFF (Hydraulic default) |
| 36 | 00 | Hardware/Software not compatible | Yes | DNS, SOL OFF (Hydraulic default) |
| 41 | 12 | Open or short to ground, A solenoid circuit | Yes | DNS, SOL OFF (Hydraulic default) |
| 41 | 13 | Open or short to ground, B solenoid circuit | Yes | DNS, SOL OFF (Hydraulic default) |
| 41 | 14 | Open or short to ground, C solenoid circuit | Yes | DNS, SOL OFF (Hydraulic default) |
| 41 | 15 | Open or short to ground, D solenoid circuit | Yes | DNS, SOL OFF (Hydraulic default) |
| 41 | 16 | Open or short to ground, E solenoid circuit | Yes | DNS, SOL OFF (Hydraulic default) |
| 41 | 21 | Open or short to ground, F solenoid circuit | No | Lock-up inhibited |
| 41 | 22 | Open or short to ground, G solenoid circuit | Yes | DNS, SOL OFF (Hydraulic default) |
| 41 | 23 | Open or short to ground, H solenoid circuit | No | Retarder allowed, differential lock inhibited |
| 41 | 24 | Open or short to ground, J solenoid circuit | No | Low and 1st inhibited |
| 41 | 25 | Open or short to ground, K solenoid circuit | No | K solenoid operation inhibited |
| 41 | 26 | Open or short to ground, N solenoid circuit | No | Low and 1st inhibited |

TECHNICAL INFORMATION

| MAIN CODE | SUB CODE | DESCRIPTION | DO NOT SHIFT LIGHT | INHIBITED OPERATION DESCRIPTION |
|------------------|-----------------|--------------------------------------|---------------------------|---|
| 42 | 12 | Short to battery, A solenoid circuit | Yes | DNS, Lock in a range |
| 42 | 13 | Short to battery, B solenoid circuit | Yes | DNS, Lock in a range |
| 42 | 14 | Short to battery, C solenoid circuit | Yes | DNS, Lock in a range |
| 42 | 15 | Short to battery, D solenoid circuit | Yes | DNS, Lock in a range |
| 42 | 16 | Short to battery, E solenoid circuit | Yes | DNS, Lock in a range |
| 42 | 21 | Short to battery, F solenoid circuit | No | Lock-up inhibited |
| 42 | 22 | Short to battery, G solenoid circuit | Yes | DNS, Lock in a range |
| 42 | 23 | Short to battery, H solenoid circuit | No | Retarder allowed, differential lock inhibited |
| 42 | 24 | Short to battery, J solenoid circuit | No | Low and 1st inhibited |
| 42 | 25 | Short to battery, K solenoid circuit | No | K solenoid operation inhibited |
| 42 | 26 | Short to battery, N solenoid circuit | No | Low and 1st inhibited |
| 43 | 21 | Low side driver, F solenoid circuit | No | Lock-up inhibited |
| 43 | 25 | Low side driver, K solenoid circuit | No | K solenoid operation inhibited |
| 43 | 26 | Low side driver, N solenoid circuit | No | Low and 1st inhibited |
| 44 | 12 | Short to ground,A solenoid circuit | Yes | DNS, SOL OFF (Hydraulic default) |
| 44 | 13 | Short to ground,B solenoid circuit | Yes | DNS, SOL OFF (Hydraulic default) |
| 44 | 14 | Short to ground,C | Yes | DNS, SOL OFF |

TECHNICAL INFORMATION

| MAIN CODE | SUB CODE | DESCRIPTION | DO NOT SHIFT LIGHT | INHIBITED OPERATION DESCRIPTION |
|------------------|-----------------|------------------------------------|---------------------------|---|
| | | solenoid circuit | | (Hydraulic default) |
| 44 | 15 | Short to ground,D solenoid circuit | Yes | DNS, SOL OFF (Hydraulic default) |
| 44 | 16 | Short to ground,E solenoid circuit | Yes | DNS, SOL OFF (Hydraulic default) |
| 44 | 21 | Short to ground,F solenoid circuit | No | Lock-up inhibited |
| 44 | 22 | Short to ground,G solenoid circuit | Yes | DNS, SOL OFF (Hydraulic default) |
| 44 | 23 | Short to ground,H solenoid circuit | No | Retarder allowed. differential lock inhibited |
| 44 | 24 | Short to ground,J solenoid circuit | No | Low and 1st inhibited |
| 44 | 25 | Short to ground,K solenoid circuit | No | K solenoid operation inhibited |
| 44 | 26 | Short to ground,N solenoid circuit | No | Low and 1st inhibited |
| 45 | 12 | Open circuit,A solenoid circuit | Yes | DNS, SOL OFF (Hydraulic default) |
| 45 | 13 | Open circuit,B solenoid circuit | Yes | DNS, SOL OFF (Hydraulic default) |
| 45 | 14 | Open circuit,C solenoid circuit | Yes | DNS, SOL OFF (Hydraulic default) |
| 45 | 15 | Open circuit,D solenoid circuit | Yes | DNS, SOL OFF (Hydraulic default) |
| 45 | 16 | Open circuit,E solenoid circuit | Yes | DNS, SOL OFF (Hydraulic default) |
| 45 | 21 | Open circuit,F solenoid circuit | No | Lock-up inhibited |
| 45 | 22 | Open circuit,G solenoid circuit | Yes | DNS, SOL OFF (Hydraulic default) |
| 45 | 23 | Open circuit,H solenoid circuit | No | Retarder allowed differential lock inhibited |

TECHNICAL INFORMATION

| MAIN CODE | SUB CODE | DESCRIPTION | DO NOT SHIFT LIGHT | INHIBITED OPERATION DESCRIPTION |
|------------------|-----------------|--|---------------------------|--|
| 45 | 24 | Open circuit,J solenoid circuit | No | Low and 1st inhibited |
| 45 | 25 | Open circuit,K solenoid circuit | No | K solenoid operation inhibited |
| 45 | 26 | Open circuit,N solenoid circuit | No | Low and 1st inhibited |
| 51 | 10 | Offgoing ratio test (during shift), 1 to L | Yes | Low and 1st inhibited |
| 51 | 12 | Offgoing ratio test (during shift), 1 to 2 | Yes | DNS, RPR |
| 51 | 21 | Offgoing ratio test (during shift), 2 to 1 | Yes | DNS, RPR |
| 51 | 23 | Offgoing ratio test (during shift), 2 to 3 | Yes | DNS, RPR |
| 51 | 43 | Offgoing ratio test (during shift), 4 to 3 | Yes | DNS, RPR |
| 51 | 45 | Offgoing ratio test (during shift), 4 to 5 | Yes | DNS, RPR |
| 51 | 65 | Offgoing ratio test (during shift), 6 to 5 | Yes | DNS, RPR |
| 52 | 01 | Offgoing C3PS test (during shift), L to 1 | Yes | DNS, RPR |
| 52 | 08 | Offgoing C3PS test (during shift), L to N1 | Yes | DNS, NNC |
| 52 | 32 | Offgoing C3PS test (during shift), 3 to 2 | Yes | DNS, RPR |
| 52 | 34 | Offgoing C3PS test (during shift), 3 to 4 | Yes | DNS, RPR |
| 52 | 54 | Offgoing C3PS test (during shift), 5 to 4 | Yes | DNS, RPR |
| 52 | 56 | Offgoing C3PS test (during shift), 5 to 6 | Yes | DNS, RPR |
| 52 | 71 | Offgoing C3PS test (during shift), R to 1 | Yes | DNS, NNC |

TECHNICAL INFORMATION

| MAIN CODE | SUB CODE | DESCRIPTION | DO NOT SHIFT LIGHT | INHIBITED OPERATION DESCRIPTION |
|------------------|-----------------|---|---------------------------|--|
| 52 | 72 | Offgoing C3PS test (during shift), R to 2 | Yes | DNS, NNC |
| 52 | 78 | Offgoing C3PS test (during shift), R to N1 | Yes | DNS, NNC |
| 52 | 79 | Offgoing C3PS test (during shift), R to 2 (R to NNC to 2) | Yes | DNS, NNC |
| 52 | 99 | Offgoing C3PS test (during shift), N3 to N2 | Yes | DNS, RPR |
| 53 | 08 | Offgoing speed test (during shift), L to N1 | Yes | DNS, NNC |
| 53 | 18 | Offgoing speed test (during shift), 1 to N1 | Yes | DNS, NNC |
| 53 | 28 | Offgoing speed test (during shift), 2 to N1 | Yes | DNS, NNC |
| 53 | 29 | Offgoing speed test (during shift), 2 to N2 | Yes | DNS, RPR |
| 53 | 38 | Offgoing speed test (during shift), 3 to N1 | Yes | DNS, NNC |
| 53 | 39 | Offgoing speed test (during shift), 3 to N3 | Yes | DNS, RPR |
| 53 | 48 | Offgoing speed test (during shift), 4 to N1 | Yes | DNS, NNC |
| 53 | 49 | Offgoing speed test (during shift), 4 to N3 | Yes | DNS, RPR |
| 53 | 58 | Offgoing speed test (during shift), 5 to N1 | Yes | DNS, NNC |
| 53 | 59 | Offgoing speed test (during shift), 5 to N3 | Yes | DNS, RPR |
| 53 | 68 | Offgoing speed test (during shift), 6 to N1 | Yes | DNS, NNC |
| 53 | 69 | Offgoing speed test (during shift), 6 to N4 | Yes | DNS, RPR |
| 53 | 78 | Offgoing speed test (during shift), | Yes | DNS, NNC |

TECHNICAL INFORMATION

| MAIN CODE | SUB CODE | DESCRIPTION | DO NOT SHIFT LIGHT | INHIBITED OPERATION DESCRIPTION |
|------------------|-----------------|--|---------------------------|---|
| | | R to N1 | | |
| 53 | 99 | Offgoing speed test (during shift), N2 to N3 or N3 to N2 | Yes | DNS, RPR |
| 54 | 01 | Oncoming ratio test (after shift), L to 1 | Yes | DNS, RPR |
| 54 | 07 | Oncoming ratio test (after shift), L to R | Yes | DNS, NNC |
| 54 | 10 | Oncoming ratio test (after shift), 1 to L | Yes | DNS, RPR |
| 54 | 12 | Oncoming ratio test (after shift), 1 to 2 | Yes | DNS, RPR |
| 54 | 17 | Oncoming ratio test (after shift), 1 to R | Yes | DNS, NNC |
| 54 | 21 | Oncoming ratio test (after shift), 2 to 1 | Yes | DNS, RPR |
| 54 | 23 | Oncoming ratio test (after shift), 2 to 3 | Yes | DNS, RPR |
| 54 | 27 | Oncoming ratio test (after shift), 2 to R | Yes | DNS, NNC |
| 54 | 32 | Oncoming ratio test (after shift), 3 to 2 | Yes | DNS, RPR |
| 54 | 34 | Oncoming ratio test (after shift), 3 to 4 | Yes | DNS, RPR |
| 54 | 43 | Oncoming ratio test (after shift), 4 to 3 | Yes | DNS, RPR |
| 54 | 45 | Oncoming ratio test (after shift), 4 to 5 | Yes | DNS, RPR or SOL OFF (Hydraulic default) |
| 54 | 54 | Oncoming ratio test (after shift), 5 to 4 | Yes | DNS,RPR |
| 54 | 56 | Oncoming ratio test (after shift), 5 to 6 | Yes | DNS,RPR |
| 54 | 65 | Oncoming ratio test (after shift), | Yes | DNS,RPR |

TECHNICAL INFORMATION

| MAIN CODE | SUB CODE | DESCRIPTION | DO NOT SHIFT LIGHT | INHIBITED OPERATION DESCRIPTION |
|------------------|-----------------|---|---------------------------|--|
| | | 6 to 5 | | |
| 54 | 70 | Oncoming ratio test (after shift), R to L | Yes | DNS,NNC |
| 54 | 71 | Oncoming ratio test (after shift), R to 1 | Yes | DNS,NNC |
| 54 | 72 | Oncoming ratio test (after shift), R to 2 | Yes | DNS,NNC |
| 54 | 80 | Oncoming ratio test (after shift), N1 to L | Yes | DNS,RPR |
| 54 | 81 | Oncoming ratio test (after shift), N1 to 1 | Yes | DNS,RPR |
| 54 | 82 | Oncoming ratio test (after shift), N1 to 2 | Yes | DNS,RPR |
| 54 | 83 | Oncoming ratio test (after shift), N1 to 3 | Yes | DNS,RPR |
| 54 | 85 | Oncoming ratio test (after shift), N1 to 5 | Yes | DNS,RPR |
| 54 | 86 | Oncoming ratio test (after shift), N1 to 6 | Yes | DNS, RPR |
| 54 | 92 | Oncoming ratio test (after shift), R to 2 (R to NNC to 2) | Yes | DNS, NNC |
| 54 | 92 | Oncoming ratio test (after shift), N1 to 2 (N1 to NNC to 2) | Yes | DNS, RPR |
| 54 | 92 | Oncoming ratio test (after shift), N2 to 2 | Yes | DNS, RPR |
| 54 | 93 | Oncoming ratio test (after shift), N3 to 3 | Yes | DNS, RPR |
| 54 | 95 | Oncoming ratio test (after shift), N3 to 5 | Yes | DNS, RPR |
| 54 | 96 | Oncoming ratio test (after shift), N4 to 6 | Yes | DNS, RPR |
| 54 | 97 | Oncoming ratio test (after shift), 2 to | Yes | DNS, NNC |

TECHNICAL INFORMATION

| MAIN CODE | SUB CODE | DESCRIPTION | DO NOT SHIFT LIGHT | INHIBITED OPERATION DESCRIPTION |
|------------------|-----------------|--|---------------------------|--|
| | | R (2 to NNC to R) | | |
| 55 | 17 | Oncoming C3PS test (after shift), 1 to R | Yes | DNS, NNC |
| 55 | 27 | Oncoming C3PS test (after shift), 2 to R | Yes | DNS, NNC |
| 55 | 80 | Oncoming C3PS test (after shift), N1 to L | Yes | DNS, RPR |
| 55 | 87 | Oncoming C3PS test (after shift), N1 to R | Yes | DNS, RPR |
| 55 | 97 | Oncoming C3PS test (after shift), 2 to R or NVL to R (2 to NNC to R) | Yes | DNS, NNC |
| 56 | 00 | Range verification test, L | Yes | DNS, 1st, Low, or SOL OFF (Low) |
| 56 | 11 | Range verification test, 1st | Yes | DNS, 6th |
| 56 | 22 | Range verification test, 2nd | Yes | DNS, 6th or 5th |
| 56 | 33 | Range verification test, 3rd | Yes | DNS, 5th or SOL |
| 56 | 44 | Range verification test, 4th | Yes | DNS, 3rd or 5th |
| 56 | 55 | Range verification test, 5th | Yes | DNS, SOL OFF (5th) or 3rd |
| 56 | 66 | Range verification test, 6th | Yes | DNS, 5th, 3rd, or SOL OFF (3rd) |
| 56 | 77 | Range verification test, R | Yes | DNS, N2 or N3 |
| 57 | 11 | Range verification C3PS test, 1st | Yes | DNS, SOL OFF (3rd) |
| 57 | 22 | Range verification C3PS test, 2nd | Yes | DNS, 3rd |
| 57 | 44 | Range verification C3PS test, 4th | Yes | DNS, 5th or SOL OFF (3rd) |
| 57 | 66 | Range verification C3PS test, 6th | Yes | SOL OFF (5th), DNS |
| 57 | 88 | Range verification C3PS test, N1 | Yes | DNS, N3 |
| 57 | 99 | Range verification C3PS test, N2 or N4 | Yes | DNS, N3 |
| 61 | 00 | Retarder oil temperature, hot | No | None |
| 62 | 12 | Retarder oil temperature sensor, low | No | None |

TECHNICAL INFORMATION

| MAIN CODE | SUB CODE | DESCRIPTION | DO NOT SHIFT LIGHT | INHIBITED OPERATION DESCRIPTION |
|------------------|-----------------|--|---------------------------|--|
| 62 | 23 | Retarder oil temperature sensor, high | No | None |
| 63 | 00 | Special function input | No | Depends on special function |
| 64 | 12 | Retarder modulation request sensor, low | No | Retarder operation inhibited |
| 64 | 23 | Retarder modulation request sensor, high | No | Retarder operation inhibited |
| 65 | 00 | Engine rating too high | Yes | DNS |
| 66 | 00 | Serial communications interface fault | No | Use default throttle values |
| 69 | 12 | ECU, A solenoid driver open | Yes | DNS, SOL OFF (hydraulic default) |
| 69 | 13 | ECU, B solenoid driver open | Yes | DNS, SOL OFF (hydraulic default) |
| 69 | 14 | ECU, C solenoid driver open | Yes | DNS, SOL OFF (hydraulic default) |
| 69 | 15 | ECU, D solenoid driver open | Yes | DNS, SOL OFF (hydraulic default) |
| 69 | 16 | ECU, E solenoid driver open | Yes | DNS, SOL OFF (hydraulic default) |
| 69 | 21 | ECU, F solenoid driver open | No | Lock-up inhibited |
| 69 | 22 | ECU, G solenoid driver open | Yes | DNS, SOL OFF (Hydraulic default) |
| 69 | 23 | ECU, H solenoid driver open | No | Retarder allowed, differential lock inhibited |
| 69 | 24 | ECU, J solenoid driver open | No | Low and 1 st inhibited |
| 69 | 25 | ECU, K solenoid driver open | No | K solenoid operation inhibited |
| 69 | 26 | ECU, N solenoid driver open | No | Low and 1st inhibited |
| 69 | 32 | ECU, SPI communications link fault | No | Hold in last valid direction |
| 69 | 33 | ECU, Central Operating Processor (COP) timeout | Yes | Reset ECU, Shutdown ECU on 2nd occurrence (power |

TECHNICAL INFORMATION

| MAIN CODE | SUB CODE | DESCRIPTION | DO NOT SHIFT LIGHT | INHIBITED OPERATION DESCRIPTION |
|-----------|----------|---|--------------------|-------------------------------------|
| | | | | loss: hydraulic defaults) |
| 69 | 34 | ECU, EEPROM write timeout | Yes | DNS, SOL OFF (Hydraulic default) |
| 69 | 35 | ECU, EEPROM checksum | Yes | Induce COP timeout (reset ECU) |
| 69 | 36 | ECU, RAM self test | Yes | Induce COP timeout (reset ECU) |
| 69 | 41 | ECU, I/O ASIC addressing test | Yes | Induce COP timeout (reset ECU) |
| 70 | 12 | Software, minor loop overrun | Yes | Induce COP timeout (reset ECU) |
| 70 | 13 | Software, illegal write to address \$0000 | Yes | Induce COP timeout (reset ECU) |
| 70 | 14 | Software, major loop overrun | Yes | Induce COP timeout (reset ECU) |

| LIGHT BULB DATA | | | | | | |
|-------------------------------------|------------------|---------------------|-----------------------|-------|-----------|-----------|
| APPLICATION | PREVOST PART NO. | TRADE OR SAE NUMBER | WATTS OR CANDLE POWER | VOLTS | QTY XL-40 | QTY XL-45 |
| EXTERIOR LIGHTING | | | | | | |
| Headlight Hi/Lo | 930291 | 9004 | 65 W/45 W | 12 | 2 | 2 |
| Fog (Optional) | 561882 | H3(Osram) | 55 W | 12 | 2 | 2 |
| License plate (sealed) | 930266 | --- | 12 W | 12 | 2 | 2 |
| Side directional | 561917 | 1893 | 2 cp | 12 | 12 | 12 |
| Side marker | 561917 | 1893 | 2 cp | 12 | 12 | 12 |
| Identification | 562059 | 194 | 2 cp | 12 | 6 | 6 |
| Clearance | 562059 | 194 | 2 cp | 12 | 8 | 8 |
| Front directional (hazard & marker) | 562135 | 3057 | 32/3 cp | 12 | 2 | 2 |

TECHNICAL INFORMATION

| LIGHT BULB DATA | | | | | | |
|---|-----------------------------|--------------------------------|--------------------------------------|--------------|----------------------|----------------------|
| APPLICATION | PREVOST PART NO. | TRADE OR SAE NUMBER | WATTS OR CANDLE POWER | VOLTS | QTY XL-40 | QTY XL-45 |
| Rear directional | 560589 | 1156 | 32 cp | 12 | 8 | 8 |
| Stop | 560589 | 1156 | 32 cp | 12 | 8 | 8 |
| Back-up | 560589 | 1156 | 32 cp | 12 | 4 | 4 |
| Center stop | 560589 | 1156 | 32 cp | 12 | 2 | 2 |
| Tail | 560123 | 67 | 4 cp | 12 | 8 | 8 |
| Exterior compartment (except engine) | 562278 | 6429 (78207) | 10 W | 24 | 12 | 12 |
| Engine compartment | 560601 | 456 | 2 cp | 24 | 8 | 6 |
| INTERIOR LIGHTING | | | | | | |
| Check engine | 562048 | E-9 (Norma) | 2 W | 12 | 1 | 1 |
| Stop engine | 562048 | E-9 (Norma) | 2 W | 12 | 1 | 1 |
| Flasher indicator | 562048 | E-9 (Norma) | 2 W | 12 | 2 | 2 |
| Other indicator - 1/unit | 562049 | (Osram) | 2 W | 24 | AR | AR |
| Speedometer | 560145 | 1829 | 1 cp | 24 | 2 | 2 |
| Pyrometer (Opt) | 560601 | 456 | 2 W | 24 | 1 | 1 |
| Tachometer | 560145 | 1829 | 1 cp | 24 | 2 | 2 |
| Turbo boost (Opt) | 561167 | 3899 (Osram) | 3 W | 24 | 1 | 1 |
| Tachograph (Opt) | 561006 | 1-405-804 | 1.2 cp | 24 | 3 | 3 |
| Other instrument - 1/unit | 560144 | 1820 | 1.6 cp | 24 | AR | AR |
| Step | 562278 | 6429 (78207) | 10 W | 24 | 3 | 3 |
| Driver's area | 561553 | 78236 | 10 W | 24 | 4 | 4 |
| Lavatory | 561553 | 78236 | 10 W | 24 | 2 | 2 |
| Lavatory night light | 560601 | 456 | 2 cp | 24 | 2 | 1 |
| Lavatory "Occupied" | 560702 | 1843 | 0.2 cp | 24 | 2 | 2 |
| Parcel racks | 560144 | 1820 | 1.6 cp | 24 | 14 | 12 |

| LIGHT BULB DATA | | | | | | |
|------------------------|------------------|---------------------|-----------------------|-------|-----------|-----------|
| APPLICATION | PREVOST PART NO. | TRADE OR SAE NUMBER | WATTS OR CANDLE POWER | VOLTS | QTY XL-40 | QTY XL-45 |
| "Emergency exit" | 560601 | 456 | 2 cp | 24 | 20 | 14 |
| Aisle | 560141 | 1251 | 3 cp | 24 | 7 | 6 |
| Switch 1/unit | 561123 | 2741 (Osram) | 1 W | 24 | AR | AR |
| Reading | 562033 | 961-4940 | 8 W | 24 | AR | AR |
| Fluorescent | 830102 | F15T8 CW | 15 W | --- | 27 | 21 |
| Destination sign | 560125 | 16911F | 15 W | 24 | 4 | 4 |
| Parcel rack front neon | 830108 | PL7 | 7 W | --- | 16 | 14 |
| Rear roof | 561553 | 78236 | 10 W | 24 | 2 | 2 |
| R.H. lateral console | 562278 | 6429 (78207) | 10 W | 24 | 1 | 1 |

DATA PLATE & CERTIFICATION

Data plate

The main components of the vehicle such as engine, transmission, axles and chassis are identified by different serial numbers. It may be necessary to locate these numbers for warranty purposes.

Engine

The engine serial number is stamped on the cylinder block under the exhaust manifold (oil filter side) close to the water pump.

In addition, four plates are located on the rocker cover (oil filter side). Contents of the plates include the engine serial and model numbers and a list of the optional equipment on the engine. The information is primarily used when ordering replacement parts.

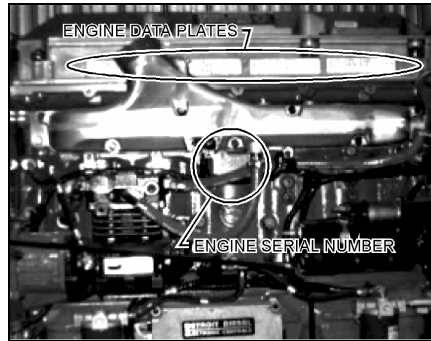

01012

Transmission

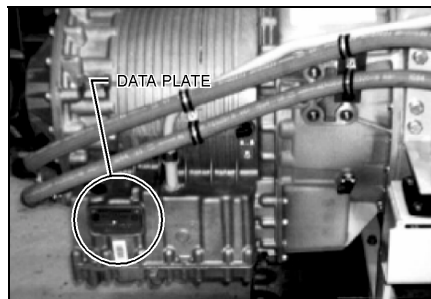

07003

TECHNICAL INFORMATION

Drive axle

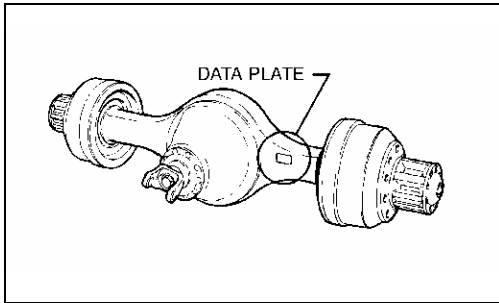

11004

Front axle

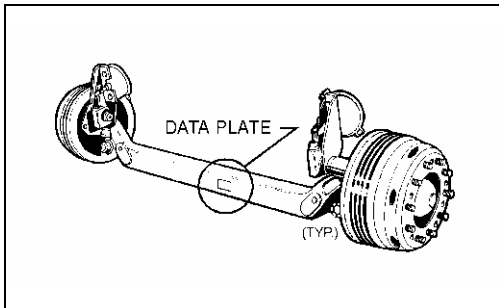

10003

Vehicle identification number (V.I.N.)

The vehicle identification number is stamped on a plate located on dashboard louver (entrance door side), so that it is visible from the outside through the windshield. It is extremely important to give the correct vehicle identification number when ordering replacement parts. Use of these numbers will prevent delay and errors in obtaining the correct material.

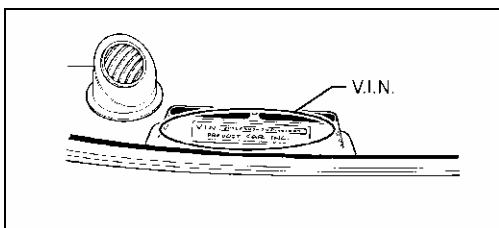

18041

Coach final record

This is a complete and detailed record of all data pertaining to the assembly of the vehicle. This information sheet is included in the technical publication box delivered with the new vehicle and should be kept in vehicle where it will be readily available for reference.

Safety attestation

All the components on this vehicle meet the government requirements:

- Material and parts conform to ASTM and/or SAE standards in effect at time of manufacturing.
- Welding is in accordance with Canadian and US standards.
- All factory-installed interior materials meet F.M.V.S.S. 302 on fire resistance.
- Certified according to Provincial, State and Federal Safety standards (Can. & US) B.M.C.S.S., F.M.V.S.S., C.M.V.S.S.

Other certification labels are affixed to the specific components on the vehicle.

DOT certification label

This is your assurance that your new vehicle complies with all applicable Federal Motor Vehicle Safety Standards which were in effect at the time the vehicle was manufactured. You can find this label affixed below L.H. Side Control Panel in driver's compartment.

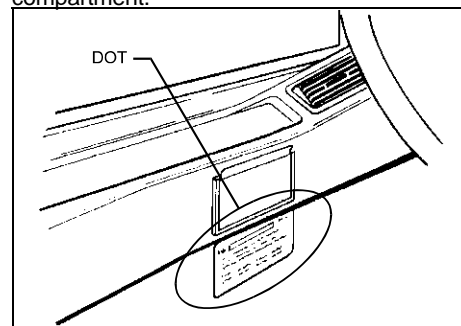

18042

EPA engine label

The exhaust emission certification label affixed on the lower R.H. side corner of the rear junction box certifies that the engine conforms to federal and any state exhaust emission regulations. It gives the operating conditions at which certification was made.

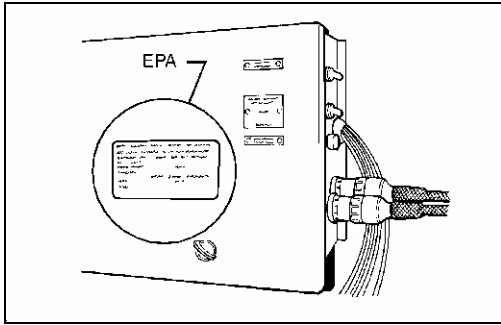

01011

Fuel tank label

The fuel tank label is affixed on side of fuel tank. To read this label, open the last baggage compartment door, locate the fuel tank access panel then remove it by unscrewing the Phillips head retaining screws.

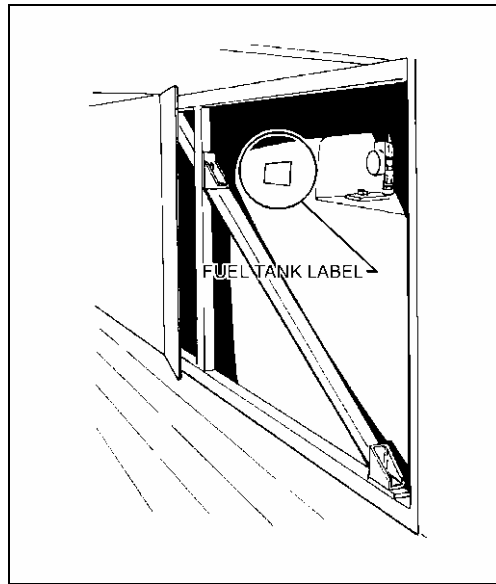

03003

NOTE: *Optional auxiliary fuel tank has a label affixed to the side of the tank and can be easily read by opening the second baggage compartment door.*



03002

NOTE: *It is strongly recommended that you take note of all the serial numbers on the vehicle and supply them to your insurance company. They may be useful.*

TABLE OF CONTENTS

STARTING AND STOPPING

PROCEDURES 4 - 1

| | |
|--|--------|
| General information..... | 4 - 1 |
| Detroit Diesel Electronic Control (DDEC)..... | 4 - 3 |
| World Transmission WT Electronic Control System..... | 4 - 4 |
| Manual transmission..... | 4 - 8 |
| Cold weather starting..... | 4 - 8 |
| Daily inspection..... | 4 - 9 |
| Recommendations..... | 4 - 10 |
| Heating and air conditioning..... | 4 - 11 |
| Preheating systems..... | 4 - 14 |
| Windshield washer reservoir..... | 4 - 15 |
| Jump starting..... | 4 - 16 |
| Electric circuit protection..... | 4 - 17 |
| Tires..... | 4 - 18 |
| Towing..... | 4 - 20 |
| Jacking points..... | 4 - 21 |
| Retractable tag axle..... | 4 - 21 |
| Tag axle unloaded..... | 4 - 21 |

TECHNICAL INFORMATION 5 - 1

| | |
|------------------------|-------|
| Dimensions..... | 5 - 1 |
| Weights..... | 5 - 2 |
| Capacities..... | 5 - 2 |
| Fuel type..... | 5 - 2 |
| Wheels and tires..... | 5 - 2 |
| Belts..... | 5 - 3 |
| Engines..... | 5 - 3 |
| Transmissions..... | 5 - 3 |
| Drive axle ratio..... | 5 - 3 |
| Brakes..... | 5 - 4 |
| Steering..... | 5 - 4 |
| Electrical system..... | 5 - 4 |
| Sound system..... | 5 - 4 |
| Video system..... | 5 - 4 |
| Suspension..... | 5 - 4 |

| | |
|---|--------|
| Alignment..... | 5 - 5 |
| Heating and air conditioning..... | 5 - 5 |
| Oil specifications..... | 5 - 5 |
| Antilock braking system (ABS)..... | 5 - 6 |
| Preheating systems..... | 5 - 6 |
| Storage volume..... | 5 - 6 |
| Seats..... | 5 - 7 |
| DDEC III diagnostic codes..... | 5 - 7 |
| World transmission WT diagnostic codes..... | 5 - 10 |
| Light bulb data..... | 5 - 25 |
| Data plate and certification..... | 5 - 27 |

CARE AND MAINTENANCE 6 - 1

| | |
|---|--------|
| Interior cleaning..... | 6 - 1 |
| Exterior cleaning..... | 6 - 3 |
| Oil verification..... | 6 - 4 |
| Air tanks..... | 6 - 7 |
| Coolant level verification..... | 6 - 8 |
| Water separator..... | 6 - 8 |
| Belt tensioners..... | 6 - 8 |
| A/C and heating air filters..... | 6 - 10 |
| Flexible hose maintenance..... | 6 - 10 |
| Lubrication..... | 6 - 11 |
| Fire extinguishers..... | 6 - 11 |
| 110-120 volt in-station lighting..... | 6 - 11 |
| 110-120 volt in-station connectors..... | 6 - 11 |
| Back-up camera..... | 6 - 12 |
| Filter restriction indicator..... | 6 - 12 |
| Lavatory maintenance..... | 6 - 12 |
| First service on new vehicle..... | 6 - 14 |
| Lubrication and servicing schedule..... | 6 - 15 |

SERVICE LITERATURE 7 - 1

PREVOST**XL Series Motorcoach
CARE & MAINTENANCE****INTERIOR CLEANING**

To provide consistent and quality passenger service, the coach interior must be kept clean at all times. Scheduled servicing of the coach shall include cleaning of all passenger areas.

NOTE: Use only approved cleaning products obtained through a recognized cleaning product supplier. Never use stain protection products on new fabrics. To prevent permanent staining of fabrics, clean stains soon after they occur. Incorrect treatment of stains can worsen them. Get help from a cleaning specialist to remove stubborn stains.

NOTE: The cleaning information provided in this section are recommended cleaning practices. Cleaning results may vary depending on the condition of the stain. Always clean stain promptly for best results.

Seat Upholstery**Normal Cleaning**

Firmly beat the seat upholstery with a blunt object, such as a wooden paddle, to release dust and dirt. Vacuum the seat upholstery fabric in the direction of the stitching using an upholstery nozzle.

NOTE: Upholstery life will be reduced due to the abrasive nature of dirt and grit. Vacuum the seat upholstery regularly.

Removal of Stains and Marks

Remove stains and marks from the wool plush as follows:

Method 1

- Apply a nonflammable solvent (Trichloroethylene) to stained area with a clean, white absorbent rag.
- Clean stain by starting at the outer edges of the stain and working in toward the center.
- Blot affected area frequently with a clean, dry absorbent cloth to prevent stain rings caused by excess solvent.

WARNING: Use solvents in a well ventilated area. Open all windows and doors.

Method 2

- Wet the stain with a solution of household detergent and lukewarm water. Do not soak the stain.
- Rub the stain with a damp cloth.
- Rinse cloth after each application.

CAUTION: Do not use soap, soap powder, ammonia, soda, bleach or cleaning products containing any of these compounds.

Beverage Stains

Remove beverage stains by following method 1. If stain persists, repeat method 1 using methylated spirits instead of solvent.

Alcoholic Beverage Stains

Remove alcoholic beverage stains by wetting the stain with water, then clean following method 2.

Burns

Scrape burnt area using a knife or razor blade then clean following method 2. Consult an upholstering specialist when dealing with extensive burns.

Cosmetic Stains

Remove stains left by cosmetics by following method 1 then method 2.

Ink Stains

Remove ink stains following method 2. If stain persists, apply a warm oxalic acid solution. Rinse with water.

Blood stains

Remove blood stains following method 2.

Urine

Remove urine stains following method 2.

Vomit

Remove vomit stains following method 2.

Copying Ink - Ballpoint Pen Ink

Treat with methylated spirits, blotting frequently to avoid spreading stain, followed by method 2.

Marking Ink (Felt-Tip Pens)

Treat with Methyl-Ethyl-Ketone (MEK) followed by method 2.

Oil, Grease and Paint

Remove excess using a knife. Treat with method 1 followed by method 2. If stain persists, repeat procedure.

Rust

Remove rust stains by following method 2. Apply a warm oxalic acid solution to stained areas. Rinse with water.

Tar

Soften Tar with benzene and then treat using method 1 followed by method 2.

Chewing Gum

Soften gum with cyclohexane. Carefully scrape off stains using a sharp knife or razor blade.

Plastic and vinyl

Use a clean, damp cloth or sponge to keep trim free from dust. For other soilage, use a lukewarm all purpose cleaning solution or a mild saddle soap for vinyl trim. Remove water spots and soap traces with a clean, damp cloth or sponge. Use a clean, soft cloth to rub dry.

Grease, tar or oil stains can be removed with a clean cloth or sponge soaked with an all purpose cleaner or with a solvent-type vinyl cleaning agent.

Occasionally, apply a colorless vinyl or leather preservative to retain the material's luster and pliability.

Windows

To clean inside surface of the windows, use a commercial glass cleaner or a 10 to 1 mix of water and white vinegar. For maximum visibility, keep your windows clean at all times.

Rubber components

Should be treated only with pure water or glycerin.

Pressure laminates

Normal maintenance consists in wiping surfaces with a damp cloth and detergent. Remove spillage at once to avoid permanent stains.

To remove stains, first try cleaning the affected area with a household detergent, methylated spirits or mineral turpentine. If stain is still present, try a mild abrasive and water solution.

Stainless steel

Use a stainless steel cleaner available at any automotive washing and cleaning specialist and follow manufacturer's instructions.

Formica

Remove stains on formica surfaces with a household detergent, methylated spirits or mineral turps. Clean with a mild abrasive and water solution if stains persist.

Carpet

Vacuum carpets regularly to prolong carpet life.

Floor cleaning

Clean floors with a quality nonionic detergent cleaner. Follow the manufacturer's recommendations for cleaning.

Remove any excess detergent solution using a wet/dry vacuum or mop. Rinse floor with a solution of one part Clorox to ten parts warm water.

Polish dry floor using a high-speed buffer and a smooth, red 3-M polishing pad.

Mop floor periodically with a solution of 5% Clorox in warm water.

EXTERIOR CLEANING

The paint on your vehicle is very durable, but must be protected from harsh weather conditions that can make it lose its luster. Therefore, wash and wax your vehicle often. The longer the dirt is left on the paint, the greater the risk of damaging the glossy finish; either by scratching (if the dirt is rubbed into the paint), or simply by the chemical effect dirt particles have on painted surfaces.

Begin by spraying water over the entire vehicle to remove all loose dirt, then wash with a car washing-soap in the concentration recommended by the manufacturer. Rinse afterwards with a generous stream of water.

NOTE: *The vehicle paintwork needs polishing or preserving when water no longer forms droplets on the surface.*

CAUTION: *Do not use hot water. Lukewarm to cool water is less harmful to the paint. Do not use solutions that can damage the body paint.*

Do not aim the water jet directly into openings such as the A/C & heating compartment door grille to avoid water penetration in the fresh air intake duct. If the water jet is under high pressure, avoid aiming the jet directly on condenser and radiator doors as the fins of cores may be damaged. Do not wash or wax your vehicle in direct sunlight.

The underside of the vehicle picks up dirt and road salt used to keep streets and highways free of snow and ice. To protect against corrosion, it is important to remove mud, debris and road salt from the underside with a powerful water jet. Be sure to include the wheelhousings, bumpers, muffler, tailpipe and brackets. This should be done twice a year and is best accomplished after the vehicle has been driven through a heavy rain. The exterior of the vehicle, engine, engine compartment, aluminum wheels and mirrors should always be washed as soon as possible after accumulating road salt.

NOTE: *Let engine and exhaust cool down before washing.*

Tar or oil

Do not allow tar or oil to remain on the paint. Remove as soon as possible with tar remover or turpentine. After applying cleaning fluids, always wash with a lukewarm water and soap solution, then apply a new coat of wax.

Insects

Remove as soon as possible with a lukewarm water and soap solution or insect remover.

Tree sap

Do not allow tree sap or bird droppings to harden on the paint. Remove with a lukewarm water and soap solution.

Windows

Keep silicone sprays off the windshield to avoid wiper smear in rain. Clean all windows regularly to remove road film and bus-wash wax buildup. Use a lukewarm soap and water solution or an alcohol-based cleaning agent. If a chamois is used for polishing the glass, it should be used exclusively for that purpose.

Wiper blades

If wiper blades are frozen, remove ice gently by hand to avoid blade damage. Remove all wiper blades periodically and clean them thoroughly with an alcohol-based solution. Use a sponge or soft cloth and wipe lengthwise. Replace wiper blades if they are damaged or do not clean well.

OIL VERIFICATION

Engine oil level

Ideally, check engine oil level when oil is warm with vehicle on a level surface; for instance, during every fuel filling. First, stop engine and wait at least 10 minutes for the oil to drain back into the oil pan. Then, pull out the dipstick, wipe clean, reinsert the dipstick and note the oil level. Maintain the oil level between the two marks on the dipstick, and never allow it to drop below the "L" mark. If required, add oil from the oil reserve tank by opening the tank valve and observing the oil level change in the sight glass, then check oil level again. No advantage is gained by having oil level above the "F" mark. Do not forget to shut off oil reserve tank valve as too much oil can be harmful to the engine.

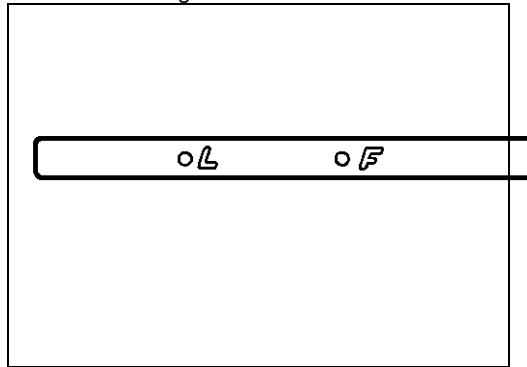

01016

NOTE: *For location of engine oil dipstick and engine oil reserve tank see figure on page 2-34.*

Automatic transmission oil level
Manual oil level check procedure

NOTE: For "Electronic Readout of Oil level sensor" and other transmission related information, see pages 4-4 through 4-8.

WARNING: When checking the oil level, be sure that the transmission is in Neutral, parking brake is properly engaged, and the wheels are chocked. Unexpected and possible sudden vehicle movement may occur if these precautions are not taken.

Special care must be taken not to touch the engine coolant tubing and/or exhaust pipe, as this could cause severe burns.

Do not wear loose clothing and stay away from rotating parts during procedure. Personal injury could occur.

NOTE: Clean around the end of fill tube before removing dipstick. This will aid in preventing dirt and/or foreign matter from entering the fluid system, which can cause valves to stick, undue wear of transmission parts, or clog passages.

Cold Check

The purpose of the Cold Check is to determine if the transmission has enough fluid to be operated safely until a Hot Check can be made.

If the engine has been shut down for an extended period of time, park the vehicle on a level surface and apply the parking brake.

Run the engine for at least 1 minute. Shift to Drive and operate the engine for 30 seconds at 1000-1500 rpm; then shift to Reverse to clear the hydraulic system of air. Then shift to Neutral and allow the engine to idle (500-800 rpm).

After wiping the dipstick clean (see page 2-34 for dipstick location), check the fluid level. If the fluid on the dipstick is within the COLD RUN band, the level is satisfactory. If the fluid level is not within this band, add or drain fluid as necessary to bring the level to the COLD RUN band.

Perform a HOT CHECK at the first opportunity after normal operating temperature (71°C-93°C; 160°F-200°F) is reached.

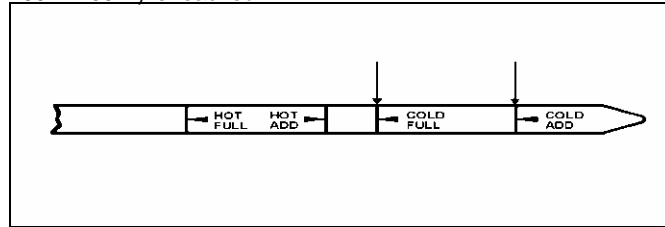

07006

CAUTION: An accurate fluid level check cannot be made unless the engine is idling (500-800 rpm) in Neutral, the transmission fluid is at the proper temperature, and the vehicle is on a level surface.

Hot Check

Because the fluid level rises as temperature increases, the fluid must be hot to ensure an accurate check.

Be sure fluid has reached normal operating temperature (71°C-93°C; 160°F-200°F).

Park the vehicle on a level surface and shift to Neutral. Apply parking brake and allow the engine to idle (500-800 rpm).

After wiping the dipstick clean, check the fluid level. The safe operating level is anywhere within the HOT RUN band on the dipstick.

If the level is not within this band, add or drain fluid as necessary to bring the level within the HOT RUN band.

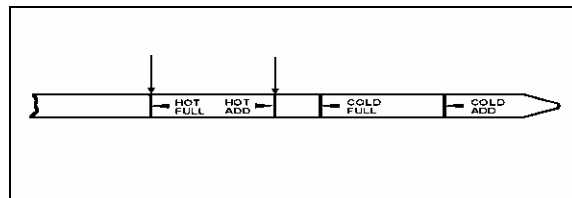

07007

**Manual transmission oil level
(6 speed & 7 speed)**

Oil check

Manual transmission oil should be checked with engine stopped and cold.

WARNING: Before servicing the coach, park safely over a repair pit, apply parking brake, stop engine and set main battery disconnect switch (XL-40) or battery master switch (XL-45) to the "OFF" position.

Unscrew the fill plug and check if the oil level is at the plug thread level.

Refill

Refill manual transmission oil as follows:

- Remove fill plug.
- Add oil until it overflows.
- Clean oil from the transmission case and the fill plug.
- Replace fill plug.

Clutch pedal master cylinder fluid level

Maintain the clutch pedal master cylinder fluid level at the reservoir seam. The fluid reservoir is located under the dashboard near the clutch pedal.

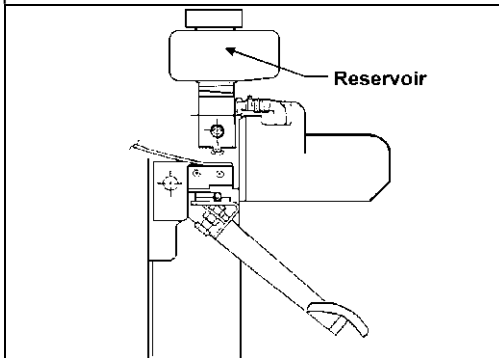

07009

Power steering oil level

Your vehicle is equipped with an integrated power steering system. The power steering fluid reservoir is located on the upper R.H. side of engine in the engine compartment (see page 2-34). To check fluid level, proceed as follows:

1. Stop engine, and open both engine rear doors.
2. Remove dipstick and wipe with a clean rag.
3. Insert dipstick in reservoir, then remove it again to check mark.
4. Adjust level to "FULL" mark, using only "DEXRON IIE or III" automatic transmission fluid.

Fan gearbox oil level

The radiator fan is belt driven from the engine crankshaft pulley through a drive shaft and a gearbox (for location of gearbox, see page 2-34). The gearbox is equipped with an Oil Level Plug and a Drain Plug. Check oil level with the engine stopped and make sure that all engine stopping safety precautions have been observed. Oil level is correct when oil seeps out of loosened Oil Level Plug; if adding is necessary, use Mobil SHC 634 Synthetic lubricant.

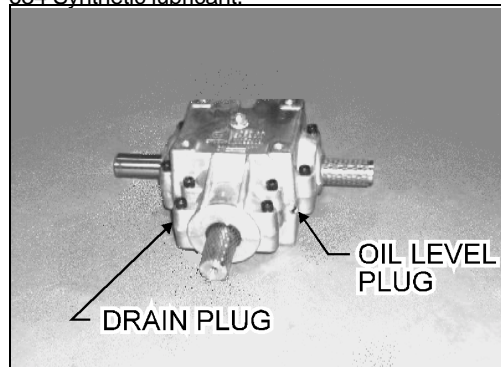

05008

A/C compressor

The level is acceptable when oil is visible in the sight glass on R.H. side of compressor. For an

accurate reading, release tension on belt, then level compressor. The oil level should be in center of sight glass. (see A/C compressor location on page 2-34).

Wheel bearing oil level

The oil level for the front and tag axle wheel bearings must be maintained to the level mark in the cap. The level is determined by a line, indicated by arrows, that is incorporated to the plastic lens and passes underneath the words "OIL LEVEL". To check oil level after vehicle has been driven, wait at least 15 minutes to ensure that oil has settled. Drive axle wheel bearings are lubricated by the differential oil. Maintain differential oil level to ensure adequate lubrication of drive axle wheel bearings at all times.

On vehicles equipped with grease-lubricated wheel bearings, pack with wheel bearing grease.

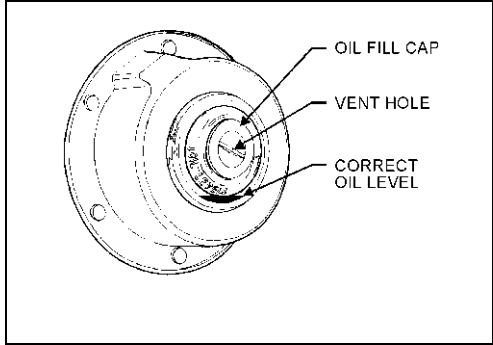

13003

CAUTION: Wheel bearing oil fill cap is supplied with a very small vent hole in its center. Occasionally insert a small tip (toothpick size) to be sure that hole is not plugged; a plugged hole may cause leakage when heat expands the oil and air.

AIR TANKS

Your vehicle is equipped with four (4) air tanks; the accessory tank and wet tank must be purged before every trip or once a month, while the primary and secondary air tanks must be purged each time the oil and filters are changed (maximum 10,000 miles (16 000 km)).

The accessory air tank is installed above front axle and its remote drain valve is located in Steering Compartment.



12014

The wet air tank is installed above L.H. wheel of drive axle and its remote drain valve is located in engine compartment and is accessible through engine R.H. side door. On **XL-40** valve is located below air filter and on **XL-45** valve is located below emergency fill valve.

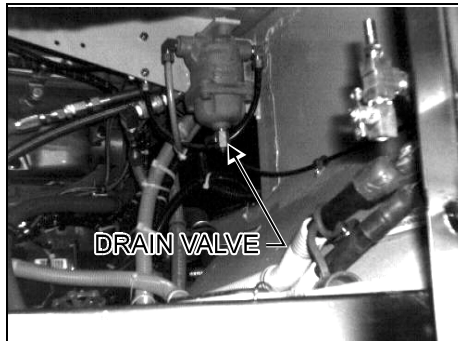

XL-40

12058

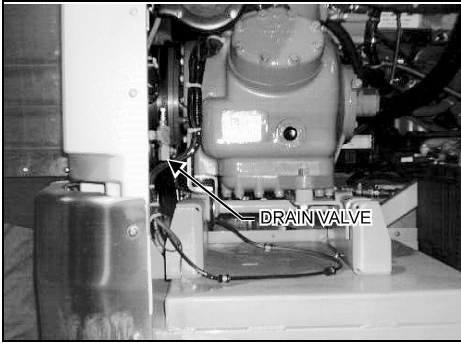

XL-45

12016

All four (4) tanks installed under the vehicle, are supplied with a drain valve underneath the tank. For locations, refer to figure in "Lubrication and servicing schedule" later on in this section.

COOLANT LEVEL VERIFICATION

The cooling system is completely filled when the coolant (cold) is visible in the sight glass of the surge tank (see page 2-34 for location). If topping-up is necessary, fill the system with the same mixture ratio already used in the system.

WARNING: Hot engine coolant is under pressure. Never remove cap when coolant is hot as severe burns can result. Allow engine to cool before checking coolant level.

WATER SEPARATOR (Optional)

A fuel filter/water separator may be installed in engine's primary fuel filter location, in engine compartment, to prevent water infiltration in engine fuel system. It should be drained periodically, or when the water separator indicator lamp lights in dashboard. To drain, loosen self venting drain below separator, and tighten after water has been flushed out.

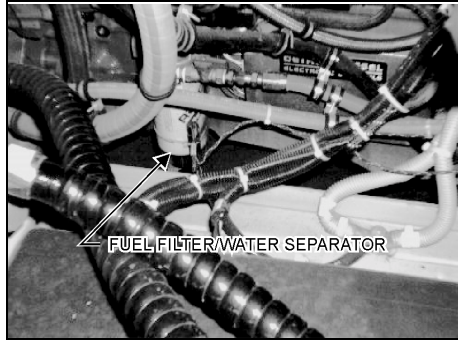

03004

BELT TENSIONERS

Air-operated type

Belt tensioning is applied through air bellows which are adjusted by an air pressure regulating valve mounted in engine compartment above the doors. For proper operation of the air bellows, adjust the upper tensioning bracket to provide a 2 3/8"-2 1/2" (60-64mm) extension with the pneumatic system under normal pressure and the pressure regulating valve set at 50 psi (345 kPa) for Series 60 engines and at 70 psi (482 kPa) for Series 50 engines.

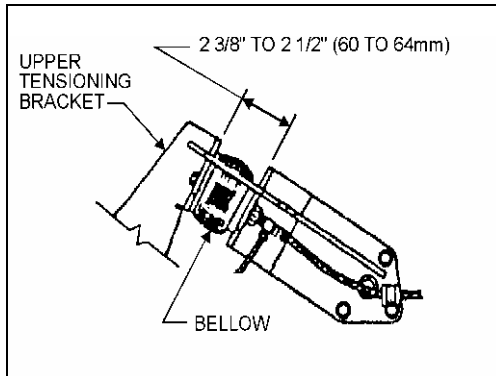

12017

For belt replacement, air pressure must be released from bellows by means of the belt tensioning pressure control valve. This valve (see page 2-34) mounted above the engine doors close to the pressure regulating valve, is manually operated. Before handling, be sure that all engine stopping safety precautions have been observed.

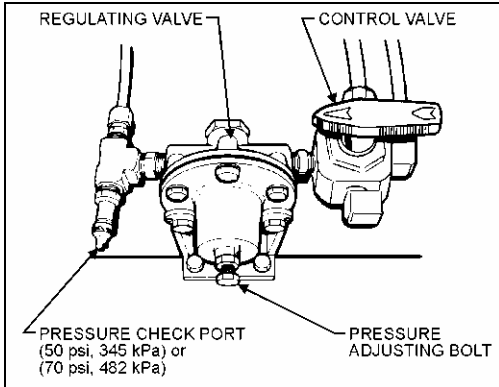

12018

Manually adjustable type

There are two (2) different types of manually adjustable belt tensioning systems. Tension belts according to the instructions in "Maintenance Manual".

A/C AND HEATING AIR FILTERS

For maximum air conditioning and heating system efficiency, air filters should be inspected and cleaned as required in maintenance schedule to ensure proper ventilation of the evaporator and heating radiator cores.

Driver's system

Air filter for driver's system is located under dashboard. To gain access, turn counterclockwise both 3/4 turn knurled fasteners of A/C and heating unit access panel, then lift and remove panel.

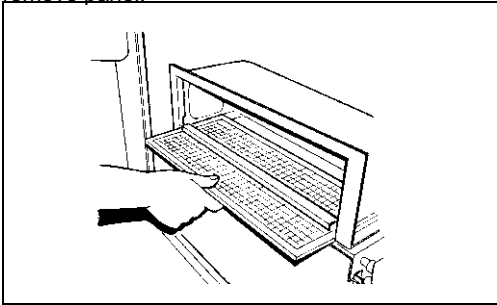

22011

Central system

The central system uses two (2) air filters. On **XL-40** (prior to V.I.N. 2P9L33496S1001570), filters are located in the A/C and heating compartment. To gain access, open the rear baggage compartment door, open the air filter access panel by unscrewing the three (3) retaining screws, then slide out both filters as a unit.

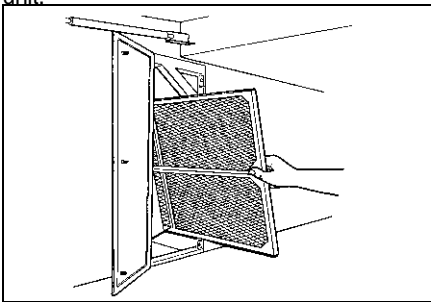

22012

On **XL-40** (starting with V.I.N. 2P9L33496S1001570) and all **XL-45** vehicles, the two (2) filters are located in A/C and heating compartment. To gain access, open driver's side baggage compartment, forward of A/C and heating compartment, and open the air filter access panel by unscrewing the three (3) retaining screws. Slide out the upper filter first, then slide out the other.

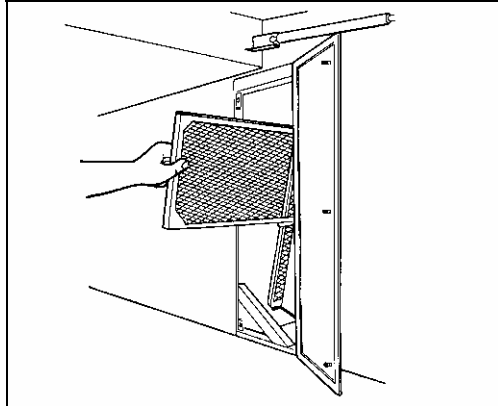

22012B

FLEXIBLE HOSE MAINTENANCE

The performance of engine and related equipment is greatly affected by the flexible hoses' ability to carry fluids or gases. Maintenance of hoses is an important element in ensuring efficient, economical, and safe operation of your vehicle.

Pre-starting inspection

Inspect hoses for leaks, and check all fittings, clamps, and ties carefully. Ensure that hoses are not resting on or touching shafts, couplings, heated surfaces including exhaust manifolds, any sharp edges, or other obviously damaging areas.

Since all machinery vibrates and moves to a certain extent, clamps and ties can fatigue with time. To ensure proper support, inspect fasteners frequently and tighten or replace them as necessary.

Leaks

Investigate leaks immediately to determine if fittings have loosened or cracked, and also if

hoses have ruptured or worn through. Take corrective action immediately. Leaks are not only potentially detrimental to machine operation, but can also result in added expenses caused by the need to replace lost fluids.

WARNING: *Personal injury and/or property damage may result from fire due to the leakage of flammable fluids, such as fuel or lubricating oil.*

Service life

A hose has a limited service life which is controlled by many factors. With this in mind, it is recommended that all hoses be thoroughly inspected annually. Look for surface damage or indications of twisted, worn, crimped, brittle, cracked, or leaking lines. Hoses having the outer surface worn through or a damaged metal reinforcement should be considered unfit for further service.

It is also recommended that all hoses in this vehicle be replaced during major overhaul and/or after a maximum of five service years. Replacement hoses and hardware should always be at least equal in quality to that of the O.E.M..

LUBRICATION

A lubrication chart is provided in this section to give locations of key service points on the vehicle. Cleaning, removal or disassembly procedures (required for lubrication purposes) are covered in the applicable sections of this manual.

Lubrication intervals are based on recommendations for normal operating conditions. Where more severe service is encountered, more frequent attention will be required.

FIRE EXTINGUISHERS

In order for fire extinguishers to operate adequately in emergency situations, we strongly recommend that all units be inspected on a monthly basis.

- Check that pressure is adequate and recharge if required.

- Check that seal on handle is intact.
- Check that hose or nozzle is not restricted.

- Keep fire extinguishers clean.

- Note inspection date.

110-120 VOLT IN-STATION LIGHTING

An optional exterior connection allows the use of a 110-120 volt lighting system when coach is being serviced or cleaned.

The receptacle for in-station lighting is located L.H. front side of coach between steering compartment door and front axle. A power cable connected at this point will turn on the interior fluorescent lights. It's circuit breaker, located in steering compartment, beneath driver's floor must be reset manually if tripped.

110-120 VOLT IN-STATION CONNECTORS

The 110-120 volt power connectors can be accessed through the engine oil reserve tank service door (see pages 2-31/32 for location). Connect the female extension cord plug to the vehicle's male connector and the other end of the extension cord to a 110-120 VAC outlet only.

The immersion-type engine block heater's connector is located on the L.H. side and the optional fresh water tank heater's connector is on the R.H. side. Use the heaters whenever the coach is parked for an extended period of time in cold weather and a suitable power source is available.

Both the engine block heater and the water tank heater will automatically be activated when plugged in to an external power source.

CAUTION: Use only a 110-120 VAC power source and only a grounded type (three pronged) extension cord with a minimum rated current capacity of 15 amps. Disconnect the cord before starting engine.

BACK-UP CAMERA

A back-up camera with TV monitor can be installed as an option. When the transmission is placed in (R) reverse range, the camera and TV monitor are automatically switched on. They will switch off when the vehicle is taken out of (R) reverse range.

To clean the camera's protective glass, spray with soapy water and wipe with a clean damp rag or wiper blade.

WARNING: To avoid injury, do not clean camera with transmission in (R) reverse range. Shut-off engine and apply parking brake before cleaning.

CAUTION: To prevent scratches to the camera's protective glass, do not wipe with a dry rag; use a clean damp one.

FILTER RESTRICTION INDICATOR

An optional filter restriction indicator is used to monitor the vacuum level between the air filter and engine. A "red flag" is displayed when the air filter is clogged.

The indicator is located on the engine air intake near the turbocharger. When the "red flag" is displayed, the air filter must be replaced. Press down on indicator to reset flag.

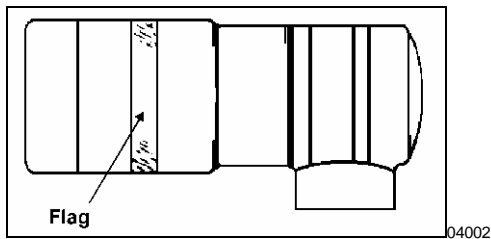

LAVATORY MAINTENANCE

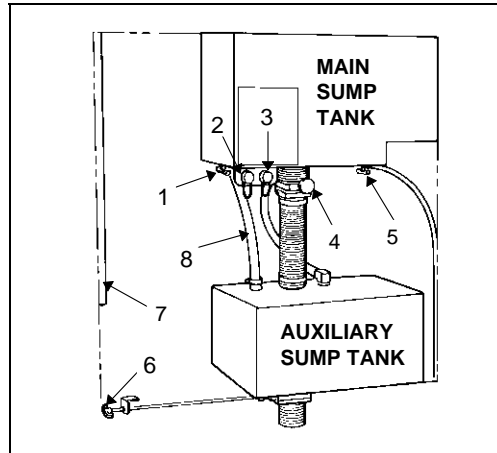

- 1.....Main sump tank overflow cock
- 2..... Fresh water tank fill connection
- 3..... Toilet sump tank fill connection
- 4..... Main sump tank drain valve
- 5..... Fresh water tank drain cock
- 6..... Auxiliary sump tank drain valve
- 7.....Fresh water tank vent and overflow indicator
- 8..... Main sump tank overflow tube

Routine draining and filling of lavatory tanks should be performed by maintenance personnel only. Unless an appropriate power source (110-120 VAC) is available to connect the optional tank heating element (see page 2-31/32 for heater plug location), and if engine or heating failure occurs in extreme weather conditions, emergency draining of water tanks should be performed under the most suitable conditions and should at all times be supervised by driver.

Fresh water reservoir draining

The fresh water reservoir can be drained by simply opening the fresh water drain cock. Don't forget to close cock when draining is done.

CAUTION: If fresh water tank heater is inoperative or not installed on your vehicle, water

should be drained from reservoir under cold weather conditions since it might freeze and damage both reservoir and connecting links.

NOTE: If your vehicle is supplied with a 110-120 volt fresh water tank heater, see "110-120VOLT IN-STATION CONNECTORS" on page 6-10.

Fresh water reservoir filling

Plug the fresh water supply hose to the fresh water tank fill connection; fill the reservoir until the overflow tube leaks, signalling that reservoir is full.

WARNING: Never put antifreeze in fresh water reservoir; antifreeze is toxic.

WARNING: If reservoir has not been drained for an extended period of time, draining and filling operations must be repeated three (3) times in order to clean reservoir and eliminate contaminated water.

Main sump tank draining

To drain sump tank, simply pull main sump tank drain valve until draining is done.

Main sump tank filling

Open the main sump tank overflow cock and connect a water supply hose to the toilet sump tank fill connection. The main tank is full when water starts flowing into the auxiliary tank through the main sump tank overflow tube. Close main sump tank overflow cock.

CAUTION: In cold weather, add 2 gallons (9 liters) of antifreeze (e.g.: ethylene glycol) in the toilet before filling main tank.

Auxiliary sump tank draining

Pull auxiliary sump tank drain valve handle. Close valve when draining is over.

NOTE: It is unlawful to dump sump tank contents in any location other than those designated as such.

Cleaning cabinet

The access door, located at rear of coach on R.H. side can ease cleaning of lavatory. Use this door to introduce electrical cords, vacuum cleaner hoses etc..

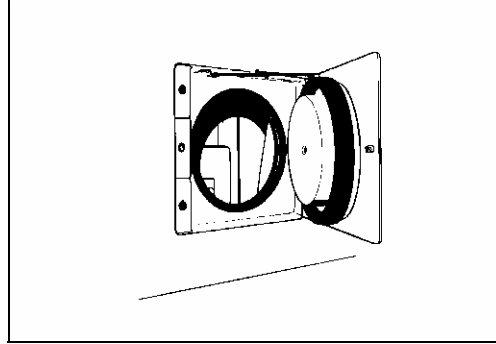

When recirculating water in the toilet is soiled, drain main sump tank into the optional auxiliary tank and perform the filling procedure of the main tank.

When a full draining is required, clean main tank by repeating the draining and filling operations while leaving the auxiliary sump tank drain cock opened. Close cocks and pour a pack of commercial toilet deoderant (Prévost part #900329) in toilet before adding the antifreeze and starting final filling of main tank.

WARNING: The toilet deoderant contains products that can be very irritating to skin. Use rubber gloves when handling and then clean toilet seat.

WARNING: Antifreeze must comply with the effective environmental act.

CAUTION: When cold weather is expected and there is no antifreeze in the tank, both sump tanks must be drained.

NOTE: If there is no antifreeze solution in the tank, there is less risk of freezing if engine is operating due to the heat it produces.

New vehicles do not have an antifreeze solution in the sump tanks at time of delivery.

FIRST SERVICE ON NEW VEHICLE

Differential oil

Factory-filled oil in differential on new vehicle should be drained and refilled between 1,000 miles (1 600 km) and 3,000 miles (4 800 km) of initial operation, then according to the lubrication and servicing schedule.

Coolant strainer

The coolant strainer is designed to recover the soldering residues trapped inside coolant lines during their initial assembly; perform initial cleaning once vehicle has run approximately 3,000 miles (4 800 km), then according to the lubrication and servicing schedule.

NOTE: If additional soldering has been performed on any points of coolant piping, clean coolant system strainer as outlined on new vehicle (3,000 miles (4 800 km)).

On vehicles equipped with driver's A/C system, strainer is located in Reclining Bumper Compartment.



Reclining Bumper Compartment

05022

On vehicles equipped with central A/C system, strainer is located in A/C & Heating Compartment.



A/C & Heating Compartment

05021

Automatic transmission oil filter

Change cartridge after first 3,000 miles (4 800 km), then after each 25,000 miles (40 000 km) as specified in the lubrication and servicing schedule. Check the oil frequently (with engine stopped); if necessary, add sufficient oil to raise level to the proper mark on dipstick.

Manual transmission

We recommend an initial oil change and flush after the transmission is placed in *actual* service. This change should be made any time following 3000 miles (4827 km), but *never exceeding 5000 miles (8045 km)*.

Engine oil

There is no special break-in period since engine break-in has been done in factory; Therefore oil should be changed according to the lubrication and servicing schedule intervals. Check the oil at every fuel filling. If necessary, add sufficient oil to raise the level to the proper mark on dipstick.

LUBRICATION AND SERVICING SCHEDULE

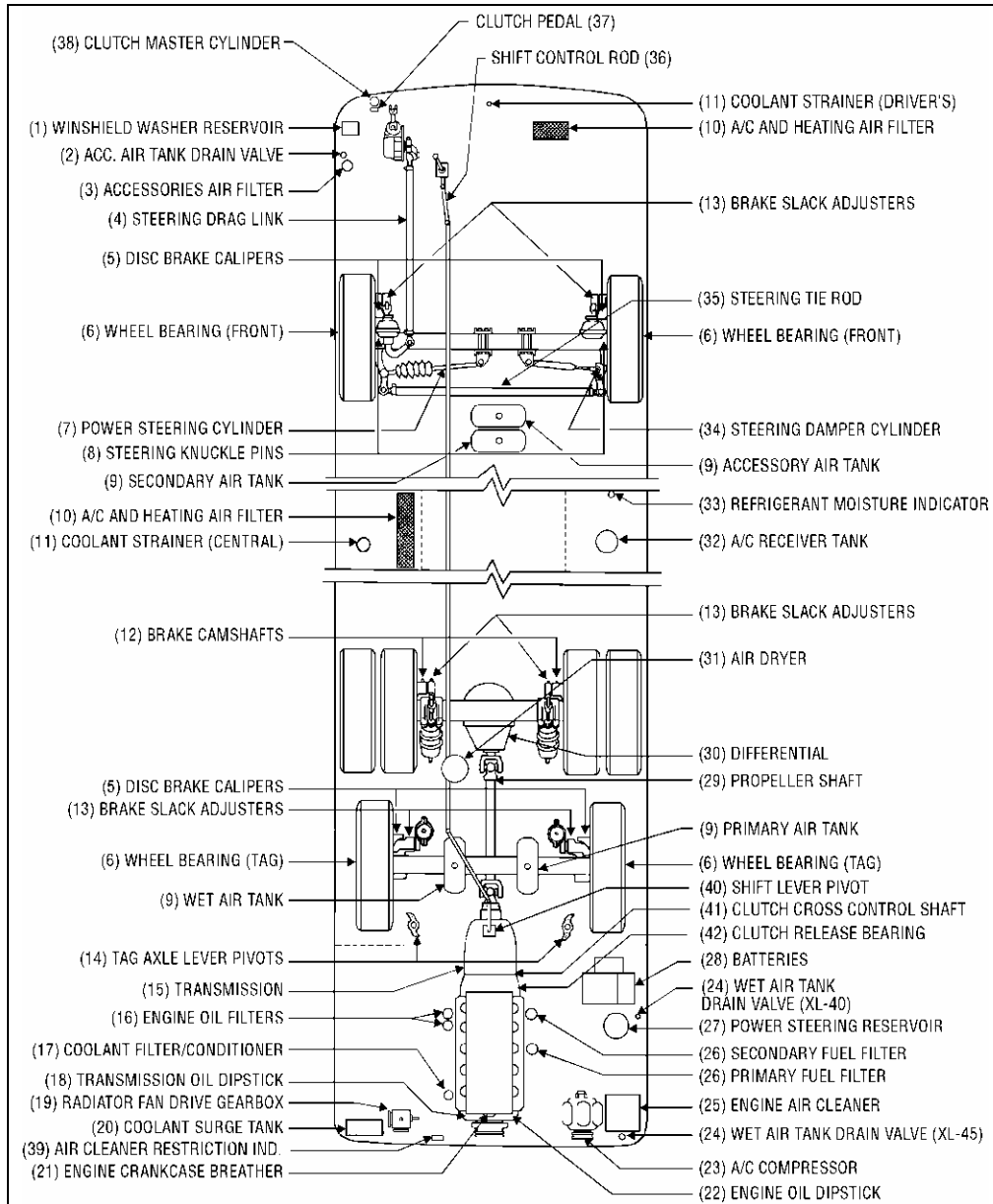

24001

1) BEFORE OPERATING VEHICLE, PERFORM EACH POINT LISTED IN "STARTING AND STOPPING PROCEDURES" SECTION UNDER HEADING "DAILY INSPECTION..." (PAGE 4-9).

NOTE: Perform the "FIRST SERVICE ON NEW VEHICLE" as outlined on page 6-13.

DAILY WALK-AROUND INSPECTION

It is a good practice to make a basic visual inspection of key areas on the vehicle on a daily basis and to report any problem areas to maintenance personnel for immediate correction.

A) Outside the vehicle

| ITEM* | DESCRIPTION |
|--------|--|
| --- | Check for leaks under vehicle and engine compartment |
| --- | Check that baggage and service compartment doors close properly |
| --- | Inspect tires and wheels for correct tire pressure, wear or damage, and for missing wheel stud and nuts |
| 1 | Check windshield washer fluid level and add if necessary |
| --- | Check condition of windshield wiper blades |
| --- | Verify proper operation of all road lights, signal lights, brake lights, marker lights, and back-up lights; Replace light bulbs as required |
| 3 & 24 | Drain accumulated water in accessory and wet air tanks |

B) Engine compartment

| ITEM* | DESCRIPTION |
|---------|---|
| 22 | Check engine crankcase oil level; Add if necessary |
| 18 | Check automatic transmission oil level (level can be checked from pushbutton shift selector); Add if necessary |
| 25 & 39 | Check air cleaner restriction indicator, replace air cleaner when red flag locks in full view |
| 27 | Check power steering reservoir fluid level; Add if necessary |
| 20 | Check coolant surge tank fluid level; Add if necessary |
| 26 | Drain accumulated water in primary fuel filter/water separator (if equipped) |

* Item numbers refer to figure on page 6-14.

C) Inside the vehicle

| ITEM | DESCRIPTION |
|------|--|
| --- | Check for proper operation of the entrance door |
| --- | Inspect cleanliness in the driver's area |
| --- | Check that emergency exit windows and roof escape hatches can be opened, then close all windows and hatches securely |
| --- | Verify proper operation of windshield wiper/washer |
| --- | Check rear view mirrors for broken glass; Adjust mirrors for adequate rear view vision |
| --- | Start engine and check for proper operation of all gauges and indicator lights |
| --- | Check for proper operation of horn(s), and back-up alarm |

PERIODIC LUBRICATION AND SERVICING SCHEDULE

A) Service every 6,250 miles (10 000 km) or twice a year, whichever comes first.

| ITEM* | DESCRIPTION | REMARKS | LUBRICANT &/OR PART** |
|-----------------|--------------------------------|--|--|
| 25 | Engine Air Cleaner | Inspect and clean, replace element if required | Filter: #53-0197 |
| 23 | A/C Compressor | Check oil level, add if necessary | Polyolester oil |
| 32 | A/C Receiver Tank | Check refrigerant level, add if necessary | HFC 134a |
| 33 | Refrigerant Moisture Indicator | Replace filter dryer unit according to moisture indicator | Filter: #45-2542 C/W Moisture indicator |
| 30 | Differential | Check oil level, add if necessary | Multigrade gear oil |
| 15 | Manual transmission | Check oil level | Add if necessary |
| 19 | Radiator Fan Drive Gearbox | Check oil level, add if necessary | Synthetic oil, ISO VG 460 |
| 29 | Propeller shaft | Grease one fitting on each universal joint and one fitting on slip joint | Multi purpose grease |
| 14 | Tag Axle Lever Pivot | Grease one fitting on each pivot | Multi purpose grease |
| 13 | Brake Slack Adjuster | Grease one fitting on each slack adjuster (all axles) | Multi purpose grease |
| 34 | Steering Damper Cylinder | Grease one fitting at cylinder rod end | Multi purpose grease |
| 7 | Power Steering Cylinder | Grease one fitting at each cylinder end | Multi purpose grease |
| 35 | Steering Tie Rod Ends | Grease one fitting at each end | Multi purpose grease |
| 5 | Disc Brake Calipers | Grease two fittings on each of front and tag axles. | Multi purpose grease |
| 4 | Steering Drag Link End | Grease one fitting at each end | Multi purpose grease |
| 40 [▫] | Shift lever pivot | Grease one fitting | Multi purpose grease |
| 41 [▫] | Clutch cross control shaft | Grease three fittings | Multi purpose grease |
| 42 [▫] | Clutch release bearing | Grease one fitting | Multi purpose grease |

* Item numbers refer to figure on page 6-14.

** See end of this section for lubricant and part number specifications.

☐ With manual transmission only.

B) Service every 12,500 miles (20 000 km) or once a year, whichever comes first.

| ITEM* | DESCRIPTION | REMARKS | LUBRICANT &/OR PART** |
|-------|-----------------------------|---|--|
| 16 | Engine | Change oil and filters | Motor oil: SAE 15W40, API CF-4 Filters: #51-0458 |
| 26 | Fuel Filters | Change primary and secondary fuel filters (Fill with clean fuel before installation) | Primary: #51-0137 Prim. w/sep.: #53-1390 Secondary: #51-0128 |
| 17 | Coolant Filter/Conditioner | Replace element | Filter: #55-0630 |
| 38☐ | Clutch master cylinder | Check oil level | Brake fluid (DOT 3) |
| 20 | Coolant surge tank | Test coolant solution | ----- |
| 9 | Air Tanks | Drain accumulated water in all tanks | ----- |
| 10 | A/C and Heating Air Filters | Clean or replace elements - XL-40 prior 2P9M3349XS1001446 - All XL-45 vehicles, and XL-40 From 2P9M3349XS1001446 | Driver's: #87-1049 Central: #37-2545 Driver's: #87-1049 Central: #87-1034 |

C) Service every 25,000 miles (40 000 km) or once a year, whichever comes first.

| ITEM* | DESCRIPTION | REMARKS | LUBRICANT &/OR PART** |
|---------|------------------------------------|-------------------------------|-------------------------|
| 37☐ | Clutch pedal | Check and adjust if necessary | ----- |
| 36☐ | Shift control rod universal joints | Grease four fittings | Multi purpose grease |
| 15 & 18 | Automatic Transmission | Change oil and filters | Dexron-II or Dexron-III |

* Item numbers refer to figure on page 6-14.

** See end of this section for lubricant and part number specifications.

☐ With manual transmission only.

D) Service every 50,000 miles (80 000 km) or once a year, whichever comes first.

CARE & MAINTENANCE

| ITEM* | DESCRIPTION | REMARKS | LUBRICANT &/OR PART** |
|-----------------|-----------------------------|---|---|
| 27 | Power Steering Reservoir | Replace oil filter cartridge element | Cartridge: #66-0987 |
| 6 | Front and Tag Axle Bearings | Refill to level with differential oil or repack with grease | Differential oil or multi purpose grease |
| 11 | Coolant Strainer | Check and clean, change cartridge if required | Driver's: #87-0807 Central: #87-1029 |
| --- | Preheater (WEBASTO) | Test coolant solution | ----- |
| 8 | Steering Knuckle Pins | Grease two fittings on each knuckle | Multi purpose grease |
| 15 [▫] | Manual transmission | Change oil | Engine oil: SAE 30, 40, 50 or gear oil: SAE 80, 90 |
| 19 | Radiator Fan Drive Gearbox | Change oil | Synthetic oil ISO VG 460 |
| 21 | Engine Breather | Clean breather steel mesh | ----- |
| --- | Flexible hoses | Thoroughly inspect all hoses | ----- |

E) Service every 100,000 miles (160 000 km) or once every two years, whichever comes first.

| ITEM* | DESCRIPTION | REMARKS | LUBRICANT &/OR PART** |
|-----------------|------------------------|--|---|
| 3 | Accessories Air Filter | Change filter element | Filter: #64-0080 |
| 31 | Air Dryer | Change cartridge | - Prior V.I.N. 2P9M33493S1001451 Cartridge: #64-1244 - From V.I.N. 2P9M33493S1001451 Cartridge: #64-1278 |
| 38 [▫] | Clutch master cylinder | Drain oil and refill | Brake fluid (DOT 3) |
| 30 | Differential | Change oil, clean breathers | Multigrade gear oil |
| 12 | Brake Camshaft | Grease one fitting on each drive axle drum brake | Multi purpose grease |

* Item numbers refer to figure on page 6-14.

** See end of this section for lubricant and part number specifications.

▫ With manual transmission only.

F) Miscellaneous Service

CARE & MAINTENANCE

| ITEM* | DESCRIPTION | REMARKS | LUBRICANT &/OR PART |
|-------|-------------------|---|--------------------------|
| 28 | Battery Terminals | Clean and coat terminals yearly | Battery terminal coating |
| 20 | Cooling System | Drain, flush and refill every two years or 200,000 miles (320 000 km) | Engine coolant |
| --- | Discharge Tubes** | Every three months: Check 2 condenser's discharge tubes Check 6 evaporator's discharge tubes Check 2 front discharge tubes | ----- |

Lubricant Specifications

| ITEM* | DESCRIPTION | SPECIFICATIONS |
|---------|----------------------------|--|
| 16 | Engine Oil | SAE Viscosity Grade: 15W40 API Classification: CF4 |
| 27 | Power Steering Oil | Automatic Transmission Oil (Dexron-IIe or Dexron-III) |
| 20 | Engine Coolant | Low silicate, ethylene glycol coolant 50% antifreeze/water solution is normally used Antifreeze concentration should be between 30% and 67% |
| 23 | A/C Compressor Oil | Polyolester Oil, HFC 134A compatible Castrol SW-68 (POE) or equivalent |
| 30 | Differential Oil | Gear oil meeting MIL-L-2105-D: 75W90 for Northern climate 80W140 for Southern climate (in extreme conditions or for better performance, full synthetic gear oil can be used.) |
| 19 | Fan Gearbox Oil | Synthetic oil: ISO VG (viscosity grade) 460 Mobil SHC 634 or equivalent |
| 15 & 18 | Automatic Transmission Oil | Dexron-IIe or Dexron-III |
| 15 | Manual transmission oil | Heavy duty engine oil meeting MIL-2104-C: SAE 30 (Northern climate), SAE 40, SAE 50. Straight mineral gear oil: SAE 80 (Northern climate), SAE 90 |
| 38 | Clutch oil | Heavy duty break fluid meeting DOT 3 specifications. |
| --- | Multi Purpose Grease | Good quality lithium-base grease: NLGI No.2 Grade is suitable for most temperatures NLGI No.1 Grade is suitable for extremely low temperatures |

* Item numbers refer to figure on page 6-14.

** Discharge tubes are rubber tubes located under vehicle.

Part Number Specifications

| ITEM* | DESCRIPTION | PREVOST NO | SUPPLIER NO |
|---------|--|---|---|
| 16 | Engine Oil Filters | #51-0458 | Detroit Diesel: 25014505 AC Rochester Div. GM: PF2100 |
| 27 | Power Steering Reservoir Oil Filter | #66-0528 | Garrison Hydraulic: 32516 |
| 25 | Engine Air Cleaner Filter | #53-0197 | Nelson: 70337-N Baldwin: PA-2839 Donaldson: P52-2874 Fram: CA-7113 |
| 33 | Refrigerant Filter Dryer Unit | #45-2542 | Alco controls: EKH 307S (modified) |
| 26 | Engine Primary Fuel Filter | #51-0137 | Detroit Diesel: 25014274 AC Rochester Div. GM: TP-915D |
| 26 | Engine Primary Fuel Filter with Water Separator (optional) | #53-1390 | Detroit Diesel: 25011910 AC Rochester Div. GM: TP-1057 |
| 26 | Engine Secondary Fuel Filter | #51-0128 | Detroit Diesel: 25014342 AC Rochester Div. GM: TP-916D |
| 17 | Engine Coolant Filter/Conditioner | #55-0630 | Detroit Diesel: 23507545 Nalco Chemical Company: DDF3000 |
| 10 | A/C and Heating, Driver's Air Filter | #87-1049 | Permatron Corp.: Model "R" |
| 10 | A/C and Heating, Central Air Filter | XL-40 prior 2P9L33496S1001570 use #870697 XL-40 from 2P9L33496S1001570 use #373336 (top) and #373338 (bottom) all XL-45 's use #373336 (top) and #373337 (bottom) | Airsan Corp.: #AF1-50X Permatron Corp.: IN 1x10x37 EXACT |
| 15 & 18 | Automatic Transmission Oil Filter Kit | #57-1687 | Allison: 29503829 |
| 11 | Coolant Strainer | Driver's: #87-0807 Central: #87-1029 | Braukmann: #13-13-00740 Parker: #925566 |
| 3 | Accessories Air Filter | #64-0080 | Bendix: #222588 |
| 31 | Air Dryer Cartridge | - #64-1243: prior 2P9M33493S1001451 - #64-1278: from 2P9M33493S1001451 | Allied Signal Inc.: #107796 Rockwell Wabco: #S 432 923 2 |

* Item numbers refer to figure on page 6-

TABLE OF CONTENTS

STARTING AND STOPPING

PROCEDURES 4 - 1

| | |
|--|--------|
| General information..... | 4 - 1 |
| Detroit Diesel Electronic Control (DDEC)..... | 4 - 3 |
| World Transmission WT Electronic Control System..... | 4 - 4 |
| Manual transmission..... | 4 - 8 |
| Cold weather starting..... | 4 - 8 |
| Daily inspection..... | 4 - 9 |
| Recommendations..... | 4 - 10 |
| Heating and air conditioning..... | 4 - 11 |
| Preheating systems..... | 4 - 14 |
| Windshield washer reservoir..... | 4 - 15 |
| Jump starting..... | 4 - 16 |
| Electric circuit protection..... | 4 - 17 |
| Tires..... | 4 - 18 |
| Towing..... | 4 - 20 |
| Jacking points..... | 4 - 21 |
| Retractable tag axle..... | 4 - 21 |
| Tag axle unloaded..... | 4 - 21 |

TECHNICAL INFORMATION 5 - 1

| | |
|------------------------|-------|
| Dimensions..... | 5 - 1 |
| Weights..... | 5 - 2 |
| Capacities..... | 5 - 2 |
| Fuel type..... | 5 - 2 |
| Wheels and tires..... | 5 - 2 |
| Belts..... | 5 - 3 |
| Engines..... | 5 - 3 |
| Transmissions..... | 5 - 3 |
| Drive axle ratio..... | 5 - 3 |
| Brakes..... | 5 - 4 |
| Steering..... | 5 - 4 |
| Electrical system..... | 5 - 4 |
| Sound system..... | 5 - 4 |
| Video system..... | 5 - 4 |
| Suspension..... | 5 - 4 |

| | |
|---|--------|
| Alignment..... | 5 - 5 |
| Heating and air conditioning..... | 5 - 5 |
| Oil specifications..... | 5 - 5 |
| Antilock braking system (ABS)..... | 5 - 6 |
| Preheating systems..... | 5 - 6 |
| Storage volume..... | 5 - 6 |
| Seats..... | 5 - 7 |
| DDEC III diagnostic codes..... | 5 - 7 |
| World transmission WT diagnostic codes..... | 5 - 10 |
| Light bulb data..... | 5 - 25 |
| Data plate and certification..... | 5 - 27 |

CARE AND MAINTENANCE 6 - 1

| | |
|---|--------|
| Interior cleaning..... | 6 - 1 |
| Exterior cleaning..... | 6 - 3 |
| Oil verification..... | 6 - 4 |
| Air tanks..... | 6 - 7 |
| Coolant level verification..... | 6 - 8 |
| Water separator..... | 6 - 8 |
| Belt tensioners..... | 6 - 8 |
| A/C and heating air filters..... | 6 - 10 |
| Flexible hose maintenance..... | 6 - 10 |
| Lubrication..... | 6 - 11 |
| Fire extinguishers..... | 6 - 11 |
| 110-120 volt in-station lighting..... | 6 - 11 |
| 110-120 volt in-station connectors..... | 6 - 11 |
| Back-up camera..... | 6 - 12 |
| Filter restriction indicator..... | 6 - 12 |
| Lavatory maintenance..... | 6 - 12 |
| First service on new vehicle..... | 6 - 14 |
| Lubrication and servicing schedule..... | 6 - 15 |

SERVICE LITERATURE 7 - 1

P R E V O S T

***XL Series Motorcoach
SERVICE LITERATURE***

Additional copies of the following Service Literature are available upon request and at low cost.

- Maintenance Manual

- Owner's Manual

- Parts Manual

To order the desired Manual(s), please contact your local distributor or write to:

PRÉVOST CAR INC.

ATTN.: TECHNICAL PUBLICATIONS DEPARTMENT
35 Gagnon Boulevard
Sainte-Claire, Québec
Canada, G0R 2V0
Fax no.: (418) 883 - 4157

Specify your vehicle's complete serial number. Allow 30 days for delivery.

PREVOST**XL Series Motorcoach
INDEX****A**

A/C and heating air filters 6 - 9
 A/C compressor..... 6 - 6
 Accelerator pedal 2 - 25
 Accessories 2 - 38
 Adjustable louver..... 2 - 5, 2 - 17, 2 - 40
 Air filters, A/C & heating 6 - 9
 Air horn 2 - 25, 3 - 5
 Air system emergency fill valves..... 3 - 2
 Air tanks 6 - 7
 Alarm, back up..... 3 - 3
 Alarm system..... 3 - 6
 Alignment..... 5 - 4
 AM/FM stereo cassette 2 - 17
 Antilock braking system 3 - 2, 5 - 6
 Ashtray..... 2 - 17
 Auxiliary sump tank draining 6 - 12

B

Back-up alarm 3 - 3
 Back-up camera / TV monitor 2 - 38, 6 - 11
 Baggage compartment door locks..... 2 - 5
 Battery disconnect switch, main 2 - 2
 Battery equalizers..... 4 - 18
 Belts 5 - 3
 Belt tensioners..... 6 - 8
 Blinds 2 - 40
 Brakes
 ABS 3 - 2, 5 - 6
 Emergency and
 parking brakes 2 - 25, 3 - 1
 Parking brake control..... 2 - 20, 3 - 1
 Parking brake override 2 - 20
 Service brakes 2 - 25, 3 - 1, 5 - 3
 Breakers, main 4 - 17

C

Capacities 5 - 2
 Card tables 2 - 41

 Care and maintenance 6 - 1
 Central A/C and heating controls 2 - 17, 4 - 11
 Changing wheels 4 - 19
 Chime, stop/service power switch 2 - 5, 2 - 41
 Cigarette lighter..... 2 - 17
 Cleaning cabinet 6 - 12
 Cleaning, exterior 6 - 3
 Cleaning, interior 6 - 1
 Clutch pedal 2 - 25
 Coach final record 5 - 28
 Cold starting aid (Ether)..... 4 - 8
 Compartments, exterior
 A/C & heating 2 - 36
 Baggage 2 - 35
 Battery (XL-40) 2 - 37
 Condenser 2 - 36
 Engine..... 2 - 33, 2 - 34
 Engine air intake ducts..... 2 - 33
 Entrance door 2 - 33
 Fuel tank filling door 2 - 33
 L.H. side service (XL-45) 2 - 36
 Main power (XL-45)..... 2 - 36
 Service doors 2 - 36
 Spare wheel and tire 2 - 35
 XL-40 (details) 2 - 31
 XL-45 (details) 2 - 32
 Compartments, interior
 Lavatory 2 - 37
 Parcel racks..... 2 - 38
 Safety equipment compartment..... 2 - 38
 Controls and instrument panels..... 2 - 3
 Coolant level verification..... 6 - 7
 Cruise control switches..... 2 - 5, 2 - 6

D

Dashboard (without tachograph) 2 - 9
 Dashboard (with tachograph) 2 - 10
 Dashboard indicator/warning lights and instruments 2 - 11
 Daily inspection 4 - 9
 Daily walk-around inspection 6 - 15
 Data plate & certification 5 - 27
 Day time running lights 3 - 5
 Defensive driving 3 - 8
 DDEC III diagnostic codes 5 - 7
 Destination sign 2 - 39
 Detroit diesel electronic control (DDEC) 4 - 3
 Diagnostic data reader connector 2 - 6
 Dimensions 5 - 1
 Dome lights 2 - 5
 Door, entrance 2 - 26
 Door override 2 - 20
 DOT certification label 5 - 28
 Drive axle ratio 5 - 3
 Driver's A/C - heating system ctrls 2 - 17, 4 - 12
 Driver's coat hook 2 - 39
 Driver's fan 2 - 39
 Driver's light switch 2 - 5
 Driver's seat 2 - 27
 Driver's window 2 - 38

E

Ether, cold starting aid 4 - 8
 Electrical system 5 - 4
 Electric circuit protection 4 - 17
 Electric horn 2 - 24, 3 - 5
 Emergency warning reflectors 3 - 6
 Engine
 Block heater 4 - 8
 Compartment components 2 - 31, 2 - 32
 Data display and computer - Prodriver[™] 2 - 18
 DDEC 4 - 3
 DDEC III diagnostic codes 5 - 7
 Retarder (jacobs) 2 - 5, 4 - 4
 Starting (from driver's comp.) 4 - 1
 Starting (from engine comp.) 4 - 2
 Warm-up 4 - 8

Engines 5 - 3
 EPA engine labels 5 - 28
 Exits, emergency
 Entrance door 3 - 4
 Roof escape 3 - 4
 Side windows 3 - 4
 Exterior cleaning 6 - 3
 Exterior mirror heating switch 2 - 5
 Extinguishers, fire 3 - 6, 6 - 10

F

Filter restriction indicator 6 - 11
 Fire extinguishers 3 - 6, 6 - 10
 Fire hatchet 3 - 6
 First aid kit 3 - 6
 First service on new vehicle 6 - 13
 Flexible hose maintenance 6 - 9
 Fluorescent lighting 2 - 5
 Fog lights switch 2 - 16, 3 - 5
 Foot-operated controls 2 - 25
 Fresh water reservoir draining 6 - 11
 Fresh water reservoir filling 6 - 12
 Fuel tank filling 2 - 2
 Fuel tank label 5 - 29
 Fuel type 5 - 2
 Fuses 4 - 18

G

Galley 2 - 41
 Galley power switch 2 - 6
 General information 4 - 1

H

Hatchet, fire 3 - 6
 Hazard flashers 2 - 16
 Heating and air conditioning
 Central 2 - 17, 4 - 11
 Driver's 2 - 17, 4 - 12
 Ventilation 4 - 11
 Heating and air conditioning (tech. info) 5 - 5
 Horn, air 2 - 25, 3 - 5
 Horn, electric 2 - 24, 3 - 5
 Hose maintenance, flexible 6 - 9

Hi-buoy / kneeling control switch 2 - 5
 Hi-buoy system..... 3 - 3
 Hubodometer..... 2 - 41

I

Ignition switch 2 - 15
 In-station connectors (110 -120 volt) 6 - 10
 In-station lighting (110 -120 volt)..... 6 - 10
 Interior cleaning..... 6 - 1
 Interphone..... 2 - 39

J

Jacking points..... 4 - 21
 Jack/tools..... 3 - 6
 Jump starting 4 - 16

K

Keys 2 - 1
 Kneeling / hi-buoy control switch 2 - 5
 Kneeling system 3 - 3

L

Lavatory 2 - 37
 Lavatory maintenance..... 6 - 11
 Lever, multifunction 2 - 24
 Lever, transmission retarder 2 - 24
 L.H. lower switch panel 2 - 15
 L.H. outside mirror control..... 2 - 6
 L.H. side control panel..... 2 - 4
 License holder 2 - 39
 Light bulb data 5 - 25
 Lighter, cigarette..... 2 - 17
 Lighting, exterior 2 - 16
 Lighting, fluorescent 2 - 5
 Light switch, driver's 2 - 5
 Lights
 Day time running..... 3 - 5
 Fog 3 - 5
 Louver, adjustable 2 - 5, 2 - 17, 2 - 40
 Low-buoy system 2 - 20, 3 - 3
 Lubricant, part number specs 6 - 21

Lubricant specifications 6 - 20
 Lubrication..... 6 - 10
 Lubrication and servicing schedule 6 - 14

M

Main battery disconnect switch 2 - 2
 Main breakers 4 - 17
 Main power compartment (XL-45)..... 2 - 36
 Main sump tank draining 6 - 12
 Main sump tank filling 6 - 12
 Microphone jacks 2 - 6, 2 - 17, 2 - 39
 Mirrors
 Exterior mirrors 2 - 30
 Heating switch 2 - 5
 Interior mirror 2 - 29
 L.H. outside mirror control..... 2 - 6
 R.H. outside mirror control 2 - 6
 Mud flaps and splash guards 2 - 40
 Multifunction lever 2 - 24

N

New vehicle, first service on 6 - 13

O

Oil specification 5 - 5
 Oil verification
 A/C compressor..... 6 - 6
 Clutch pedal master cylinder 6 - 6
 Engine..... 6 - 4
 Fan gearbox 6 - 6
 Power steering 6 - 6
 Transmission (automatic)..... 6 - 4
 Transmission (manual) 6 - 5
 Wheel bearing 6 - 6
 Override, door 2 - 20

P

PA system volume control 2 - 17
 Panels, control and instrument
 Dashboard 2 - 9, 2 - 10
 L.H. lower switch panel 2 - 15
 L.H. side control panel 2 - 4

R.H. console 2 - 17
 R.H. lower switch panel 2 - 16
 Parcel racks 2 - 38
 Parking brake control 2 - 20, 2 - 25
 Parking brake override 2 - 20
 Part number specifications (lubricants) 6 - 21
 Parts kit, spare 2 - 42
 Passenger seats 2 - 29
 Preheating systems
 Espar 2 - 20, 2 - 43, 4 - 14, 5 - 6
 Webasto 2 - 20, 2 - 44, 4 - 15, 5 - 6
 Prodriver™ - Engine data
 display and computer 2 - 18

Q

"Quick Lounge" system 2 - 41

R

Reading lamps 2 - 5
 Recommendations 4 - 10
 Reflectors, emergency warning 3 - 6
 Retractable tag axle 4 - 21
 R.H. console 2 - 17
 R.H. lateral console 2 - 20
 R.H. lower switch panel 2 - 16
 R.H. outside mirror control 2 - 6

S

Safety attestation 5 - 28
 Safety equipment 3 - 6
 Safety equipment compartment 2 - 38
 Safety precautions 3 - 7
 Seat belts 2 - 28
 Seat, tour guide 2 - 29
 Seats 2 - 27, 5 - 6
 Seats, passenger 2 - 29
 Service literature 7 - 1
 Service, miscellaneous 6 - 20
 Service on new vehicle (first) 6 - 13
 Servicing and lubrication schedule 6 - 14
 Sound system 5 - 4
 Spare parts kit 2 - 42
 Speaker selector switch 2 - 17
 Splash guards and mud flaps 2 - 40

Starting engine from driver's comp't 4 - 1
 Starting engine from engine comp't 4 - 2
 Steering 5 - 4
 Steering wheel and telescopic
 column 2 - 24, 2 - 26
 Stereo receiver, AM/FM 2 - 17
 Stop/service chime power switch 2 - 5, 2 - 41
 Stop/service/reading lamp 2 - 41
 Storage volume 5 - 6
 Suspension 5 - 4

Switches

Auxiliary A/C 2 - 16
 Baggage door lock 2 - 5
 Battery master switch 2 - 15
 Cruise control 2 - 5, 2 - 6
 Dome lights 2 - 5
 Ether cold starting aid 2 - 15
 Exterior lighting switch 2 - 16
 Fast idle 2 - 15
 Fluorescent lighting 2 - 5
 Fog lights 2 - 16
 Galley power 2 - 6
 Hazard flashers 2 - 16
 Ignition 2 - 15
 Kneeling/hi-buoy 2 - 5
 L.H. outside mirror control 2 - 6
 Light, driver's 2 - 5
 Mirror heating 2 - 5
 Reading lamps 2 - 5
 Retarder, engine 2 - 5, 4 - 4
 Retarder, transmission 2 - 5, 4 - 4
 R.H. outside mirror control 2 - 6
 "Stop Engine" override 2 - 15
 Stop/service chime 2 - 5
 Transmission
 pushbutton shifter 2 - 20, 2 - 21
 Video power 2 - 5
 Video volume 2 - 6

T

Tag axle, unloaded or retractable 2 - 20, 4 - 21
 Technical information
 Alignment 5 - 4
 Belts 5 - 3

P R E V O S T

**XL Series Motorcoach
NOTICE**

United States Operators please notice:

Effective with this publication, the National Highway Traffic Safety Administration has requested that the following statement be provided for your information.

If you believe that your vehicle has a defect which could cause a crash or could cause injury or death, you should immediately inform the National Highway Traffic Safety Administration (NHTSA) in addition to notifying Prévost Car Inc..

If NHTSA receives similar complaints, it may open an investigation, and if it finds that a safety defect exists in a group of vehicles, it may order a recall and remedy campaign. However, NHTSA cannot become involved in individual problems between you, your dealer, or Prévost Car Inc..

To contact NHTSA you may either call the Auto Safety Hotline toll-free at 1-800-424-9393 (or 366-0123 in Washington, DC area) or write to: NHTSA, U.S. Department of Transportation, Washington, DC 20590. You can also obtain other information about motor vehicle safety from the Hotline.

P R E V O S T

XL Series Motorcoach
CHANGE OF ADDRESS OR OWNERSHIP

Any change of address or ownership should be brought to the attention of the manufacturer by completing and mailing the attached card.

CHANGE OF ADDRESS

VEHICLE SERIAL NUMBER: 2P9 _ 334 _ _ _ 1001 _ _ _

OLD ADDRESS→

NAME: _____
 STREET NO./APT.: _____
 CITY: _____
 STATE/PROVINCE: _____
 ZIP/POSTAL CODE: _____
 TEL/FAX NO.: _____

NEW ADDRESS→

STREET NO./APT.: _____
 CITY: _____
 STATE/PROVINCE: _____
 ZIP/POSTAL CODE: _____
 TEL/FAX NO.: _____

CUT ON DOTTED LINES

CHANGE OF OWNERSHIP

VEHICLE SERIAL NUMBER: 2P9 _ 334 _ _ _ 1001 _ _ _

The ownership of this vehicle is transferred

FROM→

NAME: _____
 STREET NO./APT.: _____
 CITY: _____
 STATE/PROVINCE: _____
 ZIP/POSTAL CODE: _____
 TEL/FAX NO.: _____

TO→

NAME: _____
 STREET NO./APT.: _____
 CITY: _____
 STATE/PROVINCE: _____
 ZIP/POSTAL CODE: _____
 TEL/FAX NO.: _____

CUT ON DOTTED LINES

affix
stamp
here

P R E V O S T

PRÉVOST CAR INC.
35 Boul. Gagnon
Ste Claire (Québec)
CANADA, G0R 2V0

AFTER-SALES SERVICE DEPARTMENT

affix
stamp
here

P R E V O S T

PRÉVOST CAR INC.
35 Boul. Gagnon
Ste Claire (Québec)
CANADA, G0R 2V0

AFTER-SALES SERVICE DEPARTMENT
