

# WIRING DIAGRAM

## PREVOST

H3-41 & H3-45 BUS

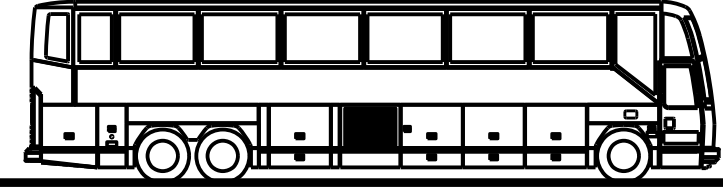
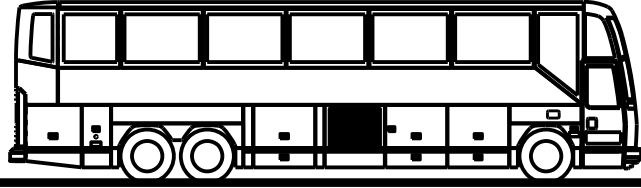

REFERENCE: <span style="font-size: 2em; font-weight: bold;">MODEL 98</span>	NO: <span style="font-size: 2em; font-weight: bold;">D060902</span>
---	---

EFF. W/ OC* <span style="font-size: 1.5em;">97048</span> PRIOR TO / OC*	DR. PATRICE GAGNON	DATE: 97-12-01
EFF. W/ VEH.* <span style="font-size: 1.5em;">W 2234, 2285</span> PRIOR TO / VEH.*	CK. JEAN RUEL <span style="font-size: 1.5em;">R</span>	APPR. ROLAND LAPOINTE <span style="font-size: 1.5em;">R</span>

REV.	DATE	DESCRIPTION	PAGE	BY	CK.	APPR.
01	97-12-08	NEW HOSTESS CHIME EFF.W/W2301 OC#97150 UPDATE: P. A,C,D,G,H,J,1.1.3.1,4.1.5.1,6.1.7.1,7.2.8.1,9.1,9.2,9.3,10.1,11.1,11.2,11.3,11.4,11.5,12.1,13.1,13.2,13.3,14.1,15.1,16.1,17.1,18.1,19.1,20.1,20.3,20.5,21.1,22.1,24.2,25.2,26.1,26.2,28.1.	C, H, 12.1	MW	R	R
02	98-01-08	UPDATE: P. C,7.1,13.1,21.1.		R	MW	R
03	98-02-02	NEW TEMP. SENSOR ON WTEC III EFF.W/W2338 OC#98009	C	MW	R	R
04	98-02-05	NEW WEBASTO TIMER EFF.W/W2372 OC#97154	C, 26.1, 26.2	MW	R	R
05	98-02-17	OPTION CB ADDED UPDATE	A, 2.1, 20.5, J C, 13.3, 23.1	S.G.	R	R
06	98-02-19	NEW ARRANGEMENT THERMISTOR HVAC EFF. W/W2459 OC #97152 ADD LIQUID SOL. VALVE ON HVAC CENTRAL EFF. W/W2459 OC #98001	C,13.1,13.2	R	MW	R
07	98-03-11	NEW LOCK SOL. VALVE ON ENTRANCE DOOR SEDAN EFF. W/W2390 OC #97133 UPDATE	16.1 8.1, 12.1	R	MW	R
08	98-05-05	NEW TRANSMISSION EATON EFF. W/W2589 OC #98031 PAGE: A,E,F,G,H,I,L,1.1,2.1,3.1,4.1, PAGE: 5.1,6.1,6.3,7.1,7.2,15.1 UPDATE PAGE: B1,B1sp1,B1sp2,K,4.1sp1,4.1sp2,5.1sp1,5.1sp2,8.1,9.1,9.2,9.3,11.2,11.3,13.1,14.1, 15.1sp1,18.1,18.1sp1,18.1sp3,19.1,20.1,22.1,21.1sp1,24.1,24.2,24.3,25.1,25.2,27.1,28.1	S.G.	R	R	R
09	98-07-02	NEW WIRING HARNESS FOR CLEARANCE LIGHT OC #98028 EFF. W/ X-2638 RELAY R8 AND R11 REMOVED . OC # 98048 EFF. W/X-2657	C C,F,I,2.1,4.1,4.1SP1, 4.1SP2,4.1SP3,5.1, 5.1SP1, 5.1SP2, 6.1 6.3, 8.1,19.1,4.1SP4 13.3	R	R	R
10	98-07-02	NEW WIRING HARNESS FOR A/C IN PARCEL RACK OC #98073 EFF. W/ X-2670 NEW WIRING HARNESS FOR 2 SPDS IN HAT RACK BLOWER OC #98069 EFF. W/ X-2726	C, I, 11.3, 13.3	P.G.	R	R
11	98-07-14	HUMIDISTAT REMOVED O.C. #98090 EFF. W/ X-2814	C,13.2	R	R	R

## PREVOST H3-41 & H3-45 BUS

NO: D060902 P. 2/2

REV.	DATE	DESCRIPTION	PAGE	BY	CK.	APPR.
12	98-09-17	NEW OPTION FRONT CAMERA O.C.#98117 EFF. W/X2639 UPDATE PAGE: J,1.1,1.2,2.1,3.1,8.1,13.2SP1,13.2SP2,13.3,20.1,21.1,21.1SP1,23.1	A, G, 20.7	S.G.	R	R
13	98-09	LIQ. SOL. VALVE ADDED ON PASSENGER A/C SYSTEM WB 98-33 EFF. W2285 TO W2457	P. 13.2	J.R.	R	R
14	98-10	RESISTOR ADDED IN SERIAL WITH COIL OF CONDENSER RELAY OC#98112 EFF. X2811	P. J,13.1	J.R.	R	R
15	98-10	CABLE 12VF AND BREAKER CB4 WERE INCREASE OC # 98133 EFF.: X-2871	P. B1,B1SP1,B1SP2,F 1.1,2.1	J.R.	R	R
16	98-11	INTRODUCTION TWO ALTERNAROR BOSCH OC#98012 EFF. X-2831, X-2901...	P. A,B1,C,E,F,G,H,I,J, 1.1,2.1,4.1,4.2,6.1 7.1,8.1,9.1,13.1,13.3, 22.1,23.1,25.1,25.2	J.R.	R	R
17	98-11	UPDATE PAGE: D, 2.1, 5.1SP1, 5.1SP2, 20.3, 20.7, 23.1		S.G.	R	R
17	98-11	ABS DIFFERENTIEL SENSOR EFF. W/X2886 OC#98075	C, G	S.G.	R	R
17	98-11	NEW DRIVER SPEAKER EFF.W/X2946 OC#98161	20.1	S.G.	R	R
18	98-12	UPDATE	4.1 sp4	S.G.	R	R
19	99-01	UPDATE BOSCH ALTERNATOR CIRCUIT	P. 1.1, 4.1, 4.2	J.R.	R	R
20	99-01	ENGINE DOOR SW. REPLACED O.C. # 98135 EFF. / X3022	P. C, 11.1	J.R.	R	R
21	99-01	INTRODUCTION ELECTRONIC CONTROL FOR BOSCH ALTERNATOR EFF. / X3033	P. 4.2, M	J.R.	R	R
22	99-01	UPDTATE	9.2sp2, 11.3sp2	S.G.	R	R
23	99-04	RESISTOR ADDED ON OPEN ENT. DOOR SOLENOID O.C.#99050 EFF. X-3190	P. J,16.1	J.R.	R	R
24	99-04	INTRODUCTION NEW CHARGER VANNER 41 AMP. OC# 99008 EFF./ X3213	P. B1,B1sp1,B1sp2, B2,C,2.1,4.2,5.1, 8.1,11.4	J.R.	R	R

## WIRING DIAGRAM INDEX

<b>A</b> A/C, HEAT & VENT. SYSTEM      Page: 13.1 AIR DRYER      Page: 8.1 ALARM & SIGNAL      Page: 7.2 ABS      Page: 21.1 ARRANGEMENT - CABLE      Page: B ARRANGEMENT - HARNESS      Page: C ARRANGEMENT - SPARE WIRE      Page: D	DRIVER'S WINDOW LIFTER      Page: 14.1  <b>E</b> ENGINE BLOCK HEATER      Page: 12.1 ENGINE BRAKE SYSTEM      Page: 19.1 ENGINE CONTROL      Page: 4.1 ENTRANCE DOOR SEDAN      Page: 16.1 ETHER COLD START      Page: 8.1 EXTERIOR LIGHTING      Page: 9.1	<b>M</b> MIRROR-REAR VIEW      Page: 24.1 <b>P</b> PARKING BRAKE SWITCH      Page: 8.1 POWER 12V OUTLET      Page: 14.1 PRODRIVER      Page: 8.1  <b>R</b> RETARDER - WORLD TRANSM.      Page: 19.1  <b>S</b> SOUND & VIDEO SYSTEM      Page: 20.1 SUN VISOR      Page: 14.1  <b>T</b> TELL TALE LIGHT MODULES      Page: 28.1 TRANSMISSION - MANUAL      Page: 22.1 TRANSMISSION - WORLD      Page: 6.1
<b>B</b> BACK-UP ALARM      Page: 9.3 BACK-UP MONITOR      Page: 27.1 BATTERY STANDARD AND 8D      Page: 1.2	<b>F</b> FAN-CLUTCH RADIATOR      Page: 8.1 FAST IDLE - DDEC      Page: 5.1 FIRE DETECTOR      Page: 7.2 FRONT DESTINATION SIGN      Page: 17.1 FUEL WATER FILTER      Page: 8.1 FUEL PRIME PUMP      Page: 12.1	<b>W</b> WATER HEATER PRE-HEAT      Page: 26.1 WATER TANK HEATER LAVATORY      Page: 12.1 WHEEL CHAIR LIFT - RICHON 9000      Page: 25.2 WHEEL CHAIR LIFT - STEW. & STEV.      Page: 25.1 WINDOW AJAR      Page: 7.2 WINDSHIELD (UP) FAN DEFROSTOR      Page: 22.1 WINDSHIELD (UP) HEATED      Page: 22.1 WIPER & WASHER      Page: 10.1
<b>C</b> CLUSTER      Page: 7.1 CHARGING SYSTEM      Page: 4.1 CIGAR LIGHTER      Page: 14.1 CODE - CIRCUIT NUMBER      Page: E CODE - CIRCUIT BREAKER      Page: F CODE - CONNECTOR      Page: G CODE - DIODE      Page: H CODE - RELAY      Page: I CODE - RESISTOR      Page: J CODE - WIRING KEY      Page: K CODE - FUSE      Page: L CODE - MODULE      Page: M CRUISE CONTROL - DDEC      Page: 5.1	<b>G</b> GALLEY ACCESSORIES      Page: 23.1 GROUND SYSTEM      Page: 3.1  <b>H</b> HIGH BUOY      Page: 18.1 HOTESS CHIME      Page: 12.1  <b>I</b> INTERIOR LIGHTING      Page: 11.1 INTERCOM      Page: 27.1  <b>K</b> KNEELING SYSTEM      Page: 18.1	
<b>D</b> DDEC III      Page: 5.1 DIGITAL CLOCK      Page: 14.1 DISTRIBUTION 12V, 24V      Page: 1.1 DISTRIB. 12V DISC., IGN & HOT WIRE      Page: 2.1	<b>L</b> LAVATORY      Page: 17.1 LOW BUOY      Page: 18.1 LUGGAGE DOOR LOCK      Page: 19.1	

## WIRING DIAGRAM INDEX

<b>A</b> A/C, HEAT & VENT. SYSTEM      Page: 13.1 AIR DRYER      Page: 8.1 ALARM & SIGNAL      Page: 7.2 ABS      Page: 21.1 ARRANGEMENT - CABLE      Page: B ARRANGEMENT - HARNESS      Page: C ARRANGEMENT - SPARE WIRE      Page: D	DISTRIB. 12V DISC., IGN & HOT WIRE      Page: 2.1 DRIVER'S WINDOW LIFTER      Page: 14.1  <b>E</b> ENGINE BLOCK HEATER      Page: 12.1 ENGINE BRAKE SYSTEM      Page: 19.1 ENGINE CONTROL      Page: 4.1 ENTRANCE DOOR SEDAN      Page: 16.1 ETHER COLD START      Page: 8.1 EXTERIOR LIGHTING      Page: 9.1  <b>F</b> FAN-CLUTCH RADIATOR      Page: 8.1 FAST IDLE - DDEC      Page: 5.1 FIRE DETECTOR      Page: 7.2 FRONT DESTINATION SIGN      Page: 17.1 FUEL WATER FILTER      Page: 8.1 FUEL PRIME PUMP      Page: 12.1  <b>G</b> GALLEY ACCESSORIES      Page: 23.1 GROUND SYSTEM      Page: 3.1  <b>H</b> HIGH BUOY      Page: 18.1 HOTESS CHIME      Page: 12.1  <b>I</b> INTERIOR LIGHTING      Page: 11.1 INTERCOM      Page: 27.1  <b>K</b> KNEELING SYSTEM      Page: 18.1  <b>L</b> LAVATORY      Page: 17.1 LOW BUOY      Page: 18.1	LUGGAGE DOOR LOCK      Page: 19.1  <b>M</b> MIRROR-REAR VIEW      Page: 24.1 <b>P</b> PARKING BRAKE SWITCH      Page: 8.1 POWER 12V OUTLET      Page: 14.1 PRODRIVER      Page: 8.1  <b>R</b> RETARDER - WORLD TRANSM.      Page: 19.1  <b>S</b> SPEED SWITCH (MANUAL TRANS.)      15.1 SOUND & VIDEO SYSTEM      Page: 20.1 SPEAKER PASSENGER      Page: 20.2 SUN VISOR      Page: 14.1  <b>T</b> TELL TALE LIGHT MODULES      Page: 28.1 TRANSMISSION - MANUAL      Page: 15.1 TRANSMISSION - WORLD      Page: 6.1  <b>W</b> WATER HEATER PRE-HEAT      Page: 26.1 WATER TANK HEATER LAVATORY      Page: 12.1 WHEEL CHAIR LIFT - RICHON 9000      Page: 25.2 WHEEL CHAIR LIFT - STEW. & STEV.      Page: 25.1 WINDOW AJAR      Page: 7.2 WINDSHIELD (UP) FAN DEFROSTOR      Page: 22.1 WINDSHIELD (UP) HEATED      Page: 22.1 WIPER & WASHER      Page: 10.1
<b>B</b> BACK-UP ALARM      Page: 9.3 BACK-UP MONITOR      Page: 27.1 BATTERY CHARGER      Page: 11.4 BATTERY STANDARD AND 8D      Page: 1.2		
<b>C</b> CLUSTER      Page: 7.1 CHARGING SYSTEM      Page: 4.1 CIGAR LIGHTER      Page: 14.1 CODE - CIRCUIT NUMBER      Page: E CODE - CIRCUIT BREAKER      Page: F CODE - CONNECTOR      Page: G CODE - DIODE      Page: H CODE - RELAY      Page: I CODE - RESISTOR      Page: J CODE - WIRING KEY      Page: K CODE - FUSE      Page: L CODE - MODULE      Page: M CRUISE CONTROL - DDEC      Page: 5.1		
<b>D</b> DDEC III & IV      Page: 5.1 DIGITAL CLOCK      Page: 14.1 DISTRIBUTION 12V, 24V      Page: 1.1		

## WIRING DIAGRAM INDEX

<b>A</b> A/C, HEAT & VENT. SYSTEM AIR DRYER ALARM & SIGNAL ABS ARRANGEMENT - CABLE ARRANGEMENT - HARNESS ARRANGEMENT - SPARE WIRE	Page: 13.1 Page: 8.1 Page: 7.2 Page: 21.1 Page: B Page: C Page: D	DISTRIBUTION 12V, 24V DISTRIB. 12V DISC., IGN & HOT WIRE DRIVER'S WINDOW LIFTER	Page: 1.1 Page: 2.1 Page: 14.1	LOW BUOY LUGGAGE DOOR LOCK	Page: 18.1 Page: 19.1
<b>B</b> BACK-UP ALARM BACK-UP MONITOR BATTERY CHARGER BATTERY STANDARD AND 8D	Page: 9.3 Page: 27.1 Page: 11.4 Page: 1.2	<b>E</b> ENGINE BLOCK HEATER ENGINE BRAKE SYSTEM ENGINE CONTROL ENTRANCE DOOR SEDAN ETHER COLD START EXTERIOR LIGHTING	Page: 12.1 Page: 19.1 Page: 4.1 Page: 16.1 Page: 8.1 Page: 9.1	<b>M</b> MIRROR-REAR VIEW <b>P</b> PARKING BRAKE SWITCH POWER 12V OUTLET PRODRIVER	Page: 24.1 Page: 8.1 Page: 14.1 Page: 8.1
<b>C</b> CLUSTER CHARGING SYSTEM CIGAR LIGHTER CODE - CIRCUIT NUMBER CODE - CIRCUIT BREAKER CODE - CONNECTOR CODE - DIODE CODE - RELAY CODE - RESISTOR CODE - WIRING KEY CODE - FUSE CODE - MODULE CRUISE CONTROL - DDEC CB OPTION	Page: 7.1 Page: 4.1 Page: 14.1 Page: E Page: F Page: G Page: H Page: I Page: J Page: K Page: L Page: M Page: 5.1 Page: 20.5	<b>F</b> FAN-CLUTCH RADIATOR FAST IDLE - DDEC FIRE DETECTOR FRONT DESTINATION SIGN FUEL WATER FILTER FUEL PRIME PUMP	Page: 8.1 Page: 5.1 Page: 7.2 Page: 17.1 Page: 8.1 Page: 12.1	<b>S</b> SPEED SWITCH (MANUAL TRANS.) SOUND & VIDEO SYSTEM SPEAKER PASSENGER SUN VISOR	15.1 Page: 20.1 Page: 20.2 Page: 14.1
<b>D</b> DDEC III & IV DIGITAL CLOCK	Page: 5.1 Page: 14.1	<b>G</b> GALLEY ACCESSORIES GROUND SYSTEM	Page: 23.1 Page: 3.1	<b>T</b> TELL TALE LIGHT MODULES TRANSMISSION - MANUAL TRANSMISSION - WORLD	Page 28.1 Page: 15.1 Page: 6.1
		<b>H</b> HIGH BUOY HOTESS CHIME	Page: 18.1 Page: 12.1	<b>W</b> WATER HEATER PRE-HEAT WATER TANK HEATER LAVATORY WHEEL CHAIR LIFT - RICHON 9000 WHEEL CHAIR LIFT - STEW. & STEV. WINDOW AJAR WINDSHIELD (UP) FAN DEFROSTOR WINDSHIELD (UP) HEATED WIPER & WASHER	Page: 26.1 Page: 12.1 Page: 25.2 Page: 25.1 Page: 7.2 Page: 22.1 Page: 22.1 Page: 10.1
		<b>I</b> INTERIOR LIGHTING INTERCOM	Page: 11.1 Page: 27.1		
		<b>K</b> KNEELING SYSTEM	Page: 18.1		
		<b>L</b> LAVATORY	Page: 17.1		



## WIRING DIAGRAM INDEX

<b>A</b> A/C, HEAT & VENT. SYSTEM      Page: 13.1 AIR DRYER      Page: 8.1 ALARM & SIGNAL      Page: 7.2 ABS      Page: 21.1 ARRANGEMENT - CABLE      Page: B ARRANGEMENT - HARNESS      Page: C ARRANGEMENT - SPARE WIRE      Page: D	DISTRIBUTION 12V, 24V      Page: 1.1 DISTRIB. 12V DISC., IGN & HOT WIRE      Page: 2.1 DRIVER'S WINDOW LIFTER      Page: 14.1  <b>E</b> ENGINE BLOCK HEATER      Page: 12.1 ENGINE BRAKE SYSTEM      Page: 19.1 ENGINE CONTROL      Page: 4.1 ENTRANCE DOOR SEDAN      Page: 16.1 ETHER COLD START      Page: 8.1 EXTERIOR LIGHTING      Page: 9.1  <b>F</b> FAN-CLUTCH RADIATOR      Page: 8.1 FAST IDLE - DDEC      Page: 5.1 FIRE DETECTOR      Page: 7.2 FRONT DESTINATION SIGN      Page: 17.1 FUEL WATER FILTER      Page: 8.1 FUEL PRIME PUMP      Page: 12.1  <b>G</b> GALLEY ACCESSORIES      Page: 23.1 GROUND SYSTEM      Page: 3.1  <b>H</b> HIGH BUOY      Page: 18.1 HOTESS CHIME      Page: 12.1  <b>I</b> INTERIOR LIGHTING      Page: 11.1 INTERCOM      Page: 27.1  <b>K</b> KNEELING SYSTEM      Page: 18.1  <b>L</b> LAVATORY      Page: 17.1 LOW BUOY      Page: 18.1	LUGGAGE DOOR LOCK      Page: 19.1  <b>M</b> MIRROR-REAR VIEW      Page: 24.1  <b>P</b> PARKING BRAKE SWITCH      Page: 8.1 POWER 12V OUTLET      Page: 14.1 PRODRIVER      Page: 8.1  <b>R</b> RETARDER - WORLD TRANSM.      Page: 19.1  <b>S</b> SPEED SWITCH (MANUAL TRANS.)      15.1 SOUND & VIDEO SYSTEM      Page: 20.1 SPEAKER PASSENGER      Page: 20.2 SUN VISOR      Page: 14.1  <b>T</b> TELL TALE LIGHT MODULES      Page 28.1 TRANSMISSION - MANUAL      Page: 15.1 TRANSMISSION - WORLD      Page: 6.1 TRANSMISSION - EATON      Page: 6.3  <b>W</b> WATER HEATER PRE-HEAT      Page: 26.1 WATER TANK HEATER LAVATORY      Page: 12.1 WHEEL CHAIR LIFT - RICON 9000      Page: 25.2 WHEEL CHAIR LIFT - STEW. & STEV.      Page: 25.1 WINDOW AJAR      Page: 7.2 WINDSHIELD (UP) FAN DEFROSTOR      Page: 22.1 WINDSHIELD (UP) HEATED      Page: 22.1 WIPER & WASHER      Page: 10.1
<b>B</b> BACK-UP ALARM      Page: 9.3 BACK-UP MONITOR      Page: 27.1 BATTERY CHARGER      Page: 11.4 BATTERY STANDARD AND 8D      Page: 1.2		
<b>C</b> CLUSTER      Page: 7.1 CHARGING SYSTEM      Page: 4.1 CIGAR LIGHTER      Page: 14.1 CODE - CIRCUIT NUMBER      Page: E CODE - CIRCUIT BREAKER      Page: F CODE - CONNECTOR      Page: G CODE - DIODE      Page: H CODE - RELAY      Page: I CODE - RESISTOR      Page: J CODE - WIRING KEY      Page: K CODE - FUSE      Page: L CODE - MODULE      Page: M CRUISE CONTROL - DDEC      Page: 5.1 CB OPTION      Page: 20.5		
<b>D</b> DDEC III & IV      Page: 5.1 DIGITAL CLOCK      Page: 14.1		

## WIRING DIAGRAM INDEX

<b>A</b> A/C, HEAT & VENT. SYSTEM      Page: 13.1 AIR DRYER      Page: 8.1 ALARM & SIGNAL      Page: 7.2 ABS      Page: 21.1 ARRANGEMENT - CABLE      Page: B ARRANGEMENT - HARNESS      Page: C ARRANGEMENT - SPARE WIRE      Page: D	DISTRIBUTION 12V, 24V      Page: 1.1 DISTRIB. 12V DISC., IGN & HOT WIRE      Page: 2.1 DRIVER'S WINDOW LIFTER      Page: 14.1  <b>E</b> ENGINE BLOCK HEATER      Page: 12.1 ENGINE BRAKE SYSTEM      Page: 19.1 ENGINE CONTROL      Page: 4.1 ENTRANCE DOOR SEDAN      Page: 16.1 ETHER COLD START      Page: 8.1 EXTERIOR LIGHTING      Page: 9.1  <b>F</b> FAN-CLUTCH RADIATOR      Page: 8.1 FAST IDLE - DDEC      Page: 5.1 FIRE DETECTOR      Page: 7.2 FRONT DESTINATION SIGN      Page: 17.1 FRONT CAMERA      Page: 20.7 FUEL WATER FILTER      Page: 8.1 FUEL PRIME PUMP      Page: 12.1  <b>G</b> GALLEY ACCESSORIES      Page: 23.1 GROUND SYSTEM      Page: 3.1  <b>H</b> HIGH BUOY      Page: 18.1 HOTESS CHIME      Page: 12.1  <b>I</b> INTERIOR LIGHTING      Page: 11.1 INTERCOM      Page: 27.1  <b>K</b> KNEELING SYSTEM      Page: 18.1  <b>L</b> LAVATORY      Page: 17.1 LOW BUOY      Page: 18.1	LUGGAGE DOOR LOCK      Page: 19.1  <b>M</b> MIRROR-REAR VIEW      Page: 24.1  <b>P</b> PARKING BRAKE SWITCH      Page: 8.1 POWER 12V OUTLET      Page: 14.1 PRODRIVER      Page: 8.1  <b>R</b> RETARDER - WORLD TRANSM.      Page: 19.1  <b>S</b> SPEED SWITCH (MANUAL TRANS.)      15.1 SOUND & VIDEO SYSTEM      Page: 20.1 SPEAKER PASSENGER      Page: 20.2 SUN VISOR      Page: 14.1  <b>T</b> TELL TALE LIGHT MODULES      Page: 28.1 TRANSMISSION - MANUAL      Page: 15.1 TRANSMISSION - WORLD      Page: 6.1 TRANSMISSION - EATON      Page: 6.3  <b>W</b> WATER HEATER PRE-HEAT      Page: 26.1 WATER TANK HEATER LAVATORY      Page: 12.1 WHEEL CHAIR LIFT - RICON 9000      Page: 25.2 WHEEL CHAIR LIFT - STEW. & STEV.      Page: 25.1 WINDOW AJAR      Page: 7.2 WINDSHIELD (UP) FAN DEFROSTOR      Page: 22.1 WINDSHIELD (UP) HEATED      Page: 22.1 WIPER & WASHER      Page: 10.1
<b>B</b> BACK-UP ALARM      Page: 9.3 BACK-UP MONITOR      Page: 27.1 BATTERY CHARGER      Page: 11.4 BATTERY STANDARD AND 8D      Page: 1.2		
<b>C</b> CLUSTER      Page: 7.1 CHARGING SYSTEM      Page: 4.1 CIGAR LIGHTER      Page: 14.1 CODE - CIRCUIT NUMBER      Page: E CODE - CIRCUIT BREAKER      Page: F CODE - CONNECTOR      Page: G CODE - DIODE      Page: H CODE - RELAY      Page: I CODE - RESISTOR      Page: J CODE - WIRING KEY      Page: K CODE - FUSE      Page: L CODE - MODULE      Page: M CRUISE CONTROL - DDEC      Page: 5.1 CB OPTION      Page: 20.5		
<b>D</b> DDEC III & IV      Page: 5.1 DIGITAL CLOCK      Page: 14.1		

## WIRING DIAGRAM INDEX

<b>A</b> A/C, HEAT & VENT. SYSTEM      Page: 13.1 AIR DRYER      Page: 8.1 ALARM & SIGNAL      Page: 7.2 ABS      Page: 21.1 ARRANGEMENT - CABLE      Page: B ARRANGEMENT - HARNESS      Page: C ARRANGEMENT - SPARE WIRE      Page: D	DISTRIBUTION 12V, 24V      Page: 1.1 DISTRIB. 12V DISC., IGN & HOT WIRE      Page: 2.1 DRIVER'S WINDOW LIFTER      Page: 14.1  <b>E</b> ENGINE BLOCK HEATER      Page: 12.1 ENGINE BRAKE SYSTEM      Page: 19.1 ENGINE CONTROL      Page: 4.1 ENTRANCE DOOR SEDAN      Page: 16.1 ETHER COLD START      Page: 8.1 EXTERIOR LIGHTING      Page: 9.1  <b>F</b> FAN-CLUTCH RADIATOR      Page: 8.1 FAST IDLE - DDEC      Page: 5.1 FIRE DETECTOR      Page: 7.2 FRONT DESTINATION SIGN      Page: 17.1 FRONT CAMERA      Page: 20.7 FUEL WATER FILTER      Page: 8.1 FUEL PRIME PUMP      Page: 12.1  <b>G</b> GALLEY ACCESSORIES      Page: 23.1 GROUND SYSTEM      Page: 3.1  <b>H</b> HIGH BUOY      Page: 18.1 HOTESS CHIME      Page: 12.1  <b>I</b> INTERIOR LIGHTING      Page: 11.1 INTERCOM      Page: 27.1  <b>K</b> KNEELING SYSTEM      Page: 18.1  <b>L</b> LAVATORY      Page: 17.1 LOW BUOY      Page: 18.1	LUGGAGE DOOR LOCK      Page: 19.1  <b>M</b> MIRROR-REAR VIEW      Page: 24.1  <b>P</b> PARKING BRAKE SWITCH      Page: 8.1 POWER 12V OUTLET      Page: 14.1 PRODRIVER      Page: 8.1  <b>R</b> RETARDER - WORLD TRANSM.      Page: 19.1  <b>S</b> SPEED SWITCH (MANUAL TRANS.)      15.1 SOUND & VIDEO SYSTEM      Page: 20.1 SPEAKER PASSENGER      Page: 20.2 SUN VISOR      Page: 14.1  <b>T</b> TELL TALE LIGHT MODULES      Page 28.1 TRANSMISSION - MANUAL      Page: 15.1 TRANSMISSION - WORLD      Page: 6.1 TRANSMISSION - EATON      Page: 6.3  <b>W</b> WATER HEATER PRE-HEAT      Page: 26.1 WATER TANK HEATER LAVATORY      Page: 12.1 WHEEL CHAIR LIFT - RICON 9000      Page: 25.2 WHEEL CHAIR LIFT - STEW. & STEV.      Page: 25.1 WINDOW AJAR      Page: 7.2 WINDSHIELD (UP) FAN DEFROSTOR      Page: 22.1 WINDSHIELD (UP) HEATED      Page: 22.1 WIPER & WASHER      Page: 10.1
<b>B</b> BACK-UP ALARM      Page: 9.3 BACK-UP MONITOR      Page: 27.1 BATTERY CHARGER      Page: 11.4 BATTERY STANDARD AND 8D      Page: 1.2		
<b>C</b> CLUSTER      Page: 7.1 CHARGING SYSTEM      Page: 4.2 CIGAR LIGHTER      Page: 14.1 CODE - CIRCUIT NUMBER      Page: E CODE - CIRCUIT BREAKER      Page: F CODE - CONNECTOR      Page: G CODE - DIODE      Page: H CODE - RELAY      Page: I CODE - RESISTOR      Page: J CODE - WIRING KEY      Page: K CODE - FUSE      Page: L CODE - MODULE      Page: M CRUISE CONTROL - DDEC      Page: 5.1 CB OPTION      Page: 20.5		
<b>D</b> DDEC III & IV      Page: 5.1 DIGITAL CLOCK      Page: 14.1		

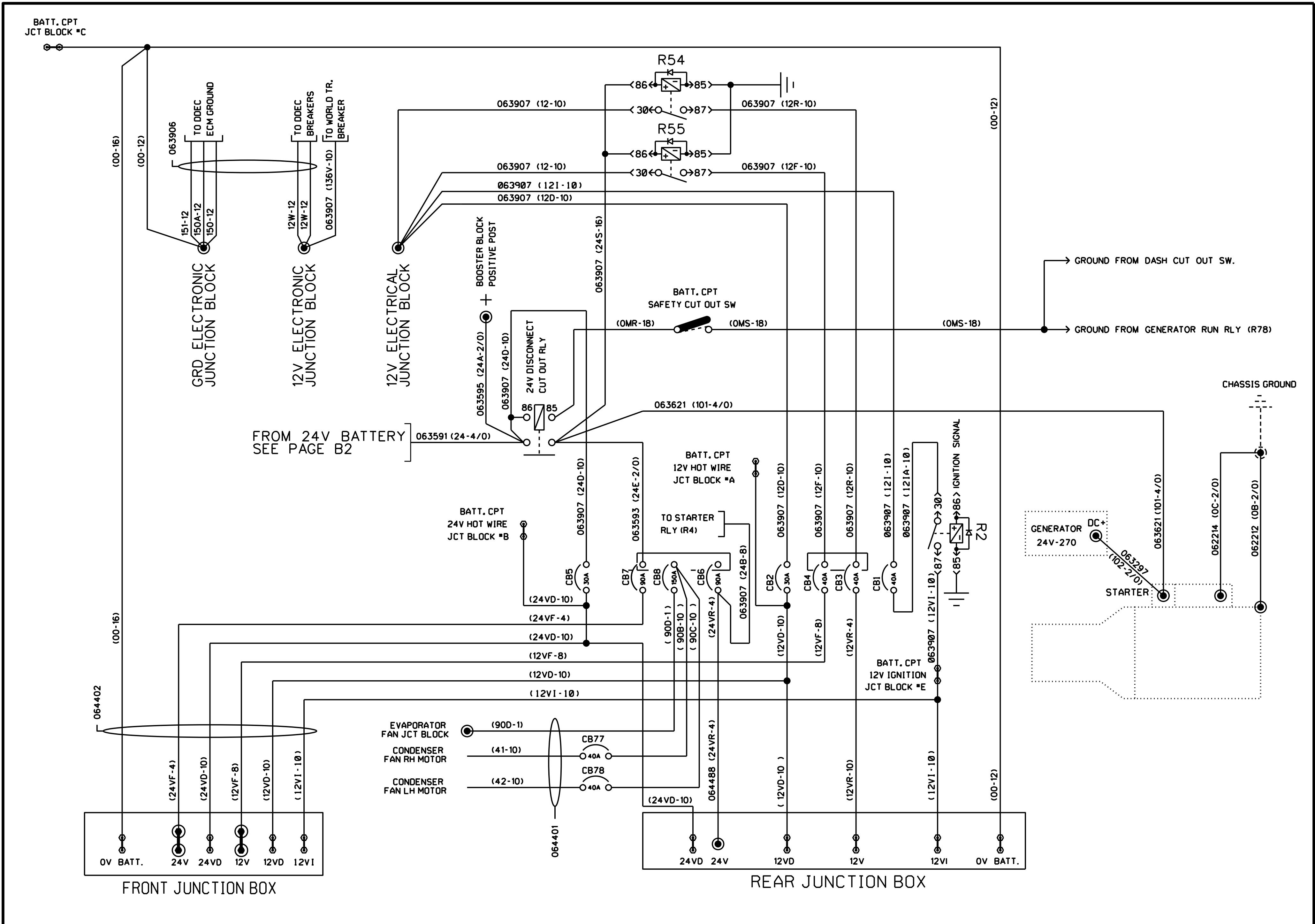

BATT. CPT  
JCT BLOCK #C

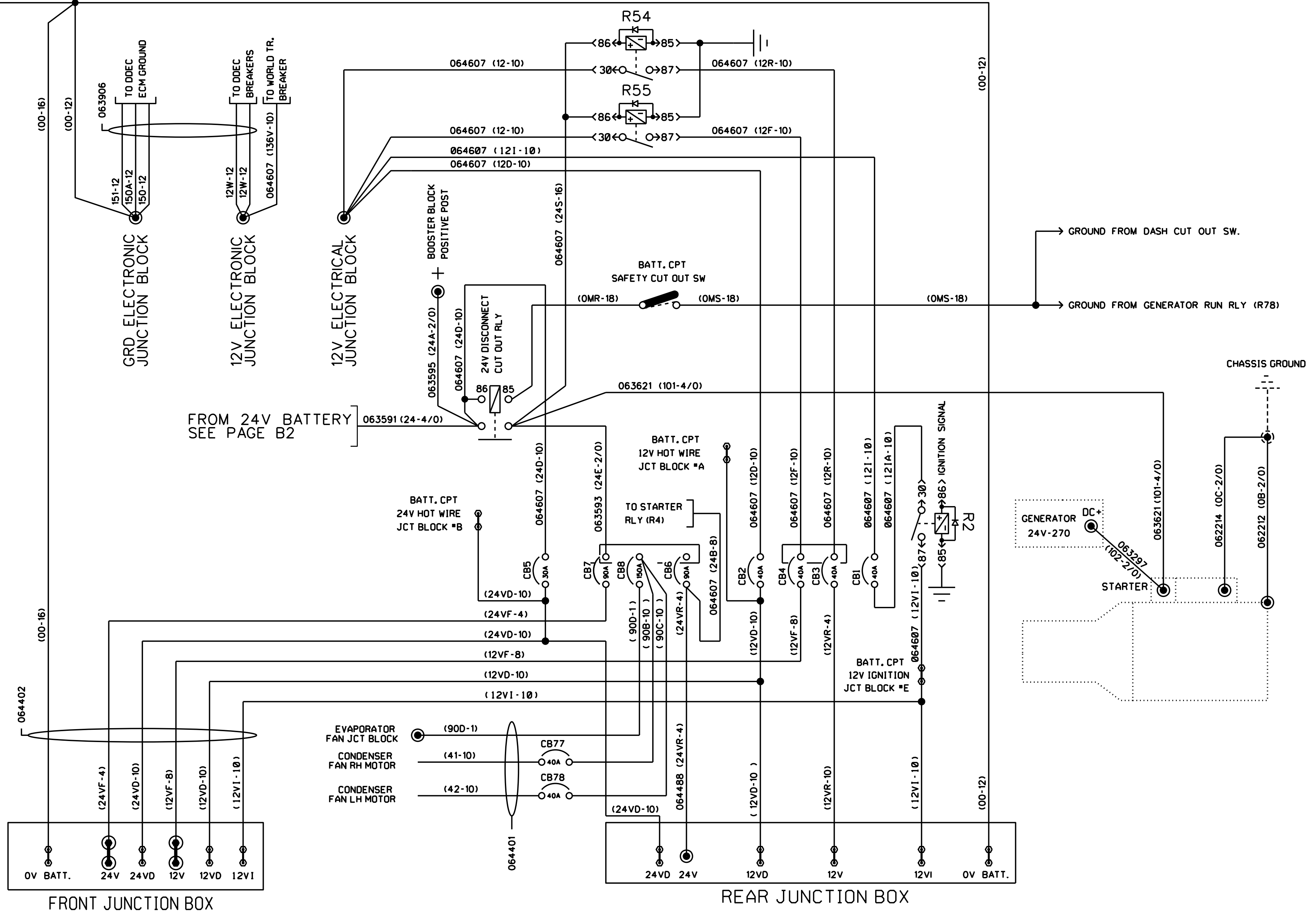

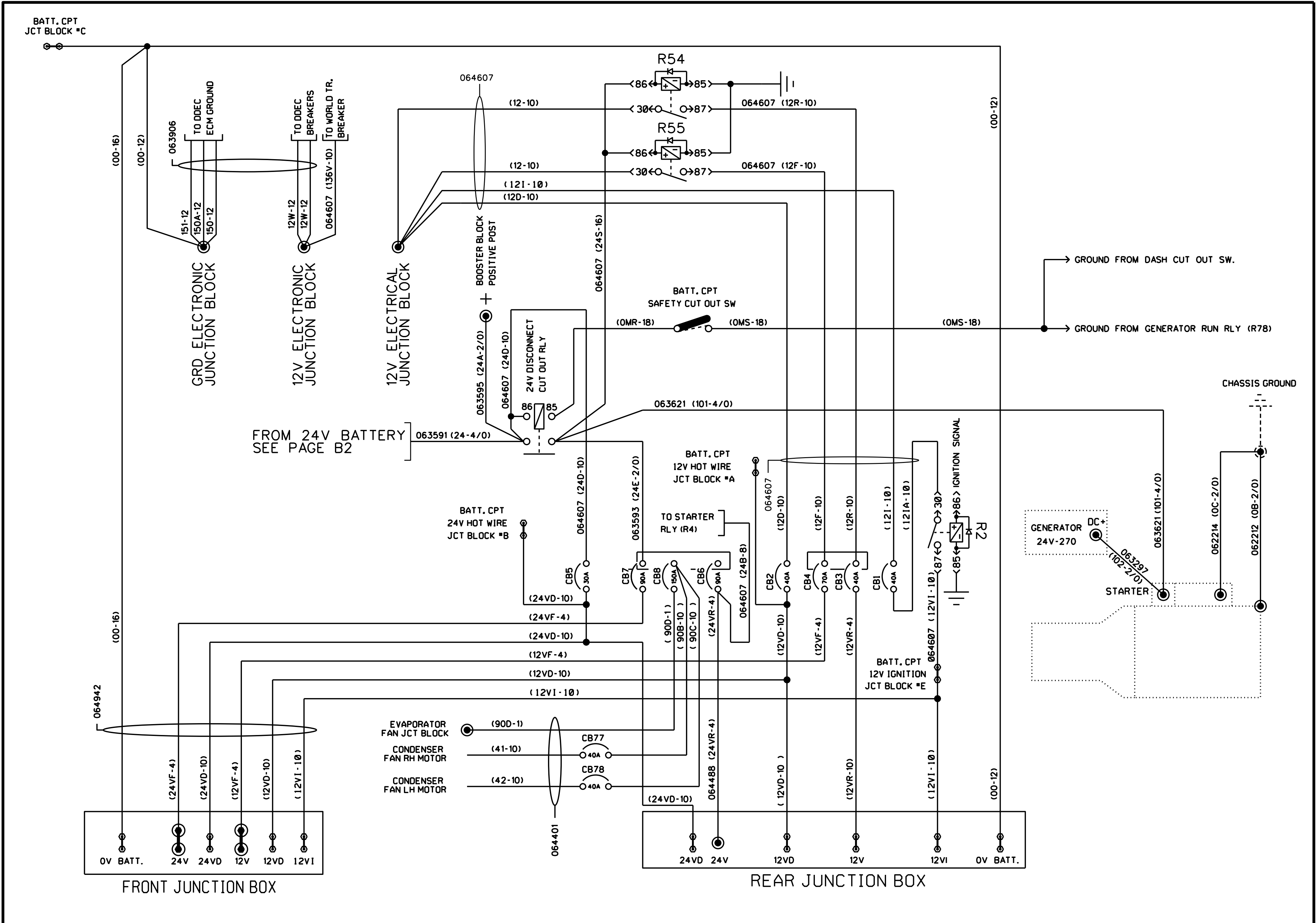

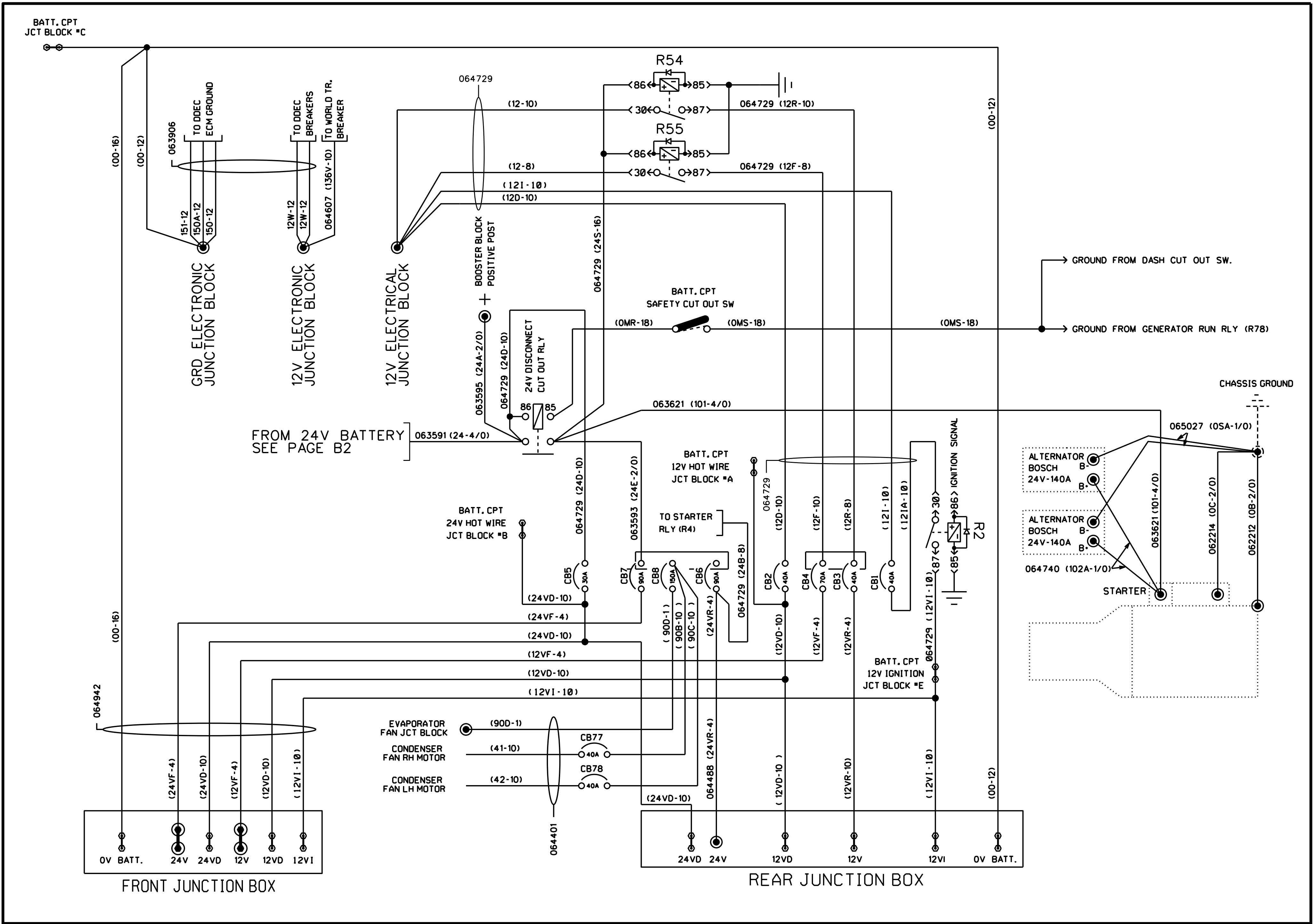

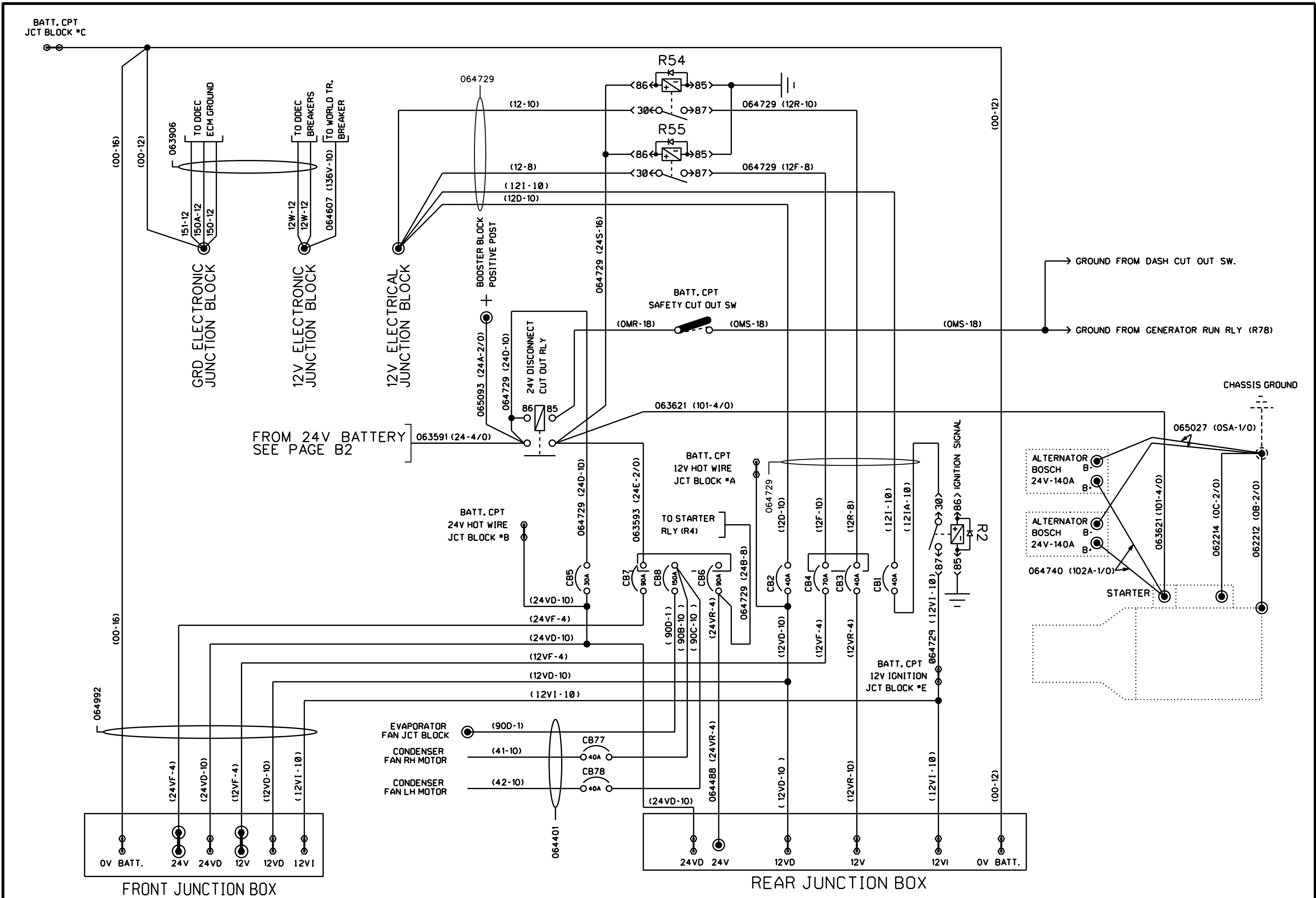



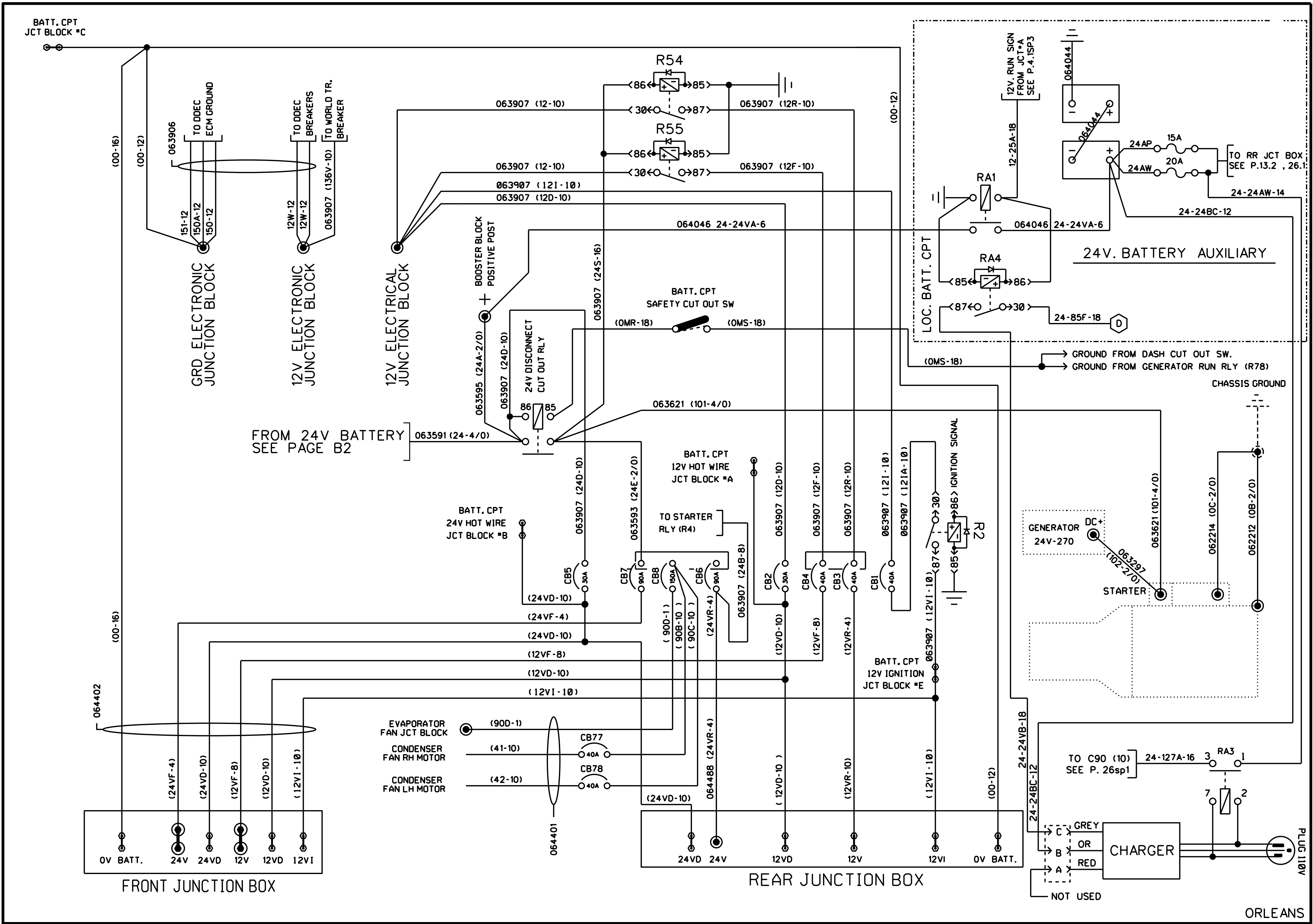

BATT. CPT  
JCT BLOCK #C

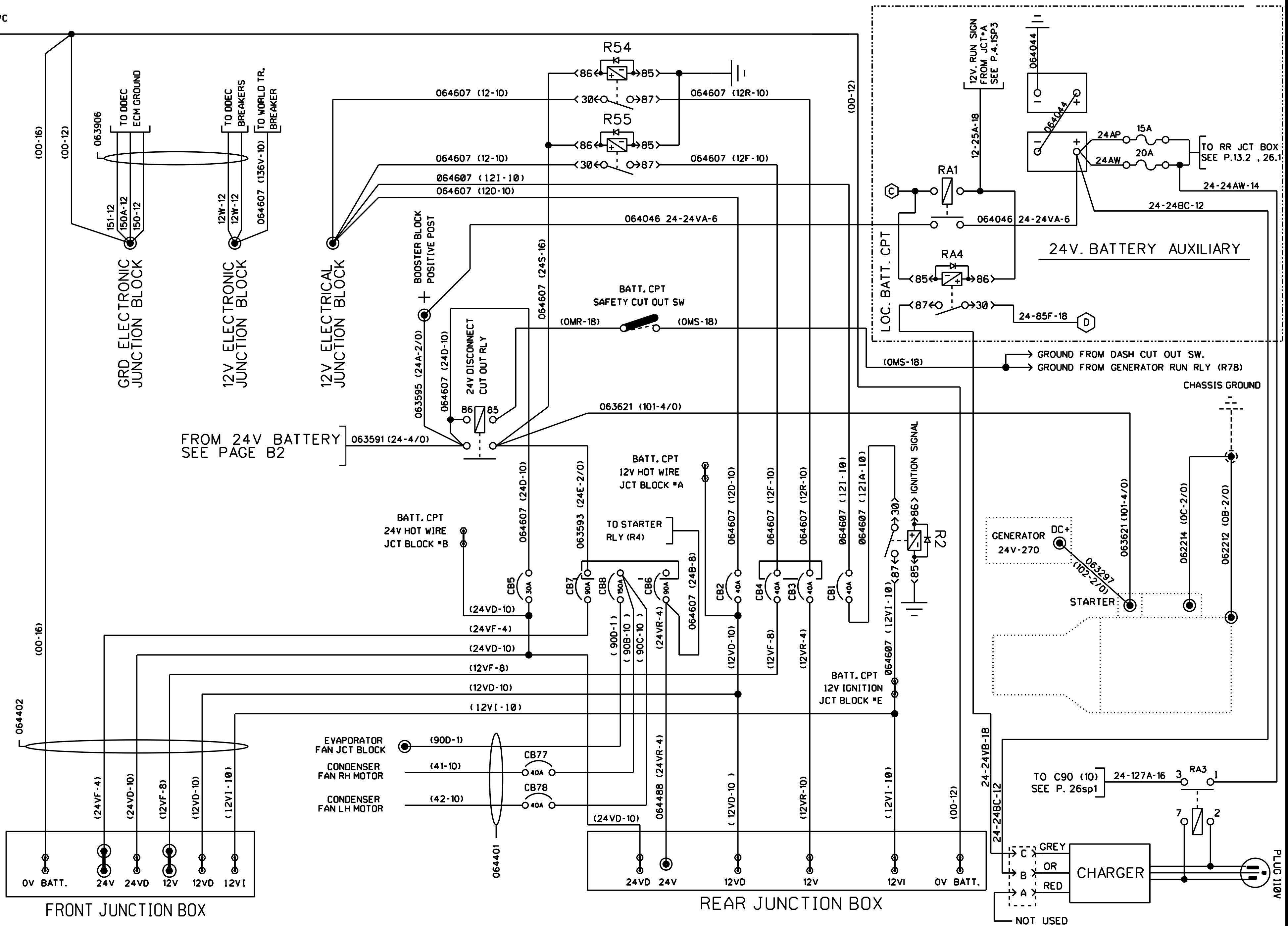

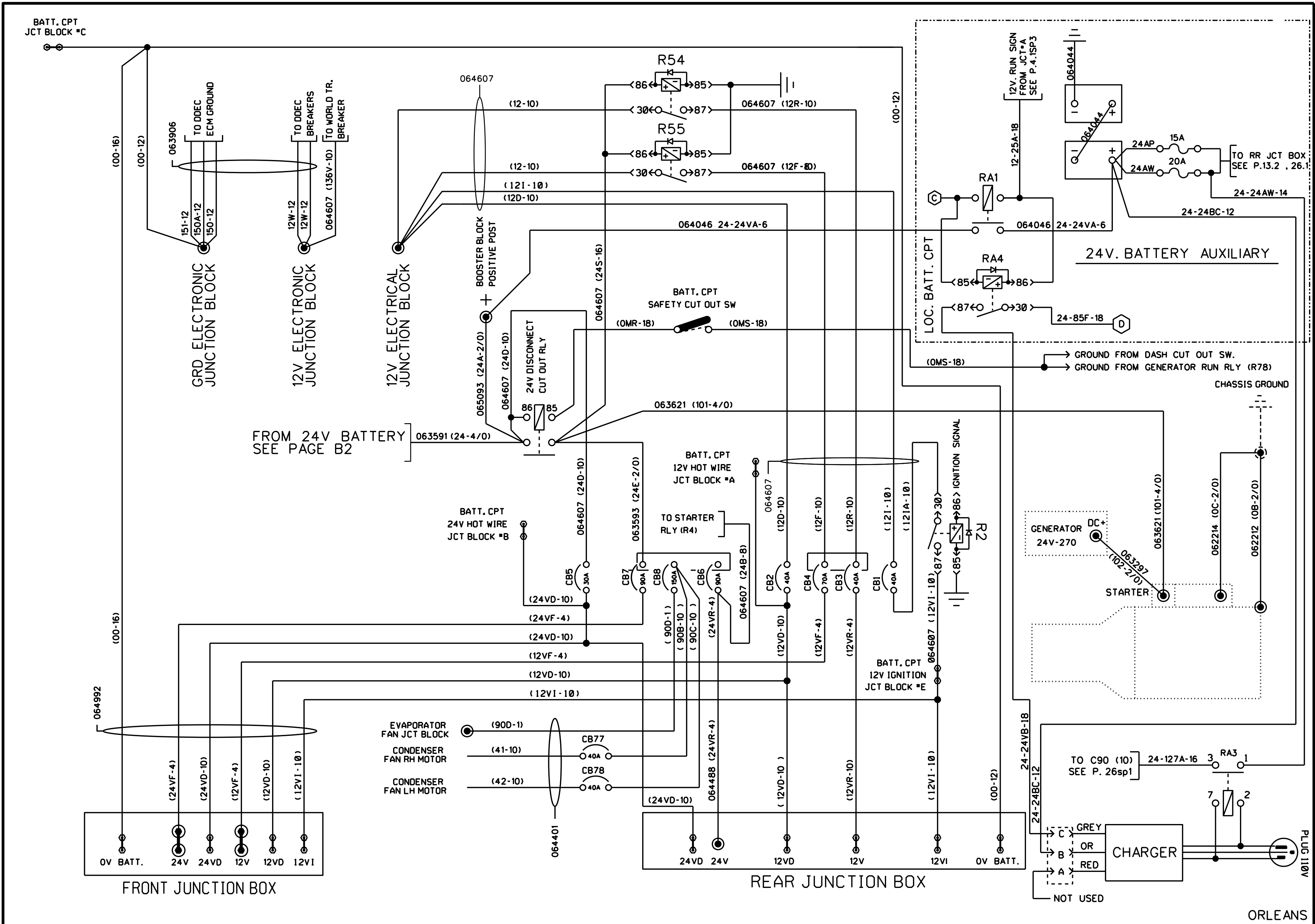

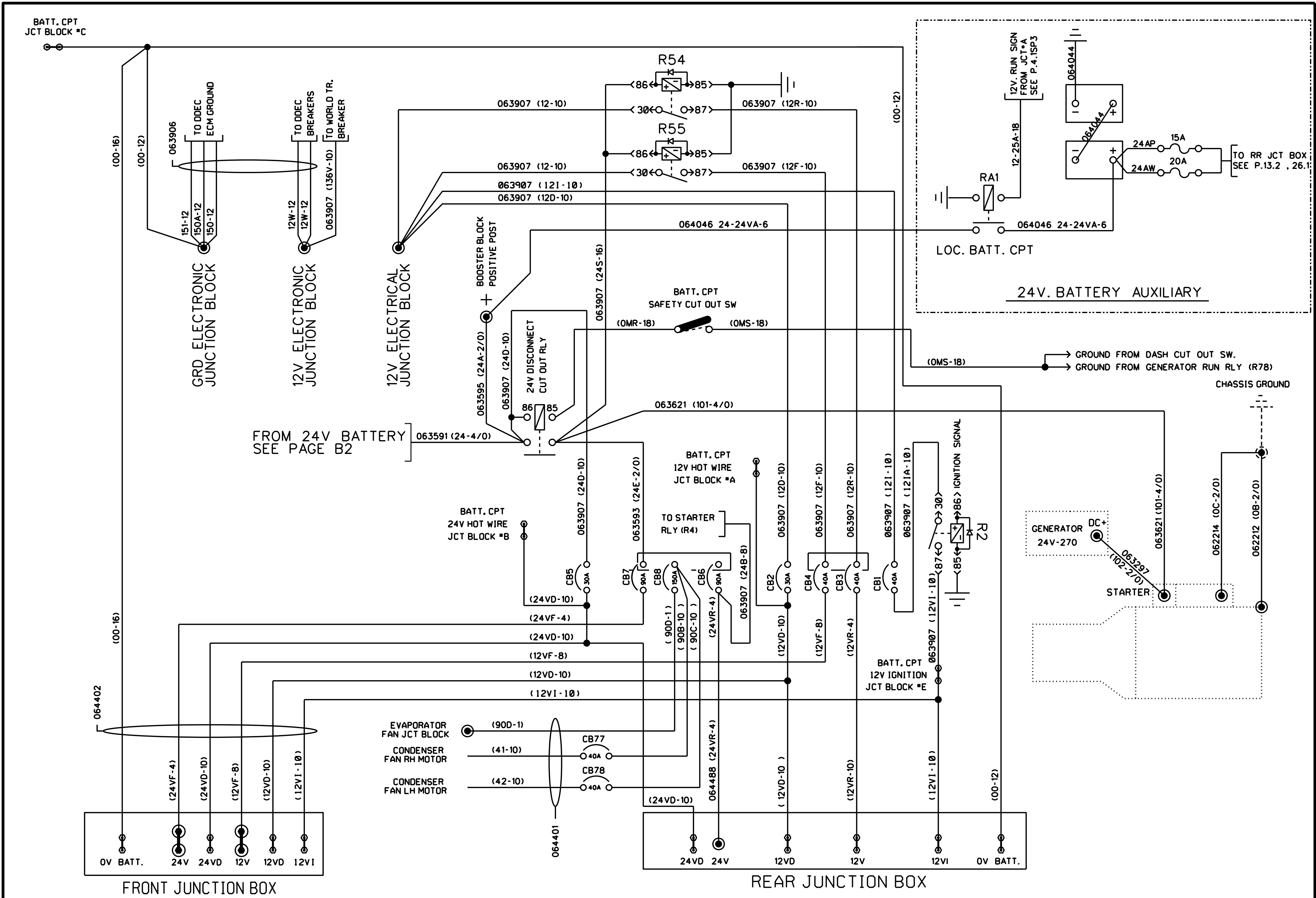

ADIRONDACK

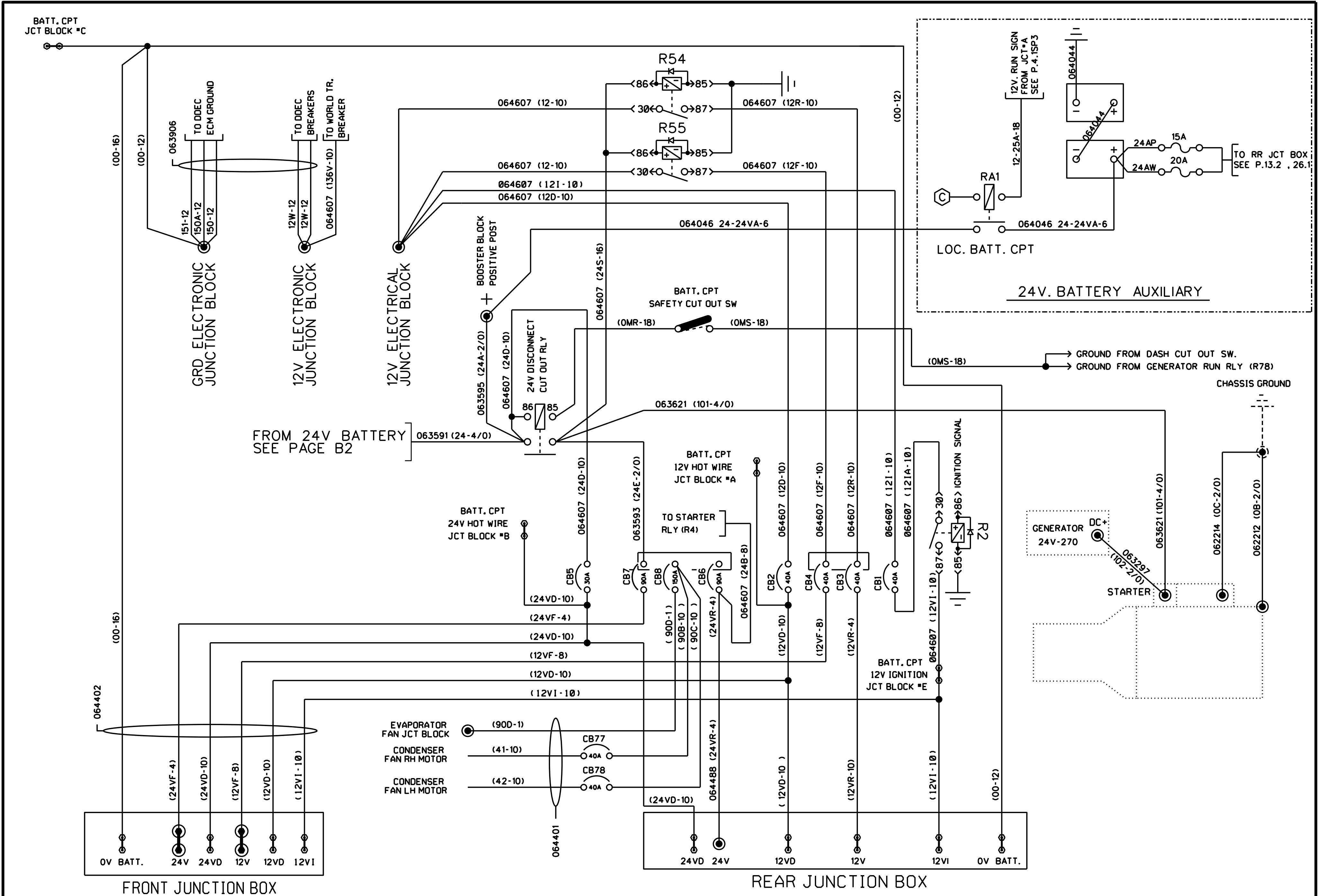

ADIRONDACK

BATT. CPT  
JCT BLOCK #C

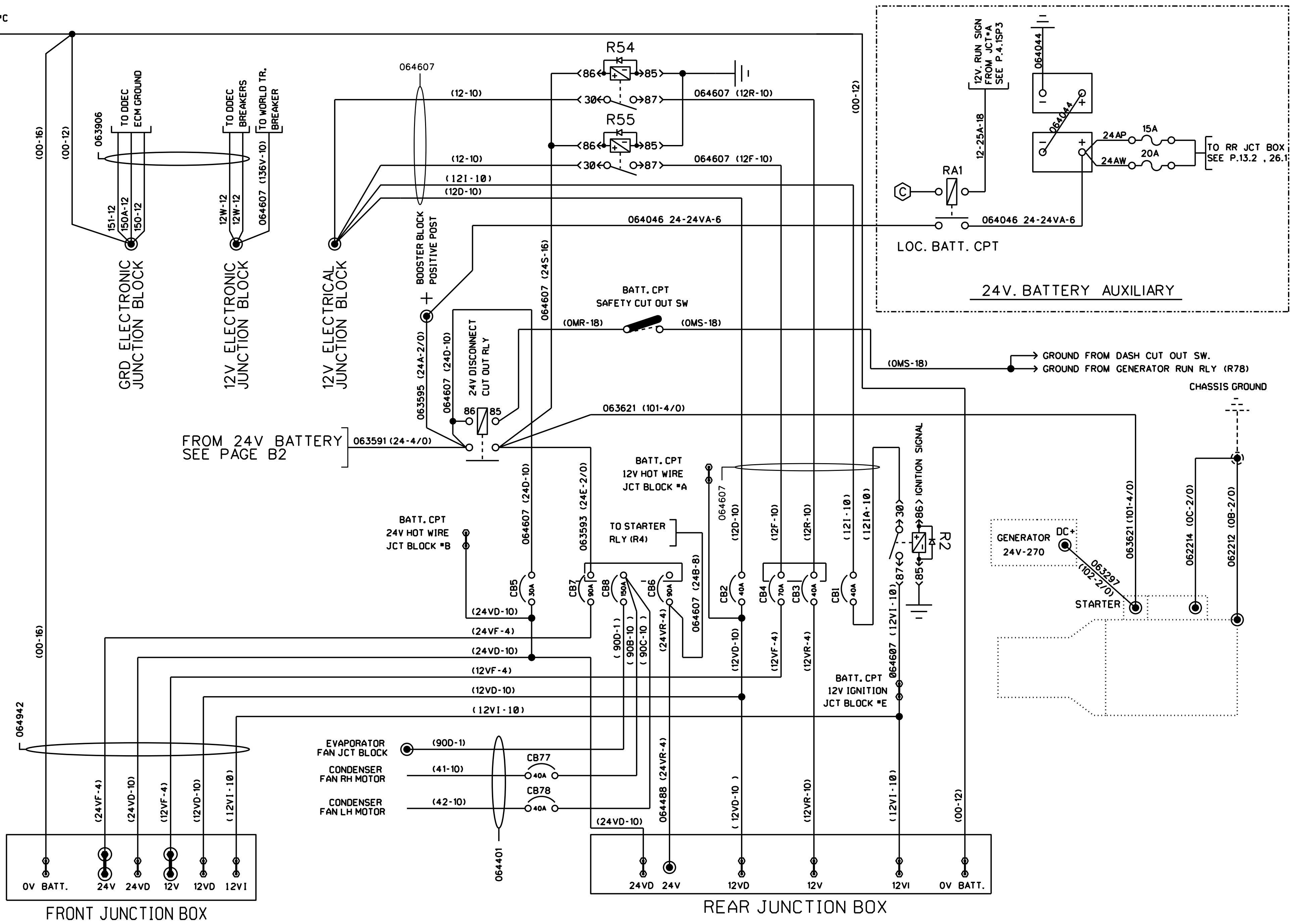

FRONT JUNCTION BOX

REAR JUNCTION BOX

ADIRONDACK

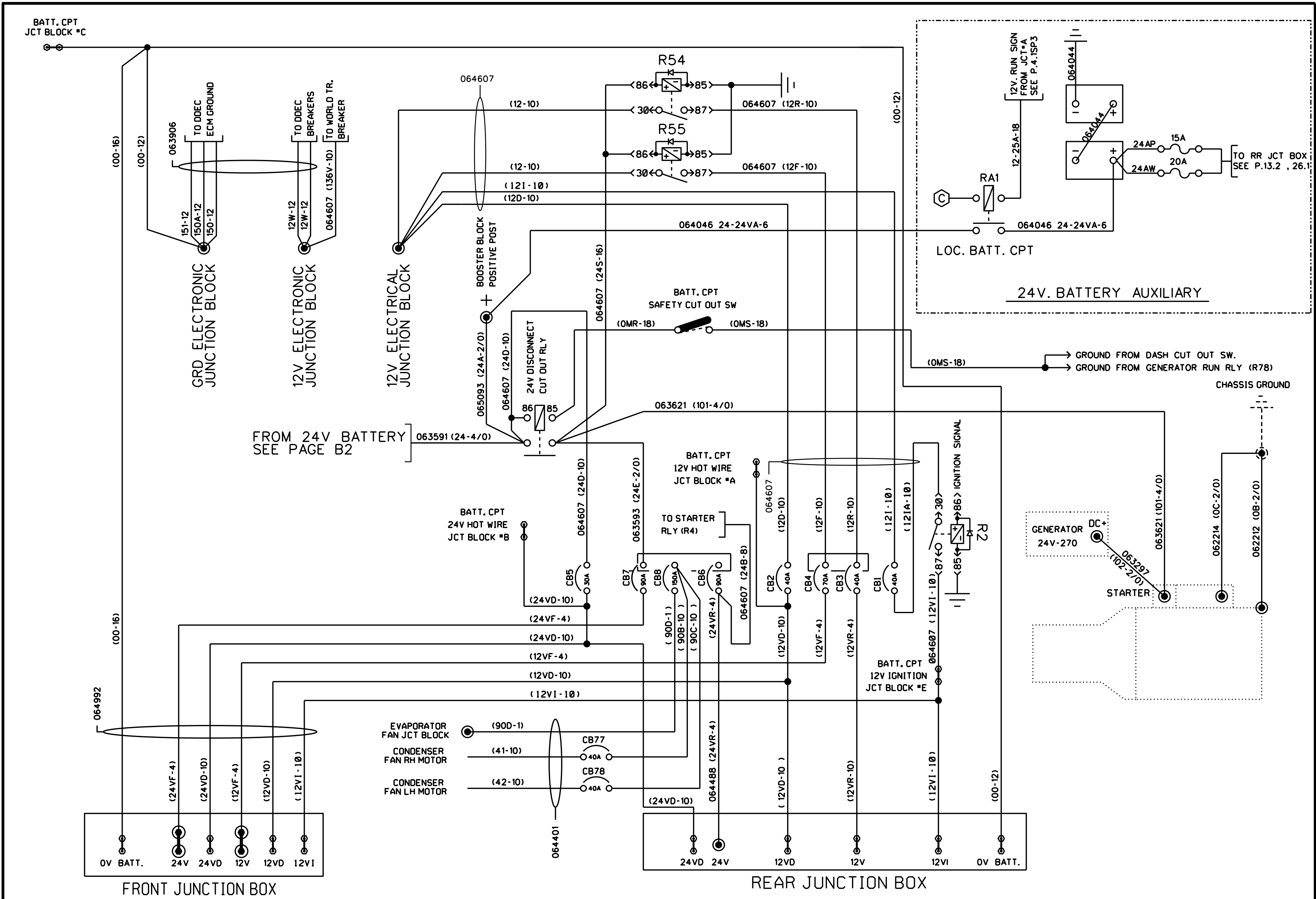

ADIRONDACK

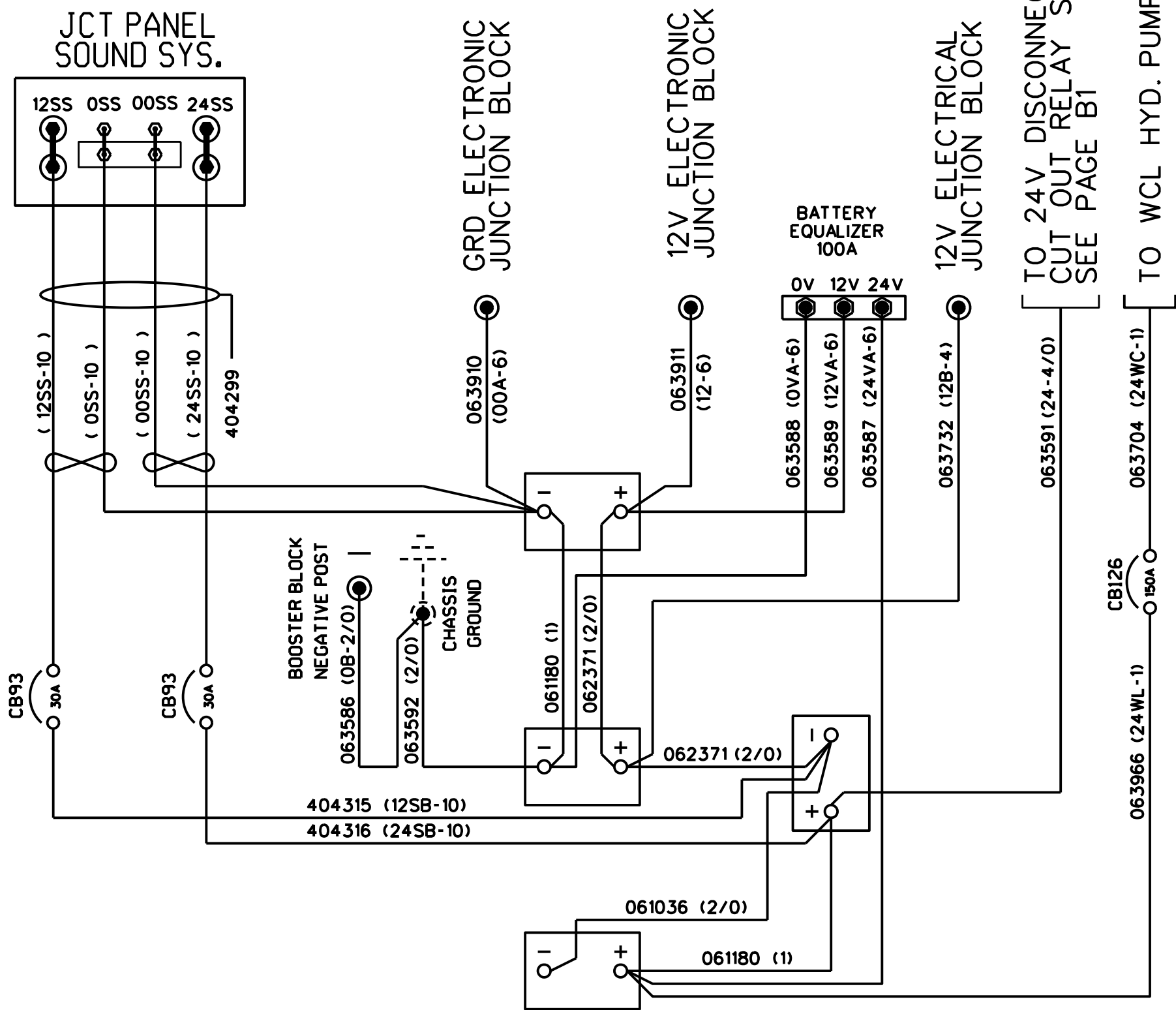

STANDARD BATTERIES

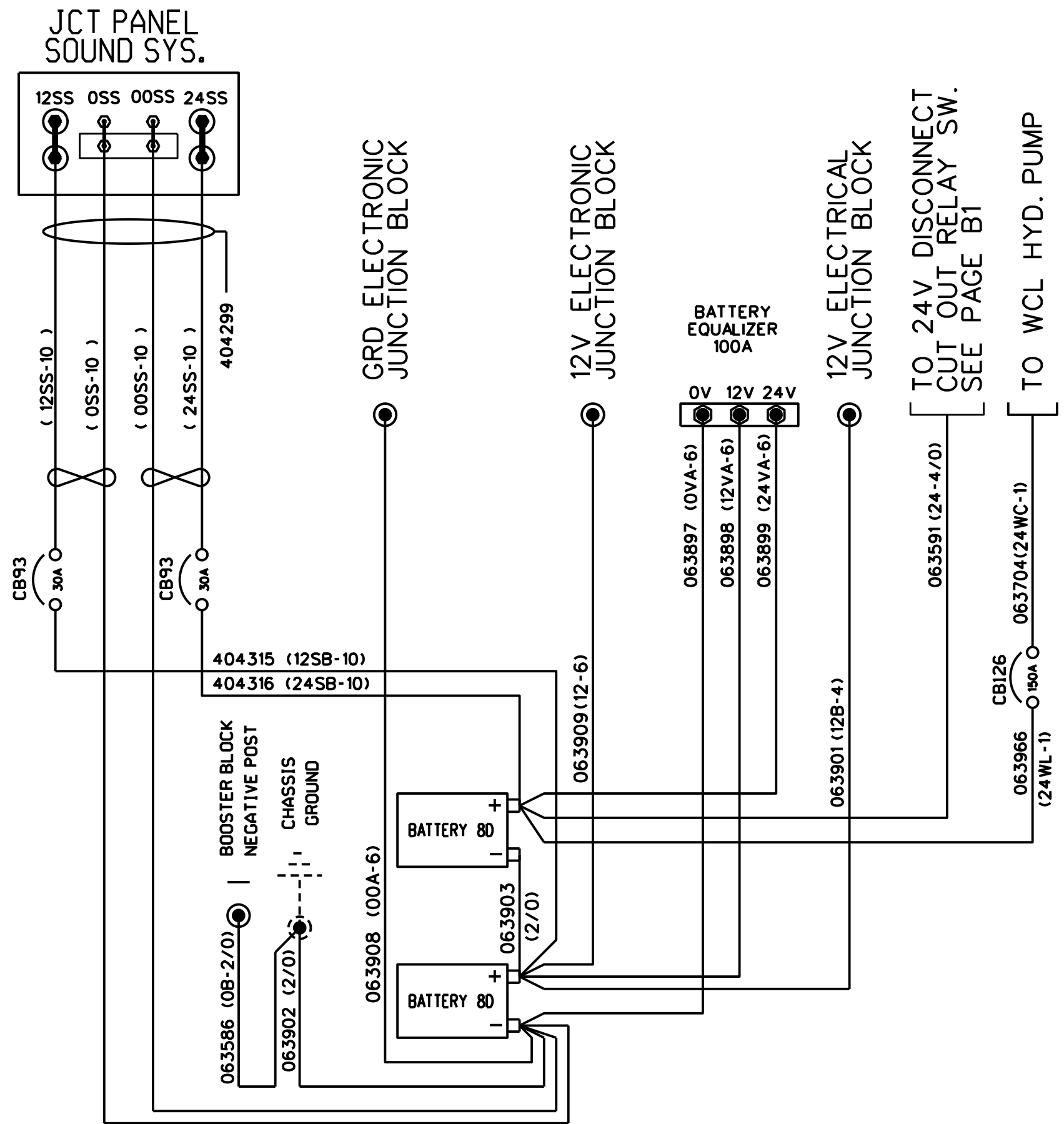

8D BATTERIES



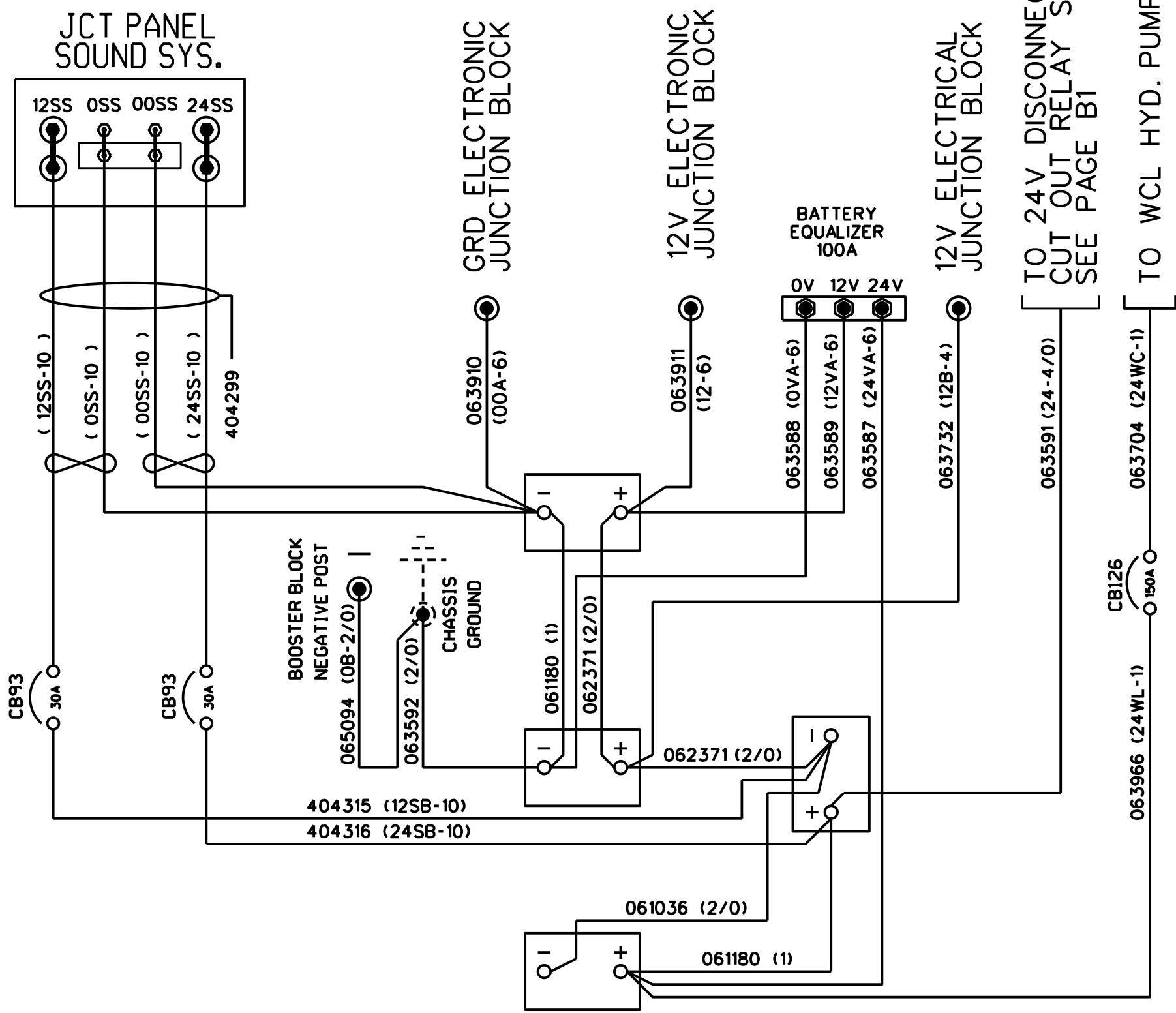

STANDARD BATTERIES

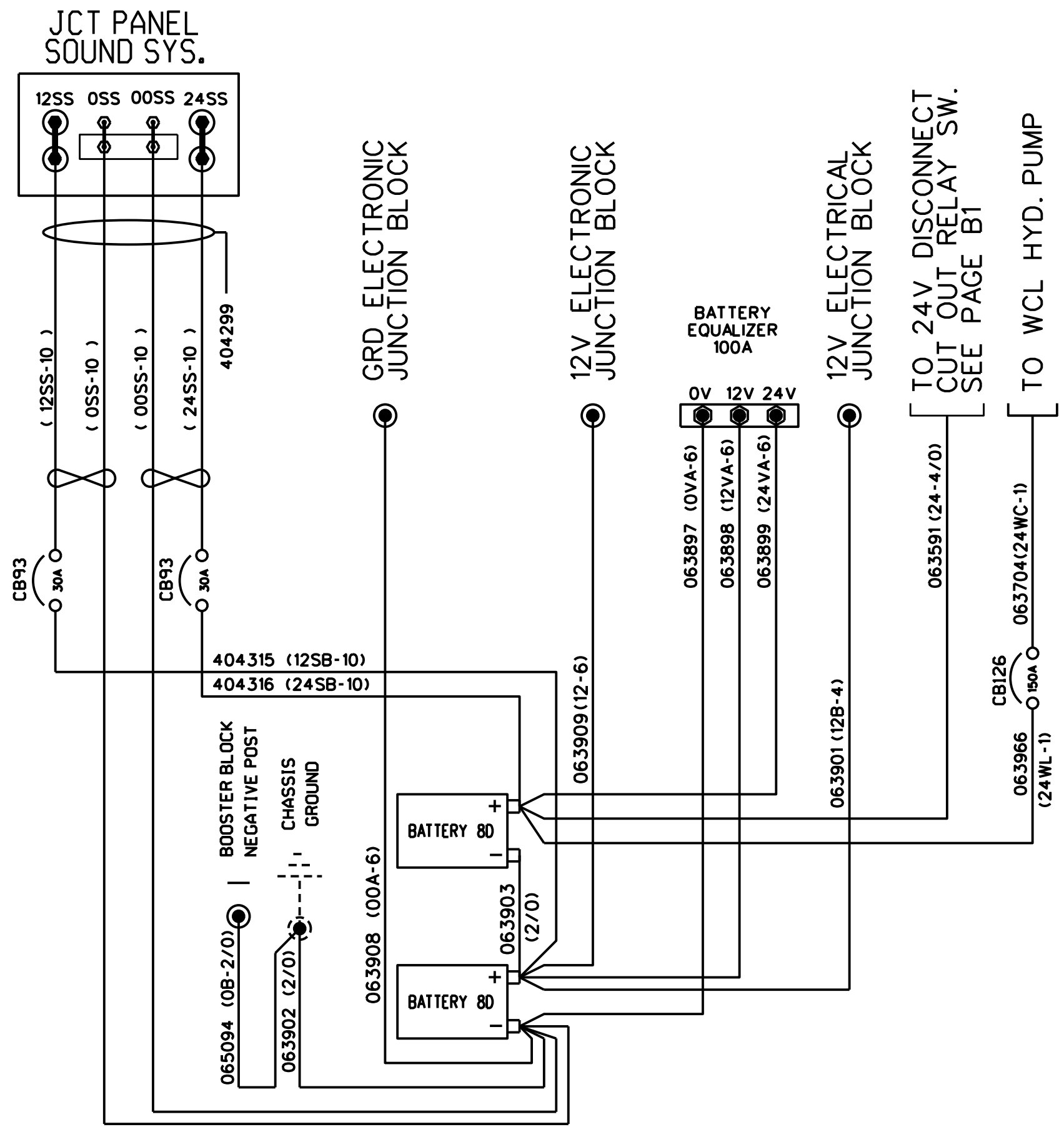

8D BATTERIES

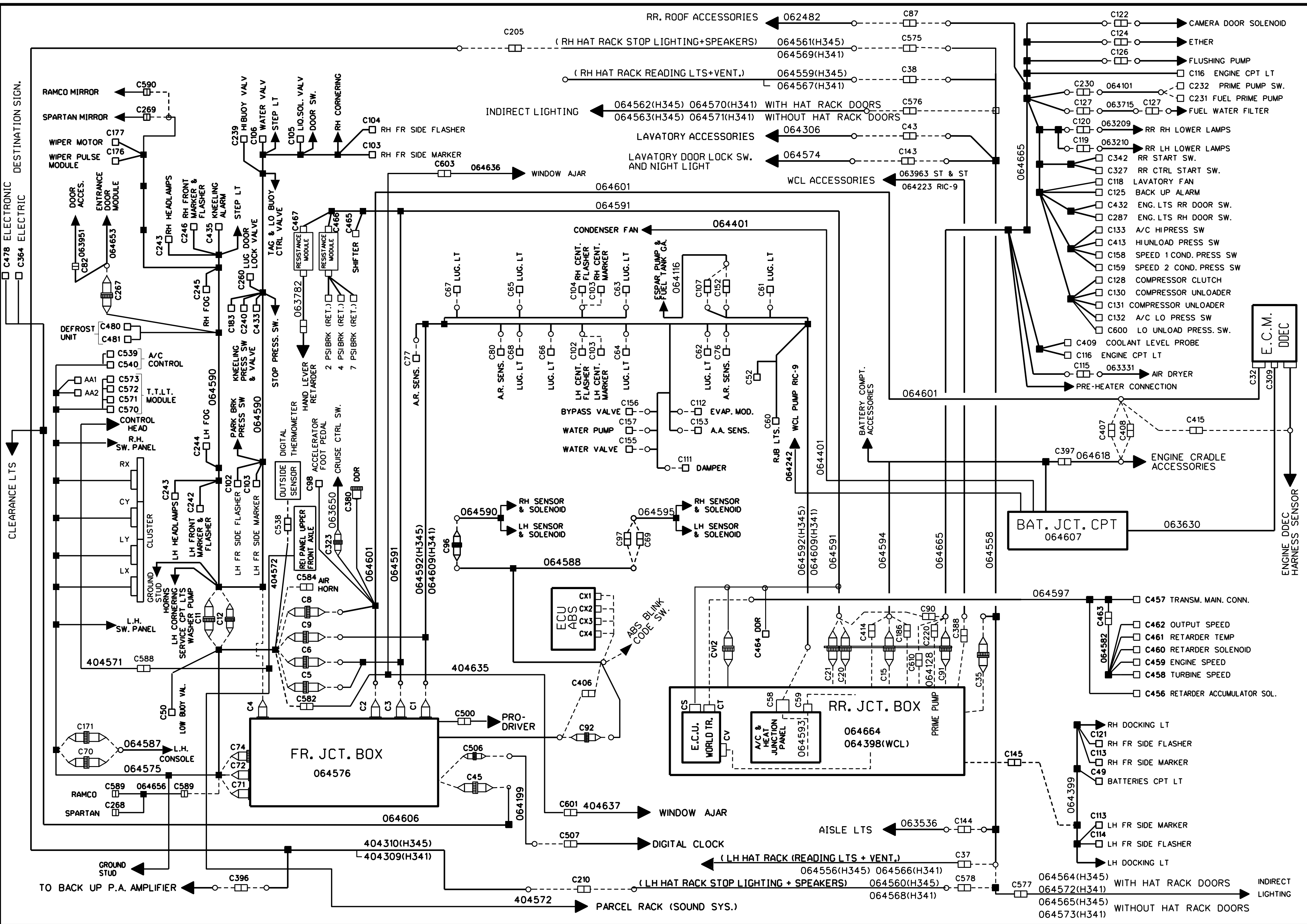

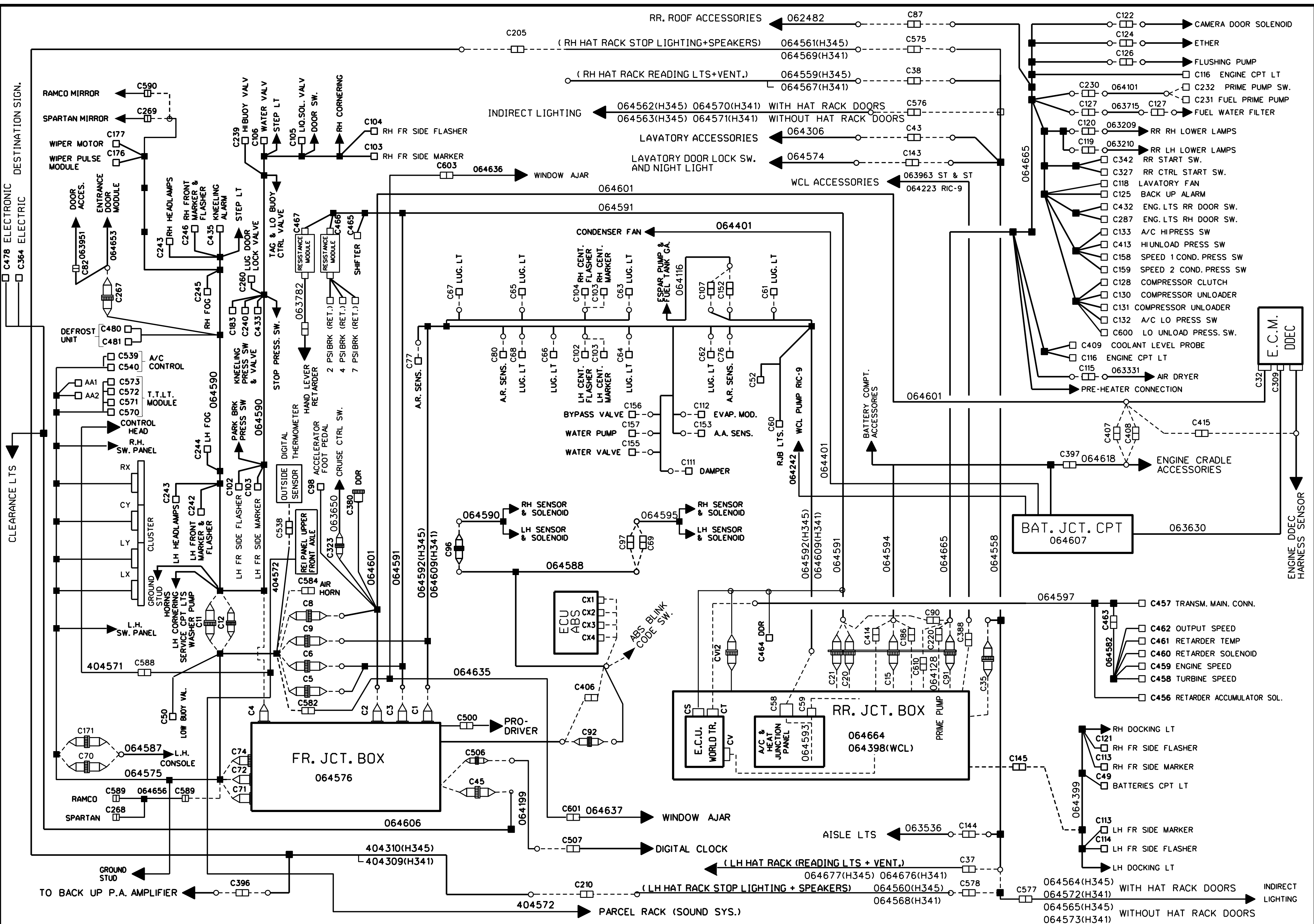

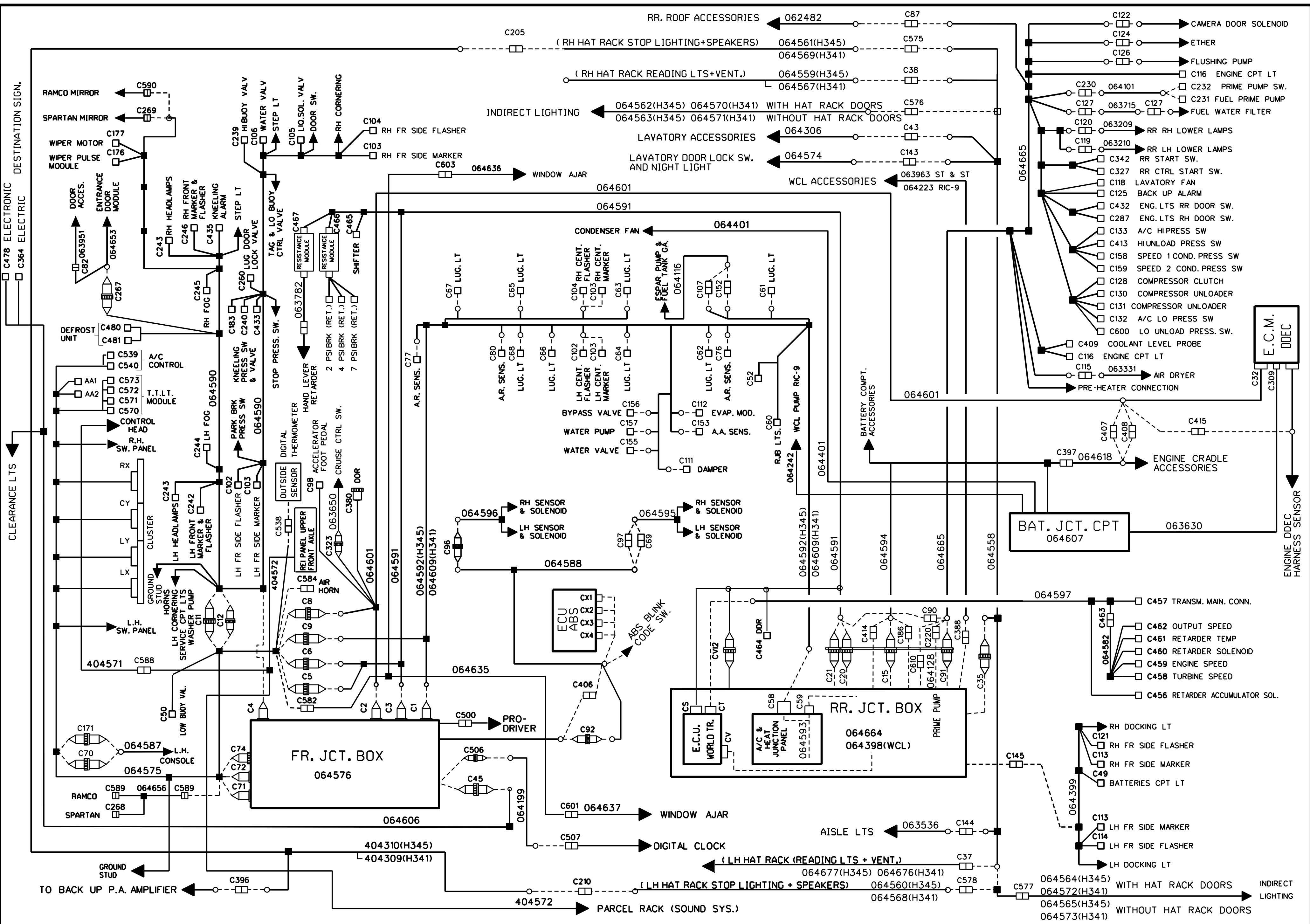

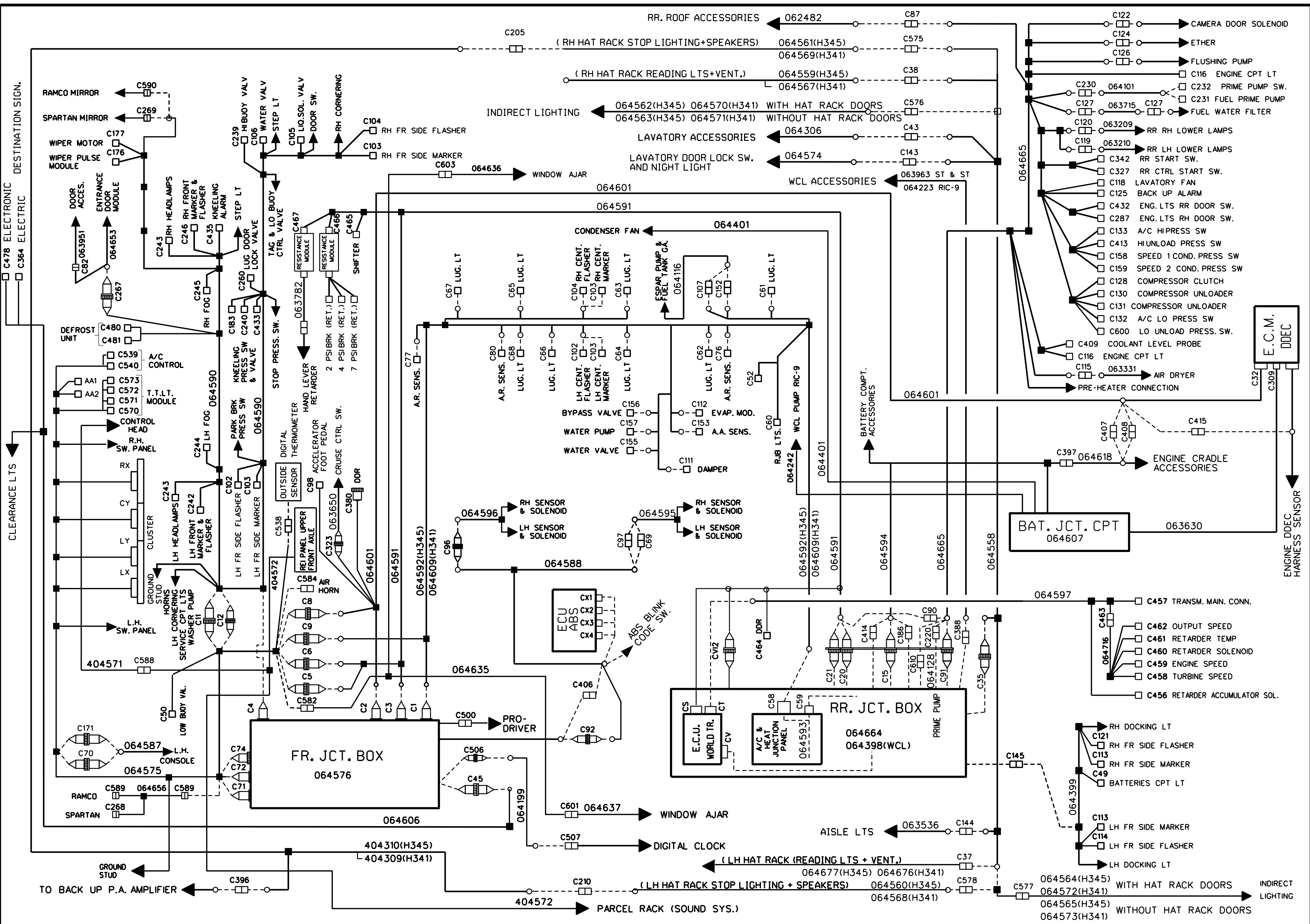



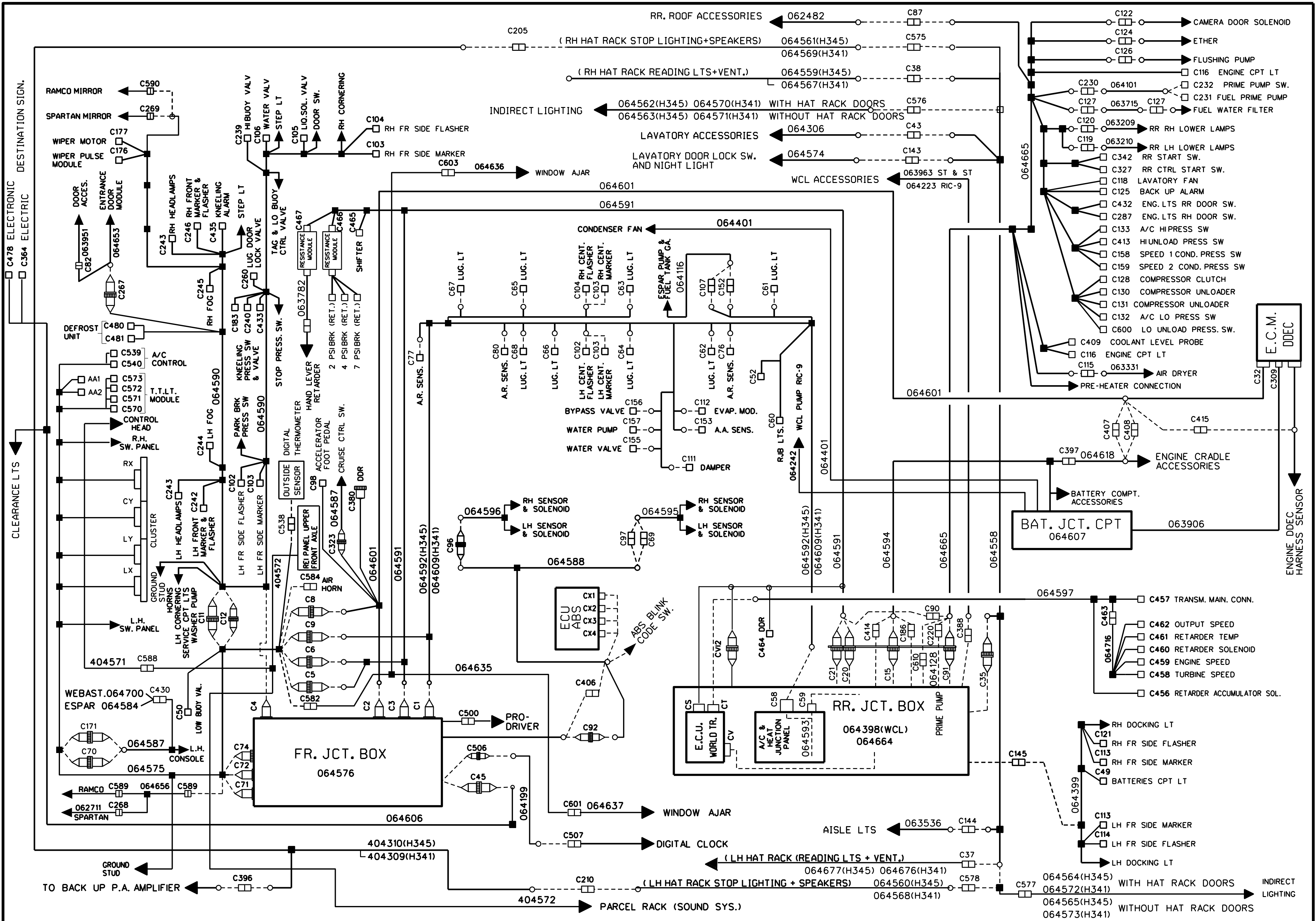

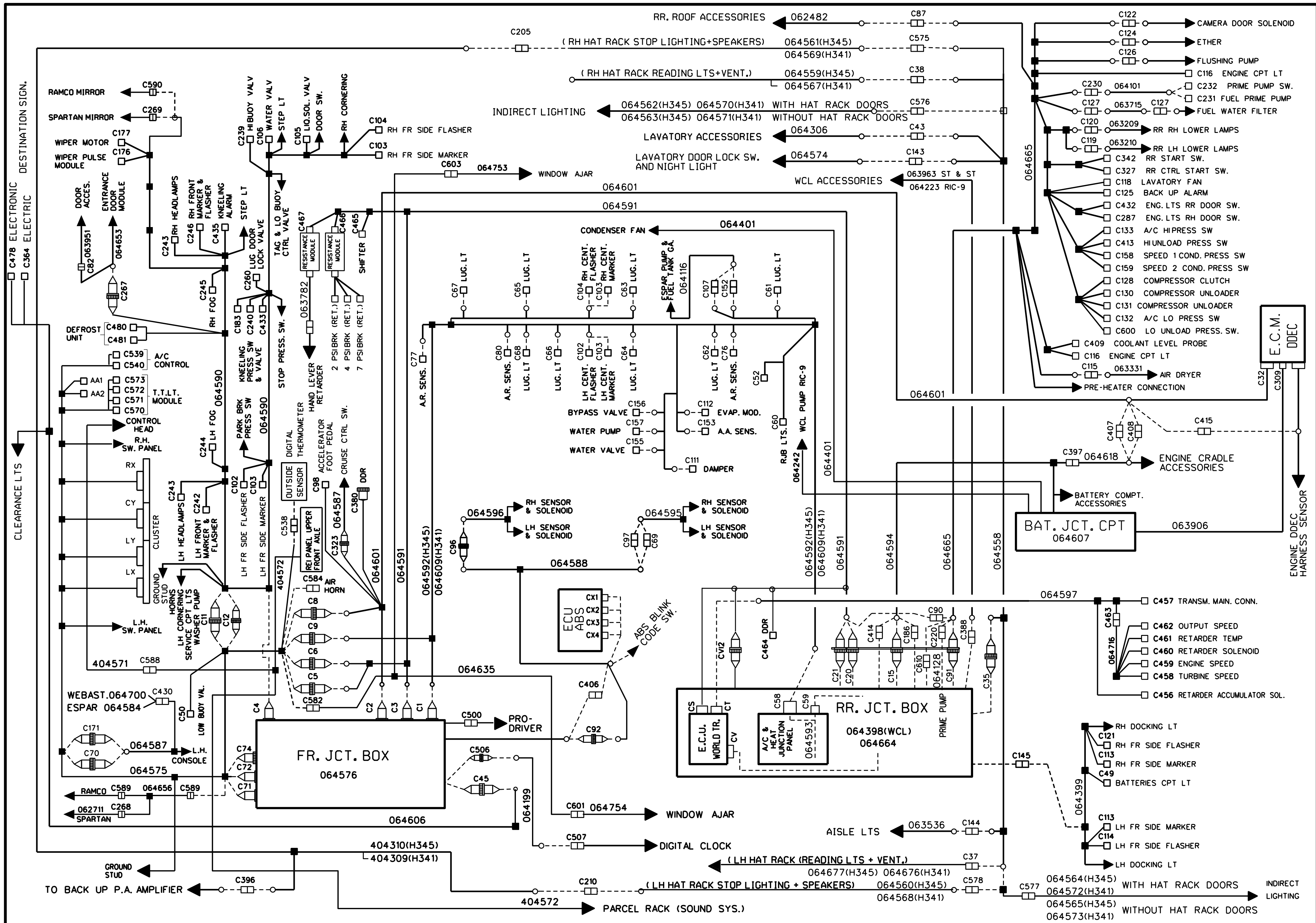

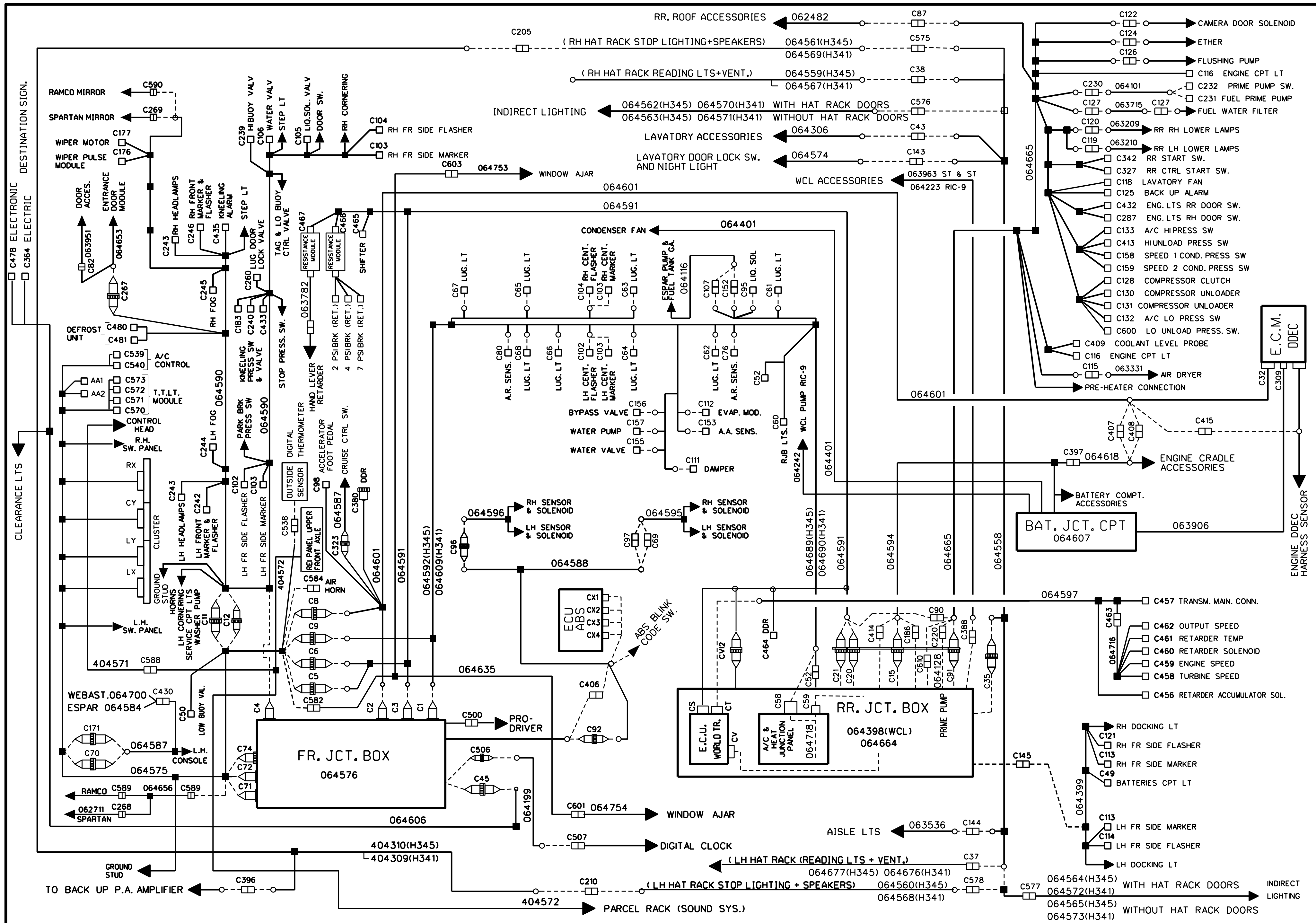



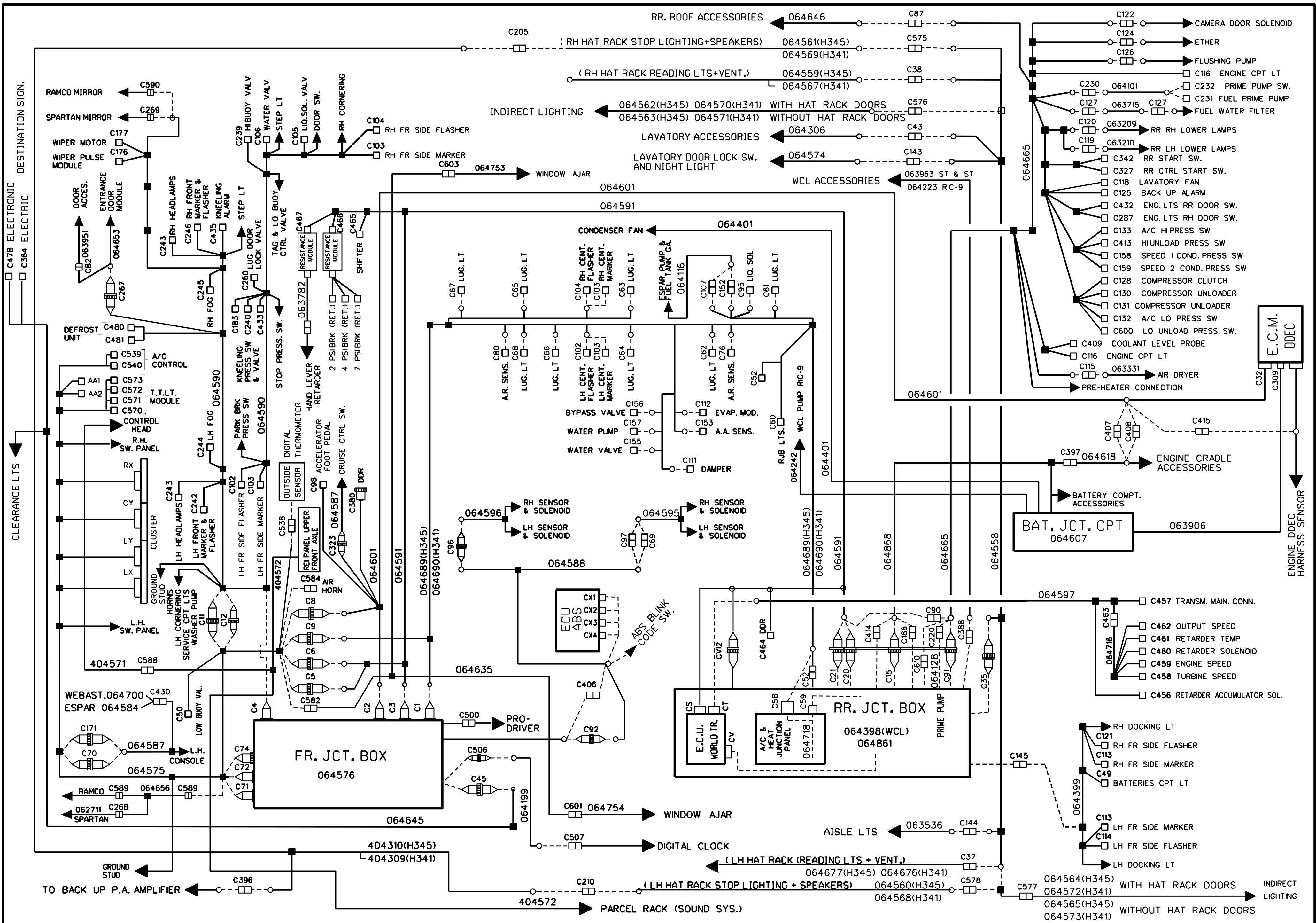

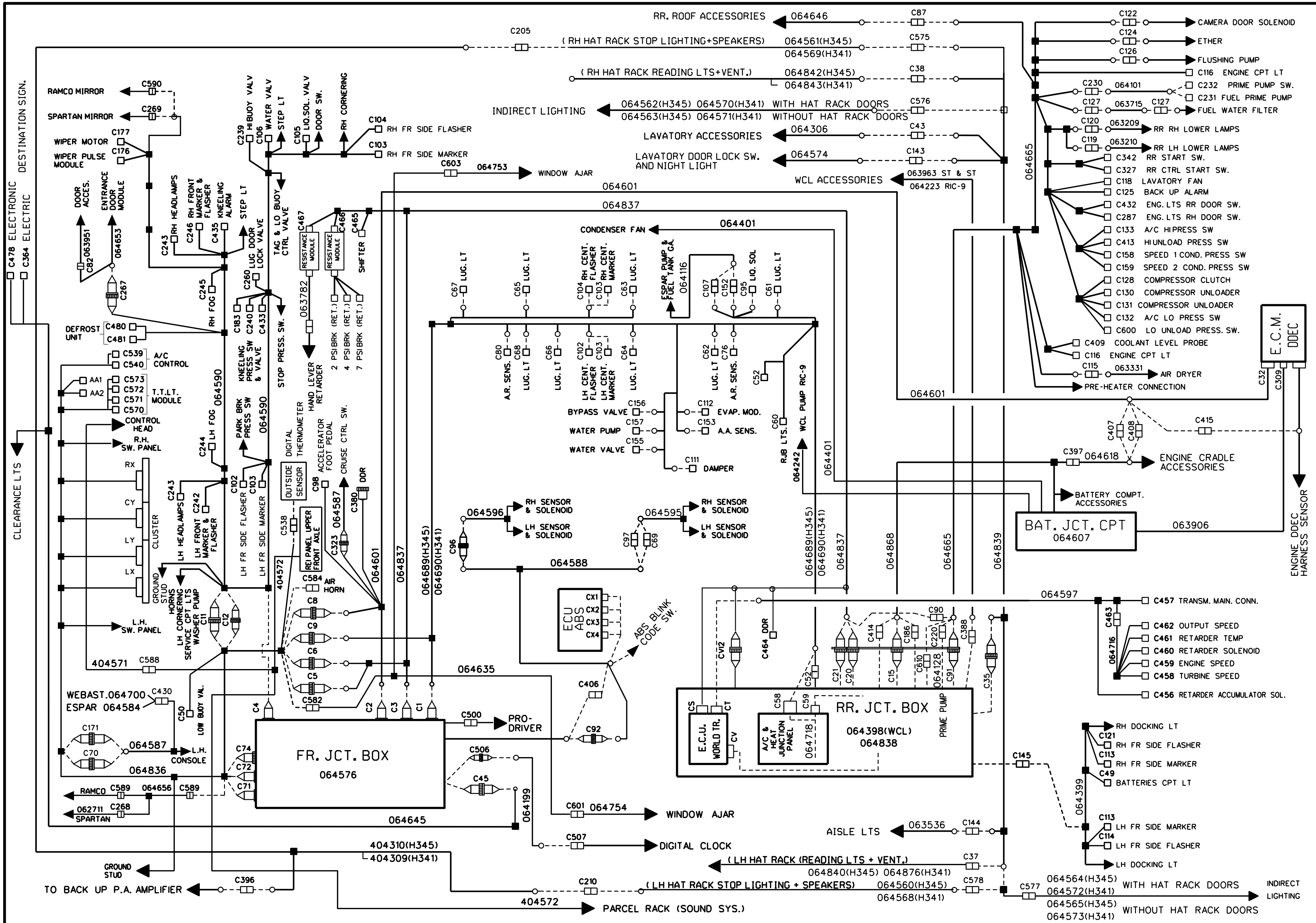

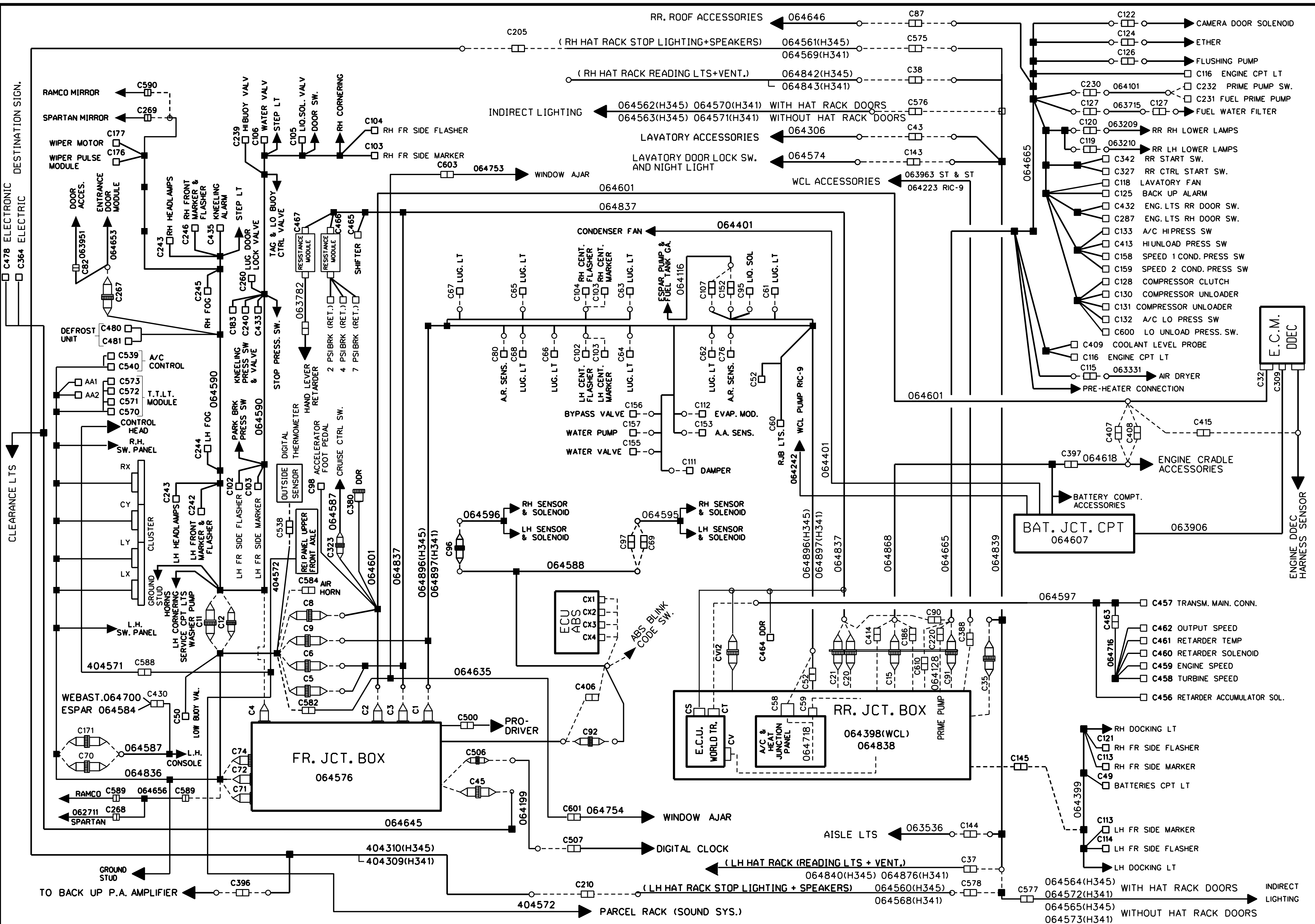

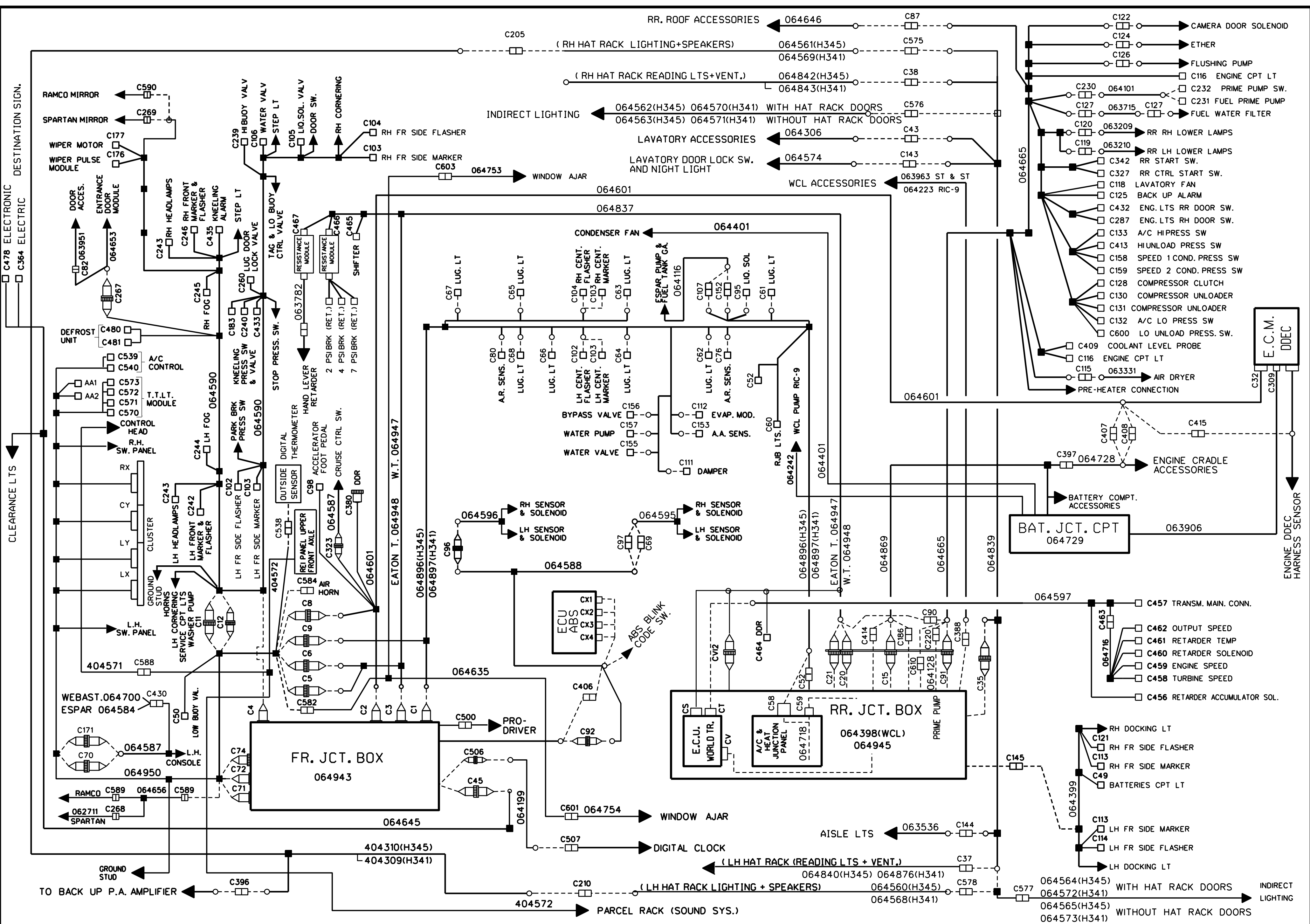

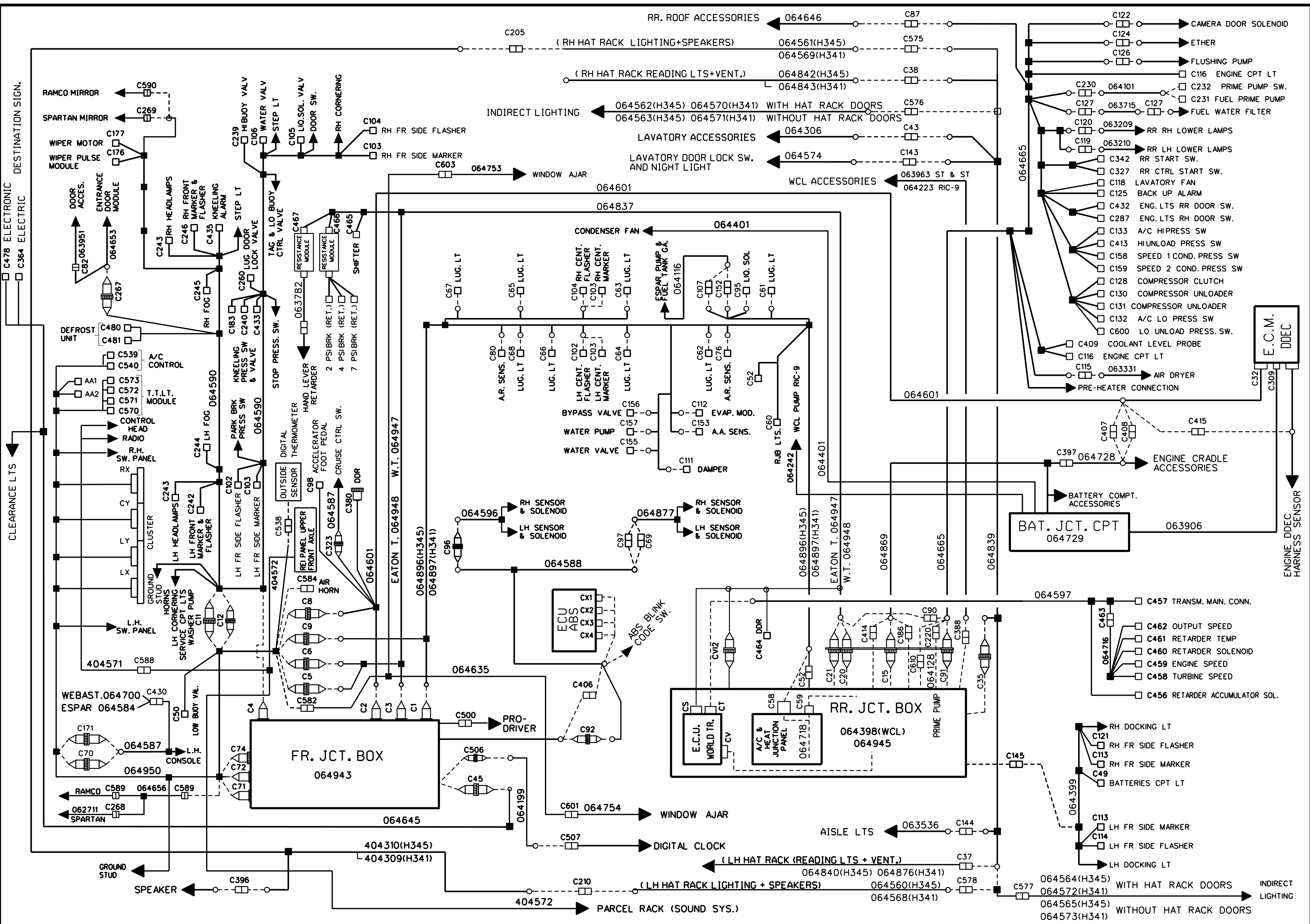



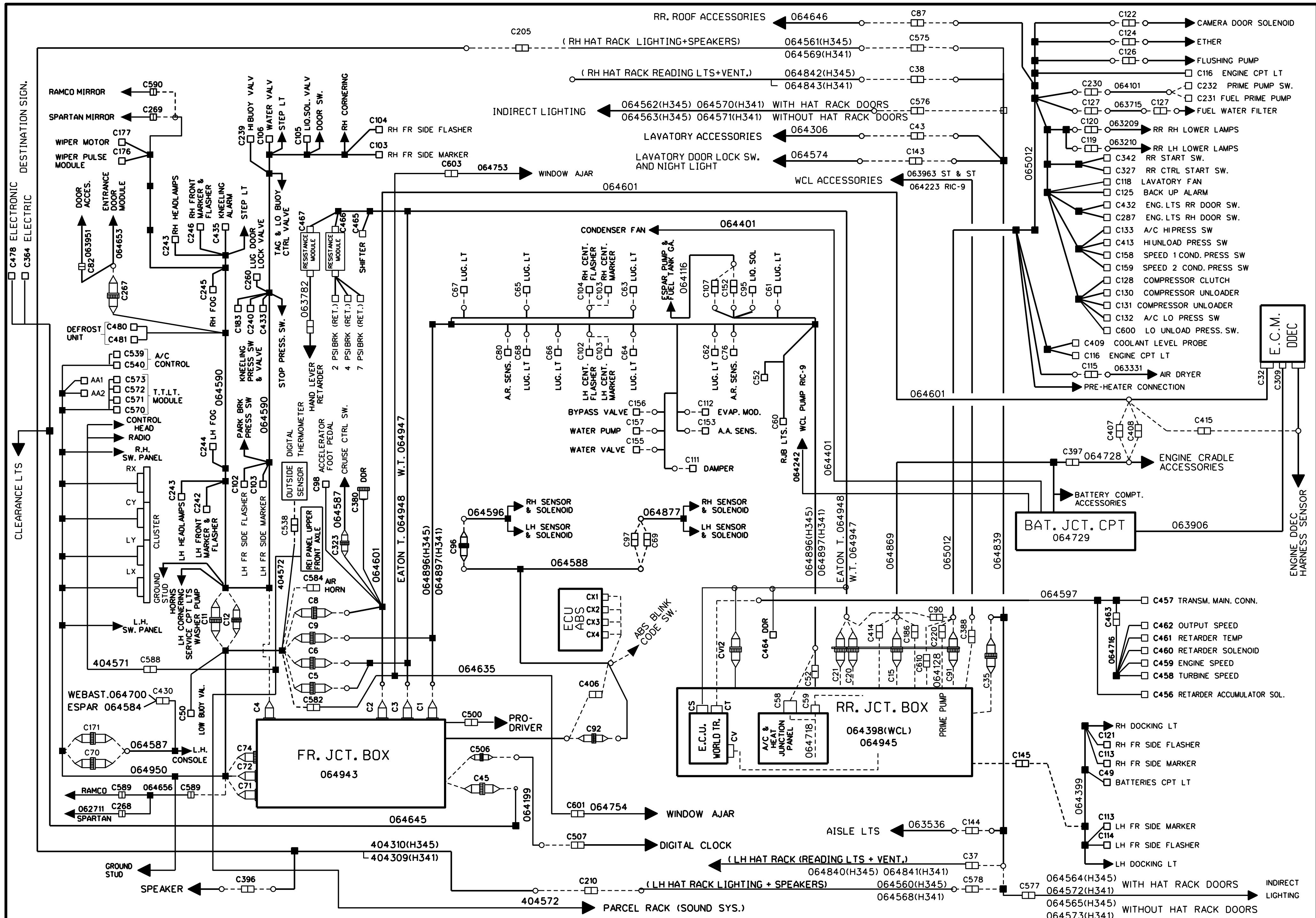

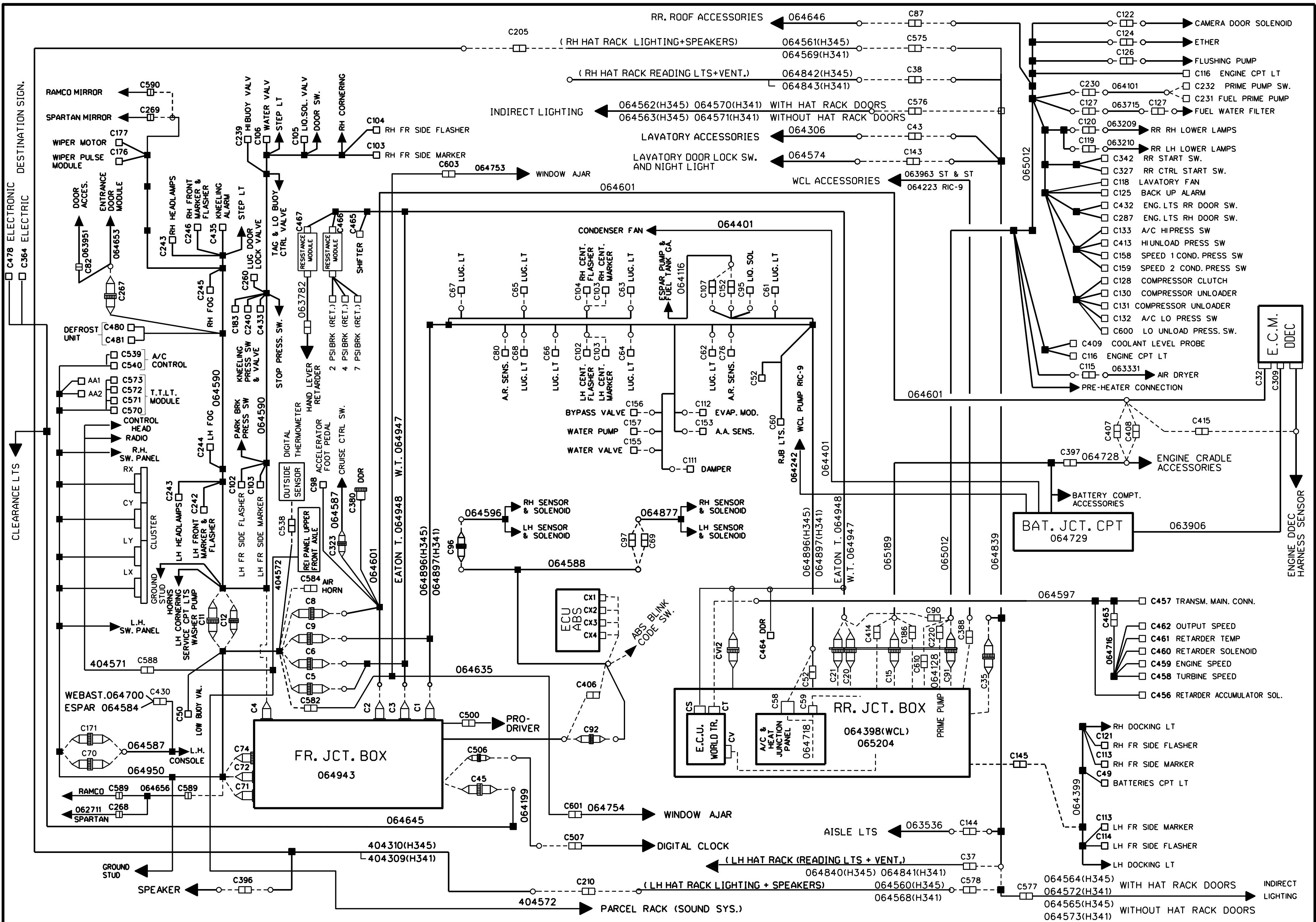

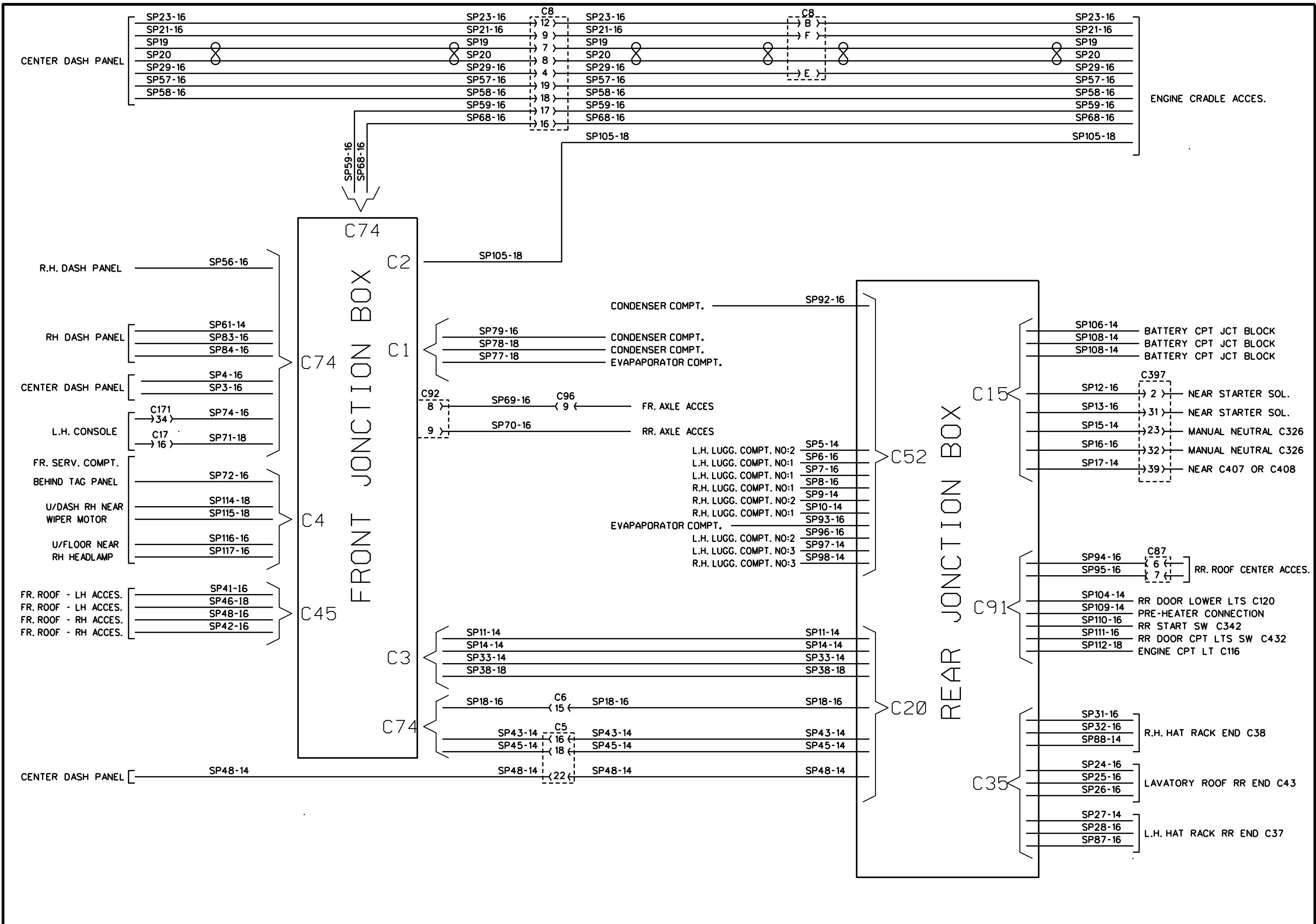



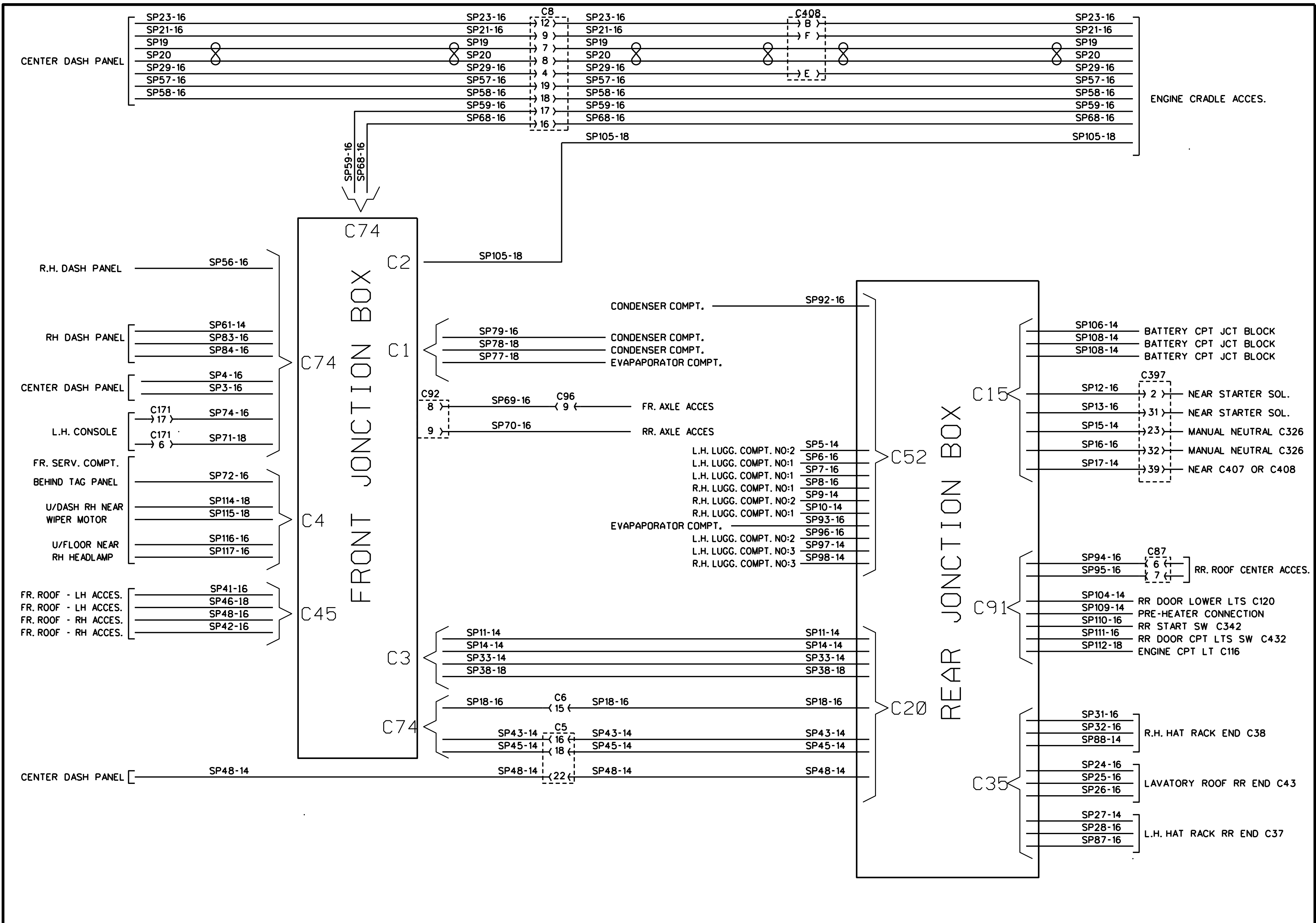

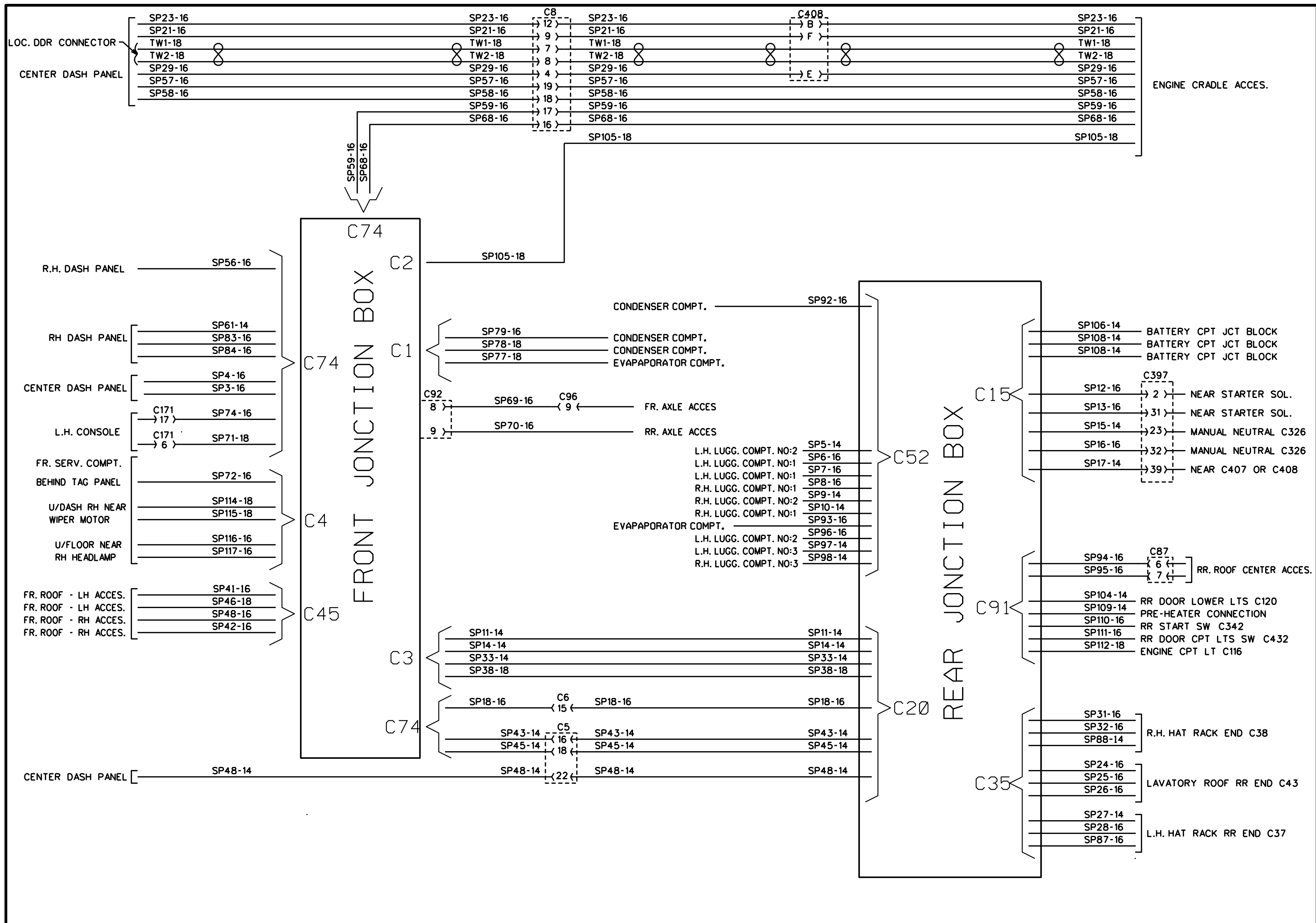

# CIRCUIT NUMBER CODE

No.	DESCRIPTION	No.	DESCRIPTION	No.	DESCRIPTION	No.	DESCRIPTION
B A	INTERIOR LTS-110V FLUORESCENT	S P 15	SPARE-RJB TO ENGINE	S P 115	SPARE-FJB TO U/DASH WIPER	0 M3	FS - ELECTRICAL MOTOR GRD
B B	INTERIOR LTS-110V FLUORESCENT	S P 16	SPARE-RJB TO ENGINE	S P 116	SPARE-FJB TO U/DASH FLOOR	0 M4	FS - ELECTRICAL MOTOR GRD
D 1	SOUND SYSTEM-FR RH SPEAKER	S P 17	SPARE-RJB TO ENGINE	S P 117	SPARE-FJB TO U/DASH FLOOR	0 M5	FS - ELECTRICAL MOTOR GRD
D 2	SOUND SYSTEM-FR RH SPEAKER	S P 18	SPARE-FJB TO RJB	W C	A/C & HEAT SYST-EVAP CTR SIGN	0 M6	FS - FJB GRD
D 3	SOUND SYSTEM-RR RH SPEAKER	S P 24	SPARE-RJB TO LAVATORY ROOF	Y C	INTERIOR LTS-110V FLUORESCENT	0 M7	FS - ELECTRICAL MOTOR GRD
D 4	SOUND SYSTEM-RR RH SPEAKER	S P 25	SPARE-RJB TO LAVATORY ROOF	Y D	INTERIOR LTS-110V FLUORESCENT	0 M	RS - ENGINE CPT ACCES. GRD
D 5	SOUND SYSTEM-RR RH SPEAKER	S P 26	SPARE-RJB TO LAVATORY ROOF	0	BC - BAT. CPT CHASSIS GRD	0 MR	24V DISC. SW. RLY GRD SIGNAL
D 6	SOUND SYSTEM-RR RH SPEAKER	S P 27	SPARE-RJB TO LH HAT RACK	0	CONDENSER CPT GRD	0 MS	24V DISC. SW. RLY GRD SIGNAL
D 7	SOUND SYSTEM-RR RH SPEAKER	S P 28	SPARE-RJB TO LH HAT RACK	0	RS - RR JCT BOX RLY GRD	0 N	RS - ENGINE CPT ACCES. GRD
D 8	SOUND SYSTEM-RR RH SPEAKER	S P 31	SPARE-RJB TO RH HAT RACK	0	GALLEY GRD	0 P	RS - ENGINE CPT ACCES. GRD
D 3 4	SOUND SYSTEM-RR RH SPEAKER	S P 32	SPARE-RJB TO RH HAT RACK	0 A	BC - SHIELD GRD	0 R	FS - SOUND SYS. JCT PANEL GRD
D 6 7	SOUND SYSTEM-RR RH SPEAKER	S P 33	SPARE-FJB TO RJB	0 A	RS - RR JCT BOX RLY GRD	0 R	RS - RJB GRD
G 1	SOUND SYSTEM-RR RH SPEAKER	S P 38	SPARE-FJB TO RJB	0 A	FRS - FR ROOF ACCES. GRD	0 R	RS - ENGINE CPT ACCES. GRD
G 2	SOUND SYSTEM-FR LH SPEAKER	S P 43	SPARE-FJB TO RJB	0 A	RS - LUG. CPT ACCES. GRD	0 RE	RADIO & CTRL HEAD CHASSIS GRD
G 3	SOUND SYSTEM-FR LH SPEAKER	S P 45	SPARE-FJB TO RJB	0 A A	RS - VOLTAGE REGULATOR GRD	0 RH	RS - RR END LAMPS RH GRD
G 4	SOUND SYSTEM-RR LH SPEAKER	S P 46	SPARE-RJB TO LH FR ROOF	0 B	EC - ENGINE GRD	0 S	12 VOLT RUN - GND RELAY
G 5	SOUND SYSTEM-RR LH SPEAKER	S P 48	SPARE-RJB TO DASH CENTER PANEL	0 B	FRS - FR ROOF HEAT WIND GRD	0 S2	SOUND SYSTEM RADIO GRD
G 6	SOUND SYSTEM-RR LH SPEAKER	S P 56	SPARE-ENGINE TO RH SW PANEL	0 B	RS - LUG. CPT ACCES. GRD	0 S3	SOUND SYSTEM VIDEO GRD
G 7	SOUND SYSTEM-RR LH SPEAKER	S P 57	SPARE-DASH CENTER PANEL TO ENG.	0 B E	RJB - BAT. EQUAL. BAT GRD	0 S S	SOUNDS SYSTEM BATT. GRD
G 8	SOUND SYSTEM-RR LH SPEAKER	S P 58	SPARE-DASH CENTER PANEL TO ENG.	0 C	EC - STARTER MOTOR GRD	0 T	FS - DASH ACCES. GRD
G 3 4	SOUND SYSTEM-RR LH SPEAKER	S P 59	SPARE-FJB TO ENGINE	0 C	FS - SERV. CPT ACCES. GRD	0 T1	FS - DASH ACCES. GRD
G 6 7	SOUND SYSTEM-RR LH SPEAKER	S P 61	SPARE-FJB TO DASH RH PANEL	0 C	BC - FAN CONDENSER GRD	0 T2	FS - DASH ACCES. GRD
L 1 A	INTERIOR LTS-110V FLUORESCENT	S P 68	SPARE-FJB TO ENGINE	0 C R	24V DISC. SW. RLY GRD SIGNAL	0 T3	FS - DASH ACCES. GRD
L 1 B	INTERIOR LTS-110V FLUORESCENT	S P 69	SPARE-FJB TO FR AXLE	0 C S	24V DISC. SW. RLY GRD SIGNAL	0 T4	FS - DASH ACCES. GRD
L 2 A	INTERIOR LTS-110V FLUORESCENT	S P 70	SPARE-FJB TO FR AXLE	0 C1	FS - SERV. CPT ACCES. GRD	0 V	RR JCT BOX CPT GRD STUD
L 2 B	INTERIOR LTS-110V FLUORESCENT	S P 71	SPARE-FJB TO RH SW PANEL	0 C2	FS - SERV. CPT ACCES. GRD	0 VA	BATTERY TO EQUALISER 0V
L 8	ENG. BLK & WATER TANK-HEATER	S P 72	SPARE-FJB TO FR SERV CPT	0 C3	FS - SERV. CPT ACCES. GRD	0 W	FS - WT GND & SHIELD
L 9	ENG. BLK & WATER TANK-HEATER	S P 74	SPARE-FJB TO LH CONSOLE	0 C4	FS - FJB CPT ACCES. GRD	0 W	RS - RR JCT BOX (WCL) GRD
L 0	110V RECEPTACLE- 110V FLUOR.	S P 77	SPARE-FJB TO EVAPORATOR CPT	0 D	BC - FAN CONDENSER GRD	0 W C	RS - RR JCT BOX GRD (WCL)
L 1	110V RECEPTACLE- 110V FLUOR.	S P 78	SPARE-FJB TO CONDENSER CPT	0 D	RS - HAT RACK ACCES. LH GRD	0 X	RS - RR JCT BOX GRD
L 2	110V RECEPTACLE- 110V FLUOR.	S P 79	SPARE-FJB TO CONDENSER CPT	0 D F	RS - RR SIDE FLASH & MARK GRD	0 Y	ABS FR JCT BOX CPT GRD STUD
R A	INTERIOR LTS-110V FLUORESCENT	S P 87	SPARE-RJB TO LH HAT RACK	0 D R	RS - RJB DOCKING LT RESISTORS	0 Y	RR JCT BOX GRD
R B	INTERIOR LTS-110V FLUORESCENT	S P 88	SPARE-RJB TO RH HAT RACK	0 E	RS - HAT RACK ACCES. LH GRD	0 Y1	ABS FR JCT BOX CPT GRD STUD
S H 1	SHIELD CHASSIS GRD	S P 92	SPARE-RJB TO CONDENSER CPT	0 F	RS - HAT RACK ACCES. RH GRD	0 Z	RR JCT BOX CPT GRD STUD
S H 2	SHIELD CHASSIS GRD	S P 93	SPARE-RJB TO EVAPORATOR CPT	0 G	RS - HAT RACK ACCES. RH GRD	0 0	FJB & RJB BATT. GRD
S H 3	SHIELD CHASSIS GRD	S P 94	SPARE-RJB TO RR ROOF	0 H	RS - LAVATORY ACCES. GRD	0 0 A	FBG - T.T.LT. MODULES BATT. GRD
S H 4	SHIELD CHASSIS GRD	S P 95	SPARE-RJB TO FR AXLE	0 J	FS - LH CONSOLE SW GRD	0 0 Y	FS - ABS MODULE BATT. GRD
S P 2	SPARE-FJB TO FR SERV CPT	S P 96	SPARE-RJB TO LUGG CPT #2	0 J	RS - RR ROOF ACCES. GRD	0 0 S S	SOUND SYSTEM BATT. GRD
S P 3	SPARE-FJB TO CENTER DASH	S P 97	SPARE-RJB TO LUGG CPT #3	0 K	RS - RR ROOF ACCES. GRD	1	TACHO SYSTEM - RPM SIGNAL +
S P 4	SPARE-FJB TO CENTER DASH	S P 98	SPARE-RJB TO LUGG CPT #3	0 K	RS - RJB A/C JCT PANEL GRD	2 A	A/C & HEAT SYSTEM-COOL 1 SIGN
S P 5	SPARE-RJB TO LUGG CPT #2	S P 104	SPARE-RJB TO ENGINE CPT	0 L	FS - FR SERVICE CPT LTS GRD	2 B	A/C & HEAT SYSTEM-COOL SIGN
S P 6	SPARE-RJB TO LUGG CPT #1	S P 105	SPARE-FJB TO ENGINE	0 L1	FS - FR SERVICE CPT LTS GRD	2 H	A/C & HEAT SYSTEM-HI PRESS SW
S P 7	SPARE-RJB TO LUGG CPT #1	S P 106	SPARE-RJB TO BATT. CPT.	0 L2	FS - FR SERVICE CPT LTS GRD	2 HL	A/C & HEAT SYSTEM-LO & HI PRESS SW
S P 8	SPARE-RJB TO LUGG CPT #1	S P 107	SPARE-RJB TO BATT. CPT.	0 L3	FS - FJB GRD	2 L	A/C & HEAT SYSTEM-LO PRESS SW
S P 9	SPARE-RJB TO LUGG CPT #2	S P 108	SPARE-RJB TO BATT. CPT.	0 L4	FS - FJB GRD	4	HOSTESS & PASSENGER CHIME
S P 10	SPARE-RJB TO LUGG CPT #1	S P 109	SPARE-RJB TO ENGINE CPT.	0 L5	FS - CIGAR LIGHTER	4 A	HOSTESS & PASSENGER CHIME
S P 11	SPARE-FJB TO RJB	S P 110	SPARE-RJB TO ENGINE CPT.	0 L	RS - ENGINE CPT ACCES. GRD	4 B	PASSENGER CHIME
S P 12	SPARE-RJB TO ENGINE	S P 111	SPARE-RJB TO ENGINE CPT.	0 L	ENTRANCE DOOR (SEDAN) GRD	4 C	HOSTESS CHIME
S P 13	SPARE-RJB TO ENGINE	S P 112	SPARE-RJB TO ENGINE CPT.	0 L H	RS - RR END LAMPS LH GRD	5	INTERIOR LTS-AISLE & EMERG. EXIT
S P 14	SPARE-FJB TO RJB	S P 114	SPARE-FJB TO U/DASH WIPER	0 M	FS - ELECTRICAL MOTOR GRD	5	UPPER WINDSHIELD DEFROSTER

# CIRCUIT NUMBER CODE

No.	DESCRIPTION	No.	DESCRIPTION	No.	DESCRIPTION	No.	DESCRIPTION
5 D	UPPER WINDSHIELD DEFROSTER	12 K	12 VOLT IGN. TTLT & HVAC MODULE	23 A	EXTERIOR LTS-DIRECTIONNAL RH	24 V5	RR JCT BOX 24V DISC SW
5 E	UPPER WINDSHIELD DEFROSTER	12 1A	12V IGNITION DISTRIBUTION	23 B	EXTERIOR LTS-DIRECTIONNAL RH	24 VD	24V HOT WIRE DISTRIBUTION
5 N	INTERIOR LTS-EMERGENCY EXIT	12 1A	FR JCT BOX 12V IGNITION	23 C	EXTERIOR LTS-CORNERING RH	24 VF	BAT CPT 24V SW TO FJB & IC
5 NC	SPEED SIGNAL LOWER 5MPH	12 1B	FR JCT BOX 12V IGNITION	23 N	EXTERIOR LTS-CORNERING RH	24 VA	BATTERY TO EQUALIZER 24V
5 NO	SPEED SIGNAL HIGHER 5MPH	12 1F	FR JCT BOX 12V IGNITION	23 P	EXTERIOR LTS-CORNERING RH	24 VI	RR JCT BOX 24V IGNITION
6	INTERIOR LTS-AISLE	12 LX	CLUSTER	24	BAT CPT 24V BATTERY	24 VR	BAT CPT 24V DISC SW TO RJB
7 B	ENTRANCE DOOR (SEDAN)	12 P	LH CONSOLE POWER OUTLET	24	FR JCT BOX 24V DISC SW	24 W	RR JCT BOX 24V DISC SW (WCL)
7 D	ENTRANCE DOOR (SEDAN)	12 R	BAT CPT 12V DISC RLY TO RJB	24 A	BOOSTER BLOCK 24V DISC SW	24 WC	BATT.CPT TO HYD. PUMP (WCL)
7 DA	ENTRANCE DOOR (SEDAN)	12 R	MEMORY BATTERY RADIO	24 A	FR JCT BOX 24V DISC SW	24 WL	24V BATTERY-HYD. PUMP (WCL)
9	INTERIOR LTS-ENGINE CPT	12 S	SOUND SYSTEM 12V RADIO	24 A	RR JCT BOX 24V DISC SW	25	12VAC GEN RLY ON SIGNAL
9 A	INTERIOR LTS-ENGINE CPT	12 S1	SOUND SYSTEM 12V RADIO	24 B	24V STARTER RLY FEEDING	25	12VAC GEN RLY ON SIGNAL
9 B	INTERIOR LTS-ENGINE CPT	12 S2	SOUND SYSTEM 12V RADIO	24 B	FR JCT BOX 24V DISC SW	25 A	NOT GENERATOR-WARNING LT
9 E	INTERIOR LTS-FR SERVICE CPT	12 SB	SOUND SYSTEM 12V FEEDING	24 B	RR JCT BOX 24V DISC SW	25 A	ETHER SWITCH
9 F	INTERIOR LTS-FR SERVICE CPT	12 SS	SOUND SYSTEM 12V FEEDING	24 BC	24 VOLT BATT. CHARGER	25 B	EXTERIOR LTS-DAYTIME RUN LTS
10	INTERIOR LTS-LUGGAGE CPT	12 VA	BATTERY TO EQUALIZER 12V	24 BE	RJB CPT-BAT EQ MONITOR HOT WIRE	25 F	12 VOLT IGN. DISTRIBUTION
10 A	INTERIOR LTS-LUGGAGE CPT	12 VD	12V HOT WIRE DISTRIBUTION	24 C	FR JCT BOX 24V DISC SW	26 A	CIGAR LIGHTER
10 B	INTERIOR LTS-LUGGAGE CPT	12 VF	BAT CPT 12V FJB & IC	24 C	RR JCT BOX 24V DISC SW	26	DRIVER'S WINDOW LIFTER
10 D	INTERIOR LTS-LUGGAGE CPT	12 VI	12V IGNITION DISTRIBUTION	24 D	BAT CPT 24V HOT WIRE	26 B	DRIVER'S WINDOW LIFTER
10 F	INTERIOR LTS-LUGGAGE CPT	12 VR	BAT CPT 12V DISC RLY TO RJB	24 D	FR JCT BOX 24V HOT WIRE	26 C	DRIVER'S WINDOW LIFTER
10 H	INTERIOR LTS-LUGGAGE CPT	12 W	12V BATTERY DDEC III	24 D	RR JCT BOX 24V HOT WIRE	27	LAVATORY-EMERGENCY SONALERT
10 K	INTERIOR LTS-LUGGAGE CPT	12 W	ENTRANCE DOOR (SEDAN)	24 DA	A/C JCT BOX 24V HOT WIRE	28 A	A/C & HEAT SYSTEM-HI PRESSURE
10 R	INTERIOR LTS-LUGGAGE DOOR AJAR	12 WA	ENTRANCE DOOR (SEDAN)	24 E	BAT CPT 24V DISC SW	29	A/C & HEAT SYSTEM-DRIVER'S HTR
11	FR DESTINATION SIGN	12 X	FR JCT BOX 12V DISC SW	24 E	FR JCT BOX 24V DISC SW	29 A	A/C & HEAT SYSTEM-DRIVER'S HTR
11 A	FR DESTINATION SIGN	12 X2	FR JCT BOX 12V DISC SW	24 E	RR JCT BOX 24V DISC SW	29 B	A/C & HEAT SYSTEM-DRIVER'S HTR
11 B	FR DESTINATION SIGN	12 Y	FR JCT BOX 12V DISC SW	24 F	FR JCT BOX 24V DISC SW	29 H	HVAC DASH MODULE
11 C	FR DESTINATION SIGN	13 A	ALARM & SIGNAL-LO AIR PRIM.	24 F	RR JCT BOX 24V DISC SW	30 A	GALLEY
11 D	FR DESTINATION SIGN	13 B	ALARM & SIGNAL-LO AIR SEC.	24 G	FR JCT BOX 24V DISC SW	31 A	A/C & HEAT SYSTEM-UNLOADER
11 E	FR DESTINATION SIGN	14	LAVATORY-FLUSHING PUMP	24 G	RR JCT BOX 24V DISC SW	31 B	A/C & HEAT SYSTEM-UNLOADER
11 K	FR DESTINATION SIGN	14 A	LAVATORY-FLUSHING PUMP	24 H	FR JCT BOX 24V DISC SW	31 B	WIPER & WASHER SYSTEM
12	12V BAT ELECTRONIC JCT BLOCK	15	EXTERIOR LTS-MULTI FUNC LEVEL	24 H	RR JCT BOX 24V DISC SW	31 C	WIPER & WASHER SYSTEM
12	BAT CPT 12V BATTERY	15 A	WIPER & WASHER UPPER WINDSHIELD	24 I	FR JCT BOX 24V IGNITION	31 D	WIPER & WASHER SYSTEM
12 A	FR JCT BOX 12V DISC SW	16	SPEED - SIGNAL +	24 I	RR JCT BOX 24V IGNITION	31 E	WIPER & WASHER SYSTEM
12 A	RR JCT BOX 12V DISC SW	16 A	SPEED - SIGNAL +	24 IA	FR JCT BOX 24V IGNITION	31 J	WIPER & WASHER SYSTEM
12 B	12V BAT ELECTRICAL JCT BLOCK	16 T	SPEED - SIGNAL +	24 IA	RR JCT BOX 24V IGNITION	31 X	WIPER & WASHER SYSTEM
12 B	RR JCT BOX 12V DISC SW	17	EXTERIOR LTS-FLASHER UNIT	24 IB	FR JCT BOX 24V IGNITION	32	EXTERIOR LTS-BACK-UP
12 B	FR JCT BOX 12V DISC SW	17 A	EXTERIOR LTS-FLASHER UNIT	24 IB	RR JCT BOX 24V IGNITION	32 B	EXTERIOR LTS-BACK-UP
12 BE	BAT. EQUALIZER MONITOR	19	DIFFERENTIAL OIL TEMP	24 IC	FR JCT BOX 24V IGNITION	32 C	BACK-UP PWR & SIGNAL
12 C	FR JCT BOX 12V DISC SW	20	SPEED - SIGNAL -	24 IF	FJB 24VOLT IGNITION	32 D	BACK-UP ALARM
12 C	RR JCT BOX 12V DISC SW	20 T	SPEED - SIGNAL -	24 P	FR JCT BOX 24V DISC SW	35	ENTRANCE DOOR (SEDAN)
12 D	BAT CPT 12V BATTERY	20 W	SPEED - SIGNAL -	24 S	24V DISC SW RLY SIGNAL	35 B	ENTRANCE DOOR (SEDAN)
12 DT	TTLT MODULE	21	EXTERIOR LTS-DIRECTIONNAL LH	24 S1	SOUND SYSTEM 24V AMPLIFIER	35 BB	ENTRANCE DOOR (SEDAN)
12 E	FR JCT BOX 12V DISC SW	21 A	EXTERIOR LTS-DIRECTIONNAL LH	24 S2	SOUND SYSTEM 24V AMPLIFIER	35 D	ENTRANCE DOOR (SEDAN)
12 E	RR JCT BOX 12V DISC SW	21 B	EXTERIOR LTS-HAZARD	24 S3	SOUND SYSTEM 24V VIDEO	36	JACOB BRAKE SYSEM
12 F	BAT CPT 12V FJB & IC	21 C	EXTERIOR LTS-CORNERING LH	24 S4	SOUND SYSTEM 24V VIDEO	36 A	JACOB BRAKE SYSEM
12 F	FR JCT BOX 12V DISC SW	21 H	EXTERIOR LTS-DIRECTIONNAL LH	24 SB	SOUND SYSTEM 24V FEEDING	38	INTERIOR LTS-24V FLUORESCENT
12 F	RR JCT BOX 12V DISC SW	21 K	EXTERIOR LTS-CORNERING	24 SS	SOUND SYSTEM 24V FEEDING	38 A	INTERIOR LTS-24V FLUORESCENT
12 G	FR JCT BOX 12V DISC SW	21 N	EXTERIOR LTS-CORNERING LH	24 T	RR JCT BOX 24V DISC SW	38 C	INTERIOR LTS-24V FLUORESCENT
12 J	FR JCT BOX 12V DISC SW	21 P	EXTERIOR LTS-CORNERING LH	24 V2	RR JCT BOX 24V DISC SW	38 D	INTERIOR LTS-24V FLUORESCENT
12 I	12V IGNITION DISTRIBUTION	23	EXTERIOR LTS-DIRECTIONNAL RH	24 V3	RR JCT BOX 24V DISC SW	39	INTERIOR LTS-24V LH CONSOLE SW
12 I	RR JCT BOX 12V IGNITION	23	EXTERIOR LTS-DIRECTIONNAL RH	24 V4	RR JCT BOX 24V DISC SW	39 A	INTERIOR LTS-DRIVER'S LTS

# CIRCUIT NUMBER CODE

No.	DESCRIPTION	No.	DESCRIPTION	No.	DESCRIPTION	No.	DESCRIPTION
39 P	READING LIGHTS	59 A	JACOB BRAKE SYSTEM	77 A	A/C & HEAT SYSTEM-DRIVER'S HTR	104	WORLD TRANSM-SOL. FORWARD
41	A/C & HEAT SYSTEM-COND FAN MOT	61	EXTERIOR LTS-24V FEED SW	77 B	A/C & HEAT SYSTEM-COMPRESSOR	105	WORLD TRANSM-RETARDER & SUMP
41 A	A/C & HEAT SYSTEM-COND FAN MOT	61 A	EXTERIOR LTS-HEAD SIGNAL	77 C	A/C & HEAT SYSTEM-COMPRESSOR	105 W	WORLD TRANSM-RETARDER & SUMP
41 B	A/C & HEAT SYSTEM-COND FAN MOT	62	LAVATORY-OCCUPIED LT	77 H	A/C & HEAT SYSTEM-COMPRESSOR	106	WORLD TRANSM-OIL LEVEL HI
42	A/C & HEAT SYSTEM-COND FAN MOT	62 A	LAVATORY-FLUOR LT	81	EXTERIOR LTS-STOP SW	107	CHARG SYST-VOLTAGE REGUL. "F"
42 A	A/C & HEAT SYSTEM-COND FAN MOT	62 B	LAVATORY-FLUOR LT	82	EXTERIOR LTS-STOP SIGNAL	107	WORLD TRANSM-LOCKUP SOL. HI
43	A/C & HEAT SYSTEM-COND FAN MOT	62 E	LAVATORY-OCCUP & FLUOR LT	82 A	EXTERIOR LTS-STOP SIGNAL	108	WORLD TRANSM-REM. PWR WAKE UP
44	EXTERIOR LTS-FOG	63	EXTERIOR LTS-CLEARANCE	82 B	EXTERIOR LTS-STOP LTS	109	WORLD TRANSM-RET. SOL. LO
44 A	EXTERIOR LTS-FOG	63 A	EXTERIOR LTS-CLEARANCE	82 K	EXTERIOR LTS-STOP PARK BRK	110	ALARM & SIGNAL-WATER TEMP
44 B	EXTERIOR LTS-FOG	63 B	EXTERIOR LTS-CLEARANCE	82 L	EXTERIOR LTS-LH STOP	110	WORLD TRANSM-LOCKUP SOL. LO
44 C	EXTERIOR LTS-FOG & HAZARD	63 C	EXTERIOR LTS-MARKER SIGNAL	82 R	EXTERIOR LTS-LH STOP	111	WORLD TRANSM-SOL. C6
45 B	A/C & HEAT SYSTEM-HEAT SIGN	63 D	EXTERIOR LTS-MARKER & TAIL	83	ENGINE CTR-KEY SW ACCES SIGN	112	WORLD TRANSM-SPARE OUTPUT (+)
45 D	A/C & HEAT SYSTEM-WATER VALVE	63 E	EXTERIOR LTS-CLEARANCE	84	ENGINE CTR-KEY SW ACCES SIGN	113	ALARM & SIGNAL-OIL PRESS
45 E	A/C & HEAT SYSTEM-HEAT 1 SIGN	63 F	EXTERIOR LTS-MARKER BLINKER	85	ENGINE CTR-KEY SWIGNITION SIGN	113	WORLD TRANSM-REVERSE WARNING
45 G	A/C & HEAT SYSTEM-DRIVER'S HTR	63 H	EXTERIOR LTS-TAIL	85	24V IGNITION SIGNAL	114	INTERIOR LTS-DASH LT REGUL.
45 H	A/C & HEAT SYSTEM-DRIVER'S HTR	64	DRIVERS FAN	85 A	24V IGN DASH INSTRUMENTATION	114	WORLD TRANSM-SPARE OUTPUT (-)
45 W	A/C & HEAT SYSTEM-COND. DOOR AJAR	64 B	DRIVERS FAN	85 B	ENGINE CTR-24V IGNITION	114 A	INTERIOR LTS-DASH LT
46	EXTERIOR LTS-MARKER	64 C	DRIVERS FAN	85 C	PARKING BRAKE SWITCH	114 B	INTERIOR LTS-DASH LT REGUL.
46 A	EXTERIOR LTS-MARKER	65	FOOT DAMPER MOTOR	85 F	ENGINE CTR-ENGINE CTR SW IGN	114 D	INTERIOR LTS-DASH LT REGUL.
46 B	EXTERIOR LTS-MARKER	65 A	FOOT DAMPER MOTOR	85 F	LO AIR SONALERT	114 E	INTERIOR LTS-DASH LT REGUL.
46 B	EXTERIOR LTS-MARKER	65 P	PASSENGER REC. DAMPER	85 W	24V IGN ANTI SKID	115	ALARM & SIGNAL-TAG PRESS
46 C	EXTERIOR LTS-MARKER	65 D	DRIVER REC. DAMPER	85 X	24V IGN ANTI SKID	115	DDEC III-COOLANT LEVEL
47	A/C & HEAT SYSTEM-DRIVER'S HTR	66	O_PASS. ON/OFF	85 Y	ANTI SKID-WARNING LT	115	WORLD TRANSM-DO NOT SHIFT SIGN
48	ENTRANCE DOOR (SEDAN)	67	24 VOLT RUN DISTRIBUTION	86	ENGINE CTR-STARTER SOL SIGN	115 C	DDEC III-COOLANT LEVEL
48 A	ENTRANCE DOOR (SEDAN)	67 A	A/C & HEAT SYSTEM	86 A	ENGINE CTR-STARTER SOL SIGN	115 W	WORLD TRANSM-DO NOT SHIFT SIGN
49	ENTRANCE DOOR (SEDAN)	67 B	A/C & HEAT SYSTEM	88	ENGINE CTR-RR START SIGNAL	116	WORLD TRANSM-LO SIGNAL SOL. HI
49 A	ENTRANCE DOOR (SEDAN)	67 C	HEATING WINDSHIELD	89	ENGINE CTR-RR START SIGNAL	116 B	A/C & HEAT SYSTEM-DRIVER'S HTR
50	AIR DRYER	67 K	A/C & HEAT SYSTEM-COND FAN CTR	90 B	A/C & HEAT SYSTEM-COND FAN MOT	117	WORLD TRANSM-SPARE INPUT (-)
52	ALARM & SIGNAL-ELEC. HORN	67 L	A/C & HEAT SYSTEM-COND FAN CTR	90 B	ENGINE CTR-MAST KEY SW FEED	117 A	ALARM & SIGNAL-TRANSM OIL TEMP
52 A	ALARM & SIGNAL-ELEC. HORN	67 V	A/C & HEAT SYSTEM-WATER VALVE	90 C	A/C & HEAT SYSTEM-COND FAN MOT	117 A	ALARM & SIGNAL-TRANSM OIL TEMP
52 B	ALARM & SIGNAL- AIR HORN	68	DASH & DEFROST DAMPER MOTOR	90 F	CHARG SYST-VOLTAGE REGUL. "B"	118	WORLD TRANSM-SPARE INPUT (+)
52 C	ALARM & SIGNAL- AIR HORN	68 A	DASH & DEFROST DAMPER MOTOR	90 H	A/C & HEAT SYSTEM-EVAP FAN MOT	119	WORLD TRANSM-ENG BRK INPUT (+)
53	ALARM & SIGNAL-ELEC. HORN	70	INTERIOR LTS-HAT RACK & RR RUN.	90 J	A/C & HEAT SYSTEM-COND FAN MOT	120	WORLD TRANSM-SOL. C1
53 A	WIPER & WASHER SYSTEM	72	SUN VISOR-FEEDING	91	PARKING BRAKE SW SIGNAL	121	WORLD TRANSM-SOL. GRD 2
53 B	WIPER & WASHER SYSTEM	72 A	SUN VISOR-RH	91 A	DDEC-FAST IDLE SIGNAL	122	A/C & HEAT SYSTEM-DRIVER'S HTR
53 C	WIPER & WASHER SYSTEM	72 B	SUN VISOR-RH	91 S	SONALERT PARKING BRAKE	122	A/C & HEAT SYSTEM-FRESH AIR
53 E	WIPER & WASHER SYSTEM	72 C	SUN VISOR-LH	91 W	PARK, BRAKE SW SIGN (WCL)	122	WORLD TRANSM-SOL. GRD 4
53 J	WIPER & WASHER SYSTEM	72 D	SUN VISOR-LH	92	BATTERY EQUALIZER-CHECK BALANCE	122 A	A/C & HEAT SYSTEM-FRESH AIR
55	EXTERIOR LTS-HI BEAM	73	LAVATORY-FEEDING	93	BATTERY EQUALIZER-CHECK LO/HI	123	WORLD TRANSM-NEUTRAL START
57	EXTERIOR LTS-HI BEAM	74	INTERIOR LTS-READING RH	95 A	ENGINE BRAKE & RETARDER SYSTEM	123 A	ALARM & SIGNAL-FIRE DETECTOR
57 A	A/C & HEAT SYSTEM-WATER PUMP	74 A	INTERIOR LTS-READING RH	97	TACHOMETER (-)	123 B	ALARM & SIGNAL-FIRE DETECTOR
57 A	EXTERIOR LTS-HI BEAM	74 D	INTERIOR LTS-READING SIGNAL	100	INTERIOR LTS-GENERAL	124	WORLD TRANSM-THROTTLE (HI)
57 B	A/C & HEAT SYSTEM-WATER PUMP	75	INTERIOR LTS-READING LH	100 A	INTERIOR LTS-GENERAL	125	WORLD TRANSM-RET. INDICATOR
57 C	PRE-HEAT WATER HEATER	75 A	INTERIOR LTS-READING LH	100 B	INTERIOR LTS-GENERAL	125	GALLEY LAMP
57 CA	A/C & HEAT SYSTEM-HEAT SIGN	76	FUEL TANK GAUGE	101	24V STARTER SOL FEEDING	125 T	GALLEY LAMP
57 CC	A/C & HEAT SYSTEM-HEAT SIGN	76 B	LOW FUEL LT & ETHER COLD START	101	WORLD TRANSM-LO SIGN SOL. LO	125 W	WORLD TRANSM-RET. INDICATOR
58	EXTERIOR LTS-LO BEAM	76 C	LOW FUEL LT	102	24V STARTER TO GENERATOR	126	KNEELING SYSTEM
58 A	EXTERIOR LTS-LO BEAM	76 P	FUEL PRIME PUMP	102	WORLD TRANSM-SOL. GRD 1	126 A	KNEELING SYSTEM
58 B	EXTERIOR LTS-LO BEAM	76 M	FUEL PRIME PUMP	102	WORLD TRANSM-SOL. C3	126 B	KNEELING SYSTEM
58 E	EXTERIOR LTS-LO BEAM	77	A/C & HEAT SYSTEM-HI PRESSURE	103	LOW BUOY	126 C	KNEELING SYSTEM

# CIRCUIT NUMBER CODE

No.	DESCRIPTION	No.	DESCRIPTION	No.	DESCRIPTION	No.	DESCRIPTION
126 D	KNEELING SYSTEM	137 A	MIRROR (SPARTAN & RAMCO)	154	ABS SYSTEM	214	WORLD TRANSM-BACK UP SIGNAL
126 E	KNEELING SYSTEM	137 B	RR VIEW MIRROR (SPARTAN)	154	WORLD TRANSM-ABS RET. INPUT	225	LAVATORY FAN
126 F	KNEELING SYSTEM	137 C	RR VIEW MIRROR (SPARTAN)	155	ABS SYSTEM	225 A	LAVATORY FAN
126 G	KNEELING SYSTEM	137 D	RR VIEW MIRROR (SPARTAN)	155	WORLD TRANSM-SPARE INPUT (-)	231	NEUTRAL SIGNAL GRD
126 H	KNEELING SYSTEM	137 E	RR VIEW MIRROR (SPARTAN)	156	ABS SYSTEM	231 A	NEUTRAL COIL RELAY FEED SIGNAL
126 K	KNEELING SYSTEM	137 G	RR VIEW MIRROR (SPARTAN)	156	WORLD TRANSM-THROTTLE POS.	231 W	NEUTRAL SIGNAL GRD (WCL)
126 P	KNEELING SYSTEM	138	ABS SYSTEM	156 A	ABS SYSTEM	240	DDEC III-ECM 12V FEEDING
126 R	KNEELING SYSTEM	138	WORLD TRANSM-RETARDER TEMP	157	ABS SYSTEM	241	DDEC III-ECM 12V FEEDING
126 W	5 MPH N.C. SIGNAL (WCL)	138 A	ABS SYSTEM	157	WORLD TRANSM-SPEEDO SIGNAL	251 A	DDEC III - DATA LOGGER 12 H.W.
126 S	KNEELING SYSTEM	139	ABS SYSTEM	157 A	ABS SYSTEM	251	DDEC III - PRODRIVER 12V H.W.
126 T	KNEELING SYSTEM	139	WORLD TRANSM-OUTPUT SPEED HI	157 B	ABS SYSTEM	253	GALLEY-MICROWAVE
127	WORLD TRANSM-LUBE PRESS SW.	140	ABS SYSTEM	158	WORLD TRANSM-DIMMER	254	GALLEY-12V FRIGO NORCOLD
127	PRE-HEAT WATER HEATER	140	WORLD TRANSM-OUTPUT SPEED LO	160	ALARM & SIGNAL-TAG PRESS SW	254 A	GALLEY-FRIGO
127 A	PRE-HEAT WATER HEATER	141	ABS SYSTEM	160	WORLD TRANSM-SER. INTERFACE (-)	255	GALLEY-COFEEMAKER
127 B	PRE-HEAT WATER HEATER	141	WORLD TRANSM-ENGINE SPEED HI	161	WORLD TRANSM-SIGNAL GRD	255 A	GALLEY-COFEEMAKER
127	WORLD TRANSM-RETARDER FEED SOL.	142	ABS SYSTEM	161 B	WORLD TRANSM-SIGNAL GRD	257	WINDSHIELD HEATED
127 S	PRE-HEAT WATER HEATER	142	WORLD TRANSM-SERIAL COM. A	162	WORLD TRANSM-PRESS. SW C3	257 A	WINDSHIELD HEATED
127 W	PRE-HEAT WATER HEATER	143	ABS SYSTEM	163	WORLD TRANSM-RETARDER ENABLE	257 B	WINDSHIELD HEATED
128	PRE-HEAT WATER HEATER	143	WORLD TRANSM-ECU BATTERY GRD	164	WORLD TRANSM-RET. ACTUATOR SIGN	257 C	WINDSHIELD HEATED
128 A	PRE-HEAT WATER HEATER	143 A	ABS SYSTEM	165	A/C & HEAT SYSTEM-TRANSMITER	257 D	WINDSHIELD HEATED SPARE
128 B	PRE-HEAT WATER HEATER	143 W	WORLD TRANSM-BATTERY GRD	165	WORLD TRANSM-OIL LEVEL SIGNAL	257 E	WINDSHIELD HEATED SPARE
128 W	PRE-HEAT WATER HEATER	143 X	WORLD TRANSM-BATTERY GRD	165 A	A/C & HEAT SYSTEM-TRANSMITER	258	WINDSHIELD HEATED
128	WORLD TRANSM-SOL. C2	144	ABS SYSTEM	165 B	A/C & HEAT SYSTEM-TRANSMITER	258 A	WINDSHIELD HEATED
129	PRE-HEAT WATER HEATER	144	WORLD TRANSM-ECU CHASSIS GRD	165 C	A/C & HEAT SYSTEM-TRANSMITER	259	WINDSHIELD HEATED
129	WORLD TRANSM-SOL. C5	144 A	ABS SYSTEM	165 D	A/C & HEAT SYSTEM-TRANSMITER	259 A	WINDSHIELD HEATED
130	WORLD TRANSM-SOL. GRD 3	145	ABS SYSTEM	166 B	A/C & HEAT SYSTEM-EVAP. MOD.	260	WINDOW AJAR
131	WORLD TRANSM-SOL. C4	146	ABS SYSTEM	167	A/C & HEAT SYSTEM-TEMP. CTR	290	FAN CLUTCH RADIATOR
132	WORLD TRANSM-ENG BRK OUTPUT (-)	146	WORLD TRANSM-IGNITION SENSE	167 A	A/C & HEAT SYSTEM-TEMP. CTR	290	FAN CLUTCH RADIATOR
132 W	WORLD TRANSM-ENG BRK OUTPUT (-)	146 W	WORLD TRANSM-12V IGNITION	168	A/C & HEAT SYSTEM-HUMIDISTAT	291	FAN CLUTCH RADIATOR SPD 1
133	GALLEY-HEAT CONTAINERS	146 X	WORLD TRANSM-12V IGNITION	168	WORLD TRANSM-SER. INTERFACE (+)	292	FAN CLUTCH RADIATOR SPD 2
133 A	GALLEY-HEAT CONTAINERS	147	ABS SYSTEM	168 A	A/C & HEAT SYSTEM-HUMIDISTAT	300	DOOR AJAR MAGN.SW. (WCL)
133 B	GALLEY-HEAT CONTAINERS	147	ETHER COLD START	170	LUGGAGE DOOR LOCK	300 A	POWER SYSTEM SW. (WCL)
133 C	GALLEY-HEAT CONTAINERS	147	WORLD TRANSM-OIL TEMP	170 C	LUGGAGE DOOR LOCK	300 B	DOOR AJAR ALARM (WCL)
133	WORLD TRANSM-RET. ACTUATOR HI	147 C	ETHER COLD START	170 E	LUGGAGE DOOR LOCK	301	POWER SYSTEM SW. (WCL)
134	GALLEY-HEAT CONTAINERS	148	ABS SYSTEM	170 H	LUGGAGE DOOR LOCK	302	DOOR AJAR T.T.LT. (WCL)
134 A	GALLEY-HEAT CONTAINERS	148	WORLD TRANSM-OUTPUT SPEED LO	181 A	THERMOMETER INSIDE SENSOR	302 A	DOOR AJAR ALARM SIGN.(WCL)
134	WORLD TRANSM-RET. APPLY SOL. HI	149	ABS SYSTEM	181 B	THERMOMETER INSIDE SENSOR	302 B	DOOR AJAR MAGN.SW. (WCL)
135	A/C & HEAT SYSTEM-AIR SENSOR	149	WORLD TRANSM-TURBINE SPEED HI	181 C	THERMOMETER OUTSIDE SENSOR	303	REMOTE WALL SW. DWN (WCL)
135 A	A/C & HEAT SYSTEM-AIR SENSOR	149 A	ABS SYSTEM	181 D	THERMOMETER OUTSIDE SENSOR	304	REMOTE WALL SW. UP (WCL)
135 D	A/C & HEAT SYSTEM-AIR SENSOR	150	DDEC III-ECM BATTERY GRD	197	FUEL WATER FILTER	305	PARK. BRAKE SOL. VALVE (WCL)
135 C	A/C & HEAT SYSTEM-AIR SENSOR	150	WORLD TRANSM-ENGINE SPEED LO	197 A	FUEL WATER FILTER	305 A	PARK. BRAKE SAFETY SW. (WCL)
135	WORLD TRANSM-ANALOG GRD	150 A	DDEC III-ECM BATTERY GRD	197 B	FUEL WATER FILTER	306	CONTROL SYSTEM (WCL RICON)
135 D	WORLD TRANSM-RETARDER RES MOD	151	ABS SYSTEM	198	FILTER FUEL HEATER	307	CONTROL SYSTEM (WCL RICON)
135 C	WORLD TRANSM-RETARDER TEMP	151	DDEC III-ECM BATTERY GRD	199	AIR FILTER RESTRICTION SENDER	308	CONTROL SYSTEM (WCL RICON)
136	GALLEY-ACCESSORIES	151	WORLD TRANSM-SERIAL COM. B	201	WORLD TRANSM-SPARE	309	CONTROL SYSTEM (WCL RICON)
136	WORLD TRANSM-ECU POWER	151 A	ABS SYSTEM	202	WORLD TRANSM-SPARE	417	DDEC III-LIMIT SPEED GOVERNOR
136 V	WORLD TRANSM-12V BATTERY	152	ABS SYSTEM	203	WORLD TRANSM-SPARE	419	DDEC III-CHECK ENGINE LIGHT
136 W	WORLD TRANSM-12V BATTERY	152 A	ABS SYSTEM	204	WORLD TRANSM-SPARE	439	DDEC III-12V IGNITION
136 X	WORLD TRANSM-12V BATTERY	153	ABS SYSTEM	205	WORLD TRANSM-SPARE	440	DDEC III-12V IGNITION
137	WORLD TRANSM-RETARDER	153	WORLD TRANSM-SPARE INPUT (-)	206	WORLD TRANSM-SPARE	440 A	DDEC III-12V IGNITION

## CIRCUIT NUMBER CODE

No.	DESCRIPTION	No.	DESCRIPTION	No.	DESCRIPTION	No.	DESCRIPTION
4 5 1	DDEC III-A/C FAN CLUTCH						
5 0 5	DDEC III-TACHOMETER DRIVE						
5 0 9	DDEC III-STOP ENGINE LIGHT						
5 1 0	DDEC III-FAST IDLE SIGNAL						
5 2 4	DDEC III-ENGINE BRAKE DISABLE						
5 2 5	DDEC III-FAST IDLE SIGNAL						
5 2 8	DDEC III-STOP ENG. OVERRIDE						
5 3 1	DDEC III-CRUISE CLUTCH RELEASE						
5 4 0	DDEC III-CRUISE ENABLE LTS.						
5 4 1	DDEC III-CRUISE SET SW						
5 4 3	DDEC III-CRUISE STOP SW CUT IN						
5 4 4	DDEC III-CRUISE ON/OFF SW						
5 4 5	DDEC III-CRUISE RESUME SW						
5 5 5	DDEC III-FAN CLUTCH SPEED# 1						
5 5 6	DDEC III-VEHICLE SPEED (+)						
5 5 7	DDEC III-VEHICLE SPEED (-)						
5 6 3	DDEC III-FAN CLUTCH SPEED# 2						
5 6 4	DDEC III-DIGITAL OUTPUT						
5 6 5	DDEC III-ENGINE BRAKE ACTIVE						
5 8 3	DDEC III-ENGINE BRAKE 4 CYL.						
9 0 0	DDEC III-DATA LINK (+)						
9 0 1	DDEC III-DATA LINK (-)						
9 0 8	DDEC III-HYDRAULIC PWM#1 OUTPUT						
9 1 6	DDEC III-SENSOR SUPPLY (5VDC)						
9 5 2	DDEC III-SENSOR RETURN						
9 5 3	DDEC III-BATTERY GRD						
9 7 9	DDEC III-ENGINE BRAKE 2 CYL.						



# CIRCUIT NUMBER CODE

No.	DESCRIPTION	No.	DESCRIPTION	No.	DESCRIPTION	No.	DESCRIPTION
B A	INTERIOR LTS-110V FLUORESCENT	S P 15	SPARE-RJB TO ENGINE	S P 115	SPARE-FJB TO U/DASH WIPER	0 M	FS - ELECTRICAL MOTOR GRD
B B	INTERIOR LTS-110V FLUORESCENT	S P 16	SPARE-RJB TO ENGINE	S P 116	SPARE-FJB TO U/DASH FLOOR	0 M3	FS - ELECTRICAL MOTOR GRD
D 1	SOUND SYSTEM-FR RH SPEAKER	S P 17	SPARE-RJB TO ENGINE	S P 117	SPARE-FJB TO U/DASH FLOOR	0 M4	FS - ELECTRICAL MOTOR GRD
D 2	SOUND SYSTEM-FR RH SPEAKER	S P 18	SPARE-FJB TO RJB	W C	A/C & HEAT SYST-EVAP CTR SIGN	0 M5	FS - ELECTRICAL MOTOR GRD
D 3	SOUND SYSTEM-RR RH SPEAKER	S P 24	SPARE-RJB TO LAVATORY ROOF	Y C	INTERIOR LTS-110V FLUORESCENT	0 M6	FS - FJB GRD
D 4	SOUND SYSTEM-RR RH SPEAKER	S P 25	SPARE-RJB TO LAVATORY ROOF	Y D	INTERIOR LTS-110V FLUORESCENT	0 M7	FS - ELECTRICAL MOTOR GRD
D 5	SOUND SYSTEM-RR RH SPEAKER	S P 26	SPARE-RJB TO LAVATORY ROOF	0	BC - BAT. CPT CHASSIS GRD	0 M	RS - ENGINE CPT ACCES. GRD
D 6	SOUND SYSTEM-RR RH SPEAKER	S P 27	SPARE-RJB TO LH HAT RACK	0	CONDENSER CPT GRD	0 MR	24V DISC. SW. RLY GRD SIGNAL
D 7	SOUND SYSTEM-RR RH SPEAKER	S P 28	SPARE-RJB TO LH HAT RACK	0	RS - RR JCT BOX RLY GRD	0 MS	24V DISC. SW. RLY GRD SIGNAL
D 8	SOUND SYSTEM-RR RH SPEAKER	S P 31	SPARE-RJB TO RH HAT RACK	0	GALLEY GRD	0 N	RS - ENGINE CPT ACCES. GRD
D 3 4	SOUND SYSTEM-RR RH SPEAKER	S P 32	SPARE-RJB TO RH HAT RACK	0 A	BC - SHIELD GRD	0 P	RS - ENGINE CPT ACCES. GRD
D 6 7	SOUND SYSTEM-RR RH SPEAKER	S P 33	SPARE-FJB TO RJB	0 A	RS - RR JCT BOX RLY GRD	0 R	FS - SOUND SYS. JCT PANEL GRD
G 1	SOUND SYSTEM-RR RH SPEAKER	S P 38	SPARE-FJB TO RJB	0 A	FRS - FR ROOF ACCES. GRD	0 R	RS - RJB GRD
G 2	SOUND SYSTEM-FR LH SPEAKER	S P 43	SPARE-FJB TO RJB	0 A	RS - LUG. CPT ACCES. GRD	0 R	RS - ENGINE CPT ACCES. GRD
G 3	SOUND SYSTEM-FR LH SPEAKER	S P 45	SPARE-FJB TO RJB	0 A A	RS - VOLTAGE REGULATOR GRD	0 R E	RADIO & CTRL HEAD CHASSIS GRD
G 4	SOUND SYSTEM-RR LH SPEAKER	S P 46	SPARE-RJB TO LH FR ROOF	0 B	EC - ENGINE GRD	0 R H	RS - RR END LAMPS RH GRD
G 5	SOUND SYSTEM-RR LH SPEAKER	S P 48	SPARE-RJB TO DASH CENTER PANEL	0 B	FRS - FR ROOF HEAT WIND GRD	0 S	12 VOLT RUN - GND RELAY
G 6	SOUND SYSTEM-RR LH SPEAKER	S P 56	SPARE-ENGINE TO RH SW PANEL	0 B	RS - LUG. CPT ACCES. GRD	0 S 2	SOUND SYSTEM RADIO GRD
G 7	SOUND SYSTEM-RR LH SPEAKER	S P 57	SPARE-DASH CENTER PANEL TO ENG.	0 B E	RJB - BAT. EQUAL. BAT GRD	0 S 3	SOUND SYSTEM VIDEO GRD
G 8	SOUND SYSTEM-RR LH SPEAKER	S P 58	SPARE-DASH CENTER PANEL TO ENG.	0 C	EC - STARTER MOTOR GRD	0 S S	SOUNDS SYSTEM BATT. GRD
G 3 4	SOUND SYSTEM-RR LH SPEAKER	S P 59	SPARE-FJB TO ENGINE	0 C	FS - SERV. CPT ACCES. GRD	0 T	FS - DASH ACCES. GRD
G 6 7	SOUND SYSTEM-RR LH SPEAKER	S P 61	SPARE-FJB TO DASH RH PANEL	0 C	BC - FAN CONDENSER GRD	0 T 1	FS - DASH ACCES. GRD
L 1 A	INTERIOR LTS-110V FLUORESCENT	S P 68	SPARE-FJB TO ENGINE	0 C R	24V DISC. SW. RLY GRD SIGNAL	0 T 2	FS - DASH ACCES. GRD
L 1 B	INTERIOR LTS-110V FLUORESCENT	S P 69	SPARE-FJB TO FR AXLE	0 C S	24V DISC. SW. RLY GRD SIGNAL	0 T 3	FS - DASH ACCES. GRD
L 2 A	INTERIOR LTS-110V FLUORESCENT	S P 70	SPARE-FJB TO FR AXLE	0 C 1	FS - SERV. CPT ACCES. GRD	0 T 4	FS - DASH ACCES. GRD
L 2 B	INTERIOR LTS-110V FLUORESCENT	S P 71	SPARE-FJB TO RH SW PANEL	0 C 2	FS - SERV. CPT ACCES. GRD	0 V	RR JCT BOX CPT GRD STUD
L 8	ENG. BLK & WATER TANK-HEATER	S P 72	SPARE-FJB TO FR SERV CPT	0 C 3	FS - SERV. CPT ACCES. GRD	0 V A	BATTERY TO EQUALISER 0V
L 9	ENG. BLK & WATER TANK-HEATER	S P 74	SPARE-FJB TO LH CONSOLE	0 C 4	FS - FJB CPT ACCES. GRD	0 W	FS - WT GND & SHIELD
L 0	110V RECEPTACLE- 110V FLUOR.	S P 77	SPARE-FJB TO EVAPORATOR CPT	0 D	BC - FAN CONDENSER GRD	0 W	RS - RR JCT BOX (WCL) GRD
L 1	110V RECEPTACLE- 110V FLUOR.	S P 78	SPARE-FJB TO CONDENSER CPT	0 D	RS - HAT RACK ACCES. LH GRD	0 W C	RS - RR JCT BOX GRD (WCL)
L 2	110V RECEPTACLE- 110V FLUOR.	S P 79	SPARE-FJB TO CONDENSER CPT	0 D F	RS - RR SIDE FLASH & MARK GRD	0 X	RS - RR JCT BOX GRD
R A	INTERIOR LTS-110V FLUORESCENT	S P 87	SPARE-RJB TO LH HAT RACK	0 D R	RS - RJB DOCKING LT RESISTORS	0 Y	ABS FR JCT BOX CPT GRD STUD
R B	INTERIOR LTS-110V FLUORESCENT	S P 88	SPARE-RJB TO RH HAT RACK	0 E	RS - HAT RACK ACCES. LH GRD	0 Y	RR JCT BOX GRD
S H 1	SHIELD CHASSIS GRD	S P 92	SPARE-RJB TO CONDENSER CPT	0 E A	EATON TRANSMISSION GRD	0 Y 1	ABS FR JCT BOX CPT GRD STUD
S H 2	SHIELD CHASSIS GRD	S P 93	SPARE-RJB TO EVAPORATOR CPT	0 F	RS - HAT RACK ACCES. RH GRD	0 Z	RR JCT BOX CPT GRD STUD
S H 3	SHIELD CHASSIS GRD	S P 94	SPARE-RJB TO RR ROOF	0 G	RS - HAT RACK ACCES. RH GRD	0 0	FJB & RJB BATT. GRD
S H 4	SHIELD CHASSIS GRD	S P 95	SPARE-RJB TO FR AXLE	0 H	RS - LAVATORY ACCES. GRD	0 0 A	FBG - T.T.LT. MODULES BATT. GRD
S P 2	SPARE-FJB TO FR SERV CPT	S P 96	SPARE-RJB TO LUGG CPT #2	0 J	FS - LH CONSOLE SW GRD	0 0 Y	FS - ABS MODULE BATT. GRD
S P 3	SPARE-FJB TO CENTER DASH	S P 97	SPARE-RJB TO LUGG CPT #3	0 J	RS - RR ROOF ACCES. GRD	0 0 S S	SOUND SYSTEM BATT. GRD
S P 4	SPARE-FJB TO CENTER DASH	S P 98	SPARE-RJB TO LUGG CPT #3	0 K	RS - RR ROOF ACCES. GRD	1	TACHO SYSTEM - RPM SIGNAL +
S P 5	SPARE-RJB TO LUGG CPT #2	S P 104	SPARE-RJB TO ENGINE CPT	0 K	RS - RJB A/C JCT PANEL GRD	2 A	A/C & HEAT SYSTEM-COOL 1 SIGN
S P 6	SPARE-RJB TO LUGG CPT #1	S P 105	SPARE-FJB TO ENGINE	0 L	FS - FR SERVICE CPT LTS GRD	2 B	A/C & HEAT SYSTEM-COOL SIGN
S P 7	SPARE-RJB TO LUGG CPT #1	S P 106	SPARE-RJB TO BATT. CPT.	0 L 1	FS - FR SERVICE CPT LTS GRD	2 B B	A/C & HEAT SYSTEM-COOL SIGN
S P 8	SPARE-RJB TO LUGG CPT #1	S P 107	SPARE-RJB TO BATT. CPT.	0 L 2	FS - FR SERVICE CPT LTS GRD	2 H	A/C & HEAT SYSTEM-HI PRESS SW
S P 9	SPARE-RJB TO LUGG CPT #2	S P 108	SPARE-RJB TO BATT. CPT.	0 L 3	FS - FJB GRD	2 H L	A/C & HEAT SYSTEM-LO & HI PRESS SW
S P 10	SPARE-RJB TO LUGG CPT #1	S P 109	SPARE-RJB TO ENGINE CPT.	0 L 4	FS - FJB GRD	2 L	A/C & HEAT SYSTEM-LO PRESS SW
S P 11	SPARE-FJB TO RJB	S P 110	SPARE-RJB TO ENGINE CPT.	0 L 5	FS - CIGAR LIGHTER	4	HOSTESS & PASSENGER CHIME
S P 12	SPARE-RJB TO ENGINE	S P 111	SPARE-RJB TO ENGINE CPT.	0 L	RS - ENGINE CPT ACCES. GRD	4 A	HOSTESS & PASSENGER CHIME
S P 13	SPARE-RJB TO ENGINE	S P 112	SPARE-RJB TO ENGINE CPT.	0 L	ENTRANCE DOOR (SEDAN) GRD	4 B	PASSENGER CHIME
S P 14	SPARE-FJB TO RJB	S P 114	SPARE-FJB TO U/DASH WIPER	0 L H	RS - RR END LAMPS LH GRD	4 C	HOSTESS CHIME

# CIRCUIT NUMBER CODE

No.	DESCRIPTION	No.	DESCRIPTION	No.	DESCRIPTION	No.	DESCRIPTION
5	INTERIOR LTS-AISLE & EMERG. EXIT	12 J	FR JCT BOX 12V DISC SW	21 P	EXTERIOR LTS-CORNERING LH	24 V2	RR JCT BOX 24V DISC SW
5	UPPER WINDSHIELD DEFROSTER	12 I	12V IGNITION DISTRIBUTION	23	EXTERIOR LTS-DIRECTIONAL RH	24 V3	RR JCT BOX 24V DISC SW
5 D	UPPER WINDSHIELD DEFROSTER	12 I	RR JCT BOX 12V IGNITION	23	EXTERIOR LTS-DIRECTIONAL RH	24 V4	RR JCT BOX 24V DISC SW
5 E	UPPER WINDSHIELD DEFROSTER	12 K	12 VOLT IGN. TTLT & HVAC MODULE	23 A	EXTERIOR LTS-DIRECTIONAL RH	24 V5	RR JCT BOX 24V DISC SW
5 N	INTERIOR LTS-EMERGENCY EXIT	12 IA	12V IGNITION DISTRIBUTION	23 B	EXTERIOR LTS-DIRECTIONAL RH	24 VD	24V HOT WIRE DISTRIBUTION
5 NC	SPEED SIGNAL LOWER 5MPH	12 IA	FR JCT BOX 12V IGNITION	23 C	EXTERIOR LTS-CORNERING RH	24 VF	BAT CPT 24V SW TO FJB & IC
5 NO	SPEED SIGNAL HIGHER 5MPH	12 IB	FR JCT BOX 12V IGNITION	23 N	EXTERIOR LTS-CORNERING RH	24 VA	BATTERY TO EQUALIZER 24V
6	INTERIOR LTS-AISLE	12 IF	FR JCT BOX 12V IGNITION	23 P	EXTERIOR LTS-CORNERING RH	24 VI	RR JCT BOX 24V IGNITION
7 B	ENTRANCE DOOR (SEDAN)	12 LX	CLUSTER (12V HOT WIRE)	24	BAT CPT 24V BATTERY	24 VR	BAT CPT 24V DISC SW TO RJB
7 D	ENTRANCE DOOR (SEDAN)	12 P	LH CONSOLE POWER OUTLET	24	FR JCT BOX 24V DISC SW	24 W	RR JCT BOX 24V DISC SW (WCL)
7 DA	ENTRANCE DOOR (SEDAN)	12 R	BAT CPT 12V DISC RLY TO RJB	24 A	BOOSTER BLOCK 24V DISC SW	24 WC	BATT.CPT TO HYD. PUMP (WCL)
9	INTERIOR LTS-ENGINE CPT	12 R	MEMORY BATTERY RADIO	24 A	FR JCT BOX 24V DISC SW	24 WL	24V BATTERY-HYD. PUMP (WCL)
9 A	INTERIOR LTS-ENGINE CPT	12 S	SOUND SYSTEM 12V RADIO	24 A	RR JCT BOX 24V DISC SW	25	12VAC GEN RLY ON SIGNAL
9 B	INTERIOR LTS-ENGINE CPT	12 S1	SOUND SYSTEM 12V RADIO	24 B	24V STARTER RLY FEEDING	25	12VAC GEN RLY ON SIGNAL
9 E	INTERIOR LTS-FR SERVICE CPT	12 S2	SOUND SYSTEM 12V RADIO	24 B	FR JCT BOX 24V DISC SW	25 A	NOT GENERATOR-WARNING LT
9 F	INTERIOR LTS-FR SERVICE CPT	12 SB	SOUND SYSTEM 12V FEEDING	24 B	RR JCT BOX 24V DISC SW	25 A	ETHER SWITCH
10	INTERIOR LTS-LUGGAGE CPT	12 SS	SOUND SYSTEM 12V FEEDING	24 BC	24 VOLT BATT. CHARGER	25 B	EXTERIOR LTS-DAYTIME RUN LTS
10 A	INTERIOR LTS-LUGGAGE CPT	12 VA	BATTERY TO EQUALIZER 12V	24 BE	RJB CPT-BAT EQ MONITOR HOT WIRE	25 F	12 VOLT IGN. DISTRIBUTION
10 B	INTERIOR LTS-LUGGAGE CPT	12 VD	12V HOT WIRE DISTRIBUTION	24 C	FR JCT BOX 24V DISC SW	26 A	CIGAR LIGHTER
10 D	INTERIOR LTS-LUGGAGE CPT	12 VF	BAT CPT 12V FJB & IC	24 C	RR JCT BOX 24V DISC SW	26	DRIVER'S WINDOW LIFTER
10 F	INTERIOR LTS-LUGGAGE CPT	12 VI	12V IGNITION DISTRIBUTION	24 D	BAT CPT 24V HOT WIRE	26 B	DRIVER'S WINDOW LIFTER
10 H	INTERIOR LTS-LUGGAGE CPT	12 VR	BAT CPT 12V DISC RLY TO RJB	24 D	FR JCT BOX 24V HOT WIRE	26 C	DRIVER'S WINDOW LIFTER
10 K	INTERIOR LTS-LUGGAGE CPT	12 W	12V BATTERY DDEC III	24 D	RR JCT BOX 24V HOT WIRE	27	LAVATORY-EMERGENCY SONALERT
10 R	INTERIOR LTS-LUGGAGE DOOR AJAR	12 W	ENTRANCE DOOR (SEDAN)	24 DA	A/C JCT BOX 24V HOT WIRE	28 A	A/C & HEAT SYSTEM-HI PRESSURE
11	FR DESTINATION SIGN	12 WA	ENTRANCE DOOR (SEDAN)	24 E	BAT CPT 24V DISC SW	29	A/C & HEAT SYSTEM-DRIVER'S HTR
11 A	FR DESTINATION SIGN	12 X	FR JCT BOX 12V DISC SW	24 E	FR JCT BOX 24V DISC SW	29 A	A/C & HEAT SYSTEM-DRIVER'S HTR
11 B	FR DESTINATION SIGN	12 X2	FR JCT BOX 12V DISC SW	24 E	RR JCT BOX 24V DISC SW	29 B	A/C & HEAT SYSTEM-DRIVER'S HTR
11 C	FR DESTINATION SIGN	12 Y	FR JCT BOX 12V DISC SW	24 F	FR JCT BOX 24V DISC SW	29 H	HVAC DASH MODULE
11 D	FR DESTINATION SIGN	13 A	ALARM & SIGNAL-LO AIR PRIM.	24 F	RR JCT BOX 24V DISC SW	30 A	GALLEY
11 E	FR DESTINATION SIGN	13 B	ALARM & SIGNAL-LO AIR SEC.	24 G	FR JCT BOX 24V DISC SW	31 A	A/C & HEAT SYSTEM-UNLOADER
11 K	FR DESTINATION SIGN	14	LAVATORY-FLUSHING PUMP	24 G	RR JCT BOX 24V DISC SW	31 B	A/C & HEAT SYSTEM-UNLOADER
12	12V BAT ELECTRONIC JCT BLOCK	14 A	LAVATORY-FLUSHING PUMP	24 H	FR JCT BOX 24V DISC SW	31 B	WIPER & WASHER SYSTEM
12	BAT CPT 12V BATTERY	15	EXTERIOR LTS-MULTI FUNC LEVEL	24 H	RR JCT BOX 24V DISC SW	31 C	WIPER & WASHER SYSTEM
12 A	FR JCT BOX 12V DISC SW	15 A	WIPER & WASHER UPPER WINDSHIELD	24 I	FR JCT BOX 24V IGNITION	31 D	WIPER & WASHER SYSTEM
12 A	RR JCT BOX 12V DISC SW	16	SPEED - SIGNAL +	24 I	RR JCT BOX 24V IGNITION	31 E	WIPER & WASHER SYSTEM
12 B	12V BAT ELECTRICAL JCT BLOCK	16 A	SPEED - SIGNAL +	24 IA	FR JCT BOX 24V IGNITION	31 J	WIPER & WASHER SYSTEM
12 B	RR JCT BOX 12V DISC SW	16 T	SPEED - SIGNAL +	24 IA	RR JCT BOX 24V IGNITION	31 X	WIPER & WASHER SYSTEM
12 B	FR JCT BOX 12V DISC SW	17	EXTERIOR LTS-FLASHER UNIT	24 IB	FR JCT BOX 24V IGNITION	32	EXTERIOR LTS-BACK-UP
12 BE	BAT. EQUALIZER MONITOR	17 A	EXTERIOR LTS-FLASHER UNIT	24 IB	RR JCT BOX 24V IGNITION	32 B	EXTERIOR LTS-BACK-UP
12 C	FR JCT BOX 12V DISC SW	19	DIFFERENTIAL OIL TEMP	24 IC	FR JCT BOX 24V IGNITION	32 C	BACK-UP PWR & SIGNAL
12 C	RR JCT BOX 12V HOT WIRE	20	SPEED - SIGNAL -	24 IF	FJB 24VOLT IGNITION	32 D	BACK-UP ALARM
12 CE	RR JCT BOX 12V HOT WIRE	20 T	SPEED - SIGNAL -	24 P	FR JCT BOX 24V DISC SW	35	ENTRANCE DOOR (SEDAN)
12 D	BAT CPT 12V BATTERY	20 W	SPEED - SIGNAL -	24 S	24V DISC SW RLY SIGNAL	35 B	ENTRANCE DOOR (SEDAN)
12 DT	TTLT MODULE	21	EXTERIOR LTS-DIRECTIONAL LH	24 S1	SOUND SYSTEM 24V AMPLIFIER	35 BB	ENTRANCE DOOR (SEDAN)
12 E	FR JCT BOX 12V DISC SW	21 A	EXTERIOR LTS-DIRECTIONAL LH	24 S2	SOUND SYSTEM 24V AMPLIFIER	35 D	ENTRANCE DOOR (SEDAN)
12 E	RR JCT BOX 12V DISC SW	21 B	EXTERIOR LTS-HAZARD	24 S3	SOUND SYSTEM 24V VIDEO	36	JACOB BRAKE SYSEM
12 F	BAT CPT 12V FJB & IC	21 C	EXTERIOR LTS-CORNERING LH	24 S4	SOUND SYSTEM 24V VIDEO	36 A	JACOB BRAKE SYSEM
12 F	FR JCT BOX 12V DISC SW	21 H	EXTERIOR LTS-DIRECTIONAL LH	24 SB	SOUND SYSTEM 24V FEEDING	38	INTERIOR LTS-24V FLUORESCENT
12 F	RR JCT BOX 12V DISC SW	21 K	EXTERIOR LTS-CORNERING	24 SS	SOUND SYSTEM 24V FEEDING	38 A	INTERIOR LTS-24V FLUORESCENT
12 G	FR JCT BOX 12V DISC SW	21 N	EXTERIOR LTS-CORNERING LH	24 T	RR JCT BOX 24V DISC SW	38 C	INTERIOR LTS-24V FLUORESCENT

# CIRCUIT NUMBER CODE

No.	DESCRIPTION	No.	DESCRIPTION	No.	DESCRIPTION	No.	DESCRIPTION
38 D	INTERIOR LTS-24V FLUORESCENT	58 A	EXTERIOR LTS-LO BEAM	76 P	FUEL PRIME PUMP	102	WORLD TRANSM-SOL. GRD 1
39	INTERIOR LTS-24V LH CONSOLE SW	58 B	EXTERIOR LTS-LO BEAM	76 M	FUEL PRIME PUMP	102	WORLD TRANSM-SOL. C3
39 A	INTERIOR LTS-DRIVER'S LTS	58 E	EXTERIOR LTS-LO BEAM	77	A/C & HEAT SYSTEM-HI PRESSURE	103	LOW BUOY
39 P	READING LIGHTS	59 A	JACOB BRAKE SYSTEM	77 A	A/C & HEAT SYSTEM-DRIVER'S HTR	104	WORLD TRANSM-SOL. FORWARD
41	A/C & HEAT SYSTEM-COND FAN MOT	61	EXTERIOR LTS-24V FEED SW	77 B	A/C & HEAT SYSTEM-COMPRESSOR	105	WORLD TRANSM-RETARDER & SUMP
41 A	A/C & HEAT SYSTEM-COND FAN MOT	61 A	EXTERIOR LTS-HEAD SIGNAL	77 C	A/C & HEAT SYSTEM-COMPRESSOR	105 W	WORLD TRANSM-RETARDER & SUMP
41 B	A/C & HEAT SYSTEM-COND FAN MOT	62	LAVATORY-OCCUPIED LT	77 H	A/C & HEAT SYSTEM-COMPRESSOR	106	WORLD TRANSM-OIL LEVEL HI
42	A/C & HEAT SYSTEM-COND FAN MOT	62 A	LAVATORY-FLUOR LT	81	EXTERIOR LTS-STOP SW	107	CHARG SYST-VOLTAGE REGUL. "F"
42 A	A/C & HEAT SYSTEM-COND FAN MOT	62 B	LAVATORY-FLUOR LT	82	EXTERIOR LTS-STOP SIGNAL	107	WORLD TRANSM-LOCKUP SOL. HI
43	A/C & HEAT SYSTEM-COND FAN MOT	62 E	LAVATORY-OCCUP & FLUOR LT	82 A	EXTERIOR LTS-STOP SIGNAL	108	WORLD TRANSM-REM. PWR WAKE UP
44	EXTERIOR LTS-FOG	63	EXTERIOR LTS-CLEARANCE	82 B	EXTERIOR LTS-STOP LTS	109	WORLD TRANSM-RET. SOL. LO
44 A	EXTERIOR LTS-FOG	63 A	EXTERIOR LTS-CLEARANCE	82 K	EXTERIOR LTS-STOP PARK BRK	110	ALARM & SIGNAL-WATER TEMP
44 B	EXTERIOR LTS-FOG	63 B	EXTERIOR LTS-CLEARANCE	82 L	EXTERIOR LTS-LH STOP	110	WORLD TRANSM-LOCKUP SOL. LO
44 C	EXTERIOR LTS-FOG & HAZARD	63 C	EXTERIOR LTS-MARKER SIGNAL	82 R	EXTERIOR LTS-LH STOP	111	WORLD TRANSM-SOL. C6
45 B	A/C & HEAT SYSTEM-HEAT SIGN	63 D	EXTERIOR LTS-MARKER & TAIL	83	ENGINE CTR-KEY SW ACCES SIGN	112	WORLD TRANSM-SPARE OUTPUT (+)
45 D	A/C & HEAT SYSTEM-WATER VALVE	63 E	EXTERIOR LTS-CLEARANCE	84	ENGINE CTR-KEY SW ACCES SIGN	113	ALARM & SIGNAL-OIL PRESS
45 E	A/C & HEAT SYSTEM-HEAT 1 SIGN	63 F	EXTERIOR LTS-MARKER BLINKER	85	ENGINE CTR-KEY SWIGNITION SIGN	113	WORLD TRANSM-REVERSE WARNING
45 G	A/C & HEAT SYSTEM-DRIVER'S HTR	63 H	EXTERIOR LTS-TAIL	85	24V IGNITION SIGNAL	114	INTERIOR LTS-DASH LT REGUL.
45 H	A/C & HEAT SYSTEM-DRIVER'S HTR	64	DRIVERS FAN	85 A	24V IGN DASH INSTRUMENTATION	114	WORLD TRANSM-SPARE OUTPUT (-)
45 W	A/C & HEAT SYSTEM-COND. DOOR AJAR	64 B	DRIVERS FAN	85 B	ENGINE CTR-24V IGNITION	114 A	INTERIOR LTS-DASH LT
46	EXTERIOR LTS-MARKER	64 C	DRIVERS FAN	85 C	PARKING BRAKE SWITCH	114 B	INTERIOR LTS-DASH LT REGUL.
46 A	EXTERIOR LTS-MARKER	65	FOOT DAMPER MOTOR	85 F	ENGINE CTR-ENGINE CTR SW IGN	114 D	INTERIOR LTS-DASH LT REGUL.
46 B	EXTERIOR LTS-MARKER	65 A	FOOT DAMPER MOTOR	85 F	LO AIR SONALERT	114 E	INTERIOR LTS-DASH LT REGUL.
46 B	EXTERIOR LTS-MARKER	65 P	PASSENGER REC. DAMPER	85 W	24V IGN ANTI SKID	115	ALARM & SIGNAL-TAG PRESS
46 C	EXTERIOR LTS-MARKER	65 D	DRIVER REC. DAMPER	85 X	24V IGN ANTI SKID	115	DDEC III-COOLANT LEVEL
47	A/C & HEAT SYSTEM-DRIVER'S HTR	66	O_PASS. ON/OFF	85 Y	ANTI SKID-WARNING LT	115	WORLD TRANSM-DO NOT SHIFT SIGN
48	ENTRANCE DOOR (SEDAN)	67	24 VOLT RUN DISTRIBUTION	86	ENGINE CTR-STARTER SOL SIGN	115 C	DDEC III-COOLANT LEVEL
48 A	ENTRANCE DOOR (SEDAN)	67 A	A/C & HEAT SYSTEM	86 A	ENGINE CTR-STARTER SOL SIGN	115 W	WORLD TRANSM-DO NOT SHIFT SIGN
49	ENTRANCE DOOR (SEDAN)	67 B	A/C & HEAT SYSTEM	88	ENGINE CTR-RR START SIGNAL	116	WORLD TRANSM-LO SIGNAL SOL. HI
49 A	ENTRANCE DOOR (SEDAN)	67 C	HEATING WINDSHIELD	89	ENGINE CTR-RR START SIGNAL	116 B	A/C & HEAT SYSTEM-DRIVER'S HTR
50	AIR DRYER	67 K	A/C & HEAT SYSTEM-COND FAN CTR	90 B	A/C & HEAT SYSTEM-COND FAN MOT	117	WORLD TRANSM-SPARE INPUT (-)
52	ALARM & SIGNAL-ELEC. HORN	67 L	A/C & HEAT SYSTEM-COND FAN CTR	90 B	ENGINE CTR-MAST KEY SW FEED	117 A	ALARM & SIGNAL-TRANSM OIL TEMP
52 A	ALARM & SIGNAL-ELEC. HORN	67 V	A/C & HEAT SYSTEM-WATER VALVE	90 C	A/C & HEAT SYSTEM-COND FAN MOT	117 A	ALARM & SIGNAL-TRANSM OIL TEMP
52 B	ALARM & SIGNAL- AIR HORN	68	DASH & DEFROST DAMPER MOTOR	90 F	CHARG SYST-VOLTAGE REGUL. "B"	118	WORLD TRANSM-SPARE INPUT (+)
52 C	ALARM & SIGNAL- AIR HORN	68 A	DASH & DEFROST DAMPER MOTOR	90 H	A/C & HEAT SYSTEM-EVAP FAN MOT	119	WORLD TRANSM-ENG BRK INPUT (+)
53	ALARM & SIGNAL-ELEC. HORN	70	INTERIOR LTS-HAT RACK & RR RUN.	90 J	A/C & HEAT SYSTEM-COND FAN MOT	120	WORLD TRANSM-SOL. C1
53 A	WIPER & WASHER SYSTEM	72	SUN VISOR-FEEDING	91	PARKING BRAKE SW SIGNAL	121	WORLD TRANSM-SOL. GRD 2
53 B	WIPER & WASHER SYSTEM	72 A	SUN VISOR-RH	91 A	DDEC-FAST IDLE SIGNAL	122	A/C & HEAT SYSTEM-DRIVER'S HTR
53 C	WIPER & WASHER SYSTEM	72 B	SUN VISOR-RH	91 S	SONALERT PARKING BRAKE	122	A/C & HEAT SYSTEM-FRESH AIR
53 E	WIPER & WASHER SYSTEM	72 C	SUN VISOR-LH	91 W	PARK, BRAKE SW SIGN (WCL)	122	WORLD TRANSM-SOL. GRD 4
53 J	WIPER & WASHER SYSTEM	72 D	SUN VISOR-LH	92	BATTERY EQUALIZER-CHECK BALANCE	122 A	A/C & HEAT SYSTEM-FRESH AIR
55	EXTERIOR LTS-HI BEAM	73	LAVATORY-FEEDING	93	BATTERY EQUALIZER-CHECK LO/HI	123	WORLD TRANSM-NEUTRAL START
57	EXTERIOR LTS-HI BEAM	74	INTERIOR LTS-READING RH	95 A	ENGINE BRAKE & RETARDER SYSTEM	123 A	ALARM & SIGNAL-FIRE DETECTOR
57 A	A/C & HEAT SYSTEM-WATER PUMP	74 A	INTERIOR LTS-READING RH	97	TACHOMETER (-)	123 B	ALARM & SIGNAL-FIRE DETECTOR
57 A	EXTERIOR LTS-HI BEAM	74 D	INTERIOR LTS-READING SIGNAL	100	INTERIOR LTS-GENERAL	124	WORLD TRANSM-THROTTLE (HI)
57 B	A/C & HEAT SYSTEM-WATER PUMP	75	INTERIOR LTS-READING LH	100 A	INTERIOR LTS-GENERAL	125	WORLD TRANSM-RET. INDICATOR
57 C	PRE-HEAT WATER HEATER	75 A	INTERIOR LTS-READING LH	100 B	INTERIOR LTS-GENERAL	125	GALLEY LAMP
57 CA	A/C & HEAT SYSTEM-HEAT SIGN	76	FUEL TANK GAUGE	101	24V STARTER SOL FEEDING	125 T	GALLEY LAMP
57 CC	A/C & HEAT SYSTEM-HEAT SIGN	76 B	LOW FUEL LT & ETHER COLD START	101	WORLD TRANSM-LO SIGN SOL. LO	125 W	WORLD TRANSM-RET. INDICATOR
58	EXTERIOR LTS-LO BEAM	76 C	LOW FUEL LT	102	24V STARTER TO GENERATOR	126	KNEELING SYSTEM

# CIRCUIT NUMBER CODE

No.	DESCRIPTION	No.	DESCRIPTION	No.	DESCRIPTION	No.	DESCRIPTION
126 A	KNEELING SYSTEM	136 W	WORLD TRANSM-12V BATTERY	152 A	ABS SYSTEM	202	WORLD TRANSM-SPARE
126 B	KNEELING SYSTEM	136 X	WORLD TRANSM-12V BATTERY	153	ABS SYSTEM	203	WORLD TRANSM-SPARE
126 C	KNEELING SYSTEM	137	WORLD TRANSM-RETARDER	153	WORLD TRANSM-SPARE INPUT (-)	204	WORLD TRANSM-SPARE
126 D	KNEELING SYSTEM	137 A	MIRROR (SPARTAN & RAMCO)	154	ABS SYSTEM	205	WORLD TRANSM-SPARE
126 E	KNEELING SYSTEM	137 B	RR VIEW MIRROR (SPARTAN)	154	WORLD TRANSM-ABS RET. INPUT	206	WORLD TRANSM-SPARE
126 F	KNEELING SYSTEM	137 C	RR VIEW MIRROR (SPARTAN)	155	ABS SYSTEM	214	WORLD TRANSM-BACK UP SIGNAL
126 G	KNEELING SYSTEM	137 D	RR VIEW MIRROR (SPARTAN)	155	WORLD TRANSM-SPARE INPUT (-)	225	LAVATORY FAN
126 H	KNEELING SYSTEM	137 E	RR VIEW MIRROR (SPARTAN)	156	ABS SYSTEM	225 A	LAVATORY FAN
126 K	KNEELING SYSTEM	137 G	RR VIEW MIRROR (SPARTAN)	156	WORLD TRANSM-THROTTLE POS.	231	NEUTRAL SIGNAL GRD
126 P	KNEELING SYSTEM	138	ABS SYSTEM	156 A	ABS SYSTEM	231 A	NEUTRAL COIL RELAY FEED SIGNAL
126 R	KNEELING SYSTEM	138	WORLD TRANSM-RETARDER TEMP	157	ABS SYSTEM	231 W	NEUTRAL SIGNAL GRD (WCL)
126 W	5 MPH N.C. SIGNAL (WCL)	138 A	ABS SYSTEM	157	WORLD TRANSM-SPEEDO SIGNAL	240	DDEC III-ECM 12V FEEDING
126 S	KNEELING SYSTEM	139	ABS SYSTEM	157 A	ABS SYSTEM	241	DDEC III-ECM 12V FEEDING
126 T	KNEELING SYSTEM	139	WORLD TRANSM-OUTPUT SPEED HI	157 B	ABS SYSTEM	251 A	DDEC III - DATA LOGGER 12 H.W.
127	WORLD TRANSM-LUBE PRESS SW.	140	ABS SYSTEM	157 D	A.T.C. SYSTEM	251	DDEC III - PRODRIVER 12V H.W.
127	PRE-HEAT WATER HEATER	140	WORLD TRANSM-OUTPUT SPEED LO	157 E	A.T.C. SYSTEM	253	GALLEY-MICROWAVE
127 A	PRE-HEAT WATER HEATER	141	ABS SYSTEM	158	WORLD TRANSM-DIMMER	254	GALLEY-12V FRIGO NORCOLD
127 B	PRE-HEAT WATER HEATER	141	WORLD TRANSM-ENGINE SPEED HI	160	ALARM & SIGNAL-TAG PRESS SW	254 A	GALLEY-FRIGO
127	WORLD TRANSM-RETARDER FEED SOL.	142	ABS SYSTEM	160	WORLD TRANSM-SER. INTERFACE (-)	255	GALLEY-COFEEMAKER
127 S	PRE-HEAT WATER HEATER	142	WORLD TRANSM-SERIAL COM. A	161	WORLD TRANSM-SIGNAL GRD	255 A	GALLEY-COFEEMAKER
127 W	PRE-HEAT WATER HEATER	143	ABS SYSTEM	161 B	WORLD TRANSM-SIGNAL GRD	257	WINDSHIELD HEATED
128	PRE-HEAT WATER HEATER	143	WORLD TRANSM-ECU BATTERY GRD	162	WORLD TRANSM-PRESS. SW C3	257 A	WINDSHIELD HEATED
128 A	PRE-HEAT WATER HEATER	143 A	ABS SYSTEM	163	WORLD TRANSM-RETARDER ENABLE	257 B	WINDSHIELD HEATED
128 B	PRE-HEAT WATER HEATER	143 W	WORLD TRANSM-BATTERY GRD	164	WORLD TRANSM-RET. ACTUATOR SIGN	257 C	WINDSHIELD HEATED
128 W	PRE-HEAT WATER HEATER	144	ABS SYSTEM	165	A/C & HEAT SYSTEM-TRANSMITER	257 D	WINDSHIELD HEATED SPARE
128	WORLD TRANSM-SOL. C2	144	WORLD TRANSM-ECU CHASSIS GRD	165	WORLD TRANSM-OIL LEVEL SIGNAL	257 E	WINDSHIELD HEATED SPARE
129	PRE-HEAT WATER HEATER	144 A	ABS SYSTEM	165 A	A/C & HEAT SYSTEM-TRANSMITER	258	WINDSHIELD HEATED
129	WORLD TRANSM-SOL. C5	145	ABS SYSTEM	165 B	A/C & HEAT SYSTEM-TRANSMITER	258 A	WINDSHIELD HEATED
130	WORLD TRANSM-SOL. GRD 3	146	ABS SYSTEM	165 C	A/C & HEAT SYSTEM-TRANSMITER	259	WINDSHIELD HEATED
131	WORLD TRANSM-SOL. C4	146 A	TRANSMISSION-12V IGNITION	165 D	A/C & HEAT SYSTEM-TRANSMITER	259 A	WINDSHIELD HEATED
132	WORLD TRANSM-ENG BRK OUTPUT (-)	146	WORLD TRANSM-IGNITION SENSE	166 B	A/C & HEAT SYSTEM-EVAP. MOD.	260	WINDOW AJAR
132 W	WORLD TRANSM-ENG BRK OUTPUT (-)	146 W	WORLD TRANSM-12V IGNITION	167	A/C & HEAT SYSTEM-TEMP. CTR	290	FAN CLUTCH RADIATOR
133	GALLEY-HEAT CONTAINERS	146 X	WORLD TRANSM-12V IGNITION	167 A	A/C & HEAT SYSTEM-TEMP. CTR	290	FAN CLUTCH RADIATOR
133 A	GALLEY-HEAT CONTAINERS	147	ABS SYSTEM	168	A/C & HEAT SYSTEM-HUMIDISTAT	291	FAN CLUTCH RADIATOR SPD 1
133 B	GALLEY-HEAT CONTAINERS	147	ETHER COLD START	168	WORLD TRANSM-SER. INTERFACE (+)	292	FAN CLUTCH RADIATOR SPD 2
133 C	GALLEY-HEAT CONTAINERS	147	WORLD TRANSM-OIL TEMP	168 A	A/C & HEAT SYSTEM-HUMIDISTAT	300	DOOR AJAR MAGN.SW. (WCL)
133	WORLD TRANSM-RET. ACTUATOR HI	147 C	ETHER COLD START	170	LUGGAGE DOOR LOCK	300 A	POWER SYSTEM SW. (WCL)
134	GALLEY-HEAT CONTAINERS	148	ABS SYSTEM	170 C	LUGGAGE DOOR LOCK	300 B	DOOR AJAR ALARM (WCL)
134 A	GALLEY-HEAT CONTAINERS	148	WORLD TRANSM-OUTPUT SPEED LO	170 E	LUGGAGE DOOR LOCK	301	POWER SYSTEM SW. (WCL)
134	WORLD TRANSM-RET. APPLY SOL. HI	149	ABS SYSTEM	170 H	LUGGAGE DOOR LOCK	302	DOOR AJAR T.T.LT. (WCL)
135	A/C & HEAT SYSTEM-AIR SENSOR	149	WORLD TRANSM-TURBINE SPEED HI	181 A	THERMOMETER INSIDE SENSOR	302 A	DOOR AJAR ALARM SIGN.(WCL)
135 A	A/C & HEAT SYSTEM-AIR SENSOR	149 A	ABS SYSTEM	181 B	THERMOMETER INSIDE SENSOR	302 B	DOOR AJAR MAGN.SW. (WCL)
135 D	A/C & HEAT SYSTEM-AIR SENSOR	150	DDEC III-ECM BATTERY GRD	181 C	THERMOMETER OUTSIDE SENSOR	303	REMOTE WALL SW. DWN (WCL)
135 C	A/C & HEAT SYSTEM-AIR SENSOR	150	WORLD TRANSM-ENGINE SPEED LO	181 D	THERMOMETER OUTSIDE SENSOR	304	REMOTE WALL SW. UP (WCL)
135	WORLD TRANSM-ANALOG GRD	150 A	DDEC III-ECM BATTERY GRD	197	FUEL WATER FILTER	305	PARK. BRAKE SOL. VALVE (WCL)
135 D	WORLD TRANSM-RETARDER RES MOD	151	ABS SYSTEM	197 A	FUEL WATER FILTER	305 A	PARK. BRAKE SAFETY SW. (WCL)
135 C	WORLD TRANSM-RETARDER TEMP	151	DDEC III-ECM BATTERY GRD	197 B	FUEL WATER FILTER	306	CONTROL SYSTEM (WCL RICON)
136	GALLEY-ACCESSORIES	151	WORLD TRANSM-SERIAL COM. B	198	FILTER FUEL HEATER	307	CONTROL SYSTEM (WCL RICON)
136	WORLD TRANSM-ECU POWER	151 A	ABS SYSTEM	199	AIR FILTER RESTRICTION SENDER	308	CONTROL SYSTEM (WCL RICON)
136 V	WORLD TRANSM-12V BATTERY	152	ABS SYSTEM	201	WORLD TRANSM-SPARE	309	CONTROL SYSTEM (WCL RICON)

## CIRCUIT NUMBER CODE

No.	DESCRIPTION	No.	DESCRIPTION	No.	DESCRIPTION	No.	DESCRIPTION
3 1 0	EATON TRANSMISSION	9 0 1	DDEC III-DATA LINK (-)				
3 1 1	EATON TRANSMISSION	9 0 8	DDEC III-HYDRAULIC PWM#1 OUTPUT				
3 1 2	EATON TRANSMISSION	9 1 6	DDEC III-SENSOR SUPPLY (5VDC)				
3 1 3	EATON TRANSMISSION	9 2 5	J1939-HIGH				
3 1 4	EATON TRANSMISSION	9 2 6	J1939-LOW				
3 1 5	EATON TRANSMISSIOM	9 2 7	J1939-SHIELD				
3 1 6	EATON TRANSMISSION - EPL	9 5 2	DDEC III-SENSOR RETURN				
3 1 7	EATON TRANSMISSION	9 5 3	DDEC III-BATTERY GRD				
3 1 8	EATON TRANSMISSION	9 7 9	DDEC III-ENGINE BRAKE 2 CYL.				
3 1 9	EATON TRANSMISSION						
3 2 0	EATON TRANSMISSION						
3 2 1	EATON TRANSMISSION						
3 2 2	EATON TRANSMISSIION						
3 2 3	EATON TRANSMISSION						
3 2 4	EATON TRANSMISSION						
3 2 5	EATON TRANSMISSION						
3 2 6	EATON TRANSMISSION						
3 2 7	EATON TRANSMISSION						
3 2 8	EATON TRANSMISSION						
3 2 9	EATON TRANSMISSION						
3 3 0	EATON TRANSMISSION - EPL						
3 3 1	EATON TRANSMISSION - EPL						
3 3 2	EATON TRANSMISSION						
3 3 3	EATON TRANSMISSION - 12V BATTERY						
4 1 7	DDEC III-LIMIT SPEED GOVERNOR						
4 1 9	DDEC III-CHECK ENGINE LIGHT						
4 3 9	DDEC III-12V IGNITION						
4 4 0	DDEC III-12V IGNITION						
4 4 0 A	DDEC III-12V IGNITION						
4 5 1	DDEC III-A/C FAN CLUTCH						
5 0 5	DDEC III-TACHOMETER DRIVE						
5 0 9	DDEC III-STOP ENGINE LIGHT						
5 1 0	DDEC III-FAST IDLE SIGNAL						
5 2 4	DDEC III-ENGINE BRAKE DISABLE						
5 2 5	DDEC III-FAST IDLE SIGNAL						
5 2 8	DDEC III-STOP ENG. OVERRIDE						
5 3 1	DDEC III-CRUISE CLUTCH RELEASE						
5 4 0	DDEC III-CRUISE ENABLE LTS.						
5 4 1	DDEC III-CRUISE SET SW						
5 4 3	DDEC III-CRUISE STOP SW CUT IN						
5 4 4	DDEC III-CRUISE ON/OFF SW						
5 4 5	DDEC III-CRUISE RESUME SW						
5 5 5	DDEC III-FAN CLUTCH SPEED# 1						
5 5 6	DDEC III-VEHICLE SPEED (+)						
5 5 7	DDEC III-VEHICLE SPEED (-)						
5 6 3	DDEC III-FAN CLUTCH SPEED# 2						
5 6 4	DDEC III-DIGITAL OUTPUT						
5 6 5	DDEC III-ENGINE BRAKE ACTIVE						
5 8 3	DDEC III-ENGINE BRAKE 4 CYL.						
9 0 0	DDEC III-DATA LINK (+)						

# CIRCUIT NUMBER CODE

No.	DESCRIPTION	No.	DESCRIPTION	No.	DESCRIPTION	No.	DESCRIPTION
BA	INTERIOR LTS-110V FLUORESCENT	SP 15	SPARE-RJB TO ENGINE	SP 115	SPARE-FJB TO U/DASH WIPER	0 M	FS - ELECTRICAL MOTOR GRD
BB	INTERIOR LTS-110V FLUORESCENT	SP 16	SPARE-RJB TO ENGINE	SP 116	SPARE-FJB TO U/DASH FLOOR	0 M3	FS - ELECTRICAL MOTOR GRD
D 1	SOUND SYSTEM-FR RH SPEAKER	SP 17	SPARE-RJB TO ENGINE	SP 117	SPARE-FJB TO U/DASH FLOOR	0 M4	FS - ELECTRICAL MOTOR GRD
D 2	SOUND SYSTEM-FR RH SPEAKER	SP 18	SPARE-FJB TO RJB	W C	A/C & HEAT SYST-EVAP CTR SIGN	0 M5	FS - ELECTRICAL MOTOR GRD
D 3	SOUND SYSTEM-RR RH SPEAKER	SP 24	SPARE-RJB TO LAVATORY ROOF	Y C	INTERIOR LTS-110V FLUORESCENT	0 M6	FS - FJB GRD
D 4	SOUND SYSTEM-RR RH SPEAKER	SP 25	SPARE-RJB TO LAVATORY ROOF	Y D	INTERIOR LTS-110V FLUORESCENT	0 M7	FS - ELECTRICAL MOTOR GRD
D 5	SOUND SYSTEM-RR RH SPEAKER	SP 26	SPARE-RJB TO LAVATORY ROOF	0	BC - BAT. CPT CHASSIS GRD	0 M	RS - ENGINE CPT ACCES. GRD
D 6	SOUND SYSTEM-RR RH SPEAKER	SP 27	SPARE-RJB TO LH HAT RACK	0	CONDENSER CPT GRD	0 MR	24V DISC. SW. RLY GRD SIGNAL
D 7	SOUND SYSTEM-RR RH SPEAKER	SP 28	SPARE-RJB TO LH HAT RACK	0	RS - RR JCT BOX RLY GRD	0 MS	24V DISC. SW. RLY GRD SIGNAL
D 8	SOUND SYSTEM-RR RH SPEAKER	SP 31	SPARE-RJB TO RH HAT RACK	0	GALLEY GRD	0 N	RS - ENGINE CPT ACCES. GRD
D 3 4	SOUND SYSTEM-RR RH SPEAKER	SP 32	SPARE-RJB TO RH HAT RACK	0 A	BC - SHIELD GRD	0 P	RS - ENGINE CPT ACCES. GRD
D 6 7	SOUND SYSTEM-RR RH SPEAKER	SP 33	SPARE-FJB TO RJB	0 A	RS - RR JCT BOX RLY GRD	0 R	FS - SOUND SYS. JCT PANEL GRD
G 1	SOUND SYSTEM-RR RH SPEAKER	SP 38	SPARE-FJB TO RJB	0 A	FRS - FR ROOF ACCES. GRD	0 R	RS - FJB GRD
G 2	SOUND SYSTEM-FR LH SPEAKER	SP 43	SPARE-FJB TO RJB	0 A	RS - LUG. CPT ACCES. GRD	0 R	RS - ENGINE CPT ACCES. GRD
G 3	SOUND SYSTEM-FR LH SPEAKER	SP 45	SPARE-FJB TO RJB	0 A A	RS - VOLTAGE REGULATOR GRD	0 R E	RADIO & CTRL HEAD CHASSIS GRD
G 4	SOUND SYSTEM-RR LH SPEAKER	SP 46	SPARE-RJB TO LH FR ROOF	0 B	EC - ENGINE GRD	0 R H	RS - RR END LAMPS RH GRD
G 5	SOUND SYSTEM-RR LH SPEAKER	SP 48	SPARE-RJB TO DASH CENTER PANEL	0 B	FRS - FR ROOF HEAT WIND GRD	0 S	12 VOLT RUN - GND RELAY
G 6	SOUND SYSTEM-RR LH SPEAKER	SP 56	SPARE-ENGINE TO RH SW PANEL	0 B	RS - LUG. CPT ACCES. GRD	0 S A	EC-BOSCH ALT. GROUND
G 7	SOUND SYSTEM-RR LH SPEAKER	SP 57	SPARE-DASH CENTER PANEL TO ENG.	0 B E	RJB - BAT. EQUAL. BAT GRD	0 S 2	SOUND SYSTEM RADIO GRD
G 8	SOUND SYSTEM-RR LH SPEAKER	SP 58	SPARE-DASH CENTER PANEL TO ENG.	0 C	EC - STARTER MOTOR GRD	0 S 3	SOUND SYSTEM VIDEO GRD
G 3 4	SOUND SYSTEM-RR LH SPEAKER	SP 59	SPARE-FJB TO ENGINE	0 C	FS - SERV. CPT ACCES. GRD	0 S S	SOUNDS SYSTEM BATT. GRD
G 6 7	SOUND SYSTEM-RR LH SPEAKER	SP 61	SPARE-FJB TO DASH RH PANEL	0 C	BC - FAN CONDENSER GRD	0 T	FS - DASH ACCES. GRD
L 1 A	INTERIOR LTS-110V FLUORESCENT	SP 68	SPARE-FJB TO ENGINE	0 C R	24V DISC. SW. RLY GRD SIGNAL	0 T 1	FS - DASH ACCES. GRD
L 1 B	INTERIOR LTS-110V FLUORESCENT	SP 69	SPARE-FJB TO FR AXLE	0 C S	24V DISC. SW. RLY GRD SIGNAL	0 T 2	FS - DASH ACCES. GRD
L 2 A	INTERIOR LTS-110V FLUORESCENT	SP 70	SPARE-FJB TO FR AXLE	0 C 1	FS - SERV. CPT ACCES. GRD	0 T 3	FS - DASH ACCES. GRD
L 2 B	INTERIOR LTS-110V FLUORESCENT	SP 71	SPARE-FJB TO RH SW PANEL	0 C 2	FS - SERV. CPT ACCES. GRD	0 T 4	FS - DASH ACCES. GRD
L 8	ENG. BLK & WATER TANK-HEATER	SP 72	SPARE-FJB TO FR SERV CPT	0 C 3	FS - SERV. CPT ACCES. GRD	0 V	RR JCT BOX CPT GRD STUD
L 9	ENG. BLK & WATER TANK-HEATER	SP 7 4	SPARE-FJB TO LH CONSOLE	0 C 4	FS - FJB CPT ACCES. GRD	0 V A	BATTERY TO EQUALISER 0V
L 0	110V RECEPTACLE- 110V FLUOR.	SP 77	SPARE-FJB TO EVAPORATOR CPT	0 D	BC - FAN CONDENSER GRD	0 W	FS - WT GND & SHIELD
L 1	110V RECEPTACLE- 110V FLUOR.	SP 7 8	SPARE-FJB TO CONDENSER CPT	0 D	RS - HAT RACK ACCES. LH GRD	0 W	RS - RR JCT BOX (WCL) GRD
L 2	110V RECEPTACLE- 110V FLUOR.	SP 7 9	SPARE-FJB TO CONDENSER CPT	0 D F	RS - RR SIDE FLASH & MARK GRD	0 W C	RS - RR JCT BOX GRD (WCL)
RA	INTERIOR LTS-110V FLUORESCENT	SP 8 7	SPARE-RJB TO LH HAT RACK	0 D R	RS - RJB DOCKING LT RESISTORS	0 X	RS - RR JCT BOX GRD
RB	INTERIOR LTS-110V FLUORESCENT	SP 8 8	SPARE-RJB TO RH HAT RACK	0 E	RS - HAT RACK ACCES. LH GRD	0 Y	ABS FR JCT BOX CPT GRD STUD
SH 1	SHIELD CHASSIS GRD	SP 9 2	SPARE-RJB TO CONDENSER CPT	0 E A	EATON TRANSMISSION GRD	0 Y	RR JCT BOX GRD
SH 2	SHIELD CHASSIS GRD	SP 9 3	SPARE-RJB TO EVAPORATOR CPT	0 F	RS - HAT RACK ACCES. RH GRD	0 Y 1	ABS FR JCT BOX CPT GRD STUD
SH 3	SHIELD CHASSIS GRD	SP 9 4	SPARE-RJB TO RR ROOF	0 G	RS - HAT RACK ACCES. RH GRD	0 Z	RR JCT BOX CPT GRD STUD
SH 4	SHIELD CHASSIS GRD	SP 9 5	SPARE-RJB TO RR ROOF	0 H	RS - LAVATORY ACCES. GRD	0 0	FJB & RJB BATT. GRD
SP 2	SPARE-FJB TO FR SERV CPT	SP 9 6	SPARE-RJB TO LUGG CPT #2	0 J	FS - LH CONSOLE SW GRD	0 0 A	FBG - T.T.LT. MODULES BATT. GRD
SP 3	SPARE-FJB TO CENTER DASH	SP 9 7	SPARE-RJB TO LUGG CPT #3	0 J	RS - RR ROOF ACCES. GRD	0 0 Y	FS - ABS MODULLE BATT. GRD
SP 4	SPARE-FJB TO CENTER DASH	SP 9 8	SPARE-RJB TO LUGG CPT #3	0 K	RS - RR ROOF ACCES. GRD	0 0 S S	SOUND SYSTEM BATT. GRD
SP 5	SPARE-RJB TO LUGG CPT #2	SP 1 0 4	SPARE-RJB TO ENGINE CPT	0 K	RS - RJB A/C JCT PANEL GRD	1	TACHO SYSTEM - RPM SIGNAL +
SP 6	SPARE-RJB TO LUGG CPT #1	SP 1 0 5	SPARE-FJB TO ENGINE	0 L	FS - FR SERVICE CPT LTS GRD	2 A	A/C & HEAT SYSTEM-COOL 1 SIGN
SP 7	SPARE-RJB TO LUGG CPT #1	SP 1 0 6	SPARE-RJB TO BATT. CPT.	0 L 1	FS - FR SERVICE CPT LTS GRD	2 B	A/C & HEAT SYSTEM-COOL SIGN
SP 8	SPARE-RJB TO LUGG CPT #1	SP 1 0 7	SPARE-RJB TO BATT. CPT.	0 L 2	FS - FR SERVICE CPT LTS GRD	2 B B	A/C & HEAT SYSTEM-COOL SIGN
SP 9	SPARE-RJB TO LUGG CPT #2	SP 1 0 8	SPARE-RJB TO BATT. CPT.	0 L 3	FS - FJB GRD	2 H	A/C & HEAT SYSTEM-HI PRESS SW
SP 1 0	SPARE-RJB TO LUGG CPT #1	SP 1 0 9	SPARE-RJB TO ENGINE CPT.	0 L 4	FS - FJB GRD	2 H L	A/C & HEAT SYSTEM-LO & HI PRESS SW
SP 1 1	SPARE-FJB TO RJB	SP 1 1 0	SPARE-RJB TO ENGINE CPT.	0 L 5	FS - CIGAR LIGHTER	2 L	A/C & HEAT SYSTEM-LO PRESS SW
SP 1 2	SPARE-RJB TO ENGINE	SP 1 1 1	SPARE-RJB TO ENGINE CPT.	0 L	RS - ENGINE CPT ACCES. GRD	4	HOSTESS & PASSENGER CHIME
SP 1 3	SPARE-RJB TO ENGINE	SP 1 1 2	SPARE-RJB TO ENGINE CPT.	0 L	ENTRANCE DOOR (SEDAN) GRD	4 A	HOSTESS & PASSENGER CHIME
SP 1 4	SPARE-FJB TO RJB	SP 1 1 4	SPARE-FJB TO U/DASH WIPER	0 L H	RS - RR END LAMPS LH GRD	4 B	PASSENGER CHIME



# CIRCUIT NUMBER CODE

No.	DESCRIPTION	No.	DESCRIPTION	No.	DESCRIPTION	No.	DESCRIPTION
4 C	HOSTESS CHIME	12 G	FR JCT BOX 12V DISC SW	21 K	EXTERIOR LTS-CORNERING	24 SS	SOUND SYSTEM 24V FEEDING
5	INTERIOR LTS-AISLE & EMERG. EXIT	12 H	12 V IGNITION D.T.RUN LIGHT	21 N	EXTERIOR LTS-CORNERING LH	24 T	RR JCT BOX 24V DISC SW
5	UPPER WINDSHIELD DEFROSTER	12 J	FR JCT BOX 12V DISC SW	21 P	EXTERIOR LTS-CORNERING LH	24 V2	RR JCT BOX 24V DISC SW
5 D	UPPER WINDSHIELD DEFROSTER	12 I	12V IGNITION DISTRIBUTION	23	EXTERIOR LTS-DIRECTIONNAL RH	24 V3	RR JCT BOX 24V DISC SW
5 E	UPPER WINDSHIELD DEFROSTER	12 I	RR JCT BOX 12V IGNITION	23	EXTERIOR LTS-DIRECTIONNAL RH	24 V4	RR JCT BOX 24V DISC SW
5 N	INTERIOR LTS-EMERGENCY EXIT	12 K	12 VOLT IGN. TTLT & HVAC MODULE	23 A	EXTERIOR LTS-DIRECTIONNAL RH	24 V5	RR JCT BOX 24V DISC SW
5 NC	SPEED SIGNAL LOWER 5MPH	12 IA	12V IGNITION DISTRIBUTION	23 B	EXTERIOR LTS-DIRECTIONNAL RH	24 VD	24V HOT WIRE DISTRIBUTION
5 NO	SPEED SIGNAL HIGHER 5MPH	12 IA	FR JCT BOX 12V IGNITION	23 C	EXTERIOR LTS-CORNERING RH	24 VF	BAT CPT 24V SW TO FJB & IC
6	INTERIOR LTS-AISLE	12 IB	FR JCT BOX 12V IGNITION	23 N	EXTERIOR LTS-CORNERING RH	24 VA	BATTERY TO EQUALIZER 24V
7 B	ENTRANCE DOOR (SEDAN)	12 IF	FR JCT BOX 12V IGNITION	23 P	EXTERIOR LTS-CORNERING RH	24 VI	RR JCT BOX 24V IGNITION
7 D	ENTRANCE DOOR (SEDAN)	12 LX	CLUSTER (12V HOT WIRE)	24	BAT CPT 24V BATTERY	24 VR	BAT CPT 24V DISC SW TO RJB
7 DA	ENTRANCE DOOR (SEDAN)	12 P	LH CONSOLE POWER OUTLET	24	FR JCT BOX 24V DISC SW	24 W	RR JCT BOX 24V DISC SW (WCL)
9	INTERIOR LTS-ENGINE CPT	12 R	BAT CPT 12V DISC RLY TO RJB	24 A	BOOSTER BLOCK 24V DISC SW	24 WC	BATT.CPT TO HYD. PUMP (WCL)
9 A	INTERIOR LTS-ENGINE CPT	12 R	MEMORY BATTERY RADIO	24 A	FR JCT BOX 24V DISC SW	24 WL	24V BATTERY-HYD. PUMP (WCL)
9 B	INTERIOR LTS-ENGINE CPT	12 S	SOUND SYSTEM 12V RADIO	24 A	RR JCT BOX 24V DISC SW	25 A1	PRE-EXITATION ALT. BOSCH #1
9 E	INTERIOR LTS-FR SERVICE CPT	12 S1	SOUND SYSTEM 12V RADIO	24 B	24V STARTER RLY FEEDING	25 A2	PRE-EXITATION ALT. BOSCH #2
9 F	INTERIOR LTS-FR SERVICE CPT	12 S2	SOUND SYSTEM 12V RADIO	24 B	FR JCT BOX 24V DISC SW	25 A	T.T. LT. ALTERNATOR #1
10	INTERIOR LTS-LUGGAGE CPT	12 SB	SOUND SYSTEM 12V FEEDING	24 B	RR JCT BOX 24V DISC SW	25 B	12 VOLTS IGN. ALT. SIGNAL MODULE
10 A	INTERIOR LTS-LUGGAGE CPT	12 SS	SOUND SYSTEM 12V FEEDING	24 BC	24 VOLT BATT. CHARGER	25 D	12 V. ENGINE RUN / HVAC SYSTEM
10 B	INTERIOR LTS-LUGGAGE CPT	12 VA	BATTERY TO EQUALIZER 12V	24 BE	RJB CPT-BAT EQ MONITOR HOT WIRE	25 F	12 VOLT IGN. DISTRIBUTION
10 D	INTERIOR LTS-LUGGAGE CPT	12 VD	12V HOT WIRE DISTRIBUTION	24 C	FR JCT BOX 24V DISC SW	25 H	24 VOLT IGN. ALT. BOSCH
10 F	INTERIOR LTS-LUGGAGE CPT	12 VF	BAT CPT 12V FJB & IC	24 C	RR JCT BOX 24V DISC SW	25 K	T.T. LT. ALTERNATOR #2
10 H	INTERIOR LTS-LUGGAGE CPT	12 VI	12V IGNITION DISTRIBUTION	24 D	BAT CPT 24V HOT WIRE	26 A	CIGAR LIGHTER
10 K	INTERIOR LTS-LUGGAGE CPT	12 VR	BAT CPT 12V DISC RLY TO RJB	24 D	FR JCT BOX 24V HOT WIRE	26	DRIVER'S WINDOW LIFTER
10 R	INTERIOR LTS-LUGGAGE DOOR AJAR	12 W	12V BATTERY DDEC III	24 D	RR JCT BOX 24V HOT WIRE	26 B	DRIVER'S WINDOW LIFTER
11	FR DESTINATION SIGN	12 W	ENTRANCE DOOR (SEDAN)	24 DA	A/C JCT BOX 24V HOT WIRE	26 C	DRIVER'S WINDOW LIFTER
11 A	FR DESTINATION SIGN	12 WA	ENTRANCE DOOR (SEDAN)	24 E	BAT CPT 24V DISC SW	27	LAVATORY-EMERGENCY SONALERT
11 B	FR DESTINATION SIGN	12 X	FR JCT BOX 12V DISC SW	24 E	FR JCT BOX 24V DISC SW	28 A	A/C & HEAT SYSTEM-HI PRESSURE
11 C	FR DESTINATION SIGN	12 X2	FR JCT BOX 12V DISC SW	24 E	RR JCT BOX 24V DISC SW	29	A/C & HEAT SYSTEM-DRIVER'S HTR
11 D	FR DESTINATION SIGN	12 Y	FR JCT BOX 12V DISC SW	24 F	FR JCT BOX 24V DISC SW	29 A	A/C & HEAT SYSTEM-DRIVER'S HTR
11 E	FR DESTINATION SIGN	13 A	ALARM & SIGNAL-LO AIR PRIM.	24 F	RR JCT BOX 24V DISC SW	29 B	A/C & HEAT SYSTEM-DRIVER'S HTR
11 K	FR DESTINATION SIGN	13 B	ALARM & SIGNAL-LO AIR SEC.	24 G	FR JCT BOX 24V DISC SW	29 H	HVAC DASH MODULE
12	12V BAT ELECTRICAL JCT BLOCK	14	LAVATORY-FLUSHING PUMP	24 G	RR JCT BOX 24V DISC SW	30 A	GALLEY
12	BAT CPT 12V BATTERY	14 A	LAVATORY-FLUSHING PUMP	24 H	FR JCT BOX 24V DISC SW	31 A	A/C & HEAT SYSTEM-UNLOADER
12 A	FR JCT BOX 12V DISC SW	15	EXTERIOR LTS-MULTI FUNC LEVEL	24 H	RR JCT BOX 24V DISC SW	31 B	A/C & HEAT SYSTEM-UNLOADER
12 A	RR JCT BOX 12V DISC SW	15 A	WIPER & WASHER UPPER WINDSHIELD	24 I	FR JCT BOX 24V IGNITION	31 B	WIPER & WASHER SYSTEM
12 B	12V BAT ELECTRICAL JCT BLOCK	16	SPEED - SIGNAL +	24 I	RR JCT BOX 24V IGNITION	31 C	WIPER & WASHER SYSTEM
12 B	RR JCT BOX 12V DISC SW	16 A	SPEED - SIGNAL +	24 IA	FR JCT BOX 24V IGNITION	31 D	WIPER & WASHER SYSTEM
12 B	FR JCT BOX 12V DISC SW	16 T	SPEED - SIGNAL +	24 IA	RR JCT BOX 24V IGNITION	31 E	WIPER & WASHER SYSTEM
12 BE	BAT. EQUALIZER MONITOR	17	EXTERIOR LTS-FLASHER UNIT	24 IB	FR JCT BOX 24V IGNITION	31 J	WIPER & WASHER SYSTEM
12 C	FR JCT BOX 12V DISC SW	17 A	EXTERIOR LTS-FLASHER UNIT	24 IB	RR JCT BOX 24V IGNITION	31 X	WIPER & WASHER SYSTEM
12 C	RR JCT BOX 12V HOT WIRE	19	DIFFERENTIAL OIL TEMP	24 IC	FR JCT BOX 24V IGNITION	32	EXTERIOR LTS-BACK-UP
12 CE	RR JCT BOX 12V HOT WIRE	20	SPEED - SIGNAL -	24 IF	FJB 24VOLT IGNITION	32 B	EXTERIOR LTS-BACK-UP
12 D	BAT CPT 12V BATTERY	20 T	SPEED - SIGNAL -	24 P	FR JCT BOX 24V DISC SW	32 C	BACK-UP PWR & SIGNAL
12 DT	TTLT MODULE	20 W	SPEED - SIGNAL -	24 S	24V DISC SW RLY SIGNAL	32 D	BACK-UP ALARM
12 E	FR JCT BOX 12V DISC SW	21	EXTERIOR LTS-DIRECTIONNAL LH	24 S1	SOUND SYSTEM 24V AMPLIFIER	35	ENTRANCE DOOR (SEDAN)
12 E	RR JCT BOX 12V DISC SW	21 A	EXTERIOR LTS-DIRECTIONNAL LH	24 S2	SOUND SYSTEM 24V AMPLIFIER	35 B	ENTRANCE DOOR (SEDAN)
12 F	BAT CPT 12V FJB & IC	21 B	EXTERIOR LTS-HAZARD	24 S3	SOUND SYSTEM 24V VIDEO	35 BB	ENTRANCE DOOR (SEDAN)
12 F	FR JCT BOX 12V DISC SW	21 C	EXTERIOR LTS-CORNERING LH	24 S4	SOUND SYSTEM 24V VIDEO	35 D	ENTRANCE DOOR (SEDAN)
12 F	RR JCT BOX 12V DISC SW	21 H	EXTERIOR LTS-DIRECTIONNAL LH	24 SB	SOUND SYSTEM 24V FEEDING	36	JACOB BRAKE SYSEM



# CIRCUIT NUMBER CODE

No.	DESCRIPTION	No.	DESCRIPTION	No.	DESCRIPTION	No.	DESCRIPTION
36 A	JACOB BRAKE SYSREM	53 J	WIPER & WASHER SYSTEM	72 D	SUN VISOR-LH	92	BATTERY EQUALIZER-CHECK BALANCE
38	INTERIOR LTS-24V FLUORESCENT	55	EXTERIOR LTS-HI BEAM	73	LAVATORY-FEEDING	93	BATTERY EQUALIZER-CHECK LO/HI
38 A	INTERIOR LTS-24V FLUORESCENT	57	EXTERIOR LTS-HI BEAM	74	INTERIOR LTS-READING RH	95 A	ENGINE BRAKE & RETARDER SYSTEM
38 C	INTERIOR LTS-24V FLUORESCENT	57 A	A/C & HEAT SYSTEM-WATER PUMP	74 A	INTERIOR LTS-READING RH	97	TACHOMETER (-)
38 D	INTERIOR LTS-24V FLUORESCENT	57 A	EXTERIOR LTS-HI BEAM	74 D	INTERIOR LTS-READING SIGNAL	100	INTERIOR LTS-GENERAL
39	INTERIOR LTS-24V LH CONSOLE SW	57 B	A/C & HEAT SYSTEM-WATER PUMP	75	INTERIOR LTS-READING LH	100 A	INTERIOR LTS-GENERAL
39 A	INTERIOR LTS-DRIVER'S LTS	57 C	PRE-HEAT WATER HEATER	75 A	INTERIOR LTS-READING LH	100 B	INTERIOR LTS-GENERAL
39 P	READING LIGHTS	57 CA	A/C & HEAT SYSTEM-HEAT SIGN	76	FUEL TANK GAUGE	101	24V STARTER SOL FEEDING
41	A/C & HEAT SYSTEM-COND FAN MOT	57 CC	A/C & HEAT SYSTEM-HEAT SIGN	76 B	LOW FUEL LT & ETHER COLD START	101	WORLD TRANSM-LO SIGN SOL. LO
41 A	A/C & HEAT SYSTEM-COND FAN MOT	58	EXTERIOR LTS-LO BEAM	76 C	LOW FUEL LT	102	WORLD TRANSM-SOL. SUPPLY
41 B	A/C & HEAT SYSTEM-COND FAN MOT	58 A	EXTERIOR LTS-LO BEAM	76 P	FUEL PRIME PUMP	102 A	24V STARTER TO BOSCH ALTERNATOR
42	A/C & HEAT SYSTEM-COND FAN MOT	58 B	EXTERIOR LTS-LO BEAM	76 M	FUEL PRIME PUMP	103	LOW BUOY
42 A	A/C & HEAT SYSTEM-COND FAN MOT	58 E	EXTERIOR LTS-LO BEAM	77	A/C & HEAT SYSTEM-HI PRESSURE	104	WORLD TRANSM-SOL. FORWARD
43	HAT RACK FAN	59 A	JACOB BRAKE SYSTEM	77 A	A/C & HEAT SYSTEM-DRIVER'S HTR	105	WORLD TRANSM-RETARDER & SUMP
43 A	HAT RACK FAN	61	EXTERIOR LTS-24V FEED SW	77 B	A/C & HEAT SYSTEM-COMPRESSOR	105 W	WORLD TRANSM-RETARDER & SUMP
43 B	HAT RACK FAN	61 A	EXTERIOR LTS-HEAD SIGNAL	77 C	A/C & HEAT SYSTEM-COMPRESSOR	106	WORLD TRANSM-OIL LEVEL HI
43 D	HAT RACK FAN	62	LAVATORY-OCCUPIED LT	77 H	A/C & HEAT SYSTEM-COMPRESSOR	107	WORLD TRANSM-LOCKUP SOL. HI
43 E	HAT RACK FAN	62 A	LAVATORY-FLUOR LT	81	EXTERIOR LTS-STOP SW	108	WORLD TRANSM-REM. PWR WAKE UP
43 F	HAT RACK FAN	62 B	LAVATORY-FLUOR LT	82	EXTERIOR LTS-STOP SIGNAL	109	WORLD TRANSM-RET. SOL. LO
43 G	HAT RACK FAN	62 E	LAVATORY-OCCUP & FLUOR LT	82 A	EXTERIOR LTS-STOP SIGNAL	110	ALARM & SIGNAL-WATER TEMP
44	EXTERIOR LTS-FOG	63	EXTERIOR LTS-CLEARANCE	82 B	EXTERIOR LTS-STOP LTS	110	WORLD TRANSM-LOCKUP SOL. LO
44 A	EXTERIOR LTS-FOG	63 A	EXTERIOR LTS-CLEARANCE	82 K	EXTERIOR LTS-STOP PARK BRK	111	WORLD TRANSM-SOL. C6
44 B	EXTERIOR LTS-FOG	63 B	EXTERIOR LTS-CLEARANCE	82 L	EXTERIOR LTS-LH STOP	112	WORLD TRANSM-SPARE OUTPUT (+)
44 C	EXTERIOR LTS-FOG & HAZARD	63 C	EXTERIOR LTS-MARKER SIGNAL	82 R	EXTERIOR LTS-LH STOP	113	ALARM & SIGNAL-OIL PRESS
45 B	A/C & HEAT SYSTEM-HEAT SIGN	63 D	EXTERIOR LTS-MARKER & TAIL	83	ENGINE CTR-KEY SW ACCES SIGN	113	WORLD TRANSM-REVERSE WARNING
45 D	A/C & HEAT SYSTEM-WATER VALVE	63 E	EXTERIOR LTS-CLEARANCE	84	ENGINE CTR-KEY SW ACCES SIGN	114	INTERIOR LTS-DASH LT REGUL.
45 E	A/C & HEAT SYSTEM-HEAT 1 SIGN	63 F	EXTERIOR LTS-MARKER BLINKER	85	ENGINE CTR-KEY SWIGNITION SIGN	114	WORLD TRANSM-SPARE OUTPUT (-)
45 G	A/C & HEAT SYSTEM-DRIVER'S HTR	63 H	EXTERIOR LTS-TAIL	85	24V IGNITION SIGNAL	114 A	INTERIOR LTS-DASH LT
45 H	A/C & HEAT SYSTEM-DRIVER'S HTR	64	DRIVERS FAN	85 A	24V IGN DASH INSTRUMENTATION	114 B	INTERIOR LTS-DASH LT REGUL.
45 W	A/C & HEAT SYSTEM-COND. DOOR AJAR	64 B	DRIVERS FAN	85 B	ENGINE CTR-24V IGNITION	114 D	INTERIOR LTS-DASH LT REGUL.
46	EXTERIOR LTS-MARKER	64 C	DRIVERS FAN	85 C	PARKING BRAKE SWITCH	114 E	INTERIOR LTS-DASH LT REGUL.
46 A	EXTERIOR LTS-MARKER	65	FOOT DAMPER MOTOR	85 F	ENGINE CTR-ENGINE CTR SW IGN	115	ALARM & SIGNAL-TAG PRESS
46 B	EXTERIOR LTS-MARKER	65 A	FOOT DAMPER MOTOR	85 F	LO AIR SONALERT	115	DDEC III-COOLANT LEVEL
46 B	EXTERIOR LTS-MARKER	65 P	PASSENGER REC. DAMPER	85 W	24V IGN ANTI SKID	115	WORLD TRANSM-DO NOT SHIFT SIGN
46 C	EXTERIOR LTS-MARKER	65 D	DRIVER REC. DAMPER	85 X	24V IGN ANTI SKID	115 C	DDEC III-COOLANT LEVEL
47	A/C & HEAT SYSTEM-DRIVER'S HTR	66	O_PASS. ON/OFF	85 Y	ANTI SKID-WARNING LT	115 W	WORLD TRANSM-DO NOT SHIFT SIGN
48	ENTRANCE DOOR (SEDAN)	67	24 VOLT RUN DISTRIBUTION	86	ENGINE CTR-STARTER SOL SIGN	116	WORLD TRANSM-LO SIGNAL SOL. HI
48 A	ENTRANCE DOOR (SEDAN)	67 A	A/C & HEAT SYSTEM	86 A	ENGINE CTR-STARTER SOL SIGN	116 B	A/C & HEAT SYSTEM-DRIVER'S HTR
49	ENTRANCE DOOR (SEDAN)	67 B	A/C & HEAT SYSTEM	88	ENGINE CTR-RR START SIGNAL	117	WORLD TRANSM-SPARE INPUT (-)
49 A	ENTRANCE DOOR (SEDAN)	67 C	HEATING WINDSHIELD	89	ENGINE CTR-RR START SIGNAL	117 A	ALARM & SIGNAL-TRANSM OIL TEMP
50	AIR DRYER	67 K	A/C & HEAT SYSTEM-COND FAN CTR	90 B	A/C & HEAT SYSTEM-COND FAN MOT	117 A	ALARM & SIGNAL-TRANSM OIL TEMP
52	ALARM & SIGNAL-ELEC. HORN	67 L	A/C & HEAT SYSTEM-COND FAN CTR	90 B	ENGINE CTR-MAST KEY SW FEED	118	WORLD TRANSM-SPARE INPUT (+)
52 A	ALARM & SIGNAL-ELEC. HORN	67 V	A/C & HEAT SYSTEM-WATER VALVE	90 C	A/C & HEAT SYSTEM-COND FAN MOT	119	WORLD TRANSM-ENG BRK INPUT (+)
52 B	ALARM & SIGNAL- AIR HORN	68	DASH & DEFROST DAMPER MOTOR	90 F	CHARG SYST-VOLTAGE REGUL. "B"	120	WORLD TRANSM-SOL. C1
52 C	ALARM & SIGNAL- AIR HORN	68 A	DASH & DEFROST DAMPER MOTOR	90 H	A/C & HEAT SYSTEM-EVAP FAN MOT	121	WORLD TRANSM-SOL. GRD 2
53	ALARM & SIGNAL-ELEC. HORN	70	INTERIOR LTS-HAT RACK & RR RUN.	90 J	A/C & HEAT SYSTEM-COND FAN MOT	122	A/C & HEAT SYSTEM-DRIVER'S HTR
53 A	WIPER & WASHER SYSTEM	72	SUN VISOR-FEEDING	91	PARKING BRAKE SW SIGNAL	122	A/C & HEAT SYSTEM-FRESH AIR
53 B	WIPER & WASHER SYSTEM	72 A	SUN VISOR-RH	91 A	DDEC-FAST IDLE SIGNAL	122	WORLD TRANSM-SOL. GRD 4
53 C	WIPER & WASHER SYSTEM	72 B	SUN VISOR-RH	91 S	SONALERT PARKING BRAKE	122 A	A/C & HEAT SYSTEM-FRESH AIR
53 E	WIPER & WASHER SYSTEM	72 C	SUN VISOR-LH	91 W	PARK, BRAKE SW SIGN (WCL)	123	WORLD TRANSM-NEUTRAL START

# CIRCUIT NUMBER CODE

No.	DESCRIPTION	No.	DESCRIPTION	No.	DESCRIPTION	No.	DESCRIPTION
123 A	ALARM & SIGNAL-FIRE DETECTOR	135 D	A/C & HEAT SYSTEM-AIR SENSOR	150	DDEC III-ECM BATTERY GRD	181 C	THERMOMETER OUTSIDE SENSOR
123 B	ALARM & SIGNAL-FIRE DETECTOR	135 C	A/C & HEAT SYSTEM-AIR SENSOR	150	WORLD TRANSM-ENGINE SPEED LO	181 D	THERMOMETER OUTSIDE SENSOR
124	WORLD TRANSM-THROTTLE (HI)	135	WORLD TRANSM-ANALOG GRD	150 A	DDEC III-ECM BATTERY GRD	197	FUEL WATER FILTER
125	WORLD TRANSM-RET. INDICATOR	135 D	WORLD TRANSM-RETARDER RES MOD	151	ABS SYSTEM	197 A	FUEL WATER FILTER
125	GALLEY LAMP	135 C	WORLD TRANSM-RETARDER TEMP	151	DDEC III-ECM BATTERY GRD	197 B	FUEL WATER FILTER
125 T	GALLEY LAMP	136	GALLEY-ACCESSORIES	151	WORLD TRANSM-SERIAL COM. B	198	FILTER FUEL HEATER
125 W	WORLD TRANSM-RET. INDICATOR	136	WORLD TRANSM-ECU POWER	151 A	ABS SYSTEM	199	AIR FILTER RESTRICTION SENDER
126	KNEELING SYSTEM	136 V	WORLD TRANSM-12V BATTERY	152	ABS SYSTEM	201	WORLD TRANSM-SPARE
126 A	KNEELING SYSTEM	136 W	WORLD TRANSM-12V BATTERY	152 A	ABS SYSTEM	202	WORLD TRANSM-SPARE
126 B	KNEELING SYSTEM	136 X	WORLD TRANSM-12V BATTERY	153	ABS SYSTEM	203	WORLD TRANSM-SPARE
126 C	KNEELING SYSTEM	137	WORLD TRANSM-RETARDER	153	WORLD TRANSM-SPARE INPUT (-)	204	WORLD TRANSM-SPARE
126 D	KNEELING SYSTEM	137 A	MIRROR (SPARTAN & RAMCO)	154	ABS SYSTEM	205	WORLD TRANSM-SPARE
126 E	KNEELING SYSTEM	137 B	RR VIEW MIRROR (SPARTAN)	154	WORLD TRANSM-ABS RET. INPUT	206	WORLD TRANSM-SPARE
126 F	KNEELING SYSTEM	137 C	RR VIEW MIRROR (SPARTAN)	155	ABS SYSTEM	214	WORLD TRANSM-BACK UP SIGNAL
126 G	KNEELING SYSTEM	137 D	RR VIEW MIRROR (SPARTAN)	155	WORLD TRANSM-SPARE INPUT (-)	225	LAVATORY FAN
126 H	KNEELING SYSTEM	137 E	RR VIEW MIRROR (SPARTAN)	156	ABS SYSTEM	225 A	LAVATORY FAN
126 K	KNEELING SYSTEM	137 G	RR VIEW MIRROR (SPARTAN)	156	WORLD TRANSM-THROTTLE POS.	231	NEUTRAL SIGNAL GRD
126 P	KNEELING SYSTEM	138	ABS SYSTEM	156 A	ABS SYSTEM	231 A	NEUTRAL COIL RELAY FEED SIGNAL
126 R	KNEELING SYSTEM	138	WORLD TRANSM-RETARDER TEMP	157	ABS SYSTEM	231 W	NEUTRAL SIGNAL GRD (WCL)
126 W	5 MPH N.C. SIGNAL (WCL)	138 A	ABS SYSTEM	157	WORLD TRANSM-SPEEDO SIGNAL	240	DDEC III-ECM 12V FEEDING
126 S	KNEELING SYSTEM	139	ABS SYSTEM	157 A	ABS SYSTEM	241	DDEC III-ECM 12V FEEDING
126 T	KNEELING SYSTEM	139	WORLD TRANSM-OUTPUT SPEED HI	157 B	ABS SYSTEM	251 A	DDEC III - DATA LOGGER 12 H.W.
127	WORLD TRANSM-LUBE PRESS SW.	140	ABS SYSTEM	157 D	A.T.C. SYSTEM	251	DDEC III - PRODRIVER 12V H.W.
127	PRE-HEAT WATER HEATER	140	WORLD TRANSM-OUTPUT SPEED LO	157 E	A.T.C. SYSTEM	253	GALLEY-MICROWAVE
127 A	PRE-HEAT WATER HEATER	141	ABS SYSTEM	158	WORLD TRANSM-DIMMER	254	GALLEY-12V FRIGO NORCOLD
127 B	PRE-HEAT WATER HEATER	141	WORLD TRANSM-ENGINE SPEED HI	160	ALARM & SIGNAL-TAG PRESS SW	254 A	GALLEY-FRIGO
127	WORLD TRANSM-RETARDER FEED SOL.	142	ABS SYSTEM	160	WORLD TRANSM-SER. INTERFACE (-)	255	GALLEY-COFEEMAKER
127 S	PRE-HEAT WATER HEATER	142	WORLD TRANSM-SERIAL COM. A	161	WORLD TRANSM-SIGNAL GRD	255 A	GALLEY-COFEEMAKER
127 W	PRE-HEAT WATER HEATER	143	ABS SYSTEM	161 B	WORLD TRANSM-SIGNAL GRD	257	WINDSHIELD HEATED
128	PRE-HEAT WATER HEATER	143	WORLD TRANSM-ECU BATTERY GRD	162	WORLD TRANSM-PRESS. SW C3	257 A	WINDSHIELD HEATED
128 A	PRE-HEAT WATER HEATER	143 A	ABS SYSTEM	163	WORLD TRANSM-RETARDER ENABLE	257 B	WINDSHIELD HEATED
128 B	PRE-HEAT WATER HEATER	143 W	WORLD TRANSM-BATTERY GRD	164	WORLD TRANSM-RET. ACTUATOR SIGN	257 C	WINDSHIELD HEATED
128 W	PRE-HEAT WATER HEATER	144	ABS SYSTEM	165	A/C & HEAT SYSTEM-TRANSMITER	257 D	WINDSHIELD HEATED SPARE
128	WORLD TRANSM-SOL. C2	144	WORLD TRANSM-ECU CHASSIS GRD	165	WORLD TRANSM-OIL LEVEL SIGNAL	257 E	WINDSHIELD HEATED SPARE
129	PRE-HEAT WATER HEATER	144 A	ABS SYSTEM	165 A	A/C & HEAT SYSTEM-TRANSMITER	258	WINDSHIELD HEATED
129	WORLD TRANSM-SOL. C5	145	ABS SYSTEM	165 B	A/C & HEAT SYSTEM-TRANSMITER	258 A	WINDSHIELD HEATED
130	WORLD TRANSM-SOL. GRD 3	146	ABS SYSTEM	165 C	A/C & HEAT SYSTEM-TRANSMITER	259	WINDSHIELD HEATED
131	WORLD TRANSM-SOL. C4	146 A	TRANSMISSION-12V IGNITION	165 D	A/C & HEAT SYSTEM-TRANSMITER	259 A	WINDSHIELD HEATED
132	WORLD TRANSM-ENG BRK OUTPUT (-)	146	WORLD TRANSM-IGNITION SENSE	166 B	A/C & HEAT SYSTEM-EVAP. MOD.	260	WINDOW AJAR
132 W	WORLD TRANSM-ENG BRK OUTPUT (-)	146 W	WORLD TRANSM-12V IGNITION	167	A/C & HEAT SYSTEM-TEMP. CTR	290	FAN CLUTCH RADIATOR
133	GALLEY-HEAT CONTAINERS	146 X	WORLD TRANSM-12V IGNITION	167 A	A/C & HEAT SYSTEM-TEMP. CTR	290	FAN CLUTCH RADIATOR
133 A	GALLEY-HEAT CONTAINERS	147	ABS SYSTEM	168	A/C & HEAT SYSTEM-HUMIDISTAT	291	FAN CLUTCH RADIATOR SPD 1
133 B	GALLEY-HEAT CONTAINERS	147	WORLD TRANSM-OIL TEMP	168	WORLD TRANSM-SER. INTERFACE (+)	292	FAN CLUTCH RADIATOR SPD 2
133 C	GALLEY-HEAT CONTAINERS	147 A	ETHER COLD START & D.R.L.	168 A	A/C & HEAT SYSTEM-HUMIDISTAT	300	DOOR AJAR MAGN.SW. (WCL)
133	WORLD TRANSM-RET. ACTUATOR HI	147 C	ETHER COLD START	170	LUGGAGE DOOR LOCK	300 A	POWER SYSTEM SW. (WCL)
134	GALLEY-HEAT CONTAINERS	148	ABS SYSTEM	170 C	LUGGAGE DOOR LOCK	300 B	DOOR AJAR ALARM (WCL)
134 A	GALLEY-HEAT CONTAINERS	148	WORLD TRANSM-OUTPUT SPEED LO	170 E	LUGGAGE DOOR LOCK	301	POWER SYSTEM SW. (WCL)
134	WORLD TRANSM-RET. APPLY SOL. HI	149	ABS SYSTEM	170 H	LUGGAGE DOOR LOCK	302	DOOR AJAR T.T.LT. (WCL)
135	A/C & HEAT SYSTEM-AIR SENSOR	149	WORLD TRANSM-TURBINE SPEED HI	181 A	THERMOMETER INSIDE SENSOR	302 A	DOOR AJAR ALARM SIGN.(WCL)
135 A	A/C & HEAT SYSTEM-AIR SENSOR	149 A	ABS SYSTEM	181 B	THERMOMETER INSIDE SENSOR	302 B	DOOR AJAR MAGN.SW. (WCL)

## CIRCUIT NUMBER CODE

No.	DESCRIPTION	No.	DESCRIPTION	No.	DESCRIPTION	No.	DESCRIPTION
303	REMOTE WALL SW. DWN (WCL)	555	DDEC III-FAN CLUTCH SPEED# 1				
304	REMOTE WALL SW. UP (WCL)	556	DDEC III-VEHICLE SPEED (+)				
305	PARK. BRAKE SOL. VALVE (WCL)	557	DDEC III-VEHICLE SPEED (-)				
305 A	PARK. BRAKE SAFETY SW. (WCL)	563	DDEC III-FAN CLUTCH SPEED# 2				
306	CONTROL SYSTEM (WCL RICON)	564	DDEC III-DIGITAL OUTPUT				
307	CONTROL SYSTEM (WCL RICON)	565	DDEC III-ENGINE BRAKE ACTIVE				
308	CONTROL SYSTEM (WCL RICON)	583	DDEC III-ENGINE BRAKE 4 CYL.				
309	CONTROL SYSTEM (WCL RICON)	900	DDEC III-DATA LINK (+)				
310	EATON TRANSMISSION	901	DDEC III-DATA LINK (-)				
311	EATON TRANSMISSION	908	DDEC III-HYDRAULIC PWM#1 OUTPUT				
312	EATON TRANSMISSION	916	DDEC III-SENSOR SUPPLY (5VDC)				
313	EATON TRANSMISSION	925	J1939-HIGH				
314	EATON TRANSMISSION	926	J1939-LOW				
315	EATON TRANSMISSION	927	J1939-SHIELD				
316	EATON TRANSMISSION - EPL	952	DDEC III-SENSOR RETURN				
317	EATON TRANSMISSION	953	DDEC III-BATTERY GRD				
318	EATON TRANSMISSION	979	DDEC III-ENGINE BRAKE 2 CYL.				
319	EATON TRANSMISSION						
320	EATON TRANSMISSION						
321	EATON TRANSMISSION						
322	EATON TRANSMISSION						
323	EATON TRANSMISSION						
324	EATON TRANSMISSION						
325	EATON TRANSMISSION						
326	EATON TRANSMISSION						
327	EATON TRANSMISSION						
328	EATON TRANSMISSION						
329	EATON TRANSMISSION						
330	EATON TRANSMISSION - EPL						
331	EATON TRANSMISSION - EPL						
332	EATON TRANSMISSION						
333	EATON TRANSMISSION - 12V BATTERY						
417	DDEC III-LIMIT SPEED GOVERNOR						
419	DDEC III-CHECK ENGINE LIGHT						
439	DDEC III-12V IGNITION						
440	DDEC III-12V IGNITION						
440 A	DDEC III-12V IGNITION						
451	DDEC III-A/C FAN CLUTCH						
505	DDEC III-TACHOMETER DRIVE						
509	DDEC III-STOP ENGINE LIGHT						
510	DDEC III-FAST IDLE SIGNAL						
524	DDEC III-ENGINE BRAKE DISABLE						
525	DDEC III-FAST IDLE SIGNAL						
528	DDEC III-STOP ENG. OVERRIDE						
531	DDEC III-CRUISE CLUTCH RELEASE						
540	DDEC III-CRUISE ENABLE LTS.						
541	DDEC III-CRUISE SET SW						
543	DDEC III-CRUISE STOP SW CUT IN						
544	DDEC III-CRUISE ON/OFF SW						
545	DDEC III-CRUISE RESUME SW						

# CIRCUIT BREAKERS CODE

No.	PAGE	AMP.	#PREV.	LOCATION	FUNCTION	No.	PAGE	AMP.	#PREV.	LOCATION	FUNCTION
CB 1	2	40A	560703	BAT. CPT.	12V IGNITION	CB 126	25.2	90A	560298	BAT. CPT.	WHELL CHAIR LIFT MOTOR PUMP RICON
CB 2	1.1	30A	870690	BAT. CPT.	12V HOT WIRE	CB 127	13.3	15A	561793	RR. JCT. BOX	HAT-RACK FAN L.H.
CB 3	1.1	40A	560703	BAT. CPT.	12V FEED RR. JCT. BOX	CB 128	13.3	15A	561793	RR. JCT. BOX	HAT-RACK FAN R.H.
CB 4	1.1	40A	560703	BAT. CPT.	12V FEED FR. JCT. BOX	CB 129	7.2	6A	561790	FR. JCT. BOX	CLUSTER
CB 5	1.1	30A	870690	BAT. CPT.	24V HOT WIRE	CB 130	28	6A	561790	FR. JCT. BOX	CLUSTER
CB 6	1.1	90A	560298	BAT. CPT.	24V FEED RR. JCT. BOX						
CB 7	1.1	90A	560298	BAT. CPT.	24V FEED FR. JCT. BOX						
CB 8	1.1	150A	560299	BAT. CPT.	24V EVAPORATOR FAN MOTOR						
CB 10	4	8A	561791	FR. JCT. BOX	MASTER KEY SWITCH						
CB 16	4	8A	561791	RR. JCT. BOX	ENGINE-RR. CTRL & START SW.						
CB 18	4	6A	561790	RR. JCT. BOX	ENGINE-FR. CTRL SW.						
CB 19	5	15A	561793	BAT. CPT.	E.C.M. DDEC III 12V POWER						
CB 20	5	15A	561793	BAT. CPT.	E.C.M. DDEC III 12V POWER						
CB 21	5	6A	561790	BAT. CPT.	E.C.M. DDEC III 12V IGNITION						
CB 24	6	20A	561794	BAT. CPT.	WORLD TRANSMISSION 12V POWER						
CB 26	9.3	10A	561792	RR. JCT. BOX	BACK-UP LTS						
CB 27	7	8A	561791	FR. JCT. BOX	24V IGNITION DASH ACCESSORIES						
CB 28	7	6A	561790	FR. JCT. BOX	12V IGNITION DASH ACCESSORIES						
CB 34	9.3	6A	561792	RR. JCT. BOX	BACK-UP ALARM						
CB 35	9.3	15A	561790	FR. JCT. BOX	FOG & HAZARD DASH SW.						
CB 37	9.1	6A	561790	FR. JCT. BOX	HEAD & MULTI-FUNCTION LEVEL SW.						
CB 38	9.1	10A	561792	FR. JCT. BOX	FR. MARKER LTS						
CB 39	9.1	20A	561794	FR. JCT. BOX	CLEARANCE & IDENTIFICATION LTS						
CB 40	9.1	8A	561791	FR. JCT. BOX	FR. CLEARANCE & IDENTIFICATION LTS						
CB 41	9.1	8A	561791	RR. JCT. BOX	RR. CLEARANCE & IDENTIFICATION LTS						
CB 42	9.1	8A	561791	RR. JCT. BOX	RR. TAIL & LICENCE LTS						
CB 43	9.1	20A	561794	FR. JCT. BOX	HEADLAMP (HI)						
CB 44	9.1	15A	561793	FR. JCT. BOX	HEADLAMP (LO)						
CB 45	9.2	10A	561792	FR. JCT. BOX	WIPER CTRL. MULTI-FUNCTION LEVEL SW.						
CB 46	9.2	20A	561794	FR. JCT. BOX	FLASHER & HAZARD UNIT						
CB 48	9.3	6A	561790	FR. JCT. BOX	STOP LTS PRESSURE SW.						
CB 49	9.3	15A	561793	RR. JCT. BOX	STOP & CYCLOP LTS						
CB 51	10	10A	561792	FR. JCT. BOX	UPPER WIPER CTRL SW.						
CB 52	11.1	15A	561793	RR. JCT. BOX	LUGGAGE & DOOR AJAR LTS						
CB 57	11.2	8A	561791	FR. JCT. BOX	DASH LTS RHEOSTAT						
CB 58	13.1	6A	561790	FR. JCT. BOX	HVAC DASH MODULE						
CB 63	11.4	8A	561791	FR. SERVICE.CPT	110V FLUORESCENT LH						
CB 64	11.4	8A	561791	FR. SERVICE.CPT	110V FLUORESCENT RH						
CB 70	13.1	6A	561790	FR. JCT. BOX	A/C & HEAT SW.						
CB 71	13.1	10A	561792	RR. JCT. BOX	A/C & HEAT LOGIC PANEL						
CB 72	13.1	10A	561792	RR. JCT. BOX	A/C COMPRESSOR CLUTCH						
CB 73	13.1	15A	561793	RR. JCT. BOX	WATER PUMP						
CB 77	13.2	40A	560703	BAT. CPT.	CONDENSER FAN MOTOR RH						
CB 78	13.2	40A	560703	BAT. CPT.	CONDENSER FAN MOTOR LH						
CB 79	13.2	15A	561793	FR. JCT. BOX	DRIVER'S HTR FAN SPEED CTRL MODULE						
CB 85	11.2	10A	561790	FR. JCT. BOX	ENTRANCE DOOR (SEDAN) & STEP LTS						
CB 93	1.2	30A	870690	BAT. CPT.	SOUND SYSTEM 12V FEEDING						
CB 94	1.2	30A	870690	BAT. CPT.	SOUND SYSTEM 12V FEEDING						
CB 95	20.1	10A	561792	S.S. JCT. PANEL	SOUND SYSTEM AMPLI						
CB 96	20.1	10A	561792	S.S. JCT. PANEL	VIDEO SYSTEM						
CB 97	20.1	10A	561792	S.S. JCT. PANEL	SOUND SYSTEM B/U P.A. AMPLI						
CB 98	20.1	15A	561793	S.S. JCT. PANEL	SOUND SYSTEM RADIO & CD						
CB 99	20.7	15A	561793	S.S. JCT. PANEL	SEAT AUDIO SYSTEM						
CB 105	21	6A	561790	FR. JCT. BOX	E.C.U. ABS						
CB 106	21	10A	561792	FR. JCT. BOX	E.C.U. ABS						
CB 107	21	10A	561792	FR. JCT. BOX	E.C.U. ABS						
CB 124	8	6A	561790	RR. JCT. BOX	RADIATOR FAN CLUTCH						
CB 126	25.1	150A	560299	BAT. CPT.	WHELL CHAIR LIFT MOTOR PUMP STE.						

# CIRCUIT BREAKERS CODE

No.	PAGE	AMP.	#PREV.	LOCATION	FUNCTION	No.	PAGE	AMP.	#PREV.	LOCATION	FUNCTION
CB 1	2	40A	560703	BAT. CPT.	12V IGNITION	CB 126	25.2	90A	560298	BAT. CPT.	WHELL CHAIR LIFT MOTOR PUMP RICON
CB 2	1.1	40A	870093	BAT. CPT.	12V HOT WIRE	CB 127	13.3	15A	561793	RR. JCT. BOX	HAT-RACK FAN L.H.
CB 3	1.1	40A	560703	BAT. CPT.	12V FEED RR. JCT. BOX	CB 128	13.3	15A	561793	RR. JCT. BOX	HAT-RACK FAN R.H.
CB 4	1.1	40A	560703	BAT. CPT.	12V FEED FR. JCT. BOX	CB 129	7.2	6A	561790	FR. JCT. BOX	CLUSTER
CB 5	1.1	30A	870690	BAT. CPT.	24V HOT WIRE	CB 130	28	6A	561790	FR. JCT. BOX	CLUSTER
CB 6	1.1	90A	560298	BAT. CPT.	24V FEED RR. JCT. BOX						
CB 7	1.1	90A	560298	BAT. CPT.	24V FEED FR. JCT. BOX						
CB 8	1.1	150A	560299	BAT. CPT.	24V EVAPORATOR FAN MOTOR						
CB 10	4	8A	561791	FR. JCT. BOX	MASTER KEY SWITCH						
CB 16	4	8A	561791	RR. JCT. BOX	ENGINE-RR. CTRL & START SW.						
CB 18	4	6A	561790	RR. JCT. BOX	ENGINE-FR. CTRL SW.						
CB 19	5	15A	561793	BAT. CPT.	E.C.M. DDEC 12V POWER						
CB 20	5	15A	561793	BAT. CPT.	E.C.M. DDEC 12V POWER						
CB 21	5	6A	561790	BAT. CPT.	E.C.M. DDEC 12V IGNITION						
CB 24	6	25A	561794	BAT. CPT.	WORLD TRANSMISSION & EATON 12V POWER						
CB 26	9.3	10A	561792	RR. JCT. BOX	BACK-UP LTS						
CB 27	7	8A	561791	FR. JCT. BOX	24V IGNITION DASH ACCESSORIES						
CB 28	7	6A	561790	FR. JCT. BOX	12V IGNITION DASH ACCESSORIES						
CB 34	9.3	6A	561792	RR. JCT. BOX	BACK-UP ALARM						
CB 35	9.3	15A	561790	FR. JCT. BOX	FOG & HAZARD DASH SW.						
CB 37	9.1	6A	561790	FR. JCT. BOX	HEAD & MULTI-FUNCTION LEVEL SW.						
CB 38	9.1	10A	561792	FR. JCT. BOX	FR. MARKER LTS						
CB 39	9.1	20A	561794	FR. JCT. BOX	CLEARANCE & IDENTIFICATION LTS						
CB 40	9.1	8A	561791	FR. JCT. BOX	FR. CLEARANCE & IDENTIFICATION LTS						
CB 41	9.1	8A	561791	RR. JCT. BOX	RR. CLEARANCE & IDENTIFICATION LTS						
CB 42	9.1	8A	561791	RR. JCT. BOX	RR. TAIL & LICENCE LTS						
CB 43	9.1	20A	561794	FR. JCT. BOX	HEADLAMP (HI)						
CB 44	9.1	15A	561793	FR. JCT. BOX	HEADLAMP (LO)						
CB 45	9.2	10A	561792	FR. JCT. BOX	WIPER CTRL. MULTI-FUNCTION LEVEL SW.						
CB 46	9.2	20A	561794	FR. JCT. BOX	FLASHER & HAZARD UNIT						
CB 48	9.3	6A	561790	FR. JCT. BOX	STOP LTS PRESSURE SW.						
CB 49	9.3	15A	561793	RR. JCT. BOX	STOP & CYCLOP LTS						
CB 51	10	10A	561792	FR. JCT. BOX	UPPER WIPER CTRL SW.						
CB 52	11.1	15A	561793	RR. JCT. BOX	LUGGAGE & DOOR AJAR LTS						
CB 57	11.2	8A	561791	FR. JCT. BOX	DASH LTS RHEOSTAT						
CB 58	13.1	6A	561790	FR. JCT. BOX	HVAC DASH MODULE						
CB 63	11.4	8A	561791	FR. SERVICE.CPT	110V FLUORESCENT LH						
CB 64	11.4	8A	561791	FR. SERVICE.CPT	110V FLUORESCENT RH						
CB 70	22.1	6A	561790	FR. JCT. BOX	UPPER HEATING WINDSHIELD SW.						
CB 71	13.1	10A	561792	RR. JCT. BOX	A/C & HEAT LOGIC PANEL						
CB 72	13.2	10A	561792	RR. JCT. BOX	A/C COMPRESSOR CLUTCH						
CB 73	13.2	15A	561793	RR. JCT. BOX	WATER PUMP						
CB 77	13.1	40A	870093	BAT. CPT.	CONDENSER FAN MOTOR RH						
CB 78	13.1	40A	870093	BAT. CPT.	CONDENSER FAN MOTOR LH						
CB 79	13.2	15A	561793	FR. JCT. BOX	DRIVER'S HTR FAN SPEED CTRL MODULE						
CB 85	11.2	10A	561790	FR. JCT. BOX	ENTRANCE DOOR (SEDAN) & STEP LTS						
CB 93	1.2	30A	870690	BAT. CPT.	SOUND SYSTEM 12V FEEDING						
CB 94	1.2	30A	870690	BAT. CPT.	SOUND SYSTEM 12V FEEDING						
CB 95	20.1	10A	561792	S.S. JCT. PANEL	SOUND SYSTEM AMPLI						
CB 96	20.1	10A	561792	S.S. JCT. PANEL	VIDEO SYSTEM						
CB 97	20.1	10A	561792	S.S. JCT. PANEL	SOUND SYSTEM B/U P.A. AMPLI						
CB 98	20.1	15A	561793	S.S. JCT. PANEL	SOUND SYSTEM RADIO & CD						
CB 99	20.7	15A	561793	S.S. JCT. PANEL	SEAT AUDIO SYSTEM						
CB 105	21	6A	561790	FR. JCT. BOX	E.C.U. ABS						
CB 106	21	10A	561792	FR. JCT. BOX	E.C.U. ABS						
CB 107	21	10A	561792	FR. JCT. BOX	E.C.U. ABS						
CB 124	8	6A	561790	RR. JCT. BOX	RADIATOR FAN CLUTCH						
CB 126	25.1	150A	560299	BAT. CPT.	WHELL CHAIR LIFT MOTOR PUMP STE.						

# CIRCUIT BREAKERS CODE

No.	PAGE	AMP.	#PREV.	LOCATION	FUNCTION	No.	PAGE	AMP.	#PREV.	LOCATION	FUNCTION
CB 1	2	40A	560703	BAT. CPT.	12V IGNITION	CB 126	25.2	90A	560298	BAT. CPT.	WHELL CHAIR LIFT MOTOR PUMP RICON
CB 2	1.1	40A	870093	BAT. CPT.	12V HOT WIRE	CB 127	13.3	15A	561793	RR. JCT. BOX	HAT-RACK FAN L.H.
CB 3	1.1	40A	560703	BAT. CPT.	12V FEED RR. JCT. BOX	CB 128	13.3	15A	561793	RR. JCT. BOX	HAT-RACK FAN R.H.
CB 4	1.1	40A	560703	BAT. CPT.	12V FEED FR. JCT. BOX	CB 129	7.2	6A	561790	FR. JCT. BOX	CLUSTER
CB 5	1.1	30A	870690	BAT. CPT.	24V HOT WIRE	CB 130	28	6A	561790	FR. JCT. BOX	CLUSTER
CB 6	1.1	90A	560298	BAT. CPT.	24V FEED RR. JCT. BOX						
CB 7	1.1	90A	560298	BAT. CPT.	24V FEED FR. JCT. BOX						
CB 8	1.1	150A	560299	BAT. CPT.	24V EVAPORATOR FAN MOTOR						
CB 10	4	8A	561791	FR. JCT. BOX	MASTER KEY SWITCH						
CB 16	4	8A	561791	RR. JCT. BOX	ENGINE-RR. CTRL & START SW.						
CB 18	4	6A	561790	RR. JCT. BOX	ENGINE-FR. CTRL SW.						
CB 19	5	15A	561793	BAT. CPT.	E.C.M. DDEC 12V POWER						
CB 20	5	15A	561793	BAT. CPT.	E.C.M. DDEC 12V POWER						
CB 21	5	10A	561792	RR. JCT. BOX	E.C.M. DDEC and WTEC 12V IGNITION						
CB 24	6	25A	561794	BAT. CPT.	WORLD TRANSMISSION & EATON 12V POWER						
CB 26	9.3	10A	561792	RR. JCT. BOX	BACK-UP LTS						
CB 27	7	8A	561791	FR. JCT. BOX	24V IGNITION DASH ACCESSORIES						
CB 28	7	6A	561790	FR. JCT. BOX	12V IGNITION DASH ACCESSORIES						
CB 34	9.3	6A	561792	RR. JCT. BOX	BACK-UP ALARM						
CB 35	9.3	15A	561790	FR. JCT. BOX	FOG & HAZARD DASH SW.						
CB 37	9.1	6A	561790	FR. JCT. BOX	HEAD & MULTI-FUNCTION LEVEL SW.						
CB 38	9.1	10A	561792	FR. JCT. BOX	FR. MARKER LTS						
CB 39	9.1	20A	561794	FR. JCT. BOX	CLEARANCE & IDENTIFICATION LTS						
CB 40	9.1	8A	561791	FR. JCT. BOX	FR. CLEARANCE & IDENTIFICATION LTS						
CB 41	9.1	8A	561791	RR. JCT. BOX	RR. CLEARANCE & IDENTIFICATION LTS						
CB 42	9.1	8A	561791	RR. JCT. BOX	RR. TAIL & LICENCE LTS						
CB 43	9.1	20A	561794	FR. JCT. BOX	HEADLAMP (HI)						
CB 44	9.1	15A	561793	FR. JCT. BOX	HEADLAMP (LO)						
CB 45	9.2	10A	561792	FR. JCT. BOX	WIPER CTRL. MULTI-FUNCTION LEVEL SW.						
CB 46	9.2	20A	561794	FR. JCT. BOX	FLASHER & HAZARD UNIT						
CB 48	9.3	6A	561790	FR. JCT. BOX	STOP LTS PRESSURE SW.						
CB 49	9.3	15A	561793	RR. JCT. BOX	STOP & CYCLOP LTS						
CB 51	10	10A	561792	FR. JCT. BOX	UPPER WIPER CTRL SW.						
CB 52	11.1	15A	561793	RR. JCT. BOX	LUGGAGE & DOOR AJAR LTS						
CB 57	11.2	8A	561791	FR. JCT. BOX	DASH LTS RHEOSTAT						
CB 58	13.1	6A	561790	FR. JCT. BOX	HVAC DASH MODULE						
CB 63	11.4	8A	561791	FR. SERVICE.CPT	110V FLUORESCENT LH						
CB 64	11.4	8A	561791	FR. SERVICE.CPT	110V FLUORESCENT RH						
CB 70	22.1	6A	561790	FR. JCT. BOX	UPPER HEATING WINDSHIELD SW.						
CB 71	13.1	10A	561792	RR. JCT. BOX	A/C & HEAT LOGIC PANEL						
CB 72	13.2	10A	561792	RR. JCT. BOX	A/C COMPRESSOR CLUTCH						
CB 73	13.2	15A	561793	RR. JCT. BOX	WATER PUMP						
CB 77	13.1	40A	870093	BAT. CPT.	CONDENSER FAN MOTOR RH						
CB 78	13.1	40A	870093	BAT. CPT.	CONDENSER FAN MOTOR LH						
CB 79	13.2	15A	561793	FR. JCT. BOX	DRIVER'S HTR FAN SPEED CTRL MODULE						
CB 85	11.2	10A	561790	FR. JCT. BOX	ENTRANCE DOOR (SEDAN) & STEP LTS						
CB 93	1.2	30A	870690	BAT. CPT.	SOUND SYSTEM 12V FEEDING						
CB 94	1.2	30A	870690	BAT. CPT.	SOUND SYSTEM 12V FEEDING						
CB 95	20.1	10A	561792	S.S. JCT. PANEL	SOUND SYSTEM AMPLI						
CB 96	20.1	10A	561792	S.S. JCT. PANEL	VIDEO SYSTEM						
CB 97	20.1	10A	561792	S.S. JCT. PANEL	SOUND SYSTEM B/U P.A. AMPLI						
CB 98	20.1	15A	561793	S.S. JCT. PANEL	SOUND SYSTEM RADIO & CD						
CB 99	20.7	15A	561793	S.S. JCT. PANEL	SEAT AUDIO SYSTEM						
CB 105	21	6A	561790	FR. JCT. BOX	E.C.U. ABS						
CB 106	21	10A	561792	FR. JCT. BOX	E.C.U. ABS						
CB 107	21	10A	561792	FR. JCT. BOX	E.C.U. ABS						
CB 124	8	6A	561790	RR. JCT. BOX	RADIATOR FAN CLUTCH						
CB 126	25.1	150A	560299	BAT. CPT.	WHELL CHAIR LIFT MOTOR PUMP STE.						

# CIRCUIT BREAKERS CODE

No.	PAGE	AMP.	#PREV.	LOCATION	FUNCTION	No.	PAGE	AMP.	#PREV.	LOCATION	FUNCTION
CB 1	2	40A	562686	BAT. CPT.	12V IGNITION	CB 126	25.2	90A	560298	BAT. CPT.	WHELL CHAIR LIFT MOTOR PUMP RICON
CB 2	1.1	40A	870093	BAT. CPT.	12V HOT WIRE	CB 127	13.3	15A	561793	RR. JCT. BOX	HAT-RACK FAN L.H.
CB 3	1.1	40A	562686	BAT. CPT.	12V FEED RR. JCT. BOX	CB 128	13.3	15A	561793	RR. JCT. BOX	HAT-RACK FAN R.H.
CB 4	1.1	70A	562687	BAT. CPT.	12V FEED FR. JCT. BOX	CB 129	7.2	6A	561790	FR. JCT. BOX	CLUSTER
CB 5	1.1	30A	870690	BAT. CPT.	24V HOT WIRE	CB 130	28	6A	561790	FR. JCT. BOX	CLUSTER
CB 6	1.1	90A	562683	BAT. CPT.	24V FEED RR. JCT. BOX						
CB 7	1.1	90A	562683	BAT. CPT.	24V FEED FR. JCT. BOX						
CB 8	1.1	150A	560299	BAT. CPT.	24V EVAPORATOR FAN MOTOR						
CB 10	4	8A	561791	FR. JCT. BOX	MASTER KEY SWITCH						
CB 16	4	8A	561791	RR. JCT. BOX	ENGINE-RR. CTRL & START SW.						
CB 18	4	6A	561790	RR. JCT. BOX	ENGINE-FR. CTRL SW.						
CB 19	5	15A	561793	BAT. CPT.	E.C.M. DDEC 12V POWER						
CB 20	5	15A	561793	BAT. CPT.	E.C.M. DDEC 12V POWER						
CB 21	5	10A	561792	RR. JCT. BOX	E.C.M. DDEC and WTEC 12V IGNITION						
CB 24	6	25A	561794	BAT. CPT.	WORLD TRANSMISSION & EATON 12V POWER						
CB 26	9.3	10A	561792	RR. JCT. BOX	BACK-UP LTS						
CB 27	7	8A	561791	FR. JCT. BOX	24V IGNITION DASH ACCESSORIES						
CB 28	7	6A	561790	FR. JCT. BOX	12V IGNITION DASH ACCESSORIES						
CB 34	9.3	6A	561792	RR. JCT. BOX	BACK-UP ALARM						
CB 35	9.3	15A	561790	FR. JCT. BOX	FOG & HAZARD DASH SW.						
CB 37	9.1	6A	561790	FR. JCT. BOX	HEAD & MULTI-FUNCTION LEVEL SW.						
CB 38	9.1	10A	561792	FR. JCT. BOX	FR. MARKER LTS						
CB 39	9.1	20A	561794	FR. JCT. BOX	CLEARANCE & IDENTIFICATION LTS						
CB 40	9.1	8A	561791	FR. JCT. BOX	FR. CLEARANCE & IDENTIFICATION LTS						
CB 41	9.1	8A	561791	RR. JCT. BOX	RR. CLEARANCE & IDENTIFICATION LTS						
CB 42	9.1	8A	561791	RR. JCT. BOX	RR. TAIL & LICENCE LTS						
CB 43	9.1	20A	561794	FR. JCT. BOX	HEADLAMP (HI)						
CB 44	9.1	15A	561793	FR. JCT. BOX	HEADLAMP (LO)						
CB 45	9.2	10A	561792	FR. JCT. BOX	WIPER CTRL. MULTI-FUNCTION LEVEL SW.						
CB 46	9.2	20A	561794	FR. JCT. BOX	FLASHER & HAZARD UNIT						
CB 48	9.3	6A	561790	FR. JCT. BOX	STOP LTS PRESSURE SW.						
CB 49	9.3	15A	561793	RR. JCT. BOX	STOP & CYCLOP LTS						
CB 51	10	10A	561792	FR. JCT. BOX	UPPER WIPER CTRL SW.						
CB 52	11.1	15A	561793	RR. JCT. BOX	LUGGAGE & DOOR AJAR LTS						
CB 57	11.2	8A	561791	FR. JCT. BOX	DASH LTS RHEOSTAT						
CB 58	13.1	6A	561790	FR. JCT. BOX	HVAC DASH MODULE						
CB 63	11.4	8A	561791	FR. SERVICE.CPT	110V FLUORESCENT LH						
CB 64	11.4	8A	561791	FR. SERVICE.CPT	110V FLUORESCENT RH						
CB 70	22.1	6A	561790	FR. JCT. BOX	UPPER HEATING WINDSHIELD SW.						
CB 71	13.1	10A	561792	RR. JCT. BOX	A/C & HEAT LOGIC PANEL						
CB 72	13.2	10A	561792	RR. JCT. BOX	A/C COMPRESSOR CLUTCH						
CB 73	13.2	15A	561793	RR. JCT. BOX	WATER PUMP						
CB 77	13.1	40A	870093	BAT. CPT.	CONDENSER FAN MOTOR RH						
CB 78	13.1	40A	870093	BAT. CPT.	CONDENSER FAN MOTOR LH						
CB 79	13.2	15A	561793	FR. JCT. BOX	DRIVER'S HTR FAN SPEED CTRL MODULE						
CB 85	11.2	10A	561790	FR. JCT. BOX	ENTRANCE DOOR (SEDAN) & STEP LTS						
CB 93	1.2	30A	870690	BAT. CPT.	SOUND SYSTEM 12V FEEDING						
CB 94	1.2	30A	870690	BAT. CPT.	SOUND SYSTEM 12V FEEDING						
CB 95	20.1	10A	561792	S.S. JCT. PANEL	SOUND SYSTEM AMPLI						
CB 96	20.1	10A	561792	S.S. JCT. PANEL	VIDEO SYSTEM						
CB 97	20.1	10A	561792	S.S. JCT. PANEL	SOUND SYSTEM B/U P.A. AMPLI						
CB 98	20.1	15A	561793	S.S. JCT. PANEL	SOUND SYSTEM RADIO & CD						
CB 99	20.7	15A	561793	S.S. JCT. PANEL	SEAT AUDIO SYSTEM						
CB 105	21	6A	561790	FR. JCT. BOX	E.C.U. ABS						
CB 106	21	10A	561792	FR. JCT. BOX	E.C.U. ABS						
CB 107	21	10A	561792	FR. JCT. BOX	E.C.U. ABS						
CB 124	8	6A	561790	RR. JCT. BOX	RADIATOR FAN CLUTCH						
CB 126	25.1	150A	560299	BAT. CPT.	WHELL CHAIR LIFT MOTOR PUMP STE.						



# CIRCUIT BREAKERS CODE

No.	PAGE	AMP.	#PREV.	LOCATION	FUNCTION	No.	PAGE	AMP.	#PREV.	LOCATION	FUNCTION
CB 1	2	40A	562686	BAT. CPT.	12V IGNITION	CB 126	25.2	90A	560298	BAT. CPT.	WHELL CHAIR LIFT MOTOR PUMP RICON
CB 2	1.1	40A	870093	BAT. CPT.	12V HOT WIRE	CB 127	13.3	15A	561793	RR. JCT. BOX	HAT-RACK FAN L.H.
CB 3	1.1	40A	562686	BAT. CPT.	12V FEED RR. JCT. BOX	CB 128	13.3	15A	561793	RR. JCT. BOX	HAT-RACK FAN R.H.
CB 4	1.1	70A	562687	BAT. CPT.	12V FEED FR. JCT. BOX	CB 129	7.2	6A	561790	FR. JCT. BOX	CLUSTER
CB 5	1.1	30A	870690	BAT. CPT.	24V HOT WIRE	CB 130	28	6A	561790	FR. JCT. BOX	CLUSTER
CB 6	1.1	90A	562683	BAT. CPT.	24V FEED RR. JCT. BOX	CB 131	4.2	6A	561790	RR. JCT. BOX	ALT. BOSCH
CB 7	1.1	90A	562683	BAT. CPT.	24V FEED FR. JCT. BOX	CB 132	4.2	6A	561790	RR. JCT. BOX	ALT. BOSCH
CB 8	1.1	150A	560299	BAT. CPT.	24V EVAPORATOR FAN MOTOR						
CB 10	4	8A	561791	FR. JCT. BOX	MASTER KEY SWITCH						
CB 16	4	8A	561791	RR. JCT. BOX	ENGINE-RR. CTRL & START SW.						
CB 18	4	6A	561790	RR. JCT. BOX	ENGINE-FR. CTRL SW.						
CB 19	5	15A	561793	BAT. CPT.	E.C.M. DDEC 12V POWER						
CB 20	5	15A	561793	BAT. CPT.	E.C.M. DDEC 12V POWER						
CB 21	5	10A	561792	RR. JCT. BOX	E.C.M. DDEC and WTEC 12V IGNITION						
CB 24	6	25A	561794	BAT. CPT.	WORLD TRANSMISSION & EATON 12V POWER						
CB 26	9.3	10A	561792	RR. JCT. BOX	BACK-UP LTS						
CB 27	7	8A	561791	FR. JCT. BOX	24V IGNITION DASH ACCESSORIES						
CB 28	7	6A	561790	FR. JCT. BOX	12V IGNITION DASH ACCESSORIES						
CB 34	9.3	6A	561792	RR. JCT. BOX	BACK-UP ALARM						
CB 35	9.3	15A	561790	FR. JCT. BOX	FOG & HAZARD DASH SW.						
CB 37	9.1	6A	561790	FR. JCT. BOX	HEAD & MULTI-FUNCTION LEVEL SW.						
CB 38	9.1	10A	561792	FR. JCT. BOX	FR. MARKER LTS						
CB 39	9.1	20A	561794	FR. JCT. BOX	CLEARANCE & IDENTIFICATION LTS						
CB 40	9.1	8A	561791	FR. JCT. BOX	FR. CLEARANCE & IDENTIFICATION LTS						
CB 41	9.1	8A	561791	RR. JCT. BOX	RR. CLEARANCE & IDENTIFICATION LTS						
CB 42	9.1	8A	561791	RR. JCT. BOX	RR. TAIL & LICENCE LTS						
CB 43	9.1	20A	561794	FR. JCT. BOX	HEADLAMP (HI)						
CB 44	9.1	15A	561793	FR. JCT. BOX	HEADLAMP (LO)						
CB 45	9.2	10A	561792	FR. JCT. BOX	WIPER CTRL. MULTI-FUNCTION LEVEL SW.						
CB 46	9.2	20A	561794	FR. JCT. BOX	FLASHER & HAZARD UNIT						
CB 48	9.3	6A	561790	FR. JCT. BOX	STOP LTS PRESSURE SW.						
CB 49	9.3	15A	561793	RR. JCT. BOX	STOP & CYCLOP LTS						
CB 51	10	10A	561792	FR. JCT. BOX	UPPER WIPER CTRL SW.						
CB 52	11.1	15A	561793	RR. JCT. BOX	LUGGAGE & DOOR AJAR LTS						
CB 57	11.2	8A	561791	FR. JCT. BOX	DASH LTS RHEOSTAT						
CB 58	13.1	6A	561790	FR. JCT. BOX	HVAC DASH MODULE						
CB 63	11.4	8A	561791	FR. SERVICE.CPT	110V FLUORESCENT LH						
CB 64	11.4	8A	561791	FR. SERVICE.CPT	110V FLUORESCENT RH						
CB 70	22.1	6A	561790	FR. JCT. BOX	UPPER HEATING WINDSHIELD SW.						
CB 71	13.1	10A	561792	RR. JCT. BOX	A/C & HEAT LOGIC PANEL						
CB 72	13.2	10A	561792	RR. JCT. BOX	A/C COMPRESSOR CLUTCH						
CB 73	13.2	15A	561793	RR. JCT. BOX	WATER PUMP						
CB 77	13.1	40A	870093	BAT. CPT.	CONDENSER FAN MOTOR RH						
CB 78	13.1	40A	870093	BAT. CPT.	CONDENSER FAN MOTOR LH						
CB 79	13.2	15A	561793	FR. JCT. BOX	DRIVER'S HTR FAN SPEED CTRL MODULE						
CB 85	11.2	10A	561790	FR. JCT. BOX	ENTRANCE DOOR (SEDAN) & STEP LTS						
CB 93	1.2	30A	870690	BAT. CPT.	SOUND SYSTEM 12V FEEDING						
CB 94	1.2	30A	870690	BAT. CPT.	SOUND SYSTEM 12V FEEDING						
CB 95	20.1	10A	561792	S.S. JCT. PANEL	SOUND SYSTEM AMPLI						
CB 96	20.1	10A	561792	S.S. JCT. PANEL	VIDEO SYSTEM						
CB 97	20.1	10A	561792	S.S. JCT. PANEL	SOUND SYSTEM B/U P.A. AMPLI						
CB 98	20.1	15A	561793	S.S. JCT. PANEL	SOUND SYSTEM RADIO & CD						
CB 99	20.7	15A	561793	S.S. JCT. PANEL	SEAT AUDIO SYSTEM						
CB 105	21	6A	561790	FR. JCT. BOX	E.C.U. ABS						
CB 106	21	10A	561792	FR. JCT. BOX	E.C.U. ABS						
CB 107	21	10A	561792	FR. JCT. BOX	E.C.U. ABS						
CB 124	8	6A	561790	RR. JCT. BOX	RADIATOR FAN CLUTCH						
CB 126	25.1	150A	560299	BAT. CPT.	WHELL CHAIR LIFT MOTOR PUMP STE.						

# CONNECTORS CODE

NO	LOCATION	TYPE	CAVITY	#PIN	#SOCKET	NO	LOCATION	TYPE	CAVITY	#PIN	#SOCKET
				HOUSING	HOUSING					HOUSING	HOUSING
C X1	FR LH UPPER WHELL CPT-ABS	WABCO	34		X	C 58	RR JCT BOX AC PANEL	DEUTSCH	24	562280	562283
C X2	FR LH UPPER WHELL CPT-ABS	WABCO	34		X	C 59	RR JCT BOX AC PANEL	AMP CPC	14	561584	561583
C X3	FR LH UPPER WHELL CPT-ABS	WABCO			X	C 60	RR JCT BOX COMPT.-LT	AMP MNL	2	561248	561247
C X4	FR LH UPPER WHELL CPT-ABS	WABCO			X	C 61	LUGGAGE COMPARTMENT LTS	AMP MNL	2	561248	561247
C S	RR JCT BOX ECU WORLD TR.	T & BET			X	C 62	LUGGAGE COMPARTMENT LTS	AMP MNL	2	561248	561247
CT	RR JCT BOX ECU WORLD TR.	T & BET			X	C 63	LUGGAGE COMPARTMENT LTS	AMP MNL	2	561248	561247
CV	RR JCT BOX ECU WORLD TR.	T & BET			X	C 64	LUGGAGE COMPARTMENT LTS	AMP MNL	2	561248	561247
CV12	RR JCT BOX-WORLD TRANS. SHIFT & RET.					C 65	LUGGAGE COMPARTMENT LTS	AMP MNL	2	561248	561247
C 1	FR JCT BOX COMPARTMENT	AMP CPC	14	561585	561584	C 66	LUGGAGE COMPARTMENT LTS	AMP MNL	2	561248	561247
C 2	FR JCT BOX COMPARTMENT	AMP CPC	16	561639	561640	C 67	LUGGAGE COMPARTMENT LTS	AMP MNL	2	561248	561247
C 3	FR JCT BOX COMPARTMENT	AMP CPC	24	561641	561643	C 68	LUGGAGE COMPARTMENT LTS	AMP MNL	2	561248	561247
C 4	FR JCT BOX COMPARTMENT	AMP CPC	37	561644	561646	C 69	RR AXLE ACC-INSIDE PVC END	PED WP	6	561568	561578
C 5	FR SERVICE COMPT.-UNDERNEATH	AMP CPC	37	561644	561646	C 70	LH CONSOLE	AMP CPC	16	561642	561643
C 6	FR SERVICE COMPT.-UNDERNEATH	AMP CPC	16	561639	561640	C 71	FR JCT BOX COMPARTMENT	AMP CPC	37	561645	561646
C 7						C 72	FR JCT BOX COMPARTMENT	AMP CPC	24	561642	561643
C 8	FR SERVICE COMPT.-UNDERNEATH	AMP CPC	24	561641	561643	C 73	DASH CENTER PANEL	AMP CPC	16	561639	561640
C 9	FR SERVICE COMPT.-UNDERNEATH	AMP CPC	24	561641	561643	C 74	FR JCT BOX COMPARTMENT	AMP CPC	37	561645	561646
C 10						C 75					
C 11	FR SERVICE COMPARTMENT	AMP CPC	37	561644	561646	C 76	LUGGAGE COMPT.-AIR RET.SENS.	AMP MNL	2	561248	561247
C 12	FR SERVICE COMPARTMENT	AMP CPC	16	561639	561640	C 77	LUGGAGE COMPT.-AIR RET.SENS.	AMP MNL	2	561248	561247
C 13	LH CONSOLE-CTR MIRROR	AMP MNL	6	561552	561515	C 78					
C 14	UNDER DASH-LH MIRROR	AMP MNL	9	561661	561662	C 79					
C 15	RR JCT BOX	AMP CPC	24	561641	561643	C 80	LUGGAGE COMPT.-AIR RET.SENS.	AMP MNL	2	561248	561247
C 16	LH CONSOLE SW-CRUISE ON OFF	EATON	10	-----	562763	C 81	PASSENGER COMPT.-AISLE LTS	AMP MNL	2	560900	560898
C 17	LH CONSOLE SW-CRUISE RESUME	EATON	10	-----	562763	C 82	ENTRANCE DOOR	MOLEX	6	562070	562069
C 18	LH CONSOLE SW-CRUISE SET	EATON	10	-----	562763	C 83	ENTRANCE DOOR-PROIMITY SW	MOLEX	4	561477	561476
C 19	LH CONSOLE DECEL SW	EATON	10	-----	562763	C 84	ENTRANCE DOOR-PRESSURE SW	PED WP	2	561566	561690
C 20	RR JCT BOX	AMP CPC	37	561644	561646	C 85	UNDER INSTRUMENT PANEL LH	AMP MTA-100 8	-----	562248	-----
C 21	RR JCT BOX	AMP CPC	24	561641	561643	C 86					
C 22						C 87	RR END ROOF	AMP CPC	9	561636	561637
C 23						C 88	RR END ROOF-CLEARANCE LTS	AMP MNL	2	560900	560898
C 24						C 89	RR END ROOF-B/U NONITOR	AMP CPC	4	561582	561581
C 25						C 90	RR JCT BOX	AMP CPC	15	561987	561986
C 26	HYD & MAN TRANSM.-NEUT. & B/U	PED WP	4	561610	561611	C 91	RR JCT BOX	AMP CPC	37	561714	561713
C 27	HYD & MAN TRANSM.-SPEED SENS.	PED WP	2	561566	561690	C 92	FR LH UPPER WHELL CPT-ABS	AMP CPC	9	561635	561637
C 28						C 93	FR LH UPPER WHELL CPT-ABS		35	-----	641094
C 29						C 94					
C 30						C 95					
C 31						C 96	FR AXLE ACCESSORIES	AMP CPC	14	561585	561585
C 32	DDEC ENGINE-ECM	PED	30	-----	561600	C 97	RR AXLE ACC-INSIDE PVC END	PED WP	6	561568	561578
C 33						C 98	FR SERVICE COMPT-EL.FT.PEDAL	PED WP	3	561782	561781
C 34						C 99	FR SERVICE COMPT LTS	AMP MNL	2	561248	561247
C 35	RR JCT BOX	AMP CPC	24	561642	561643	C 100					
C 36						C 101	FR SERVICE COMPT-ELEC. HORNS	PED WP	2	561566	561690
C 37	RR SECTION-LH HAT RACK	MOLEX	6	562507	562503	C 102	FR SERV & SIDE CPT-FLASH. LH	GROTE	2	-----	562155
C 38	RR SECTION-RH HAT RACK	MOLEX	6	562507	562503	C 103	FR SERV & SIDE CPT-MARKERS	GROTE	2	-----	562155
C 39						C 104	FR SERV & SIDE CPT-FLASH. RH	GROTE	2	-----	562155
C 40						C 105	FR SERVICE COMPT-LIQ.S.VALVE	PED WP	2	561566	561690
C 41	LAVATORY ROOF FLUORESCENT	AMP MNL	2	560900	560898	C 106	FR SERVICE COMPT-WATER VALVE	PED WP	2	561566	561690
C 42	LAVATORY BACK WALL-WTR TANK	AMP MNL	2	560900	560898	C 107	EVAPORATOR COMPT-DAMPER	PED WP	2	561566	561690
C 43	LAVATORY BACK WALL-ACCES.	AMP MNL	9	561661	561662	C 108	FR SERVICE COMPT-KNEEL.SYS	PED WP	2	561566	561690
C 44						C 109	FR SERVICE COMPT-KNEEL.SYS	PED WP	2	561566	561690
C 45	FR JCT BOX COMPARTMENT	AMP CPC	24	561642	561643	C 110	FR SERVICE COMPT-KNEEL.SYS	PED WP	2	561566	561690
C 46						C 111	EVAPORATOR COMPT-DAMPER	DEUTSCH	2	562486	562485
C 47	FR SERVICE COMPARTMENT	AMP CPC	16	561694	561695	C 112	EVAPORATOR COMPT-SPEED MOT CTRL	DEUTSCH	5	-----	562566
C 48						C 113	BATT. & RR J.B.CPT.MARKER LT	GROTE	2	-----	562155
C 49	BATTERIE COMPT.-LT	AMP MNL	2	561248	561247	C 114	RR J. BOX CPT DOOR DIR LT LH	GROTE	2	-----	562155
C 50	FR SERVICE COMPT.-LOW BUOY	PED WP	1	561605	561577	C 115	ENGINE COMPT-AIR DRYER	PED WP	2	561566	561690
C 51						C 116	ENGINE COMPT. LTS	PED WP	1	561605	561577
C 52	RR JCT BOX	AMP CPC	22	561709	561710	C 117					
C 53						C 118	ENGINE COMPT-LAVATORY FAN	PED WP	2	561566	561690
C 54						C 119	ENGINE CPT RR DOOR RH LO LAMP	PED WP	6	561606	561607
C 55	RH SWITCH PANEL	AMP CPC	9	561636	561637	C 120	ENGINE CPT RR DOOR LH LO LAMP	PED WP	6	561606	561607
C 56											
C 57											

# CONNECTORS CODE

NO	LOCATION	TYPE	CAVITY	#PIN	#SOCKET	NO	LOCATION	TYPE	CAVITY	#PIN	#SOCKET
				HOUSING	HOUSING					HOUSING	HOUSING
C 121	BATTERIE CPT. DOOR DIR LT RH	GROTE	2	-----	562155	C 185					
C 122	ENGINE CPT-UNLOAD TAG SYSTEM	PED WP	2	561566	561690	C 186	RR JCT BOX CPT.-SPEED SIGN.TR	PED WP	2	561566	561690
C 123	TAG AXLE-UNLOAD TAG RH VALVE	PED WP	2	561566	561690	C 186M	RR JCT BOX CPT.-SPD SIGN. M.TR	PED WP	2	561566	561690
C 124	ENGINE CPT-ETHER SW	PED WP	2	561566	561690	C 186W	RR JCT BOX CPT.-SPD SIGN. WT	PED WP	2	561566	561690
C 125	ENGINE CPT-B/U ALARM	PED WP	2	561566	561690	C 187	FR JCT BOX-RPM RESISTOR CON.	AMP MNL	6	561552	561515
C 126	ENGINE CPT-FLUSHING PUMP	PED WP	2	561566	561690	C 188					
C 127	ENGINE CPT-FUEL FILTER	PED WP	2	561566	561690	C 189	ENGINE CPT RR DOOR B/U LT	PED WP	2	561566	561690
C 128	ENGINE CPT-A/C COMPR.CLUTCH	ITT SS	2	561813	561812	C 190	ENGINE CPT RR DOOR TAIL LT	PED WP	2	561566	561690
C 129	ENGINE CPT-PRE-HEAT WATER	AMP FF	6	561672	561186	C 191	ENGINE CPT RR DOOR RH STOP LT	PED WP	2	561566	561690
C 130	ENGINE CPT-UNLOADER	ITT SS	2	561813	561812	C 192	ENGINE CPT RR DOOR RH DIR. LT	PED WP	2	561566	561690
C 131	ENGINE CPT-UNLOADER	ITT SS	2	561813	561812	C 193					
C 132	ENGINE CPT-A/C LO PRESS SW	PED WP	2	561566	561690	C 194	ENGINE CPT RR DOOR LH DIR. LT	PED WP	2	561566	561690
C 133	ENGINE CPT-A/C HI PRESS SW	PED WP	2	561566	561690	C 195	ENGINE CPT RR DOOR LH STOP LT	PED WP	2	561566	561690
C 134	FR JCT BOX-LUGGAGE DIODE CON.	AMP MNL	15	561987	561986	C 196	ENGINE CPT RR DOOR CYCLOP LT	PED WP	2	561566	561690
C 135	FR JCT BOX-LUGGAGE DIODE CON.	AMP MNL	15	561987	561986	C 199	ENGINE CPT RR DOOR LICENCE LT	DOM AUTO	2	930210	-----
C 136						C 200	RH HAT RACK-FLUORESCENT	AMP MNL	2	561248	561247
C 137	RR JCT BOX-TRANSMITTER	AMP MNL	2	560900	560898	C 201	RH HAT RACK-FLUORESCENT	AMP MNL	2	561248	561247
C 138	RR JCT BOX-CONTROL MODULE	AMP HDP	15	-----	562012	C 202	RH HAT RACK-INDIRECT LIGHTING	MOLEX	2	-----	562758
C 139	RR JCT BOX-LOGIC MODULE	AMP HDP	15	562011	-----	C 203	RH HAT RACK-INDIRECT LIGHTING	MOLEX	6	-----	562759
C 140	HVAC DASH MODULE THERMOMETER	MOLEX	4			C 204	RH HAT RACK-GENERAL LT	AMP MNL	2	560900	560898
C 141	INSTRUMENT PANEL LH UNLOAD TAG	AMP	2	561248	561247	C 205	FR SECT.-RH HAT RACK SPEAKER	AMP MNL	9	561661	561662
C 142	LAVATORY DOOR WALL	AMP MNL	2	561248	561247	C 206	RH HAT RACK-READING LT	AMP FF	4	-----	562756
C 143	LAVATORY DOOR WALL	AMP MNL	3	560908	562006	C 207	LH HAT RACK-READING LT	AMP FF	4	-----	562756
C 144	UNDER LH SEAT-AISLE LTS	AMP MNL	4	560851	560852	C 208	LH HAT RACK-BALLAST	MOLEX	2	-----	562758
C 145	RR JCT BOX CPT-RR SIDE LTS	AMP MNL	9	561670	561669	C 209					
C 146	ENGINE CPT-MODULATOR VALVE	AMPENOL	2	-----	560412	C 210	FR SECT.-LH HAT RACK SPEAKER	AMP MNL	9	561661	561662
C 147	BATT & RR J.B.CPT-DOCK.LTS	PED WP	2	561566	561690	C 211	FR ROOF-STORE LH	AMP MNL	2	560900	560898
C 148						C 212	FR ROOF-STORE RH	AMP MNL	2	560900	560898
C 149	CONDENSER CPT-FAN MOTOR	ORDNANCE	3	562555	562001	C 213	FR ROOF-CLEARANCE LT	AMP MNL	2	560900	560898
C 150						C 214					
C 151	EVAPORATOR CPT-THERMOSTAT	ITT SS	2	561813	562159	C 215					
C 152	CONDENSER CPT-FUEL GAUGE	PED WP	4	561610	561611	C 216					
C 153	EVAPORATOR CPT-AIR AMB. SENS	AMP MNL	2	561248	561247	C 217					
C 154	EVAPORATOR CPT-FRESH AIR SENS	ITT SS	2	561813	561812	C 218					
C 155	EVAPORATOR CPT-WATER VALVE	PED WP	4	561610	561611	C 219					
C 156	EVAPOR. CPT-BYPASS WATER VAL.	PED WP	2	561566	561690	C 220	RR.JCT.BOX-FUEL PRIME PUMP	TC	1	561070	561073
C 157	EVAPORATOR CPT-WATER PUMP	PED WP	2	561566	561690	C 221					
C 158	CONDENSER CPT-A/C LO TEMP.	PED WP	2	561566	561690	C 222					
C 159	CONDENSER CPT-A/C HI TEMP.	PED WP	2	561566	561690	C 223					
C 160	FR AXLE-ABS RH SENSOR	WABCO	2	641132	-----	C 224					
C 161	FR AXLE-ABS RH VALVE	WABCO	3	-----	641098	C 225					
C 162	FR AXLE-ABS LH VALVE	WABCO	3	-----	641098	C 226					
C 163	FR AXLE-ABS LH SENSOR	WABCO	2	641132	-----	C 227					
C 164	RR AXLE-ABS LH SENSOR	DEUTSCH	2	562486	562485	C 228					
C 165	RR AXLE-ABS LH VALVE	WABCO	3	-----	641098	C 229					
C 166	RR AXLE-ABS RH VALVE	WABCO	3	-----	641098	C 230	ENG.CPT.-FUEL PRIME PUMP FEED	DEUTSCH	2	562486	562485
C 167	RR AXLE-ABS RH SENSOR	DEUTSCH	2	562486	562485	C 231	ENG.CPT.-FUEL PRIME PUMP SW.	PED WP	2	561566	561690
C 168	RR AXLE-ABS OPT ATC	PED WP	2	561566	561690	C 232	ENG.CPT.-FUEL PRIME PUMP	PED WP	2	561566	561690
C 169	RR JCT BOX-SPEED SW	AMP HDP	15	-----	562012	C 233					
C 170	FR JCT BOX-FLASHER UNIT	TC	2	-----	561940	C 234					
C 171	LH CONSOLE	AMP CPC	24			C 235					
C 172	ENGINE COMPT-WATER TANK HEAT.	PED WP	2	561566	561690	C 236					
C 173	LAV.POTABLE-WATER TANK HEAT.	AMP MNL	2	560900	560898	C 237	UNDER DASH LH-JACOB CLUTCH SW	ITT SS	3	561111	561080
C 174	UNDER DASH RH-HTR FAN	AMP MNL	9	561670	561669	C 238	RR JCT BOX-DIODE CONNECTOR	AMP MNL	9	561670	561669
C 175	UNDER DASH RH-HTR MODULE	AMP MNL	9	561670	561669	C 239	FR SERVICE CPT-HI BUOY VALVE	PED WP	2	561566	561690
C 176	UNDER DASH RH-WIPER PULSE	AMP FF	6	-----	561186	C 240	FR SERVICE CPT-KNEEL PROX SW	PED WP	2	561566	561690
C 177	UNDER DASH RH-WIPER MOTOR	AMP FF	6	-----	561186	C 241					
C 178	UNDER DASH RH-LH FAN	TC	2	561030	560997	C 242	FR SERVICE CPT-MARK & DIR LT	ITT SS	3	561111	561080
C 179	UNDER DASH RH-RH FAN	TC	2	561030	560997	C 243	FR SERVICE CPT-HEADLAMPS	TC	3	-----	561071
C 180	RR JCT BOX-DIODE CONNECTOR	AMP MNL	15	561987	561986	C 244	FR SERVICE CPT-LH FOG LAMP	ITT SS	2	561813	561812
C 181	RR JCT BOX-DIODE CONNECTOR	AMP MNL	15	561987	561986	C 245	FR SERVICE CPT-RH FOG LAMP	ITT SS	2	561813	561812
C 182						C 246	FR SERVICE CPT-MARK & DIR LT	ITT SS	3	561111	561080
C 183	FR SERVICE CPT-KNEELING PAN.	PED WP	4	561610	561611	C 247					
C 184	FR SERVICE CPT-KNEELING SW	ITT SS	3	561111	561080	C 248	FR JCT BOX-WIPER PULSE GEN	AMP FF	6	-----	561108

# CONNECTORS CODE

NO	LOCATION	TYPE	CAVITY	#PIN	#SOCKET	NO	LOCATION	TYPE	CAVITY	#PIN	#SOCKET
				HOUSING	HOUSING					HOUSING	HOUSING
C 249						C 313	LH CONSOLE SW-GEN & FLUOR LTS	SWF	8	-----	561107
C 250						C 314	LH CONSOLE SW-FR DEST. SIGN	SWF	8	-----	561107
C 251	LH SW PANEL-FAST IDLE	SWF	8	-----	561107	C 315	LH CONSOLE SW-LH STORE	SWF	8	-----	561107
C 252	LH SW PANEL-SWITCH LT	SWF	2	-----	561837	C 316	LH CONSOLE SPARE SWITCH	SWF	8	-----	561107
C 253	LH SW PANEL-ETHER	SWF	8	-----	561107	C 317	LH CONSOLE SW-RH STORE	SWF	8	-----	561107
C 254	INST. PANEL RH-ENTR.DOOR SW.	TORRIX	5	-----	562110	C 318	LH CONSOLE SW-DRV WINDOW LIFT	SWF	8	-----	561107
C 255	LH SW PANEL-JACOB	SWF	8	-----	561107	C 319					
C 256						C 320	LH CONSOLE SW-DRIVER'S LTS	SWF	8	-----	561107
C 257						C 321					
C 258	LH SW PANEL-MULTI FUNC. SW	AMP FF	8	561188	-----	C 322	LH CONSOLE DRV WIND LIFT MOT	PED PO	2	-----	561848
C 259	LH SW PANEL-MULTI FUNC. SW	AMP FF	6	-----	561108	C 323	LH CONSOLE CRUISE CTR SW PAN. AMP	CPC	9	561636	561637
C 260	FR SERVICE CPT-LUG DOOR LCK	PED WP	6	561606	561607	C 324					
C 261	UNDER DASH RH-DOOR MODULE	AMP MNL	9	561670	561669	C 325	LH CONSOLE SW-KNEELING	SWF	8	-----	561107
C 262	UNDER DASH RH-DOOR MODULE	AMP MNL	4	561551	561668	C 326	LH CONSOLE SW-SPARE	SWF	8	-----	561107
C 263	UNDER DASH RH-DOOR MODULE	AMP MNL	3	561667	561550	C 327	ENGINE CONTROL	DEUTSCH	6	562583	562581
C 264	UNDER DASH RH-DOOR MODULE	AMP MNL	3	561667	561550	C 328	GALLEY-LAMP	AMP MNL	2	561248	561247
C 265	UNDER DASH RH-DOOR MODULE	AMP HDP-20	15	562011	562012	C 329	ENGINE TACHO SIGNAL	PED WP	3	561781	561789
C 266						C 330	GALLEY MICROWAVE SW LT	SWF	2	-----	561837
C 267	UNDER DASH RH	AMP CPC	24	561642	561643	C 331	GALLEY MICROWAVE SW	SWF	8	-----	561107
C 268	UNDER DASH LH-MIRROR	AMP MNL	6	561552	561515	C 332	GALLEY RH CONTAINER SW LT	SWF	2	-----	561837
C 269	UNDER DASH RH-MIRROR	AMP MNL	6	561552	561515	C 333	GALLEY RH CONTAINER SW	SWF	8	-----	561107
C 270	LH MIRROR POST	MOLEX	6	562070	562069	C 334	GALLEY LH CONTAINER SW	SWF	8	-----	561107
C 271	RH MIRROR POST	MOLEX	6	562070	562069	C 335	GALLEY LH CONTAINER SW LT	SWF	2	-----	561837
C 272	LH MIRROR	SPARTAN	6	-----	990158	C 336					
C 273	RH MIRROR	SPARTAN	6	-----	990158	C 337	INSTR PANEL LH-UP WIPER SW	SWF	8	-----	561107
C 274						C 338	INSTR PANEL LH-UP DEFROST SW	SWF	8	-----	561107
C 275	UNDER DASH RH-DOOR MODULE	AMP MNL	9	561670	561669	C 339	INSTR PANEL LH-UP WASHER SW	SWF	8	-----	561107
C 276	UNDER DASH RH-LOCK SOL.VALVE	AMP MNL	2	561248	561247	C 340	FR JCT. BOX FIRE PIEZO ALARM	AMP MNL	2	560900	560898
C 277						C 341	INSTR PANEL LH-HEAT MIRROR SW	SWF	8	-----	561107
C 278						C 342	ENGINE RR START SW	DEUTSCH	2	562586	562585
C 279	UNDER DASH CYLINDER READ SW.	AMP MNL	2	561248	561247	C 343	INSTR PANEL LH-HEADLAMP SW	SWF	8	-----	561107
C 280	LH CONSOLE-UNLOAD TAG SW.	NGR	10	-----	562763	C 344	INSTR PANEL LH-HAZARD LT SW	SWF	8	-----	561107
C 281						C 345	INSTR PANEL LH-FOG LT SW	SWF	8	-----	561107
C 282						C 346	INSTR PANEL LH-SWITCH LTS	SWF	2	-----	561837
C 283						C 347	INSTR PANEL LH-DASH LT SW	AMP MNL	2	560900	560898
C 284						C 348	INSTR PANEL CENT-RACOR MODULE	MOLEX	6	562070	562067
C 285						C 349					
C 286	RH SW PANEL-A/C & HEAT	SWF	8	-----	561107	C 350	RH CONSOLE-THERMOMETER	AMP MNL	3	561667	561550
C 287	ENGINE COMPT-LTS SW	PED WP	2	561566	561690	C 351	LH HAT RACK-FLUOR 110V	MOLEX	4	561477	561476
C 288	RH SW PANEL-FRESH AIR	SWF	8	-----	561107	C 352	RH CONSOLE-DRV TEMP SENSOR	BURNDY	4	-----	561104
C 289	RH SW PANEL-SWITCH LT	SWF	2	-----	561837	C 353	INSTR PANEL RH-DRV FAN RHEOST	AMP MNL	6	561552	561515
C 290						C 354	INSTR PANEL RH-DRV TEMP CTR	AMP MNL	6	561552	561515
C 291						C 355	INSTR PANEL RH-FR TEMP CTR	AMP MNL	3	561667	561550
C 292						C 356					
C 293						C 357	INSTR PANEL RH-WATER TEMP GA	AMP MNL	3	561667	561550
C 294						C 358	INSTR PANEL RH-FUEL LEVEL GA	AMP MNL	3	561667	561550
C 295						C 359					
C 296						C 360					
C 297	INSTRUMENT PANEL RH -LTS	AMP MNL	2	560900	560898	C 361	FR ROOF-WIPER MOTOR	AMP FF	6	-----	561186
C 298						C 362	FR ROOF-LAVATORY OCCUPIED LT	AMP MNL	2	561248	561247
C 299	LH CONSOLE SW-GALLEY	SWF	8	-----	561107	C 363	FR ROOF-WATCH YOUR STEP LT	AMP MNL	2	561248	561247
C 300						C 364	FR ROOF-DESTINATION SIGN	AMP MNL	3	561667	561550
C 301						C 365	FR ROOF-UP WINDSHIELD DEFROST	AMP MNL	3	561667	561550
C 302						C 366	RH DASH PANEL-GRN & RED LEDS	AMP MNL	3	560908	562006
C 303						C 367	ENGINE COMPT-DIF OIL T SENSOR	PED WP	2	561566	561690
C 304						C 368	FR ROOF-DEST. SIGN BALLAST	AMP MNL	3	561667	561550
C 305						C 369	FR ROOF-DEST. SIGN OPER. SW	TORRIX	5	-----	562110
C 306						C 370	FR ROOF-DEST. SIGN FLUOR.	AMP MNL	2	560900	560898
C 307						C 371	FR ROOF-DEST. SIGN FLUOR.	AMP MNL	2	560900	560898
C 308	LH CONSOLE SW-RHEOSTAT	TC	2	561030	560997	C 372	FR ROOF-DEST. SIGN SPEED SW	MOLEX	4	561477	561476
C 309	DDEC ENGINE-ECM POWER CON.	PED MP	5	-----	562345	C 373	FR ROOF-NO SMOKING LT	AMP MNL	2	561248	561247
C 310	LH CONSOLE SW-LUG. DOOR LCK	SWF	8	-----	561107	C 374	LH SWITCH PANEL	AMP MNL	6	561552	561515
C 311	LH CONSOLE SW-HOS & PAS CHIME	SWF	8	-----	561107	C 375	JUMPER CONNECTOR	DEUTSCH	2		X
C 312	LH CONSOLE SW-READING LTS	SWF	8	-----	561107	C 376					

# CONNECTORS CODE

NO	LOCATION	TYPE	CAVITY	#PIN	#SOCKET	NO	LOCATION	TYPE	CAVITY	#PIN	#SOCKET
				HOUSING	HOUSING					HOUSING	HOUSING
C 377	LH SW PANEL-STOP ENG.OVERRIDE	SWF	8	-----	561107	C 441					
C 378						C 442					
C 379						C 443					
C 380	LH CONSOLE-DDR CONNECTOR	DEUTSCH	6	562360	-----	C 444					
C 381						C 445					
C 382						C 446					
C 383						C 447					
C 384						C 448					
C 385						C 449					
C 386	LH CONSOLE-WCL POWER SYSTEM	SWF	8	-----	561107	C 450	SOUND SYS. JCT. PANEL	MOLEX	4	562507	562503
C 387	RR JCT BOX (WCL)	AMP MNL	9	561661	561662	C 451	WIRELESS MICRO-FIRST CPT BAG	MOLEX	2	562550	562549
C 388	RR JCT BOX (WCL)	AMP MNL	12	561735	561734	C 452	UNDER DASH INSTR. PANEL	MOLEX	2	562550	562549
C 389	WCL REAR DOOR	MOLEX	4	561477	561476	C 453	SOUND SYS. JCT.PANEL-VCP	PED WP	2	561566	561680
C 390	LAVATORY WALL-WCL REMOTE CTR	SWF	8	-----	561107	C 454	SOUND SYS.JCT.PAN.-FILT. VCP	PED WP	2	561566	561680
C 391	LAVATORY WALL-WCL LAMP	SWF	8	-----	561107	C 455	WIRELESS MICRO-LH HAT-RACK	CINCH	2	562554	562551
C 392	LAVATORY WALL-WCL SW. LT.	SWF	2	-----	561835	C 456	WORLD TRANSM.-RETARDER ACCUM.	PED MP	2	-----	562427
C 393	LAVATORY WALL-WCL REMOTE SYS.	AMP CPC	4	561686	561687	C 457	WORLD TRANSM.-MAIN CONNECTOR	DEUTSCH	31	562572	562536
C 394	UNDER INSTR. PANEL- B/U MONITOR	AMP MNL	4	560851	560852	C 458	WORLD TRANSM.-TURBINE SP.SENS	PED MP	2	-----	562426
C 395	DRIVER'S COMPT. - B/U MONITOR	AMP	5	-----	-----	C 459	WORLD TRANSM.-ENGINE SP.SENS.	PED MP	2	-----	562426
C 396	FR SECT. LH HAT RACK-SPEAKER	MOLEX	4	562507	562503	C 460	WORLD TRANSM.-SPEED SENSOR	ITT	2	-----	562541
C 397	ENGINE COMPT. CRADLE ACC.	DEUTSCH	40	562281	562284	C 461	WORLD TRANSM.-RETARDER TEMP.	PED MP	2	561566	561680
C 398						C 462	WORLD TRANSM.-RETARD SOL."K"	PED MP	2	-----	562426
C 399						C 463	WORLD TRANSM.-SENSOR CONN.	DEUTSCH	16	562570	562571
C 400	ENGINE COMPT. BLOCK HEATER	PED MP	3	561781	561782	C 464	RR JCT BOX-DDR CONN W.T.	DEUTSCH	12	-----	562574
C 401						C 465	LH CONSOLE-SHIFTER SELECTOR	T & BET	10	-----	562429
C 402	RR DRIVE AXLE-AIR DRYER	PED MP	2	-----	562251	C 466	FR SERVICE CPT.-RESIS. MOD.	PED WP	3	-----	562428
C 403	GALLEY FRIGO NORCOLD	AMP MNL	2	561248	561247	C 467	FR SERVICE CPT.-RESIS. MOD.	PED WP	3	-----	562428
C 404	GALLEY LAMP	AMP MNL	2	561248	561247	C 468			8		
C 405						C 469					
C 406	FR JCT BOX COMPT.-ABS	AMP MNL	2	560900	560898	C 470	FR LH UPPER WHELL CPT-SILENT 1000	AMP MNL	2	561248	561247
C 407	ENGINE COMPT. -SIGNAL	PED WP	6	561606	561607	C 471	FR LH UPPER WHELL CPT-SILENT 1000	AMP MNL	2	561248	561247
C 408	ENGINE COMPT. -SIGNAL	PED WP	6	561606	561607	C 472	FR LH UPPER WHELL CPT-SILENT 1000	PED WP	2	561566	561690
C 409	ENGINE CPT -LOW COOL. LEVEL	PED MP	2	-----	562350	C 473	FR LH UPPER WHELL CPT-SILENT 1000	AMP MNL	3	561667	561550
C 410	FR JCT BOX-DIODE CONNECTOR	AMP MNL	15	561987	561986	C 474	DRIVER CPT.-TEMP. SENSOR	AMP MNL	2	561247	561248
C 411	FR JCT BOX-DIODE CONNECTOR	AMP MNL	15	561987	561986	C 475	RR JCT BOX-SPEED SIGN CONNECTOR	AMP MNL	2	561248	561247
C 412	LH SW PANEL-MASTER SWITCH	SWF	8	-----	561107	C 475M	RR JCT BOX-SPEED SIGN MANUAL TR.	MOLEX	6	562070	562069
C 413	ENG CPT-A/C HI UNLOAD PRS SW	PED WP	2	561566	561690	C 475W	RR JCT BOX-SPEED SIGN WORLD TR.	MOLEX	6	562070	562069
C 414	RR JCT BOX	AMP MNL	9	561670	561669	C 476					
C 415	ENGINE CRADLE-FAN SIGNAL	PED WP	3	561781	561782	C 477					
C 416	ENGINE CRADLE-FAN SIGNAL	PED P-C	3	562237	-----	C 478	ELECTRONIC DESTINATION SIGN	AMP CPC	9	561636	561637
C 417	FRONT JCT BOX-DIODES	AMP MNL	15	561987	561986	C 479	HVAC MODULE				
C 418	INSTR. PANEL LH-HTR WINDSH.SW	SWF	8	-----	561107	C 480					X
C 419	FR JCT BOX-RETARDER OR JACOB	AMP MNL	3	561667	561550	C 481					X
C 420	ENGINE COMPT. WEBASTO WATER HTR	TC	2	561597	-----	C 482					X
C 421	ENGINE COMPT. WEBASTO WATER HTR	TC	1	561073	-----	C 483	FR SERVICE CPT. (NOT USED)	PED PC	2	-----	562237
C 422	ENGINE COMPT. WEBASTO WATER HTR	TC	2	561597	-----	C 384					X
C 423						C 385					X
C 424	UNDER INSTRUMENT PANEL CENTER	AMP MNL	3	561667	561550	C 386					
C 425	FR JCT BOX-DIODES	AMP MNL	15	561987	561986	C 387					
C 426	ENGINE COMPT. CLUTCH CTR FAN	PED WP	3	561781	561782	C 388					
C 427						C 389					
C 428						C 390					
C 429	FR JCT BOX COMPT.	AMP MNL	6	561552	561515	C 391					
C 430	LH CONSOLE-TIMER	AMP FF	8	561188	562363	C 392					
C 431	LH CONSOLE-PRE HEAT.	TAB AMP	1	561540	561539	C 393					
C 432	ENGINE CPT.-PROX. SW. DOOR AJAR	DEUTSCH	4	562479	562477	C 394					
C 433	FR SERVICE CPT. KNEEL. PRESS. SW	PED WP	2	561566	561690	C 395					
C 434	FRONT JCT. BOX-DIODES	AMP MNL	15	561987	561986	C 396					
C 435	FR SERVICE CPT.(RH) KNEEL. PIEZO	AMP MNL	2	560900	560898	C 397					
C 436	RH HAT RACK-WCL CENTER ROOF ACC	AMP CPC	16	561639	561640	C 398					
C 437	RH HAT RACK-WCL FR & RR SECT.	AMP CPC	24	561642	561643	C 399					
C 438						C 500	FR LH UPPER WHELL CPT -PRODRIVER	MOLEX	6	562070	562069
C 439						C 501	FR LH UPPER WHELL CPT -PRODRIVER	PED MP	7	562433	-----
C 440							MOD				



# CONNECTORS CODE

NO	LOCATION	TYPE	CAVITY	#PIN	#SOCKET	NO	LOCATION	TYPE	CAVITY	#PIN	#SOCKET
				HOUSING	HOUSING					HOUSING	HOUSING
C 502	LH CONSOLE-PRE HEATER SW.	SWF	8	-----	561107	C 568	SOUND SYS. JCT. PANEL - PASS. SPK	CINCH	4	562553	562552
C 503	LH CONSOLE-PRE HEATER SW.	SWF	2	-----	561837	C 569	SOUND SYS. JCT. PANEL - POWER AMPLI.	MOLEX	9	562556	562555
C 504	LH CONSOLE WEBASTO TIMER	AMP	8	561188	562363	C 570	UNDER DASH PANEL TTLT	MOLEX	6	56	562464
C 505	LH CONSOLE ESPAR TIMER	AMP	9	-----	562681	C 571	UNDER DASH PANEL TTLT	MOLEX	20	56	56
C 506	FR JCT BOX CPT. DIGITAL CLOCK	AMP	4	561685	561687	C 572	UNDER DASH PANEL TTLT	MOLEX	18	56	56
C 507	FR SECT. LH HAT-RACK DIG. CLOCK	MOLEX	4	561477	561476	C 573	UNDER DASH PANEL TTLT	MOLEX	16	56	562465
C 508	RR JCT BOX-FAN CLUTCH RETARDER	AMP MNL	6	561552	561515	C 574	HAT -RACK FLUOR. INDIRECT LIGHTING	MOLEX	6	-----	562759
C 509	FR LH UPPER WHELL CPT -DATA LOGGER	PED MP	16	-----	562530	C 575					
C 510	FR LH UPPER WHELL CPT -DATA LOGGER	DEUTSCH	9	562531	-----	C 576					
C 511	FR LH UPPER WHELL CPT -DATA LOGGER	PED MP	4	562532	-----	C 577					
C 512	FR LH UPPER WHELL CPT -DATA LOGGER	PED MP	10	562533	-----	C 578					
C 513	FR LH UPPER WHELL CPT -DATA LOGGER	AMP MNL	3	561667	561550	C 579					
C 514	FR LH UPPER WHELL CPT -DATA LOGGER	PED MP	6	562433	562417	C 580					
C 515	FR JCT BOX CPT.-INTERCOM	MOLEX	4	561477	561476	C 581					
C 516	FR JCT BOX CPT.-INTERCOM	MOLEX	6	562070	562069	C 582	FRONT SERVICE CMPT. - WINDOWS AJAR	PED WP	2	561566	561690
C 517	LAVATORY WALL-INTERCOM	MOLEX	6	562070	562069	C 583	L.H. DASH PANEL - MASTER KEY	DEUTSCH	2	562486	562485
C 519	UNDER DASH RH-SEDAN DOOR	HUMPHREY	2	-----	562580	C 584	FRONT SERVICE CMPT. - AIR HORH	HUMPHREY	3	-----	641385
C 520	UNDER DASH RH-SEDAN DOOR	HUMPHREY	2	-----	641385	C 585					
C 521	UNDER DASH RH-SEDAN DOOR	HUMPHREY	2	-----	641385	C 586	L.H. DASH PANEL - DISPLAY SET SW.				
C 522	FR JCT BOX-DAYTIME LTS MODULE	BOSCH	5	-----	561183	C 587					
C 523	FR JCT BOX-FUSE BLOCK	PED	8	562647	562646	C 588	FRONT SERVICE CMPT. CENTER	AMP. CPC	37	561645	561646
C 524	FR JCT BOX-FUSE BLOCK	PED	8	562647	562646	C 589	UNDER DASH - L.H. MIRROR	AMP MNL	9	561670	561669
C 525	FR JCT BOX-FUSE BLOCK	PED	8	562647	562646	C 590	UNDER DASH - R.H. MIRROR	AMP MNL	9	561670	561669
C 526	FR JCT BOX-FUSE BLOCK	PED	8	562647	562646	C 591	L.H.CONSOLE - MIRROR L.H.	EURAMTEC	8	-----	562799
C 527	FR JCT BOX-FUSE BLOCK	PED	8	562647	562646	C 592	L.H.CONSOLE - MIRROR R.H.	EURAMTEC	8	-----	562799
C 528	FR JCT BOX-FUSE BLOCK	PED	8	562647	562646	C 593	BATTERY CMPT. - CHARGER	PED WP	3	561781	561782
C 529	FR JCT BOX-12V OUTLET	AMP MNL	2	561247	561248	C 594	FRONT ROOF - DRIVERS LIGHT	LEEKRAFT	-----	-----	562803
C 530	RR JCT BOX-FUSE BLOCK	PED	8	562647	562646	C 595	DASH CENTER MODULE - OPEN DOOR	MOLEX	4	561477	561476
C 531	RR JCT BOX-FUSE BLOCK	PED	8	562647	562646	C 596	DASH CENTER MODULE - CLOSE DOOR	MOLEX	4	561477	561476
C 532	RR JCT BOX-FUSE BLOCK	PED	8	562647	562646	C 597	DASH CENTER MODULE - OPEN DOOR	MOLEX	4	561477	561476
C 533	RR JCT BOX-FUSE BLOCK	PED	8	562647	562646	C 598	DASH CENTER MODULE - OPEN DOOR	MOLEX	4	561477	561476
C 534	RR JCT BOX-FUSE BLOCK	PED	8	562647	562646	C 599	DASH CENTER MODULE - OPEN DOOR	MOLEX	4	561477	561476
C 535	RR JCT BOX-FIRE MODULE DETECT.	AMP MNL	3	561667	561550	C 600	ENGINE CMPT.-A/C LOW PRESS SW.	PED	2	562348	562471
C 536	UNDER DASH RH-DRIVER'S HTR TEMP. CTR	AMP MNL	6	561552	561515		UNLOAD				
C 537	BATT. CPT.-A/C PRESS. SIGN. RLY	AMP MNL	2	561248	561247	C 601	L.H. ROOF - WINDOW AJAR	AMP MNL	2	561248	561247
C 538	FR SERVICE CPT.-OUTSIDE TEMP. SENSOR	AMP MNL	2	561248	561247	C 602	L.H. ROOF - WINDOW AJAR	MOLEX	4	561477	561476
C 539	HVAC DASH MODULE OUTPUT CON	MOLEX	24			C 603	R.H. ROOF - WINDOW AJAR	AMP MNL	2	561248	561247
C 540	HVAC DASH MODULE INPUT CON	MOLEX	22			C 604					
C 541	SOUND SYS. JCT PANEL-AUDIO SEAT SYS.	PED WP	2	561566	561690	C 605	HAT RACK - MOTOR FAN	PED	2	560997	561030
C 542	LH HAT RACK-AUDIO SEAT SYSTEM	AMP MNL	3	561667	561550	C 606					
C 543	RR JCT BOX-PARK. BRAKE STOP LTS RESIS.	PED WP	2	561566	561690	C 607	FRONT SERVICE CMPT. RPM SIGNAL	PED WP	2	561566	561690
C 544	SOUND SYS JCT PANEL-AUDIO SEAT SYS.	PED WP	3	561781	562428	C 608	FRONT SERVICE CMPT. SPEED SIGNAL	PED WP	2	561566	561690
C 545	LH HAT RACK-AUDIO SEAT SYSTEM	AMP MNL	3	561667	561550	C 609	LAVATORY - NIGHT LIGHT				
C 546						C 610	RR JCT BOX	CPC	6	561552	561515
C 547	RH DASH PANEL-ACCESSORIES	AMP CPC	37	561645	561646	C 611					
C 548	LH DASH PANEL-T.T. LT. TEST SW.	SWF	8	-----	561107	C 612					
C 549	LH CONSOLE-FAN CLUTCH OVERRIDE SW.	SWF	8	-----	561107	C 613					
C 550	LAST LUGG. CPT. -WCL RICON	AMP CPC	16	561694	561695	C 614					
C 551	LAST LUGG. CPT. -WCL RICON	AMP CPC	16	561694	561695	C 615					
C 552	LAST LUGG. CPT. -WCL RICON	AMP CPC	9	561636	561637	C 616					
C 553	UNDER DASH R.H. - CONTROL. HEAD	MOLEX	16	-----	562559	C 617					
C 554	UNDER DASH R.H. - CONTROL. HEAD	MOLEX	16	-----	562559	C 618					
C 555	UNDER DASH R.H. - CONTROL. HEAD	MOLEX	16	-----	562559	C 619					
C 556	UNDER DASH R.H. - RADIO ACC.	MOLEX	2	562550	562549						
C 557	UNDER DASH R.H. - RADIO ACC.	MOLEX	9	562556	562555						
C 558	UNDER DASH R.H. - RADIO ACC.	MOLEX	4	562507	562503						
C 559	L.H. HAT RACK - PASSENGER SPK.	MOLEX	4	562507	562503						
C 560	SOUND SYS. JCT. PANEL - POWER AMPLI	MOLEX	4	562507	562503						
C 561	L.H. HAT RACK - WIRELESS MICRO	MOLEX	4	562507	562503						
C 562	L.H. HAT RACK - VCP	MOLEX	9	562556	562555						
C 563	L.H MODESTY PANEL - DRIVERS SPK.	MOLEX	4	562507	562503						
C 564	L.H MODESTY PANEL - MICRO	MOLEX	4	562507	562503						
C 565	R.H MODESTY PANEL - MICRO	MOLEX	4	562507	562503						
C 566	L.H. CONSOLE - BOOM MICRO	MOLEX	4	562507	562503						
C 567	L.H. CONSOLE - DRIVERS MICRO	MOLEX	4	562507	562503						

# CONNECTORS CODE

NO	LOCATION	TYPE	CAVITY	#PIN	#SOCKET	NO	LOCATION	TYPE	CAVITY	#PIN	#SOCKET
				HOUSING	HOUSING					HOUSING	HOUSING
C X1	FR LH UPPER WHELL CPT-ABS	WABCO	18		562792	C 57					
C X2	FR LH UPPER WHELL CPT-ABS	WABCO	6		562793	C 58	RR JCT BOX AC PANEL	DEUTSCH	24	562280	562283
C X3	FR LH UPPER WHELL CPT-ABS	WABCO	9		562794	C 59	RR JCT BOX AC PANEL	AMP CPC	14	561584	561583
C X4	FR LH UPPER WHELL CPT-ABS	WABCO	15		562795	C 60	RR JCT BOX COMPT.-LT	AMP MNL	2	561248	561247
C S	RR JCT BOX ECU WORLD TR.	PED	32		562817	C 61	LUGGAGE COMPARTMENT LTS	AMP MNL	2	561248	561247
CT	RR JCT BOX ECU WORLD TR.	PED	32		562824	C 62	LUGGAGE COMPARTMENT LTS	AMP MNL	2	561248	561247
CV	RR JCT BOX ECU WORLD TR.	PED	32		562823	C 63	LUGGAGE COMPARTMENT LTS	AMP MNL	2	561248	561247
CV12	RR JCT BOX-WORLD TRANS. SHIFT & RET. CLUSTER	AMP CPC	9	561636	561637	C 64	LUGGAGE COMPARTMENT LTS	AMP MNL	2	561248	561247
C Y		JAE	30		562765	C 65	LUGGAGE COMPARTMENT LTS	AMP MNL	2	561248	561247
C 1	FR JCT BOX COMPARTMENT	AMP CPC	14	561585	561584	C 66	LUGGAGE COMPARTMENT LTS	AMP MNL	2	561248	561247
C 2	FR JCT BOX COMPARTMENT	AMP CPC	16	561639	561640	C 67	LUGGAGE COMPARTMENT LTS	AMP MNL	2	561248	561247
C 3	FR JCT BOX COMPARTMENT	AMP CPC	24	561641	561643	C 68	LUGGAGE COMPARTMENT LTS	AMP MNL	2	561248	561247
C 4	FR JCT BOX COMPARTMENT	AMP CPC	37	561644	561646	C 69	RR AXLE ACC-INSIDE PVC END	PED WP	6	561568	561578
C 5	FR SERVICE COMPT.-UNDERNEATH	AMP CPC	37	561644	561646	C 70	LH CONSOLE	AMP CPC	16	561642	561643
C 6	FR SERVICE COMPT.-UNDERNEATH	AMP CPC	16	561639	561640	C 71	FR JCT BOX COMPARTMENT	AMP CPC	37	561645	561646
C 7						C 72	FR JCT BOX COMPARTMENT	AMP CPC	24	561642	561643
C 8	FR SERVICE COMPT.-UNDERNEATH	AMP CPC	24	561641	561643	C 73	DASH CENTER PANEL	AMP CPC	16	561639	561640
C 9	FR SERVICE COMPT.-UNDERNEATH	AMP CPC	24	561641	561643	C 74	FR JCT BOX COMPARTMENT	AMP CPC	37	561645	561646
C 10						C 75					
C 11	FR SERVICE COMPARTMENT	AMP CPC	37	561644	561646	C 76	LUGGAGE COMPT.-AIR RET.SENS.	AMP MNL	2	561248	561247
C 12	FR SERVICE COMPARTMENT	AMP CPC	16	561639	561640	C 77	LUGGAGE COMPT.-AIR RET.SENS.	AMP MNL	2	561248	561247
C 13	LH CONSOLE-CTR MIRROR	AMP MNL	6	561552	561515	C 78					
C 14	UNDER DASH-LH MIRROR	AMP MNL	9	561661	561662	C 79					
C 15	RR JCT BOX	AMP CPC	24	561641	561643	C 80	LUGGAGE COMPT.-AIR RET.SENS.	AMP MNL	2	561248	561247
C 16	LH CONSOLE SW-CRUISE ON OFF	EATON	10	-----	562763	C 81	PASSENGER COMPT.-AISLE LTS	AMP MNL	2	560900	560898
C 17	LH CONSOLE SW-CRUISE RESUME	EATON	10	-----	562763	C 82	ENTRANCE DOOR	MOLEX	6	562070	562069
C 18	LH CONSOLE SW-CRUISE SET	EATON	10	-----	562763	C 83	ENTRANCE DOOR-PROIMITY SW	MOLEX	4	561477	561476
C 19	LH CONSOLE DECEL SW	EATON	10	-----	562763	C 84	ENTRANCE DOOR-PRESSURE SW	PED WP	2	561566	561690
C 20	RR JCT BOX	AMP CPC	37	561644	561646	C 85	UNDER INSTRUMENT PANEL LH	AMP MTA-100	8	562248	-----
C 21	RR JCT BOX	AMP CPC	24	561641	561643	C 86					
C 22						C 87	RR END ROOF	AMP CPC	9	561636	561637
C 23						C 88	RR END ROOF-CLEARANCE LTS	AMP MNL	2	560900	560898
C 24						C 89	RR END ROOF-B/U NONITOR	AMP CPC	4	561582	561581
C 25						C 90	RR JCT BOX	AMP CPC	15	561987	561986
C 26	HYD & MAN TRANSM.-NEUT. & B/U	PED WP	4	561610	561611	C 91	RR JCT BOX	AMP CPC	37	561714	561713
C 27	HYD & MAN TRANSM.-SPEED SENS.	PED WP	2	561566	561690	C 92	FR LH UPPER WHELL CPT-ABS	AMP CPC	9	561635	561637
C 28						C 93	FR LH UPPER WHELL CPT-ABS		35	-----	641094
C 29						C 94					
C 30						C 95					
C 31						C 96	FR AXLE ACCESSORIES	AMP CPC	14	561585	561585
C 32	DDEC ENGINE-ECM	PED	30	-----	561600	C 97	RR AXLE ACC-INSIDE PVC END	PED WP	6	561568	561578
C 33						C 98	FR SERVICE COMPT-EL.DIR.LT.PEDAL	PED WP	3	561782	561781
C 34						C 99	FR SERVICE COMPT LTS	AMP MNL	2	561248	561247
C 35	RR JCT BOX	AMP CPC	24	561642	561643	C 100					
C 36						C 101	FR SERVICE COMPT-ELEC. HORNS	PED WP	2	561566	561690
C 37	RR SECTION-LH HAT RACK	MOLEX	6	562507	562503	C 102	FR SERV & SIDE CPT-FLASH. LH	GROTE	2	-----	562155
C 38	RR SECTION-RH HAT RACK	MOLEX	6	562507	562503	C 103	FR SERV & SIDE CPT-MARKERS	GROTE	2	-----	562155
C 39						C 104	FR SERV & SIDE CPT-FLASH. RH	GROTE	2	-----	562155
C 40						C 105	FR SERVICE COMPT-LIQ.S.VALVE	PED WP	2	561566	561690
C 41	LAVATORY ROOF FLUORESCENT	AMP MNL	2	560900	560898	C 106	FR SERVICE COMPT-WATER VALVE	PED WP	2	561566	561690
C 42	LAVATORY BACK WALL-WTR TANK	AMP MNL	2	560900	560898	C 107	EVAPORATOR COMPT-DAMPER	PED WP	2	561566	561690
C 43	LAVATORY BACK WALL-ACCES.	AMP MNL	9	561661	561662	C 108	FR SERVICE COMPT-KNEEL.SYS	PED WP	2	561566	561690
C 44						C 109	FR SERVICE COMPT-KNEEL.SYS	PED WP	2	561566	561690
C 45	FR JCT BOX COMPARTMENT	AMP CPC	24	561642	561643	C 110	FR SERVICE COMPT-KNEEL.SYS	PED WP	2	561566	561690
C 46						C 111	EVAPORATOR COMPT-DAMPER	DEUTSCH	2	562486	562485
C 47	FR SERVICE COMPARTMENT	AMP CPC	16	561694	561695	C 112	EVAPORATOR COMPT-SPEED MOT CTRL	DEUTSCH	5	-----	562566
C 48						C 113	BATT. & RR J.B.CPT.MARKER LT	GROTE	2	-----	562155
C 49	BATTERIE COMPT.-LT	AMP MNL	2	561248	561247	C 114	RR J. BOX CPT DOOR DIR LT LH	GROTE	2	-----	562155
C 50	FR SERVICE COMPT.-LOW BUOY	PED WP	1	561605	561577	C 115	ENGINE COMPT-AIR DRYER	PED WP	2	561566	561690
C 51						C 116	ENGINE COMPT. LTS	PED WP	1	561605	561577
C 52	RR JCT BOX	AMP CPC	22	561709	561710	C 117					
C 53						C 118	ENGINE COMPT-LAVATORY FAN	PED WP	2	561566	561690
C 54						C 119	ENGINE CPT RR DOOR RH LO LAMP	PED WP	6	561606	561607
C 55	RH SWITCH PANEL	AMP CPC	9	561636	561637						
C 56											



# CONNECTORS CODE

NO	LOCATION	TYPE	CAVITY	#PIN	#SOCKET	NO	LOCATION	TYPE	CAVITY	#PIN	#SOCKET
				HOUSING	HOUSING					HOUSING	HOUSING
C 120	ENGINE CPT RR DOOR LH LO LAMP	PED WP	6	561606	561607	C 184	FR SERVICE CPT-KNEELING SW	ITT SS	3	561111	561080
C 121	BATTERIE CPT. DOOR DIR LT RH	GROTE	2	-----	562155	C 185					
C 122	ENGINE CPT-UNLOAD TAG SYSTEM	PED WP	2	561566	561690	C 186	RR JCT BOX CPT.-SPEED SIGN.TR	PED WP	2	561566	561690
C 123	TAG AXLE-UNLOAD TAG RH VALVE	PED WP	2	561566	561690	C 186M	RR JCT BOX CPT.-SPD SIGN. M.TR	PED WP	2	561566	561690
C 124	ENGINE CPT-ETHER SW	PED WP	2	561566	561690	C 186W	RR JCT BOX CPT.-SPD SIGN. WT	PED WP	2	561566	561690
C 125	ENGINE CPT-B/U ALARM	PED WP	2	561566	561690	C 187	FR JCT BOX-RPM RESISTOR CON.	AMP MNL	6	561552	561515
C 126	ENGINE CPT-FLUSHING PUMP	PED WP	2	561566	561690	C 188					
C 127	ENGINE CPT-FUEL FILTER	PED WP	2	561566	561690	C 189	ENGINE CPT RR DOOR B/U LT	PED WP	2	561566	561690
C 128	ENGINE CPT-A/C COMPR.CLUTCH	ITT SS	2	561813	561812	C 190	ENGINE CPT RR DOOR TAIL LT	PED WP	2	561566	561690
C 129	ENGINE CPT-PRE-HEAT WATER	AMP FF	6	561672	561186	C 191	ENGINE CPT RR DOOR RH STOP LT	PED WP	2	561566	561690
C 130	ENGINE CPT-UNLOADER	ITT SS	2	561813	561812	C 192	ENGINE CPT RR DOOR RH DIR. LT	PED WP	2	561566	561690
C 131	ENGINE CPT-UNLOADER	ITT SS	2	561813	561812	C 193					
C 132	ENGINE CPT-A/C LO PRESS SW	PED WP	2	561566	561690	C 194	ENGINE CPT RR DOOR LH DIR. LT	PED WP	2	561566	561690
C 133	ENGINE CPT-A/C HI PRESS SW	PED WP	2	561566	561690	C 195	ENGINE CPT RR DOOR LH STOP LT	PED WP	2	561566	561690
C 134	FR JCT BOX-LUGGAGE DIODE CON.	AMP MNL	15	561987	561986	C 196	ENGINE CPT RR DOOR CYCLOP LT	PED WP	2	561566	561690
C 135	FR JCT BOX-LUGGAGE DIODE CON.	AMP MNL	15	561987	561986	C 199	ENGINE CPT RR DOOR LICENCE LT	DOM AUTO	2	930210	-----
C 136						C 200	RH HAT RACK-FLUORESCENT	AMP MNL	2	561248	561247
C 137	RR JCT BOX-TRANSMITTER	AMP MNL	2	560900	560898	C 201	RH HAT RACK-FLUORESCENT	AMP MNL	2	561248	561247
C 138	RR JCT BOX-CONTROL MODULE	AMP HDP	15	-----	562012	C 202	RH HAT RACK-INDIRECT LIGHTING	MOLEX	2	-----	562758
C 139	RR JCT BOX-LOGIC MODULE	AMP HDP	15	562011	-----	C 203	RH HAT RACK-INDIRECT LIGHTING	MOLEX	6	-----	562759
C 140	HVAC DASH MODULE THERMOMETER	MOLEX	4		562782	C 204	RH HAT RACK-GENERAL LT	AMP MNL	2	560900	560898
C 141	INSTRUMENT PANEL LH UNLOAD TAG	AMP	2	561248	561247	C 205	FR SECT.-RH HAT RACK SPEAKER	AMP MNL	9	561661	561662
C 142	LAVATORY DOOR WALL	AMP MNL	2	561248	561247	C 206	RH HAT RACK-READING LT	AMP FF	4	-----	562756
C 143	LAVATORY DOOR WALL	AMP MNL	3	560908	562006	C 207	LH HAT RACK-READING LT	AMP FF	4	-----	562756
C 144	UNDER LH SEAT-AISLE LTS	AMP MNL	4	560851	560852	C 208	LH HAT RACK-BALLAST	MOLEX	2	-----	562758
C 145	RR JCT BOX CPT-RR SIDE LTS	AMP MNL	9	561670	561669	C 209	LH HAT RACK HOTESS CHIME	AMP MNL	3	561667	561550
C 146	ENGINE CPT-MODULATOR VALVE	AMPHENOL	2	-----	560412	C 210	FR SECT.-LH HAT RACK SPEAKER	AMP MNL	9	561661	561662
C 147	BATT & RR J.B.CPT-DOCK.LTS	PED WP	2	561566	561690	C 211	FR ROOF-STORE LH	AMP MNL	2	560900	560898
C 148						C 212	FR ROOF-STORE RH	AMP MNL	2	560900	560898
C 149	CONDENSER CPT-FAN MOTOR	ORDNANCE	3	562555	562001	C 213	FR ROOF-CLEARANCE LT	AMP MNL	2	560900	560898
C 150						C 214					
C 151	EVAPORATOR CPT-THERMOSTAT	ITT SS	2	561813	562159	C 215					
C 152	CONDENSER CPT-FUEL GAUGE	PED WP	4	561610	561611	C 216					
C 153	EVAPORATOR CPT-AIR AMB. SENS	AMP MNL	2	561248	561247	C 217					
C 154	EVAPORATOR CPT-FRESH AIR SENS	ITT SS	2	561813	561812	C 218					
C 155	EVAPORATOR CPT-WATER VALVE	PED WP	4	561610	561611	C 219					
C 156	EVAPOR. CPT-BYPASS WATER VAL.	PED WP	2	561566	561690	C 220	RR.JCT.BOX-FUEL PRIME PUMP	TC	1	561070	561073
C 157	EVAPORATOR CPT-WATER PUMP	PED WP	2	561566	561690	C 221					
C 158	CONDENSER CPT-A/C LO TEMP.	PED WP	2	561566	561690	C 222					
C 159	CONDENSER CPT-A/C HI TEMP.	PED WP	2	561566	561690	C 223					
C 160	FR AXLE-ABS RH SENSOR	WABCO	2	641132	-----	C 224					
C 161	FR AXLE-ABS RH VALVE	WABCO	3	-----	641098	C 225					
C 162	FR AXLE-ABS LH VALVE	WABCO	3	-----	641098	C 226					
C 163	FR AXLE-ABS LH SENSOR	WABCO	2	641132	-----	C 227					
C 164	RR AXLE-ABS LH SENSOR	DEUTSCH	2	562486	562485	C 228					
C 165	RR AXLE-ABS LH VALVE	WABCO	3	-----	641098	C 229					
C 166	RR AXLE-ABS RH VALVE	WABCO	3	-----	641098	C 230	ENG.CPT.-FUEL PRIME PUMP FEED	DEUTSCH	2	562486	562485
C 167	RR AXLE-ABS RH SENSOR	DEUTSCH	2	562486	562485	C 231	ENG.CPT.-FUEL PRIME PUMP SW.	PED WP	2	561566	561690
C 168	RR AXLE-ABS OPT ATC	PED WP	2	561566	561690	C 232	ENG.CPT.-FUEL PRIME PUMP	PED WP	2	561566	561690
C 169	RR JCT BOX-SPEED SW	AMP HDP	15	-----	562012	C 233	FR. SERVICE COMPT.	VDO	8		562043
C 170	FR JCT BOX-FLASHER UNIT	TC	2	-----	561940	C 234	FR. SERVICE COMPT.	VDO	8		562044
C 171	LH CONSOLE	AMP CPC	24	561642	561643	C 235	FR. SERVICE COMPT.	VDO	8		562041
C 172	ENGINE COMPT-WATER TANK HEAT.	PED WP	2	561566	561690	C 236	LUGGAGE COMPARTMENT	AMP MNL	4	560851	560852
C 173	LAV.POTABLE-WATER TANK HEAT.	AMP MNL	2	560900	560898	C 237	UNDER DASH LH-JACOB CLUTCH SW	ITT SS	3	561111	561080
C 174	UNDER DASH RH-HTR MODULE	AMP MNL	9	561670	561669	C 238	RR JCT BOX-DIODE CONNECTOR	AMP MNL	9	561670	561669
C 175	UNDER DASH RH-HTR MODULE	AMP MNL	9	561670	561669	C 239	FR SERVICE CPT-HI BUOY VALVE	PED WP	2	561566	561690
C 176	UNDER DASH RH-WIPER PULSE	AMP FF	6	-----	561186	C 240	FR SERVICE CPT-KNEEL PROX SW	PED WP	2	561566	561690
C 177	UNDER DASH RH-WIPER MOTOR	AMP FF	6	-----	561186	C 241					
C 178	UNDER DASH RH-LH FAN	TC	2	561030	560997	C 242	FR SERVICE CPT-MARK & DIR LT	ITT SS	3	561111	561080
C 179	UNDER DASH RH-RH FAN	TC	2	561030	560997	C 243	FR SERVICE CPT-HEADLAMPS	TC	3	-----	561071
C 180	RR JCT BOX-DIODE CONNECTOR	AMP MNL	15	561987	561986	C 244	FR SERVICE CPT-LH FOG LAMP	ITT SS	2	561813	561812
C 181	RR JCT BOX-DIODE CONNECTOR	AMP MNL	15	561987	561986	C 245	FR SERVICE CPT-RH FOG LAMP	ITT SS	2	561813	561812
C 182						C 246	FR SERVICE CPT-MARK & DIR LT	ITT SS	3	561111	561080
C 183	FR SERVICE CPT-KNEELING PAN.	PED WP	4	561610	561611	C 247					

# CONNECTORS CODE

NO	LOCATION	TYPE	CAVITY	#PIN	#SOCKET	NO	LOCATION	TYPE	CAVITY	#PIN	#SOCKET
				HOUSING	HOUSING					HOUSING	HOUSING
C 248	FR JCT BOX-WIPER PULSE GEN	AMP FF	6	-----	561108	C 312	LH CONSOLE SW-READING LTS	SWF	8	-----	561107
C 249						C 313	LH CONSOLE SW-GEN & FLUOR LTS	SWF	8	-----	561107
C 250						C 314	LH CONSOLE SW-FR DEST. SIGN	SWF	8	-----	561107
C 251	LH SW PANEL-FAST IDLE	SWF	8	-----	561107	C 315	LH CONSOLE SW-LH STORE	SWF	8	-----	561107
C 252	LH SW PANEL-SWITCH LT	SWF	2	-----	561837	C 316	LH CONSOLE SPARE SWITCH	SWF	8	-----	561107
C 253	LH SW PANEL-ETHER	SWF	8	-----	561107	C 317	LH CONSOLE SW-RH STORE	SWF	8	-----	561107
C 254	INST. PANEL RH-ENTR.DOOR SW.	TORRIX	5	-----	562110	C 318	LH CONSOLE SW-DRV WINDOW LIFT	SWF	8	-----	561107
C 255	LH SW PANEL-JACOB	SWF	8	-----	561107	C 319					
C 256						C 320	LH CONSOLE SW-DRIVER'S LTS	SWF	8	-----	561107
C 257						C 321					
C 258	LH SW PANEL-MULTI FUNC. SW	AMP FF	8	561188	-----	C 322	LH CONSOLE DRV WIND LIFT MOT	PED PO	2	-----	561848
C 259	LH SW PANEL-MULTI FUNC. SW	AMP FF	6	-----	561108	C 323	LH CONSOLE CRUISE CTR SW PAN. AMP	CPC	9	561636	561637
C 260	FR SERVICE CPT-LUG DOOR LCK	PED WP	6	561606	561607	C 324					
C 261	UNDER DASH RH-DOOR MODULE	AMP MNL	9	561670	561669	C 325	LH CONSOLE SW-KNEELING	SWF	8	-----	561107
C 262	UNDER DASH RH-DOOR MODULE	AMP MNL	4	561551	561668	C 326	LH CONSOLE SW-SPARE	SWF	8	-----	561107
C 263	UNDER DASH RH-DOOR MODULE	AMP MNL	3	561667	561550	C 327	ENGINE CONTROL	DEUTSCH	6	562583	562581
C 264	UNDER DASH RH-DOOR MODULE	AMP MNL	3	561667	561550	C 328	GALLEY-LAMP	AMP MNL	2	561248	561247
C 265	UNDER DASH RH-DOOR MODULE	AMP HDP-20	15	562011	562012	C 329	ENGINE TACHO SIGNAL	PED WP	3	561781	561789
C 266						C 330	GALLEY MICROWAVE SW LT	SWF	2	-----	561837
C 267	UNDER DASH RH	AMP CPC	24	561642	561643	C 331	GALLEY MICROWAVE SW	SWF	8	-----	561107
C 268	UNDER DASH LH-MIRROR	AMP MNL	6	561552	561515	C 332	GALLEY RH CONTAINER SW LT	SWF	2	-----	561837
C 269	UNDER DASH RH-MIRROR	AMP MNL	6	561552	561515	C 333	GALLEY RH CONTAINER SW	SWF	8	-----	561107
C 270	LH MIRROR POST	MOLEX	6	562070	562069	C 334	GALLEY LH CONTAINER SW	SWF	8	-----	561107
C 271	RH MIRROR POST	MOLEX	6	562070	562069	C 335	GALLEY LH CONTAINER SW LT	SWF	2	-----	561837
C 272	LH MIRROR	SPARTAN	6	-----	990158	C 336					
C 273	RH MIRROR	SPARTAN	6	-----	990158	C 337	INSTR PANEL LH-UP WIPER SW	SWF	8	-----	561107
C 274						C 338	INSTR PANEL LH-UP DEFROST SW	SWF	8	-----	561107
C 275	UNDER DASH RH-DOOR MODULE	AMP MNL	9	561670	561669	C 339	INSTR PANEL LH-UP WASHER SW	SWF	8	-----	561107
C 276	UNDER DASH RH-LOCK SOL.VALVE	AMP MNL	2	561248	561247	C 340	FR JCT. BOX FIRE PIEZO ALARM	AMP MNL	2	560900	560898
C 277						C 341	INSTR PANEL LH-HEAT MIRROR SW	SWF	8	-----	561107
C 278						C 342	ENGINE RR START SW	DEUTSCH	2	562586	562585
C 279	UNDER DASH CYLINDER READ SW.	AMP MNL	2	561248	561247	C 343	INSTR PANEL LH-HEADLAMP SW	SWF	8	-----	561107
C 280	LH CONSOLE-UNLOAD TAG SW.	NGR	10	-----	562763	C 344	INSTR PANEL LH-HAZARD LT SW	SWF	8	-----	561107
C 281						C 345	INSTR PANEL LH-FOG LT SW	SWF	8	-----	561107
C 282						C 346	INSTR PANEL LH-SWITCH LTS	SWF	2	-----	561837
C 283						C 347	INSTR PANEL LH-DASH LT SW	AMP MNL	2	560900	560898
C 284						C 348	INSTR PANEL CENT-RACOR MODULE	MOLEX	6	562070	562067
C 285						C 349					
C 286	RH SW PANEL-A/C & HEAT	SWF	8	-----	561107	C 350	RH CONSOLE-THERMOMETER	AMP MNL	3	561667	561550
C 287	ENGINE COMPT-LTS SW	PED WP	2	561566	561690	C 351	LH HAT RACK-FLUOR 110V	MOLEX	4	561477	561476
C 288	RH SW PANEL-FRESH AIR	SWF	8	-----	561107	C 352	RH CONSOLE-DRV TEMP SENSOR	BURNDY	4	-----	561104
C 289	RH SW PANEL-SWITCH LT	SWF	2	-----	561837	C 353	INSTR PANEL RH-DRV FAN RHEOST	AMP MNL	6	561552	561515
C 290						C 354	INSTR PANEL RH-DRV TEMP CTR	AMP MNL	6	561552	561515
C 291						C 355	INSTR PANEL RH-FR TEMP CTR	AMP MNL	3	561667	561550
C 292						C 356					
C 293						C 357	INSTR PANEL RH-WATER TEMP GA	AMP MNL	3	561667	561550
C 294						C 358	INSTR PANEL RH-FUEL LEVEL GA	AMP MNL	3	561667	561550
C 295						C 359					
C 296						C 360					
C 297	INSTRUMENT PANEL RH -LTS	AMP MNL	2	560900	560898	C 361	FR ROOF-WIPER MOTOR	AMP FF	6	-----	561186
C 298						C 362	FR ROOF-LAVATORY OCCUPIED LT	AMP MNL	2	561248	561247
C 299	LH CONSOLE SW-GALLEY	SWF	8	-----	561107	C 363	FR ROOF-WATCH YOUR STEP LT	AMP MNL	2	561248	561247
C 300						C 364	FR ROOF-DESTINATION SIGN	AMP MNL	3	561667	561550
C 301						C 365	FR ROOF-UP WINDSHIELD DEFROST	AMP MNL	3	561667	561550
C 302						C 366	RH DASH PANEL-GRN & RED LEDS	AMP MNL	3	560908	562006
C 303						C 367	ENGINE COMPT-DIF OIL T SENSOR	PED WP	2	561566	561690
C 304						C 368	FR ROOF-DEST. SIGN BALLAST	AMP MNL	3	561667	561550
C 305						C 369	FR ROOF-DEST. SIGN OPER. SW	TORRIX	5	-----	562110
C 306						C 370	FR ROOF-DEST. SIGN FLUOR.	AMP MNL	2	560900	560898
C 307						C 371	FR ROOF-DEST. SIGN FLUOR.	AMP MNL	2	560900	560898
C 308	LH CONSOLE SW-RHEOSTAT	TC	2	561030	560997	C 372	FR ROOF-DEST. SIGN SPEED SW	MOLEX	4	561477	561476
C 309	DDEC ENGINE-ECM POWER CON.	PED MP	5	-----	562345	C 373	FR ROOF-NO SMOKING LT	AMP MNL	2	561248	561247
C 310	LH CONSOLE SW-LUG. DOOR LCK	SWF	8	-----	561107	C 374	LH SWITCH PANEL	AMP MNL	6	561552	561515
C 311	LH CONSOLE SW-HOS & PAS CHIME	SWF	8	-----	561107	C 375					

# CONNECTORS CODE

NO	LOCATION	TYPE	CAVITY	#PIN	#SOCKET	NO	LOCATION	TYPE	CAVITY	#PIN	#SOCKET
				HOUSING	HOUSING					HOUSING	HOUSING
C 376						C 440					
C 377	LH SW PANEL-STOP ENG.OVERRIDE	SWF	8	-----	561107	C 441					
C 378						C 442					
C 379						C 443					
C 380	LH CONSOLE-DDR CONNECTOR	DEUTSCH	6	562360	-----	C 444					
C 381						C 445					
C 382						C 446					
C 383						C 447					
C 384						C 448					
C 385						C 449					
C 386	LH CONSOLE-WCL POWER SYSTEM	SWF	8	-----	561107	C 450	SOUND SYS. JCT. PANEL	MOLEX	4	562507	562503
C 387	RR JCT BOX (WCL)	AMP MNL	9	561661	561662	C 451	WIRELESS MICRO-FIRST CPT BAG	MOLEX	2	562550	562549
C 388	RR JCT BOX (WCL)	AMP MNL	12	561735	561734	C 452	UNDER DASH INSTR. PANEL	MOLEX	2	562550	562549
C 389	WCL REAR DOOR	MOLEX	4	561477	561476	C 453	SOUND SYS. JCT.PANEL-VCP	PED WP	2	561566	561680
C 390	LAVATORY WALL-WCL REMOTE CTR	SWF	8	-----	561107	C 454	SOUND SYS.JCT.PAN.-FILT. VCP	PED WP	2	561566	561680
C 391	LAVATORY WALL-WCL LAMP	SWF	8	-----	561107	C 455	WIRELESS MICRO-LH HAT-RACK	CINCH	2	562554	562551
C 392	LAVATORY WALL-WCL SW. LT.	SWF	2	-----	561835	C 456	WORLD TRANSM.-RETARDER ACCUM.	PED MP	2	-----	562427
C 393	LAVATORY WALL-WCL REMOTE SYS.	AMP CPC	4	561686	561687	C 457	WORLD TRANSM.-MAIN CONNECTOR	DEUTSCH	31	562572	562536
C 394	UNDER INSTR. PANEL- B/U MONITOR	AMP MNL	4	560851	560852	C 458	WORLD TRANSM.-TURBINE SP.SENS	PED MP	2	-----	562426
C 395	DRIVER'S COMPT. - B/U MONITOR	AMP	5	-----	-----	C 459	WORLD TRANSM.-ENGINE SP.SENS.	PED MP	2	-----	562426
C 396	FR SECT. LH HAT RACK-SPEAKER	MOLEX	4	562507	562503	C 460	WORLD TRANSM.-SPEED SENSOR	ITT	2	-----	562541
C 397	ENGINE COMPT. CRADLE ACC.	DEUTSCH	40	562281	562284	C 461	WORLD TRANSM.-RETARDER TEMP.	PED MP	2	561566	561680
C 398						C 462	WORLD TRANSM.-RETARD SOL."K"	PED MP	2	-----	562426
C 399						C 463	WORLD TRANSM.-SENSOR CONN.	DEUTSCH	16	562570	562571
C 400	ENGINE COMPT. BLOCK HEATER	PED MP	3	561781	561782	C 464	RR JCT BOX-DDR CONN W.T.	DEUTSCH	6	-----	562360
C 401						C 465	LH CONSOLE-SHIFTER SELECTOR	PED	20	-----	562825
C 402	RR DRIVE AXLE-AIR DRYER	PED MP	2	-----	562251	C 466	FR SERVICE CPT.-RESIS. MOD.	PED WP	3	-----	562428
C 403	GALLEY FRIGO NORCOLD	AMP MNL	2	561248	561247	C 467	FR SERVICE CPT.-RESIS. MOD.	PED WP	3	-----	562428
C 404	GALLEY LAMP	AMP MNL	2	561248	561247	C 468			8		
C 405						C 469					
C 406	FR JCT BOX COMPT.-ABS	AMP MNL	2	560900	560898	C 470	FR LH UPPER WHELL CPT-SILENT 1000	AMP MNL	2	561248	561247
C 407	ENGINE COMPT. -SIGNAL	PED WP	6	561606	561607	C 471	FR LH UPPER WHELL CPT-SILENT 1000	AMP MNL	2	561248	561247
C 408	ENGINE COMPT. -SIGNAL	PED WP	6	561606	561607	C 472	FR LH UPPER WHELL CPT-SILENT 1000	PED WP	2	561566	561690
C 409	ENGINE CPT -LOW COOL. LEVEL	PED MP	2	-----	562350	C 473	FR LH UPPER WHELL CPT-SILENT 1000	AMP MNL	3	561667	561550
C 410	FR JCT BOX-DIODE CONNECTOR	AMP MNL	15	561987	561986	C 474	DRIVER CPT.-TEMP. SENSOR	AMP MNL	2	561247	561248
C 411	FR JCT BOX-DIODE CONNECTOR	AMP MNL	15	561987	561986	C 475	RR JCT BOX-SPEED SIGN CONNECTOR	AMP MNL	2	561248	561247
C 412	LH SW PANEL-MASTER SWITCH	SWF	8	-----	561107	C 475M	RR JCT BOX-SPEED SIGN MANUAL TR.	MOLEX	6	562070	562069
C 413	ENG CPT-A/C HI UNLOAD PRS SW	PED WP	2	561566	561690	C 475W	RR JCT BOX-SPEED SIGN WORLD TR.	MOLEX	6	562070	562069
C 414	RR JCT BOX	AMP MNL	9	561670	561669	C 476					
C 415	ENGINE CRADLE-FAN SIGNAL	PED WP	3	561781	561782	C 477					
C 416	ENGINE CRADLE-FAN SIGNAL	PED P-C	3	562237	-----	C 478	ELECTRONIC DESTINATION SIGN	AMP CPC	9	561636	561637
C 417	FRONT JCT BOX-DIODES	AMP MNL	15	561987	561986	C 479	HVAC MODULE				
C 418	INSTR. PANEL LH-HTR WINDSH.SW	SWF	8	-----	561107	C 480					
C 419	FR JCT BOX-RETARDER OR JACOB	AMP MNL	3	561667	561550	C 481					
C 420	ENGINE COMPT. WEBASTO WATER HTR	TC	2	561597	-----	C 482					
C 421	ENGINE COMPT. WEBASTO WATER HTR	TC	1	561073	-----	C 483	FR SERVICE CPT. (NOT USED)	PED PC	2	-----	562237
C 422	ENGINE COMPT. WEBASTO WATER HTR	TC	2	561597	-----	C 384					
C 423						C 385					
C 424	UNDER INSTRUMENT PANEL CENTER	AMP MNL	3	561667	561550	C 386					
C 425	FR JCT BOX-DIODES	AMP MNL	15	561987	561986	C 387					
C 426	ENGINE COMPT. CLUTCH CTR FAN	PED WP	3	561781	561782	C 388					
C 427						C 389					
C 428						C 390					
C 429	FR JCT BOX COMPT.	AMP MNL	6	561552	561515	C 391					
C 430	LH CONSOLE-TIMER	AMP FF	8	561188	562363	C 392					
C 431	LH CONSOLE-PRE HEAT.	TAB AMP	1	561540	561539	C 393					
C 432	ENGINE CPT.-PROX. SW. DOOR AJAR	DEUTSCH	4	562479	562477	C 394					
C 433	FR SERVICE CPT. KNEEL. PRESS. SW	PED WP	2	561566	561690	C 395					
C 434	FRONT JCT. BOX-DIODES	AMP MNL	15	561987	561986	C 396					
C 435	FR SERVICE CPT.(RH) KNEEL. PIEZO	AMP MNL	2	560900	560898	C 397					
C 436	RH HAT RACK-WCL CENTER ROOF ACC	AMP CPC	16	561639	561640	C 398					
C 437	RH HAT RACK-WCL FR & RR SECT.	AMP CPC	24	561642	561643	C 399					
C 438						C 500	FR LH UPPER WHELL CPT -PRODRIVER	MOLEX	6	562070	562069
C 439						C 501	FR LH UPPER WHELL CPT -PRODRIVER	PED MP	7	562433	-----

# CONNECTORS CODE

NO	LOCATION	TYPE	CAVITY	#PIN	#SOCKET	NO	LOCATION	TYPE	CAVITY	#PIN	#SOCKET
				HOUSING	HOUSING					HOUSING	HOUSING
C 502	LH CONSOLE-PRE HEATER SW.	SWF	8	-----	561107	C 568	SOUND SYS. JCT. PANEL - PASS. SPK	CINCH	4	562553	562552
C 503	LH CONSOLE-PRE HEATER SW.	SWF	2	-----	561837	C 569	SOUND SYS. JCT. PANEL - POWER AMPLI.	MOLEX	9	562556	562555
C 504	LH CONSOLE WEBASTO TIMER	AMP	8	561188	562363	C 570	UNDER DASH PANEL TTLT	MOLEX	6		562464
C 505	LH CONSOLE ESPARO TIMER	AMP	9	-----	562681	C 571	UNDER DASH PANEL TTLT	MOLEX	20		562778
C 506	FR JCT BOX CPT. DIGITAL CLOCK	AMP	4	561685	561687	C 572	UNDER DASH PANEL TTLT	MOLEX	18		562779
C 507	FR SECT. LH HAT-RACK DIG. CLOCK	MOLEX	4	561477	561476	C 573	UNDER DASH PANEL TTLT	MOLEX	16		562465
C 508	RR JCT BOX-FAN CLUTCH RETARDER	AMP MNL	6	561552	561515	C 574	HAT -RACK FLUOR. INDIRECT LIGHTING	MOLEX	6	-----	562759
C 509	FR LH UPPER WHELL CPT -DATA LOGGER	PED MP	16	-----	562530	C 575					
C 510	FR LH UPPER WHELL CPT -DATA LOGGER	DEUTSCH	9	562531	-----	C 576					
C 511	FR LH UPPER WHELL CPT -DATA LOGGER	PED MP	4	562532	-----	C 577					
C 512	FR LH UPPER WHELL CPT -DATA LOGGER	PED MP	10	562533	-----	C 578					
C 513	FR LH UPPER WHELL CPT -DATA LOGGER	AMP MNL	3	561667	561550	C 579					
C 514	FR LH UPPER WHELL CPT -DATA LOGGER	PED MP	6	562433	562417	C 580					
C 515	FR JCT BOX CPT.-INTERCOM	MOLEX	4	561477	561476	C 581					
C 516	FR JCT BOX CPT.-INTERCOM	MOLEX	6	562070	562069	C 582	FRONT SERVICE CMPT. - WINDOWS AJAR	PED WP	2	561566	561690
C 517	LAVATORY WALL-INTERCOM	MOLEX	6	562070	562069	C 583	L.H. DASH PANEL - MASTER KEY	DEUTSCH	2	562486	562485
C 519	UNDER DASH RH-SEDAN DOOR	HUMPHREY	2	-----	562580	C 584	FRONT SERVICE CMPT. - AIR HORH	HUMPHREY	3	-----	641385
C 520	UNDER DASH RH-SEDAN DOOR	HUMPHREY	2	-----	641385	C 585					
C 521	UNDER DASH RH-SEDAN DOOR	HUMPHREY	2	-----	641385	C 586					
C 522	FR JCT BOX-DAYTIME LTS MODULE	BOSCH	5	-----	561183	C 587					
C 523	FR JCT BOX-FUSE BLOCK	PED	8	562647	562646	C 588	FRONT SERVICE CPT. CENTER SOUND SYS.	AMP. CPC	37	561645	561646
C 524	FR JCT BOX-FUSE BLOCK	PED	8	562647	562646	C 589	UNDER DASH - L.H. MIRROR	AMP MNL	9	561670	561669
C 525	FR JCT BOX-FUSE BLOCK	PED	8	562647	562646	C 590	UNDER DASH - R.H. MIRROR	AMP MNL	9	561670	561669
C 526	FR JCT BOX-FUSE BLOCK	PED	8	562647	562646	C 591	L.H.CONSOLE - MIRROR L.H.	EURAMTEC	8	-----	562799
C 527	FR JCT BOX-FUSE BLOCK	PED	8	562647	562646	C 592	L.H.CONSOLE - MIRROR R.H.	EURAMTEC	8	-----	562799
C 528	FR JCT BOX-FUSE BLOCK	PED	8	562647	562646	C 593	BATTERY CMPT. - CHARGER	PED WP	3	561781	561782
C 529	FR JCT BOX-12V OUTLET	AMP MNL	2	561247	561248	C 594	FRONT ROOF - DRIVERS LIGHT	LEEKRAFT		-----	562803
C 530	RR JCT BOX-FUSE BLOCK	PED	8	562647	562646	C 595	DASH CENTER MODULE - OPEN DOOR	MOLEX	4	561477	561476
C 531	RR JCT BOX-FUSE BLOCK	PED	8	562647	562646	C 596	DASH CENTER MODULE - CLOSE DOOR	MOLEX	4	561477	561476
C 532	RR JCT BOX-FUSE BLOCK	PED	8	562647	562646	C 597	L.H. DASH PANEL - DISPLAY SET SW.	MOLEX	5		562812
C 533	RR JCT BOX-FUSE BLOCK	PED	8	562647	562646	C 598	L.H. DASH PANEL - DISPLAY SET SW.	MOLEX	5		562812
C 534	RR JCT BOX-FUSE BLOCK	PED	8	562647	562646	C 599					
C 535	RR JCT BOX-FIRE MODULE DETECT.	AMP MNL	3	561667	561550	C 600	ENGINE CPT.-A/C LOW PRESS SW. UNLOAD	PED	2	562348	562471
C 536	UNDER DASH RH-DRIVER'S HTR TEMP. CTR	AMP MNL	6	561552	561515	C 601	L.H. ROOF - WINDOW AJAR	AMP MNL	2	561248	561247
C 537	BATT. CPT.-A/C PRESS. SIGN. RLY	AMP MNL	2	561248	561247	C 602	L.H. ROOF - WINDOW AJAR	MOLEX	4	561477	561476
C 538	FR SERVICE CPT.-OUTSIDE TEMP. SENSOR	AMP MNL	2	561248	561247	C 603	R.H. ROOF - WINDOW AJAR	AMP MNL	2	561248	561247
C 539	HVAC DASH MODULE OUTPUT CON	MOLEX	24		562780	C 604					
C 540	HVAC DASH MODULE INPUT CON	MOLEX	22		562781	C 605	HAT RACK - MOTOR FAN	PED	2	560997	561030
C 541	SOUND SYS. JCT PANEL-AUDIO SEAT SYS.	PED WP	2	561566	561690	C 606	HAT RACK - MOTOR FAN	PED	2	560997	561030
C 542	LH HAT RACK-AUDIO SEAT SYSTEM	AMP MNL	3	561667	561550	C 607	FRONT SERVICE CMPT. RPM SIGNAL	PED WP	2	561566	561690
C 543	RR JCT BOX-PARK. BRAKE STOP LTS RESIS.	PED WP	2	561566	561690	C 608	FRONT SERVICE CMPT. SPEED SIGNAL	PED WP	2	561566	561690
C 544	SOUND SYS JCT PANEL-AUDIO SEAT SYS.	PED WP	3	561781	562428	C 609	LAVATORY - NIGHT LIGHT				
C 545	LH HAT RACK-AUDIO SEAT SYSTEM	AMP MNL	3	561667	561550	C 610	RR JCT BOX	AMP MNL	6	561552	561515
C 546						C 611					
C 547	RH DASH PANEL-ACCESSORIES	AMP CPC	37	561645	561646	C 612					
C 548	LH DASH PANEL-T.T. LT. TEST SW.	SWF	8	-----	561107	C 613					
C 549	LH CONSOLE-FAN CLUTCH OVERRIDE SW.	SWF	8	-----	561107	C 614					
C 550	LAST LUGG. CPT. -WCL RICON	AMP CPC	16	561694	561695	C 615					
C 551	LAST LUGG. CPT. -WCL RICON	AMP CPC	16	561694	561695	C 616					
C 552	LAST LUGG. CPT. -WCL RICON	AMP CPC	9	561636	561637	L X	CLUSTER	JAE	22		562766
C 553	UNDER DASH R.H. - CONTROL. HEAD	MOLEX	16	-----	562559	L Y	CLUSTER	JAE	30		562767
C 554	UNDER DASH R.H. - CONTROL. HEAD	MOLEX	16	-----	562559	R X	CLUSTER	JAE	22		562764
C 555	UNDER DASH R.H. - CONTROL. HEAD	MOLEX	16	-----	562559						
C 556	UNDER DASH R.H. - RADIO ACC.	MOLEX	2	562550	562549						
C 557	UNDER DASH R.H. - RADIO ACC.	MOLEX	9	562556	562555						
C 558	UNDER DASH R.H. - RADIO ACC.	MOLEX	4	562507	562503						
C 559	L.H. HAT RACK - PASSENGER SPK.	MOLEX	4	562507	562503						
C 560	SOUND SYS. JCT. PANEL - POWER AMPLI	MOLEX	4	562507	562503						
C 561	L.H. HAT RACK - WIRELESS MICRO	MOLEX	4	562507	562503						
C 562	L.H. HAT RACK - VCP	MOLEX	9	562556	562555						
C 563	L.H MODESTY PANEL - DRIVERS SPK.	MOLEX	4	562507	562503						
C 564	L.H MODESTY PANEL - MICRO	MOLEX	4	562507	562503						
C 565	R.H MODESTY PANEL - MICRO	MOLEX	4	562507	562503						
C 566	L.H. CONSOLE - BOOM MICRO	MOLEX	4	562507	562503						
C 567	L.H. CONSOLE - DRIVERS MICRO	MOLEX	4	562507	562503						

# CONNECTORS CODE

NO	LOCATION	TYPE	CAVITY	#PIN	#SOCKET	NO	LOCATION	TYPE	CAVITY	#PIN	#SOCKET
				HOUSING	HOUSING					HOUSING	HOUSING
C AA1	BEHIND DASH - SONALERT	BOSCH	5		561183	C 57					
C AA2	BEHIND DASH - SONALERT	BOSCH	5		561183	C 58	RR JCT BOX AC PANEL	DEUTSCH	24	562280	562283
C X1	FR LH UPPER WHELL CPT-ABS	WABCO	18		562792	C 59	RR JCT BOX AC PANEL	AMP CPC	14	561584	561583
C X2	FR LH UPPER WHELL CPT-ABS	WABCO	6		562793	C 60	RR JCT BOX COMPT.-LT	AMP MNL	2	561248	561247
C X3	FR LH UPPER WHELL CPT-ABS	WABCO	9		562794	C 61	LUGGAGE COMPARTMENT LTS	AMP MNL	2	561248	561247
C X4	FR LH UPPER WHELL CPT-ABS	WABCO	15		562795	C 62	LUGGAGE COMPARTMENT LTS	AMP MNL	2	561248	561247
CS	RR JCT BOX ECU WORLD TR.	PED	32		562817	C 63	LUGGAGE COMPARTMENT LTS	AMP MNL	2	561248	561247
CT	RR JCT BOX ECU WORLD TR.	PED	32		562824	C 64	LUGGAGE COMPARTMENT LTS	AMP MNL	2	561248	561247
CV	RR JCT BOX ECU WORLD TR.	PED	32		562823	C 65	LUGGAGE COMPARTMENT LTS	AMP MNL	2	561248	561247
CV 12	RR JCT BOX-WORLD TRANSM. & EATON CLUSTER	AMP CPC	9	561636	561637	C 66	LUGGAGE COMPARTMENT LTS	AMP MNL	2	561248	561247
C Y		JAE	30		562765	C 67	LUGGAGE COMPARTMENT LTS	AMP MNL	2	561248	561247
C 1	FR JCT BOX COMPARTMENT	AMP CPC	14	561585	561584	C 68	LUGGAGE COMPARTMENT LTS	AMP MNL	2	561248	561247
C 2	FR JCT BOX COMPARTMENT	AMP CPC	16	561639	561640	C 69	RR AXLE ACC-INSIDE PVC END	PED WP	6	561568	561578
C 3	FR JCT BOX COMPARTMENT	AMP CPC	24	561641	561643	C 70	LH CONSOLE	AMP CPC	16	561642	561643
C 4	FR JCT BOX COMPARTMENT	AMP CPC	37	561644	561646	C 71	FR JCT BOX COMPARTMENT	AMP CPC	37	561645	561646
C 5	FR SERVICE COMPT.-UNDERNEATH	AMP CPC	37	561644	561646	C 72	FR JCT BOX COMPARTMENT	AMP CPC	24	561642	561643
C 6	FR SERVICE COMPT.-UNDERNEATH	AMP CPC	16	561639	561640	C 73	DASH CENTER PANEL	AMP CPC	16	561639	561640
C 7						C 74	FR JCT BOX COMPARTMENT	AMP CPC	37	561645	561646
C 8	FR SERVICE COMPT.-UNDERNEATH	AMP CPC	24	561641	561643	C 75					
C 9	FR SERVICE COMPT.-UNDERNEATH	AMP CPC	24	561641	561643	C 76	LUGGAGE COMPT.-AIR RET.SENS.	AMP MNL	2	561248	561247
C 10						C 77	LUGGAGE COMPT.-AIR RET.SENS.	AMP MNL	2	561248	561247
C 11	FR SERVICE COMPARTMENT	AMP CPC	37	561644	561646	C 78					
C 12	FR SERVICE COMPARTMENT	AMP CPC	16	561639	561640	C 79					
C 13	LH CONSOLE-CTR MIRROR	AMP MNL	6	561552	561515	C 80	LUGGAGE COMPT.-AIR RET.SENS.	AMP MNL	2	561248	561247
C 14	UNDER DASH-LH MIRROR	AMP MNL	9	561661	561662	C 81	PASSENGER COMPT.-AISLE LTS	AMP MNL	2	560900	560898
C 15	RR JCT BOX	AMP CPC	24	561641	561643	C 82	ENTRANCE DOOR	MOLEX	6	562070	562069
C 16	LH CONSOLE SW-CRUISE ON OFF	EATON	10	-----	562763	C 83	ENTRANCE DOOR-PROIMITY SW	MOLEX	4	561477	561476
C 17	LH CONSOLE SW-CRUISE RESUME	EATON	10	-----	562763	C 84	ENTRANCE DOOR-PRESSURE SW	PED WP	2	561566	561690
C 18	LH CONSOLE SW-CRUISE SET	EATON	10	-----	562763	C 85	UNDER INSTRUMENT PANEL LH	AMP MTA-100	-----	562248	-----
C 19	LH CONSOLE DECEL SW	EATON	10	-----	562763	C 86					
C 20	RR JCT BOX	AMP CPC	37	561644	561646	C 87	RR END ROOF	AMP CPC	9	561636	561637
C 21	RR JCT BOX	AMP CPC	24	561641	561643	C 88	RR END ROOF-CLEARANCE LTS	AMP MNL	2	560900	560898
C 22	RR JCT BOX - EATON TRANSM.	AMP MNL	6	561552	561515	C 89	RR END ROOF-B/U NONITOR	AMP CPC	4	561582	561581
C 23	DDEC ENGINE-ECM J1939	PED MP	6	-----	561962	C 90	RR JCT BOX	AMP CPC	15	561987	561986
C 24	DDEC ENGINE	PED WP	1	561605	561577	C 91	RR JCT BOX	AMP CPC	37	561714	561713
C 25	RR JCT BOX - EATON TRANSM. J1939	DEUTCH	3	562877	562884	C 92	FR LH UPPER WHELL CPT-ABS	AMP CPC	9	561635	561637
C 26	HYD & MAN TRANSM.-NEUT. & B/U	PED WP	4	561610	561611	C 93	FR LH UPPER WHELL CPT-ABS		35	-----	641094
C 27	HYD & MAN TRANSM.-SPEED SENS.	PED WP	2	561566	561690	C 94					
C 28	EATON TRANSMISSION	DEUTCH	3	562877	562884	C 95	CONDENSOR CPT - LIQ. SOL. VALVE	PED WP	2	561566	561690
C 29	EATON TRANSMISSION	PED MP	6	562878	-----	C 96	FR AXLE ACCESSORIES	AMP CPC	14	561585	561585
C 30	RR JCT BOX - ECU EATON TRANSM.	PED MP	32	-----	562866	C 97	RR AXLE ACC-INSIDE PVC END	PED WP	6	561568	561578
C 31	RR JCT BOX - ECU EATON TRANSM.	PED MP	24	-----	562865	C 98	FR SERVICE COMPT-EL.FT.PEDAL	PED WP	3	561782	561781
C 32	DDEC ENGINE-ECM	PED	30	-----	561600	C 99	FR SERVICE COMPT LTS	AMP MNL	2	561248	561247
C 33	RR JCT BOX - EATON TRANSM.	DEUTCH	9	562531	-----	C 100					
C 34	RH. CONSOLE - EATON TRANSM. SHIFTER	PED MP	3	-----	562871	C 101	FR SERVICE COMPT-ELEC. HORNS	PED WP	2	561566	561690
C 35	RR JCT BOX	AMP CPC	24	561642	561643	C 102	FR SERV & SIDE CPT-FLASH. LH	GROTE	2	-----	562155
C 36	RH. CONSOLE - EATON TRANSM. SHIFTER	PED MP	24	-----	562874	C 103	FR SERV & SIDE CPT-MARKERS	GROTE	2	-----	562155
C 37	RR SECTION-LH HAT RACK	MOLEX	6	562558	562557	C 104	FR SERV & SIDE CPT-FLASH. RH	GROTE	2	-----	562155
C 38	RR SECTION-RH HAT RACK	MOLEX	6	562558	562557	C 105	FR SERVICE COMPT-LIQ.S.VALVE	PED WP	2	561566	561690
C 39	LH CONSOLE - EATON TRANSM. DISPLAY	AMP MNL	4	561551	561668	C 106	FR SERVICE COMPT-WATER VALVE	PED WP	2	561566	561690
C 40	RR JCT BOX - EATON TRANSM. J1939	DEUTCH	3	562877	562884	C 107	EVAPORATOR COMPT-DAMPER	PED WP	2	561566	561690
C 41	LAVATORY ROOF FLUORESCENT	AMP MNL	2	560900	560898	C 108	FR SERVICE COMPT-KNEEL.SYS	PED WP	2	561566	561690
C 42	LAVATORY BACK WALL-WTR TANK	AMP MNL	2	560900	560898	C 109	FR SERVICE COMPT-KNEEL.SYS	PED WP	2	561566	561690
C 43	LAVATORY BACK WALL-ACCES.	AMP MNL	9	561661	561662	C 110	FR SERVICE COMPT-KNEEL.SYS	PED WP	2	561566	561690
C 44	EATON TRANSM. J1939	DEUTCH	3	562877	562884	C 111	EVAPORATOR COMPT-DAMPER	DEUTSCH	2	562486	562485
C 45	FR JCT BOX COMPARTMENT	AMP CPC	24	561642	561643	C 112	EVAPORATOR COMPT-SPEED MOT CTRL	DEUTSCH	5	-----	562566
C 46	EATON TRANSM. J1939	DEUTCH	3	562877	562884	C 113	BATT. & RR J.B.CPT.MARKER LT	GROTE	2	-----	562155
C 47	FR SERVICE COMPARTMENT	AMP CPC	16	561694	561695	C 114	RR J. BOX CPT DOOR DIR LT LH	GROTE	2	-----	562155
C 48						C 115	ENGINE COMPT-AIR DRYER	PED WP	2	561566	561690
C 49	BATTERIE COMPT.-LT	AMP MNL	2	561248	561247	C 116	ENGINE COMPT. LTS	PED WP	1	561605	561577
C 50	FR SERVICE COMPT.-LOW BUOY	PED WP	1	561605	561577	C 117					
C 51						C 118	ENGINE COMPT-LAVATORY FAN	PED WP	2	561566	561690
C 52	RR JCT BOX	AMP CPC	22	561709	561710	C 119	ENGINE CPT RR DOOR RH LO LAMP	PED WP	6	561606	561607
C 53						C 120	ENGINE CPT RR DOOR LH LO LAMP	PED WP	6	561606	561607
C 54						C 121	BATTERIE CPT. DOOR DIR LT RH	GROTE	2	-----	562155
C 55	RH SWITCH PANEL	AMP CPC	9	561636	561637	C 122	ENGINE CPT-UNLOAD TAG SYSTEM	PED WP	2	561566	561690
C 56						C 123	TAG AXLE-UNLOAD TAG RH VALVE	PED WP	2	561566	561690



# CONNECTORS CODE

NO	LOCATION	TYPE	CAVITY	#PIN	#SOCKET	NO	LOCATION	TYPE	CAVITY	#PIN	#SOCKET
				HOUSING	HOUSING					HOUSING	HOUSING
C 124	ENGINE CPT-ETHER SW	PED WP	2	561566	561690	C 189	ENGINE CPT RR DOOR B/U LT	PED WP	2	561566	561690
C 125	ENGINE CPT-BU ALARM	PED WP	2	561566	561690	C 190	ENGINE CPT RR DOOR TAIL LT	PED WP	2	561566	561690
C 126	ENGINE CPT-FLUSHING PUMP	PED WP	2	561566	561690	C 191	ENGINE CPT RR DOOR RH STOP LT	PED WP	2	561566	561690
C 127	ENGINE CPT-FUEL FILTER	PED WP	2	561566	561690	C 192	ENGINE CPT RR DOOR RH DIR. LT	PED WP	2	561566	561690
C 128	ENGINE CPT-A/C COMPR.CLUTCH	ITT SS	2	561813	561812	C 193					
C 129	ENGINE CPT-PRE-HEAT WATER	AMP FF	6	561672	561186	C 194	ENGINE CPT RR DOOR LH DIR. LT	PED WP	2	561566	561690
C 130	ENGINE CPT-UNLOADER	ITT SS	2	561813	561812	C 195	ENGINE CPT RR DOOR LH STOP LT	PED WP	2	561566	561690
C 131	ENGINE CPT-UNLOADER	ITT SS	2	561813	561812	C 196	ENGINE CPT RR DOOR CYCLOP LT	PED WP	2	561566	561690
C 132	ENGINE CPT-A/C LO PRESS SW	PED WP	2	561566	561690	C 199	ENGINE CPT RR DOOR LICENCE LT	DOM AUTO	2	930210	-----
C 133	ENGINE CPT-A/C HI PRESS SW	PED WP	2	561566	561690	C 200	RH HAT RACK-FLUORESCENT	AMP MNL	2	561248	561247
C 134	FR JCT BOX-LUGGAGE DIODE CON.	AMP MNL	15	561987	561986	C 201	RH HAT RACK-FLUORESCENT	AMP MNL	2	561248	561247
C 135	FR JCT BOX-LUGGAGE DIODE CON.	AMP MNL	15	561987	561986	C 202	RH HAT RACK-INDIRECT LIGHTING	MOLEX	2	-----	562758
C 136	RR JCT BOX - A/C PANEL DIODE CONN.	AMP MNL	15	561987	561986	C 203	RH HAT RACK-INDIRECT LIGHTING	MOLEX	6	-----	562759
C 137	RR JCT BOX-TRANSMITTER	AMP MNL	2	560900	560898	C 204	RH HAT RACK-GENERAL LT	AMP MNL	2	560900	560898
C 138	RR JCT BOX-CONTROL MODULE	AMP HDP	15	-----	562012	C 205	FR SECT.-RH HAT RACK SPEAKER	AMP MNL	9	561661	561662
C 139	RR JCT BOX-LOGIC MODULE	AMP HDP	15	562011	-----	C 206	RH HAT RACK-READING LT	AMP FF	4	-----	562756
C 140	HVAC DASH MODULE THERMOMETER	MOLEX	4		562782	C 207	LH HAT RACK-READING LT	AMP FF	4	-----	562756
C 141	INSTRUMENT PANEL LH UNLOAD TAG	AMP	2	561248	561247	C 208	LH HAT RACK-BALLAST	MOLEX	2	-----	562758
C 142	LAVATORY DOOR WALL	AMP MNL	2	561248	561247	C 209	LH HAT RACK HOTESS CHIME	AMP MNL	3	561667	561550
C 143	LAVATORY DOOR WALL	AMP MNL	3	560908	562006	C 210	FR SECT.-LH HAT RACK SPEAKER	AMP MNL	9	561661	561662
C 144	UNDER LH SEAT-AISLE LTS	AMP MNL	4	560851	560852	C 211	FR ROOF-STORE LH	AMP MNL	2	560900	560898
C 145	RR JCT BOX CPT-RR SIDE LTS	AMP MNL	9	561670	561669	C 212	FR ROOF-STORE RH	AMP MNL	2	560900	560898
C 146	ENGINE CPT-MODULATOR VALVE	AMPHENOL	2	-----	560412	C 213	FR ROOF-CLEARANCE LT	AMP MNL	2	560900	560898
C 147	BATT & RR J.B.CPT-DOCK.LTS	PED WP	2	561566	561690	C 214	ENGINE CPT J1922				
C 148						C 215	TAG AXLE - A.T.C. SYSTEM				
C 149	CONDENSER CPT-FAN MOTOR	ORDNANCE	3	562555	562001	C 216	TAG AXLE - A.T.C. SYSTEM				
C 150						C 217					
C 151	EVAPORATOR CPT-THERMOSTAT	ITT SS	2	561813	562159	C 218					
C 152	CONDENSER CPT-FUEL GAUGE	PED WP	4	561610	561611	C 219					
C 153	EVAPORATOR CPT-AIR AMB. SENS	AMP MNL	2	561248	561247	C 220	RR.JCT.BOX-FUEL PRIME PUMP	TC	1	561070	561073
C 154	EVAPORATOR CPT-FRESH AIR SENS	ITT SS	2	561813	561812	C 221					
C 155	EVAPORATOR CPT-WATER VALVE	PED WP	4	561610	561611	C 222					
C 156	EVAPOR. CPT-BYPASS WATER VAL.	PED WP	2	561566	561690	C 223					
C 157	EVAPORATOR CPT-WATER PUMP	PED WP	2	561566	561690	C 224					
C 158	CONDENSER CPT-A/C LO TEMP.	PED WP	2	561566	561690	C 225					
C 159	CONDENSER CPT-A/C HI TEMP.	PED WP	2	561566	561690	C 226					
C 160	FR AXLE-ABS RH SENSOR	WABCO	2	641132	-----	C 227					
C 161	FR AXLE-ABS RH VALVE	WABCO	3	-----	641098	C 228					
C 162	FR AXLE-ABS LH VALVE	WABCO	3	-----	641098	C 229					
C 163	FR AXLE-ABS LH SENSOR	WABCO	2	641132	-----	C 230	ENG.CPT.-FUEL PRIME PUMP FEED	DEUTSCH	2	562486	562485
C 164	RR AXLE-ABS LH SENSOR	DEUTSCH	2	562486	562485	C 231	ENG.CPT.-FUEL PRIME PUMP SW.	PED WP	2	561566	561690
C 165	RR AXLE-ABS LH VALVE	WABCO	3	-----	641098	C 232	ENG.CPT.-FUEL PRIME PUMP	PED WP	2	561566	561690
C 166	RR AXLE-ABS RH VALVE	WABCO	3	-----	641098	C 233	FR. SERVICE COMPT.	VDO	8		562043
C 167	RR AXLE-ABS RH SENSOR	DEUTSCH	2	562486	562485	C 234	FR. SERVICE COMPT.	VDO	8		562044
C 168	RR AXLE-ABS OPT ATC	PED WP	2	561566	561690	C 235	FR. SERVICE COMPT.	VDO	8		562041
C 169	RR JCT BOX-SPEED SW	AMP HDP	15	-----	562012	C 236	LUGGAGE COMPARTEMENT	AMP MNL	4	560851	560852
C 170	FR JCT BOX-FLASHER UNIT	TC	2	-----	561940	C 237	UNDER DASH LH-JACOB CLUTCH SW	ITT SS	3	561111	561080
C 171	LH CONSOLE	AMP CPC	24	561642	561643	C 238	RR JCT BOX-DIODE CONNECTOR	AMP MNL	9	561670	561669
C 172	ENGINE COMPT-WATER TANK HEAT.	PED WP	2	561566	561690	C 239	FR SERVICE CPT-HI BUOY VALVE	PED WP	2	561566	561690
C 173	LAV.POTABLE-WATER TANK HEAT.	AMP MNL	2	560900	560898	C 240	FR SERVICE CPT-KNEEL PROX SW	PED WP	2	561566	561690
C 174	UNDER DASH RH-HTR MODULE	AMP MNL	9	561670	561669	C 241					
C 175	UNDER DASH RH-HTR MODULE	AMP MNL	9	561670	561669	C 242	FR SERVICE CPT-MARK & DIR LT	ITT SS	3	561111	561080
C 176	UNDER DASH RH-WIPER PULSE	AMP FF	6	-----	561186	C 243	FR SERVICE CPT-HEADLAMPS	TC	3	-----	561071
C 177	UNDER DASH RH-WIPER MOTOR	AMP FF	6	-----	561186	C 244	FR SERVICE CPT-LH FOG LAMP	ITT SS	2	561813	561812
C 178	UNDER DASH RH-LH FAN	TC	2	561030	560997	C 245	FR SERVICE CPT-RH FOG LAMP	ITT SS	2	561813	561812
C 179	UNDER DASH RH-RH FAN	TC	2	561030	560997	C 246	FR SERVICE CPT-MARK & DIR LT	ITT SS	3	561111	561080
C 180	RR JCT BOX-DIODE CONNECTOR	AMP MNL	15	561987	561986	C 247					
C 181	RR JCT BOX-DIODE CONNECTOR	AMP MNL	15	561987	561986	C 248	FR JCT BOX-WIPER PULSE GEN	AMP FF	6	-----	561108
C 182						C 249					
C 183	FR SERVICE CPT-KNEELING PAN.	PED WP	4	561610	561611	C 250					
C 184	FR SERVICE CPT-KNEELING SW	ITT SS	3	561111	561080	C 251	LH SW PANEL-FAST IDLE	EATON	8	-----	562763
C 185						C 252					
C 186	RR JCT BOX CPT.-SPEED SIGN.TR	PED WP	2	561566	561690	C 253	LH SW PANEL-ETHER	EATON	8	-----	562763
C 186M	RR JCT BOX CPT.-SPD SIGN. M.TR	PED WP	2	561566	561690	C 254	INST. PANEL RH-ENTR.DOOR SW.	TORRIX	5	-----	562110
C 186W	RR JCT BOX CPT.-SPD SIGN. WT	PED WP	2	561566	561690	C 255	LH SW PANEL-JACOB	EATON	8	-----	562763
C 187	FR JCT BOX-RPM RESISTOR CON.	AMP MNL	6	561552	561515	C 256					
C 188						C 257					

# CONNECTORS CODE

NO	LOCATION	TYPE	CAVITY	#PIN	#SOCKET	NO	LOCATION	TYPE	CAVITY	#PIN	#SOCKET
				HOUSING	HOUSING					HOUSING	HOUSING
C 258	LH SW PANEL-MULTI FUNC. SW	AMP FF	8	561188	-----	C 325	LH CONSOLE SW-KNEELING	EATON	8	-----	562763
C 259	LH SW PANEL-MULTI FUNC. SW	AMP FF	6	-----	561108	C 326	LH CONSOLE SW-SPARE	EATON	8	-----	562763
C 260	FR SERVICE CPT-LUG DOOR LCK	PED WP	6	561606	561607	C 327	ENGINE CONTROL	DEUTSCH	6	562583	562581
C 261	UNDER DASH RH-DOOR MODULE	AMP MNL	9	561670	561669	C 328	GALLEY-LAMP	AMP MNL	2	561248	561247
C 262	UNDER DASH RH-DOOR MODULE	AMP MNL	4	561551	561668	C 329	ENGINE TACHO SIGNAL	PED WP	3	561781	561789
C 263	UNDER DASH RH-DOOR MODULE	AMP MNL	3	561667	561550	C 330					
C 264	UNDER DASH RH-DOOR MODULE	AMP MNL	3	561667	561550	C 331	GALLEY MICROWAVE SW	EATON	8	-----	562763
C 265	UNDER DASH RH-DOOR MODULE	AMP HDP-20	15	562011	562012	C 332					
C 266						C 333	GALLEY RH CONTAINER SW	EATON	8	-----	562763
C 267	UNDER DASH RH	AMP CPC	24	561642	561643	C 334	GALLEY LH CONTAINER SW	EATON	8	-----	562763
C 268	UNDER DASH LH-MIRROR	AMP MNL	6	561552	561515	C 335					
C 269	UNDER DASH RH-MIRROR	AMP MNL	6	561552	561515	C 336					
C 270	LH MIRROR POST	MOLEX	6	562070	562069	C 337	INSTR PANEL LH-UP WIPER SW	EATON	8	-----	562763
C 271	RH MIRROR POST	MOLEX	6	562070	562069	C 338	INSTR PANEL LH-UP DEFROST SW	EATON	8	-----	562763
C 272	LH MIRROR	SPARTAN	6	-----	990158	C 339	INSTR PANEL LH-UP WASHER SW	EATON	8	-----	562763
C 273	RH MIRROR	SPARTAN	6	-----	990158	C 340	FR JCT. BOX FIRE PIEZO ALARM	AMP MNL	2	560900	560898
C 274						C 341	INSTR PANEL LH-HEAT MIRROR SW	EATON	8	-----	562763
C 275	UNDER DASH RH-DOOR MODULE	AMP MNL	9	561670	561669	C 342	ENGINE RR START SW	DEUTSCH	2	562586	562585
C 276	UNDER DASH RH-LOCK SOL.VALVE	AMP MNL	2	561248	561247	C 343	INSTR PANEL LH-HEADLAMP SW	EATON	8	-----	562763
C 277						C 344	INSTR PANEL LH-HAZARD LT SW	EATON	8	-----	562763
C 278						C 345	INSTR PANEL LH-FOG LT SW	EATON	8	-----	562763
C 279	UNDER DASH CYLINDER READ SW.	AMP MNL	2	561248	561247	C 346					
C 280	LH CONSOLE-UNLOAD TAG SW.	NGR	10	-----	562763	C 347	INSTR PANEL LH-DASH LT SW	AMP MNL	2	560900	560898
C 281						C 348	INSTR PANEL CENT-RACOR MODULE	MOLEX	6	562070	562067
C 282						C 349					
C 283						C 350	RH CONSOLE-THERMOMETER	AMP MNL	3	561667	561550
C 284						C 351	LH HAT RACK-FLUOR 110V	MOLEX	4	561477	561476
C 285						C 352	RH CONSOLE-DRV TEMP SENSOR	BURNDY	4	-----	561104
C 286	RH SW PANEL-A/C & HEAT	EATON	8	-----	562763	C 353	INSTR PANEL RH-DRV FAN RHEOST	AMP MNL	6	561552	561515
C 287	ENGINE COMPT-LTS SW	PED WP	2	561566	561690	C 354	INSTR PANEL RH-DRV TEMP CTR	AMP MNL	6	561552	561515
C 288	RH SW PANEL-FRESH AIR	EATON	8	-----	562763	C 355	INSTR PANEL RH-FR TEMP CTR	AMP MNL	3	561667	561550
C 289						C 356					
C 290						C 357	INSTR PANEL RH-WATER TEMP GA	AMP MNL	3	561667	561550
C 291						C 358	INSTR PANEL RH-FUEL LEVEL GA	AMP MNL	3	561667	561550
C 292						C 359					
C 293						C 360					
C 294						C 361	FR ROOF-WIPER MOTOR	AMP FF	6	-----	561186
C 295						C 362	FR ROOF-LAVATORY OCCUPIED LT	AMP MNL	2	561248	561247
C 296						C 363	FR ROOF-WATCH YOUR STEP LT	AMP MNL	2	561248	561247
C 297	INSTRUMENT PANEL RH -LTS	AMP MNL	2	560900	560898	C 364	FR ROOF-DESTINATION SIGN	AMP MNL	3	561667	561550
C 298						C 365	FR ROOF-UP WINDSHIELD DEFROST	AMP MNL	3	561667	561550
C 299	LH CONSOLE SW-GALLEY	EATON	8	-----	562763	C 366	RH DASH PANEL-GRN & RED LEDS	AMP MNL	3	560908	562006
C 300						C 367	ENGINE COMPT-DIF OIL T SENSOR	PED WP	2	561566	561690
C 301						C 368	FR ROOF-DEST. SIGN BALLAST	AMP MNL	3	561667	561550
C 302						C 369	FR ROOF-DEST. SIGN OPER. SW	TORRIX	5	-----	562110
C 303						C 370	FR ROOF-DEST. SIGN FLUOR.	AMP MNL	2	560900	560898
C 304						C 371	FR ROOF-DEST. SIGN FLUOR.	AMP MNL	2	560900	560898
C 305						C 372	FR ROOF-DEST. SIGN SPEED SW	MOLEX	4	561477	561476
C 306						C 373	FR ROOF-NO SMOKING LT	AMP MNL	2	561248	561247
C 307						C 374	LH SWITCH PANEL	AMP MNL	6	561552	561515
C 308	LH CONSOLE SW-RHEOSTAT	TC	2	561030	560997	C 375					
C 309	DDEC ENGINE-ECM POWER CON.	PED MP	5	-----	562345	C 376					
C 310	LH CONSOLE SW-LUG. DOOR LCK	EATON	8	-----	562763	C 377	LH SW PANEL-STOP ENG.OVERRIDE	EATON	8	-----	562763
C 311	LH CONSOLE SW-HOS & PAS CHIME	EATON	8	-----	562763	C 378					
C 312	LH CONSOLE SW-READING LTS	EATON	8	-----	562763	C 379					
C 313	LH CONSOLE SW-GEN & FLUOR LTS	EATON	8	-----	562763	C 380	LH CONSOLE-DDR CONNECTOR	DEUTSCH	6	562360	-----
C 314	LH CONSOLE SW-FR DEST. SIGN	EATON	8	-----	562763	C 381					
C 315	LH CONSOLE SW-LH STORE	EATON	8	-----	562763	C 382					
C 316	LH CONSOLE SPARE SWITCH	EATON	8	-----	562763	C 383					
C 317	LH CONSOLE SW-RH STORE	EATON	8	-----	562763	C 384					
C 318	LH CONSOLE SW-DRV WINDOW LIFT	EATON	8	-----	562763	C 385					
C 319						C 386	LH CONSOLE-WCL POWER SYSTEM	EATON	8	-----	562763
C 320	LH CONSOLE SW-DRIVER'S LTS	EATON	8	-----	562763	C 387	RR JCT BOX (WCL)	AMP MNL	9	561661	561662
C 321						C 388	RR JCT BOX (WCL)	AMP MNL	12	561735	561734
C 322	LH CONSOLE DRV WIND LIFT MOT	PED PO	2	-----	561848	C 389	WCL REAR DOOR	MOLEX	4	561477	561476
C 323	LH CONSOLE CRUISE CTR SW PAN. AMP	CPC	9	561636	561637	C 390	LAVATORY WALL-WCL REMOTE CTR	EATON	8	-----	562763
C 324						C 391	LAVATORY WALL-WCL LAMP	EATON	8	-----	562763



# CONNECTORS CODE

NO	LOCATION	TYPE	CAVITY	#PIN	#SOCKET	NO	LOCATION	TYPE	CAVITY	#PIN	#SOCKET
				HOUSING	HOUSING					HOUSING	HOUSING
C 392	LAVATORY WALL-WCL SW. LT.	EATON	2	-----	561835	C 459	WORLD TRANSM.-ENGINE SP.SENS.	PED MP	2	-----	562426
C 393	LAVATORY WALL-WCL REMOTE SYS.	AMP CPC	4	561686	561687	C 460	WORLD TRANSM.-SPEED SENSOR	ITT	2	-----	562541
C 394	UNDER INSTR. PANEL- B/U MONITOR	AMP MNL	4	560851	560852	C 461	WORLD TRANSM.-RETARDER TEMP.	PED MP	2	561566	561680
C 395	DRIVER'S COMPT. - B/U MONITOR	AMP	5	-----	-----	C 462	WORLD TRANSM.-RETARD SOL."K"	PED MP	2	-----	562426
C 396	FR SECT. LH HAT RACK-SPEAKER	MOLEX	4	562507	562503	C 463	WORLD TRANSM.-SENSOR CONN.	DEUTSCH	16	562570	562571
C 397	ENGINE COMPT. CRADLE ACC.	DEUTSCH	40	562281	562284	C 464	RR JCT BOX-DDR CONNECTOR	DEUTSCH	6	-----	562360
C 398						C 465	LH CONSOLE-SHIFTER SELECTOR	PED	20	-----	562825
C 399						C 466	FR SERVICE CPT.-RESIS. MOD.	PED WP	3	-----	562428
C 400	ENGINE COMPT. BLOCK HEATER	PED MP	3	561781	561782	C 467	FR SERVICE CPT.-RESIS. MOD.	PED WP	3	-----	562428
C 401						C 468			8		
C 402	RR DRIVE AXLE-AIR DRYER	PED MP	2	-----	562251	C 469					
C 403	GALLEY FRIGO NORCOLD	AMP MNL	2	561248	561247	C 470	FR LH UPPER WHELL CPT-SILENT 1000	AMP MNL	2	561248	561247
C 404	GALLEY LAMP	AMP MNL	2	561248	561247	C 471	FR LH UPPER WHELL CPT-SILENT 1000	AMP MNL	2	561248	561247
C 405						C 472	FR LH UPPER WHELL CPT-SILENT 1000	PED WP	2	561566	561690
C 406	FR JCT BOX COMPT.-ABS	AMP MNL	2	560900	560898	C 473	FR LH UPPER WHELL CPT-SILENT 1000	AMP MNL	3	561667	561550
C 407	ENGINE COMPT. -SIGNAL	PED WP	6	561606	561607	C 474	DRIVER CPT.-TEMP. SENSOR	AMP MNL	2	561247	561248
C 408	ENGINE COMPT. -SIGNAL	PED WP	6	561606	561607	C 475	RR JCT BOX-SPEED SIGN CONNECTOR	AMP MNL	2	561248	561247
C 409	ENGINE CPT -LOW COOL. LEVEL	PED MP	2	-----	562350	C 475M	RR JCT BOX-SPEED SIGN MANUAL TR.	MOLEX	6	562070	562069
C 410	FR JCT BOX-DIODE CONNECTOR	AMP MNL	15	561987	561986	C 475W	RR JCT BOX-SPEED SIGN WORLD TR.	MOLEX	6	562070	562069
C 411	FR JCT BOX-DIODE CONNECTOR	AMP MNL	15	561987	561986	C 476					
C 412	LH SW PANEL-MASTER SWITCH	EATON	8	-----	562763	C 477					
C 413	ENG CPT-A/C HI UNLOAD PRS SW	PED WP	2	561566	561690	C 478	ELECTRONIC DESTINATION SIGN	AMP CPC	9	561636	561637
C 414	RR JCT BOX	AMP MNL	9	561670	561669	C 479	HVAC MODULE				
C 415	ENGINE CRADLE-FAN SIGNAL	PED WP	3	561781	561782	C 480	UNDER DASH LH-DR. FAN SPEED CTR. MOD	PED	4	561889	561890
C 416	ENGINE CRADLE-FAN SIGNAL	PED P-C	3	562237	-----	C 481	UNDER DASH LH-DR. FAN SPEED CTR. MOD	PED	3	561781	561782
C 417	FRONT JCT BOX-DIODES	AMP MNL	15	561987	561986	C 482					
C 418	INSTR. PANEL LH-HTR WINDSH.SW	EATON	8	-----	562763	C 483	FR SERVICE CPT. (NOT USED)	PED PC	2	-----	562237
C 419	FR JCT BOX-RETARDER OR JACOB	AMP MNL	3	561667	561550	C 484	UNDER DASH LH.-FOOT DAMPER MOTOR	PED PC	2	-----	562076
C 420	ENGINE COMPT. WEBASTO WATER HTR	TC	2	561597	-----	C 485	UNDER DASH LH.-DASH & DEFR. DAM.MOT.	AMP MNL	3	561667	561550
C 421	ENGINE COMPT. WEBASTO WATER HTR	TC	1	561073	-----	C 486					
C 422	ENGINE COMPT. WEBASTO WATER HTR	TC	2	561597	-----	C 487					
C 423						C 488					
C 424	UNDER INSTRUMENT PANEL CENTER	AMP MNL	3	561667	561550	C 489					
C 425	FR JCT BOX-DIODES	AMP MNL	15	561987	561986	C 490					
C 426	ENGINE COMPT. CLUTCH CTR FAN	PED WP	3	561781	561782	C 491					
C 427						C 492					
C 428						C 493					
C 429	FR JCT BOX COMPT.	AMP MNL	6	561552	561515	C 494					
C 430	LH CONSOLE-TIMER	AMP FF	8	561188	562363	C 495					
C 431	LH CONSOLE-PRE HEAT.	TAB AMP	1	561540	561539	C 496					
C 432	ENGINE CPT.-PROX. SW. DOOR AJAR	DEUTSCH	4	562479	562477	C 497					
C 433	FR SERVICE CPT. KNEEL. PRESS. SW	PED WP	2	561566	561690	C 498					
C 434	FRONT JCT. BOX-DIODES	AMP MNL	15	561987	561986	C 499					
C 435	FR SERVICE CPT.(RH) KNEEL. PIEZO	AMP MNL	2	560900	560898	C 500	FR LH UPPER WHELL CPT -PRODRIVER	MOLEX	6	562070	562069
C 436	RH HAT RACK-WCL CENTER ROOF ACC	AMP CPC	16	561639	561640	C 501	FR LH UPPER WHELL CPT -PRODRIVER	PED MP	7	562433	-----
C 437	RH HAT RACK-WCL FR & RR SECT.	AMP CPC	24	561642	561643	C 502	LH CONSOLE-PRE HEATER SW.	EATON	8	-----	562763
C 438						C 503	LH CONSOLE-PRE HEATER SW.	EATON	2	-----	561837
C 439						C 504	LH CONSOLE WEBASTO TIMER	AMP	8	-----	562852
C 440						C 505	LH CONSOLE ESPAR TIMER	AMP	9	-----	562681
C 441						C 506	FR JCT BOX CPT. DIGITAL CLOCK	AMP	4	561685	561687
C 442						C 507	FR SECT. LH HAT-RACK DIG. CLOCK	MOLEX	4	561477	561476
C 443						C 508	RR JCT BOX-FAN CLUTCH RETARDER	AMP MNL	6	561552	561515
C 444						C 509	FR LH UPPER WHELL CPT -DATA LOGGER	PED MP	16	-----	562530
C 445						C 510	FR LH UPPER WHELL CPT -DATA LOGGER	DEUTSCH	9	562531	-----
C 446						C 511	FR LH UPPER WHELL CPT -DATA LOGGER	PED MP	4	562532	-----
C 447						C 512	FR LH UPPER WHELL CPT -DATA LOGGER	PED MP	10	562533	-----
C 448						C 513	FR LH UPPER WHELL CPT -DATA LOGGER	AMP MNL	3	561667	561550
C 449						C 514	FR LH UPPER WHELL CPT -DATA LOGGER	PED MP	6	562433	562417
C 450	SOUND SYS. JCT. PANEL	MOLEX	4	562507	562503	C 515	FR JCT BOX CPT.-INTERCOM	MOLEX	4	561477	561476
C 451	WIRELESS MICRO-FIRST CPT BAG	MOLEX	2	562550	562549	C 516	FR JCT BOX CPT.-INTERCOM	MOLEX	6	562070	562069
C 452	UNDER DASH INSTR. PANEL	MOLEX	2	562550	562549	C 517	LAVATORY WALL-INTERCOM	MOLEX	6	562070	562069
C 453	SOUND SYS. JCT.PANEL-VCP	PED WP	2	561566	561680	C 519	UNDER DASH RH-SEDAN DOOR	HUMPHREY	2	-----	562580
C 454	SOUND SYS.JCT.PAN.-FILT. VCP	PED WP	2	561566	561680	C 520	UNDER DASH RH-SEDAN DOOR	HUMPHREY	2	-----	641385
C 455	WIRELESS MICRO-LH HAT-RACK	CINCH	2	562554	562551	C 521	UNDER DASH RH-SEDAN DOOR	HUMPHREY	2	-----	641385
C 456	WORLD TRANSM.-RETARDER ACCUM.	PED MP	2	-----	562427	C 522	FR JCT BOX-DAYTIME LTS MODULE	BOSCH	5	-----	561183
C 457	WORLD TRANSM.-MAIN CONNECTOR	DEUTSCH	31	562572	562536	C 523	FR JCT BOX-FUSE BLOCK	PED	8	562647	562646
C 458	WORLD TRANSM.-TURBINE SP.SENS	PED MP	2	-----	562426	C 524	FR JCT BOX-FUSE BLOCK	PED	8	562647	562646

# CONNECTORS CODE

NO	LOCATION	TYPE	CAVITY	#PIN	#SOCKET	NO	LOCATION	TYPE	CAVITY	#PIN	#SOCKET
				HOUSING	HOUSING					HOUSING	HOUSING
C 525	FR JCT BOX-FUSE BLOCK	PED	8	562647	562646	C 592	L.H.CONSOLE - MIRROR R.H.	EURAMTEC	8	-----	562799
C 526	FR JCT BOX-FUSE BLOCK	PED	8	562647	562646	C 593	BATTERY CMPT. - CHARGER	PED WP	3	561781	561782
C 527	FR JCT BOX-FUSE BLOCK	PED	8	562647	562646	C 594	FRONT ROOF - DRIVERS LIGHT	LEEKRAFT		-----	562803
C 528	FR JCT BOX-FUSE BLOCK	PED	8	562647	562646	C 595	DASH CENTER MODULE - OPEN DOOR	MOLEX	4	561477	561476
C 529	FR JCT BOX-12V OUTLET	AMP MNL	2	561247	561248	C 596	DASH CENTER MODULE - CLOSE DOOR	MOLEX	4	561477	561476
C 530	RR JCT BOX-FUSE BLOCK	PED	8	562647	562646	C 597	L.H. DASH PANEL - DISPLAY SET SW.	MOLEX	5		562812
C 531	RR JCT BOX-FUSE BLOCK	PED	8	562647	562646	C 598	L.H. DASH PANEL - DISPLAY SET SW.	MOLEX	5		562812
C 532	RR JCT BOX-FUSE BLOCK	PED	8	562647	562646	C 599					
C 533	RR JCT BOX-FUSE BLOCK	PED	8	562647	562646	C 600	ENGINE CPT.-A/C LOW PRESS SW. UNLOAD	PED	2	562348	562471
C 534	RR JCT BOX-FUSE BLOCK	PED	8	562647	562646	C 601	L.H. ROOF - WINDOW AJAR	AMP MNL	2	561248	561247
C 535	RR JCT BOX-FIRE MODULE DETECT.	AMP MNL	3	561667	561550	C 602	L.H. ROOF - WINDOW AJAR	MOLEX	4	561477	561476
C 536	UNDER DASH RH-DRIVER'S HTR TEMP. CTR	AMP MNL	6	561552	561515	C 603	R.H. ROOF - WINDOW AJAR	AMP MNL	2	561248	561247
C 537	BATT. CPT.-A/C PRESS. SIGN. RLY	AMP MNL	2	561248	561247	C 604					
C 538	FR SERVICE CPT.-OUTSIDE TEMP. SENSOR	AMP MNL	2	561248	561247	C 605	HAT RACK - MOTOR FAN	PED	2	560997	561030
C 539	HVAC DASH MODULE OUTPUT CON	MOLEX	24		562780	C 606	HAT RACK - MOTOR FAN	PED	2	560997	561030
C 540	HVAC DASH MODULE INPUT CON	MOLEX	22		562781	C 607	FRONT SERVICE CMPT. RPM SIGNAL	PED WP	2	561566	561690
C 541	SOUND SYS. JCT PANEL-AUDIO SEAT SYS.	PED WP	2	561566	561690	C 608	FRONT SERVICE CMPT. SPEED SIGNAL	PED WP	2	561566	561690
C 542	LH HAT RACK-AUDIO SEAT SYSTEM	AMP MNL	3	561667	561550	C 609	LAVATORY - NIGHT LIGHT				
C 543	RR JCT BOX-PARK. BRAKE STOP LTS RESIS.	PED WP	2	561566	561690	C 610	RR JCT BOX	AMP MNL	6	561552	561515
C 544	SOUND SYS JCT PANEL-AUDIO SEAT SYS.	PED WP	3	561781	562428	C 611	HAT RACK READING LTS RICON	MOLEX	6	562558	562557
C 545	LH HAT RACK-AUDIO SEAT SYSTEM	AMP MNL	3	561667	561550	C 612	HAT -RACK FLUOR. INSTATION LTS RICON	MOLEX	4	562507	562503
C 546						C 613	HAT -RACK INDIRECT LTS RICON	AMP MNL	3	561667	561550
C 547	RH DASH PANEL-ACCESSORIES	AMP CPC	37	561645	561646	C 614	HAT -RACK INDIRECT LTS RICON	AMP MNL	3	561667	561550
C 548	LH DASH PANEL-T.T. LT. TEST SW.	EATON	8	-----	562763	C 615					
C 549	LH CONSOLE-FAN CLUTCH OVERRIDE SW.	EATON	8	-----	562763	C 616					
C 550	LAST LUGG. CPT. -WCL RICON	AMP CPC	16	561694	561695	L X	CLUSTER	JAE	22		562766
C 551	LAST LUGG. CPT. -WCL RICON	AMP CPC	16	561694	561695	L Y	CLUSTER	JAE	30		562767
C 552	LAST LUGG. CPT. -WCL RICON	AMP CPC	9	561636	561637	R X	CLUSTER	JAE	22		562764
C 553	UNDER DASH R.H. - CONTROL. HEAD	MOLEX	16	-----	562559						
C 554	UNDER DASH R.H. - CONTROL. HEAD	MOLEX	16	-----	562559						
C 555	UNDER DASH R.H. - CONTROL. HEAD	MOLEX	16	-----	562559						
C 556	UNDER DASH R.H. - RADIO ACC.	MOLEX	2	562550	562549						
C 557	UNDER DASH R.H. - RADIO ACC.	MOLEX	9	562556	562555						
C 558	UNDER DASH R.H. - RADIO ACC.	MOLEX	4	562507	562503						
C 559	L.H. HAT RACK - PASSENGER SPK.	MOLEX	4	562507	562503						
C 560	SOUND SYS. JCT. PANEL - POWER AMPLI	MOLEX	4	562507	562503						
C 561	L.H. HAT RACK - WIRELESS MICRO	MOLEX	4	562507	562503						
C 562	L.H. HAT RACK - VCP	MOLEX	9	562556	562555						
C 563	L.H MODESTY PANEL - DRIVERS SPK.	MOLEX	4	562507	562503						
C 564	L.H MODESTY PANEL - MICRO	MOLEX	4	562507	562503						
C 565	R.H MODESTY PANEL - MICRO	MOLEX	4	562507	562503						
C 566	L.H. CONSOLE - BOOM MICRO	MOLEX	4	562507	562503						
C 567	L.H. CONSOLE - DRIVERS MICRO	MOLEX	4	562507	562503						
C 568	SOUND SYS. JCT. PANEL - PASS. SPK	CINCH	4	562553	562552						
C 569	SOUND SYS. JCT. PANEL - POWER AMPLI.	MOLEX	9	562556	562555						
C 570	UNDER DASH PANEL TTLT	MOLEX	6		562464						
C 571	UNDER DASH PANEL TTLT	MOLEX	20		562778						
C 572	UNDER DASH PANEL TTLT	MOLEX	18		562779						
C 573	UNDER DASH PANEL TTLT	MOLEX	16		562465						
C 574	HAT -RACK FLUOR. INDIRECT LIGHTING	MOLEX	6	-----	562759						
C 575	HAT -RACK FLUOR. INSTATION LIGHT	MOLEX	4	562507	562503						
C 576	HAT -RACK FLUOR. INDIRECT LIGHTING	AMP MNL	3	561667	561550						
C 577	HAT -RACK FLUOR. INDIRECT LIGHTING	AMP MNL	3	561667	561550						
C 578	HAT -RACK FLUOR. INSTATION LIGHT	MOLEX	4	562507	562503						
C 579											
C 580											
C 581											
C 582	FRONT SERVICE CMPT. - WINDOWS AJAR	PED WP	2	561566	561690						
C 583	L.H. DASH PANEL - MASTER KEY	DEUTSCH	2	562486	562485						
C 584	FRONT SERVICE CMPT. - AIR HORH	HUMPHREY	3	-----	641385						
C 585											
C 586											
C 587											
C 588	FRONT SERVICE CPT. CENTER SOUND SYS.	AMP. CPC	37	561645	561646						
C 589	UNDER DASH - L.H. MIRROR	AMP MNL	9	561670	561669						
C 590	UNDER DASH - R.H. MIRROR	AMP MNL	9	561670	561669						
C 591	L.H.CONSOLE - MIRROR L.H.	EURAMTEC	8	-----	562799						

# CONNECTORS CODE

NO	LOCATION	TYPE	CAVITY	#PIN	#SOCKET	NO	LOCATION	TYPE	CAVITY	#PIN	#SOCKET
				HOUSING	HOUSING					HOUSING	HOUSING
C AA1	BEHIND DASH - SONALERT	BOSCH	5		561183	C 57					
C AA2	BEHIND DASH - SONALERT	BOSCH	5		561183	C 58	RR JCT BOX AC PANEL	DEUTSCH	24	562280	562283
C X1	FR LH UPPER WHELL CPT-ABS	WABCO	18		562792	C 59	RR JCT BOX AC PANEL	AMP CPC	14	561584	561583
C X2	FR LH UPPER WHELL CPT-ABS	WABCO	6		562793	C 60	RR JCT BOX COMPT.-LT	AMP MNL	2	561248	561247
C X3	FR LH UPPER WHELL CPT-ABS	WABCO	9		562794	C 61	LUGGAGE COMPARTMENT LTS	AMP MNL	2	561248	561247
C X4	FR LH UPPER WHELL CPT-ABS	WABCO	15		562795	C 62	LUGGAGE COMPARTMENT LTS	AMP MNL	2	561248	561247
CS	RR JCT BOX ECU WORLD TR.	PED	32		562817	C 63	LUGGAGE COMPARTMENT LTS	AMP MNL	2	561248	561247
CT	RR JCT BOX ECU WORLD TR.	PED	32		562824	C 64	LUGGAGE COMPARTMENT LTS	AMP MNL	2	561248	561247
CV	RR JCT BOX ECU WORLD TR.	PED	32		562823	C 65	LUGGAGE COMPARTMENT LTS	AMP MNL	2	561248	561247
CV 12	RR JCT BOX-WORLD TRANSM. & EATON CLUSTER	AMP CPC	9	561636	561637	C 66	LUGGAGE COMPARTMENT LTS	AMP MNL	2	561248	561247
C Y		JAE	30		562765	C 67	LUGGAGE COMPARTMENT LTS	AMP MNL	2	561248	561247
C 1	FR JCT BOX COMPARTMENT	AMP CPC	14	561585	561584	C 68	LUGGAGE COMPARTMENT LTS	AMP MNL	2	561248	561247
C 2	FR JCT BOX COMPARTMENT	AMP CPC	16	561639	561640	C 69	RR AXLE ACC-INSIDE PVC END	PED WP	6	561568	561578
C 3	FR JCT BOX COMPARTMENT	AMP CPC	24	561641	561643	C 70	LH CONSOLE	AMP CPC	16	561642	561643
C 4	FR JCT BOX COMPARTMENT	AMP CPC	37	561644	561646	C 71	FR JCT BOX COMPARTMENT	AMP CPC	37	561645	561646
C 5	FR SERVICE COMPT.-UNDERNEATH	AMP CPC	37	561644	561646	C 72	FR JCT BOX COMPARTMENT	AMP CPC	24	561642	561643
C 6	FR SERVICE COMPT.-UNDERNEATH	AMP CPC	16	561639	561640	C 73	DASH CENTER PANEL	AMP CPC	16	561639	561640
C 7						C 74	FR JCT BOX COMPARTMENT	AMP CPC	37	561645	561646
C 8	FR SERVICE COMPT.-UNDERNEATH	AMP CPC	24	561641	561643	C 75					
C 9	FR SERVICE COMPT.-UNDERNEATH	AMP CPC	24	561641	561643	C 76	LUGGAGE COMPT.-AIR RET.SENS.	AMP MNL	2	561248	561247
C 10						C 77	LUGGAGE COMPT.-AIR RET.SENS.	AMP MNL	2	561248	561247
C 11	FR SERVICE COMPARTMENT	AMP CPC	37	561644	561646	C 78					
C 12	FR SERVICE COMPARTMENT	AMP CPC	16	561639	561640	C 79					
C 13	LH CONSOLE-CTR MIRROR	AMP MNL	6	561552	561515	C 80	LUGGAGE COMPT.-AIR RET.SENS.	AMP MNL	2	561248	561247
C 14	UNDER DASH-LH MIRROR	AMP MNL	9	561661	561662	C 81	PASSENGER COMPT.-AISLE LTS	AMP MNL	2	560900	560898
C 15	RR JCT BOX	AMP CPC	24	561641	561643	C 82	ENTRANCE DOOR	MOLEX	6	562070	562069
C 16	LH CONSOLE SW-CRUISE ON OFF	EATON	10	-----	562763	C 83	ENTRANCE DOOR-PROIMITY SW	MOLEX	4	561477	561476
C 17	LH CONSOLE SW-CRUISE RESUME	EATON	10	-----	562763	C 84	ENTRANCE DOOR-PRESSURE SW	PED WP	2	561566	561690
C 18	LH CONSOLE SW-CRUISE SET	EATON	10	-----	562763	C 85	UNDER INSTRUMENT PANEL LH	AMP MTA-100	-----	562248	-----
C 19	LH CONSOLE DECEL SW	EATON	10	-----	562763	C 86					
C 20	RR JCT BOX	AMP CPC	37	561644	561646	C 87	RR END ROOF	AMP CPC	9	561636	561637
C 21	RR JCT BOX	AMP CPC	24	561641	561643	C 88	RR END ROOF-CLEARANCE LTS	AMP MNL	2	560900	560898
C 22	RR JCT BOX - EATON TRANSM.	AMP MNL	6	561552	561515	C 89	RR END ROOF-B/U NONITOR	AMP CPC	4	561582	561581
C 23	DDEC ENGINE-ECM J1939	PED MP	6	-----	561962	C 90	RR JCT BOX	AMP CPC	15	561987	561986
C 24	DDEC ENGINE	PED WP	1	561605	561577	C 91	RR JCT BOX	AMP CPC	37	561714	561713
C 25	RR JCT BOX - EATON TRANSM. J1939	DEUTCH	3	562877	562884	C 92	FR LH UPPER WHELL CPT-ABS	AMP CPC	9	561635	561637
C 26	HYD & MAN TRANSM.-NEUT. & B/U	PED WP	4	561610	561611	C 93	FR LH UPPER WHELL CPT-ABS		35	-----	641094
C 27	HYD & MAN TRANSM.-SPEED SENS.	PED WP	2	561566	561690	C 94					
C 28	EATON TRANSMISSION	DEUTCH	3	562877	562884	C 95	CONDENSOR CPT - LIQ. SOL. VALVE	PED WP	2	561566	561690
C 29	EATON TRANSMISSION	PED MP	6	562878	-----	C 96	FR AXLE ACCESSORIES	AMP CPC	14	561585	561585
C 30	RR JCT BOX - ECU EATON TRANSM.	PED MP	32	-----	562866	C 97	RR AXLE ACC-INSIDE PVC END	PED WP	6	561568	561578
C 31	RR JCT BOX - ECU EATON TRANSM.	PED MP	24	-----	562865	C 98	FR SERVICE COMPT-EL.FT.PEDAL	PED WP	3	561782	561781
C 32	DDEC ENGINE-ECM	PED	30	-----	561600	C 99	FR SERVICE COMPT LTS	AMP MNL	2	561248	561247
C 33	RR JCT BOX - EATON TRANSM.	DEUTCH	9	562531	-----	C 100					
C 34	RH. CONSOLE - EATON TRANSM. SHIFTER	PED MP	3	-----	562871	C 101	FR SERVICE COMPT-ELEC. HORNS	PED WP	2	561566	561690
C 35	RR JCT BOX	AMP CPC	24	561642	561643	C 102	FR SERV & SIDE CPT-FLASH. LH	GROTE	2	-----	562155
C 36	RH. CONSOLE - EATON TRANSM. SHIFTER	PED MP	24	-----	562874	C 103	FR SERV & SIDE CPT-MARKERS	GROTE	2	-----	562155
C 37	RR SECTION-LH HAT RACK	MOLEX	6	562558	562557	C 104	FR SERV & SIDE CPT-FLASH. RH	GROTE	2	-----	562155
C 38	RR SECTION-RH HAT RACK	MOLEX	6	562558	562557	C 105	FR SERVICE COMPT-LIQ.S.VALVE	PED WP	2	561566	561690
C 39	LH CONSOLE - EATON TRANSM. DISPLAY	AMP MNL	4	561551	561668	C 106	FR SERVICE COMPT-WATER VALVE	PED WP	2	561566	561690
C 40	RR JCT BOX - EATON TRANSM. J1939	DEUTCH	3	562877	562884	C 107	EVAPORATOR COMPT-DAMPER	PED WP	2	561566	561690
C 41	LAVATORY ROOF FLUORESCENT	AMP MNL	2	560900	560898	C 108	FR SERVICE COMPT-KNEEL.SYS	PED WP	2	561566	561690
C 42	LAVATORY BACK WALL-WTR TANK	AMP MNL	2	560900	560898	C 109	FR SERVICE COMPT-KNEEL.SYS	PED WP	2	561566	561690
C 43	LAVATORY BACK WALL-ACCES.	AMP MNL	9	561661	561662	C 110	FR SERVICE COMPT-KNEEL.SYS	PED WP	2	561566	561690
C 44	EATON TRANSM. J1939	DEUTCH	3	562877	562884	C 111	EVAPORATOR COMPT-DAMPER	DEUTSCH	2	562486	562485
C 45	FR JCT BOX COMPARTMENT	AMP CPC	24	561642	561643	C 112	EVAPORATOR COMPT-SPEED MOT CTRL	DEUTSCH	5	-----	562566
C 46	EATON TRANSM. J1939	DEUTCH	3	562877	562884	C 113	BATT. & RR J.B.CPT.MARKER LT	GROTE	2	-----	562155
C 47	FR SERVICE COMPARTMENT	AMP CPC	16	561694	561695	C 114	RR J. BOX CPT DOOR DIR LT LH	GROTE	2	-----	562155
C 48						C 115	ENGINE COMPT-AIR DRYER	PED WP	2	561566	561690
C 49	BATTERIE COMPT.-LT	AMP MNL	2	561248	561247	C 116	ENGINE COMPT. LTS	PED WP	1	561605	561577
C 50	FR SERVICE COMPT.-LOW BUOY	PED WP	1	561605	561577	C 117					
C 51						C 118	ENGINE COMPT-LAVATORY FAN	PED WP	2	561566	561690
C 52	RR JCT BOX	AMP CPC	22	561709	561710	C 119	ENGINE CPT RR DOOR RH LO LAMP	PED WP	6	561606	561607
C 53						C 120	ENGINE CPT RR DOOR LH LO LAMP	PED WP	6	561606	561607
C 54						C 121	BATTERIE CPT. DOOR DIR LT RH	GROTE	2	-----	562155
C 55	RH SWITCH PANEL	AMP CPC	9	561636	561637	C 122	ENGINE CPT-UNLOAD TAG SYSTEM	PED WP	2	561566	561690
C 56						C 123	TAG AXLE-UNLOAD TAG RH VALVE	PED WP	2	561566	561690

# CONNECTORS CODE

NO	LOCATION	TYPE	CAVITY	#PIN	#SOCKET	NO	LOCATION	TYPE	CAVITY	#PIN	#SOCKET
				HOUSING	HOUSING					HOUSING	HOUSING
C 124	ENGINE CPT-ETHER SW	PED WP	2	561566	561690	C 189	ENGINE CPT RR DOOR B/U LT	PED WP	2	561566	561690
C 125	ENGINE CPT-BU ALARM	PED WP	2	561566	561690	C 190	ENGINE CPT RR DOOR TAIL LT	PED WP	2	561566	561690
C 126	ENGINE CPT-FLUSHING PUMP	PED WP	2	561566	561690	C 191	ENGINE CPT RR DOOR RH STOP LT	PED WP	2	561566	561690
C 127	ENGINE CPT-FUEL FILTER	PED WP	2	561566	561690	C 192	ENGINE CPT RR DOOR RH DIR. LT	PED WP	2	561566	561690
C 128	ENGINE CPT-A/C COMPR.CLUTCH	ITT SS	2	561813	561812	C 193					
C 129	ENGINE CPT-PRE-HEAT WATER	AMP FF	6	561672	561186	C 194	ENGINE CPT RR DOOR LH DIR. LT	PED WP	2	561566	561690
C 130	ENGINE CPT-UNLOADER	ITT SS	2	561813	561812	C 195	ENGINE CPT RR DOOR LH STOP LT	PED WP	2	561566	561690
C 131	ENGINE CPT-UNLOADER	ITT SS	2	561813	561812	C 196	ENGINE CPT RR DOOR CYCLOP LT	PED WP	2	561566	561690
C 132	ENGINE CPT-A/C LO PRESS SW	PED WP	2	561566	561690	C 199	ENGINE CPT RR DOOR LICENCE LT	DOM AUTO	2	930210	-----
C 133	ENGINE CPT-A/C HI PRESS SW	PED WP	2	561566	561690	C 200	RH HAT RACK-FLUORESCENT	AMP MNL	2	561248	561247
C 134	FR JCT BOX-LUGGAGE DIODE CON.	AMP MNL	15	561987	561986	C 201	RH HAT RACK-FLUORESCENT	AMP MNL	2	561248	561247
C 135	FR JCT BOX-LUGGAGE DIODE CON.	AMP MNL	15	561987	561986	C 202	RH HAT RACK-INDIRECT LIGHTING	MOLEX	2	-----	562758
C 136	RR JCT BOX - A/C PANEL DIODE CONN.	AMP MNL	15	561987	561986	C 203	RH HAT RACK-INDIRECT LIGHTING	MOLEX	6	-----	562759
C 137	RR JCT BOX-TRANSMITTER	AMP MNL	2	560900	560898	C 204	RH HAT RACK-GENERAL LT	AMP MNL	2	560900	560898
C 138	RR JCT BOX-CONTROL MODULE	AMP HDP	15	-----	562012	C 205	FR SECT.-RH HAT RACK SPEAKER	AMP MNL	9	561661	561662
C 139	RR JCT BOX-LOGIC MODULE	AMP HDP	15	562011	-----	C 206	RH HAT RACK-READING LT	AMP FF	4	-----	562756
C 140	HVAC DASH MODULE THERMOMETER	MOLEX	4		562782	C 207	LH HAT RACK-READING LT	AMP FF	4	-----	562756
C 141	INSTRUMENT PANEL LH UNLOAD TAG	AMP	2	561248	561247	C 208	LH HAT RACK-BALLAST	MOLEX	2	-----	562758
C 142	LAVATORY DOOR WALL	AMP MNL	2	561248	561247	C 209	LH HAT RACK HOTESS CHIME	AMP MNL	3	561667	561550
C 143	LAVATORY DOOR WALL	AMP MNL	3	560908	562006	C 210	FR SECT.-LH HAT RACK SPEAKER	AMP MNL	9	561661	561662
C 144	UNDER LH SEAT-AISLE LTS	AMP MNL	4	560851	560852	C 211	FR ROOF-STORE LH	AMP MNL	2	560900	560898
C 145	RR JCT BOX CPT-RR SIDE LTS	AMP MNL	9	561670	561669	C 212	FR ROOF-STORE RH	AMP MNL	2	560900	560898
C 146	ENGINE CPT-MODULATOR VALVE	AMPHENOL	2	-----	560412	C 213	FR ROOF-CLEARANCE LT	AMP MNL	2	560900	560898
C 147	BATT & RR J.B.CPT-DOCK.LTS	PED WP	2	561566	561690	C 214	ENGINE CPT J1922				
C 148						C 215	TAG AXLE - A.T.C. SYSTEM				
C 149	CONDENSER CPT-FAN MOTOR	ORDNANCE	3	562555	562001	C 216	TAG AXLE - A.T.C. SYSTEM				
C 150						C 217	RH DASH PANEL-FRONT CAMERA SW	EATON	8	-----	562763
C 151	EVAPORATOR CPT-THERMOSTAT	ITT SS	2	561813	562159	C 218	RH DASH PANEL-FRONT CAMERA SW	AMP MNL	2	560900	560898
C 152	CONDENSER CPT-FUEL GAUGE	PED WP	4	561610	561611	C 219					
C 153	EVAPORATOR CPT-AIR AMB. SENS	AMP MNL	2	561248	561247	C 220	RR.JCT.BOX-FUEL PRIME PUMP	TC	1	561070	561073
C 154	EVAPORATOR CPT-FRESH AIR SENS	ITT SS	2	561813	561812	C 221					
C 155	EVAPORATOR CPT-WATER VALVE	PED WP	4	561610	561611	C 222					
C 156	EVAPOR. CPT-BYPASS WATER VAL.	PED WP	2	561566	561690	C 223					
C 157	EVAPORATOR CPT-WATER PUMP	PED WP	2	561566	561690	C 224					
C 158	CONDENSER CPT-A/C LO TEMP.	PED WP	2	561566	561690	C 225					
C 159	CONDENSER CPT-A/C HI TEMP.	PED WP	2	561566	561690	C 226					
C 160	FR AXLE-ABS RH SENSOR	WABCO	2	641132	-----	C 227					
C 161	FR AXLE-ABS RH VALVE	WABCO	3	-----	641098	C 228					
C 162	FR AXLE-ABS LH VALVE	WABCO	3	-----	641098	C 229					
C 163	FR AXLE-ABS LH SENSOR	WABCO	2	641132	-----	C 230	ENG.CPT.-FUEL PRIME PUMP FEED	DEUTSCH	2	562486	562485
C 164	RR AXLE-ABS LH SENSOR	DEUTSCH	2	562486	562485	C 231	ENG.CPT.-FUEL PRIME PUMP SW.	PED WP	2	561566	561690
C 165	RR AXLE-ABS LH VALVE	WABCO	3	-----	641098	C 232	ENG.CPT.-FUEL PRIME PUMP	PED WP	2	561566	561690
C 166	RR AXLE-ABS RH VALVE	WABCO	3	-----	641098	C 233	FR. SERVICE COMPT.	VDO	8	-----	562043
C 167	RR AXLE-ABS RH SENSOR	DEUTSCH	2	562486	562485	C 234	FR. SERVICE COMPT.	VDO	8	-----	562044
C 168	RR AXLE-ABS OPT ATC	PED WP	2	561566	561690	C 235	FR. SERVICE COMPT.	VDO	8	-----	562041
C 169	RR JCT BOX-SPEED SW	AMP HDP	15	-----	562012	C 236	LUGGAGE COMPARTEMENT	AMP MNL	4	560851	560852
C 170	FR JCT BOX-FLASHER UNIT	TC	2	-----	561940	C 237	UNDER DASH LH-JACOB CLUTCH SW	ITT SS	3	561111	561080
C 171	LH CONSOLE	AMP CPC	24	561642	561643	C 238	RR JCT BOX-DIODE CONNECTOR	AMP MNL	9	561670	561669
C 172	ENGINE COMPT-WATER TANK HEAT.	PED WP	2	561566	561690	C 239	FR SERVICE CPT-HI BUOY VALVE	PED WP	2	561566	561690
C 173	LAV.POTABLE-WATER TANK HEAT.	AMP MNL	2	560900	560898	C 240	FR SERVICE CPT-KNEEL PROX SW	PED WP	2	561566	561690
C 174	UNDER DASH RH-HTR MODULE	AMP MNL	9	561670	561669	C 241					
C 175	UNDER DASH RH-HTR MODULE	AMP MNL	9	561670	561669	C 242	FR SERVICE CPT-MARK & DIR LT	ITT SS	3	561111	561080
C 176	UNDER DASH RH-WIPER PULSE	AMP FF	6	-----	561186	C 243	FR SERVICE CPT-HEADLAMPS	TC	3	-----	561071
C 177	UNDER DASH RH-WIPER MOTOR	AMP FF	6	-----	561186	C 244	FR SERVICE CPT-LH FOG LAMP	ITT SS	2	561813	561812
C 178	UNDER DASH RH-LH FAN	TC	2	561030	560997	C 245	FR SERVICE CPT-RH FOG LAMP	ITT SS	2	561813	561812
C 179	UNDER DASH RH-RH FAN	TC	2	561030	560997	C 246	FR SERVICE CPT-MARK & DIR LT	ITT SS	3	561111	561080
C 180	RR JCT BOX-DIODE CONNECTOR	AMP MNL	15	561987	561986	C 247					
C 181	RR JCT BOX-DIODE CONNECTOR	AMP MNL	15	561987	561986	C 248	FR JCT BOX-WIPER PULSE GEN	AMP FF	6	-----	561108
C 182						C 249					
C 183	FR SERVICE CPT-KNEELING PAN.	PED WP	4	561610	561611	C 250					
C 184	FR SERVICE CPT-KNEELING SW	ITT SS	3	561111	561080	C 251	LH DASH PANEL-FAST IDLE SW	EATON	8	-----	562763
C 185						C 252					
C 186	RR JCT BOX CPT.-SPEED SIGN.TR	PED WP	2	561566	561690	C 253	LH DASH PANEL-ETHER SW	EATON	8	-----	562763
C 186M	RR JCT BOX CPT.-SPD SIGN. M.TR	PED WP	2	561566	561690	C 254	INST. PANEL RH-ENTR.DOOR SW.	TORRIX	5	-----	562110
C 186W	RR JCT BOX CPT.-SPD SIGN. WT	PED WP	2	561566	561690	C 255	LH DASH PANEL-JACOB & RETARDER SW	EATON	8	-----	562763
C 187	FR JCT BOX-RPM RESISTOR CON.	AMP MNL	6	561552	561515	C 256					
C 188						C 257					

# CONNECTORS CODE

NO	LOCATION	TYPE	CAVITY	#PIN	#SOCKET	NO	LOCATION	TYPE	CAVITY	#PIN	#SOCKET
				HOUSING	HOUSING					HOUSING	HOUSING
C 258	LH SW PANEL-MULTI FUNC. SW	AMP FF	8	561188	-----	C 325	LH DASH PANEL-KNEELING SW	EATON	8	-----	562763
C 259	LH SW PANEL-MULTI FUNC. SW	AMP FF	6	-----	561108	C 326	LH CONSOLE SW-SPARE	EATON	8	-----	562763
C 260	FR SERVICE CPT-LUG DOOR LCK	PED WP	6	561606	561607	C 327	ENGINE CONTROL	DEUTSCH	6	562583	562581
C 261	UNDER DASH RH-DOOR MODULE	AMP MNL	9	561670	561669	C 328	GALLEY-LAMP	AMP MNL	2	561248	561247
C 262	UNDER DASH RH-DOOR MODULE	AMP MNL	4	561551	561668	C 329	ENGINE TACHO SIGNAL	PED WP	3	561781	561789
C 263	UNDER DASH RH-DOOR MODULE	AMP MNL	3	561667	561550	C 330					
C 264	UNDER DASH RH-DOOR MODULE	AMP MNL	3	561667	561550	C 331	GALLEY MICROWAVE SW	EATON	8	-----	562763
C 265	UNDER DASH RH-DOOR MODULE	AMP HDP-20	15	562011	562012	C 332					
C 266						C 333	GALLEY RH CONTAINER SW	EATON	8	-----	562763
C 267	UNDER DASH RH	AMP CPC	24	561642	561643	C 334	GALLEY LH CONTAINER SW	EATON	8	-----	562763
C 268	UNDER DASH LH-MIRROR	AMP MNL	6	561552	561515	C 335					
C 269	UNDER DASH RH-MIRROR	AMP MNL	6	561552	561515	C 336					
C 270	LH MIRROR POST	MOLEX	6	562070	562069	C 337	INSTR PANEL LH-UP WIPER SW	EATON	8	-----	562763
C 271	RH MIRROR POST	MOLEX	6	562070	562069	C 338	INSTR PANEL LH-UP DEFROST SW	EATON	8	-----	562763
C 272	LH MIRROR	SPARTAN	6	-----	990158	C 339	INSTR PANEL LH-UP WASHER SW	EATON	8	-----	562763
C 273	RH MIRROR	SPARTAN	6	-----	990158	C 340	FR JCT. BOX FIRE PIEZO ALARM	AMP MNL	2	560900	560898
C 274						C 341	INSTR PANEL LH-HEAT MIRROR SW	EATON	8	-----	562763
C 275	UNDER DASH RH-DOOR MODULE	AMP MNL	9	561670	561669	C 342	ENGINE RR START SW	DEUTSCH	2	562586	562585
C 276	UNDER DASH RH-LOCK SOL.VALVE	AMP MNL	2	561248	561247	C 343	INSTR PANEL LH-HEADLAMP SW	EATON	8	-----	562763
C 277						C 344	INSTR PANEL LH-HAZARD LT SW	EATON	8	-----	562763
C 278						C 345	INSTR PANEL LH-FOG LT SW	EATON	8	-----	562763
C 279	UNDER DASH CYLINDER READ SW.	AMP MNL	2	561248	561247	C 346					
C 280	LH CONSOLE-UNLOAD TAG SW.	NGR	10	-----	562763	C 347	INSTR PANEL LH-DASH LT SW	AMP MNL	2	560900	560898
C 281						C 348	INSTR PANEL CENT-RACOR MODULE	MOLEX	6	562070	562067
C 282						C 349					
C 283						C 350	RH CONSOLE-THERMOMETER	AMP MNL	3	561667	561550
C 284						C 351	LH HAT RACK-FLUOR 110V	MOLEX	4	561477	561476
C 285						C 352	RH CONSOLE-DRV TEMP SENSOR	BURNDY	4	-----	561104
C 286	RH SW PANEL-A/C & HEAT	EATON	8	-----	562763	C 353	INSTR PANEL RH-DRV FAN RHEOST	AMP MNL	6	561552	561515
C 287	ENGINE COMPT-LTS SW	PED WP	2	561566	561690	C 354	INSTR PANEL RH-DRV TEMP CTR	AMP MNL	6	561552	561515
C 288	RH SW PANEL-FRESH AIR	EATON	8	-----	562763	C 355	INSTR PANEL RH-FR TEMP CTR	AMP MNL	3	561667	561550
C 289						C 356					
C 290						C 357	INSTR PANEL RH-WATER TEMP GA	AMP MNL	3	561667	561550
C 291						C 358	INSTR PANEL RH-FUEL LEVEL GA	AMP MNL	3	561667	561550
C 292						C 359					
C 293						C 360					
C 294						C 361	FR ROOF-WIPER MOTOR	AMP FF	6	-----	561186
C 295						C 362	FR ROOF-LAVATORY OCCUPIED LT	AMP MNL	2	561248	561247
C 296						C 363	FR ROOF-WATCH YOUR STEP LT	AMP MNL	2	561248	561247
C 297	INSTRUMENT PANEL RH -LTS	AMP MNL	2	560900	560898	C 364	FR ROOF-DESTINATION SIGN	AMP MNL	3	561667	561550
C 298						C 365	FR ROOF-UP WINDSHIELD DEFROST	AMP MNL	3	561667	561550
C 299	RH DASH PANEL SW-GALLEY	EATON	8	-----	562763	C 366	RH DASH PANEL-GRN & RED LEDS	AMP MNL	3	560908	562006
C 300						C 367	ENGINE COMPT-DIF OIL T SENSOR	PED WP	2	561566	561690
C 301						C 368	FR ROOF-DEST. SIGN BALLAST	AMP MNL	3	561667	561550
C 302						C 369	FR ROOF-DEST. SIGN OPER. SW	TORRIX	5	-----	562110
C 303						C 370	FR ROOF-DEST. SIGN FLUOR.	AMP MNL	2	560900	560898
C 304						C 371	FR ROOF-DEST. SIGN FLUOR.	AMP MNL	2	560900	560898
C 305						C 372	FR ROOF-DEST. SIGN SPEED SW	MOLEX	4	561477	561476
C 306						C 373	FR ROOF-NO SMOKING LT	AMP MNL	2	561248	561247
C 307						C 374	LH SWITCH PANEL	AMP MNL	6	561552	561515
C 308	LH CONSOLE SW-RHEOSTAT	TC	2	561030	560997	C 375					
C 309	DDEC ENGINE-ECM POWER CON.	PED MP	5	-----	562345	C 376					
C 310	LH DASH PANEL -LUG. DOOR LCK SW	EATON	8	-----	562763	C 377	LH DASH PANEL-STOP ENG.OVERRIDE SW	EATON	8	-----	562763
C 311	RH DASH PANEL -HOS & PAS CHIME SW	EATON	8	-----	562763	C 378					
C 312	RH DASH PANEL -READING LTS SW	EATON	8	-----	562763	C 379					
C 313	RH DASH PANEL -GEN & FLUOR LTS SW	EATON	8	-----	562763	C 380	LH CONSOLE-DDR CONNECTOR	DEUTSCH	6	562360	-----
C 314	LH DASH PANEL-FR DEST. SIGN SW	EATON	8	-----	562763	C 381					
C 315	LH DASH PANEL-LH STORE SW	EATON	8	-----	562763	C 382					
C 316	LH CONSOLE SPARE SWITCH	EATON	8	-----	562763	C 383					
C 317	LH DASH PANEL-RH STORE SW	EATON	8	-----	562763	C 384					
C 318	LH CONSOLE SW-DRV WINDOW LIFT	EATON	8	-----	562763	C 385					
C 319						C 386	LH DASH PANEL-WCL POWER SYSTEM SW	EATON	8	-----	562763
C 320	RH DASH PANEL-DRIVER'S LTS SW	EATON	8	-----	562763	C 387	RR JCT BOX (WCL)	AMP MNL	9	561661	561662
C 321						C 388	RR JCT BOX (WCL)	AMP MNL	12	561735	561734
C 322	LH CONSOLE DRV WIND LIFT MOT	PED PO	2	-----	561848	C 389	WCL REAR DOOR	MOLEX	4	561477	561476
C 323	LH CONSOLE CRUISE CTR SW PAN. AMP	CPC	9	561636	561637	C 390	LAVATORY WALL-WCL REMOTE CTR	EATON	8	-----	562763
C 324						C 391	LAVATORY WALL-WCL LAMP	EATON	8	-----	562763



# CONNECTORS CODE

NO	LOCATION	TYPE	CAVITY	#PIN	#SOCKET	NO	LOCATION	TYPE	CAVITY	#PIN	#SOCKET
				HOUSING	HOUSING					HOUSING	HOUSING
C 392	LAVATORY WALL-WCL SW. LT.	EATON	2	-----	561835	C 459	WORLD TRANSM.-ENGINE SP.SENS.	PED MP	2	-----	562426
C 393	LAVATORY WALL-WCL REMOTE SYS.	AMP CPC	4	561686	561687	C 460	WORLD TRANSM.-SPEED SENSOR	ITT	2	-----	562541
C 394	UNDER INSTR. PANEL- B/U MONITOR	AMP MNL	4	560851	560852	C 461	WORLD TRANSM.-RETARDER TEMP.	PED MP	2	561566	561680
C 395	DRIVER'S COMPT. - B/U MONITOR	AMP	5	-----	-----	C 462	WORLD TRANSM.-RETARD SOL."K"	PED MP	2	-----	562426
C 396	FR SECT. LH HAT RACK-SPEAKER	MOLEX	4	562507	562503	C 463	WORLD TRANSM.-SENSOR CONN.	DEUTSCH	16	562570	562571
C 397	ENGINE COMPT. CRADLE ACC.	DEUTSCH	40	562281	562284	C 464	RR JCT BOX-DDR CONNECTOR	DEUTSCH	6	-----	562360
C 398						C 465	LH CONSOLE-SHIFTER SELECTOR	PED	20	-----	562825
C 399						C 466	FR SERVICE CPT.-RESIS. MOD.	PED WP	3	-----	562428
C 400	ENGINE COMPT. BLOCK HEATER	PED MP	3	561781	561782	C 467	FR SERVICE CPT.-RESIS. MOD.	PED WP	3	-----	562428
C 401						C 468			8		
C 402	RR DRIVE AXLE-AIR DRYER	PED MP	2	-----	562251	C 469					
C 403	GALLEY FRIGO NORCOLD	AMP MNL	2	561248	561247	C 470	FR LH UPPER WHELL CPT-SILENT 1000	AMP MNL	2	561248	561247
C 404	GALLEY LAMP	AMP MNL	2	561248	561247	C 471	FR LH UPPER WHELL CPT-SILENT 1000	AMP MNL	2	561248	561247
C 405						C 472	FR LH UPPER WHELL CPT-SILENT 1000	PED WP	2	561566	561690
C 406	FR JCT BOX COMPT.-ABS	AMP MNL	2	560900	560898	C 473	FR LH UPPER WHELL CPT-SILENT 1000	AMP MNL	3	561667	561550
C 407	ENGINE COMPT. -SIGNAL	PED WP	6	561606	561607	C 474	DRIVER CPT.-TEMP. SENSOR	AMP MNL	2	561247	561248
C 408	ENGINE COMPT. -SIGNAL	PED WP	6	561606	561607	C 475	RR JCT BOX-SPEED SIGN CONNECTOR	AMP MNL	2	561248	561247
C 409	ENGINE CPT -LOW COOL. LEVEL	PED MP	2	-----	562350	C 475M	RR JCT BOX-SPEED SIGN MANUAL TR.	MOLEX	6	562070	562069
C 410	FR JCT BOX-DIODE CONNECTOR	AMP MNL	15	561987	561986	C 475W	RR JCT BOX-SPEED SIGN WORLD TR.	MOLEX	6	562070	562069
C 411	FR JCT BOX-DIODE CONNECTOR	AMP MNL	15	561987	561986	C 476					
C 412	LH DASH PANEL-MASTER SWITCH SW	EATON	8	-----	562763	C 477					
C 413	ENG CPT-A/C HI UNLOAD PRS SW	PED WP	2	561566	561690	C 478	ELECTRONIC DESTINATION SIGN	AMP CPC	9	561636	561637
C 414	RR JCT BOX	AMP MNL	9	561670	561669	C 479	HVAC MODULE				
C 415	ENGINE CRADLE-FAN SIGNAL	PED WP	3	561781	561782	C 480	UNDER DASH LH-DR. FAN SPEED CTR. MOD	PED	4	561889	561890
C 416	ENGINE CRADLE-FAN SIGNAL	PED P-C	3	562237	-----	C 481	UNDER DASH LH-DR. FAN SPEED CTR. MOD	PED	3	561781	561782
C 417	FRONT JCT BOX-DIODES	AMP MNL	15	561987	561986	C 482					
C 418	LH DASH PANEL-HTR WINDSH.SW	EATON	8	-----	562763	C 483	FR SERVICE CPT. (NOT USED)	PED PC	2	-----	562237
C 419	FR JCT BOX-RETARDER OR JACOB	AMP MNL	3	561667	561550	C 484	UNDER DASH LH.-FOOT DAMPER MOTOR	PED PC	2	-----	562076
C 420	ENGINE COMPT. WEBASTO WATER HTR	TC	2	561597	-----	C 485	UNDER DASH LH.-DASH & DEFR. DAM.MOT.	AMP MNL	3	561667	561550
C 421	ENGINE COMPT. WEBASTO WATER HTR	TC	1	561073	-----	C 486					
C 422	ENGINE COMPT. WEBASTO WATER HTR	TC	2	561597	-----	C 487					
C 423						C 488					
C 424	UNDER INSTRUMENT PANEL CENTER	AMP MNL	3	561667	561550	C 489					
C 425	FR JCT BOX-DIODES	AMP MNL	15	561987	561986	C 490					
C 426	ENGINE COMPT. CLUTCH CTR FAN	PED WP	3	561781	561782	C 491					
C 427						C 492					
C 428						C 493					
C 429	FR JCT BOX COMPT.	AMP MNL	6	561552	561515	C 494					
C 430	LH CONSOLE-TIMER	AMP FF	8	561188	562363	C 495					
C 431	LH CONSOLE-PRE HEAT.	TAB AMP	1	561540	561539	C 496					
C 432	ENGINE CPT.-PROX. SW. DOOR AJAR	DEUTSCH	4	562479	562477	C 497					
C 433	FR SERVICE CPT. KNEEL. PRESS. SW	PED WP	2	561566	561690	C 498					
C 434	FRONT JCT. BOX-DIODES	AMP MNL	15	561987	561986	C 499					
C 435	FR SERVICE CPT.(RH) KNEEL. PIEZO	AMP MNL	2	560900	560898	C 500	FR LH UPPER WHELL CPT -PRODRIVER	MOLEX	6	562070	562069
C 436	RH HAT RACK-WCL CENTER ROOF ACC	AMP CPC	16	561639	561640	C 501	FR LH UPPER WHELL CPT -PRODRIVER	PED MP	7	562433	-----
C 437	RH HAT RACK-WCL FR & RR SECT.	AMP CPC	24	561642	561643	C 502	LH DASH PANEL-PRE HEATER SW.	EATON	8	-----	562763
C 438						C 503	LH CONSOLE-PRE HEATER SW.	EATON	2	-----	561837
C 439						C 504	LH CONSOLE WEBASTO TIMER	AMP	8	-----	562852
C 440						C 505	LH CONSOLE ESPAR TIMER	AMP	9	-----	562681
C 441						C 506	FR JCT BOX CPT. DIGITAL CLOCK	AMP	4	561685	561687
C 442						C 507	FR SECT. LH HAT-RACK DIG. CLOCK	MOLEX	4	561477	561476
C 443						C 508	RR JCT BOX-FAN CLUTCH RETARDER	AMP MNL	6	561552	561515
C 444						C 509	FR LH UPPER WHELL CPT -DATA LOGGER	PED MP	16	-----	562530
C 445						C 510	FR LH UPPER WHELL CPT -DATA LOGGER	DEUTSCH	9	562531	-----
C 446						C 511	FR LH UPPER WHELL CPT -DATA LOGGER	PED MP	4	562532	-----
C 447						C 512	FR LH UPPER WHELL CPT -DATA LOGGER	PED MP	10	562533	-----
C 448						C 513	FR LH UPPER WHELL CPT -DATA LOGGER	AMP MNL	3	561667	561550
C 449						C 514	FR LH UPPER WHELL CPT -DATA LOGGER	PED MP	6	562433	562417
C 450	SOUND SYS. JCT. PANEL	MOLEX	4	562507	562503	C 515	FR JCT BOX CPT.-INTERCOM	MOLEX	4	561477	561476
C 451	WIRELESS MICRO-FIRST CPT BAG	MOLEX	2	562550	562549	C 516	FR JCT BOX CPT.-INTERCOM	MOLEX	6	562070	562069
C 452	UNDER DASH INSTR. PANEL	MOLEX	2	562550	562549	C 517	LAVATORY WALL-INTERCOM	MOLEX	6	562070	562069
C 453	SOUND SYS. JCT.PANEL-VCP	PED WP	2	561566	561680	C 519	UNDER DASH RH-SEDAN DOOR	HUMPHREY	2	-----	562580
C 454	SOUND SYS.JCT.PAN.-FILT. VCP	PED WP	2	561566	561680	C 520	UNDER DASH RH-SEDAN DOOR	HUMPHREY	2	-----	641385
C 455	WIRELESS MICRO-LH HAT-RACK	CINCH	2	562554	562551	C 521	UNDER DASH RH-SEDAN DOOR	HUMPHREY	2	-----	641385
C 456	WORLD TRANSM.-RETARDER ACCUM.	PED MP	2	-----	562427	C 522	FR JCT BOX-DAYTIME LTS MODULE	BOSCH	5	-----	561183
C 457	WORLD TRANSM.-MAIN CONNECTOR	DEUTSCH	31	562572	562536	C 523	FR JCT BOX-FUSE BLOCK	PED	8	562647	562646
C 458	WORLD TRANSM.-TURBINE SP.SENS	PED MP	2	-----	562426	C 524	FR JCT BOX-FUSE BLOCK	PED	8	562647	562646



# CONNECTORS CODE

NO	LOCATION	TYPE	CAVITY	#PIN	#SOCKET	NO	LOCATION	TYPE	CAVITY	#PIN	#SOCKET
				HOUSING	HOUSING					HOUSING	HOUSING
C 525	FR JCT BOX-FUSE BLOCK	PED	8	562647	562646	C 592	L.H.CONSOLE - MIRROR R.H.	EURAMTEC	8	-----	562799
C 526	FR JCT BOX-FUSE BLOCK	PED	8	562647	562646	C 593	BATTERY CMPT. - CHARGER	PED WP	3	561781	561782
C 527	FR JCT BOX-FUSE BLOCK	PED	8	562647	562646	C 594	FRONT ROOF - DRIVERS LIGHT	LEEKRAFT		-----	562803
C 528	FR JCT BOX-FUSE BLOCK	PED	8	562647	562646	C 595	DASH CENTER MODULE - OPEN DOOR	MOLEX	4	561477	561476
C 529	FR JCT BOX-12V OUTLET	AMP MNL	2	561247	561248	C 596	DASH CENTER MODULE - CLOSE DOOR	MOLEX	4	561477	561476
C 530	RR JCT BOX-FUSE BLOCK	PED	8	562647	562646	C 597	L.H. DASH PANEL - DISPLAY SET SW.	MOLEX	5		562812
C 531	RR JCT BOX-FUSE BLOCK	PED	8	562647	562646	C 598	L.H. DASH PANEL - DISPLAY SET SW.	MOLEX	5		562812
C 532	RR JCT BOX-FUSE BLOCK	PED	8	562647	562646	C 599					
C 533	RR JCT BOX-FUSE BLOCK	PED	8	562647	562646	C 600	ENGINE CPT.-A/C LOW PRESS SW. UNLOAD	PED	2	562348	562471
C 534	RR JCT BOX-FUSE BLOCK	PED	8	562647	562646	C 601	L.H. ROOF - WINDOW AJAR	AMP MNL	2	561248	561247
C 535	RR JCT BOX-FIRE MODULE DETECT.	AMP MNL	3	561667	561550	C 602	L.H. ROOF - WINDOW AJAR	MOLEX	4	561477	561476
C 536	UNDER DASH RH-DRIVER'S HTR TEMP. CTR	AMP MNL	6	561552	561515	C 603	R.H. ROOF - WINDOW AJAR	AMP MNL	2	561248	561247
C 537	BATT. CPT.-A/C PRESS. SIGN. RLY	AMP MNL	2	561248	561247	C 604					
C 538	FR SERVICE CPT.-OUTSIDE TEMP. SENSOR	AMP MNL	2	561248	561247	C 605	HAT RACK - MOTOR FAN	PED	2	560997	561030
C 539	HVAC DASH MODULE OUTPUT CON	MOLEX	24		562780	C 606	HAT RACK - MOTOR FAN	PED	2	560997	561030
C 540	HVAC DASH MODULE INPUT CON	MOLEX	22		562781	C 607	FRONT SERVICE CMPT. RPM SIGNAL	PED WP	2	561566	561690
C 541	SOUND SYS. JCT PANEL-AUDIO SEAT SYS.	PED WP	2	561566	561690	C 608	FRONT SERVICE CMPT. SPEED SIGNAL	PED WP	2	561566	561690
C 542	LH HAT RACK-AUDIO SEAT SYSTEM	AMP MNL	3	561667	561550	C 609	LAVATORY - NIGHT LIGHT				
C 543	RR JCT BOX-PARK. BRAKE STOP LTS RESIS.	PED WP	2	561566	561690	C 610	RR JCT BOX	AMP MNL	6	561552	561515
C 544	SOUND SYS JCT PANEL-AUDIO SEAT SYS.	PED WP	3	561781	562428	C 611	HAT RACK READING LTS RICON	MOLEX	6	562558	562557
C 545	LH HAT RACK-AUDIO SEAT SYSTEM	AMP MNL	3	561667	561550	C 612	HAT -RACK FLUOR. INSTATION LTS RICON	MOLEX	4	562507	562503
C 546						C 613	HAT -RACK INDIRECT LTS RICON	AMP MNL	3	561667	561550
C 547	RH DASH PANEL-ACCESSORIES	AMP CPC	37	561645	561646	C 614	HAT -RACK INDIRECT LTS RICON	AMP MNL	3	561667	561550
C 548	LH DASH PANEL-T.T. LT. TEST SW.	EATON	8	-----	562763	C 615					
C 549	LH DASH PANEL-FAN CLUTCH OVERR. SW	EATON	8	-----	562763	C 616					
C 550	LAST LUGG. CPT. -WCL RICON	AMP CPC	16	561694	561695	L X	CLUSTER	JAE	22		562766
C 551	LAST LUGG. CPT. -WCL RICON	AMP CPC	16	561694	561695	L Y	CLUSTER	JAE	30		562767
C 552	LAST LUGG. CPT. -WCL RICON	AMP CPC	9	561636	561637	R X	CLUSTER	JAE	22		562764
C 553	UNDER DASH R.H. - CONTROL. HEAD	MOLEX	16	-----	562559						
C 554	UNDER DASH R.H. - CONTROL. HEAD	MOLEX	16	-----	562559						
C 555	UNDER DASH R.H. - CONTROL. HEAD	MOLEX	16	-----	562559						
C 556	UNDER DASH R.H. - RADIO ACC.	MOLEX	2	562550	562549						
C 557	UNDER DASH R.H. - RADIO ACC.	MOLEX	9	562556	562555						
C 558	UNDER DASH R.H. - RADIO ACC.	MOLEX	4	562507	562503						
C 559	L.H. HAT RACK - PASSENGER SPK.	MOLEX	4	562507	562503						
C 560	SOUND SYS. JCT. PANEL - POWER AMPLI	MOLEX	4	562507	562503						
C 561	L.H. HAT RACK - WIRELESS MICRO	MOLEX	4	562507	562503						
C 562	L.H. HAT RACK - VCP	MOLEX	9	562556	562555						
C 563	L.H MODESTY PANEL - DRIVERS SPK.	MOLEX	4	562507	562503						
C 564	L.H MODESTY PANEL - MICRO	MOLEX	4	562507	562503						
C 565	R.H MODESTY PANEL - MICRO	MOLEX	4	562507	562503						
C 566	L.H. CONSOLE - BOOM MICRO	MOLEX	4	562507	562503						
C 567	L.H. CONSOLE - DRIVERS MICRO	MOLEX	4	562507	562503						
C 568	SOUND SYS. JCT. PANEL - PASS. SPK	CINCH	4	562553	562552						
C 569	SOUND SYS. JCT. PANEL - POWER AMPLI.	MOLEX	9	562556	562555						
C 570	UNDER DASH PANEL TTLT	MOLEX	6		562464						
C 571	UNDER DASH PANEL TTLT	MOLEX	20		562778						
C 572	UNDER DASH PANEL TTLT	MOLEX	18		562779						
C 573	UNDER DASH PANEL TTLT	MOLEX	16		562465						
C 574	HAT -RACK FLUOR. INDIRECT LIGHTING	MOLEX	6	-----	562759						
C 575	HAT -RACK FLUOR. INSTATION LIGHT	MOLEX	4	562507	562503						
C 576	HAT -RACK FLUOR. INDIRECT LIGHTING	AMP MNL	3	561667	561550						
C 577	HAT -RACK FLUOR. INDIRECT LIGHTING	AMP MNL	3	561667	561550						
C 578	HAT -RACK FLUOR. INSTATION LIGHT	MOLEX	4	562507	562503						
C 579											
C 580	RH DASH PANEL-HAT RACK FAN SW	EATON	8	-----	562763						
C 581											
C 582	FRONT SERVICE CMPT. - WINDOWS AJAR	PED WP	2	561566	561690						
C 583	L.H. DASH PANEL - MASTER KEY	DEUTSCH	2	562486	562485						
C 584	FRONT SERVICE CMPT. - AIR HORH	HUMPHREY	3	-----	641385						
C 585											
C 586											
C 587											
C 588	FRONT SERVICE CPT. CENTER SOUND SYS.	AMP. CPC	37	561645	561646						
C 589	UNDER DASH - L.H. MIRROR	AMP MNL	9	561670	561669						
C 590	UNDER DASH - R.H. MIRROR	AMP MNL	9	561670	561669						
C 591	L.H.CONSOLE - MIRROR L.H.	EURAMTEC	8	-----	562799						

# CONNECTORS CODE

NO	LOCATION	TYPE	CAVITY	#PIN	#SOCKET	NO	LOCATION	TYPE	CAVITY	#PIN	#SOCKET
				HOUSING	HOUSING					HOUSING	HOUSING
C AA1	BEHIND DASH - SONALERT	BOSCH	5		561183	C 57					
C AA2	BEHIND DASH - SONALERT	BOSCH	5		561183	C 58	RR JCT BOX AC PANEL	DEUTSCH	24	562280	562283
C X1	FR LH UPPER WHELL CPT-ABS	WABCO	18		562792	C 59	RR JCT BOX AC PANEL	AMP CPC	14	561584	561583
C X2	FR LH UPPER WHELL CPT-ABS	WABCO	6		562793	C 60	RR JCT BOX COMPT.-LT	AMP MNL	2	561248	561247
C X3	FR LH UPPER WHELL CPT-ABS	WABCO	9		562794	C 61	LUGGAGE COMPARTMENT LTS	AMP MNL	2	561248	561247
C X4	FR LH UPPER WHELL CPT-ABS	WABCO	15		562795	C 62	LUGGAGE COMPARTMENT LTS	AMP MNL	2	561248	561247
CS	RR JCT BOX ECU WORLD TR.	PED	32		562817	C 63	LUGGAGE COMPARTMENT LTS	AMP MNL	2	561248	561247
CT	RR JCT BOX ECU WORLD TR.	PED	32		562824	C 64	LUGGAGE COMPARTMENT LTS	AMP MNL	2	561248	561247
CV	RR JCT BOX ECU WORLD TR.	PED	32		562823	C 65	LUGGAGE COMPARTMENT LTS	AMP MNL	2	561248	561247
CV 12	RR JCT BOX-WORLD TRANSM. & EATON CLUSTER	AMP CPC	9	561636	561637	C 66	LUGGAGE COMPARTMENT LTS	AMP MNL	2	561248	561247
C Y		JAE	30		562765	C 67	LUGGAGE COMPARTMENT LTS	AMP MNL	2	561248	561247
C 1	FR JCT BOX COMPARTMENT	AMP CPC	14	561585	561584	C 68	LUGGAGE COMPARTMENT LTS	AMP MNL	2	561248	561247
C 2	FR JCT BOX COMPARTMENT	AMP CPC	16	561639	561640	C 69	RR AXLE ACC-INSIDE PVC END	PED WP	6	561568	561578
C 3	FR JCT BOX COMPARTMENT	AMP CPC	24	561641	561643	C 70	LH CONSOLE	AMP CPC	16	561642	561643
C 4	FR JCT BOX COMPARTMENT	AMP CPC	37	561644	561646	C 71	FR JCT BOX COMPARTMENT	AMP CPC	37	561645	561646
C 5	FR SERVICE COMPT.-UNDERNEATH	AMP CPC	37	561644	561646	C 72	FR JCT BOX COMPARTMENT	AMP CPC	24	561642	561643
C 6	FR SERVICE COMPT.-UNDERNEATH	AMP CPC	16	561639	561640	C 73	DASH CENTER PANEL	AMP CPC	16	561639	561640
C 7						C 74	FR JCT BOX COMPARTMENT	AMP CPC	37	561645	561646
C 8	FR SERVICE COMPT.-UNDERNEATH	AMP CPC	24	561641	561643	C 75					
C 9	FR SERVICE COMPT.-UNDERNEATH	AMP CPC	24	561641	561643	C 76	LUGGAGE COMPT.-AIR RET.SENS.	AMP MNL	2	561248	561247
C 10						C 77	LUGGAGE COMPT.-AIR RET.SENS.	AMP MNL	2	561248	561247
C 11	FR SERVICE COMPARTMENT	AMP CPC	37	561644	561646	C 78					
C 12	FR SERVICE COMPARTMENT	AMP CPC	16	561639	561640	C 79					
C 13	LH CONSOLE-CTR MIRROR	AMP MNL	6	561552	561515	C 80	LUGGAGE COMPT.-AIR RET.SENS.	AMP MNL	2	561248	561247
C 14	UNDER DASH-LH MIRROR	AMP MNL	9	561661	561662	C 81	PASSENGER COMPT.-AISLE LTS	AMP MNL	2	560900	560898
C 15	RR JCT BOX	AMP CPC	24	561641	561643	C 82	ENTRANCE DOOR	MOLEX	6	562070	562069
C 16	LH CONSOLE SW-CRUISE ON OFF	EATON	10	-----	562763	C 83	ENTRANCE DOOR-PROIMITY SW	MOLEX	4	561477	561476
C 17	LH CONSOLE SW-CRUISE RESUME	EATON	10	-----	562763	C 84	ENTRANCE DOOR-PRESSURE SW	PED WP	2	561566	561690
C 18	LH CONSOLE SW-CRUISE SET	EATON	10	-----	562763	C 85	UNDER INSTRUMENT PANEL LH	AMP MTA-100	-----	562248	-----
C 19	LH CONSOLE DECEL SW	EATON	10	-----	562763	C 86					
C 20	RR JCT BOX	AMP CPC	37	561644	561646	C 87	RR END ROOF	AMP CPC	9	561636	561637
C 21	RR JCT BOX	AMP CPC	24	561641	561643	C 88	RR END ROOF-CLEARANCE LTS	AMP MNL	2	560900	560898
C 22	RR JCT BOX - EATON TRANSM.	AMP MNL	6	561552	561515	C 89	RR END ROOF-B/U NONITOR	AMP CPC	4	561582	561581
C 23	DDEC ENGINE-ECM J1939	PED MP	6	-----	561962	C 90	RR JCT BOX	AMP CPC	15	561987	561986
C 24	DDEC ENGINE	PED WP	1	561605	561577	C 91	RR JCT BOX	AMP CPC	37	561714	561713
C 25	RR JCT BOX - EATON TRANSM. J1939	DEUTCH	3	562877	562884	C 92	FR LH UPPER WHELL CPT-ABS	AMP CPC	9	561635	561637
C 26	HYD & MAN TRANSM.-NEUT. & B/U	PED WP	4	561610	561611	C 93	FR LH UPPER WHELL CPT-ABS		35	-----	641094
C 27	HYD & MAN TRANSM.-SPEED SENS.	PED WP	2	561566	561690	C 94					
C 28	EATON TRANSMISSION	DEUTCH	3	562877	562884	C 95	CONDENSOR CPT - LIQ. SOL. VALVE	PED WP	2	561566	561690
C 29	EATON TRANSMISSION	PED MP	6	562878	-----	C 96	FR AXLE ACCESSORIES	AMP CPC	14	561585	561585
C 30	RR JCT BOX - ECU EATON TRANSM.	PED MP	32	-----	562866	C 97	RR AXLE ACC-INSIDE PVC END	PED WP	6	561568	561578
C 31	RR JCT BOX - ECU EATON TRANSM.	PED MP	24	-----	562865	C 98	FR SERVICE COMPT-EL.FT.PEDAL	PED WP	3	561782	561781
C 32	DDEC ENGINE-ECM	PED	30	-----	561600	C 99	FR SERVICE COMPT LTS	AMP MNL	2	561248	561247
C 33	RR JCT BOX - EATON TRANSM.	DEUTCH	9	562531	-----	C 100	LH CONSOLE - 120 VOLTS SWITCH	EATON	8	-----	562763
C 34	RH. CONSOLE - EATON TRANSM. SHIFTER	PED MP	3	-----	562871	C 101	FR SERVICE COMPT-ELEC. HORNS	PED WP	2	561566	561690
C 35	RR JCT BOX	AMP CPC	24	561642	561643	C 102	FR SERV & SIDE CPT-FLASH. LH	GROTE	2	-----	562155
C 36	RH. CONSOLE - EATON TRANSM. SHIFTER	PED MP	24	-----	562874	C 103	FR SERV & SIDE CPT-MARKERS	GROTE	2	-----	562155
C 37	RR SECTION-LH HAT RACK	MOLEX	6	562558	562557	C 104	FR SERV & SIDE CPT-FLASH. RH	GROTE	2	-----	562155
C 38	RR SECTION-RH HAT RACK	MOLEX	6	562558	562557	C 105	FR SERVICE COMPT-LIQ.S.VALVE	PED WP	2	561566	561690
C 39	LH CONSOLE - EATON TRANSM. DISPLAY	AMP MNL	4	561551	561668	C 106	FR SERVICE COMPT-WATER VALVE	PED WP	2	561566	561690
C 40	RR JCT BOX - EATON TRANSM. J1939	DEUTCH	3	562877	562884	C 107	EVAPORATOR COMPT-DAMPER	PED WP	2	561566	561690
C 41	LAVATORY ROOF FLUORESCENT	AMP MNL	2	560900	560898	C 108	FR SERVICE COMPT-KNEEL.SYS	PED WP	2	561566	561690
C 42	LAVATORY BACK WALL-WTR TANK	AMP MNL	2	560900	560898	C 109	FR SERVICE COMPT-KNEEL.SYS	PED WP	2	561566	561690
C 43	LAVATORY BACK WALL-ACCES.	AMP MNL	9	561661	561662	C 110	FR SERVICE COMPT-KNEEL.SYS	PED WP	2	561566	561690
C 44	EATON TRANSM. J1939	DEUTCH	3	562877	562884	C 111	EVAPORATOR COMPT-DAMPER	DEUTSCH	2	562486	562485
C 45	FR JCT BOX COMPARTMENT	AMP CPC	24	561642	561643	C 112	EVAPORATOR COMPT-SPEED MOT CTRL	DEUTSCH	5	-----	562566
C 46	EATON TRANSM. J1939	DEUTCH	3	562877	562884	C 113	BATT. & RR J.B.CPT.MARKER LT	GROTE	2	-----	562155
C 47	FR SERVICE COMPARTMENT	AMP CPC	16	561694	561695	C 114	RR J. BOX CPT DOOR DIR LT LH	GROTE	2	-----	562155
C 48						C 115	ENGINE COMPT-AIR DRYER	PED WP	2	561566	561690
C 49	BATTERIE COMPT.-LT	AMP MNL	2	561248	561247	C 116	ENGINE COMPT. LTS	PED WP	1	561605	561577
C 50	FR SERVICE COMPT.-LOW BUOY	PED WP	1	561605	561577	C 117					
C 51						C 118	ENGINE COMPT-LAVATORY FAN	PED WP	2	561566	561690
C 52	RR JCT BOX	AMP CPC	22	561709	561710	C 119	ENGINE CPT RR DOOR RH LO LAMP	PED WP	6	561606	561607
C 53						C 120	ENGINE CPT RR DOOR LH LO LAMP	PED WP	6	561606	561607
C 54						C 121	BATTERIE CPT. DOOR DIR LT RH	GROTE	2	-----	562155
C 55	RH SWITCH PANEL	AMP CPC	9	561636	561637	C 122	ENGINE CPT-UNLOAD TAG SYSTEM	PED WP	2	561566	561690
C 56						C 123	TAG AXLE-UNLOAD TAG RH VALVE	PED WP	2	561566	561690

# CONNECTORS CODE

NO	LOCATION	TYPE	CAVITY	#PIN HOUSING	#SOCKET HOUSING	NO	LOCATION	TYPE	CAVITY	#PIN HOUSING	#SOCKET HOUSING
C 124	ENGINE CPT-ETHER SW	PED WP	2	561566	561690	C 189	ENGINE CPT RR DOOR B/U LT	PED WP	2	561566	561690
C 125	ENGINE CPT-BU ALARM	PED WP	2	561566	561690	C 190	ENGINE CPT RR DOOR TAIL LT	PED WP	2	561566	561690
C 126	ENGINE CPT-FLUSHING PUMP	PED WP	2	561566	561690	C 191	ENGINE CPT RR DOOR RH STOP LT	PED WP	2	561566	561690
C 127	ENGINE CPT-FUEL FILTER	PED WP	2	561566	561690	C 192	ENGINE CPT RR DOOR RH DIR. LT	PED WP	2	561566	561690
C 128	ENGINE CPT-A/C COMPR.CLUTCH	ITT SS	2	561813	561812	C 193					
C 129	ENGINE CPT-PRE-HEAT WATER	AMP FF	6	561672	561186	C 194	ENGINE CPT RR DOOR LH DIR. LT	PED WP	2	561566	561690
C 130	ENGINE CPT-UNLOADER	ITT SS	2	561813	561812	C 195	ENGINE CPT RR DOOR LH STOP LT	PED WP	2	561566	561690
C 131	ENGINE CPT-UNLOADER	ITT SS	2	561813	561812	C 196	ENGINE CPT RR DOOR CYCLOP LT	PED WP	2	561566	561690
C 132	ENGINE CPT-A/C LO PRESS SW	PED WP	2	561566	561690	C 199	ENGINE CPT RR DOOR LICENCE LT	DOM AUTO	2	930210	-----
C 133	ENGINE CPT-A/C HI PRESS SW	PED WP	2	561566	561690	C 200	RH HAT RACK-FLUORESCENT	AMP MNL	2	561248	561247
C 134	FR JCT BOX-LUGGAGE DIODE CON.	AMP MNL	15	561987	561986	C 201	RH HAT RACK-FLUORESCENT	AMP MNL	2	561248	561247
C 135	FR JCT BOX-LUGGAGE DIODE CON.	AMP MNL	15	561987	561986	C 202	RH HAT RACK-INDIRECT LIGHTING	MOLEX	2	-----	562758
C 136	RR JCT BOX - A/C PANEL DIODE CONN.	AMP MNL	15	561987	561986	C 203	RH HAT RACK-INDIRECT LIGHTING	MOLEX	6	-----	562759
C 137	RR JCT BOX-TRANSMITTER	AMP MNL	2	560900	560898	C 204	RH HAT RACK-GENERAL LT	AMP MNL	2	560900	560898
C 138	RR JCT BOX-CONTROL MODULE	AMP HDP	15	-----	562012	C 205	FR SECT.-RH HAT RACK SPEAKER	AMP MNL	9	561661	561662
C 139	RR JCT BOX-LOGIC MODULE	AMP HDP	15	562011	-----	C 206	RH HAT RACK-READING LT	AMP FF	4	-----	562756
C 140	HVAC DASH MODULE THERMOMETER	MOLEX	4		562782	C 207	LH HAT RACK-READING LT	AMP FF	4	-----	562756
C 141	INSTRUMENT PANEL LH UNLOAD TAG	AMP	2	561248	561247	C 208	LH HAT RACK-BALLAST	MOLEX	2	-----	562758
C 142	LAVATORY DOOR WALL	AMP MNL	2	561248	561247	C 209	LH HAT RACK HOTESS CHIME	AMP MNL	3	561667	561550
C 143	LAVATORY DOOR WALL	AMP MNL	3	560908	562006	C 210	FR SECT.-LH HAT RACK SPEAKER	AMP MNL	9	561661	561662
C 144	UNDER LH SEAT-AISLE LTS	AMP MNL	4	560851	560852	C 211	FR ROOF-STORE LH	AMP MNL	2	560900	560898
C 145	RR JCT BOX CPT-RR SIDE LTS	AMP MNL	9	561670	561669	C 212	FR ROOF-STORE RH	AMP MNL	2	560900	560898
C 146	ENGINE CPT-MODULATOR VALVE	AMPHENOL	2	-----	560412	C 213	FR ROOF-CLEARANCE LT	AMP MNL	2	560900	560898
C 147	BATT & RR J.B.CPT-DOCK.LTS	PED WP	2	561566	561690	C 214	ENGINE CPT J1922				
C 148						C 215	TAG AXLE - A.T.C. SYSTEM				
C 149	CONDENSER CPT-FAN MOTOR	ORDNANCE	3	562555	562001	C 216	TAG AXLE - A.T.C. SYSTEM				
C 150						C 217	RH DASH PANEL-FRONT CAMERA SW	EATON	8	-----	562763
C 151	EVAPORATOR CPT-THERMOSTAT	ITT SS	2	561813	562159	C 218	RH DASH PANEL-FRONT CAMERA SW	AMP MNL	2	560900	560898
C 152	CONDENSER CPT-FUEL GAUGE	PED WP	4	561610	561611	C 219					
C 153	EVAPORATOR CPT-AIR AMB. SENS	AMP MNL	2	561248	561247	C 220	RR.JCT.BOX-FUEL PRIME PUMP	TC	1	561070	561073
C 154	EVAPORATOR CPT-FRESH AIR SENS	ITT SS	2	561813	561812	C 221					
C 155	EVAPORATOR CPT-WATER VALVE	PED WP	4	561610	561611	C 222					
C 156	EVAPOR. CPT-BYPASS WATER VAL.	PED WP	2	561566	561690	C 223					
C 157	EVAPORATOR CPT-WATER PUMP	PED WP	2	561566	561690	C 224					
C 158	CONDENSER CPT-A/C LO TEMP.	PED WP	2	561566	561690	C 225					
C 159	CONDENSER CPT-A/C HI TEMP.	PED WP	2	561566	561690	C 226					
C 160	FR AXLE-ABS RH SENSOR	WABCO	2	641132	-----	C 227					
C 161	FR AXLE-ABS RH VALVE	WABCO	3	-----	641098	C 228					
C 162	FR AXLE-ABS LH VALVE	WABCO	3	-----	641098	C 229					
C 163	FR AXLE-ABS LH SENSOR	WABCO	2	641132	-----	C 230	ENG.CPT.-FUEL PRIME PUMP FEED	DEUTSCH	2	562486	562485
C 164	RR AXLE-ABS LH SENSOR	DEUTSCH	2	562486	562485	C 231	ENG.CPT.-FUEL PRIME PUMP SW.	PED WP	2	561566	561690
C 165	RR AXLE-ABS LH VALVE	WABCO	3	-----	641098	C 232	ENG.CPT.-FUEL PRIME PUMP	PED WP	2	561566	561690
C 166	RR AXLE-ABS RH VALVE	WABCO	3	-----	641098	C 233	FR. SERVICE COMPT.	VDO	8	-----	562043
C 167	RR AXLE-ABS RH SENSOR	DEUTSCH	2	562486	562485	C 234	FR. SERVICE COMPT.	VDO	8	-----	562044
C 168	RR AXLE-ABS OPT ATC	PED WP	2	561566	561690	C 235	FR. SERVICE COMPT.	VDO	8	-----	562041
C 169	RR JCT BOX-SPEED SW	AMP HDP	15	-----	562012	C 236	LUGGAGE COMPARTEMENT	AMP MNL	4	560851	560852
C 170	FR JCT BOX-FLASHER UNIT	TC	2	-----	561940	C 237	UNDER DASH LH-JACOB CLUTCH SW	ITT SS	3	561111	561080
C 171	LH CONSOLE	AMP CPC	24	561642	561643	C 238	RR JCT BOX-DIODE CONNECTOR	AMP MNL	9	561670	561669
C 172	ENGINE COMPT-WATER TANK HEAT.	PED WP	2	561566	561690	C 239	FR SERVICE CPT-HI BUOY VALVE	PED WP	2	561566	561690
C 173	LAV.POTABLE-WATER TANK HEAT.	AMP MNL	2	560900	560898	C 240	FR SERVICE CPT-KNEEL PROX SW	PED WP	2	561566	561690
C 174	UNDER DASH RH-HTR MODULE	AMP MNL	9	561670	561669	C 241					
C 175	UNDER DASH RH-HTR MODULE	AMP MNL	9	561670	561669	C 242	FR SERVICE CPT-MARK & DIR LT	ITT SS	3	561111	561080
C 176	UNDER DASH RH-WIPER PULSE	AMP FF	6	-----	561186	C 243	FR SERVICE CPT-HEADLAMPS	TC	3	-----	561071
C 177	UNDER DASH RH-WIPER MOTOR	AMP FF	6	-----	561186	C 244	FR SERVICE CPT-LH FOG LAMP	ITT SS	2	561813	561812
C 178	UNDER DASH RH-LH FAN	TC	2	561030	560997	C 245	FR SERVICE CPT-RH FOG LAMP	ITT SS	2	561813	561812
C 179	UNDER DASH RH-RH FAN	TC	2	561030	560997	C 246	FR SERVICE CPT-MARK & DIR LT	ITT SS	3	561111	561080
C 180	RR JCT BOX-DIODE CONNECTOR	AMP MNL	15	561987	561986	C 247					
C 181	RR JCT BOX-DIODE CONNECTOR	AMP MNL	15	561987	561986	C 248	FR JCT BOX-WIPER PULSE GEN	AMP FF	6	-----	561108
C 182						C 249					
C 183	FR SERVICE CPT-KNEELING PAN.	PED WP	4	561610	561611	C 250					
C 184	FR SERVICE CPT-KNEELING SW	ITT SS	3	561111	561080	C 251	LH DASH PANEL-FAST IDLE SW	EATON	8	-----	562763
C 185						C 252					
C 186	RR JCT BOX CPT.-SPEED SIGN.TR	PED WP	2	561566	561690	C 253	LH DASH PANEL-ETHER SW	EATON	8	-----	562763
C 186M	RR JCT BOX CPT.-SPD SIGN. M.TR	PED WP	2	561566	561690	C 254	INST. PANEL RH-ENTR.DOOR SW.	TORRIX	5	-----	562110
C 186W	RR JCT BOX CPT.-SPD SIGN. WT	PED WP	2	561566	561690	C 255	LH DASH PANEL-JACOB & RETARDER SW	EATON	8	-----	562763
C 187	FR JCT BOX-RPM RESISTOR CON.	AMP MNL	6	561552	561515	C 256					
C 188						C 257					

# CONNECTORS CODE

NO	LOCATION	TYPE	CAVITY	#PIN	#SOCKET	NO	LOCATION	TYPE	CAVITY	#PIN	#SOCKET
				HOUSING	HOUSING					HOUSING	HOUSING
C 258	LH SW PANEL-MULTI FUNC. SW	AMP FF	8	561188	-----	C 325	LH DASH PANEL-KNEELING SW	EATON	8	-----	562763
C 259	LH SW PANEL-MULTI FUNC. SW	AMP FF	6	-----	561108	C 326	LH CONSOLE SW-SPARE	EATON	8	-----	562763
C 260	FR SERVICE CPT-LUG DOOR LCK	PED WP	6	561606	561607	C 327	ENGINE CONTROL	DEUTSCH	6	562583	562581
C 261	UNDER DASH RH-DOOR MODULE	AMP MNL	9	561670	561669	C 328	GALLEY-LAMP	AMP MNL	2	561248	561247
C 262	UNDER DASH RH-DOOR MODULE	AMP MNL	4	561551	561668	C 329	ENGINE TACHO SIGNAL	PED WP	3	561781	561789
C 263	UNDER DASH RH-DOOR MODULE	AMP MNL	3	561667	561550	C 330					
C 264	UNDER DASH RH-DOOR MODULE	AMP MNL	3	561667	561550	C 331	GALLEY MICROWAVE SW	EATON	8	-----	562763
C 265	UNDER DASH RH-DOOR MODULE	AMP HDP-20	15	562011	562012	C 332					
C 266						C 333	GALLEY RH CONTAINER SW	EATON	8	-----	562763
C 267	UNDER DASH RH	AMP CPC	24	561642	561643	C 334	GALLEY LH CONTAINER SW	EATON	8	-----	562763
C 268	UNDER DASH LH-MIRROR	AMP MNL	6	561552	561515	C 335					
C 269	UNDER DASH RH-MIRROR	AMP MNL	6	561552	561515	C 336					
C 270	LH MIRROR POST	MOLEX	6	562070	562069	C 337	INSTR PANEL LH-UP WIPER SW	EATON	8	-----	562763
C 271	RH MIRROR POST	MOLEX	6	562070	562069	C 338	INSTR PANEL LH-UP DEFROST SW	EATON	8	-----	562763
C 272	LH MIRROR	SPARTAN	6	-----	990158	C 339	INSTR PANEL LH-UP WASHER SW	EATON	8	-----	562763
C 273	RH MIRROR	SPARTAN	6	-----	990158	C 340	FR JCT. BOX FIRE PIEZO ALARM	AMP MNL	2	560900	560898
C 274	RR. JCT. BOX - SIGNAL ALT. MODULE					C 341	INSTR PANEL LH-HEAT MIRROR SW	EATON	8	-----	562763
C 275	UNDER DASH RH-DOOR MODULE	AMP MNL	9	561670	561669	C 342	ENGINE RR START SW	DEUTSCH	2	562586	562585
C 276	UNDER DASH RH-LOCK SOL.VALVE	AMP MNL	2	561248	561247	C 343	INSTR PANEL LH-HEADLAMP SW	EATON	8	-----	562763
C 277						C 344	INSTR PANEL LH-HAZARD LT SW	EATON	8	-----	562763
C 278						C 345	INSTR PANEL LH-FOG LT SW	EATON	8	-----	562763
C 279	UNDER DASH CYLINDER READ SW.	AMP MNL	2	561248	561247	C 346					
C 280	LH CONSOLE-UNLOAD TAG SW.	NGR	10	-----	562763	C 347	INSTR PANEL LH-DASH LT SW	AMP MNL	2	560900	560898
C 281						C 348	INSTR PANEL CENT-RACOR MODULE	MOLEX	6	562070	562067
C 282						C 349					
C 283						C 350	RH CONSOLE-THERMOMETER	AMP MNL	3	561667	561550
C 284						C 351	LH HAT RACK-FLUOR 110V	MOLEX	4	561477	561476
C 285						C 352	RH CONSOLE-DRV TEMP SENSOR	BURNDY	4	-----	561104
C 286	RH SW PANEL-A/C & HEAT	EATON	8	-----	562763	C 353	INSTR PANEL RH-DRV FAN RHEOST	AMP MNL	6	561552	561515
C 287	ENGINE COMPT-LTS SW	PED WP	2	561566	561690	C 354	INSTR PANEL RH-DRV TEMP CTR	AMP MNL	6	561552	561515
C 288	RH SW PANEL-FRESH AIR	EATON	8	-----	562763	C 355	INSTR PANEL RH-FR TEMP CTR	AMP MNL	3	561667	561550
C 289						C 356					
C 290						C 357	INSTR PANEL RH-WATER TEMP GA	AMP MNL	3	561667	561550
C 291						C 358	INSTR PANEL RH-FUEL LEVEL GA	AMP MNL	3	561667	561550
C 292						C 359					
C 293						C 360					
C 294						C 361	FR ROOF-WIPER MOTOR	AMP FF	6	-----	561186
C 295						C 362	FR ROOF-LAVATORY OCCUPIED LT	AMP MNL	2	561248	561247
C 296						C 363	FR ROOF-WATCH YOUR STEP LT	AMP MNL	2	561248	561247
C 297	INSTRUMENT PANEL RH -LTS	AMP MNL	2	560900	560898	C 364	FR ROOF-DESTINATION SIGN	AMP MNL	3	561667	561550
C 298						C 365	FR ROOF-UP WINDSHIELD DEFROST	AMP MNL	3	561667	561550
C 299	RH DASH PANEL SW-GALLEY	EATON	8	-----	562763	C 366	RH DASH PANEL-GRN & RED LEDS	AMP MNL	3	560908	562006
C 300						C 367	ENGINE COMPT-DIF OIL T SENSOR	PED WP	2	561566	561690
C 301						C 368	FR ROOF-DEST. SIGN BALLAST	AMP MNL	3	561667	561550
C 302						C 369	FR ROOF-DEST. SIGN OPER. SW	TORRIX	5	-----	562110
C 303						C 370	FR ROOF-DEST. SIGN FLUOR.	AMP MNL	2	560900	560898
C 304						C 371	FR ROOF-DEST. SIGN FLUOR.	AMP MNL	2	560900	560898
C 305						C 372	FR ROOF-DEST. SIGN SPEED SW	MOLEX	4	561477	561476
C 306						C 373	FR ROOF-NO SMOKING LT	AMP MNL	2	561248	561247
C 307						C 374	LH SWITCH PANEL	AMP MNL	6	561552	561515
C 308	LH CONSOLE SW-RHEOSTAT	TC	2	561030	560997	C 375					
C 309	DDEC ENGINE-ECM POWER CON.	PED MP	5	-----	562345	C 376					
C 310	LH DASH PANEL -LUG. DOOR LCK SW	EATON	8	-----	562763	C 377	LH DASH PANEL-STOP ENG.OVERRIDE SW	EATON	8	-----	562763
C 311	RH DASH PANEL -HOS & PAS CHIME SW	EATON	8	-----	562763	C 378					
C 312	RH DASH PANEL -READING LTS SW	EATON	8	-----	562763	C 379					
C 313	RH DASH PANEL -GEN & FLUOR LTS SW	EATON	8	-----	562763	C 380	LH CONSOLE-DDR CONNECTOR	DEUTSCH	6	562360	-----
C 314	LH DASH PANEL-FR DEST. SIGN SW	EATON	8	-----	562763	C 381					
C 315	LH DASH PANEL-LH STORE SW	EATON	8	-----	562763	C 382					
C 316	LH CONSOLE SPARE SWITCH	EATON	8	-----	562763	C 383					
C 317	LH DASH PANEL-RH STORE SW	EATON	8	-----	562763	C 384					
C 318	LH CONSOLE SW-DRV WINDOW LIFT	EATON	8	-----	562763	C 385					
C 319						C 386	LH DASH PANEL-WCL POWER SYSTEM SW	EATON	8	-----	562763
C 320	RH DASH PANEL-DRIVER'S LTS SW	EATON	8	-----	562763	C 387	RR JCT BOX (WCL)	AMP MNL	9	561661	561662
C 321						C 388	RR JCT BOX (WCL)	AMP MNL	12	561735	561734
C 322	LH CONSOLE DRV WIND LIFT MOT	PED PO	2	-----	561848	C 389	WCL REAR DOOR	MOLEX	4	561477	561476
C 323	LH CONSOLE CRUISE CTR SW PAN. AMP	CPC	9	561636	561637	C 390	LAVATORY WALL-WCL REMOTE CTR	EATON	8	-----	562763
C 324						C 391	LAVATORY WALL-WCL LAMP	EATON	8	-----	562763

# CONNECTORS CODE

NO	LOCATION	TYPE	CAVITY	#PIN	#SOCKET	NO	LOCATION	TYPE	CAVITY	#PIN	#SOCKET
				HOUSING	HOUSING					HOUSING	HOUSING
C 392	LAVATORY WALL-WCL SW. LT.	EATON	2	-----	561835	C 459	WORLD TRANSM.-ENGINE SP.SENS.	PED MP	2	-----	562426
C 393	LAVATORY WALL-WCL REMOTE SYS.	AMP CPC	4	561686	561687	C 460	WORLD TRANSM.-SPEED SENSOR	ITT	2	-----	562541
C 394	UNDER INSTR. PANEL- B/U MONITOR	AMP MNL	4	560851	560852	C 461	WORLD TRANSM.-RETARDER TEMP.	PED MP	2	561566	561680
C 395	DRIVER'S COMPT. - B/U MONITOR	AMP	5	-----	-----	C 462	WORLD TRANSM.-RETARD SOL."K"	PED MP	2	-----	562426
C 396	FR SECT. LH HAT RACK-SPEAKER	MOLEX	4	562507	562503	C 463	WORLD TRANSM.-SENSOR CONN.	DEUTSCH	16	562570	562571
C 397	ENGINE COMPT. CRADLE ACC.	DEUTSCH	40	562281	562284	C 464	RR JCT BOX-DDR CONNECTOR	DEUTSCH	6	-----	562360
C 398						C 465	LH CONSOLE-SHIFTER SELECTOR	PED	20	-----	562825
C 399	ENGINE COMPT. - PRE-EXITATION ALT.	PED WP	2	561566	561690	C 466	FR SERVICE CPT.-RESIS. MOD.	PED WP	3	-----	562428
C 400	ENGINE COMPT. BLOCK HEATER	PED MP	3	561781	561782	C 467	FR SERVICE CPT.-RESIS. MOD.	PED WP	3	-----	562428
C 401						C 468			8		
C 402	RR DRIVE AXLE-AIR DRYER	PED MP	2	-----	562251	C 469					
C 403	GALLEY FRIGO NORCOLD	AMP MNL	2	561248	561247	C 470	FR LH UPPER WHELL CPT-SILENT 1000	AMP MNL	2	561248	561247
C 404	GALLEY LAMP	AMP MNL	2	561248	561247	C 471	FR LH UPPER WHELL CPT-SILENT 1000	AMP MNL	2	561248	561247
C 405						C 472	FR LH UPPER WHELL CPT-SILENT 1000	PED WP	2	561566	561690
C 406	FR JCT BOX COMPT.-ABS	AMP MNL	2	560900	560898	C 473	FR LH UPPER WHELL CPT-SILENT 1000	AMP MNL	3	561667	561550
C 407	ENGINE COMPT. -SIGNAL	PED WP	6	561606	561607	C 474	DRIVER CPT.-TEMP. SENSOR	AMP MNL	2	561247	561248
C 408	ENGINE COMPT. -SIGNAL	PED WP	6	561606	561607	C 475	RR JCT BOX-SPEED SIGN CONNECTOR	AMP MNL	2	561248	561247
C 409	ENGINE CPT -LOW COOL. LEVEL	PED MP	2	-----	562350	C 475M	RR JCT BOX-SPEED SIGN MANUAL TR.	MOLEX	6	562070	562069
C 410	FR JCT BOX-DIODE CONNECTOR	AMP MNL	15	561987	561986	C 475W	RR JCT BOX-SPEED SIGN WORLD TR.	MOLEX	6	562070	562069
C 411	FR JCT BOX-DIODE CONNECTOR	AMP MNL	15	561987	561986	C 476					
C 412	LH DASH PANEL-MASTER SWITCH SW	EATON	8	-----	562763	C 477					
C 413	ENG CPT-A/C HI UNLOAD PRS SW	PED WP	2	561566	561690	C 478	ELECTRONIC DESTINATION SIGN	AMP CPC	9	561636	561637
C 414	RR JCT BOX	AMP MNL	9	561670	561669	C 479	HVAC MODULE				
C 415	ENGINE CRADLE-FAN SIGNAL	PED WP	3	561781	561782	C 480	UNDER DASH LH-DR. FAN SPEED CTR. MOD	PED	4	561889	561890
C 416	ENGINE CRADLE-FAN SIGNAL	PED P-C	3	562237	-----	C 481	UNDER DASH LH-DR. FAN SPEED CTR. MOD	PED	3	561781	561782
C 417	FRONT JCT BOX-DIODES	AMP MNL	15	561987	561986	C 482					
C 418	LH DASH PANEL-HTR WINDSH.SW	EATON	8	-----	562763	C 483	FR SERVICE CPT. (NOT USED)	PED PC	2	-----	562237
C 419	FR JCT BOX-RETARDER OR JACOB	AMP MNL	3	561667	561550	C 484	UNDER DASH LH.-FOOT DAMPER MOTOR	PED PC	2	-----	562076
C 420	ENGINE COMPT. WEBASTO WATER HTR	TC	2	561597	-----	C 485	UNDER DASH LH.-DASH & DEFR. DAM.MOT.	AMP MNL	3	561667	561550
C 421	ENGINE COMPT. WEBASTO WATER HTR	TC	1	561073	-----	C 486					
C 422	ENGINE COMPT. WEBASTO WATER HTR	TC	2	561597	-----	C 487					
C 423						C 488					
C 424	UNDER INSTRUMENT PANEL CENTER	AMP MNL	3	561667	561550	C 489					
C 425	FR JCT BOX-DIODES	AMP MNL	15	561987	561986	C 490					
C 426	ENGINE COMPT. CLUTCH CTR FAN	PED WP	3	561781	561782	C 491					
C 427						C 492					
C 428						C 493					
C 429	FR JCT BOX COMPT.	AMP MNL	6	561552	561515	C 494					
C 430	LH CONSOLE-TIMER	AMP FF	8	561188	562363	C 495					
C 431	LH CONSOLE-PRE HEAT.	TAB AMP	1	561540	561539	C 496					
C 432	ENGINE CPT.-PROX. SW. DOOR AJAR	DEUTSCH	4	562479	562477	C 497					
C 433	FR SERVICE CPT. KNEEL. PRESS. SW	PED WP	2	561566	561690	C 498					
C 434	FRONT JCT. BOX-DIODES	AMP MNL	15	561987	561986	C 499					
C 435	FR SERVICE CPT.(RH) KNEEL. PIEZO	AMP MNL	2	560900	560898	C 500	FR LH UPPER WHELL CPT -PRODRIVER	MOLEX	6	562070	562069
C 436	RH HAT RACK-WCL CENTER ROOF ACC	AMP CPC	16	561639	561640	C 501	FR LH UPPER WHELL CPT -PRODRIVER	PED MP	7	562433	-----
C 437	RH HAT RACK-WCL FR & RR SECT.	AMP CPC	24	561642	561643	C 502	LH DASH PANEL-PRE HEATER SW.	EATON	8	-----	562763
C 438						C 503	LH CONSOLE-PRE HEATER SW.	EATON	2	-----	561837
C 439						C 504	LH CONSOLE WEBASTO TIMER	AMP	8	-----	562852
C 440						C 505	LH CONSOLE ESPAR TIMER	AMP	9	-----	562681
C 441						C 506	FR JCT BOX CPT. DIGITAL CLOCK	AMP	4	561685	561687
C 442						C 507	FR SECT. LH HAT-RACK DIG. CLOCK	MOLEX	4	561477	561476
C 443						C 508	RR JCT BOX-FAN CLUTCH RETARDER	AMP MNL	6	561552	561515
C 444						C 509	FR LH UPPER WHELL CPT -DATA LOGGER	PED MP	16	-----	562530
C 445						C 510	FR LH UPPER WHELL CPT -DATA LOGGER	DEUTSCH	9	562531	-----
C 446						C 511	FR LH UPPER WHELL CPT -DATA LOGGER	PED MP	4	562532	-----
C 447						C 512	FR LH UPPER WHELL CPT -DATA LOGGER	PED MP	10	562533	-----
C 448						C 513	FR LH UPPER WHELL CPT -DATA LOGGER	AMP MNL	3	561667	561550
C 449						C 514	FR LH UPPER WHELL CPT -DATA LOGGER	PED MP	6	562433	562417
C 450	SOUND SYS. JCT. PANEL	MOLEX	4	562507	562503	C 515	FR JCT BOX CPT.-INTERCOM	MOLEX	4	561477	561476
C 451	WIRELESS MICRO-FIRST CPT BAG	MOLEX	2	562550	562549	C 516	FR JCT BOX CPT.-INTERCOM	MOLEX	6	562070	562069
C 452	UNDER DASH INSTR. PANEL	MOLEX	2	562550	562549	C 517	LAVATORY WALL-INTERCOM	MOLEX	6	562070	562069
C 453	SOUND SYS. JCT.PANEL-VCP	PED WP	2	561566	561680	C 519	UNDER DASH RH-SEDAN DOOR	HUMPHREY	2	-----	562580
C 454	SOUND SYS.JCT.PAN.-FILT. VCP	PED WP	2	561566	561680	C 520	UNDER DASH RH-SEDAN DOOR	HUMPHREY	2	-----	641385
C 455	WIRELESS MICRO-LH HAT-RACK	CINCH	2	562554	562551	C 521	UNDER DASH RH-SEDAN DOOR	HUMPHREY	2	-----	641385
C 456	WORLD TRANSM.-RETARDER ACCUM.	PED MP	2	-----	562427	C 522	FR JCT BOX-DAYTIME LTS MODULE	BOSCH	5	-----	561183
C 457	WORLD TRANSM.-MAIN CONNECTOR	DEUTSCH	31	562572	562536	C 523	FR JCT BOX-FUSE BLOCK	PED	8	562647	562646
C 458	WORLD TRANSM.-TURBINE SP.SENS	PED MP	2	-----	562426	C 524	FR JCT BOX-FUSE BLOCK	PED	8	562647	562646



# CONNECTORS CODE

NO	LOCATION	TYPE	CAVITY	#PIN	#SOCKET	NO	LOCATION	TYPE	CAVITY	#PIN	#SOCKET
				HOUSING	HOUSING					HOUSING	HOUSING
C 525	FR JCT BOX-FUSE BLOCK	PED	8	562647	562646	C 592	L.H.CONSOLE - MIRROR R.H.	EURAMTEC	8	-----	562799
C 526	FR JCT BOX-FUSE BLOCK	PED	8	562647	562646	C 593	BATTERY CMPT. - CHARGER	PED WP	3	561781	561782
C 527	FR JCT BOX-FUSE BLOCK	PED	8	562647	562646	C 594	FRONT ROOF - DRIVERS LIGHT	LEEKRAFT		-----	562803
C 528	FR JCT BOX-FUSE BLOCK	PED	8	562647	562646	C 595	DASH CENTER MODULE - OPEN DOOR	MOLEX	4	561477	561476
C 529	FR JCT BOX-12V OUTLET	AMP MNL	2	561247	561248	C 596	DASH CENTER MODULE - CLOSE DOOR	MOLEX	4	561477	561476
C 530	RR JCT BOX-FUSE BLOCK	PED	8	562647	562646	C 597	L.H. DASH PANEL - DISPLAY SET SW.	MOLEX	5		562812
C 531	RR JCT BOX-FUSE BLOCK	PED	8	562647	562646	C 598	L.H. DASH PANEL - DISPLAY SET SW.	MOLEX	5		562812
C 532	RR JCT BOX-FUSE BLOCK	PED	8	562647	562646	C 599					
C 533	RR JCT BOX-FUSE BLOCK	PED	8	562647	562646	C 600	ENGINE CPT.-A/C LOW PRESS SW. UNLOAD	PED	2	562348	562471
C 534	RR JCT BOX-FUSE BLOCK	PED	8	562647	562646	C 601	L.H. ROOF - WINDOW AJAR	AMP MNL	2	561248	561247
C 535	RR JCT BOX-FIRE MODULE DETECT.	AMP MNL	3	561667	561550	C 602	L.H. ROOF - WINDOW AJAR	MOLEX	4	561477	561476
C 536	UNDER DASH RH-DRIVER'S HTR TEMP. CTR	AMP MNL	6	561552	561515	C 603	R.H. ROOF - WINDOW AJAR	AMP MNL	2	561248	561247
C 537	BATT. CPT.-A/C PRESS. SIGN. RLY	AMP MNL	2	561248	561247	C 604					
C 538	FR SERVICE CPT.-OUTSIDE TEMP. SENSOR	AMP MNL	2	561248	561247	C 605	HAT RACK - MOTOR FAN	PED	2	560997	561030
C 539	HVAC DASH MODULE OUTPUT CON	MOLEX	24		562780	C 606	HAT RACK - MOTOR FAN	PED	2	560997	561030
C 540	HVAC DASH MODULE INPUT CON	MOLEX	22		562781	C 607	FRONT SERVICE CMPT. RPM SIGNAL	PED WP	2	561566	561690
C 541	SOUND SYS. JCT PANEL-AUDIO SEAT SYS.	PED WP	2	561566	561690	C 608	FRONT SERVICE CMPT. SPEED SIGNAL	PED WP	2	561566	561690
C 542	LH HAT RACK-AUDIO SEAT SYSTEM	AMP MNL	3	561667	561550	C 609	LAVATORY - NIGHT LIGHT				
C 543	RR JCT BOX-PARK. BRAKE STOP LTS RESIS.	PED WP	2	561566	561690	C 610	RR JCT BOX	AMP MNL	6	561552	561515
C 544	SOUND SYS JCT PANEL-AUDIO SEAT SYS.	PED WP	3	561781	562428	C 611	HAT RACK READING LTS RICON	MOLEX	6	562558	562557
C 545	LH HAT RACK-AUDIO SEAT SYSTEM	AMP MNL	3	561667	561550	C 612	HAT -RACK FLUOR. INSTATION LTS RICON	MOLEX	4	562507	562503
C 546						C 613	HAT -RACK INDIRECT LTS RICON	AMP MNL	3	561667	561550
C 547	RH DASH PANEL-ACCESSORIES	AMP CPC	37	561645	561646	C 614	HAT -RACK INDIRECT LTS RICON	AMP MNL	3	561667	561550
C 548	LH DASH PANEL-T.T. LT. TEST SW.	EATON	8	-----	562763	C 615					
C 549	LH DASH PANEL-FAN CLUTCH OVERR. SW	EATON	8	-----	562763	C 616					
C 550	LAST LUGG. CPT. -WCL RICON	AMP CPC	16	561694	561695	L X	CLUSTER	JAE	22		562766
C 551	LAST LUGG. CPT. -WCL RICON	AMP CPC	16	561694	561695	L Y	CLUSTER	JAE	30		562767
C 552	LAST LUGG. CPT. -WCL RICON	AMP CPC	9	561636	561637	R X	CLUSTER	JAE	22		562764
C 553	UNDER DASH R.H. - CONTROL. HEAD	MOLEX	16	-----	562559						
C 554	UNDER DASH R.H. - CONTROL. HEAD	MOLEX	16	-----	562559						
C 555	UNDER DASH R.H. - CONTROL. HEAD	MOLEX	16	-----	562559						
C 556	UNDER DASH R.H. - RADIO ACC.	MOLEX	2	562550	562549						
C 557	UNDER DASH R.H. - RADIO ACC.	MOLEX	9	562556	562555						
C 558	UNDER DASH R.H. - RADIO ACC.	MOLEX	4	562507	562503						
C 559	L.H. HAT RACK - PASSENGER SPK.	MOLEX	4	562507	562503						
C 560	SOUND SYS. JCT. PANEL - POWER AMPLI	MOLEX	4	562507	562503						
C 561	L.H. HAT RACK - WIRELESS MICRO	MOLEX	4	562507	562503						
C 562	L.H. HAT RACK - VCP	MOLEX	9	562556	562555						
C 563	L.H MODESTY PANEL - DRIVERS SPK.	MOLEX	4	562507	562503						
C 564	L.H MODESTY PANEL - MICRO	MOLEX	4	562507	562503						
C 565	R.H MODESTY PANEL - MICRO	MOLEX	4	562507	562503						
C 566	L.H. CONSOLE - BOOM MICRO	MOLEX	4	562507	562503						
C 567	L.H. CONSOLE - DRIVERS MICRO	MOLEX	4	562507	562503						
C 568	SOUND SYS. JCT. PANEL - PASS. SPK	CINCH	4	562553	562552						
C 569	SOUND SYS. JCT. PANEL - POWER AMPLI.	MOLEX	9	562556	562555						
C 570	UNDER DASH PANEL TTLT	MOLEX	6		562464						
C 571	UNDER DASH PANEL TTLT	MOLEX	20		562778						
C 572	UNDER DASH PANEL TTLT	MOLEX	18		562779						
C 573	UNDER DASH PANEL TTLT	MOLEX	16		562465						
C 574	HAT -RACK FLUOR. INDIRECT LIGHTING	MOLEX	6	-----	562759						
C 575	HAT -RACK FLUOR. INSTATION LIGHT	MOLEX	4	562507	562503						
C 576	HAT -RACK FLUOR. INDIRECT LIGHTING	AMP MNL	3	561667	561550						
C 577	HAT -RACK FLUOR. INDIRECT LIGHTING	AMP MNL	3	561667	561550						
C 578	HAT -RACK FLUOR. INSTATION LIGHT	MOLEX	4	562507	562503						
C 579											
C 580	RH DASH PANEL-HAT RACK FAN SW	EATON	8	-----	562763						
C 581											
C 582	FRONT SERVICE CMPT. - WINDOWS AJAR	PED WP	2	561566	561690						
C 583	L.H. DASH PANEL - MASTER KEY	DEUTSCH	2	562486	562485						
C 584	FRONT SERVICE CMPT. - AIR HORH	HUMPHREY	3	-----	641385						
C 585											
C 586											
C 587											
C 588	FRONT SERVICE CPT. CENTER SOUND SYS.	AMP. CPC	37	561645	561646						
C 589	UNDER DASH - L.H. MIRROR	AMP MNL	9	561670	561669						
C 590	UNDER DASH - R.H. MIRROR	AMP MNL	9	561670	561669						
C 591	L.H.CONSOLE - MIRROR L.H.	EURAMTEC	8	-----	562799						



# CONNECTORS CODE

NO	LOCATION	TYPE	CAVITY	#PIN	#SOCKET	NO	LOCATION	TYPE	CAVITY	#PIN	#SOCKET
				HOUSING	HOUSING					HOUSING	HOUSING
C AA1	BEHIND DASH - SONALERT	BOSCH	5		561183	C 57					
C AA2	BEHIND DASH - SONALERT	BOSCH	5		561183	C 58	RR JCT BOX AC PANEL	DEUTSCH	24	562280	562283
C X1	FR LH UPPER WHELL CPT-ABS	WABCO	18		562792	C 59	RR JCT BOX AC PANEL	AMP CPC	14	561584	561583
C X2	FR LH UPPER WHELL CPT-ABS	WABCO	6		562793	C 60	RR JCT BOX COMPT.-LT	AMP MNL	2	561248	561247
C X3	FR LH UPPER WHELL CPT-ABS	WABCO	9		562794	C 61	LUGGAGE COMPARTMENT LTS	AMP MNL	2	561248	561247
C X4	FR LH UPPER WHELL CPT-ABS	WABCO	15		562795	C 62	LUGGAGE COMPARTMENT LTS	AMP MNL	2	561248	561247
CS	RR JCT BOX ECU WORLD TR.	PED	32		562817	C 63	LUGGAGE COMPARTMENT LTS	AMP MNL	2	561248	561247
CT	RR JCT BOX ECU WORLD TR.	PED	32		562824	C 64	LUGGAGE COMPARTMENT LTS	AMP MNL	2	561248	561247
CV	RR JCT BOX ECU WORLD TR.	PED	32		562823	C 65	LUGGAGE COMPARTMENT LTS	AMP MNL	2	561248	561247
CV 12	RR JCT BOX-WORLD TRANSM. & EATON CLUSTER	AMP CPC	9	561636	561637	C 66	LUGGAGE COMPARTMENT LTS	AMP MNL	2	561248	561247
C Y		JAE	30		562765	C 67	LUGGAGE COMPARTMENT LTS	AMP MNL	2	561248	561247
C 1	FR JCT BOX COMPARTMENT	AMP CPC	14	561585	561584	C 68	LUGGAGE COMPARTMENT LTS	AMP MNL	2	561248	561247
C 2	FR JCT BOX COMPARTMENT	AMP CPC	16	561639	561640	C 69	RR AXLE ACC-INSIDE PVC END	PED WP	6	561568	561578
C 3	FR JCT BOX COMPARTMENT	AMP CPC	24	561641	561643	C 70	LH CONSOLE	AMP CPC	16	561642	561643
C 4	FR JCT BOX COMPARTMENT	AMP CPC	37	561644	561646	C 71	FR JCT BOX COMPARTMENT	AMP CPC	37	561645	561646
C 5	FR SERVICE COMPT.-UNDERNEATH	AMP CPC	37	561644	561646	C 72	FR JCT BOX COMPARTMENT	AMP CPC	24	561642	561643
C 6	FR SERVICE COMPT.-UNDERNEATH	AMP CPC	16	561639	561640	C 73	DASH CENTER PANEL	AMP CPC	16	561639	561640
C 7						C 74	FR JCT BOX COMPARTMENT	AMP CPC	37	561645	561646
C 8	FR SERVICE COMPT.-UNDERNEATH	AMP CPC	24	561641	561643	C 75					
C 9	FR SERVICE COMPT.-UNDERNEATH	AMP CPC	24	561641	561643	C 76	LUGGAGE COMPT.-AIR RET.SENS.	AMP MNL	2	561248	561247
C 10						C 77	LUGGAGE COMPT.-AIR RET.SENS.	AMP MNL	2	561248	561247
C 11	FR SERVICE COMPARTMENT	AMP CPC	37	561644	561646	C 78					
C 12	FR SERVICE COMPARTMENT	AMP CPC	16	561639	561640	C 79					
C 13	LH CONSOLE-CTR MIRROR	AMP MNL	6	561552	561515	C 80	LUGGAGE COMPT.-AIR RET.SENS.	AMP MNL	2	561248	561247
C 14	UNDER DASH-LH MIRROR	AMP MNL	9	561661	561662	C 81	PASSENGER COMPT.-AISLE LTS	AMP MNL	2	560900	560898
C 15	RR JCT BOX	AMP CPC	24	561641	561643	C 82	ENTRANCE DOOR	MOLEX	6	562070	562069
C 16	LH CONSOLE SW-CRUISE ON OFF	EATON	10	-----	562763	C 83	ENTRANCE DOOR-PROIMITY SW	MOLEX	4	561477	561476
C 17	LH CONSOLE SW-CRUISE RESUME	EATON	10	-----	562763	C 84	ENTRANCE DOOR-PRESSURE SW	PED WP	2	561566	561690
C 18	LH CONSOLE SW-CRUISE SET	EATON	10	-----	562763	C 85	UNDER INSTRUMENT PANEL LH	AMP MTA-100	-----	562248	-----
C 19	LH CONSOLE DECEL SW	EATON	10	-----	562763	C 86					
C 20	RR JCT BOX	AMP CPC	37	561644	561646	C 87	RR END ROOF	AMP CPC	9	561636	561637
C 21	RR JCT BOX	AMP CPC	24	561641	561643	C 88	RR END ROOF-CLEARANCE LTS	AMP MNL	2	560900	560898
C 22	RR JCT BOX - EATON TRANSM.	AMP MNL	6	561552	561515	C 89	RR END ROOF-B/U NONITOR	AMP CPC	4	561582	561581
C 23	DDEC ENGINE-ECM J1939	PED MP	6	-----	561962	C 90	RR JCT BOX	AMP CPC	15	561987	561986
C 24	DDEC ENGINE	PED WP	1	561605	561577	C 91	RR JCT BOX	AMP CPC	37	561714	561713
C 25	RR JCT BOX - EATON TRANSM. J1939	DEUTCH	3	562877	562884	C 92	FR LH UPPER WHELL CPT-ABS	AMP CPC	9	561635	561637
C 26	HYD & MAN TRANSM.-NEUT. & B/U	PED WP	4	561610	561611	C 93	FR LH UPPER WHELL CPT-ABS		35	-----	641094
C 27	HYD & MAN TRANSM.-SPEED SENS.	PED WP	2	561566	561690	C 94					
C 28	EATON TRANSMISSION	DEUTCH	3	562877	562884	C 95	CONDENSOR CPT - LIQ. SOL. VALVE	PED WP	2	561566	561690
C 29	EATON TRANSMISSION	PED MP	6	562878	-----	C 96	FR AXLE ACCESSORIES	AMP CPC	14	561585	561585
C 30	RR JCT BOX - ECU EATON TRANSM.	PED MP	32	-----	562866	C 97	RR AXLE ACC-INSIDE PVC END	PED WP	6	561568	561578
C 31	RR JCT BOX - ECU EATON TRANSM.	PED MP	24	-----	562865	C 98	FR SERVICE COMPT-EL.FT.PEDAL	PED WP	3	561782	561781
C 32	DDEC ENGINE-ECM	PED	30	-----	561600	C 99	FR SERVICE COMPT LTS	AMP MNL	2	561248	561247
C 33	RR JCT BOX - EATON TRANSM.	DEUTCH	9	562531	-----	C 100	LH CONSOLE - 120 VOLTS SWITCH	EATON	8	-----	562763
C 34	RH. CONSOLE - EATON TRANSM. SHIFTER	PED MP	3	-----	562871	C 101	FR SERVICE COMPT-ELEC. HORNS	PED WP	2	561566	561690
C 35	RR JCT BOX	AMP CPC	24	561642	561643	C 102	FR SERV & SIDE CPT-FLASH. LH	GROTE	2	-----	562155
C 36	RH. CONSOLE - EATON TRANSM. SHIFTER	PED MP	24	-----	562874	C 103	FR SERV & SIDE CPT-MARKERS	GROTE	2	-----	562155
C 37	RR SECTION-LH HAT RACK	MOLEX	6	562558	562557	C 104	FR SERV & SIDE CPT-FLASH. RH	GROTE	2	-----	562155
C 38	RR SECTION-RH HAT RACK	MOLEX	6	562558	562557	C 105	FR SERVICE COMPT-LIQ.S.VALVE	PED WP	2	561566	561690
C 39	LH CONSOLE - EATON TRANSM. DISPLAY	AMP MNL	4	561551	561668	C 106	FR SERVICE COMPT-WATER VALVE	PED WP	2	561566	561690
C 40	RR JCT BOX - EATON TRANSM. J1939	DEUTCH	3	562877	562884	C 107	EVAPORATOR COMPT-DAMPER	PED WP	2	561566	561690
C 41	LAVATORY ROOF FLUORESCENT	AMP MNL	2	560900	560898	C 108	FR SERVICE COMPT-KNEEL.SYS	PED WP	2	561566	561690
C 42	LAVATORY BACK WALL-WTR TANK	AMP MNL	2	560900	560898	C 109	FR SERVICE COMPT-KNEEL.SYS	PED WP	2	561566	561690
C 43	LAVATORY BACK WALL-ACCES.	AMP MNL	9	561661	561662	C 110	FR SERVICE COMPT-KNEEL.SYS	PED WP	2	561566	561690
C 44	EATON TRANSM. J1939	DEUTCH	3	562877	562884	C 111	EVAPORATOR COMPT-DAMPER	DEUTSCH	2	562486	562485
C 45	FR JCT BOX COMPARTMENT	AMP CPC	24	561642	561643	C 112	EVAPORATOR COMPT-SPEED MOT CTRL	DEUTSCH	5	-----	562566
C 46	EATON TRANSM. J1939	DEUTCH	3	562877	562884	C 113	BATT. & RR J.B.CPT.MARKER LT	GROTE	2	-----	562155
C 47	FR SERVICE COMPARTMENT	AMP CPC	16	561694	561695	C 114	RR J. BOX CPT DOOR DIR LT LH	GROTE	2	-----	562155
C 48						C 115	ENGINE COMPT-AIR DRYER	PED WP	2	561566	561690
C 49	BATTERIE COMPT.-LT	AMP MNL	2	561248	561247	C 116	ENGINE COMPT. LTS	PED WP	1	561605	561577
C 50	FR SERVICE COMPT.-LOW BUOY	PED WP	1	561605	561577	C 117					
C 51						C 118	ENGINE COMPT-LAVATORY FAN	PED WP	2	561566	561690
C 52	RR JCT BOX	AMP CPC	22	561709	561710	C 119	ENGINE CPT RR DOOR RH LO LAMP	PED WP	6	561606	561607
C 53						C 120	ENGINE CPT RR DOOR LH LO LAMP	PED WP	6	561606	561607
C 54						C 121	BATTERIE CPT. DOOR DIR LT RH	GROTE	2	-----	562155
C 55	RH SWITCH PANEL	AMP CPC	9	561636	561637	C 122	ENGINE CPT-UNLOAD TAG SYSTEM	PED WP	2	561566	561690
C 56						C 123	TAG AXLE-UNLOAD TAG RH VALVE	PED WP	2	561566	561690

# CONNECTORS CODE

NO	LOCATION	TYPE	CAVITY	#PIN	#SOCKET	NO	LOCATION	TYPE	CAVITY	#PIN	#SOCKET
				HOUSING	HOUSING					HOUSING	HOUSING
C 124	ENGINE CPT-ETHER SW	PED WP	2	561566	561690	C 189	ENGINE CPT RR DOOR B/U LT	PED WP	2	561566	561690
C 125	ENGINE CPT-BU ALARM	PED WP	2	561566	561690	C 190	ENGINE CPT RR DOOR TAIL LT	PED WP	2	561566	561690
C 126	ENGINE CPT-FLUSHING PUMP	PED WP	2	561566	561690	C 191	ENGINE CPT RR DOOR RH STOP LT	PED WP	2	561566	561690
C 127	ENGINE CPT-FUEL FILTER	PED WP	2	561566	561690	C 192	ENGINE CPT RR DOOR RH DIR. LT	PED WP	2	561566	561690
C 128	ENGINE CPT-A/C COMPR.CLUTCH	ITT SS	2	561813	561812	C 193					
C 129	ENGINE CPT-PRE-HEAT WATER	AMP FF	6	561672	561186	C 194	ENGINE CPT RR DOOR LH DIR. LT	PED WP	2	561566	561690
C 130	ENGINE CPT-UNLOADER	ITT SS	2	561813	561812	C 195	ENGINE CPT RR DOOR LH STOP LT	PED WP	2	561566	561690
C 131	ENGINE CPT-UNLOADER	ITT SS	2	561813	561812	C 196	ENGINE CPT RR DOOR CYCLOP LT	PED WP	2	561566	561690
C 132	ENGINE CPT-A/C LO PRESS SW	PED WP	2	561566	561690	C 199	ENGINE CPT RR DOOR LICENCE LT	DOM AUTO	2	930210	-----
C 133	ENGINE CPT-A/C HI PRESS SW	PED WP	2	561566	561690	C 200	RH HAT RACK-FLUORESCENT	AMP MNL	2	561248	561247
C 134	FR JCT BOX-LUGGAGE DIODE CON.	AMP MNL	15	561987	561986	C 201	RH HAT RACK-FLUORESCENT	AMP MNL	2	561248	561247
C 135	FR JCT BOX-LUGGAGE DIODE CON.	AMP MNL	15	561987	561986	C 202	RH HAT RACK-INDIRECT LIGHTING	MOLEX	2	-----	562758
C 136	RR JCT BOX - A/C PANEL DIODE CONN.	AMP MNL	15	561987	561986	C 203	RH HAT RACK-INDIRECT LIGHTING	MOLEX	6	-----	562759
C 137	RR JCT BOX-TRANSMITTER	AMP MNL	2	560900	560898	C 204	RH HAT RACK-GENERAL LT	AMP MNL	2	560900	560898
C 138	RR JCT BOX-CONTROL MODULE	AMP HDP	15	-----	562012	C 205	FR SECT.-RH HAT RACK SPEAKER	AMP MNL	9	561661	561662
C 139	RR JCT BOX-LOGIC MODULE	AMP HDP	15	562011	-----	C 206	RH HAT RACK-READING LT	AMP FF	4	-----	562756
C 140	HVAC DASH MODULE THERMOMETER	MOLEX	4		562782	C 207	LH HAT RACK-READING LT	AMP FF	4	-----	562756
C 141	INSTRUMENT PANEL LH UNLOAD TAG	AMP	2	561248	561247	C 208	LH HAT RACK-BALLAST	MOLEX	2	-----	562758
C 142	LAVATORY DOOR WALL	AMP MNL	2	561248	561247	C 209	LH HAT RACK HOTESS CHIME	AMP MNL	3	561667	561550
C 143	LAVATORY DOOR WALL	AMP MNL	3	560908	562006	C 210	FR SECT.-LH HAT RACK SPEAKER	AMP MNL	9	561661	561662
C 144	UNDER LH SEAT-AISLE LTS	AMP MNL	4	560851	560852	C 211	FR ROOF-STORE LH	AMP MNL	2	560900	560898
C 145	RR JCT BOX CPT-RR SIDE LTS	AMP MNL	9	561670	561669	C 212	FR ROOF-STORE RH	AMP MNL	2	560900	560898
C 146	ENGINE CPT-MODULATOR VALVE	AMPHENOL	2	-----	560412	C 213	FR ROOF-CLEARANCE LT	AMP MNL	2	560900	560898
C 147	BATT & RR J.B.CPT-DOCK.LTS	PED WP	2	561566	561690	C 214	ENGINE CPT J1922				
C 148						C 215	TAG AXLE - A.T.C. SYSTEM				
C 149	CONDENSER CPT-FAN MOTOR	ORDNANCE	3	562555	562001	C 216	TAG AXLE - A.T.C. SYSTEM				
C 150						C 217	RH DASH PANEL-FRONT CAMERA SW	EATON	8	-----	562763
C 151	EVAPORATOR CPT-THERMOSTAT	ITT SS	2	561813	562159	C 218	RH DASH PANEL-FRONT CAMERA SW	AMP MNL	2	560900	560898
C 152	CONDENSER CPT-FUEL GAUGE	PED WP	4	561610	561611	C 219					
C 153	EVAPORATOR CPT-AIR AMB. SENS	AMP MNL	2	561248	561247	C 220	RR.JCT.BOX-FUEL PRIME PUMP	TC	1	561070	561073
C 154	EVAPORATOR CPT-FRESH AIR SENS	ITT SS	2	561813	561812	C 221					
C 155	EVAPORATOR CPT-WATER VALVE	PED WP	4	561610	561611	C 222					
C 156	EVAPOR. CPT-BYPASS WATER VAL.	PED WP	2	561566	561690	C 223					
C 157	EVAPORATOR CPT-WATER PUMP	PED WP	2	561566	561690	C 224					
C 158	CONDENSER CPT-A/C LO TEMP.	PED WP	2	561566	561690	C 225					
C 159	CONDENSER CPT-A/C HI TEMP.	PED WP	2	561566	561690	C 226					
C 160	FR AXLE-ABS RH SENSOR	WABCO	2	641132	-----	C 227					
C 161	FR AXLE-ABS RH VALVE	WABCO	3	-----	641098	C 228					
C 162	FR AXLE-ABS LH VALVE	WABCO	3	-----	641098	C 229					
C 163	FR AXLE-ABS LH SENSOR	WABCO	2	641132	-----	C 230	ENG.CPT.-FUEL PRIME PUMP FEED	DEUTSCH	2	562486	562485
C 164	RR AXLE-ABS LH SENSOR	WABCO	2	641132	-----	C 231	ENG.CPT.-FUEL PRIME PUMP SW.	PED WP	2	561566	561690
C 165	RR AXLE-ABS LH VALVE	WABCO	3	-----	641098	C 232	ENG.CPT.-FUEL PRIME PUMP	PED WP	2	561566	561690
C 166	RR AXLE-ABS RH VALVE	WABCO	3	-----	641098	C 233	FR. SERVICE COMPT.	VDO	8	-----	562043
C 167	RR AXLE-ABS RH SENSOR	DEUTSCH	2	641132	-----	C 234	FR. SERVICE COMPT.	VDO	8	-----	562044
C 168	RR AXLE-ABS OPT ATC	PED WP	2	561566	561690	C 235	FR. SERVICE COMPT.	VDO	8	-----	562041
C 169	RR JCT BOX-SPEED SW	AMP HDP	15	-----	562012	C 236	LUGGAGE COMPARTEMENT	AMP MNL	4	560851	560852
C 170	FR JCT BOX-FLASHER UNIT	TC	2	-----	561940	C 237	UNDER DASH LH-JACOB CLUTCH SW	ITT SS	3	561111	561080
C 171	LH CONSOLE	AMP CPC	24	561642	561643	C 238	RR JCT BOX-DIODE CONNECTOR	AMP MNL	9	561670	561669
C 172	ENGINE COMPT-WATER TANK HEAT.	PED WP	2	561566	561690	C 239	FR SERVICE CPT-HI BUOY VALVE	PED WP	2	561566	561690
C 173	LAV.POTABLE-WATER TANK HEAT.	AMP MNL	2	560900	560898	C 240	FR SERVICE CPT-KNEEL PROX SW	PED WP	2	561566	561690
C 174	UNDER DASH RH-HTR MODULE	AMP MNL	9	561670	561669	C 241					
C 175	UNDER DASH RH-HTR MODULE	AMP MNL	9	561670	561669	C 242	FR SERVICE CPT-MARK & DIR LT	ITT SS	3	561111	561080
C 176	UNDER DASH RH-WIPER PULSE	AMP FF	6	-----	561186	C 243	FR SERVICE CPT-HEADLAMPS	TC	3	-----	561071
C 177	UNDER DASH RH-WIPER MOTOR	AMP FF	6	-----	561186	C 244	FR SERVICE CPT-LH FOG LAMP	ITT SS	2	561813	561812
C 178	UNDER DASH RH-LH FAN	TC	2	561030	560997	C 245	FR SERVICE CPT-RH FOG LAMP	ITT SS	2	561813	561812
C 179	UNDER DASH RH-RH FAN	TC	2	561030	560997	C 246	FR SERVICE CPT-MARK & DIR LT	ITT SS	3	561111	561080
C 180	RR JCT BOX-DIODE CONNECTOR	AMP MNL	15	561987	561986	C 247					
C 181	RR JCT BOX-DIODE CONNECTOR	AMP MNL	15	561987	561986	C 248	FR JCT BOX-WIPER PULSE GEN	AMP FF	6	-----	561108
C 182						C 249					
C 183	FR SERVICE CPT-KNEELING PAN.	PED WP	4	561610	561611	C 250					
C 184	FR SERVICE CPT-KNEELING SW	ITT SS	3	561111	561080	C 251	LH DASH PANEL-FAST IDLE SW	EATON	8	-----	562763
C 185						C 252					
C 186	RR JCT BOX CPT.-SPEED SIGN.TR	PED WP	2	561566	561690	C 253	LH DASH PANEL-ETHER SW	EATON	8	-----	562763
C 186M	RR JCT BOX CPT.-SPD SIGN. M.TR	PED WP	2	561566	561690	C 254	INST. PANEL RH-ENTR.DOOR SW.	TORRIX	5	-----	562110
C 186W	RR JCT BOX CPT.-SPD SIGN. WT	PED WP	2	561566	561690	C 255	LH DASH PANEL-JACOB & RETARDER SW	EATON	8	-----	562763
C 187	FR JCT BOX-RPM RESISTOR CON.	AMP MNL	6	561552	561515	C 256					
C 188						C 257					

# CONNECTORS CODE

NO	LOCATION	TYPE	CAVITY	#PIN	#SOCKET	NO	LOCATION	TYPE	CAVITY	#PIN	#SOCKET
				HOUSING	HOUSING					HOUSING	HOUSING
C 258	LH SW PANEL-MULTI FUNC. SW	AMP FF	8	561188	-----	C 325	LH DASH PANEL-KNEELING SW	EATON	8	-----	562763
C 259	LH SW PANEL-MULTI FUNC. SW	AMP FF	6	-----	561108	C 326	LH CONSOLE SW-SPARE	EATON	8	-----	562763
C 260	FR SERVICE CPT-LUG DOOR LCK	PED WP	6	561606	561607	C 327	ENGINE CONTROL	DEUTSCH	6	562583	562581
C 261	UNDER DASH RH-DOOR MODULE	AMP MNL	9	561670	561669	C 328	GALLEY-LAMP	AMP MNL	2	561248	561247
C 262	UNDER DASH RH-DOOR MODULE	AMP MNL	4	561551	561668	C 329	ENGINE TACHO SIGNAL	PED WP	3	561781	561789
C 263	UNDER DASH RH-DOOR MODULE	AMP MNL	3	561667	561550	C 330					
C 264	UNDER DASH RH-DOOR MODULE	AMP MNL	3	561667	561550	C 331	GALLEY MICROWAVE SW	EATON	8	-----	562763
C 265	UNDER DASH RH-DOOR MODULE	AMP HDP-20	15	562011	562012	C 332					
C 266						C 333	GALLEY RH CONTAINER SW	EATON	8	-----	562763
C 267	UNDER DASH RH	AMP CPC	24	561642	561643	C 334	GALLEY LH CONTAINER SW	EATON	8	-----	562763
C 268	UNDER DASH LH-MIRROR	AMP MNL	6	561552	561515	C 335					
C 269	UNDER DASH RH-MIRROR	AMP MNL	6	561552	561515	C 336					
C 270	LH MIRROR POST	MOLEX	6	562070	562069	C 337	INSTR PANEL LH-UP WIPER SW	EATON	8	-----	562763
C 271	RH MIRROR POST	MOLEX	6	562070	562069	C 338	INSTR PANEL LH-UP DEFROST SW	EATON	8	-----	562763
C 272	LH MIRROR	SPARTAN	6	-----	990158	C 339	INSTR PANEL LH-UP WASHER SW	EATON	8	-----	562763
C 273	RH MIRROR	SPARTAN	6	-----	990158	C 340	FR JCT. BOX FIRE PIEZO ALARM	AMP MNL	2	560900	560898
C 274	RR. JCT. BOX - SIGNAL ALT. MODULE					C 341	INSTR PANEL LH-HEAT MIRROR SW	EATON	8	-----	562763
C 275	UNDER DASH RH-DOOR MODULE	AMP MNL	9	561670	561669	C 342	ENGINE RR START SW	DEUTSCH	2	562586	562585
C 276	UNDER DASH RH-LOCK SOL.VALVE	AMP MNL	2	561248	561247	C 343	INSTR PANEL LH-HEADLAMP SW	EATON	8	-----	562763
C 277						C 344	INSTR PANEL LH-HAZARD LT SW	EATON	8	-----	562763
C 278						C 345	INSTR PANEL LH-FOG LT SW	EATON	8	-----	562763
C 279	UNDER DASH CYLINDER READ SW.	AMP MNL	2	561248	561247	C 346					
C 280	LH CONSOLE-UNLOAD TAG SW.	NGR	10	-----	562763	C 347	INSTR PANEL LH-DASH LT SW	AMP MNL	2	560900	560898
C 281						C 348	INSTR PANEL CENT-RACOR MODULE	MOLEX	6	562070	562067
C 282						C 349					
C 283						C 350	RH CONSOLE-THERMOMETER	AMP MNL	3	561667	561550
C 284						C 351	LH HAT RACK-FLUOR 110V	MOLEX	4	561477	561476
C 285						C 352	RH CONSOLE-DRV TEMP SENSOR	BURNDY	4	-----	561104
C 286	RH SW PANEL-A/C & HEAT	EATON	8	-----	562763	C 353	INSTR PANEL RH-DRV FAN RHEOST	AMP MNL	6	561552	561515
C 287	ENGINE COMPT-LTS SW	PED WP	2	561566	561690	C 354	INSTR PANEL RH-DRV TEMP CTR	AMP MNL	6	561552	561515
C 288	RH SW PANEL-FRESH AIR	EATON	8	-----	562763	C 355	INSTR PANEL RH-FR TEMP CTR	AMP MNL	3	561667	561550
C 289						C 356					
C 290						C 357	INSTR PANEL RH-WATER TEMP GA	AMP MNL	3	561667	561550
C 291						C 358	INSTR PANEL RH-FUEL LEVEL GA	AMP MNL	3	561667	561550
C 292						C 359					
C 293						C 360					
C 294						C 361	FR ROOF-WIPER MOTOR	AMP FF	6	-----	561186
C 295						C 362	FR ROOF-LAVATORY OCCUPIED LT	AMP MNL	2	561248	561247
C 296						C 363	FR ROOF-WATCH YOUR STEP LT	AMP MNL	2	561248	561247
C 297	INSTRUMENT PANEL RH -LTS	AMP MNL	2	560900	560898	C 364	FR ROOF-DESTINATION SIGN	AMP MNL	3	561667	561550
C 298						C 365	FR ROOF-UP WINDSHIELD DEFROST	AMP MNL	3	561667	561550
C 299	RH DASH PANEL SW-GALLEY	EATON	8	-----	562763	C 366	RH DASH PANEL-GRN & RED LEDS	AMP MNL	3	560908	562006
C 300						C 367	ENGINE COMPT-DIF OIL T SENSOR	PED WP	2	561566	561690
C 301						C 368	FR ROOF-DEST. SIGN BALLAST	AMP MNL	3	561667	561550
C 302						C 369	FR ROOF-DEST. SIGN OPER. SW	TORRIX	5	-----	562110
C 303						C 370	FR ROOF-DEST. SIGN FLUOR.	AMP MNL	2	560900	560898
C 304						C 371	FR ROOF-DEST. SIGN FLUOR.	AMP MNL	2	560900	560898
C 305						C 372	FR ROOF-DEST. SIGN SPEED SW	MOLEX	4	561477	561476
C 306						C 373	FR ROOF-NO SMOKING LT	AMP MNL	2	561248	561247
C 307						C 374	LH SWITCH PANEL	AMP MNL	6	561552	561515
C 308	LH CONSOLE SW-RHEOSTAT	TC	2	561030	560997	C 375					
C 309	DDEC ENGINE-ECM POWER CON.	PED MP	5	-----	562345	C 376					
C 310	LH DASH PANEL -LUG. DOOR LCK SW	EATON	8	-----	562763	C 377	LH DASH PANEL-STOP ENG.OVERRIDE SW	EATON	8	-----	562763
C 311	RH DASH PANEL -HOS & PAS CHIME SW	EATON	8	-----	562763	C 378					
C 312	RH DASH PANEL -READING LTS SW	EATON	8	-----	562763	C 379					
C 313	RH DASH PANEL -GEN & FLUOR LTS SW	EATON	8	-----	562763	C 380	LH CONSOLE-DDR CONNECTOR	DEUTSCH	6	562360	-----
C 314	LH DASH PANEL-FR DEST. SIGN SW	EATON	8	-----	562763	C 381					
C 315	LH DASH PANEL-LH STORE SW	EATON	8	-----	562763	C 382					
C 316	LH CONSOLE SPARE SWITCH	EATON	8	-----	562763	C 383					
C 317	LH DASH PANEL-RH STORE SW	EATON	8	-----	562763	C 384					
C 318	LH CONSOLE SW-DRV WINDOW LIFT	EATON	8	-----	562763	C 385					
C 319						C 386	LH DASH PANEL-WCL POWER SYSTEM SW	EATON	8	-----	562763
C 320	RH DASH PANEL-DRIVER'S LTS SW	EATON	8	-----	562763	C 387	RR JCT BOX (WCL)	AMP MNL	9	561661	561662
C 321						C 388	RR JCT BOX (WCL)	AMP MNL	12	561735	561734
C 322	LH CONSOLE DRV WIND LIFT MOT	PED PO	2	-----	561848	C 389	WCL REAR DOOR	MOLEX	4	561477	561476
C 323	LH CONSOLE CRUISE CTR SW PAN. AMP	CPC	9	561636	561637	C 390	LAVATORY WALL-WCL REMOTE CTR	EATON	8	-----	562763
C 324						C 391	LAVATORY WALL-WCL LAMP	EATON	8	-----	562763

# CONNECTORS CODE

NO	LOCATION	TYPE	CAVITY	#PIN	#SOCKET	NO	LOCATION	TYPE	CAVITY	#PIN	#SOCKET
				HOUSING	HOUSING					HOUSING	HOUSING
C 392	LAVATORY WALL-WCL SW. LT.	EATON	2	-----	561835	C 459	WORLD TRANSM.-ENGINE SP.SENS.	PED MP	2	-----	562426
C 393	LAVATORY WALL-WCL REMOTE SYS.	AMP CPC	4	561686	561687	C 460	WORLD TRANSM.-SPEED SENSOR	ITT	2	-----	562541
C 394	UNDER INSTR. PANEL- B/U MONITOR	AMP MNL	4	560851	560852	C 461	WORLD TRANSM.-RETARDER TEMP.	PED MP	2	561566	561680
C 395	DRIVER'S COMPT. - B/U MONITOR	AMP	5	-----	-----	C 462	WORLD TRANSM.-RETARD SOL."K"	PED MP	2	-----	562426
C 396	FR SECT. LH HAT RACK-SPEAKER	MOLEX	4	562507	562503	C 463	WORLD TRANSM.-SENSOR CONN.	DEUTSCH	16	562570	562571
C 397	ENGINE COMPT. CRADLE ACC.	DEUTSCH	40	562281	562284	C 464	RR JCT BOX-DDR CONNECTOR	DEUTSCH	6	-----	562360
C 398						C 465	LH CONSOLE-SHIFTER SELECTOR	PED	20	-----	562825
C 399	ENGINE COMPT. - PRE-EXITATION ALT.	PED WP	2	561566	561690	C 466	FR SERVICE CPT.-RESIS. MOD.	PED WP	3	-----	562428
C 400	ENGINE COMPT. BLOCK HEATER	PED MP	3	561781	561782	C 467	FR SERVICE CPT.-RESIS. MOD.	PED WP	3	-----	562428
C 401						C 468			8		
C 402	RR DRIVE AXLE-AIR DRYER	PED MP	2	-----	562251	C 469					
C 403	GALLEY FRIGO NORCOLD	AMP MNL	2	561248	561247	C 470	FR LH UPPER WHELL CPT-SILENT 1000	AMP MNL	2	561248	561247
C 404	GALLEY LAMP	AMP MNL	2	561248	561247	C 471	FR LH UPPER WHELL CPT-SILENT 1000	AMP MNL	2	561248	561247
C 405						C 472	FR LH UPPER WHELL CPT-SILENT 1000	PED WP	2	561566	561690
C 406	FR JCT BOX COMPT.-ABS	AMP MNL	2	560900	560898	C 473	FR LH UPPER WHELL CPT-SILENT 1000	AMP MNL	3	561667	561550
C 407	ENGINE COMPT. -SIGNAL	PED WP	6	561606	561607	C 474	DRIVER CPT.-TEMP. SENSOR	AMP MNL	2	561247	561248
C 408	ENGINE COMPT. -SIGNAL	PED WP	6	561606	561607	C 475	RR JCT BOX-SPEED SIGN CONNECTOR	AMP MNL	2	561248	561247
C 409	ENGINE CPT -LOW COOL. LEVEL	PED MP	2	-----	562350	C 475M	RR JCT BOX-SPEED SIGN MANUAL TR.	MOLEX	6	562070	562069
C 410	FR JCT BOX-DIODE CONNECTOR	AMP MNL	15	561987	561986	C 475W	RR JCT BOX-SPEED SIGN WORLD TR.	MOLEX	6	562070	562069
C 411	FR JCT BOX-DIODE CONNECTOR	AMP MNL	15	561987	561986	C 476					
C 412	LH DASH PANEL-MASTER SWITCH SW	EATON	8	-----	562763	C 477					
C 413	ENG CPT-A/C HI UNLOAD PRS SW	PED WP	2	561566	561690	C 478	ELECTRONIC DESTINATION SIGN	AMP CPC	9	561636	561637
C 414	RR JCT BOX	AMP MNL	9	561670	561669	C 479	HVAC MODULE				
C 415	ENGINE CRADLE-FAN SIGNAL	PED WP	3	561781	561782	C 480	UNDER DASH LH-DR. FAN SPEED CTR. MOD	PED	4	561889	561890
C 416	ENGINE CRADLE-FAN SIGNAL	PED P-C	3	562237	-----	C 481	UNDER DASH LH-DR. FAN SPEED CTR. MOD	PED	3	561781	561782
C 417	FRONT JCT BOX-DIODES	AMP MNL	15	561987	561986	C 482					
C 418	LH DASH PANEL-HTR WINDSH.SW	EATON	8	-----	562763	C 483	FR SERVICE CPT. (NOT USED)	PED PC	2	-----	562237
C 419	FR JCT BOX-RETARDER OR JACOB	AMP MNL	3	561667	561550	C 484	UNDER DASH LH.-FOOT DAMPER MOTOR	PED PC	2	-----	562076
C 420	ENGINE COMPT. WEBASTO WATER HTR	TC	2	561597	-----	C 485	UNDER DASH LH.-DASH & DEFR. DAM.MOT.	AMP MNL	3	561667	561550
C 421	ENGINE COMPT. WEBASTO WATER HTR	TC	1	561073	-----	C 486					
C 422	ENGINE COMPT. WEBASTO WATER HTR	TC	2	561597	-----	C 487					
C 423						C 488					
C 424	UNDER INSTRUMENT PANEL CENTER	AMP MNL	3	561667	561550	C 489					
C 425	FR JCT BOX-DIODES	AMP MNL	15	561987	561986	C 490					
C 426	ENGINE COMPT. CLUTCH CTR FAN	PED WP	3	561781	561782	C 491					
C 427						C 492					
C 428						C 493					
C 429	FR JCT BOX COMPT.	AMP MNL	6	561552	561515	C 494					
C 430	LH CONSOLE-TIMER	AMP FF	8	561188	562363	C 495					
C 431	LH CONSOLE-PRE HEAT.	TAB AMP	1	561540	561539	C 496					
C 432	ENGINE CPT.-PROX. SW. DOOR AJAR	DEUTSCH	4	562479	562477	C 497					
C 433	FR SERVICE CPT. KNEEL. PRESS. SW	PED WP	2	561566	561690	C 498					
C 434	FRONT JCT. BOX-DIODES	AMP MNL	15	561987	561986	C 499					
C 435	FR SERVICE CPT.(RH) KNEEL. PIEZO	AMP MNL	2	560900	560898	C 500	FR LH UPPER WHELL CPT -PRODRIVER	MOLEX	6	562070	562069
C 436	RH HAT RACK-WCL CENTER ROOF ACC	AMP CPC	16	561639	561640	C 501	FR LH UPPER WHELL CPT -PRODRIVER	PED MP	7	562433	-----
C 437	RH HAT RACK-WCL FR & RR SECT.	AMP CPC	24	561642	561643	C 502	LH DASH PANEL-PRE HEATER SW.	EATON	8	-----	562763
C 438						C 503	LH CONSOLE-PRE HEATER SW.	EATON	2	-----	561837
C 439						C 504	LH CONSOLE WEBASTO TIMER	AMP	8	-----	562852
C 440						C 505	LH CONSOLE ESPAR TIMER	AMP	9	-----	562681
C 441						C 506	FR JCT BOX CPT. DIGITAL CLOCK	AMP	4	561685	561687
C 442						C 507	FR SECT. LH HAT-RACK DIG. CLOCK	MOLEX	4	561477	561476
C 443						C 508	RR JCT BOX-FAN CLUTCH RETARDER	AMP MNL	6	561552	561515
C 444						C 509	FR LH UPPER WHELL CPT -DATA LOGGER	PED MP	16	-----	562530
C 445						C 510	FR LH UPPER WHELL CPT -DATA LOGGER	DEUTSCH	9	562531	-----
C 446						C 511	FR LH UPPER WHELL CPT -DATA LOGGER	PED MP	4	562532	-----
C 447						C 512	FR LH UPPER WHELL CPT -DATA LOGGER	PED MP	10	562533	-----
C 448						C 513	FR LH UPPER WHELL CPT -DATA LOGGER	AMP MNL	3	561667	561550
C 449						C 514	FR LH UPPER WHELL CPT -DATA LOGGER	PED MP	6	562433	562417
C 450	SOUND SYS. JCT. PANEL	MOLEX	4	562507	562503	C 515	FR JCT BOX CPT.-INTERCOM	MOLEX	4	561477	561476
C 451	WIRELESS MICRO-FIRST CPT BAG	MOLEX	2	562550	562549	C 516	FR JCT BOX CPT.-INTERCOM	MOLEX	6	562070	562069
C 452	UNDER DASH INSTR. PANEL	MOLEX	2	562550	562549	C 517	LAVATORY WALL-INTERCOM	MOLEX	6	562070	562069
C 453	SOUND SYS. JCT.PANEL-VCP	PED WP	2	561566	561680	C 519	UNDER DASH RH-SEDAN DOOR	HUMPHREY	2	-----	562580
C 454	SOUND SYS.JCT.PAN.-FILT. VCP	PED WP	2	561566	561680	C 520	UNDER DASH RH-SEDAN DOOR	HUMPHREY	2	-----	641385
C 455	WIRELESS MICRO-LH HAT-RACK	CINCH	2	562554	562551	C 521	UNDER DASH RH-SEDAN DOOR	HUMPHREY	2	-----	641385
C 456	WORLD TRANSM.-RETARDER ACCUM.	PED MP	2	-----	562427	C 522	FR JCT BOX-DAYTIME LTS MODULE	BOSCH	5	-----	561183
C 457	WORLD TRANSM.-MAIN CONNECTOR	DEUTSCH	31	562572	562536	C 523	FR JCT BOX-FUSE BLOCK	PED	8	562647	562646
C 458	WORLD TRANSM.-TURBINE SP.SENS	PED MP	2	-----	562426	C 524	FR JCT BOX-FUSE BLOCK	PED	8	562647	562646

# CONNECTORS CODE

NO	LOCATION	TYPE	CAVITY	#PIN	#SOCKET	NO	LOCATION	TYPE	CAVITY	#PIN	#SOCKET
				HOUSING	HOUSING					HOUSING	HOUSING
C 525	FR JCT BOX-FUSE BLOCK	PED	8	562647	562646	C 592	L.H.CONSOLE - MIRROR R.H.	EURAMTEC	8	-----	562799
C 526	FR JCT BOX-FUSE BLOCK	PED	8	562647	562646	C 593	BATTERY CMPT. - CHARGER	PED WP	3	561781	561782
C 527	FR JCT BOX-FUSE BLOCK	PED	8	562647	562646	C 594	FRONT ROOF - DRIVERS LIGHT	LEEKRAFT		-----	562803
C 528	FR JCT BOX-FUSE BLOCK	PED	8	562647	562646	C 595	DASH CENTER MODULE - OPEN DOOR	MOLEX	4	561477	561476
C 529	FR JCT BOX-12V OUTLET	AMP MNL	2	561247	561248	C 596	DASH CENTER MODULE - CLOSE DOOR	MOLEX	4	561477	561476
C 530	RR JCT BOX-FUSE BLOCK	PED	8	562647	562646	C 597	L.H. DASH PANEL - DISPLAY SET SW.	MOLEX	5		562812
C 531	RR JCT BOX-FUSE BLOCK	PED	8	562647	562646	C 598	L.H. DASH PANEL - DISPLAY SET SW.	MOLEX	5		562812
C 532	RR JCT BOX-FUSE BLOCK	PED	8	562647	562646	C 599					
C 533	RR JCT BOX-FUSE BLOCK	PED	8	562647	562646	C 600	ENGINE CPT.-A/C LOW PRESS SW. UNLOAD	PED	2	562348	562471
C 534	RR JCT BOX-FUSE BLOCK	PED	8	562647	562646	C 601	L.H. ROOF - WINDOW AJAR	AMP MNL	2	561248	561247
C 535	RR JCT BOX-FIRE MODULE DETECT.	AMP MNL	3	561667	561550	C 602	L.H. ROOF - WINDOW AJAR	MOLEX	4	561477	561476
C 536	UNDER DASH RH-DRIVER'S HTR TEMP. CTR	AMP MNL	6	561552	561515	C 603	R.H. ROOF - WINDOW AJAR	AMP MNL	2	561248	561247
C 537	BATT. CPT.-A/C PRESS. SIGN. RLY	AMP MNL	2	561248	561247	C 604					
C 538	FR SERVICE CPT.-OUTSIDE TEMP. SENSOR	AMP MNL	2	561248	561247	C 605	HAT RACK - MOTOR FAN	PED	2	560997	561030
C 539	HVAC DASH MODULE OUTPUT CON	MOLEX	24		562780	C 606	HAT RACK - MOTOR FAN	PED	2	560997	561030
C 540	HVAC DASH MODULE INPUT CON	MOLEX	22		562781	C 607	FRONT SERVICE CMPT. RPM SIGNAL	PED WP	2	561566	561690
C 541	SOUND SYS. JCT PANEL-AUDIO SEAT SYS.	PED WP	2	561566	561690	C 608	FRONT SERVICE CMPT. SPEED SIGNAL	PED WP	2	561566	561690
C 542	LH HAT RACK-AUDIO SEAT SYSTEM	AMP MNL	3	561667	561550	C 609	LAVATORY - NIGHT LIGHT				
C 543	RR JCT BOX-PARK. BRAKE STOP LTS RESIS.	PED WP	2	561566	561690	C 610	RR JCT BOX	AMP MNL	6	561552	561515
C 544	SOUND SYS JCT PANEL-AUDIO SEAT SYS.	PED WP	3	561781	562428	C 611	HAT RACK READING LTS RICON	MOLEX	6	562558	562557
C 545	LH HAT RACK-AUDIO SEAT SYSTEM	AMP MNL	3	561667	561550	C 612	HAT -RACK FLUOR. INSTATION LTS RICON	MOLEX	4	562507	562503
C 546						C 613	HAT -RACK INDIRECT LTS RICON	AMP MNL	3	561667	561550
C 547	RH DASH PANEL-ACCESSORIES	AMP CPC	37	561645	561646	C 614	HAT -RACK INDIRECT LTS RICON	AMP MNL	3	561667	561550
C 548	LH DASH PANEL-T.T. LT. TEST SW.	EATON	8	-----	562763	C 615					
C 549	LH DASH PANEL-FAN CLUTCH OVERR. SW	EATON	8	-----	562763	C 616					
C 550	LAST LUGG. CPT. -WCL RICON	AMP CPC	16	561694	561695	L X	CLUSTER	JAE	22		562766
C 551	LAST LUGG. CPT. -WCL RICON	AMP CPC	16	561694	561695	L Y	CLUSTER	JAE	30		562767
C 552	LAST LUGG. CPT. -WCL RICON	AMP CPC	9	561636	561637	R X	CLUSTER	JAE	22		562764
C 553	UNDER DASH R.H. - CONTROL. HEAD	MOLEX	16	-----	562559						
C 554	UNDER DASH R.H. - CONTROL. HEAD	MOLEX	16	-----	562559						
C 555	UNDER DASH R.H. - CONTROL. HEAD	MOLEX	16	-----	562559						
C 556	UNDER DASH R.H. - RADIO ACC.	MOLEX	2	562550	562549						
C 557	UNDER DASH R.H. - RADIO ACC.	MOLEX	9	562556	562555						
C 558	UNDER DASH R.H. - RADIO ACC.	MOLEX	4	562507	562503						
C 559	SOUND SYS. JCT. PANEL - FILTER AMPLI	PED WP	2	561566	561690						
C 560	SOUND SYS. JCT. PANEL - POWER AMPLI	MOLEX	4	562507	562503						
C 561	L.H. HAT RACK - WIRELESS MICRO	MOLEX	4	562507	562503						
C 562	L.H. HAT RACK - VCP	MOLEX	9	562556	562555						
C 563	L.H MODESTY PANEL - DRIVERS SPK.	MOLEX	4	562507	562503						
C 564	L.H MODESTY PANEL - MICRO	MOLEX	4	562507	562503						
C 565	R.H MODESTY PANEL - MICRO	MOLEX	4	562507	562503						
C 566	L.H. CONSOLE - BOOM MICRO	MOLEX	4	562507	562503						
C 567	L.H. CONSOLE - DRIVERS MICRO	MOLEX	4	562507	562503						
C 568	SOUND SYS. JCT. PANEL - PASS. SPK	CINCH	4	562553	562552						
C 569	SOUND SYS. JCT. PANEL - POWER AMPLI.	MOLEX	9	562556	562555						
C 570	UNDER DASH PANEL TTLT	MOLEX	6		562464						
C 571	UNDER DASH PANEL TTLT	MOLEX	20		562778						
C 572	UNDER DASH PANEL TTLT	MOLEX	18		562779						
C 573	UNDER DASH PANEL TTLT	MOLEX	8		562465						
C 574	HAT -RACK FLUOR. INDIRECT LIGHTING	MOLEX	6	-----	562759						
C 575	HAT -RACK FLUOR. INSTATION LIGHT	MOLEX	4	562507	562503						
C 576	HAT -RACK FLUOR. INDIRECT LIGHTING	AMP MNL	3	561667	561550						
C 577	HAT -RACK FLUOR. INDIRECT LIGHTING	AMP MNL	3	561667	561550						
C 578	HAT -RACK FLUOR. INSTATION LIGHT	MOLEX	4	562507	562503						
C 579											
C 580	RH DASH PANEL-HAT RACK FAN SW	EATON	8	-----	562763						
C 581											
C 582	FRONT SERVICE CMPT. - WINDOWS AJAR	PED WP	2	561566	561690						
C 583	L.H. DASH PANEL - MASTER KEY	DEUTSCH	2	562486	562485						
C 584	FRONT SERVICE CMPT. - AIR HORH	HUMPHREY	3	-----	641385						
C 585											
C 586											
C 587											
C 588	FRONT SERVICE CPT. CENTER SOUND SYS.	AMP. CPC	37	561645	561646						
C 589	UNDER DASH - L.H. MIRROR	AMP MNL	9	561670	561669						
C 590	UNDER DASH - R.H. MIRROR	AMP MNL	9	561670	561669						
C 591	L.H.CONSOLE - MIRROR L.H.	EURAMTEC	8	-----	562799						



# DIODES NUMBER CODE

No.	PAGE	AMP	#PREV.	LOCATION	FUNCTION	No.	PAGE	AMP	#PREV.	LOCATION	FUNCTION
D 1						D 58	17	3A	561740	FR JCT BOX	RR HIGH BUOY - KNEELING
D 2						D 59	13.2	3A	561740	RJB A/C JCT PANEL	A/C & HEAT BYPASS SWITCH
D 3						D 60	13.2	3A	561740	RJB A/C JCT PANEL	A/C COMPR.CLUTCH SUPPRESSOR
D 4	9.2	3A	561740	FR JCT BOX	WARNING HAZARD-RH	D 61	9.2	3A	561740	FR JCT BOX	KNEELING SIDE FR RH DIRECTIONAL LT
D 5	9.2	3A	561740	FR JCT BOX	WARNING HAZARD-LH	D 62	13.2	3A	561740	RJB A/C JCT PANEL	WATER PUMP FEED
D 6	5	3A	561740	FR JCT BOX	WCL NEUT. SIGN INTERFACE TO PARK BRK TTLT	D 63	17	3A	561740	FR JCT BOX	LAVATORY SONALERT
D 7						D 64	17	3A	561740	FR JCT BOX	WCL DOOR ALARM
D 8						D 65	13.2	3A	561740	RJB A/C JCT PANEL	WATER PUMP - PRE-HEAT FEED
D 9	12	3A	561740	FR L.H. HAT-RACK	HOSTESS & PASSENGER CHIME	D 66	13.2	3A	561740	RJB A/C JCT PANEL	WATER VALVE - HEAT SW. FEED
D 10						D 67	9.2	3A	561740	UNDER DASH	AUDIBLE FLASHER RLY - RH
D 11	17	3A	561740	RR JCT BOX	LAVATORY OCCUPIED SIGN	D 68	9.2	3A	561740	UNDER DASH	AUDIBLE FLASHER RLY - LH
D 12	17	3A	561740	RR JCT BOX	LAVATORY OCCUPIED SIGN	D 69					
D 13	17	3A	561740	FR DEST. SIGN	FR DESTINATION SIGN	D 70	18	3A	561740	FR JCT BOX	FR HIGH BUOY - KNEELING
D 14	17	3A	561740	FR DEST. SIGN	FR DESTINATION SIGN	D 71	18	3A	561740	FR JCT BOX	FR HIGH BUOY - KNEELING
D 15	18	3A	561740	FR JCT BOX	KNEELING SYSTEM CTR-UP	D 72	18	3A	561740	FR JCT BOX	FR HIGH BUOY - KNEELING
D 16	18	3A	561740	FR JCT BOX	KNEELING SYSTEM CTR-DOWN	D 73	18	3A	561740	FR JCT BOX	FR HIGH BUOY - KNEELING
D 17	9.2	3A	561740	FR JCT BOX	WARNING HAZARD-LH	D 74					
D 18	9.2	3A	561740	FR JCT BOX	WARNING HAZARD-RH	D 75	4	3A	381351	BAT CPT	STARTER-SUPPRESSOR COIL RLY
D 19	9	3A	561740	FR JCT BOX	DAYTIME RUN LTS-PARK BRK CALL SW.	D 76					
D 20	9	3A	561740	FR JCT BOX	DAYTIME RUN LTS-HEAD LT SW	D 77	18	3A	561740	FR JCT BOX	PARKING BRAKE - KNEELING
D 21	18	3A	561740	FR JCT BOX	KNEELING SYSTEM FEED BACK	D 78	26	3A	561740	LH CONSOLE	PRE-HEAT WATER HEATER SW.
D 22						D 79	26	3A	561740	LH CONSOLE	PRE-HEAT WATER HEATER SW.
D 23						D 80					
D 24						D 81	18	3A	561740	FR JCT BOX	PIEZO-KNEELING
D 25	11.1	3A	561740	FR JCT BOX	LUGGAGE DOOR AJAR T.T.LT.	D 82	18	3A	561740	FR JCT BOX	PIEZO-KNEELING
D 26	11.1	3A	561740	FR JCT BOX	LUGGAGE DOOR AJAR T.T.LT.	D 83	8	3A	561740	RR JCT BOX	FAN CLUTCH W/RETARDER
D 27	11.1	3A	561740	FR JCT BOX	LUGGAGE DOOR AJAR T.T.LT.	D 84	13.2	3A	561740	RJB A/C JCT PANEL	WATER VALVE
D 28	11.1	3A	561740	FR JCT BOX	LUGGAGE DOOR AJAR T.T.LT.	D 85	13.2	3A	561740	RJB A/C JCT PANEL	WATER PUMP
D 29	11.1	3A	561740	FR JCT BOX	LUGGAGE DOOR AJAR T.T.LT.	D 86	16	3A	561740	UNDER DASH RH	ENTRANCE DOOR SEDAN
D 30	11.1	3A	561740	FR JCT BOX	LUGGAGE DOOR AJAR T.T.LT.	D 87	16	3A	561740	UNDER DASH RH	ENTRANCE DOOR SEDAN
D 31						D 88	16	3A	561740	UNDER DASH RH	ENTRANCE DOOR SEDAN
D 32						D 89	16	3A	561740	UNDER DASH RH	ENTRANCE DOOR SEDAN
D 33						D 90	16	3A	561740	UNDER DASH RH	ENTRANCE DOOR SEDAN
D 34						D 91	16	3A	561740	UNDER DASH RH	ENTRANCE DOOR SEDAN
D 35	25	3A	561740	RR JCT BOX	WCL DOOR AJAR ALARM T.T.LT.						
D 36	11.4	3A	561740	RR JCT BOX	CHARGEUR 24V/110V						
D 37	11.4	3A	561740	RR JCT BOX	CHARGEUR 24V/110V						
D 38	11.4	3A	561740	RR JCT BOX	CHARGEUR 24V/110V						
D 39											
D 40											
D 41											
D 42											
D 43	10	3A	561740	LOWER WIPER MOT.	WIPER MOTOR SUPPRESSOR						
D 44	10	3A	561740	LOWER WIPER MOT.	WIPER MOTOR SUPPRESSOR						
D 45	10	3A	561740	UPPER WIPER MOT.	WIPER MOTOR SUPPRESSOR						
D 46											
D 47											
D 48											
D 49											
D 50											
D 51											
D 52											
D 53											
D 54											
D 55											
D 56											
D 57											



# DIODES NUMBER CODE

No.	PAGE	AMP	#PREV.	LOCATION	FUNCTION	No.	PAGE	AMP	#PREV.	LOCATION	FUNCTION
D 1						D 59	13.2	3A	561740	RJB A/C JCT PANEL	A/C & HEAT BYPASS SWITCH
D 2						D 60	13.2	3A	561740	RJB A/C JCT PANEL	A/C COMPR.CLUTCH SUPPRESSOR
D 3						D 61	9.2	3A	561740	FR JCT BOX	KNEELING SIDE FR RH DIRECTIONNAL LT
D 4	9.2	3A	561740	FR JCT BOX	WARNING HAZARD-RH	D 62	13.2	3A	561740	RJB A/C JCT PANEL	WATER PUMP FEED
D 5	9.2	3A	561740	FR JCT BOX	WARNING HAZARD-LH	D 63	17	3A	561740	FR JCT BOX	LAVATORY SONALERT
D 6	5	3A	561740	FR JCT BOX	WCL NEUT. SIGN INTERFACE TO PARK BRK TTLT	D 64	17	3A	561740	FR JCT BOX	WCL DOOR ALARM
D 7						D 65	13.2	3A	561740	RJB A/C JCT PANEL	WATER PUMP - PRE-HEAT FEED
D 8						D 66	13.2	3A	561740	RJB A/C JCT PANEL	WATER VALVE - HEAT SW. FEED
D 9						D 67	9.2	3A	561740	UNDER DASH	AUDIBLE FLASHER RLY - RH
D 10						D 68	9.2	3A	561740	UNDER DASH	AUDIBLE FLASHER RLY - LH
D 11	17	3A	561740	RR JCT BOX	LAVATORY OCCUPIED SIGN	D 69					
D 12	17	3A	561740	RR JCT BOX	LAVATORY OCCUPIED SIGN	D 70	18	3A	561740	FR JCT BOX	FR HIGH BUOY - KNEELING
D 13	17	3A	561740	FR DEST. SIGN	FR DESTINATION SIGN	D 71	18	3A	561740	FR JCT BOX	FR HIGH BUOY - KNEELING
D 14	17	3A	561740	FR DEST. SIGN	FR DESTINATION SIGN	D 72	18	3A	561740	FR JCT BOX	FR HIGH BUOY - KNEELING
D 15	18	3A	561740	FR JCT BOX	KNEELING SYSTEM CTR-UP	D 73	18	3A	561740	FR JCT BOX	FR HIGH BUOY - KNEELING
D 16	18	3A	561740	FR JCT BOX	KNEELING SYSTEM CTR-DOWN	D 74					
D 17	9.2	3A	561740	FR JCT BOX	WARNING HAZARD-LH	D 75	4	3A	381351	BAT CPT	STARTER-SUPPRESSOR COIL RLY
D 18	9.2	3A	561740	FR JCT BOX	WARNING HAZARD-RH	D 76					
D 19	9	3A	561740	FR JCT BOX	DAYTIME RUN LTS-PARK BRK CALL SW.	D 77	18	3A	561740	FR JCT BOX	PARKING BRAKE - KNEELING
D 20	9	3A	561740	FR JCT BOX	DAYTIME RUN LTS-HEAD LT SW	D 78	26	3A	561740	LH CONSOLE	PRE-HEAT WATER HEATER SW.
D 21	18	3A	561740	FR JCT BOX	KNEELING SYSTEM FEED BACK	D 79	26	3A	561740	LH CONSOLE	PRE-HEAT WATER HEATER SW.
D 22						D 80					
D 23						D 81	18	3A	561740	FR JCT BOX	PIEZO-KNEELING
D 24						D 82	18	3A	561740	FR JCT BOX	PIEZO-KNEELING
D 25	11.1	3A	561740	FR JCT BOX	LUGGAGE DOOR AJAR T.T.LT.	D 83	8	3A	561740	RR JCT BOX	FAN CLUTCH W/RETARDER
D 26	11.1	3A	561740	FR JCT BOX	LUGGAGE DOOR AJAR T.T.LT.	D 84	13.2	3A	561740	RJB A/C JCT PANEL	WATER VALVE
D 27	11.1	3A	561740	FR JCT BOX	LUGGAGE DOOR AJAR T.T.LT.	D 85	13.2	3A	561740	RJB A/C JCT PANEL	WATER PUMP
D 28	11.1	3A	561740	FR JCT BOX	LUGGAGE DOOR AJAR T.T.LT.	D 86	16	3A	561740	UNDER DASH RH	ENTRANCE DOOR SEDAN
D 29	11.1	3A	561740	FR JCT BOX	LUGGAGE DOOR AJAR T.T.LT.	D 87	16	3A	561740	UNDER DASH RH	ENTRANCE DOOR SEDAN
D 30	11.1	3A	561740	FR JCT BOX	LUGGAGE DOOR AJAR T.T.LT.	D 88	16	3A	561740	UNDER DASH RH	ENTRANCE DOOR SEDAN
D 31						D 89	16	3A	561740	UNDER DASH RH	ENTRANCE DOOR SEDAN
D 32						D 90	16	3A	561740	UNDER DASH RH	ENTRANCE DOOR SEDAN
D 33						D 91	16	3A	561740	UNDER DASH RH	ENTRANCE DOOR SEDAN
D 34											
D 35	25	3A	561740	RR JCT BOX	WCL DOOR AJAR ALARM T.T.LT.						
D 36	11.4	3A	561740	RR JCT BOX	CHARGEUR 24V/110V						
D 37	11.4	3A	561740	RR JCT BOX	CHARGEUR 24V/110V						
D 38	11.4	3A	561740	RR JCT BOX	CHARGEUR 24V/110V						
D 39											
D 40											
D 41											
D 42											
D 43	10	3A	561740	LOWER WIPER MOT.	WIPER MOTOR SUPPRESSOR						
D 44	10	3A	561740	LOWER WIPER MOT.	WIPER MOTOR SUPPRESSOR						
D 45	10	3A	561740	UPPER WIPER MOT.	WIPER MOTOR SUPPRESSOR						
D 46											
D 47											
D 48											
D 49											
D 50											
D 51											
D 52											
D 53											
D 54											
D 55											
D 56											
D 57											
D 58	17	3A	561740	FR JCT BOX	RR HIGH BUOY - KNEELING						

# DIODES NUMBER CODE

No.	PAGE	AMP	#PREV.	LOCATION	FUNCTION	No.	PAGE	AMP	#PREV.	LOCATION	FUNCTION
D 1	13.1	3A	561740	RJB A/C JCT PANEL	LIQ. SOL. VALVE SUPPRESSOR	D 58	17	3A	561740	FR JCT BOX	RR HIGH BUOY - KNEELING
D 2	4.1	3A	561740	BATT. CPT.	EATON TRANSMISSION	D 59	13.2	3A	561740	RJB A/C JCT PANEL	A/C & HEAT BYPASS SWITCH
D 3	1.1	3A	561740	BATT. CPT.	24V DISC. CUT OUT RLY	D 60	13.2	3A	561740	RJB A/C JCT PANEL	A/C COMPR.CLUTCH SUPPRESSOR
D 4	9.2	3A	561740	FR JCT BOX	WARNING HAZARD-RH	D 61	9.2	3A	561740	FR JCT BOX	KNEELING SIDE FR RH DIRECTIONAL LT
D 5	9.2	3A	561740	FR JCT BOX	WARNING HAZARD-LH	D 62	13.2	3A	561740	RJB A/C JCT PANEL	WATER PUMP FEED
D 6	5	3A	561740	FR JCT BOX	WCL NEUT. SIGN INTERFACE TO PARK BRK TTLT	D 63	17	3A	561740	FR JCT BOX	LAVATORY SONALERT
D 7						D 64	17	3A	561740	FR JCT BOX	WCL DOOR ALARM
D 8						D 65	13.2	3A	561740	RJB A/C JCT PANEL	WATER PUMP - PRE-HEAT FEED
D 9	12	3A	561740	FR L.H. HAT-RACK	HOSTESS & PASSENGER CHIME	D 66	13.2	3A	561740	RJB A/C JCT PANEL	WATER VALVE - HEAT SW. FEED
D 10						D 67	9.2	3A	561740	UNDER DASH	AUDIBLE FLASHER RLY - RH
D 11	17	3A	561740	RR JCT BOX	LAVATORY OCCUPIED SIGN	D 68	9.2	3A	561740	UNDER DASH	AUDIBLE FLASHER RLY - LH
D 12	17	3A	561740	RR JCT BOX	LAVATORY OCCUPIED SIGN	D 69					
D 13	17	3A	561740	FR DEST. SIGN	FR DESTINATION SIGN	D 70	18	3A	561740	FR JCT BOX	FR HIGH BUOY - KNEELING
D 14	17	3A	561740	FR DEST. SIGN	FR DESTINATION SIGN	D 71	18	3A	561740	FR JCT BOX	FR HIGH BUOY - KNEELING
D 15	18	3A	561740	FR JCT BOX	KNEELING SYSTEM CTR-UP	D 72	18	3A	561740	FR JCT BOX	FR HIGH BUOY - KNEELING
D 16	18	3A	561740	FR JCT BOX	KNEELING SYSTEM CTR-DOWN	D 73	18	3A	561740	FR JCT BOX	FR HIGH BUOY - KNEELING
D 17	9.2	3A	561740	FR JCT BOX	WARNING HAZARD-LH	D 74					
D 18	9.2	3A	561740	FR JCT BOX	WARNING HAZARD-RH	D 75	4	3A	381351	BAT CPT	STARTER-SUPPRESSOR COIL RLY
D 19	9	3A	561740	FR JCT BOX	DAYTIME RUN LTS-PARK BRK CALL SW.	D 76					
D 20	9	3A	561740	FR JCT BOX	DAYTIME RUN LTS-HEAD LT SW	D 77	18	3A	561740	FR JCT BOX	PARKING BRAKE - KNEELING
D 21	18	3A	561740	FR JCT BOX	KNEELING SYSTEM FEED BACK	D 78	26	3A	561740	LH CONSOLE	PRE-HEAT WATER HEATER SW.
D 22						D 79	26	3A	561740	LH CONSOLE	PRE-HEAT WATER HEATER SW.
D 23						D 80					
D 24						D 81	18	3A	561740	FR JCT BOX	PIEZO-KNEELING
D 25	11.1	3A	561740	FR JCT BOX	LUGGAGE DOOR AJAR T.T.LT.	D 82	18	3A	561740	FR JCT BOX	PIEZO-KNEELING
D 26	11.1	3A	561740	FR JCT BOX	LUGGAGE DOOR AJAR T.T.LT.	D 83	8	3A	561740	RR JCT BOX	FAN CLUTCH W/RETARDER
D 27	11.1	3A	561740	FR JCT BOX	LUGGAGE DOOR AJAR T.T.LT.	D 84	13.2	3A	561740	RJB A/C JCT PANEL	WATER VALVE
D 28	11.1	3A	561740	FR JCT BOX	LUGGAGE DOOR AJAR T.T.LT.	D 85	13.2	3A	561740	RJB A/C JCT PANEL	WATER PUMP
D 29	11.1	3A	561740	FR JCT BOX	LUGGAGE DOOR AJAR T.T.LT.	D 86	16	3A	561740	UNDER DASH RH	ENTRANCE DOOR SEDAN
D 30	11.1	3A	561740	FR JCT BOX	LUGGAGE DOOR AJAR T.T.LT.	D 87	16	3A	561740	UNDER DASH RH	ENTRANCE DOOR SEDAN
D 31						D 88	16	3A	561740	UNDER DASH RH	ENTRANCE DOOR SEDAN
D 32						D 89	16	3A	561740	UNDER DASH RH	ENTRANCE DOOR SEDAN
D 33						D 90	16	3A	561740	UNDER DASH RH	ENTRANCE DOOR SEDAN
D 34						D 91	16	3A	561740	UNDER DASH RH	ENTRANCE DOOR SEDAN
D 35	25	3A	561740	RR JCT BOX	WCL DOOR AJAR ALARM T.T.LT.						
D 36	11.4	3A	561740	RR JCT BOX	CHARGEUR 24V/110V						
D 37	11.4	3A	561740	RR JCT BOX	CHARGEUR 24V/110V						
D 38	11.4	3A	561740	RR JCT BOX	CHARGEUR 24V/110V						
D 39											
D 40											
D 41											
D 42											
D 43	10	3A	561740	LOWER WIPER MOT.	WIPER MOTOR SUPPRESSOR						
D 44	10	3A	561740	LOWER WIPER MOT.	WIPER MOTOR SUPPRESSOR						
D 45	10	3A	561740	UPPER WIPER MOT.	WIPER MOTOR SUPPRESSOR						
D 46											
D 47											
D 48											
D 49											
D 50											
D 51											
D 52											
D 53											
D 54											
D 55											
D 56											
D 57											

# DIODES NUMBER CODE

No.	PAGE	AMP	#PREV.	LOCATION	FUNCTION	No.	PAGE	AMP	#PREV.	LOCATION	FUNCTION
D 1	13.1	3A	561740	RJB A/C JCT PANEL	LIQ. SOL. VALVE SUPPRESSOR	D 58	17	3A	561740	FR JCT BOX	RR HIGH BUOY - KNEELING
D 2	4.1	3A	561740	BATT. CPT.	EATON TRANSMISSION	D 59	13.2	3A	561740	RJB A/C JCT PANEL	A/C & HEAT BYPASS SWITCH
D 3	1.1	3A	561740	BATT. CPT.	24V DISC. CUT OUT RLY	D 60	13.2	3A	561740	RJB A/C JCT PANEL	A/C COMPR.CLUTCH SUPPRESSOR
D 4	9.2	3A	561740	FR JCT BOX	WARNING HAZARD-RH	D 61	9.2	3A	561740	FR JCT BOX	KNEELING SIDE FR RH DIRECTIONAL LT
D 5	9.2	3A	561740	FR JCT BOX	WARNING HAZARD-LH	D 62	13.2	3A	561740	RJB A/C JCT PANEL	WATER PUMP FEED
D 6	5	3A	561740	FR JCT BOX	WCL NEUT. SIGN INTERFACE TO PARK BRK TTLT	D 63	17	3A	561740	FR JCT BOX	LAVATORY SONALERT
D 7						D 64	17	3A	561740	FR JCT BOX	WCL DOOR ALARM
D 8						D 65	13.2	3A	561740	RJB A/C JCT PANEL	WATER PUMP - PRE-HEAT FEED
D 9	12	3A	561740	FR L.H. HAT-RACK	HOSTESS & PASSENGER CHIME	D 66	13.2	3A	561740	RJB A/C JCT PANEL	WATER VALVE - HEAT SW. FEED
D 10	9.1	3A	561740	FR JCT BOX	DAY-TIME RUN LIGHT -ENGINE NOT RUN	D 67	9.2	3A	561740	UNDER DASH	AUDIBLE FLASHER RLY - RH
D 11	17	3A	561740	RR JCT BOX	LAVATORY OCCUPIED SIGN	D 68	9.2	3A	561740	UNDER DASH	AUDIBLE FLASHER RLY - LH
D 12	17	3A	561740	RR JCT BOX	LAVATORY OCCUPIED SIGN	D 69					
D 13	17	3A	561740	FR DEST. SIGN	FR DESTINATION SIGN	D 70	18	3A	561740	FR JCT BOX	FR HIGH BUOY - KNEELING
D 14	17	3A	561740	FR DEST. SIGN	FR DESTINATION SIGN	D 71	18	3A	561740	FR JCT BOX	FR HIGH BUOY - KNEELING
D 15	18	3A	561740	FR JCT BOX	KNEELING SYSTEM CTR-UP	D 72	18	3A	561740	FR JCT BOX	FR HIGH BUOY - KNEELING
D 16	18	3A	561740	FR JCT BOX	KNEELING SYSTEM CTR-DOWN	D 73	18	3A	561740	FR JCT BOX	FR HIGH BUOY - KNEELING
D 17	9.2	3A	561740	FR JCT BOX	WARNING HAZARD-LH	D 74					
D 18	9.2	3A	561740	FR JCT BOX	WARNING HAZARD-RH	D 75	4	3A	381351	BAT CPT	STARTER-SUPPRESSOR COIL RLY
D 19	9	3A	561740	FR JCT BOX	DAYTIME RUN LTS-PARK BRK CALL SW.	D 76					
D 20	9	3A	561740	FR JCT BOX	DAYTIME RUN LTS-HEAD LT SW	D 77	18	3A	561740	FR JCT BOX	PARKING BRAKE - KNEELING
D 21	18	3A	561740	FR JCT BOX	KNEELING SYSTEM FEED BACK	D 78	26	3A	561740	LH CONSOLE	PRE-HEAT WATER HEATER SW.
D 22						D 79	26	3A	561740	LH CONSOLE	PRE-HEAT WATER HEATER SW.
D 23						D 80					
D 24						D 81	18	3A	561740	FR JCT BOX	PIEZO-KNEELING
D 25	11.1	3A	561740	FR JCT BOX	LUGGAGE DOOR AJAR T.T.LT.	D 82	18	3A	561740	FR JCT BOX	PIEZO-KNEELING
D 26	11.1	3A	561740	FR JCT BOX	LUGGAGE DOOR AJAR T.T.LT.	D 83	8	3A	561740	RR JCT BOX	FAN CLUTCH W/RETARDER
D 27	11.1	3A	561740	FR JCT BOX	LUGGAGE DOOR AJAR T.T.LT.	D 84	13.2	3A	561740	RJB A/C JCT PANEL	WATER VALVE
D 28	11.1	3A	561740	FR JCT BOX	LUGGAGE DOOR AJAR T.T.LT.	D 85	13.2	3A	561740	RJB A/C JCT PANEL	WATER PUMP
D 29	11.1	3A	561740	FR JCT BOX	LUGGAGE DOOR AJAR T.T.LT.	D 86	16	3A	561740	UNDER DASH RH	ENTRANCE DOOR SEDAN
D 30	11.1	3A	561740	FR JCT BOX	LUGGAGE DOOR AJAR T.T.LT.	D 87	16	3A	561740	UNDER DASH RH	ENTRANCE DOOR SEDAN
D 31						D 88	16	3A	561740	UNDER DASH RH	ENTRANCE DOOR SEDAN
D 32						D 89	16	3A	561740	UNDER DASH RH	ENTRANCE DOOR SEDAN
D 33						D 90	16	3A	561740	UNDER DASH RH	ENTRANCE DOOR SEDAN
D 34						D 91	16	3A	561740	UNDER DASH RH	ENTRANCE DOOR SEDAN
D 35	25	3A	561740	RR JCT BOX	WCL DOOR AJAR ALARM T.T.LT.	D F1	8.1	3A	561740	RR. JCT. BOX	FAN CLUTCH - SUPPRESSOR
D 36	11.4	3A	561740	RR JCT BOX	CHARGEUR 24V/110V	D F2	8.1	3A	561740	RR. JCT. BOX	FAN CLUTCH - SUPPRESSOR
D 37	11.4	3A	561740	RR JCT BOX	CHARGEUR 24V/110V						
D 38	11.4	3A	561740	RR JCT BOX	CHARGEUR 24V/110V						
D 39											
D 40											
D 41											
D 42											
D 43	10	3A	561740	LOWER WIPER MOT.	WIPER MOTOR SUPPRESSOR						
D 44	10	3A	561740	LOWER WIPER MOT.	WIPER MOTOR SUPPRESSOR						
D 45	10	3A	561740	UPPER WIPER MOT.	WIPER MOTOR SUPPRESSOR						
D 46											
D 47											
D 48											
D 49											
D 50											
D 51											
D 52											
D 53											
D 54											
D 55											
D 56											
D 57											

# RELAYS NUMBER CODE

No.	PAGE	COIL V	#PREV.	LOCATION	FUNCTION	No.	PAGE	COIL V	#PREV.	LOCATION	FUNCTION
RF1	8	24V	561707	RR JCT BOX	FAN CLUTCH W/RET. SPEED 1	R 58					
RF2	8	24V	561707	RR JCT BOX	FAN CLUTCH W/RET. SPEED 2	R 59	9.3	12V	562092	RR JCT BOX	DOCKING LTS
RF3	8	24V	560772	RR JCT BOX	TIME DELAY	R 60					
RLA	16	24V	561707	UNDER DASH RH.	ENTRANCE DOOR SEDAN (LATCH)	R 61	9.3	24V	561707	RR JCT BOX	STOP LTS-JACOB & RET. SIGNAL
RLO	16	24V	561707	UNDER DASH RH.	ENTRANCE DOOR SEDAN (PRESS. SW.)	R 62					
RLT	16	24V	561707	UNDER DASH RH.	ENTRANCE DOOR SEDAN (LIGHT)	R 63					
RLV	16	24V	561707	UNDER DASH RH.	ENTRANCE DOOR SEDAN (VALVE)	R 64					
R 1	1.1	24V	561991	FR JCT BOX	ENGINE RUN (24) FR	R 65					
R 2	2	24V	561991	BATT. CPT.	ENGINE RUN (12) FR & RR	R 66	20.3	24V	561707	SS JCT PANEL	SOUND SYSTEM VIDEO
R 3	4	24V	561707	BATT. CPT.	FIELD RELAY	R 67	20.1	24V	561707	SS JCT PANEL	SOUND SYSTEM RADIO
R 4	4	24V	561005	BATT. CPT.	STARTING MOTOR	R 68	20.1	24V	561991	SS JCT PANEL	SOUND SYSTEM AMPLIFIER
R 5	5	24V	561707	FR JCT BOX	CRUISE CTR. STOP SIGN.	R 69					
R 6	9.3	24V	561707	RR JCT BOX	STOP LTS-PARKING BRAKE	R 70					
R 7	5	24V	561707	FR JCT BOX	FAST IDLE	R 71					
R 8	6	24V	561707	RR JCT BOX	12V IGNITION WT	R 72					
R 9	9.3	24V	561707	RR JCT BOX	BACK-UP LTS	R 73					
R 10						R 74					
R 11	5	24V	561707	RR JCT BOX	12V IGNITION DDEC3	R 75					
R 12	7	12V	562092	FR JCT BOX	ELECTRICAL HORNS	R 76					
R 13	9.3	24V	561707	FR JCT BOX	FOG LTS	R 77					
R 14	9.1	24V	561707	FR JCT BOX	BLINKER	R 78	1.1	12V	562092	FR JCT BOX	MASTER SWITCH
R 15	9.1	24V	561707	FR JCT BOX	FR MARKER LTS	R 79	23	24V	561707	GALLEY CPT.	GALLEY-REFRIGERATOR
R 16	9.1	24V	561707	FR JCT BOX	IDENT. & CLEARANCE LTS	R 80	11.1	24V	561707	RR JCT BOX	ENGINE COMPARTMENT LTS
R 17	9.1	24V	561707	RR JCT BOX	TAIL,LICENCE,MARKER-RR LTS	R 81					
R 18	9.1	24V	561707	FR JCT BOX	D R L-PARK BRK CUT-IN	R 82	19	24V	561707	FR JCT BOX	RETARDER WT
R 19	9.1	24V	561707	FR JCT BOX	HEADLAMPS (HI)	R 83					
R 20	9.1	24V	561707	FR JCT BOX	HEADLAMPS (LO)	R 84	8	24V	561707	RR JCT BOX	FAN CLUTCH-FIRST SPEED
R 21	9.2	24V	561707	FR JCT BOX	L.H. DIRECTIONNAL LT	R 85	8	24V	561707	RR JCT BOX	FAN CLUTCH-SECOND SPEED
R 22						R 86					
R 23	9.2	24V	561707	FR JCT BOX	R.H. DIRECTIONNAL LT	R 87	19	24V	561707	RR JCT BOX	ENGINE BRAKE REQUEST WT
R 24	9.2	24V	561707	FR JCT BOX	R.H. CORNERING LT	R 88					
R 25	9.2	24V	561707	FR JCT BOX	L.H. CORNERING LT	R 89	22	24V	561707	FR JCT BOX	HEATING WINDSHIELD
R 26	9.3	24V	561707	RR JCT BOX	STOP LTS	R 90	22	24V	561707	FR JCT BOX	HEATING WINDSHIELD
R 27	11.2	24V	561707	RR JCT BOX	AISLE & EMERG.EXIT - LTS	R 91	22	24V	561707	FR JCT BOX	HEATING WINDSHIELD
R 28	11.2	24V	561707	FR JCT BOX	DASH LTS RHEOSTAT	R 92	22	24V	561707	FR JCT BOX	HEATING WINDSHIELD
R 29	11.3	24V	561707	RR JCT BOX	READING LTS R.H.	R 93	26	24V	561707	RR JCT BOX	PRE-HEAT WATER HEATER (WEBASTO)
R 30	11.3	24V	561707	RR JCT BOX	READING LTS L.H.	R 94	25	24V	561707	RR JCT BOX	WCL - SYSTEM
R 31	11.3	24V	561707	RR JCT BOX	GENERAL LTS	R 95	25	24V	561707	RR JCT BOX	WCL - MAGNETIC SW. SIGN.
R 32	11.4	24V	561707	RR JCT BOX	24V FLUORESCENT	R 96	25	24V	561707	RR JCT BOX	WCL - DOOR AJAR ALARM
R 33	13.1	12V	562092	FR JCT BOX	BLOWER CUT-IN RLY	R 97	25	24V	561707	RR JCT BOX	WCL - DOOR AJAR PARK. BRAKE
R 34	13.1	24V	561707	RJB A/C JCT PANEL	A/C LOGIC PANEL	R 98	25	12V	561538	RR JCT BOX	WCL -
R 35	13.1	24V	561707	RJB A/C JCT PANEL	WATER PUMP	R 99	8	24V	561707	RR JCT BOX	RADIATOR FAN CLUTCH
R 36	13.1	24V	561707	RJB A/C JCT PANEL	A/C COMPRESSOR CLUTCH	R 100	4	12V	561538	RR JCT BOX	GENERATOR SIGNAL
R 37	10	24V	561707	FR JCT BOX	KNEELING LT	R 101					
R 38						R 102	17	24V	561707	RR JCT BOX	FUEL FILTER HEATER
R 39	13.2	24V	561005	BATT. CPT.	CONDENSER FAN MOTOR	R 103					
R 40	13.2	24V	561014	BATT. CPT.	CONDENSER SPEED CTR HI	R 104	13.3	24V	561707	RR JCT BOX	HAT-RACK FAN - L.H.
R 41	13.2	24V	561005	BATT. CPT.	CONDENSER SPEED CTR HI	R 105	13.3	24V	561707	RR JCT BOX	HAT-RACK FAN - R.H.
R 42						R 106	17.1	24V	561707	RR JCT BOX	LAVATORY FAN
R 43	18	24V	561707	FR JCT BOX	KNEELING SYSTEM	R 107					
R 44	18	24V	561707	FR JCT BOX	KNEELING SYSTEM	R 2010	26.2	24V	561230	WEBASTO PRE-HEAT	WEBASTO
R 45						V IMN	6	12V	562092	RR JCT BOX	VIM WORLD TR.-NEUTRAL SIGNAL
R 46						V IMR	6	12V	562092	RR JCT BOX	VIM WORLD TR.-B/U SIGNAL
R 47	23	24V	561707	GALLEY COMPT	GALLEY-LIQUID CONTAINERS	V IM1	6	12V	562092	RR JCT BOX	VIM WORLD TR.-OUTPUT 1
R 48	23	24V	561707	GALLEY COMPT	COFFEE MAKER	V IM2	6	12V	562092	RR JCT BOX	VIM WORLD TR.-OUTPUT 2 ENG. BRK DISABLE
R 49	21	24V	561707	FR JCT BOX	ABS - SERVICE BRK RLY	V IM3	6	12V	562092	RR JCT BOX	VIM WORLD TR.-OUTPUT 3 SPD SW. 5MPH NO NC
R 50	10	24V	561707	FR JCT BOX	UPPER WINDSHIELD WIPER	V IM4	6	12V	562092	RR JCT BOX	VIM WORLD TR.-OUTPUT 4 RETARD. ON SIGNAL
R 51	11.3	12V	562092	FR JCT BOX	DRIVER'S LTS RLY- ENT. DOOR SIGN.						
R 52	21	24V	561707	FR JCT BOX	ABS - W/TR SIGN. RETARDER						
R 53	1.1	24V	561991	RR JCT BOX	ENGINE RUN (24) RR						
R 54	1.1	24V	561991	BATT. CPT.	12V CUT OUT RLY RR						
R 55	1.1	24V	561991	BATT. CPT.	12V CUT OUT RLY FR						
R 56											
R 57	9.1	24V	561707	FR JCT BOX	DAY'S BLINKER						

# RELAYS NUMBER CODE

No. PAGE COIL V #PREV. LOCATION FUNCTION

No. PAGE COIL V #PREV. LOCATION FUNCTION

# RELAYS NUMBER CODE

No.	PAGE	COIL V	#PREV.	LOCATION	FUNCTION	No.	PAGE	COIL V	#PREV.	LOCATION	FUNCTION
RF1	8.1	24V	561707	RR JCT BOX	FAN CLUTCH W/RET. SPEED 1	R 58					
RF2	8.1	24V	561707	RR JCT BOX	FAN CLUTCH W/RET. SPEED 2	R 59	9.3	12V	562092	RR JCT BOX	DOCKING LTS
RF3	8.1	24V	560772	RR JCT BOX	TIME DELAY	R 60					
RLA	16.1	24V	561707	UNDER DASH RH.	ENTRANCE DOOR SEDAN (LATCH)	R 61	9.3	24V	561707	RR JCT BOX	STOP LTS-JACOB & RET. SIGNAL
RLO	16.1	24V	561707	UNDER DASH RH.	ENTRANCE DOOR SEDAN (PRESS. SW.)	R 62					
RLT	16.1	24V	561707	UNDER DASH RH.	ENTRANCE DOOR SEDAN (LIGHT)	R 63					
RLV	16.1	24V	561707	UNDER DASH RH.	ENTRANCE DOOR SEDAN (VALVE)	R 64					
R1	1.1	24V	561991	FR JCT BOX	ENGINE RUN (24) FR	R 65					
R2	2.1	24V	561991	BATT. CPT.	ENGINE RUN (12) FR & RR	R 66	20.3	24V	561707	SS JCT PANEL	SOUND SYSTEM VIDEO
R3						R 67	20.1	12V	562092	SS JCT PANEL	SOUND SYSTEM RADIO
R4	4.1	24V	561005	BATT. CPT.	STARTING MOTOR	R 68	20.1	24V	561991	SS JCT PANEL	SOUND SYSTEM AMPLIFIER
R5	5.1	24V	561707	FR JCT BOX	CRUISE CTR. STOP SIGN.	R 69					
R6	9.3	24V	561707	RR JCT BOX	STOP LTS-PARKING BRAKE	R 70					
R7	5.1	24V	561707	FR JCT BOX	FAST IDLE	R 71					
R8						R 72					
R9	9.3	24V	561707	RR JCT BOX	BACK-UP LTS	R 73					
R10	4.1	12V	562092	BATT. CPT.	NEUTRAL SIGNAL EATON TRANSM.	R 74					
R11						R 75					
R12	7.2	12V	562092	FR JCT BOX	ELECTRICAL HORNS	R 76					
R13	9.3	24V	561707	FR JCT BOX	FOG LTS	R 77					
R14	9.1	24V	561707	FR JCT BOX	BLINKER	R 78	1.1	12V	562092	FR JCT BOX	MASTER SWITCH
R15	9.1	24V	561707	FR JCT BOX	FR MARKER LTS	R 79	23	24V	561707	GALLEY CPT.	GALLEY-REFRIGERATOR
R16	9.1	24V	561707	FR JCT BOX	IDENT. & CLEARANCE LTS	R 80	11.1	24V	561707	RR JCT BOX	ENGINE COMPARTMENT LTS
R17	9.1	24V	561707	RR JCT BOX	TAIL,LICENCE,MARKER-RR LTS	R 81					
R18	9.1	24V	561707	FR JCT BOX	D R L-PARK BRK CUT-OUT	R 82	19	24V	561707	FR JCT BOX	RETARDER WT
R19	9.1	24V	561707	FR JCT BOX	HEADLAMPS (HI)	R 83					
R20	9.1	24V	561707	FR JCT BOX	HEADLAMPS (LO)	R 84	8	24V	561707	RR JCT BOX	FAN CLUTCH-FIRST SPEED
R21	9.2	24V	561707	FR JCT BOX	L.H. DIRECTIONAL LT	R 85	8	24V	561707	RR JCT BOX	FAN CLUTCH-SECOND SPEED
R22	4.1	24V	561707	BATT. CPT.	NEUTRAL SIGNAL EATON TRANSM.	R 86					
R23	9.2	24V	561707	FR JCT BOX	R.H. DIRECTIONAL LT	R 87	19	24V	561707	RR JCT BOX	ENGINE BRAKE REQUEST WT
R24	9.2	24V	561707	FR JCT BOX	R.H. CORNERING LT	R 88					
R25	9.2	24V	561707	FR JCT BOX	L.H. CORNERING LT	R 89	22	24V	561707	FR JCT BOX	HEATING WINDSHIELD
R26	9.3	24V	561707	RR JCT BOX	STOP LTS	R 90	22	24V	561707	FR JCT BOX	HEATING WINDSHIELD
R27	11.2	24V	561707	RR JCT BOX	AISLE & EMERG.EXIT - LTS	R 91	22	24V	561707	FR JCT BOX	HEATING WINDSHIELD
R28	11.2	24V	561707	FR JCT BOX	DASH LTS RHEOSTAT	R 92	22	24V	561707	FR JCT BOX	HEATING WINDSHIELD
R29	11.3	24V	561707	RR JCT BOX	READING LTS R.H.	R 93	26	24V	561707	RR JCT BOX	PRE-HEAT WATER HEATER (WEBASTO)
R30	11.3	24V	561707	RR JCT BOX	READING LTS L.H.	R 94	25	24V	561707	RR JCT BOX	WCL - SYSTEM
R31	11.3	24V	561707	RR JCT BOX	GENERAL LTS	R 95	25	24V	561707	RR JCT BOX	WCL - MAGNETIC SW. SIGN.
R32	11.4	24V	561707	RR JCT BOX	24V FLUORESCENT	R 96	25	24V	561707	RR JCT BOX	WCL - DOOR AJAR ALARM
R33	4.1	12V	562092	FR JCT BOX	BLOWER CUT-IN RLY	R 97	25	24V	561707	RR JCT BOX	WCL - DOOR AJAR PARK. BRAKE
R34	13.1	24V	561707	RJB A/C JCT PANEL	A/C LOGIC PANEL	R 98	25	12V	561538	RR JCT BOX	WCL -
R35	13.2	24V	561707	RJB A/C JCT PANEL	WATER PUMP	R 99	8	24V	561707	RR JCT BOX	RADIATOR FAN CLUTCH
R36	13.2	24V	561707	RJB A/C JCT PANEL	A/C COMPRESSOR CLUTCH	R 100	4	12V	561538	RR JCT BOX	GENERATOR SIGNAL
R37	9.2	24V	561707	FR JCT BOX	KNEELING LT	R 101					
R38	13.1	24V	561707	RJB A/C JCT PANEL	A/C LIQ. SOL. VALVE	R 102	17	24V	561707	RR JCT BOX	FUEL FILTER HEATER
R39	13.1	24V	561005	BATT. CPT.	CONDENSER FAN MOTOR	R 103					
R40	13.1	24V	561014	BATT. CPT.	CONDENSER SPEED CTR HI	R 104	13.3	24V	561707	RR JCT BOX	HAT-RACK FAN - L.H.
R41	13.1	24V	561005	BATT. CPT.	CONDENSER SPEED CTR HI	R 105	13.3	24V	561707	RR JCT BOX	HAT-RACK FAN - R.H.
R42	6.3	12V	562092	BATT. CPT.	EATON TRANSM.	R 106	17.1	24V	561707	RR JCT BOX	LAVATORY FAN
R43	18.1	24V	561707	FR JCT BOX	KNEELING SYSTEM	R 107					
R44	18.1	24V	561707	FR JCT BOX	KNEELING SYSTEM	R 2010	26.2	24V	561230	WEBASTO PRE-HEAT	WEBASTO
R45						R PS	4.1SP1	24V	561707	FR JCT BOX	IDLE POWER SHUT DOWN
R46						R TS	5.1SP1	24V	561707	FR JCT BOX	IDLE POWER SHUT DOWN
R47	23.1	24V	561707	GALLEY COMPT	GALLEY-LIQUID CONTAINERS	V IMN	6	12V	562092	RR JCT BOX	VIM WORLD TR.-NEUTRAL SIGNAL
R48	23.1	24V	561707	GALLEY COMPT	GALLEY-COFFEE MAKER	V IMR	6	12V	562092	RR JCT BOX	VIM WORLD TR.-BU SIGNAL
R49	21.1	24V	561707	FR JCT BOX	ABS - SERVICE BRK RLY	V IM1	6	12V	562092	RR JCT BOX	VIM WORLD TR.-OUTPUT 1
R50						V IM2	6	12V	562092	RR JCT BOX	VIM WORLD TR.-OUTPUT 2 ENG. BRK DISABLE
R51	11.3	24V	562092	FR JCT BOX	DRIVER'S LTS RLY- ENT. DOOR SIGN.	V IM3	6	12V	562092	RR JCT BOX	VIM WORLD TR.-OUTPUT 3 SPD SW. 5MPH NO NC
R52	21.1	24V	561707	FR JCT BOX	ABS - W/TR SIGN. RETARDER	V IM4	6.1	12V	562092	RR JCT BOX	VIM WORLD TR.-OUTPUT4 RETARD. ON SIGNAL
R53	1.1	24V	561991	RR JCT BOX	ENGINE RUN (24) RR						
R54	1.1	24V	561991	BATT. CPT.	12V CUT OUT RLY RR						
R55	1.1	24V	561991	BATT. CPT.	12V CUT OUT RLY FR						
R56											
R57	9.1	24V	561707	FR JCT BOX	DAY'S BLINKER						



# RELAYS NUMBER CODE

No. PAGE COIL V #PREV. LOCATION FUNCTION

No. PAGE COIL V #PREV. LOCATION FUNCTION

# RELAYS NUMBER CODE

No.	PAGE	COIL V	#PREV.	LOCATION	FUNCTION	No.	PAGE	COIL V	#PREV.	LOCATION	FUNCTION
RF1	8.1	24V	561707	RR JCT BOX	FAN CLUTCH W/RET. SPEED 1	R 58					
RF2	8.1	24V	561707	RR JCT BOX	FAN CLUTCH W/RET. SPEED 2	R 59	9.3	12V	562092	RR JCT BOX	DOCKING LTS
RF3	8.1	24V	560772	RR JCT BOX	TIME DELAY	R 60					
RLA	16.1	24V	561707	UNDER DASH RH.	ENTRANCE DOOR SEDAN (LATCH)	R 61	9.3	24V	561707	RR JCT BOX	STOP LTS-JACOB & RET. SIGNAL
RLO	16.1	24V	561707	UNDER DASH RH.	ENTRANCE DOOR SEDAN (PRESS. SW.)	R 62					
RLT	16.1	24V	561707	UNDER DASH RH.	ENTRANCE DOOR SEDAN (LIGHT)	R 63					
RLV	16.1	24V	561707	UNDER DASH RH.	ENTRANCE DOOR SEDAN (VALVE)	R 64					
R1	1.1	24V	561991	FR JCT BOX	ENGINE RUN (24) FR	R 65					
R2	2.1	24V	561991	BATT. CPT.	ENGINE RUN (12) FR & RR	R 66	20.3	24V	561707	SS JCT PANEL	SOUND SYSTEM VIDEO
R3						R 67	20.1	12V	562092	SS JCT PANEL	SOUND SYSTEM RADIO
R4	4.1	24V	561005	BATT. CPT.	STARTING MOTOR	R 68	20.1	24V	561991	SS JCT PANEL	SOUND SYSTEM AMPLIFIER
R5	5.1	24V	561707	FR JCT BOX	CRUISE CTR. STOP SIGN.	R 69					
R6	9.3	24V	561707	RR JCT BOX	STOP LTS-PARKING BRAKE	R 70					
R7	5.1	24V	561707	FR JCT BOX	FAST IDLE	R 71					
R8						R 72					
R9	9.3	24V	561707	RR JCT BOX	BACK-UP LTS	R 73					
R10	4.1	12V	562092	BATT. CPT.	NEUTRAL SIGNAL EATON TRANSM.	R 74					
R11						R 75					
R12	7.2	12V	562092	FR JCT BOX	ELECTRICAL HORNS	R 76					
R13	9.3	24V	561707	FR JCT BOX	FOG LTS	R 77					
R14	9.1	24V	561707	FR JCT BOX	BLINKER	R 78	1.1	12V	562092	FR JCT BOX	MASTER SWITCH
R15	9.1	24V	561707	FR JCT BOX	FR MARKER LTS	R 79	23	24V	561707	GALLEY CPT.	GALLEY-REFRIGERATOR
R16	9.1	24V	561707	FR JCT BOX	IDENT. & CLEARANCE LTS	R 80	11.1	24V	561707	RR JCT BOX	ENGINE COMPARTMENT LTS
R17	9.1	24V	561707	RR JCT BOX	TAIL,LICENCE,MARKER-RR LTS	R 81					
R18	9.1	24V	561707	FR JCT BOX	D R L-PARK BRK CUT-OUT	R 82	19	24V	561707	FR JCT BOX	RETARDER WT
R19	9.1	24V	561707	FR JCT BOX	HEADLAMPS (HI)	R 83					
R20	9.1	24V	561707	FR JCT BOX	HEADLAMPS (LO)	R 84	8	24V	561707	RR JCT BOX	FAN CLUTCH-FIRST SPEED
R21	9.2	24V	561707	FR JCT BOX	L.H. DIRECTIONAL LT	R 85	8	24V	561707	RR JCT BOX	FAN CLUTCH-SECOND SPEED
R22	4.1	24V	561707	BATT. CPT.	NEUTRAL SIGNAL EATON TRANSM.	R 86					
R23	9.2	24V	561707	FR JCT BOX	R.H. DIRECTIONAL LT	R 87	19	24V	561707	RR JCT BOX	ENGINE BRAKE REQUEST WT
R24	9.2	24V	561707	FR JCT BOX	R.H. CORNERING LT	R 88					
R25	9.2	24V	561707	FR JCT BOX	L.H. CORNERING LT	R 89	22	24V	561707	FR JCT BOX	HEATING WINDSHIELD
R26	9.3	24V	561707	RR JCT BOX	STOP LTS	R 90	22	24V	561707	FR JCT BOX	HEATING WINDSHIELD
R27	11.2	24V	561707	RR JCT BOX	AISLE & EMERG.EXIT - LTS	R 91	22	24V	561707	FR JCT BOX	HEATING WINDSHIELD
R28	11.2	24V	561707	FR JCT BOX	DASH LTS RHEOSTAT	R 92	22	24V	561707	FR JCT BOX	HEATING WINDSHIELD
R29	11.3	24V	561707	RR JCT BOX	READING LTS R.H.	R 93	26	24V	561707	RR JCT BOX	PRE-HEAT WATER HEATER (WEBASTO)
R30	11.3	24V	561707	RR JCT BOX	READING LTS L.H.	R 94	25	24V	561707	RR JCT BOX	WCL - SYSTEM
R31	11.3	24V	561707	RR JCT BOX	GENERAL LTS	R 95	25	24V	561707	RR JCT BOX	WCL - MAGNETIC SW. SIGN.
R32	11.4	24V	561707	RR JCT BOX	24V FLUORESCENT	R 96	25	24V	561707	RR JCT BOX	WCL - DOOR AJAR ALARM
R33	4.1	12V	562092	FR JCT BOX	BLOWER CUT-IN RLY	R 97	25	24V	561707	RR JCT BOX	WCL - DOOR AJAR PARK. BRAKE
R34	13.1	24V	561707	RJB A/C JCT PANEL	A/C LOGIC PANEL	R 98	25	12V	561538	RR JCT BOX	WCL -
R35	13.2	24V	561707	RJB A/C JCT PANEL	WATER PUMP	R 99	8	24V	561707	RR JCT BOX	RADIATOR FAN CLUTCH
R36	13.2	24V	561707	RJB A/C JCT PANEL	A/C COMPRESSOR CLUTCH	R 100	4	12V	561538	RR JCT BOX	GENERATOR SIGNAL
R37	9.2	24V	561707	FR JCT BOX	KNEELING LT	R 101					
R38	13.1	24V	561707	RJB A/C JCT PANEL	A/C LIQ. SOL. VALVE	R 102	17	24V	561707	RR JCT BOX	FUEL FILTER HEATER
R39	13.1	24V	561005	BATT. CPT.	CONDENSER FAN MOTOR	R 103	13.3	24V	561707	RR JCT BOX	LAVATORY FLUORESCENT
R40	13.1	24V	561014	BATT. CPT.	CONDENSER SPEED CTR HI	R 104	13.3	24V	561707	RR JCT BOX	HAT-RACK FAN
R41	13.1	24V	561005	BATT. CPT.	CONDENSER SPEED CTR HI	R 105	13.3	24V	561707	RR JCT BOX	HAT-RACK FAN - L.H.
R42	6.3	12V	562092	BATT. CPT.	EATON TRANSM.	R 106	17.1	24V	561707	RR JCT BOX	HAT-RACK FAN - R.H.
R43	18.1	24V	561707	FR JCT BOX	KNEELING SYSTEM	R 107					
R44	18.1	24V	561707	FR JCT BOX	KNEELING SYSTEM	R 107					
R45						R 2010	26.2	24V	561230	WEBASTO PRE-HEAT	WEBASTO
R46						R PS	4.1SP1	24V	561707	FR JCT BOX	IDLE POWER SHUT DOWN
R47	23.1	24V	561707	GALLEY COMPT	GALLEY-LIQUID CONTAINERS	R TS	5.1SP1	24V	561707	FR JCT BOX	IDLE POWER SHUT DOWN
R48	23.1	24V	561707	GALLEY COMPT	GALLEY-COFFEE MAKER	V IMN	6	12V	562092	RR JCT BOX	VIM WORLD TR.-NEUTRAL SIGNAL
R49	21.1	24V	561707	FR JCT BOX	ABS - SERVICE BRK RLY	V IMR	6	12V	562092	RR JCT BOX	VIM WORLD TR.-BU SIGNAL
R50						V IM1	6	12V	562092	RR JCT BOX	VIM WORLD TR.-OUTPUT 1
R51	11.3	24V	562092	FR JCT BOX	DRIVER'S LTS RLY- ENT. DOOR SIGN.	V IM2	6	12V	562092	RR JCT BOX	VIM WORLD TR.-OUTPUT 2 ENG. BRK DISABLE
R52	21.1	24V	561707	FR JCT BOX	ABS - W/TR SIGN. RETARDER	V IM3	6	12V	562092	RR JCT BOX	VIM WORLD TR.-OUTPUT 3 SPD SW. 5MPH NO NC
R53	1.1	24V	561991	RR JCT BOX	ENGINE RUN (24) RR	V IM4	6.1	12V	562092	RR JCT BOX	VIM WORLD TR.-OUTPUT4 RETARD. ON SIGNAL
R54	1.1	24V	561991	BATT. CPT.	12V CUT OUT RLY RR						
R55	1.1	24V	561991	BATT. CPT.	12V CUT OUT RLY FR						
R56											
R57	9.1	24V	561707	FR JCT BOX	DAY'S BLINKER						

# RELAYS NUMBER CODE

No. PAGE COIL V #PREV. LOCATION FUNCTION

No. PAGE COIL V #PREV. LOCATION FUNCTION

# RELAYS NUMBER CODE

No.	PAGE	COIL V	#PREV.	LOCATION	FUNCTION	No.	PAGE	COIL V	#PREV.	LOCATION	FUNCTION
RF1	8.1	24V	561707	RR JCT BOX	FAN CLUTCH W/RET. SPEED 1	R 59	9.3	12V	562092	RR JCT BOX	DOCKING LTS
RF2	8.1	24V	561707	RR JCT BOX	FAN CLUTCH W/RET. SPEED 2	R 60					
RF3	8.1	24V	560772	RR JCT BOX	TIME DELAY	R 61	9.3	24V	561707	RR JCT BOX	STOP LTS-JACOB & RET. SIGNAL
RLA	16.1	24V	561707	UNDER DASH RH.	ENTRANCE DOOR SEDAN (LATCH)	R 62					
RLO	16.1	24V	561707	UNDER DASH RH.	ENTRANCE DOOR SEDAN (PRESS. SW.)	R 63					
RLT	16.1	24V	561707	UNDER DASH RH.	ENTRANCE DOOR SEDAN (LIGHT)	R 64					
RLV	16.1	24V	561707	UNDER DASH RH.	ENTRANCE DOOR SEDAN (VALVE)	R 65					
R 1	1.1	24V	561991	FR JCT BOX	ENGINE RUN (24) FR	R 66	20.3	24V	561707	SS JCT PANEL	SOUND SYSTEM VIDEO
R 2	2.1	24V	561991	BATT. CPT.	ENGINE RUN (12) FR & RR	R 67	20.1	12V	562092	SS JCT PANEL	SOUND SYSTEM RADIO
R 3						R 68	20.1	24V	561991	SS JCT PANEL	SOUND SYSTEM AMPLIFIER
R 4	4.1	24V	561005	BATT. CPT.	STARTING MOTOR	R 69					
R 5	5.1	24V	561707	FR JCT BOX	CRUISE CTR. STOP SIGN.	R 70					
R 6	9.3	24V	561707	RR JCT BOX	STOP LTS-PARKING BRAKE	R 71					
R 7	5.1	24V	561707	FR JCT BOX	FAST IDLE	R 72					
R 8						R 73					
R 9	9.3	24V	561707	RR JCT BOX	BACK-UP LTS	R 74					
R 10	4.1	12V	562092	BATT. CPT.	NEUTRAL SIGNAL EATON TRANSM.	R 75					
R 11						R 76					
R 12	7.2	12V	562092	FR JCT BOX	ELECTRICAL HORNS	R 77					
R 13	9.3	24V	561707	FR JCT BOX	FOG LTS	R 78	1.1	12V	562092	FR JCT BOX	MASTER SWITCH
R 14	9.1	24V	561707	FR JCT BOX	BLINKER	R 79	23	24V	561707	GALLEY CPT.	GALLEY-REFRIGERATOR
R 15	9.1	24V	561707	FR JCT BOX	FR MARKER LTS	R 80	11.1	24V	561707	RR JCT BOX	ENGINE COMPARTMENT LTS
R 16	9.1	24V	561707	FR JCT BOX	IDENT. & CLEARANCE LTS	R 81					
R 17	9.1	24V	561707	RR JCT BOX	TAIL,LICENCE,MARKER-RR LTS	R 82	19	24V	561707	FR JCT BOX	RETARDER WT
R 18	9.1	24V	561707	FR JCT BOX	D R L-PARK BRK CUT-OUT	R 83					
R 19	9.1	24V	561707	FR JCT BOX	HEADLAMPS (HI)	R 84	8	24V	561707	RR JCT BOX	FAN CLUTCH-FIRST SPEED
R 20	9.1	24V	561707	FR JCT BOX	HEADLAMPS (LO)	R 85	8	24V	561707	RR JCT BOX	FAN CLUTCH-SECOND SPEED
R 21	9.2	24V	561707	FR JCT BOX	L.H. DIRECTIONNAL LT	R 86					
R 22	4.1	24V	561707	BATT. CPT.	NEUTRAL SIGNAL EATON TRANSM.	R 87	19	24V	561707	RR JCT BOX	ENGINE BRAKE REQUEST WT
R 23	9.2	24V	561707	FR JCT BOX	R.H. DIRECTIONNAL LT	R 88					
R 24	9.2	24V	561707	FR JCT BOX	R.H. CORNERING LT	R 89	22	24V	561707	FR JCT BOX	HEATING WINDSHIELD
R 25	9.2	24V	561707	FR JCT BOX	L.H. CORNERING LT	R 90	22	24V	561707	FR JCT BOX	HEATING WINDSHIELD
R 26	9.3	24V	561707	RR JCT BOX	STOP LTS	R 91	22	24V	561707	FR JCT BOX	HEATING WINDSHIELD
R 27	11.2	24V	561707	RR JCT BOX	AISLE & EMERG.EXIT - LTS	R 92	22	24V	561707	FR JCT BOX	HEATING WINDSHIELD
R 28	11.2	24V	561707	FR JCT BOX	DASH LTS RHEOSTAT	R 93	26	24V	561707	RR JCT BOX	PRE-HEAT WATER HEATER (WEBASTO)
R 29	11.3	24V	561707	RR JCT BOX	READING LTS R.H.	R 94	25	24V	561707	RR JCT BOX	WCL - SYSTEM
R 30	11.3	24V	561707	RR JCT BOX	READING LTS L.H.	R 95	25	24V	561707	RR JCT BOX	WCL - MAGNETIC SW. SIGN.
R 31	11.3	24V	561707	RR JCT BOX	GENERAL LTS	R 96	25	24V	561707	RR JCT BOX	WCL - DOOR AJAR ALARM
R 32	11.4	24V	561707	RR JCT BOX	24V FLUORESCENT	R 97	25	24V	561707	RR JCT BOX	WCL - DOOR AJAR PARK. BRAKE
R 34	13.1	24V	561707	RJB A/C JCT PANEL	A/C LOGIC PANEL	R 98	25	24V	561707	RR JCT BOX	WCL -ALTERNATOR SIGNAL
R 35	13.2	24V	561707	RJB A/C JCT PANEL	WATER PUMP	R 99	8	24V	561707	RR JCT BOX	RADIATOR FAN CLUTCH
R 36	13.2	24V	561707	RJB A/C JCT PANEL	A/C COMPRESSOR CLUTCH	R 100					
R 37	9.2	24V	561707	FR JCT BOX	KNEELING LT	R 101				RR JCT BOX	FUEL FILTER HEATER
R 38	13.1	24V	561707	RJB A/C JCT PANEL	A/C LIQ. SOL. VALVE	R 102	17	24V	561707	RR JCT BOX	LAVATORY FLUORESCENT
R 39	13.1	24V	561005	BATT. CPT.	CONDENSER FAN MOTOR	R 103	13.3	24V	561707	RR JCT BOX	HAT-RACK FAN
R 40	13.1	24V	561014	BATT. CPT.	CONDENSER SPEED CTR HI	R 104	13.3	24V	561707	RR JCT BOX	HAT-RACK FAN - L.H.
R 41	13.1	24V	561005	BATT. CPT.	CONDENSER SPEED CTR HI	R 105	13.3	24V	561707	RR JCT BOX	HAT-RACK FAN - R.H.
R 42	6.3	12V	562092	BATT. CPT.	EATON TRANSM.	R 106	17.1	24V	561707	RR JCT BOX	LAVATORY FAN
R 43	18.1	24V	561707	FR JCT BOX	KNEELING SYSTEM	R 107					
R 44	18.1	24V	561707	FR JCT BOX	KNEELING SYSTEM	R 2010	26.2	24V	561230	WEBASTO PRE-HEAT	WEBASTO
R 45						RA1	4.2	24V	561707	RR JCT BOX	PRE-EXITATION RELAY BOSCH ALT.
R 46						RA2	4.2	24V	561707	RR JCT BOX	PRE-EXITATION RELAY BOSCH ALT.
R 47	23.1	24V	561707	GALLEY COMPT	GALLEY-LIQUID CONTAINERS	RA3	4.2	24V	561707	RR JCT BOX	ALT. 1 OR ALT.2 RUN RELAY
R 48	23.1	24V	561707	GALLEY COMPT	GALLEY-COFFEE MAKER	RA4	4.2	24V	561707	RR JCT BOX	ALT. 1 AND ALT. 2 RUN RELAY
R 49	21.1	24V	561707	FR JCT BOX	ABS - SERVICE BRK RLY	R PS	4.1SP1	24V	561707	FR JCT BOX	IDLE POWER SHUT DOWN
R 50						R TS	5.1SP1	24V	561707	FR JCT BOX	IDLE POWER SHUT DOWN
R 51	11.3	24V	562092	FR JCT BOX	DRIVER'S LTS RLY- ENT. DOOR SIGN.	V IMN	6	12V	562092	RR JCT BOX	VIM WORLD TR.-NEUTRAL SIGNAL
R 52	21.1	24V	561707	FR JCT BOX	ABS - W/TR SIGN. RETARDER	V IMR	6	12V	562092	RR JCT BOX	VIM WORLD TR.-BU SIGNAL
R 53	1.1	24V	561991	RR JCT BOX	ENGINE RUN (24) RR	V IM1	6	12V	562092	RR JCT BOX	VIM WORLD TR.-OUTPUT 1
R 54	1.1	24V	561991	BATT. CPT.	12V CUT OUT RLY RR	V IM2	6	12V	562092	RR JCT BOX	VIM WORLD TR.-OUTPUT 2 ENG. BRK DISABLE
R 55	1.1	24V	561991	BATT. CPT.	12V CUT OUT RLY FR	V IM3	6	12V	562092	RR JCT BOX	VIM WORLD TR.-OUTPUT 3 SPD SW. 5MPH NO NC
R 56						V IM4	6.1	12V	562092	RR JCT BOX	VIM WORLD TR.-OUTPUT4 RETARD. ON SIGNAL
R 57	9.1	24V	561707	FR JCT BOX	DAY'S BLINKER						
R 58											

# RELAYS NUMBER CODE

No. PAGE COIL V #PREV. LOCATION FUNCTION

No. PAGE COIL V #PREV. LOCATION FUNCTION

## RESISTORS NUMBER CODE

No.	PAGE	OHM(S)	#PREV.	LOCATION	FUNCTION
RS1	5	11 K	561898	FR JCT BOX	FAST IDLE DDEC CONTROL
RS2	5	3.6 K	561897	FR JCT BOX	FAST IDLE DDEC CONTROL
RS3	9.3	1 (2)	561537	FR JCT BOX	FOG LT - RH
RS4	9.3	1 (2)	561537	FR JCT BOX	FOG LT - LH
RS5	9.2	1 (2)	061976	FR JCT BOX	CORNERING LT - LH
RS7	9.3	.82 (2)	060806	RR JCT BOX	PARKING BRAKE STOP LTS
RS8	9.2	1 (2)	061976	FR JCT BOX	CORNERING LT - RH
RS11	22	12	561191	FR TOP	DEFROSTER SPEED
RS12	22	12	561191	FR TOP	DEFROSTER SPEED
RS13	17	80 (2)	562108	FR TOP	FR DESTINATION SIGN
RS9	9.3	1 (2)	061976	RR JCT BOX	DOCKING LT - RH
RS10	9.3	1 (2)	061976	RR JCT BOX	DOCKING LT - LH
RS17	7	220	562498	FR JCT BOX	FIRE ALARM
RS18	8	75 K	064208	RR JCT BOX	FAN CLUTCH W/RETARDER
RS20	15	1 K	562470	RR JCT BOX	WORLD TR. SPEED TO DDEC III



## RESISTORS NUMBER CODE

No.	PAGE	OHM(S)	#PREV.	LOCATION	FUNCTION
RS 1	5	11 K	561898	FR JCT BOX	FAST IDLE DDEC CONTROL
RS 2	5	3.6 K	561897	FR JCT BOX	FAST IDLE DDEC CONTROL
RS 3	9.3	1 (2)	561537	FR JCT BOX	FOG LT - RH
RS 4	9.3	1 (2)	561537	FR JCT BOX	FOG LT - LH
RS 5	9.2	1 (2)	061976	FR JCT BOX	CORNERING LT - LH
RS 7	9.3	.82 (2)	060806	RR JCT BOX	PARKING BRAKE STOP LTS
RS 8	9.2	1 (2)	061976	FR JCT BOX	CORNERING LT - RH
RS 11	22	12	561191	FR TOP	DEFROSTER SPEED
RS 12	22	12	561191	FR TOP	DEFROSTER SPEED
RS 13	17	80 (2)	562108	FR TOP	FR DESTINATION SIGN
RS 9	9.3	1 (2)	061976	RR JCT BOX	DOCKING LT - RH
RS 10	9.3	1 (2)	061976	RR JCT BOX	DOCKING LT - LH
RS 17	7	220	562498	FR JCT BOX	FIRE ALARM
RS 18	8	75 K	064208	RR JCT BOX	FAN CLUTCH W/RETARDER
RS 20	15	1 K	562470	RR JCT BOX	WORLD TR. SPEED TO DDEC III
RS 21	22	1K	562470	DASH	DIVIDER VOLTAGE FOR LED
RS 24	9.1	1K	562470	DASH	DIVIDER VOLTAGE FOR LED
RS 25	9.3	1K	562470	DASH	DIVIDER VOLTAGE FOR LED
RS 26	10	1K	562470	DASH	DIVIDER VOLTAGE FOR LED
RS 28	26.1	1K	562470	DASH	DIVIDER VOLTAGE FOR LED

## RESISTORS NUMBER CODE

No.	PAGE	OHM(S)	#PREV.	LOCATION	FUNCTION
RS 1	5	11 K	561898	FR JCT BOX	FAST IDLE DDEC CONTROL
RS 2	5	3.6 K	561897	FR JCT BOX	FAST IDLE DDEC CONTROL
RS 3	9.3	1 (2)	561537	FR JCT BOX	FOG LT - RH
RS 4	9.3	1 (2)	561537	FR JCT BOX	FOG LT - LH
RS 5	9.2	1 (2)	061976	FR JCT BOX	CORNERING LT - LH
RS 7	9.3	.82 (2)	060806	RR JCT BOX	PARKING BRAKE STOP LTS
RS 8	9.2	1 (2)	061976	FR JCT BOX	CORNERING LT - RH
RS 11	22	12	561191	FR TOP	DEFROSTER SPEED
RS 12	22	12	561191	FR TOP	DEFROSTER SPEED
RS 13	17	80 (2)	562108	FR TOP	FR DESTINATION SIGN
RS 9	9.3	1 (2)	061976	RR JCT BOX	DOCKING LT - RH
RS 10	9.3	1 (2)	061976	RR JCT BOX	DOCKING LT - LH
RS 17	7	220	562498	FR JCT BOX	FIRE ALARM
RS 18	8	75 K	064208	RR JCT BOX	FAN CLUTCH W/RETARDER
RS 20	15	1 K	562470	RR JCT BOX	WORLD TR. SPEED TO DDEC III
RS 21	22	1K	562470	DASH	DIVIDER VOLTAGE FOR LED
RS 24	9.1	1K	562470	DASH	DIVIDER VOLTAGE FOR LED
RS 25	9.3	1K	562470	DASH	DIVIDER VOLTAGE FOR LED
RS 26	10	1K	562470	DASH	DIVIDER VOLTAGE FOR LED
RS 28	26.1	1K	562470	DASH	DIVIDER VOLTAGE FOR LED
RS 29	23.1	1K	562470	GALLEY	DIVIDER VOLTAGE FOR LED
RS 30	23.1	1K	562470	GALLEY	DIVIDER VOLTAGE FOR LED
RS 31	23.1	1K	562470	GALLEY	DIVIDER VOLTAGE FOR LED

## RESISTORS NUMBER CODE

No.	PAGE	OHM(S)	#PREV.	LOCATION	FUNCTION
RS 1	5	11 K	561898	FR JCT BOX	FAST IDLE DDEC CONTROL
RS 2	5	3.6 K	561897	FR JCT BOX	FAST IDLE DDEC CONTROL
RS 3	9.3	1 (2)	561537	FR JCT BOX	FOG LT - RH
RS 4	9.3	1 (2)	561537	FR JCT BOX	FOG LT - LH
RS 5	9.2	1 (2)	061976	FR JCT BOX	CORNERING LT - LH
RS 7	9.3	.82 (2)	060806	RR JCT BOX	PARKING BRAKE STOP LTS
RS 8	9.2	1 (2)	061976	FR JCT BOX	CORNERING LT - RH
RS 11	22	12	561191	FR TOP	DEFROSTER SPEED
RS 12	22	12	561191	FR TOP	DEFROSTER SPEED
RS 13	17	80 (2)	562108	FR TOP	FR DESTINATION SIGN
RS 9	9.3	1 (2)	061976	RR JCT BOX	DOCKING LT - RH
RS 10	9.3	1 (2)	061976	RR JCT BOX	DOCKING LT - LH
RS 17	7	220	562498	FR JCT BOX	FIRE ALARM
RS 18	8	75 K	064208	RR JCT BOX	FAN CLUTCH W/RETARDER
RS 20	15	1 K	562470	RR JCT BOX	WORLD TR. SPEED TO DDEC III
RS 21	22	15K	562908	DASH	CURRENT LIMIT FOR LED
RS 24	9.1	1.5K	562908	DASH	CURRENT LIMIT FOR LED
RS 25	9.3	1.5K	562908	DASH	CURRENT LIMIT FOR LED
RS 26	10	1.5K	562908	DASH	CURRENT LIMIT FOR LED
RS 28	26.1	1.5K	562908	DASH	CURRENT LIMIT FOR LED
RS 29	23.1	1.5K	562908	GALLEY	CURRENT LIMIT FOR LED
RS 30	23.1	1.5K	562908	GALLEY	CURRENT LIMIT FOR LED
RS 31	23.1	1.5K	562908	GALLEY	CURRENT LIMIT FOR LED
RS 32	13.3	1.5K	562908	DASH	CURRENT LIMIT FOR LED
RS 33	23.1	1.5K	562908	GALLEY	CURRENT LIMIT FOR LED
RS 34	23.1	1.5K	562908	GALLEY	CURRENT LIMIT FOR LED
RS 35	23.1	1.5K	562908	GALLEY	CURRENT LIMIT FOR LED

## RESISTORS NUMBER CODE

No.	PAGE	OHM(S)	#PREV.	LOCATION	FUNCTION
RS 1	5	11 K	561898	FR JCT BOX	FAST IDLE DDEC CONTROL
RS 2	5	3.6 K	561897	FR JCT BOX	FAST IDLE DDEC CONTROL
RS 3	9.3	1 (2)	561537	FR JCT BOX	FOG LT - RH
RS 4	9.3	1 (2)	561537	FR JCT BOX	FOG LT - LH
RS 5	9.2	1 (2)	061976	FR JCT BOX	CORNERING LT - LH
RS 7	9.3	.82 (2)	060806	RR JCT BOX	PARKING BRAKE STOP LTS
RS 8	9.2	1 (2)	061976	FR JCT BOX	CORNERING LT - RH
RS 11	22	12	561191	FR TOP	DEFROSTER SPEED
RS 12	22	12	561191	FR TOP	DEFROSTER SPEED
RS 13	17	80 (2)	562108	FR TOP	FR DESTINATION SIGN
RS 9	9.3	1 (2)	061976	RR JCT BOX	DOCKING LT - RH
RS 10	9.3	1 (2)	061976	RR JCT BOX	DOCKING LT - LH
RS 17	7	220	562498	FR JCT BOX	FIRE ALARM
RS 18	8	75 K	064208	RR JCT BOX	FAN CLUTCH W/RETARDER
RS 20	15	1 K	562470	RR JCT BOX	WORLD TR. SPEED TO DDEC III
RS 21	22	15K	562908	DASH	CURRENT LIMIT FOR LED
RS 24	9.1	1.5K	562908	DASH	CURRENT LIMIT FOR LED
RS 25	9.3	1.5K	562908	DASH	CURRENT LIMIT FOR LED
RS 26	10	1.5K	562908	DASH	CURRENT LIMIT FOR LED
RS 28	26.1	1.5K	562908	DASH	CURRENT LIMIT FOR LED
RS 29	23.1	1.5K	562908	GALLEY	CURRENT LIMIT FOR LED
RS 30	23.1	1.5K	562908	GALLEY	CURRENT LIMIT FOR LED
RS 31	23.1	1.5K	562908	GALLEY	CURRENT LIMIT FOR LED
RS 32	13.3	1.5K	562908	DASH	CURRENT LIMIT FOR LED
RS 33	23.1	1.5K	562908	GALLEY	CURRENT LIMIT FOR LED
RS 34	23.1	1.5K	562908	GALLEY	CURRENT LIMIT FOR LED
RS 35	23.1	1.5K	562908	GALLEY	CURRENT LIMIT FOR LED
RS 36	13.1	10	064907	BATT. COMPT.	CURRENT LIMIT FOR RELAY
RS 37	13.1	5	064907	BATT. COMPT.	CURRENT LIMIT FOR RELAY

## RESISTORS NUMBER CODE

No.	PAGE	OHM(S)	#PREV.	LOCATION	FUNCTION
RS 1	5	11 K	561898	FR JCT BOX	FAST IDLE DDEC CONTROL
RS 2	5	3.6 K	561897	FR JCT BOX	FAST IDLE DDEC CONTROL
RS 3	9.3	1 (2)	561537	FR JCT BOX	FOG LT - RH
RS 4	9.3	1 (2)	561537	FR JCT BOX	FOG LT - LH
RS 5	9.2	1 (2)	061976	FR JCT BOX	CORNERING LT - LH
RS 7	9.3	.82 (2)	060806	RR JCT BOX	PARKING BRAKE STOP LTS
RS 8	9.2	1 (2)	061976	FR JCT BOX	CORNERING LT - RH
RS 11	22	12	561191	FR TOP	DEFROSTER SPEED
RS 12	22	12	561191	FR TOP	DEFROSTER SPEED
RS 13	17	80 (2)	562108	FR TOP	FR DESTINATION SIGN
RS 9	9.3	1 (2)	061976	RR JCT BOX	DOCKING LT - RH
RS 10	9.3	1 (2)	061976	RR JCT BOX	DOCKING LT - LH
RS 17	7	220	562498	FR JCT BOX	FIRE ALARM
RS 18	8	75 K	064208	RR JCT BOX	FAN CLUTCH W/RETARDER
RS 20	15	1 K	562470	RR JCT BOX	WORLD TR. SPEED TO DDEC III
RS 21	22	15K	562908	DASH	CURRENT LIMIT FOR LED
RS 24	9.1	1.5K	562908	DASH	CURRENT LIMIT FOR LED
RS 25	9.3	1.5K	562908	DASH	CURRENT LIMIT FOR LED
RS 26	10	1.5K	562908	DASH	CURRENT LIMIT FOR LED
RS 28	26.1	1.5K	562908	DASH	CURRENT LIMIT FOR LED
RS 29	23.1	1.5K	562908	GALLEY	CURRENT LIMIT FOR LED
RS 30	23.1	1.5K	562908	GALLEY	CURRENT LIMIT FOR LED
RS 31	23.1	1.5K	562908	GALLEY	CURRENT LIMIT FOR LED
RS 32	13.3	1.5K	562908	DASH	CURRENT LIMIT FOR LED
RS 33	4.2	30	562948	RR JCT BOX	CURRENT LOAD FOR RELAY CONTACT
RS 33	23.1	1.5K	562908	GALLEY	CURRENT LIMIT FOR LED
RS 34	23.1	1.5K	562908	GALLEY	CURRENT LIMIT FOR LED
RS 35	23.1	1.5K	562908	GALLEY	CURRENT LIMIT FOR LED
RS 36	13.1	10	064907	BATT. COMPT.	CURRENT LIMIT FOR RELAY
RS 37	13.1	5	064907	BATT. COMPT.	CURRENT LIMIT FOR RELAY

## RESISTORS NUMBER CODE

No.	PAGE	OHM(S)	#PREV.	LOCATION	FUNCTION
RS 1	5	11 K	561898	FR JCT BOX	FAST IDLE DDEC CONTROL
RS 2	5	3.6 K	561897	FR JCT BOX	FAST IDLE DDEC CONTROL
RS 3	9.3	1 (2)	561537	FR JCT BOX	FOG LT - RH
RS 4	9.3	1 (2)	561537	FR JCT BOX	FOG LT - LH
RS 5	9.2	1 (2)	061976	FR JCT BOX	CORNERING LT - LH
RS 6	16.1	5	563006	RH UNDER DASH	VOLTAGE DIV. OPEN DOOR SOL.
RS 7	9.3	.82 (2)	060806	RR JCT BOX	PARKING BRAKE STOP LTS
RS 8	9.2	1 (2)	061976	FR JCT BOX	CORNERING LT - RH
RS 11	22	12	561191	FR TOP	DEFROSTER SPEED
RS 12	22	12	561191	FR TOP	DEFROSTER SPEED
RS 13	17	80 (2)	562108	FR TOP	FR DESTINATION SIGN
RS 9	9.3	1 (2)	061976	RR JCT BOX	DOCKING LT - RH
RS 10	9.3	1 (2)	061976	RR JCT BOX	DOCKING LT - LH
RS 17	7	220	562498	FR JCT BOX	FIRE ALARM
RS 18	8	75 K	064208	RR JCT BOX	FAN CLUTCH W/RETARDER
RS 20	15	1 K	562470	RR JCT BOX	WORLD TR. SPEED TO DDEC III
RS 21	22	15K	562908	DASH	CURRENT LIMIT FOR LED
RS 24	9.1	1.5K	562908	DASH	CURRENT LIMIT FOR LED
RS 25	9.3	1.5K	562908	DASH	CURRENT LIMIT FOR LED
RS 26	10	1.5K	562908	DASH	CURRENT LIMIT FOR LED
RS 28	26.1	1.5K	562908	DASH	CURRENT LIMIT FOR LED
RS 29	23.1	1.5K	562908	GALLEY	CURRENT LIMIT FOR LED
RS 30	23.1	1.5K	562908	GALLEY	CURRENT LIMIT FOR LED
RS 31	23.1	1.5K	562908	GALLEY	CURRENT LIMIT FOR LED
RS 32	13.3	1.5K	562908	DASH	CURRENT LIMIT FOR LED
RS 33	4.2	30	562948	RR JCT BOX	CURRENT LOAD FOR RELAY CONTACT
RS 33	23.1	1.5K	562908	GALLEY	CURRENT LIMIT FOR LED
RS 34	23.1	1.5K	562908	GALLEY	CURRENT LIMIT FOR LED
RS 35	23.1	1.5K	562908	GALLEY	CURRENT LIMIT FOR LED
RS 36	13.1	10	064907	BATT. COMPT.	CURRENT LIMIT FOR RELAY
RS 37	13.1	5	064907	BATT. COMPT.	CURRENT LIMIT FOR RELAY



# WIRING DIAGRAM KEYS

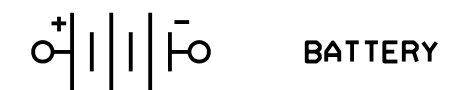
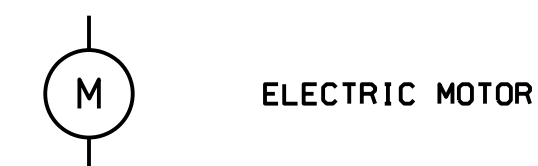
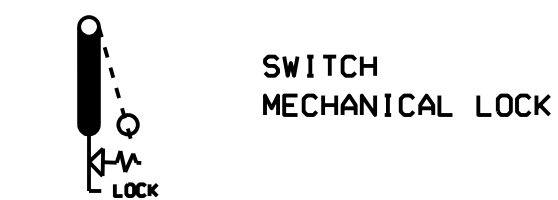
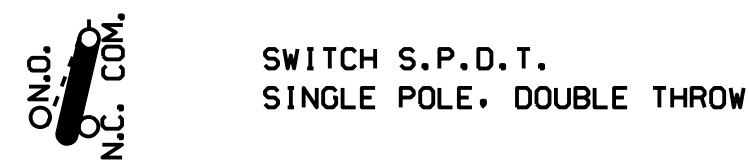
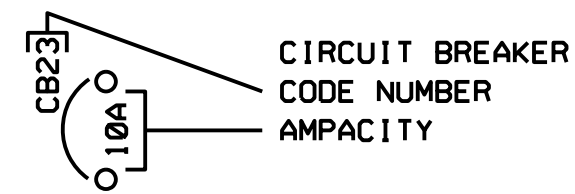
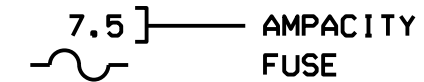
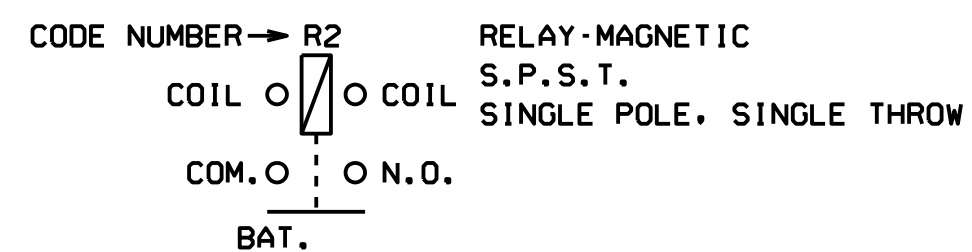
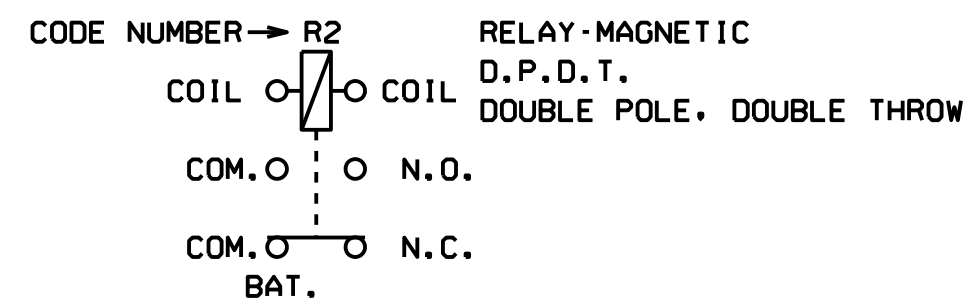
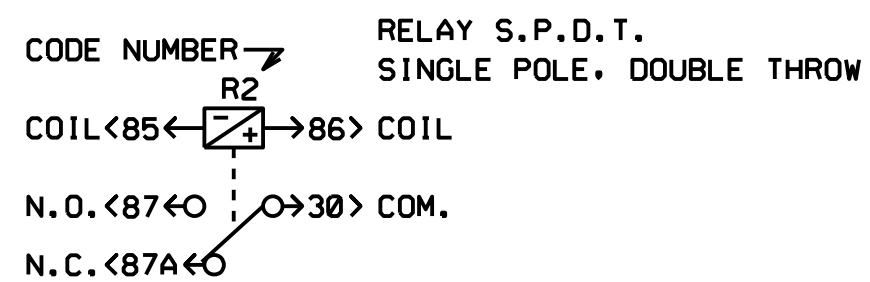
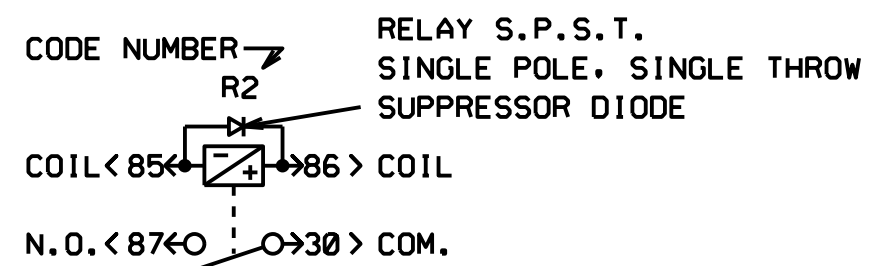
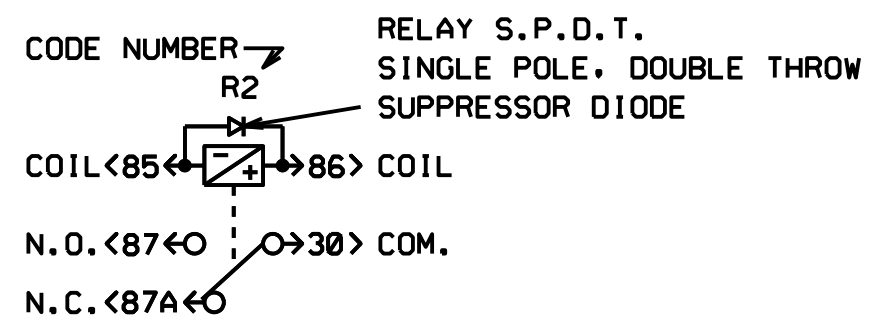
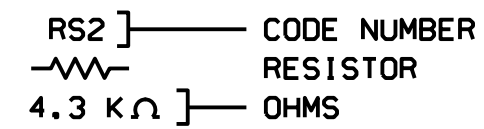
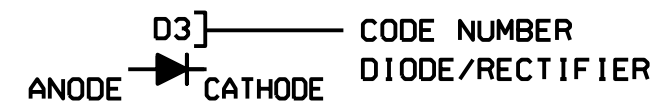
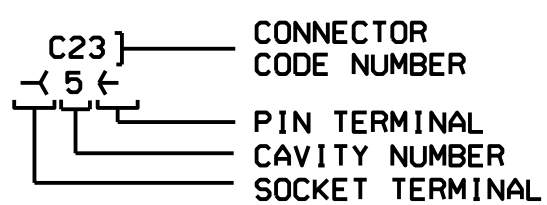
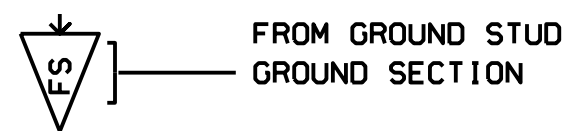
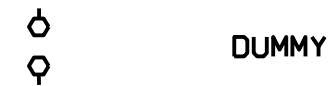
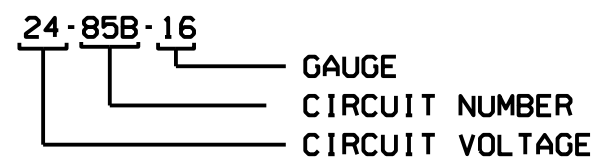

- |     |        |
|-----|--------|
| BLK | BLACK  |
| YEL | YELLOW |
| RED | RED    |
| WH  | WHITE  |
| GRY | GREY   |
| ORA | ORANGE |
| BLU | BLUE   |
| GRN | GREEN  |
| BRN | BROWN  |
| PUR | PURPLE |
| PK  | PINK   |

# WIRING DIAGRAM KEYS

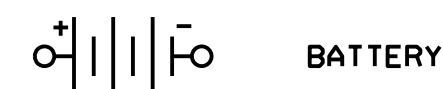
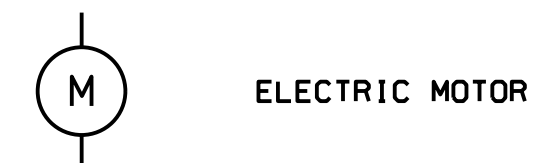
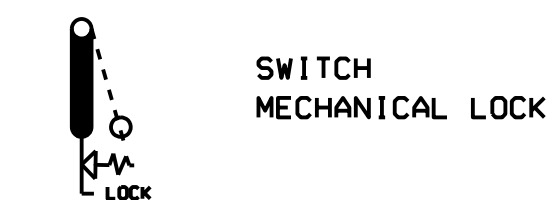
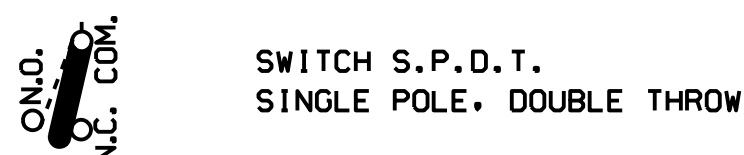
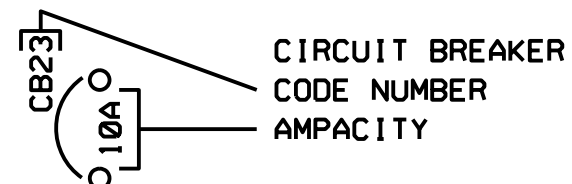
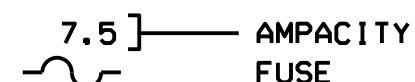
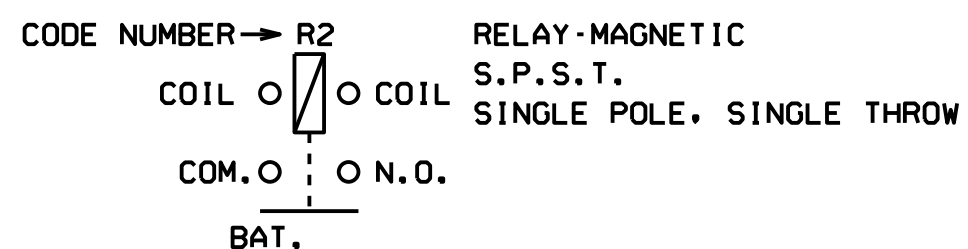
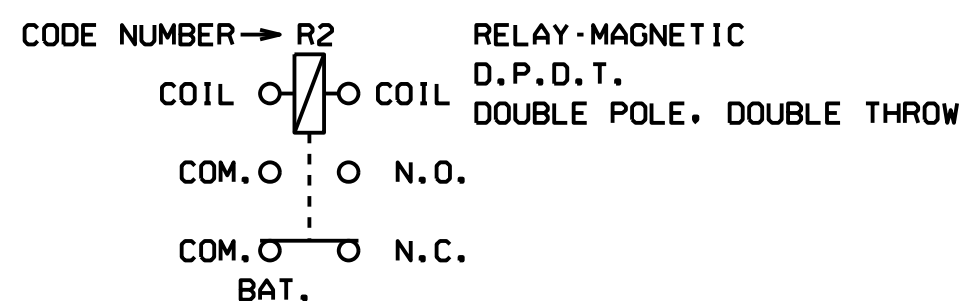
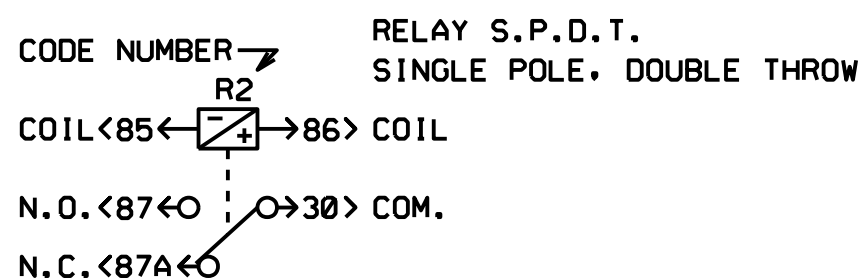
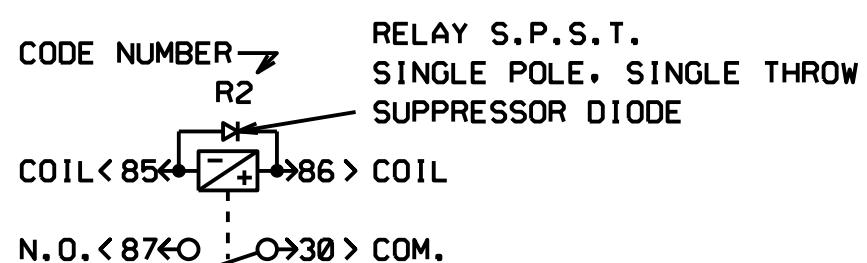
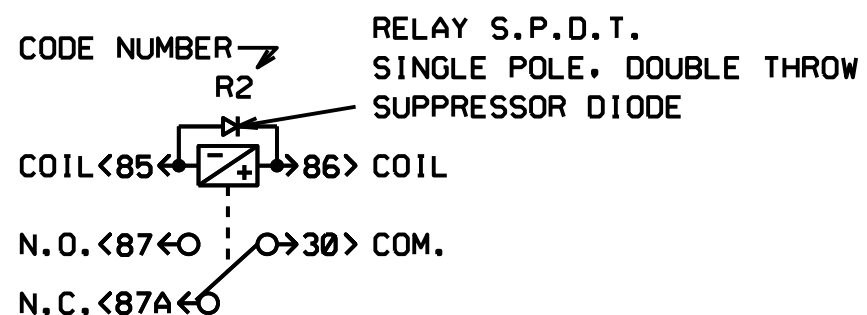
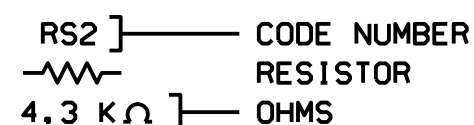
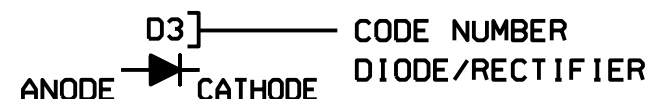
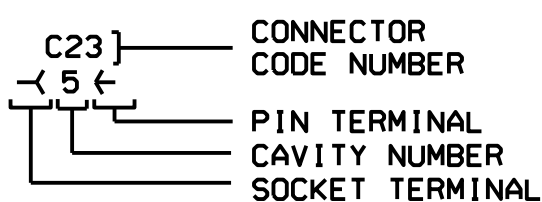
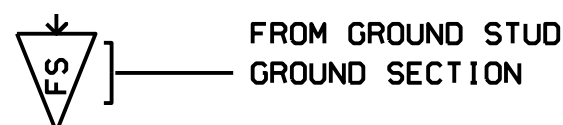
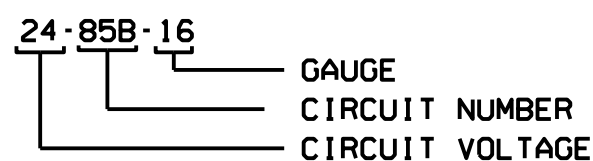

- BLK BLACK
- YEL YELLOW
- RED RED
- WH WHITE
- GRY GREY
- ORA ORANGE
- BLU BLUE
- GRN GREEN
- BRN BROWN
- PUR PURPLE
- PK PINK

# FUSES CODE

No.	PAGE	AMP.	#PREV.	LOCATION	FUNCTION
F 1	6	10A	562407	RR. JCT. BOX	WORLD TRANSMISSION 12V BATTERY
F 2	6	10A	562407	RR. JCT. BOX	WORLD TRANSMISSION 12V IGNITION
F 3	7	20A	562605	FR. JCT. BOX	ELECTRICAL HORNS
F 4	7	5A	562259	FR. JCT. BOX	FIRE ALARM
F 5	8	10A	562407	RR. JCT. BOX	AIR DRYER
F 6	8	5A	562602	FR. JCT. BOX	ETHER COLD START & CRUISE DECEL SW.
F 7	8	5A	562602	FR. JCT. BOX	PARKING BRAKE PRESSURE SW.
F 8	9.2	10A	562407	FR. JCT. BOX	CORNERING LTS
F 9	9.3	15A	562604	RR. JCT. BOX	DOCKING LTS
F 10	9.3	15A	562604	FR. JCT. BOX	FOG LTS
F 11	11.1	5A	562259	FR. JCT. BOX	FRONT SERVICE CPT LTS
F 12	11.2	10A	562407	RR. JCT. BOX	AISLE LTS
F 13	11.2	7.5A	562602	RR. JCT. BOX	EMERGENCY EXIT LTS
F 14	11.3	7.5A	562602	FR. JCT. BOX	DRIVER'S LTS
F 15	11.3	15A	562604	RR. JCT. BOX	READING LTS RH
F 16	11.3	15A	562604	RR. JCT. BOX	READING LTS LH
F 17	11.3	10A	562407	RR. JCT. BOX	INDIRECT LIGHTING R.H.
F 18	11.4	10A	562407	RR. JCT. BOX	24V FLUORESCENT RH
F 19	11.4	10A	562407	RR. JCT. BOX	24V FLUORESCENT LH
F 20	11.3	3A	562599	FR. JCT. BOX	GENERAL & READING LTS. SW.
F 21	12	10A	560061	RR. JCT. BOX	PRIME PUMP
F 22	14	10A	562407	FR. JCT. BOX	POWER 12V OUTLET
F 23	14	15A	562604	FR. JCT. BOX	DRIVER'S WINDOW LIFTER
F 24	14	15A	562604	FR. JCT. BOX	CIGAR LIGHTER
F 25	14	3A	562599	FR. JCT. BOX	SUN VISOR
F 26	15	5A	562259	FR. JCT. BOX	WATER HTR TIMER
F 27	23	5A	562259	RR. JCT. BOX	GALLEY LAMP & LAVATORY NIGHT LTS.
F 28	17	10A	562407	RR. JCT. BOX	LAVATORY PUMP
F 29	17	7.5A	562602	RR. JCT. BOX	LAVATORY LTS
F 31	17	5A	562259	FR. JCT. BOX	FRONT DESTINATION SIGN ELECTRONIC
F 31	17	7.5A	562602	FR. JCT. BOX	FRONT DESTINATION SIGN ELECTRIC
F 32	11.3	5A	562259	FR. JCT. BOX	PASSENGER NO SMOKING LTS
F 33	18	5A	562259	FR. JCT. BOX	KNEELING SYSTEM
F 34	19	3A	562599	FR. JCT. BOX	LUGGAGE DOOR LOCK
F 39	22	10A	562407	FR. JCT. BOX	UPPER WINDSHIELD FAN DEFROST
F 40	22	20A	562605	FR. JCT. BOX	HEATED WINDSCHIELD LH
F 41	22	20A	562605	FR. JCT. BOX	HEATED WINDSCHIELD RH
F 46	24	7.5A	562602	FR. JCT. BOX	MIRROR ADJUST & HEATED 24V SPARTAN
F 47	24	7.5A	562407	FR. JCT. BOX	MIRROR ADJUST & HEATED 12V RAMCO
F 48	25	10A	562407	RR. JCT. BOX	WHEEL CHAIR LIFT POWER CONTROL
F 49	26	20A	562605	RR. JCT. BOX	PRE-HEAT WATER HEATER WEBASTO
F 50	26	20A	562605	RR. JCT. BOX	PRE-HEAT WATER HEATER
F 51	11.2	7.5A	562602	RR. JCT. BOX	HAR RACK CPT LTS
F 57	17	5A	562259	RR. JCT. BOX	LAVATORY FLUORESCENT
F 58	11.3	10A	562407	RR. JCT. BOX	INDIRECT LIGHTING L.H.
F 59	17.1	3A	562599	RR. JCT. BOX	GENERATOR RUN RLY.
F 60	17.1	10A	562407	RR. JCT. BOX	LAVATORY FAN
F 61	27	1A	560893	FR. JCT. BOX	INTERCOM
F 70	23	7.5A	562602	GALLEY PANEL	GALLEY RH CONTAINER
F 71	23	7.5A	562602	GALLEY PANEL	GALLEY LH CONTAINER
F 72	23	10A	562407	GALLEY PANEL	GALLEY REFRIGERATOR COMPRESSOR
F 73	23	35A	562608	GALLEY PANEL	GALLEY COFFEMAKER
F 74	23	7.5	560598	BAT. CPT.	GALLEY REFRIGERATOR

# FUSES CODE

No.	PAGE	AMP.	#PREV.	LOCATION	FUNCTION
F 1	6.1	10A	562407	RR. JCT. BOX	WORLD TRANSMISSION 12V BATTERY
F 2	6.1	10A	562407	RR. JCT. BOX	WORLD TRANS.& EATON TRANS.12V IGNITION
F 3	7.2	20A	562605	FR. JCT. BOX	ELECTRICAL HORNS
F 4	7.2	5A	562259	FR. JCT. BOX	FIRE ALARM
F 5	8.1	10A	562407	RR. JCT. BOX	AIR DRYER
F 6	5.1	5A	562602	FR. JCT. BOX	CRUISE DECEL SW.
F 7	8.1	5A	562602	FR. JCT. BOX	PARKING BRAKE PRESSURE SW.
F 8	9.2	10A	562407	FR. JCT. BOX	CORNERING LTS
F 9	9.3	15A	562604	RR. JCT. BOX	DOCKING LTS
F 10	9.3	15A	562604	FR. JCT. BOX	FOG LTS
F 11	11.1	5A	562259	FR. JCT. BOX	FRONT SERVICE CPT LTS
F 12	11.2	10A	562407	RR. JCT. BOX	AISLE LTS
F 13	11.2	7.5A	562602	RR. JCT. BOX	EMERGENCY EXIT LTS
F 14	11.3	15A	562602	FR. JCT. BOX	DRIVER'S LTS
F 15	11.3	15A	562604	RR. JCT. BOX	READING LTS RH
F 16	11.3	15A	562604	RR. JCT. BOX	READING LTS LH
F 17	11.3	10A	562407	RR. JCT. BOX	INDIRECT LIGHTING R.H.
F 18	11.4	10A	562407	RR. JCT. BOX	24V FLUORESCENT RH
F 19	11.4	10A	562407	RR. JCT. BOX	24V FLUORESCENT LH
F 20	11.3	5A	562599	FR. JCT. BOX	GENERAL & READING LTS. SW.
F 21	12.1	10A	560061	RR. JCT. BOX	PRIME PUMP
F 22	14.1	10A	562407	FR. JCT. BOX	POWER 12V OUTLET
F 23	14.1	15A	562604	FR. JCT. BOX	DRIVER'S WINDOW LIFTER
F 24	14.1	15A	562604	FR. JCT. BOX	CIGAR LIGHTER
F 25	14.1	3A	562599	FR. JCT. BOX	SUN VISOR
F 26	26.1	5A	562259	FR. JCT. BOX	WATER HTR TIMER
F 27	17.1	5A	562259	RR. JCT. BOX	GALLEY LAMP & LAVATORY NIGHT LTS.
F 28	17.1	10A	562407	RR. JCT. BOX	LAVATORY PUMP
F 29	17.1	7.5A	562602	RR. JCT. BOX	LAVATORY LTS
F 31	17.1	5A	562259	FR. JCT. BOX	FRONT DESTINATION SIGN ELECTRONIC
F 31	17.1	7.5A	562602	FR. JCT. BOX	FRONT DESTINATION SIGN ELECTRIC
F 32	11.3	5A	562259	FR. JCT. BOX	PASSENGER NO SMOKING LTS
F 33	18.1	5A	562259	FR. JCT. BOX	KNEELING SYSTEM
F 34	19.1	3A	562599	FR. JCT. BOX	LUGGAGE DOOR LOCK
F 39	22.1	10A	562407	FR. JCT. BOX	UPPER WINDSHIELD FAN DEFROST
F 40	22.1	20A	562605	FR. JCT. BOX	HEATED WINDSHIELD LH
F 41	22.1	20A	562605	FR. JCT. BOX	HEATED WINDSHIELD RH
F 46	24.1	7.5A	562602	FR. JCT. BOX	MIRROR ADJUST & HEATED 24V SPARTAN
F 47	24.3	7.5A	562407	FR. JCT. BOX	MIRROR ADJUST & HEATED 12V RAMCO
F 48	25.2	10A	562407	RR. JCT. BOX	WHEEL CHAIR LIFT POWER CONTROL
F 49	26.1	20A	562605	RR. JCT. BOX	PRE-HEAT WATER HEATER WEBASTO
F 50	26.1	20A	562605	RR. JCT. BOX	PRE-HEAT WATER HEATER
F 51	11.2	7.5A	562602	RR. JCT. BOX	HAR RACK CPT LTS
F 57	17.1	5A	562259	RR. JCT. BOX	LAVATORY FLUORESCENT
F 58	11.3	10A	562407	RR. JCT. BOX	INDIRECT LIGHTING L.H.
F 59	4.1	3A	562599	RR. JCT. BOX	GENERATOR RUN RLY.
F 60	17.1	10A	562407	RR. JCT. BOX	LAVATORY FAN
F 61	27.1	1A	560893	FR. JCT. BOX	INTERCOM
F 62	2.1	3A	562599	RR. JCT. BOX	PRO-LINK & FIRE ALARM
F 63	27.1	3A	560893	MON. CLARION	BACK-UP MONITOR CLARION
F 70	23.1	7.5A	562602	GALLEY PANEL	GALLEY RH CONTAINER
F 71	23.1	7.5A	562602	GALLEY PANEL	GALLEY LH CONTAINER
F 72	23.1	10A	562407	GALLEY PANEL	GALLEY REFRIGERATOR COMPRESSOR
F 73	23.1	35A	562608	GALLEY PANEL	GALLEY COFFEMAKER
F 74	23.1	7.5	560598	BAT. CPT.	GALLEY REFRIGERATOR

# LOGIC GATE

## TRUTH TABLE

AND GATE		
INPUT		OUT
A	B	C
0	0	0
0	1	0
1	0	0
1	1	1

• OUTPUT IS 1 WHEN ALL INPUT IS 1

NAND GATE		
INPUT		OUT
A	B	C
0	0	1
0	1	1
1	0	1
1	1	0

• OUTPUT IS 0 WHEN ALL INPUT IS 0

OR GATE		
INPUT		OUT
A	B	C
0	0	0
0	1	1
1	0	1
1	1	1

• OUTPUT IS 1 WHEN EITHER INPUT IS 1

NOR GATE		
INPUT		OUT
A	B	C
0	0	1
0	1	0
1	0	0
1	1	0

• OUTPUT IS 1 WHEN NONE INPUT IS 1

NOT GATE		
INPUT	OUT	
A	B	
0	1	
1	0	

• OUTPUT IS REVERSE OF INPUT

ON-DELAY	
XX SECOND AFTER A=1 THAN B=1	

OFF-DELAY	
XX SECOND AFTER A=0 THAN B=0	

POSITIVE INPUT	
INPUT CONNECTED WITH SIGNAL 12 VOLTS OR 24 VOLTS WHEN ACTIVATING	

SINKING INPUT	
INPUT CONNECTED WITH SIGNAL GROUND WHEN ACTIVATING	

INPUT OR OUTPUT LEVEL

LEVEL 1 = 12 VOLTS OR 24 VOLTS

LEVEL 0 = 0 VOLT ( TO GROUND )

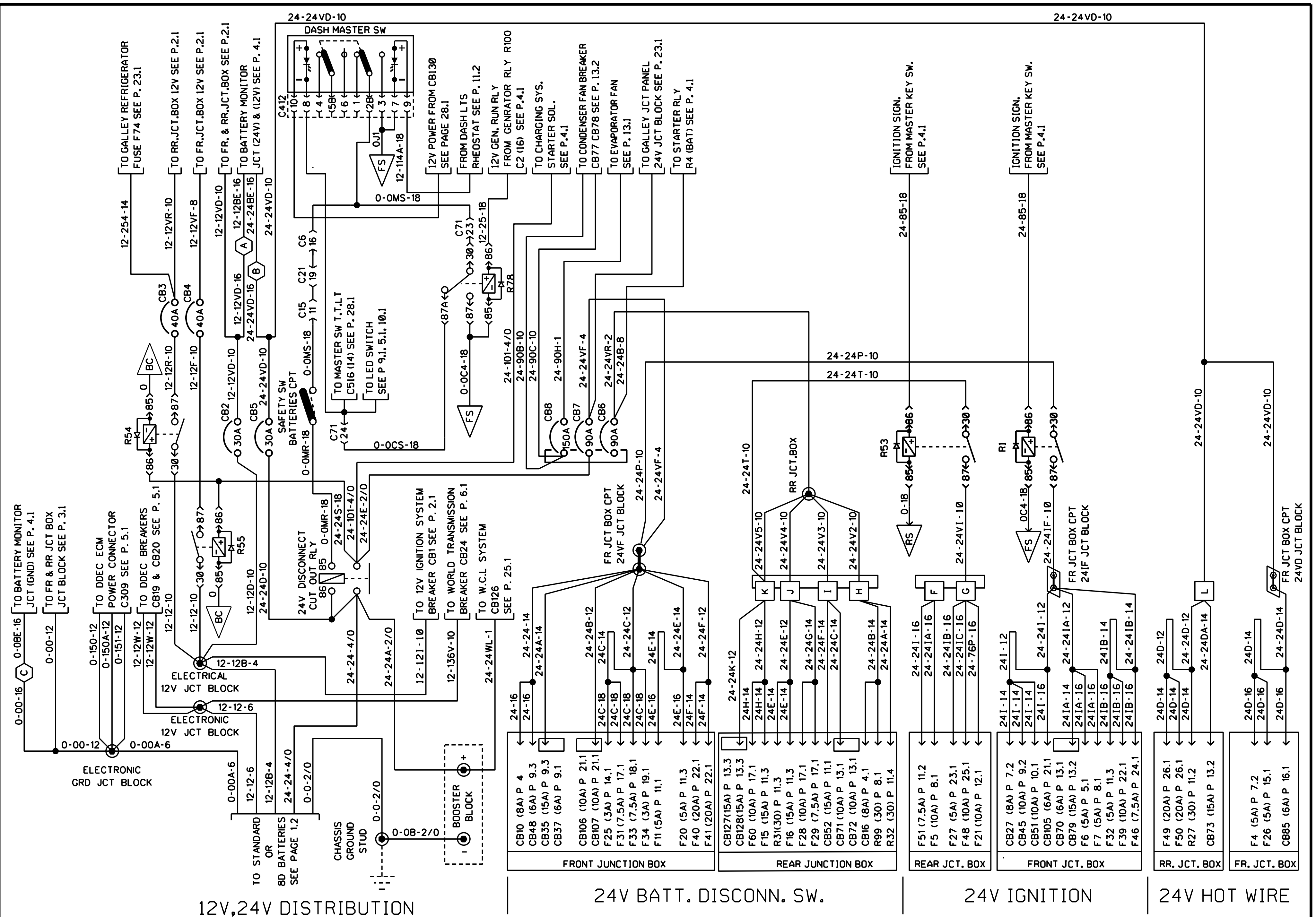



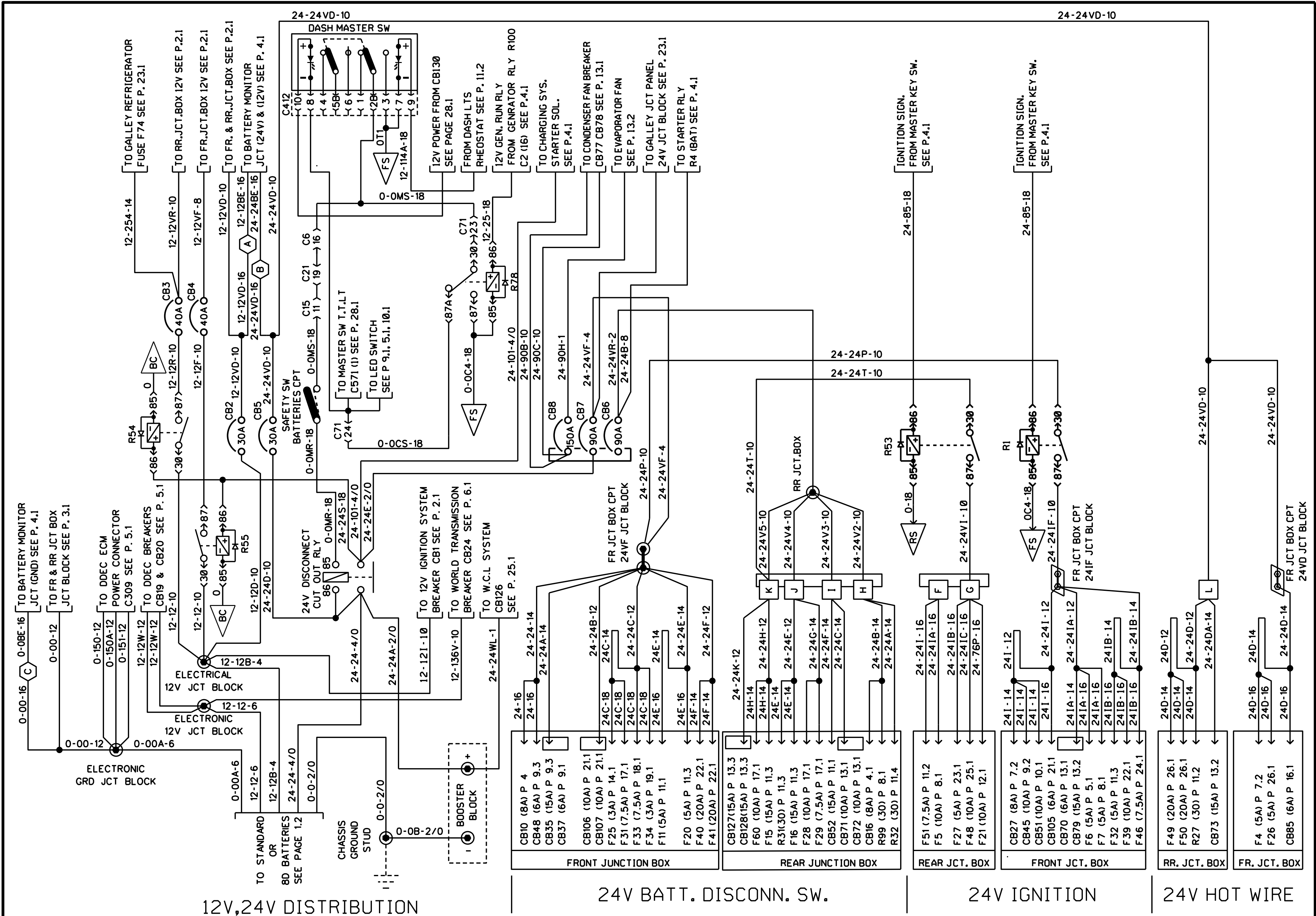

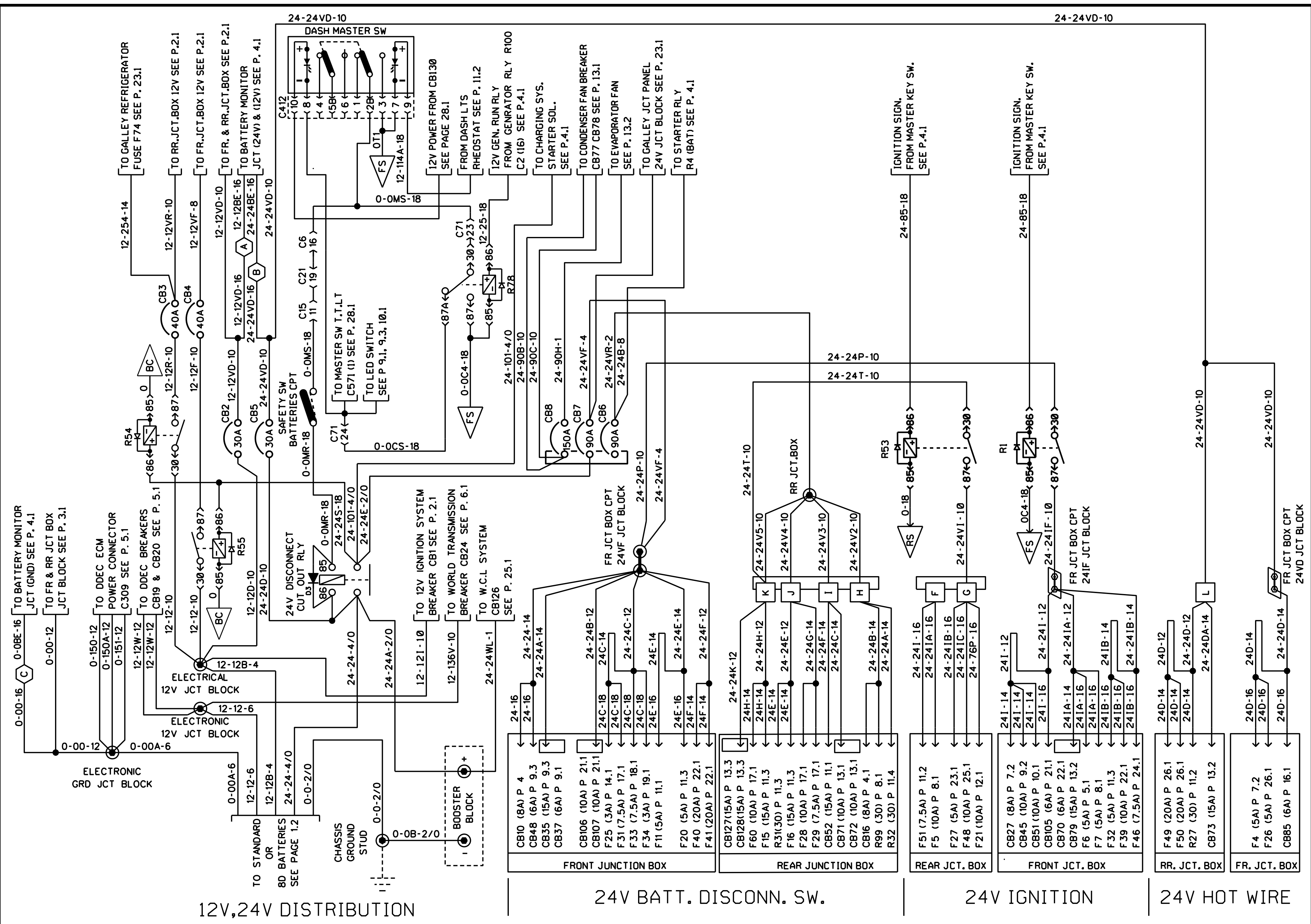

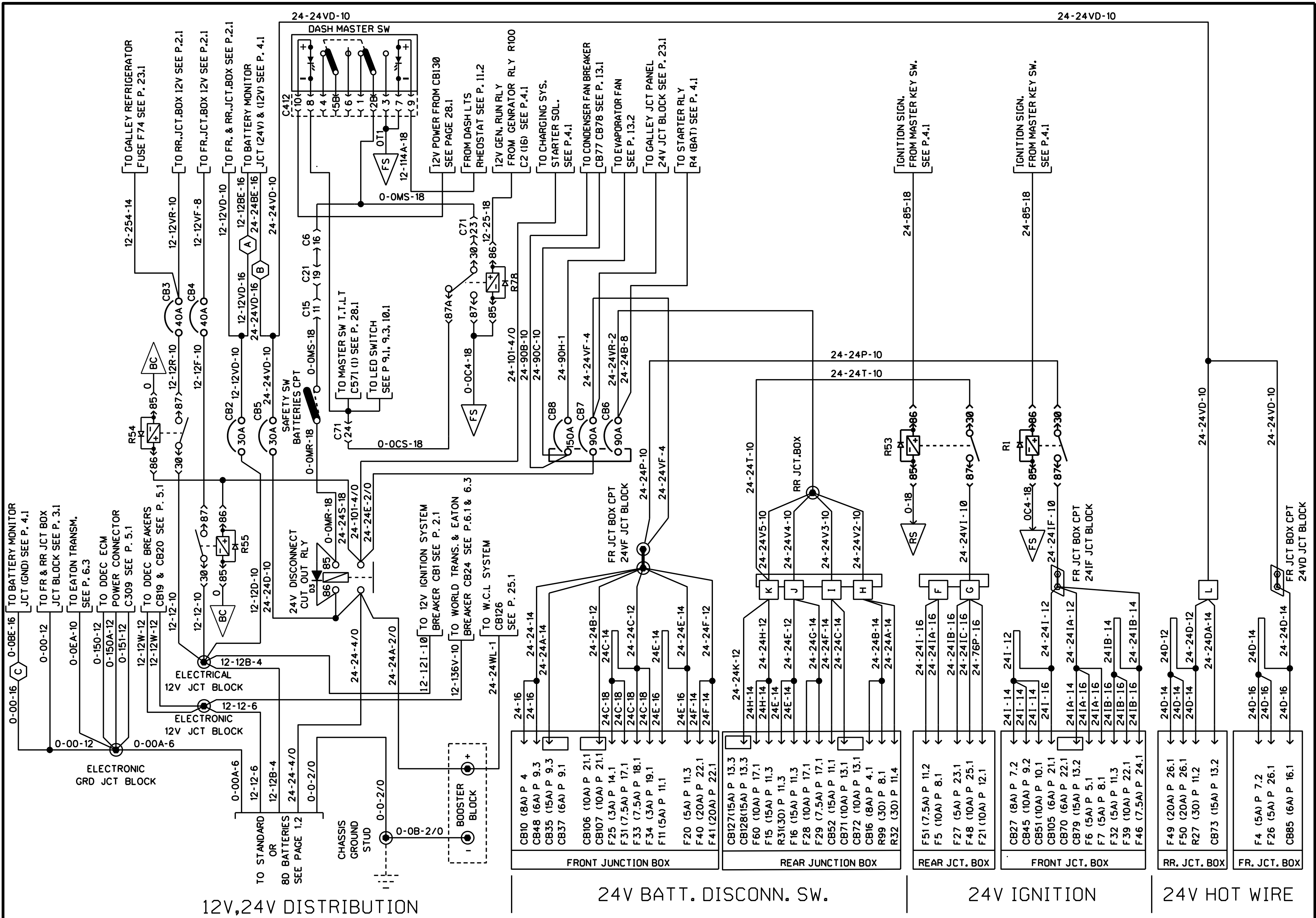

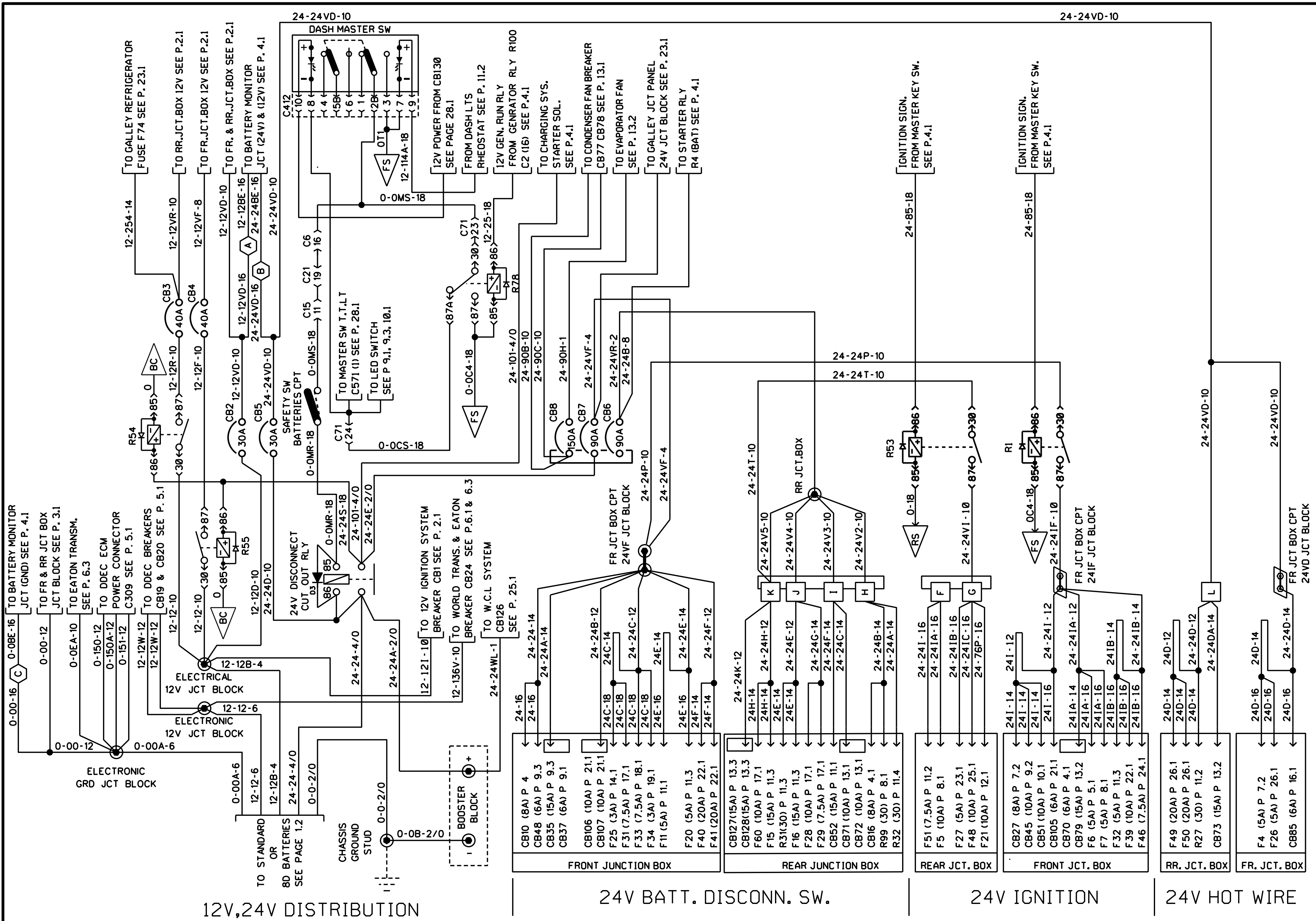

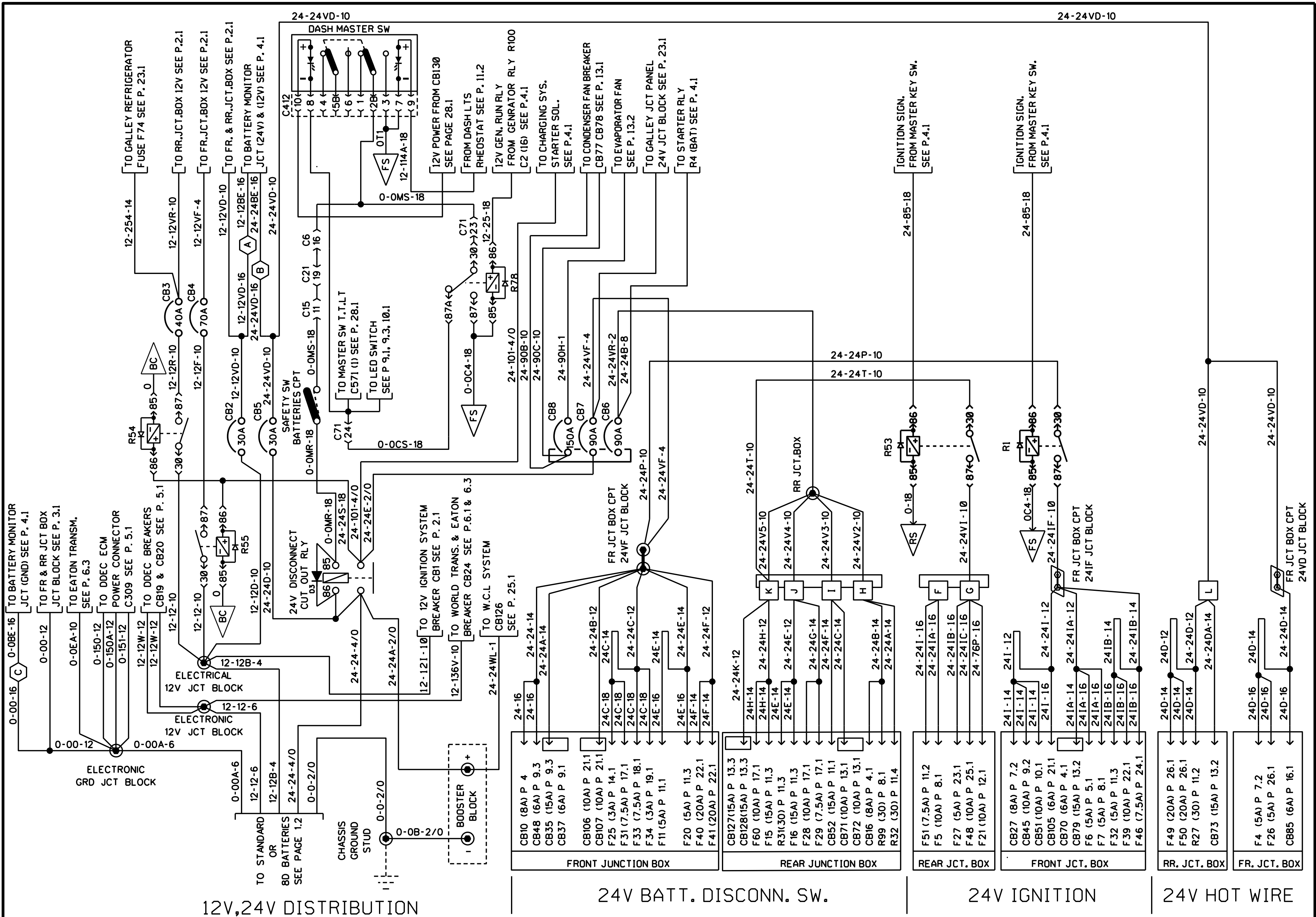

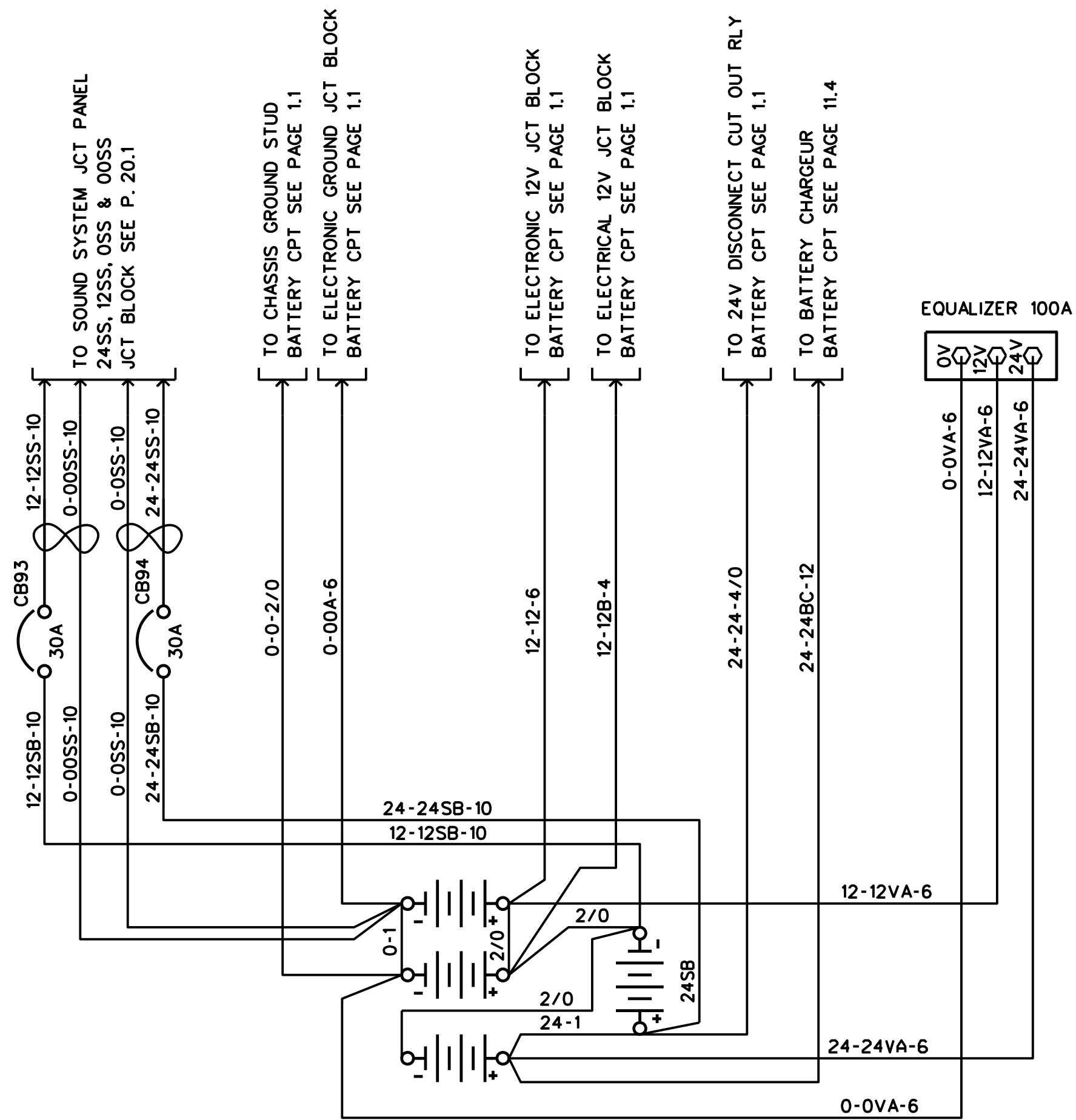

STANDARD BATTERIES

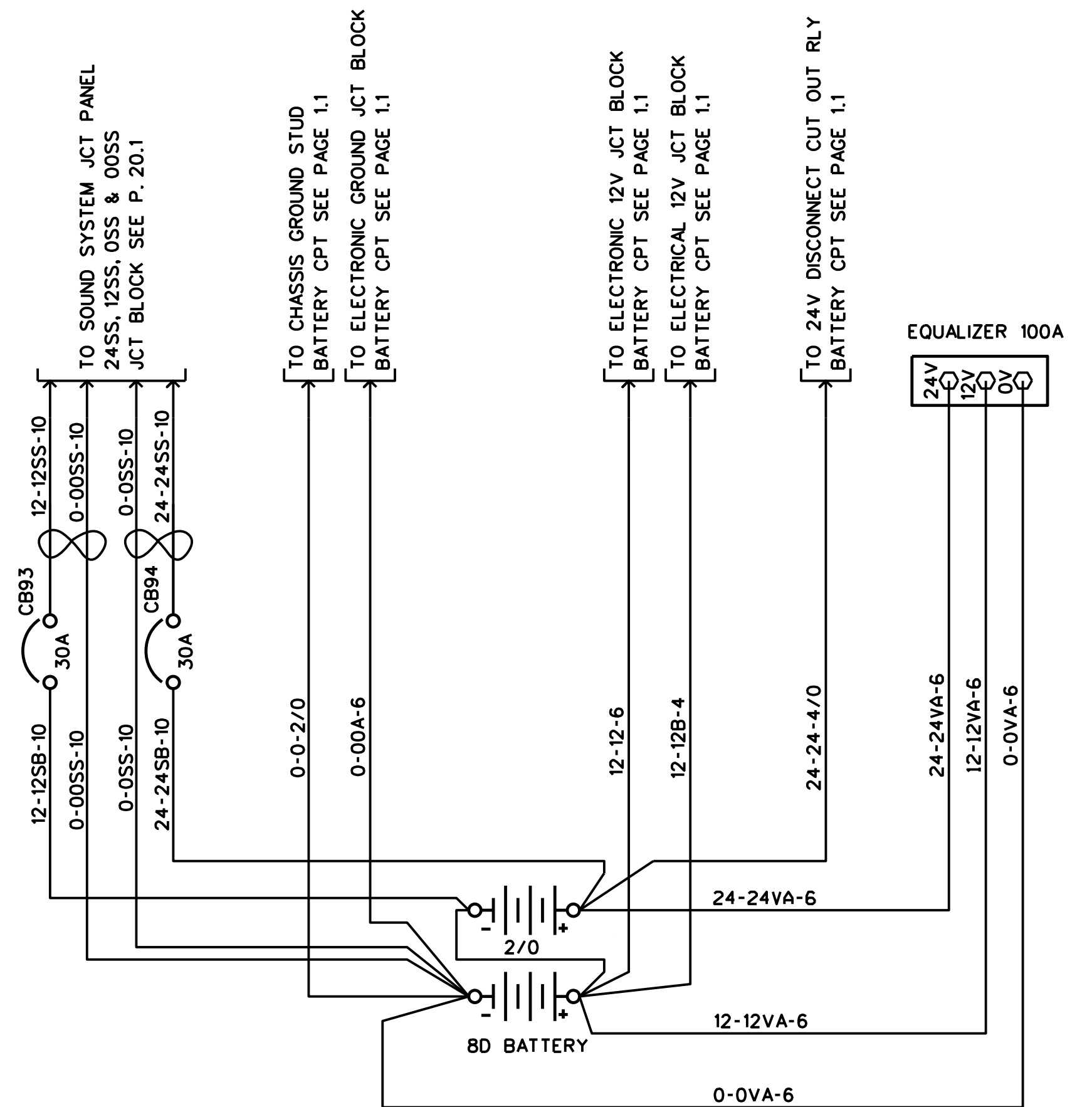

8D BATTERIES



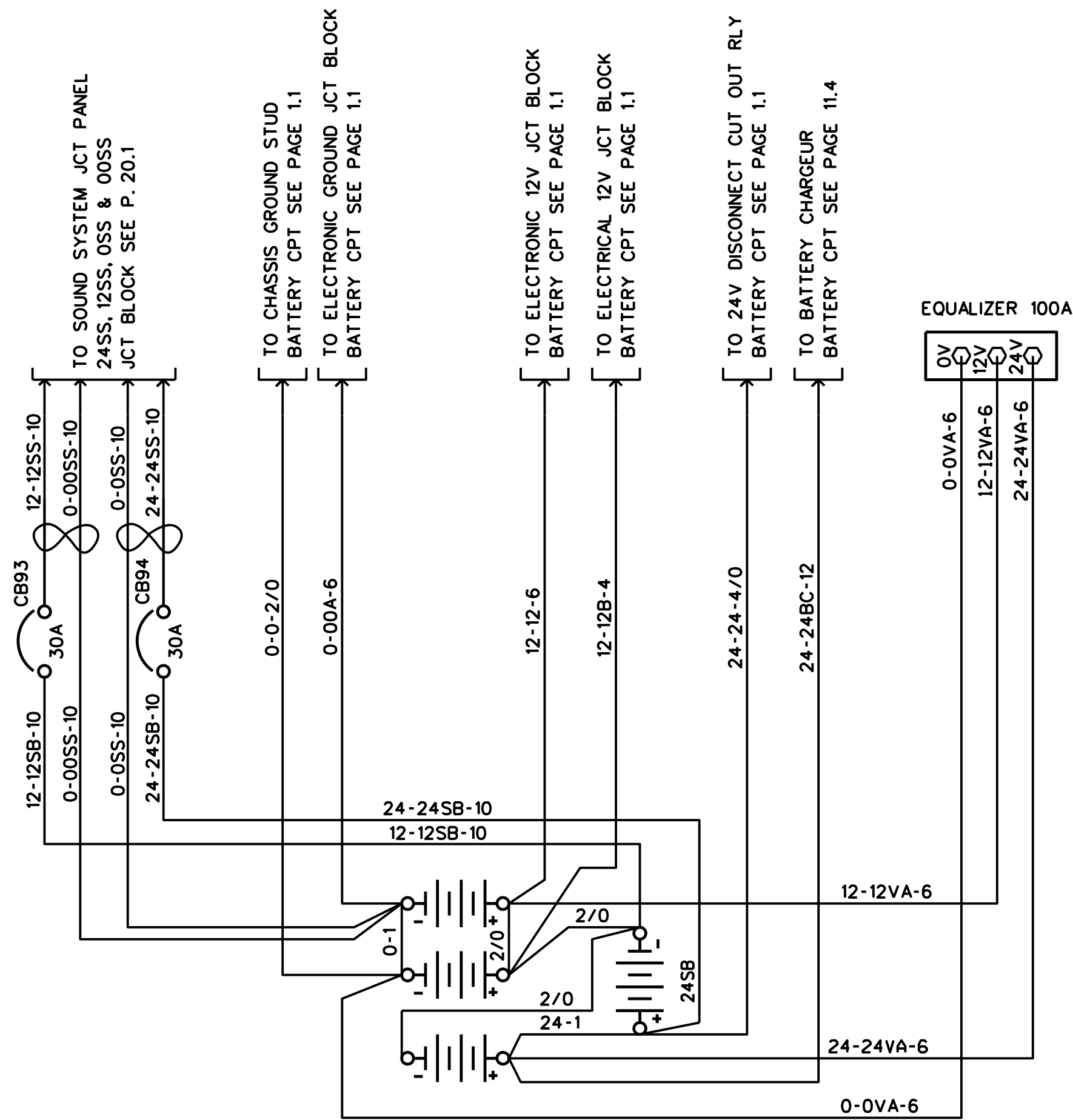

STANDARD BATTERIES

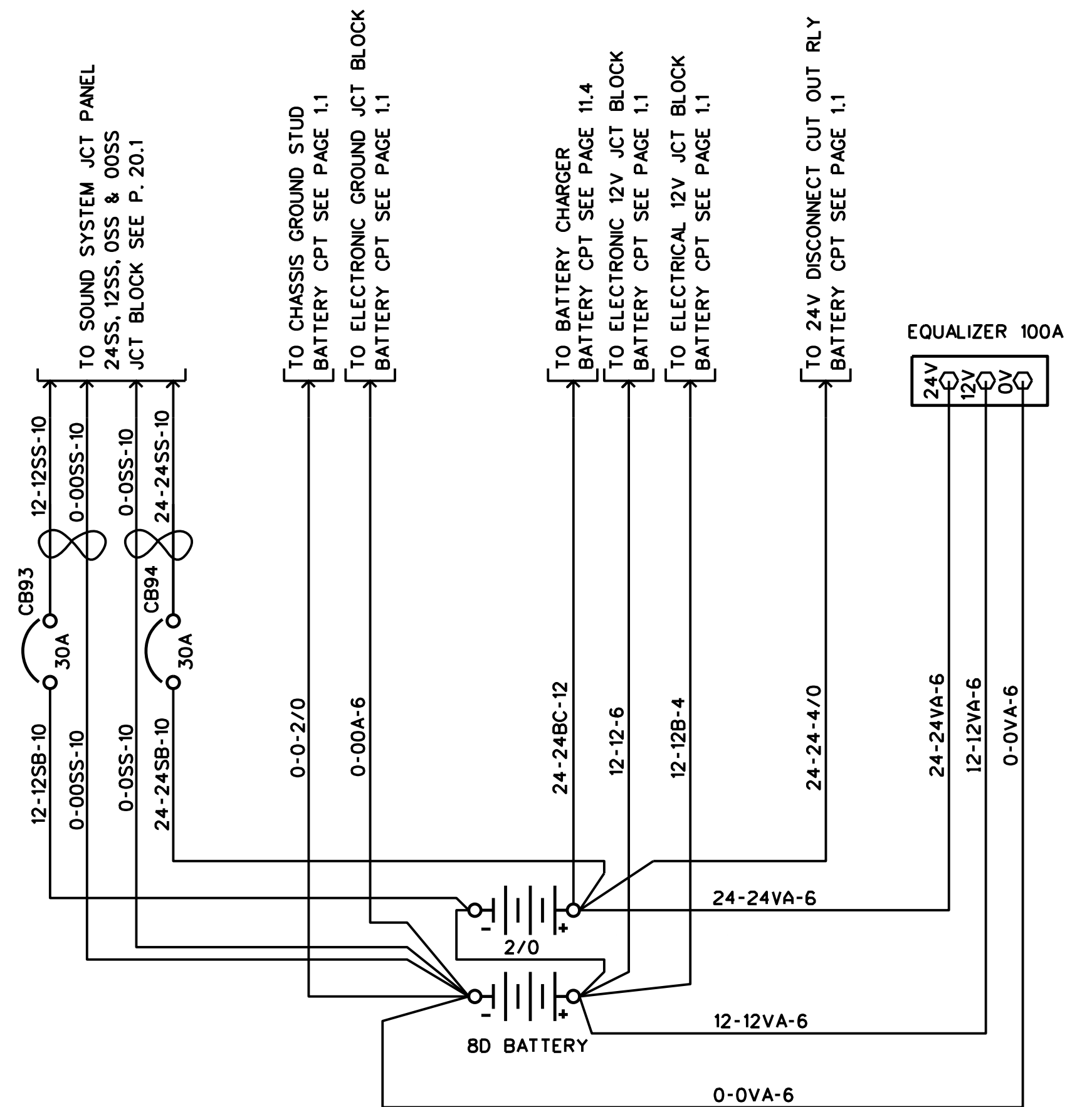

8D BATTERIES

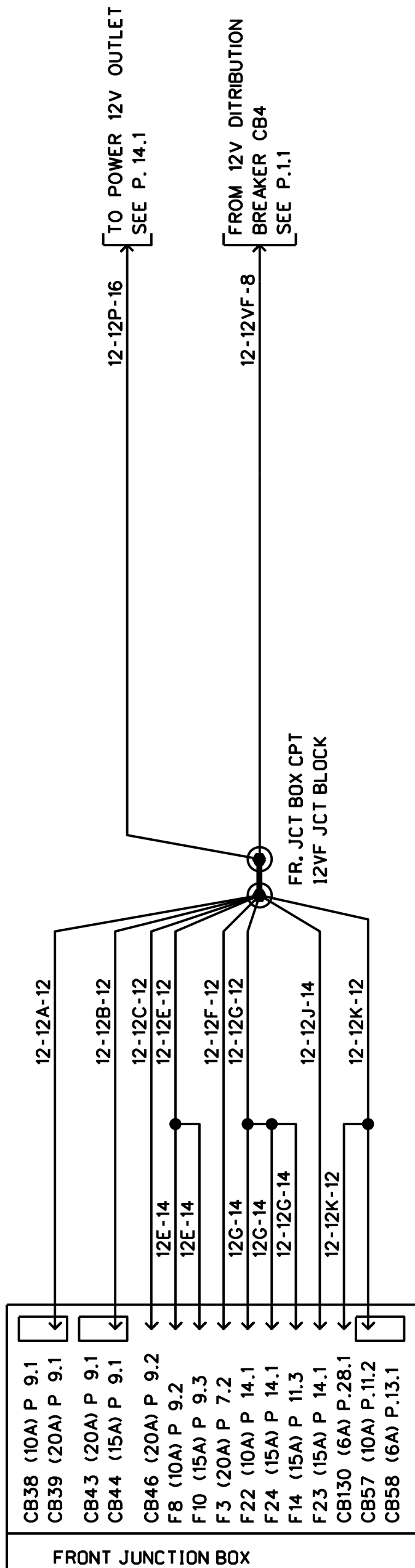

12V BATT. DISCONN. SW.

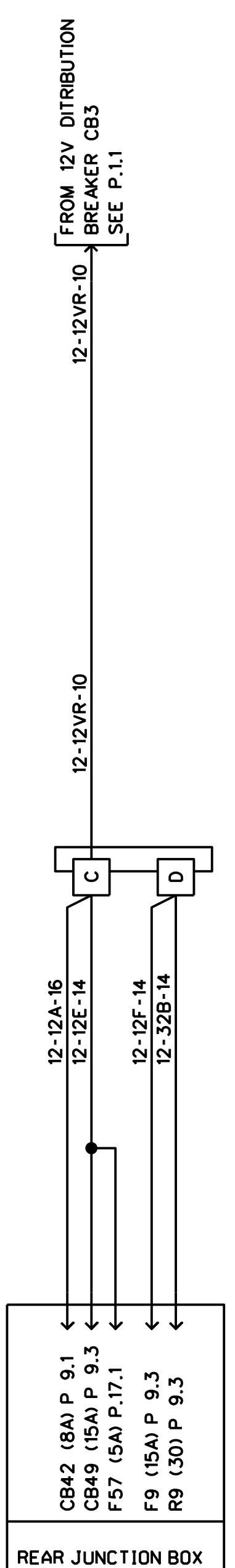

12V IGNITION

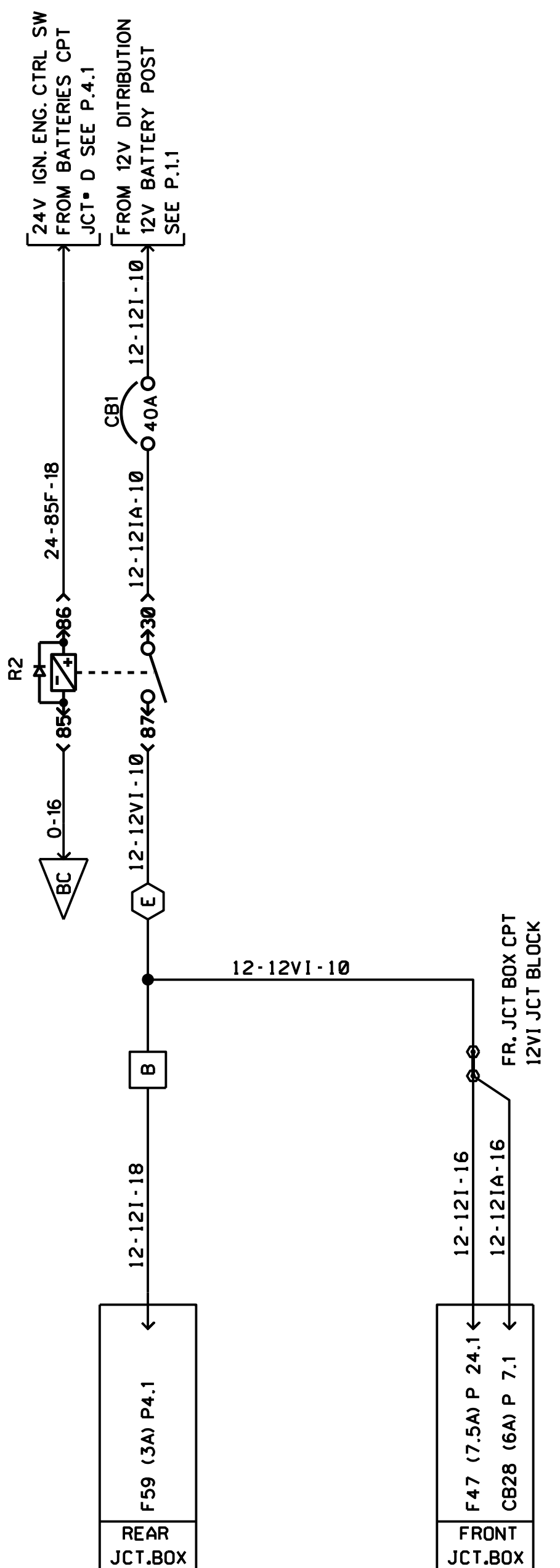

12V HOT WIRE

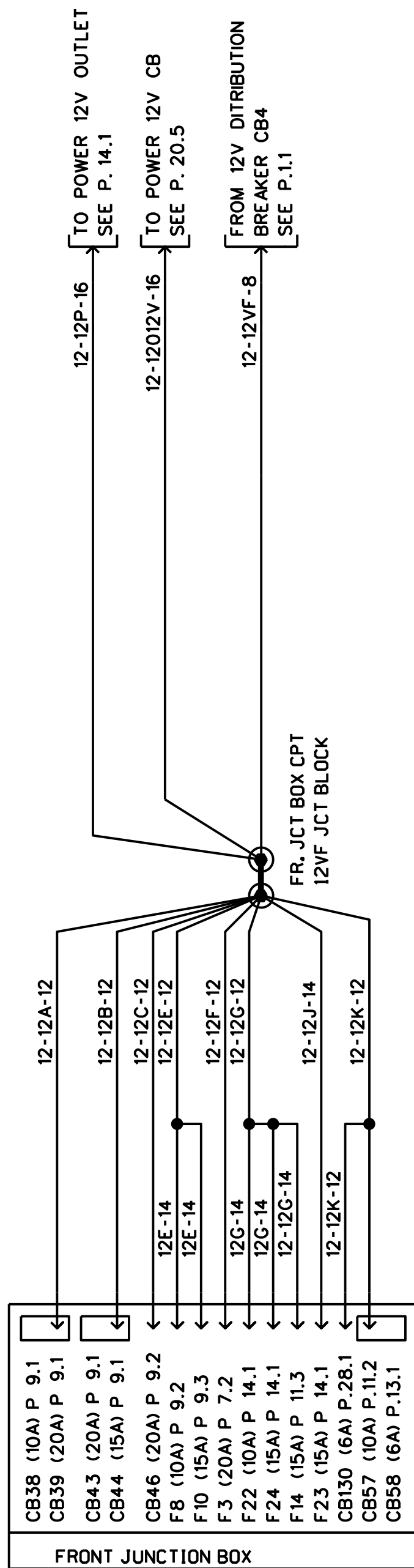

12V BATT. DISCONN. SW.

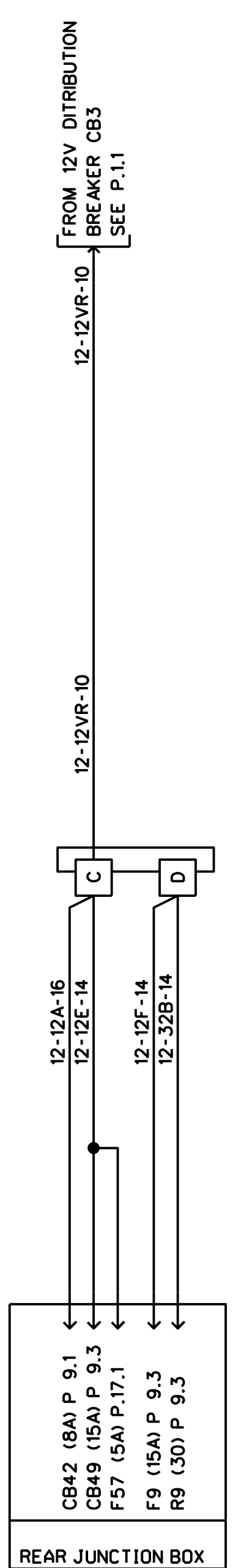

12V IGNITION

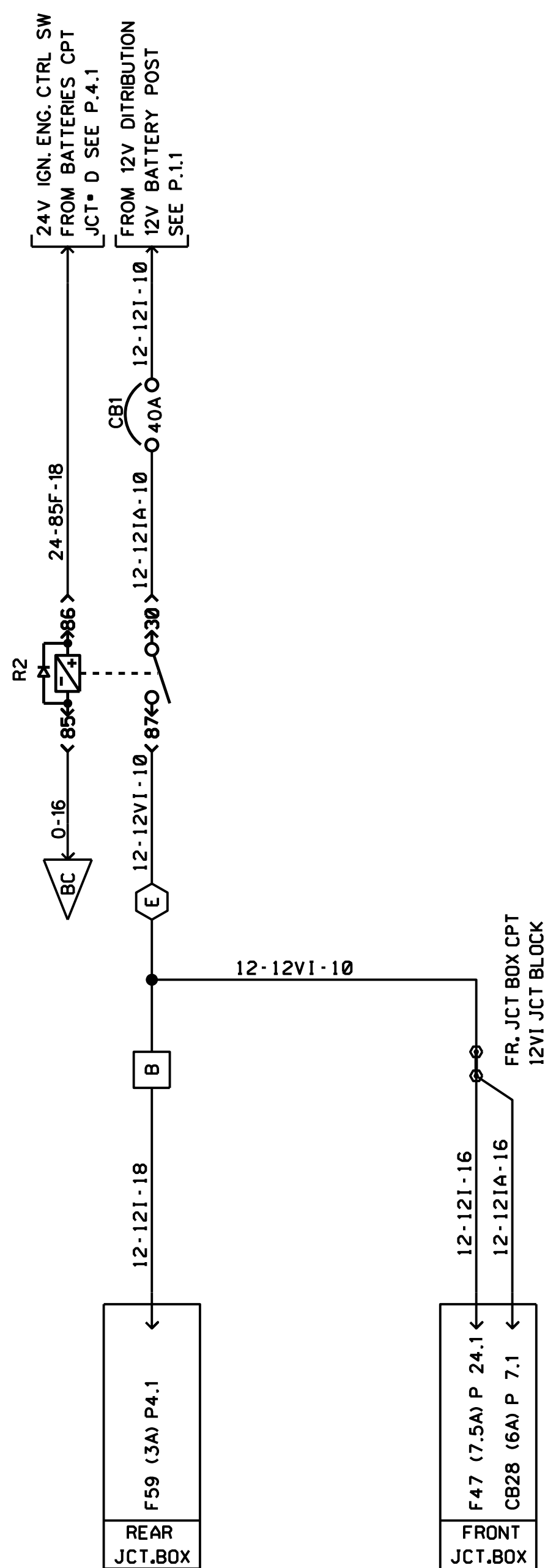

12V HOT WIRE

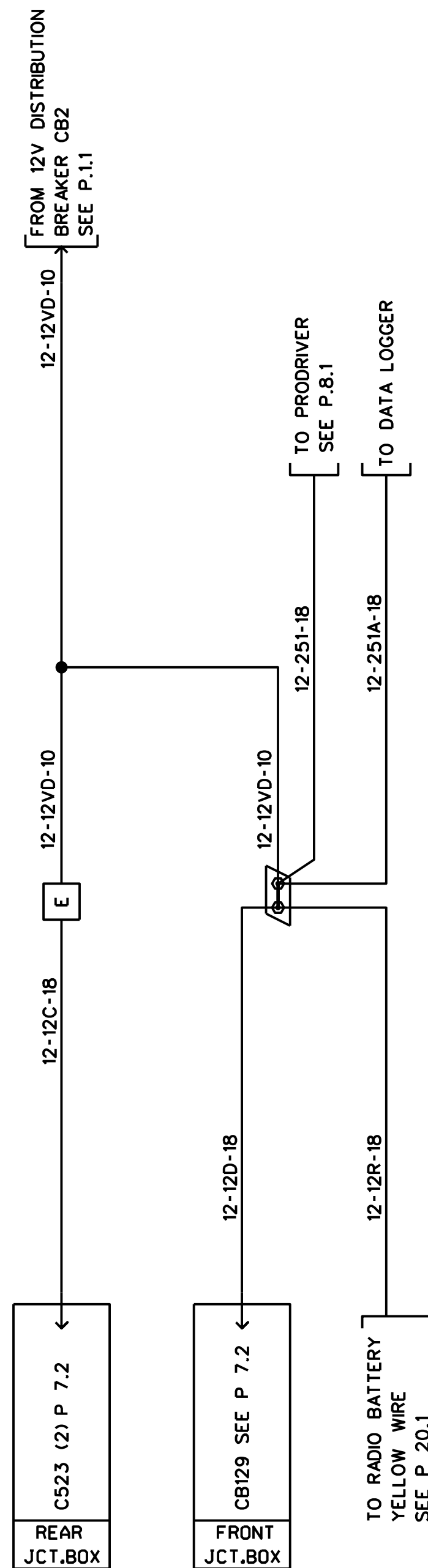

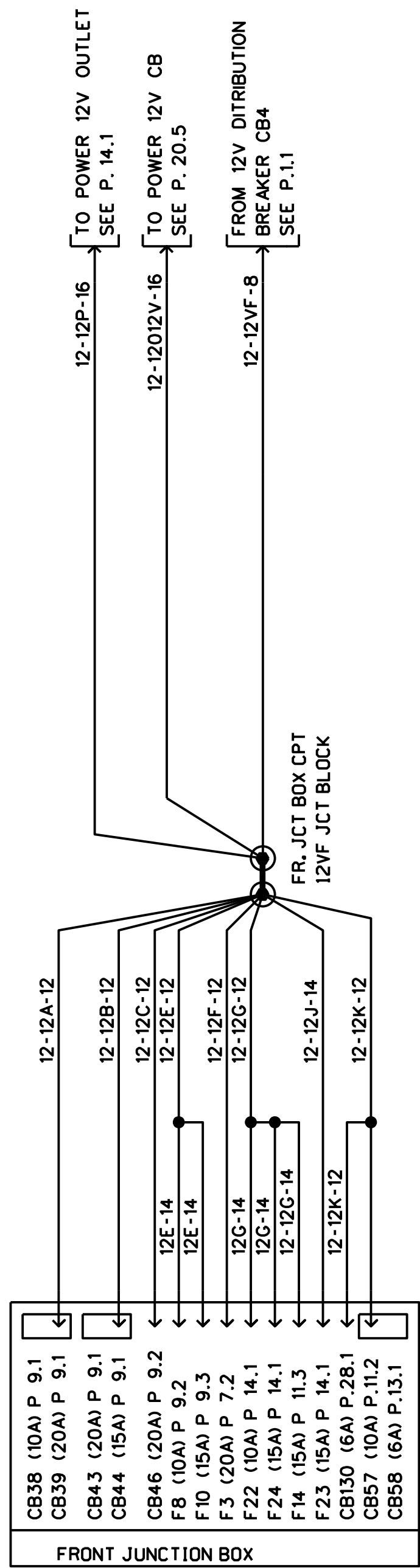

12V BATT. DISCONN. SW.

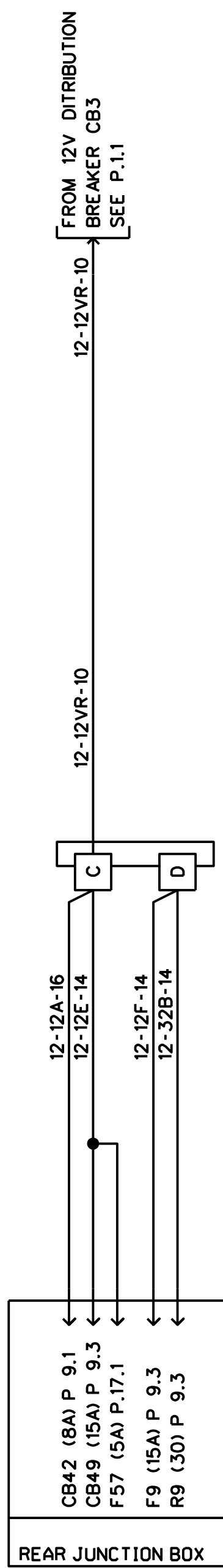

12V IGNITION

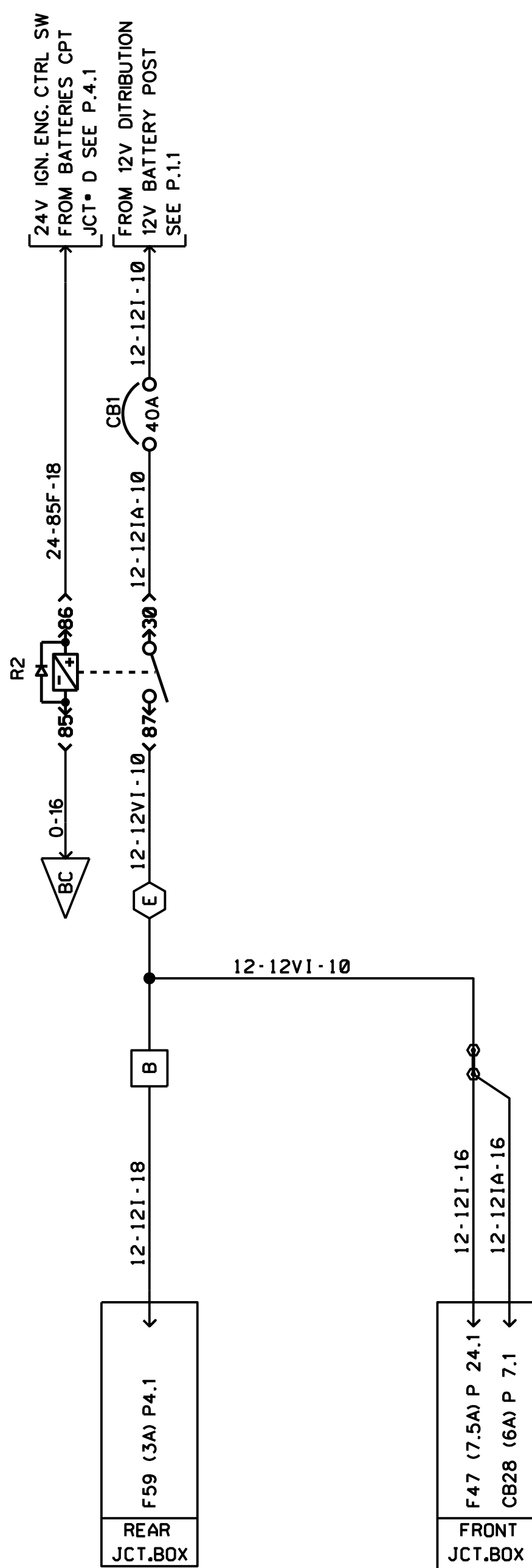

12V HOT WIRE

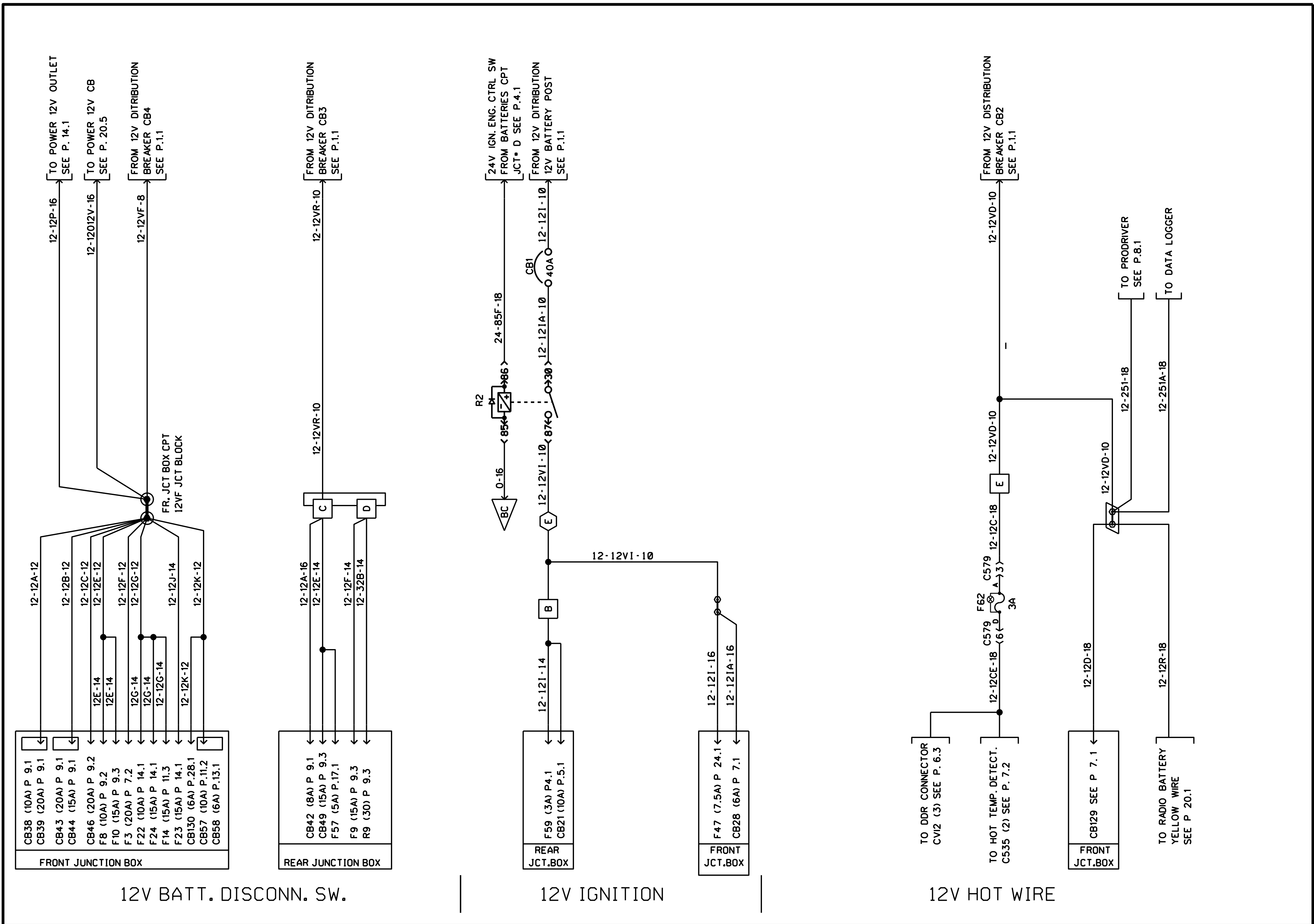

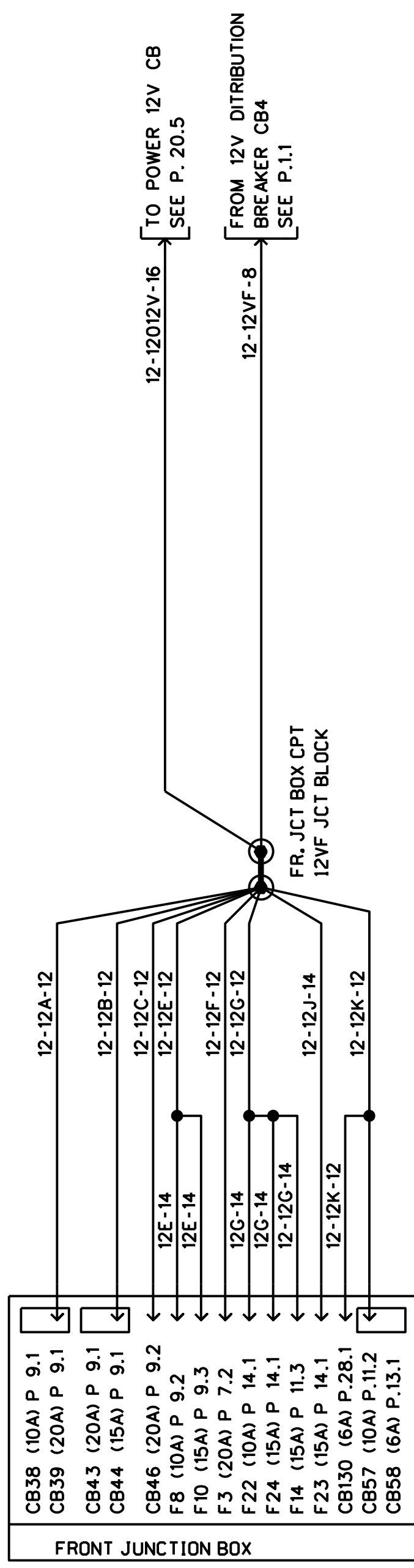

12V BATT. DISCONN. SW.

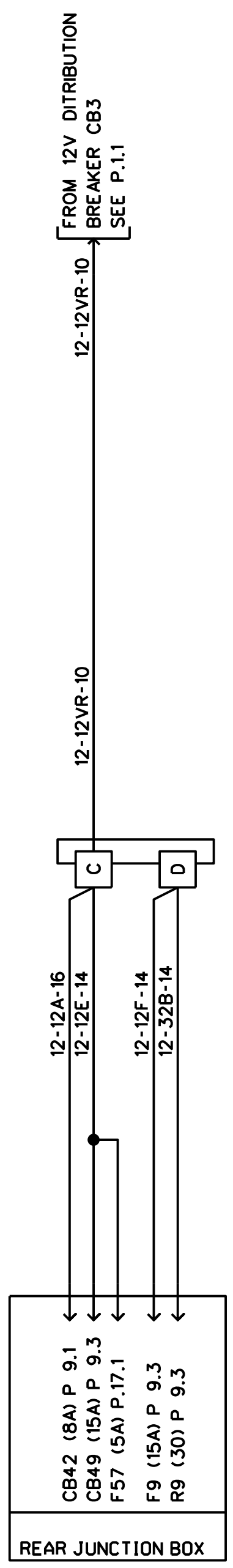

12V IGNITION

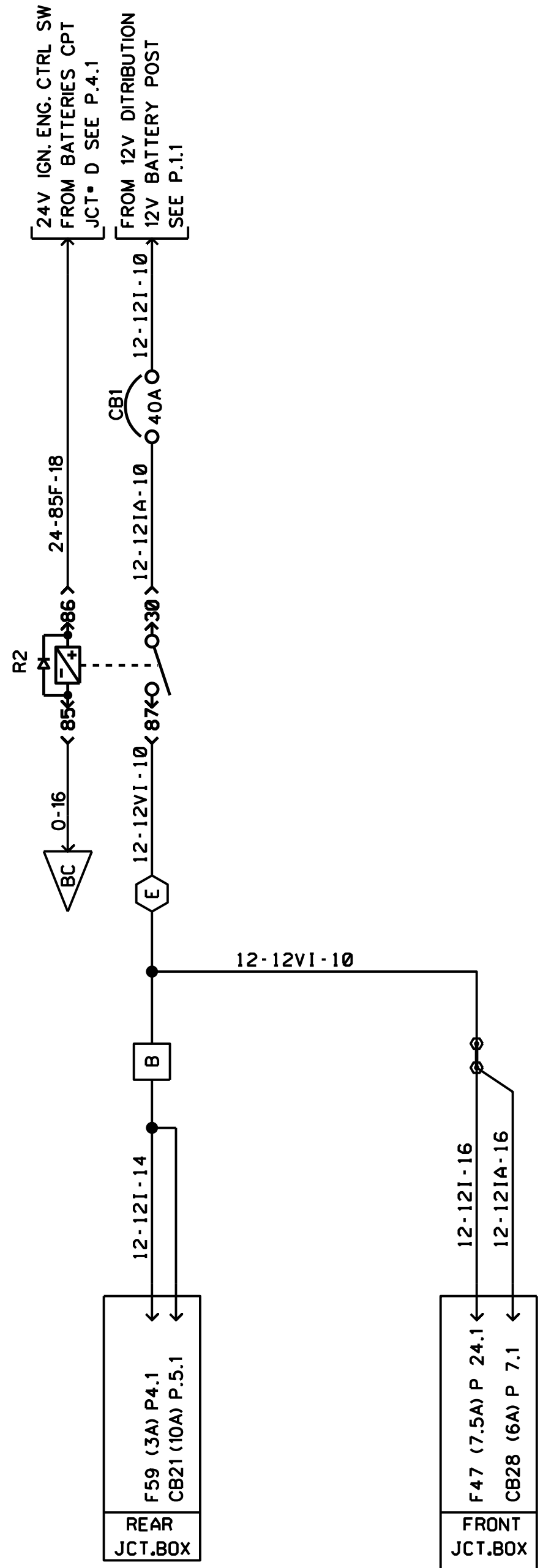

12V HOT WIRE

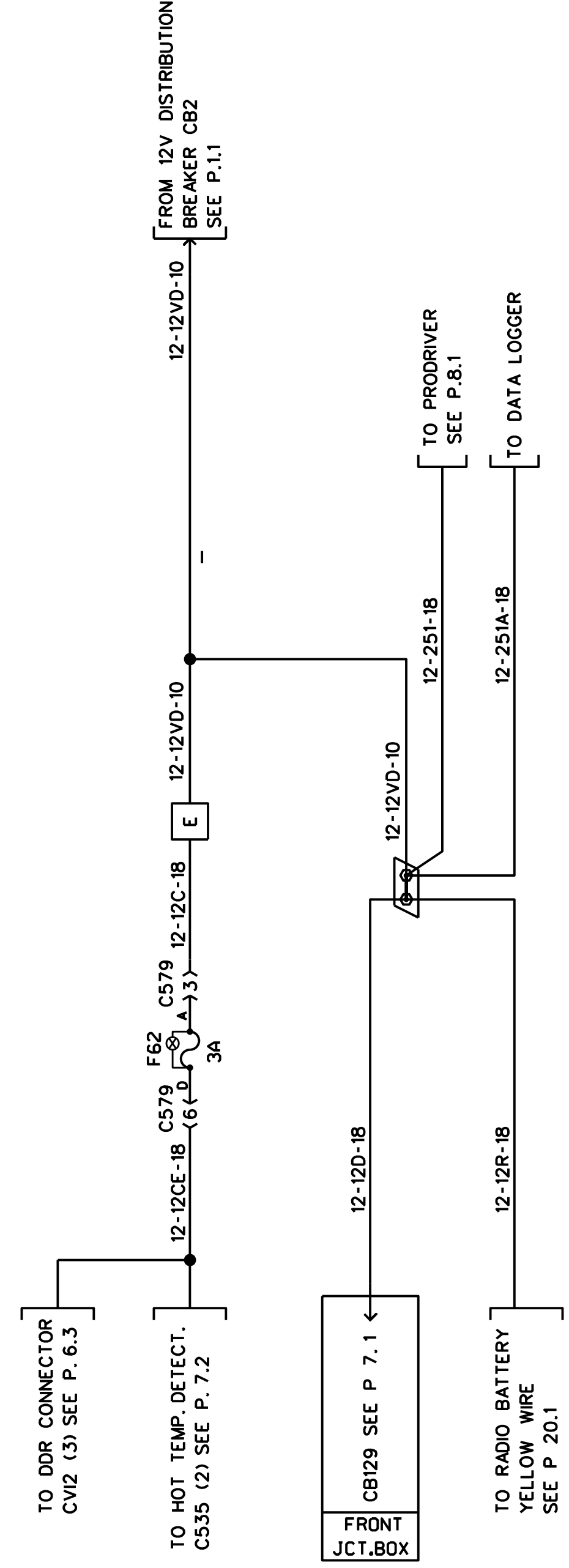



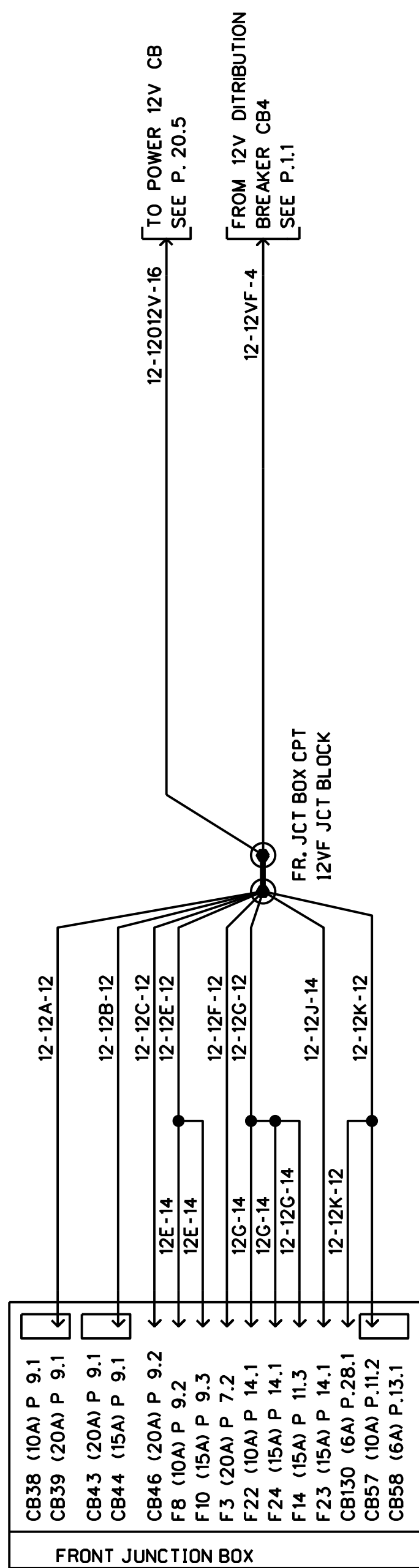

12V BATT. DISCONN. SW.

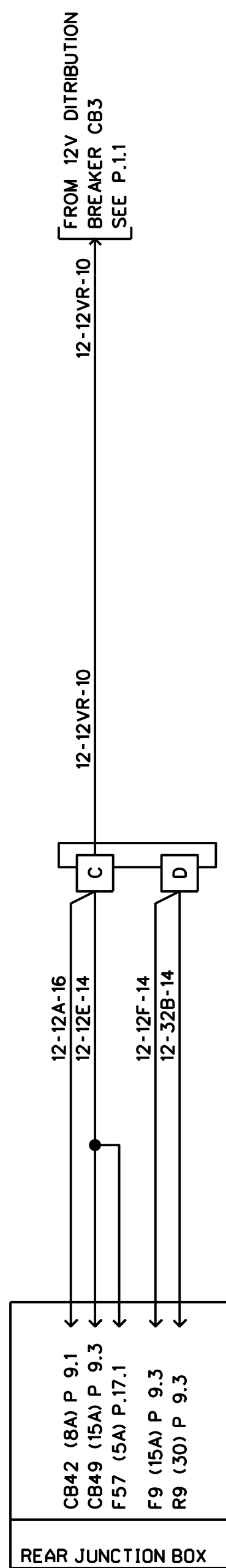

12V IGNITION

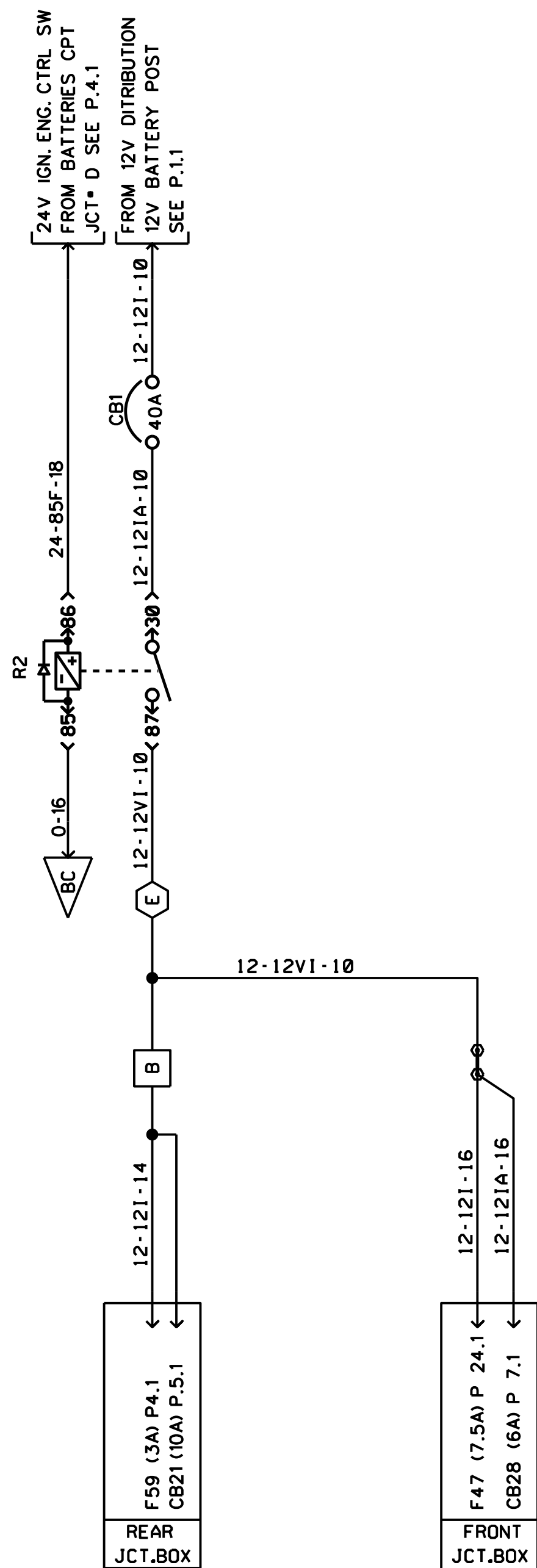

12V HOT WIRE

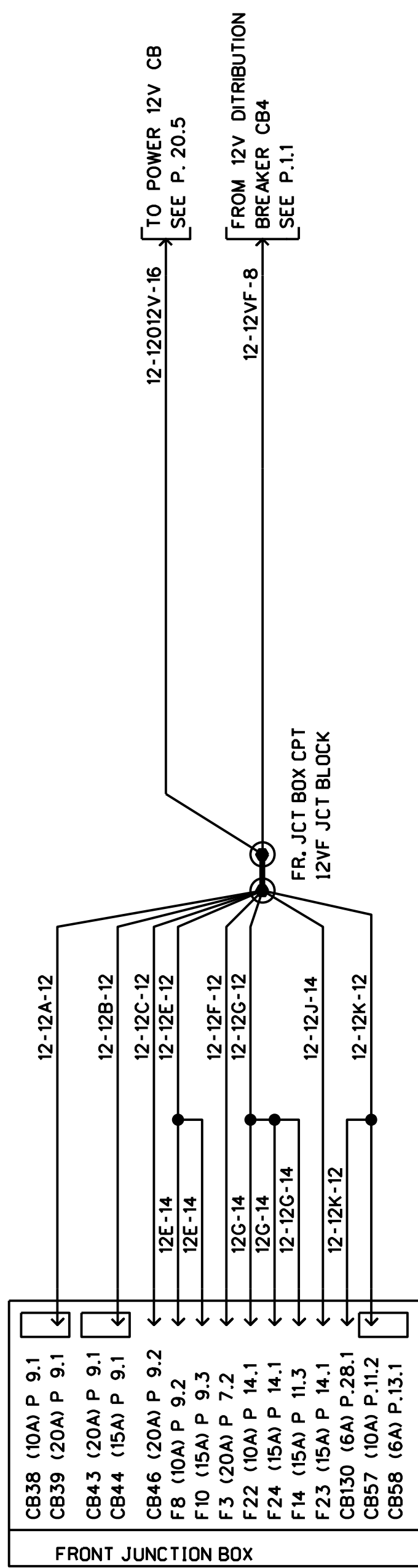

12V BATT. DISCONN. SW.

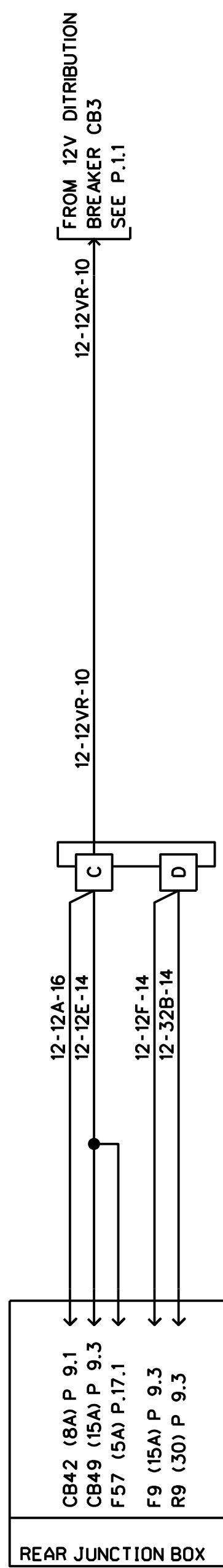

12V IGNITION

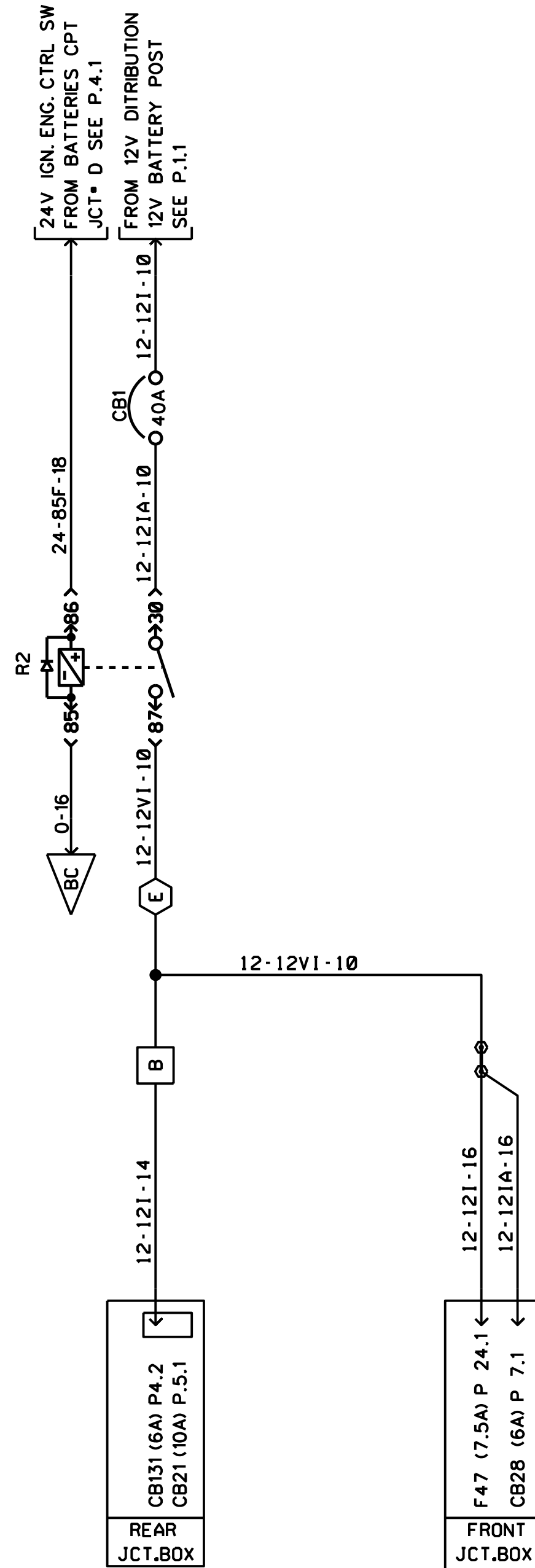

12V HOT WIRE

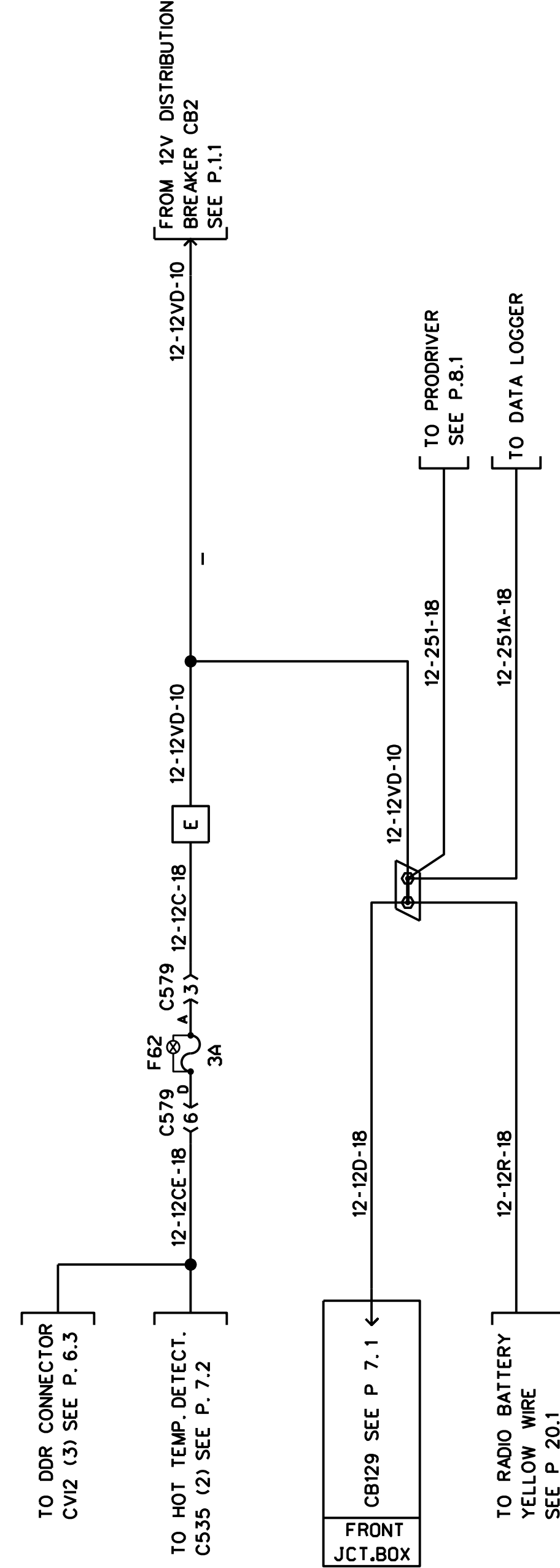

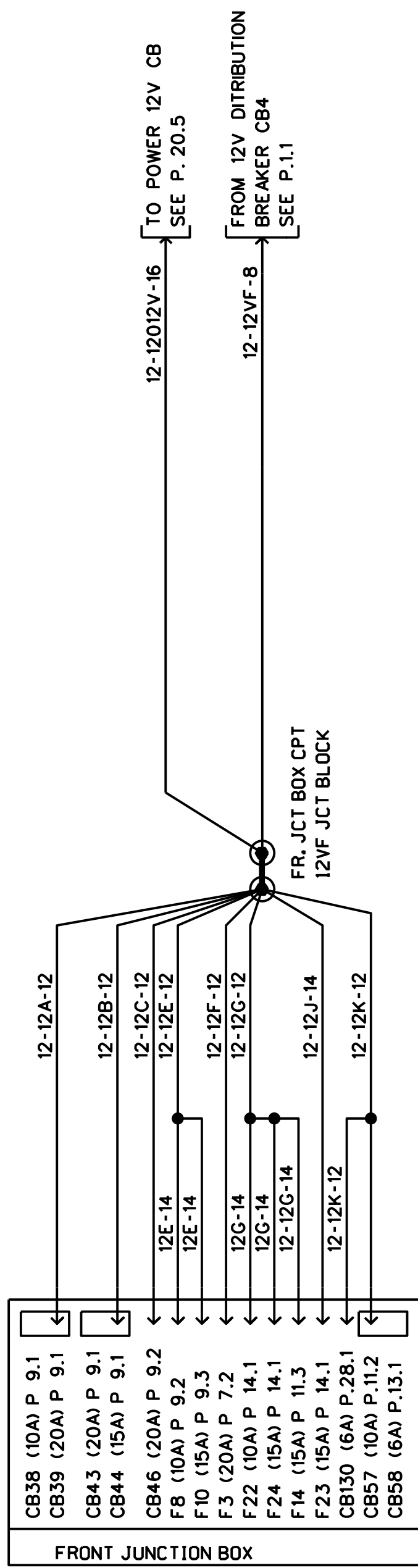

12V BATT. DISCONN. SW.

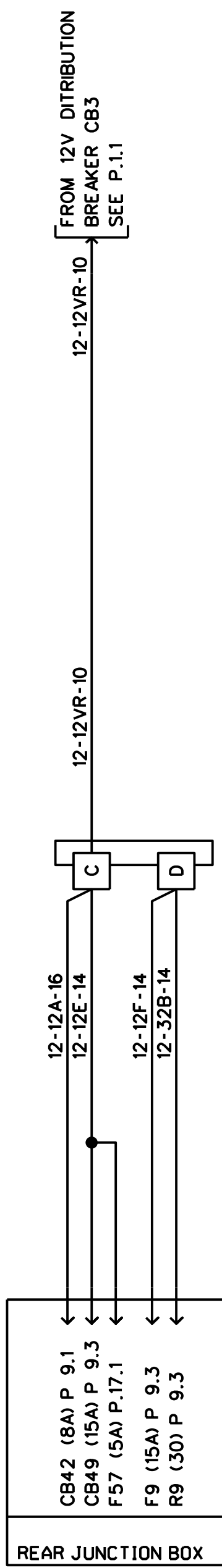

12V IGNITION

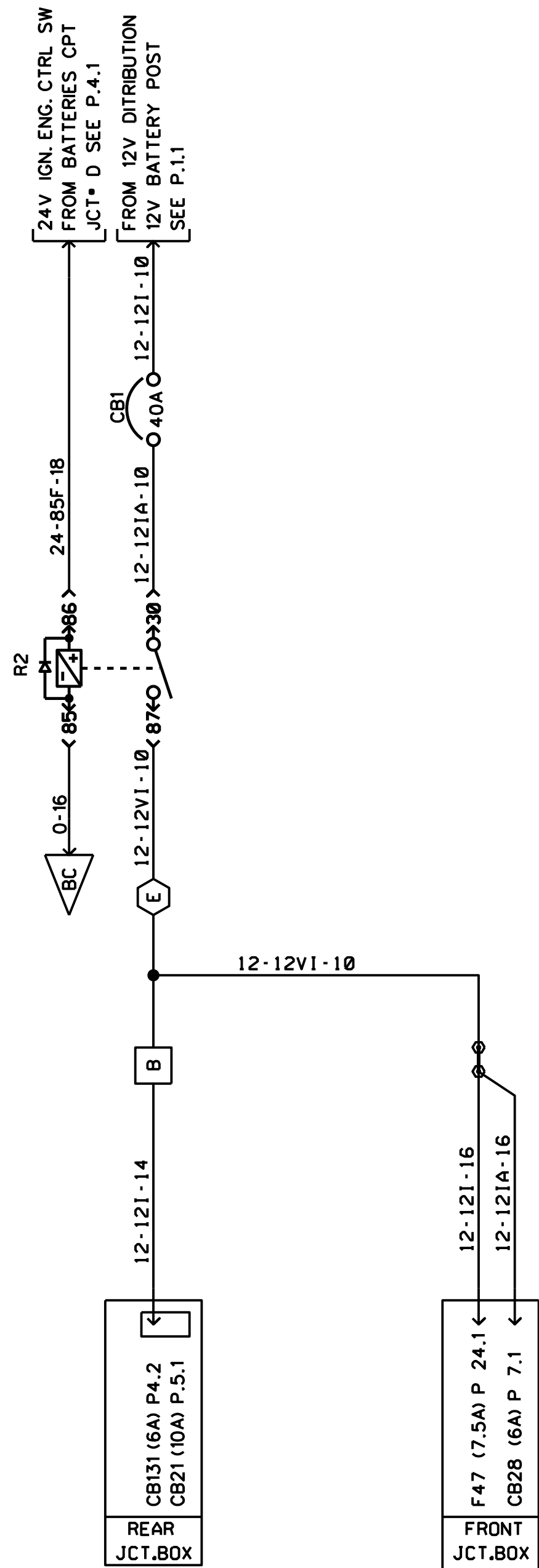

12V HOT WIRE

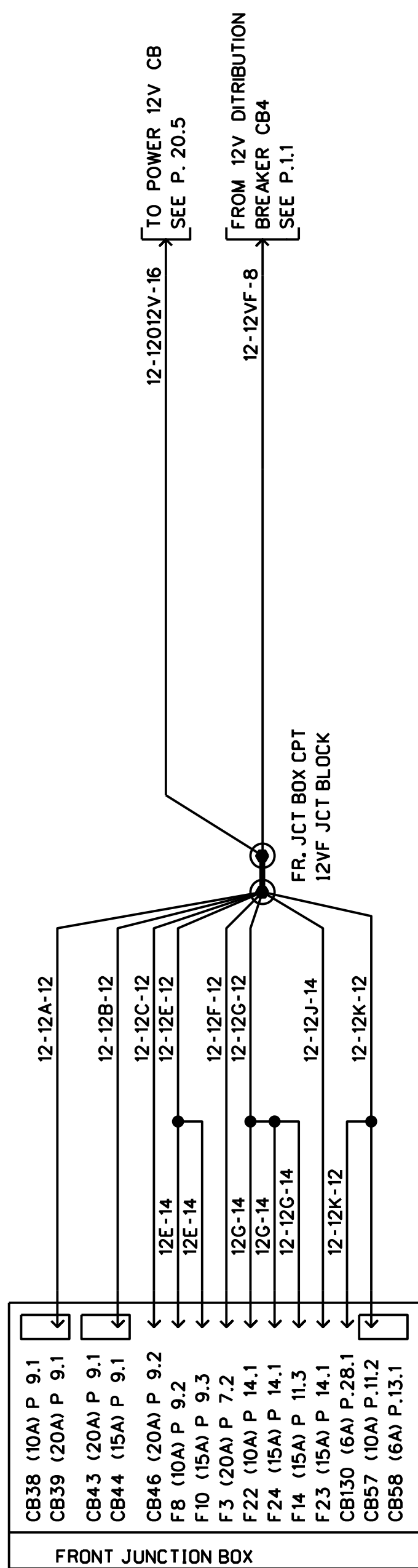

12V BATT. DISCONN. SW.

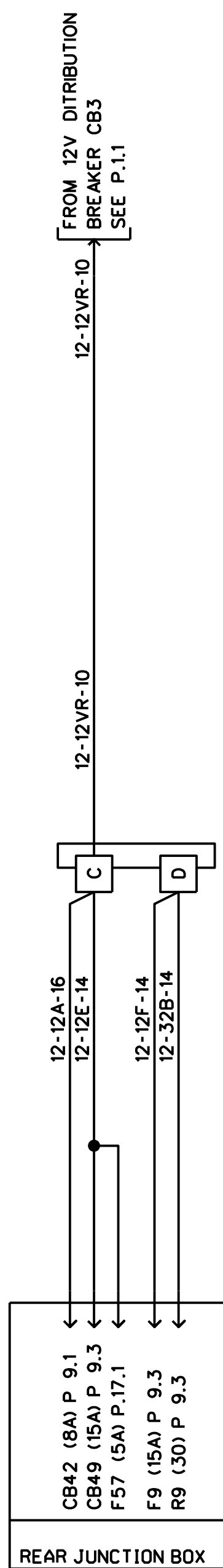

12V IGNITION

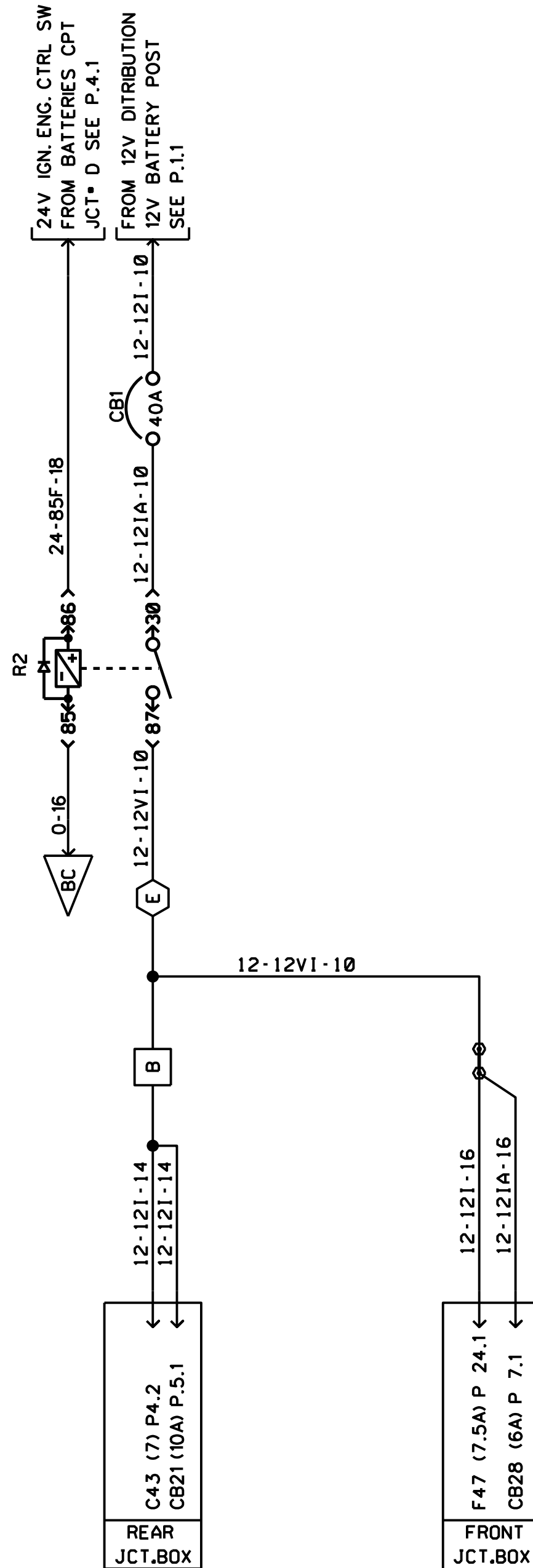

12V HOT WIRE

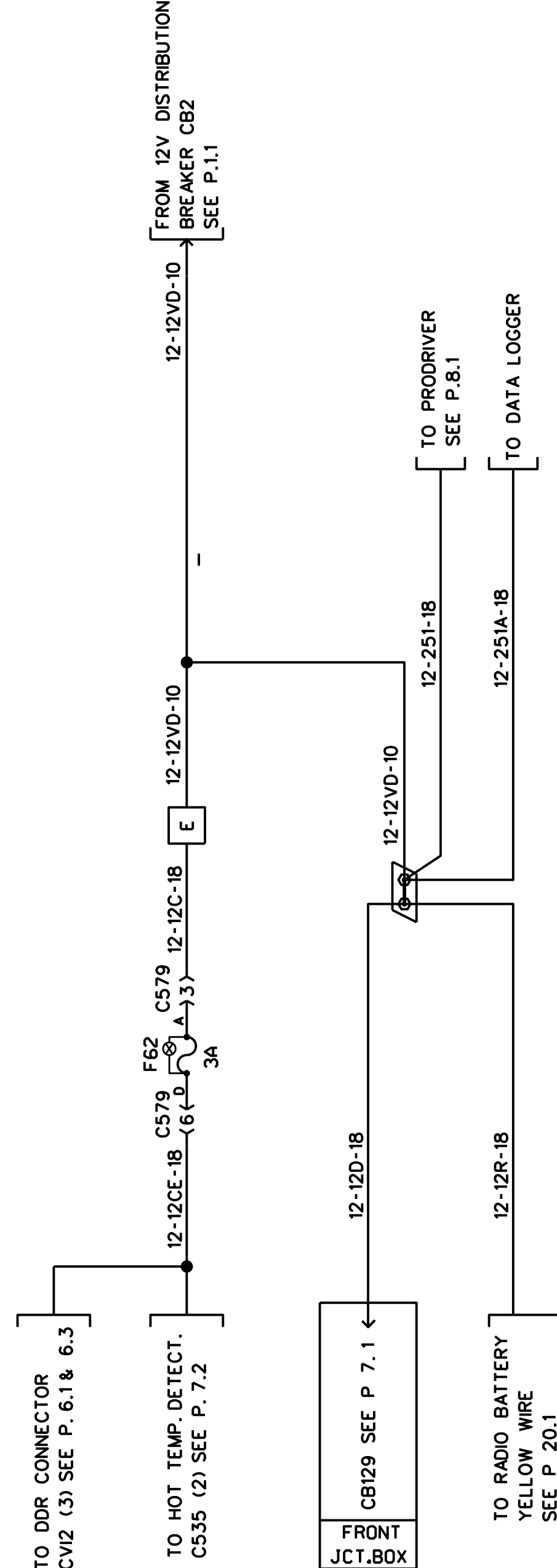

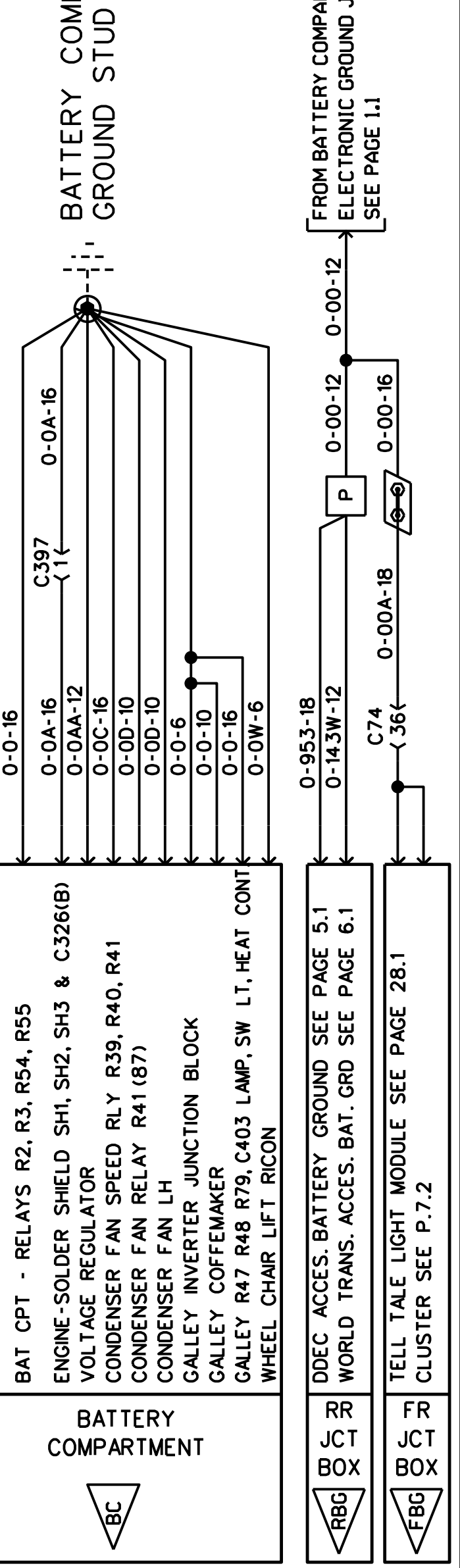
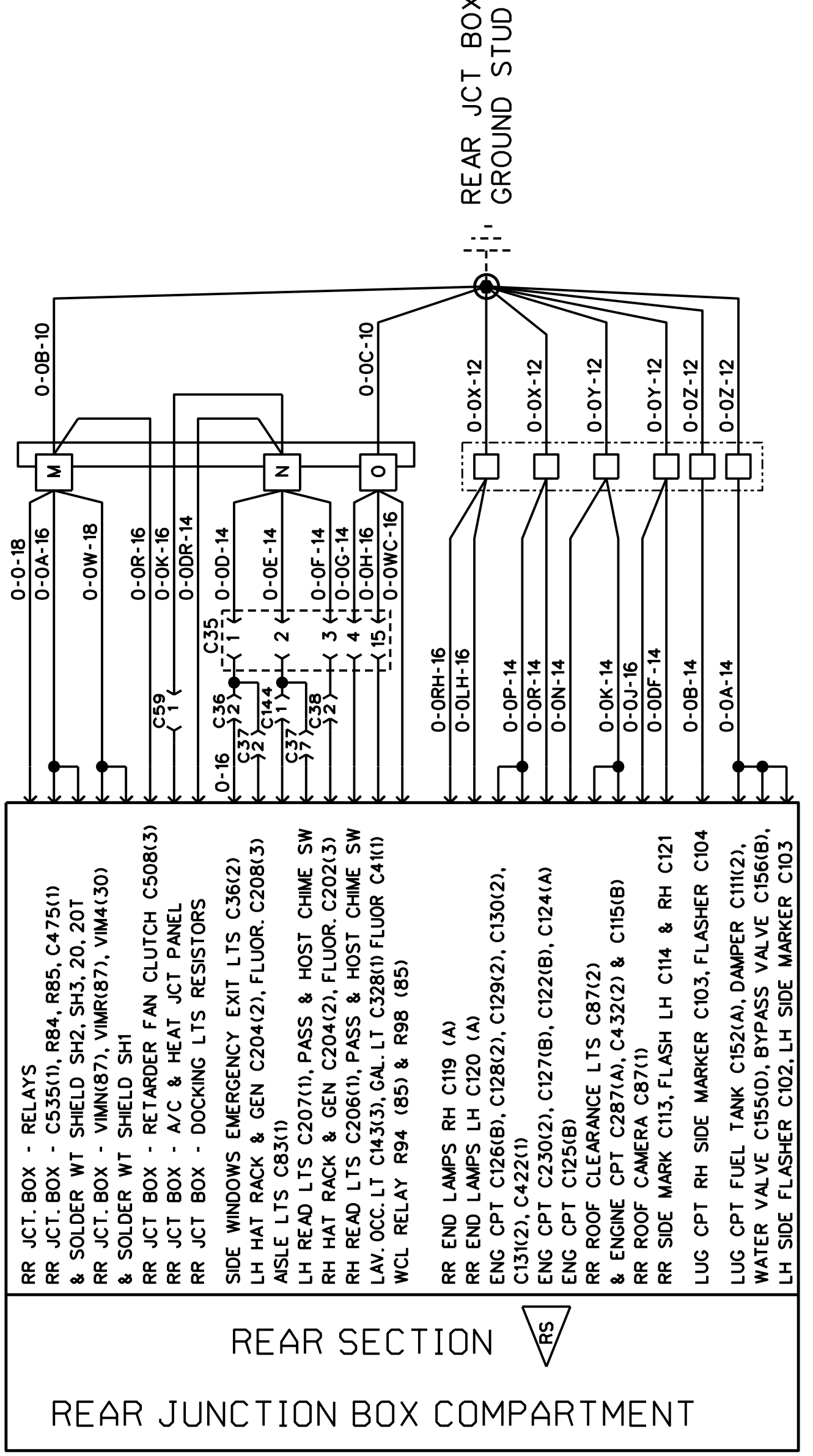
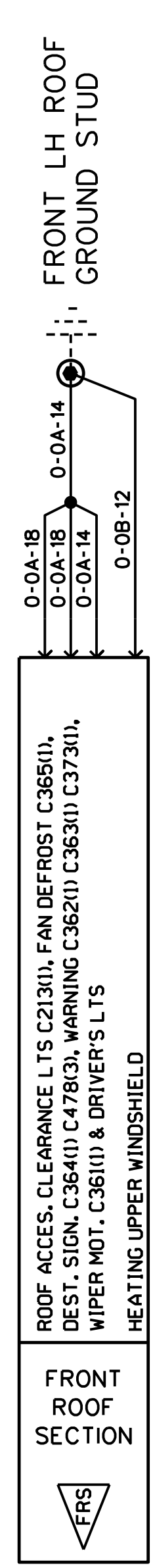
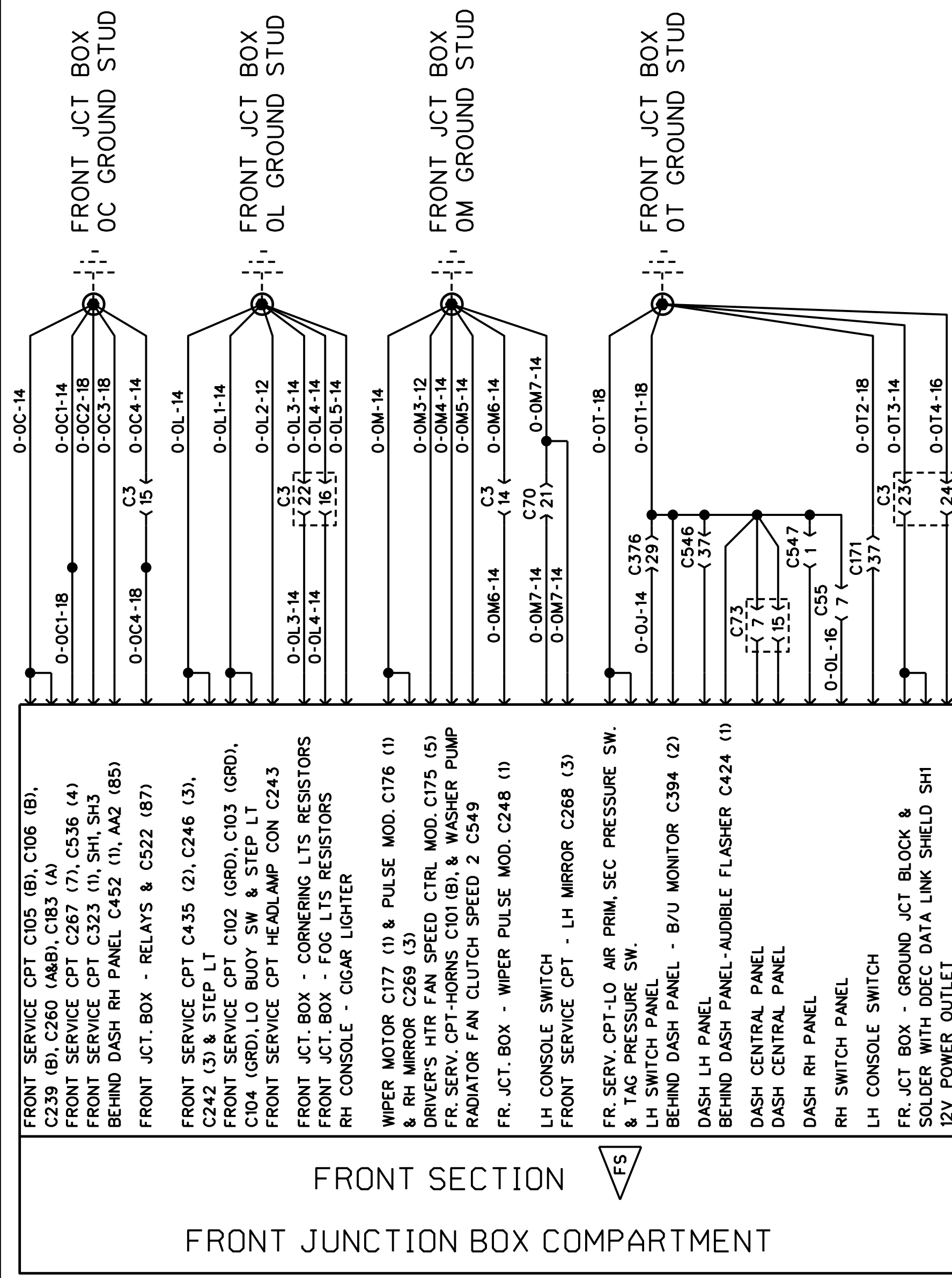

CHASSIS GROUND

BATTERY GROUND

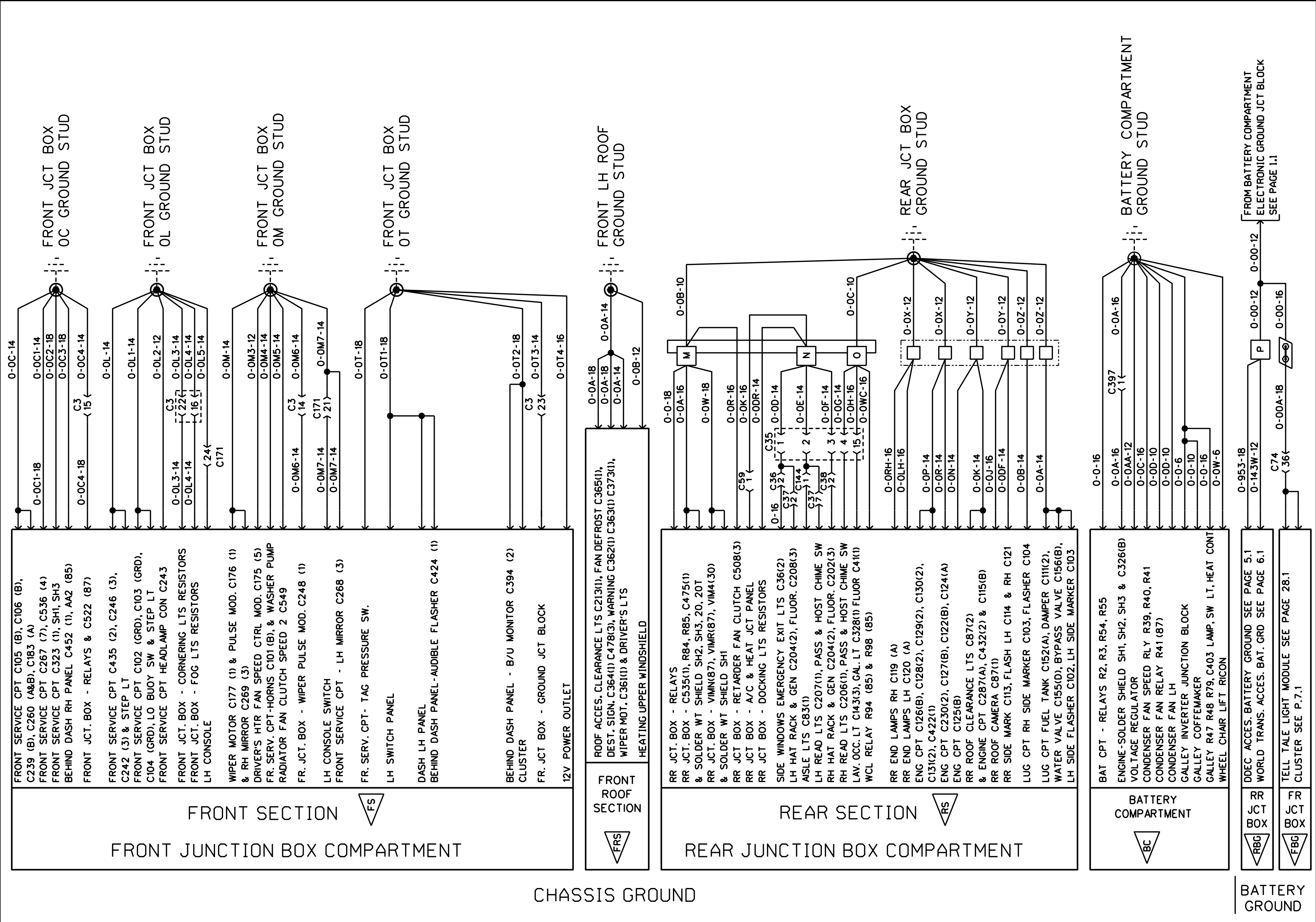

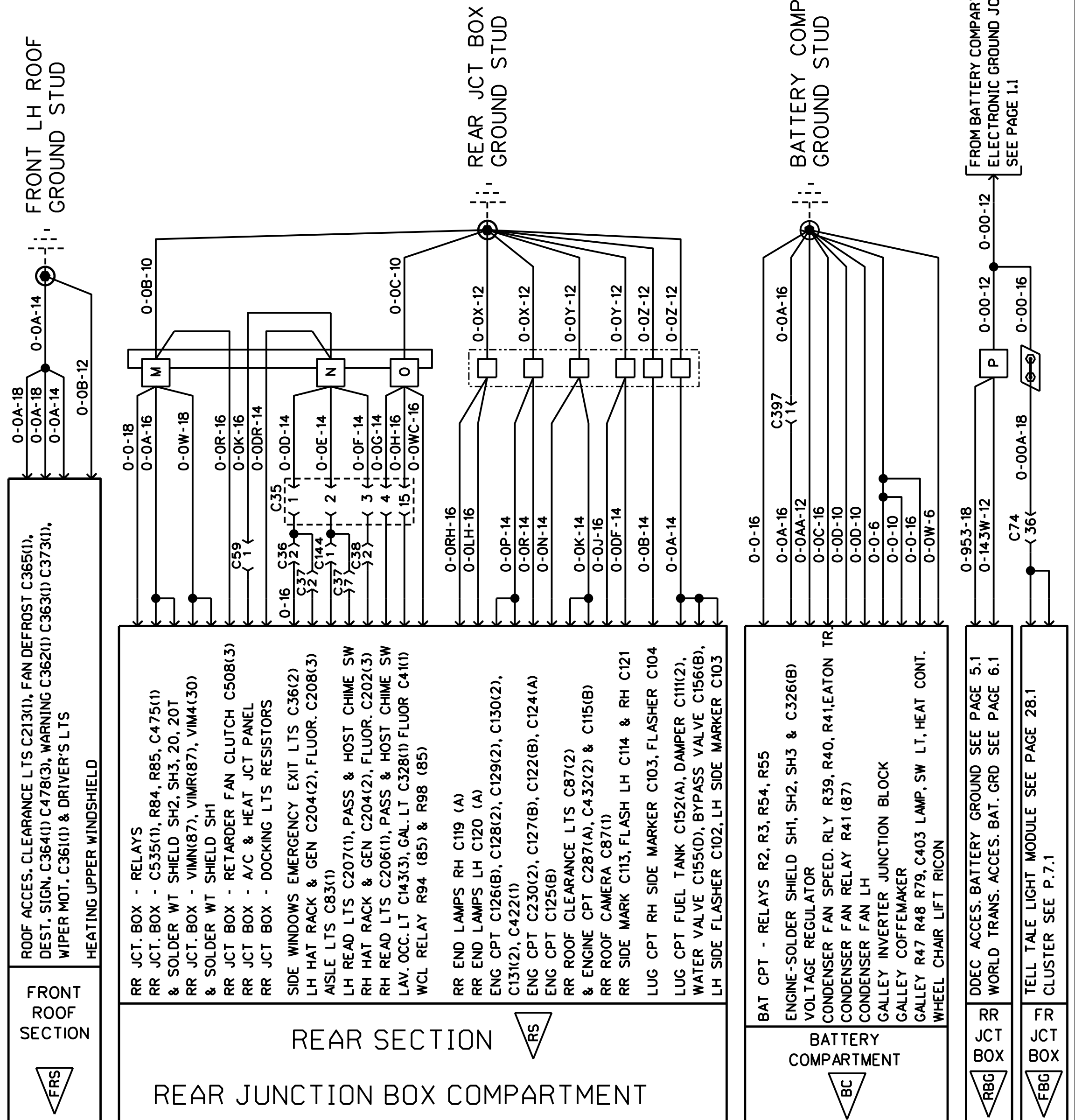
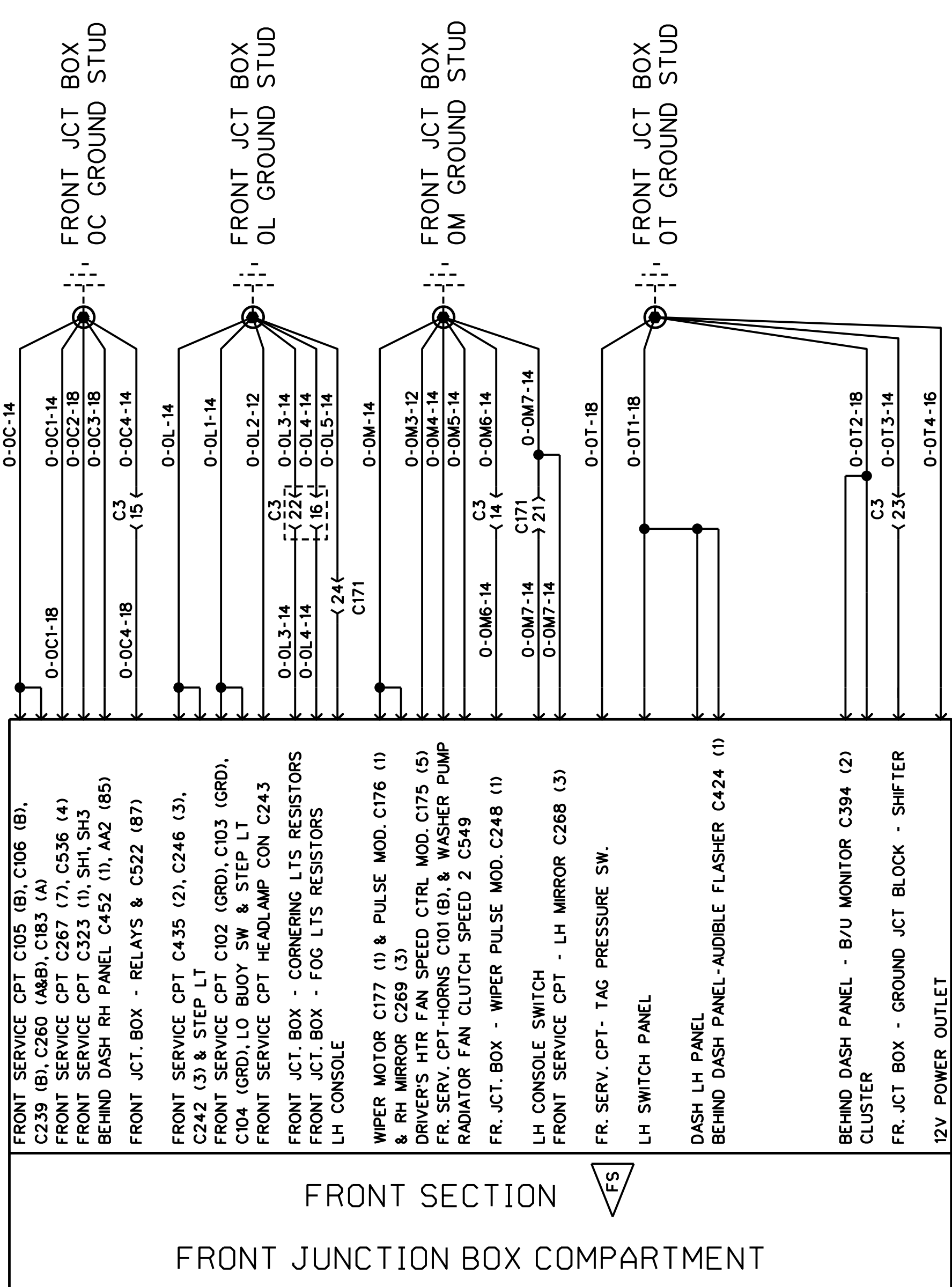

CHASSIS GROUND



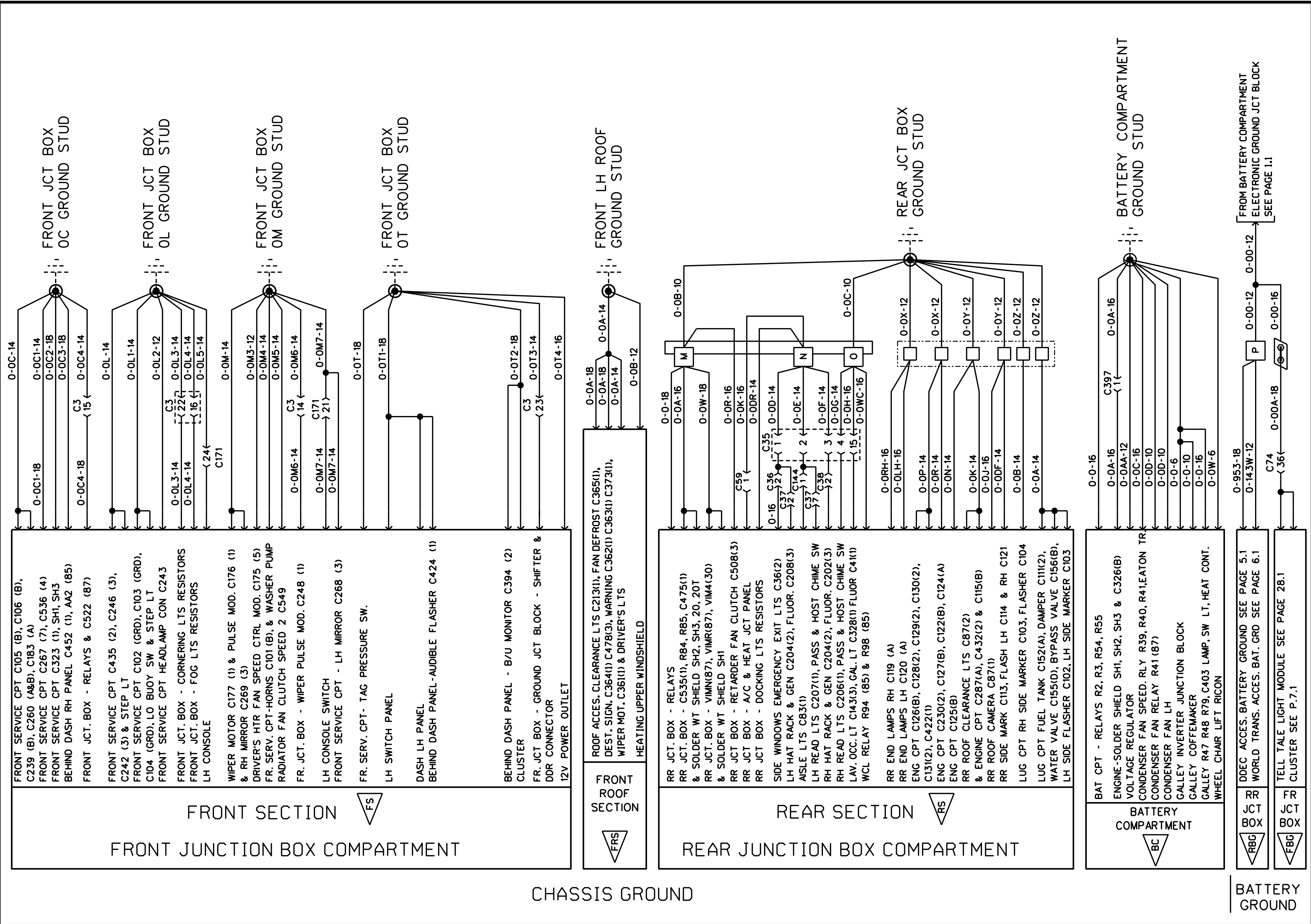

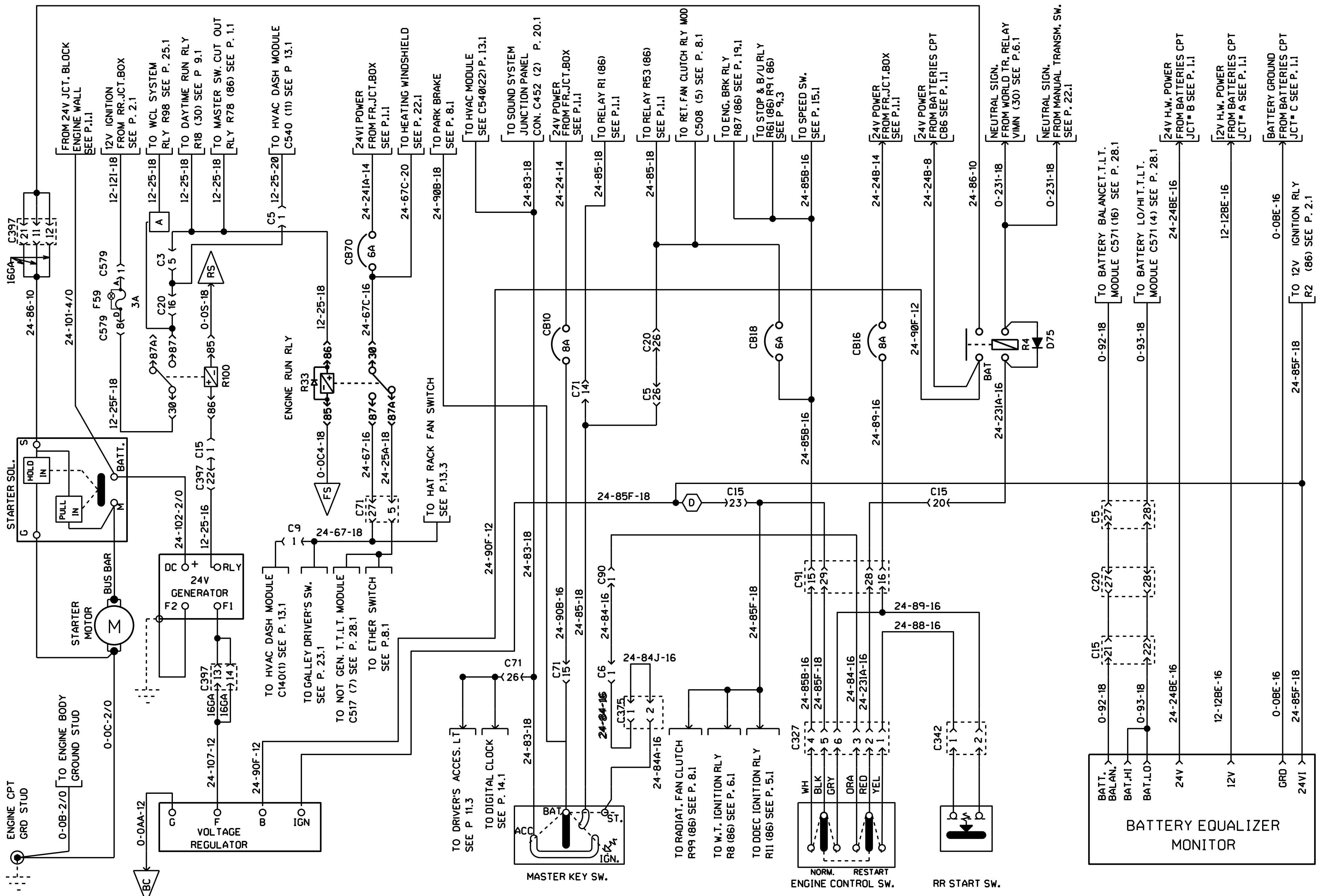

CHARGING SYSTEM

&

ENGINE CONTROL

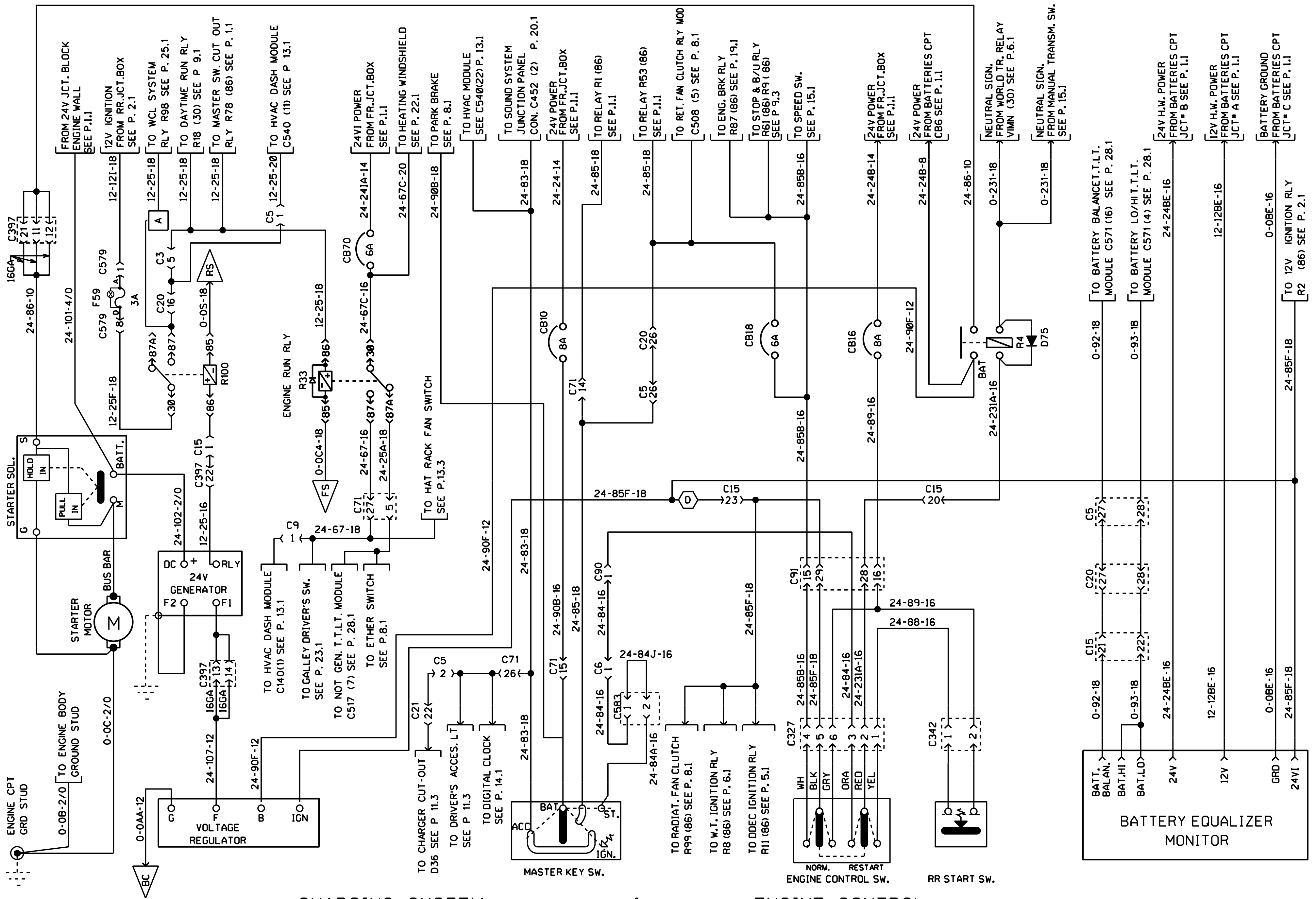

CHARGING SYSTEM

&

ENGINE CONTROL

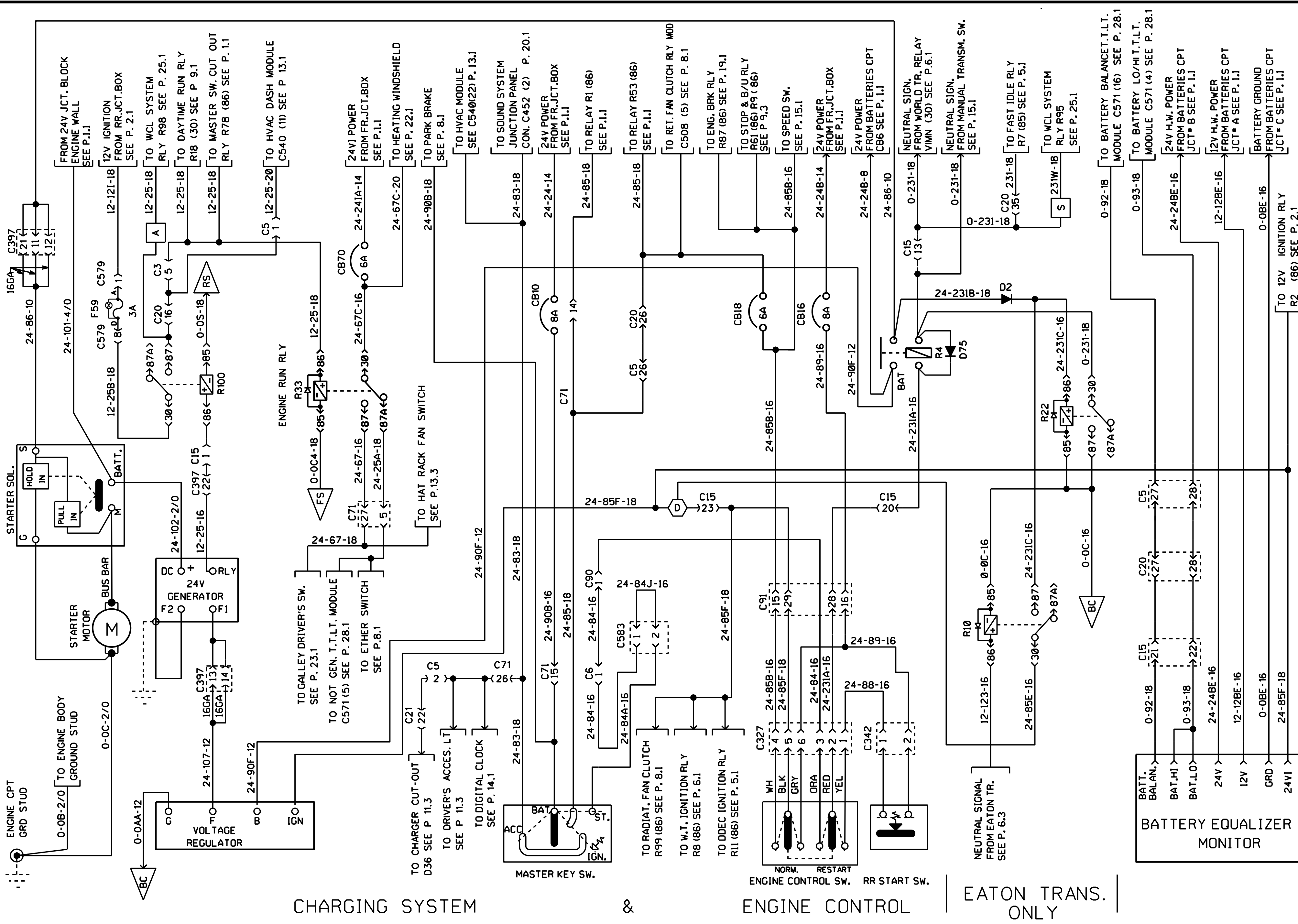

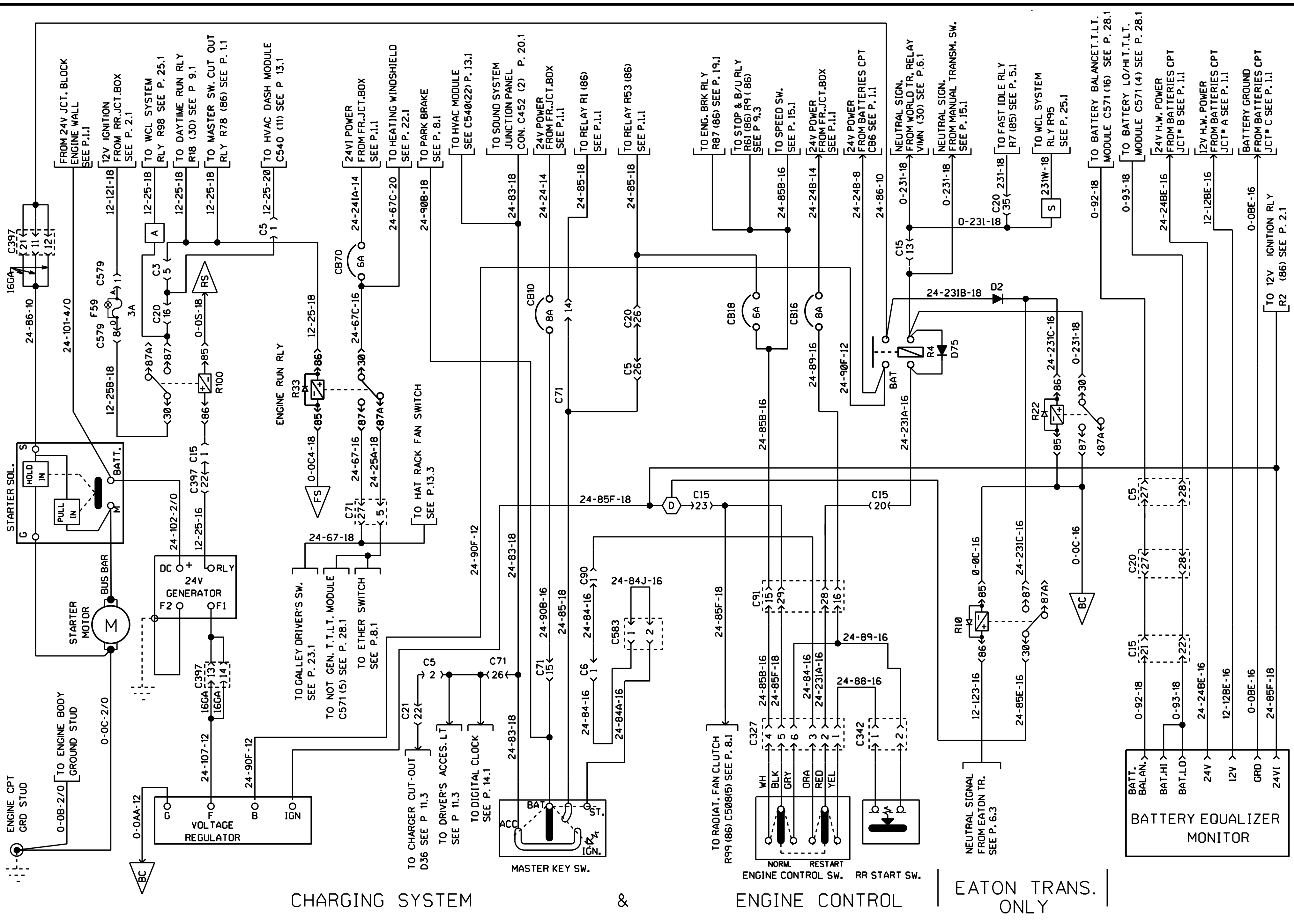

CHARGING SYSTEM

&

ENGINE CONTROL

EATON TRANS. ONLY

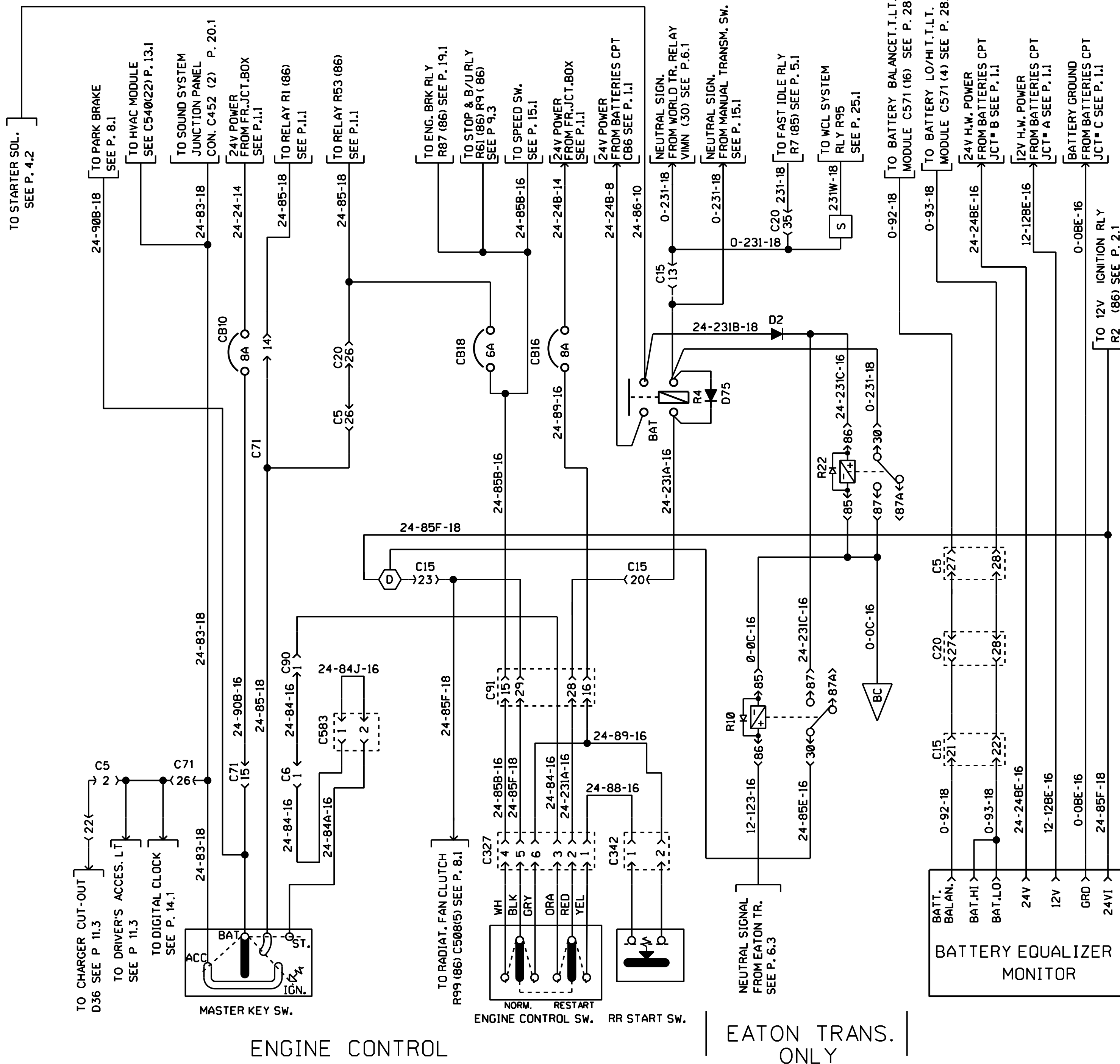

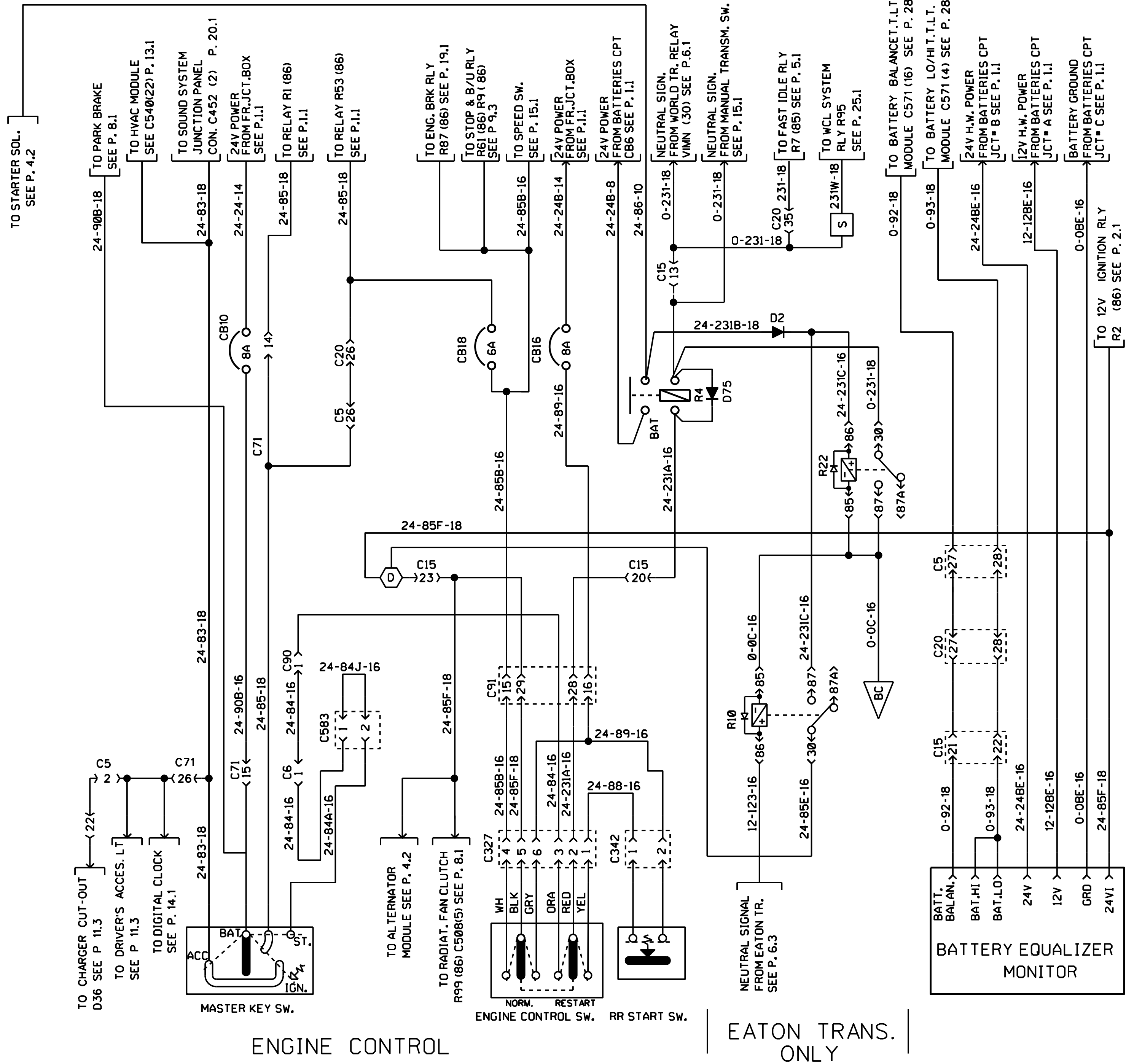



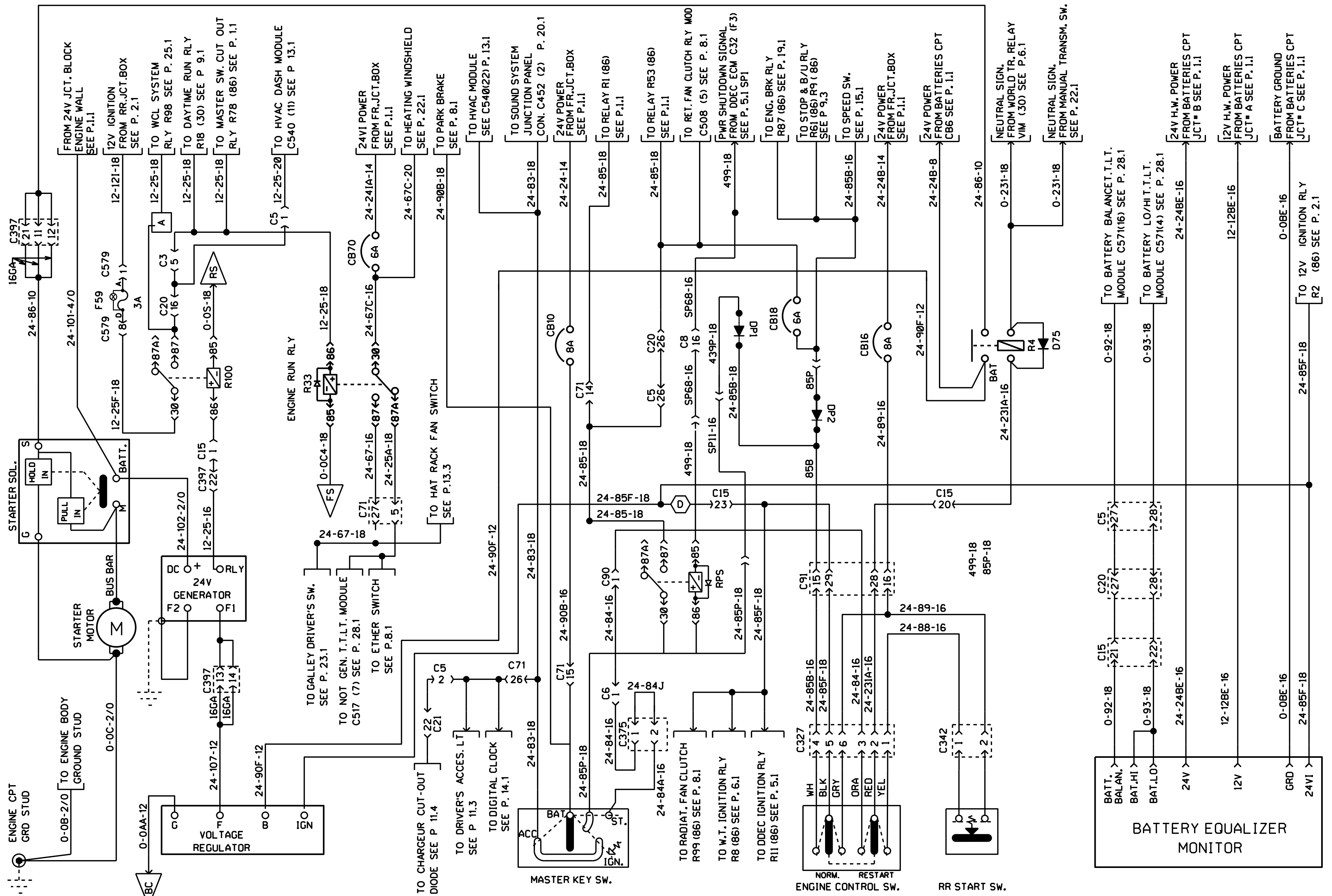

SPECIAL CHARGING SYSTEM & ENGINE CONTROL WITH POWER SHUTDOWN & IDLER TIMER

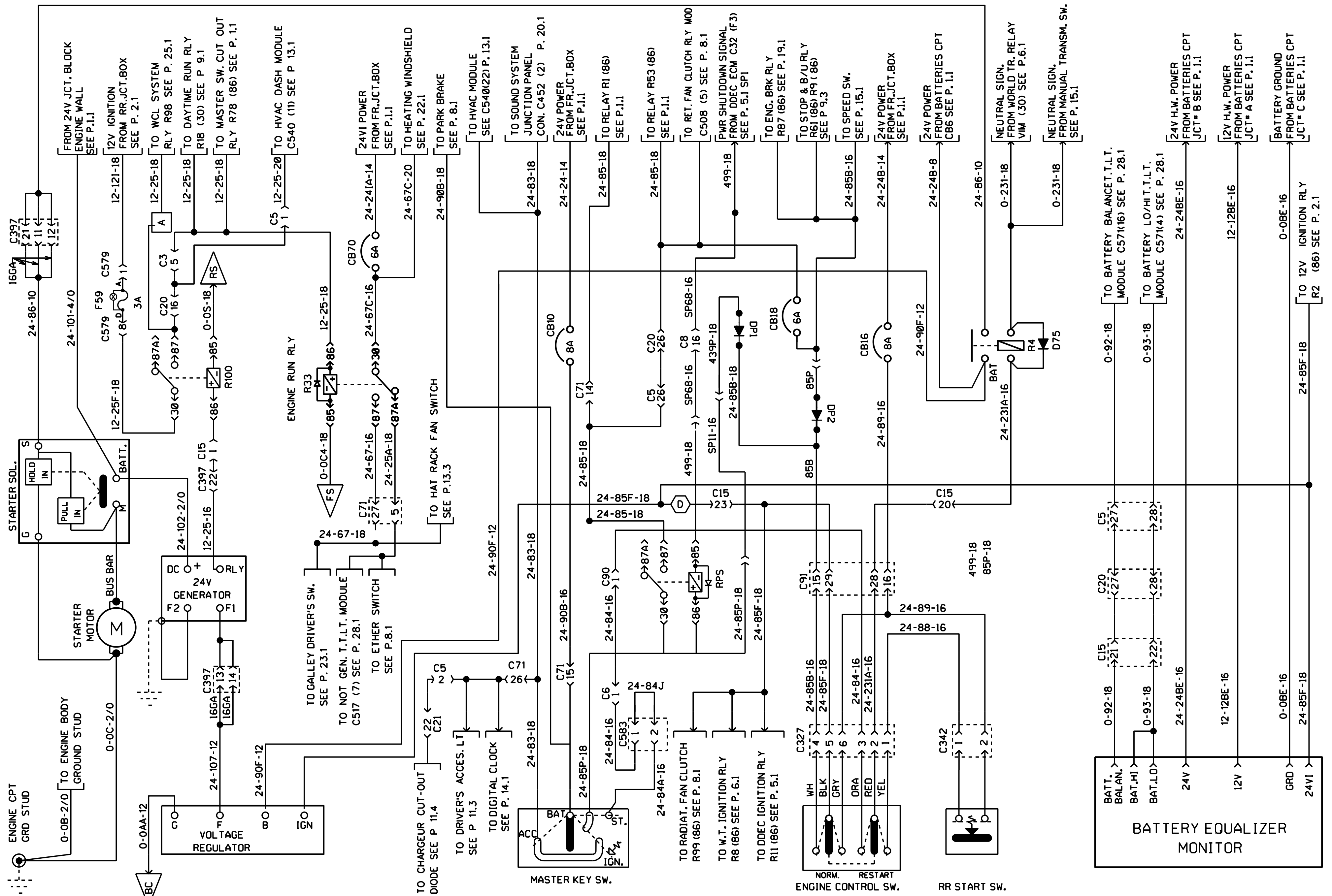

SPECIAL CHARGING SYSTEM & ENGINE CONTROL WITH POWER SHUTDOWN & IDLER TIMER

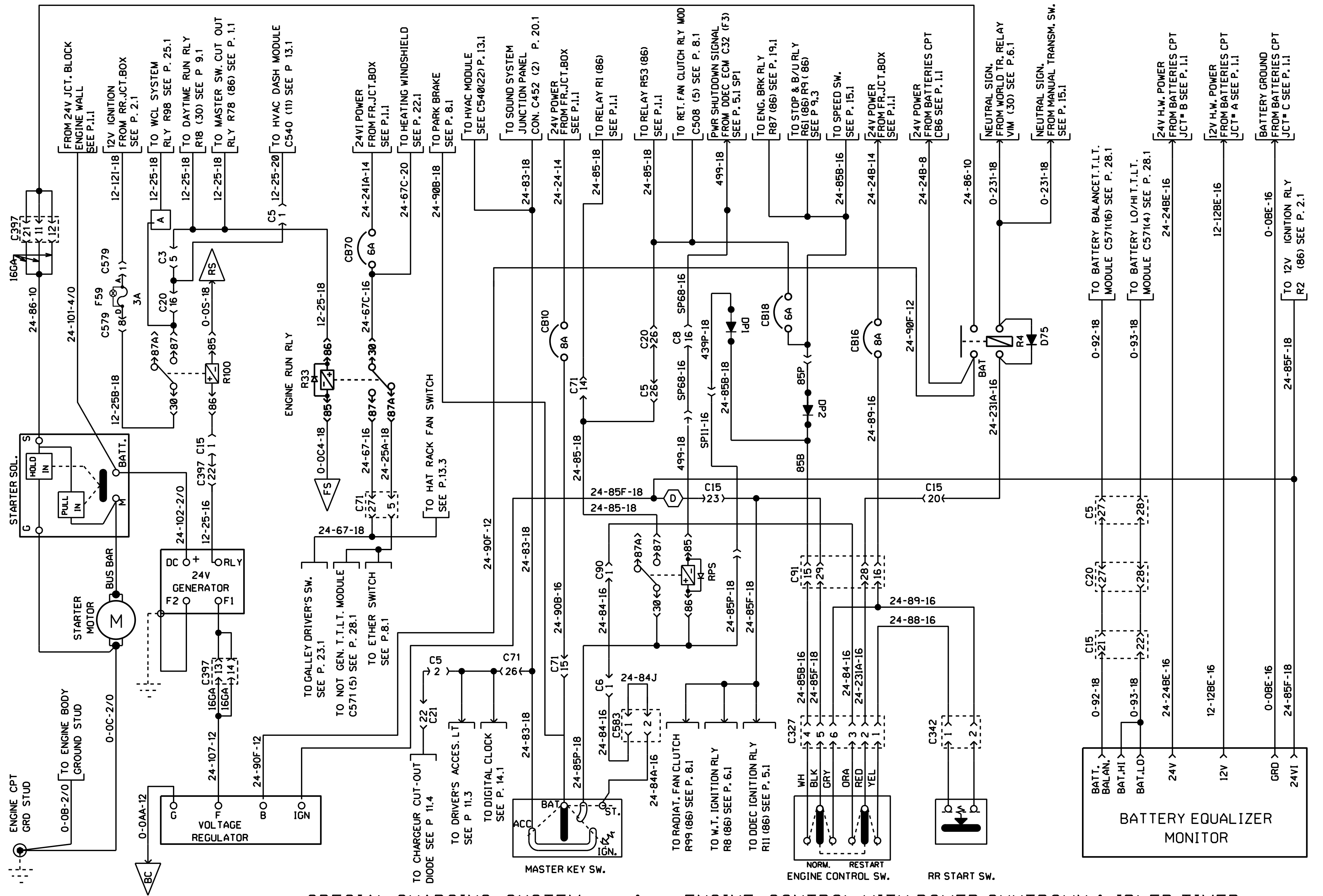

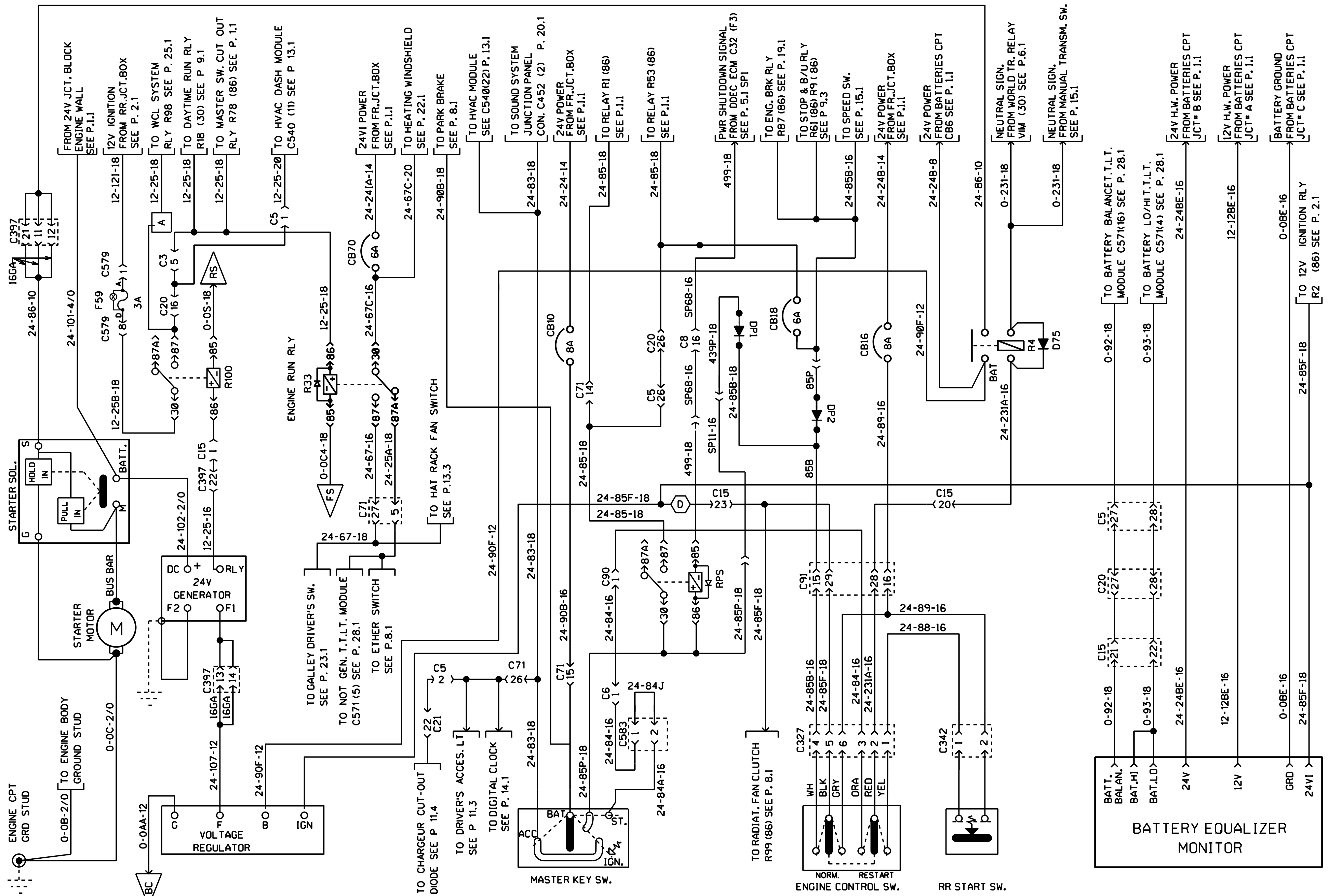

SPECIAL CHARGING SYSTEM & ENGINE CONTROL WITH POWER SHUTDOWN & IDLER TIMER

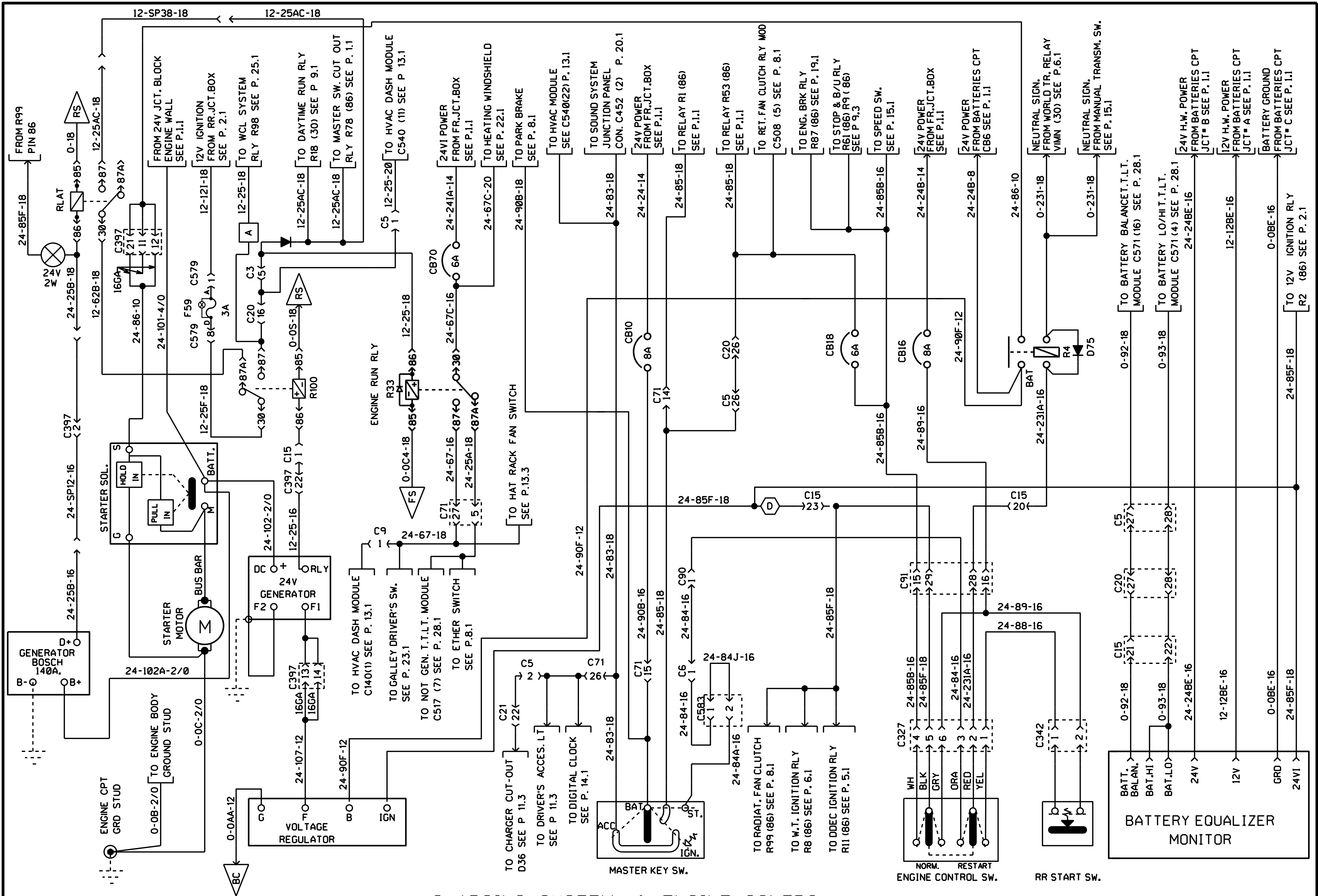

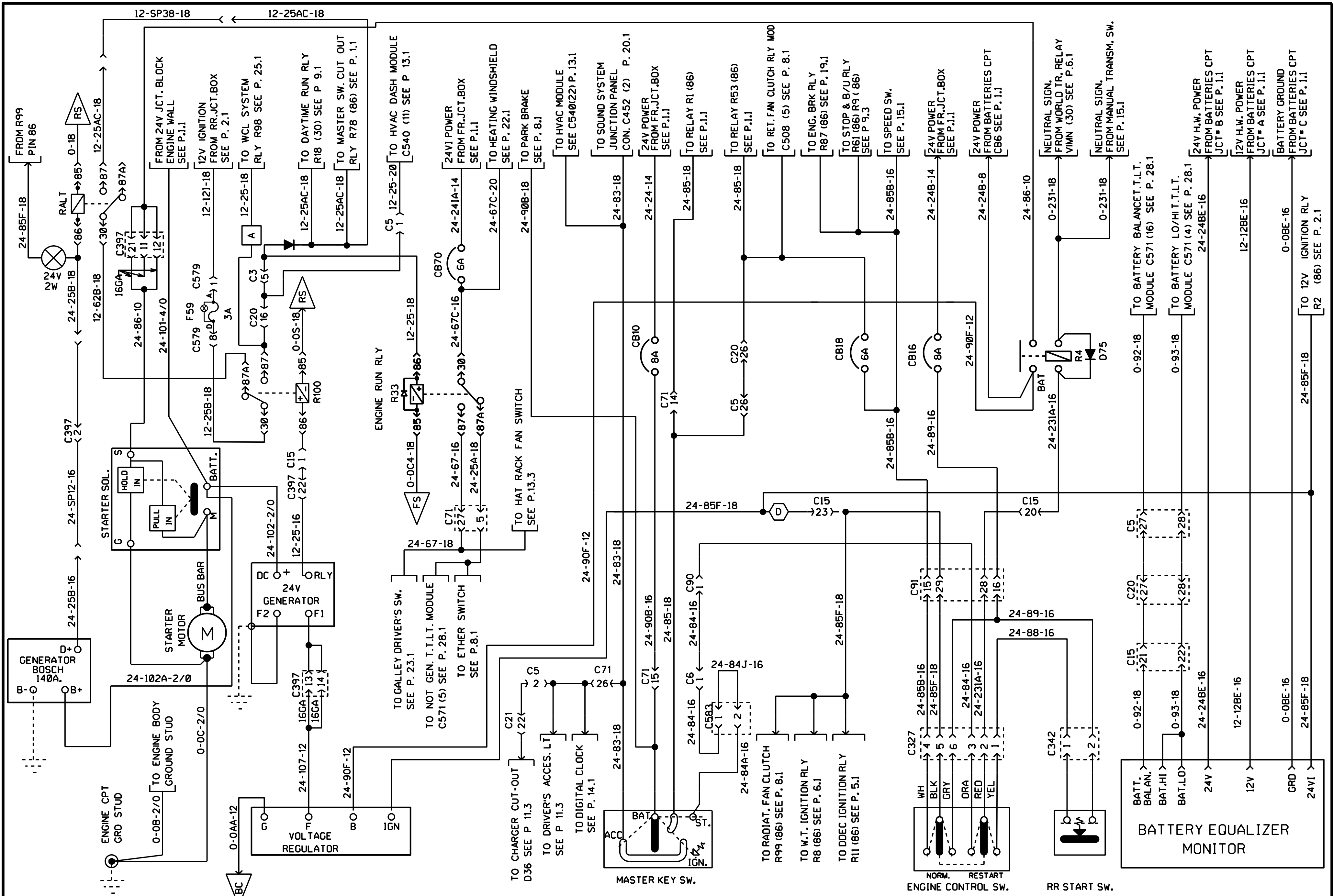

GENERATOR ADDITIONAL

CHARGING SYSTEM & ENGINE CONTROL

**PREVOST**

WIRING DIAGRAM

NO:

0060902

PAGE: 4.1sp2

REVISION  
08

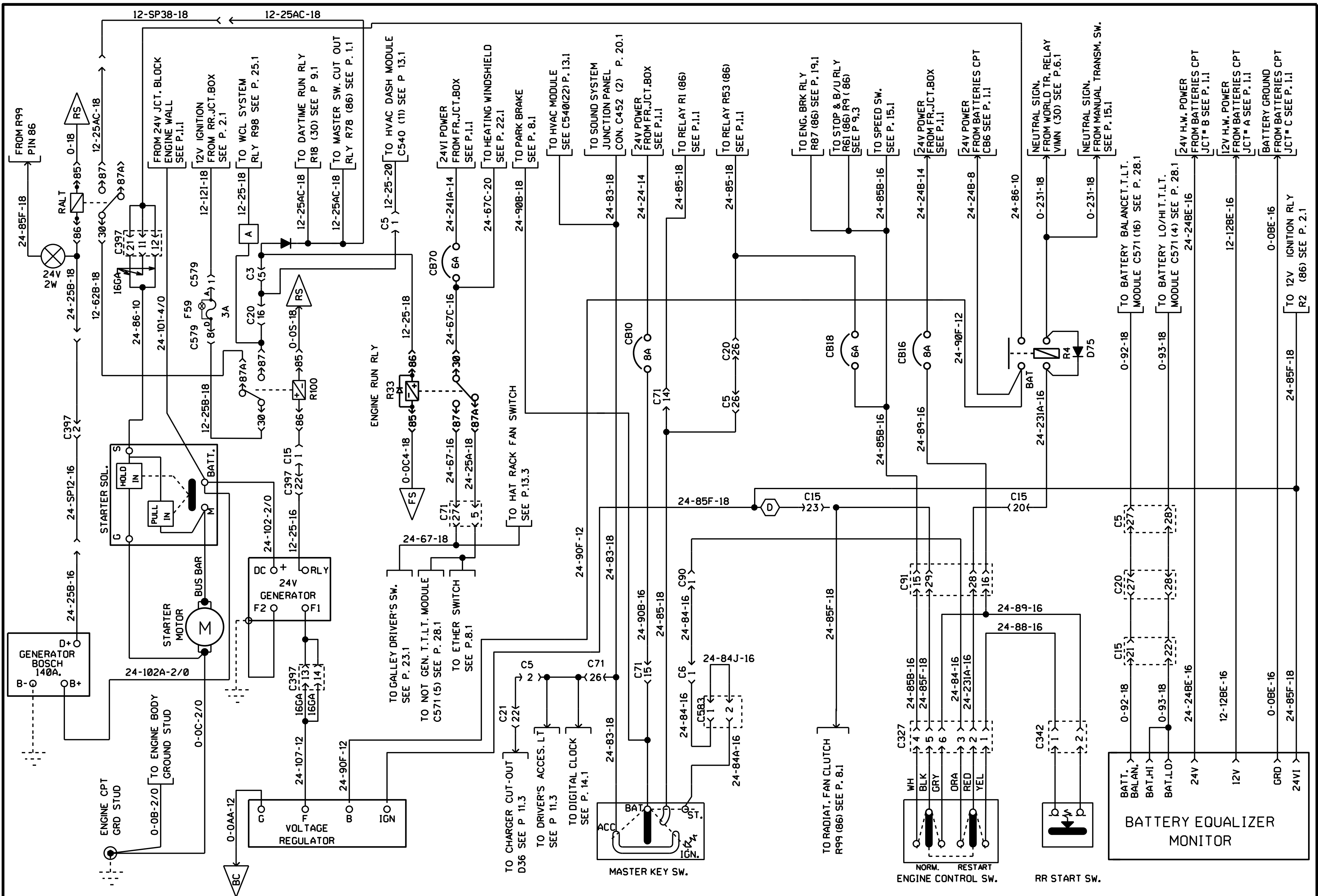

GENERATOR ADDITIONAL

CHARGING SYSTEM & ENGINE CONTROL



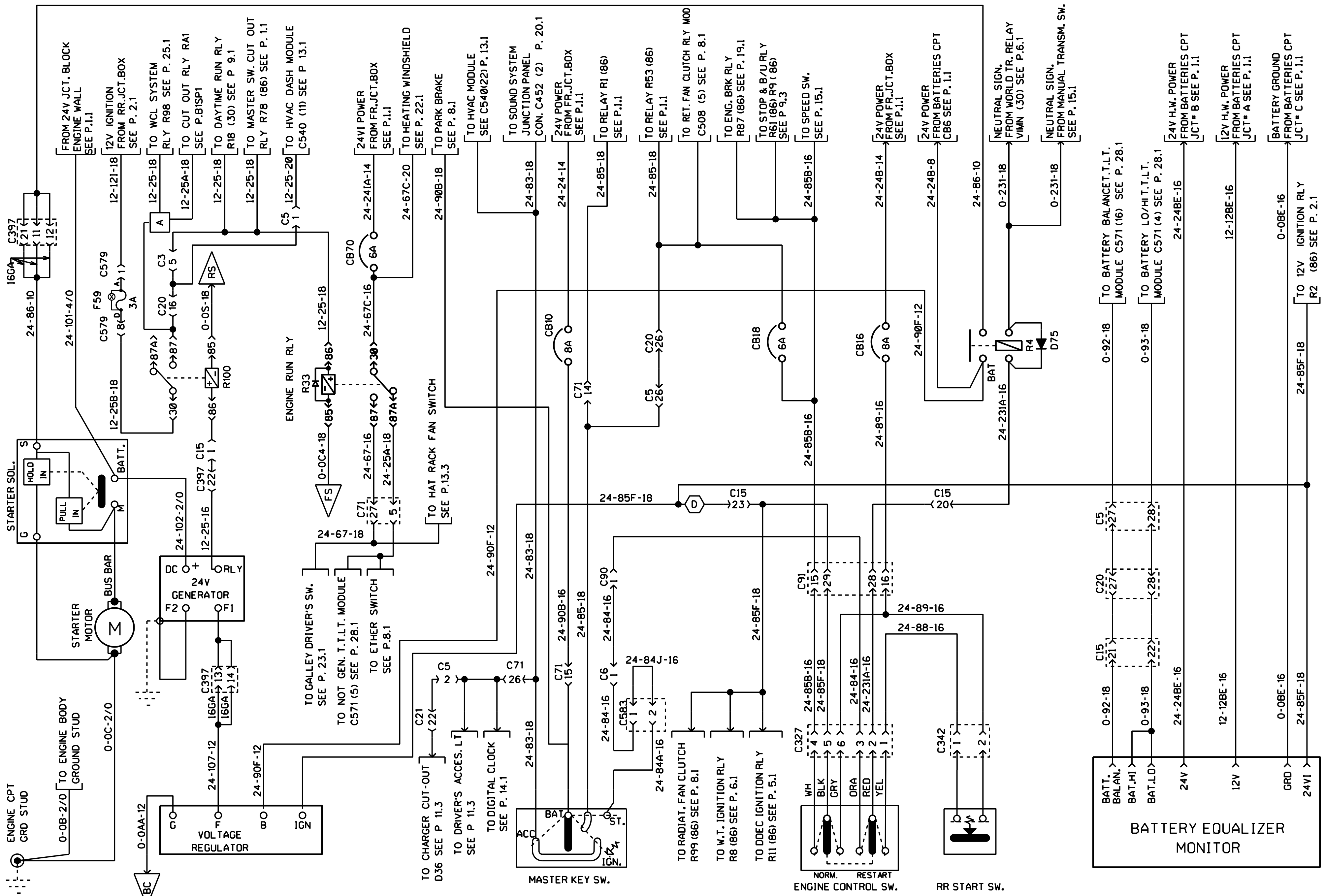

CHARGING SYSTEM

&

ENGINE CONTROL

ORLEANS & ADIRONDACK

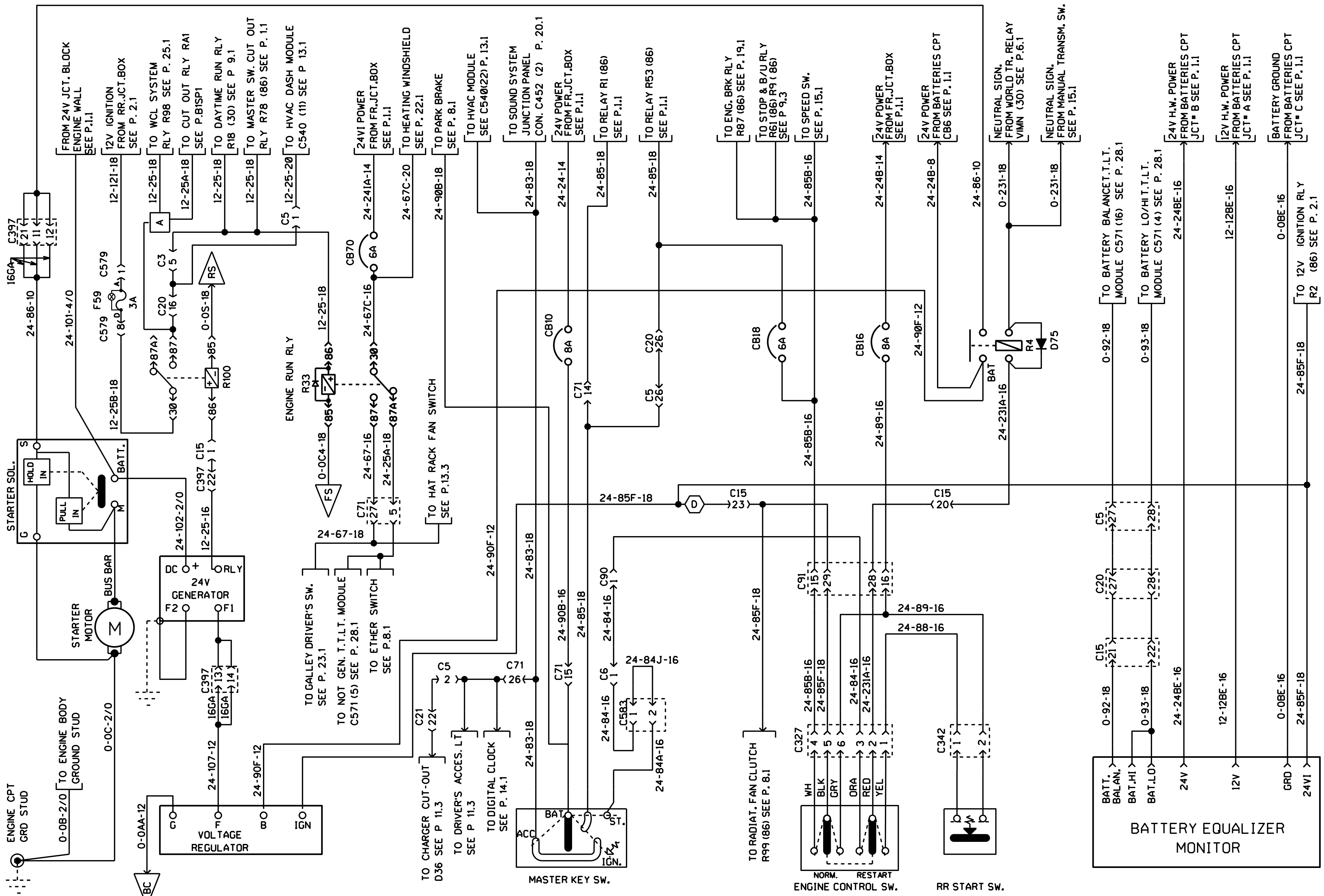

CHARGING SYSTEM

&

ENGINE CONTROL

ORLEANS & ADIRONDACK

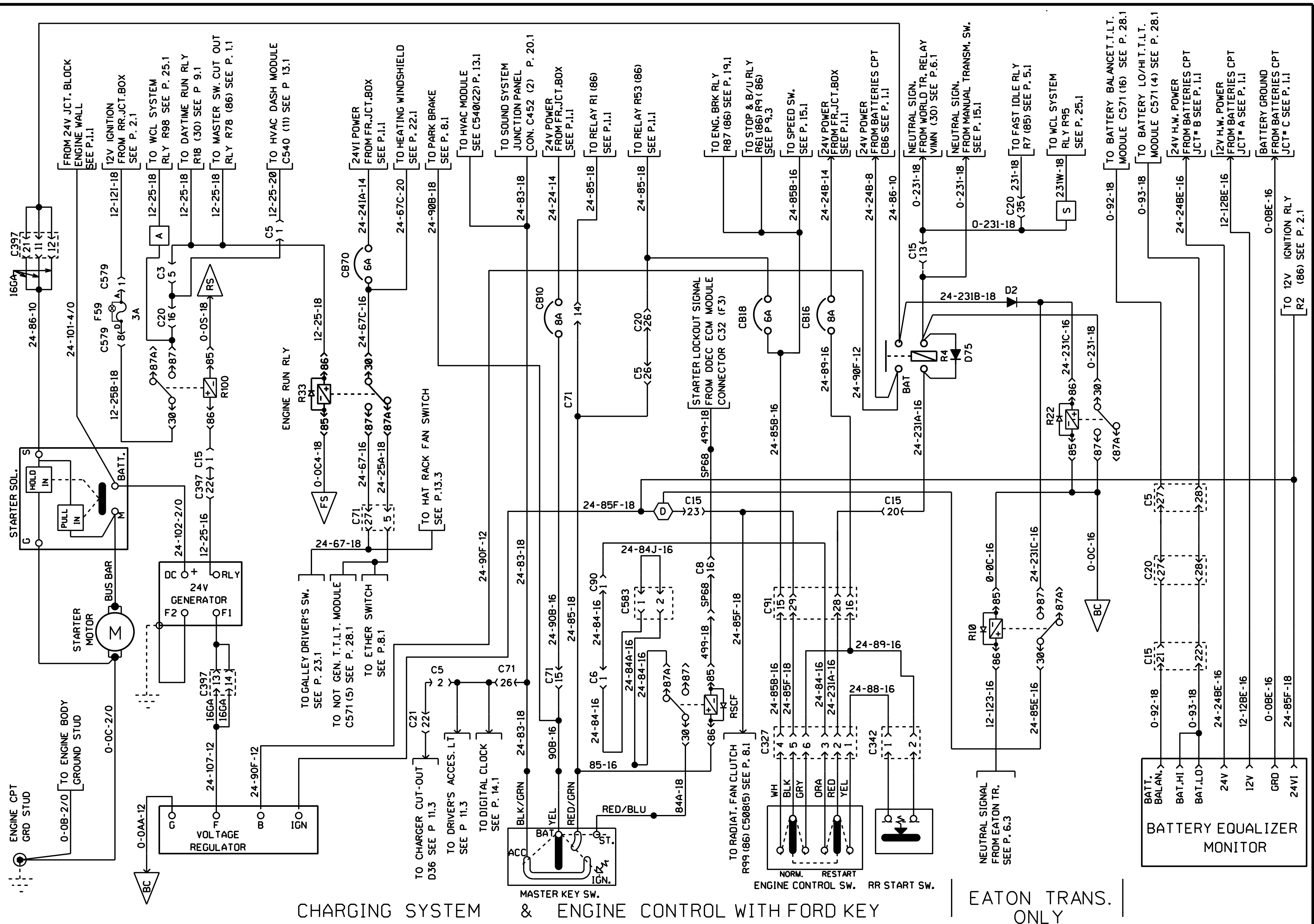

CHARGING SYSTEM

& ENGINE CONTROL WITH FORD KEY

EATON TRANS. ONLY

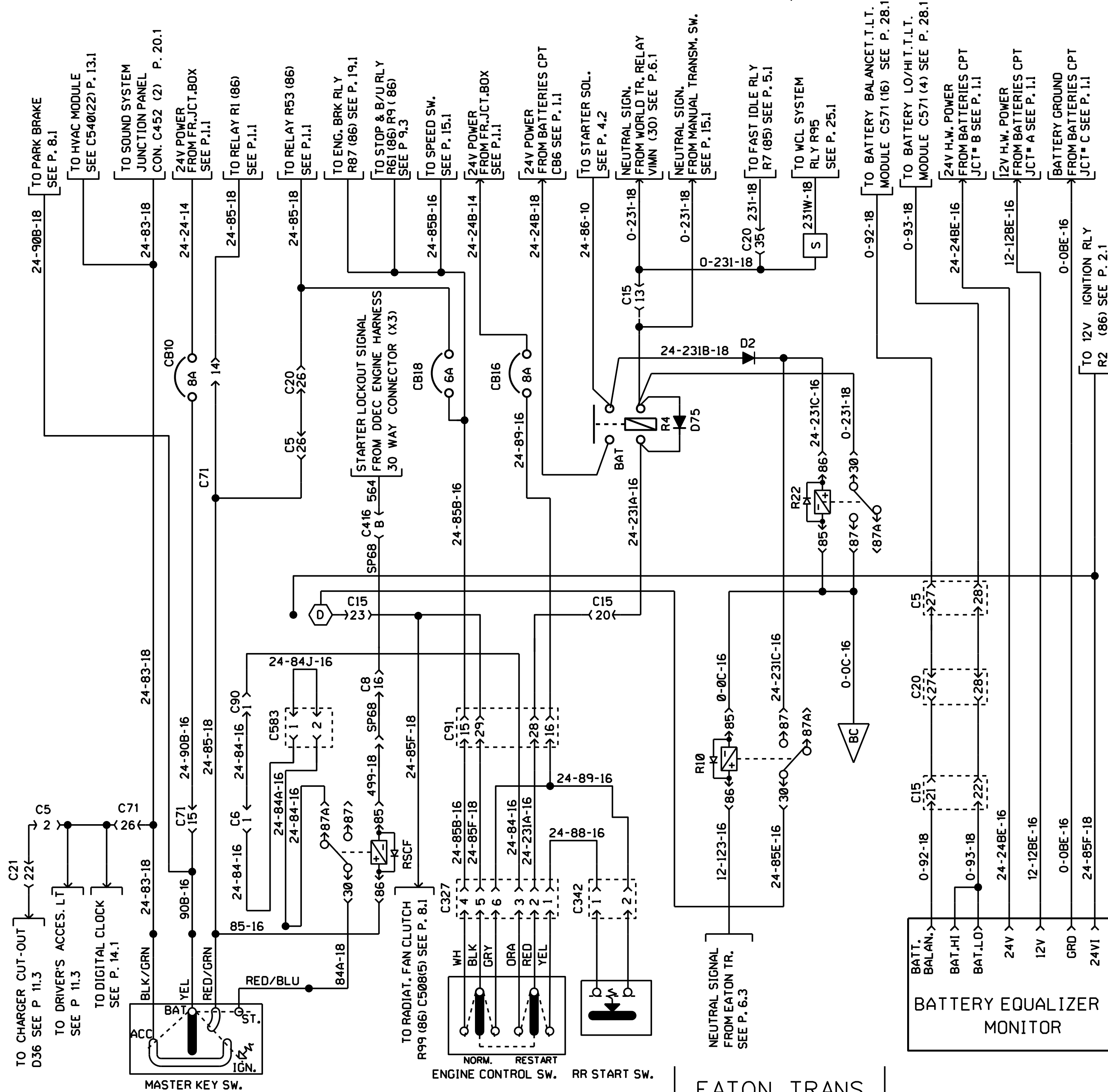

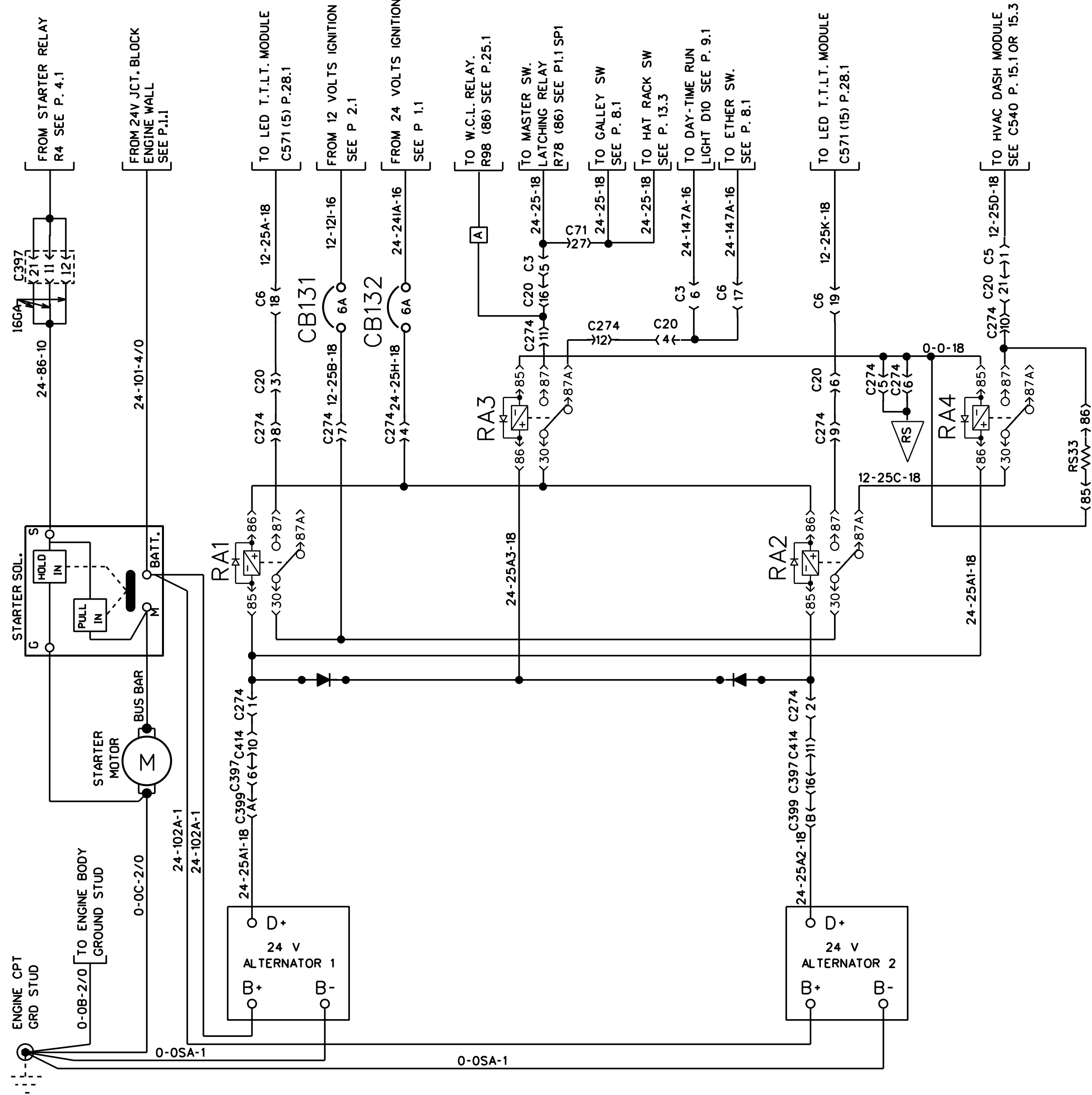

STARTER & ALTERNATOR BOSCH

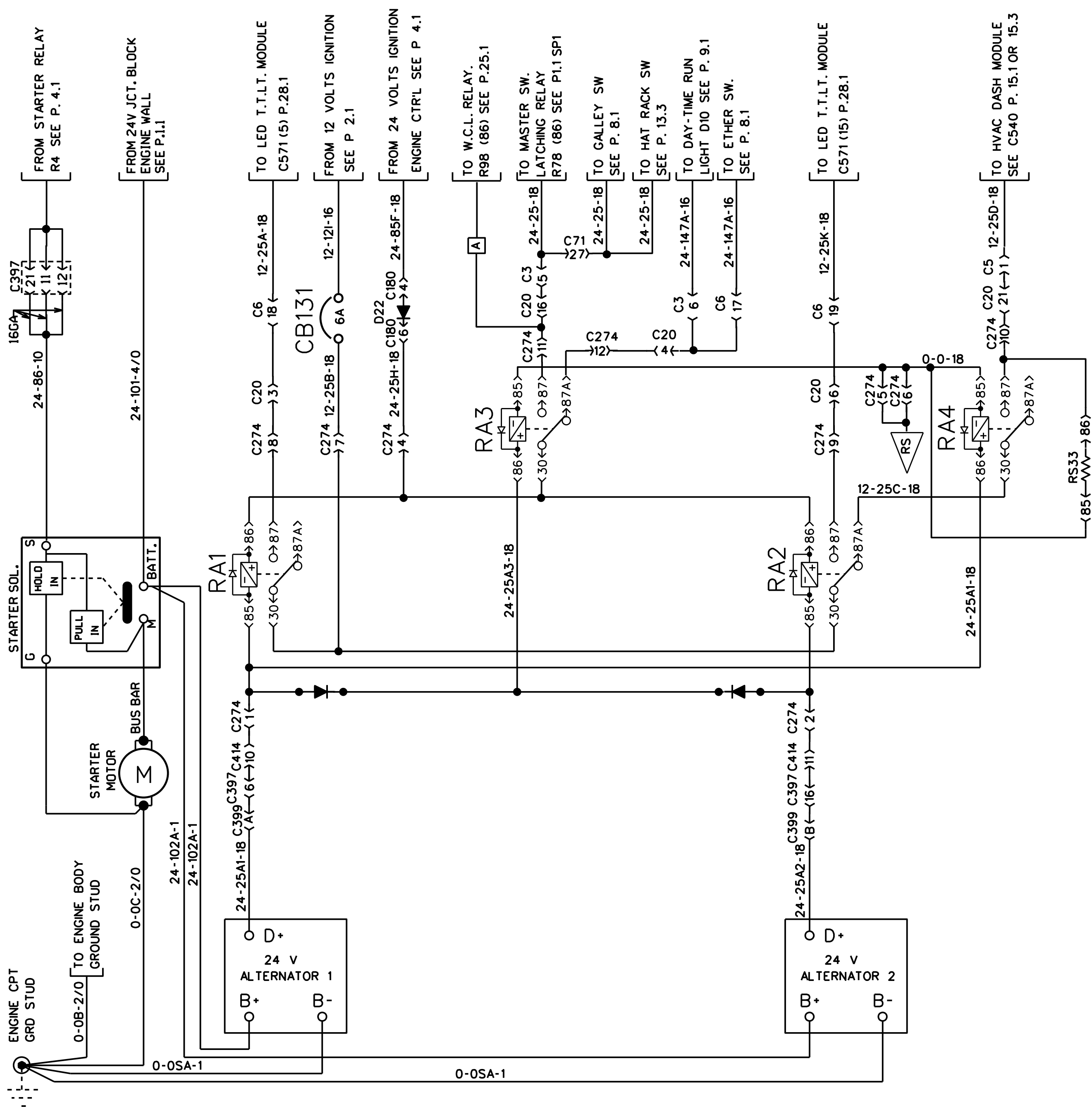

STARTER & ALTERNATOR BOSCH

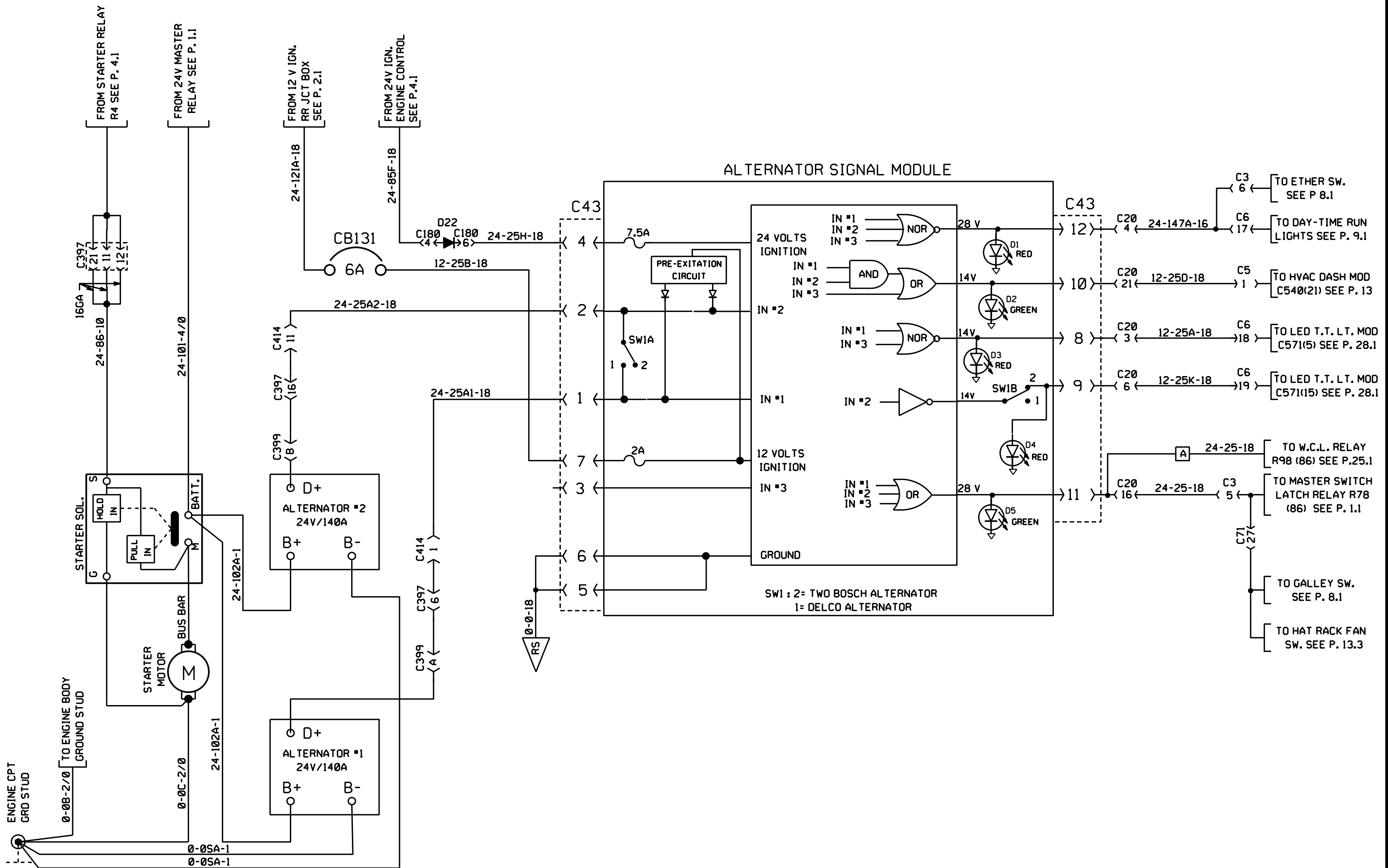

STARTER & BOSCH ALTERNATOR



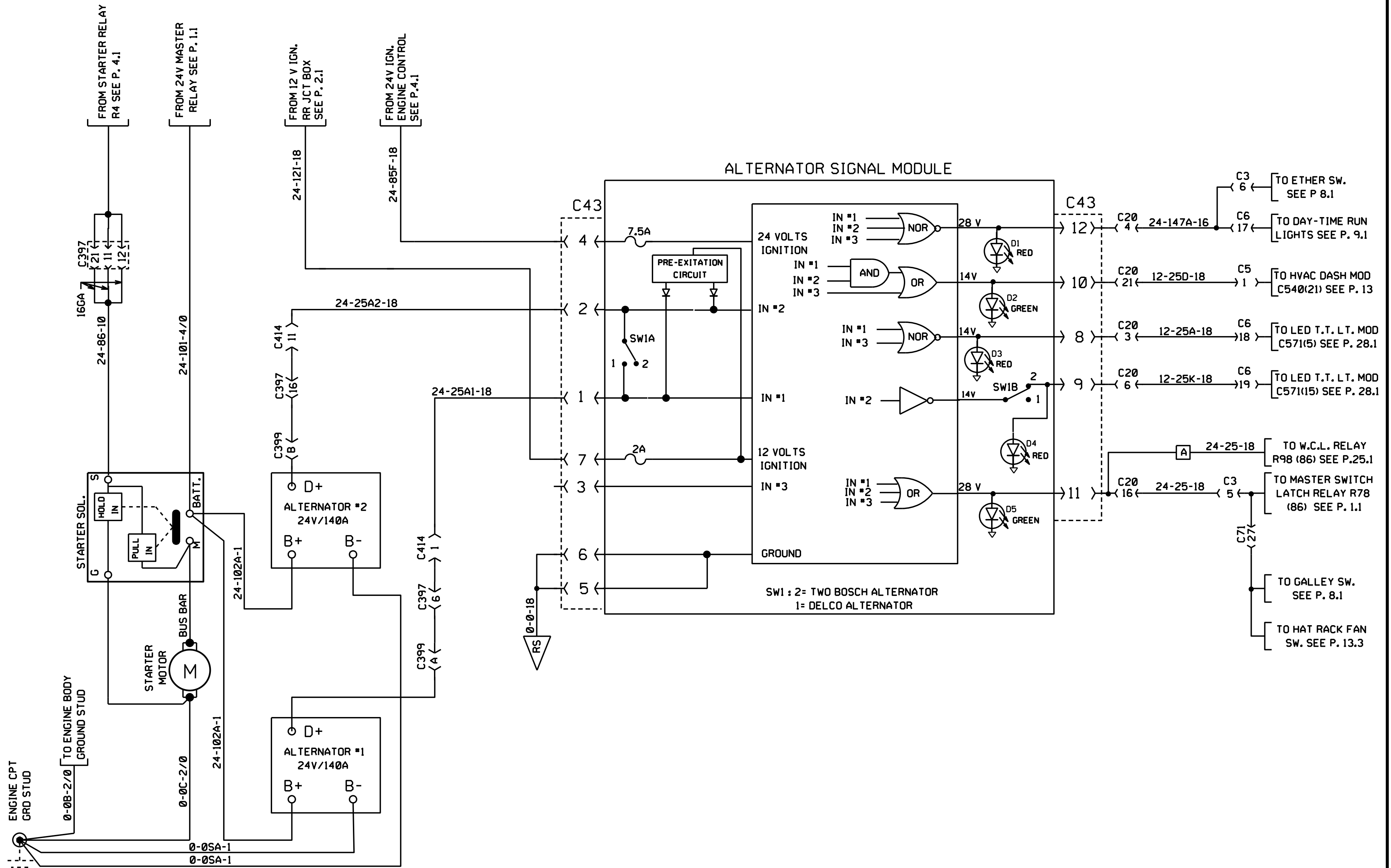

STARTER & BOSCH ALTERNATOR

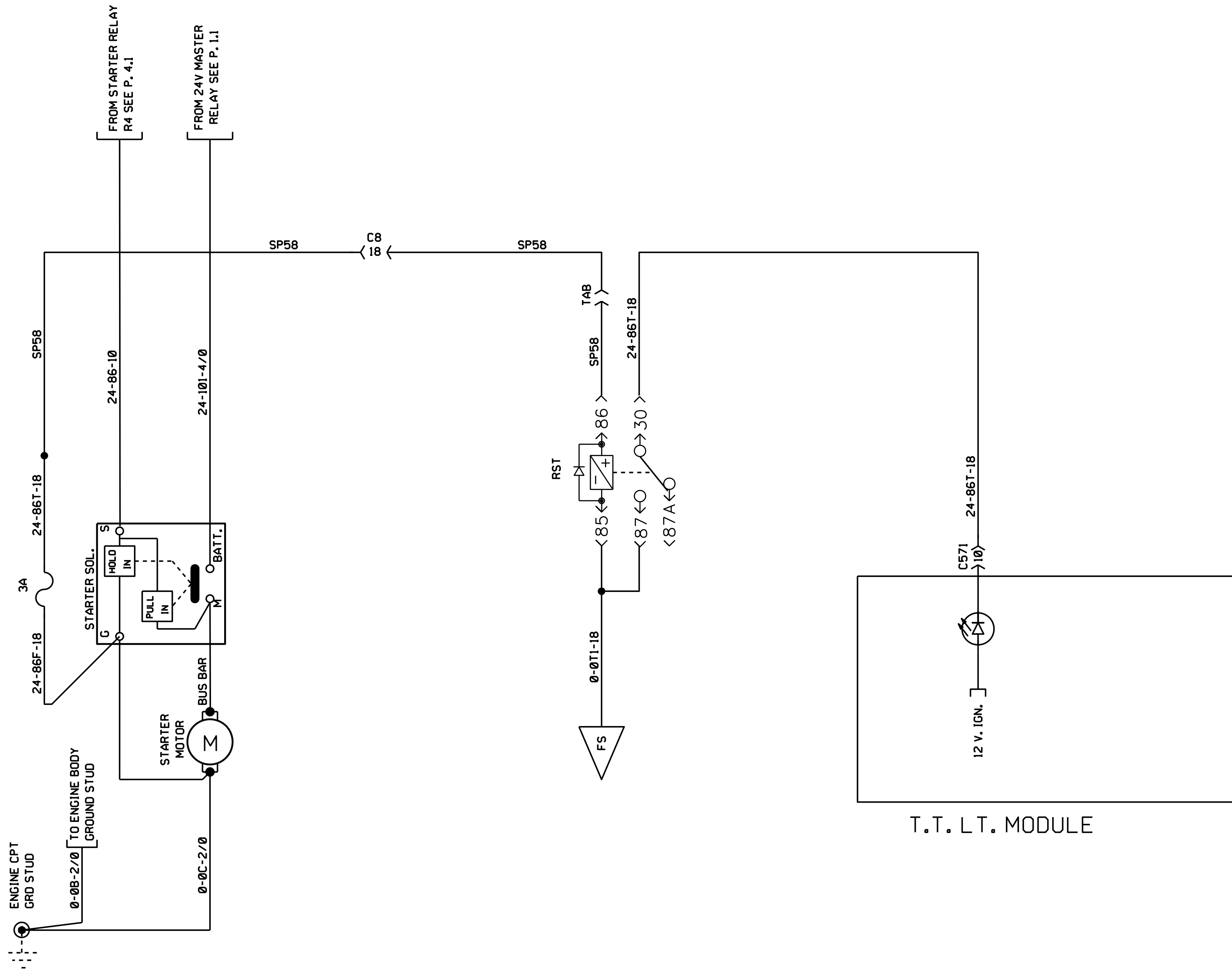

RETROFIT TELL-TALE STARTER ON

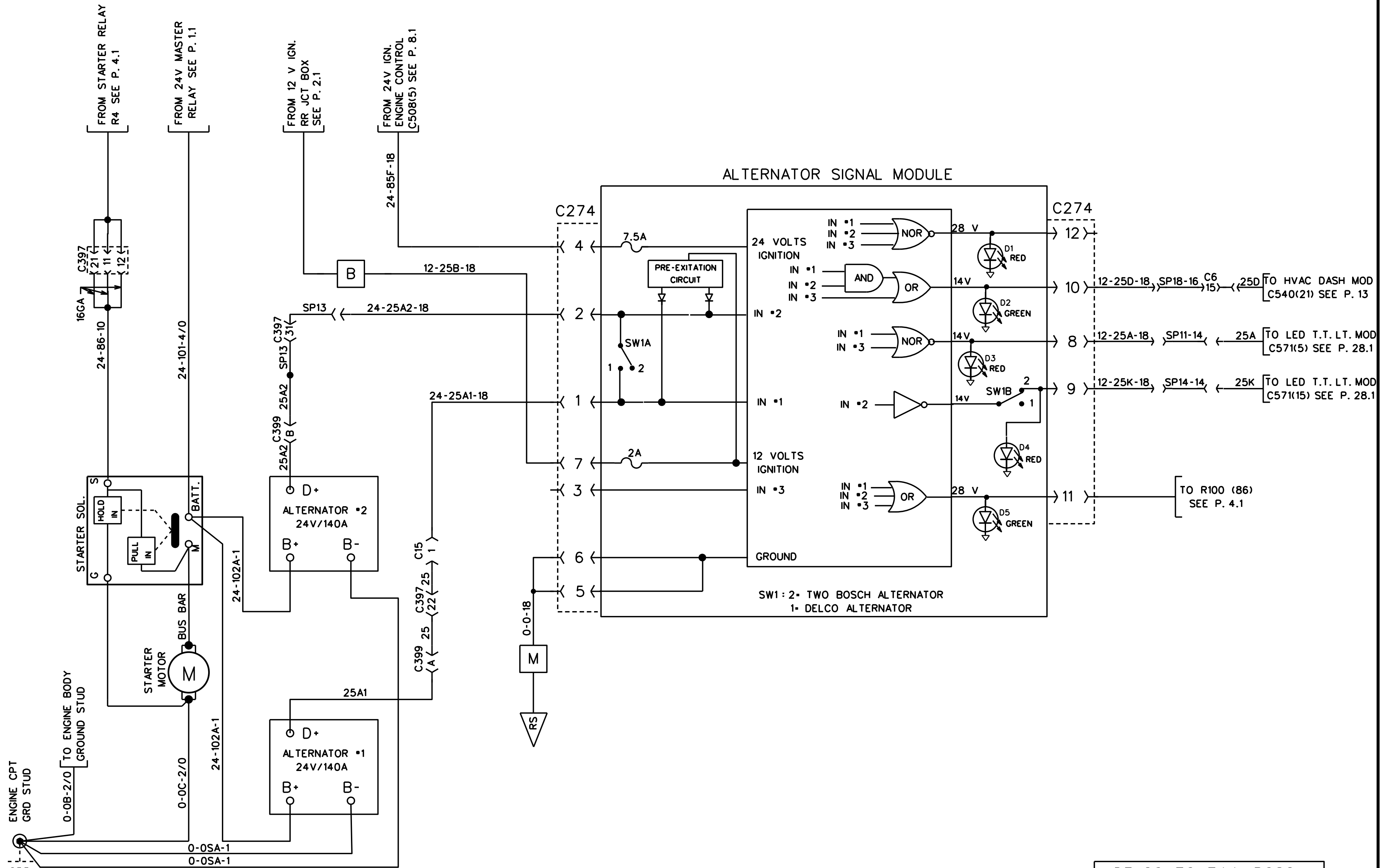

# STARTER & BOSCH ALTERNATOR

DELCO TO TWIN BOSCH  
ALTERNATOR CONVERSION  
W2234, W2285 TO X2901  
EXCEPT X2831

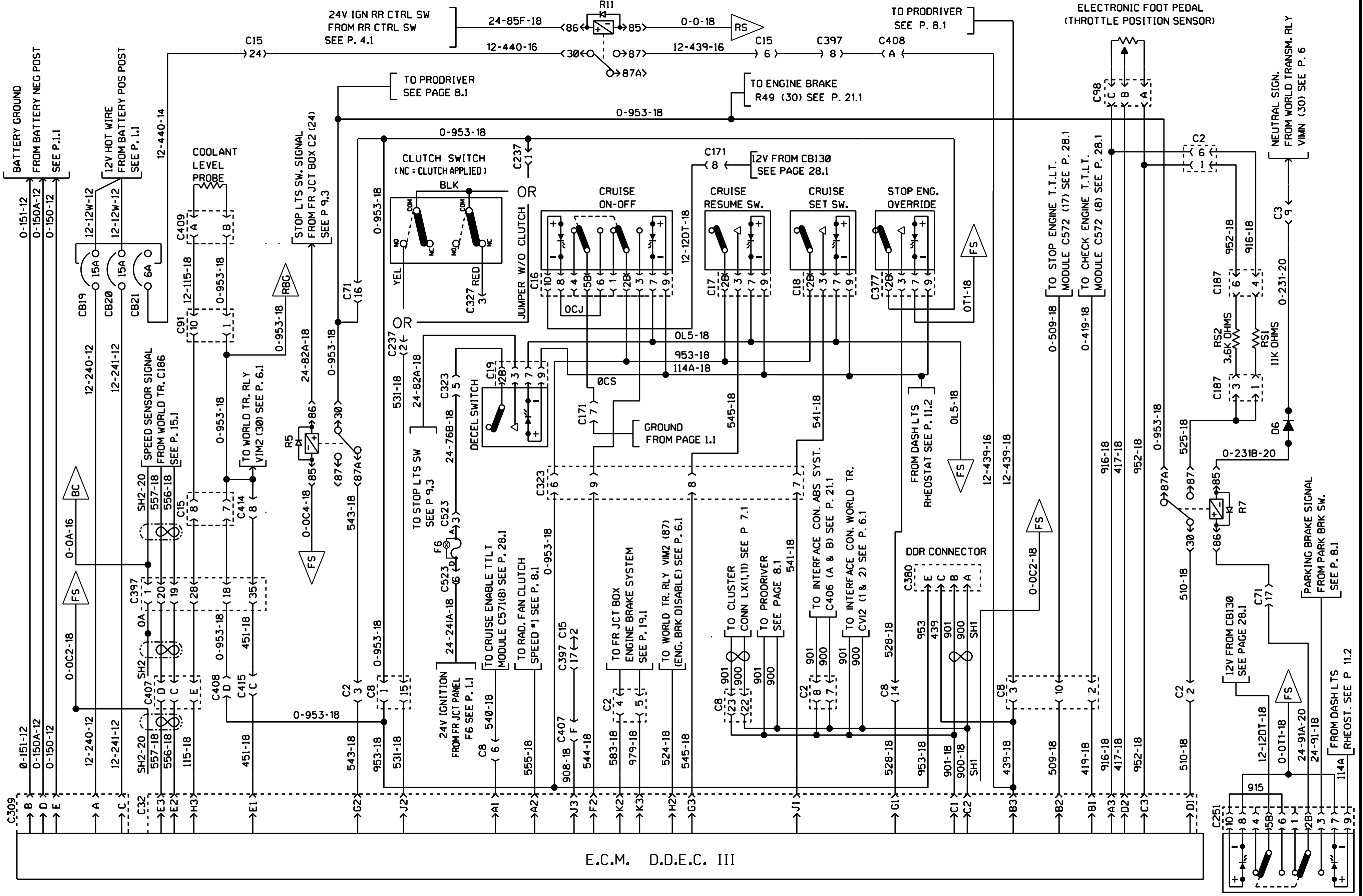

E.C.M. D.D.E.C. III

D.D.E.C. III & IV

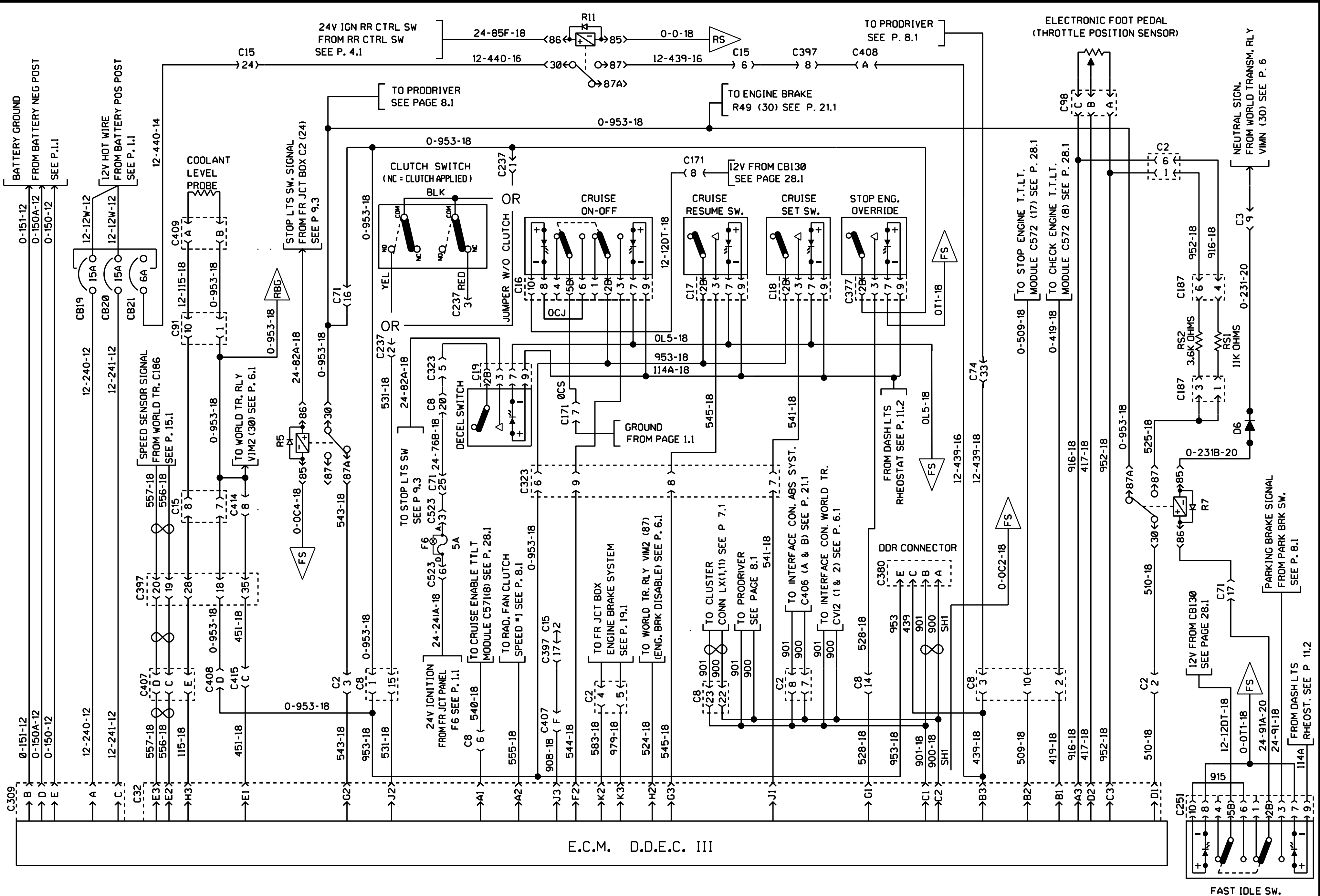

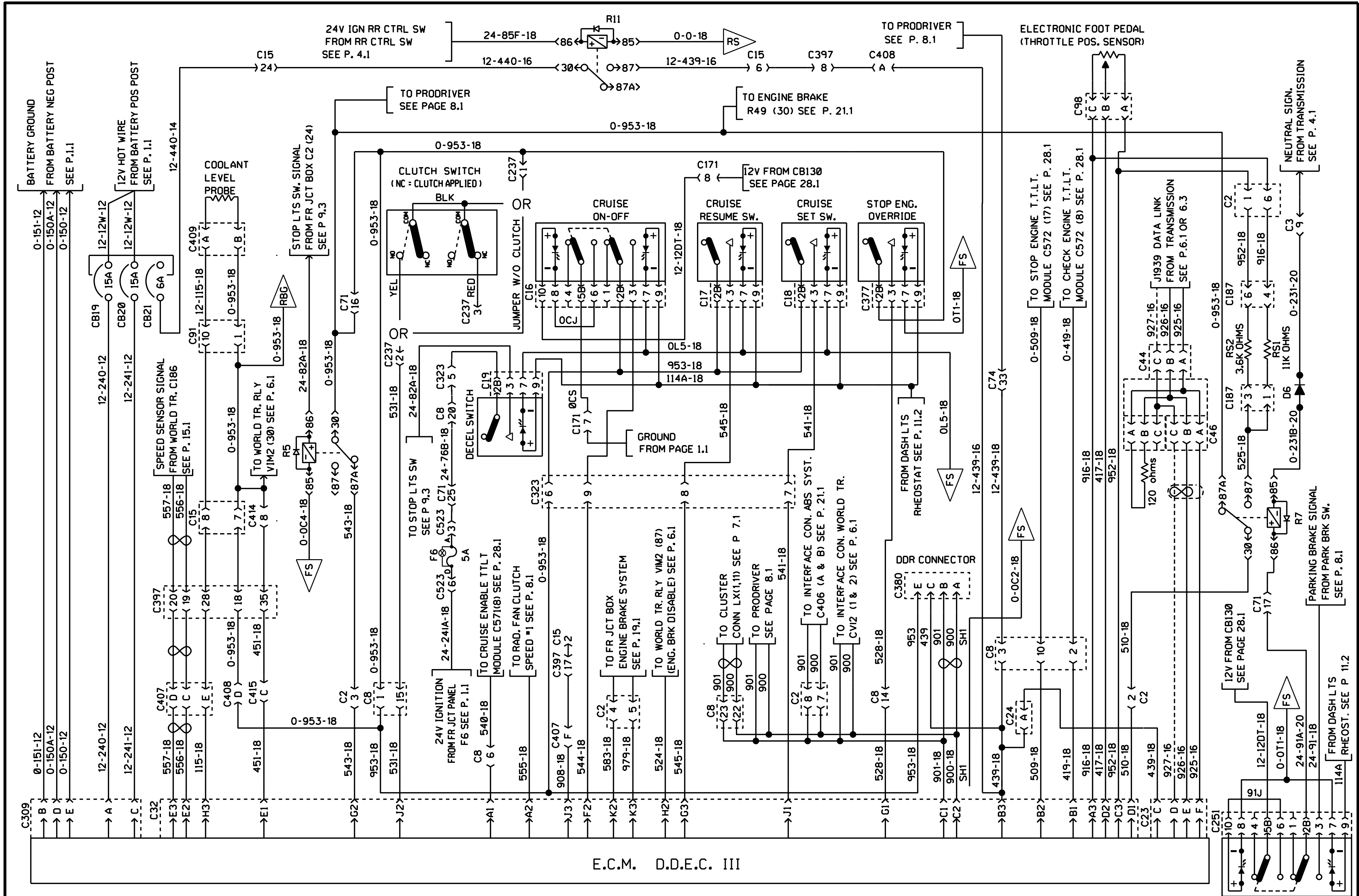

E.C.M. D.D.E.C. III

D.D.E.C. III & IV

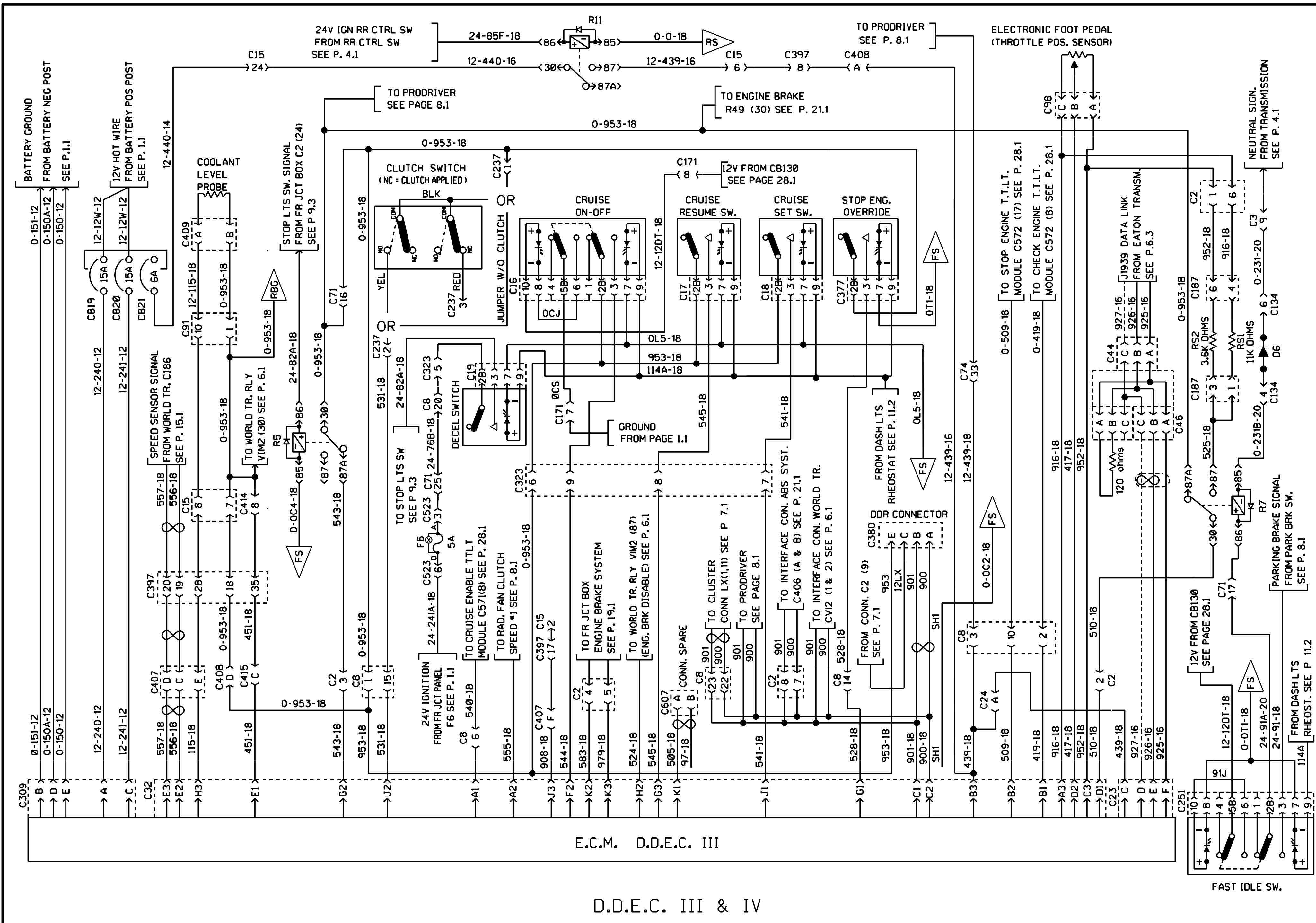



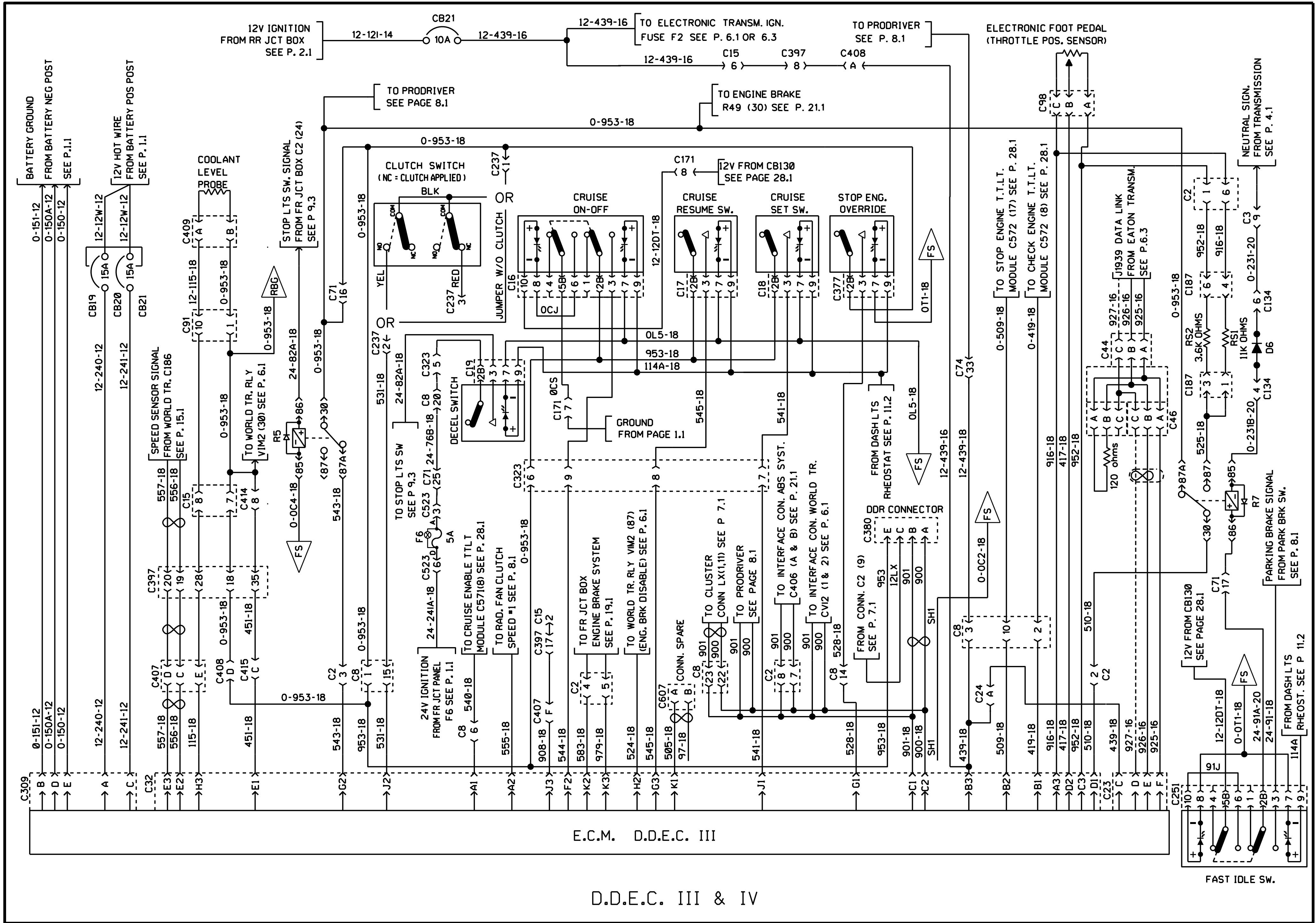

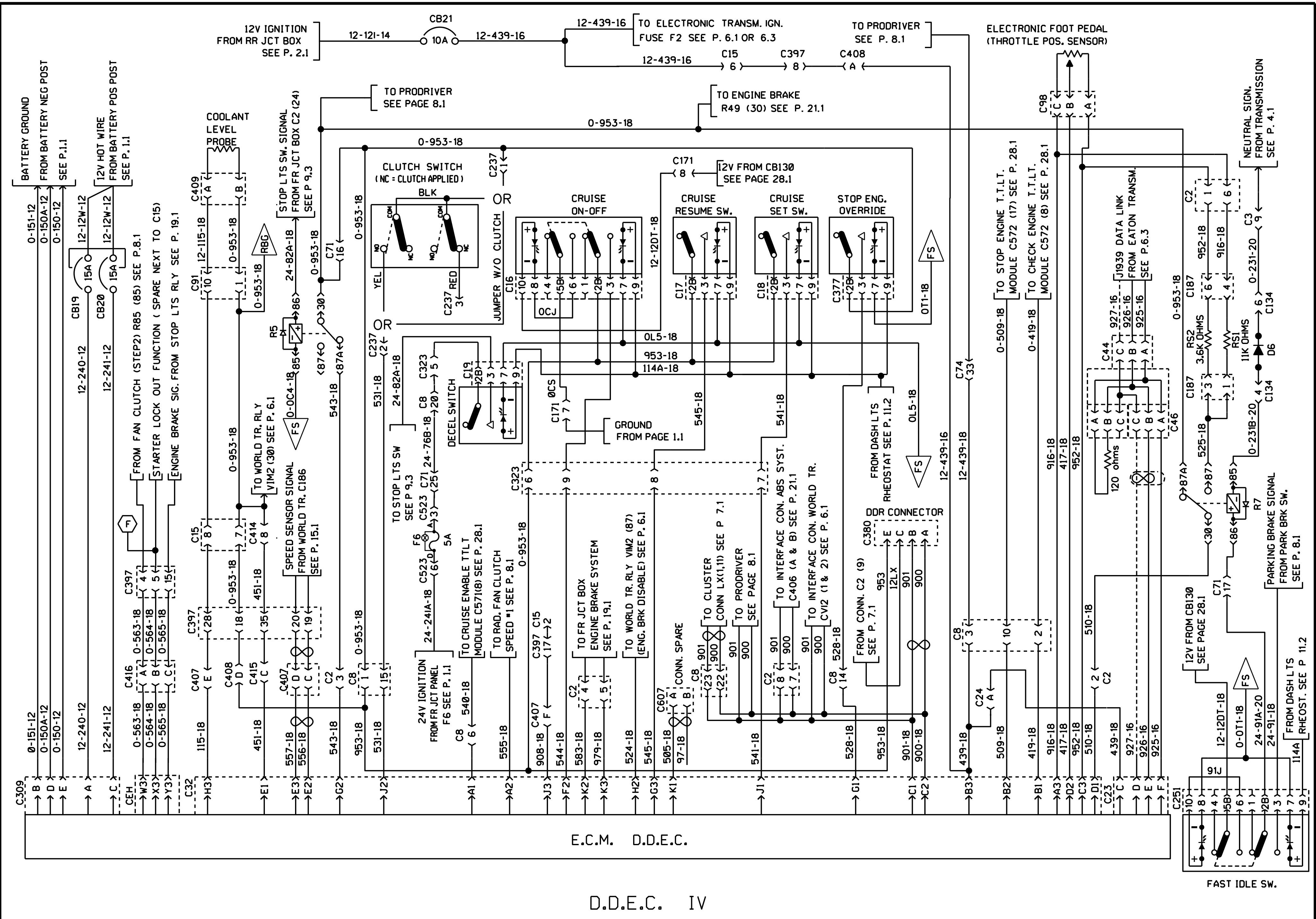

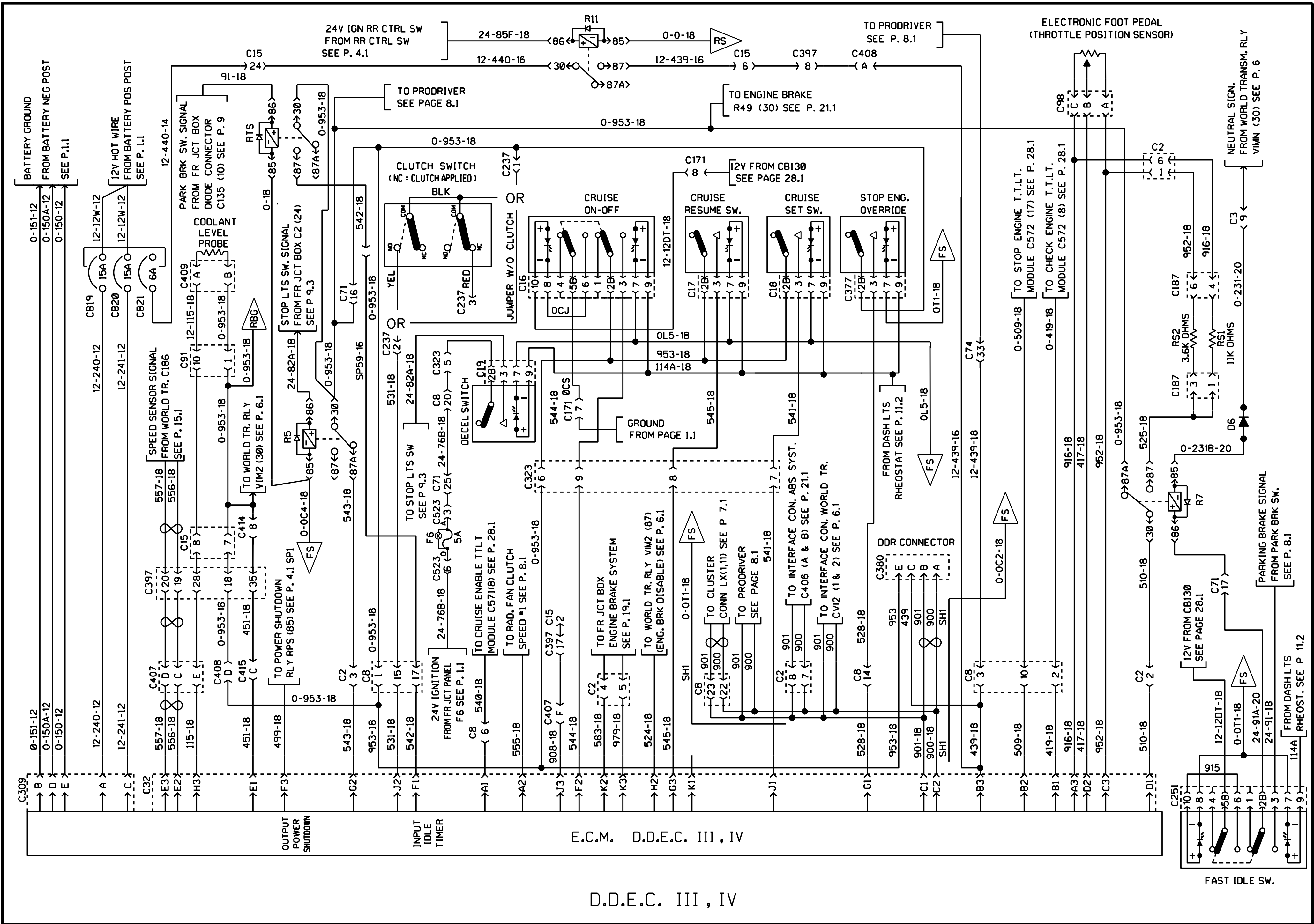

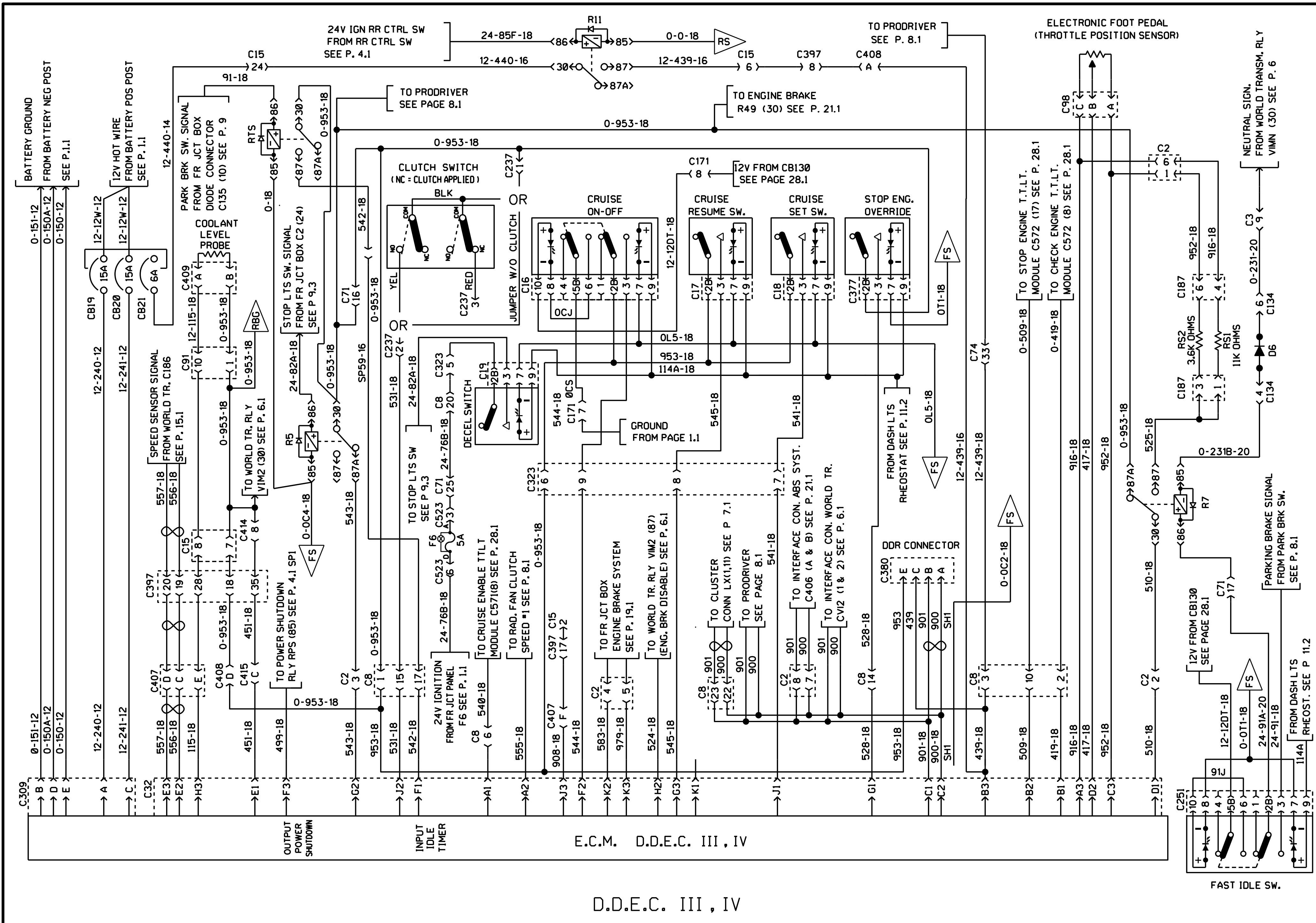

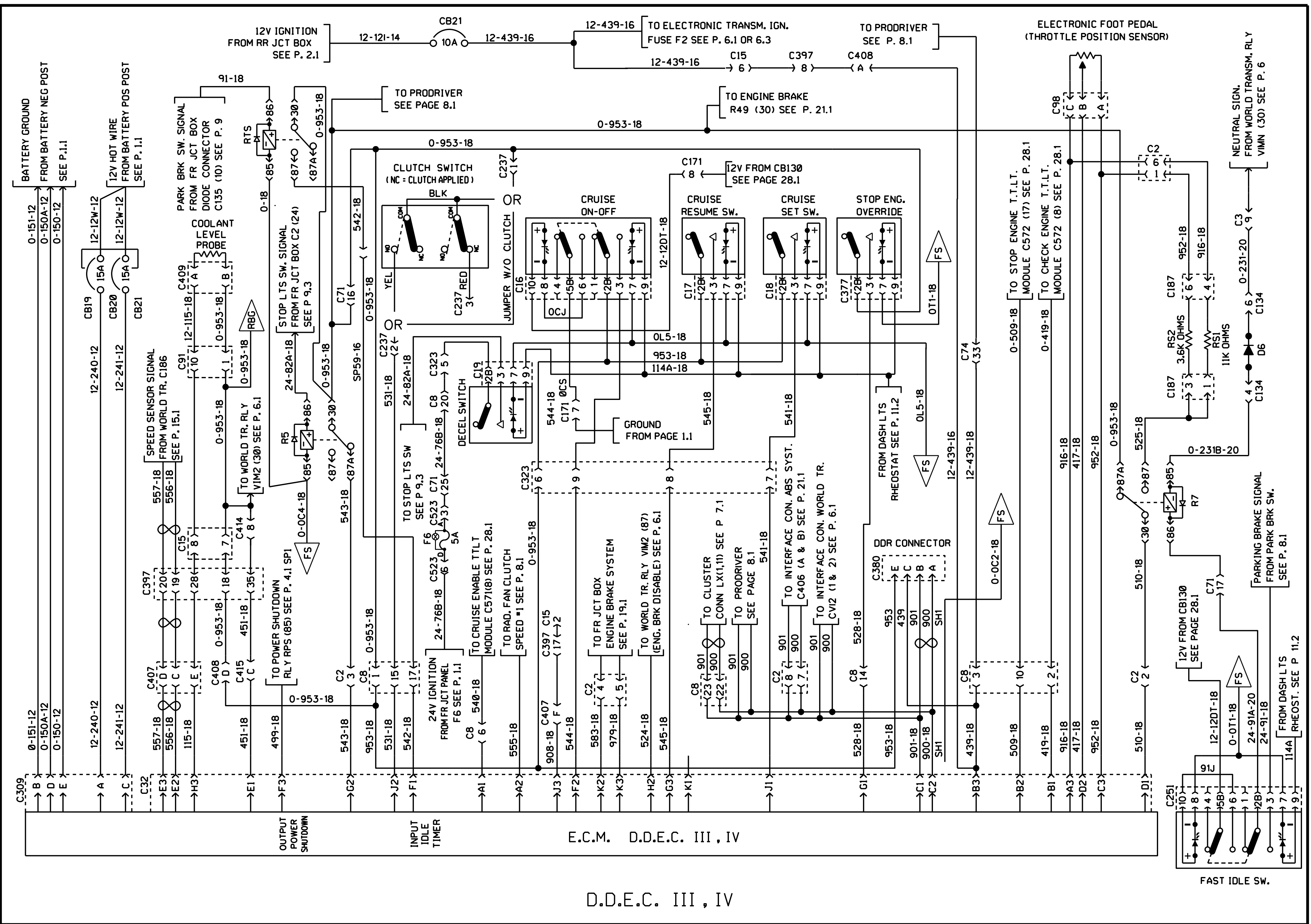

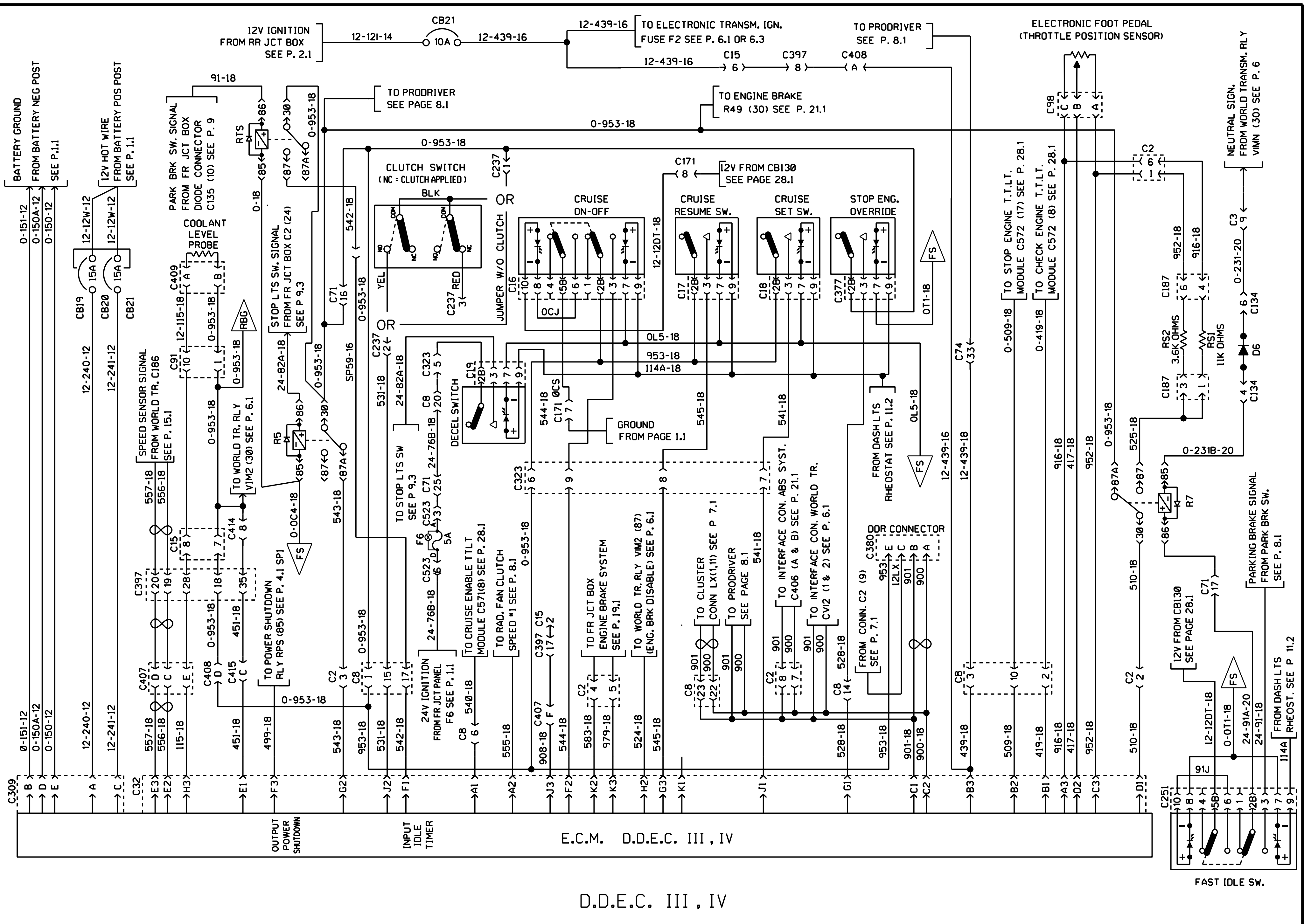



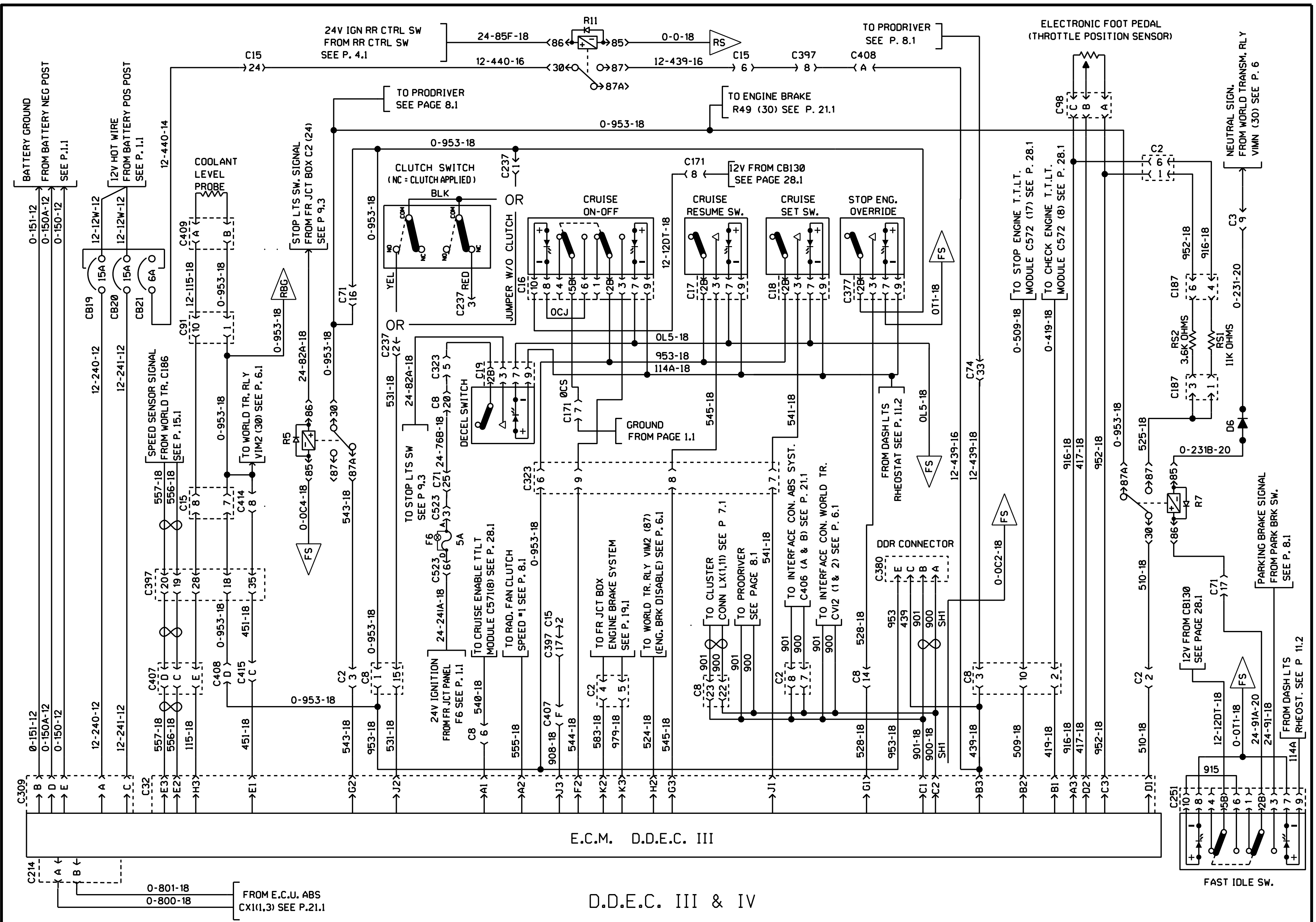



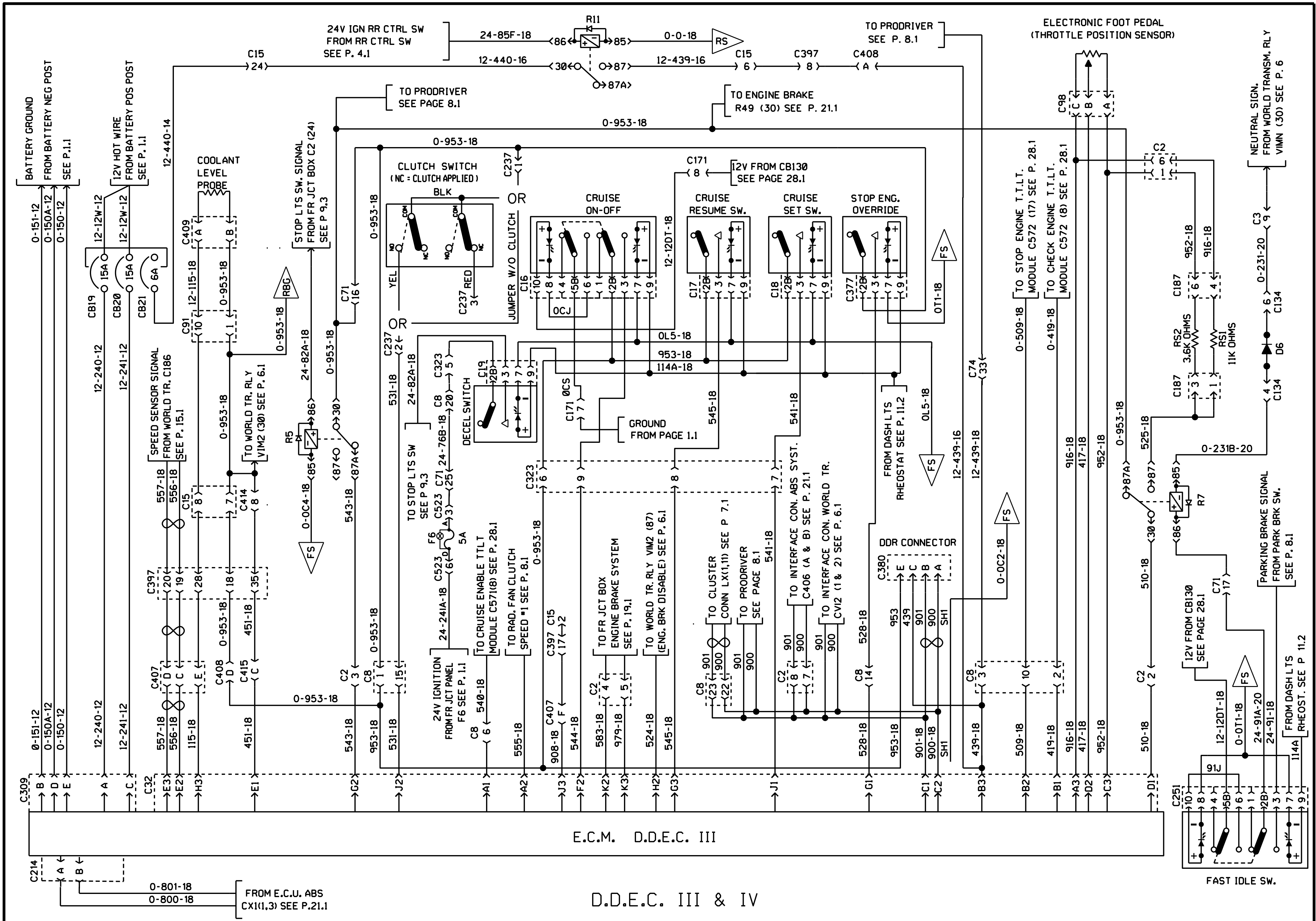

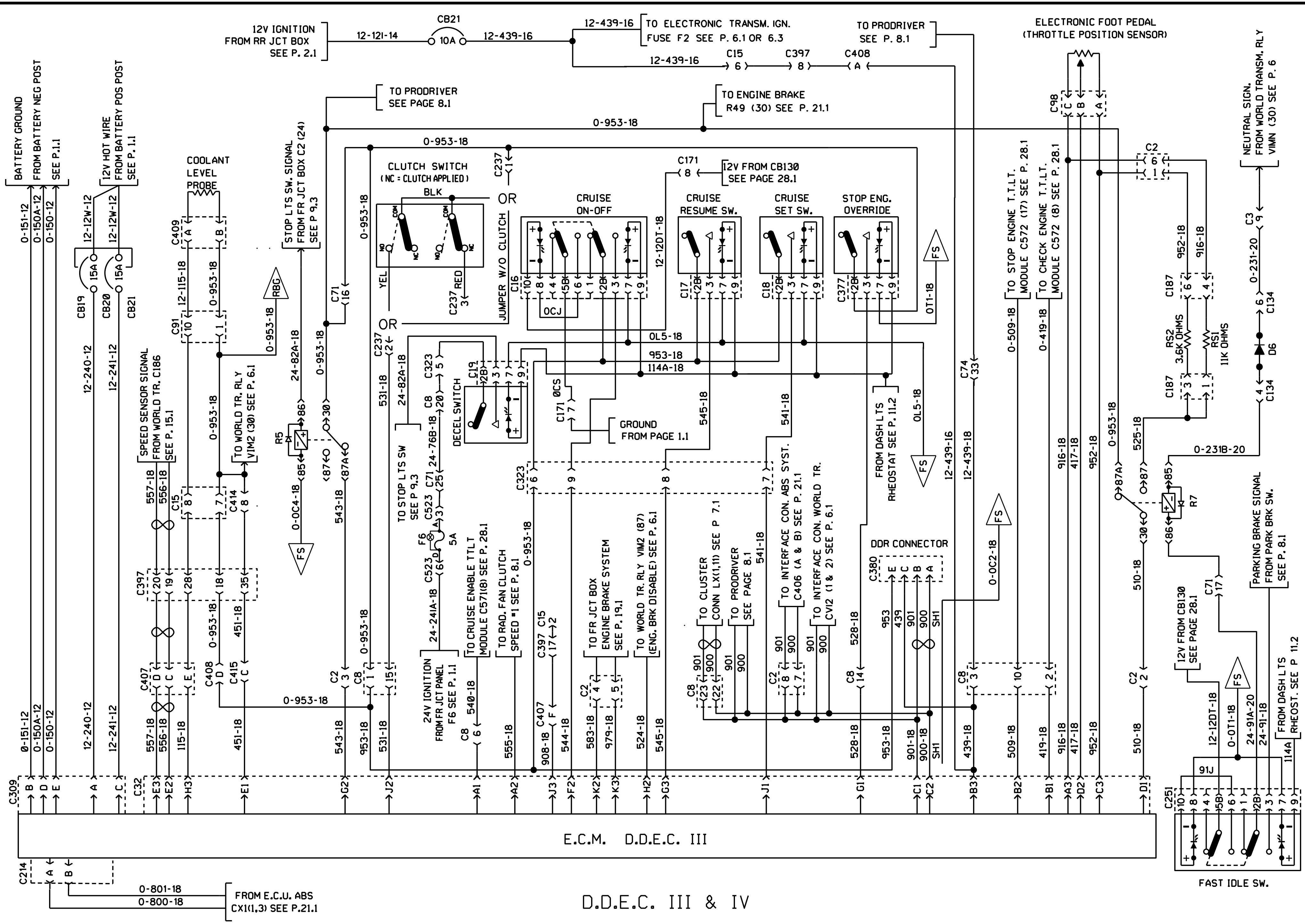

E.C.M. D.D.E.C. III

D.D.E.C. III & IV

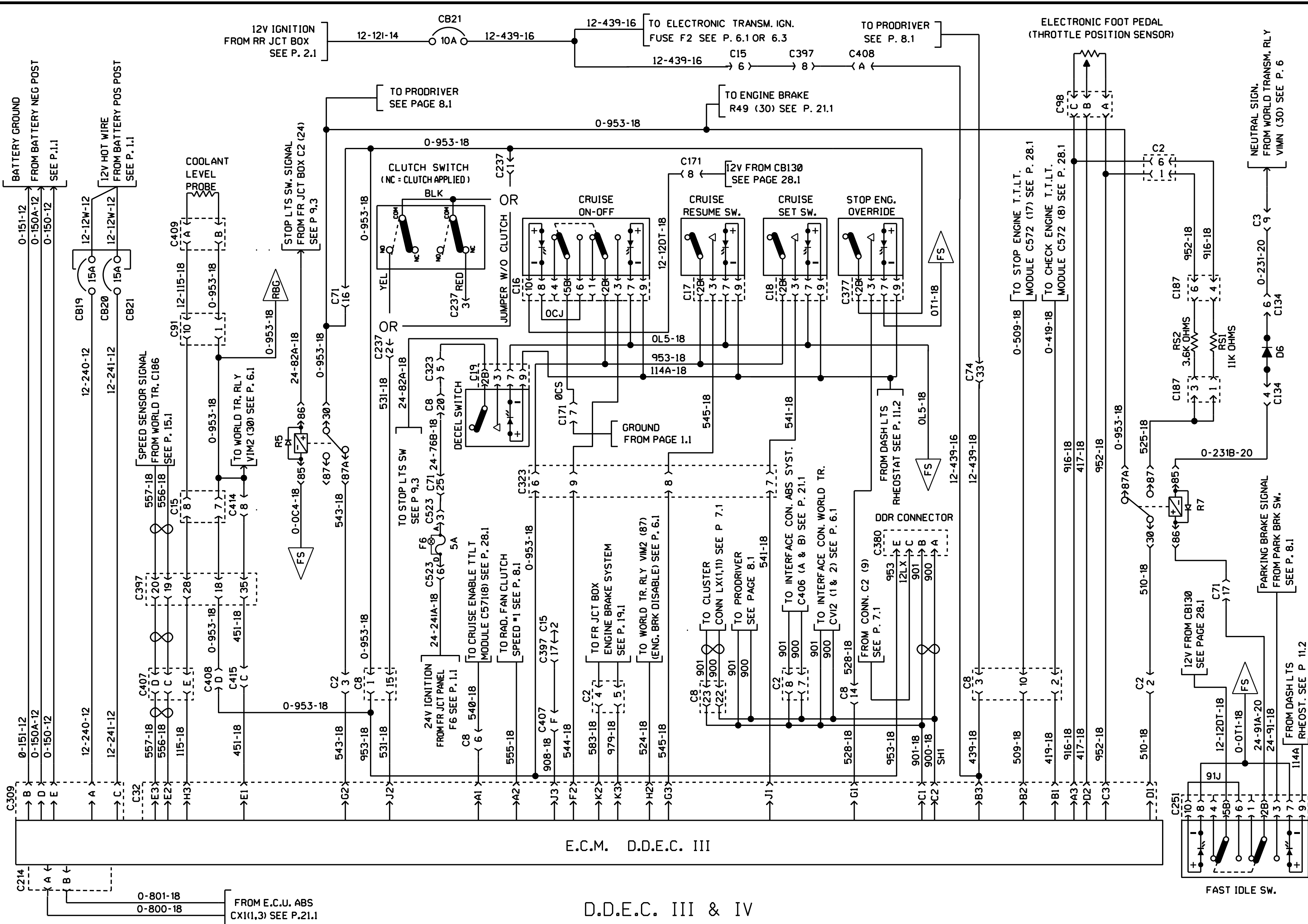

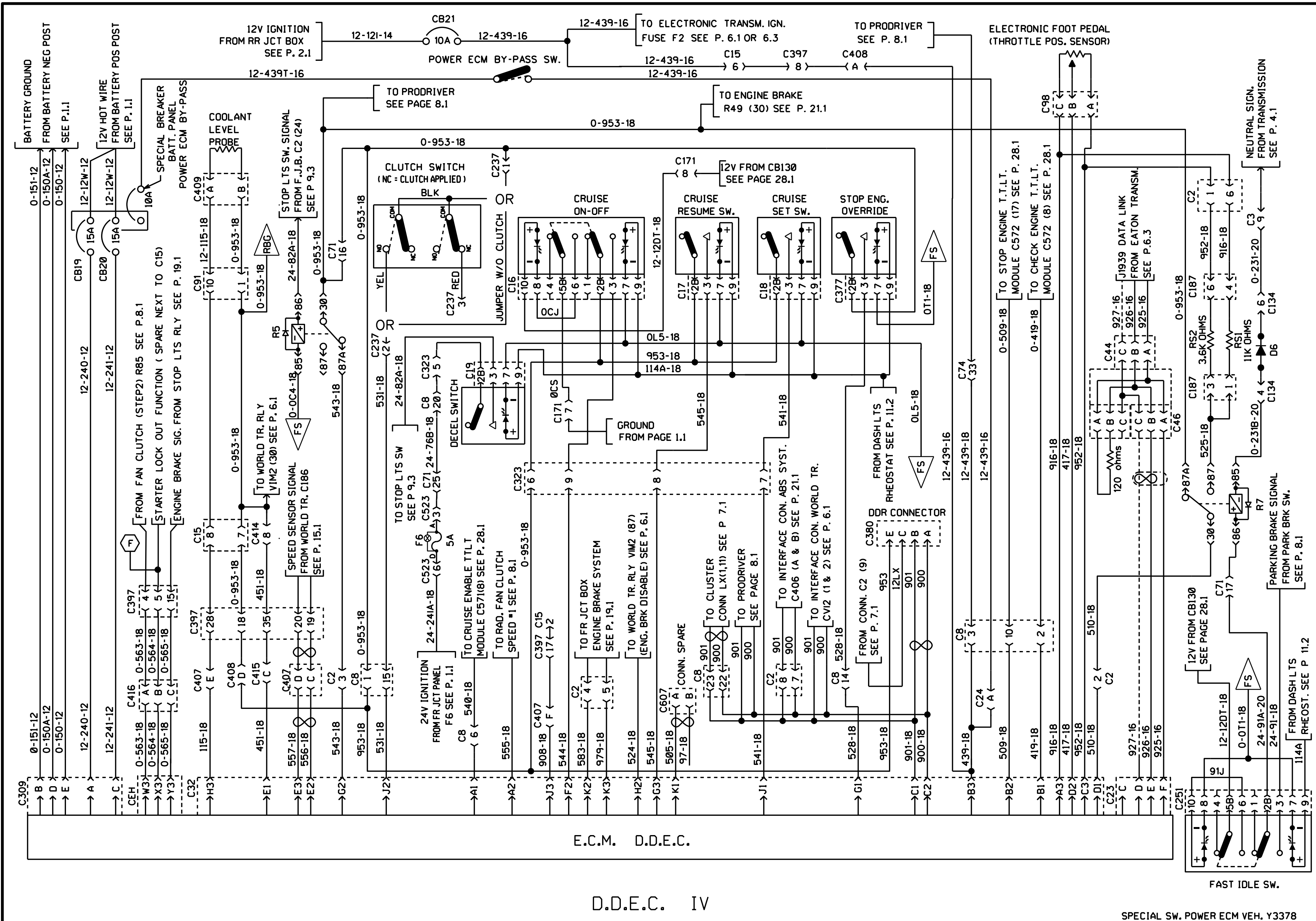

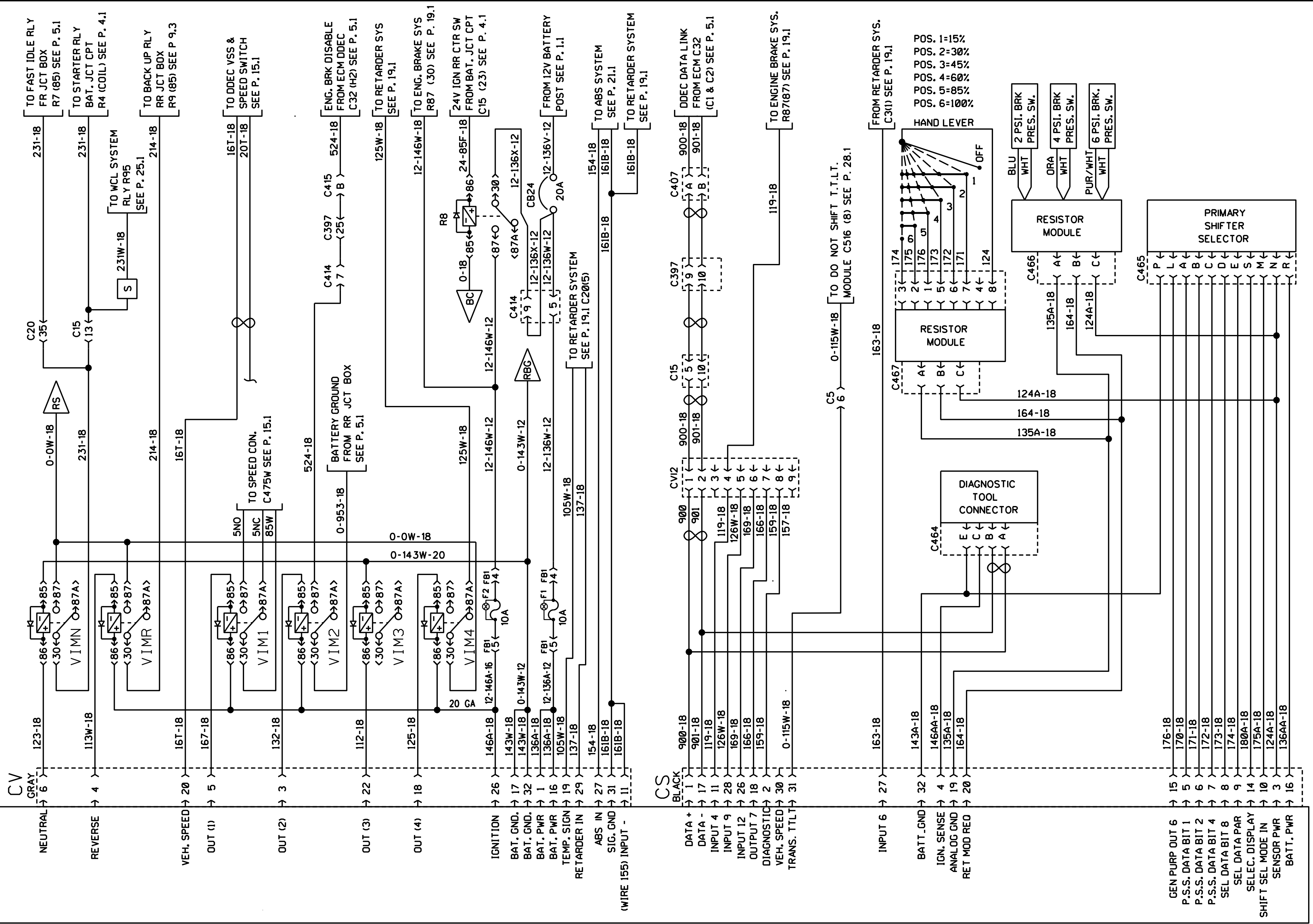

WORLD TRANSMISSION E.C.U.

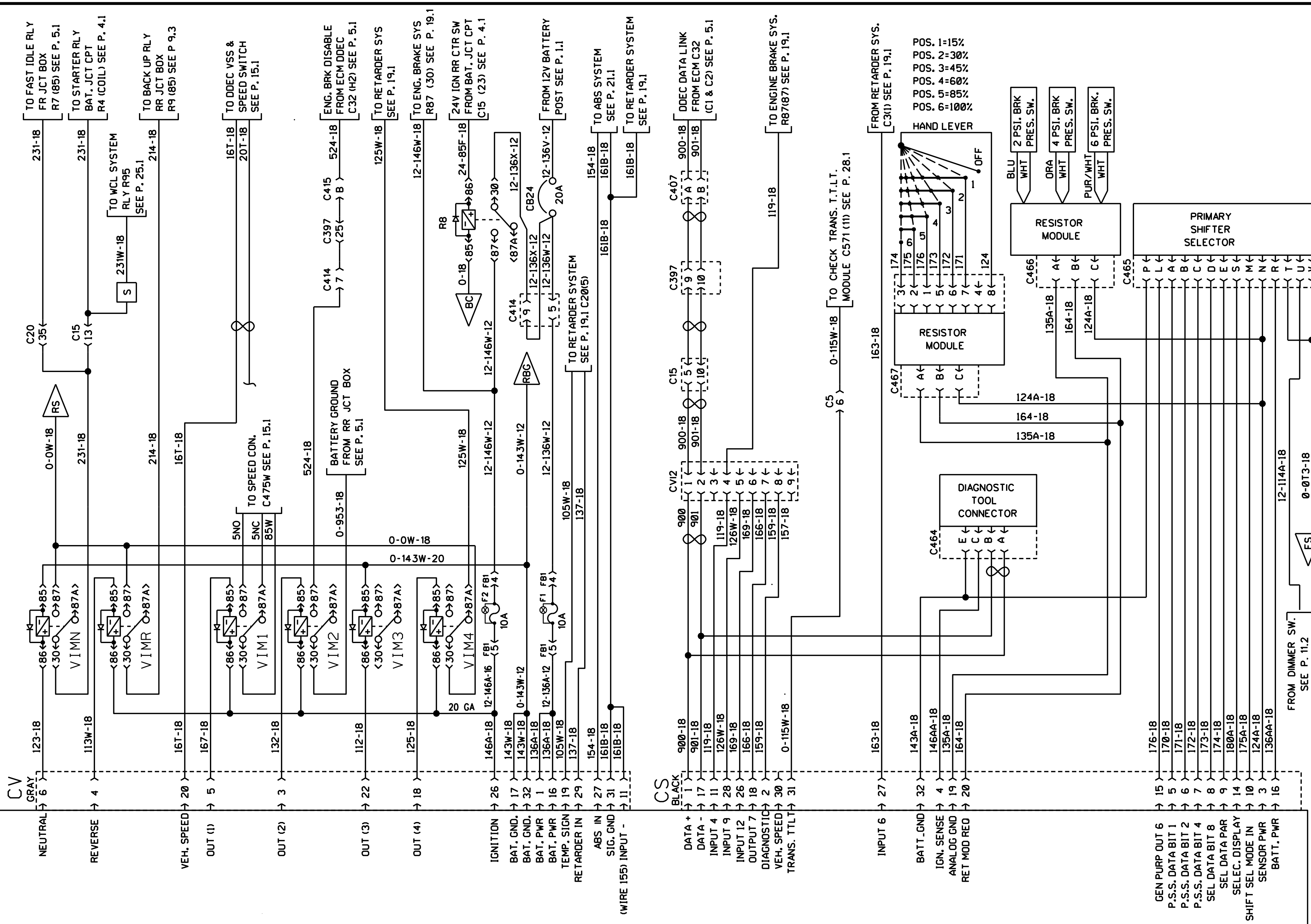

WORLD TRANSMISSION E.C.U.



WORLD TRANSMISSION E.C.U.

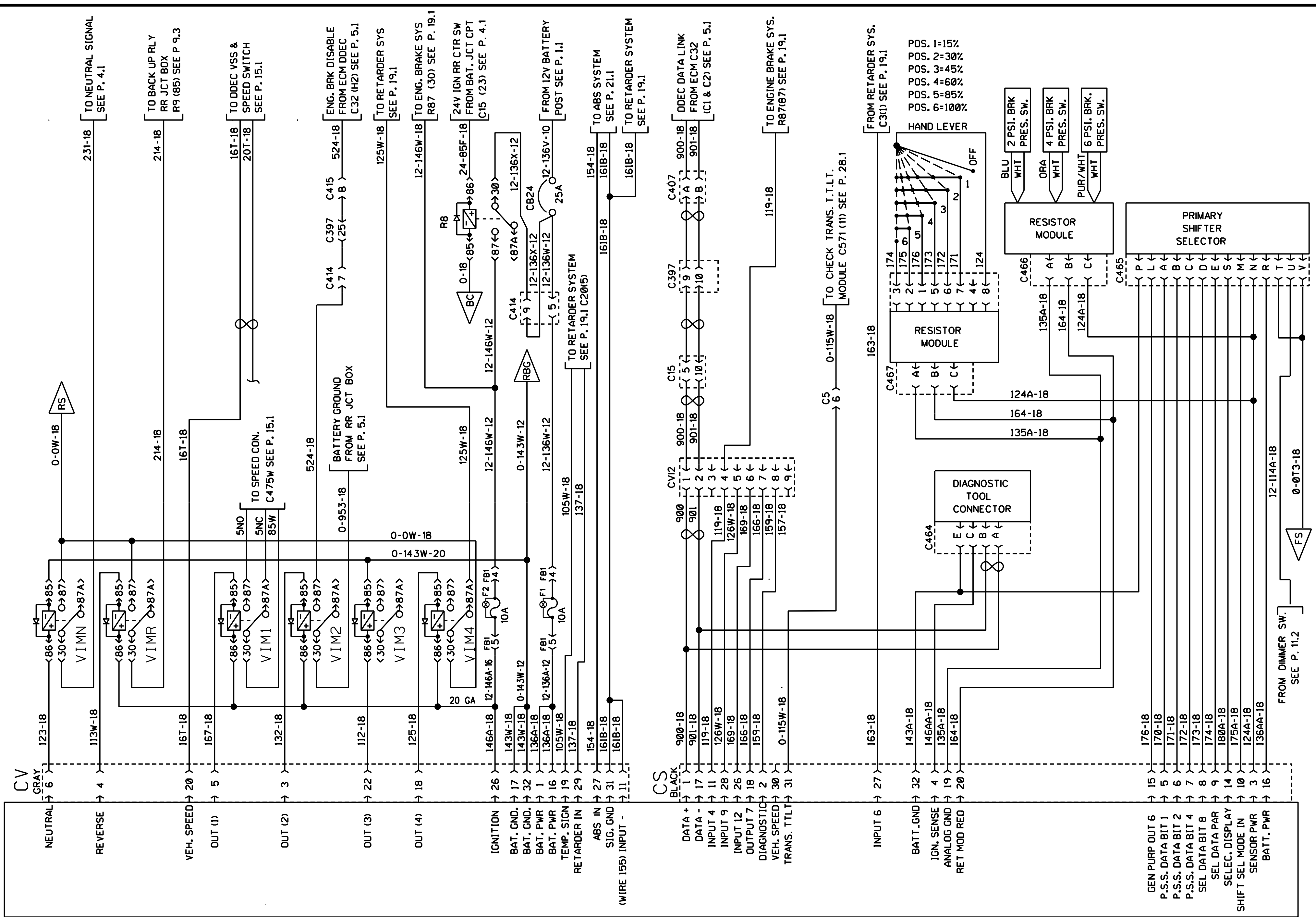



CV

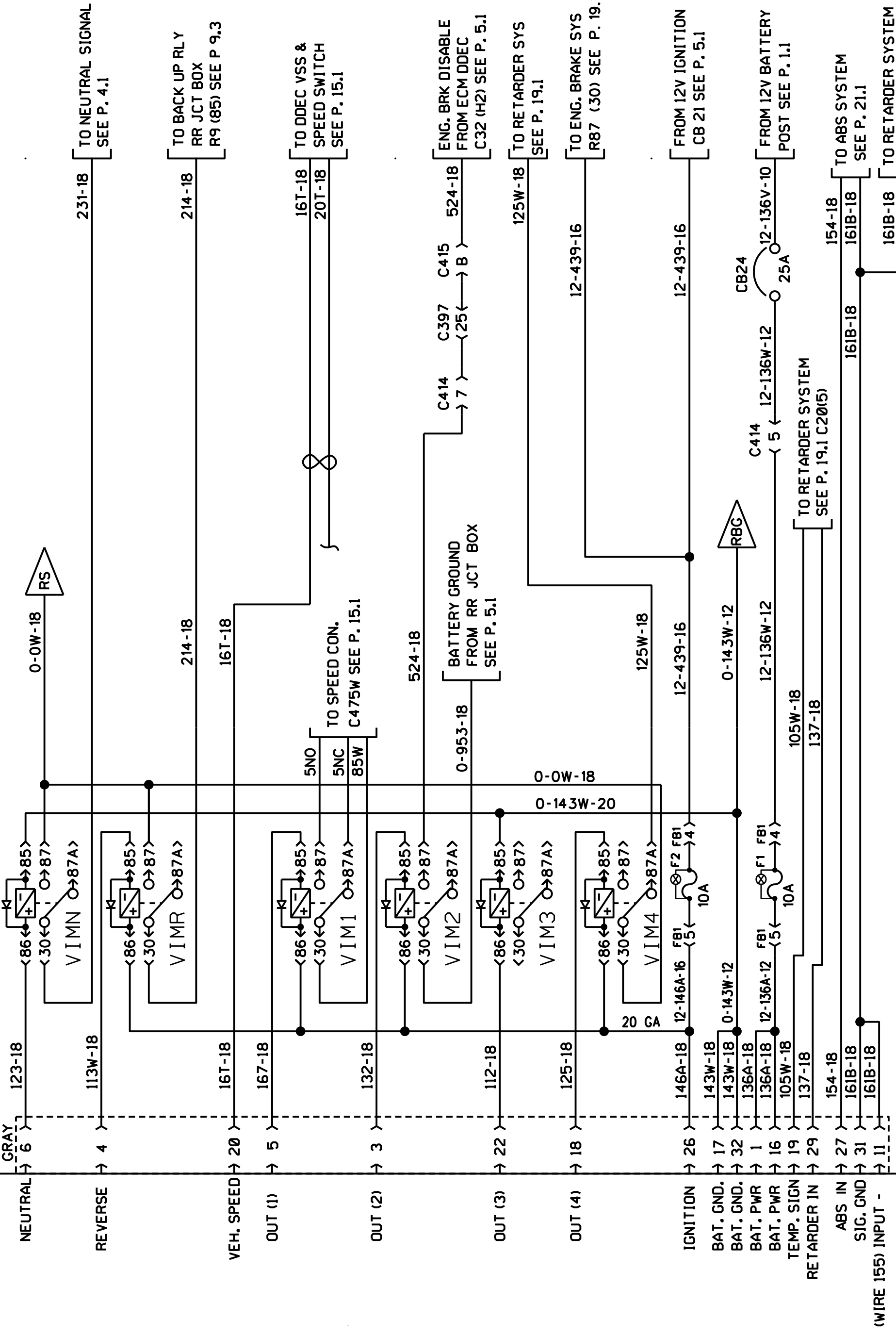

CS

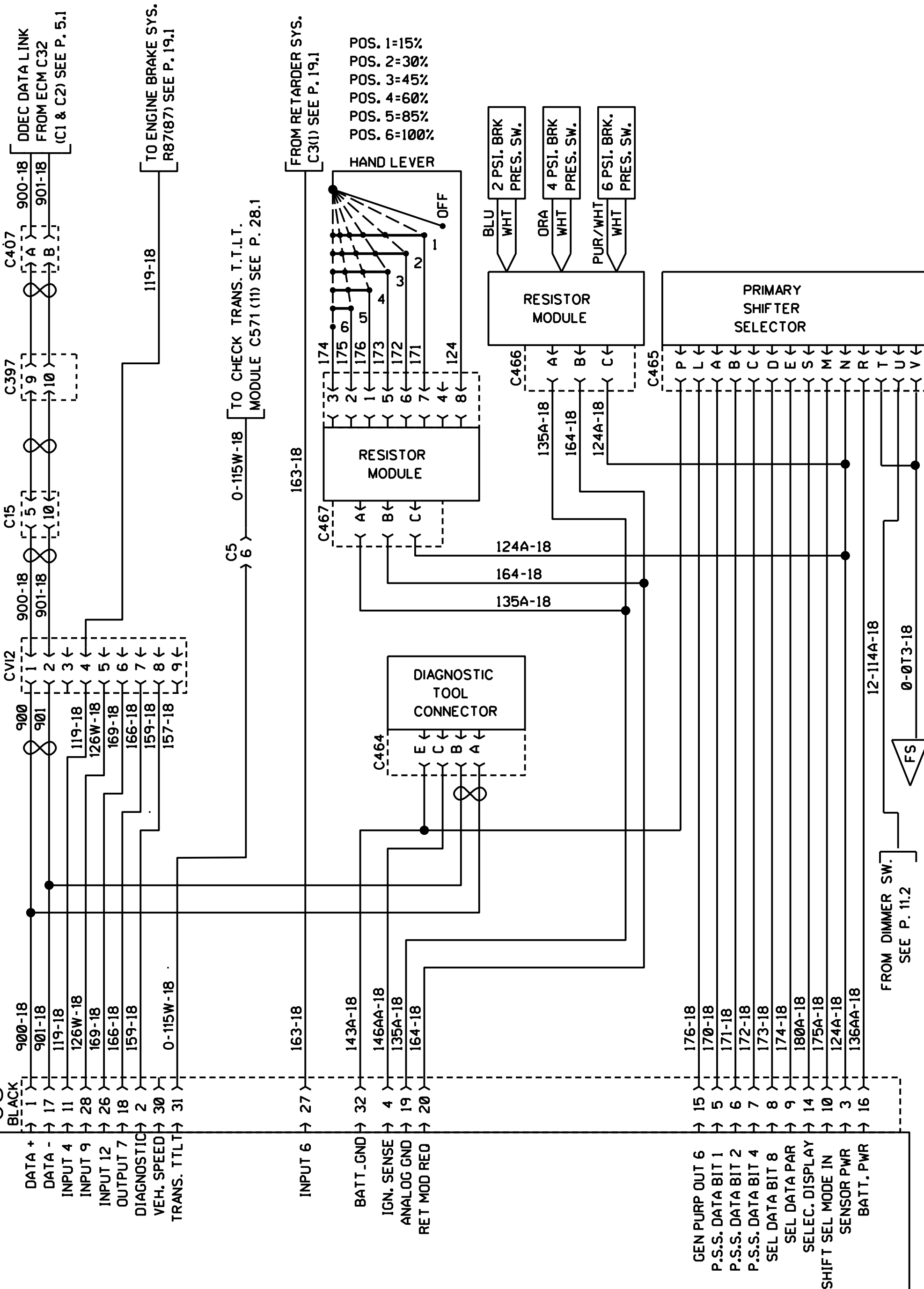

WORLD TRANSMISSION E.C.U.

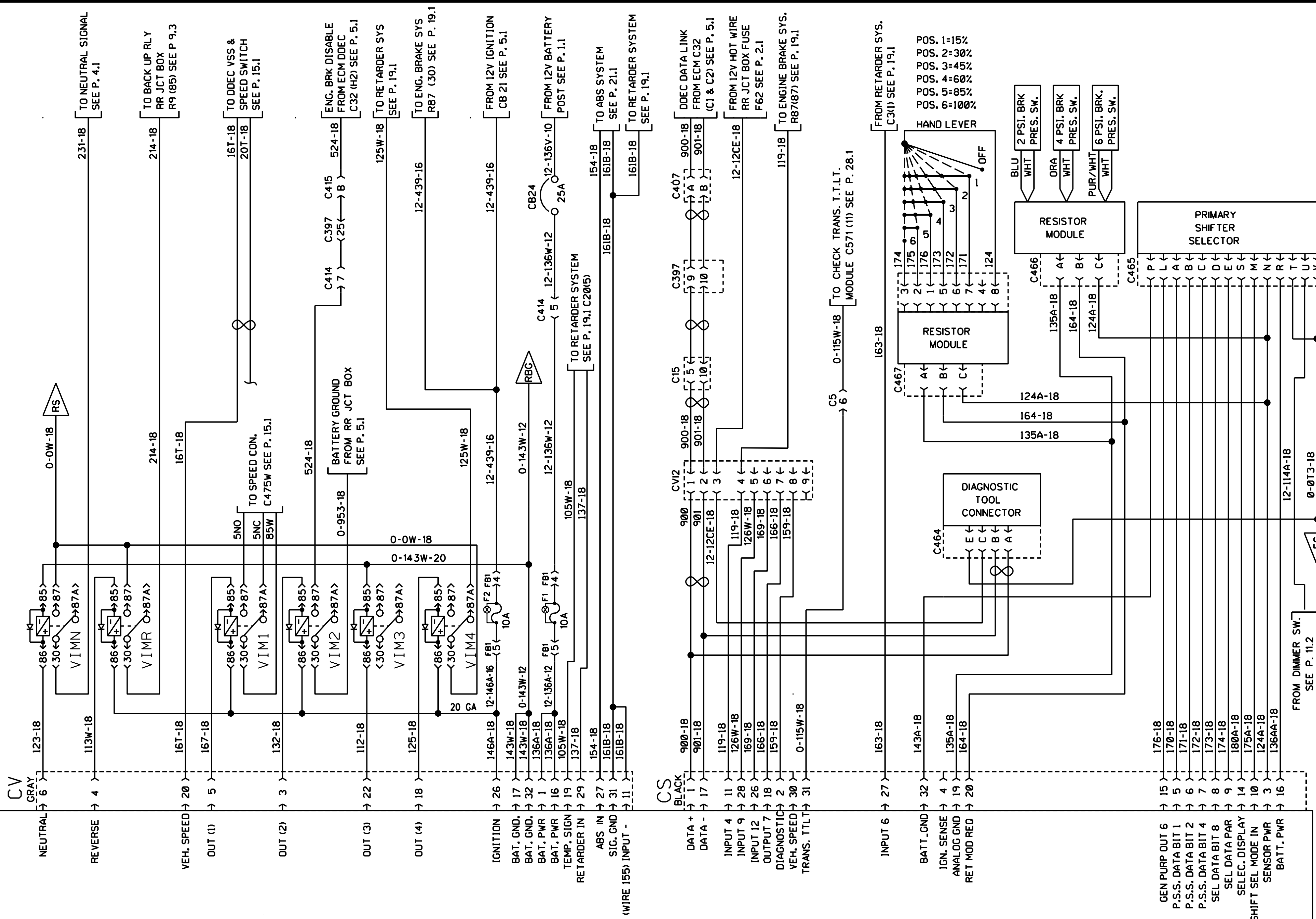

WORLD TRANSMISSION E.C.U.

WORLD TRANSMISSION E.C.U.

**PREVOST**

**WIRING DIAGRAM**

NO:

**0060902**

PAGE: **6.1sp1**

REVISION  
00

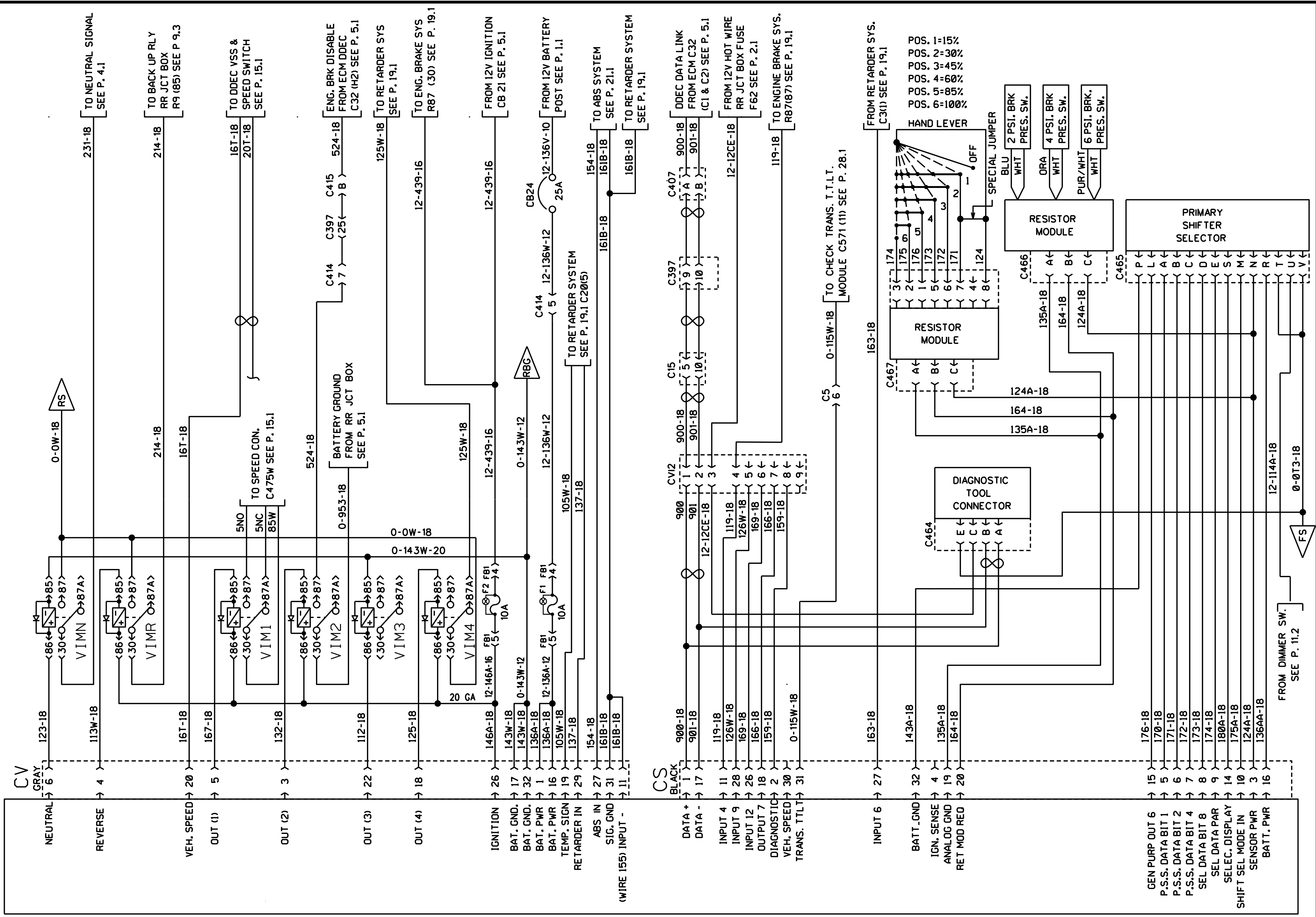

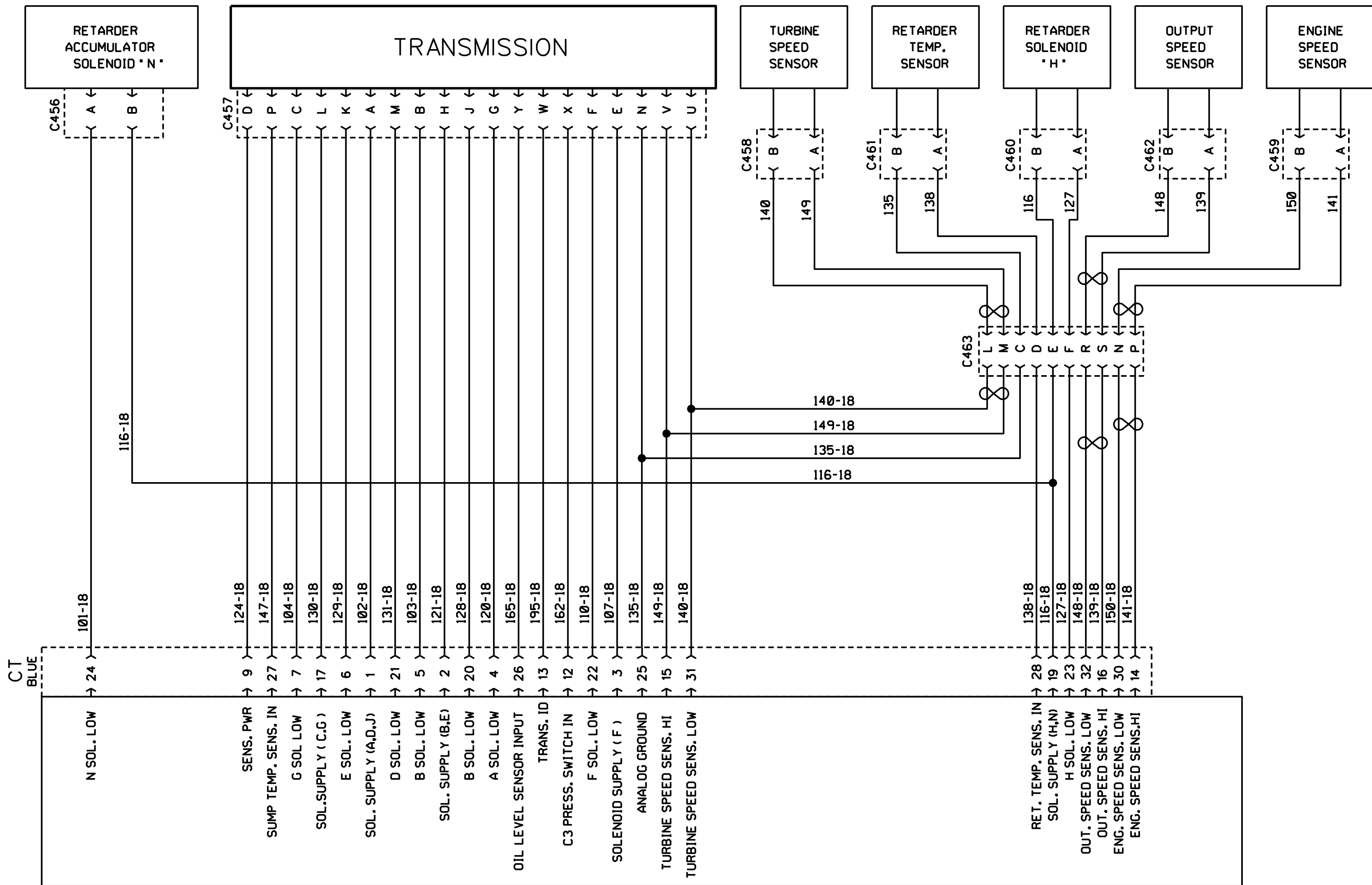

WORLD TRANSMISSION E.C.U. (SUITE)

TRANSMISSION HARNESS

REAR JUNCTION COMPARTMENT

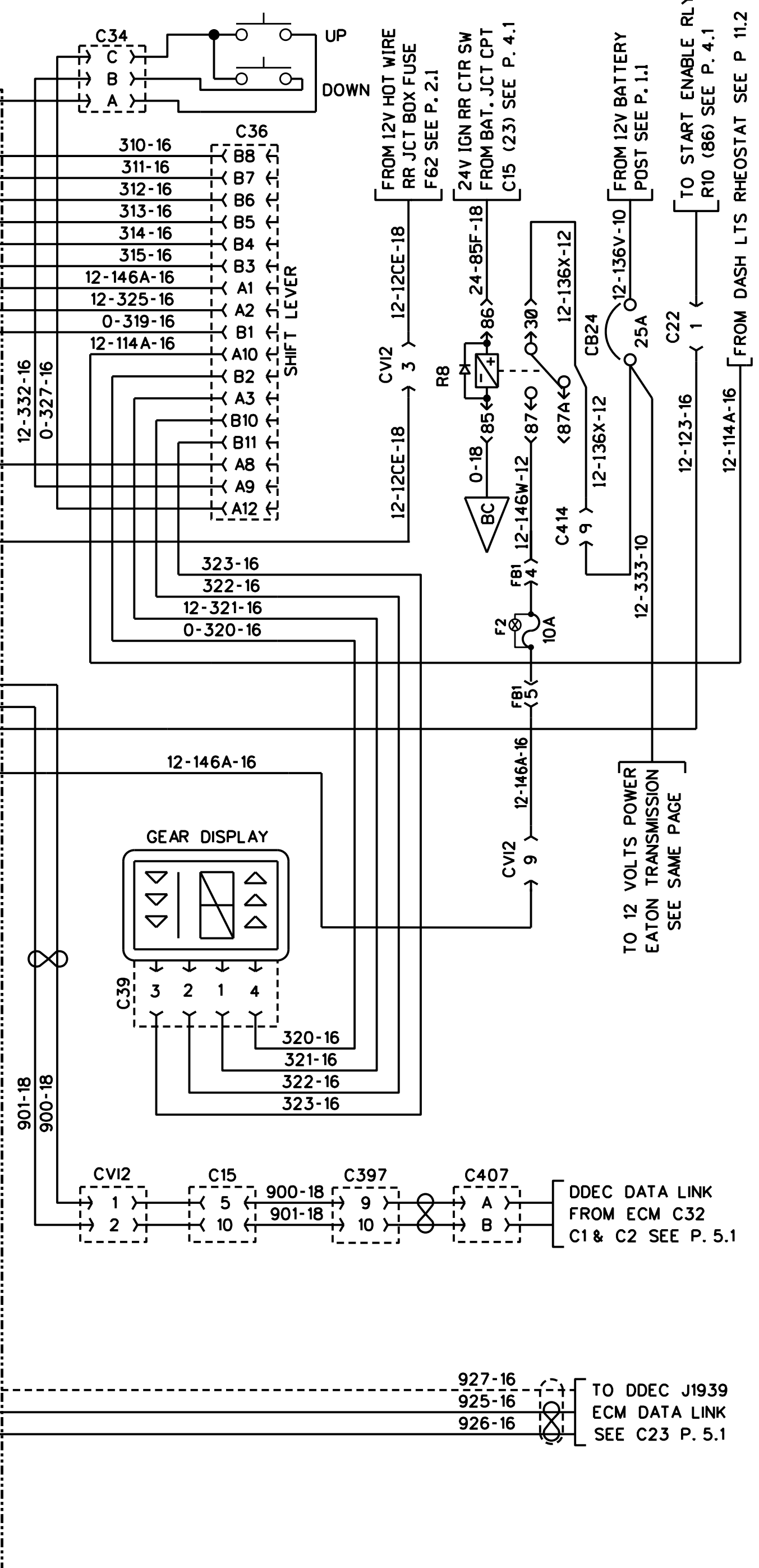
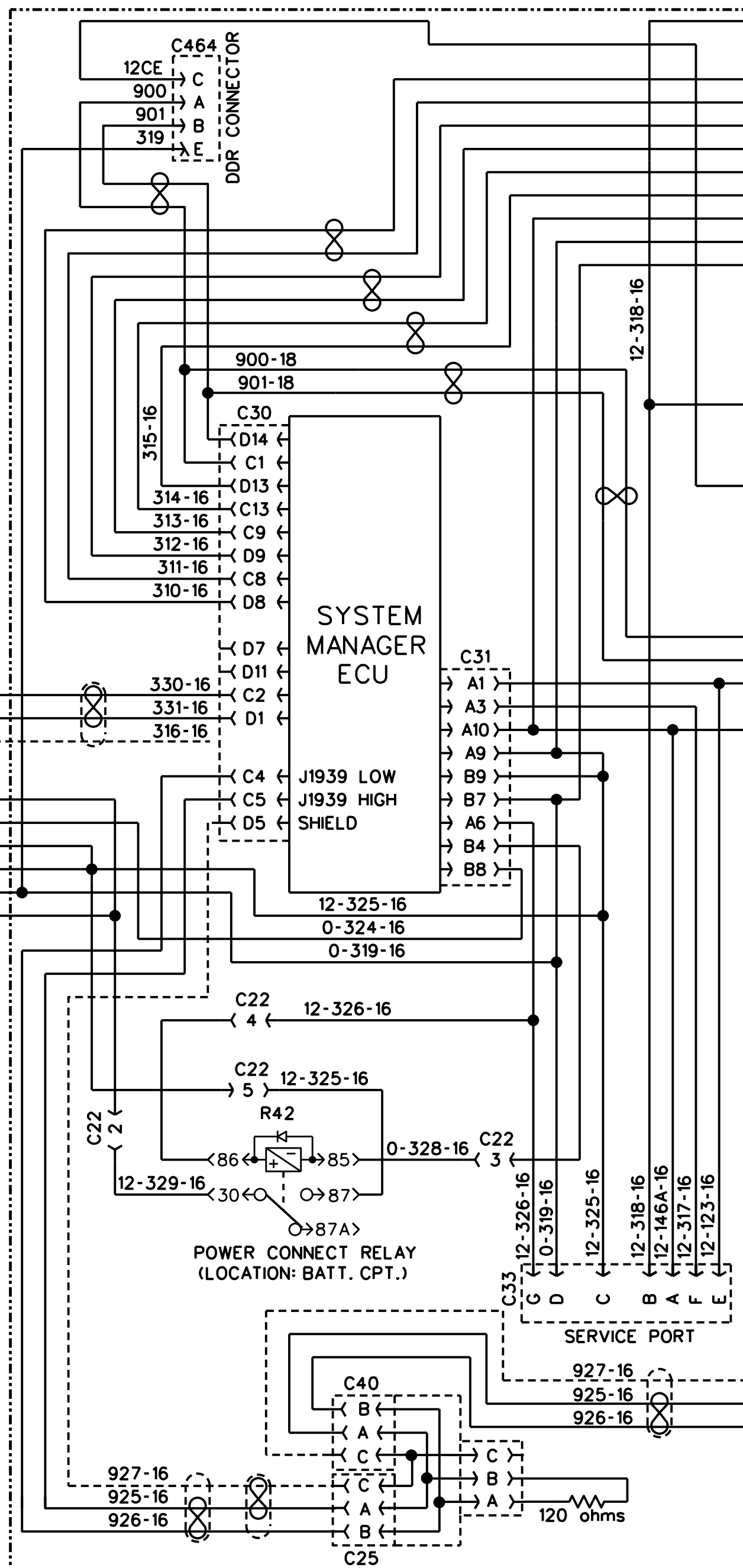
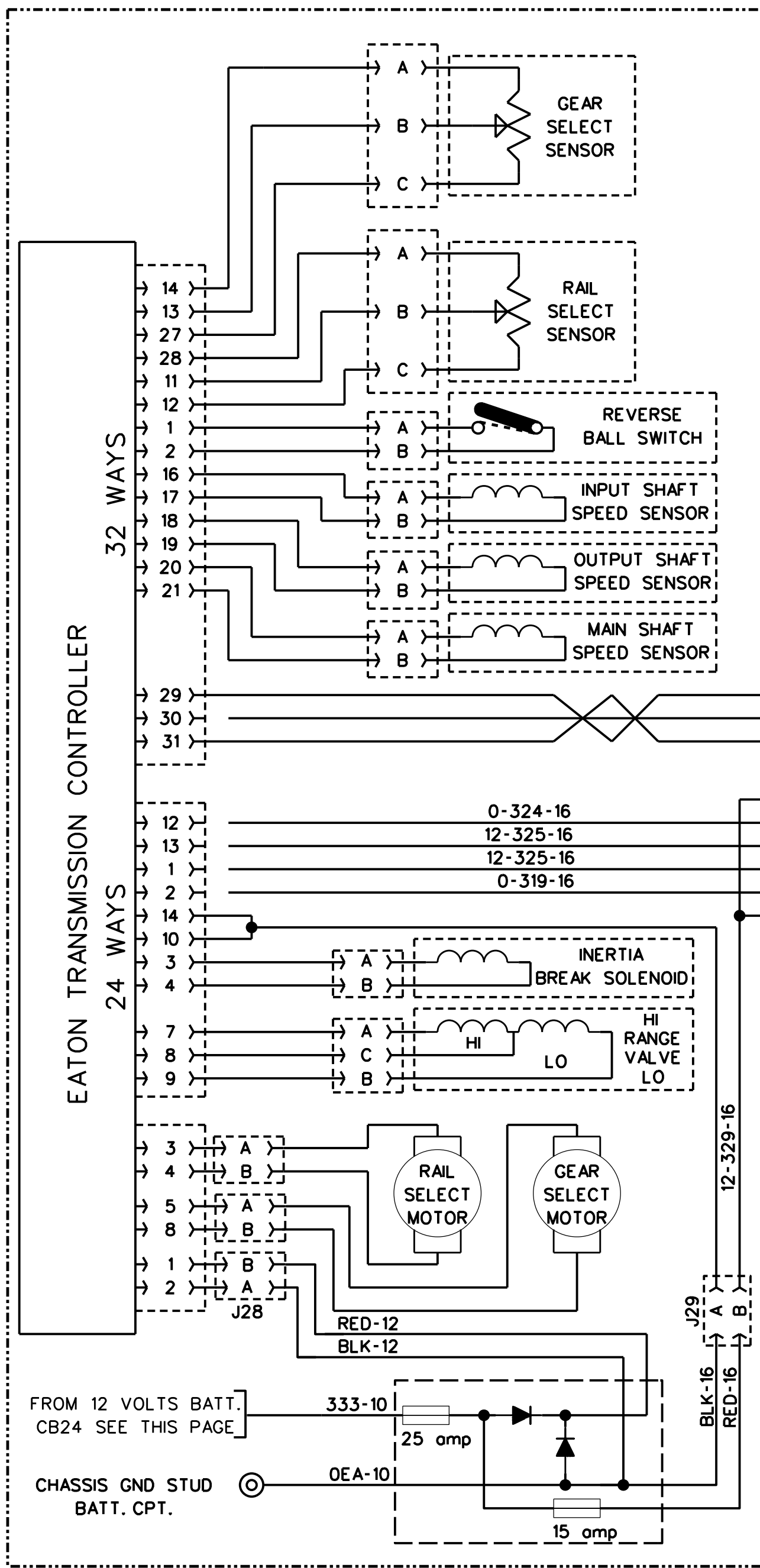

TRANSMISSION HARNESS

REAR JUNCTION COMPARTMENT

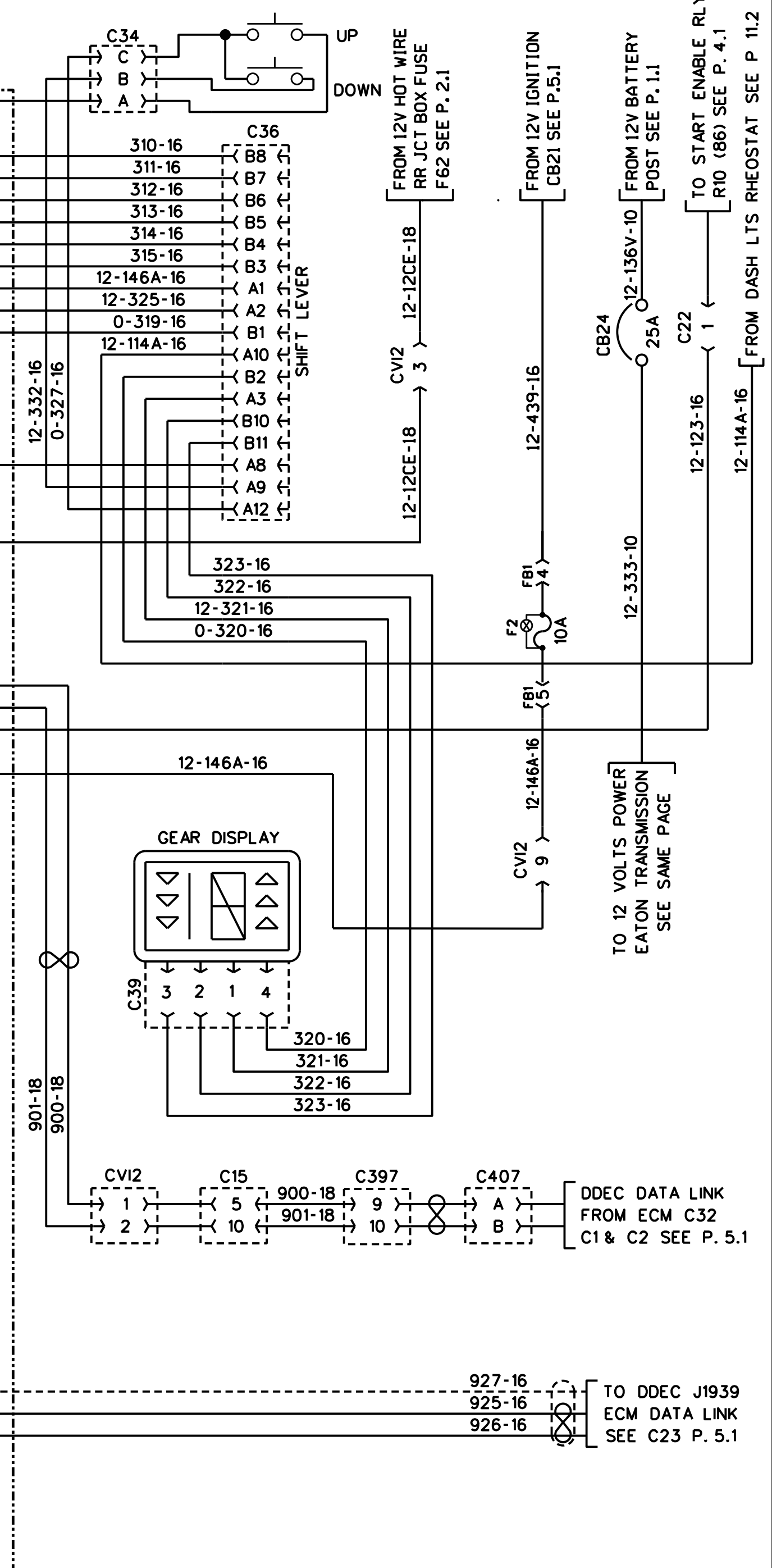
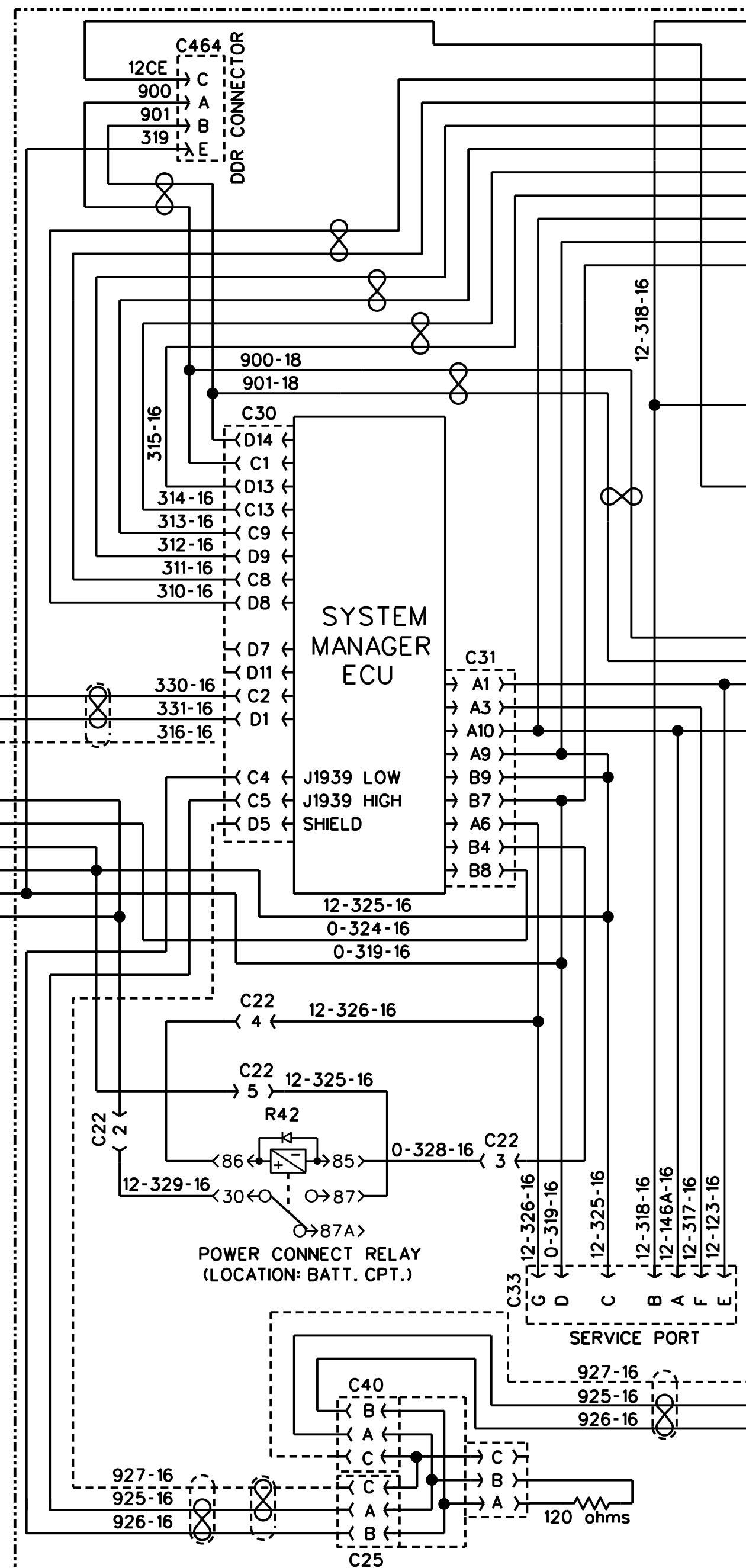
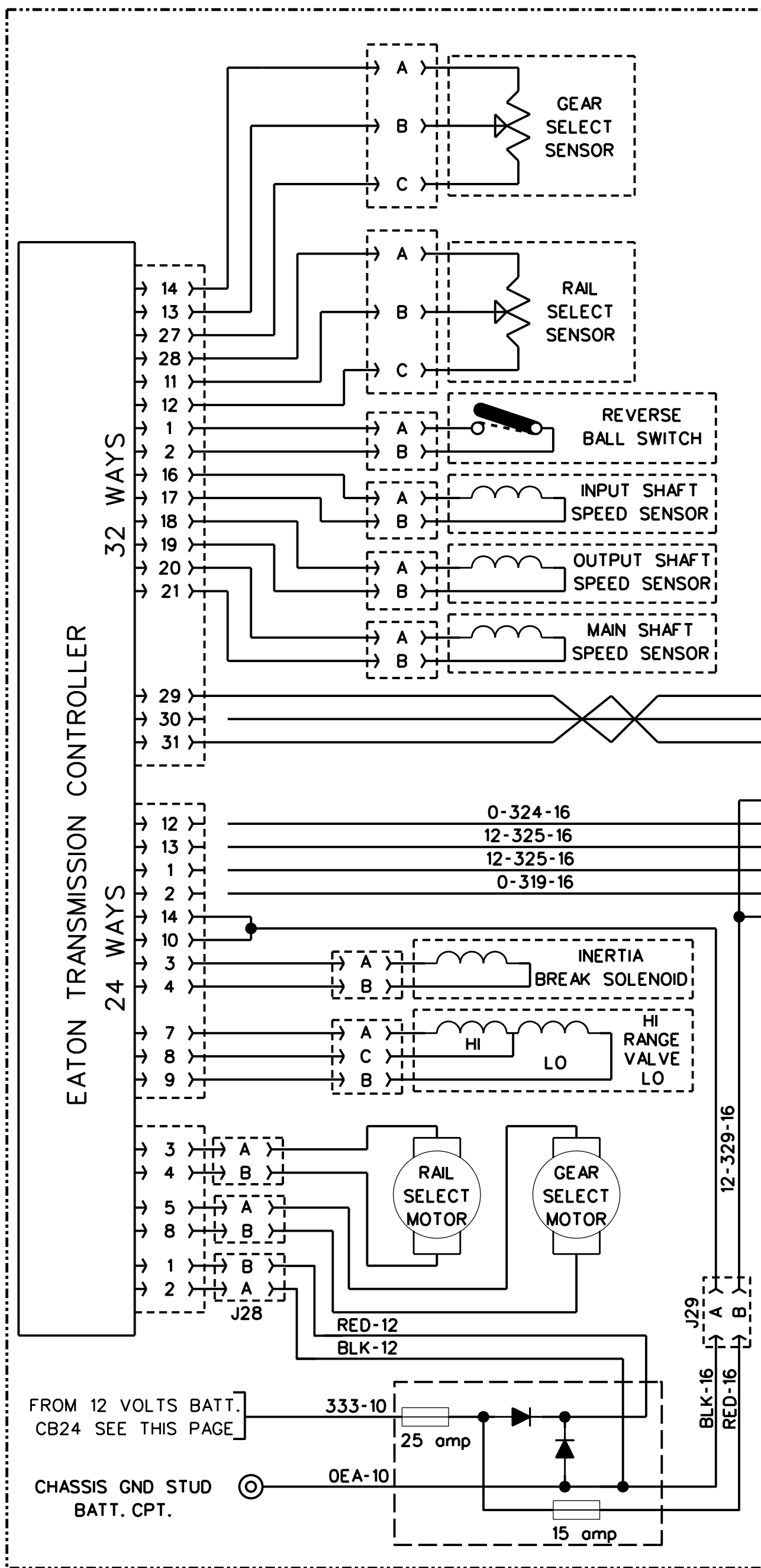

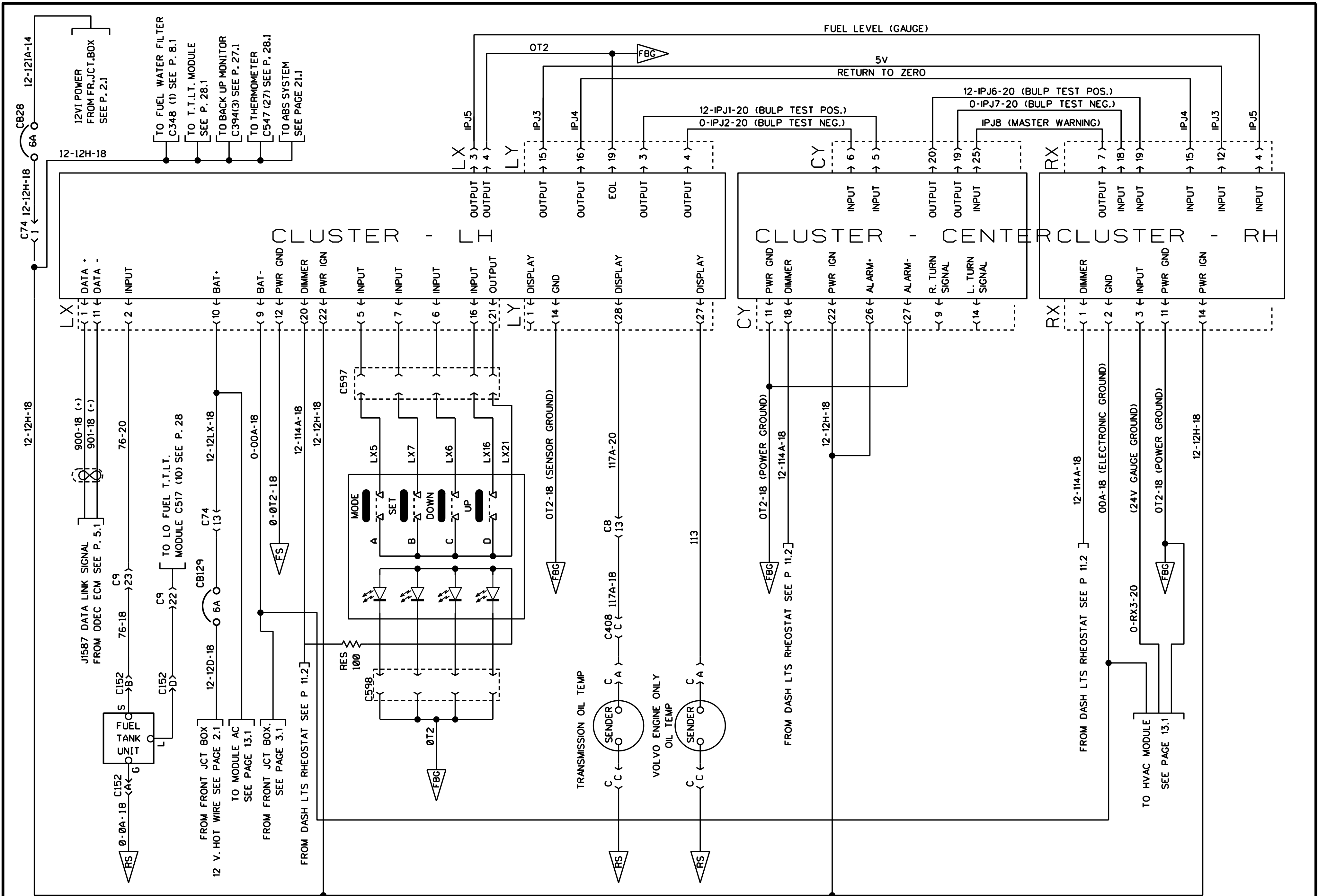

ALARM AND SIGNAL



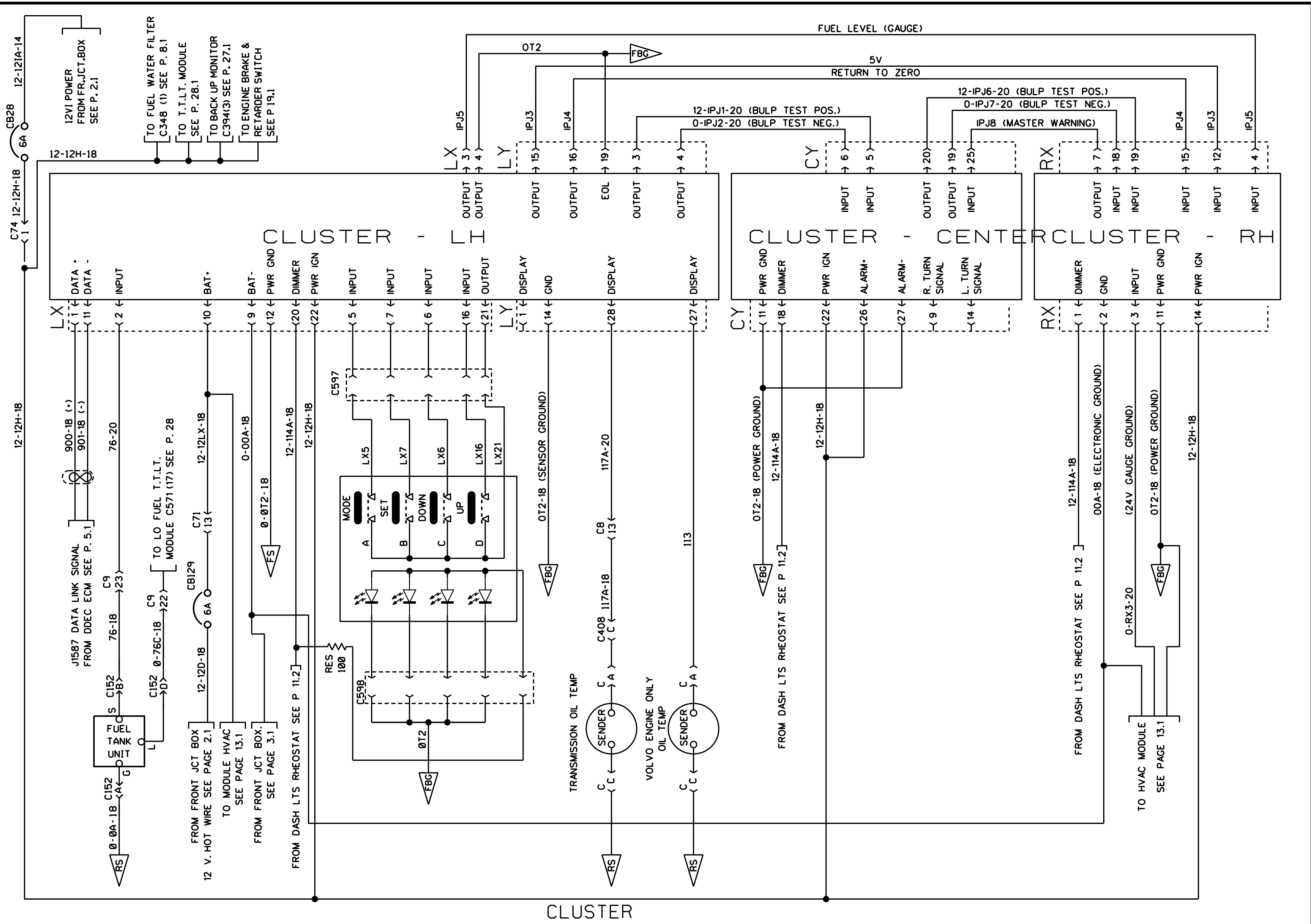

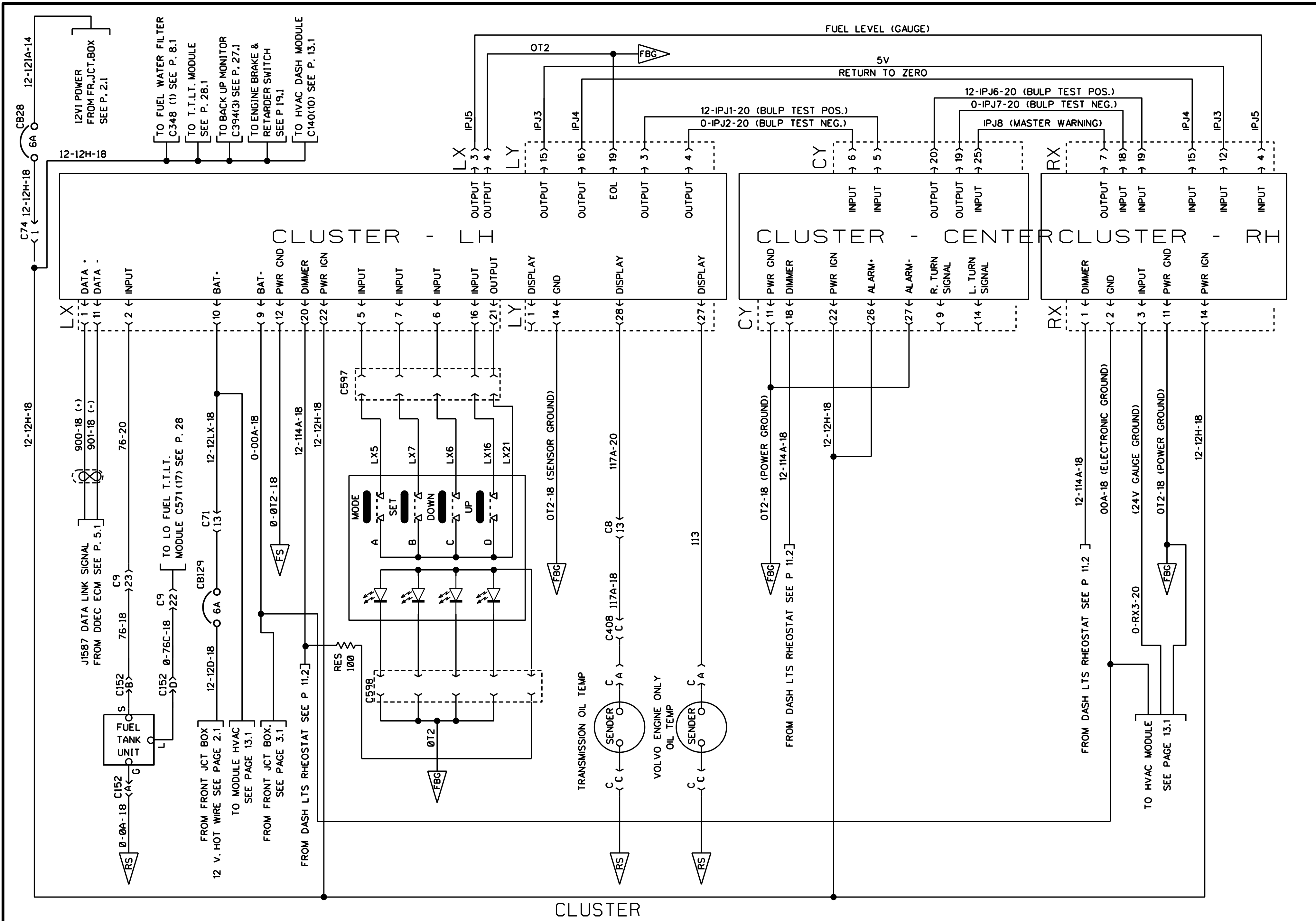

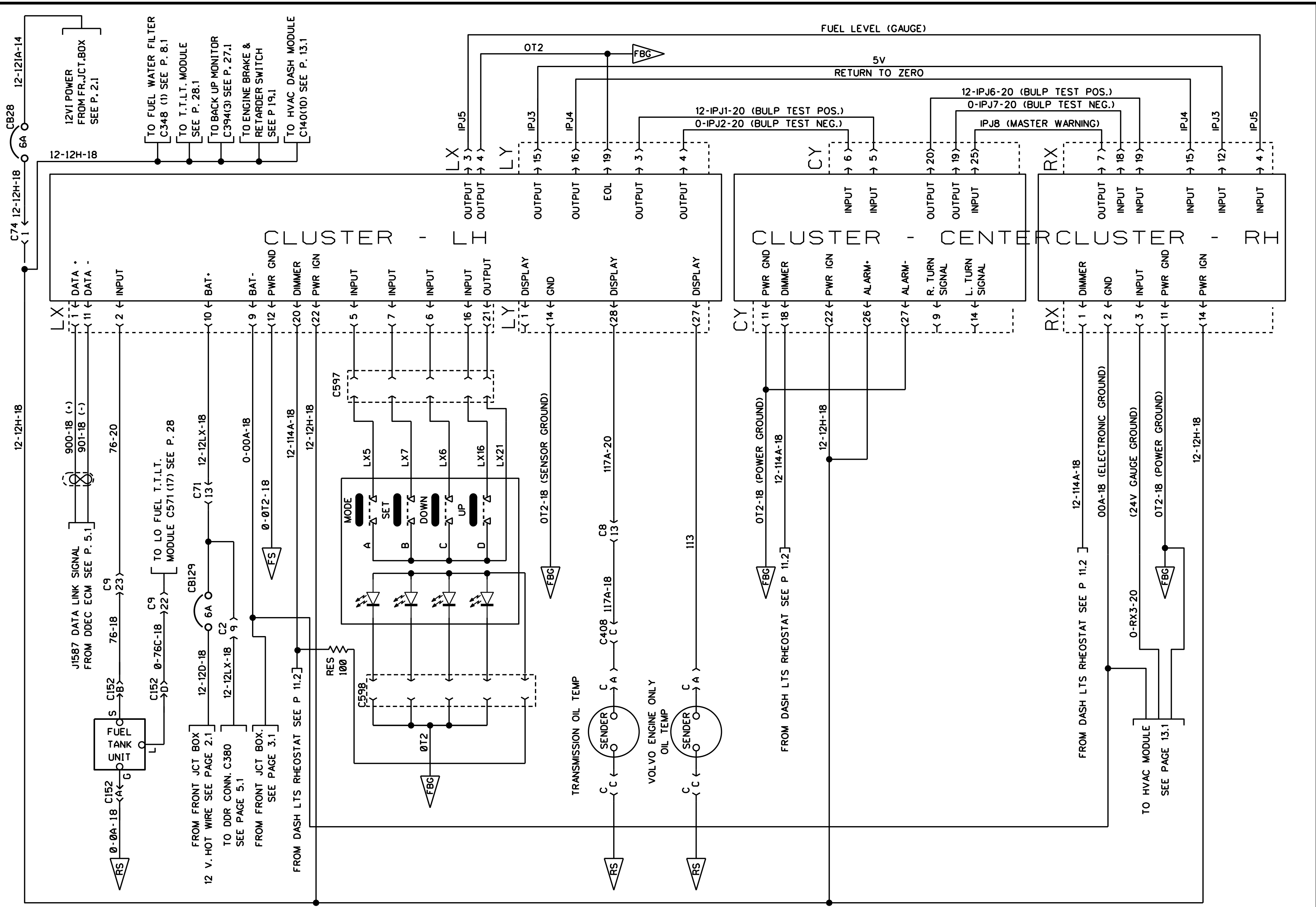

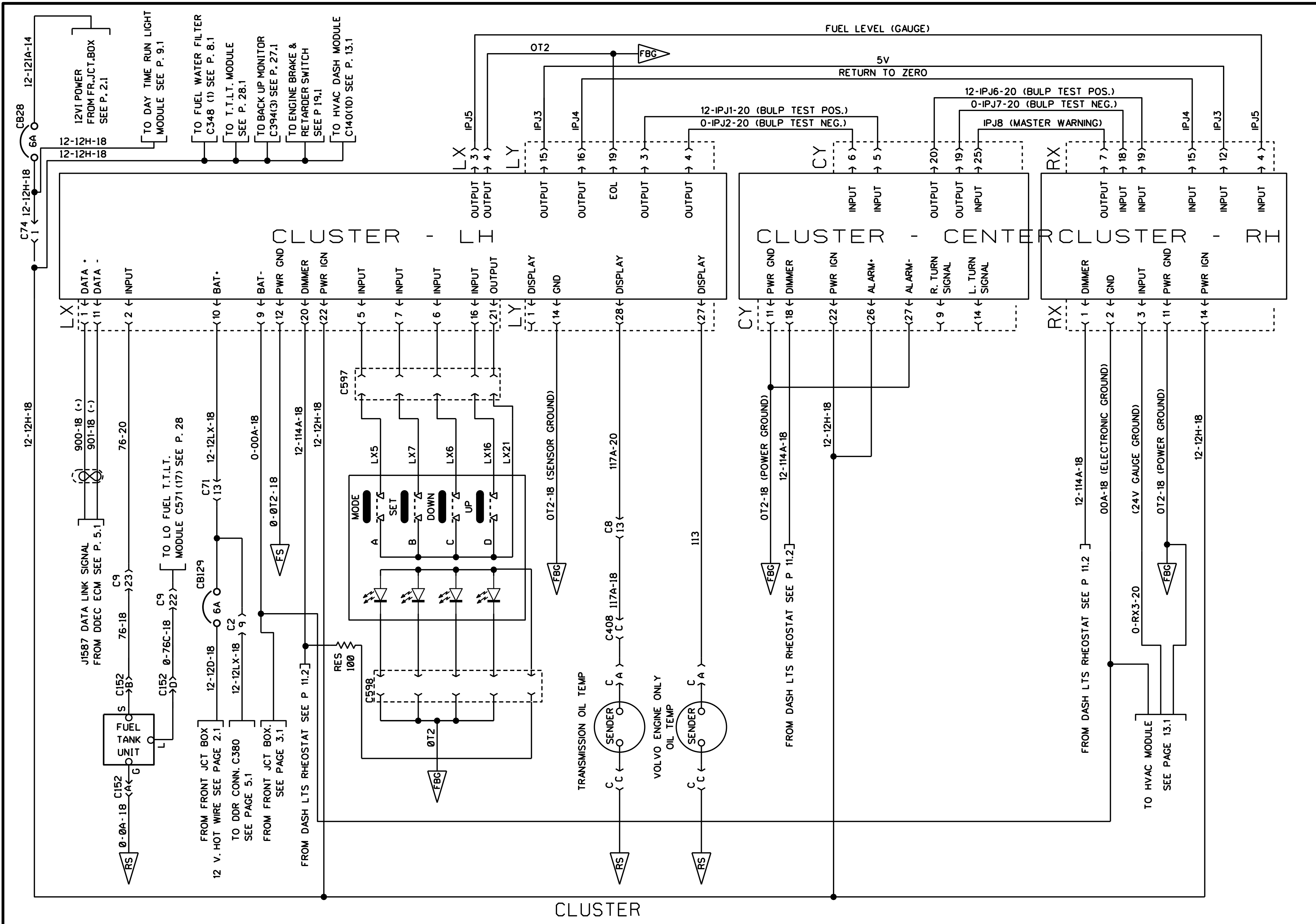

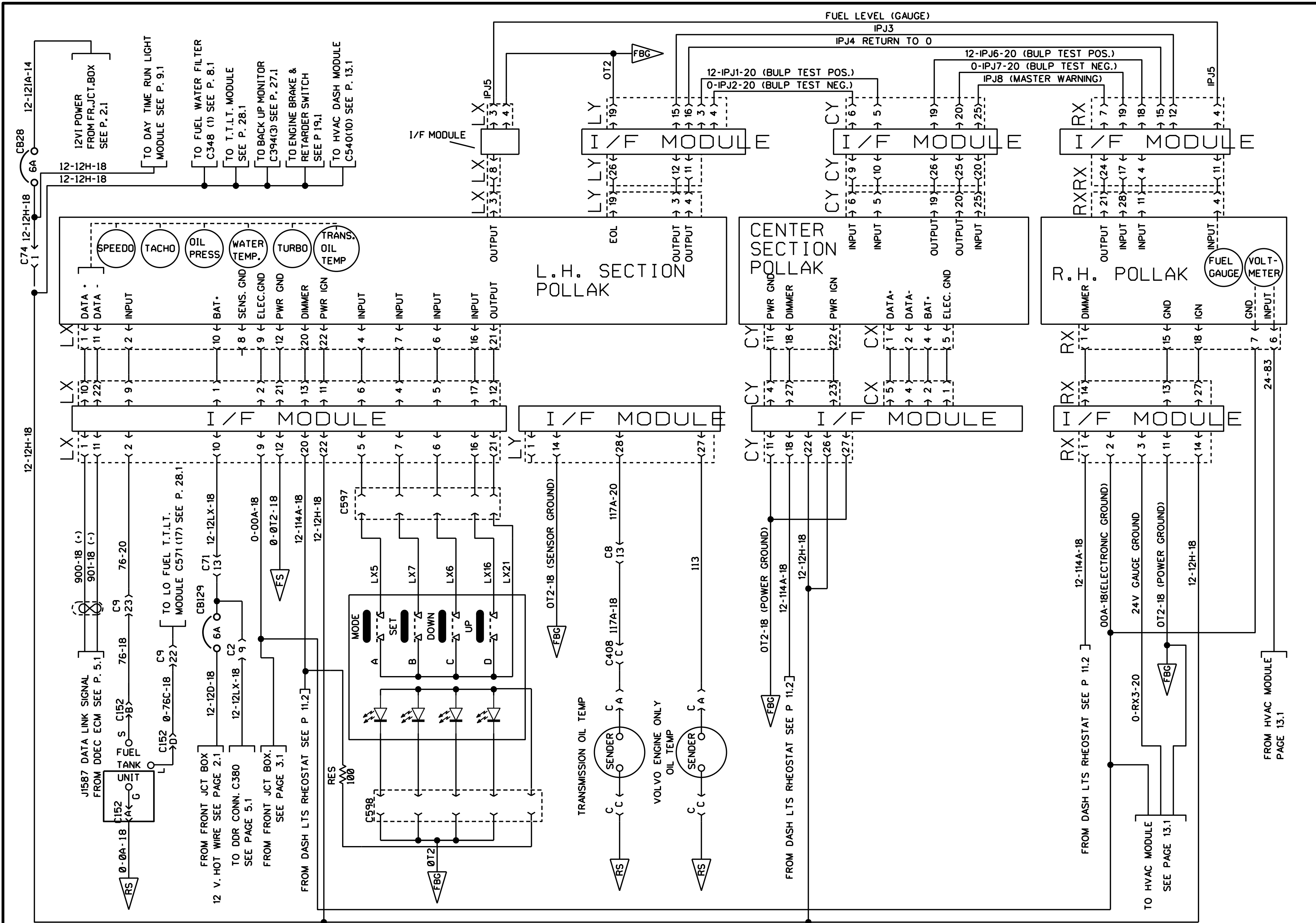

RETROFIT DIXSON TO POLLAK CLUSTER

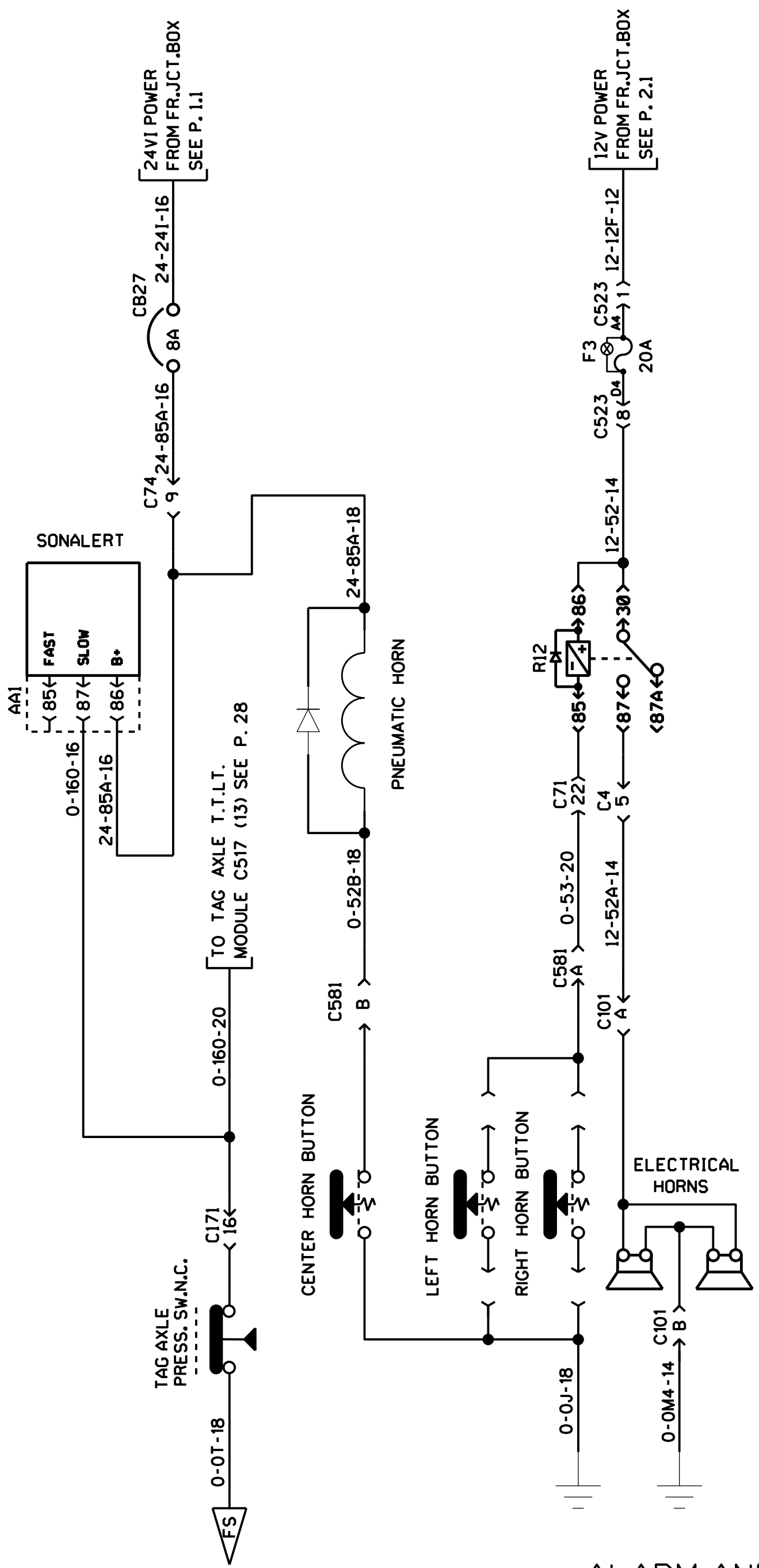

ALARM AND SIGNAL (SUITE)

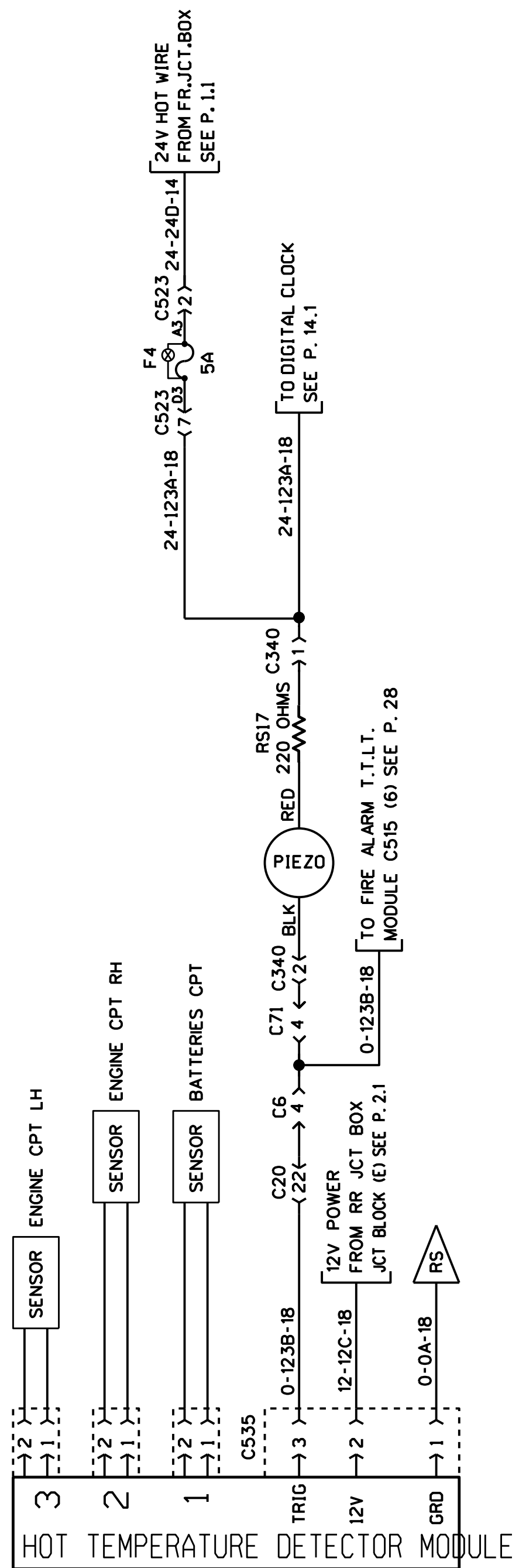

WINDOW AJAR

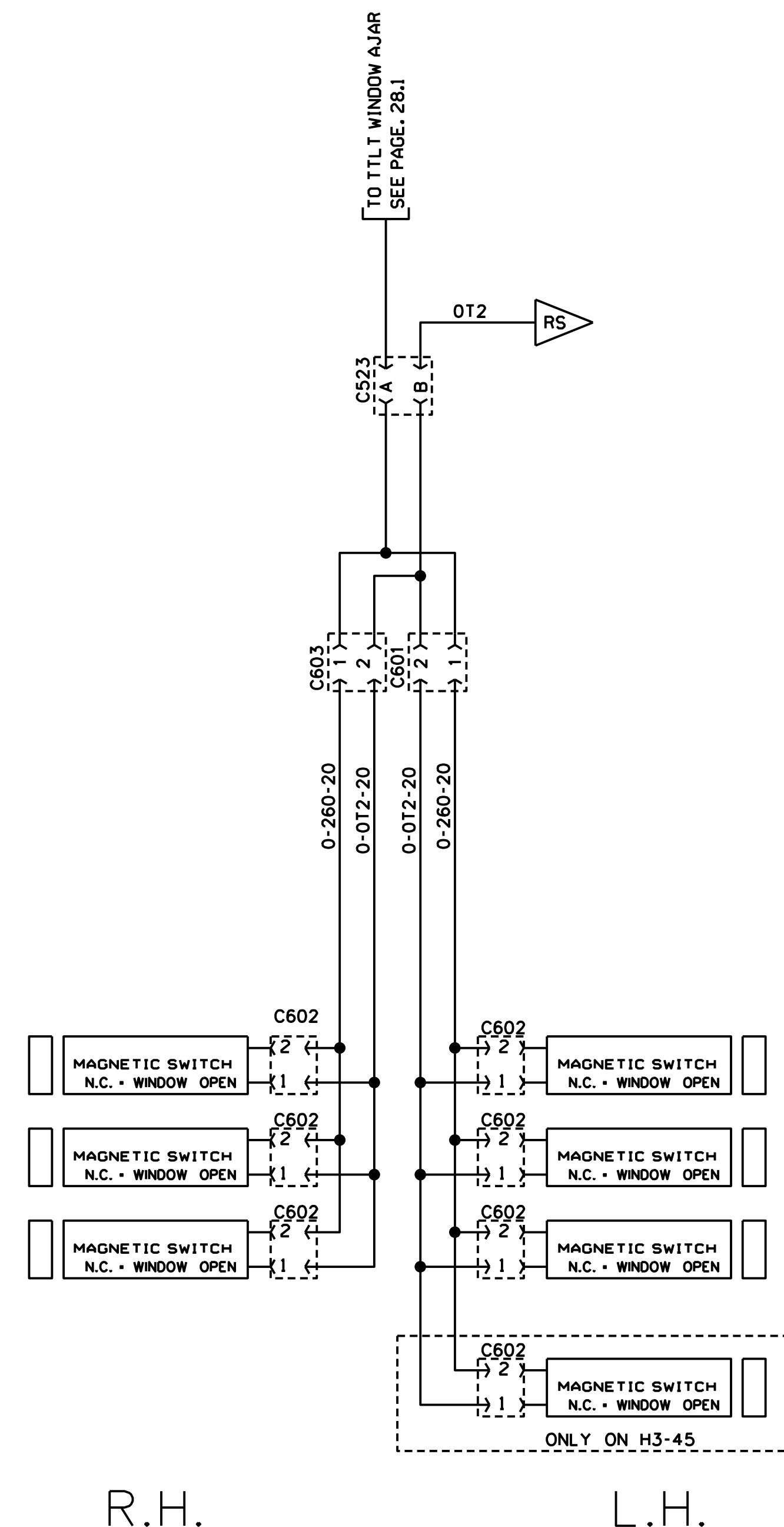

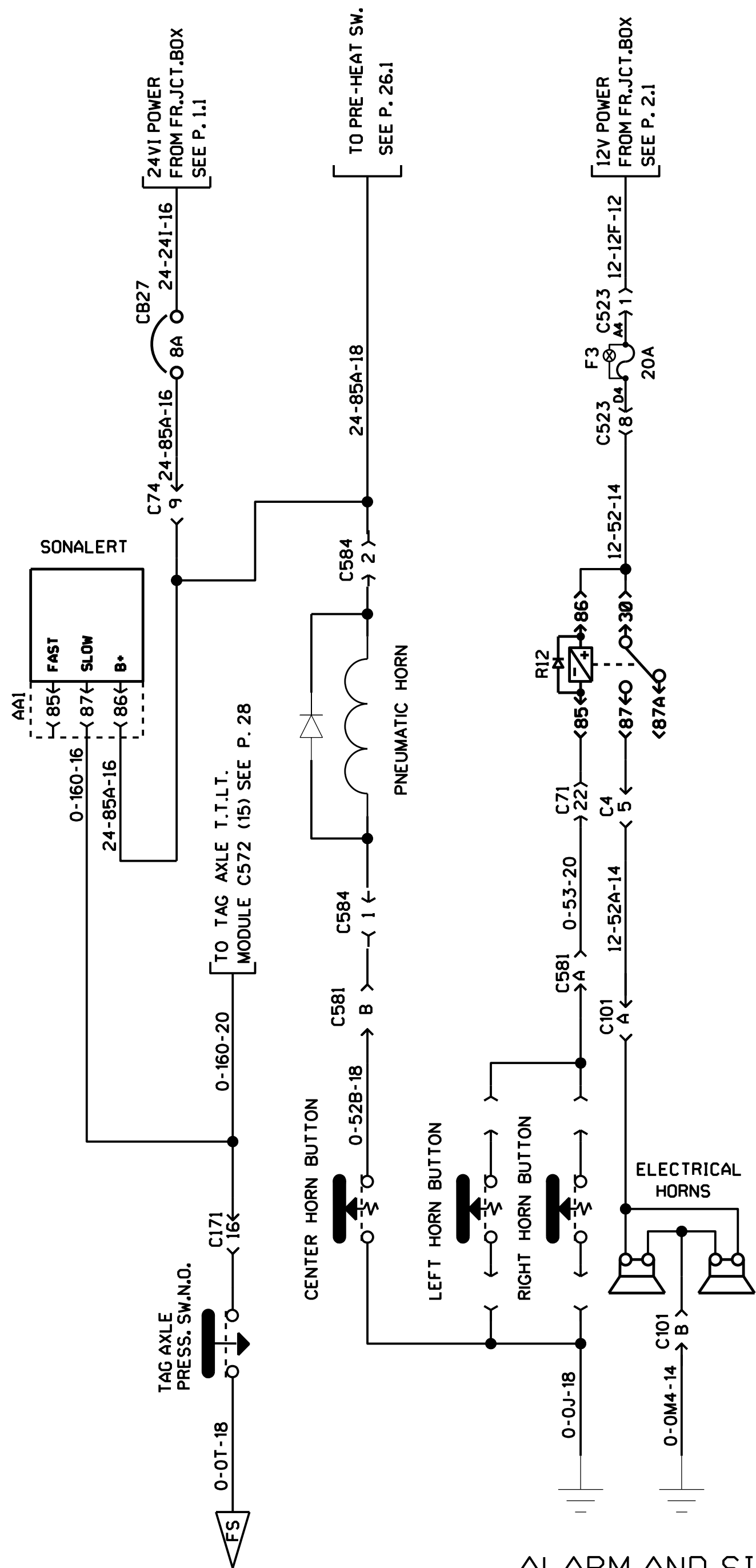

ALARM AND SIGNAL

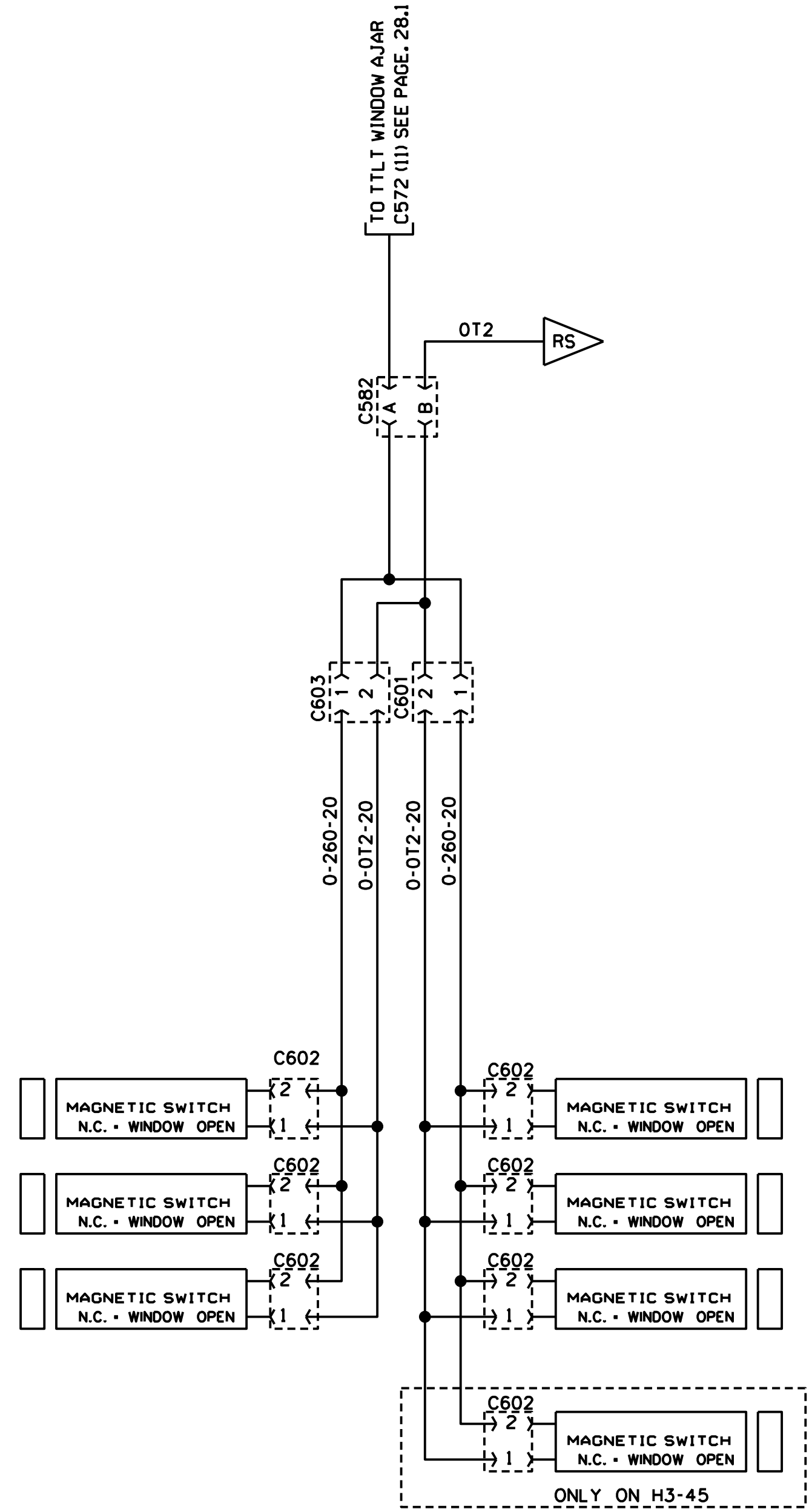
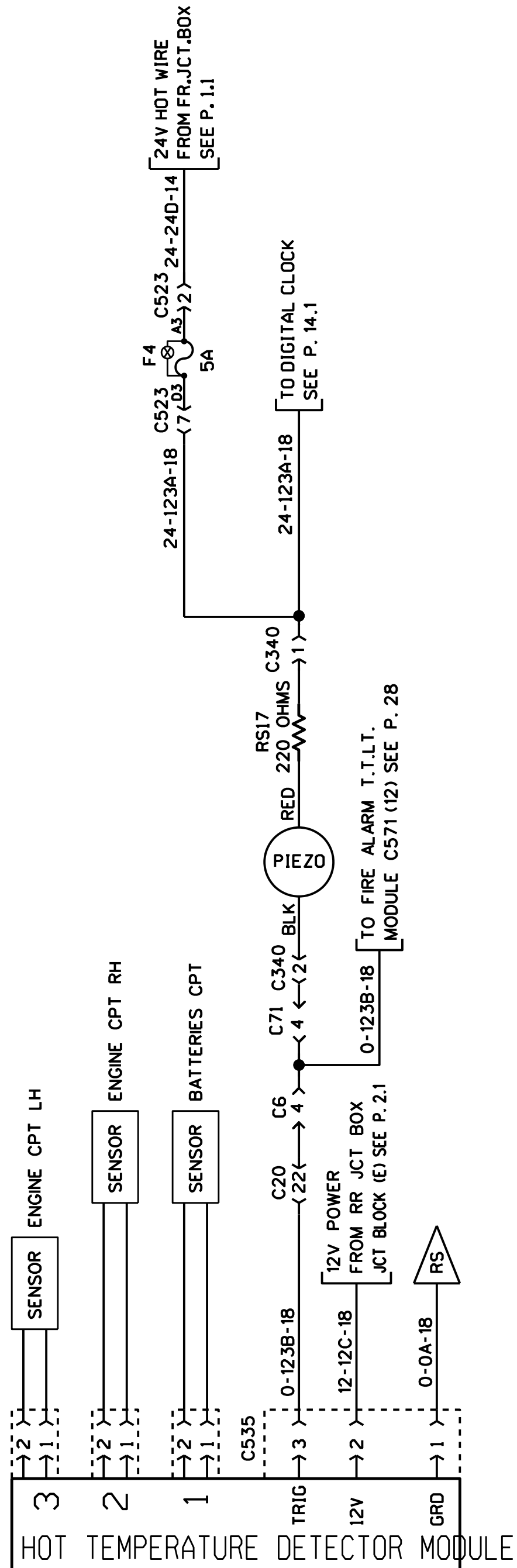

R.H.

L.H.

WINDOW AJAR



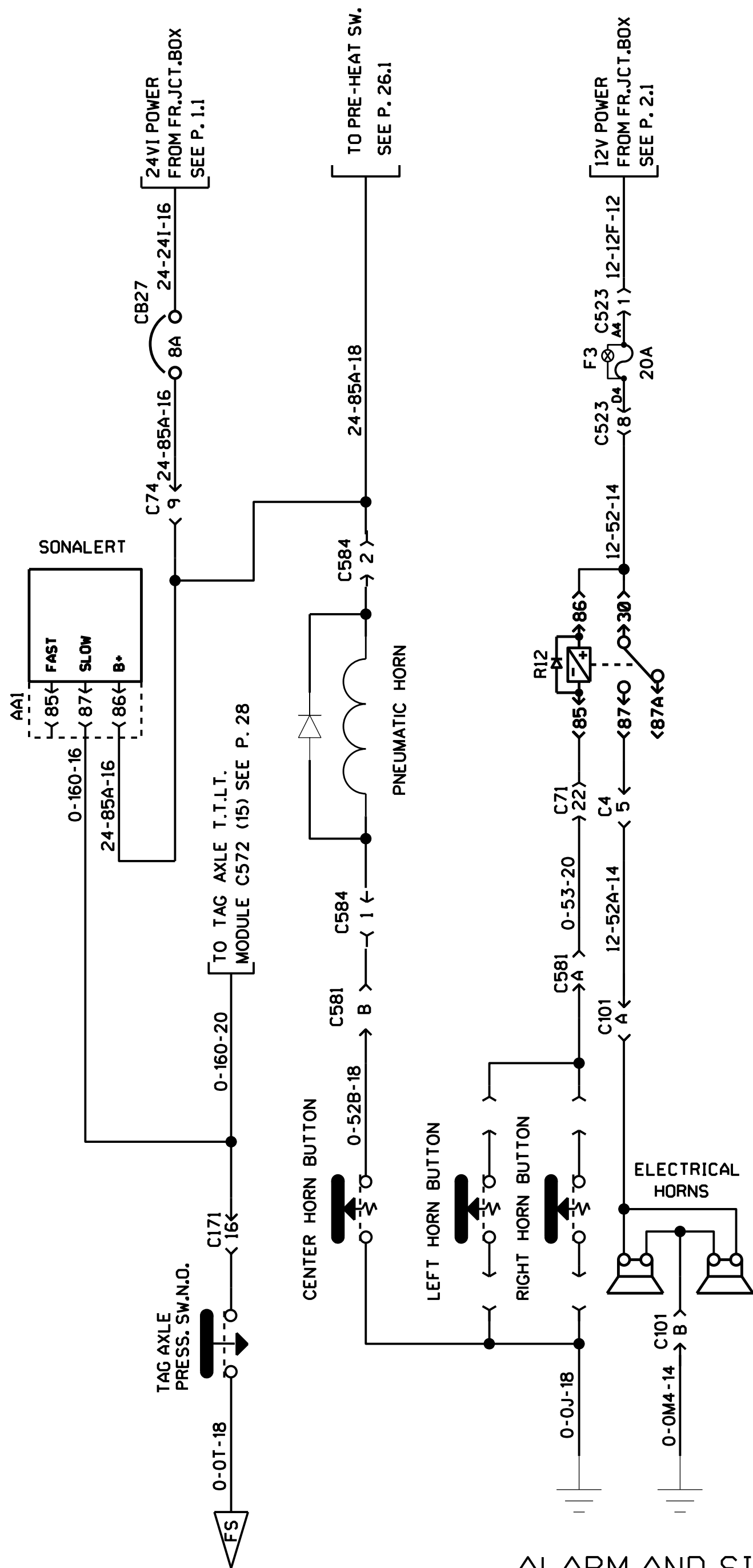

ALARM AND SIGNAL

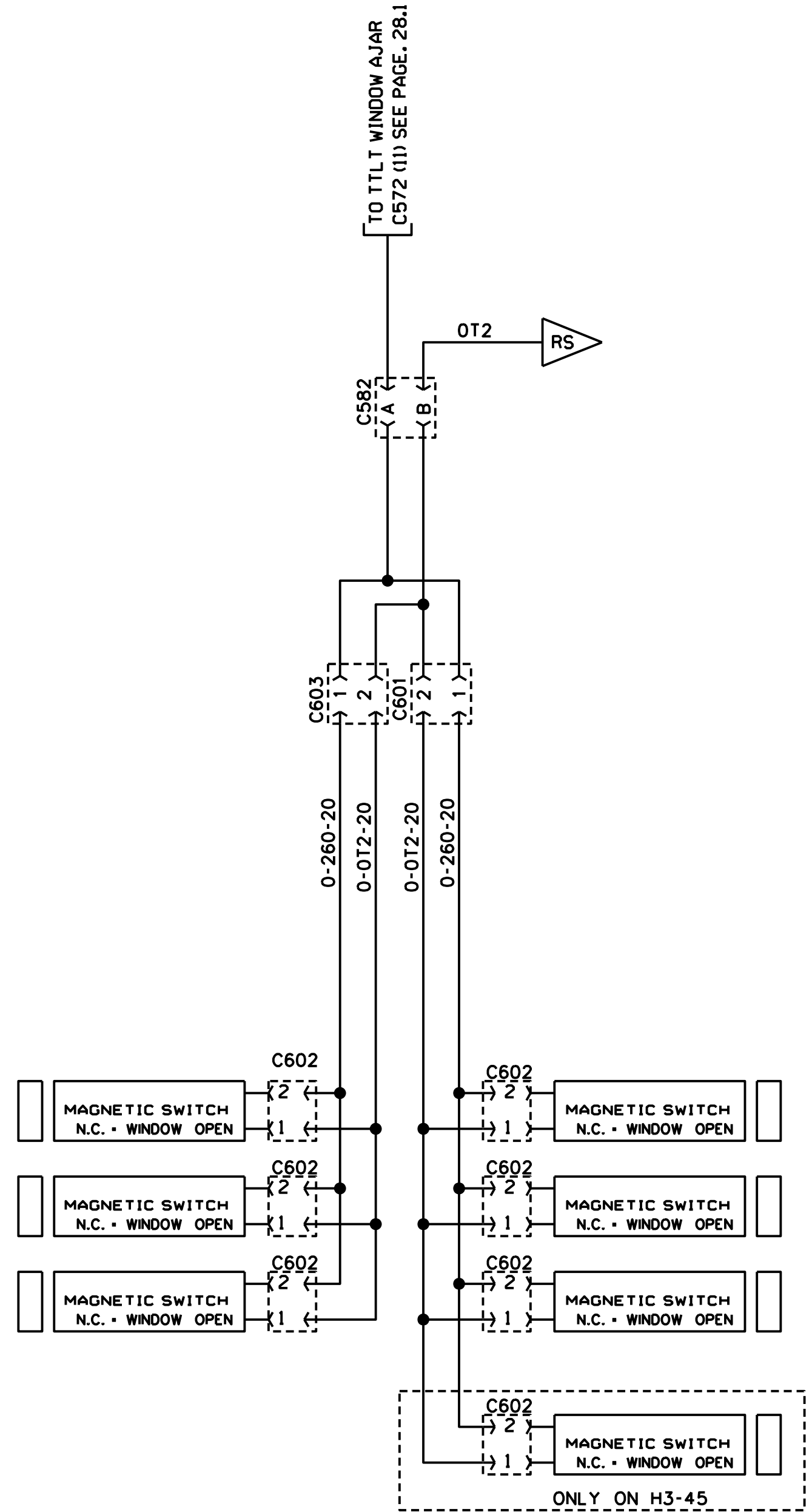
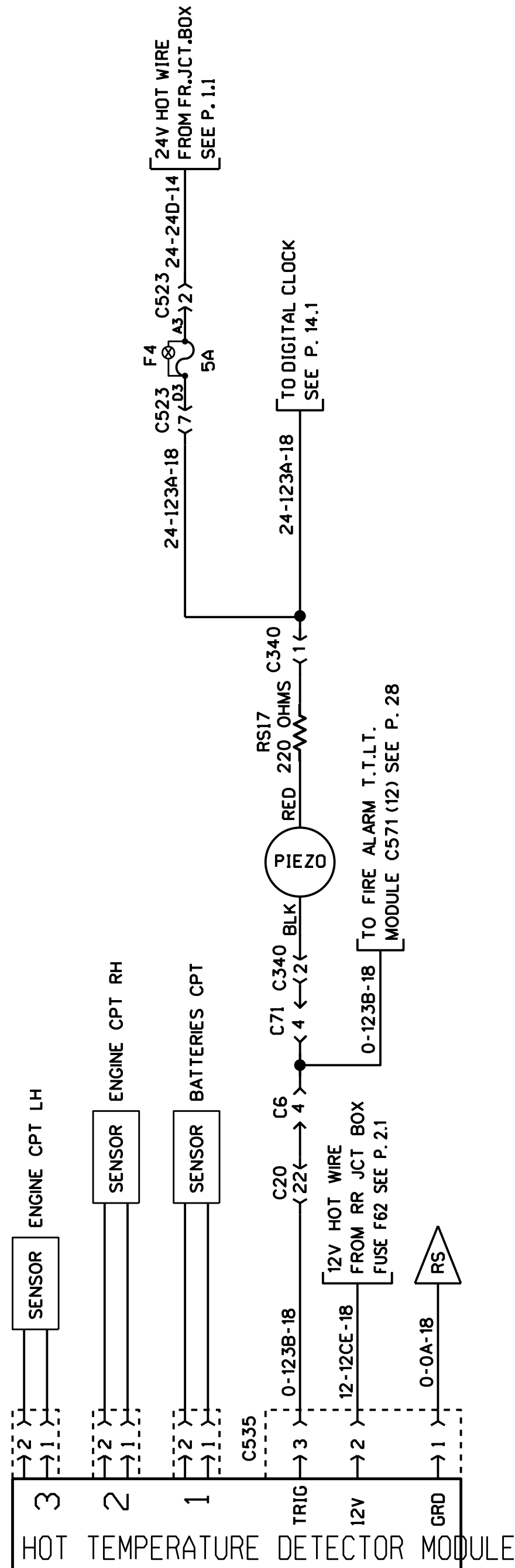

R.H.

L.H.

WINDOW AJAR



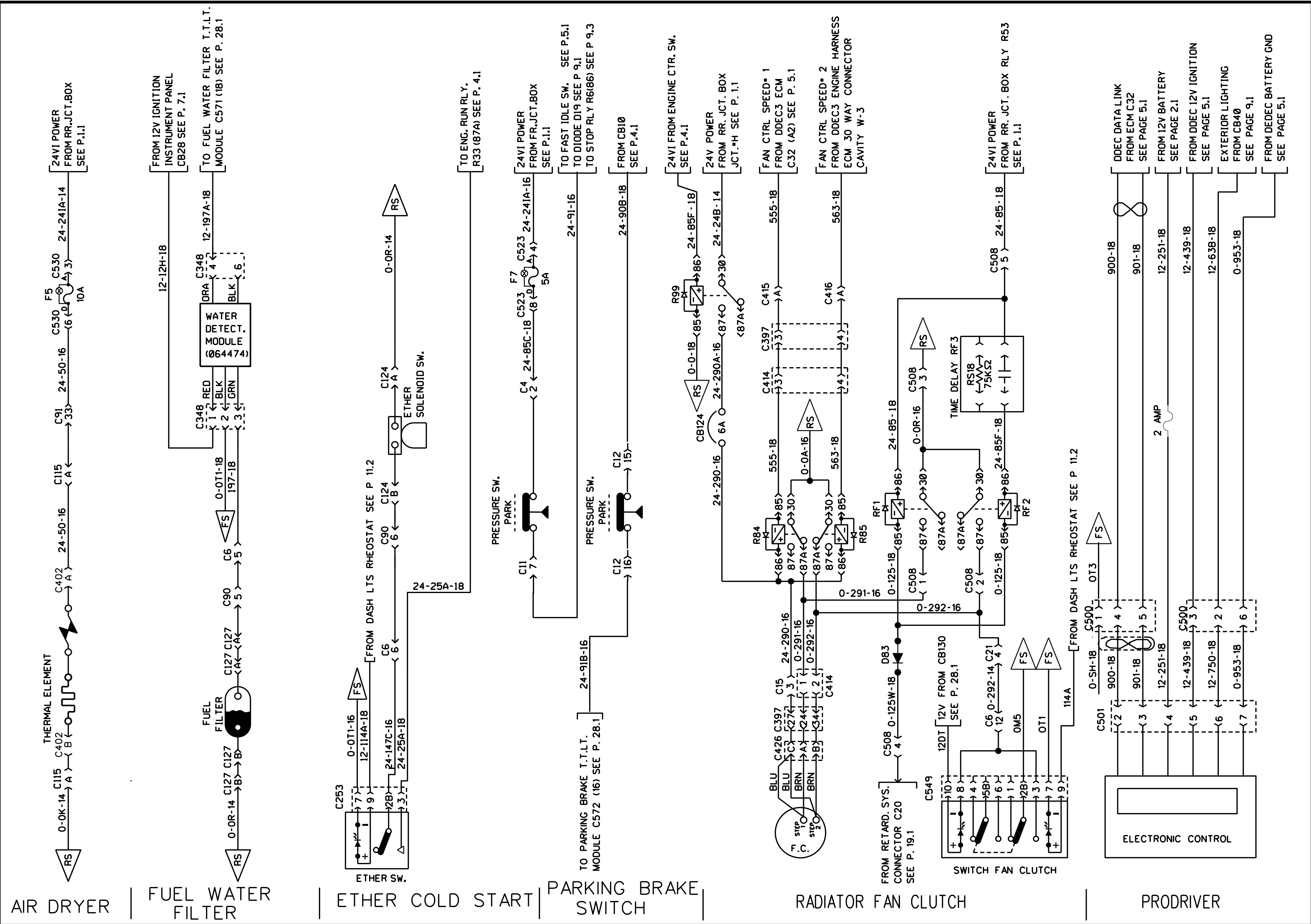

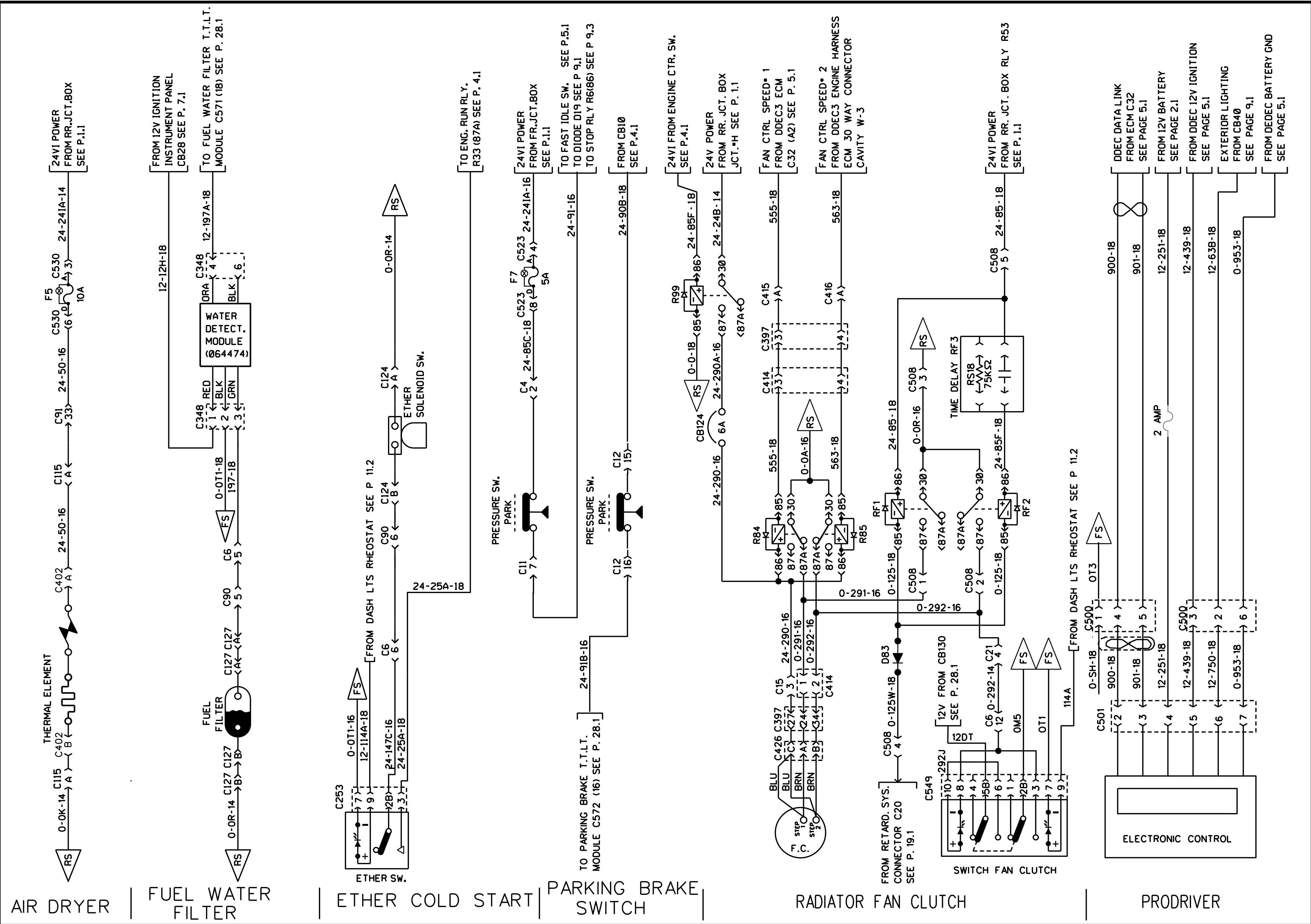

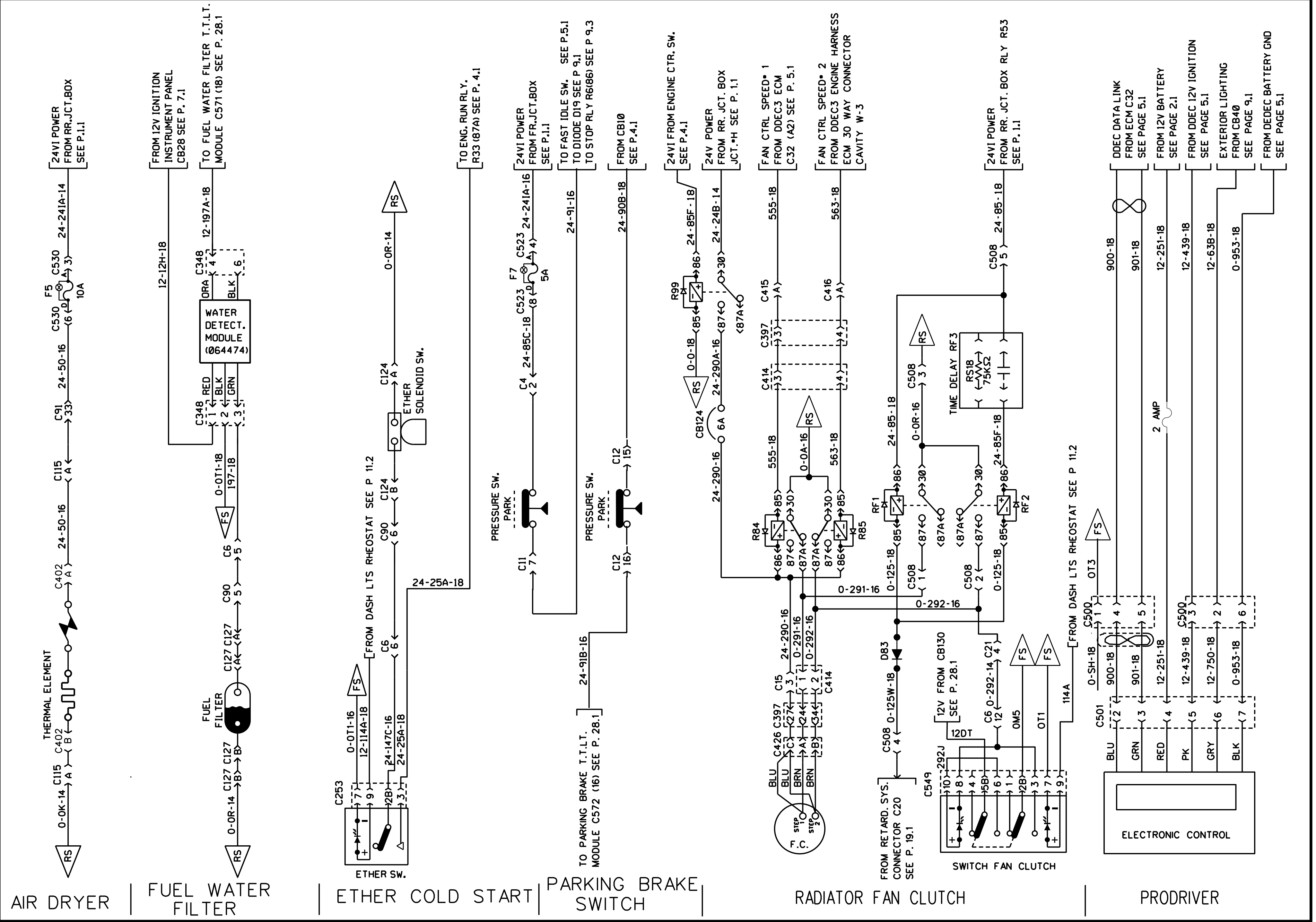

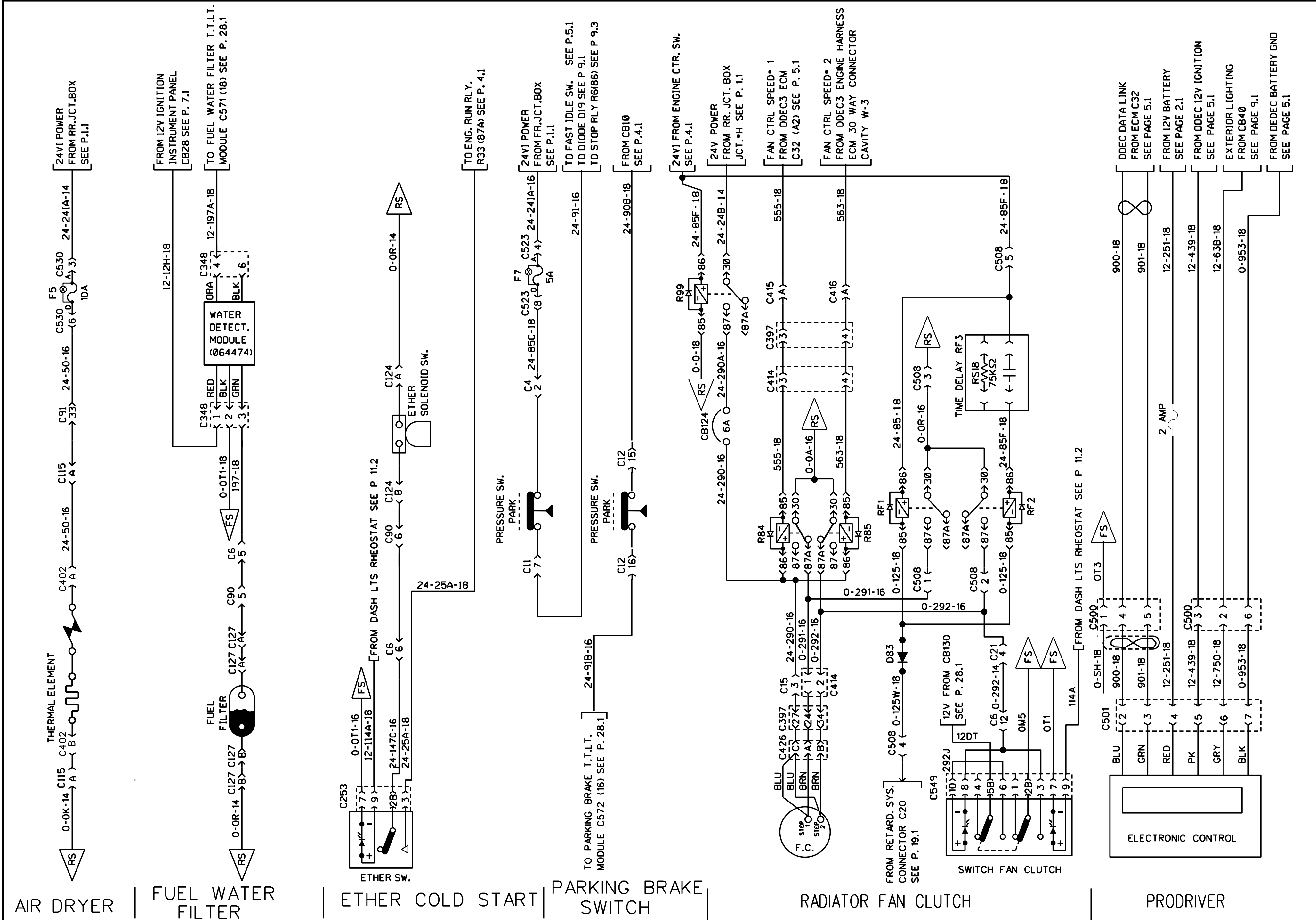





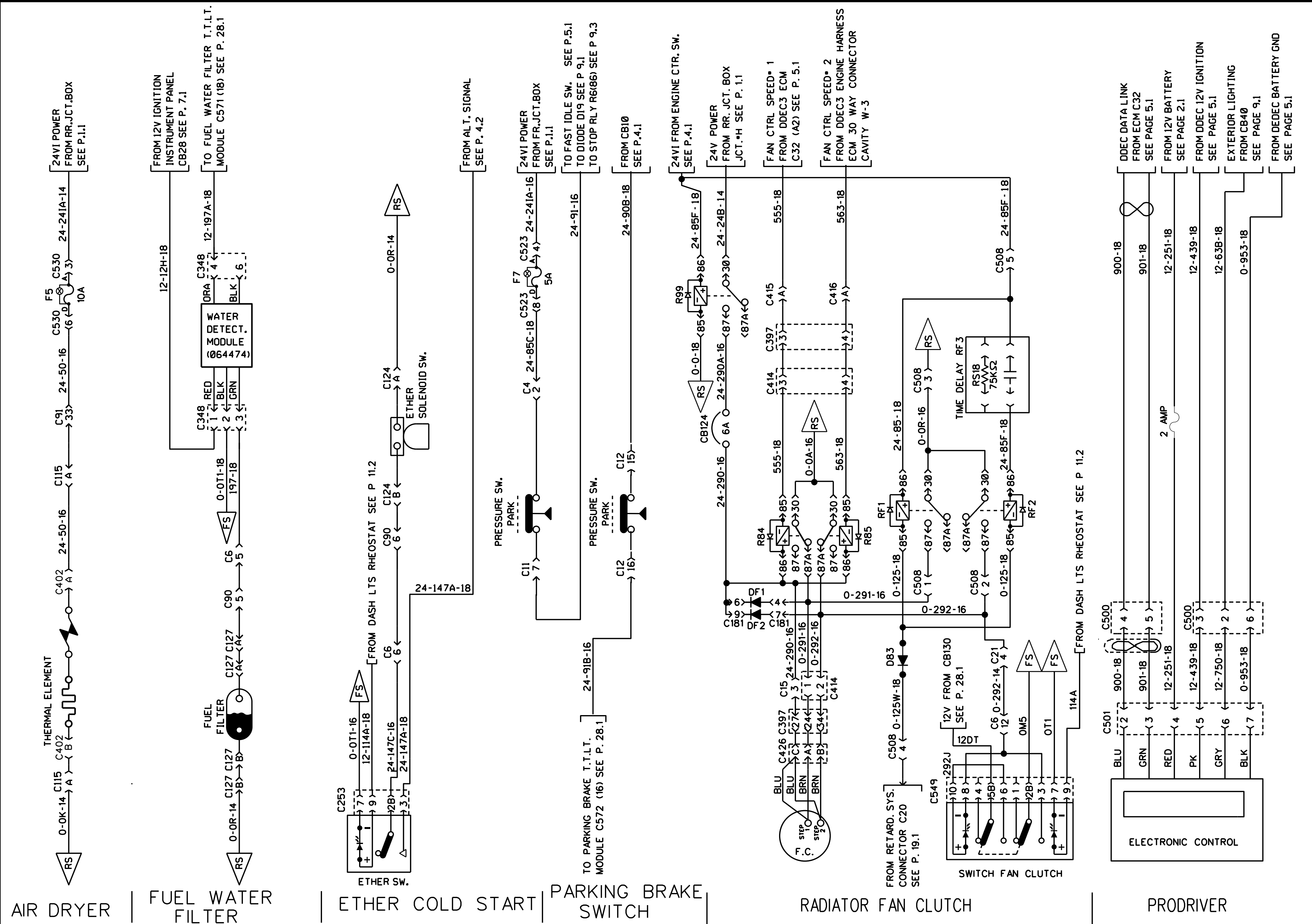

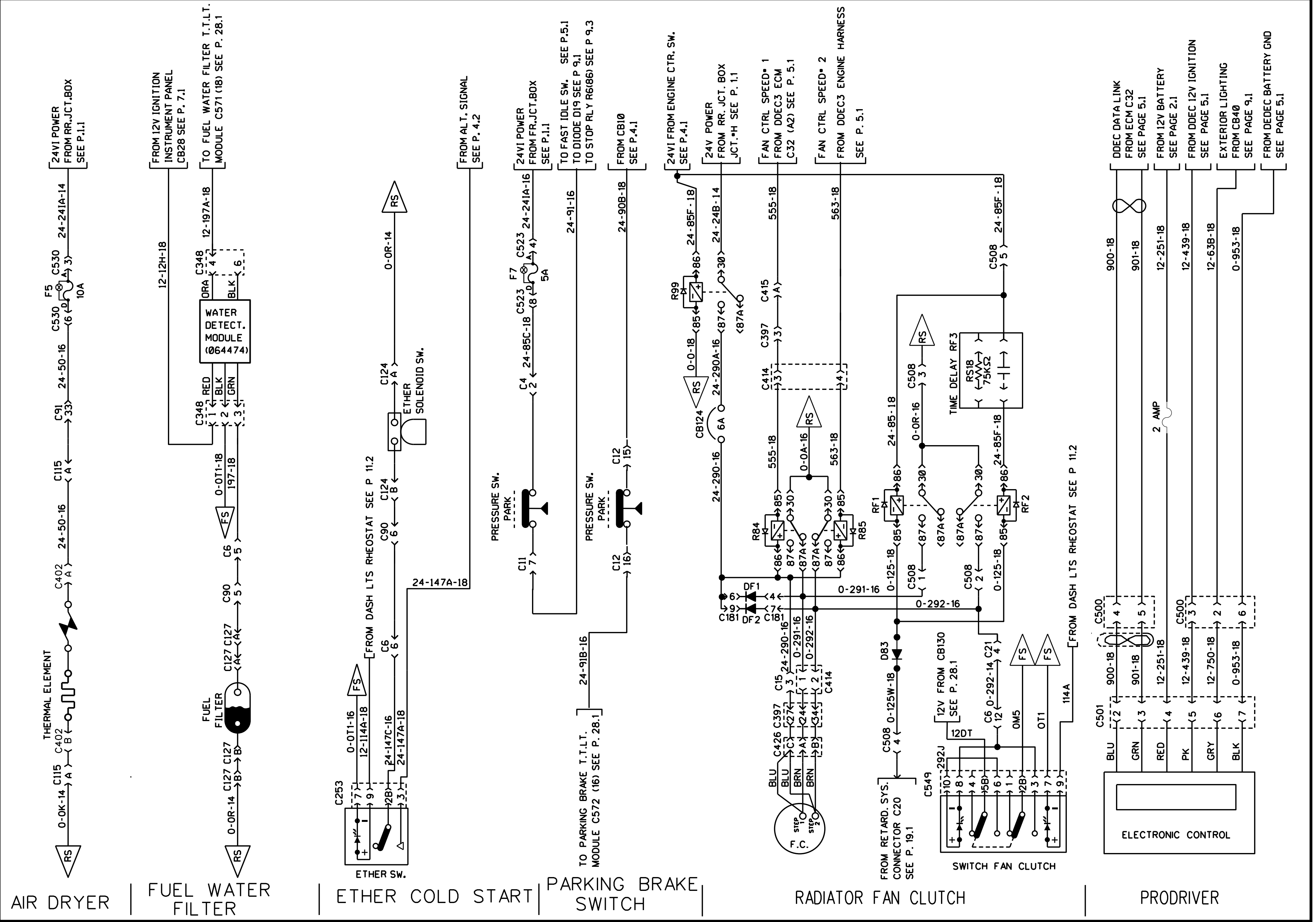

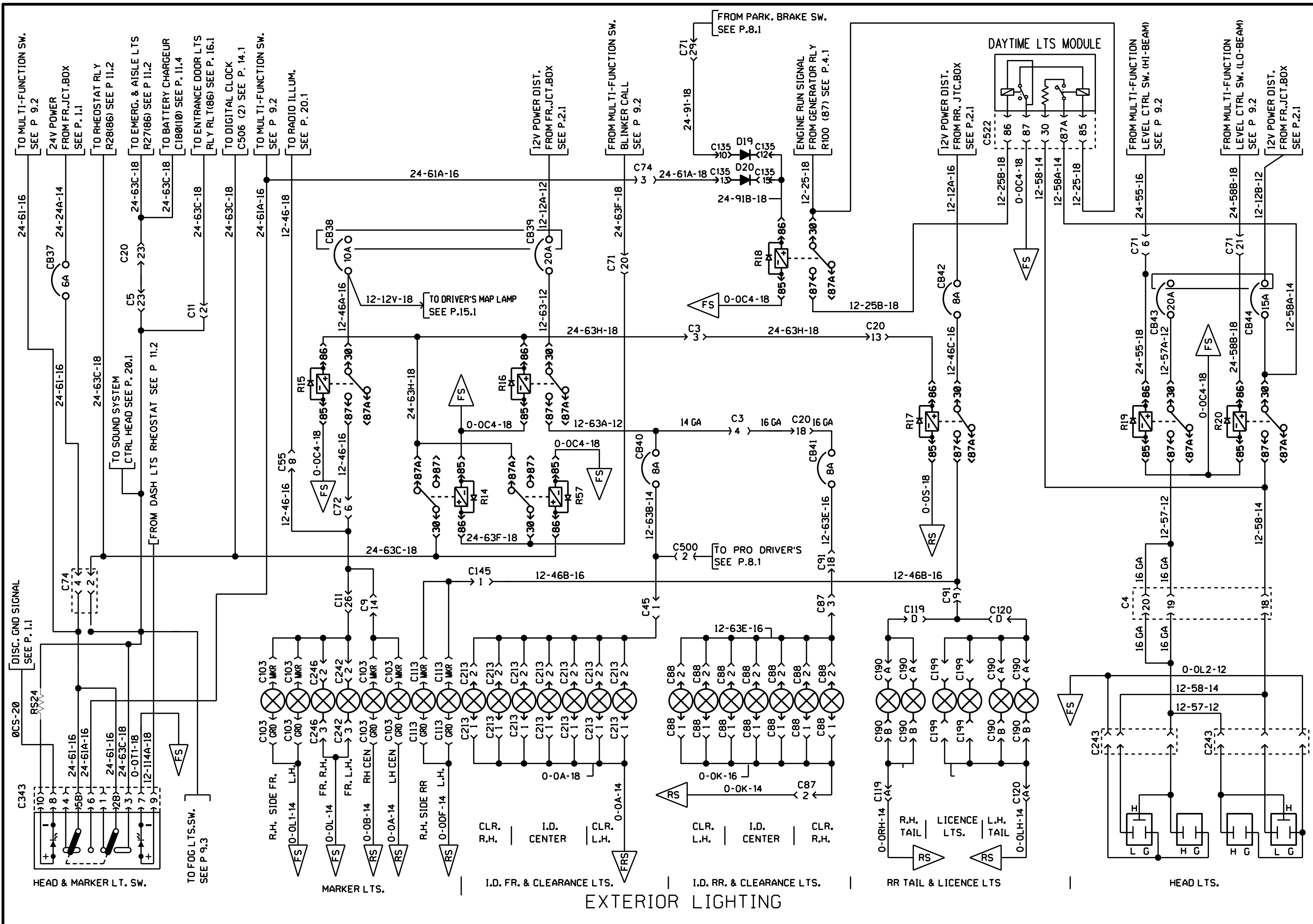

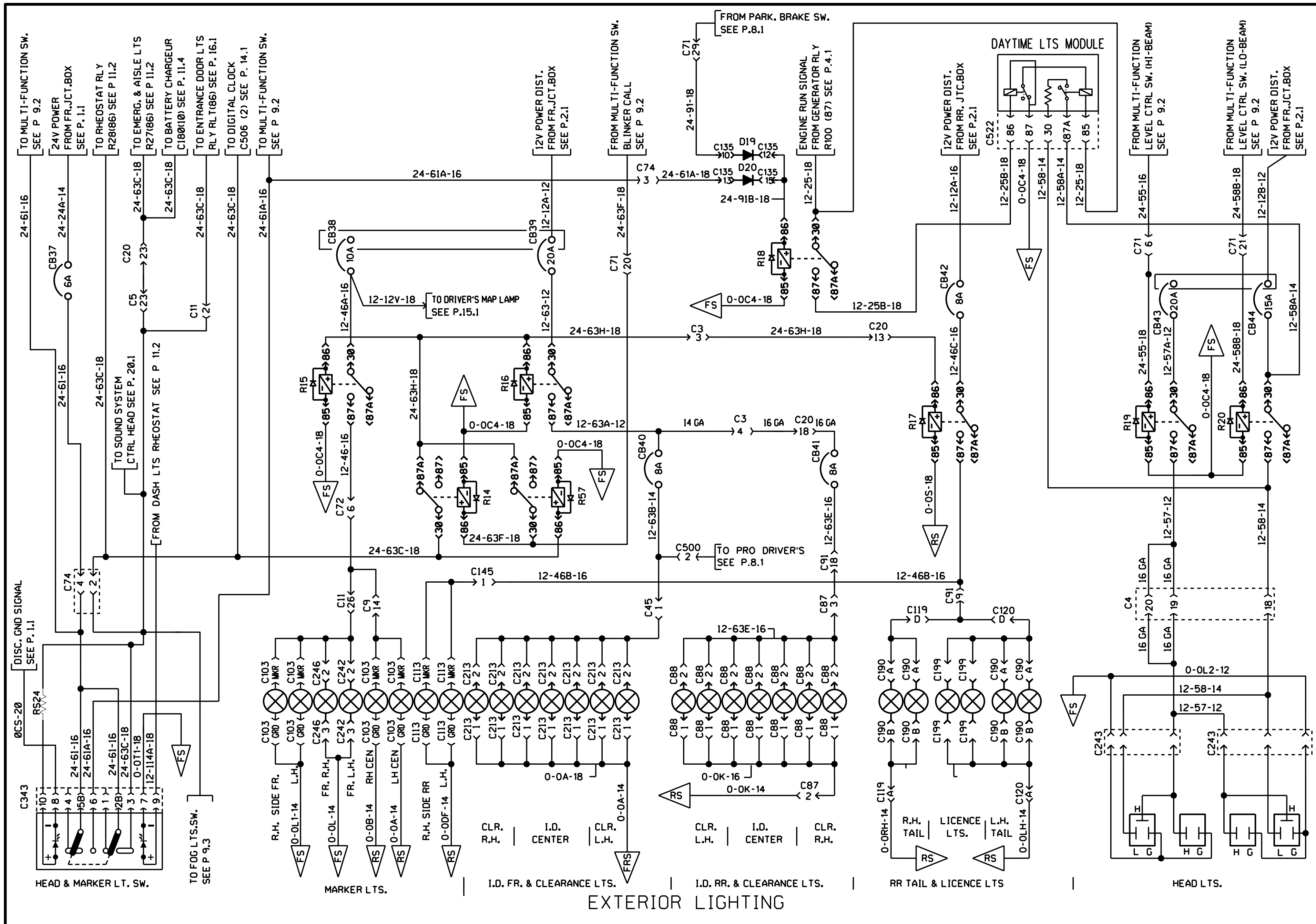

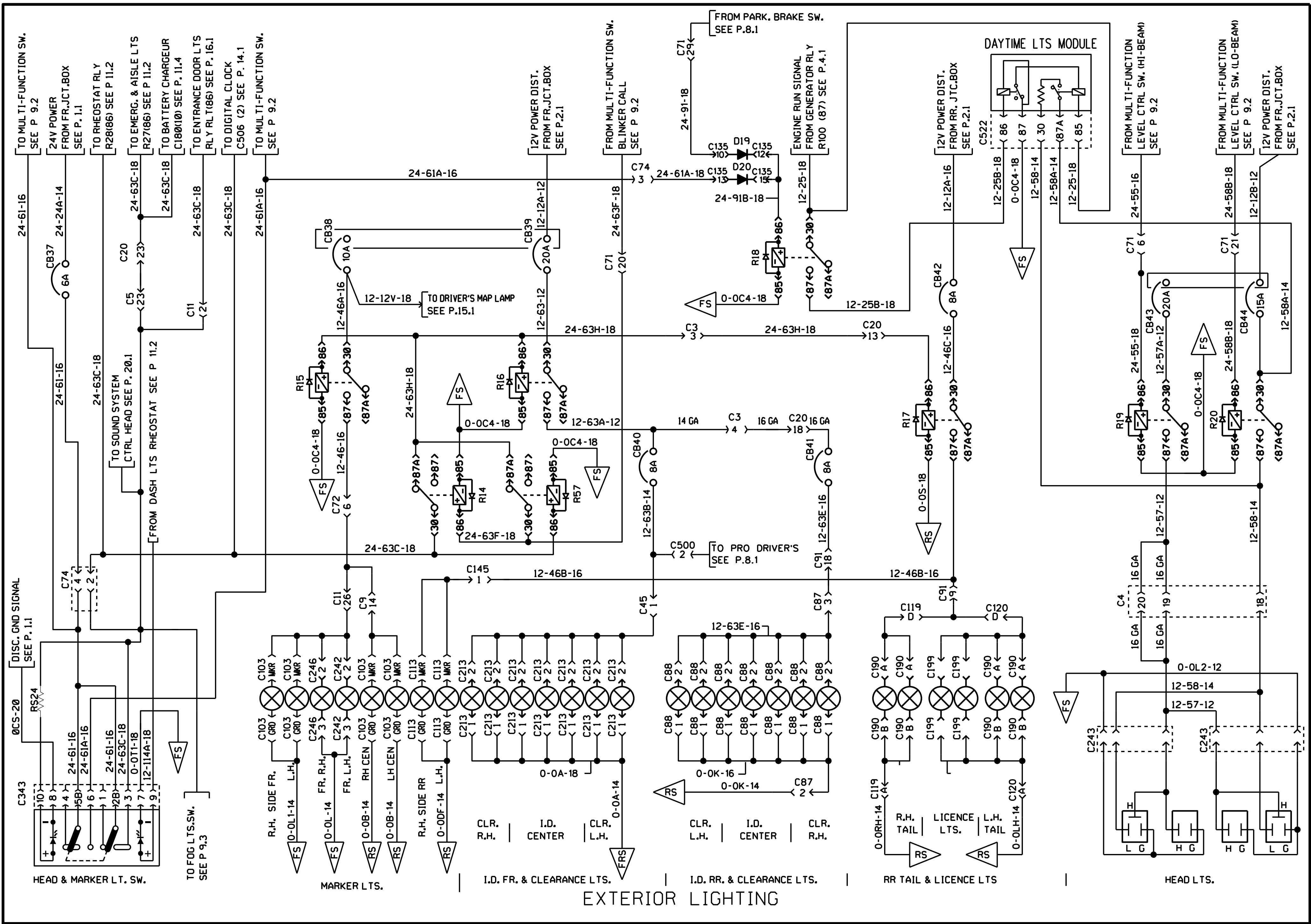

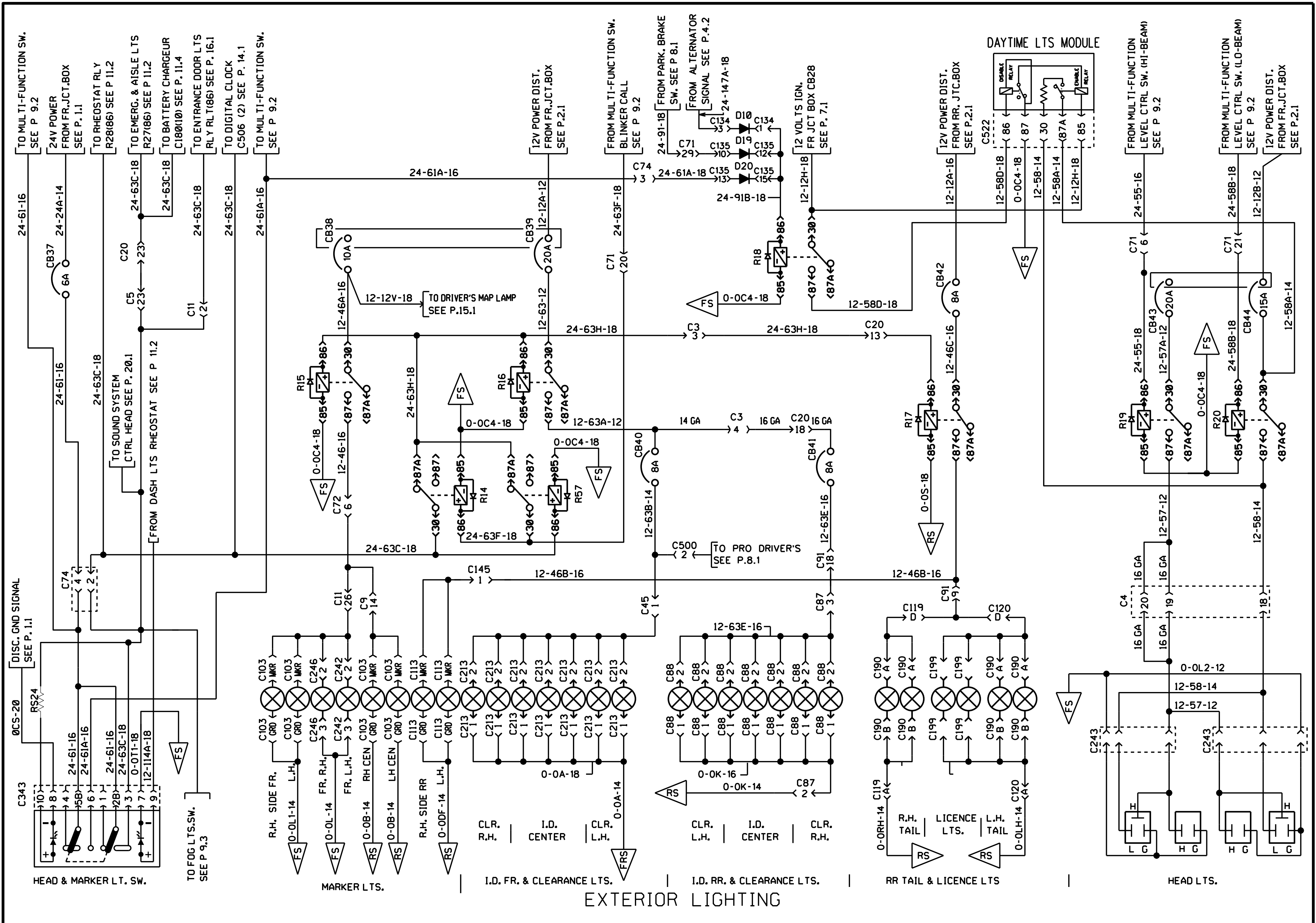

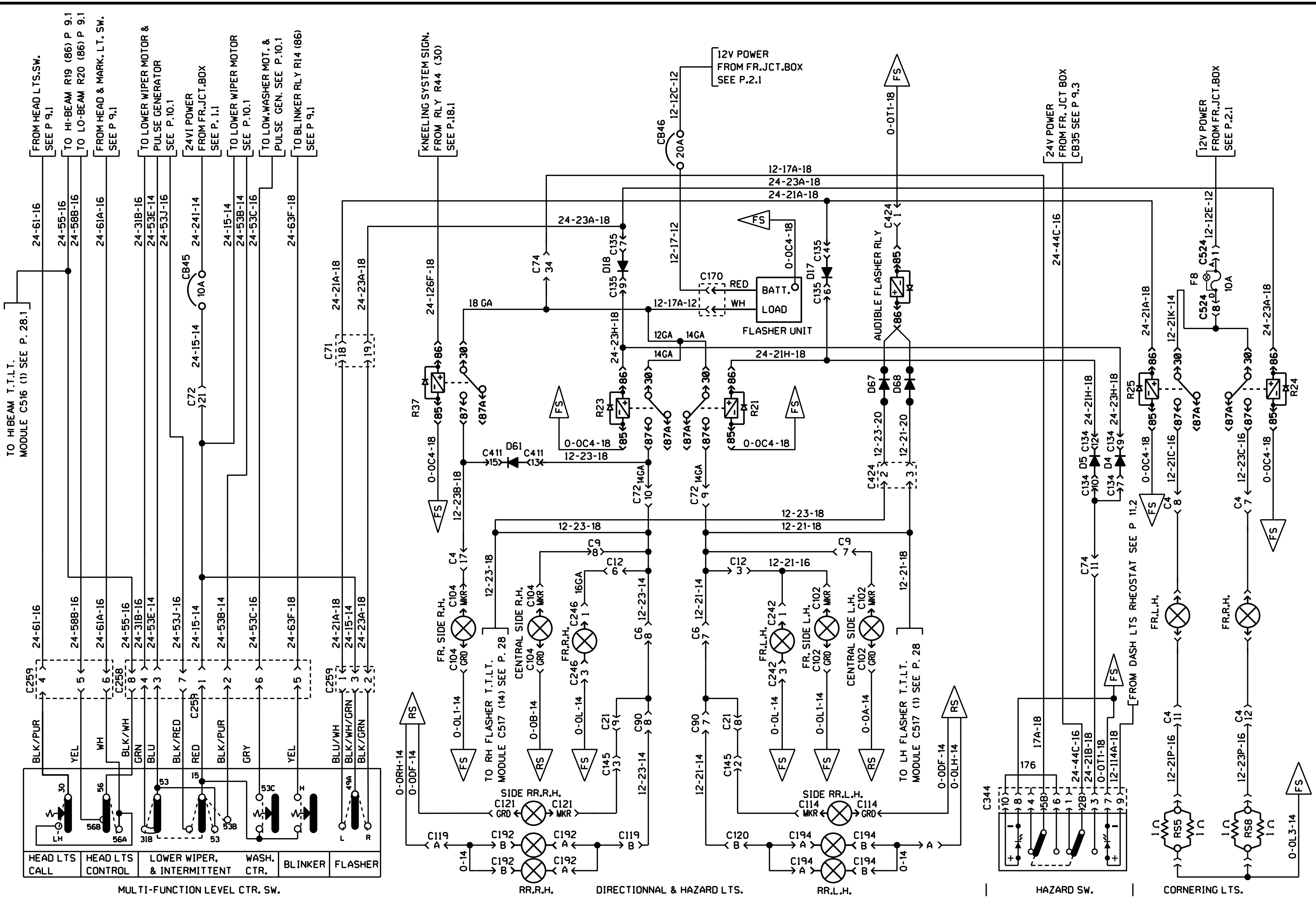

EXTERIOR LIGHTING



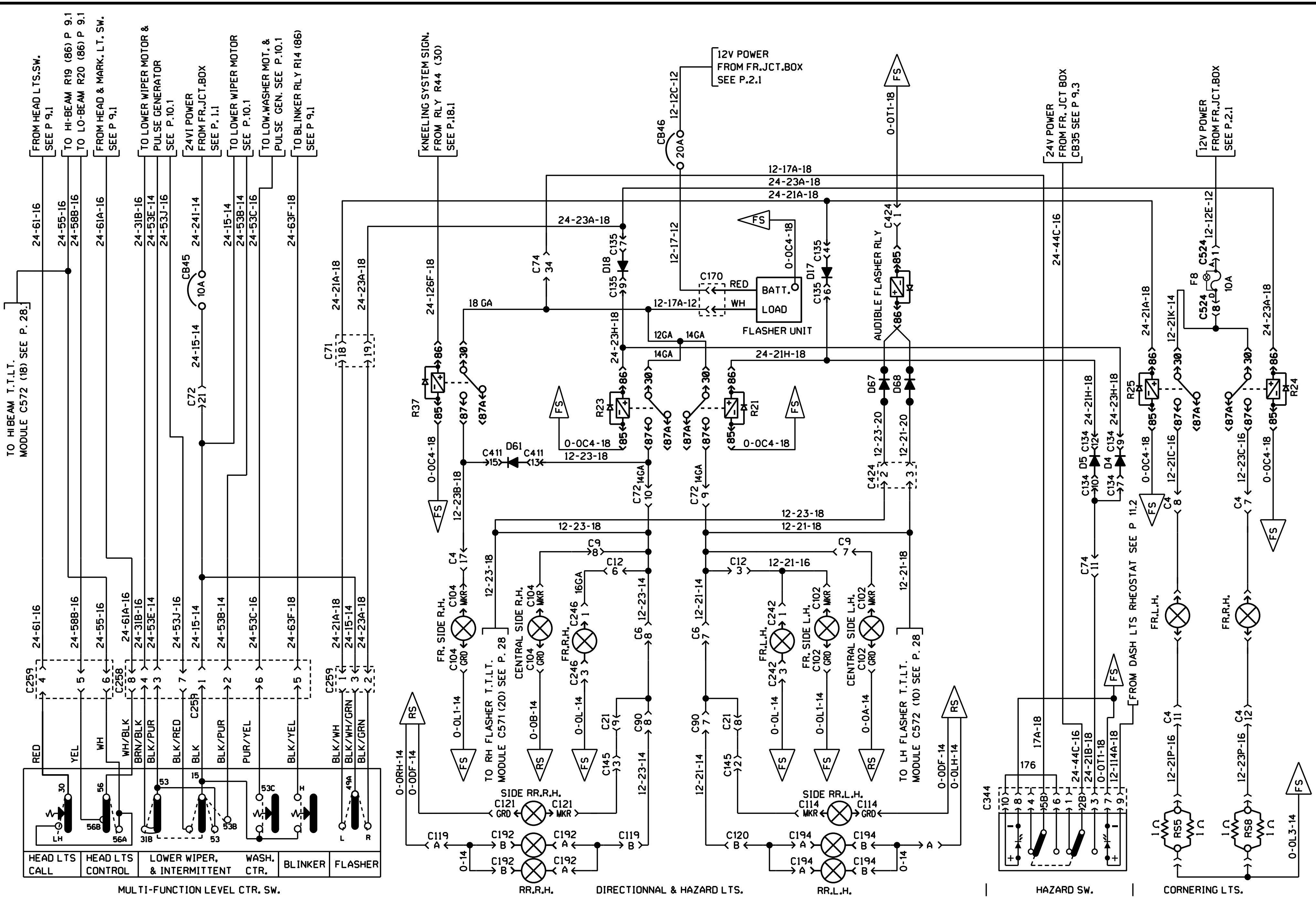

EXTERIOR LIGHTING

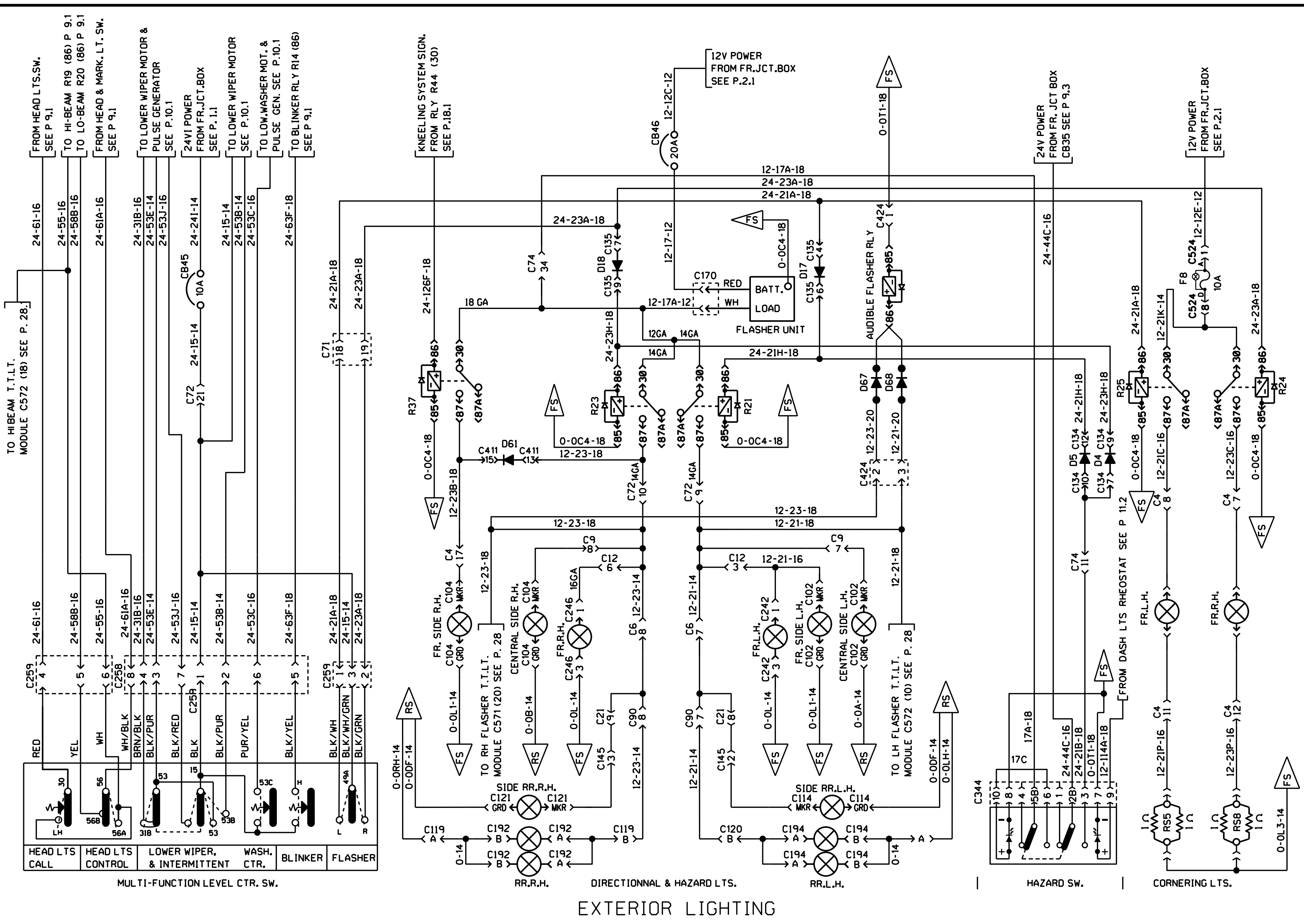

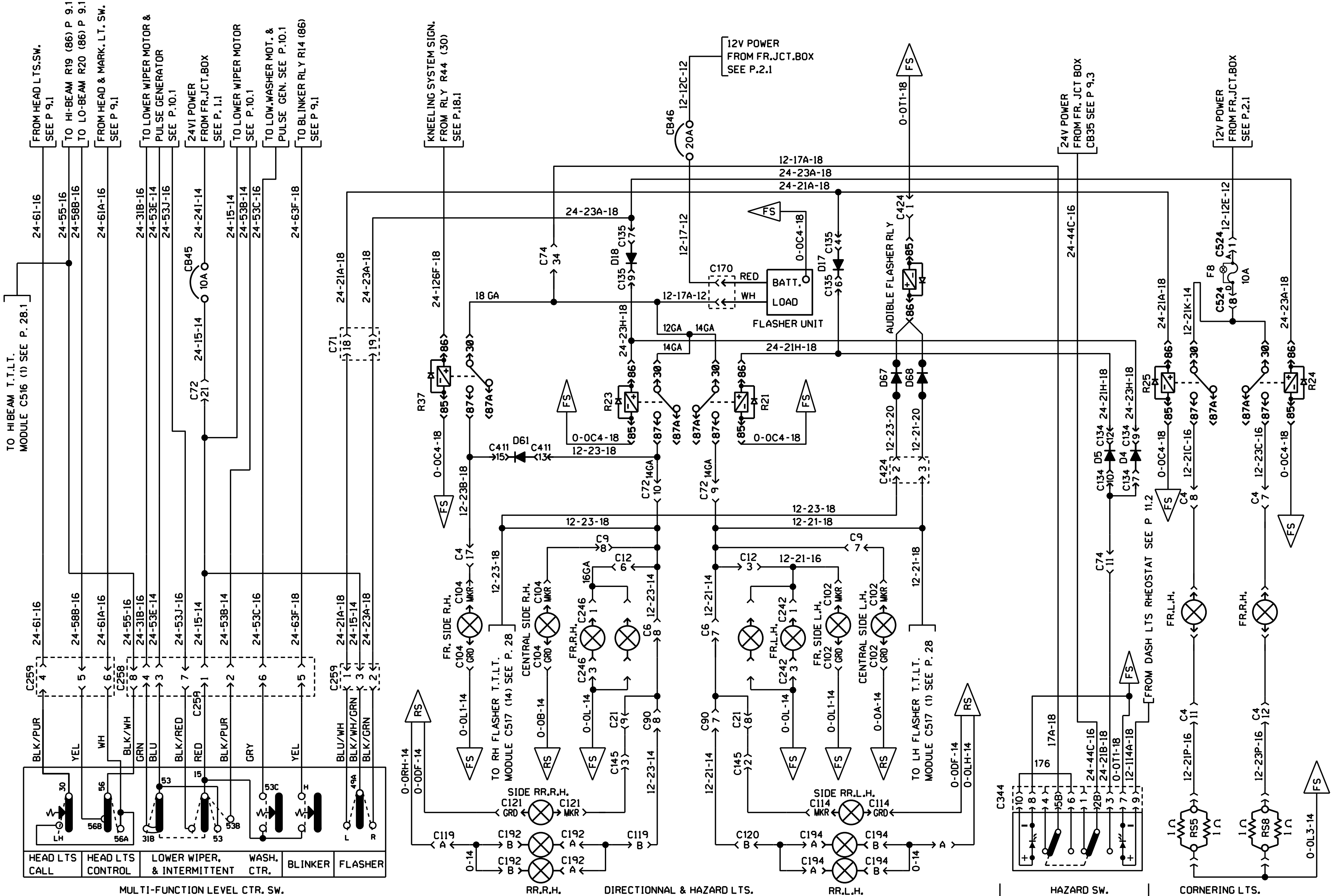

EXTERIOR LIGHTING



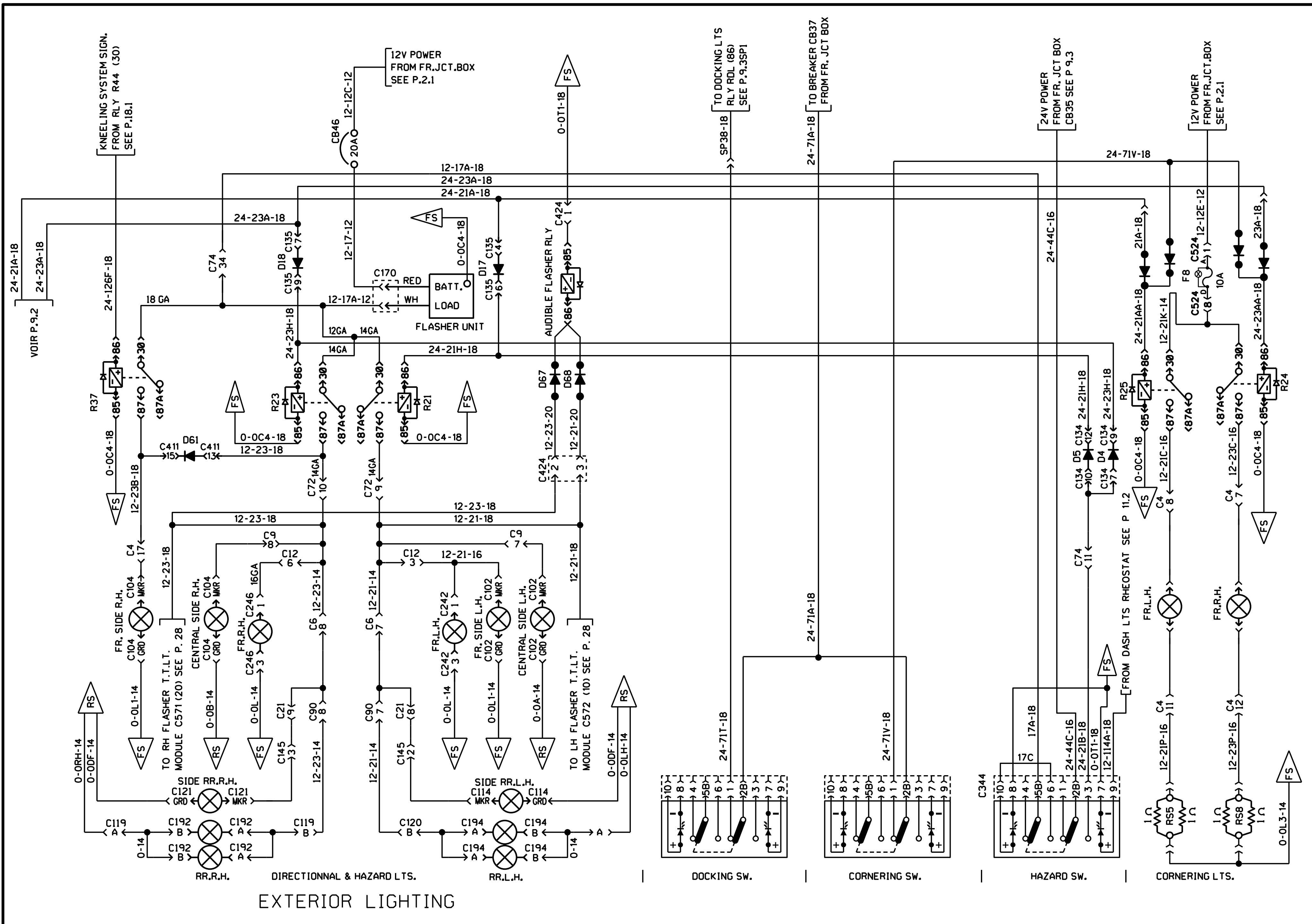

EXTERIOR LIGHTING

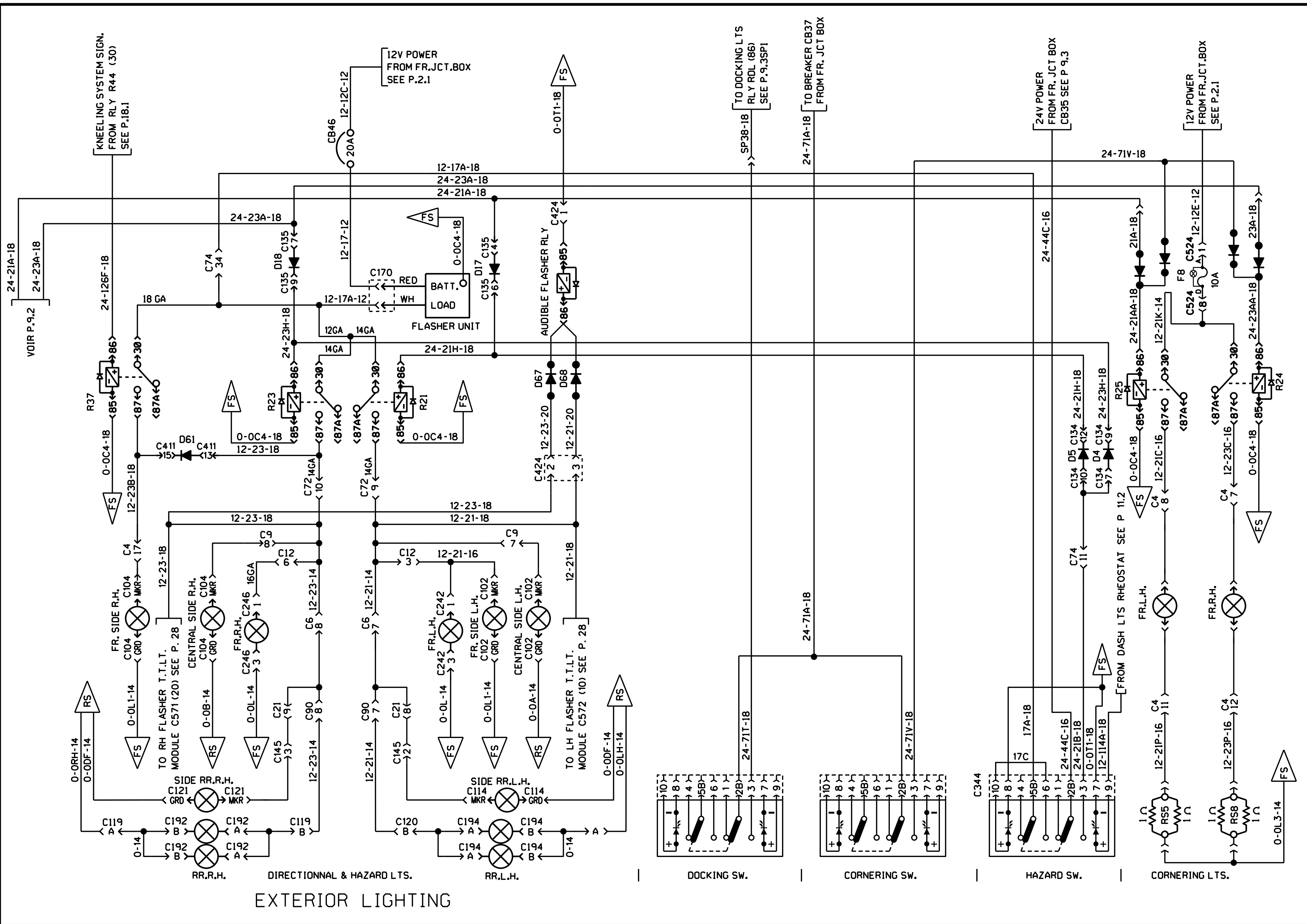

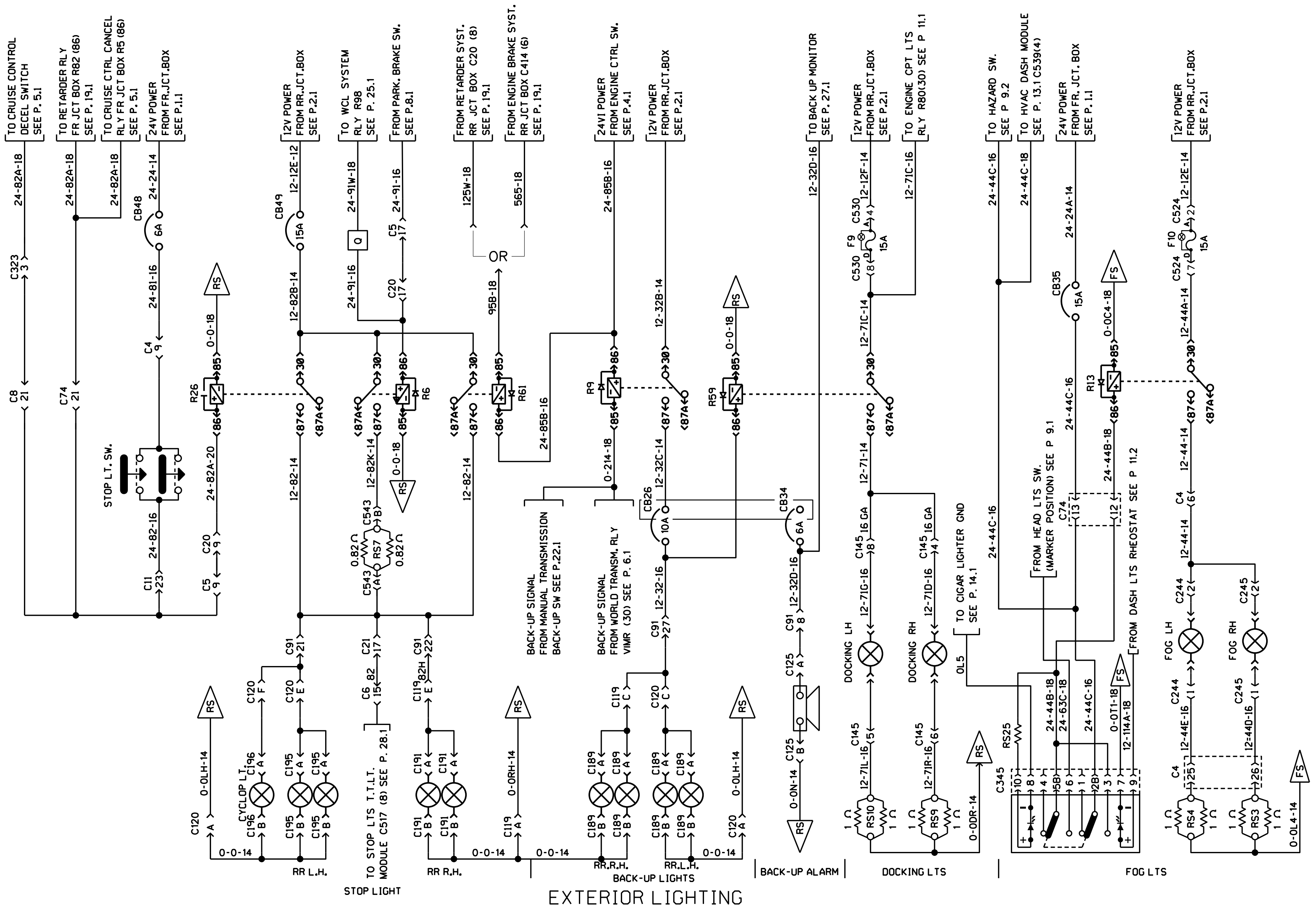





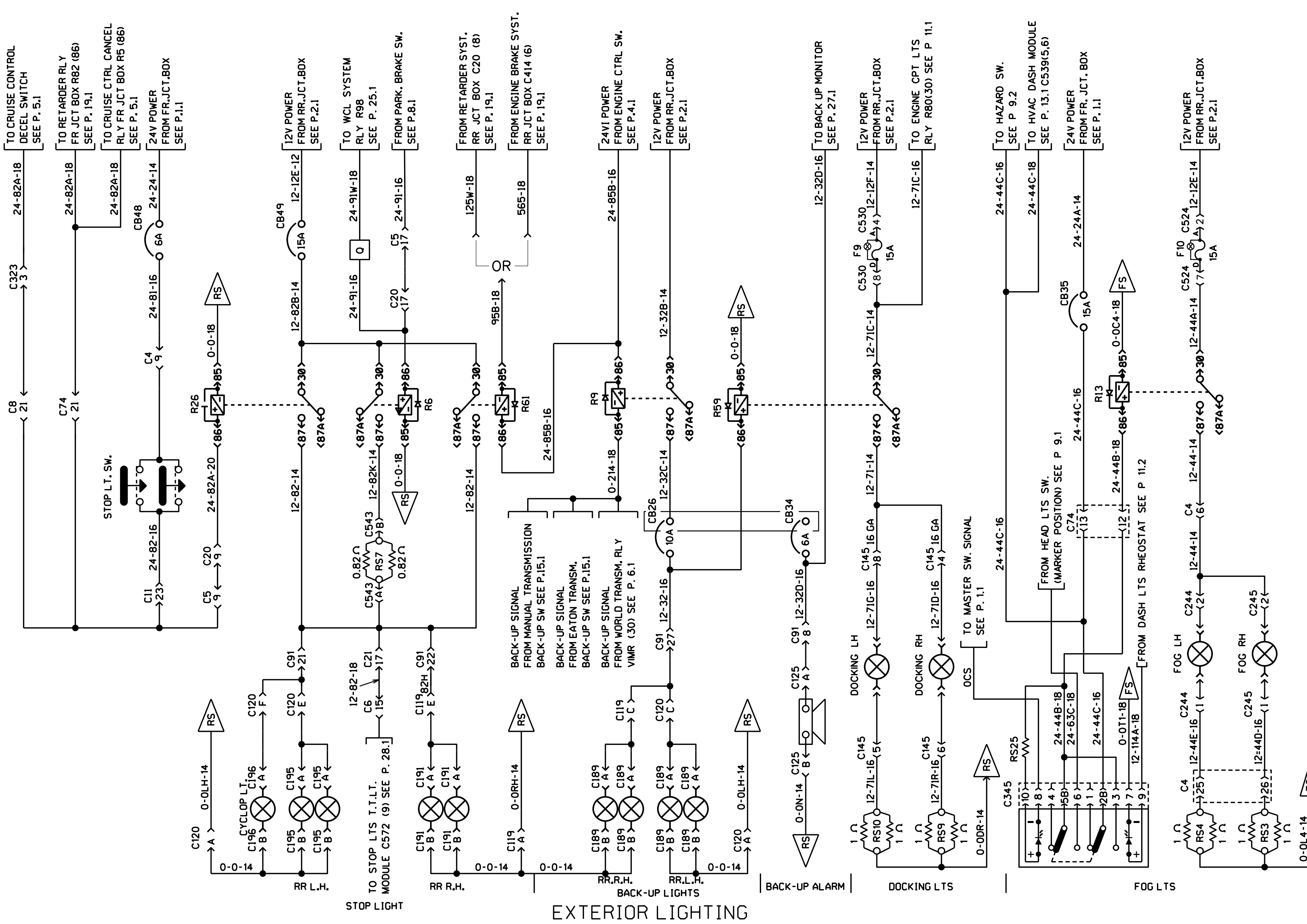

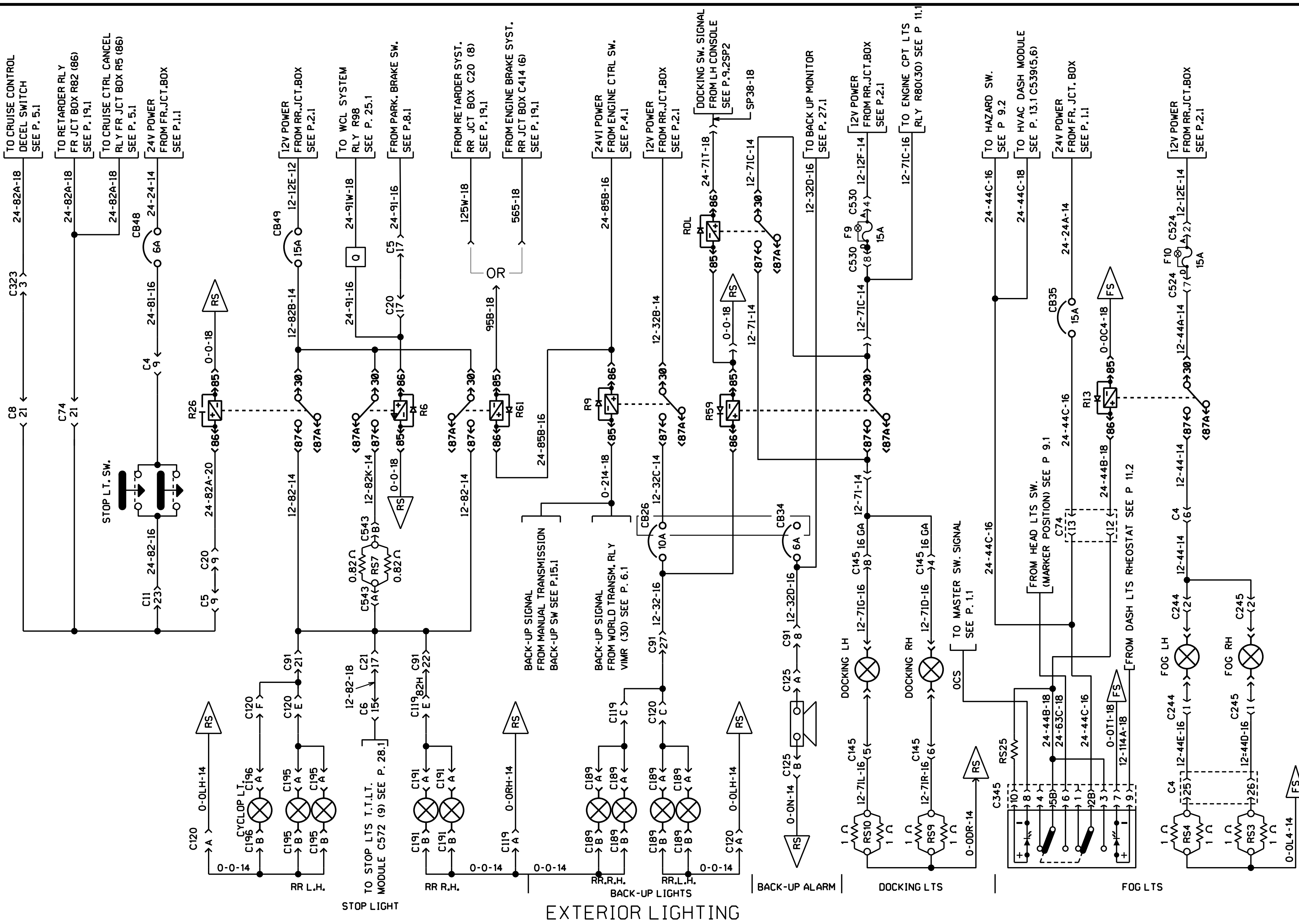

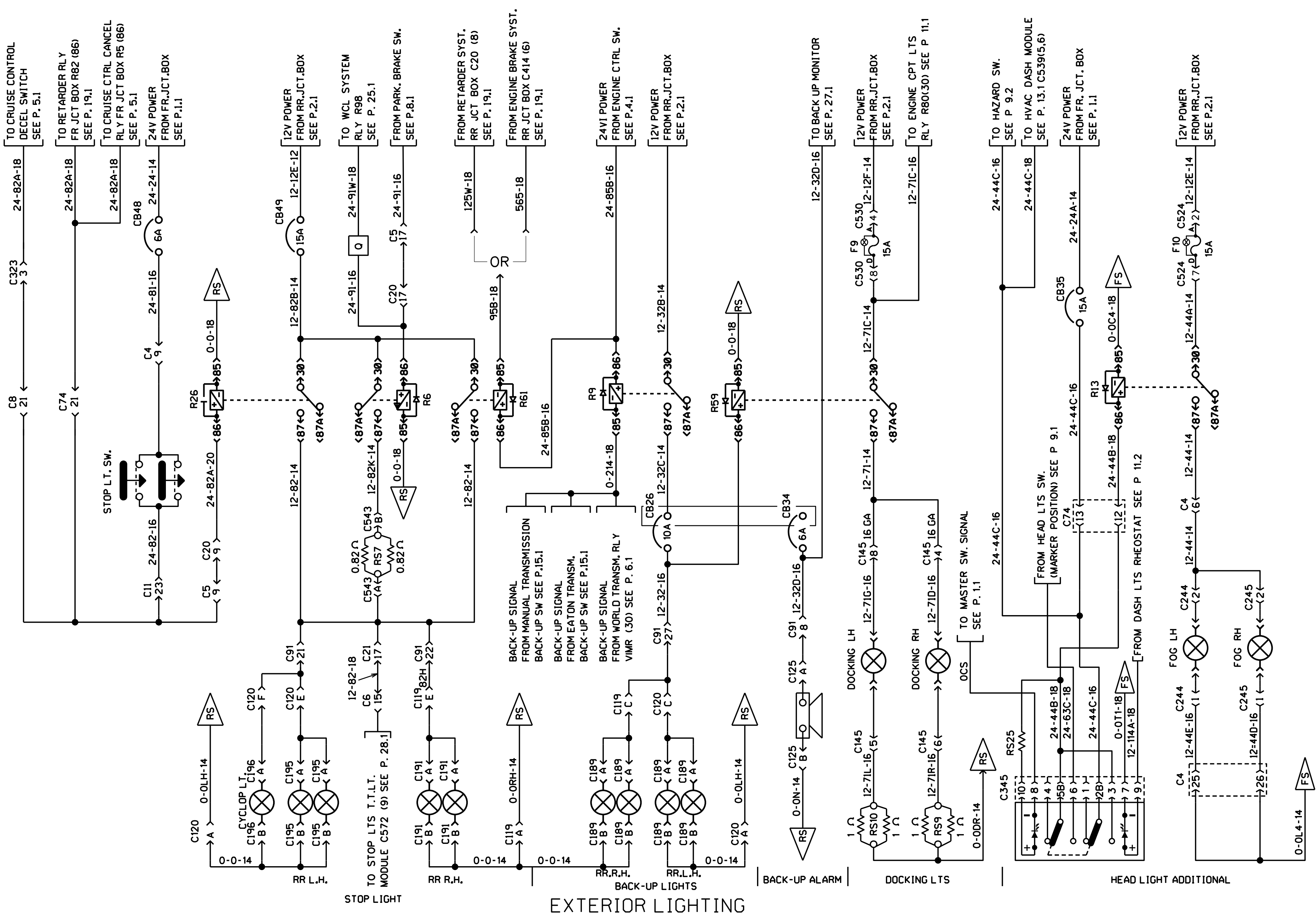

X3298 (LIMOCAR)

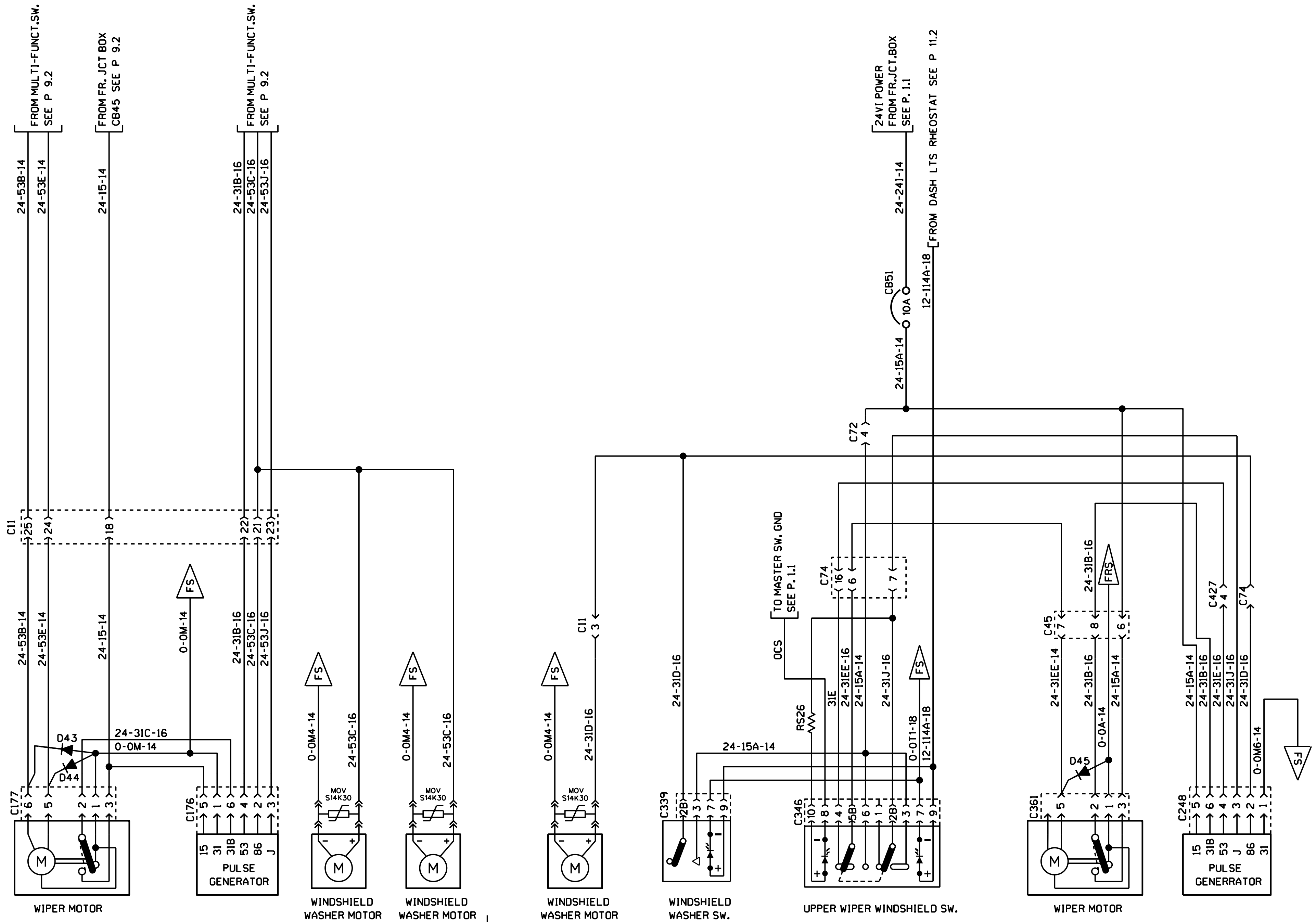

LOWER WINDSHIELD WIPER AND WASHER

UPPER WINDSHIELD WIPER AND WASHER

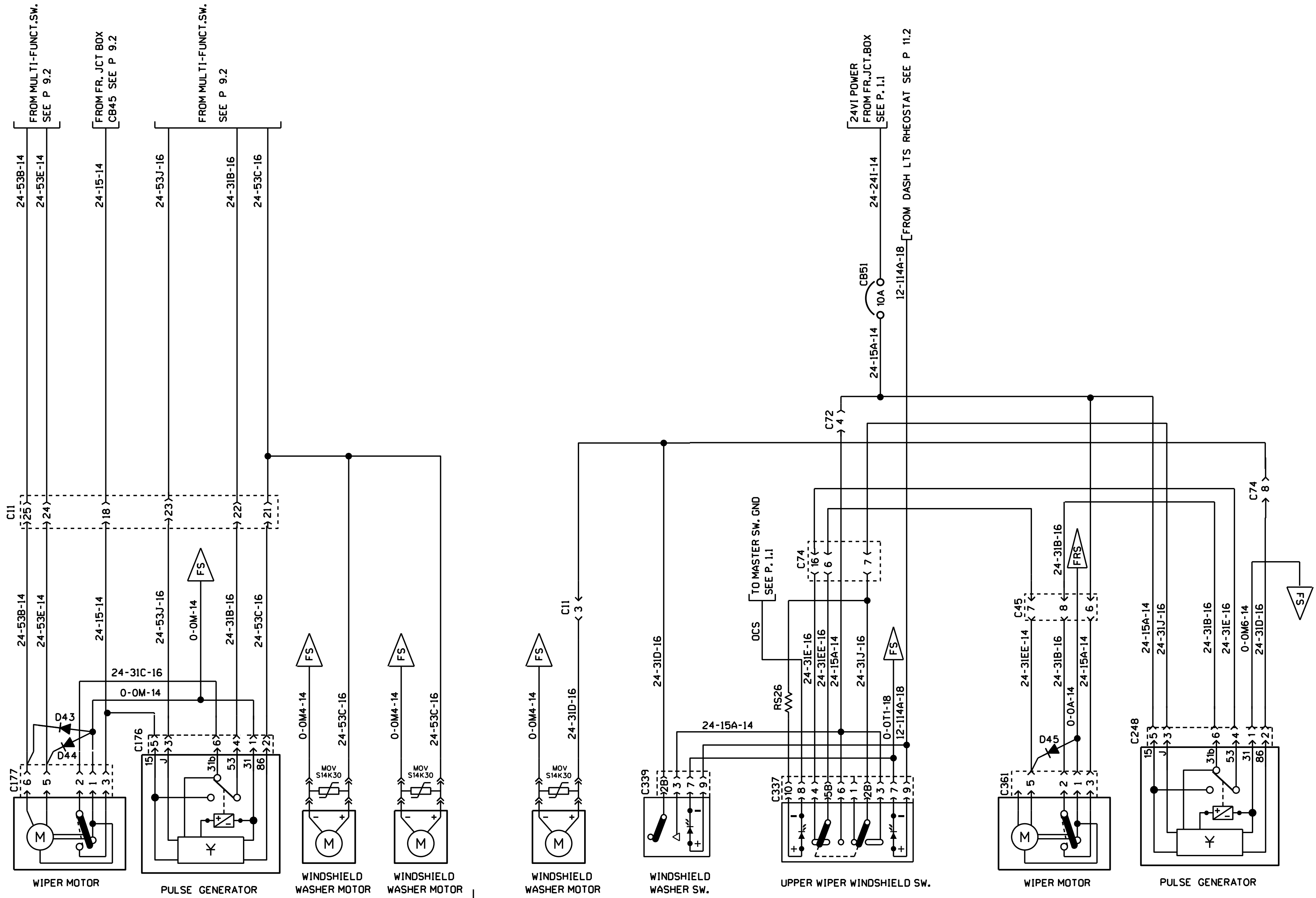

LOWER WINDSHIELD WIPER AND WASHER

UPPER WINDSHIELD WIPER AND WASHER

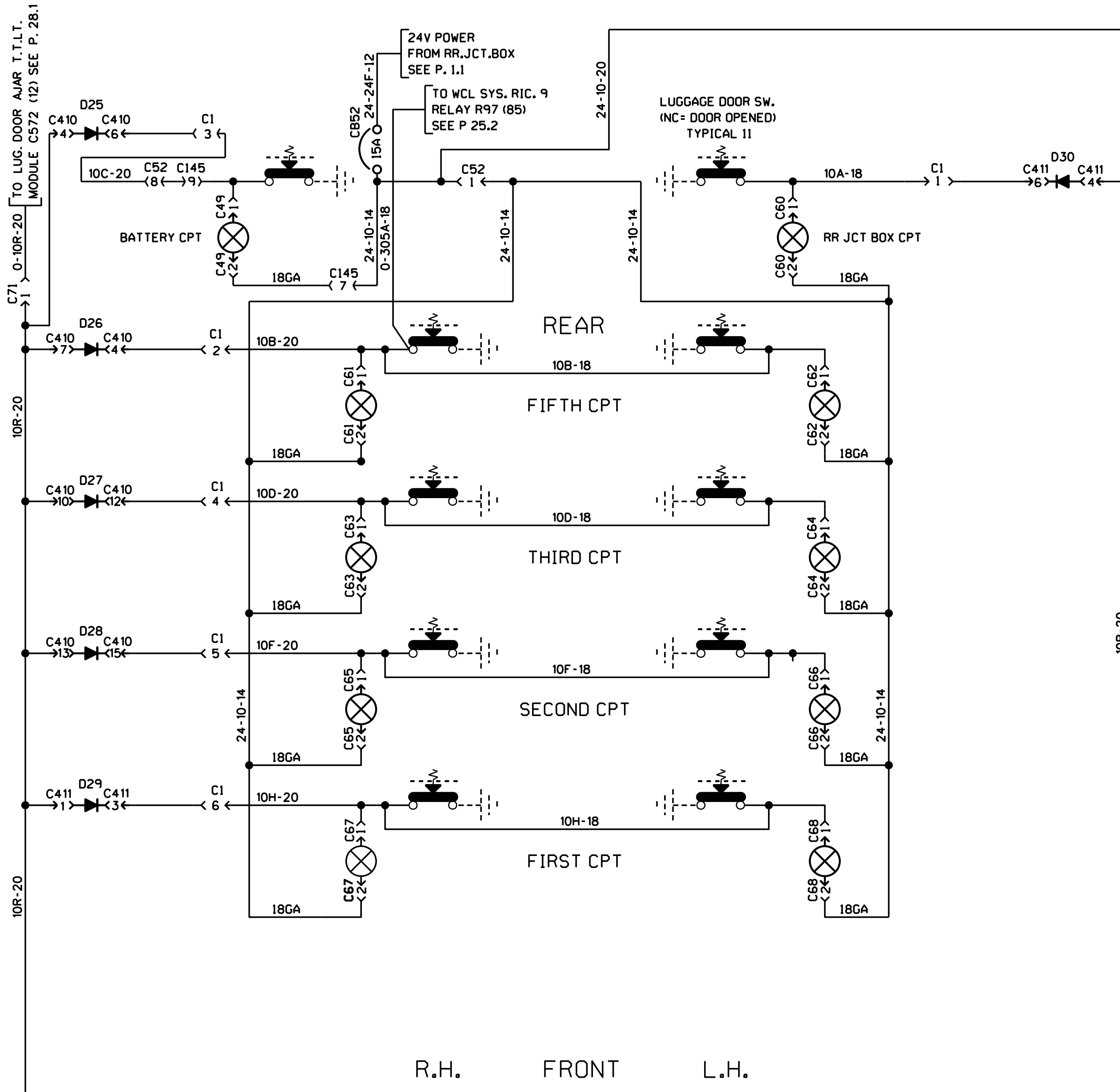

LUGGAGE COMPARTMENT AND DOOR AJAR LTS

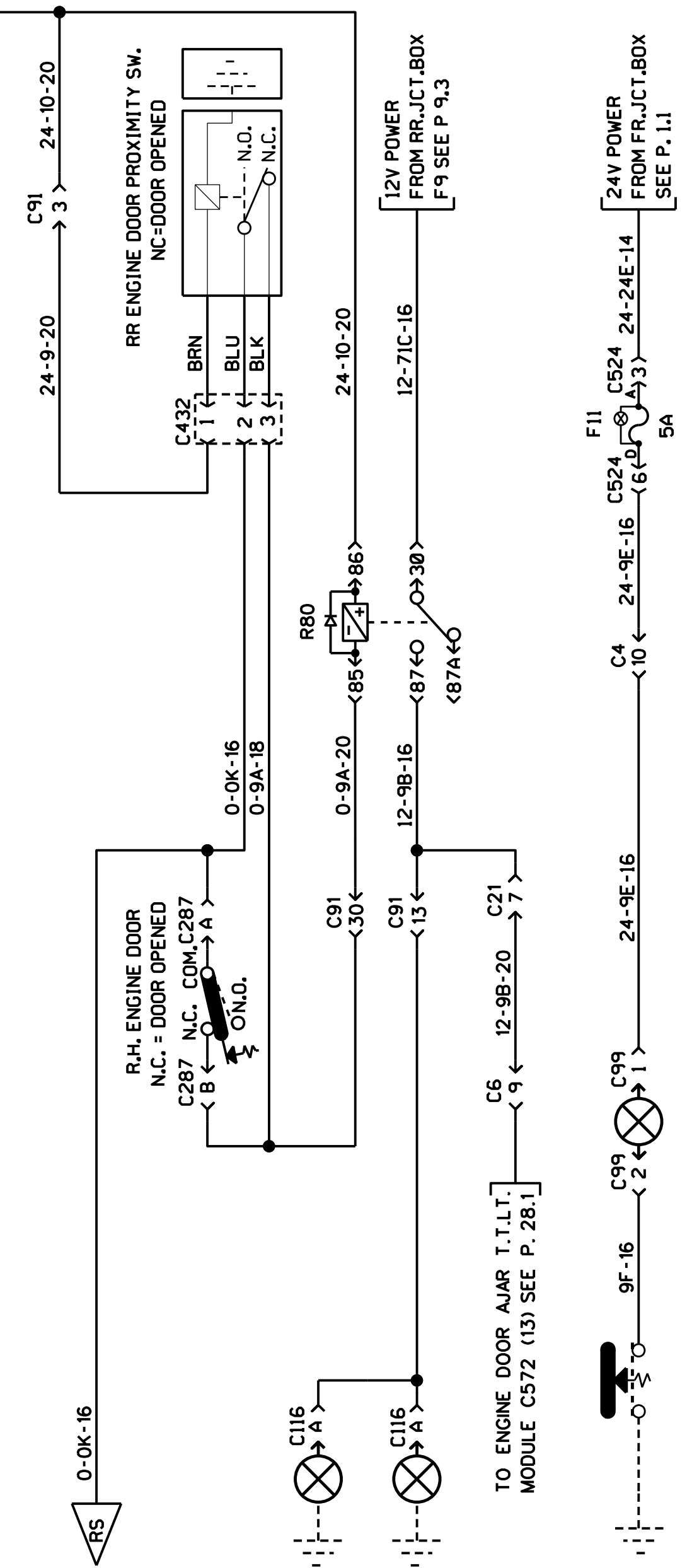

ENGINE COMPT. LTS.

FRONT SEVICE COMPT. LT.

INTERIOR LIGHTING



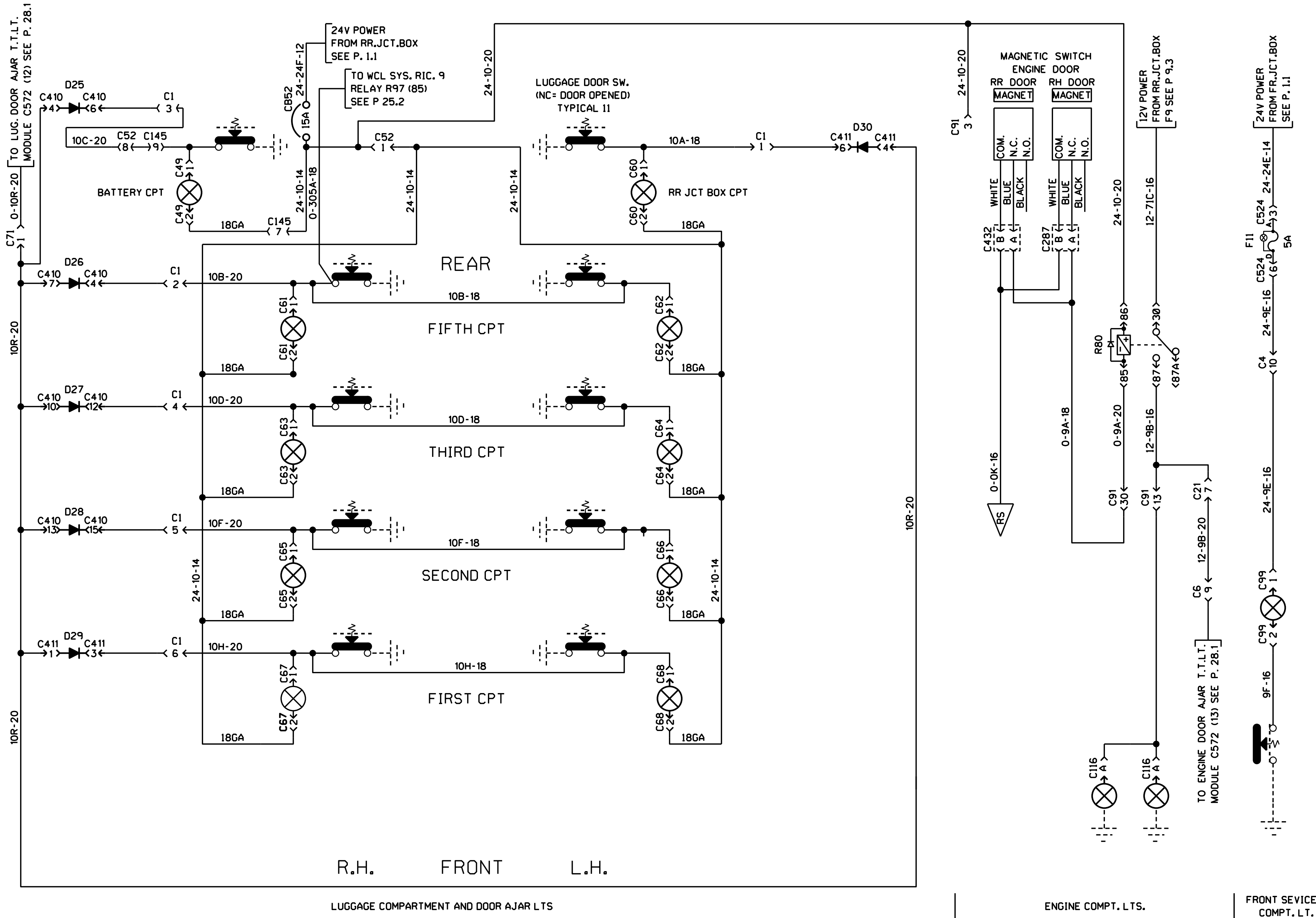

INTERIOR LIGHTING

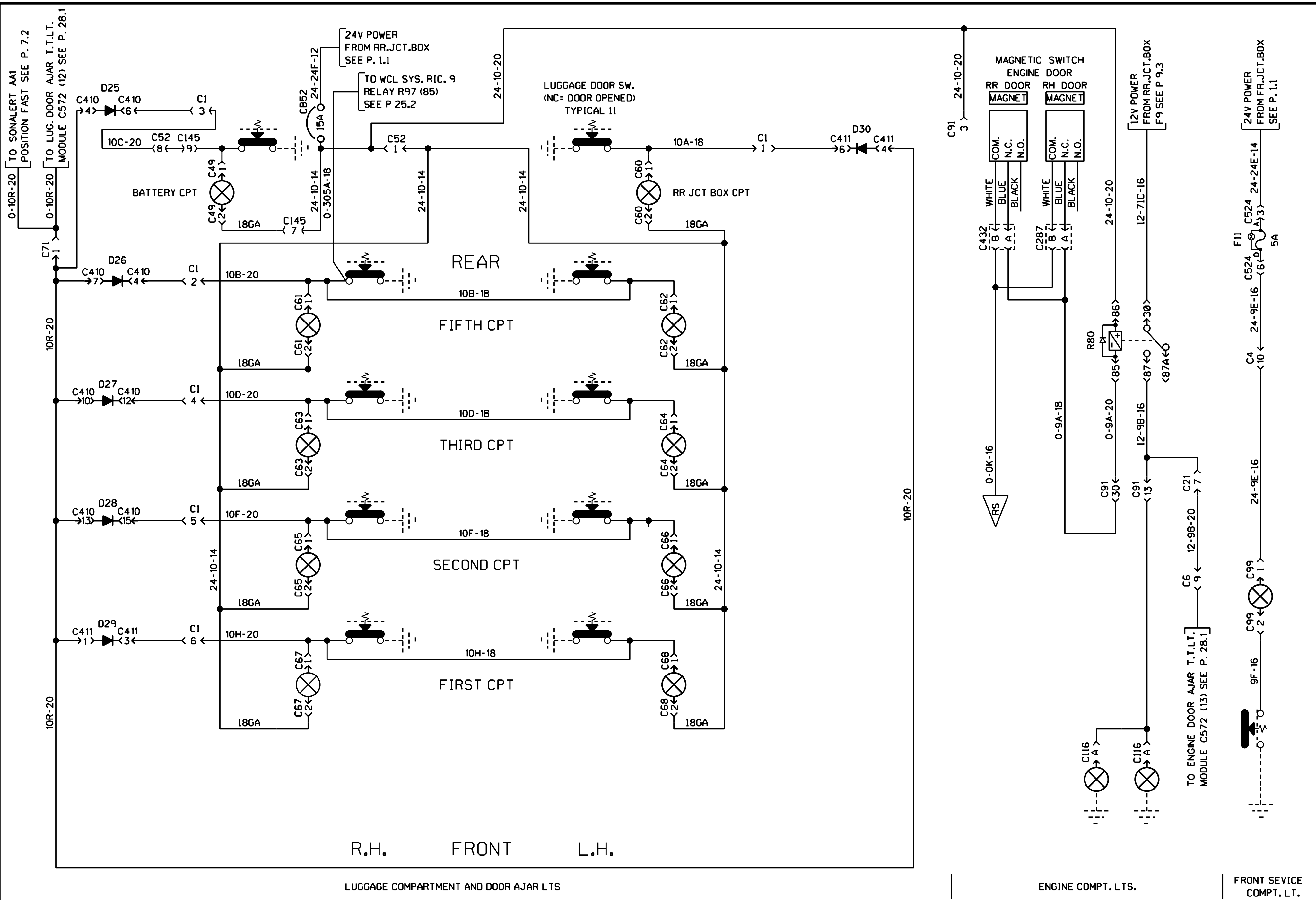



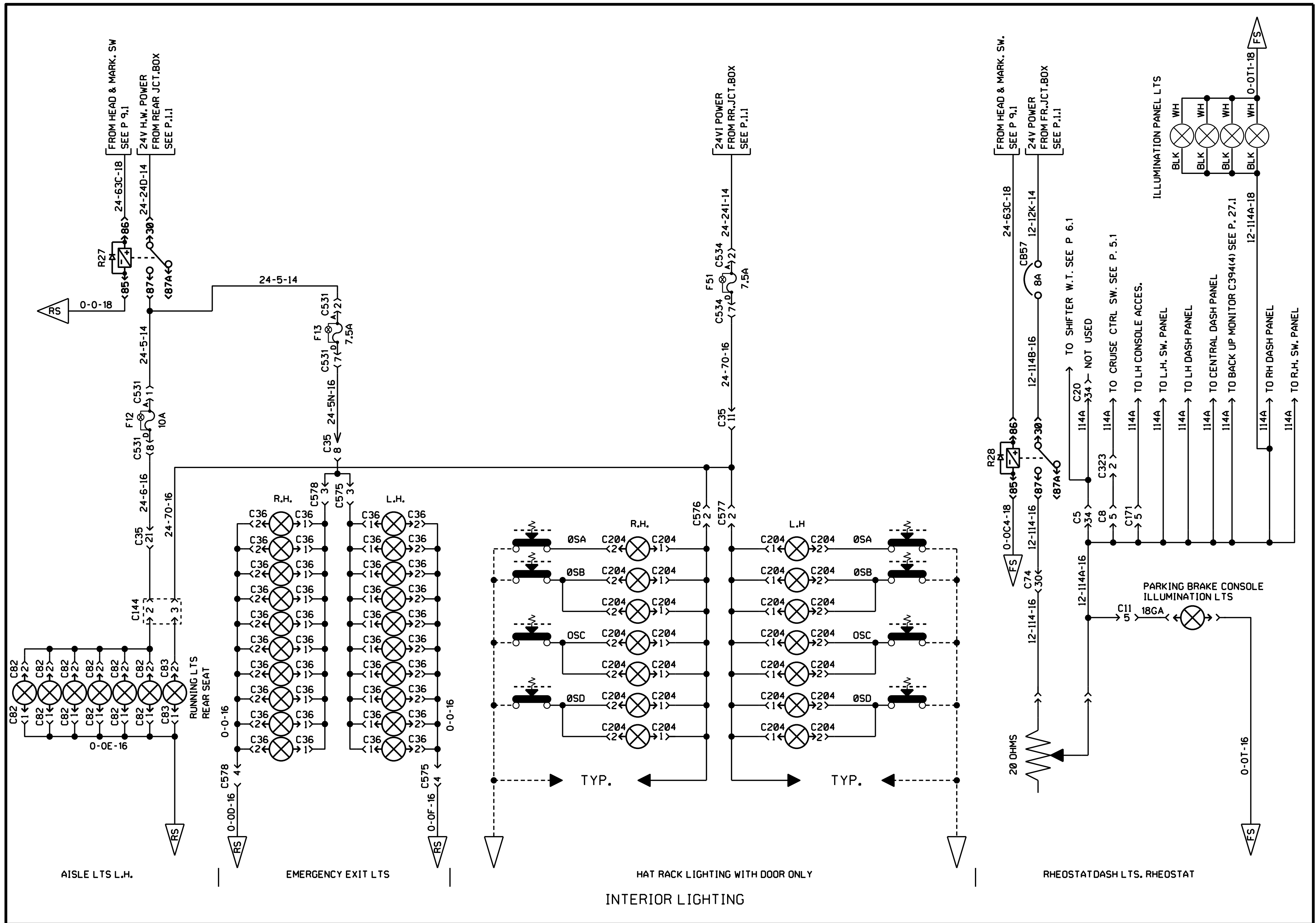

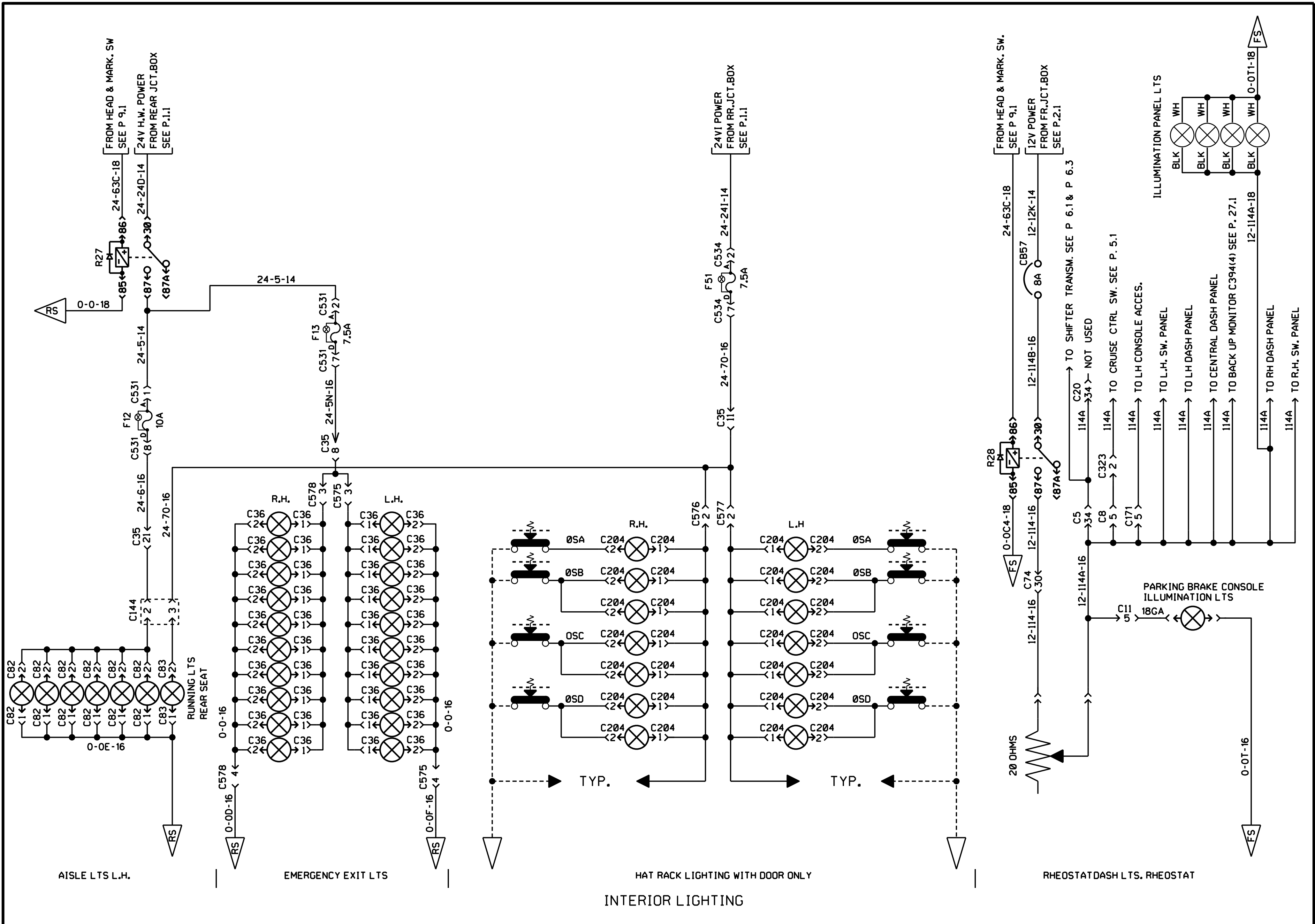

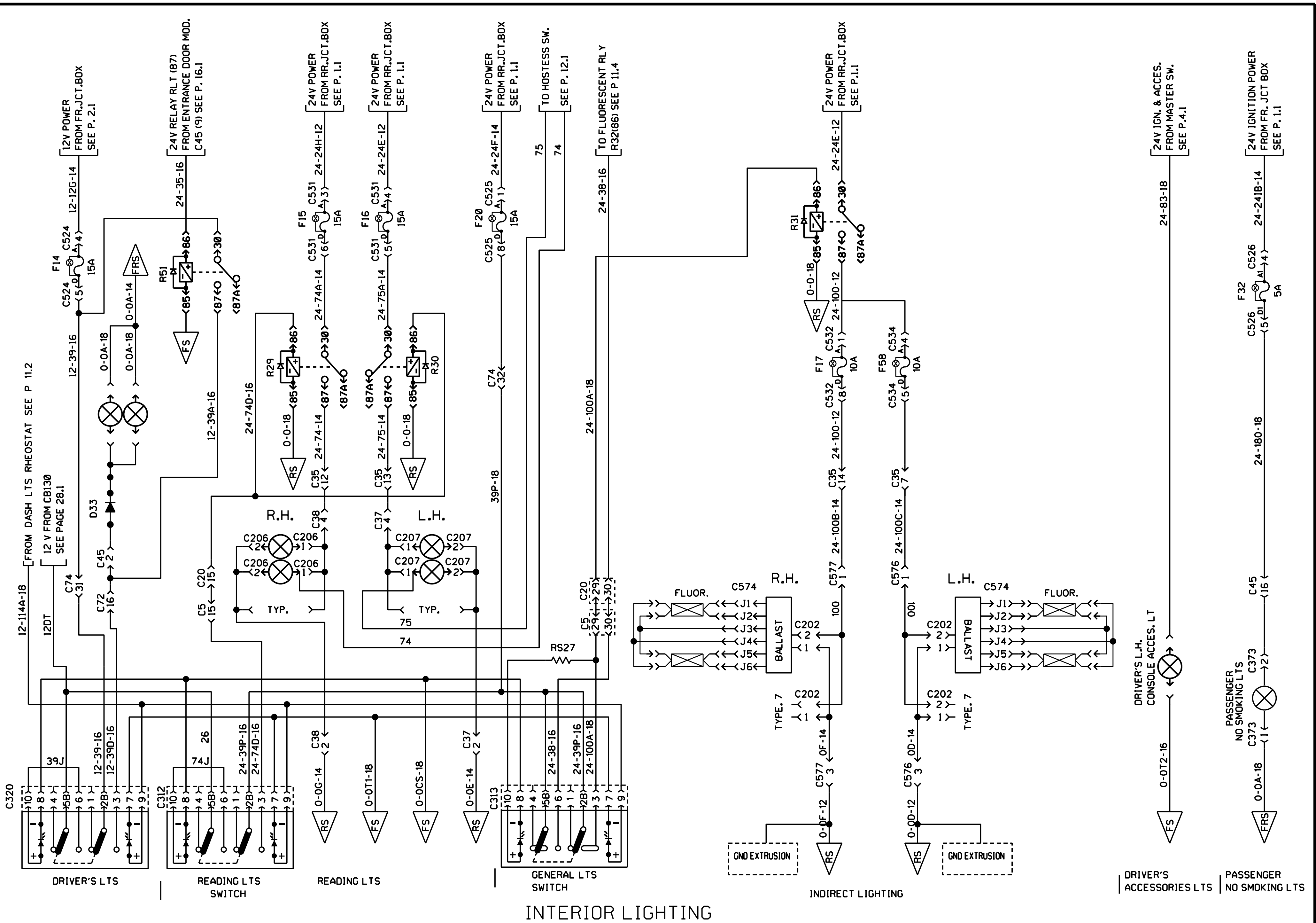

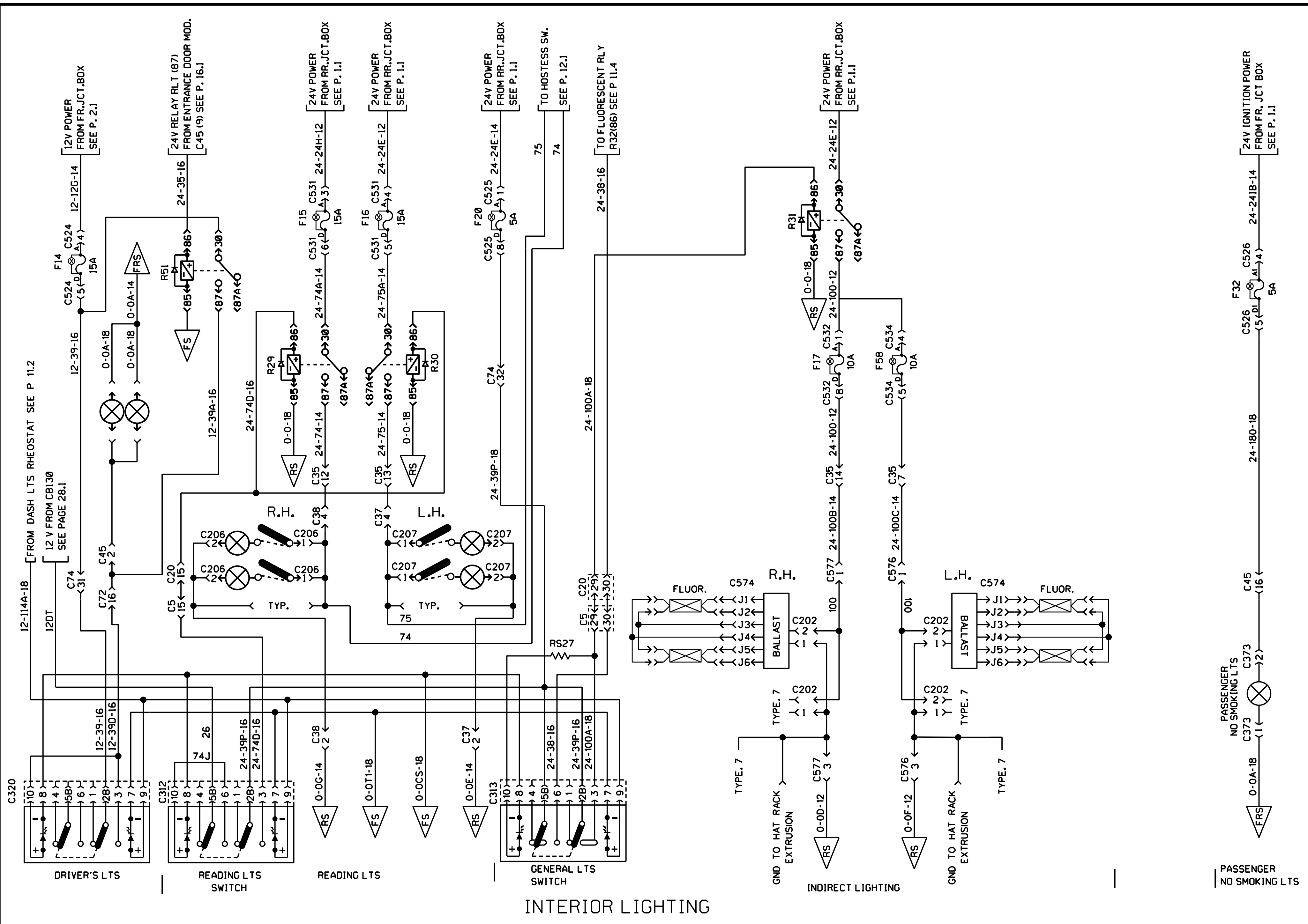

INTERIOR LIGHTING



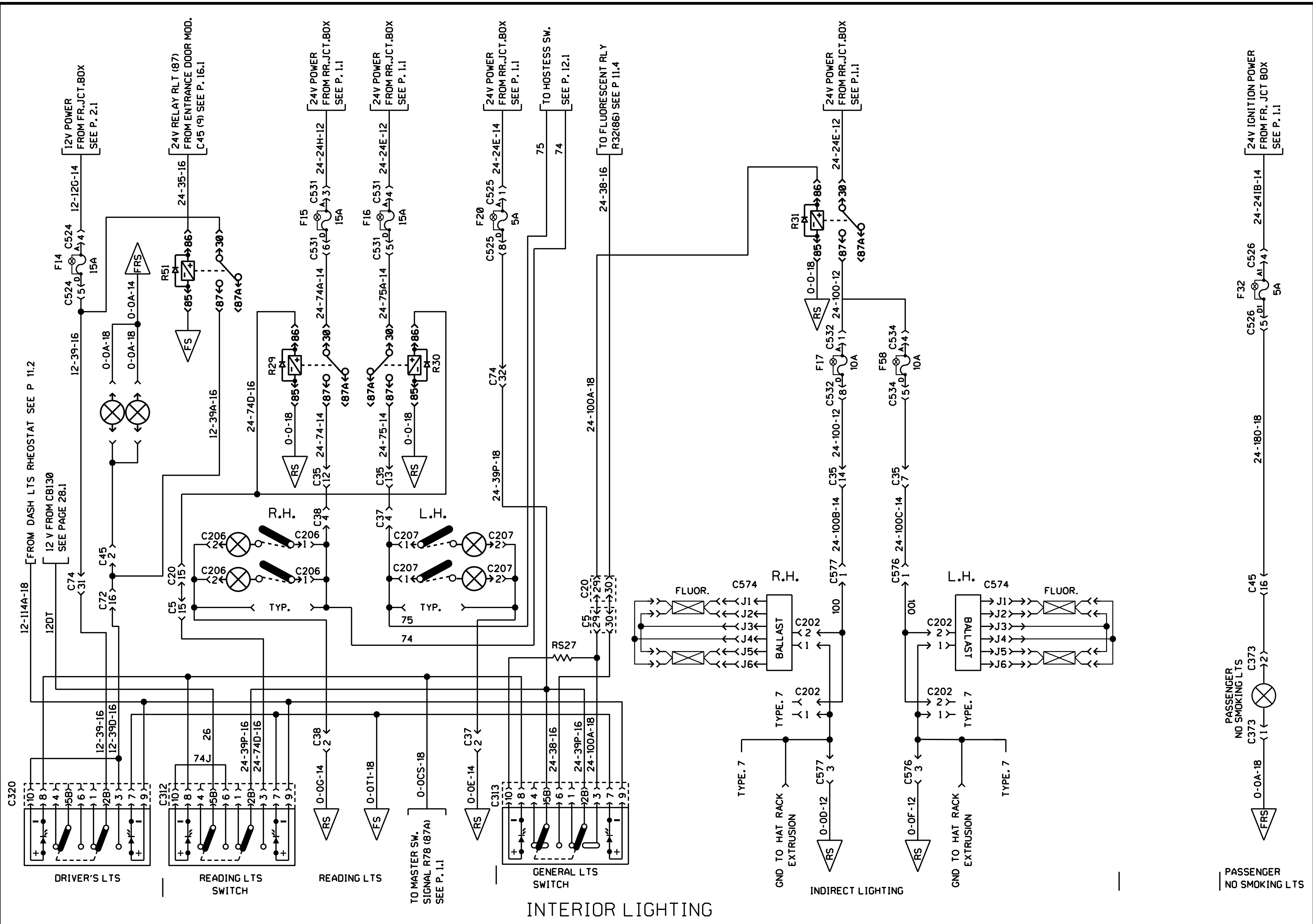

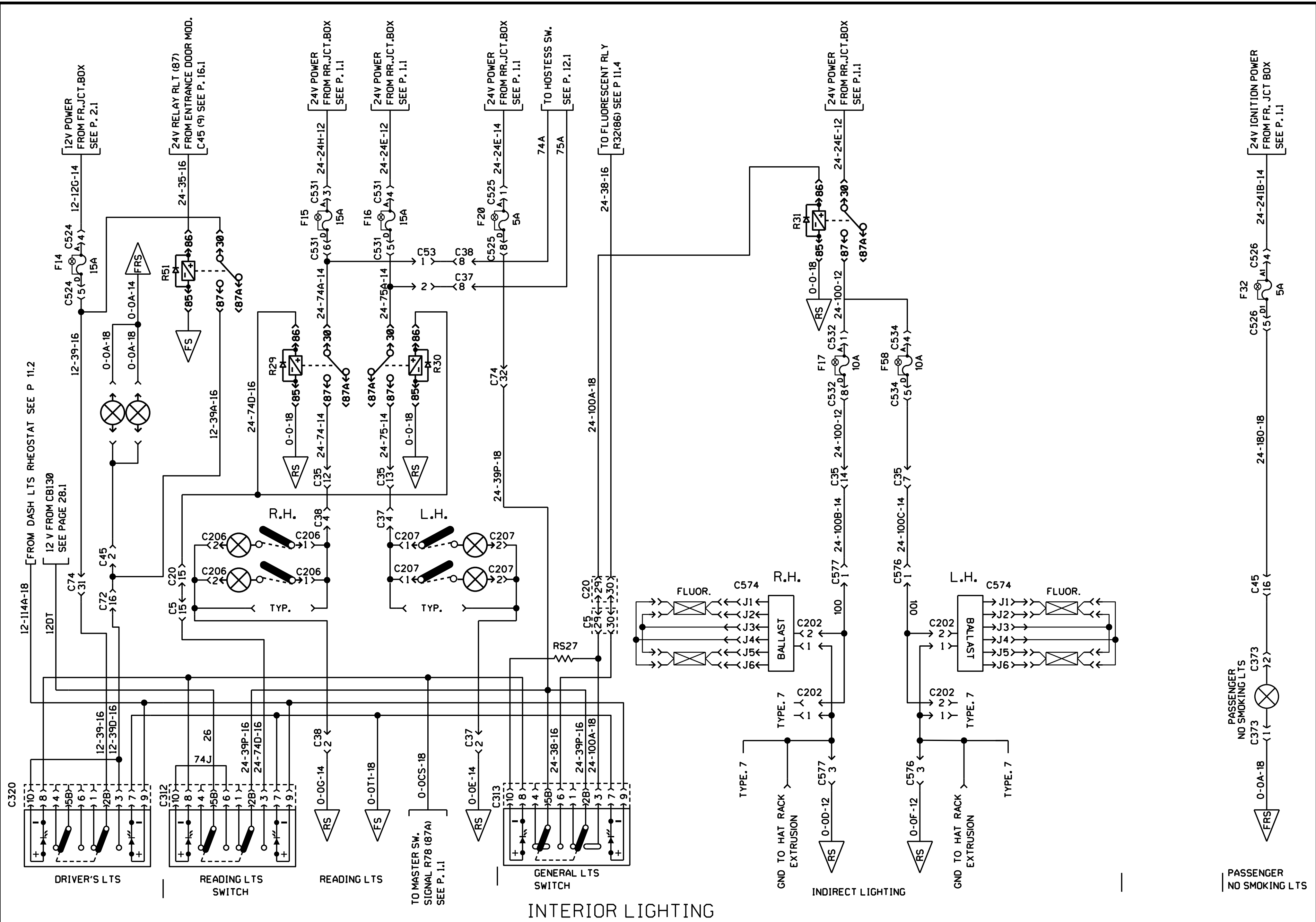

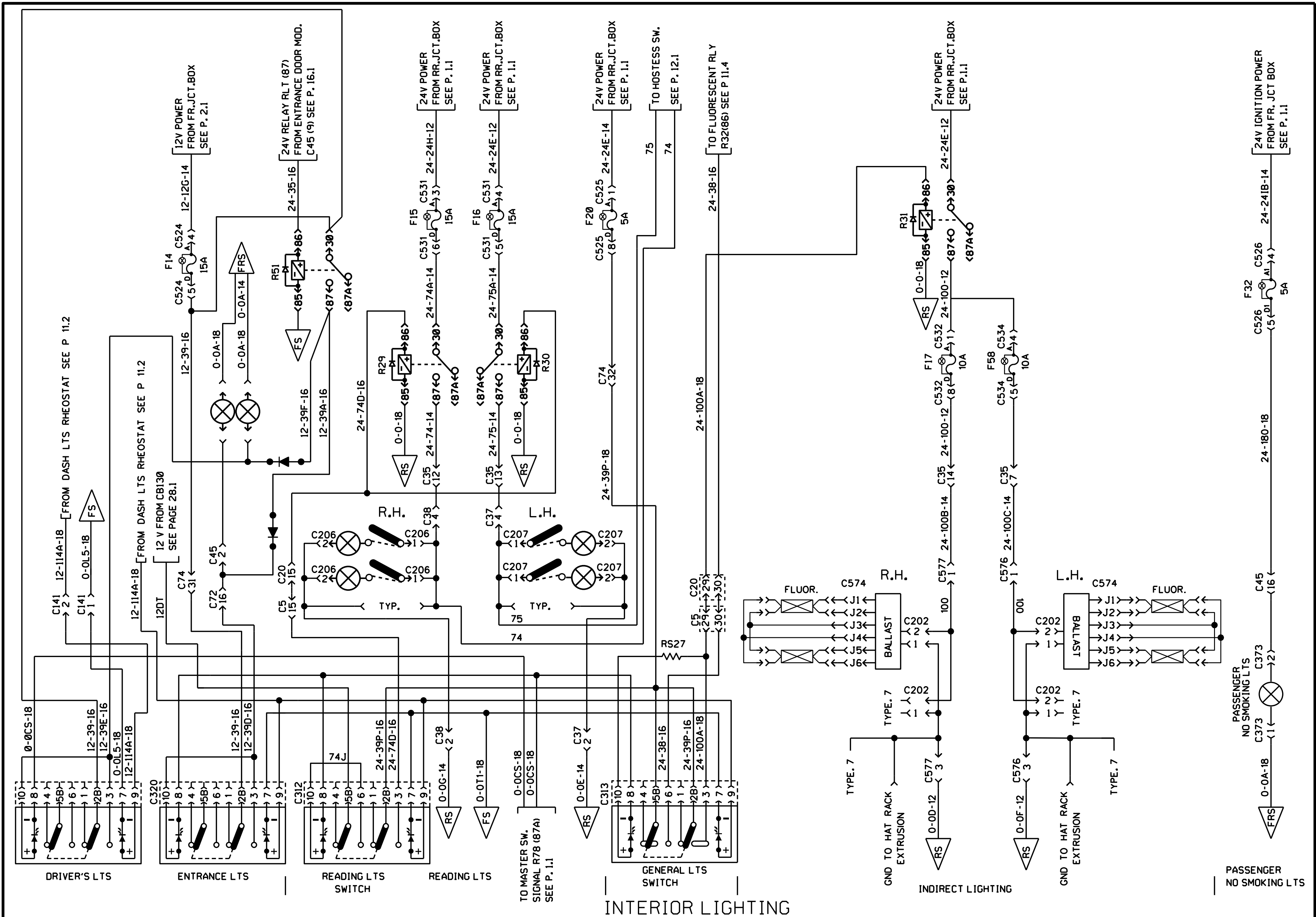

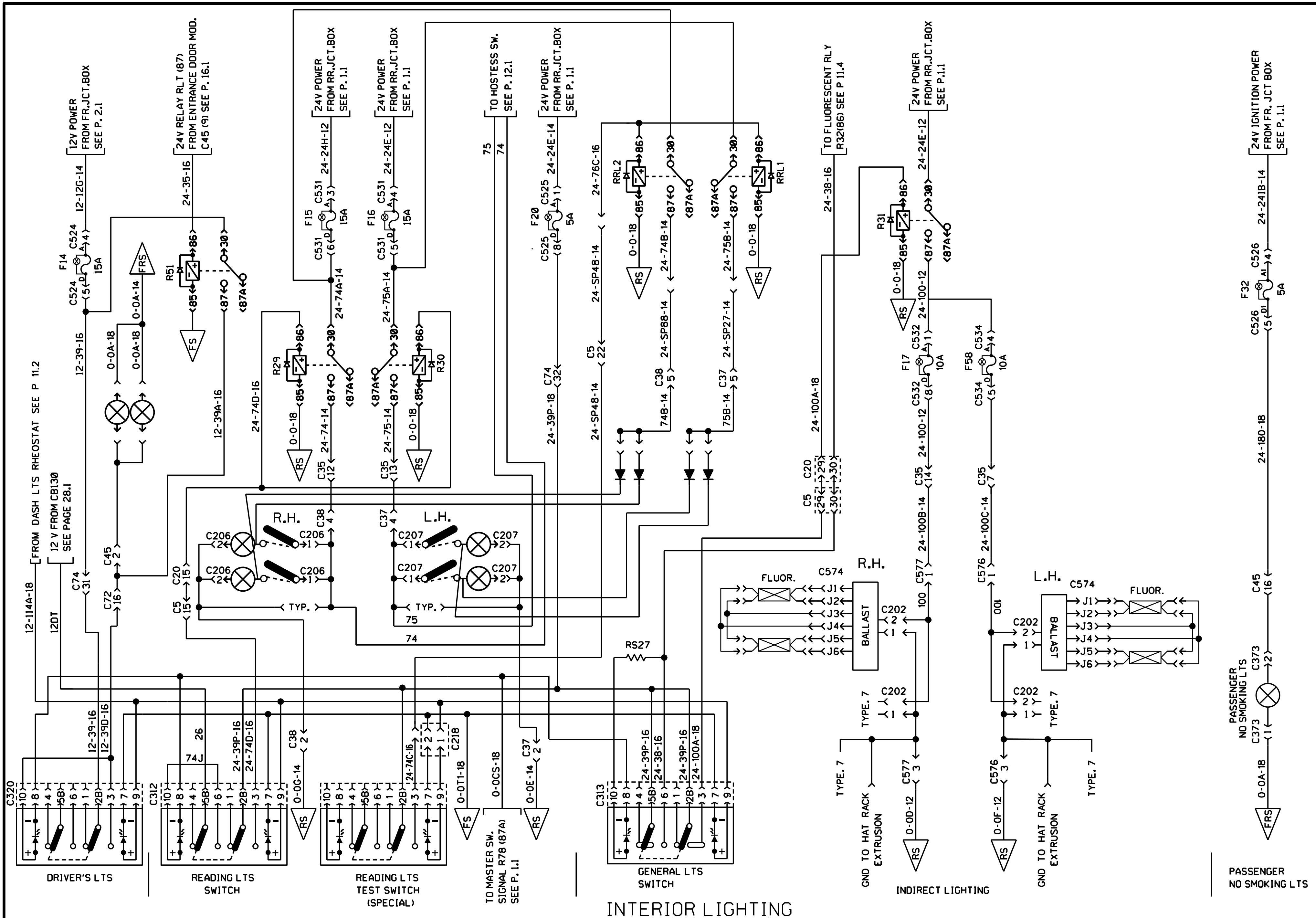

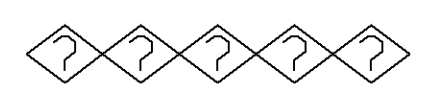
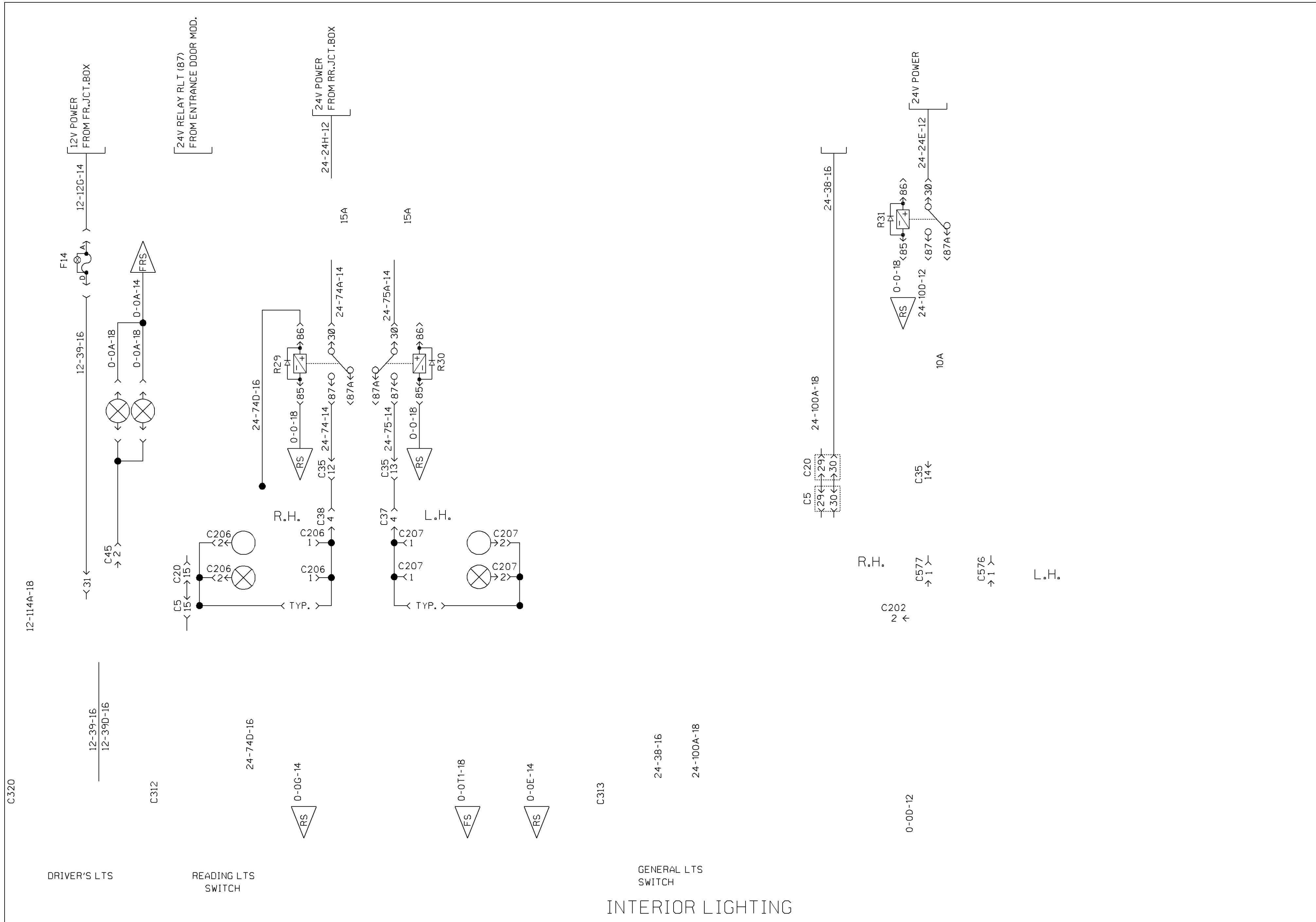

NO: D060902

PLUG 110V

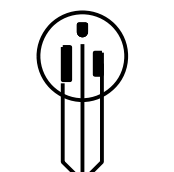

C180 D36 C180 83 FROM ACCESSORIES SEE P. 4.1  
D37  
D38  
63C FROM MARKERS LTS SEE P. 9.1

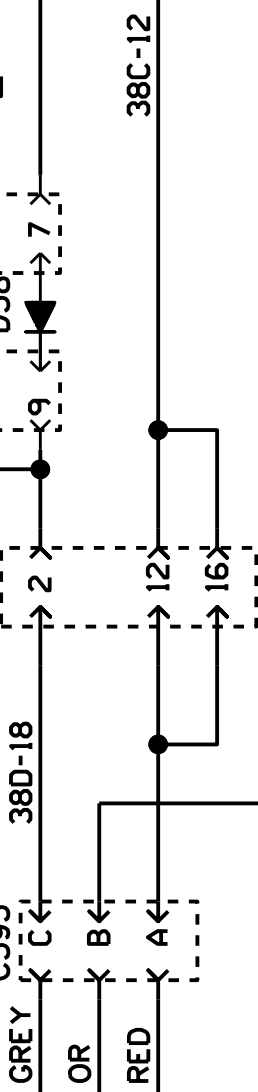

TO BATTERY SEE PAGE 1.2

24BC

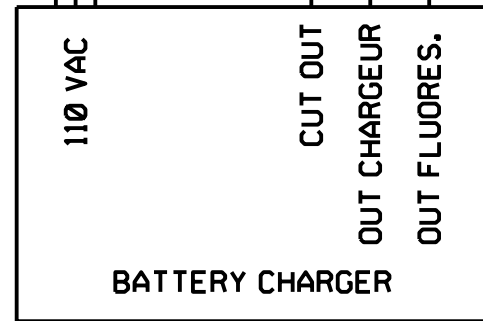

L.H.

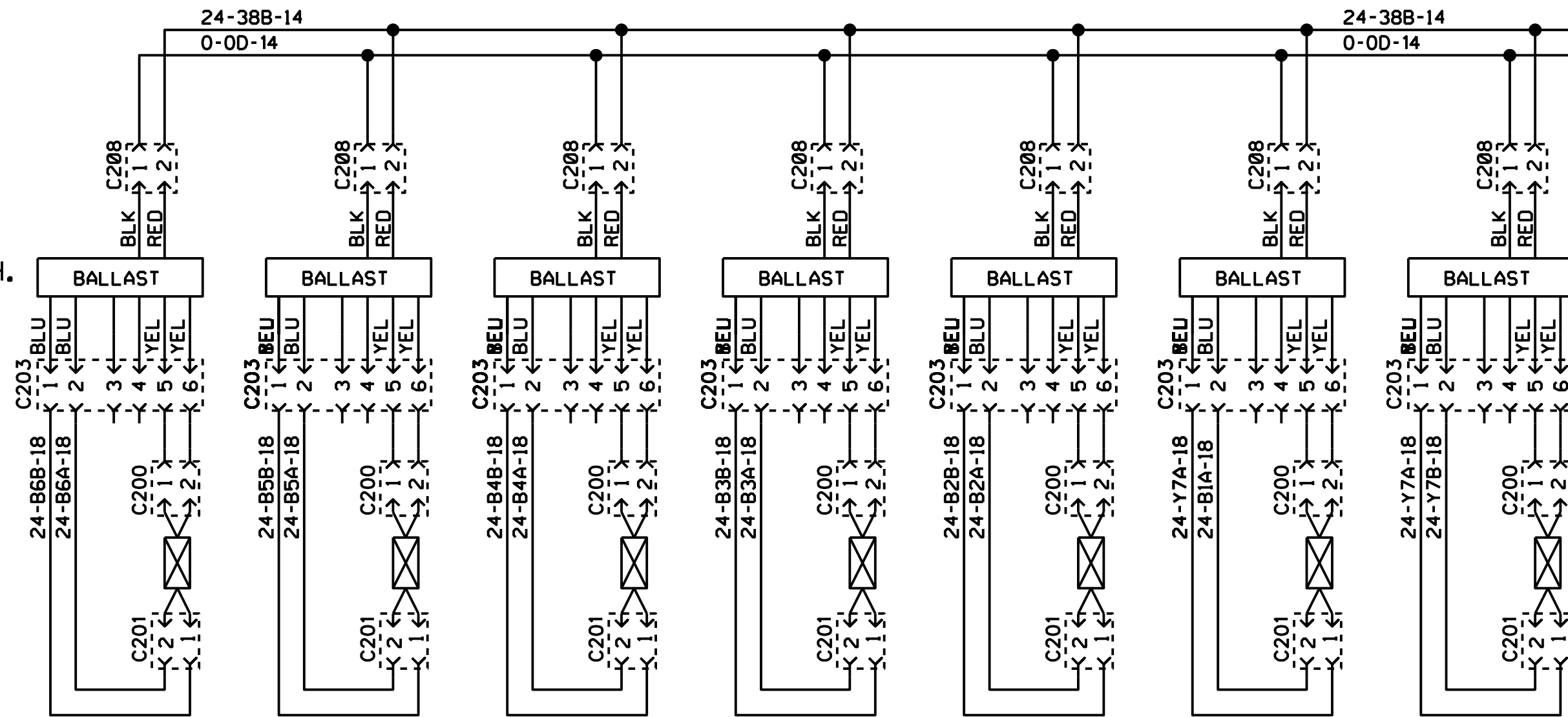

24V FLUORESCENT INTERIOR LIGHTING

H3-45

R.H.

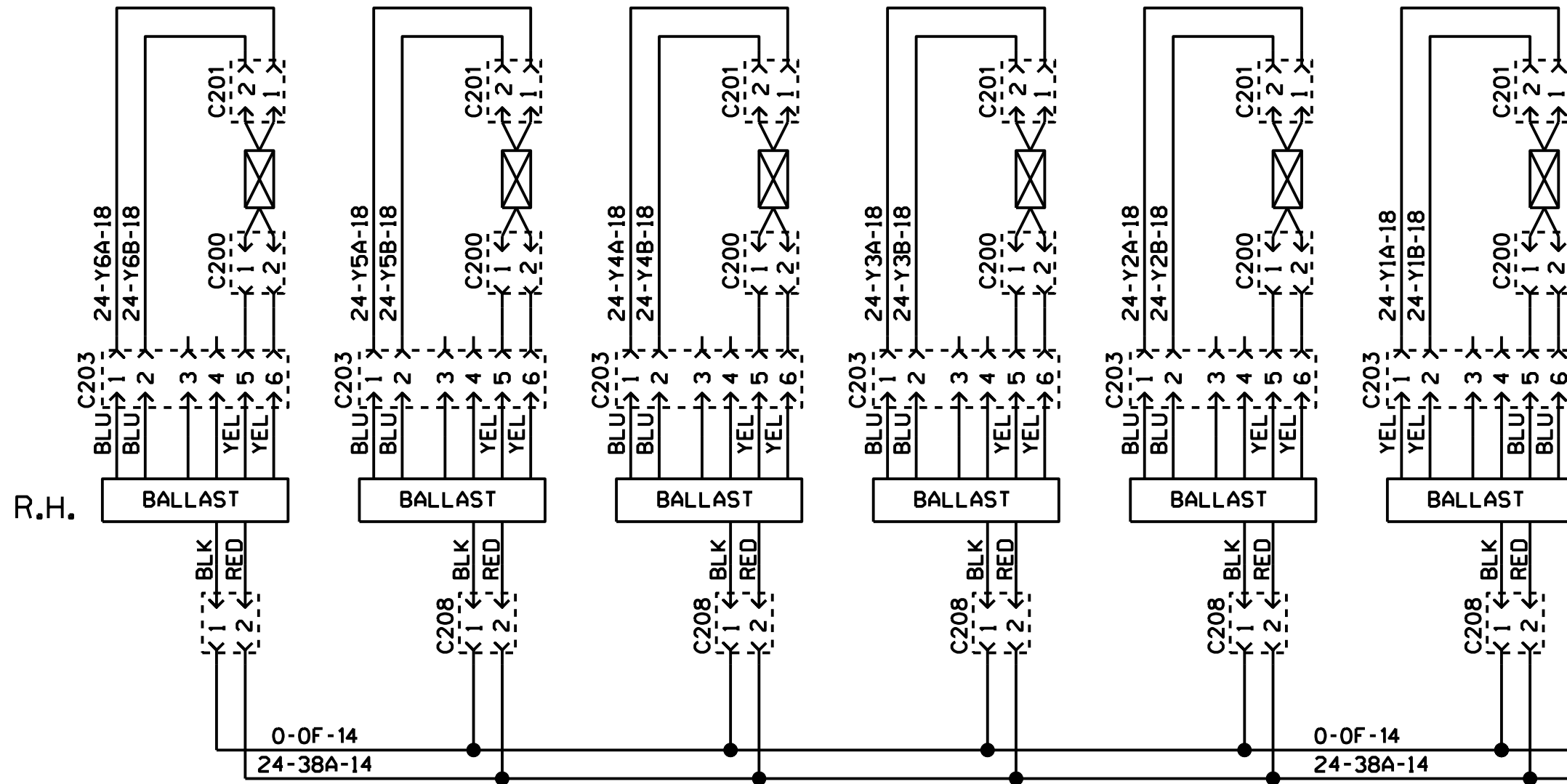

R.H.

FROM GENERAL LTS SWITCH SEE P 11.3  
24V POWER FROM RR.JCT.BOX SEE P. 1.1

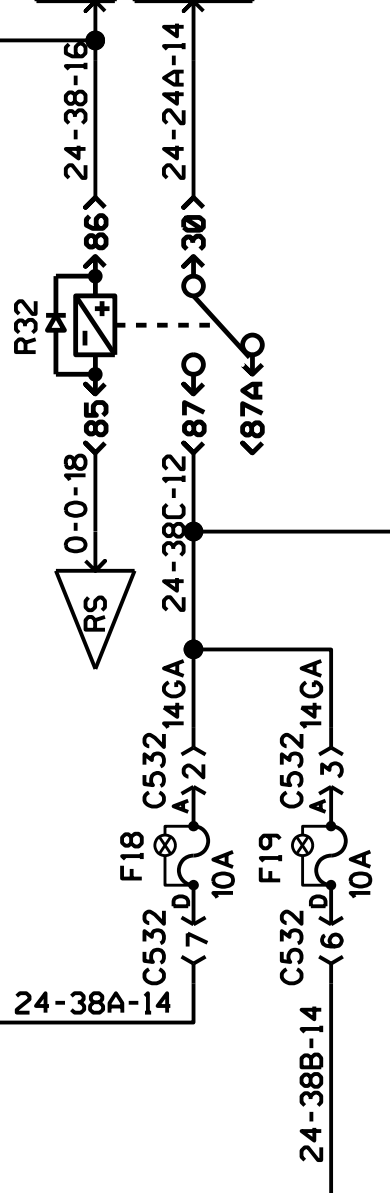

L.H.

BATTERY CHARGER OR IN-STATION LIGHTING

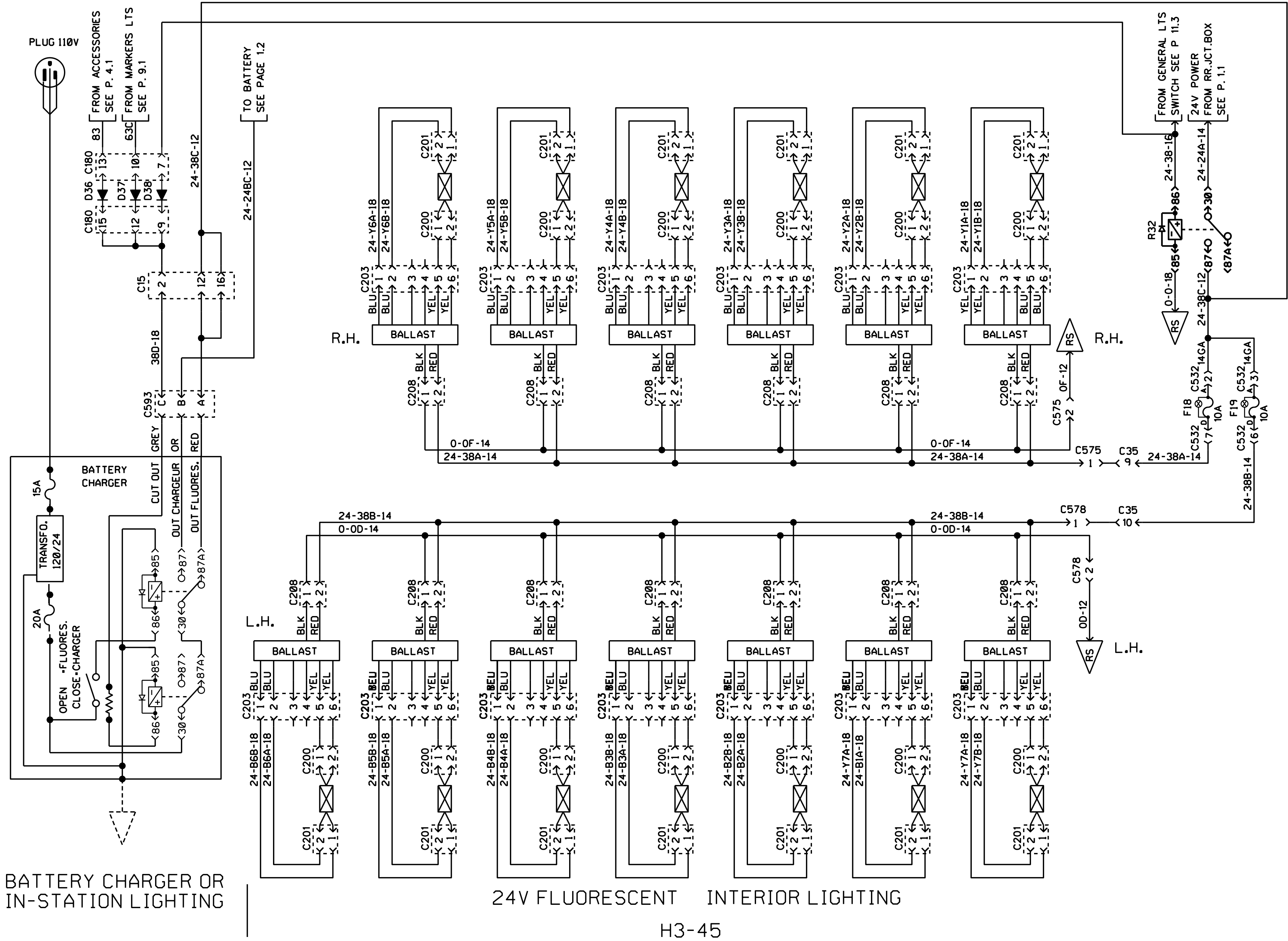

BATTERY CHARGER OR IN-STATION LIGHTING

24V FLUORESCENT INTERIOR LIGHTING  
H3-45



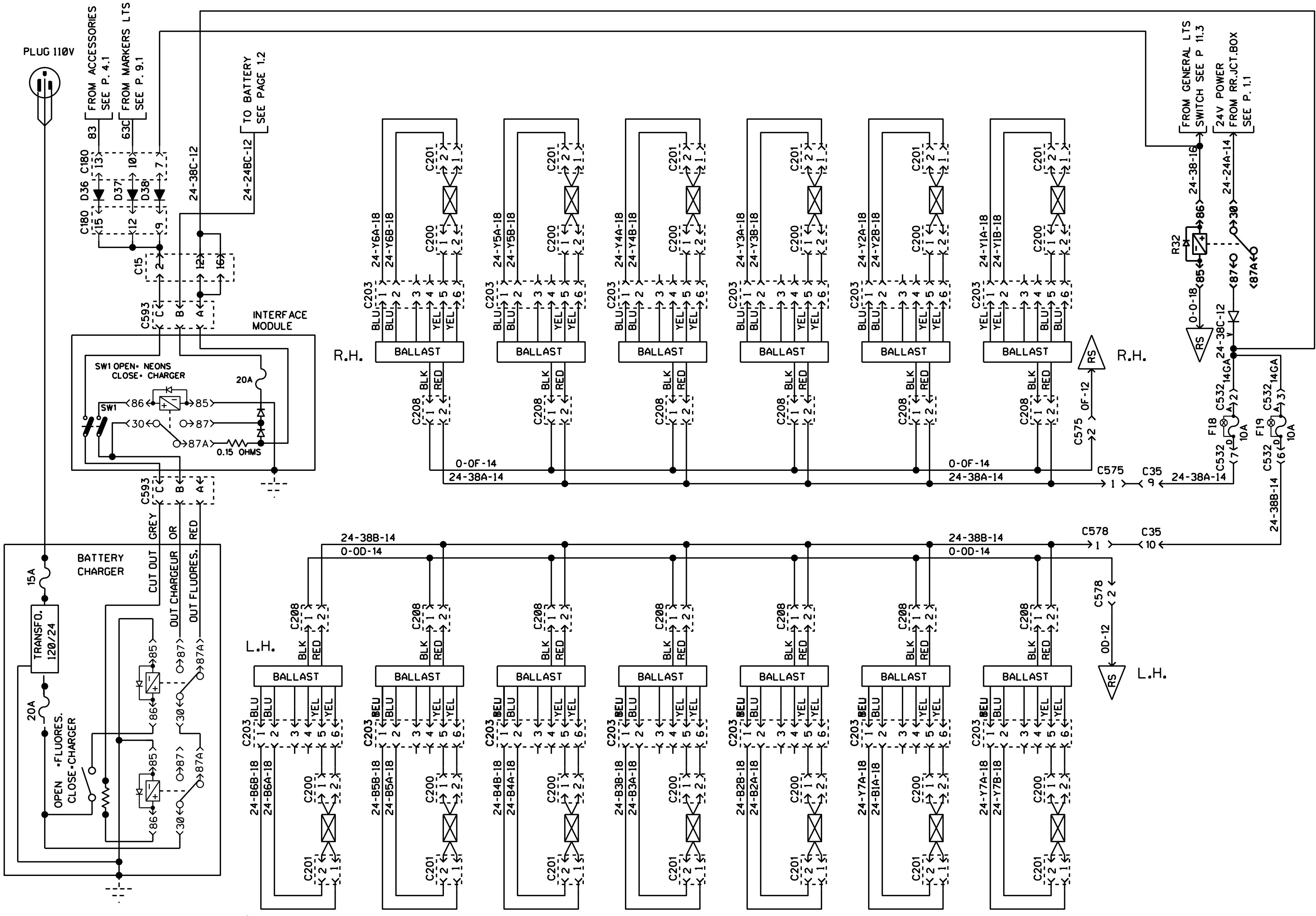

BATTERY CHARGER OR  
IN-STATION LIGHTING

24V FLUORESCENT INTERIOR LIGHTING

H3-45

SHORE PLUG 110V

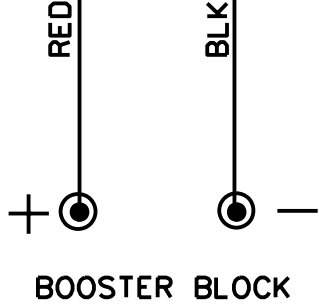
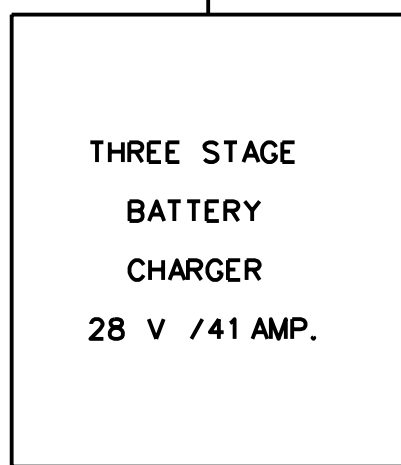
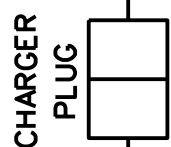
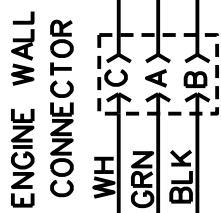
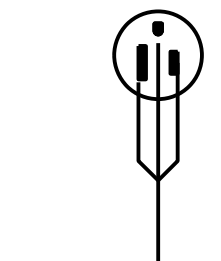

BATTERY CHARGER OR IN-STATION LIGHTING

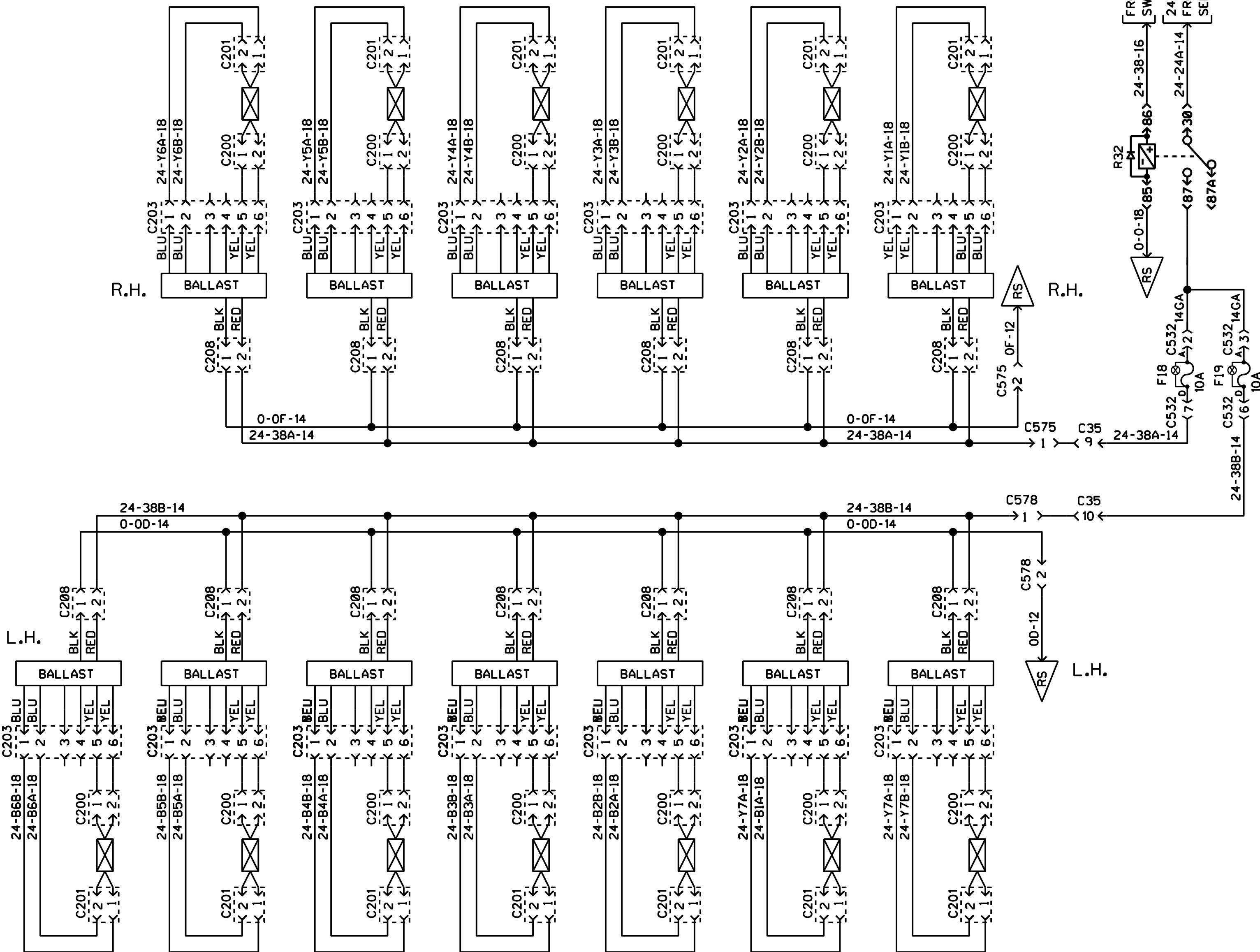

24V FLUORESCENT INTERIOR LIGHTING

H3-45

PLUG 110V

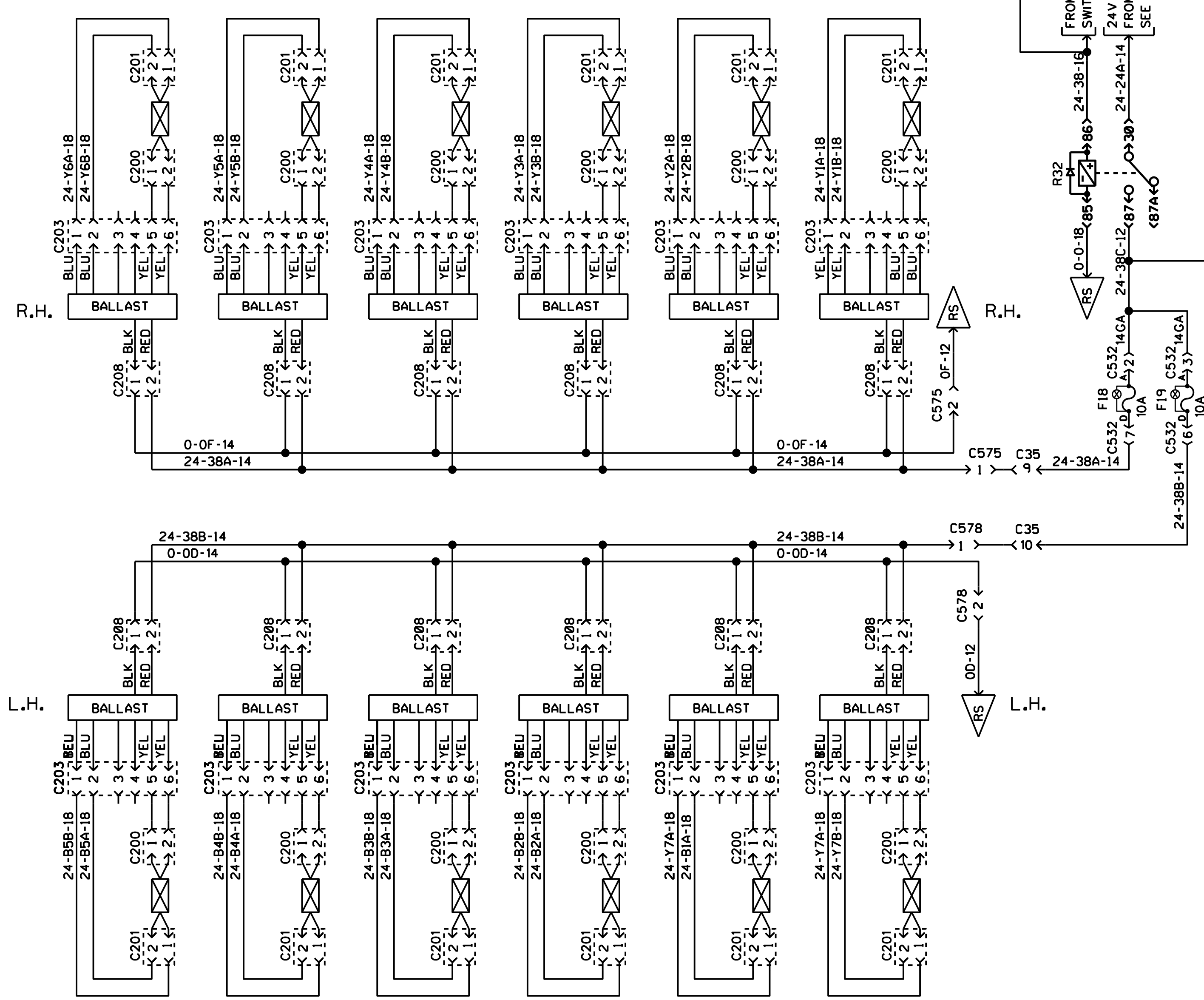
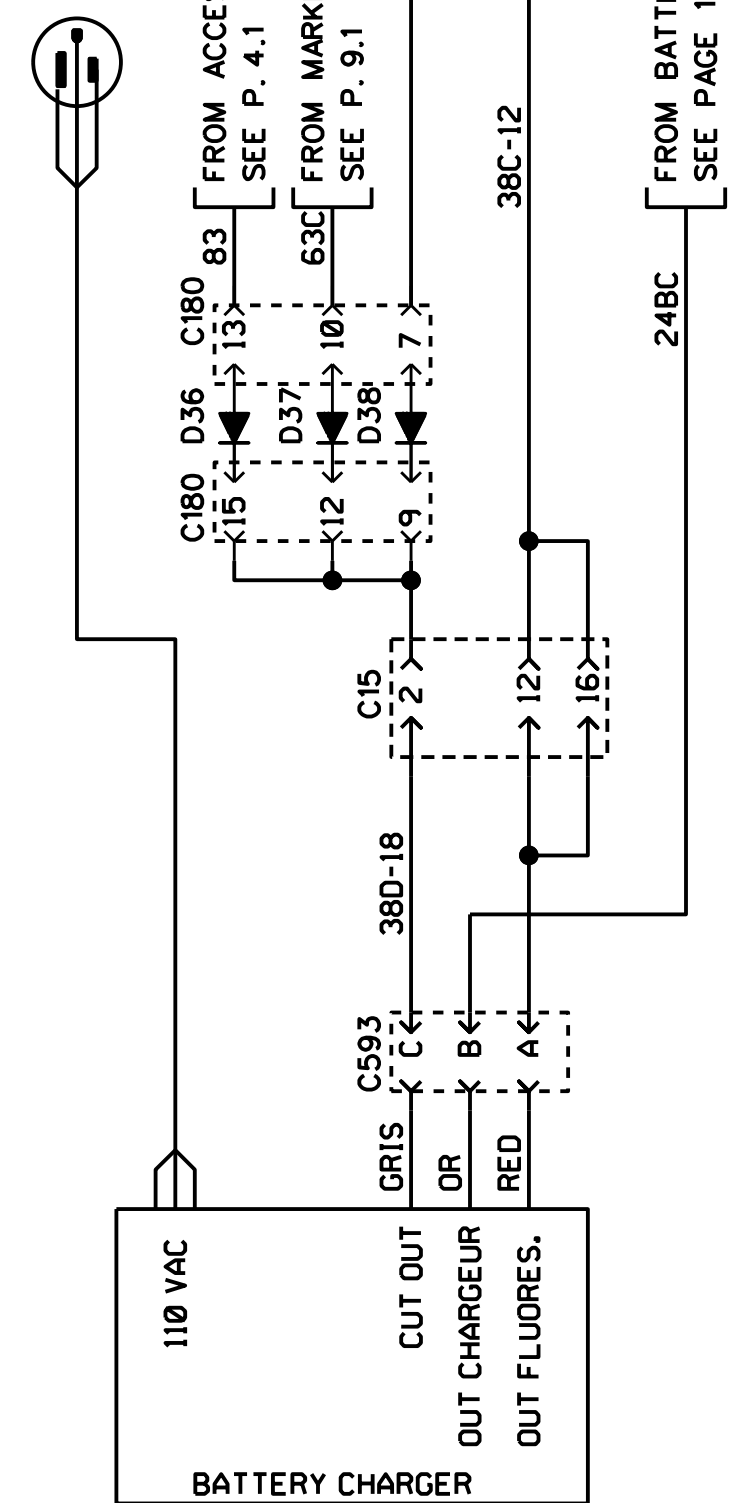

BATTERY CHARGER OR IN-STATION LIGHTING

24V FLUORESCENT INTERIOR LIGHTING

H3-41

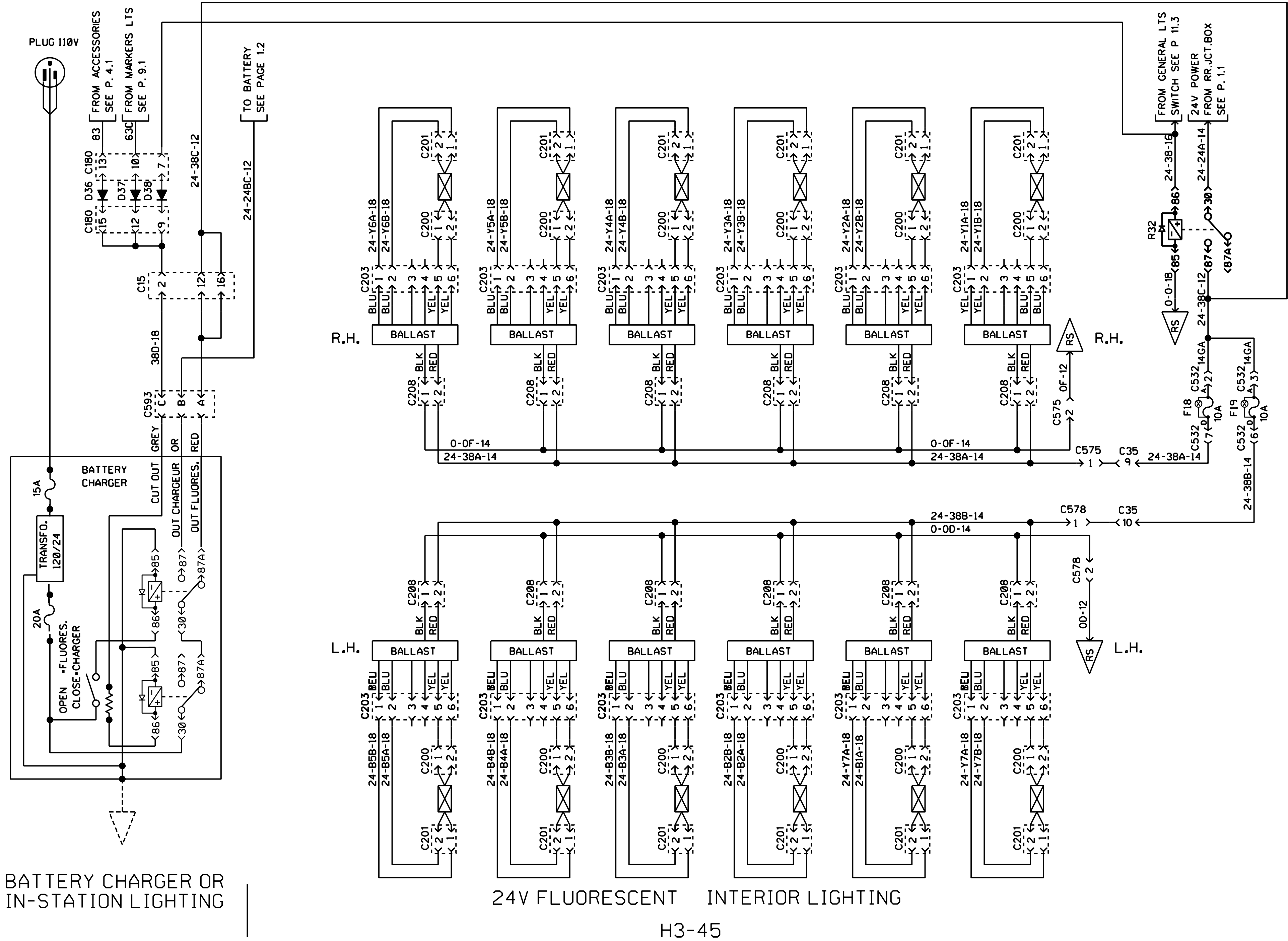

BATTERY CHARGER OR IN-STATION LIGHTING

24V FLUORESCENT INTERIOR LIGHTING  
H3-45

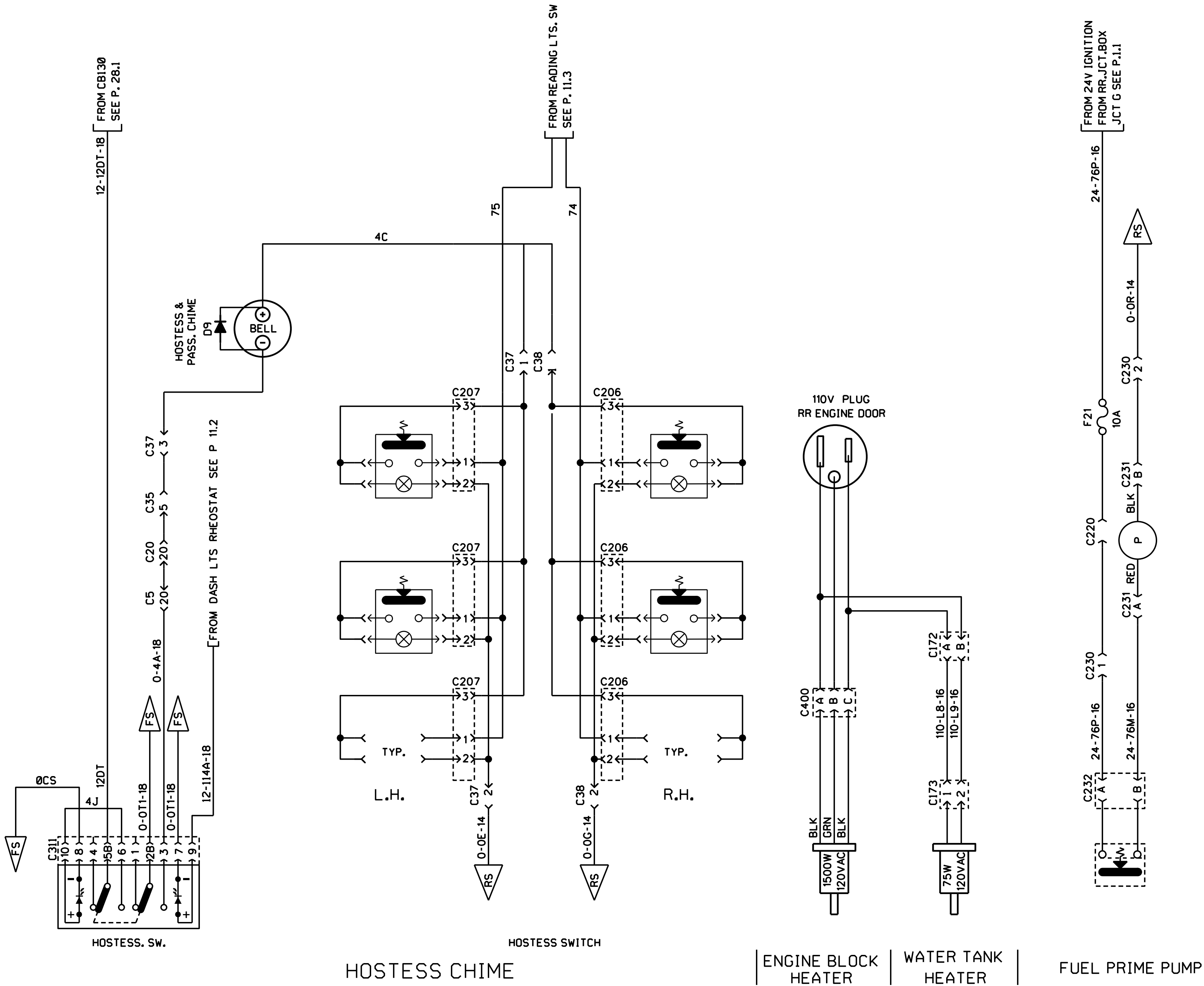

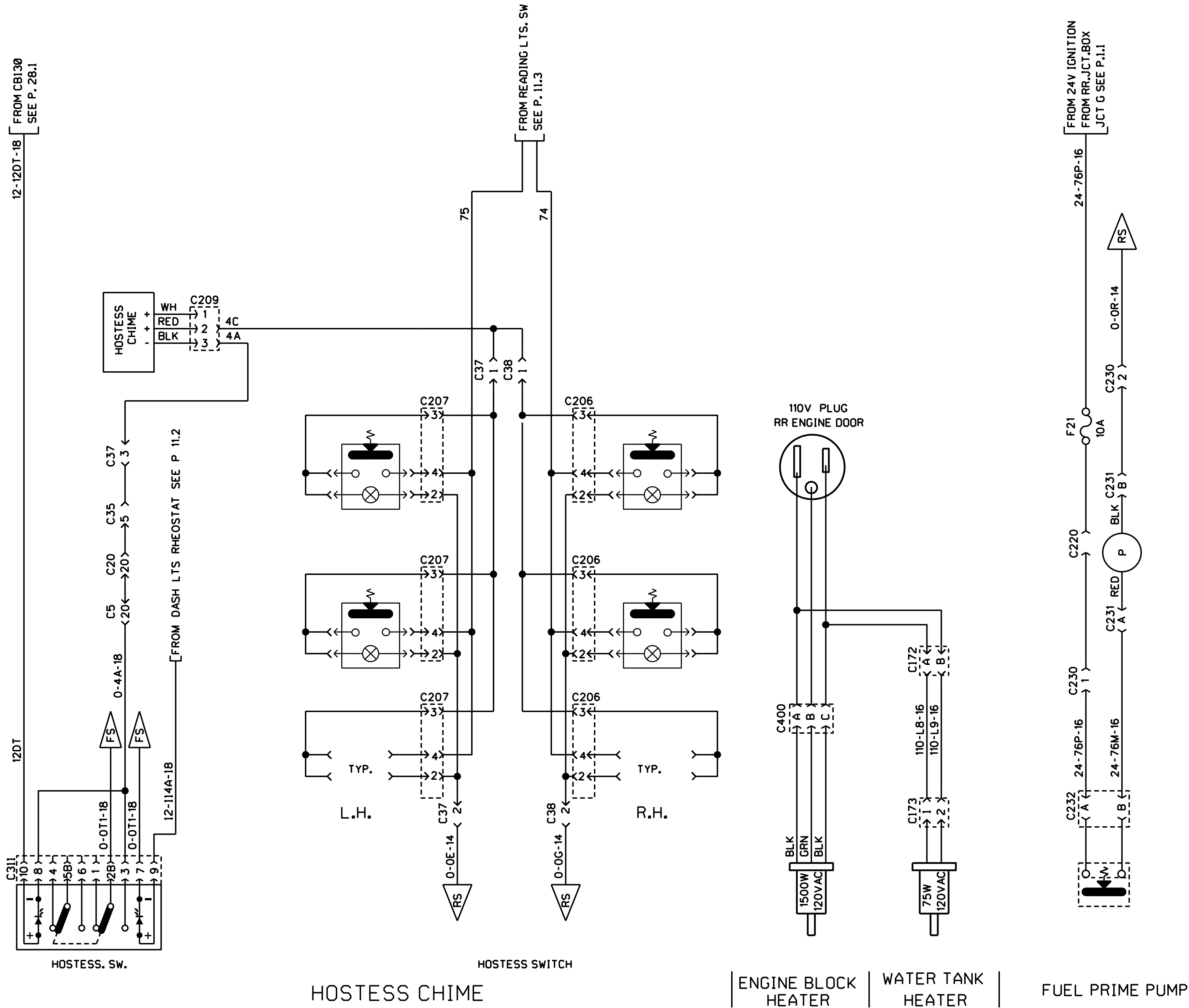

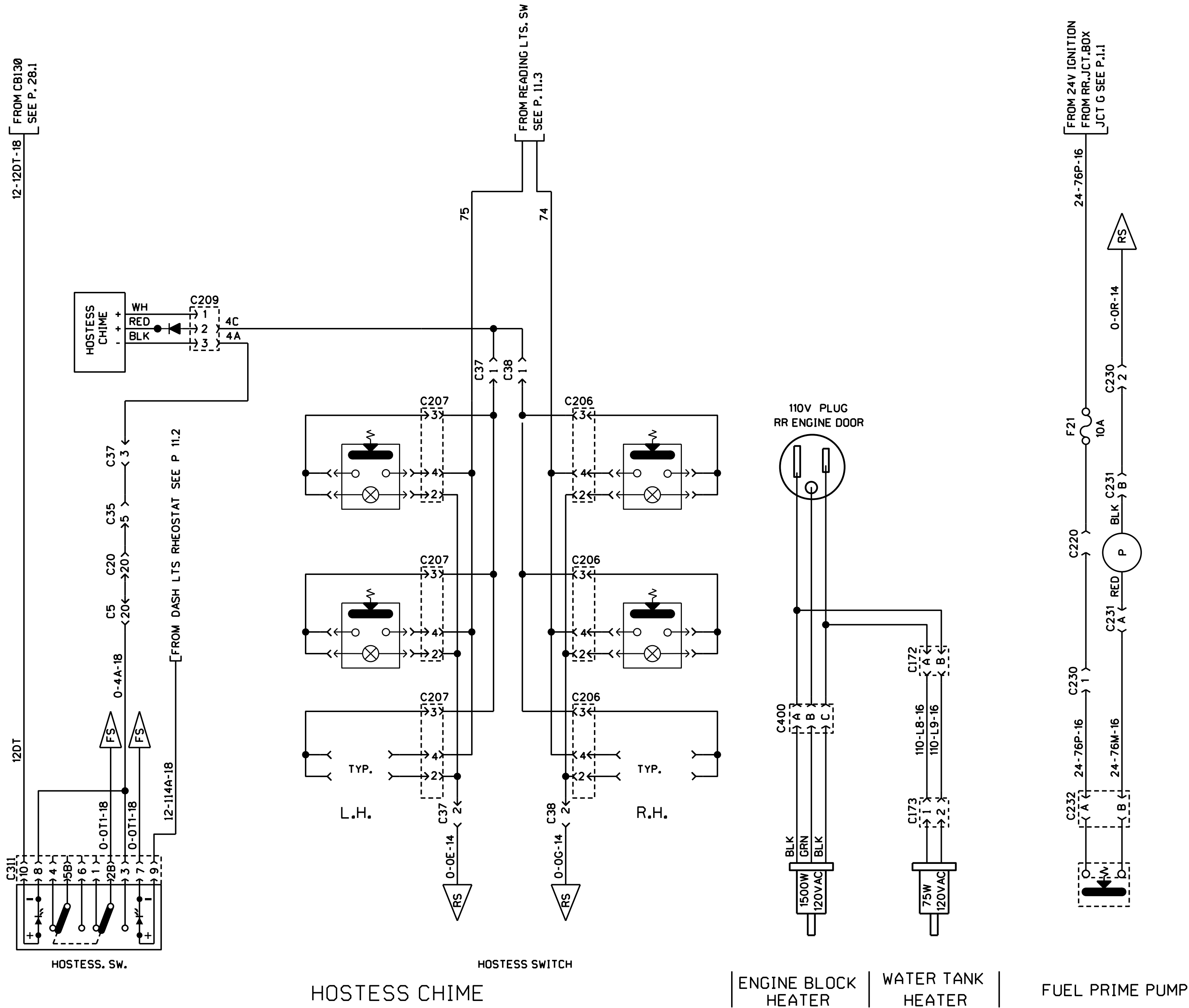



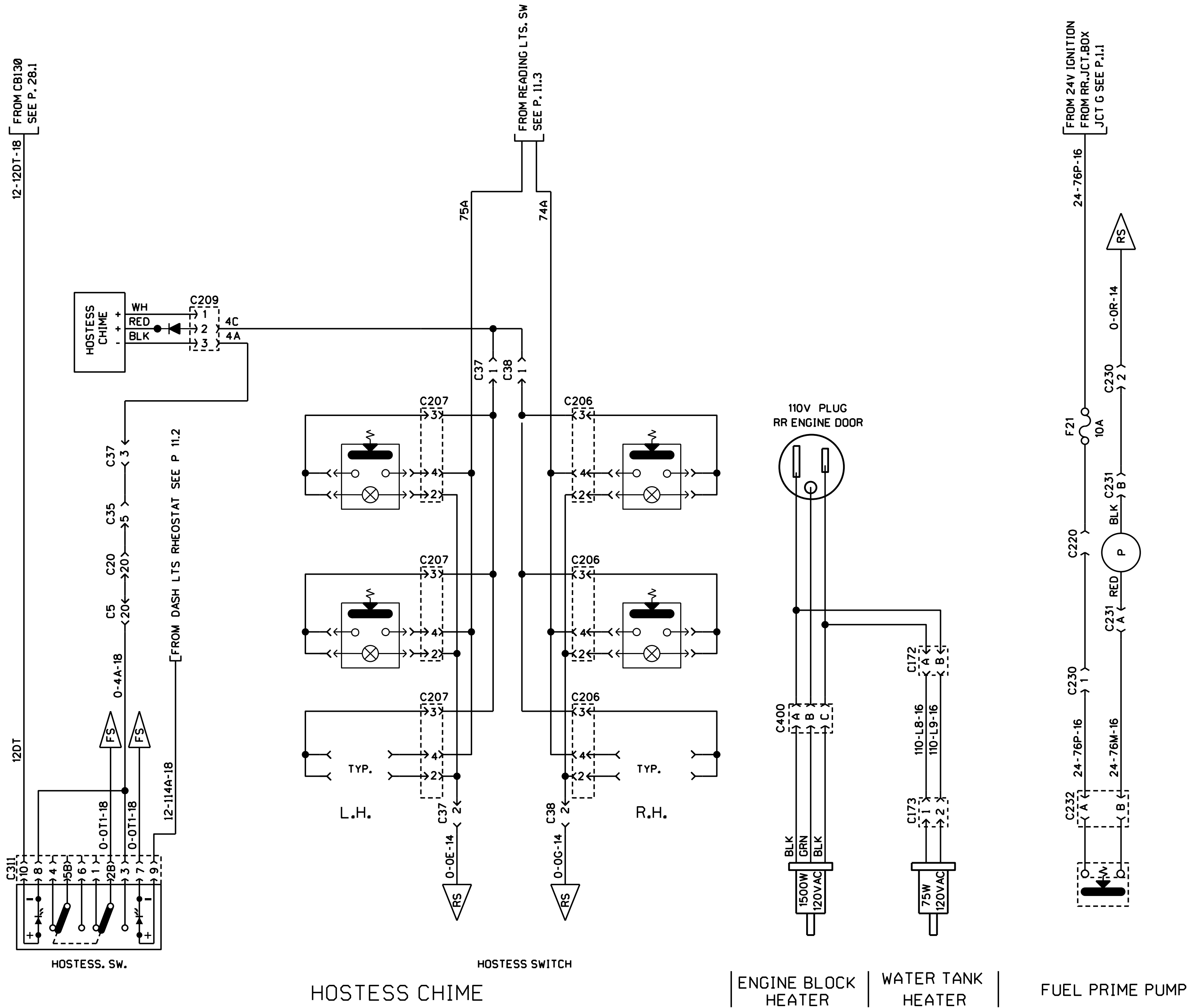

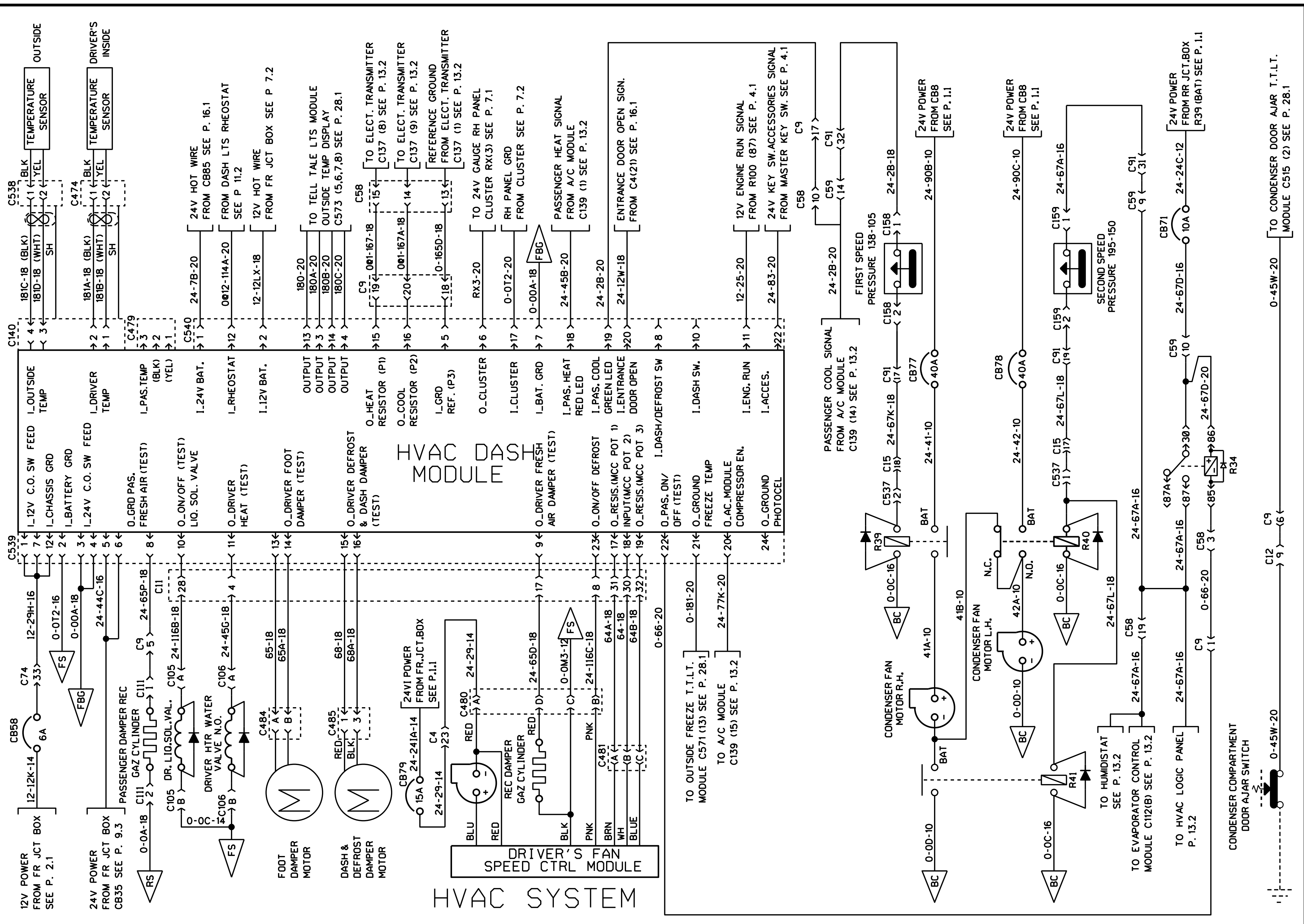

HVAC SYSTEM

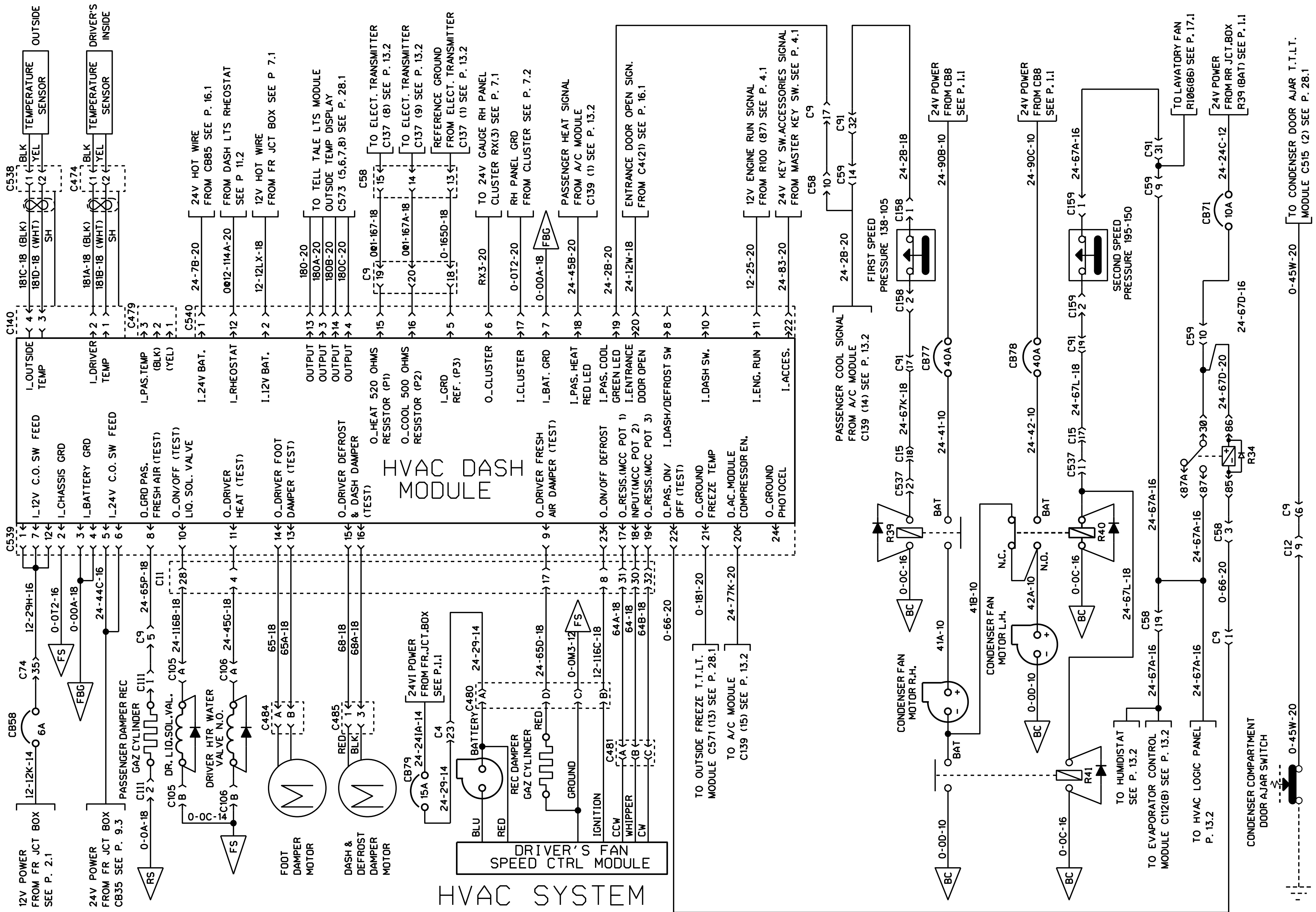

HVAC SYSTEM

I.V.A.C. D.A.S.H. M.O.D.U.L.E.

DRIVER'S FAN SPEED CTRL MODULE

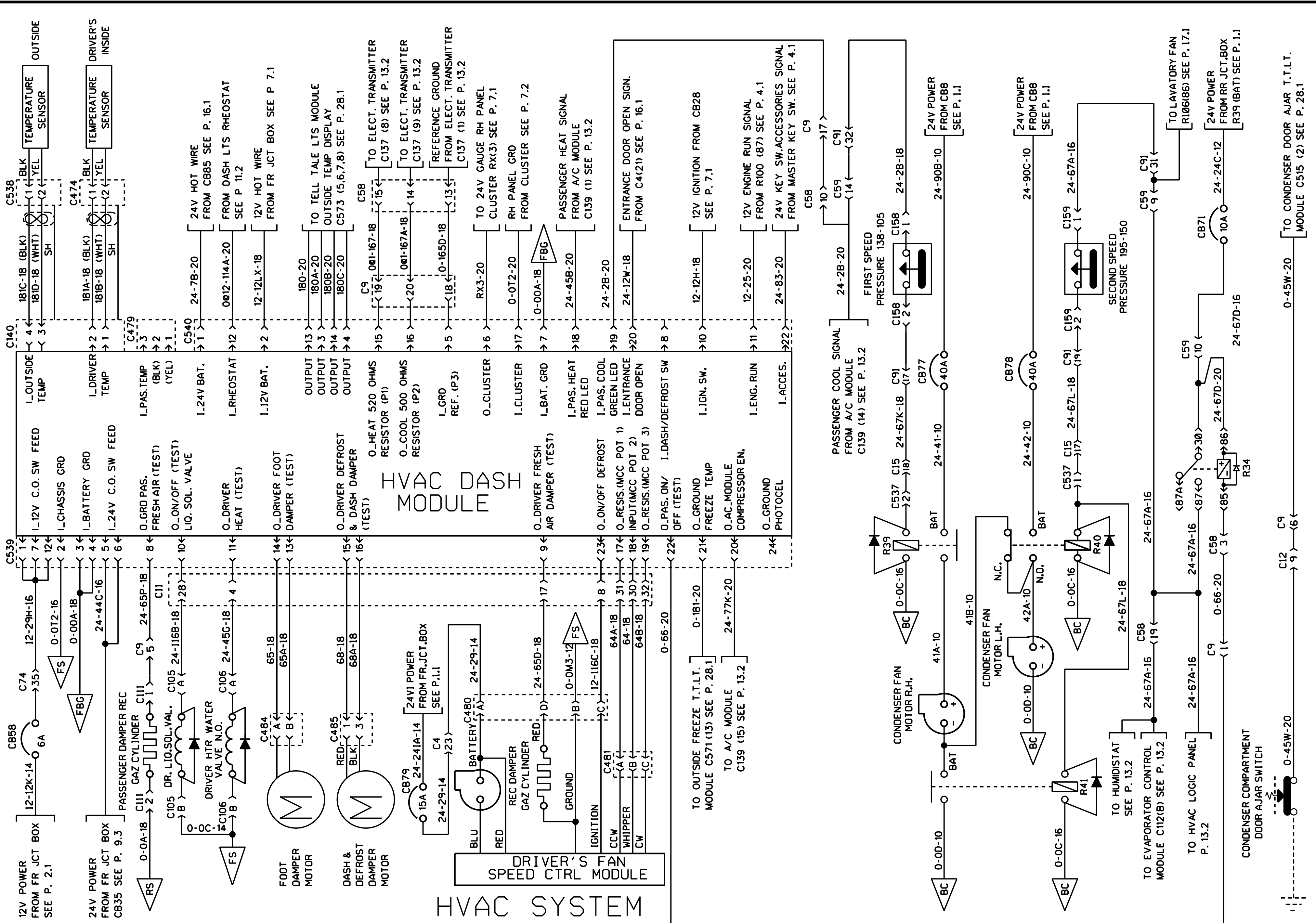



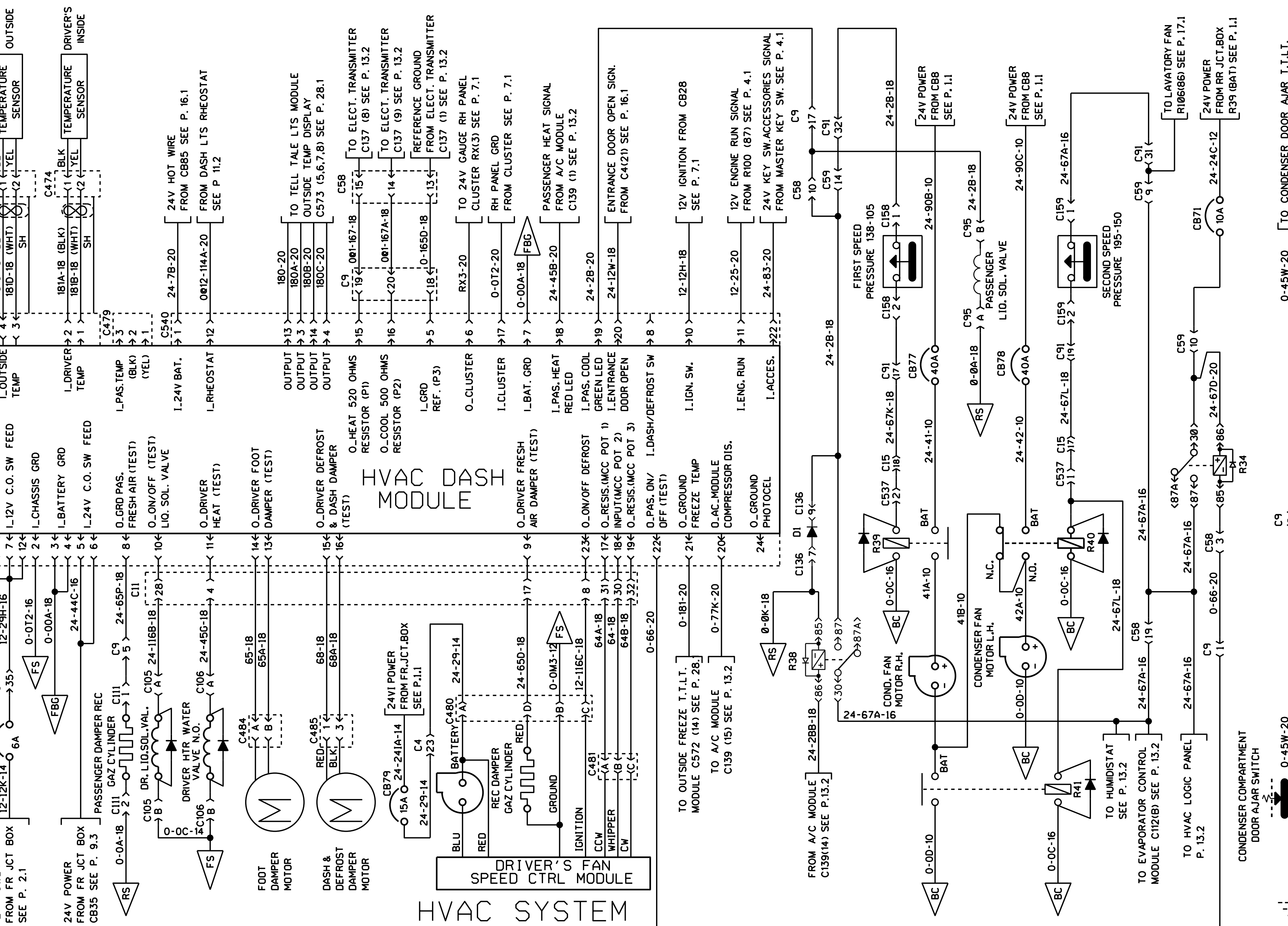

HVAC DASH MODULE

HVAC SYSTEM



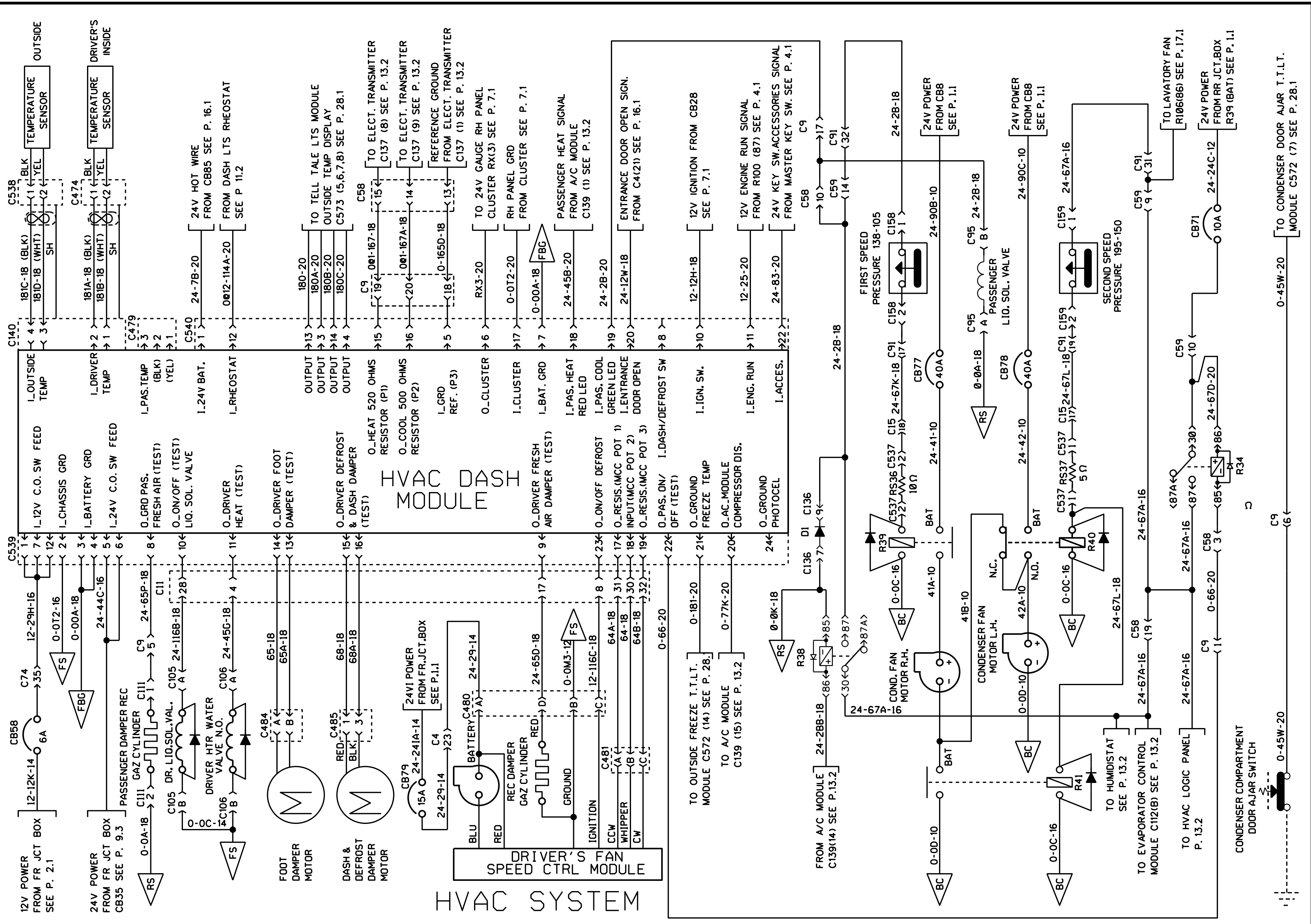

HVAC SYSTEM



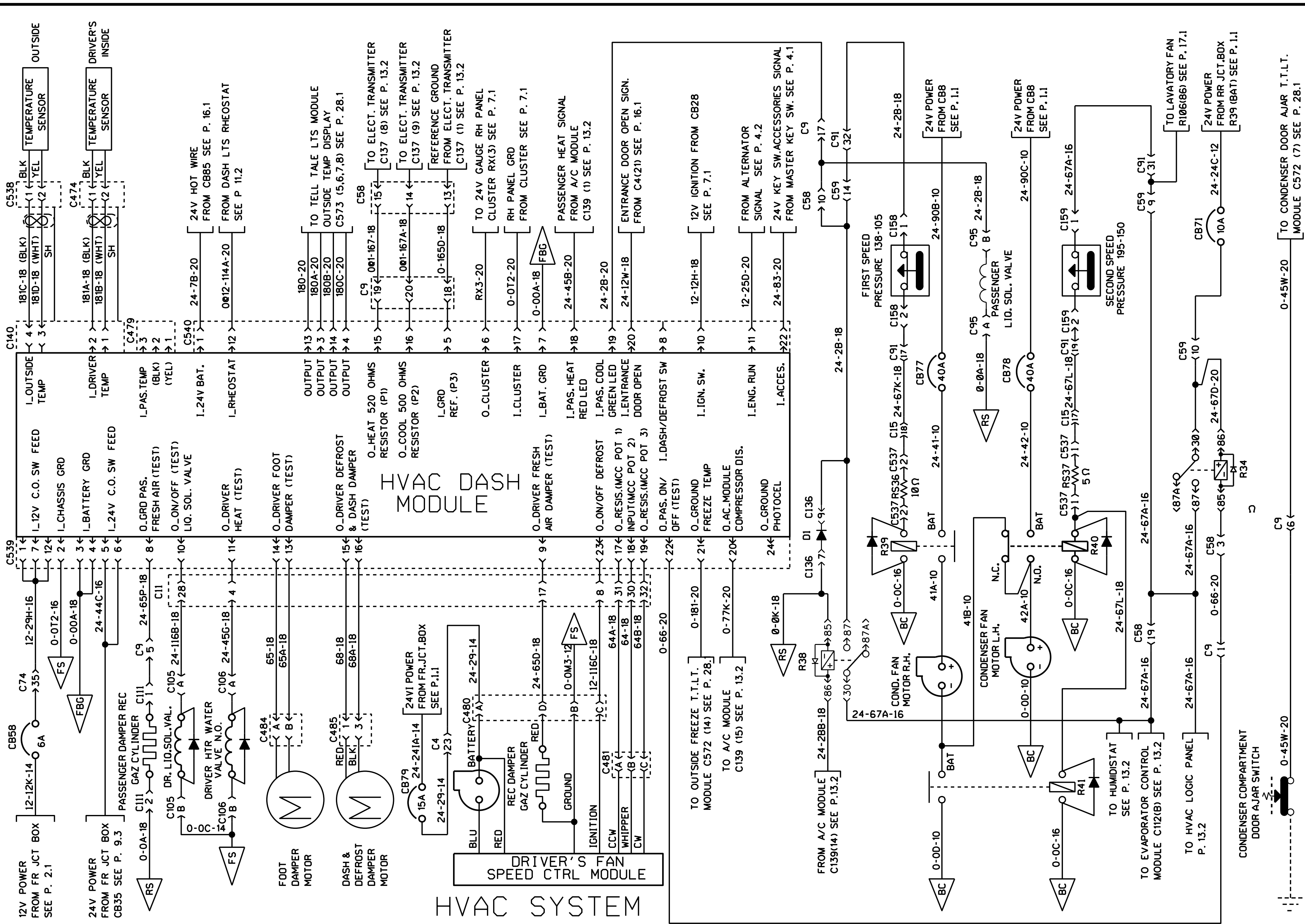



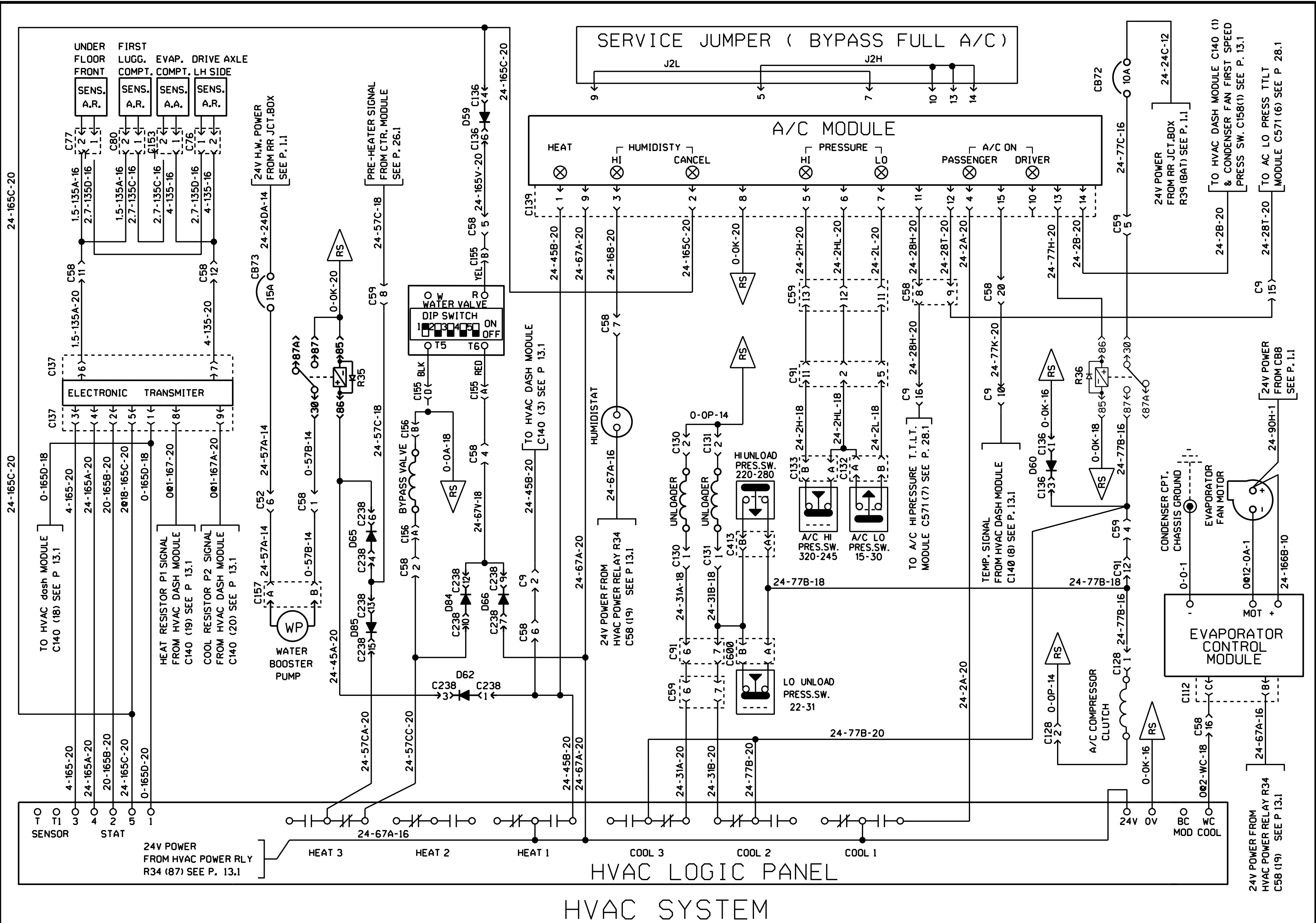

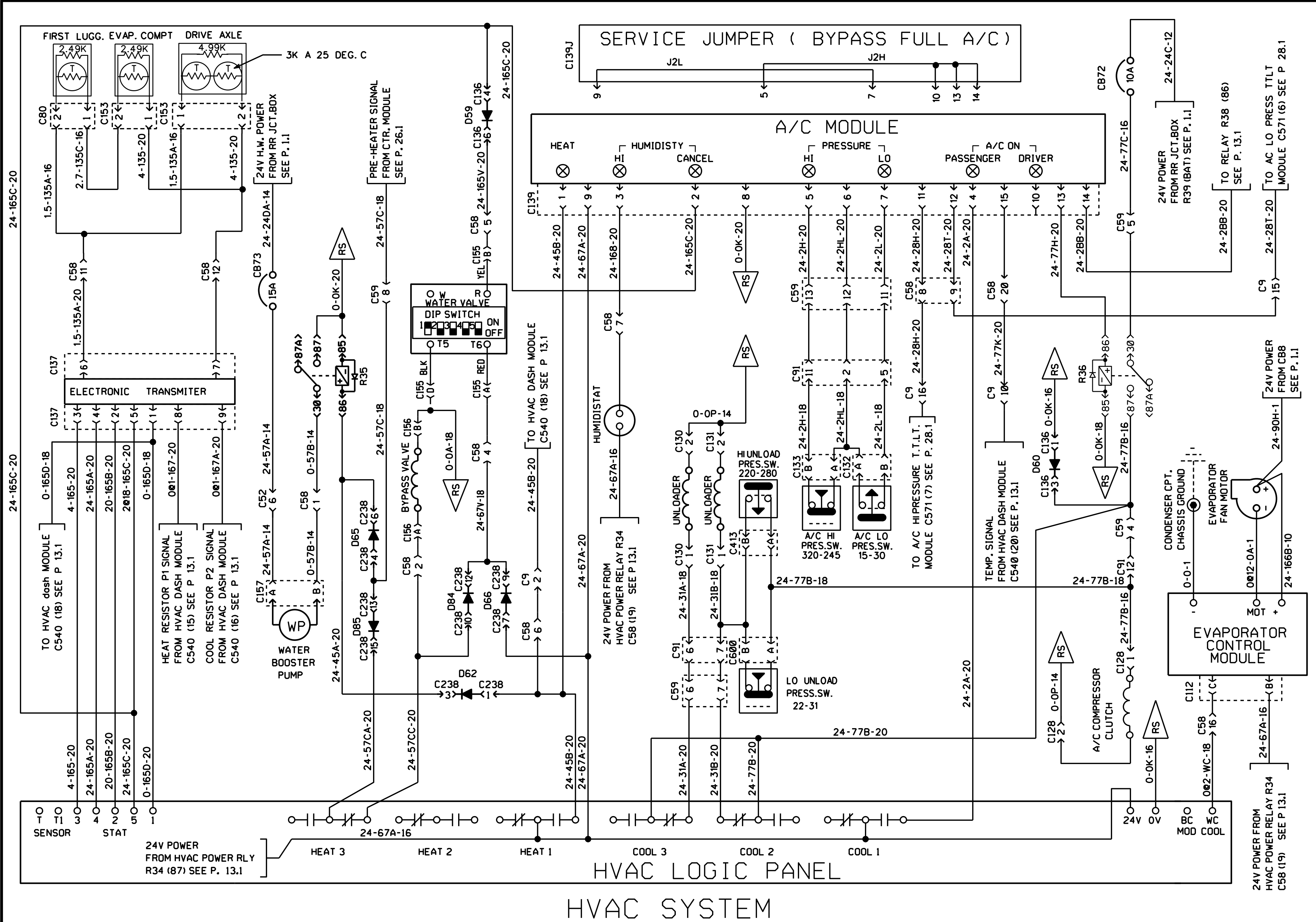

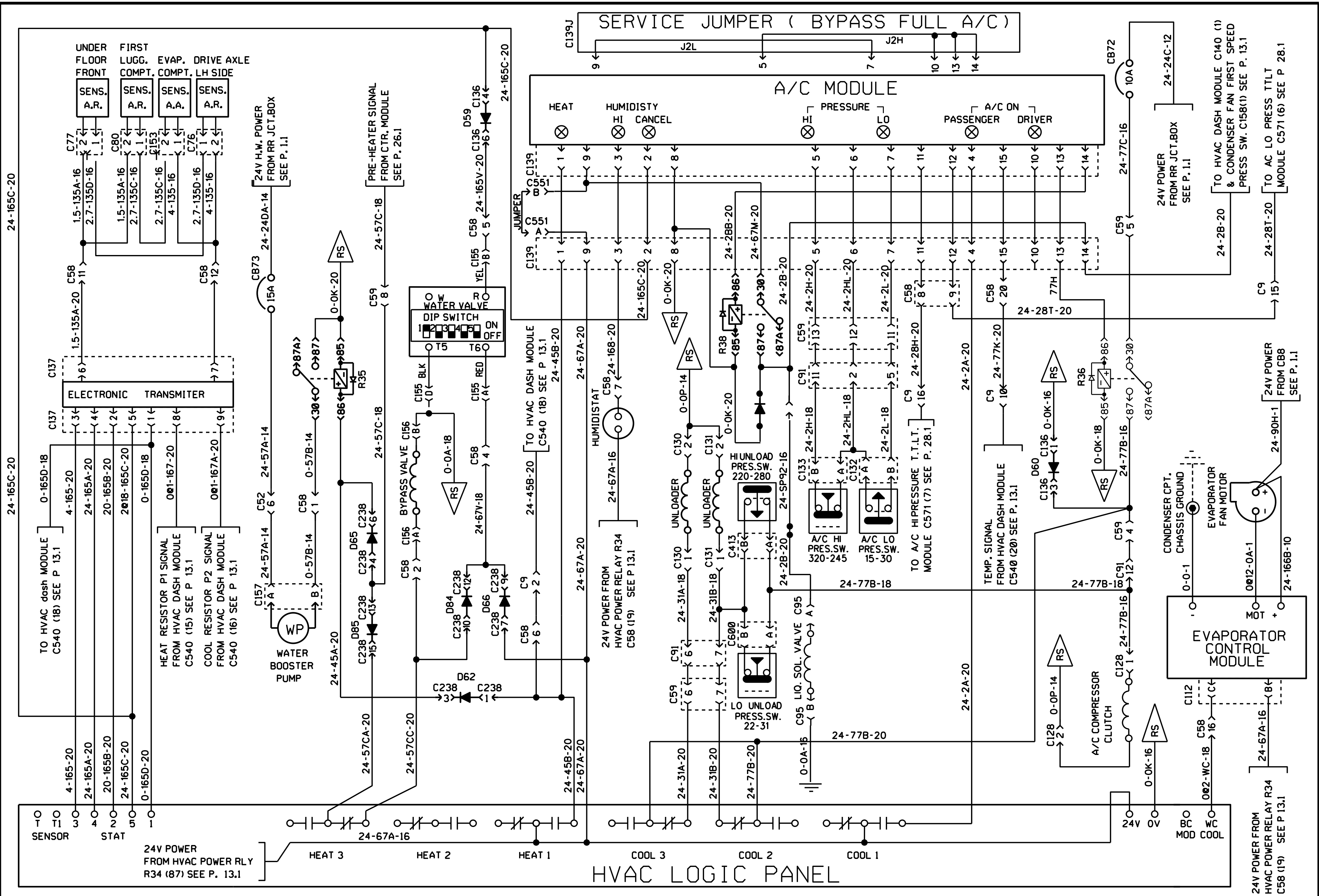

HVAC SYSTEM

EFF. W2285 TO W2457

24-165C-20

24-165C-20

24-165C-20

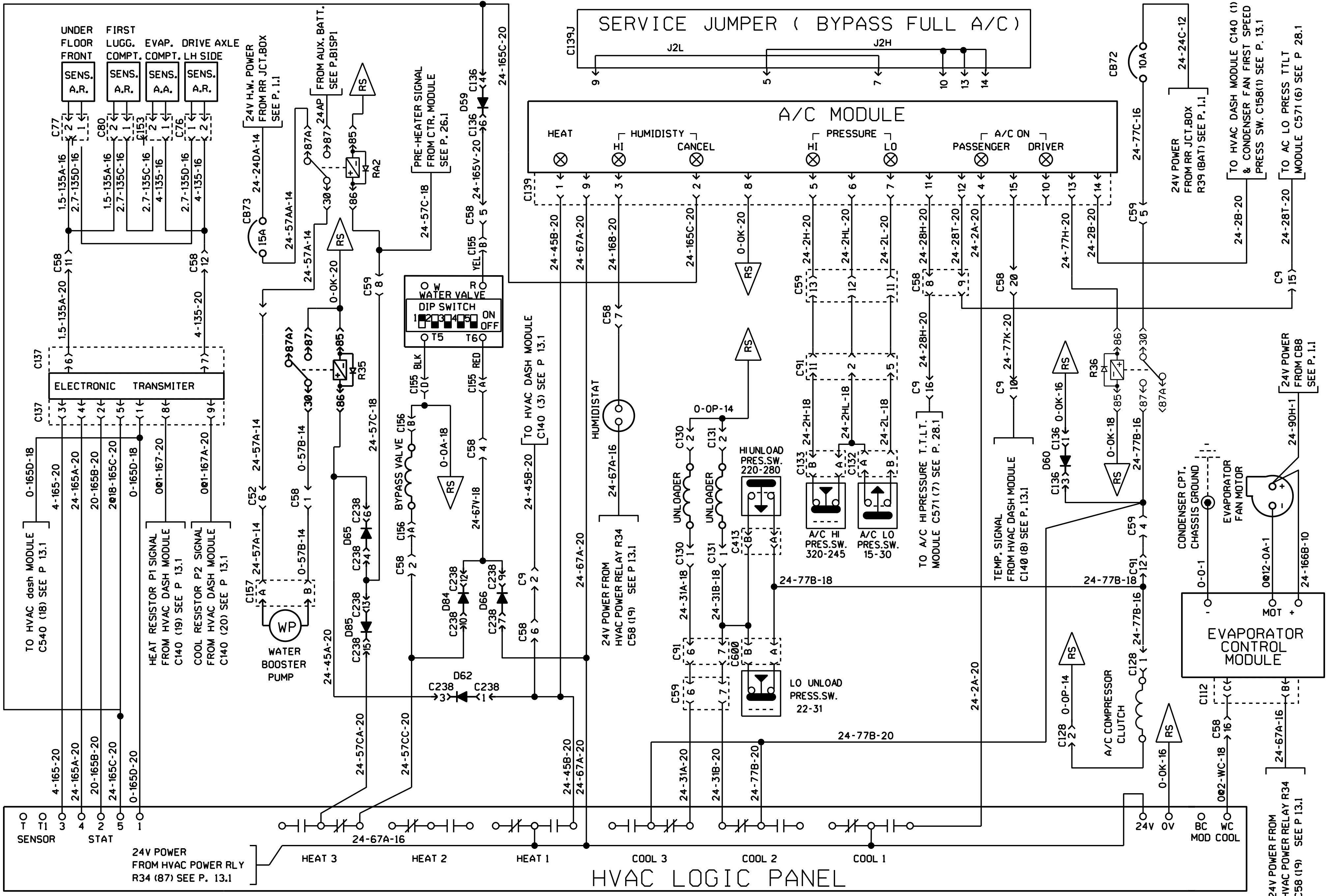

# HVAC SYSTEM

ORLEANS & ADIRONDACK







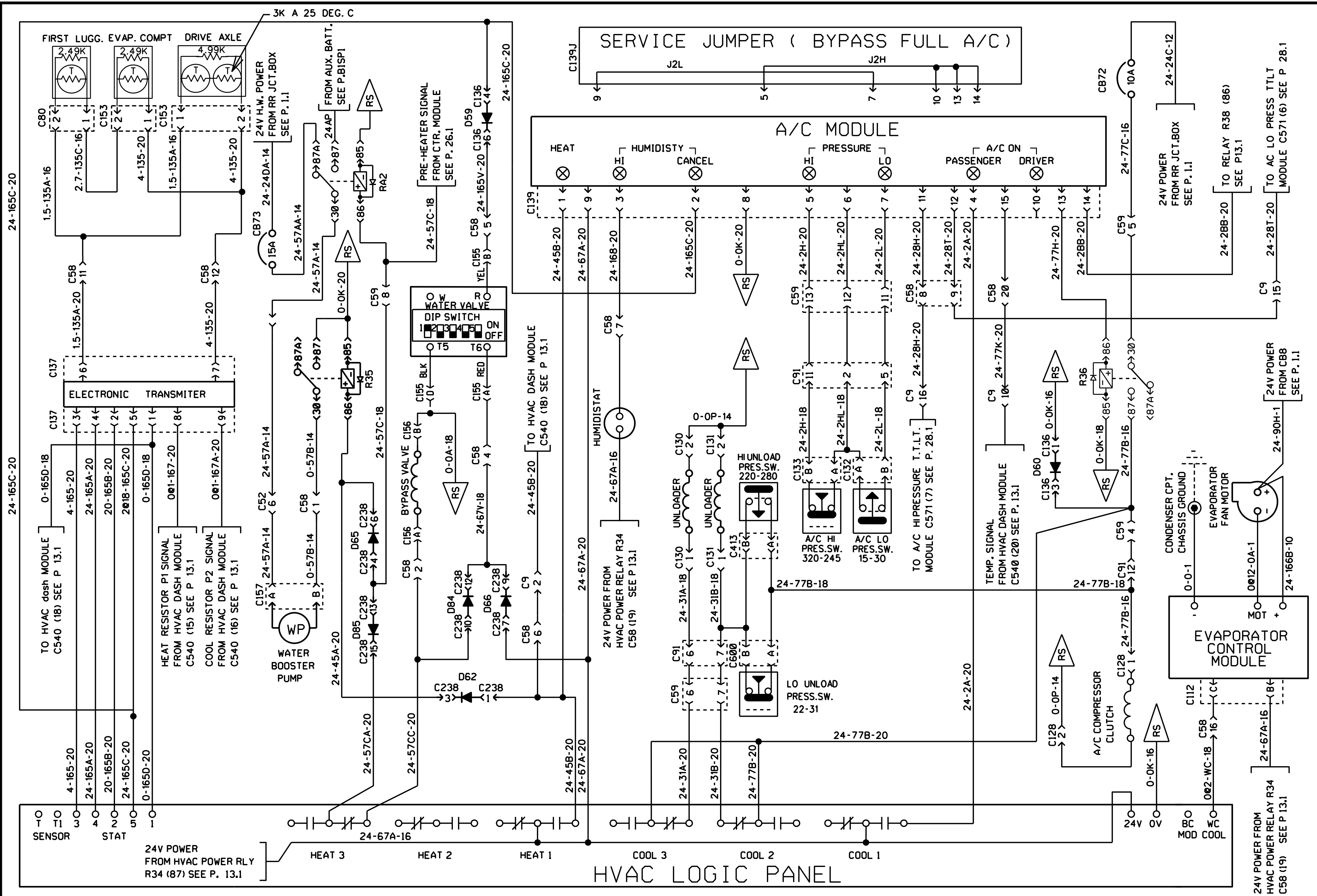

# HVAC SYSTEM

ORLEANS & ADIRONDACK

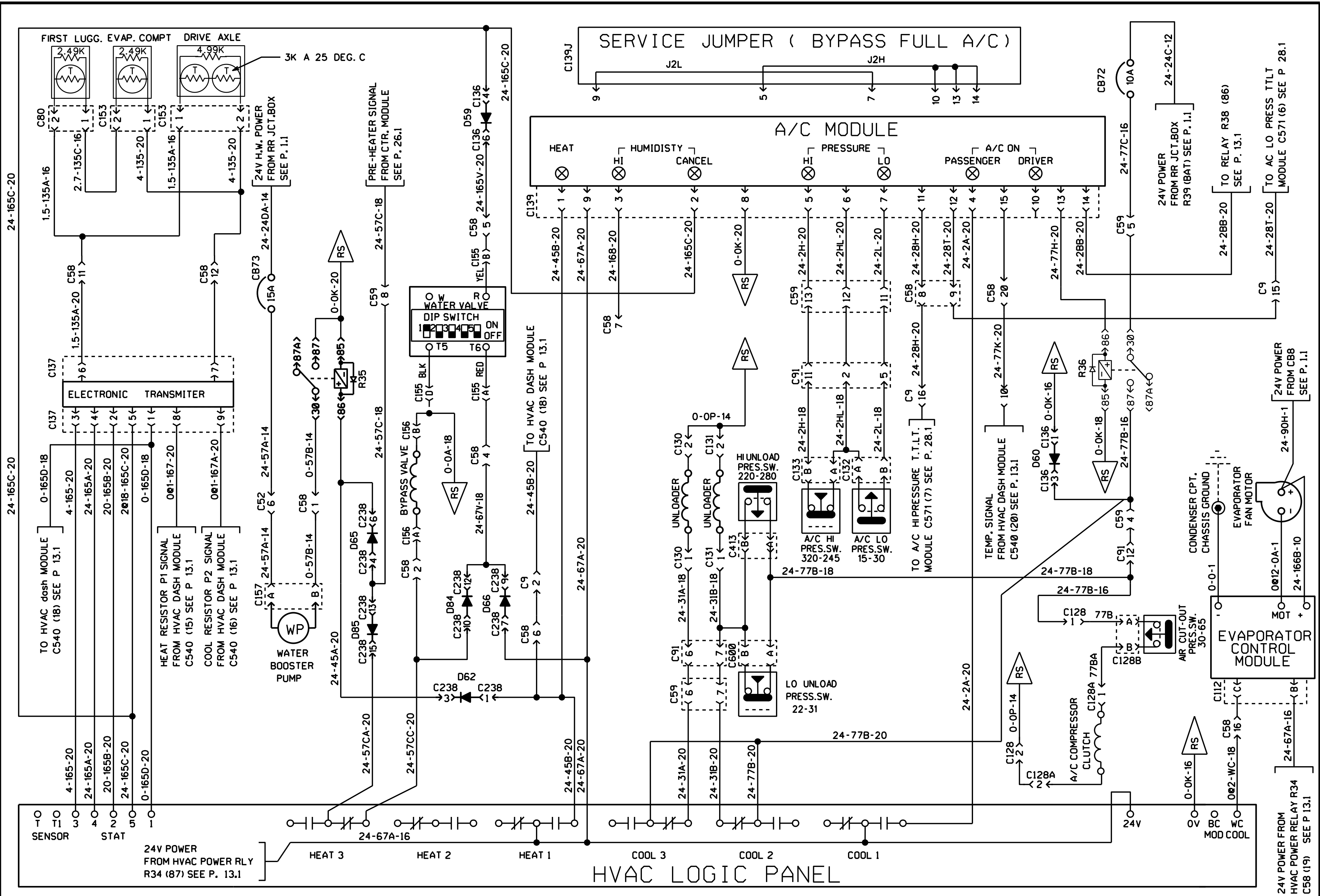

HVAC SYSTEM

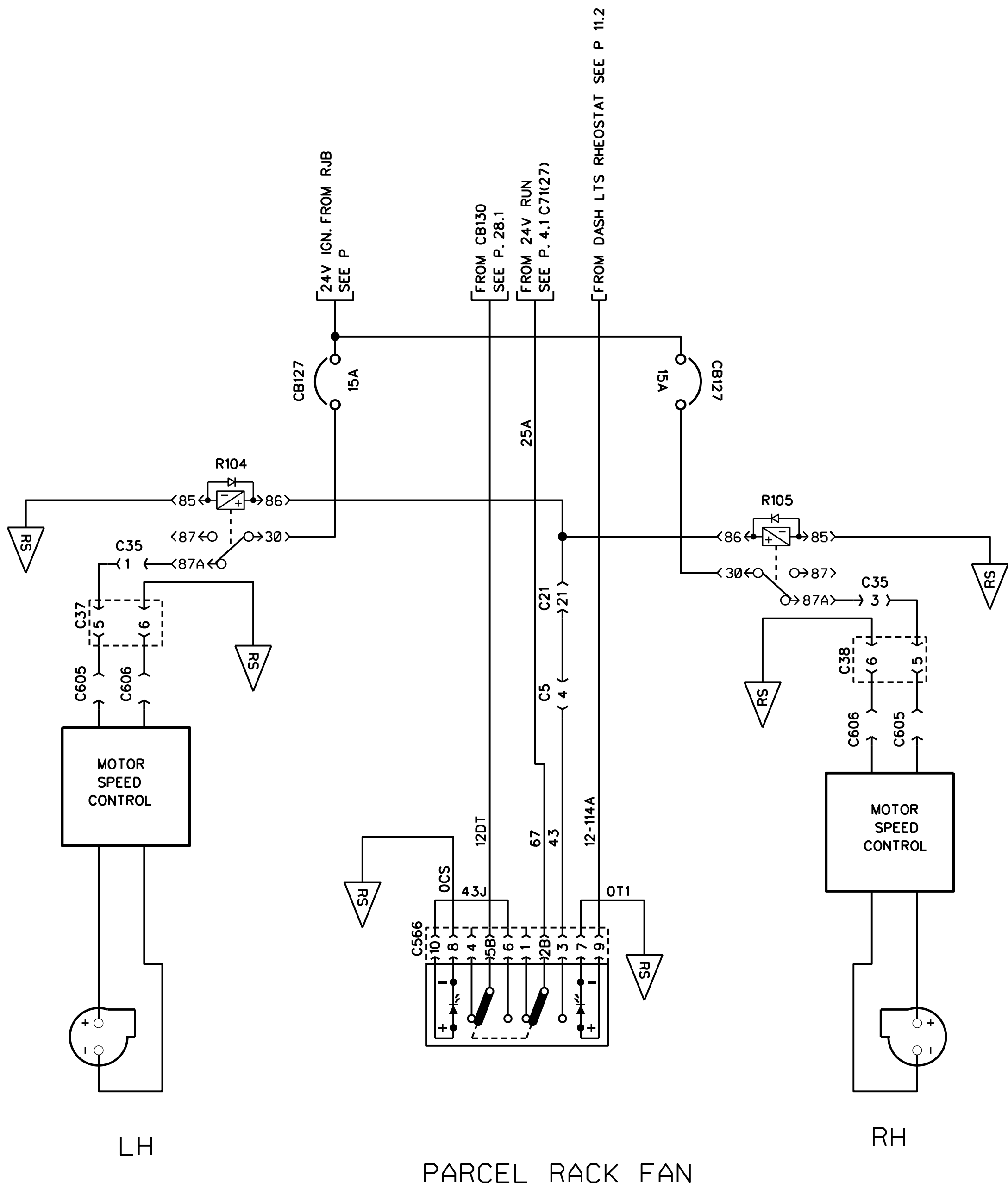

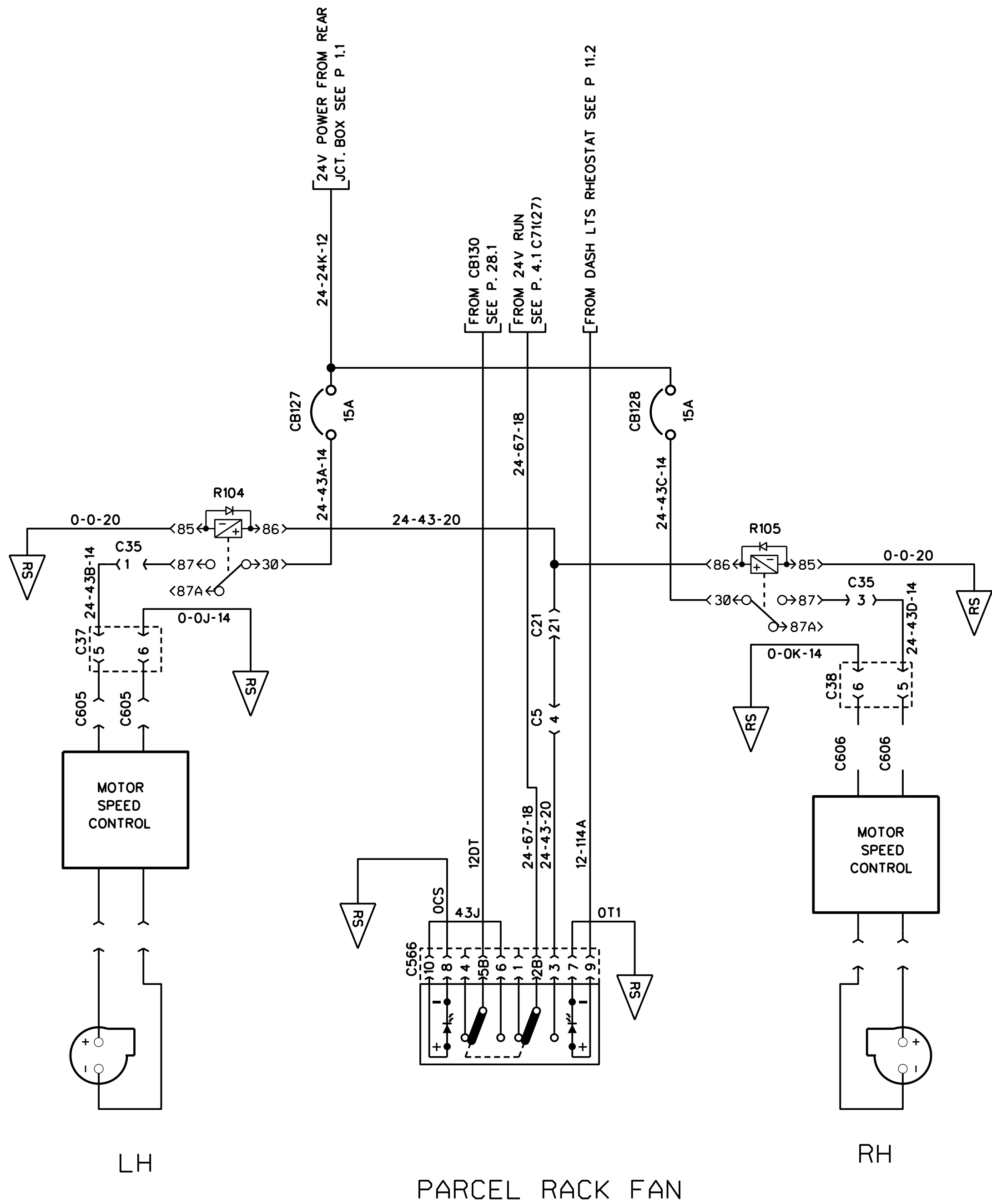

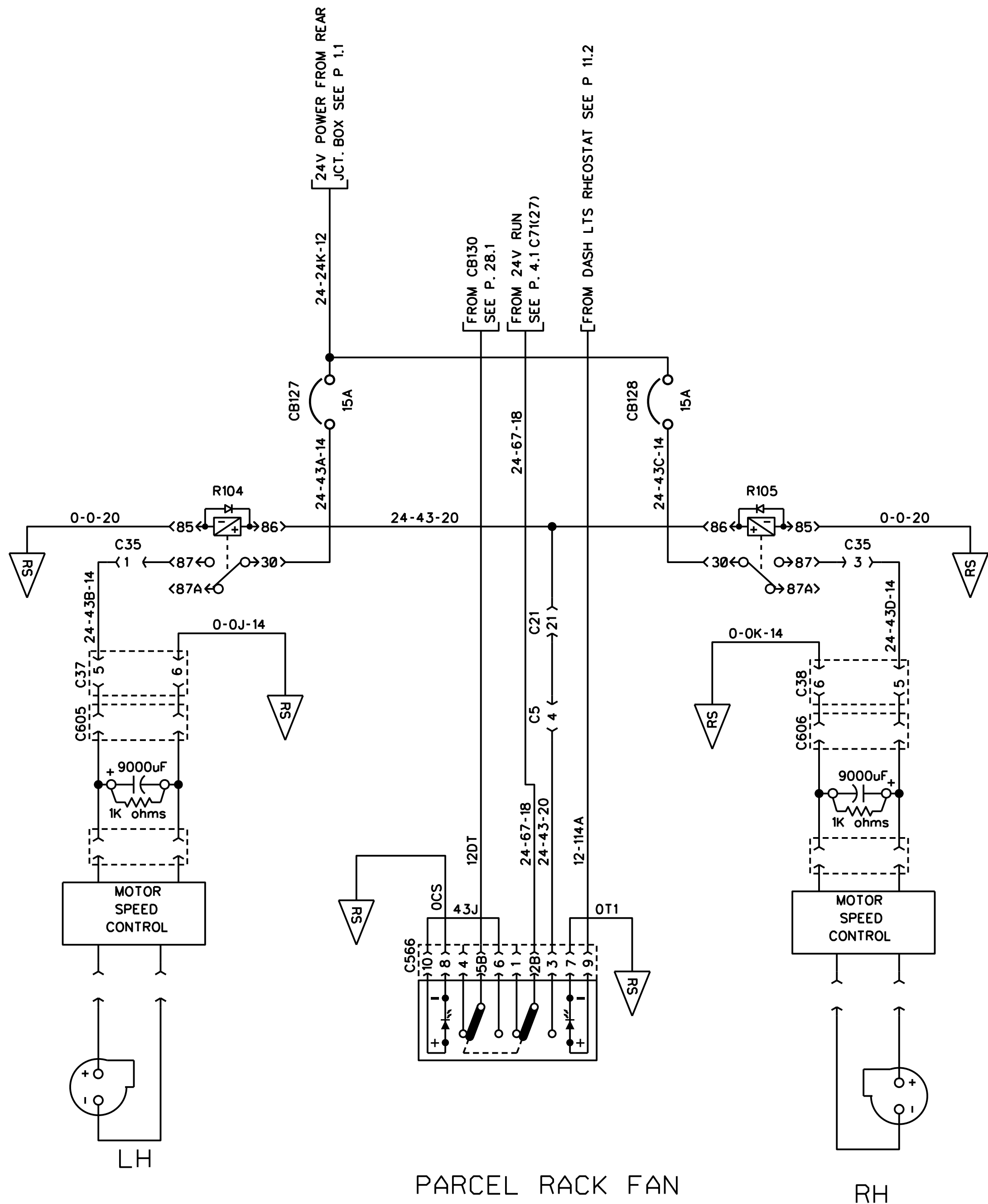

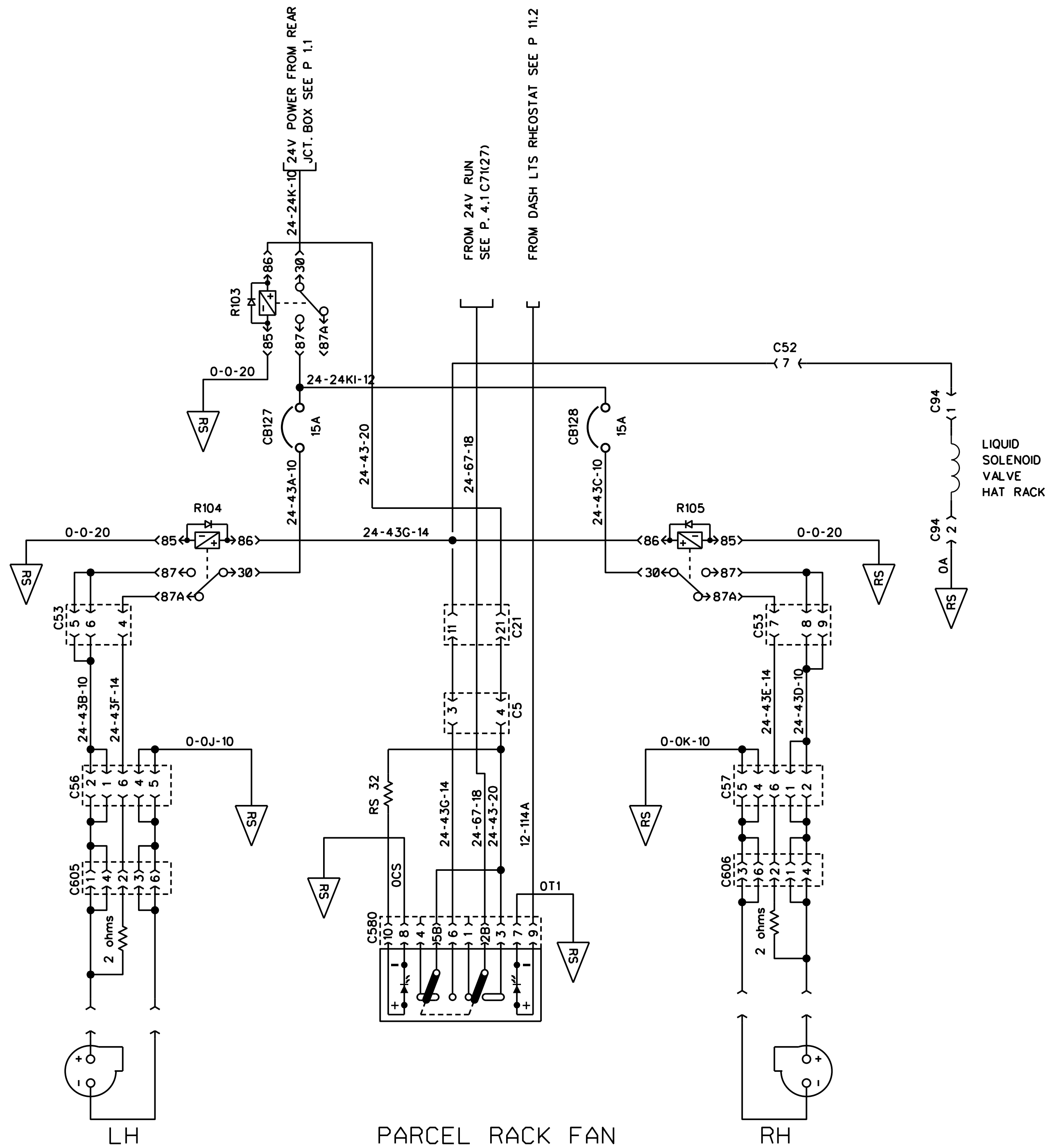

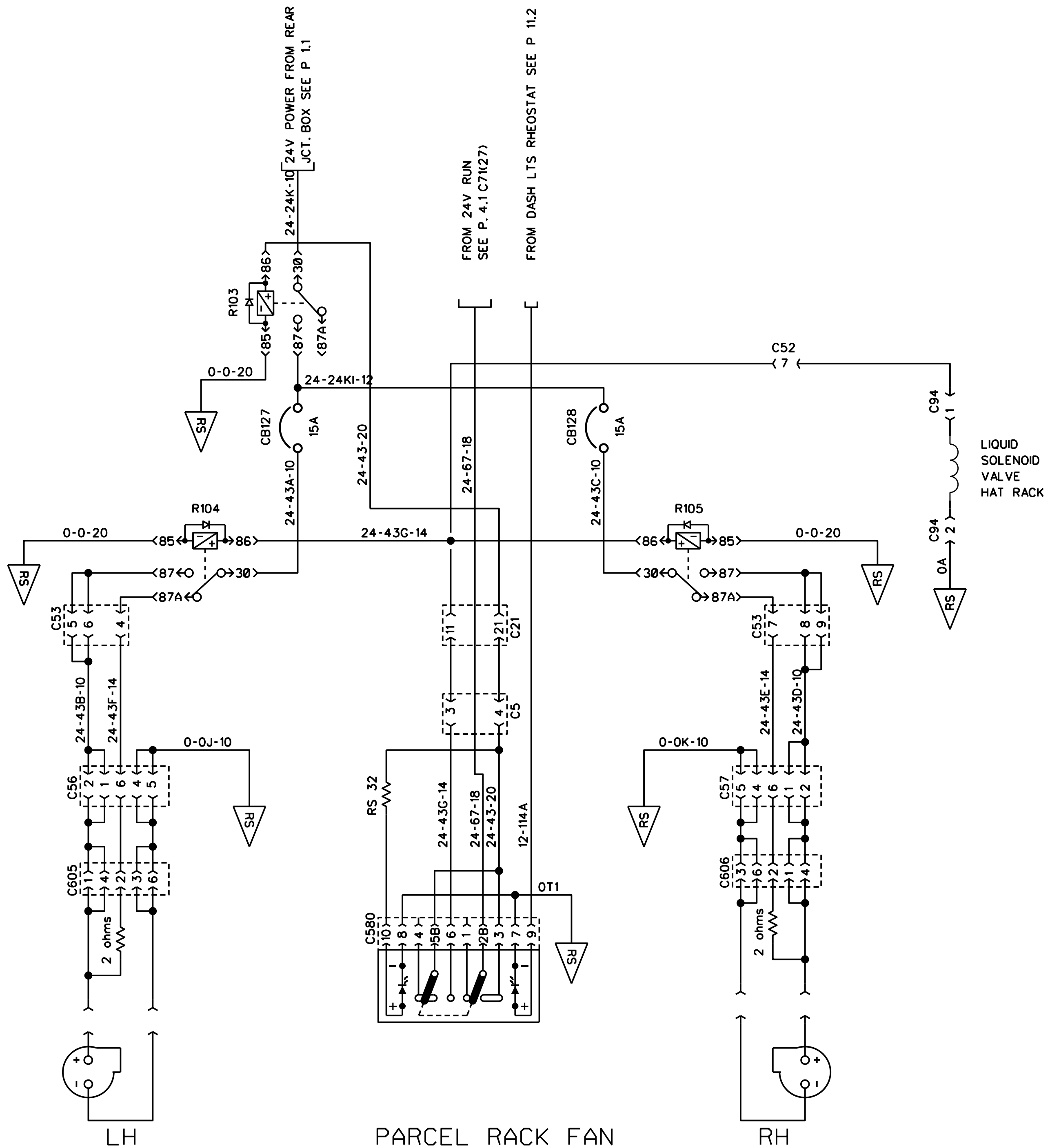



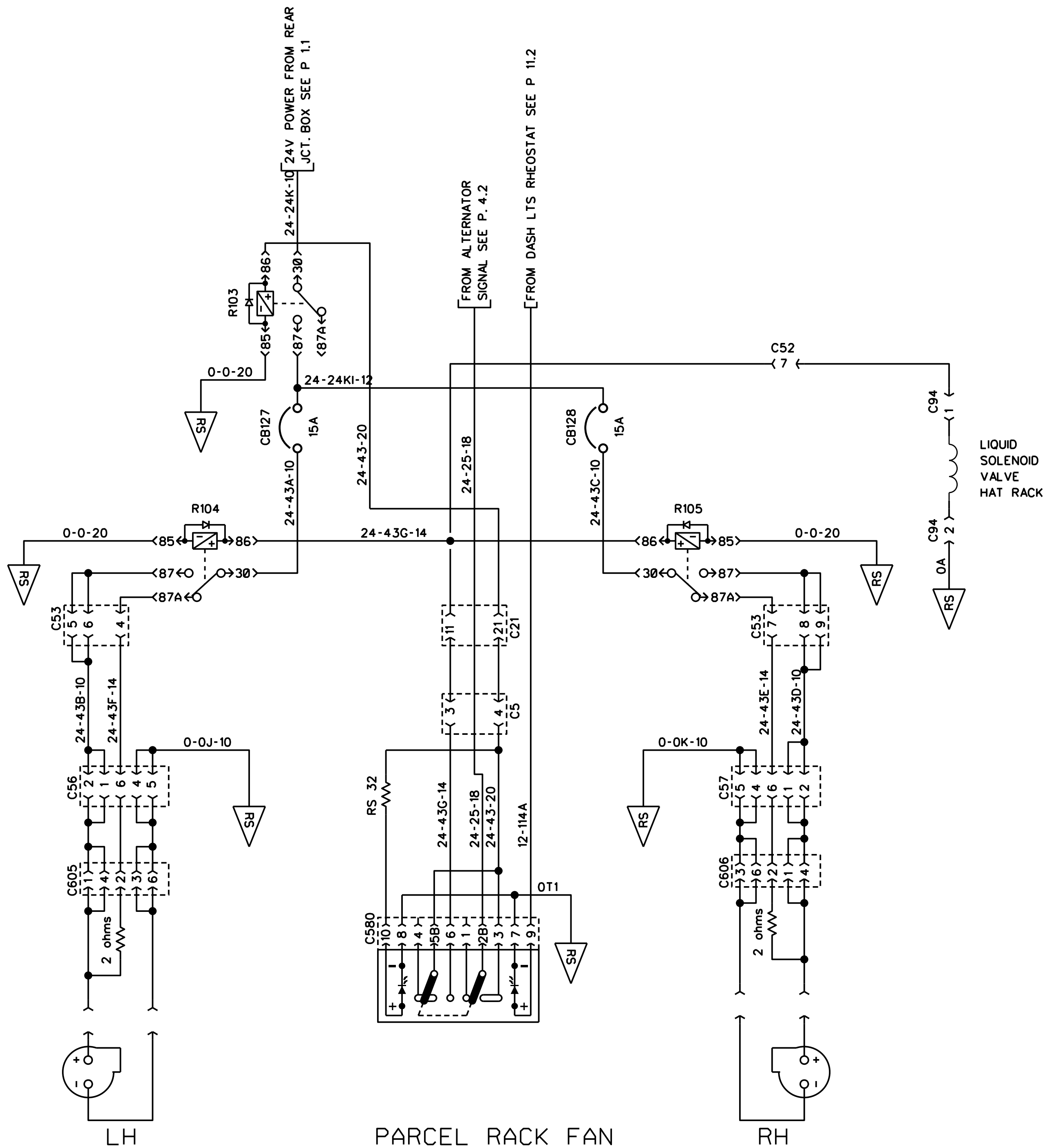

( CENTRAL MODULE )  
( R.H. DRAWER )

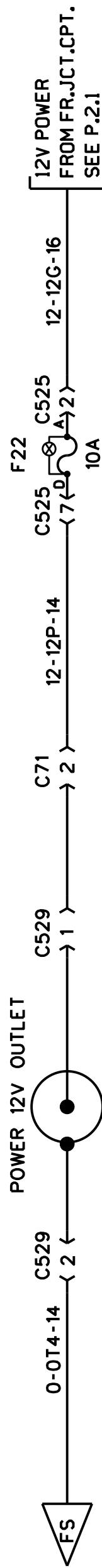

POWER 12V OUTLET

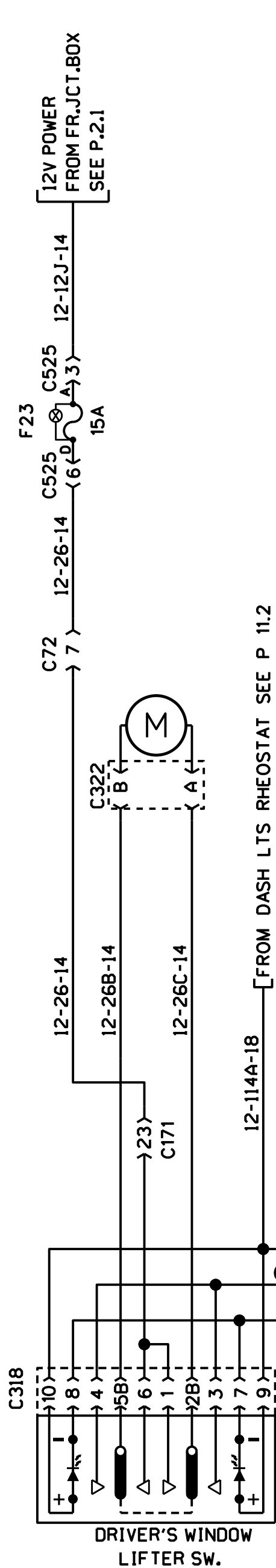

DRIVER'S WINDOW LIFTER

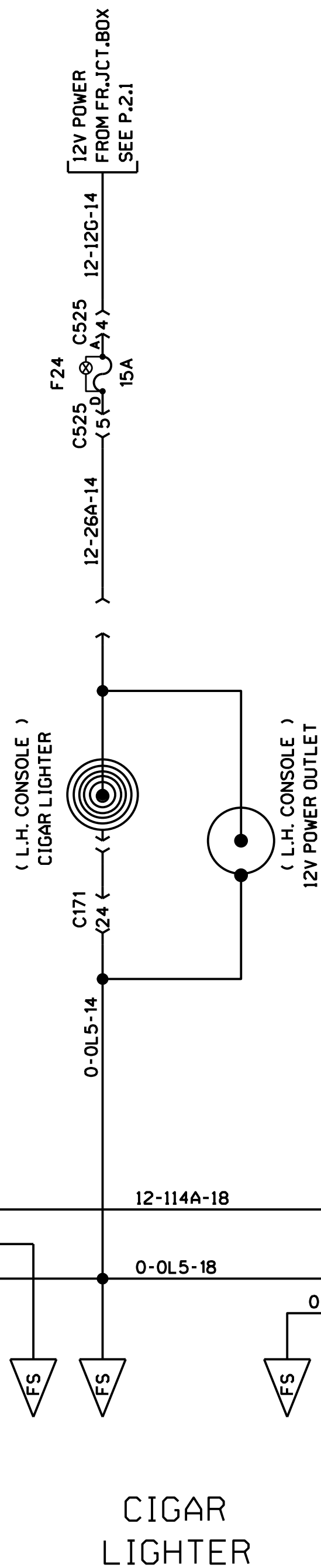

CIGAR LIGHTER

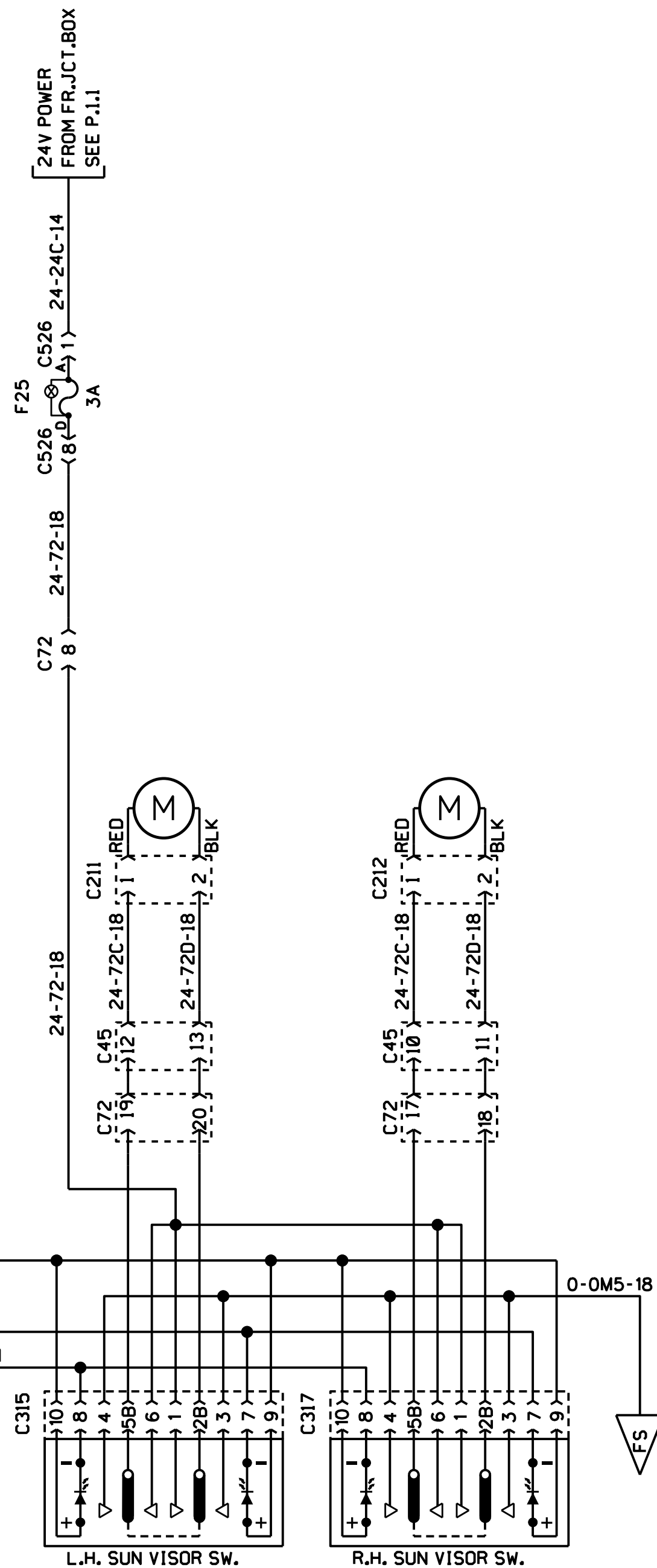

SUN VISOR

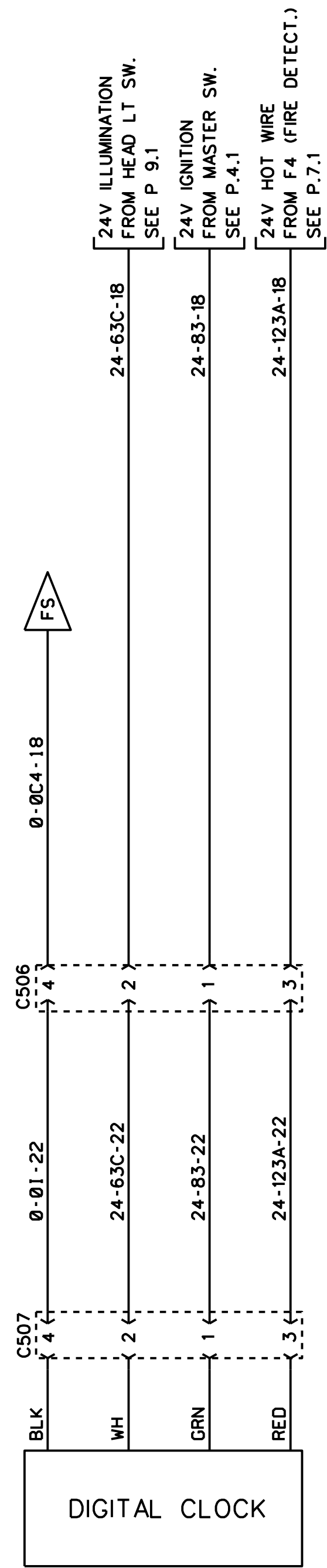

DIGITAL CLOCK

( CENTRAL MODULE )  
( R.H. DRAWER )

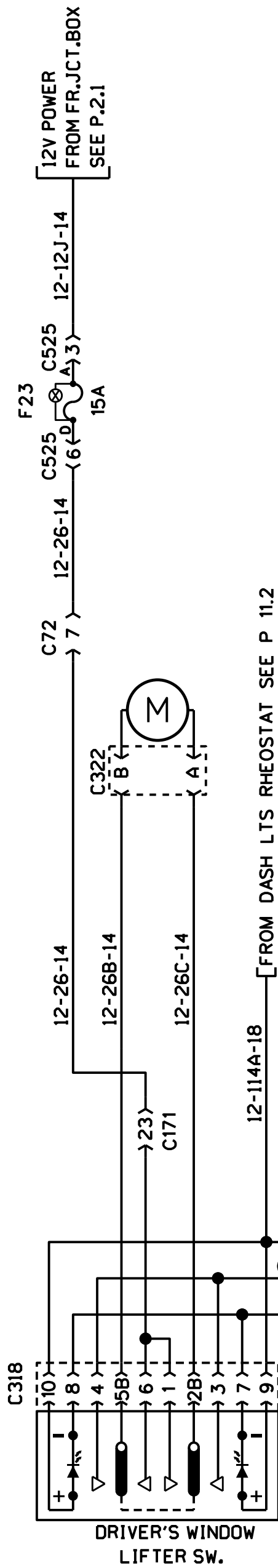
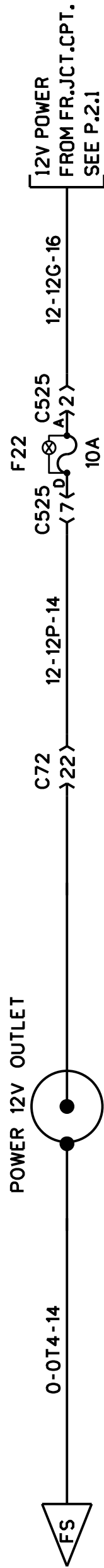

[FROM DASH LTS RHEOSTAT SEE P 11.2]

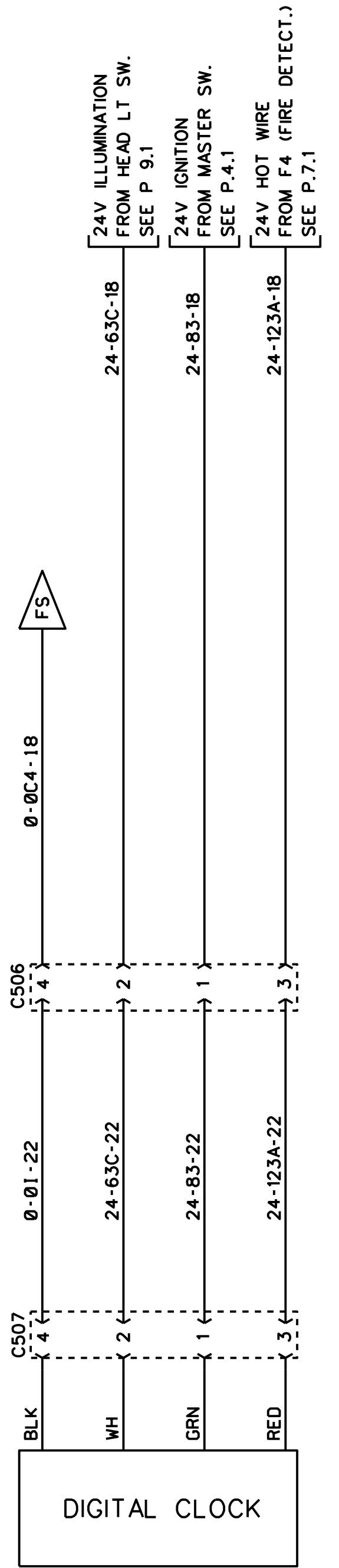
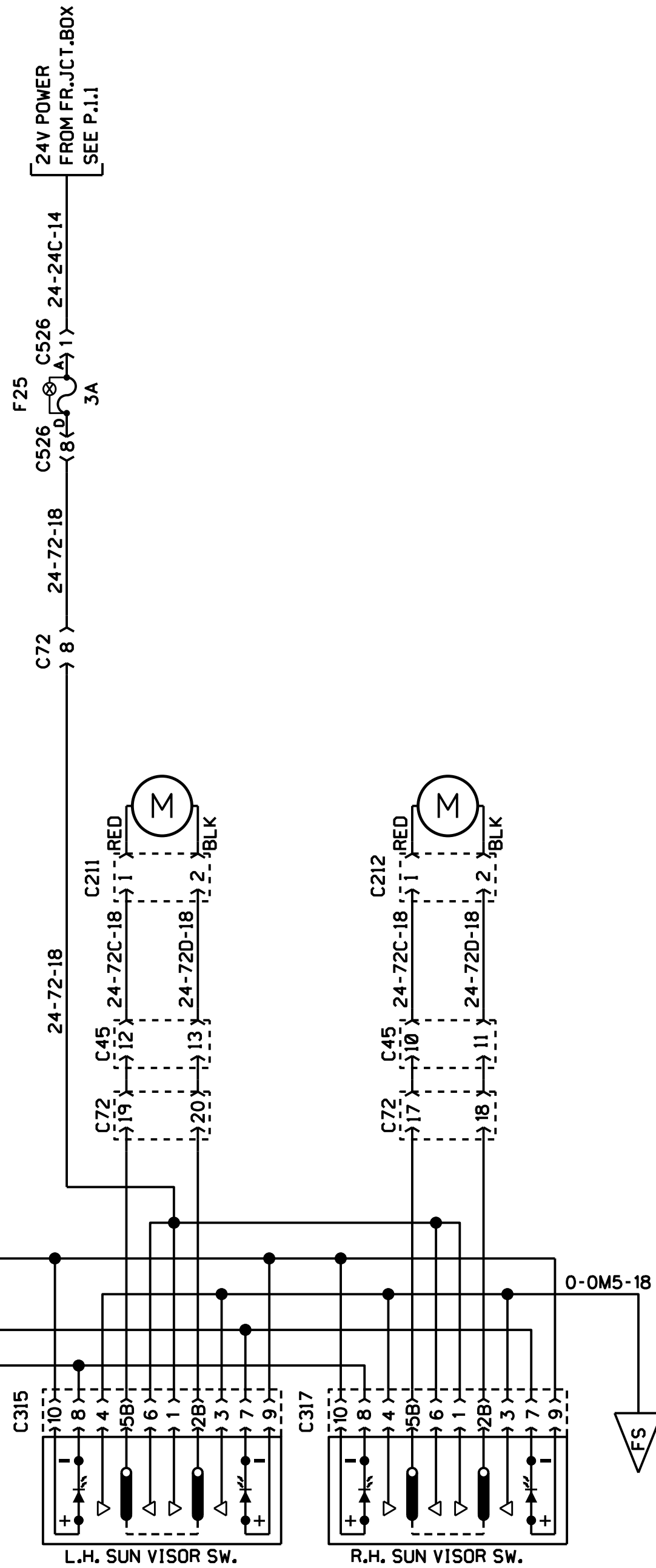
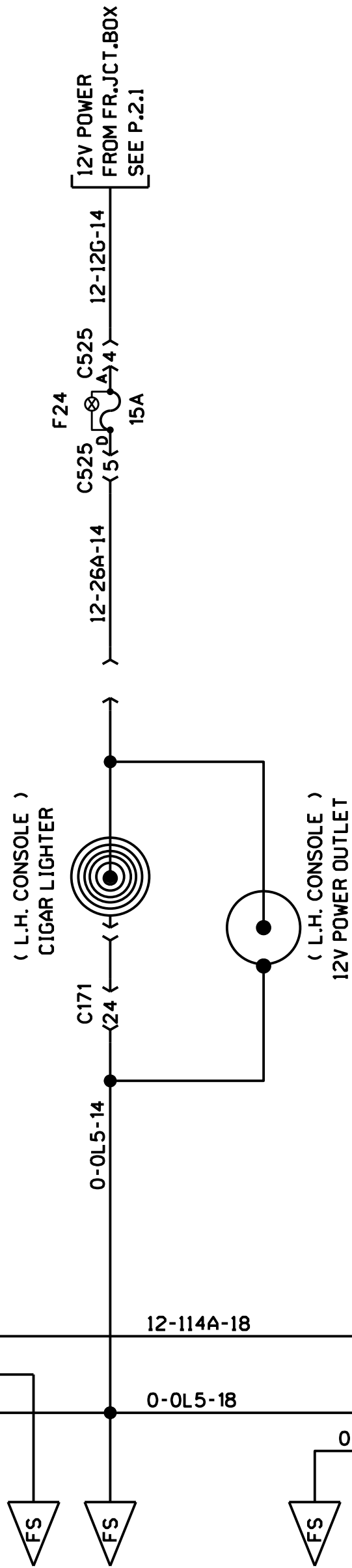

POWER 12V OUTLET

DRIVER'S WINDOW LIFTER

CIGAR LIGHTER

SUN VISOR

DIGITAL CLOCK

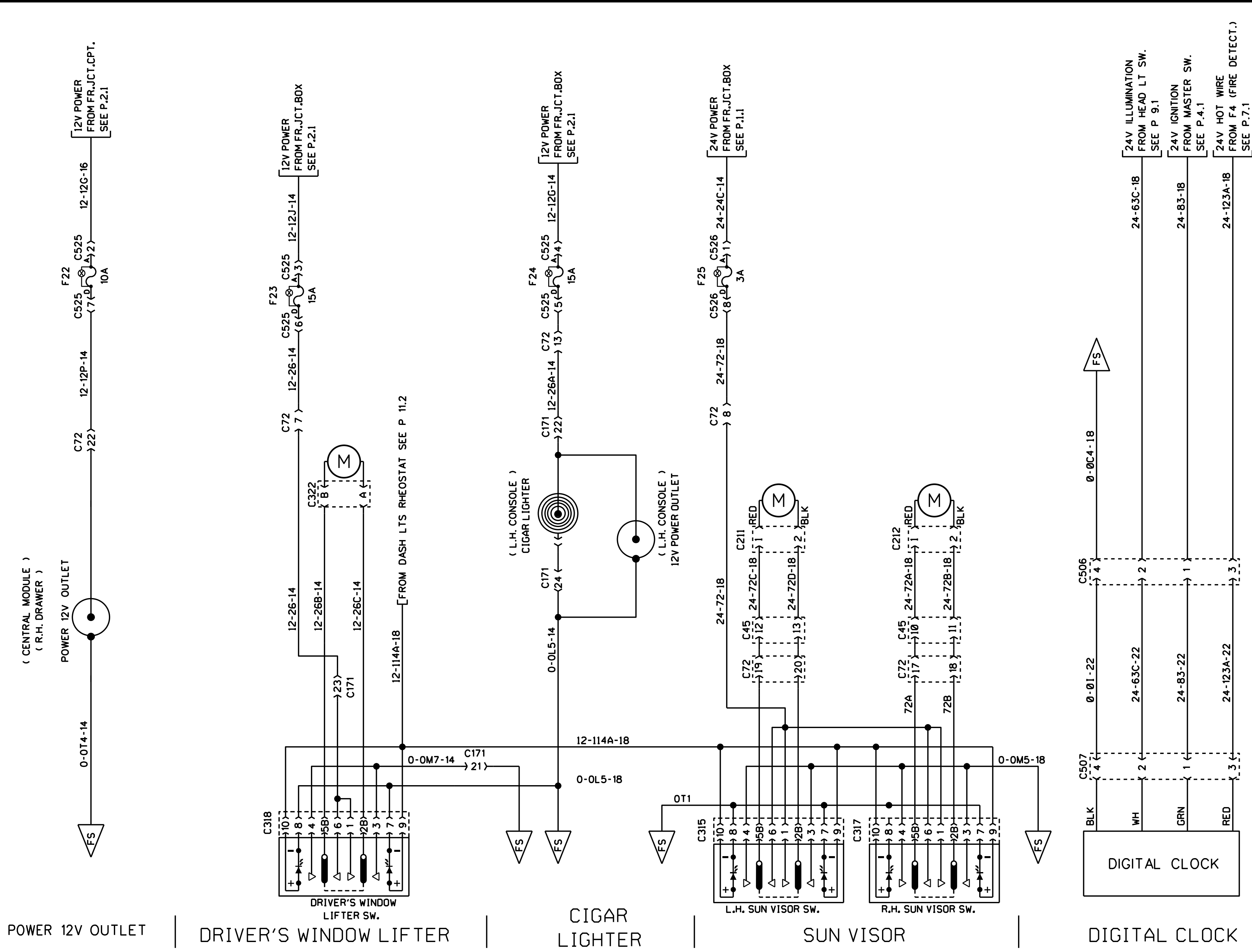

TO WATER HEATER TIMER  
SEE P. 26

C71 → 28 → 24-127-16 C526 F26 C526 → 7 → 24-24D-16 → 24V H.W. POWER FROM FR. JCT. BOX SEE P. 1.1

5A

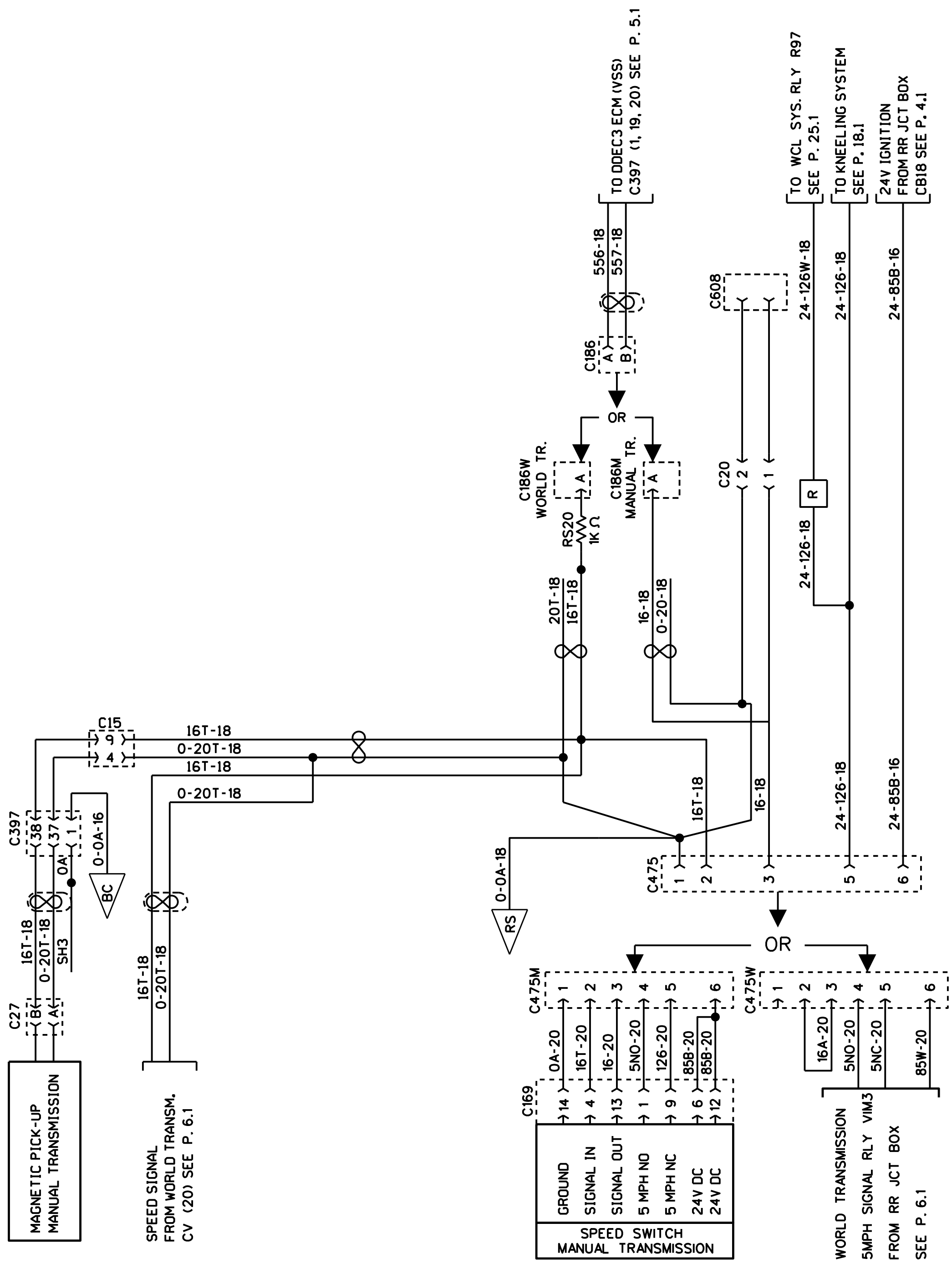

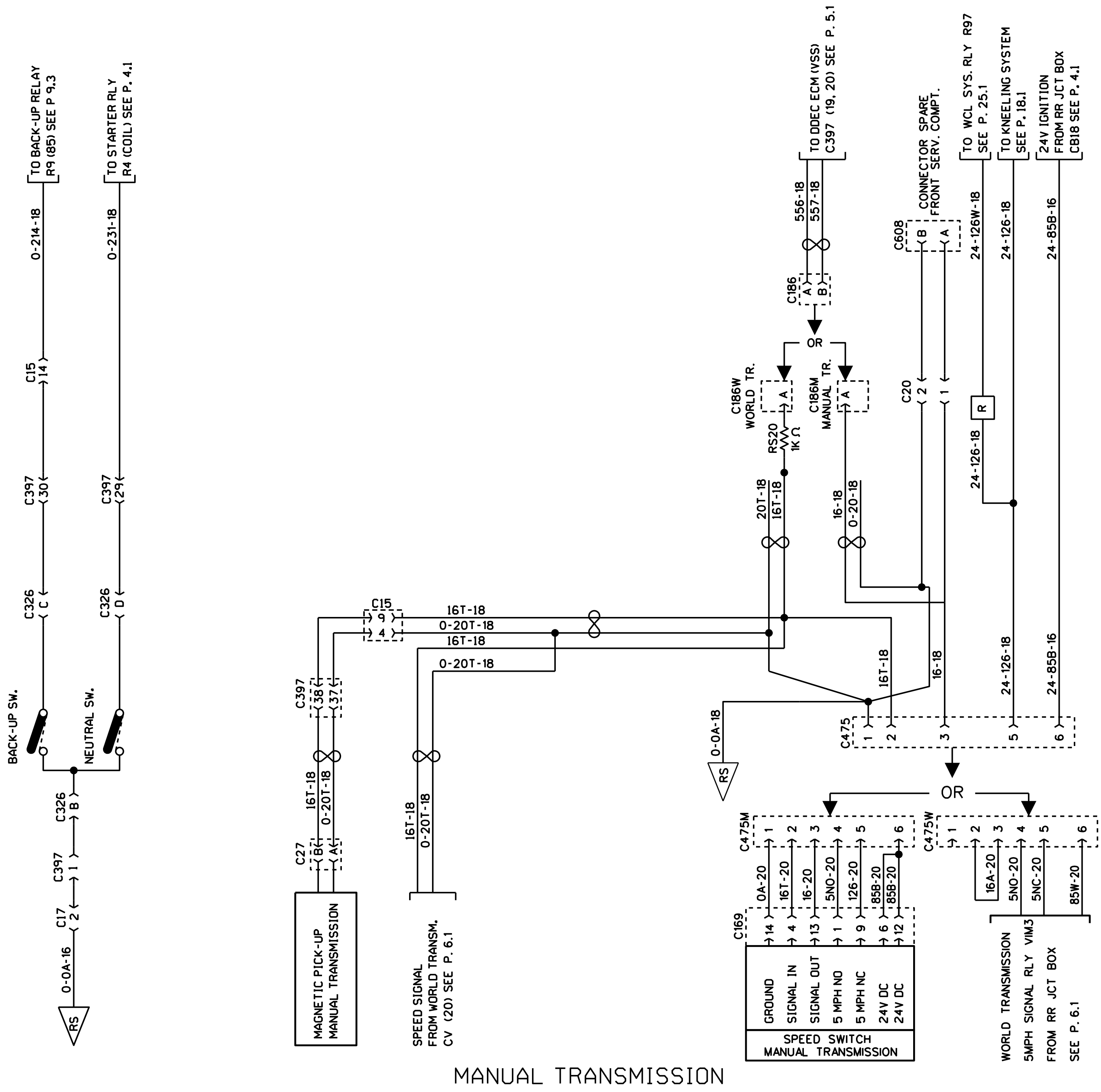

MANUAL TRANSMISSION

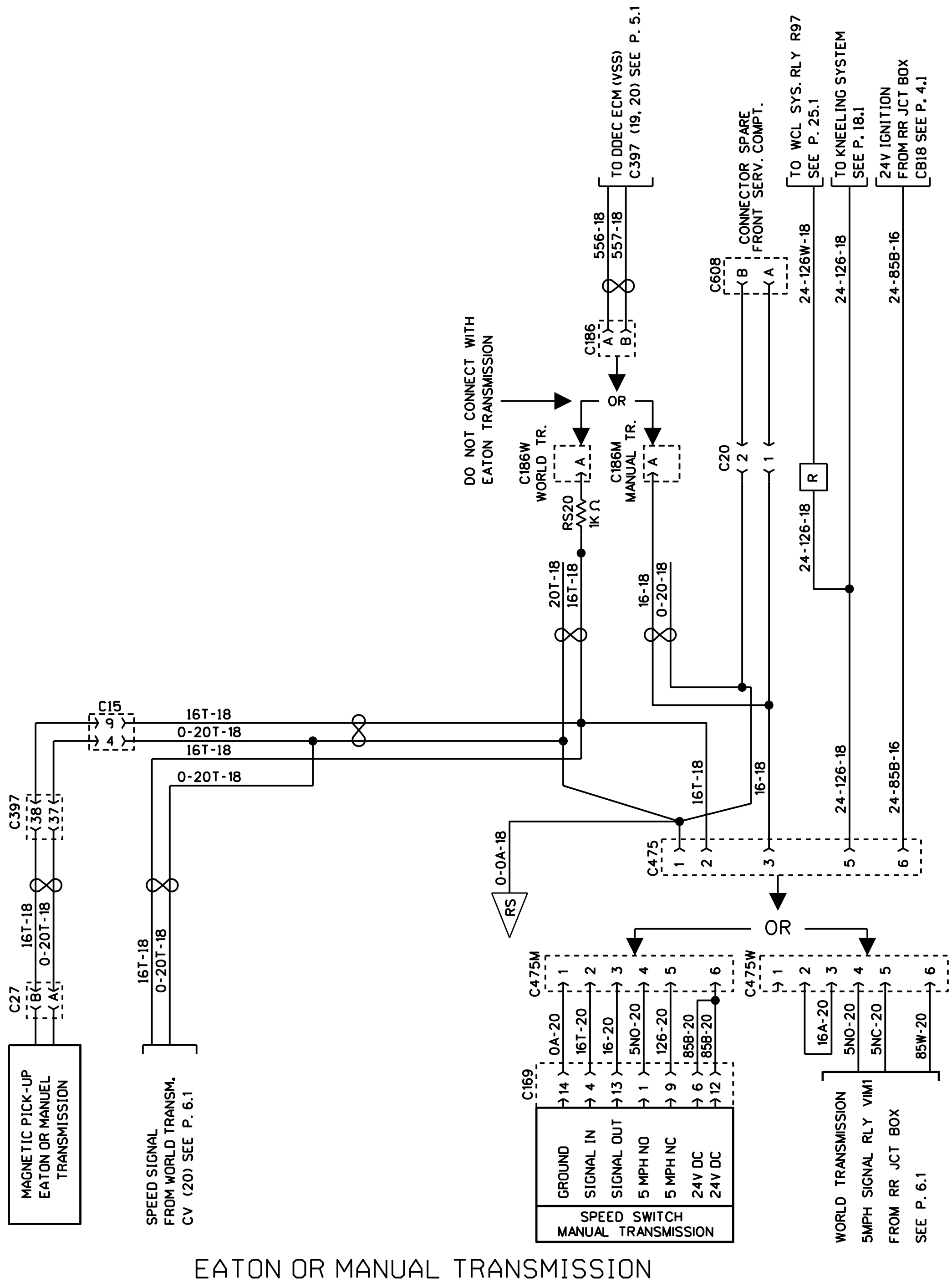
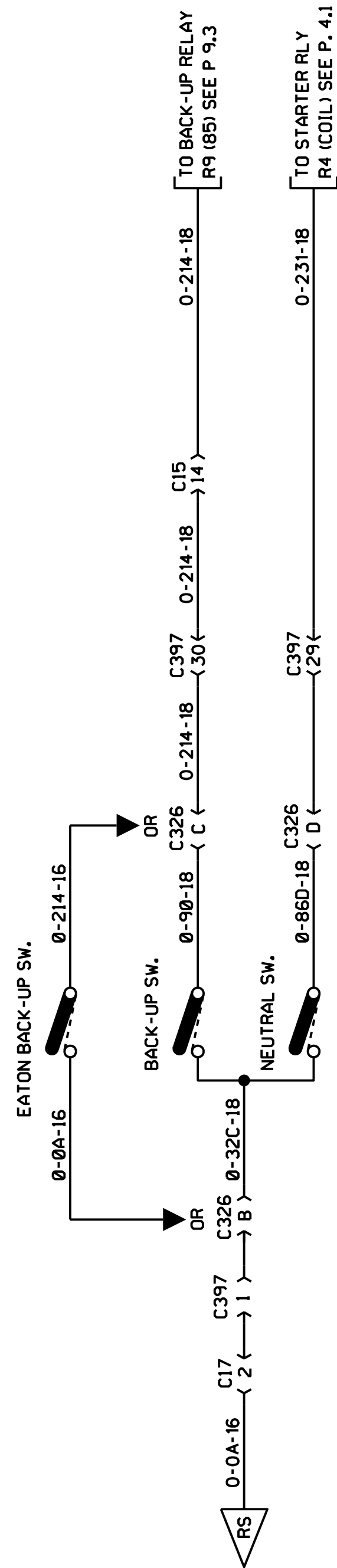

EATON OR MANUAL TRANSMISSION



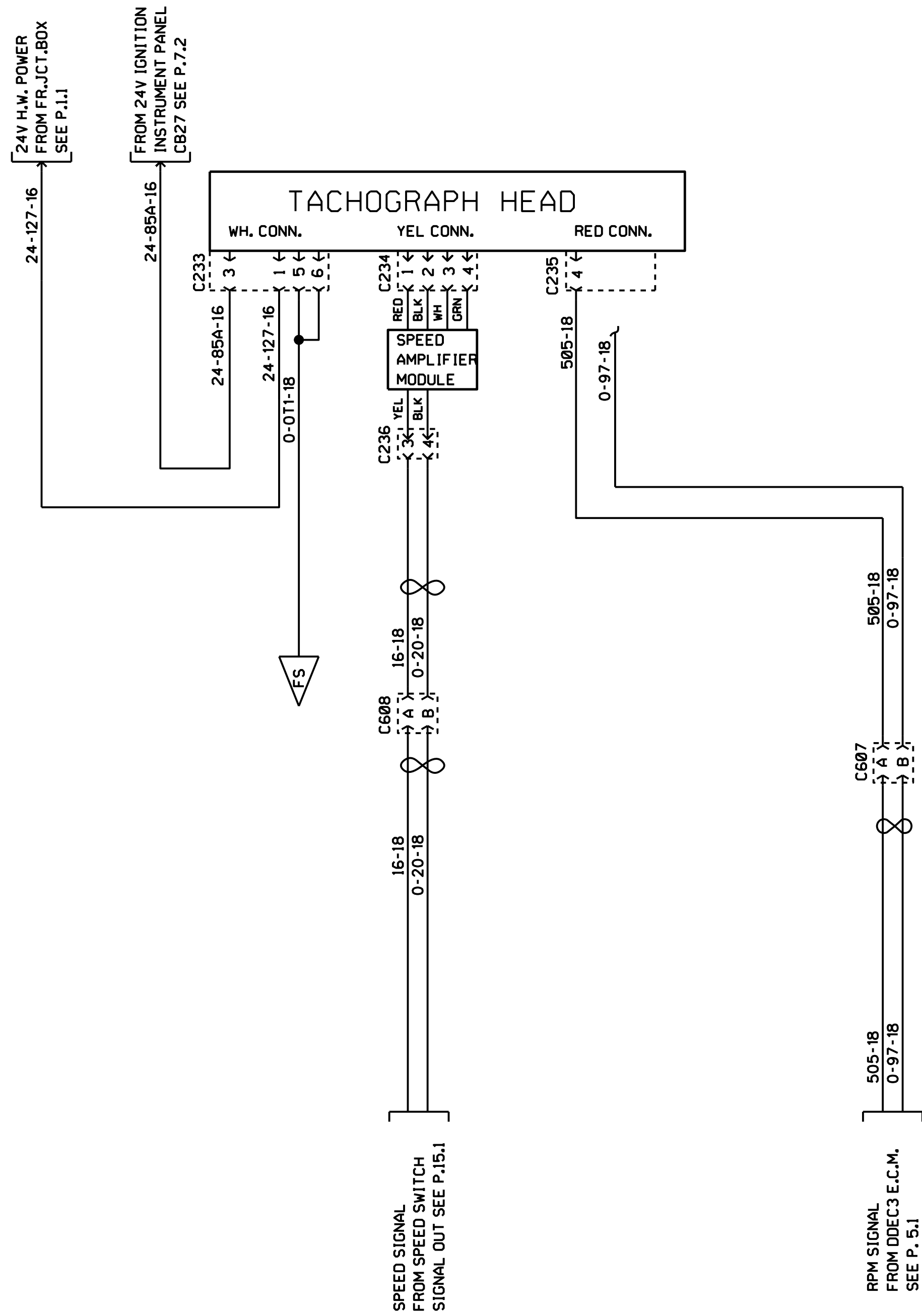

ELECTRONIC TACHOGRAPH

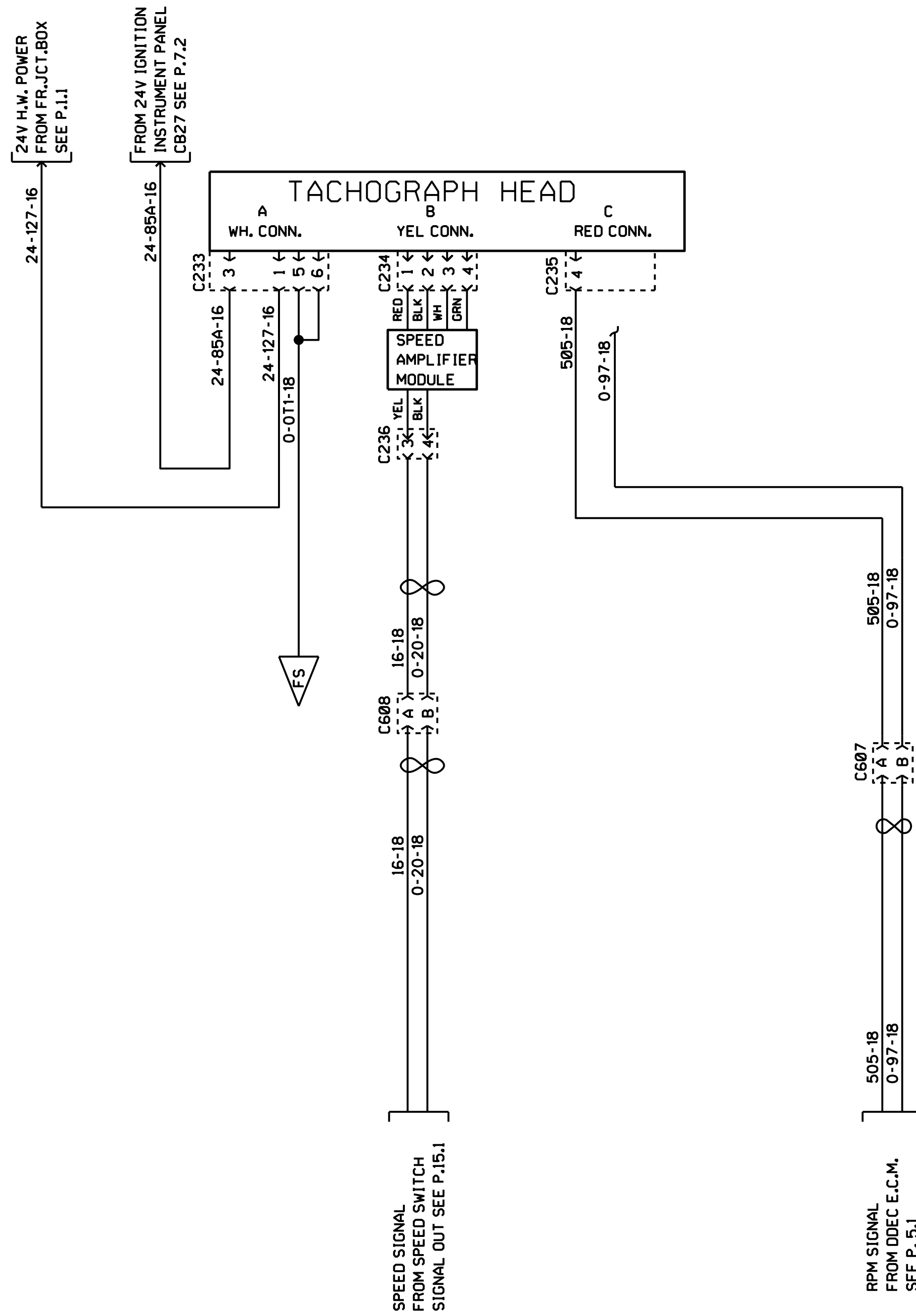

ELECTRONIC TACHOGRAPH

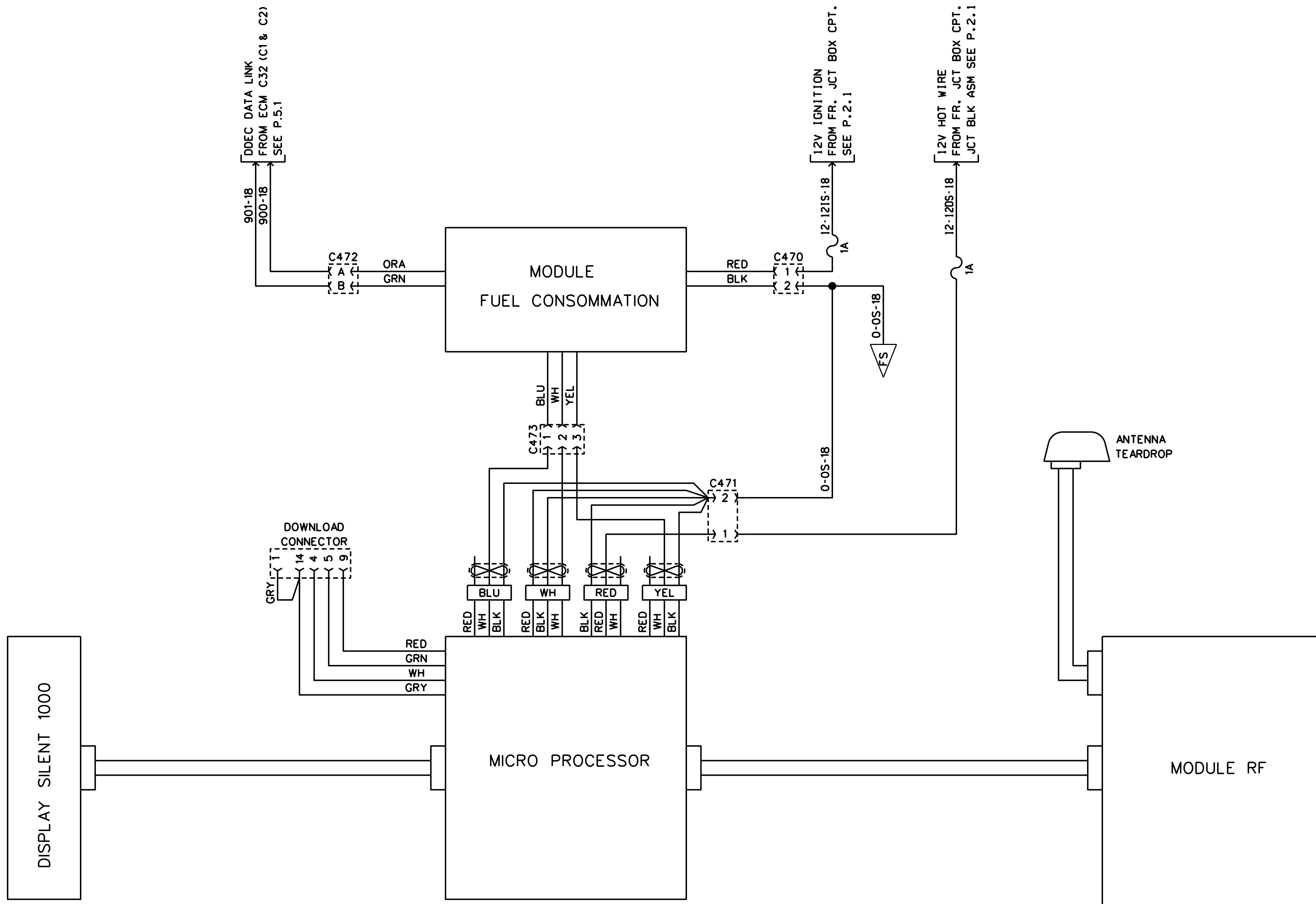

SILENT 1000

[FROM DASH LTS RHEOSTAT SEE P 11.2

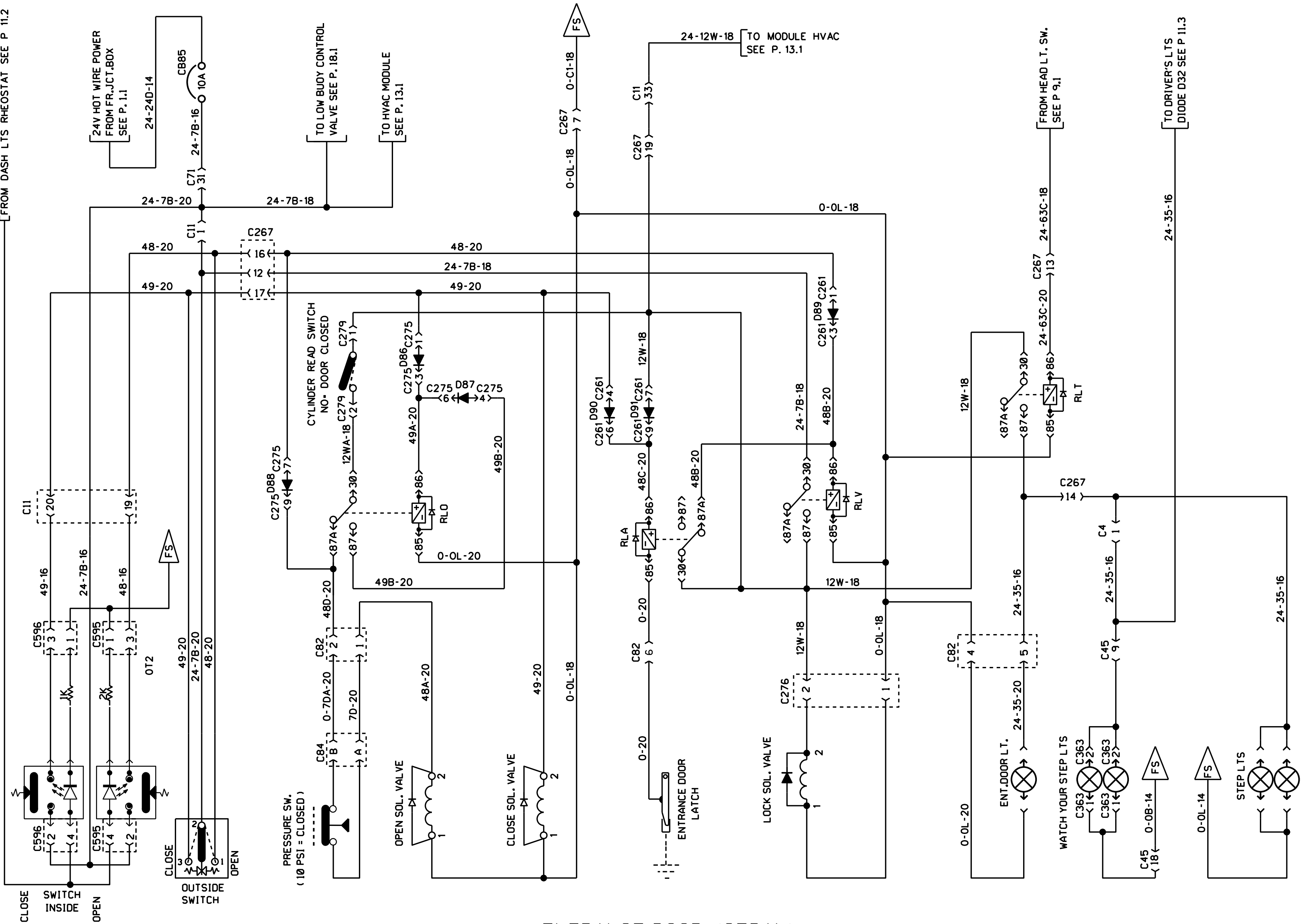

ENTRANCE DOOR (SEDAN)

[FROM DASH LTS RHEOSTAT SEE P 11.2

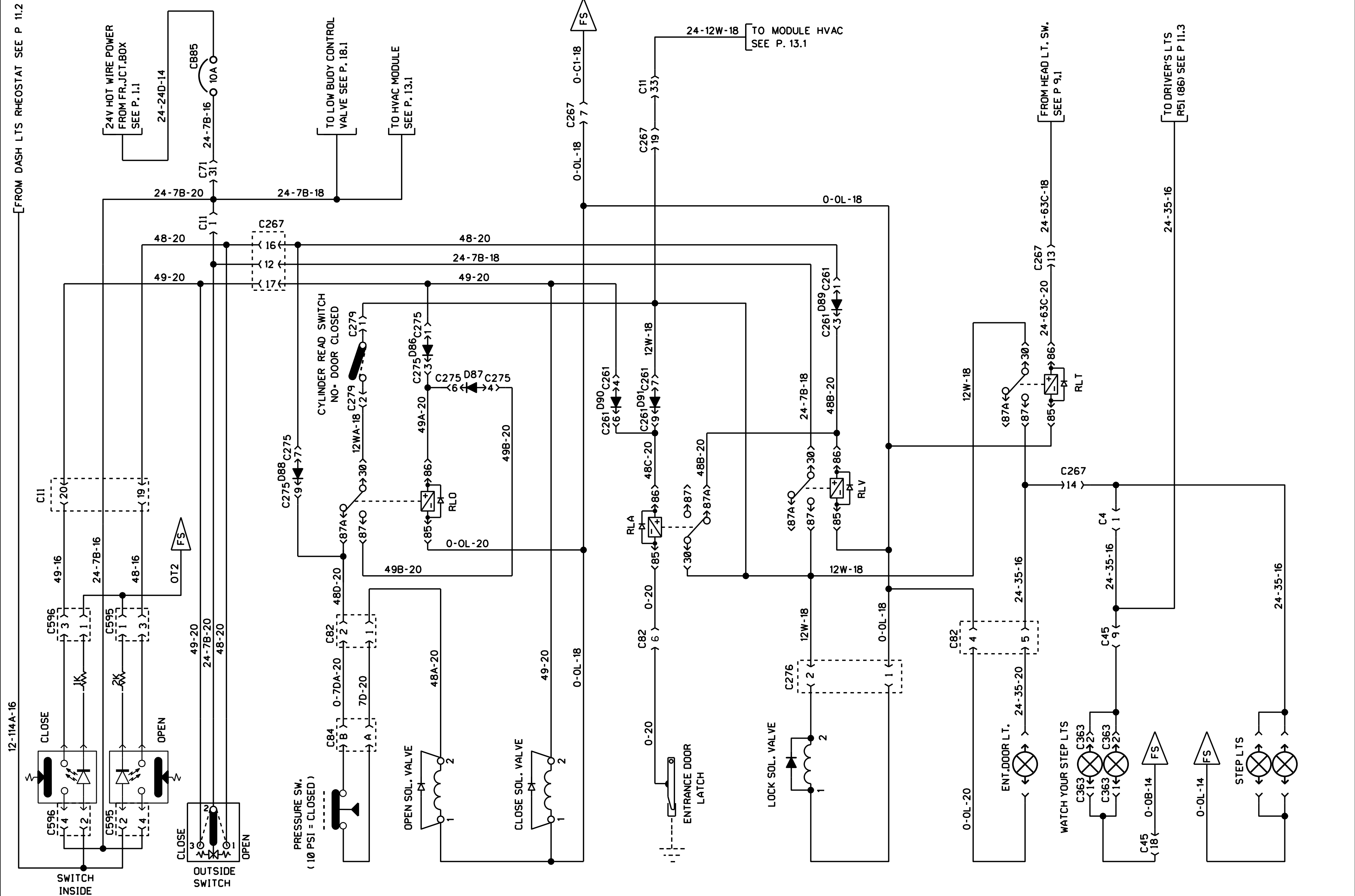

ENTRANCE DOOR (SEDAN)

[FROM DASH LTS RHEOSTAT SEE P 11.2

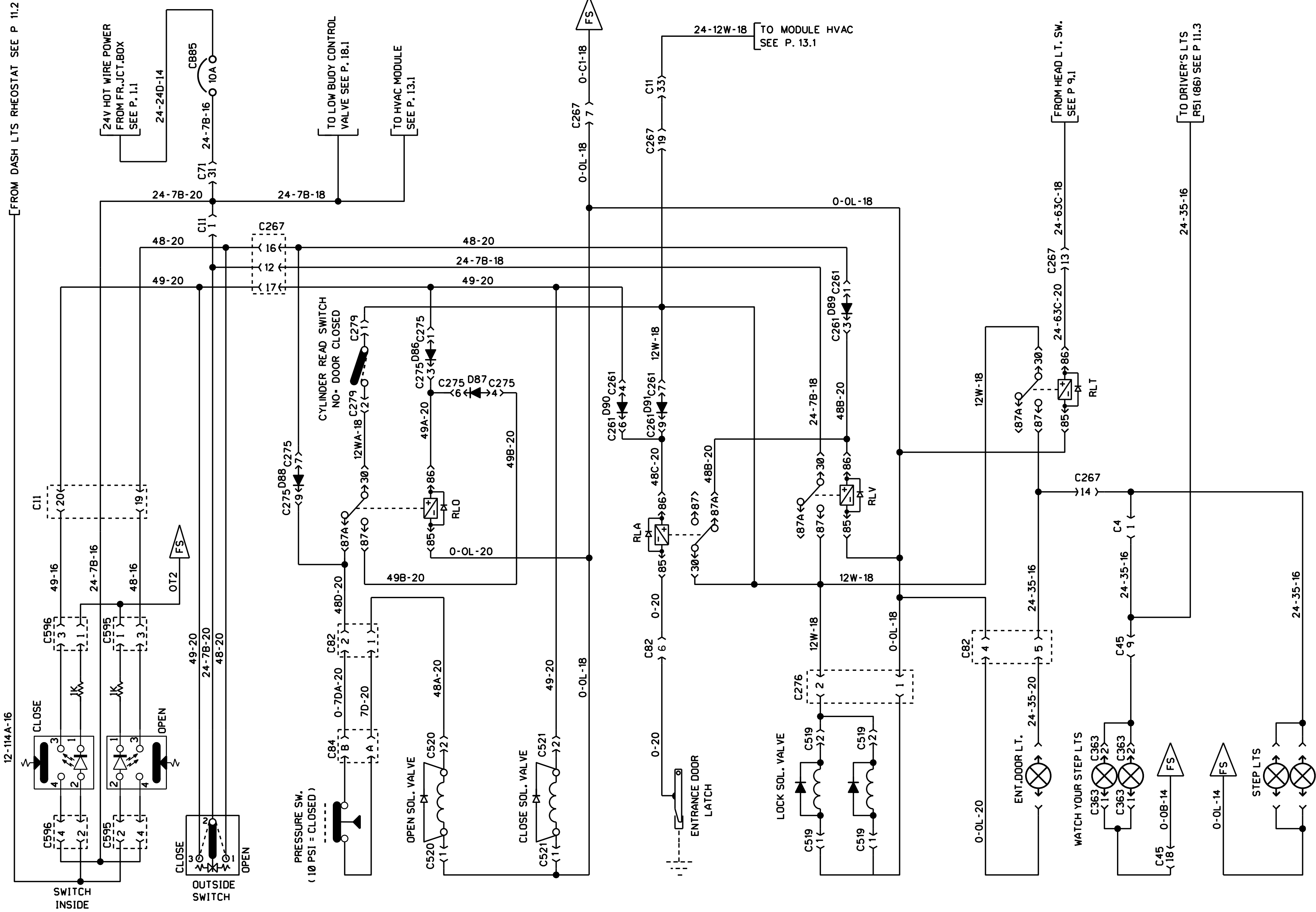

ENTRANCE DOOR (SEDAN)

[FROM DASH LTS RHEOSTAT SEE P 11.2

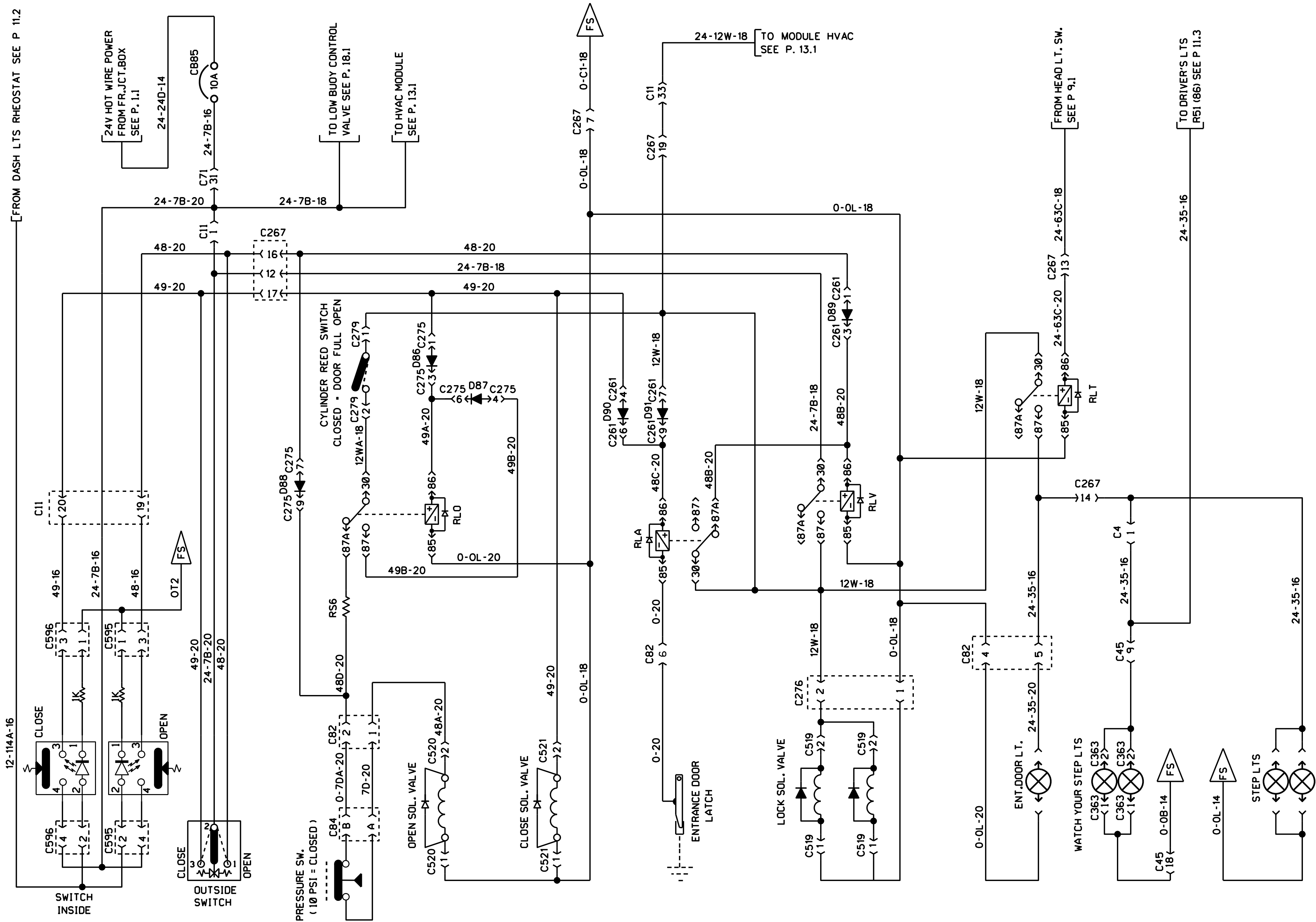

ENTRANCE DOOR (SEDAN)



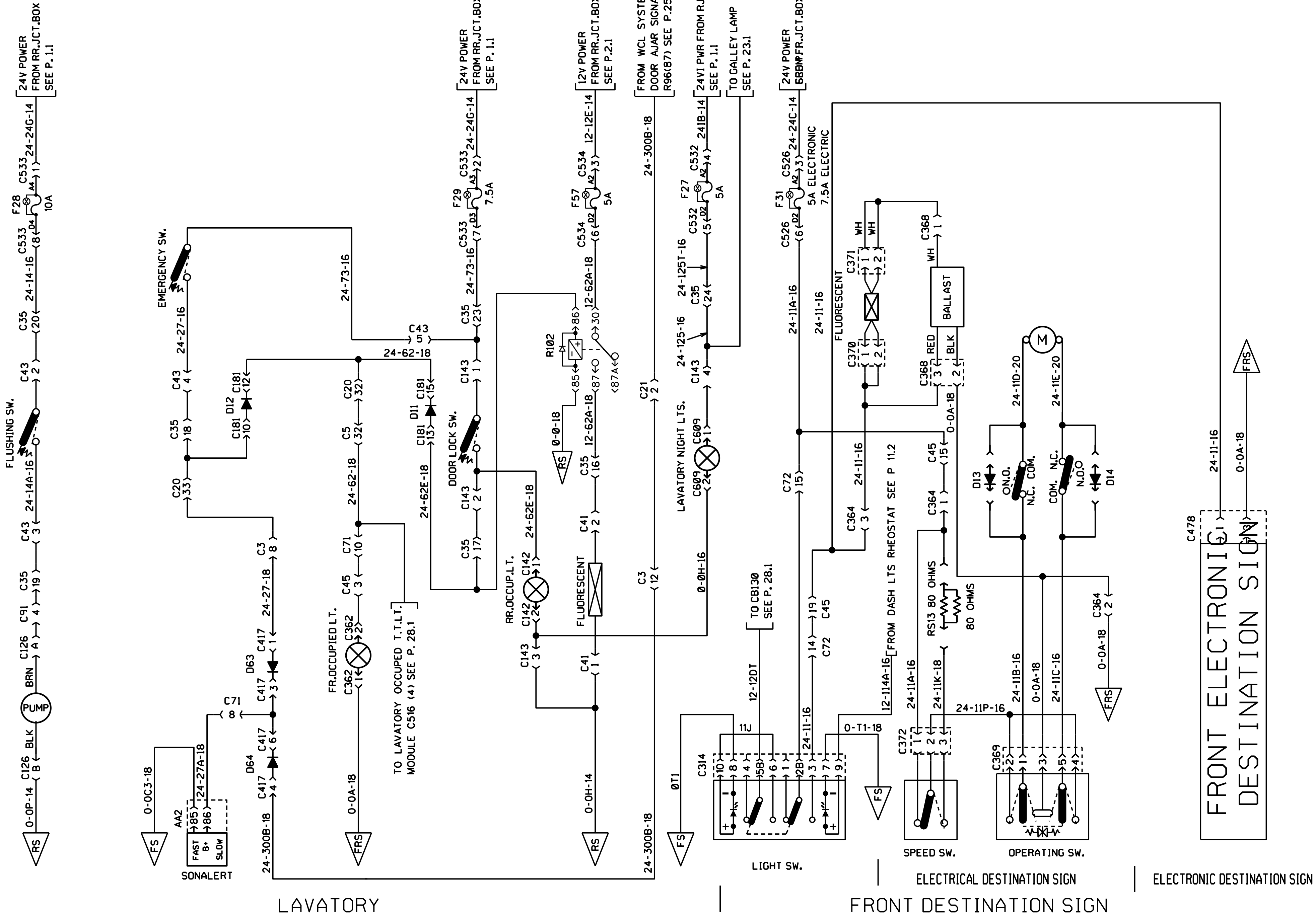

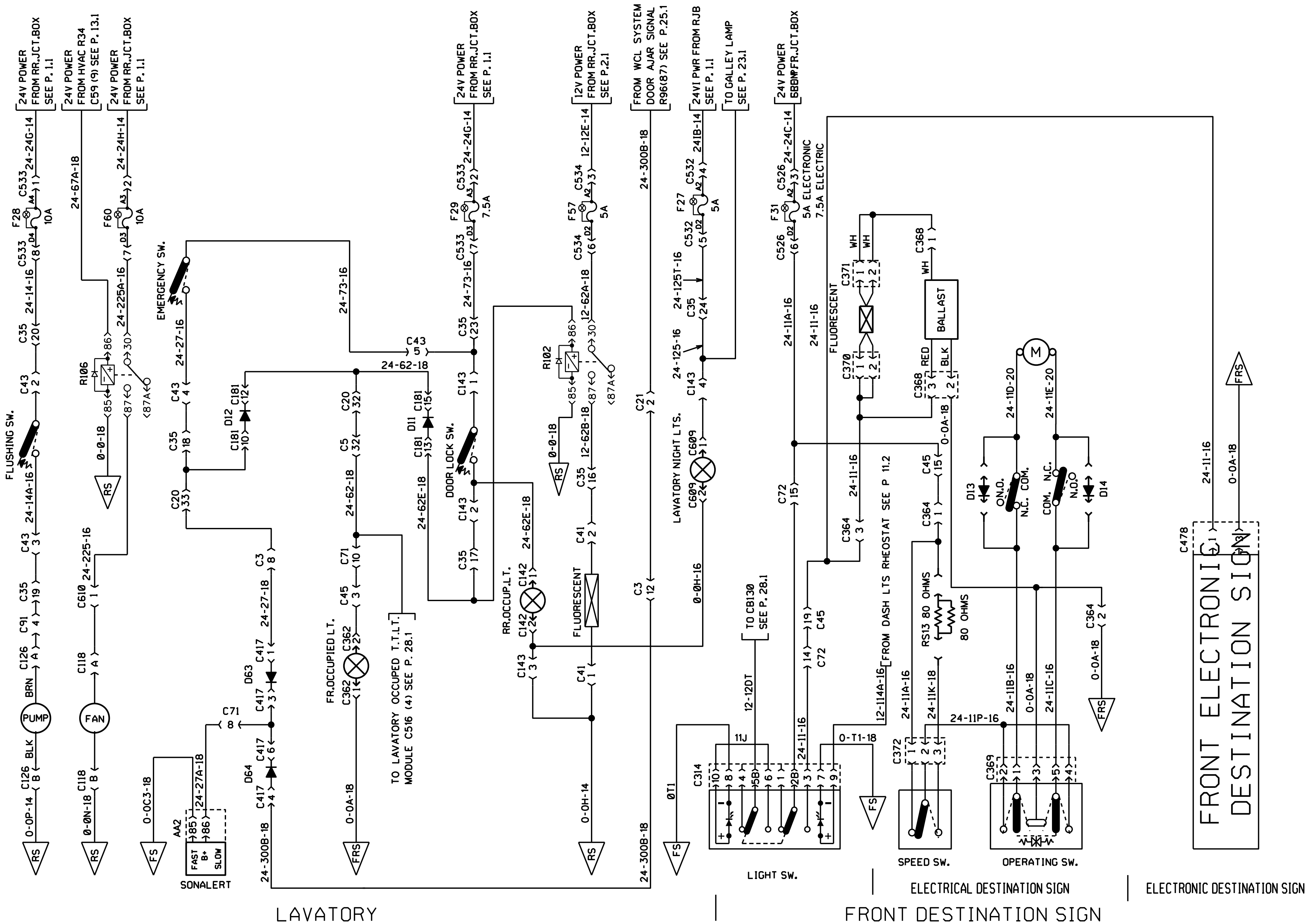

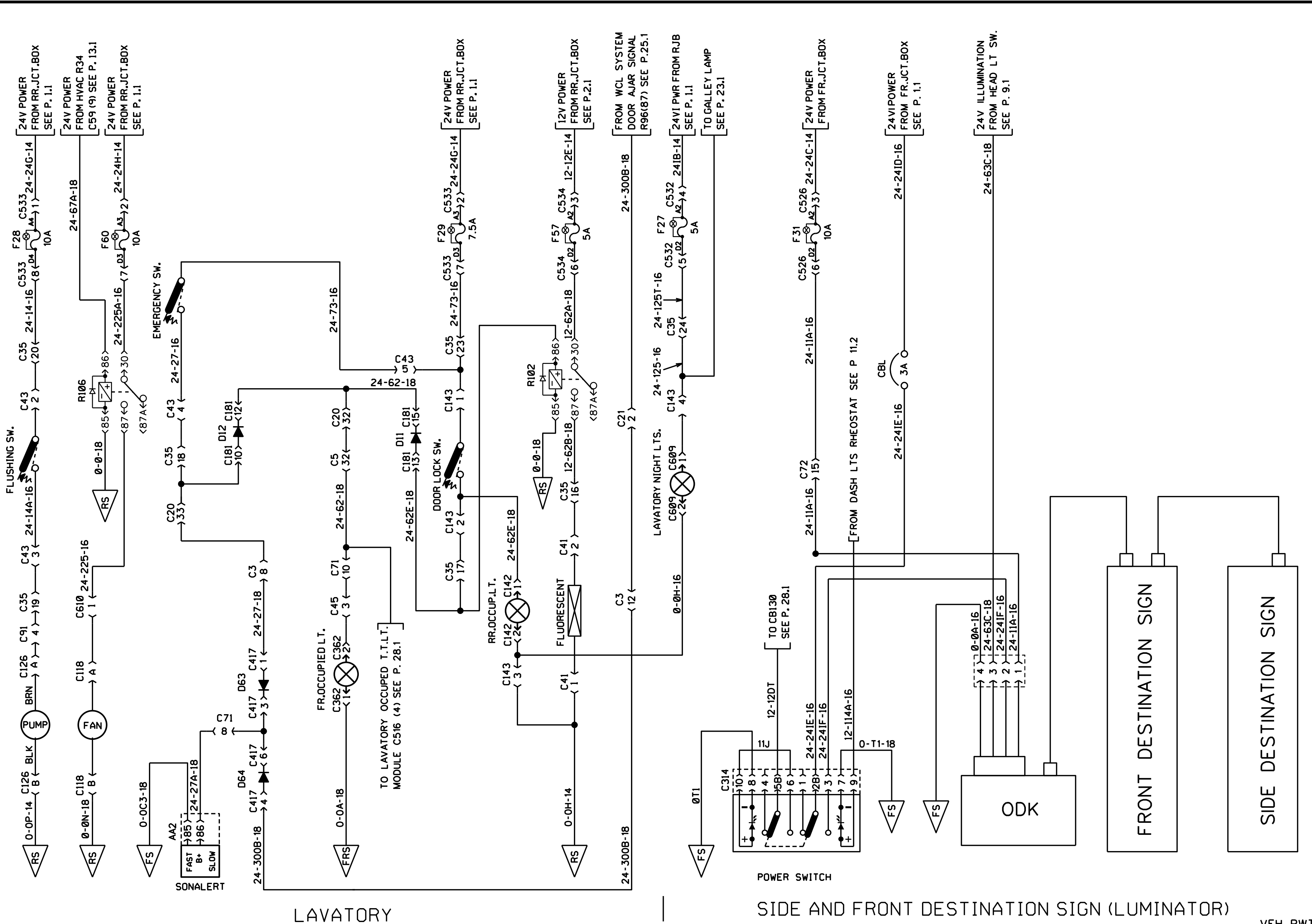

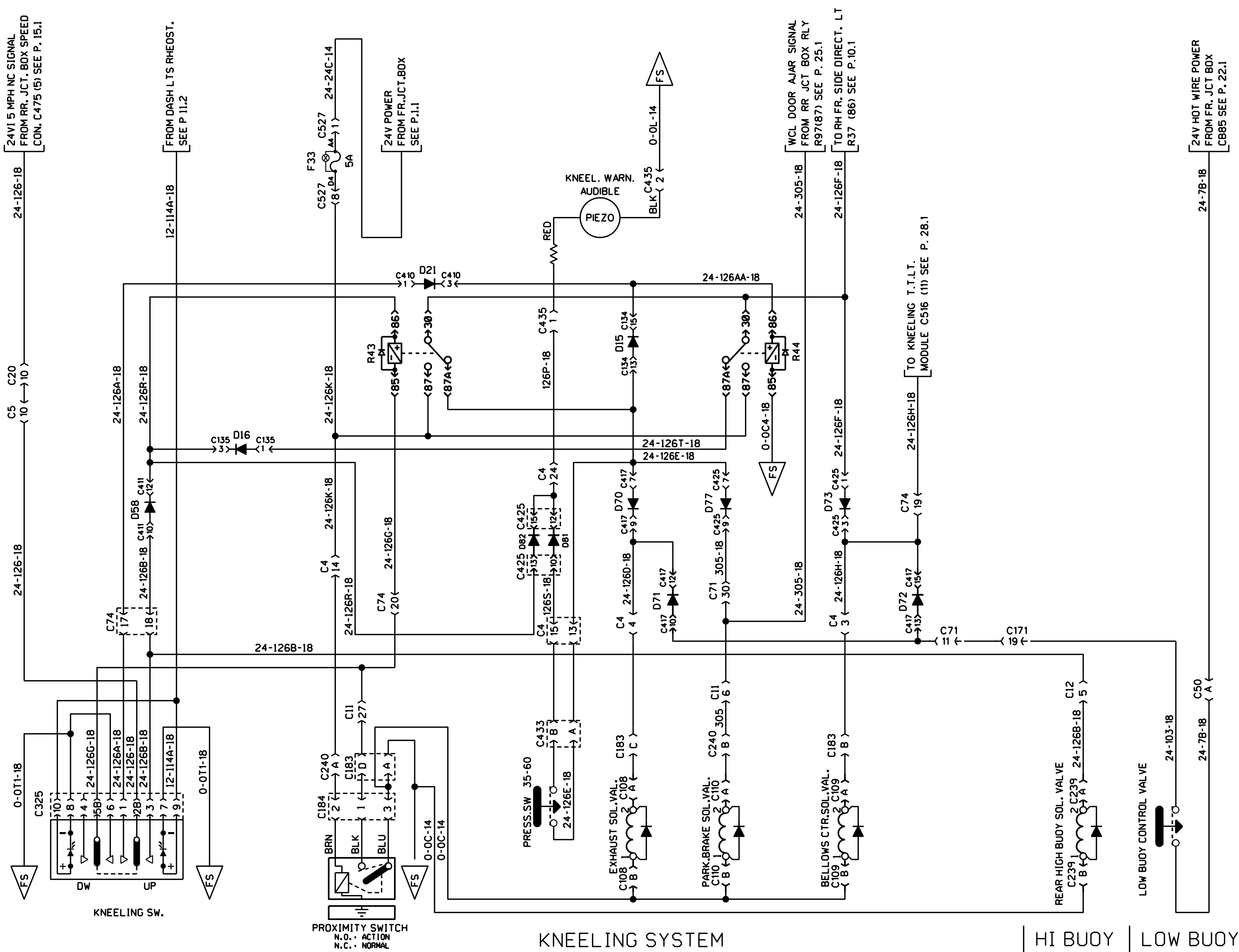

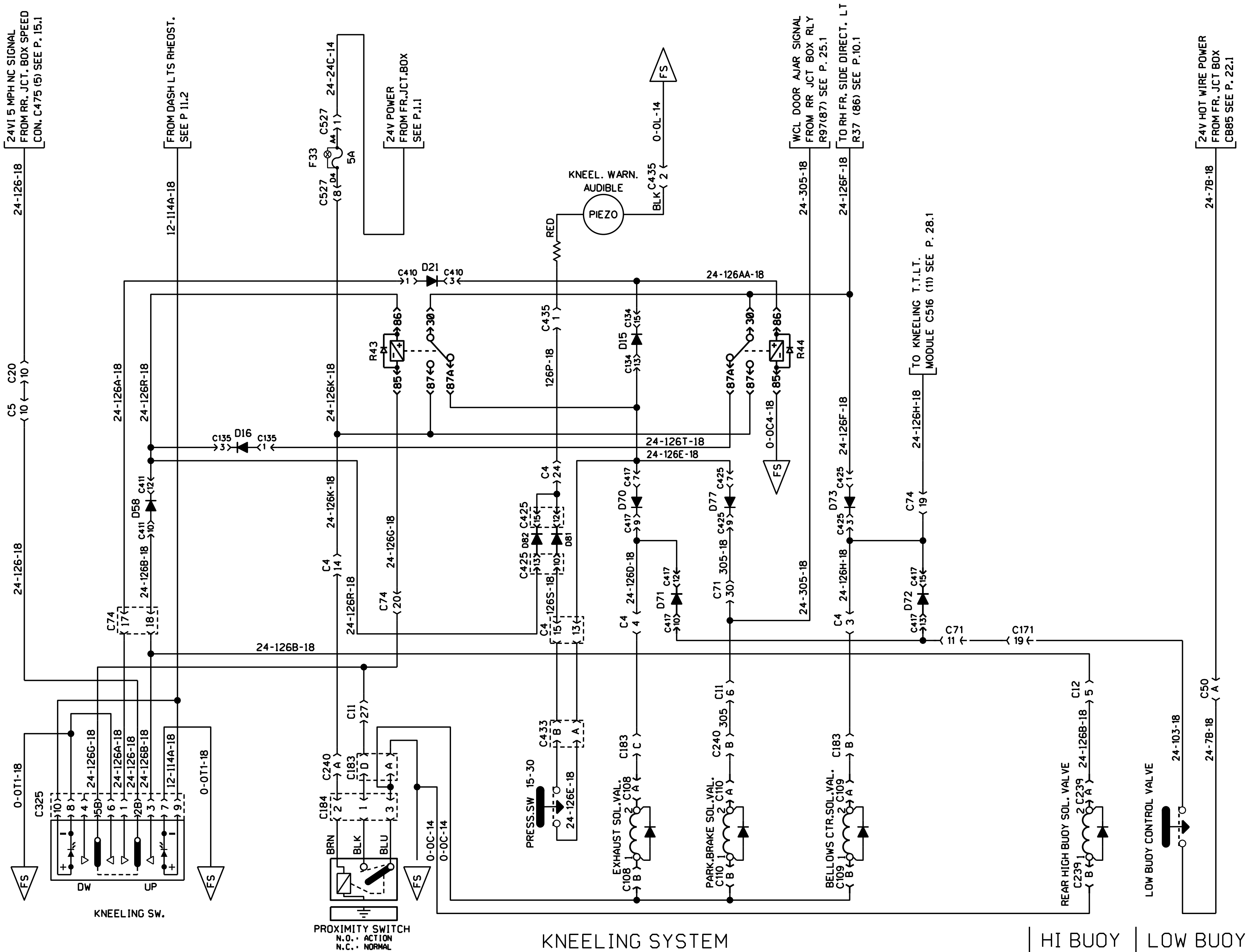

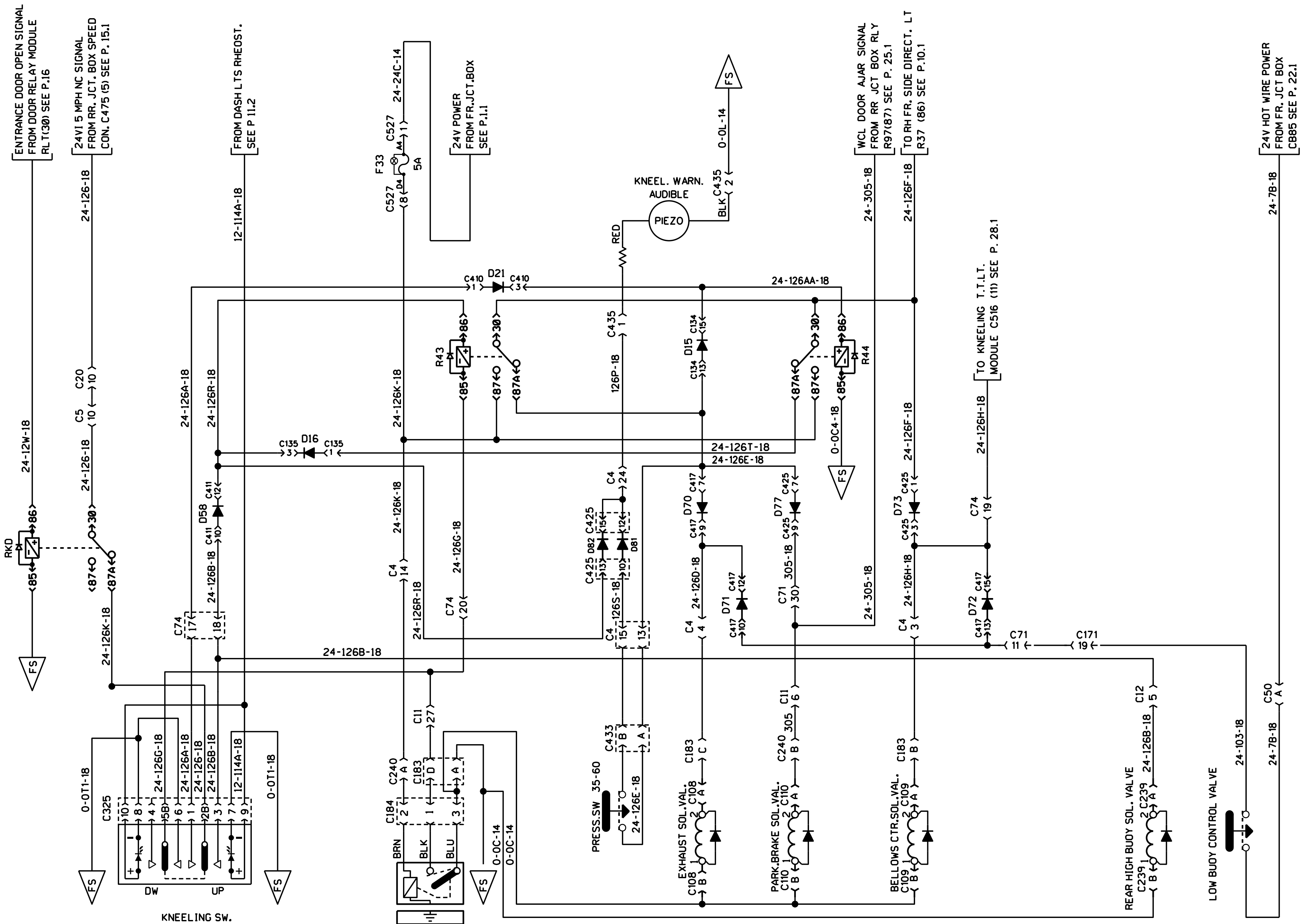

KNEELING OPERATE WHEN THE ENTRANCE DOOR IS CLOSE | HIBUOY | LOW BUOY

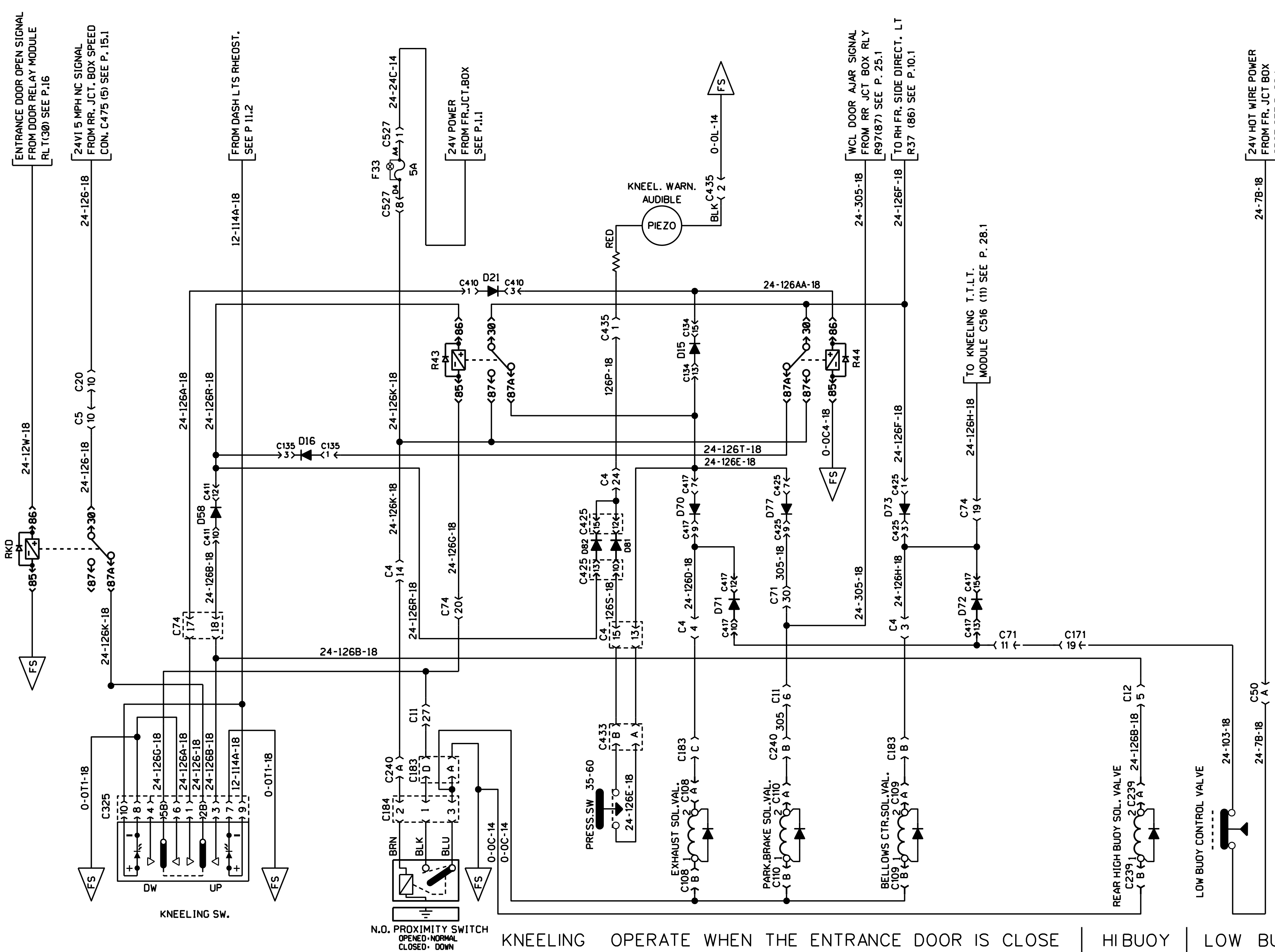

N.O. PROXIMITY SWITCH  
 OPENED-NORMAL  
 CLOSED-DOWN

KNEELING OPERATE WHEN THE ENTRANCE DOOR IS CLOSE | HIBUOY | LOW BUOY



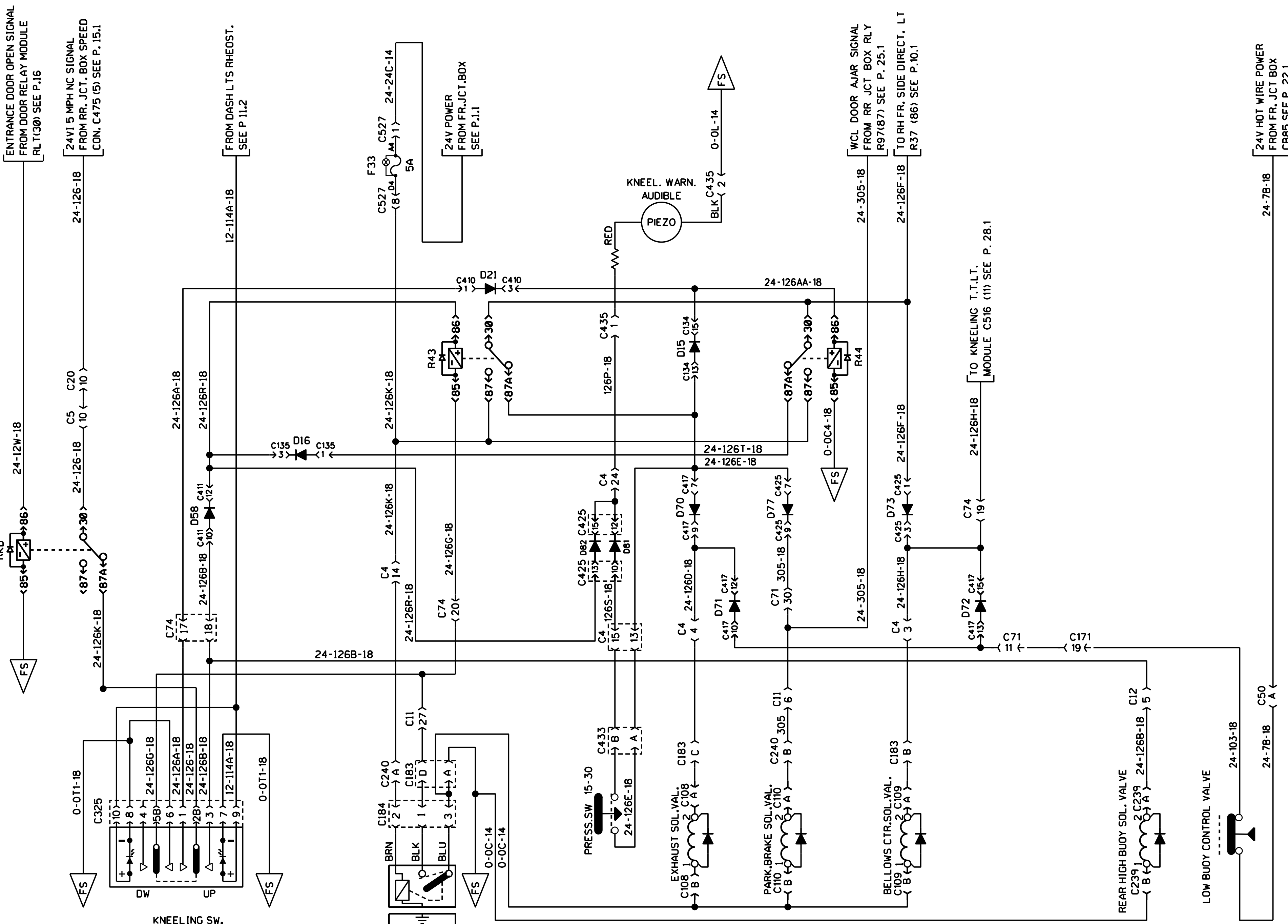

N.O. PROXIMITY SWITCH  
 OPENED-NORMAL  
 CLOSED-DOWN

KNEELING OPERATE WHEN THE ENTRANCE DOOR IS CLOSE | HIBUOY | LOW BUOY

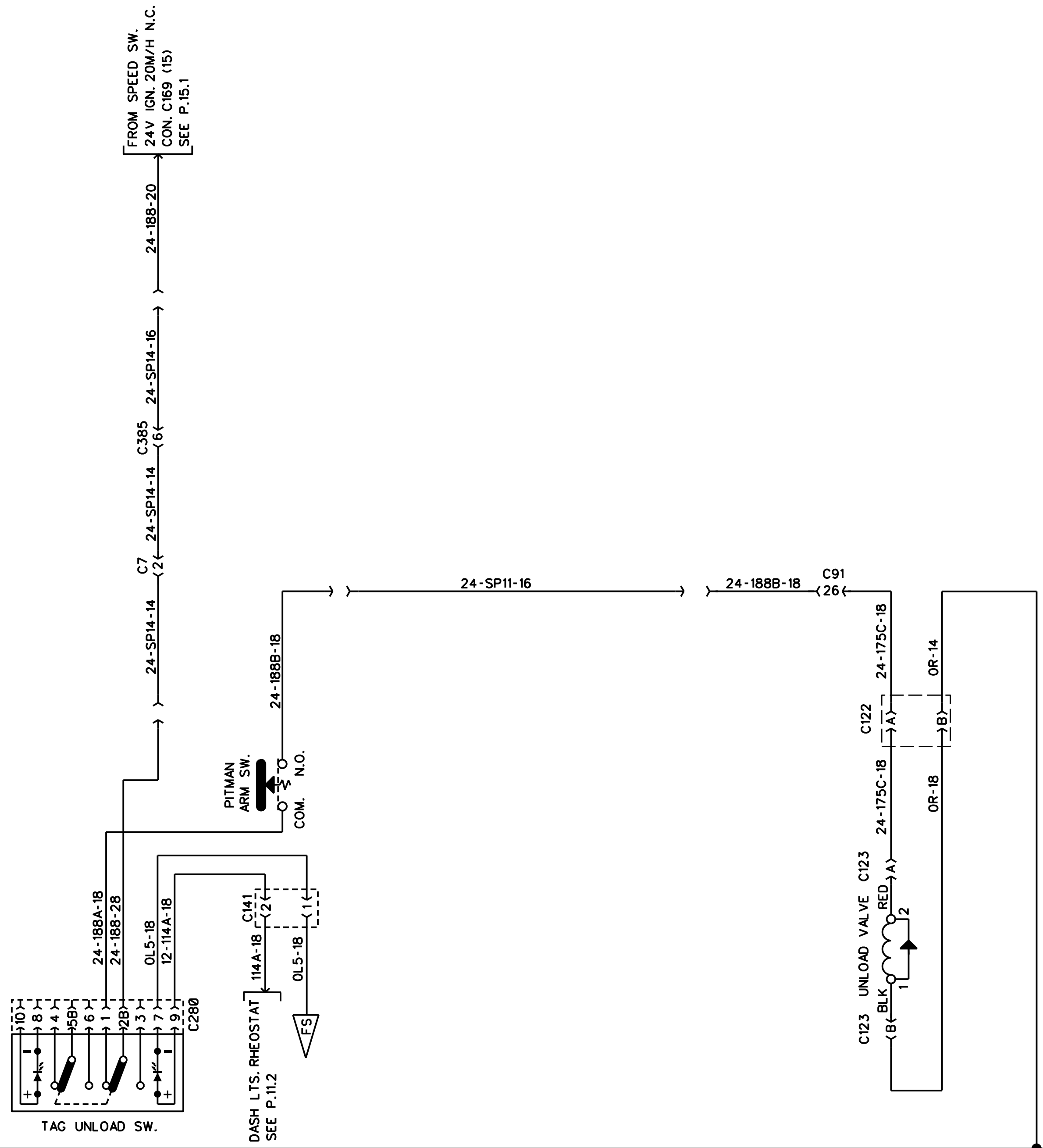

UNLOAD TAG SYSTEM

CHASSIS GROUND

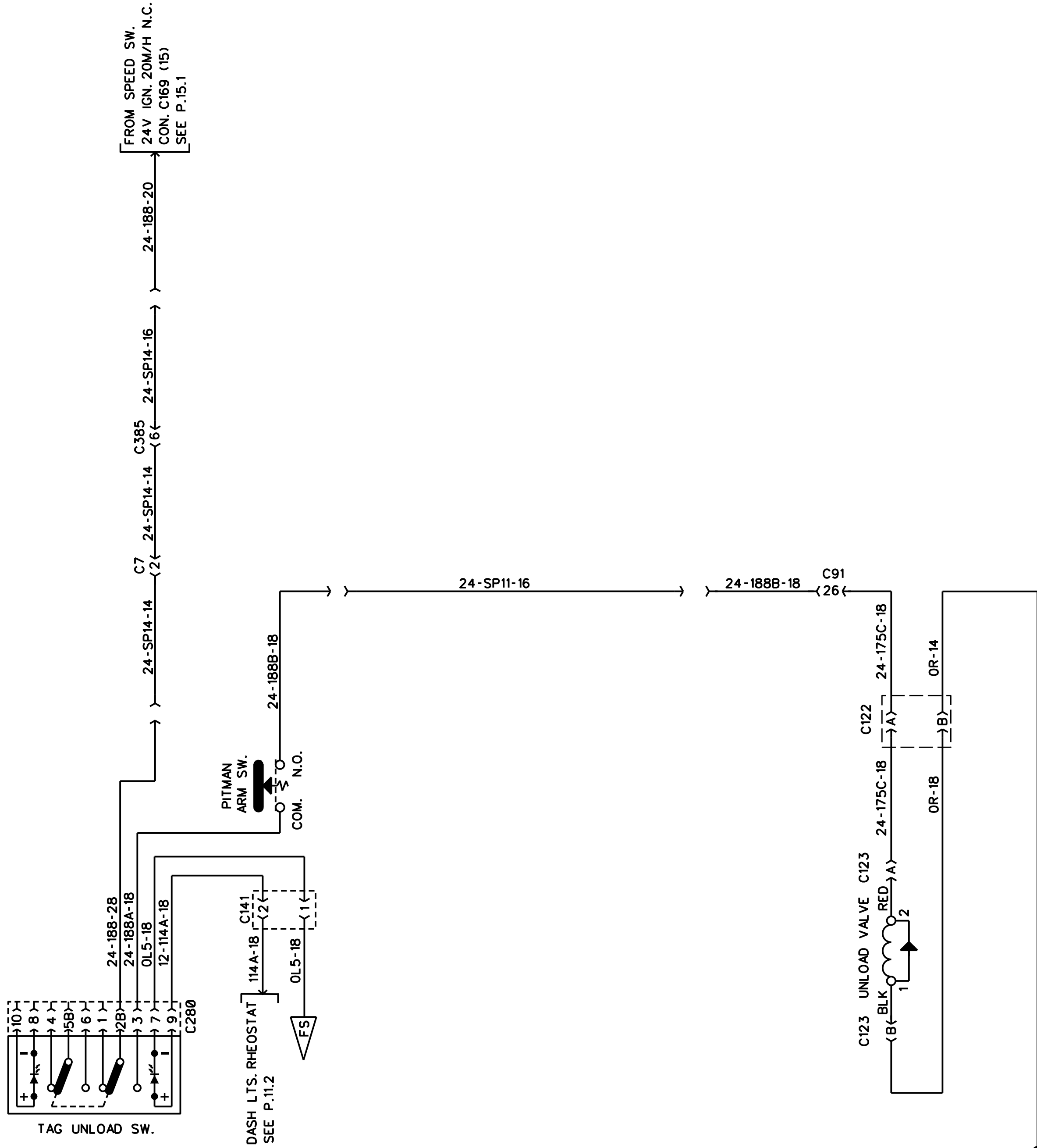

### UNLOAD TAG SYSTEM

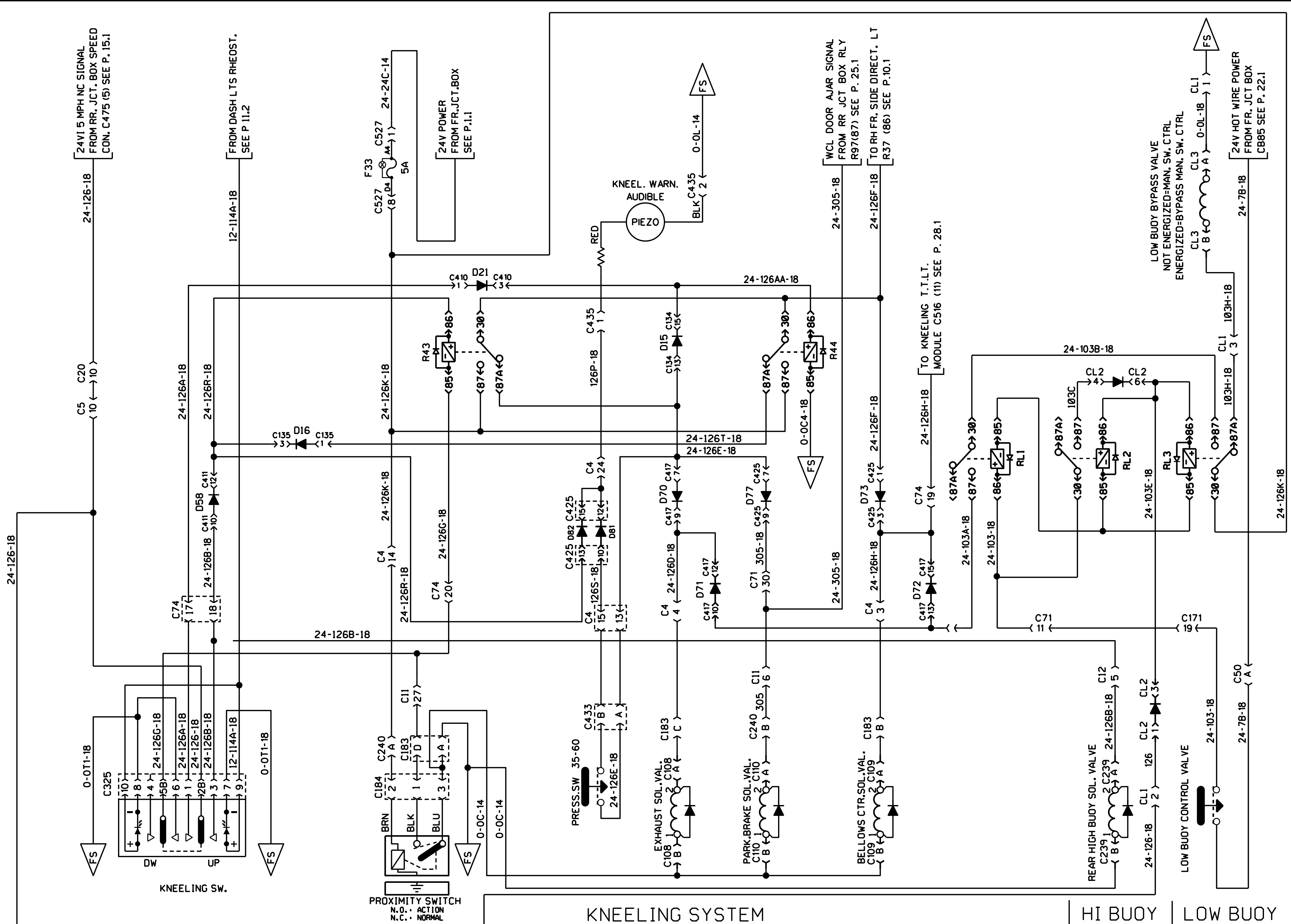

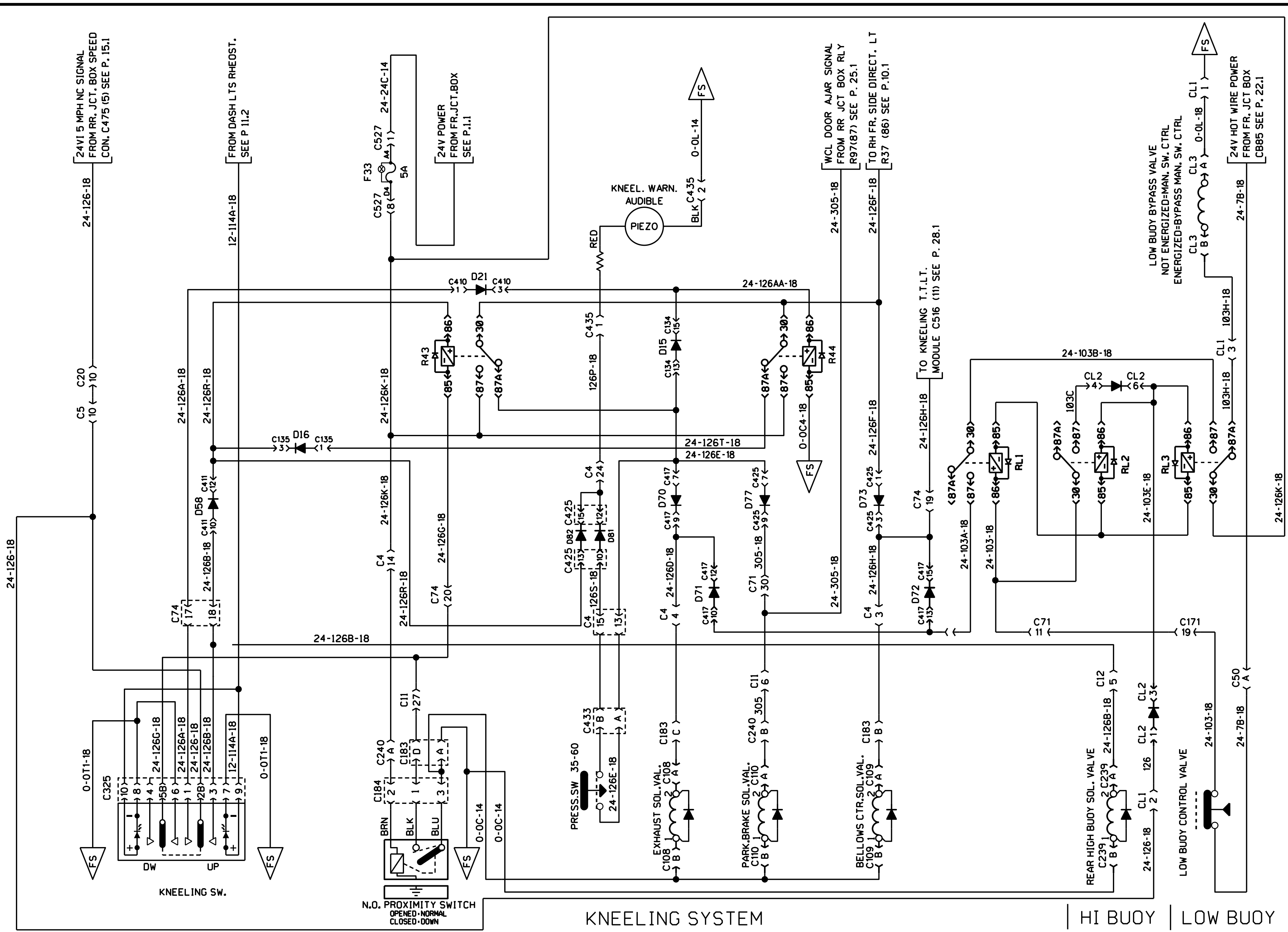

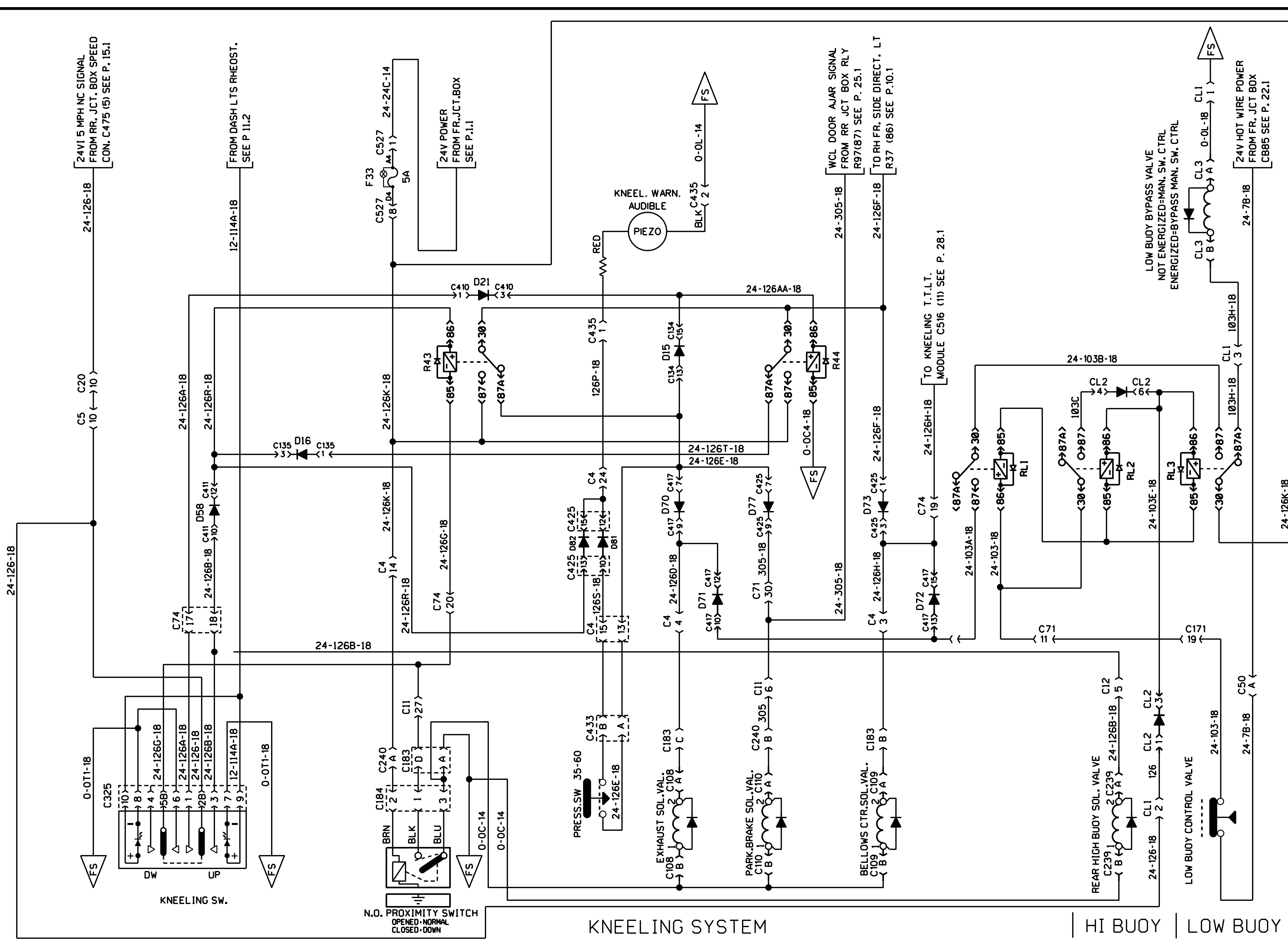

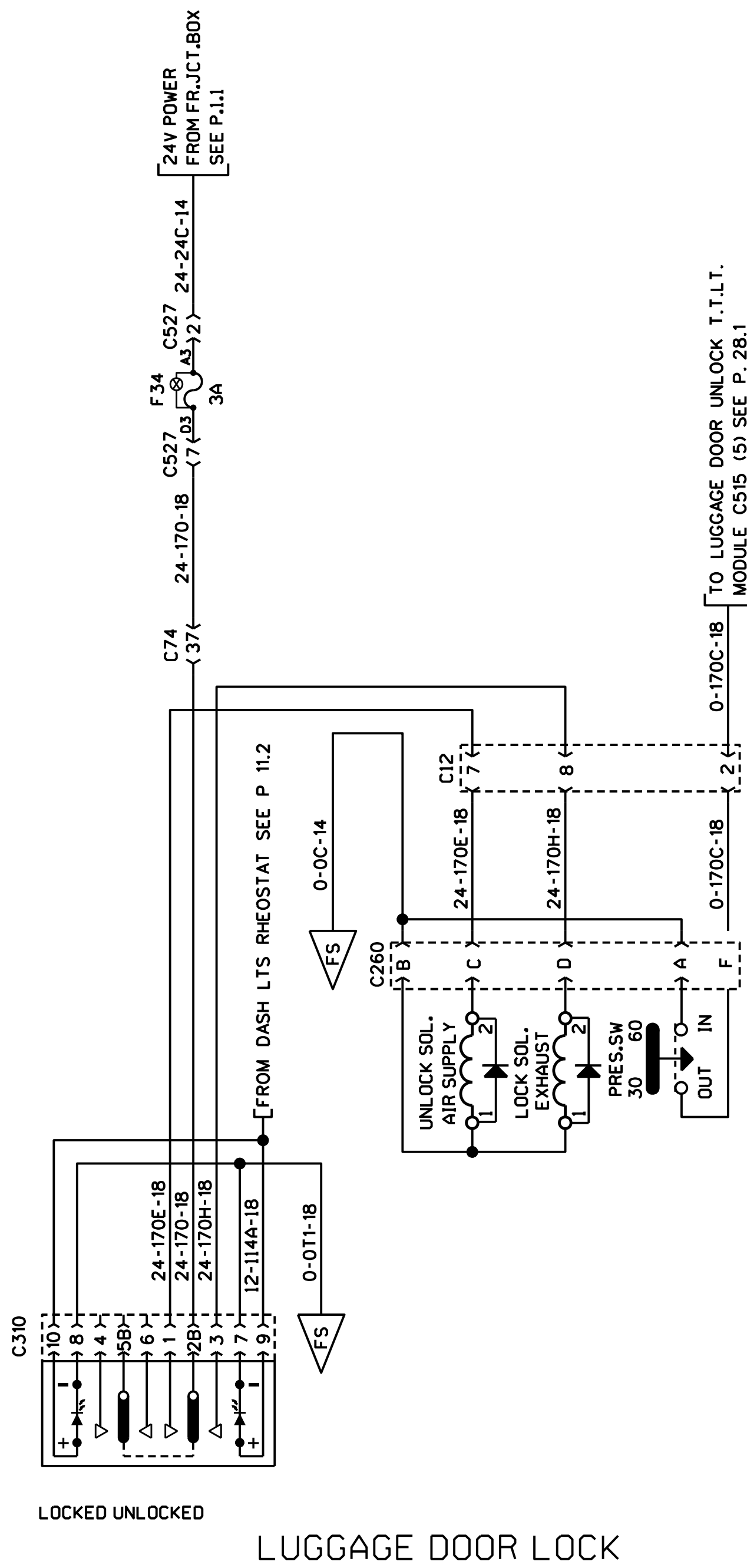

LUGGAGE DOOR LOCK

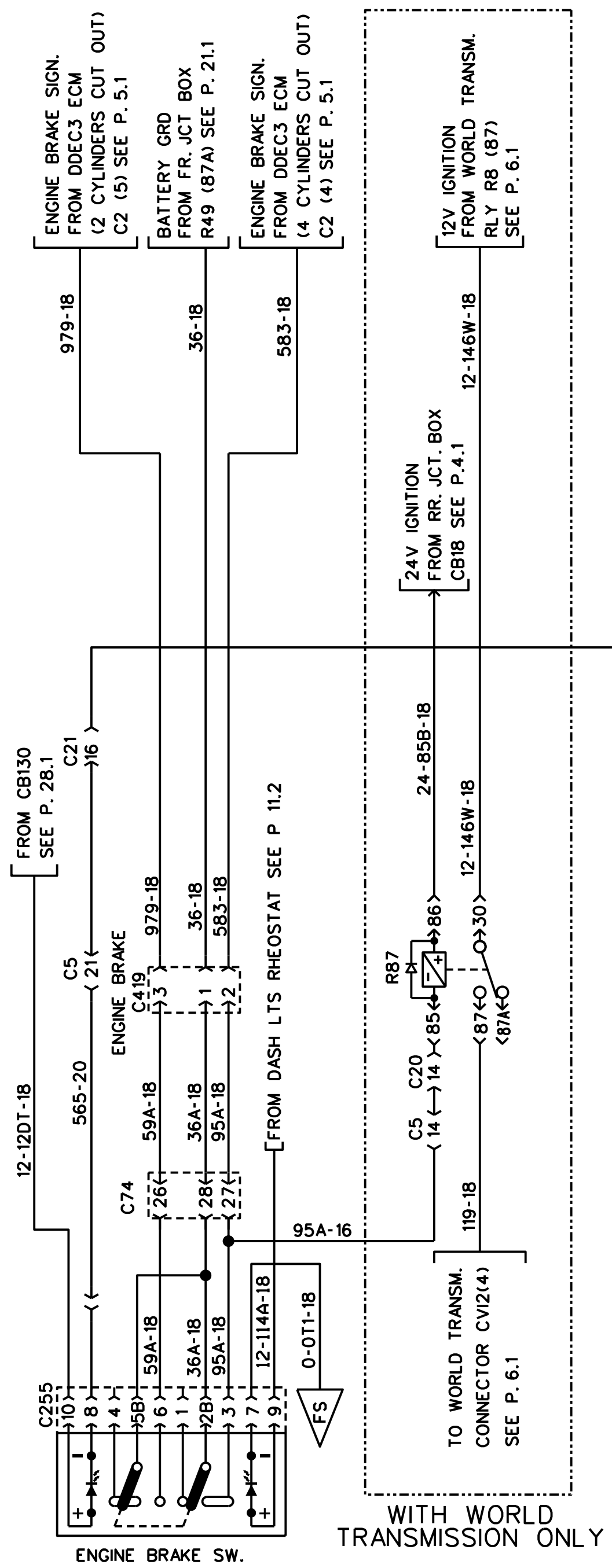

ENGINE BRAKE SYSTEM

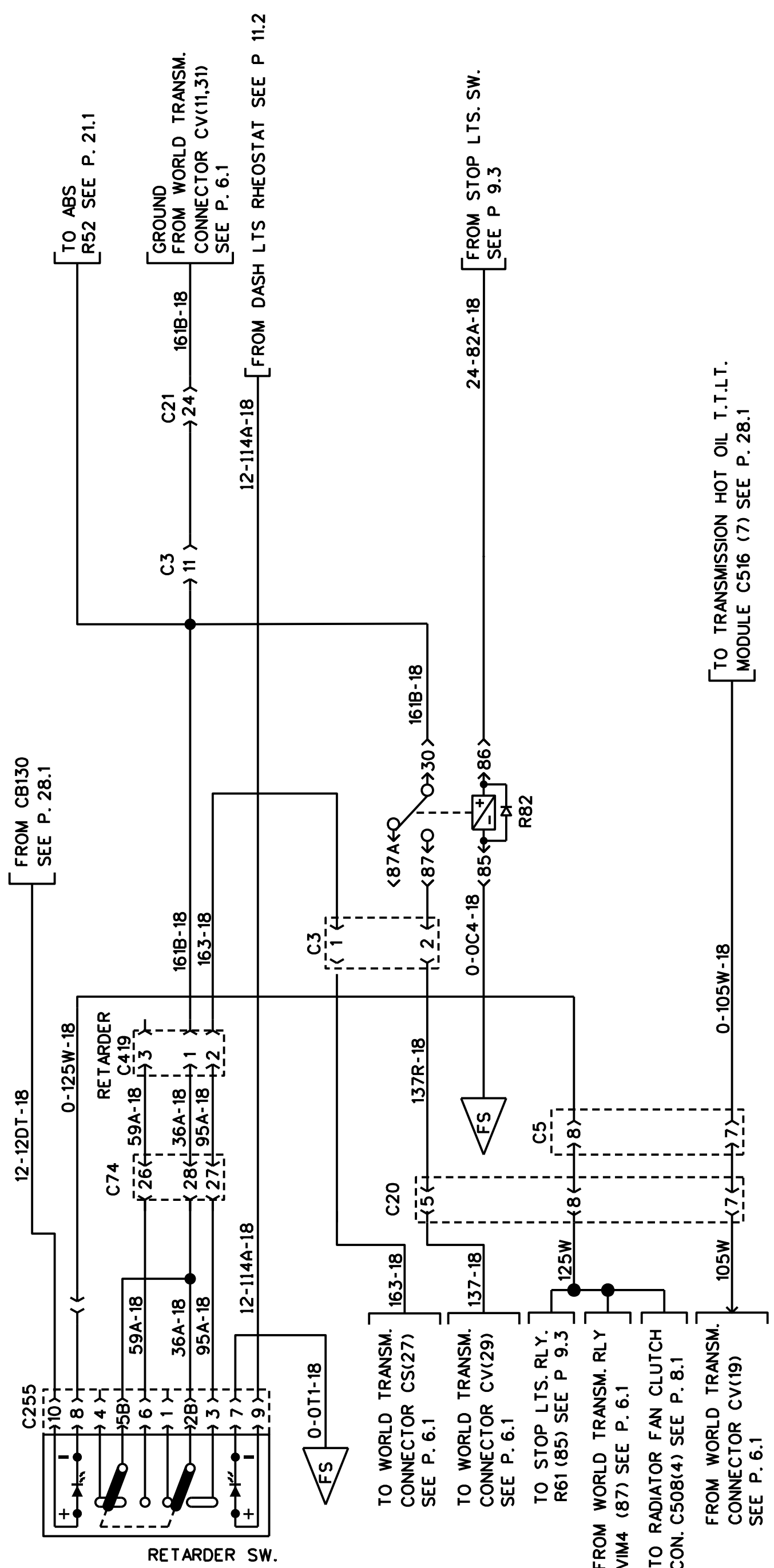

RETARDER SYSTEM (WORLD TRANSMISSION)



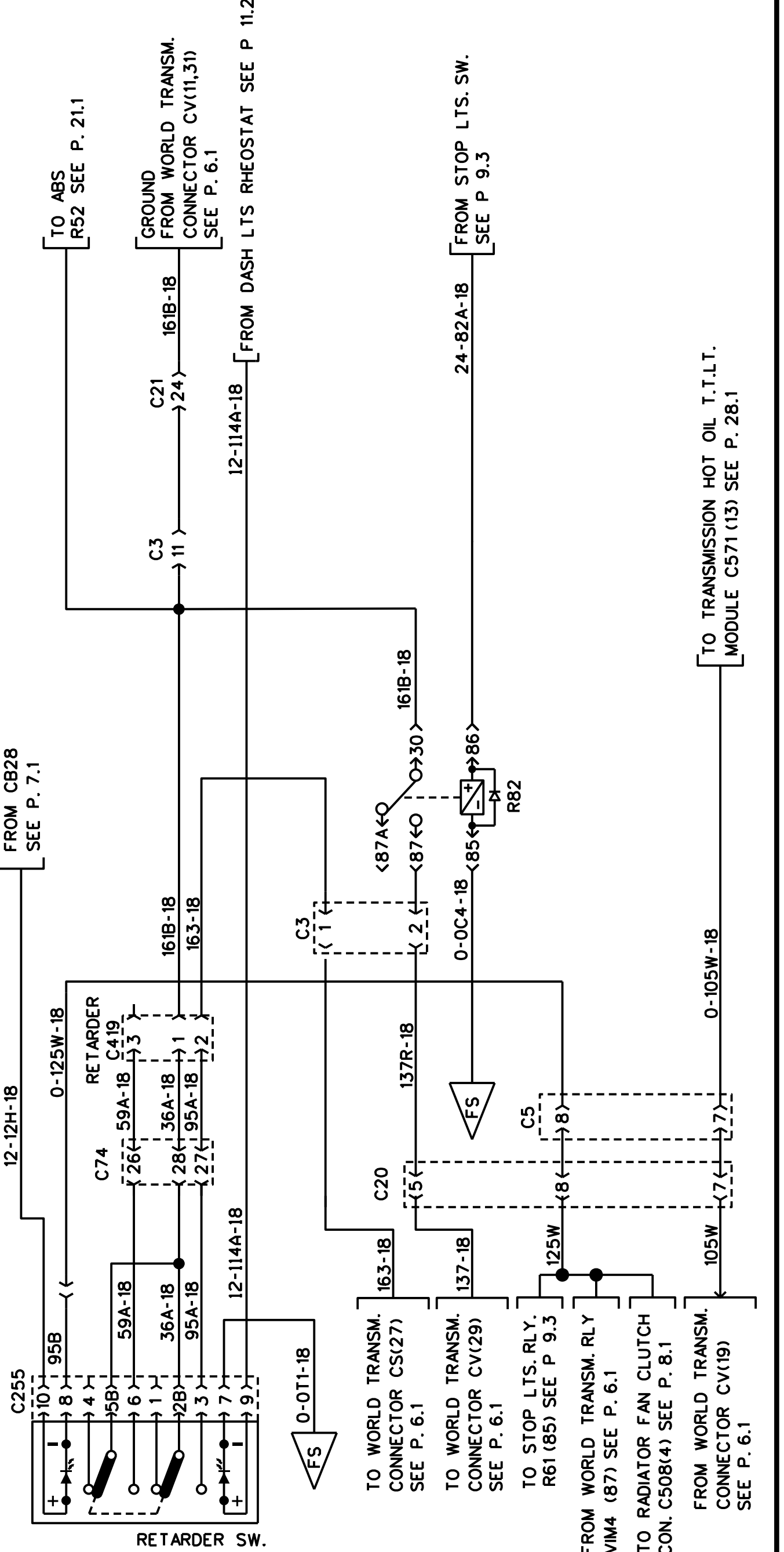
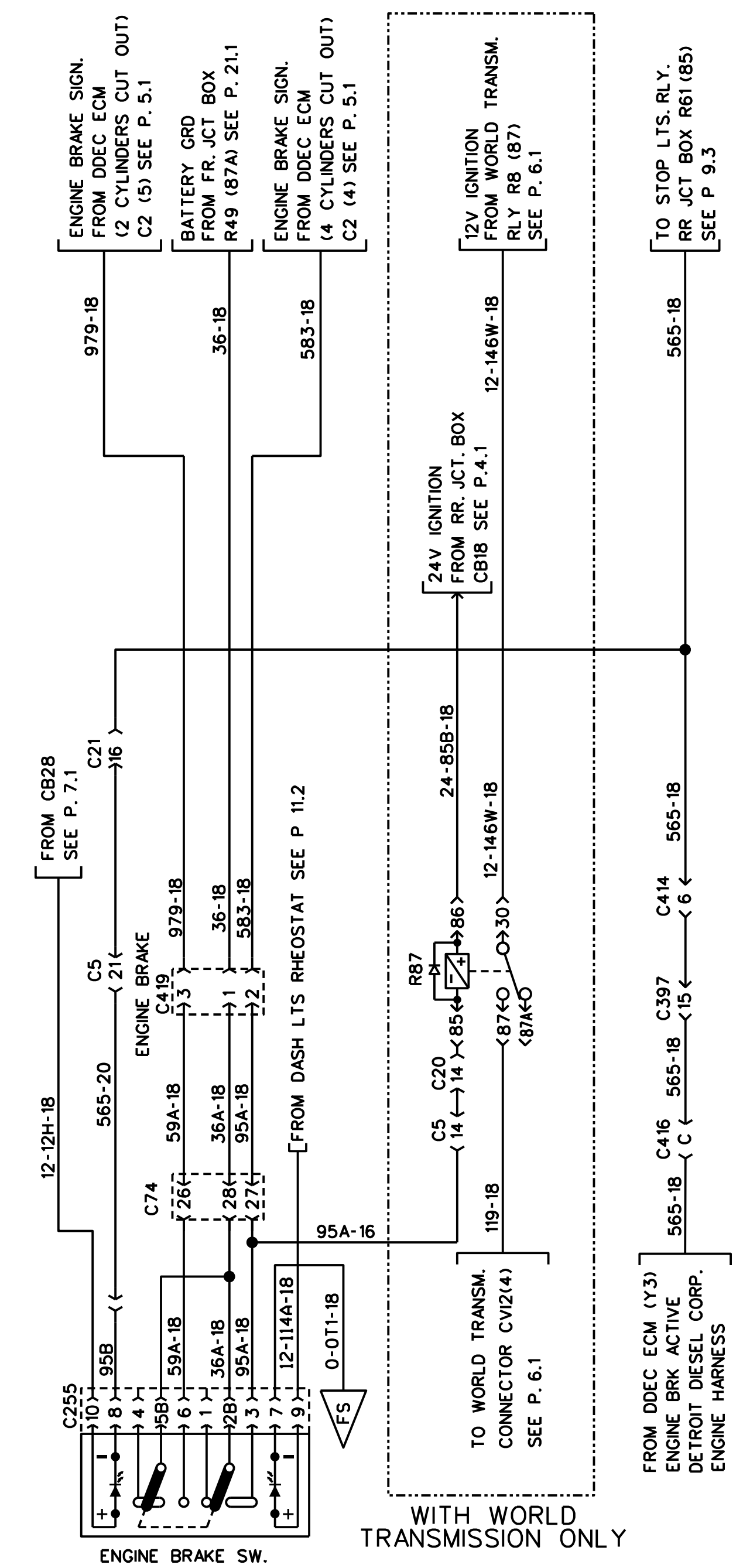
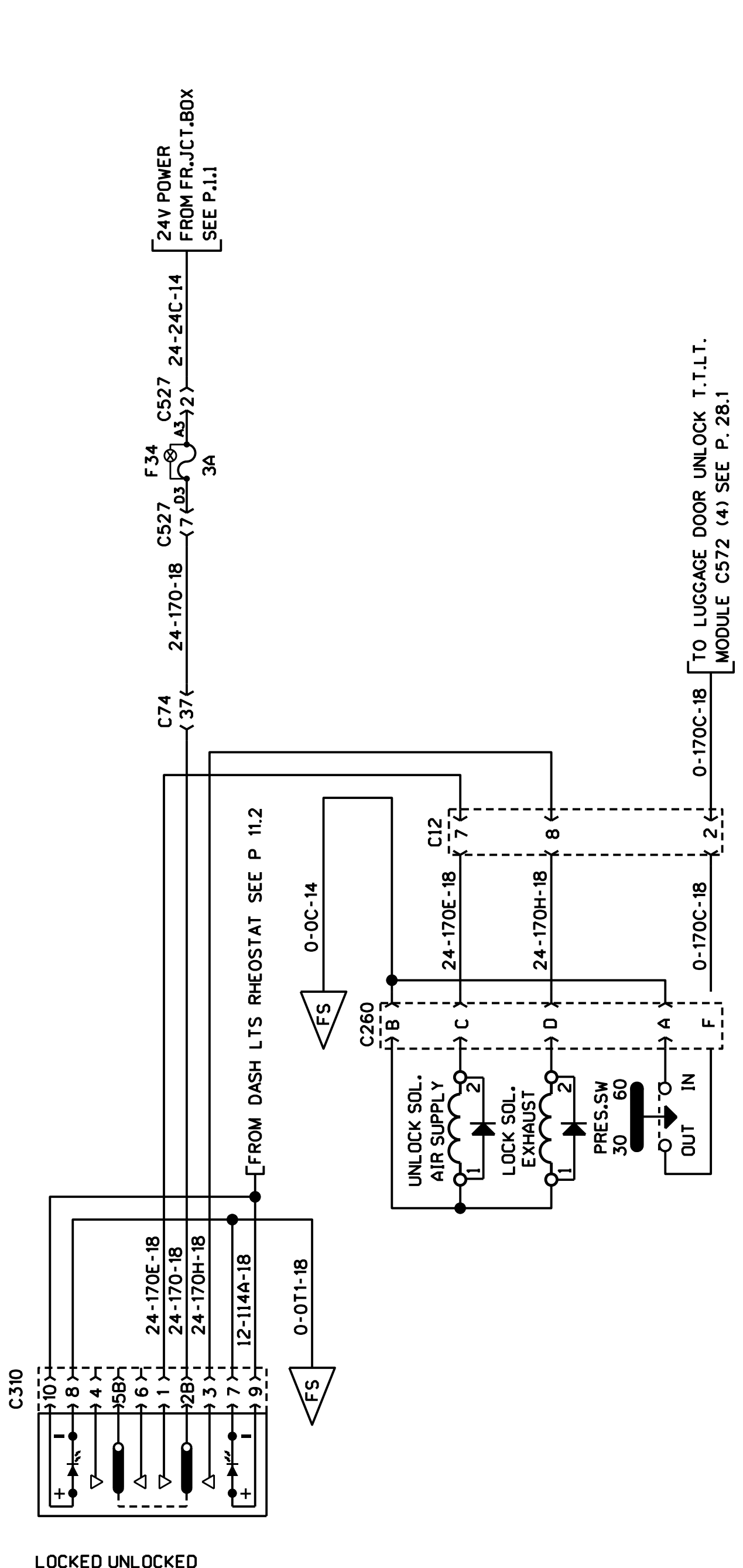

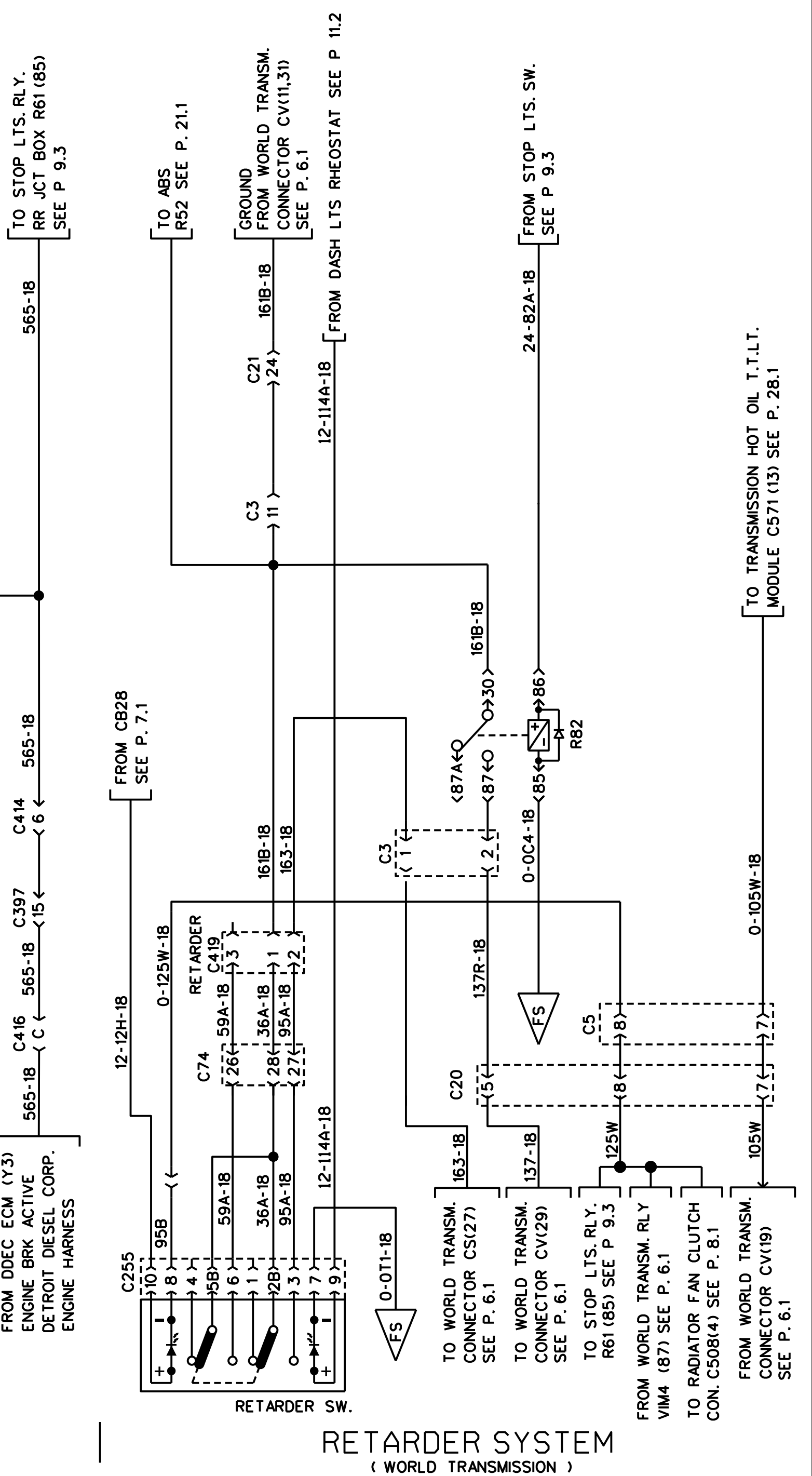
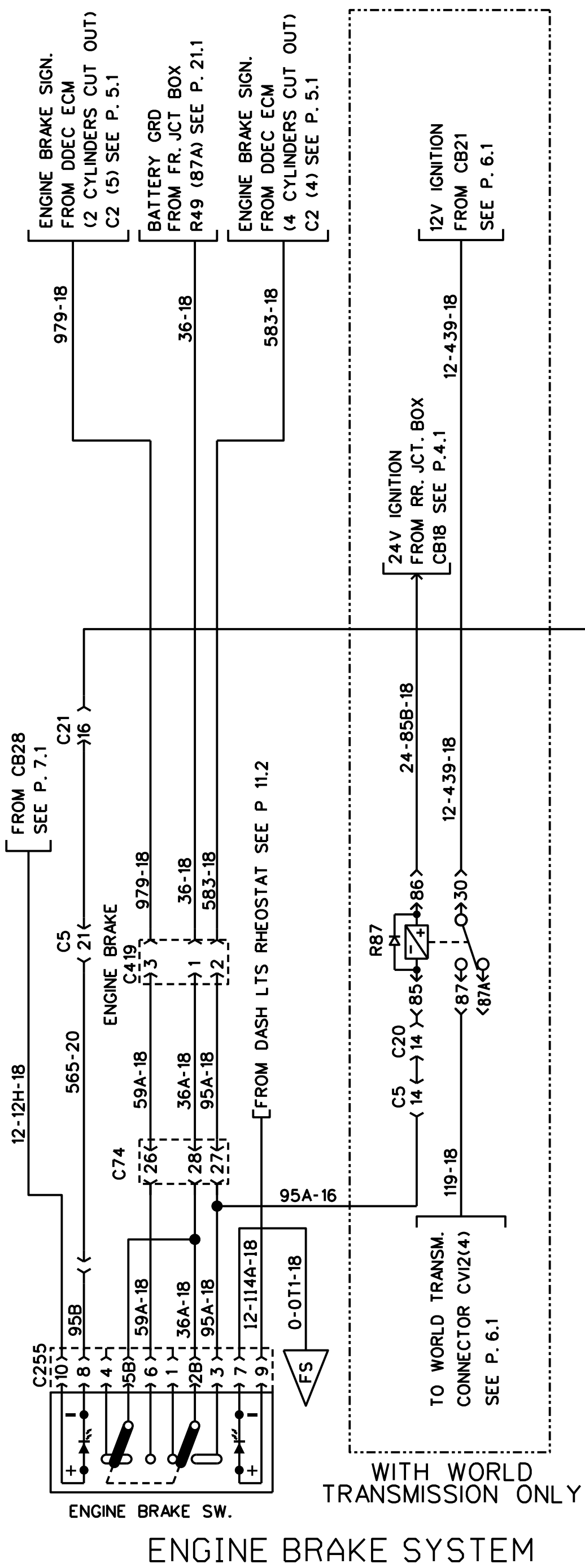
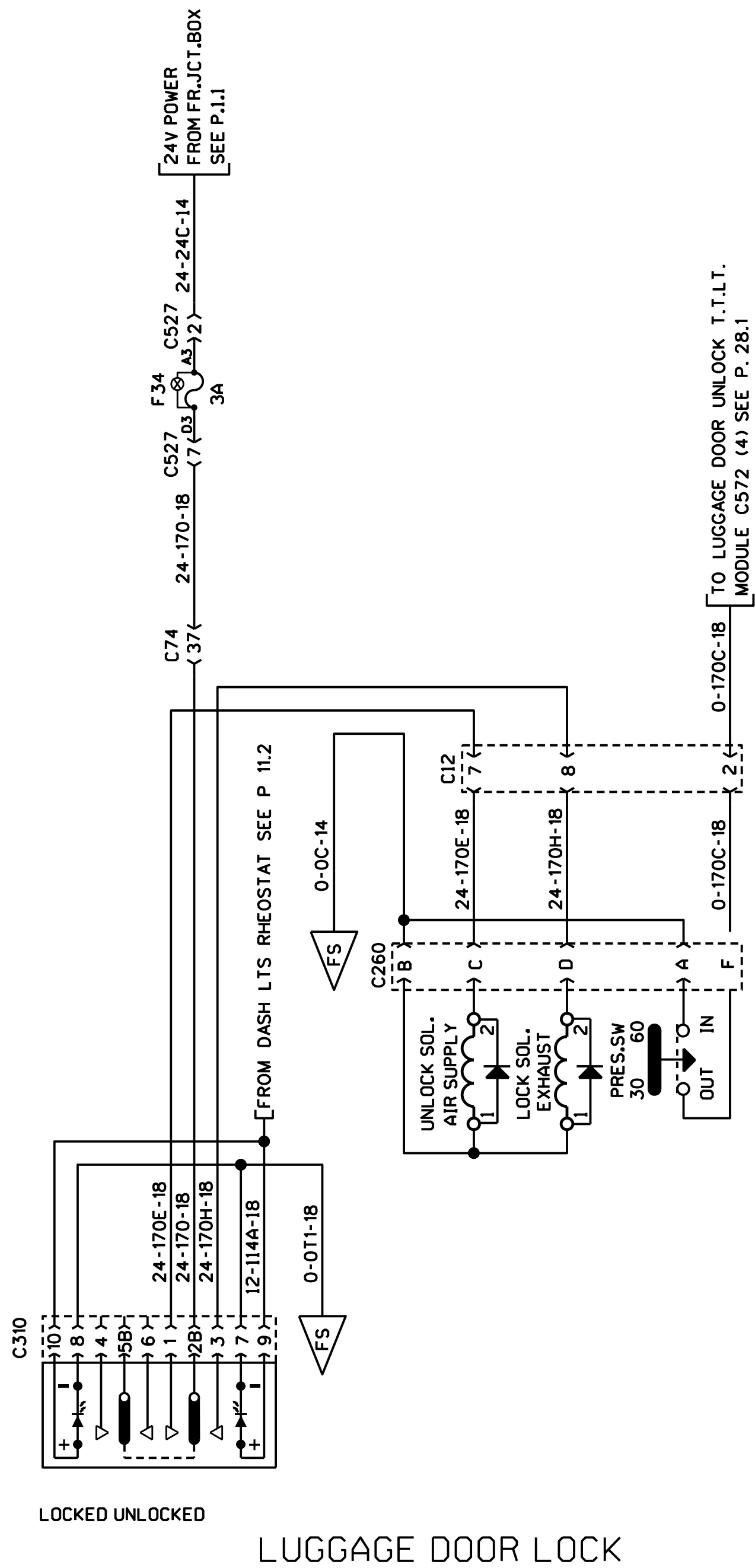

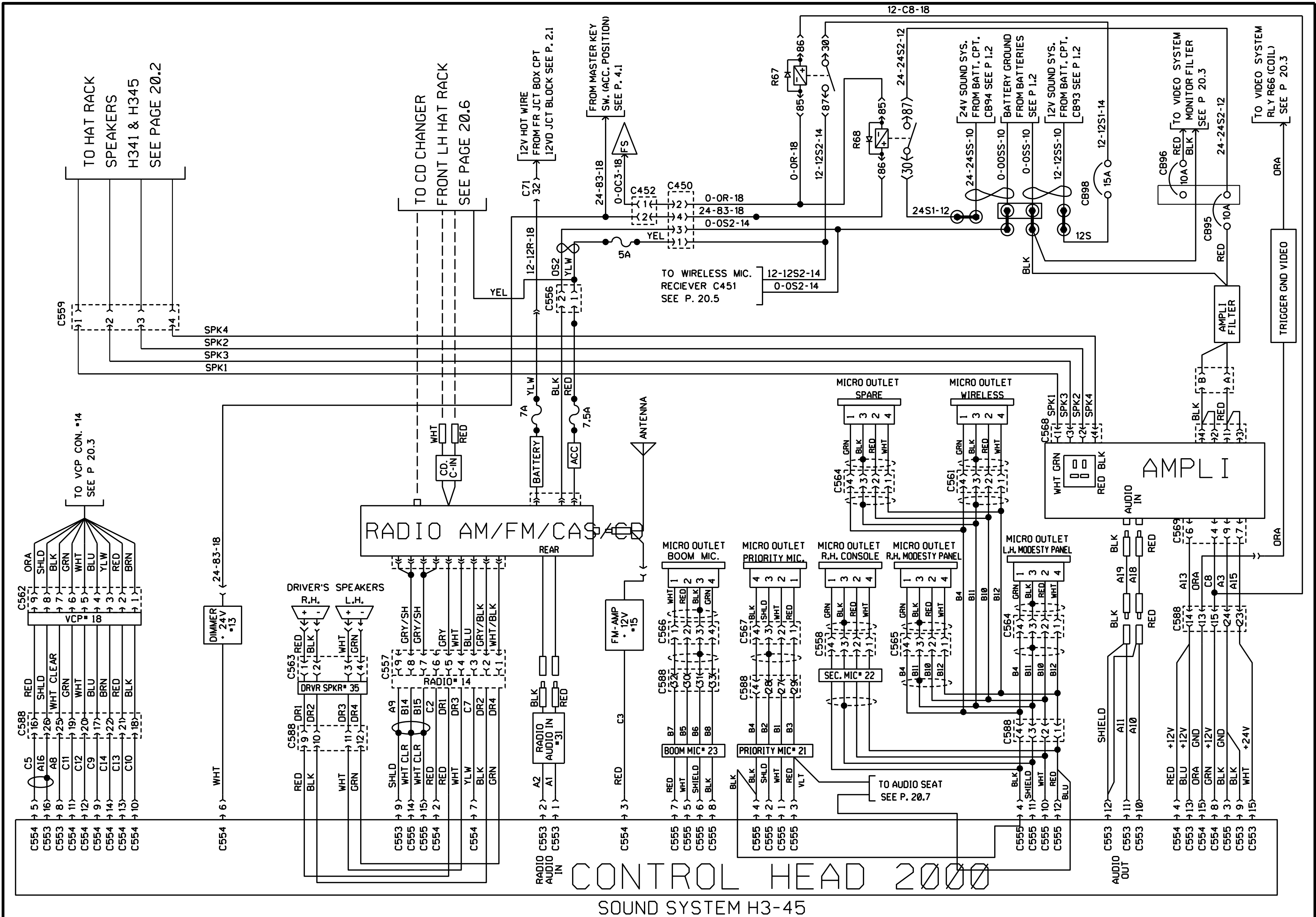

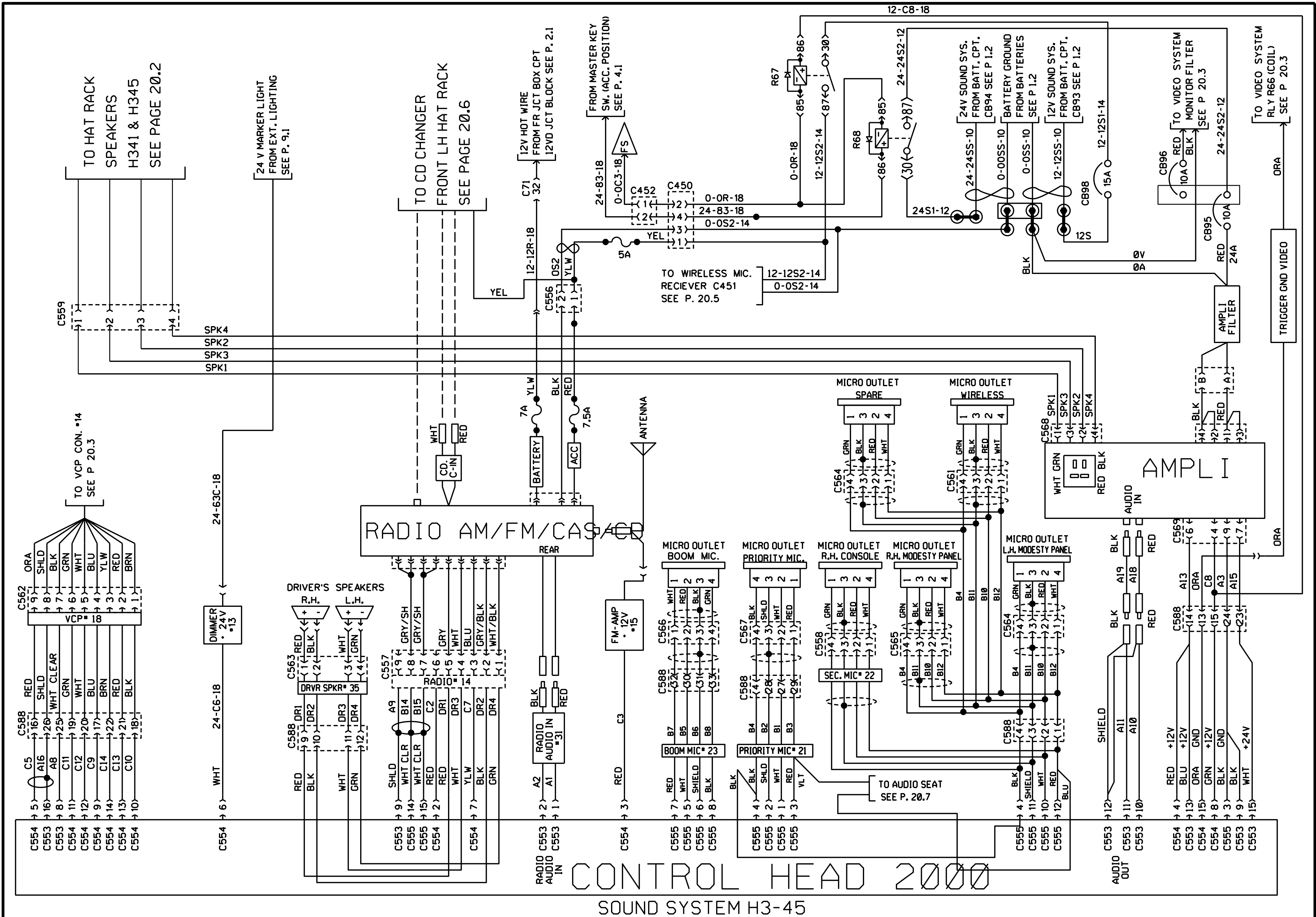

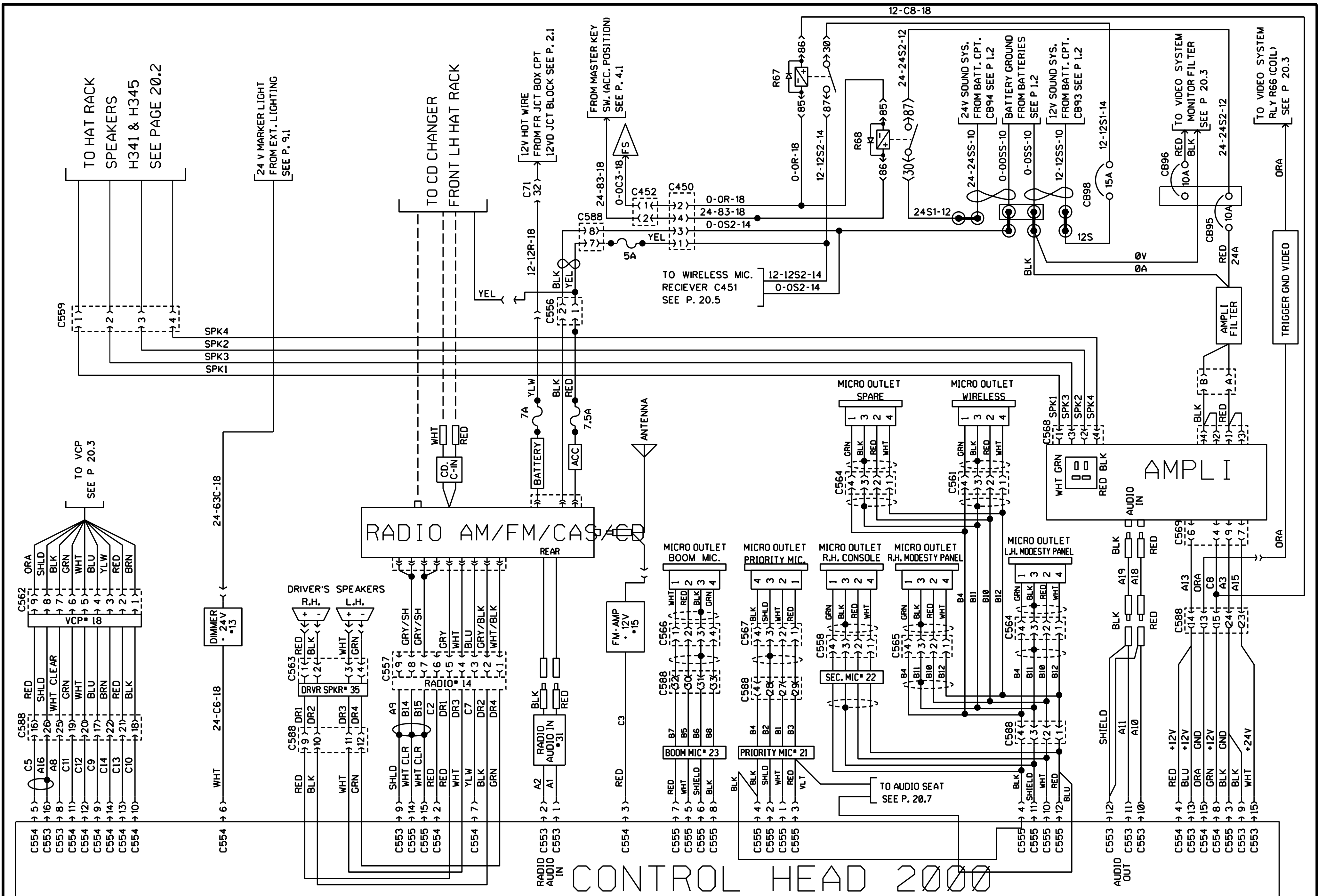

CONTROL HEAD 2000  
SOUND SYSTEM H3-45

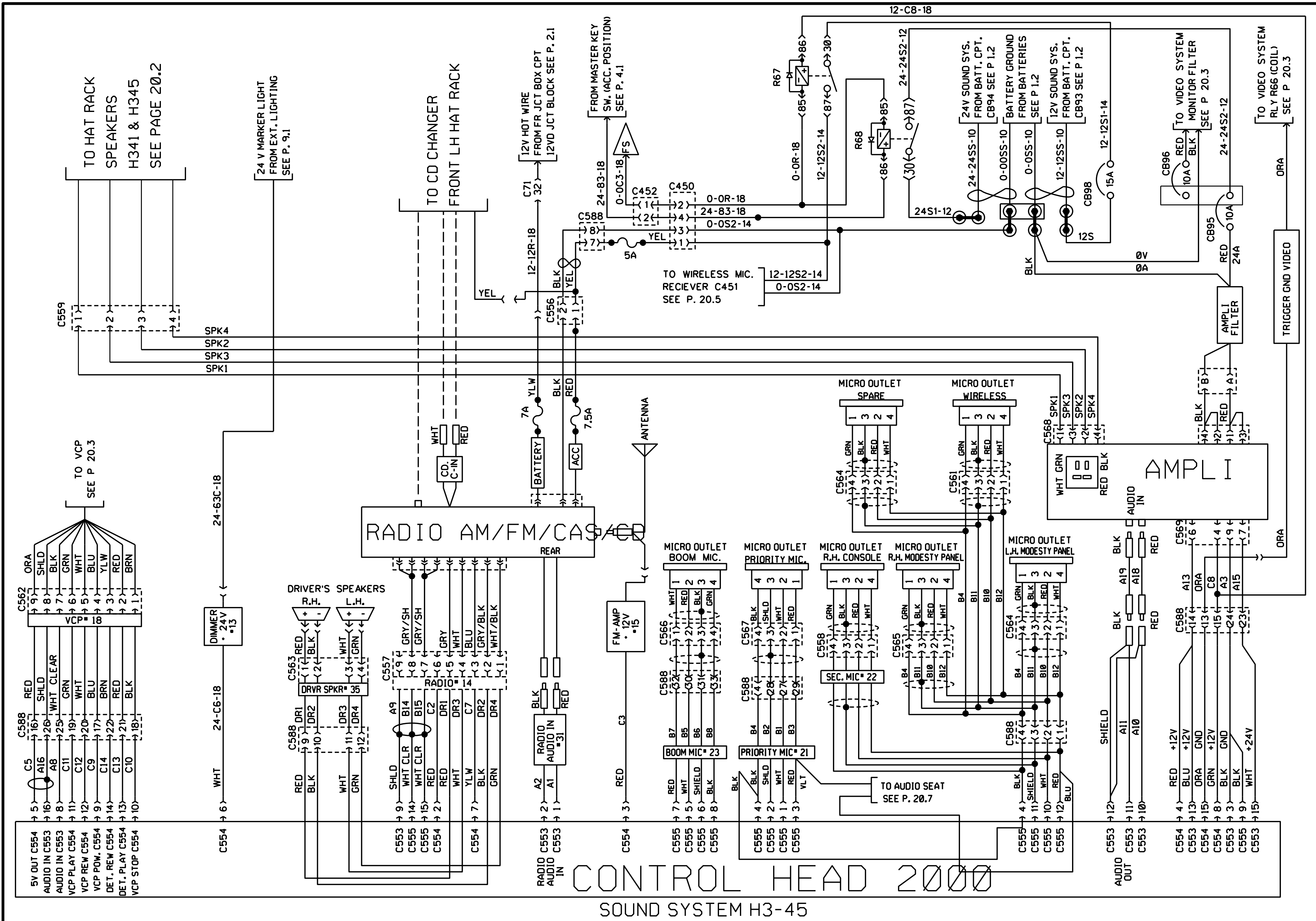

CONTROL HEAD 2000  
SOUND SYSTEM H3-45

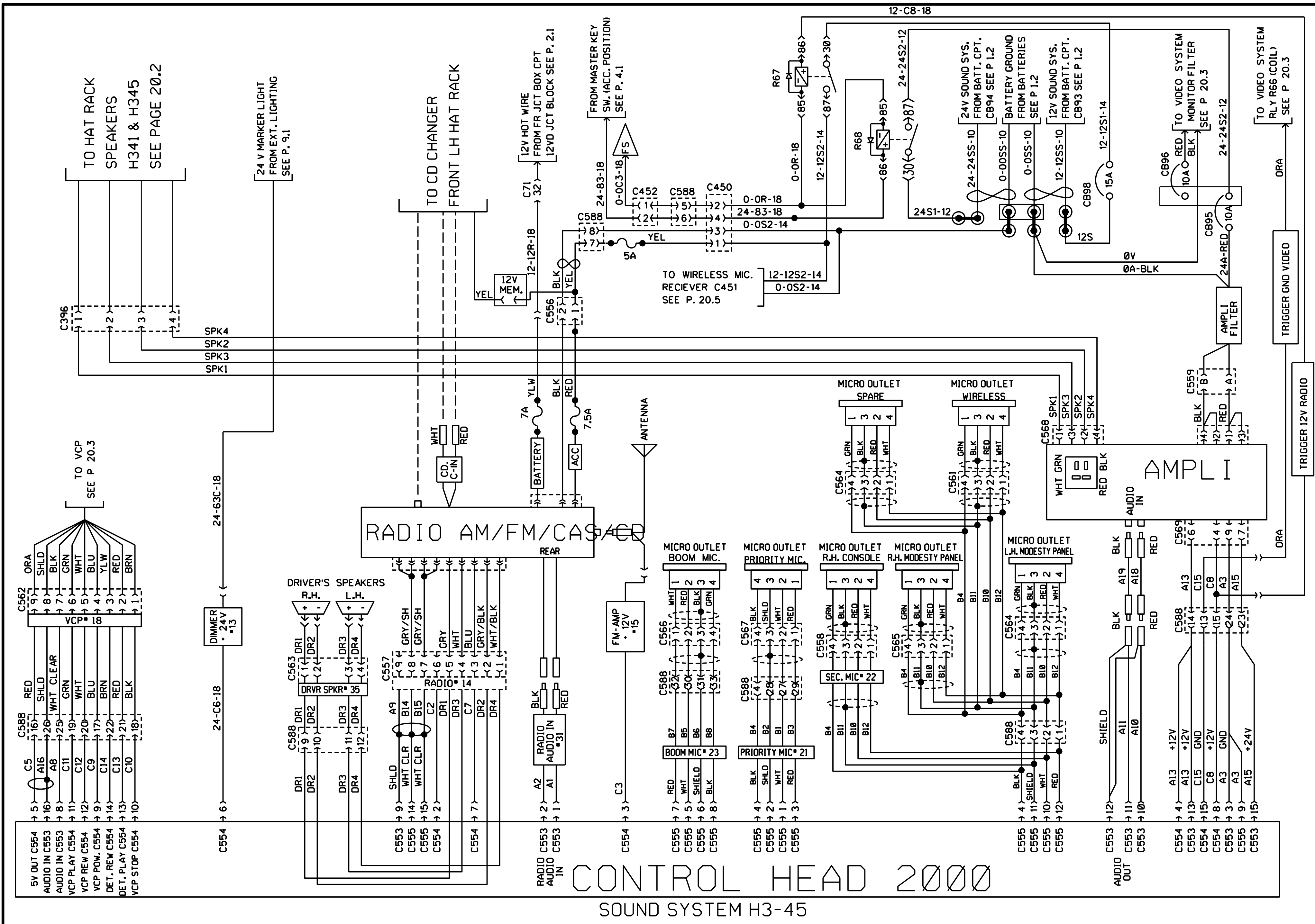



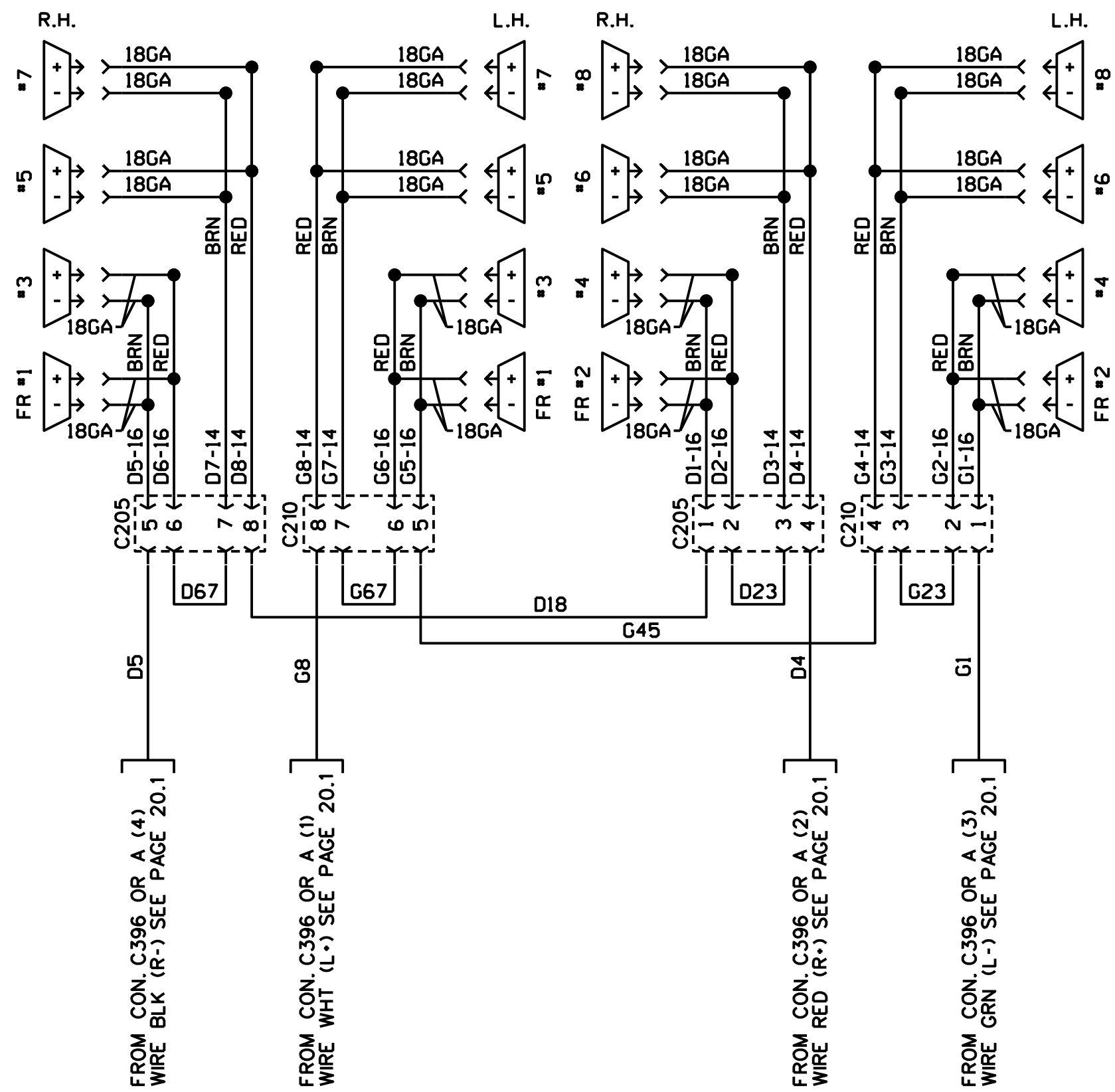

HAT RACK SPEAKERS H3-45

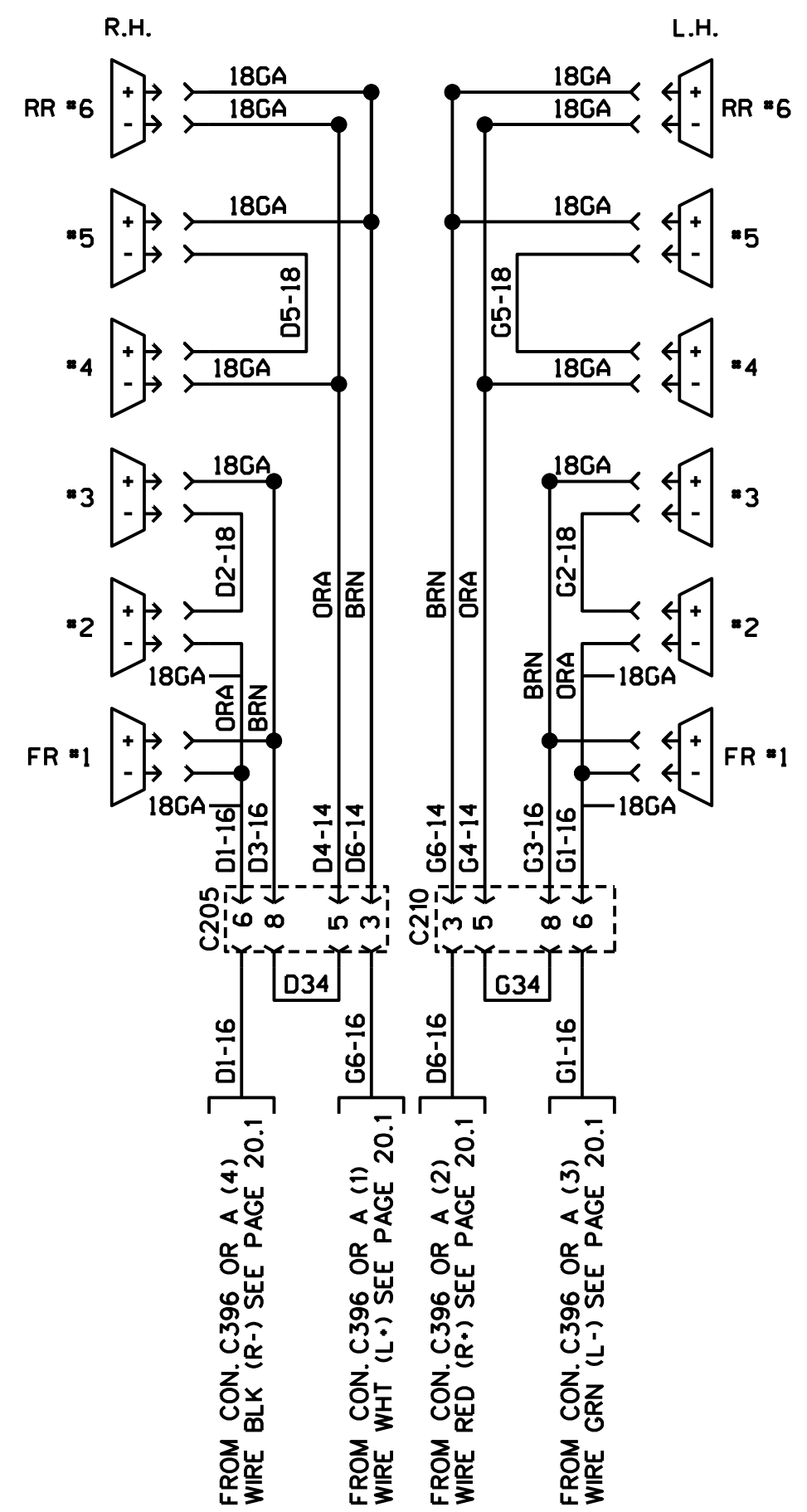

HAT RACK SPEAKERS H3-41

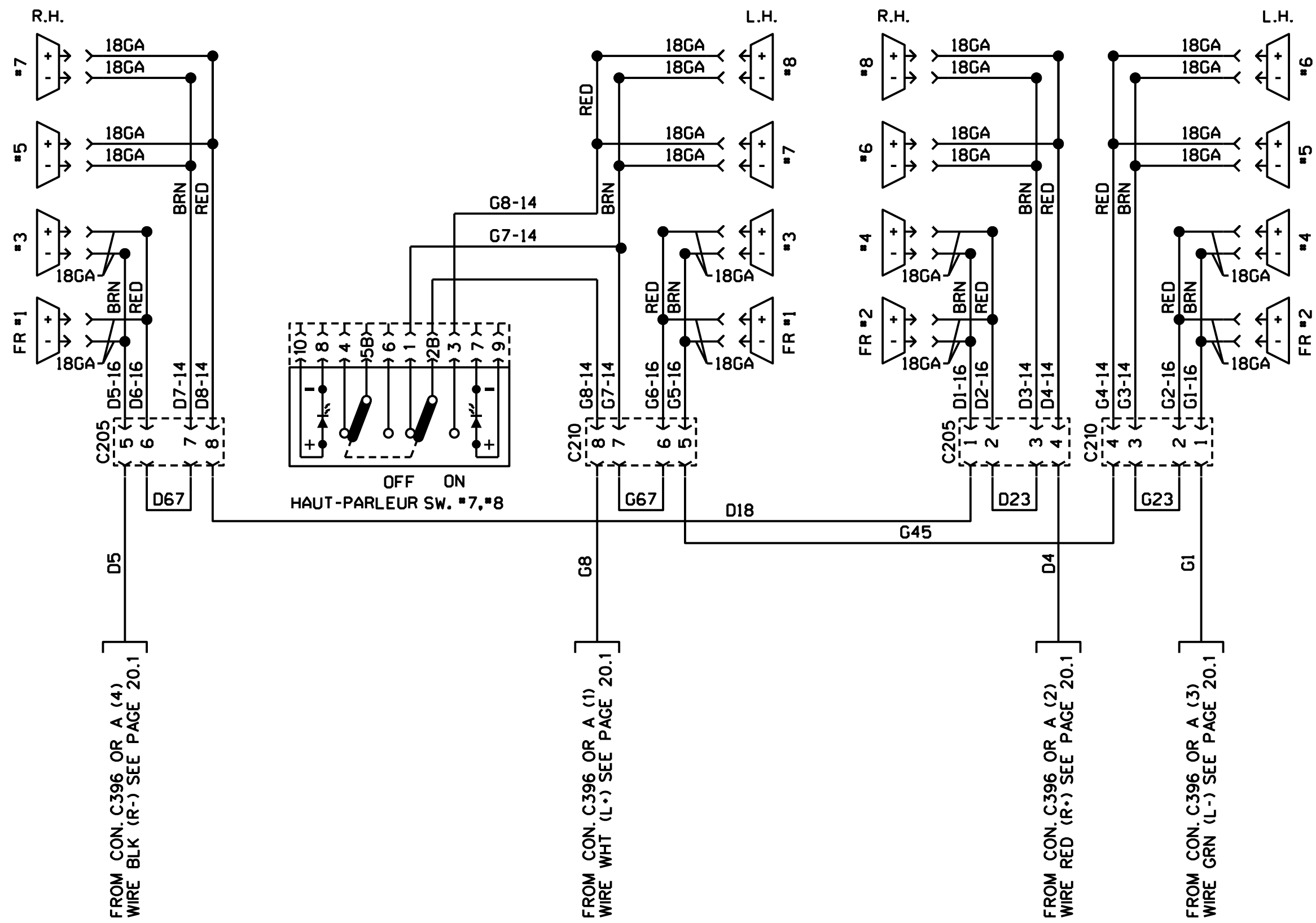

# HAT RACK SPEAKERS H3-45

X3298 (LIMOCAR)

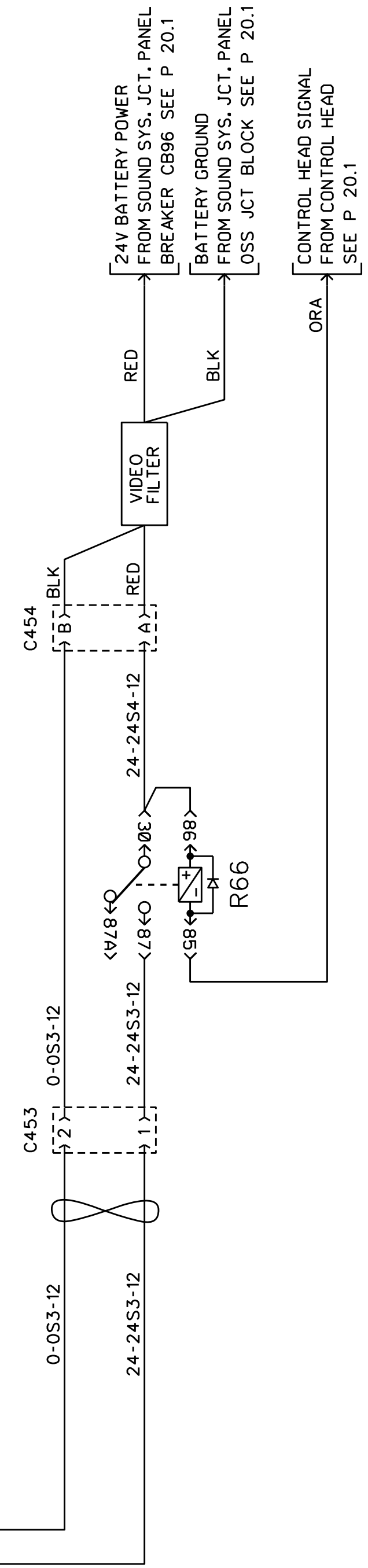
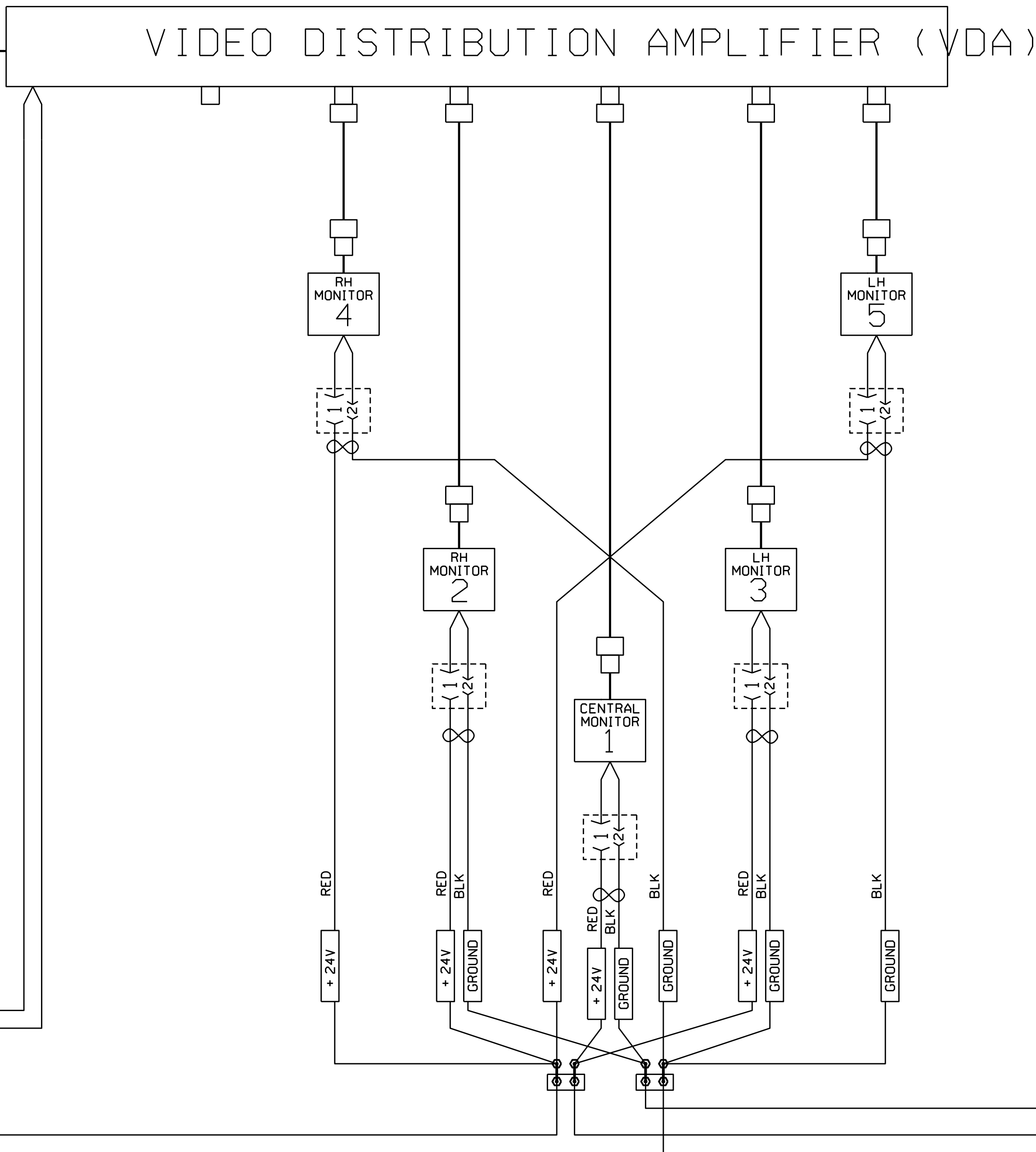
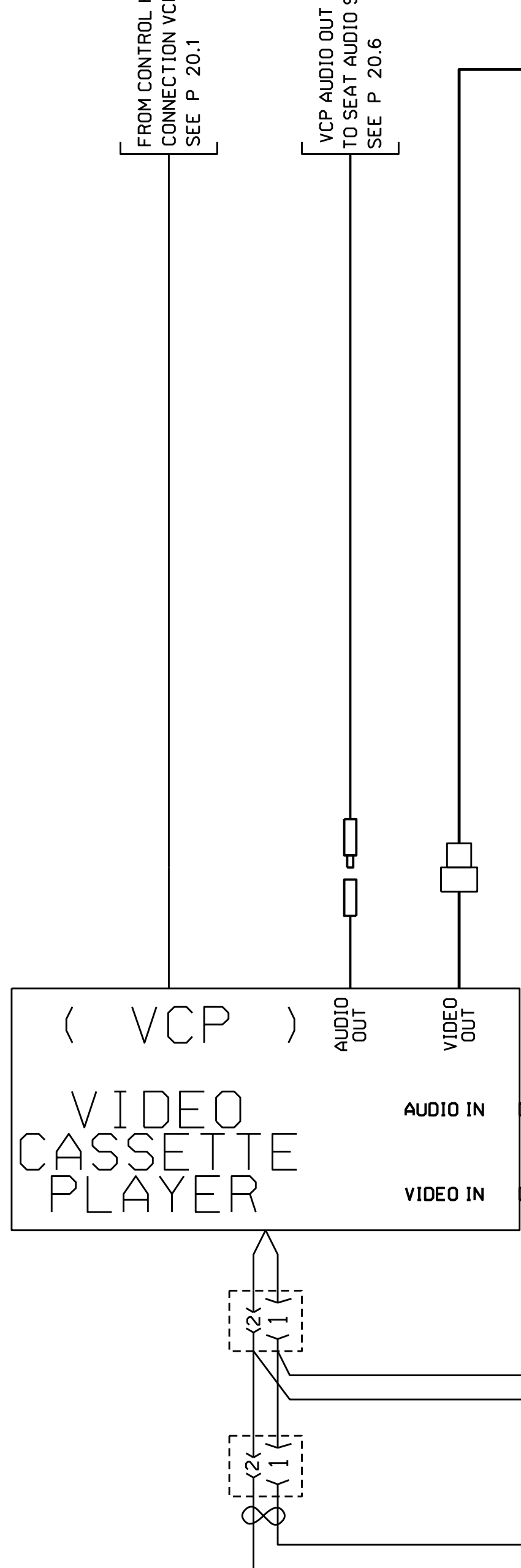

VIDEO SYSTEM



# VIDEO DISTRIBUTION AMPLIFIER (VDA)

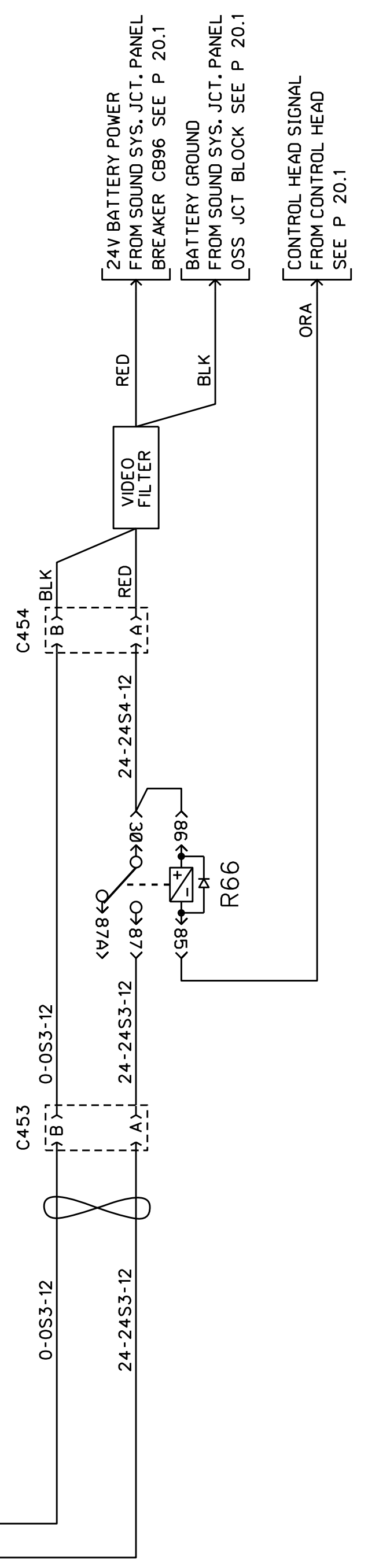
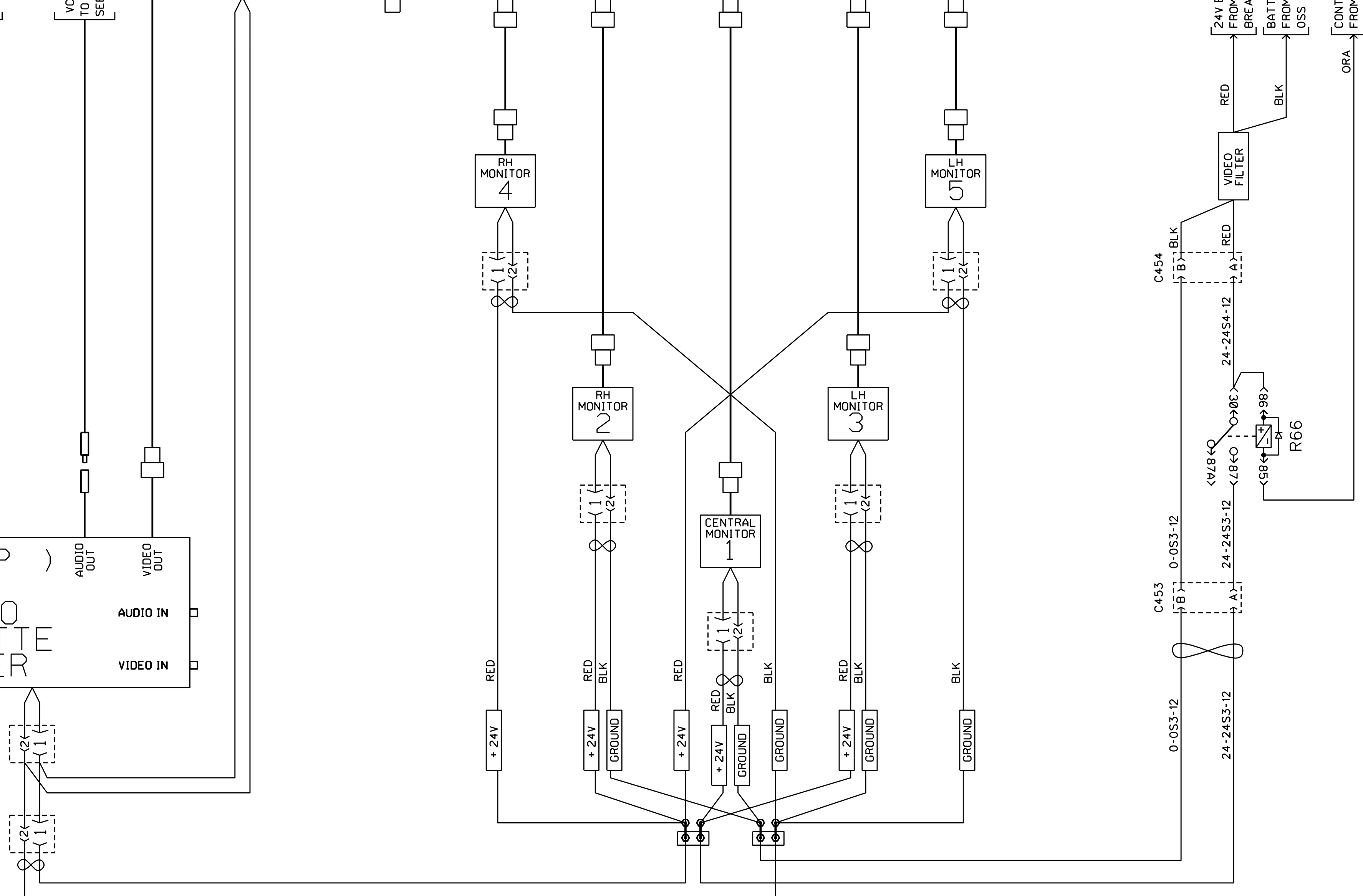

VIDEO SYSTEM



# VIDEO DISTRIBUTION AMPLIFIER (VDA)

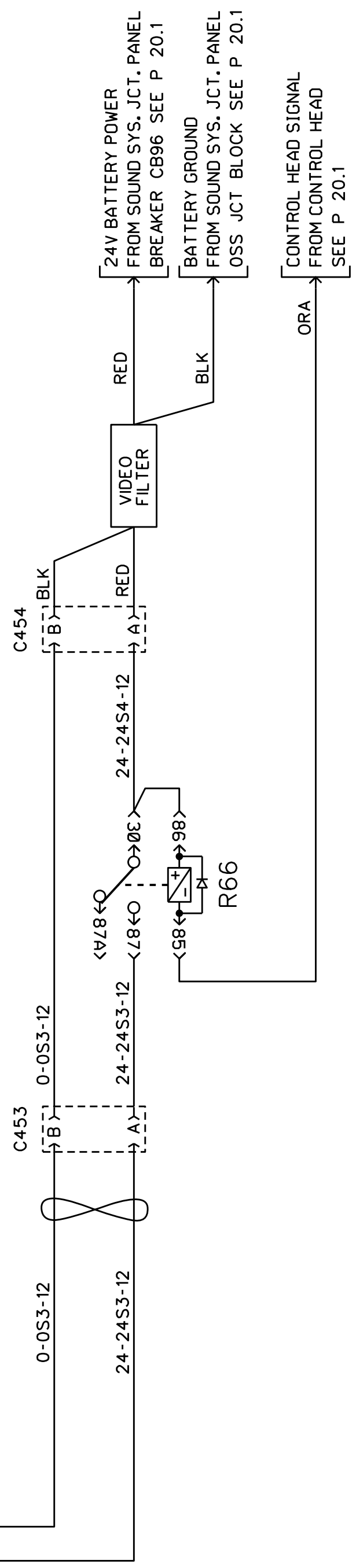
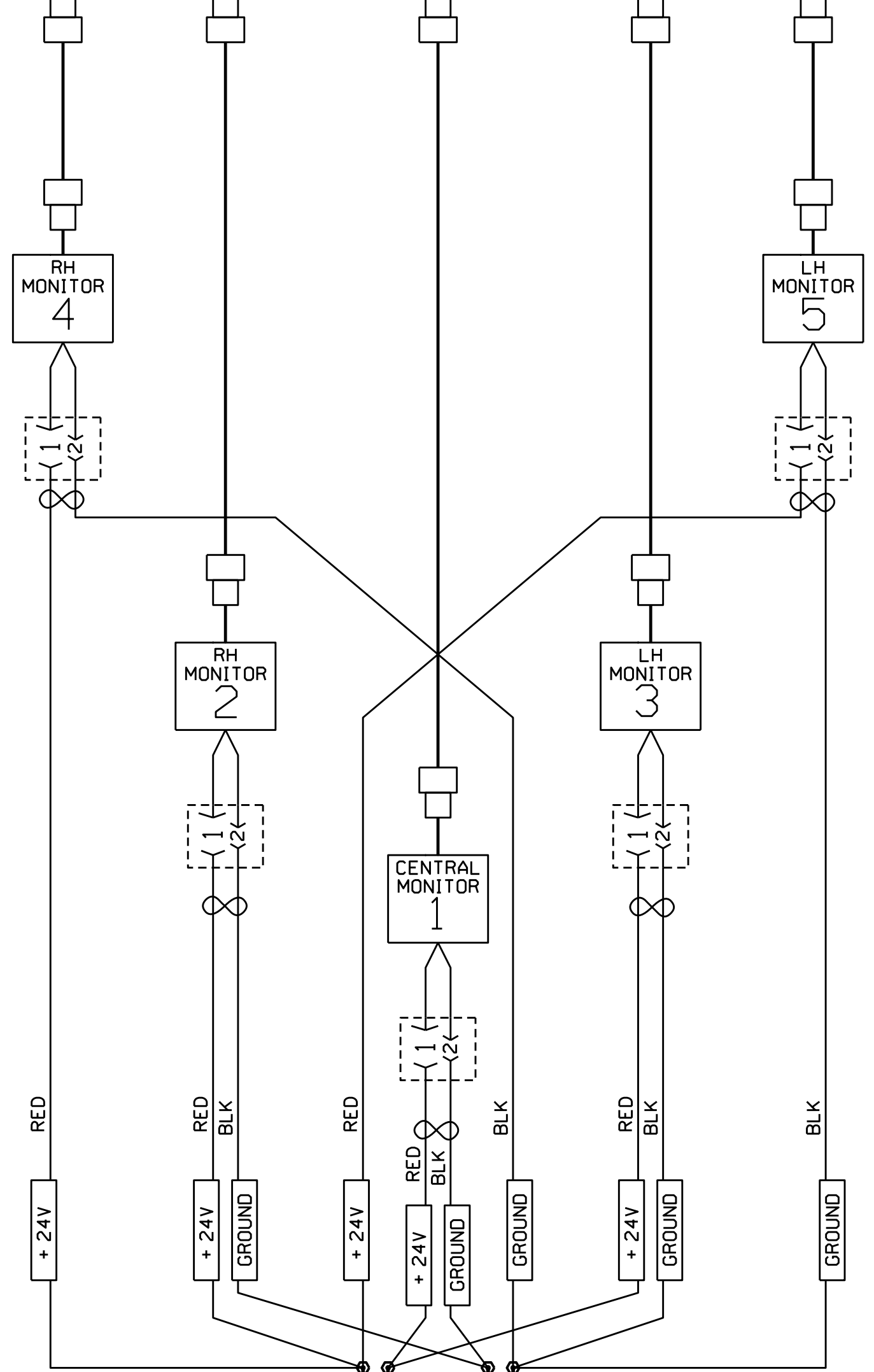

FROM CONTROL HEAD CONNECTION VCP #18 SEE P 20.1

VCP AUDIO OUT TO SEAT AUDIO SYSTEM SEE P 20.6

## VIDEO SYSTEM

TO FRONT CAMERA SEE P. 20.7

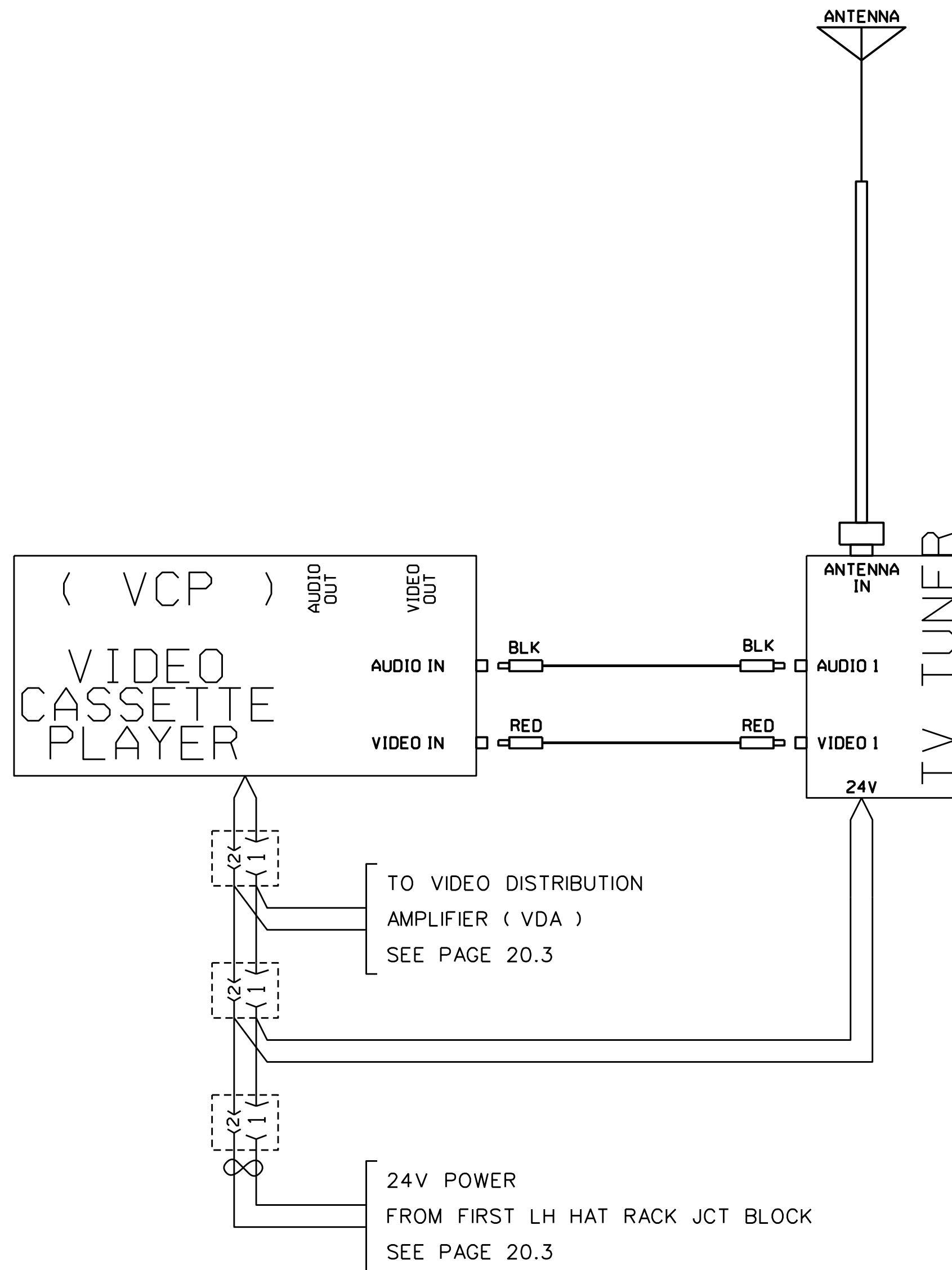

TV RECEIVER

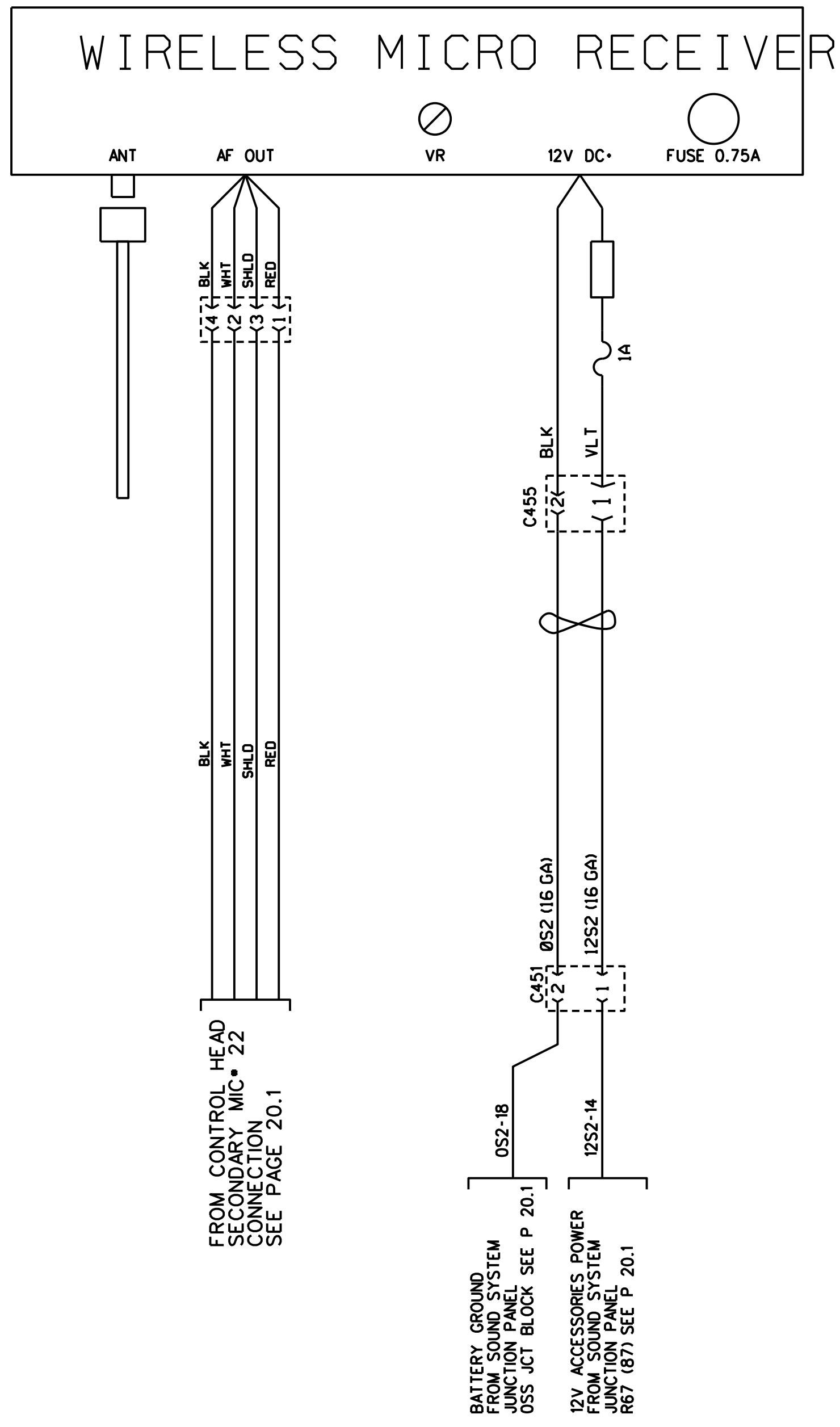

WIRELESS MICROPHONE



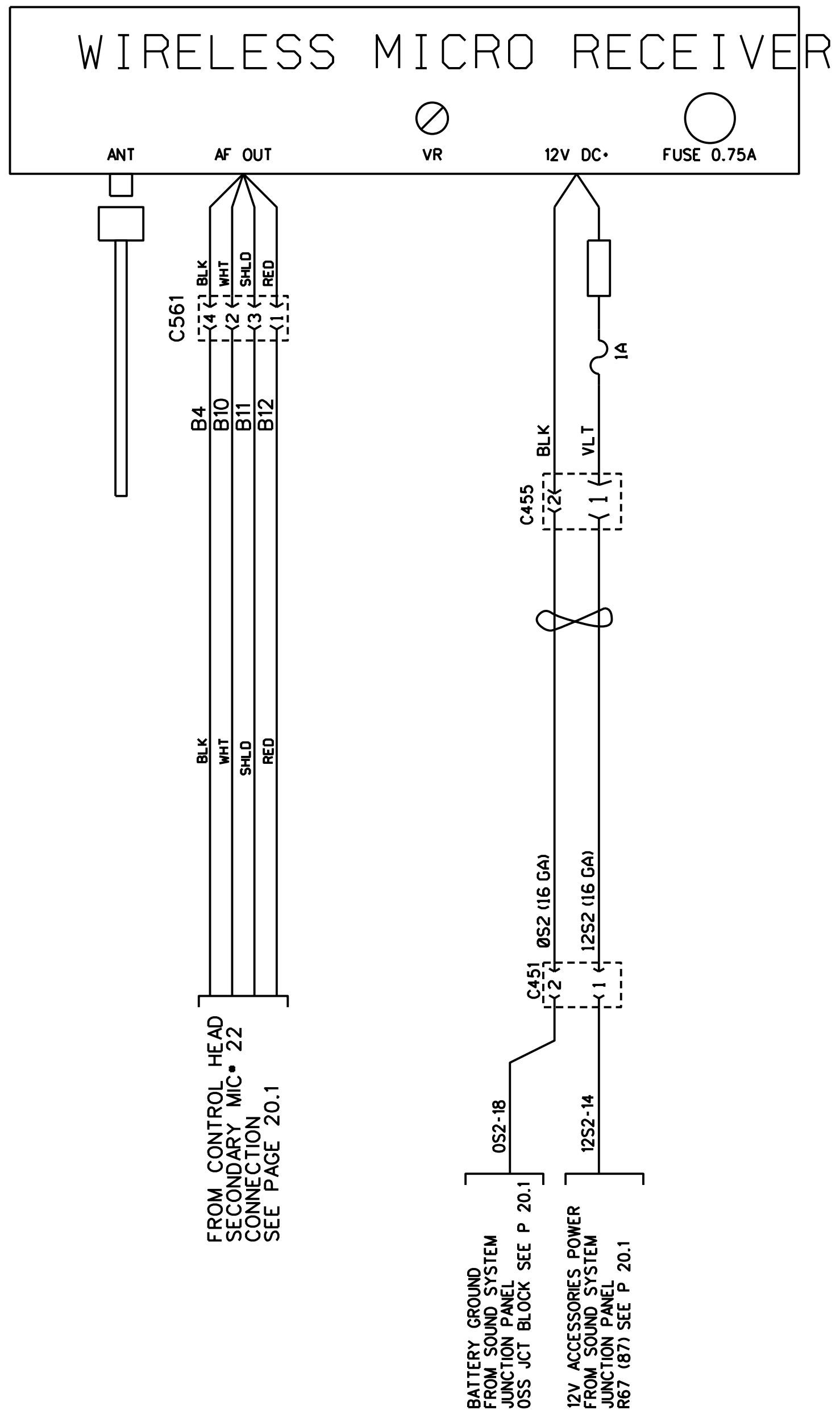

WIRELESS MICROPHONE

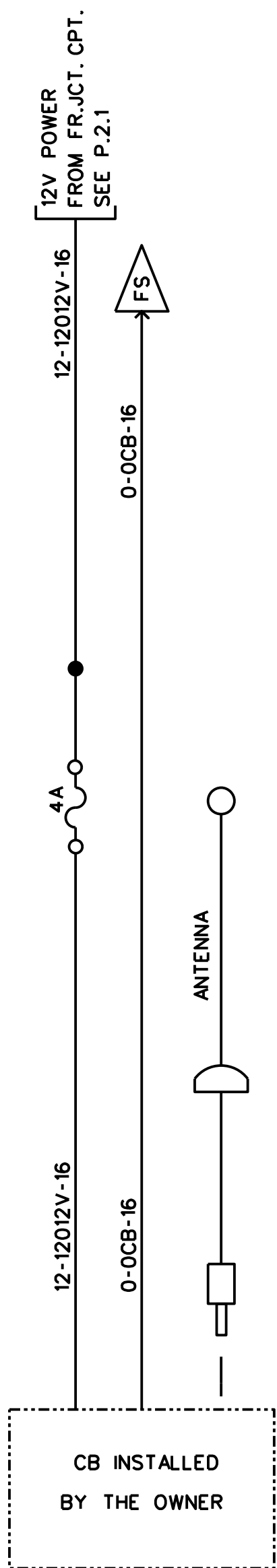

CB OPTION

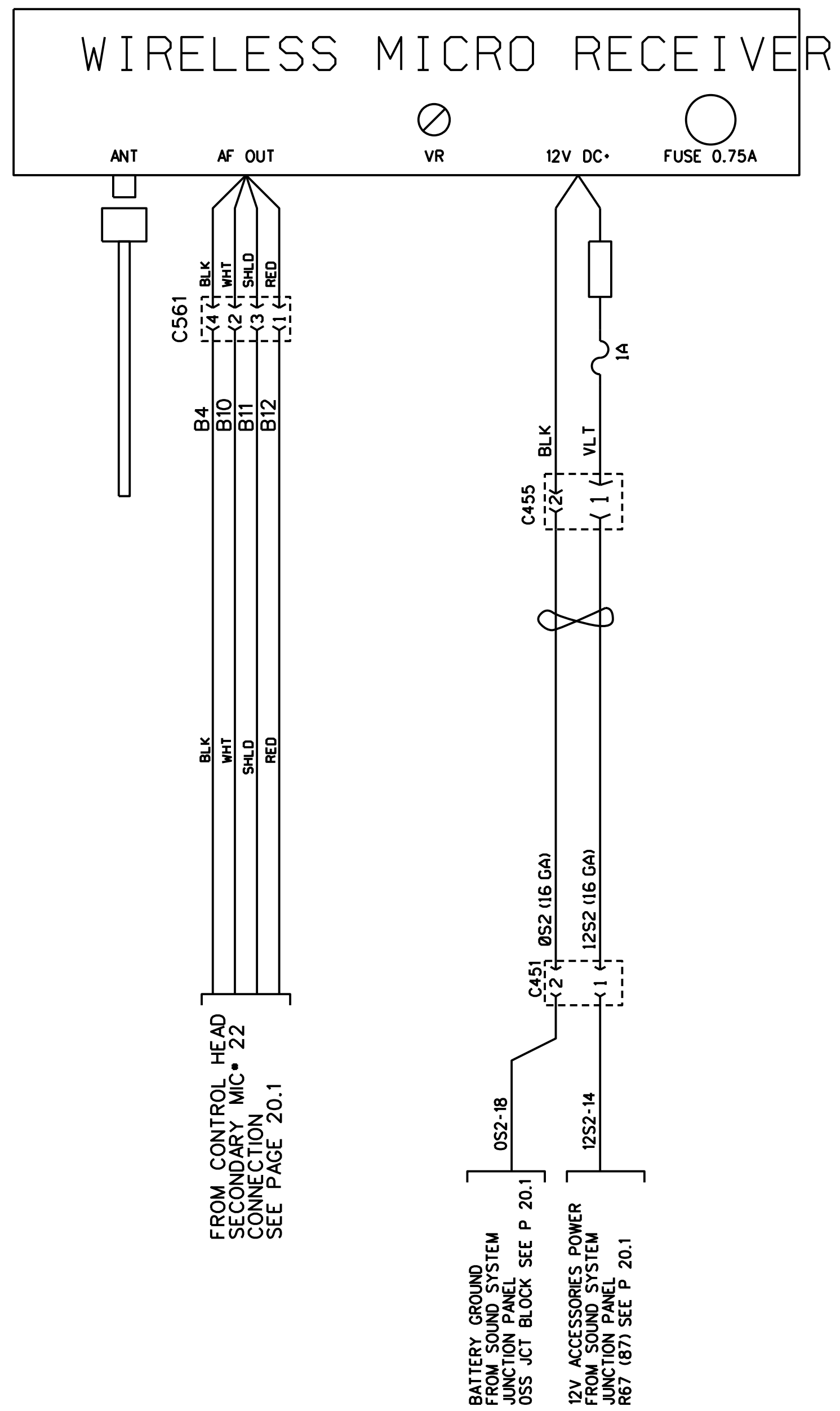

WIRELESS MICROPHONE

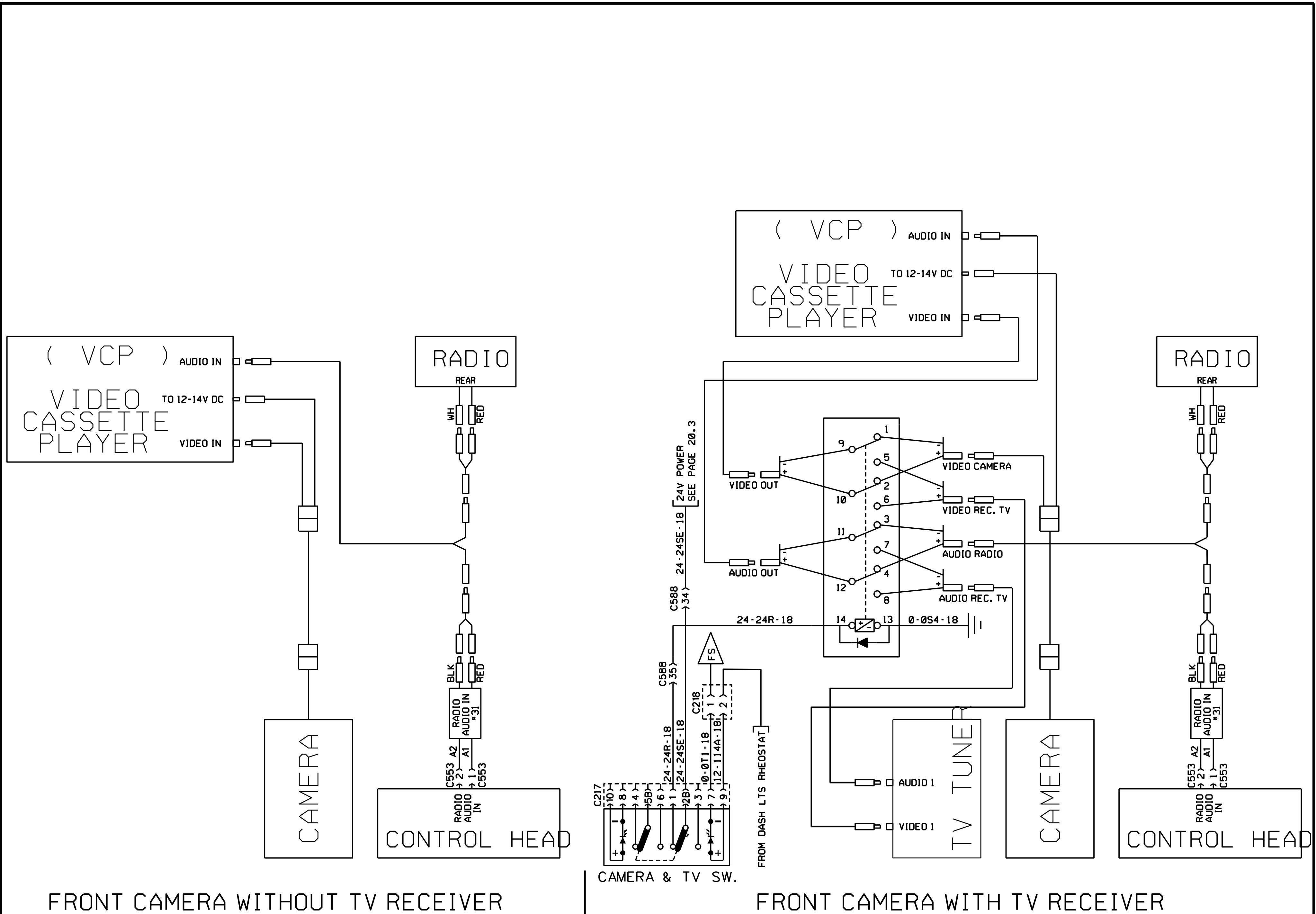

FRONT CAMERA WITHOUT TV RECEIVER

FRONT CAMERA WITH TV RECEIVER

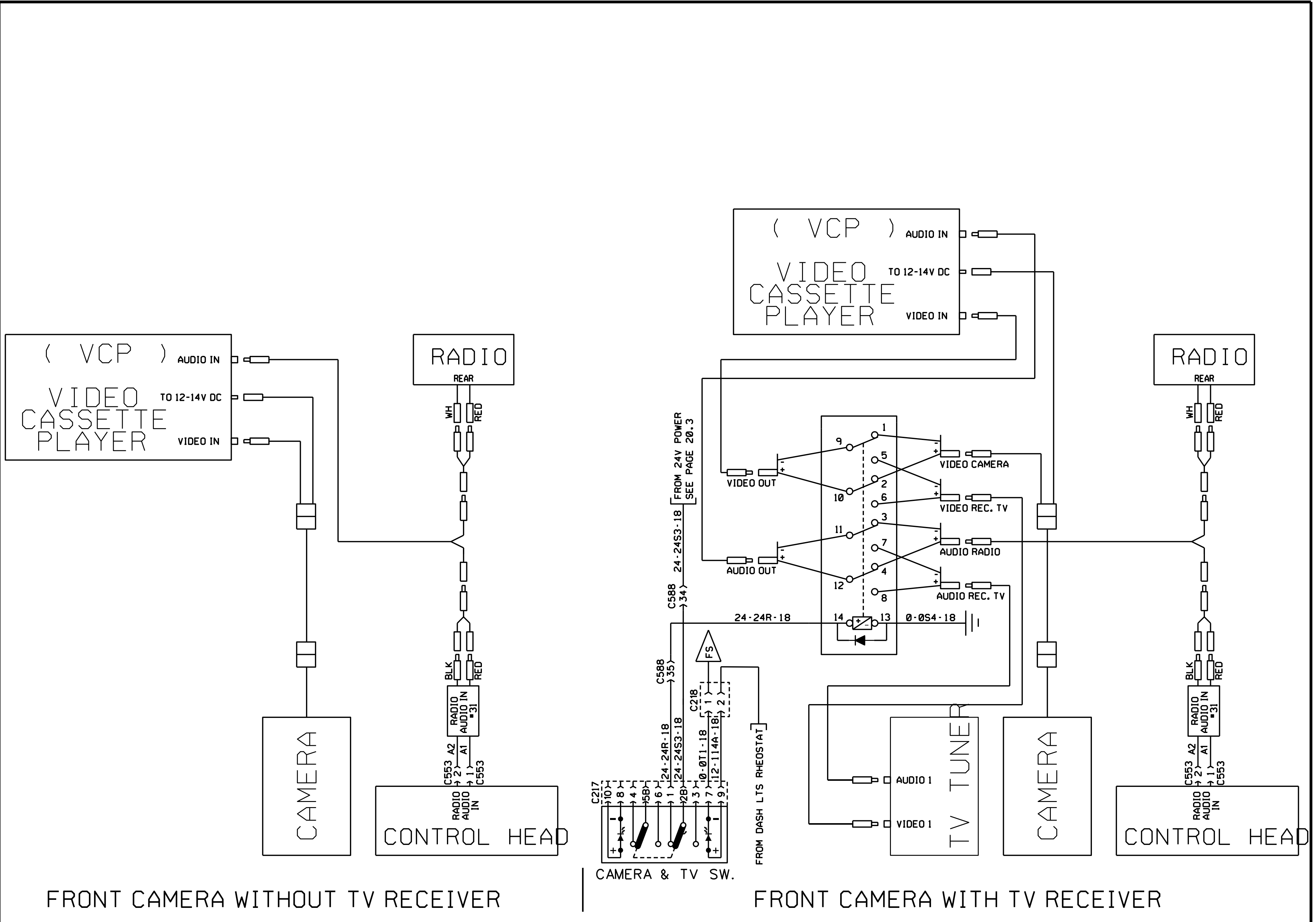

FRONT CAMERA WITHOUT TV RECEIVER

FRONT CAMERA WITH TV RECEIVER

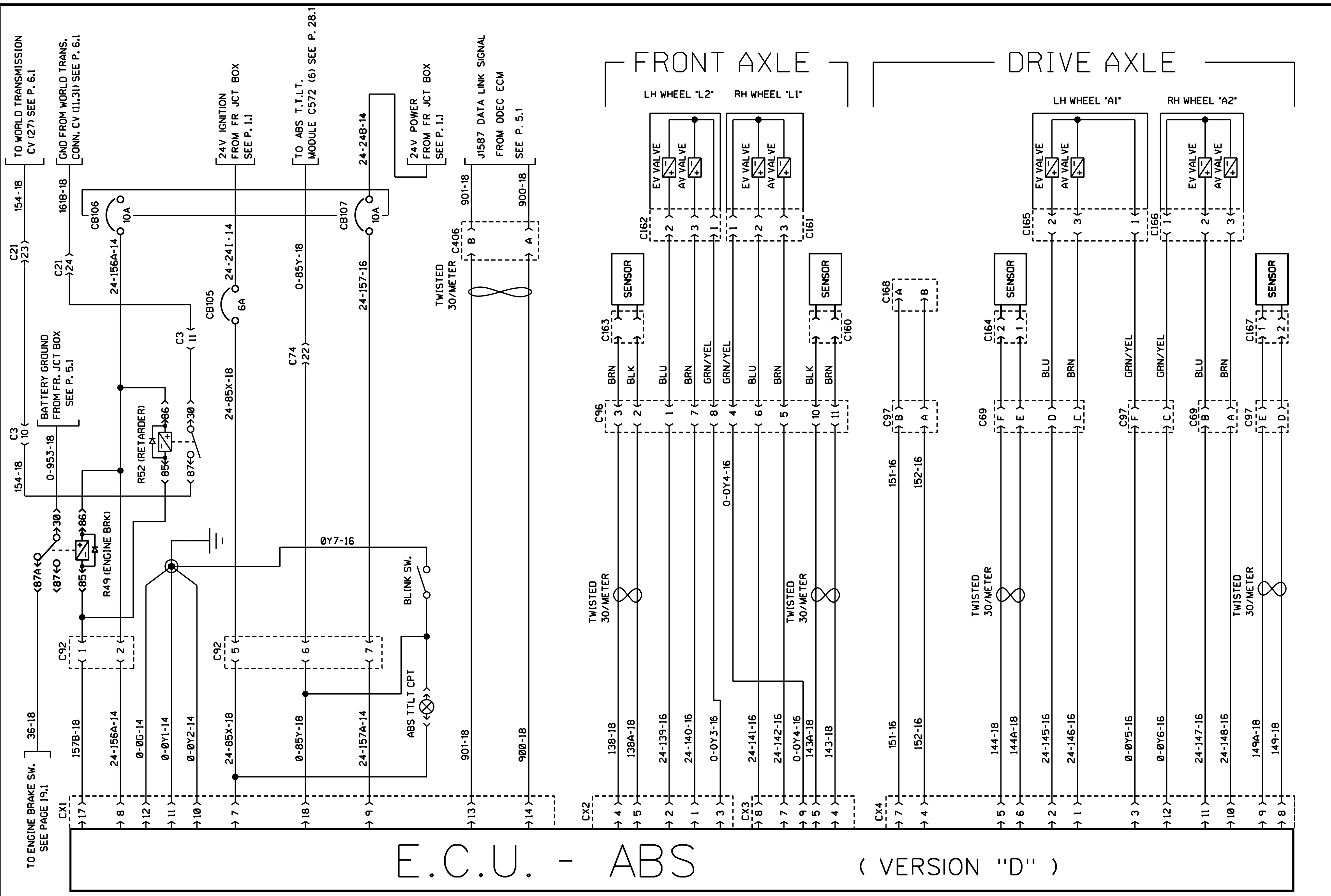

E.C.U. - ABS

( VERSION "D" )

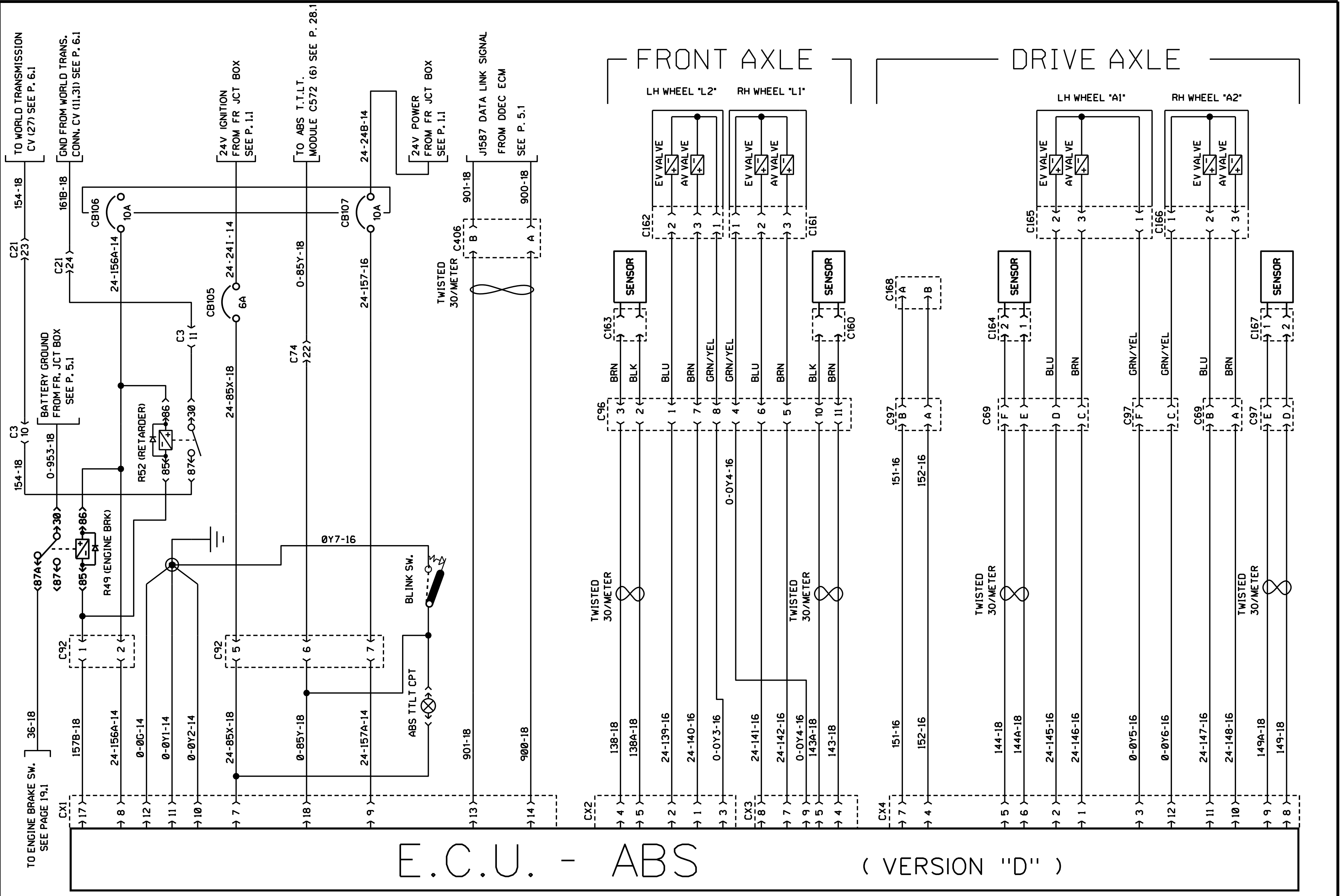

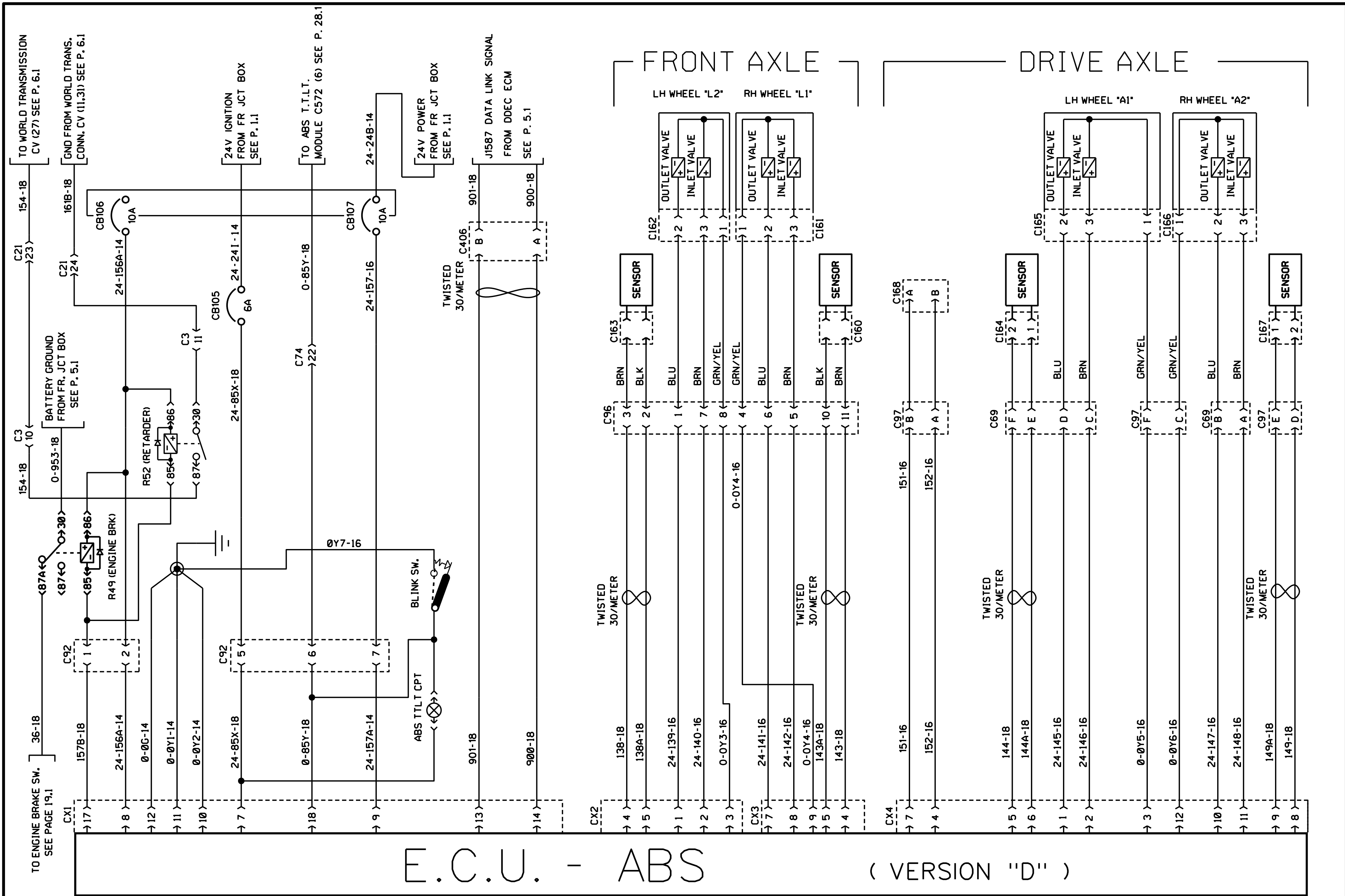

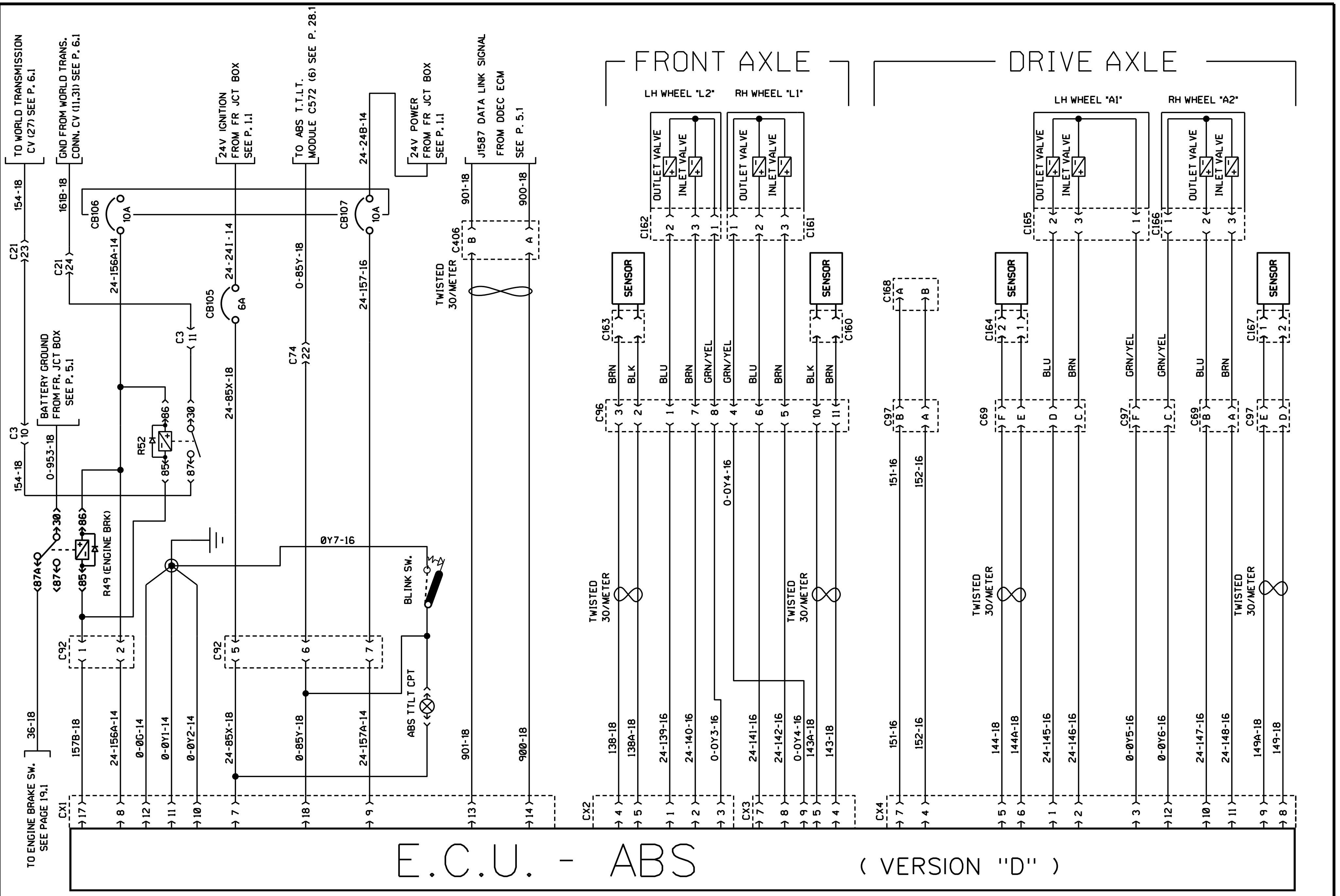



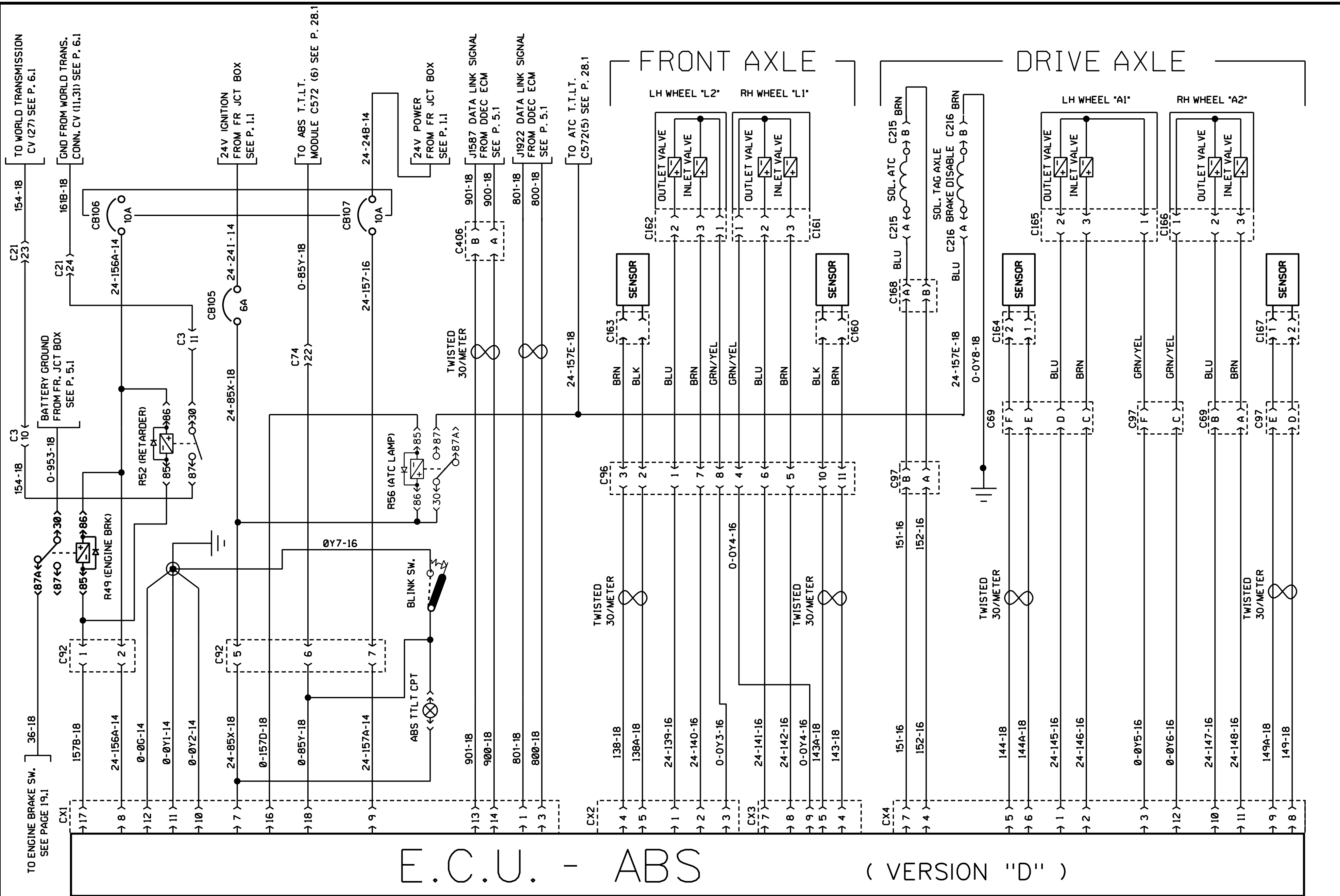

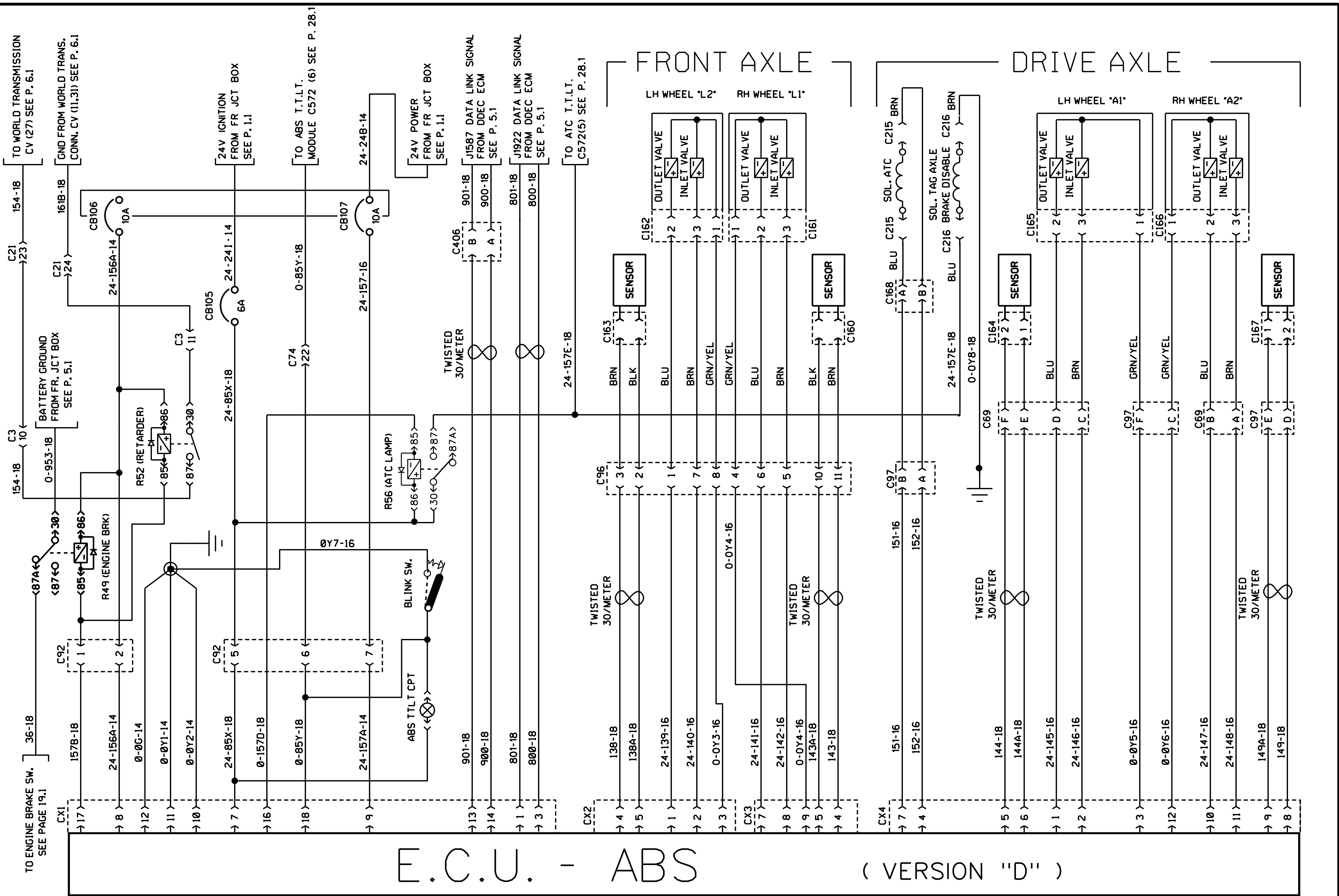

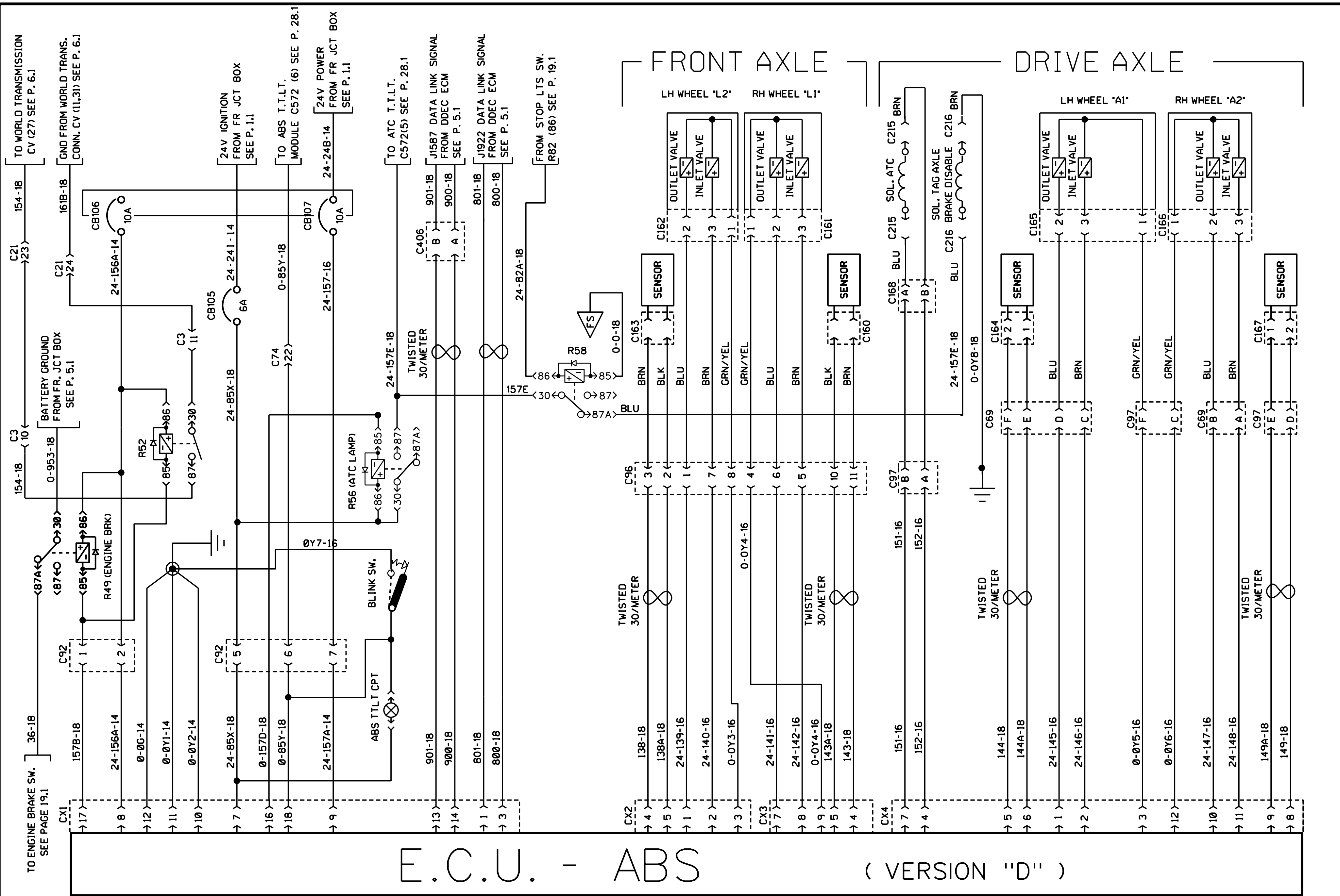

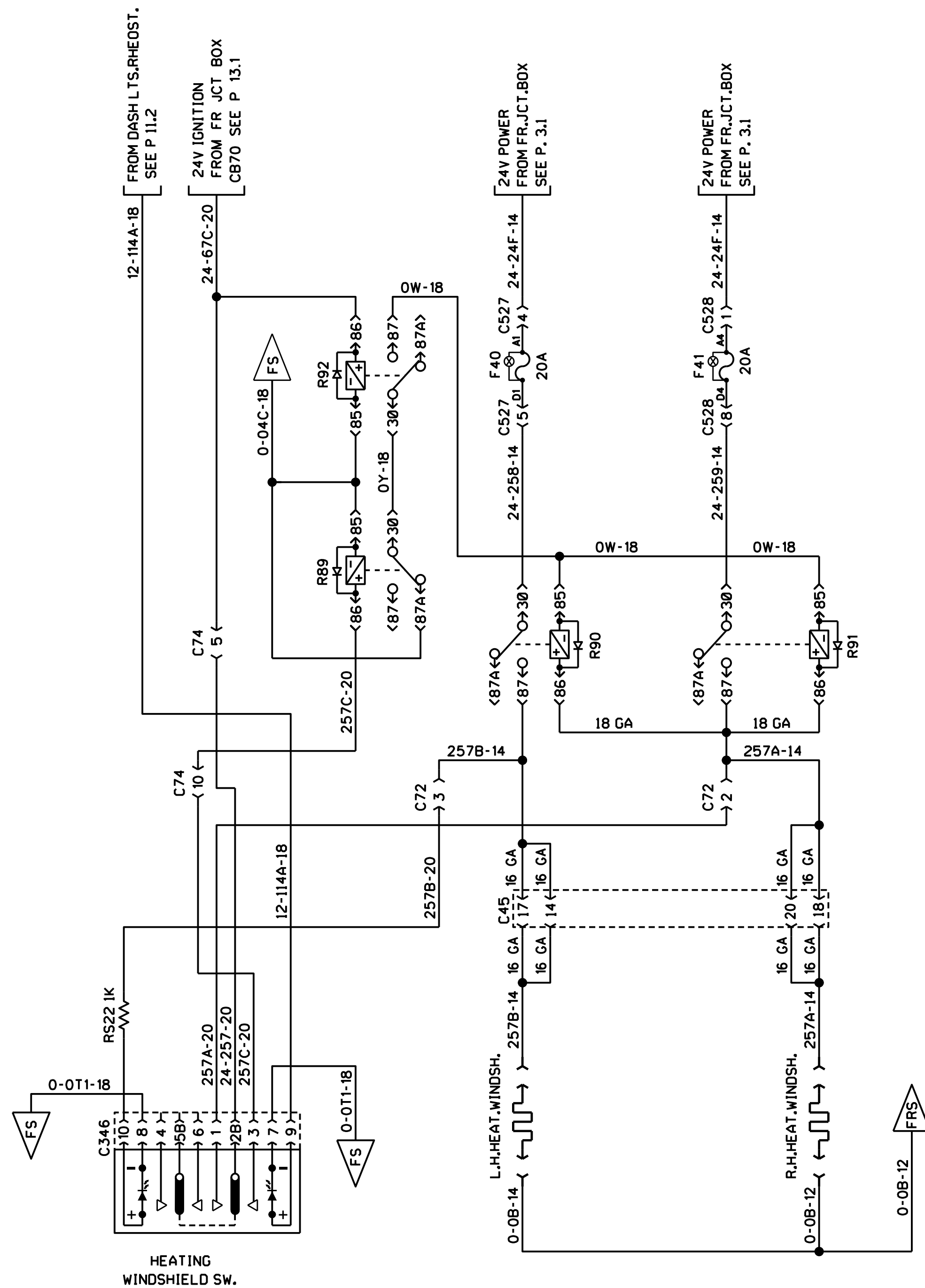
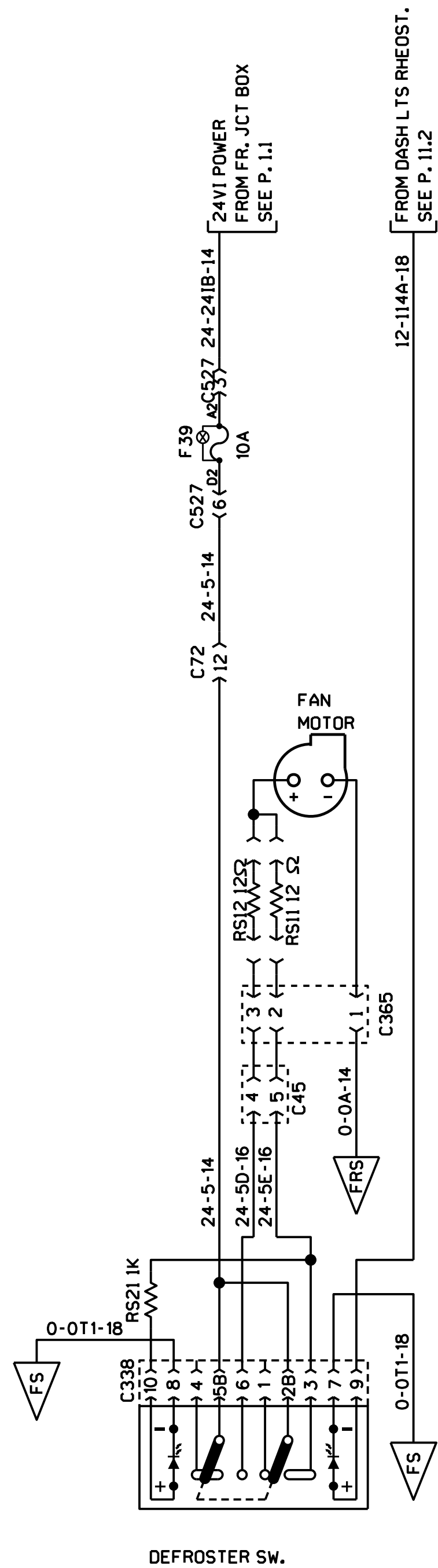
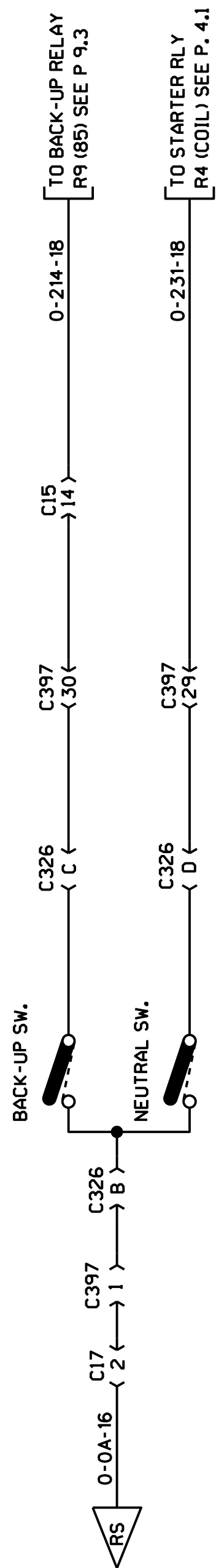

MANUAL TRANSMISSION

UPPER WINDSHIELD DEFROST

UPPER HEATED WINDSHIELD

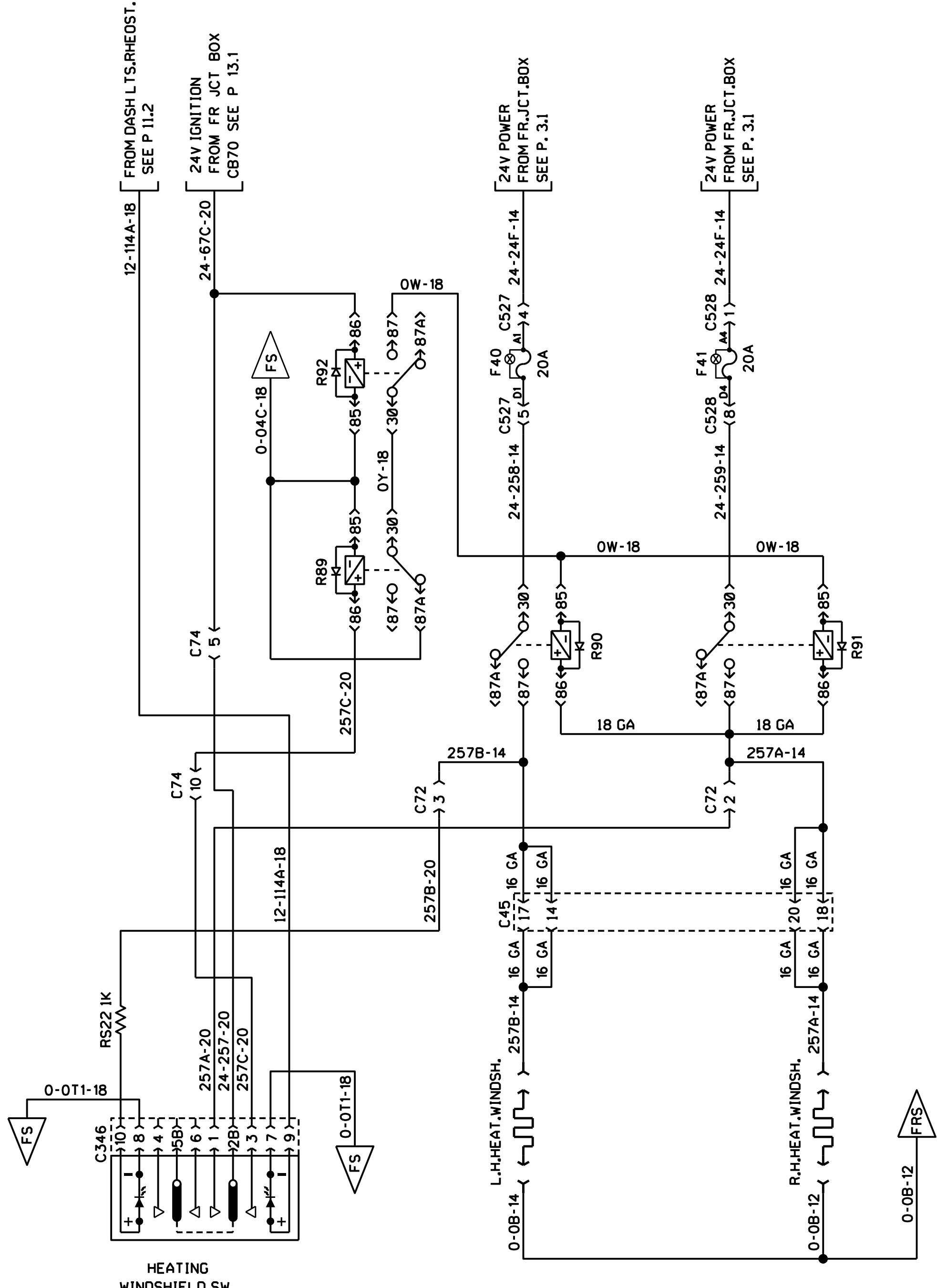
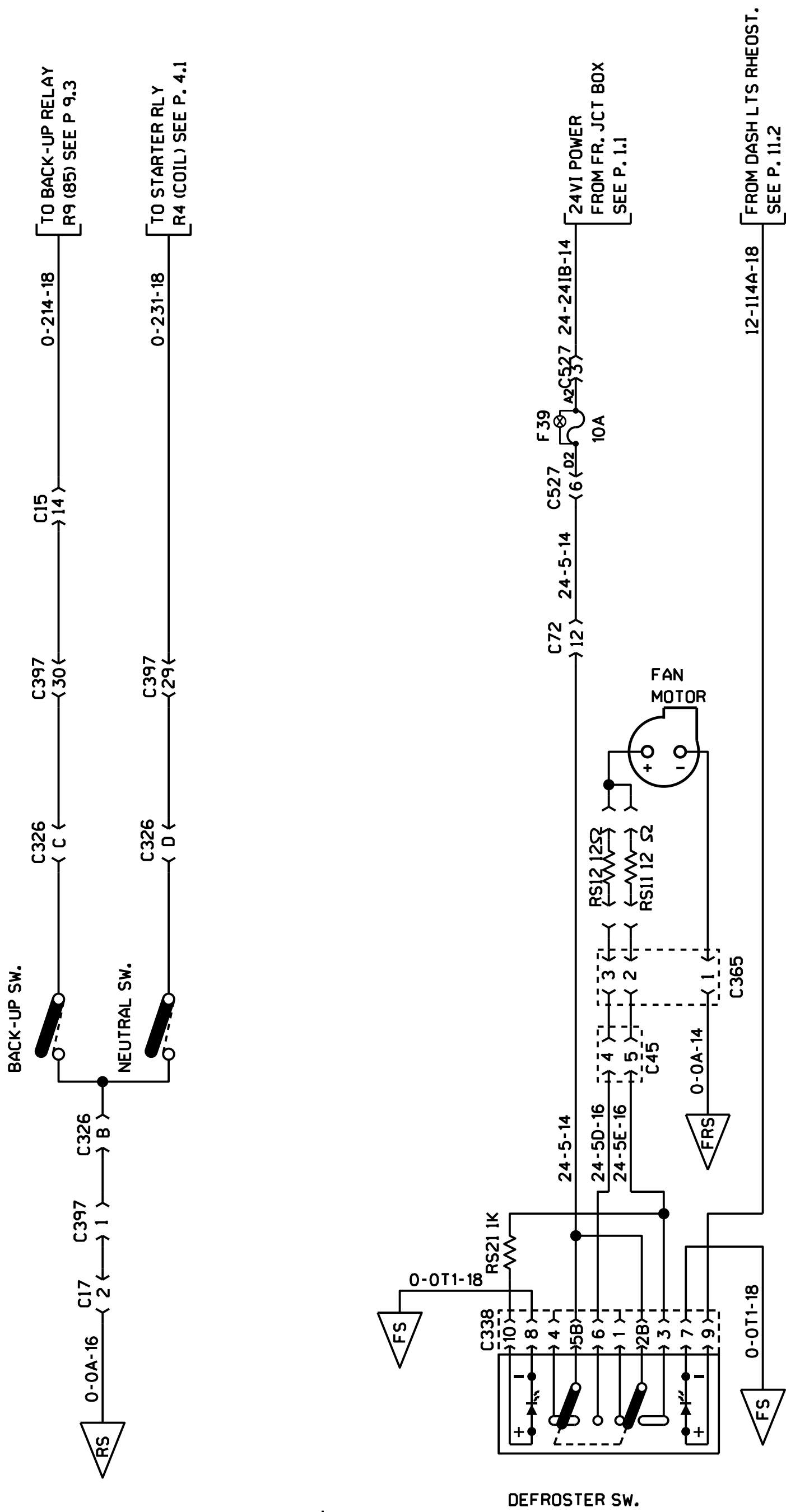

MANUAL TRANSMISSION

UPPER WINDSHIELD DEFROST

UPPER HEATED WINDSHIELD

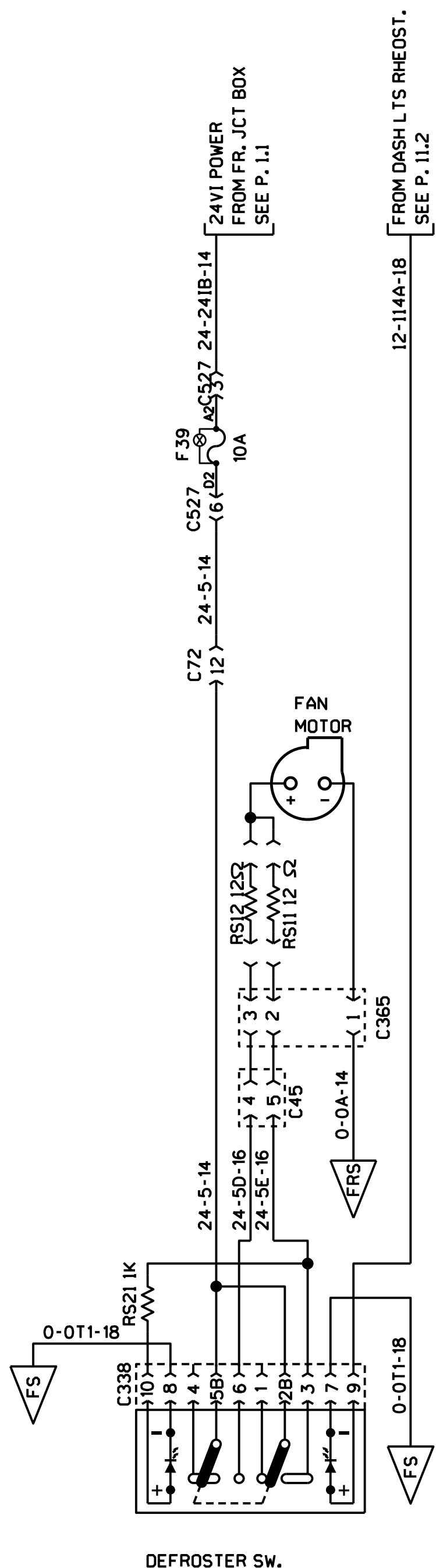

UPPER WINDSHIELD DEFROST

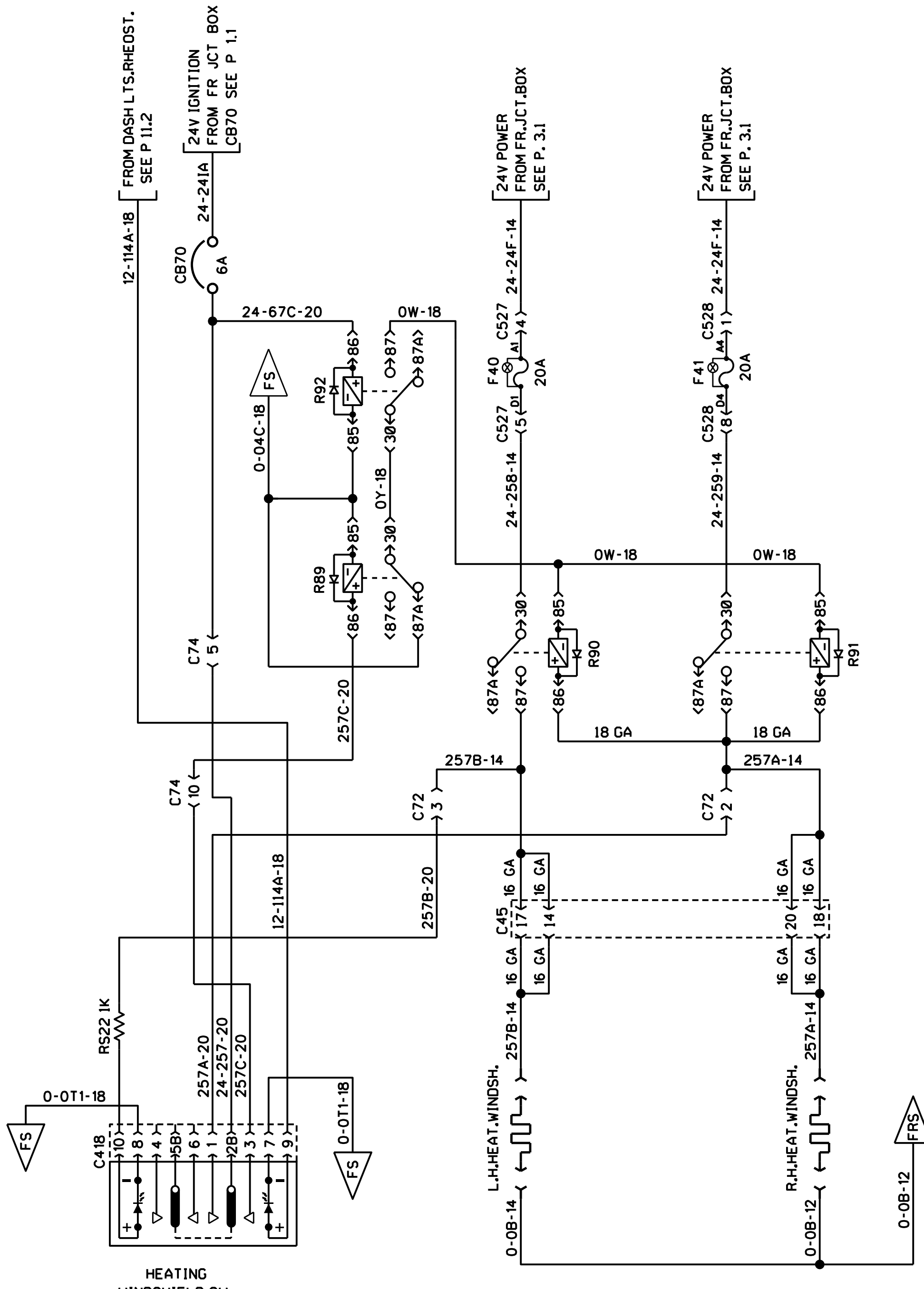

UPPER HEATED WINDSHIELD

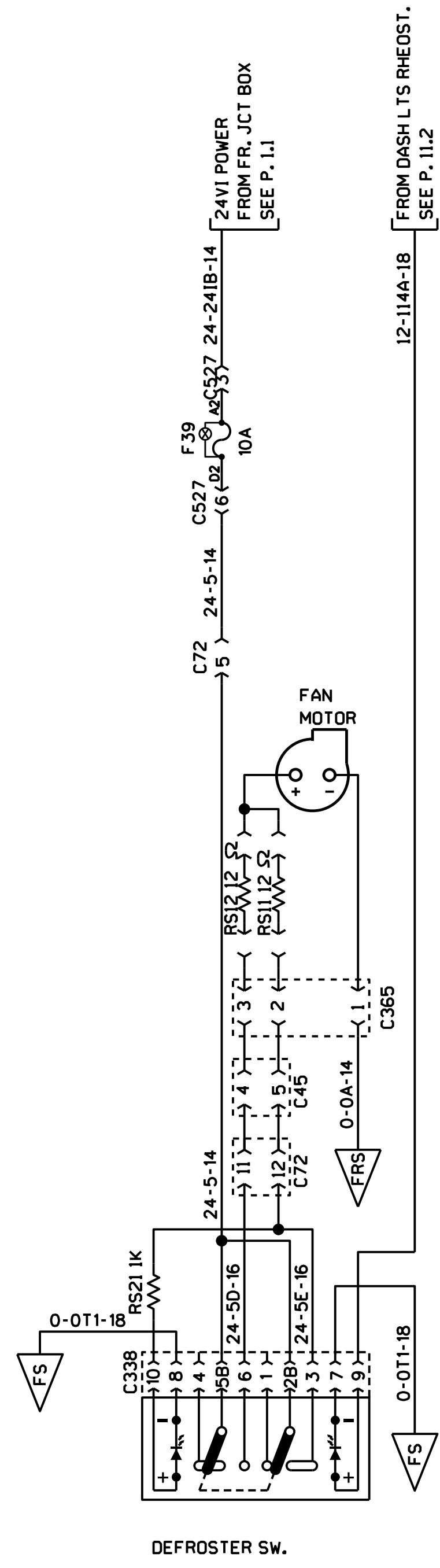

UPPER WINDSHIELD DEFROST

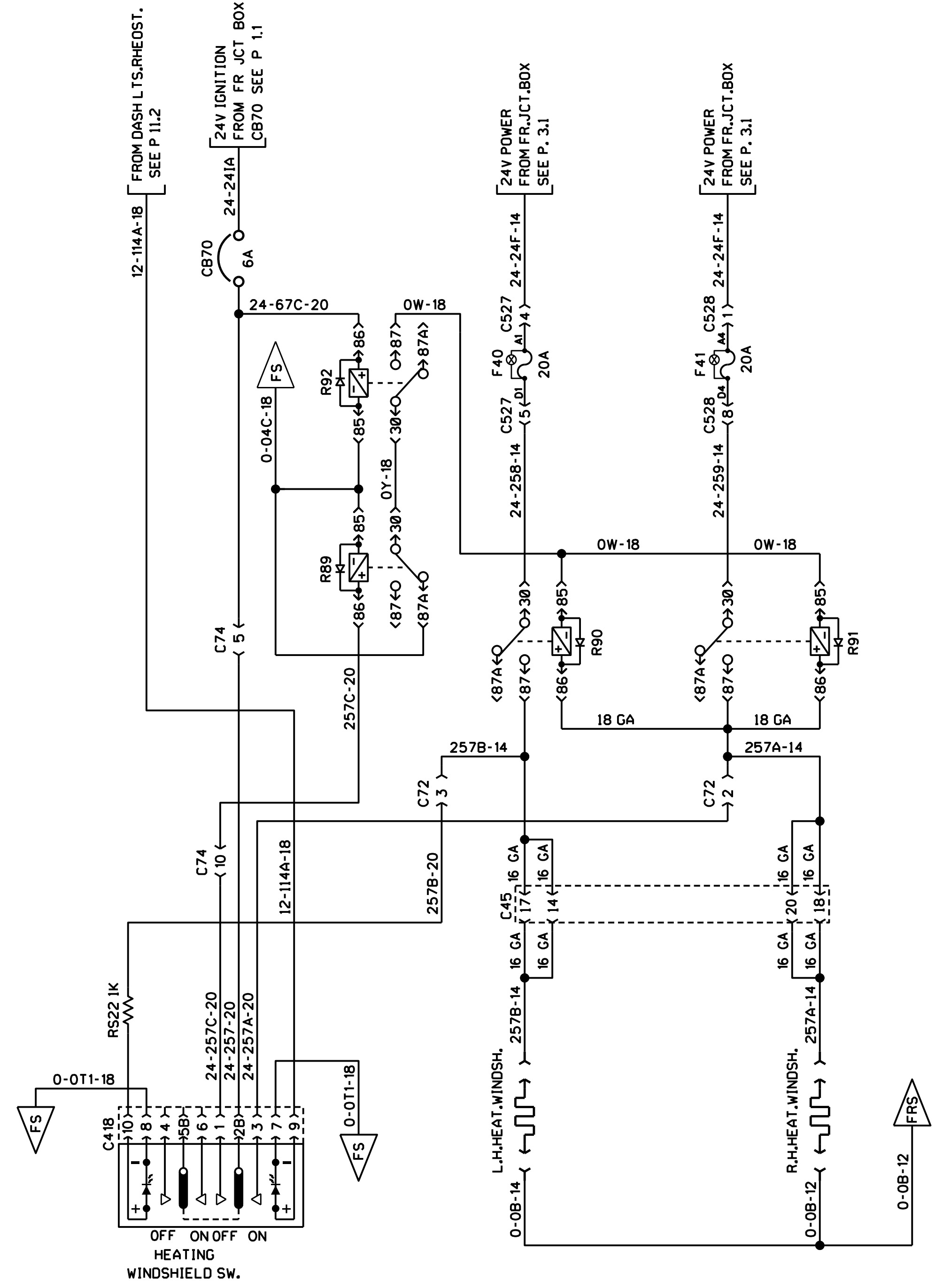

UPPER HEATED WINDSHIELD

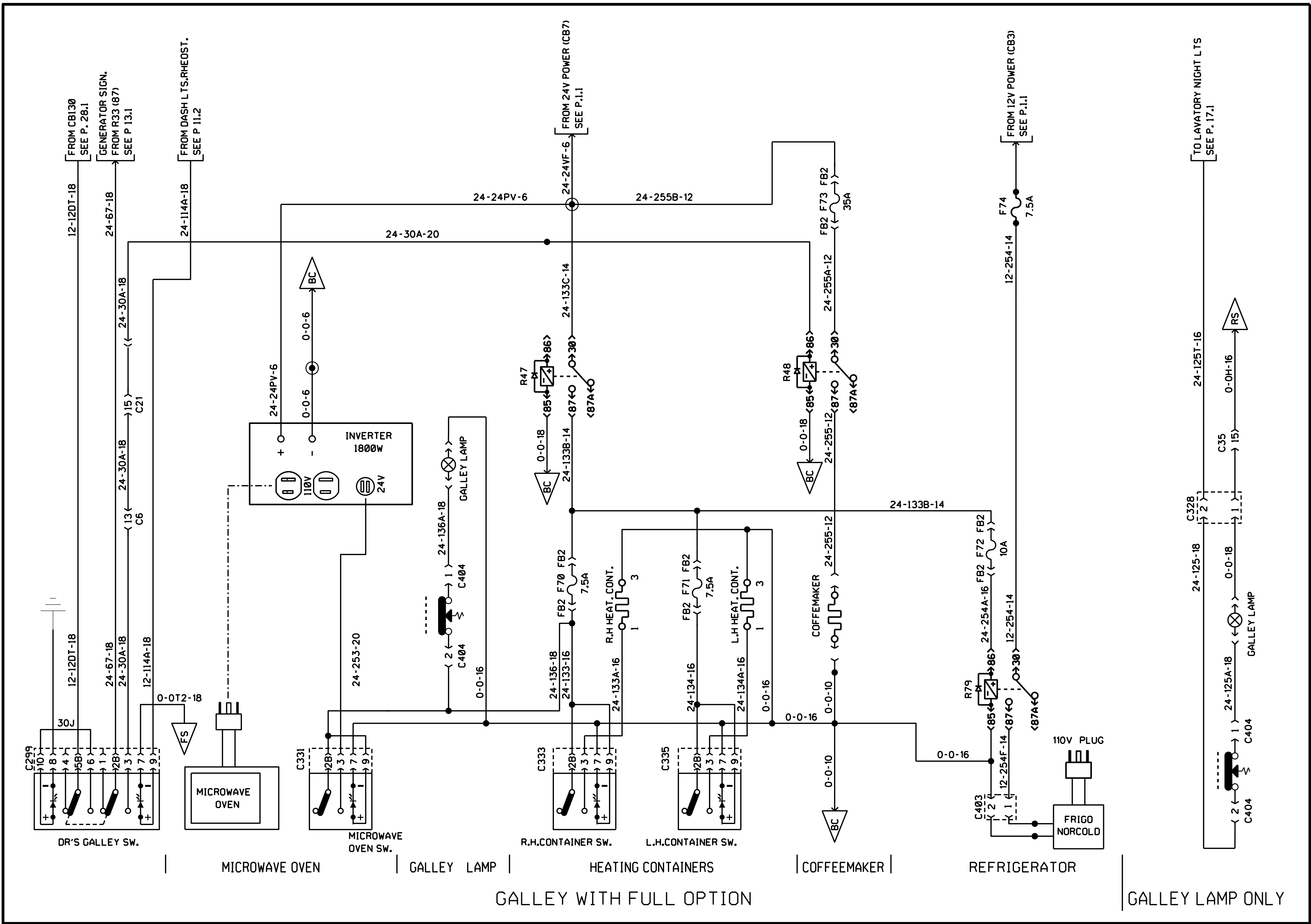



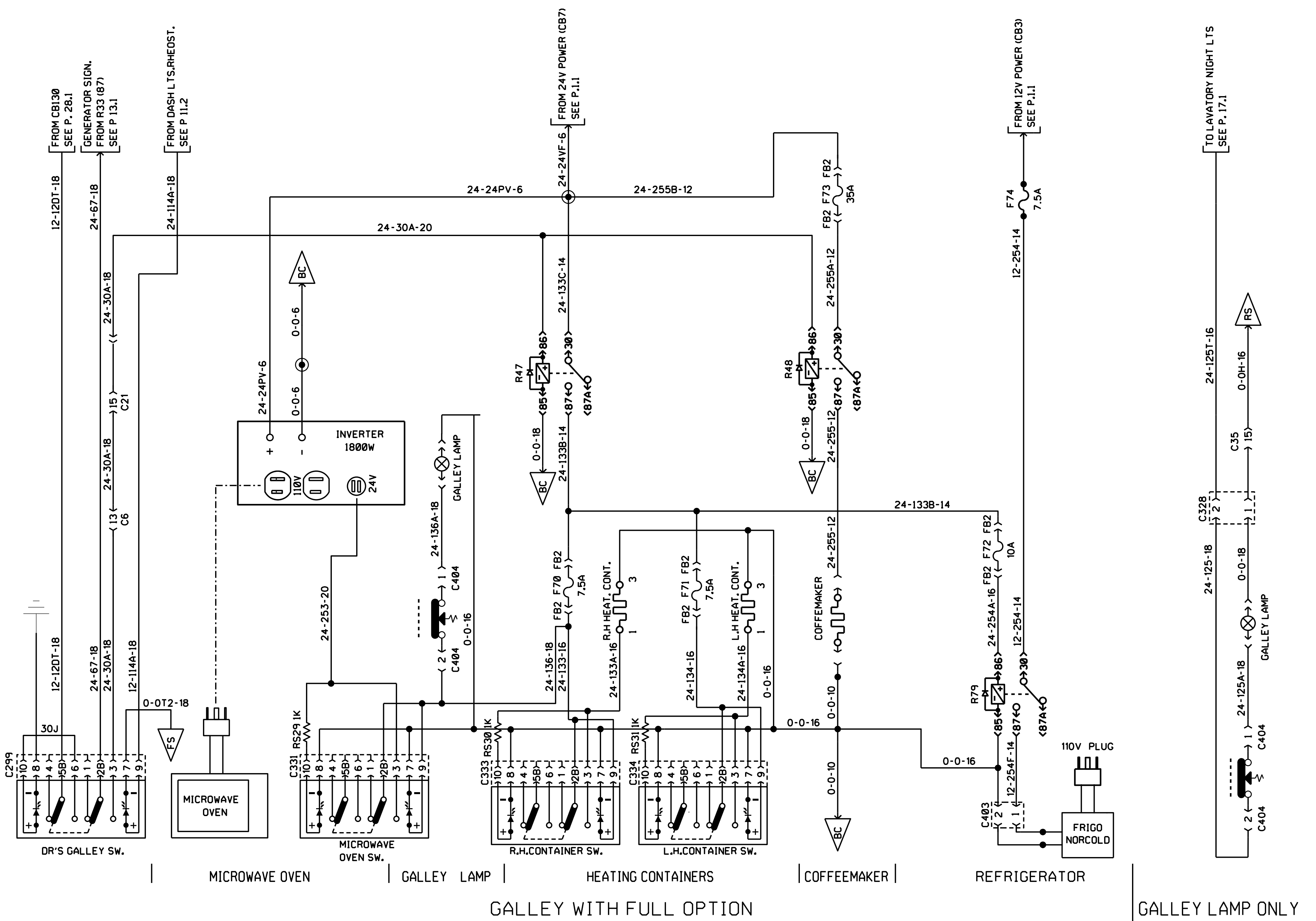

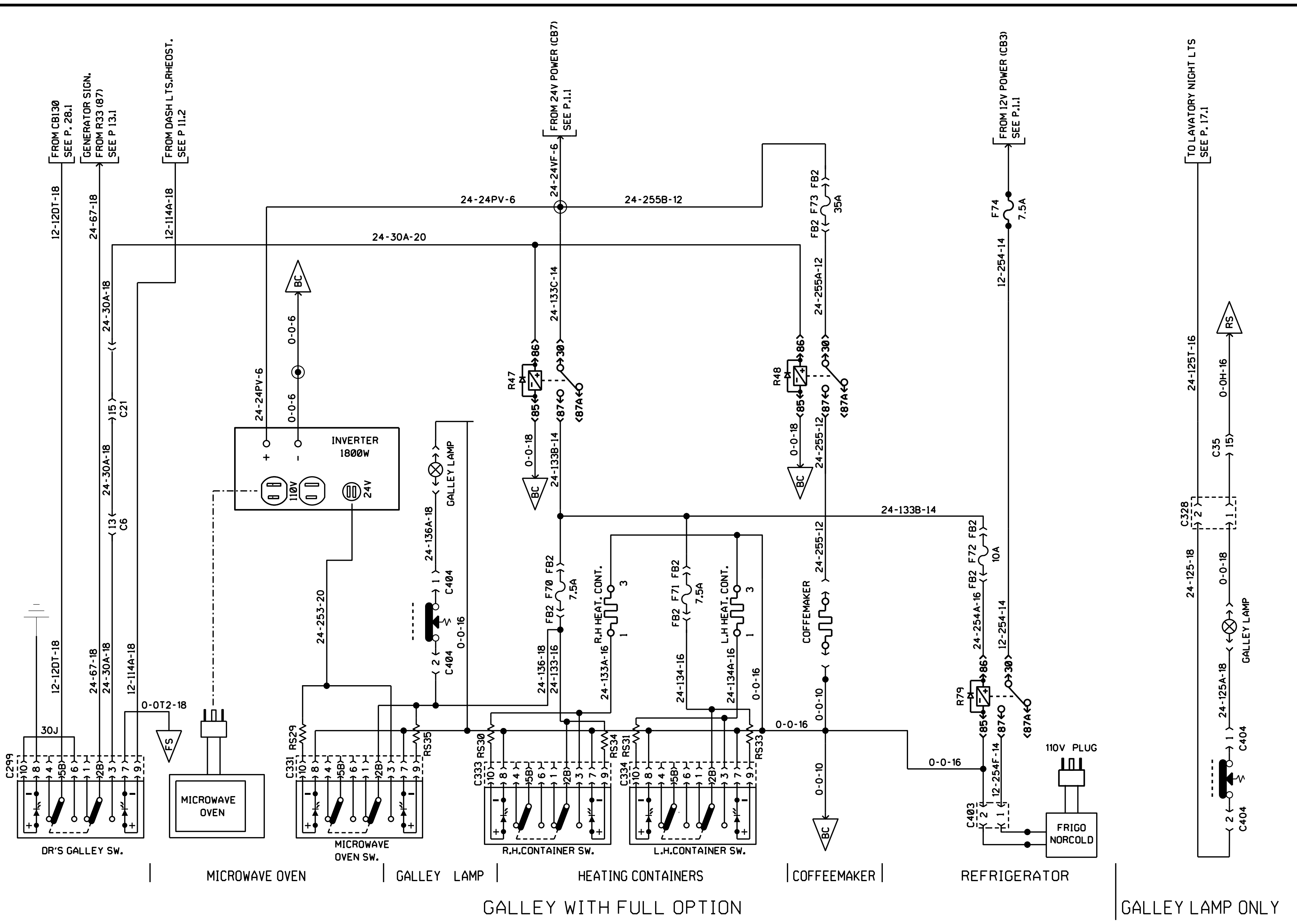

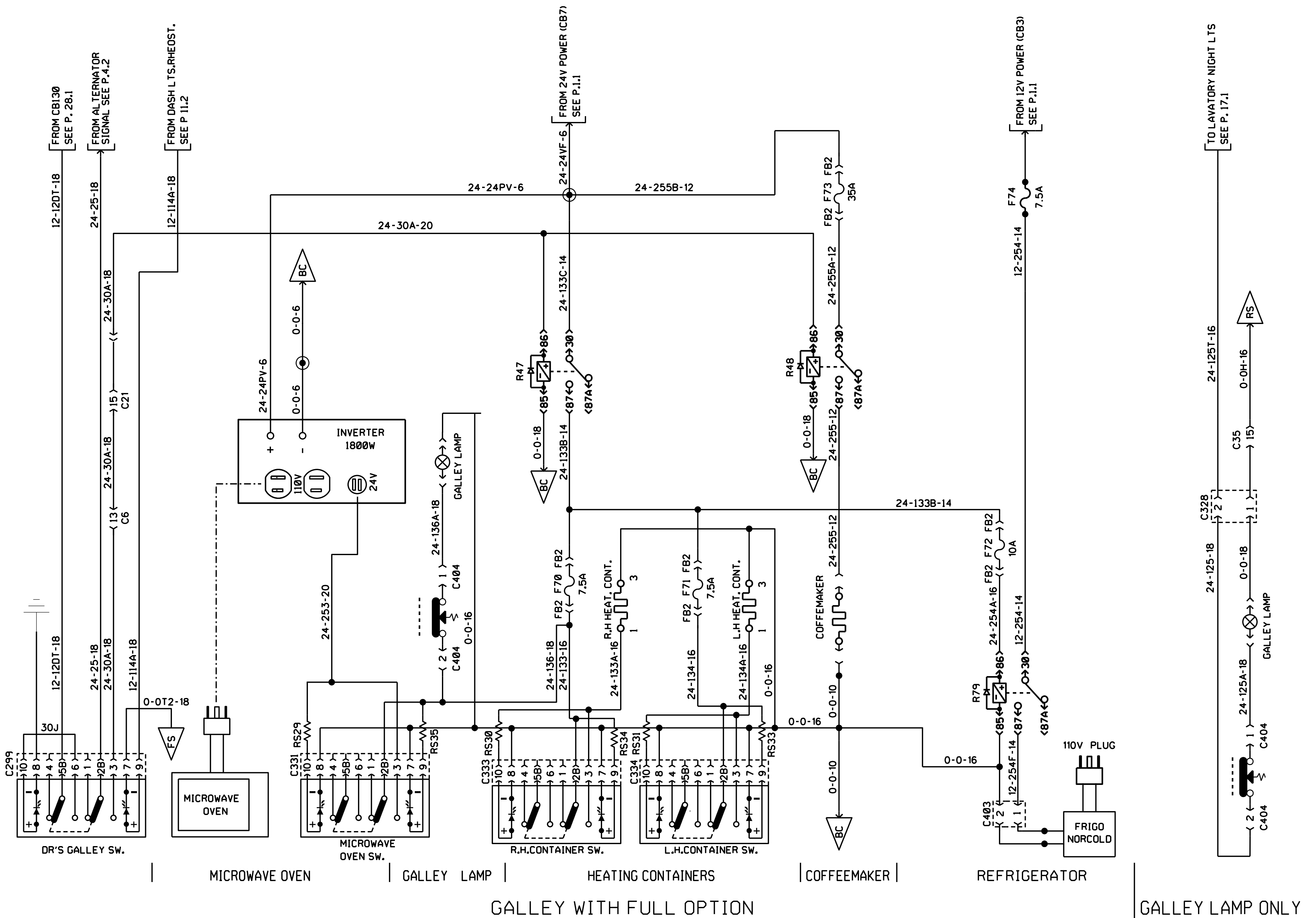

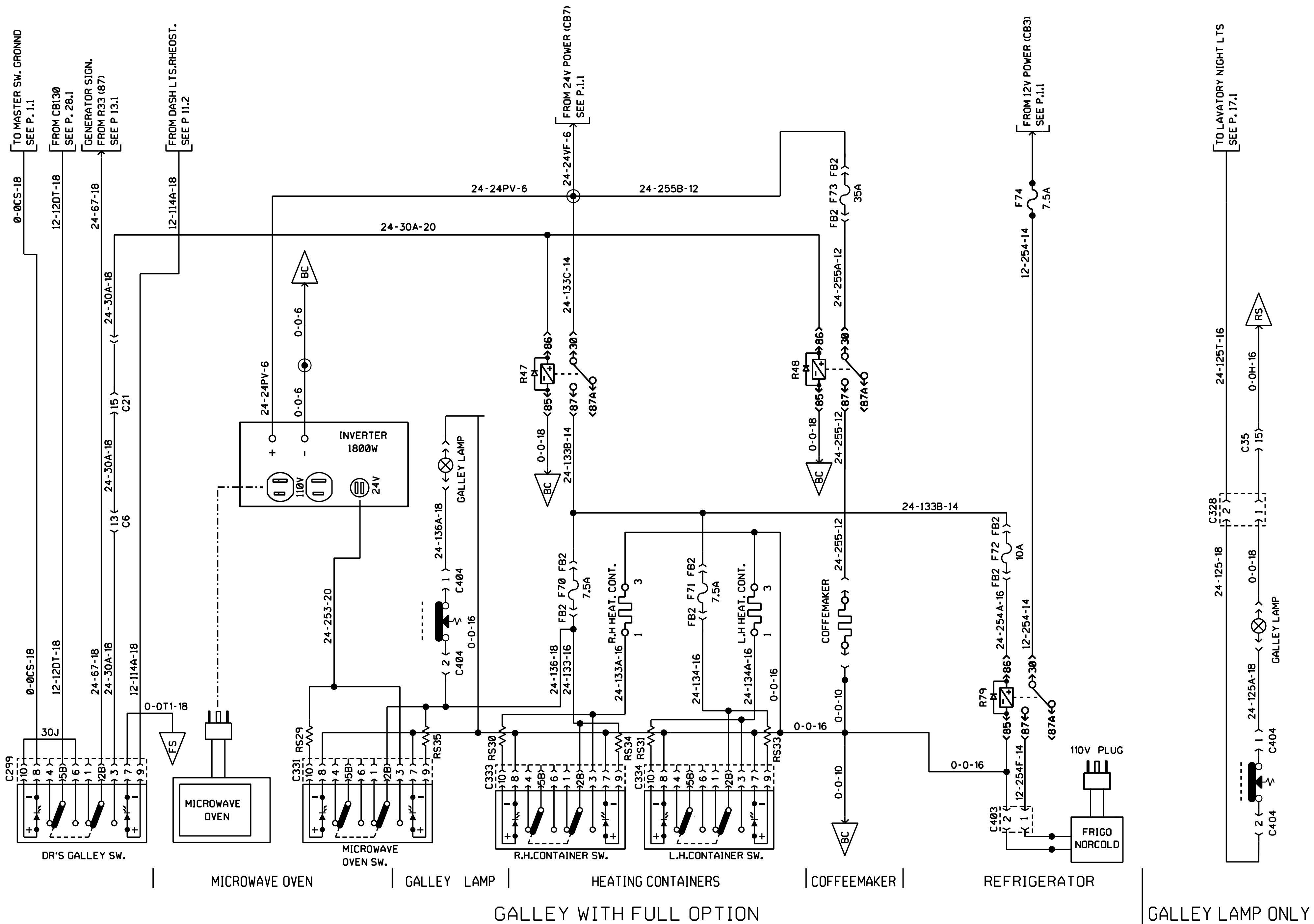

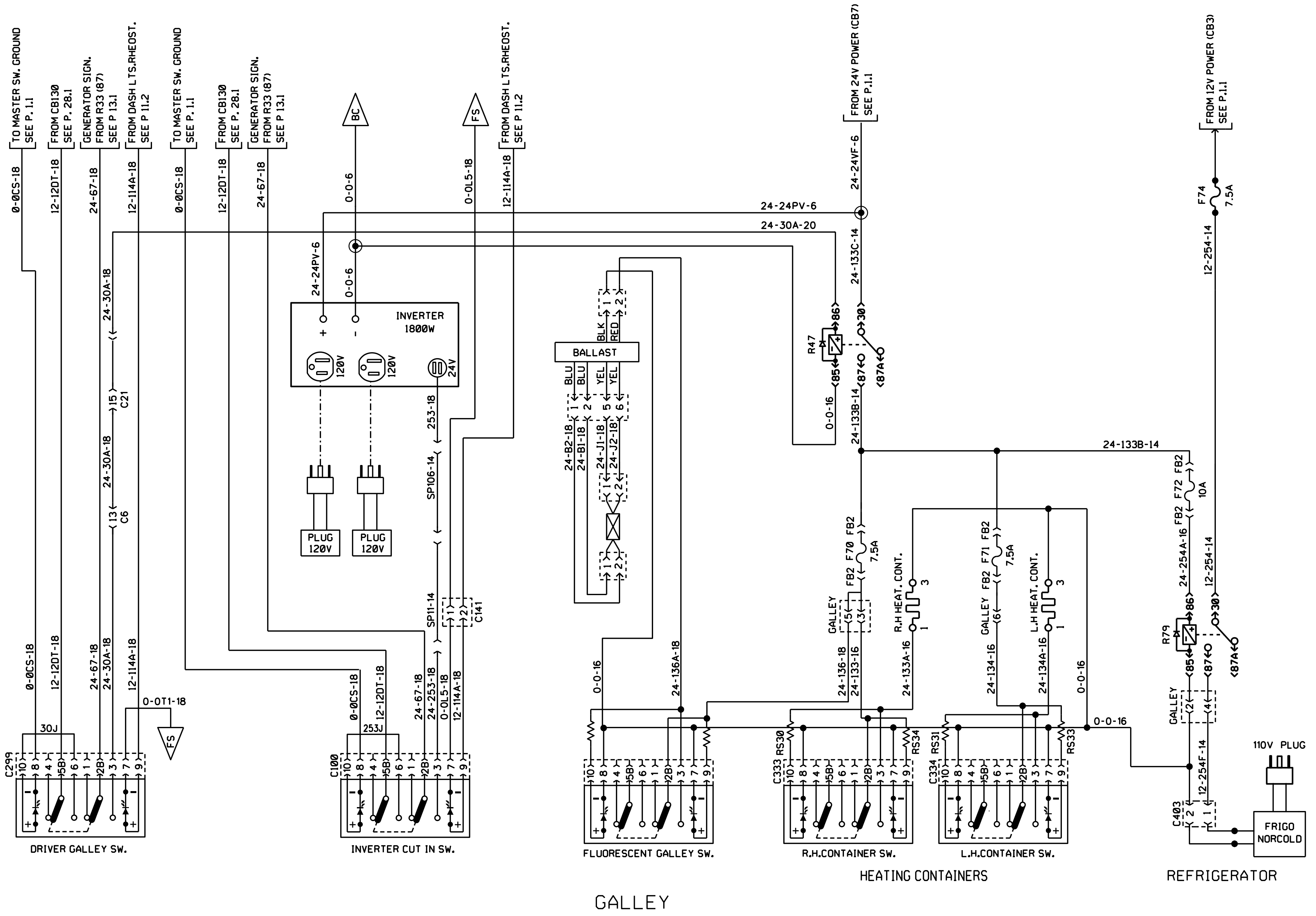

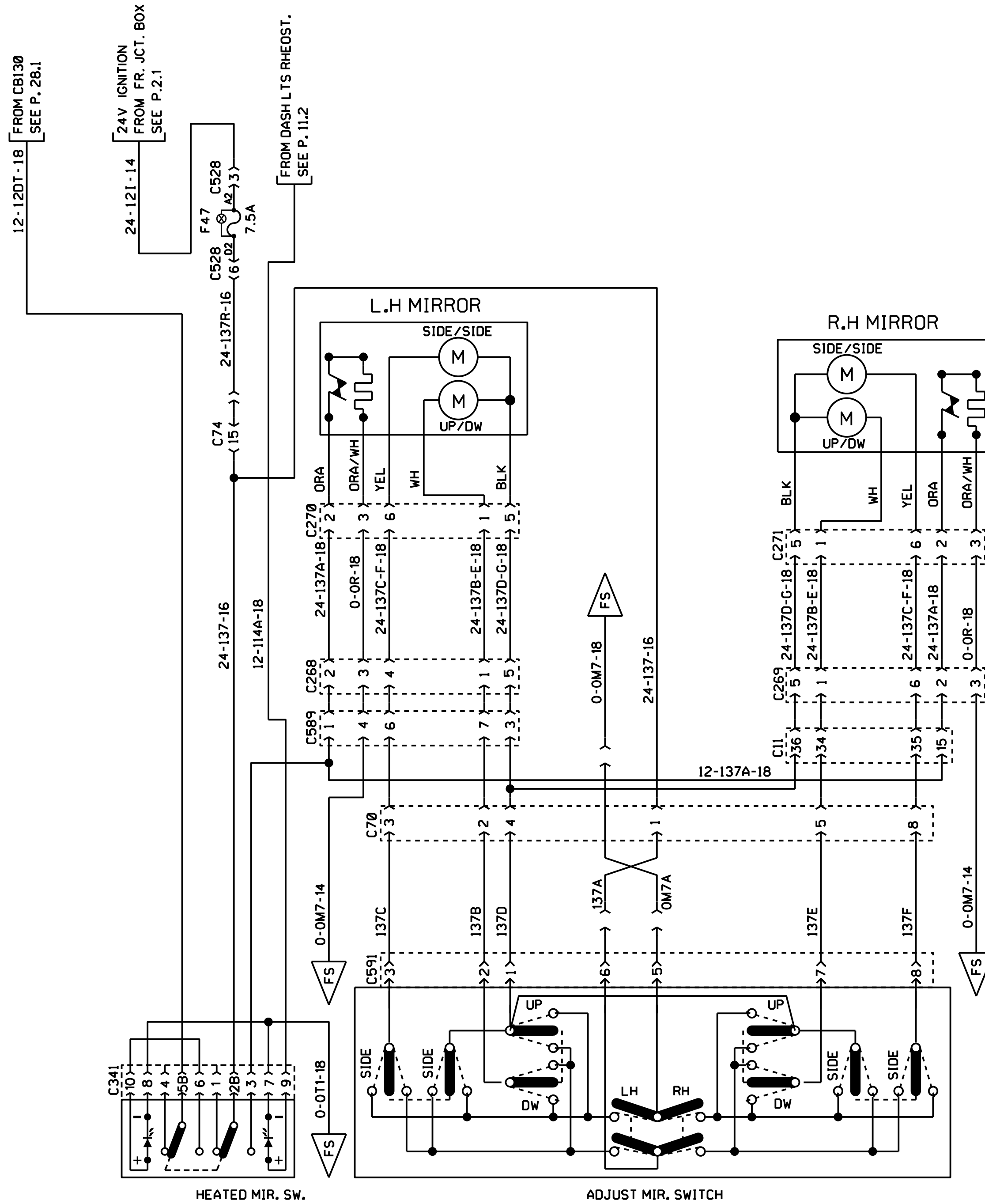

REAR VIEW MIRROR SPARTAN - 1 ADJUSTMENT SW. & 1 HEATED SW.

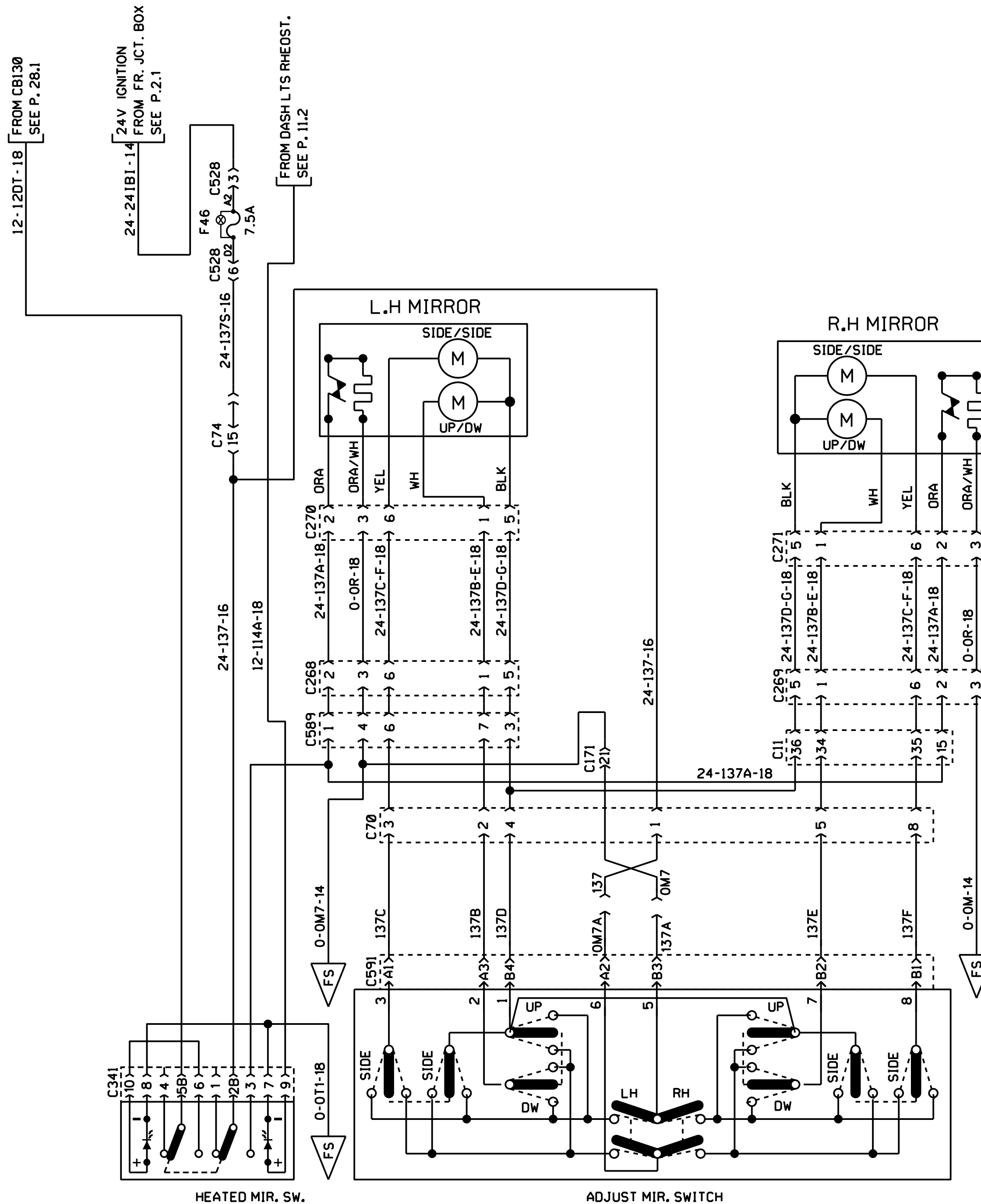

REAR VIEW MIRROR SPARTAN - 1 ADJUSTMENT SW. & 1 HEATED SW.

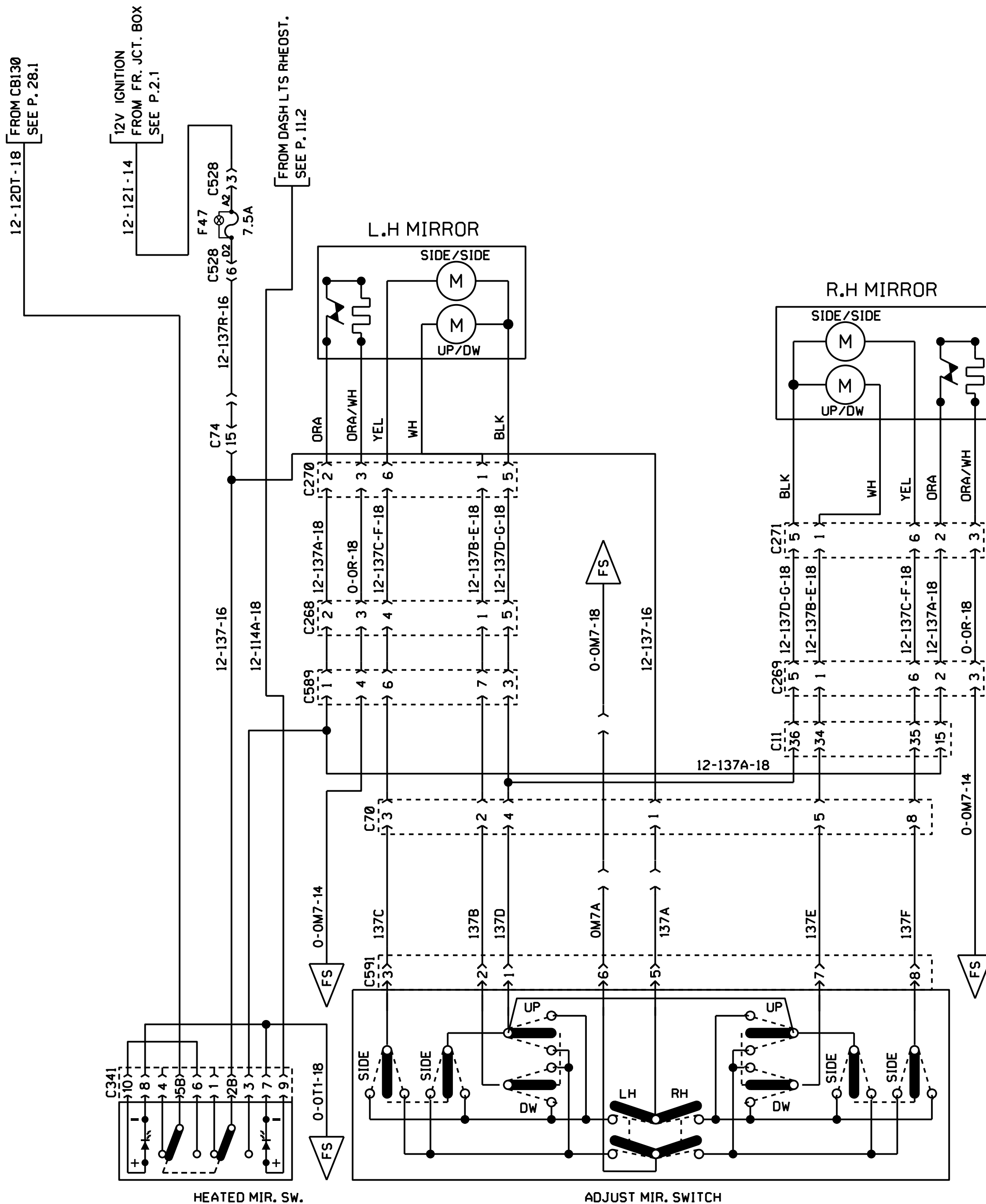

REAR VIEW MIRROR RAMCO FLAT - 1 ADJUSTMENT SW. & 1 HEATED SW.



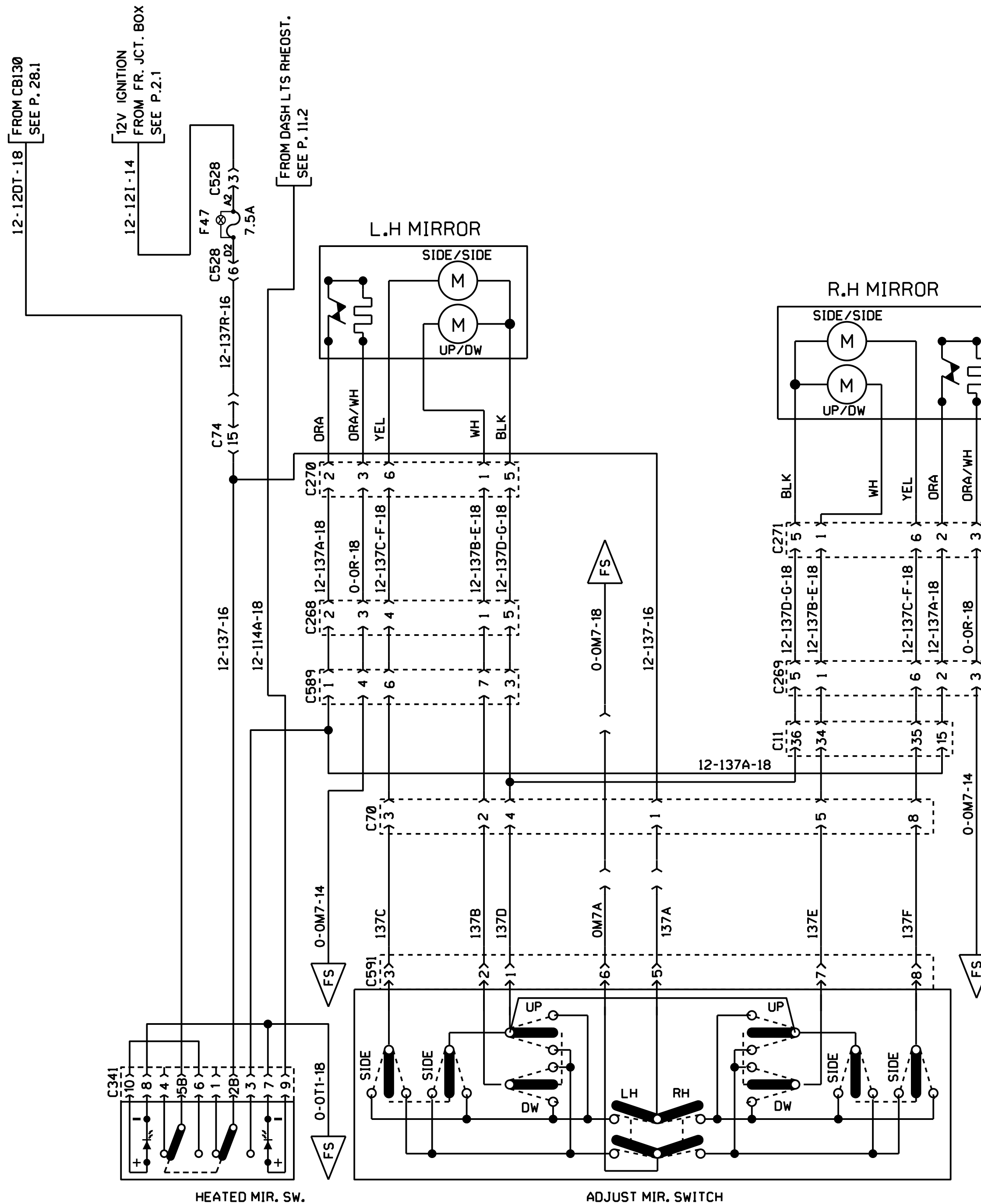

REAR VIEW MIRROR RAMCO FLAT - 1 ADJUSTMENT SW. & 1 HEATED SW.

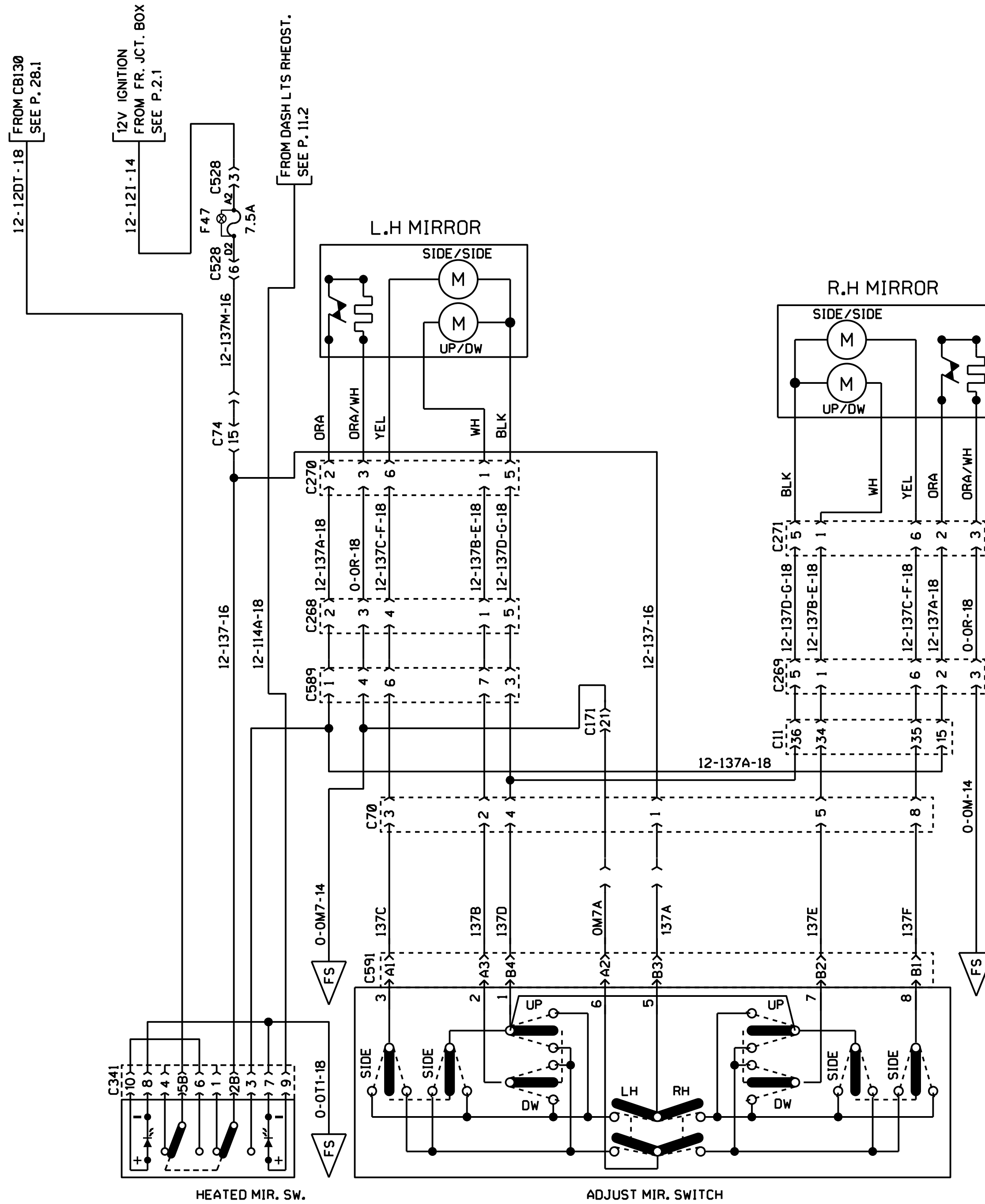

REAR VIEW MIRROR RAMCO FLAT - 1 ADJUSTMENT SW. & 1 HEATED SW.

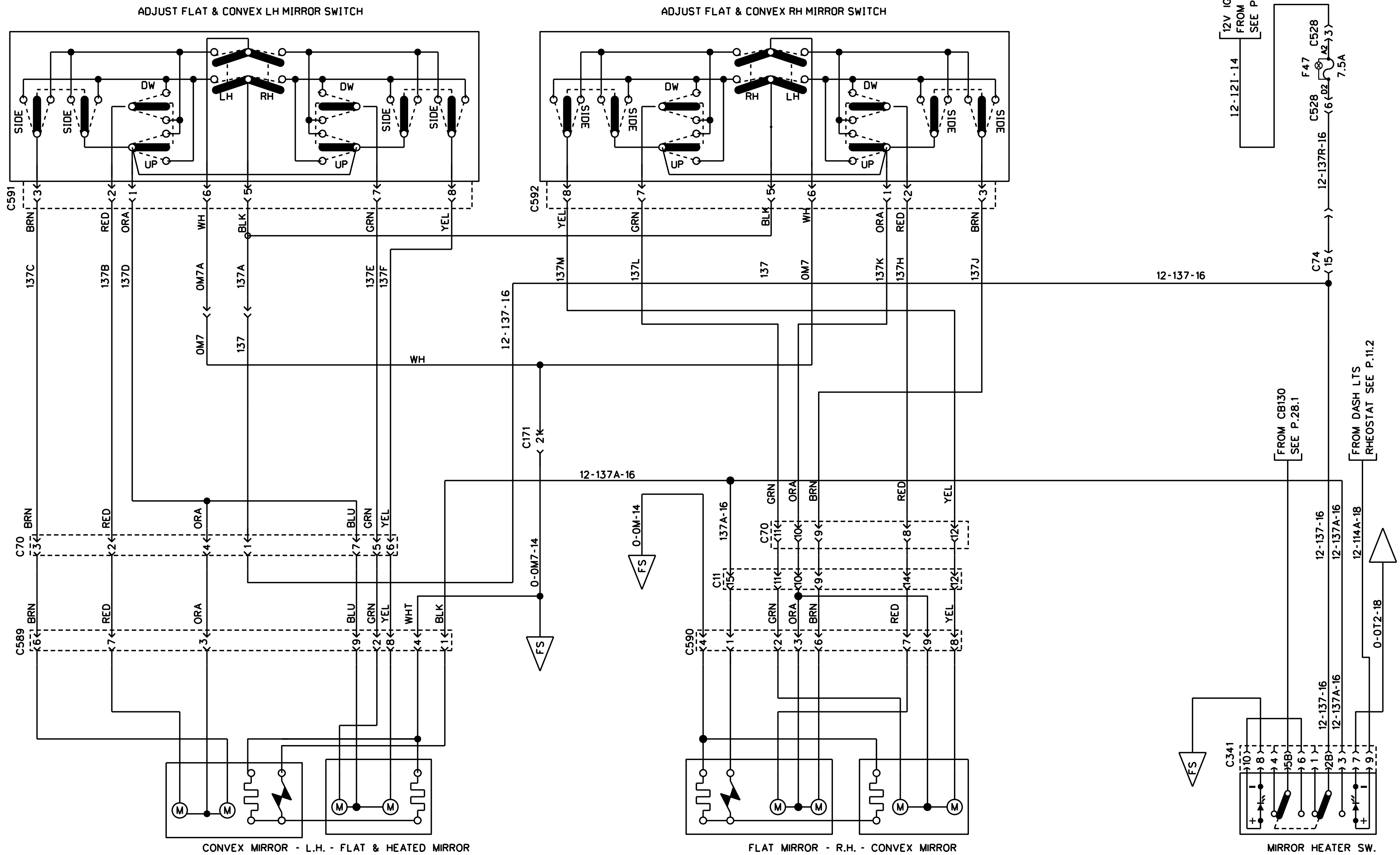

REAR VIEW MIRROR RAMCO FLAT & CONVEX - 2 ADJUSTMENT SW. & 1 HEATED SW.

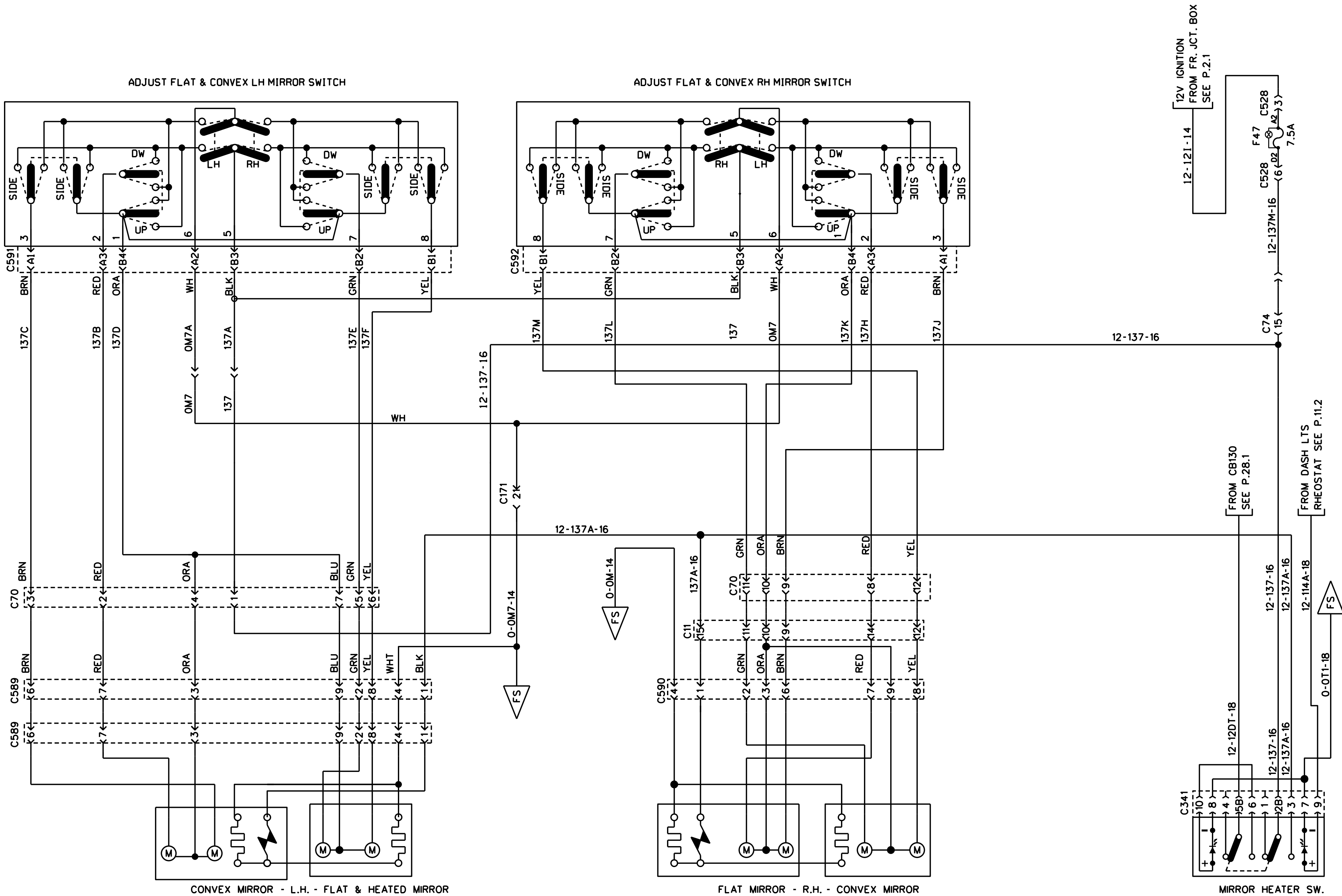

REAR VIEW MIRROR RAMCO FLAT & CONVEX - 2 ADJUSTMENT SW. & 1 HEATED SW.

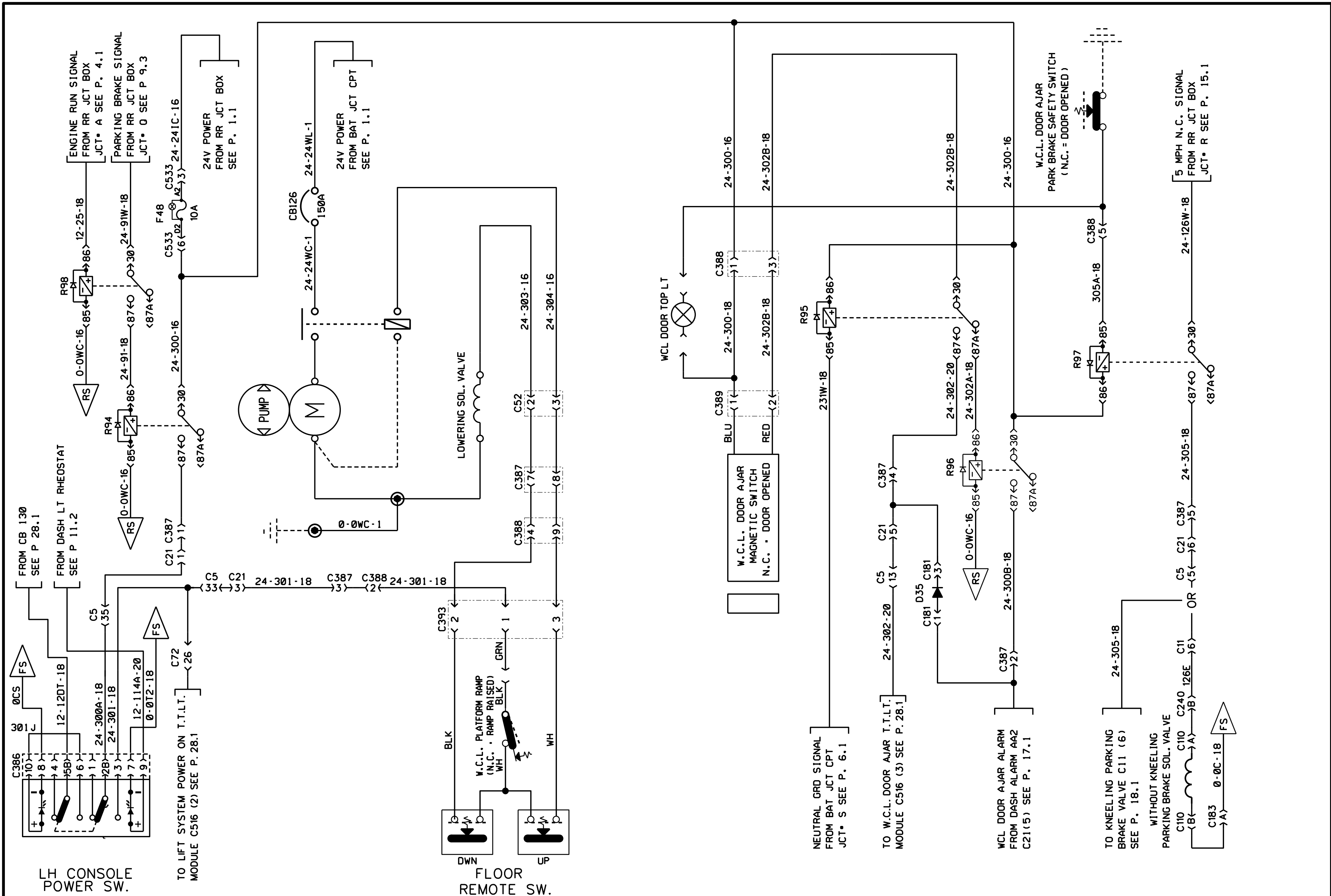

W.C.L. SYSTEM STEWART & STEVENSON

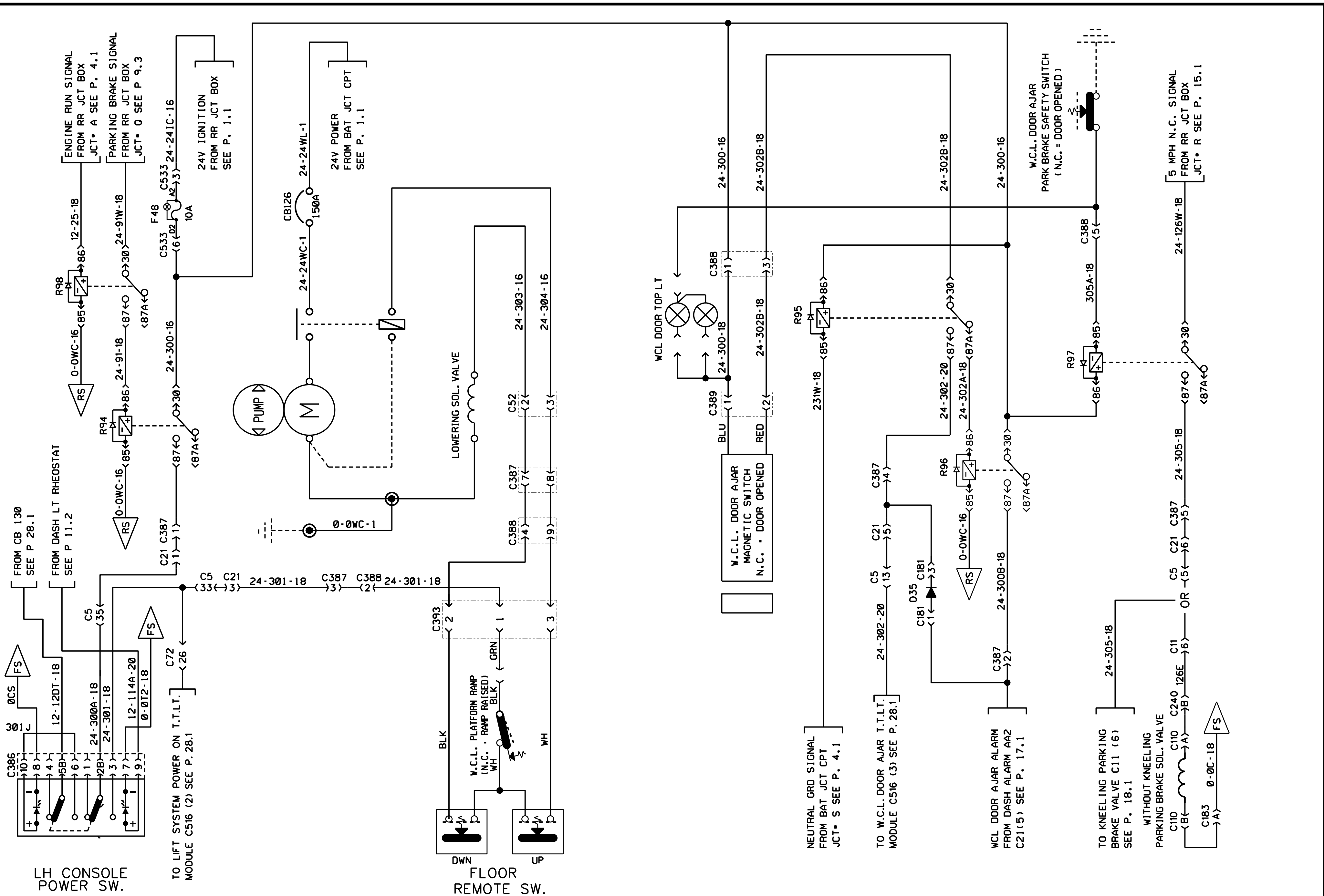

W.C.L. SYSTEM STEWART & STEVENSON

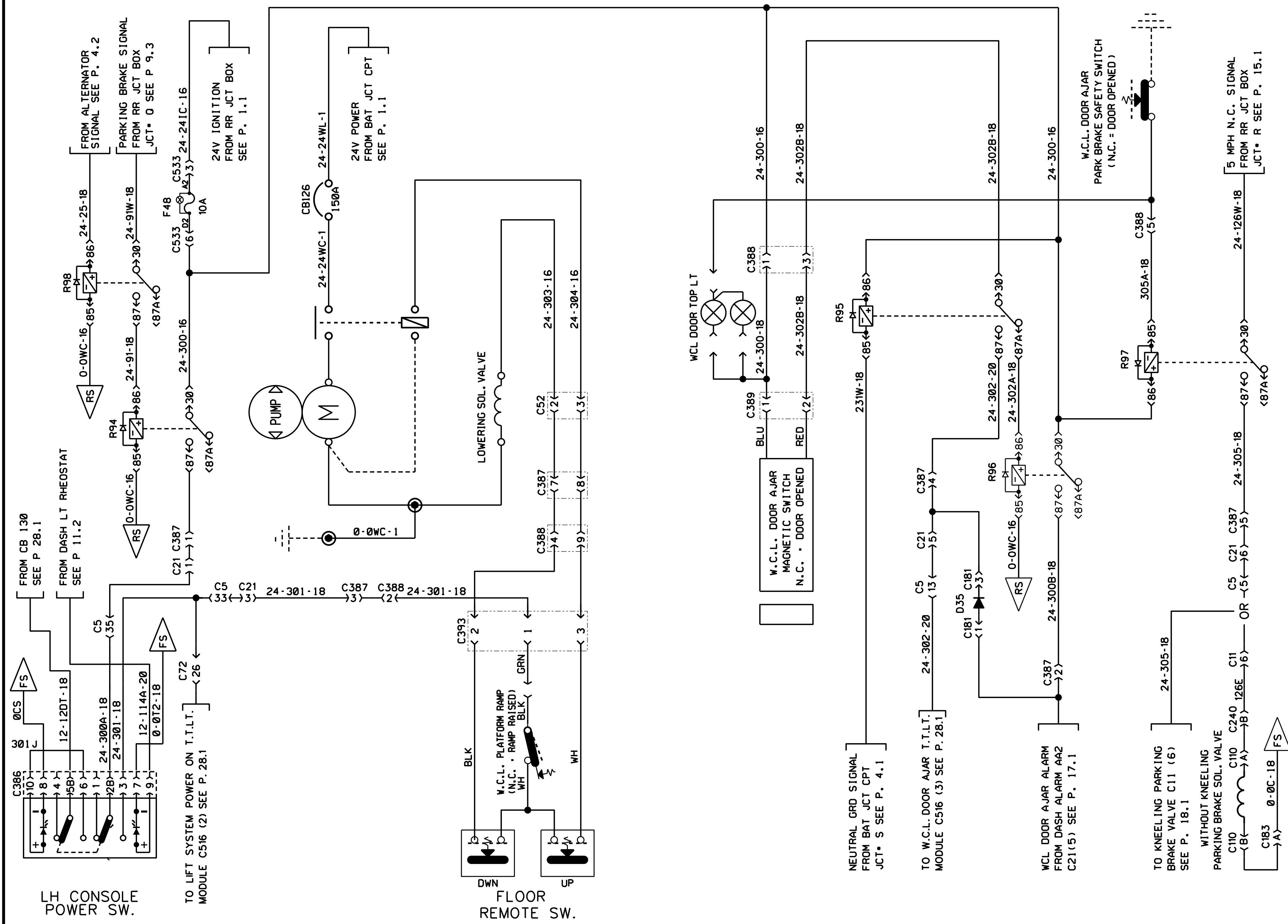

W.C.L. SYSTEM STEWART & STEVENSON

LH CONSOLE  
POWER SW.

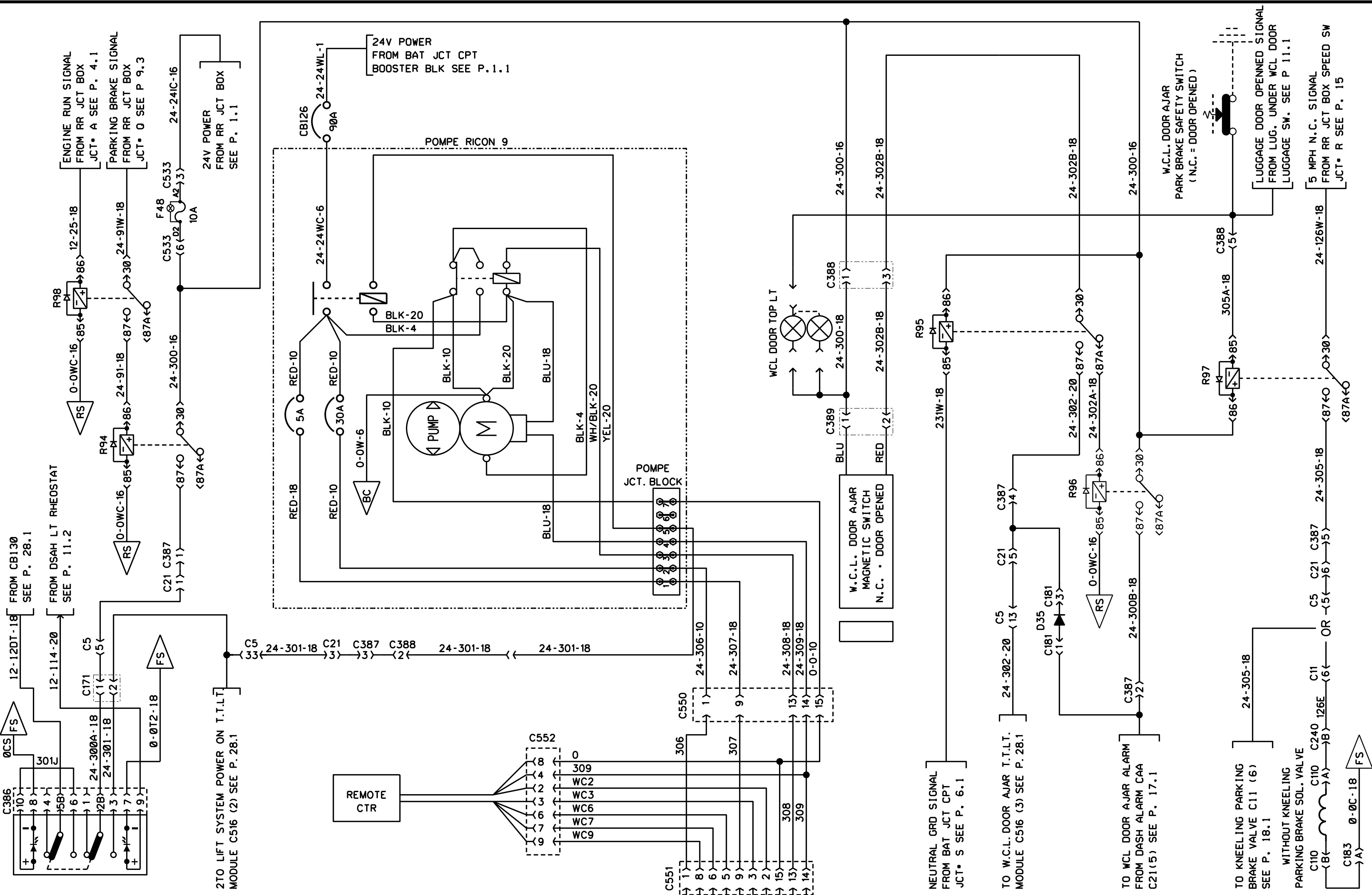

W.C.L. SYSTEM RICON 9



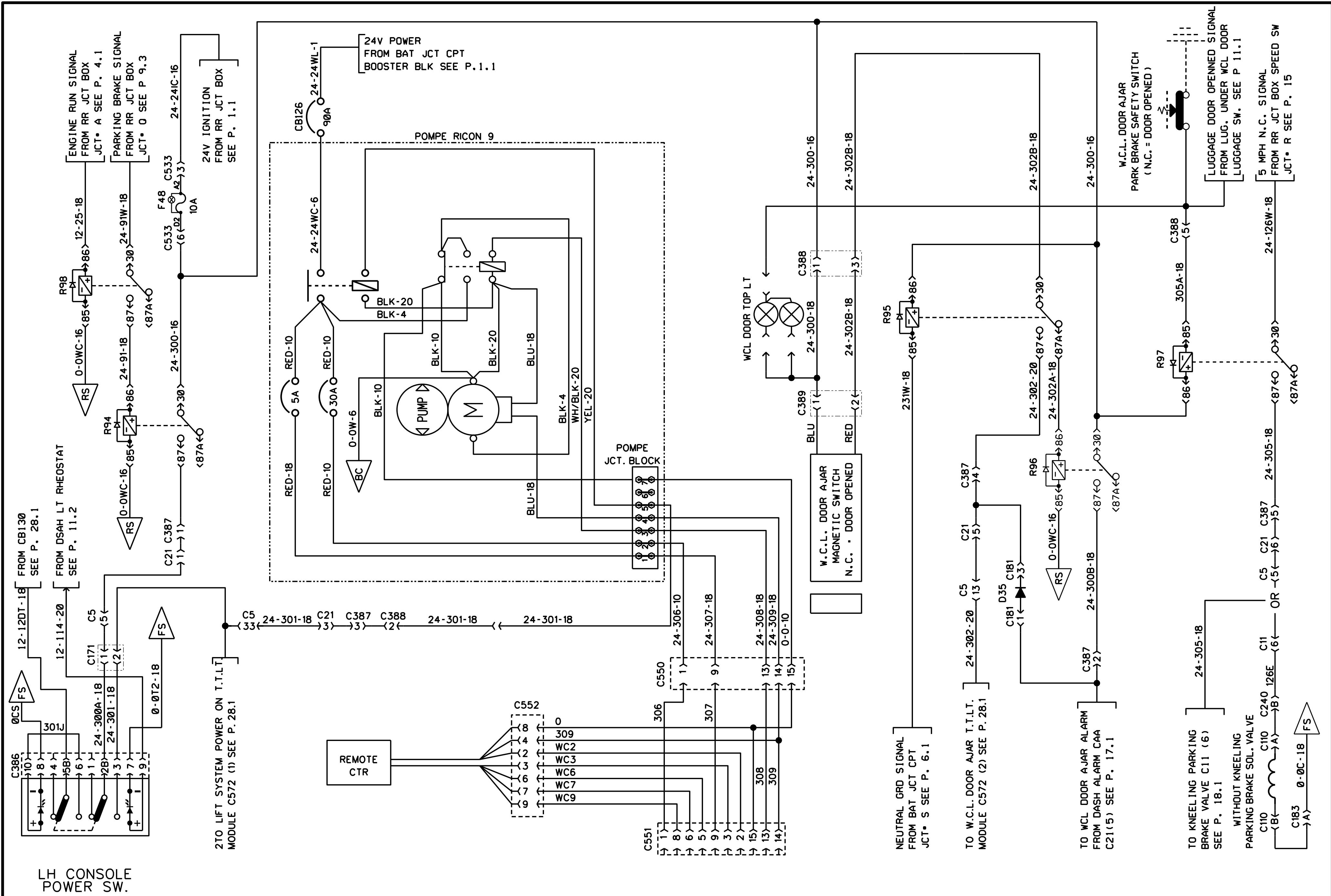

W.C.L. SYSTEM RICON 9

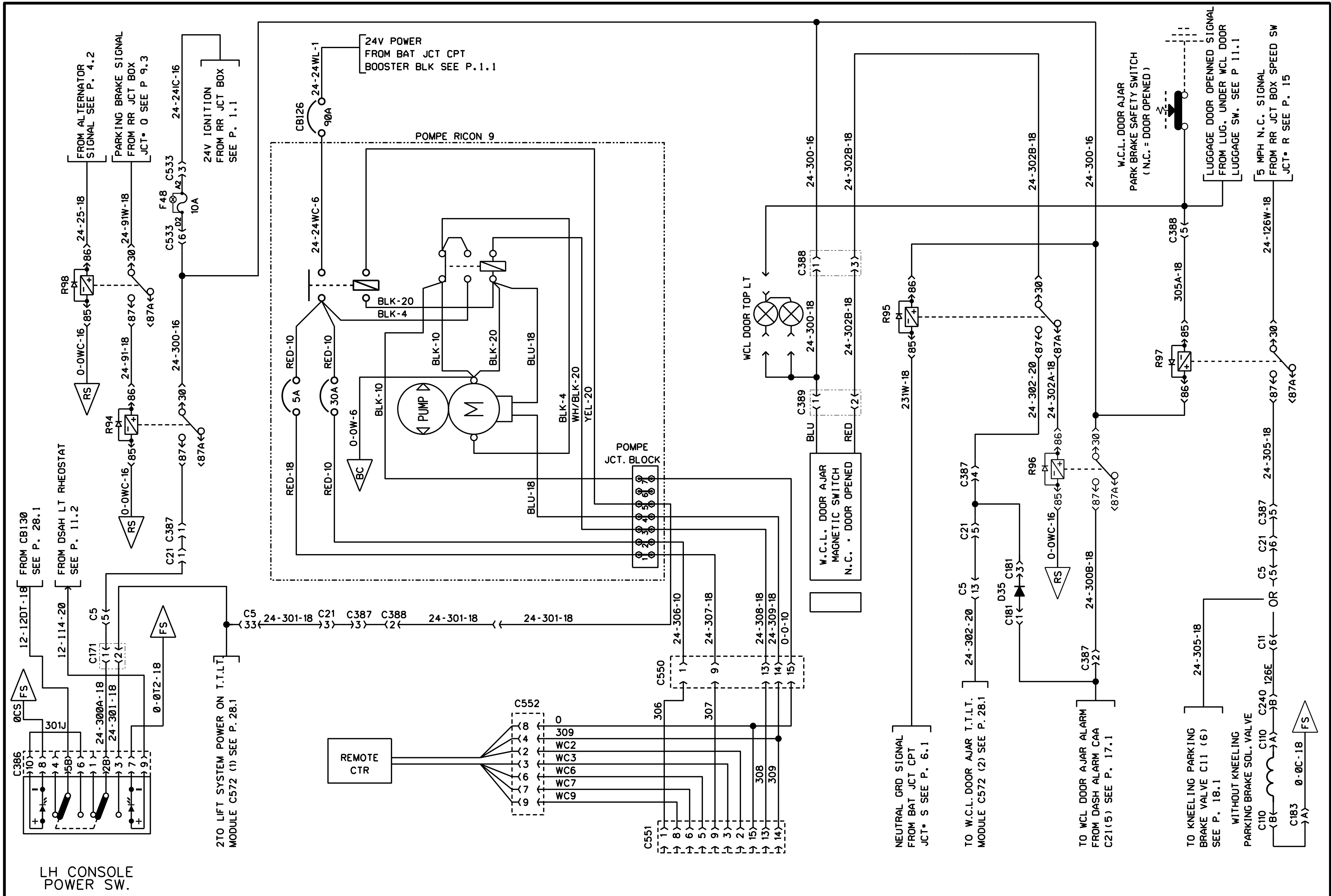

W.C.L. SYSTEM RICON 9

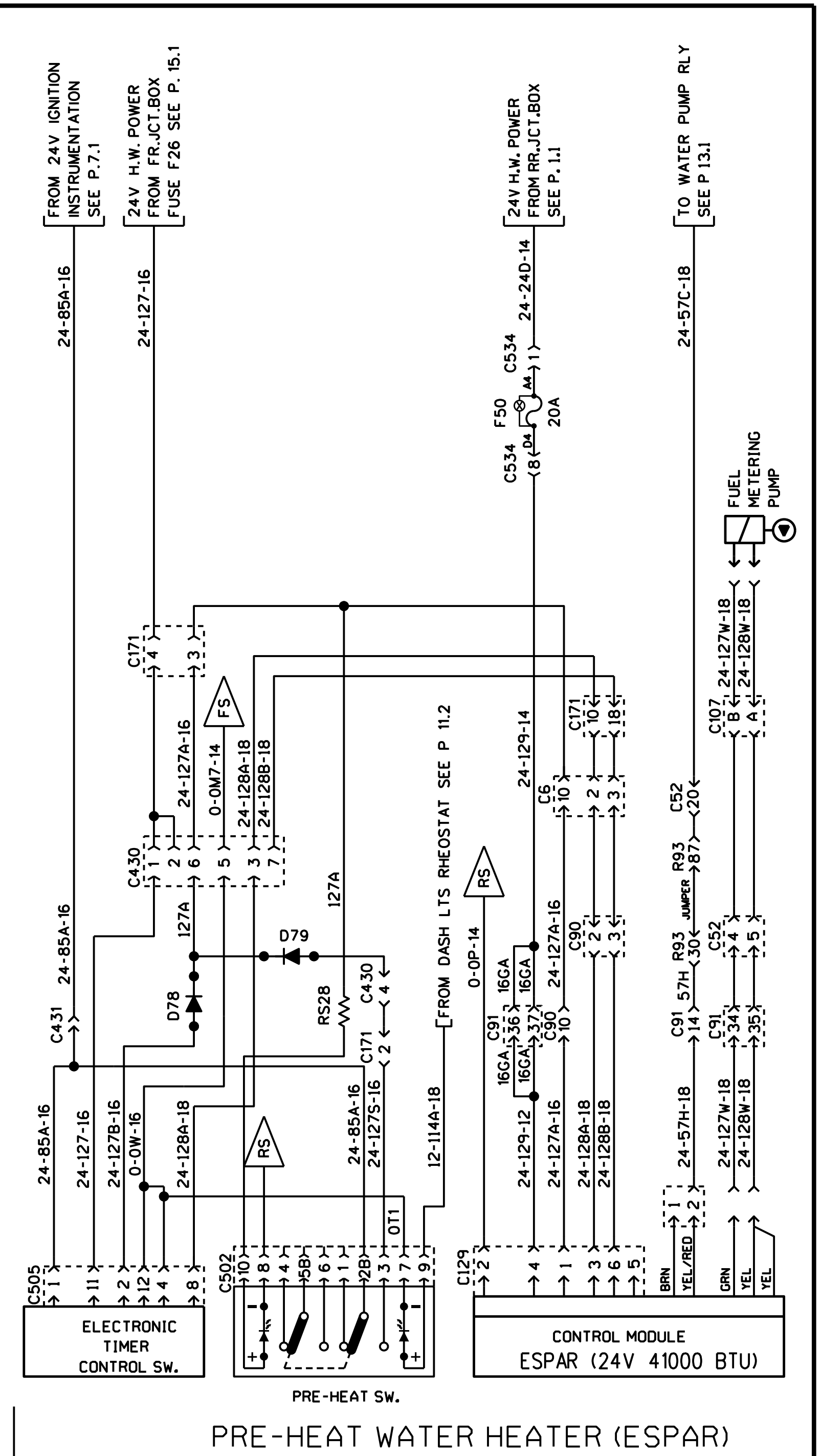
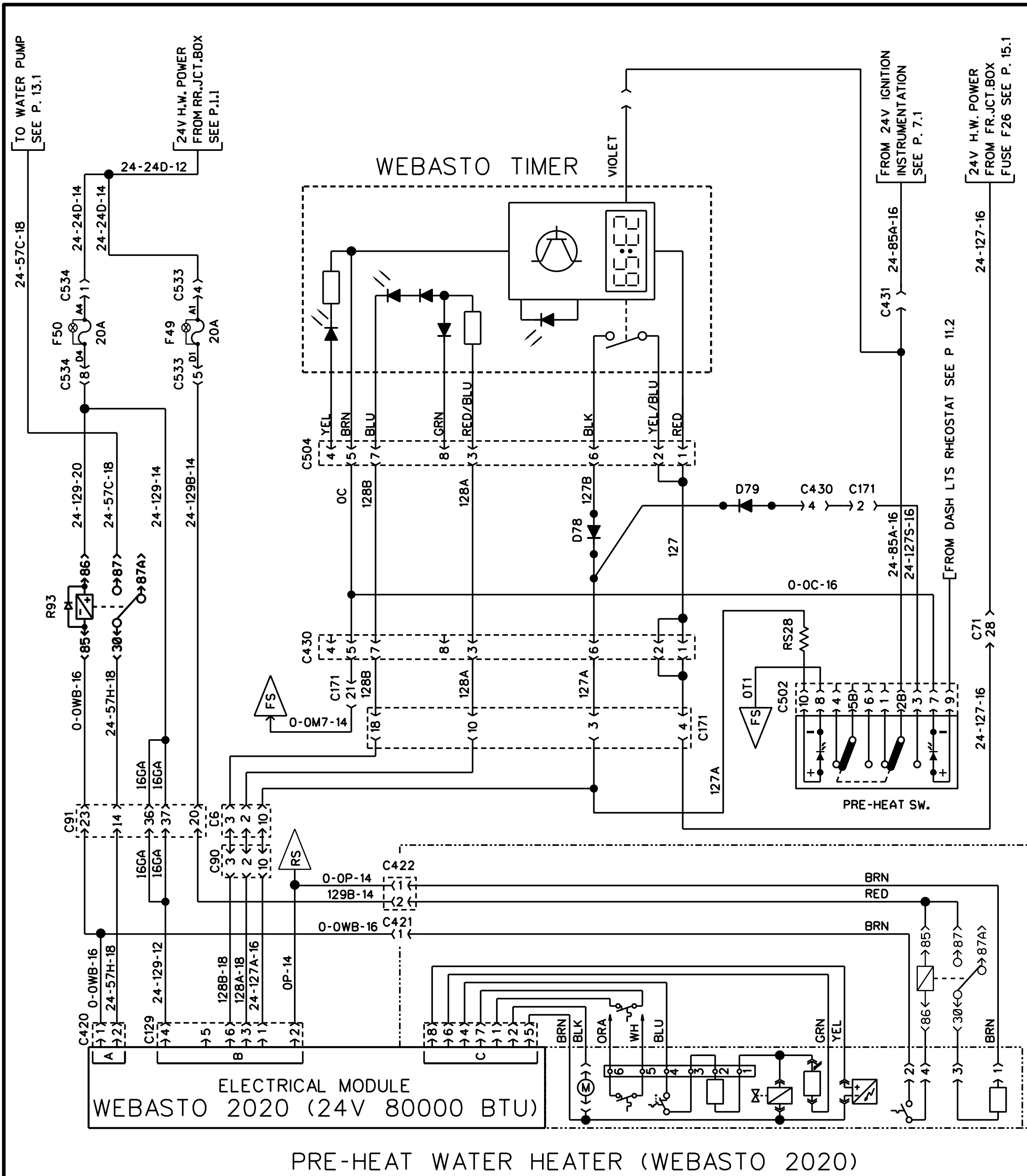

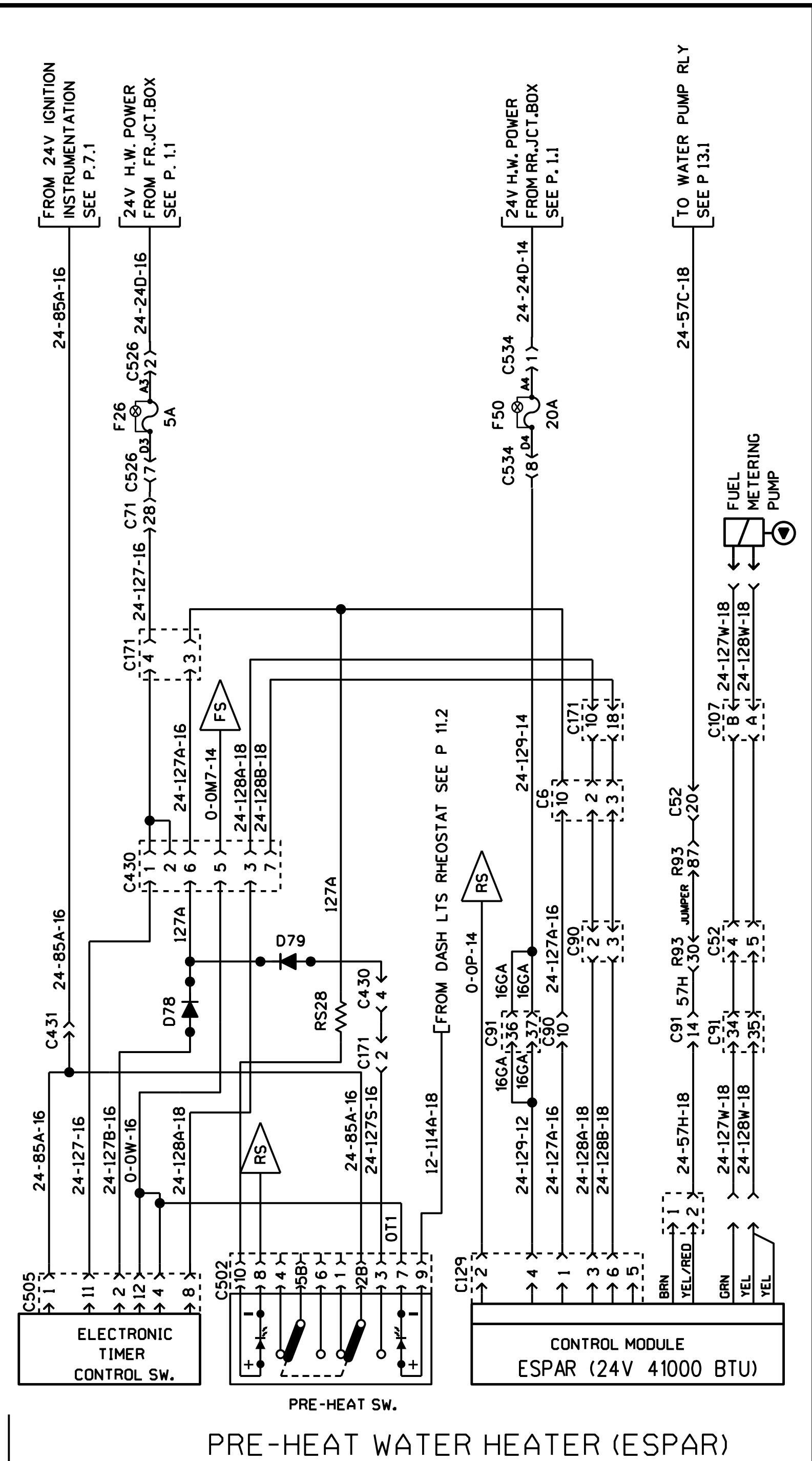
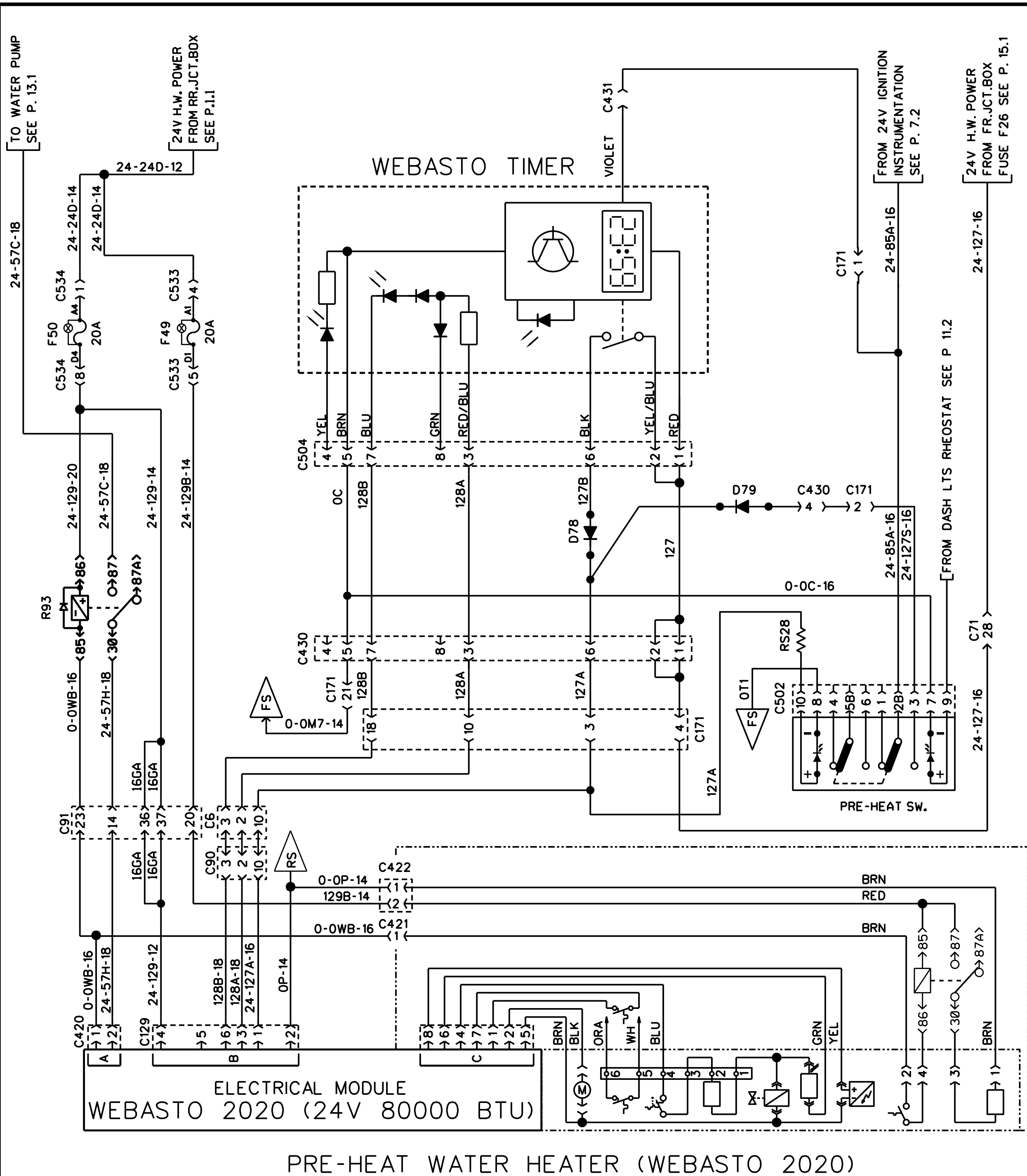

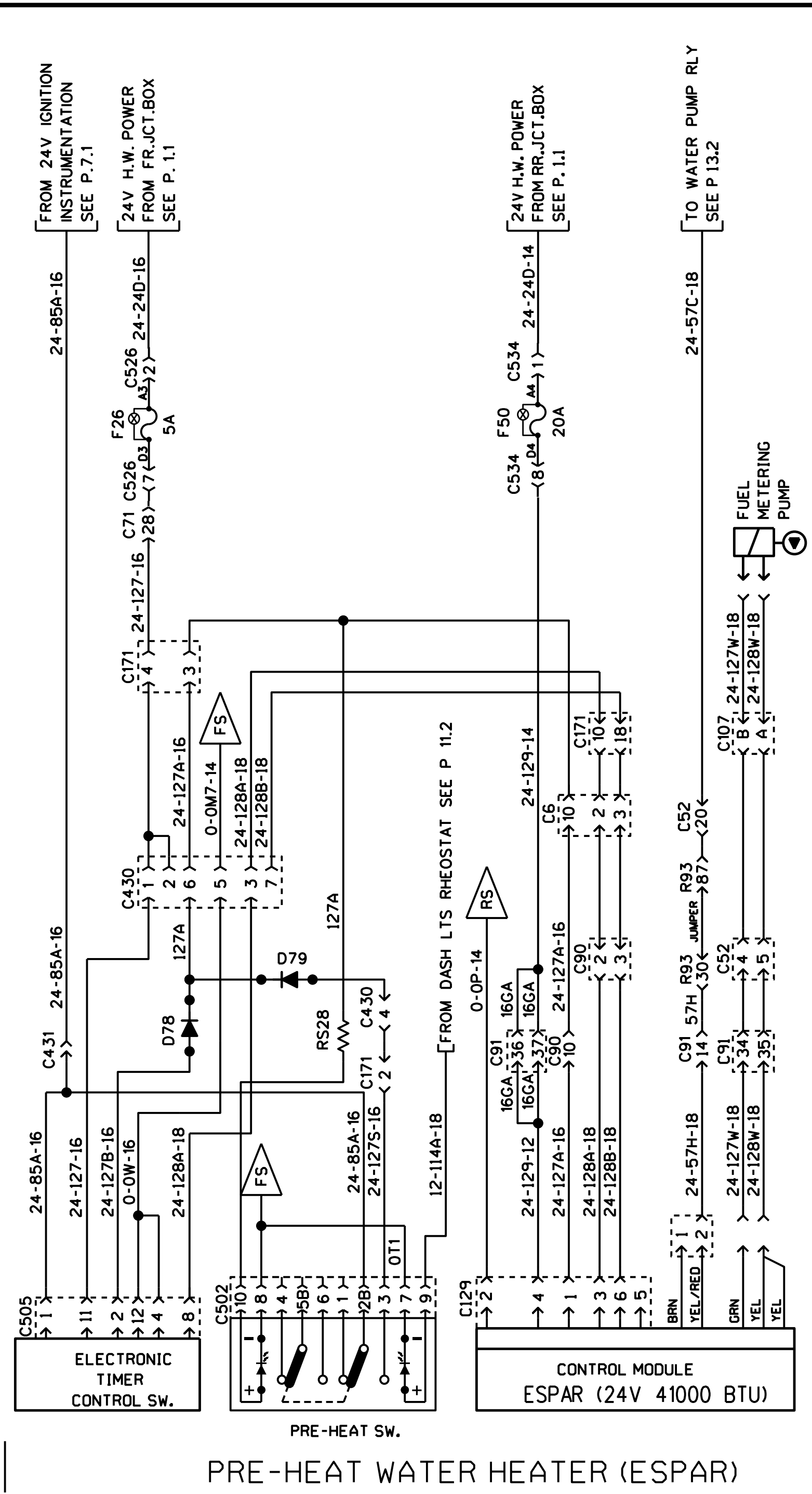
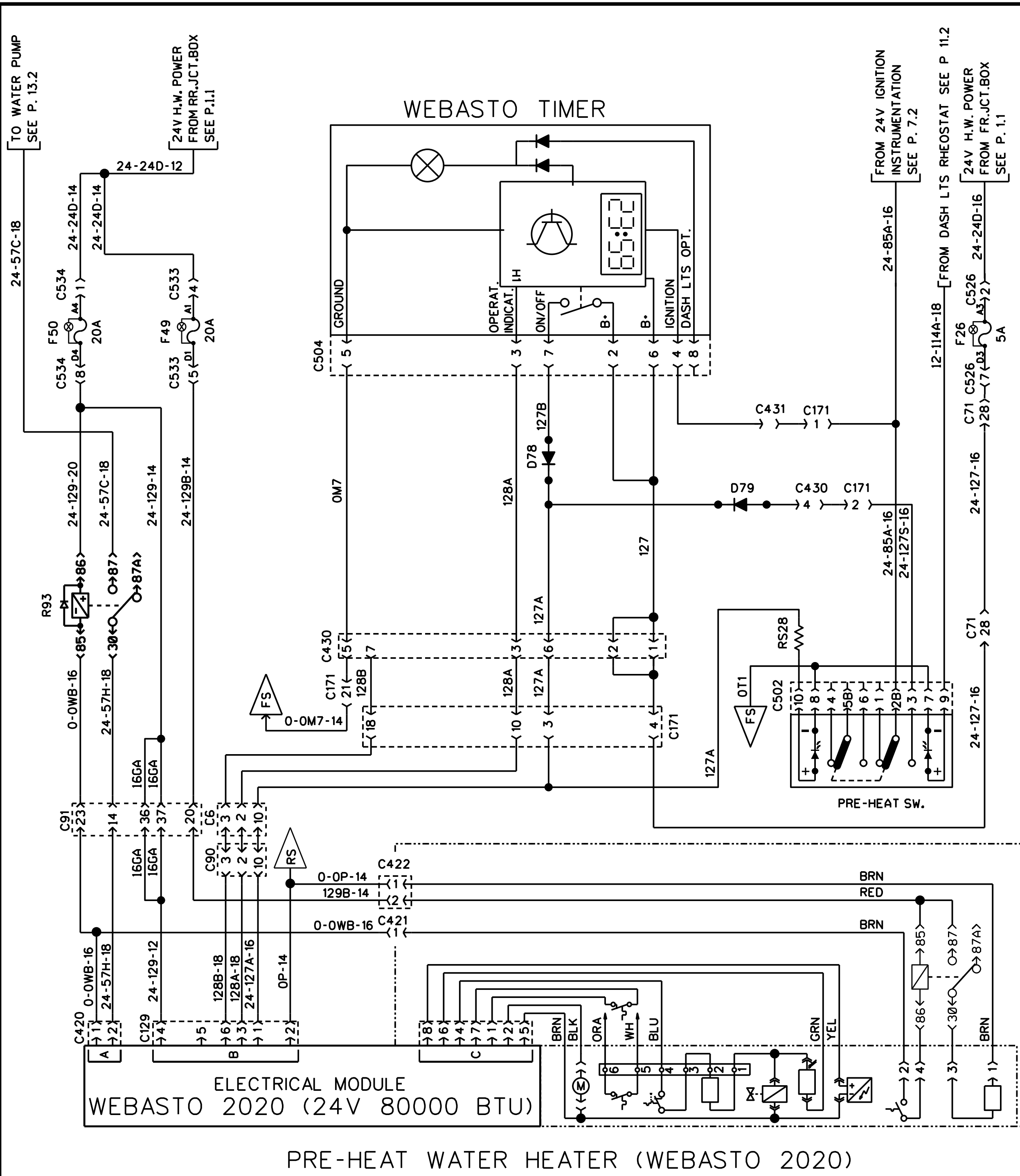

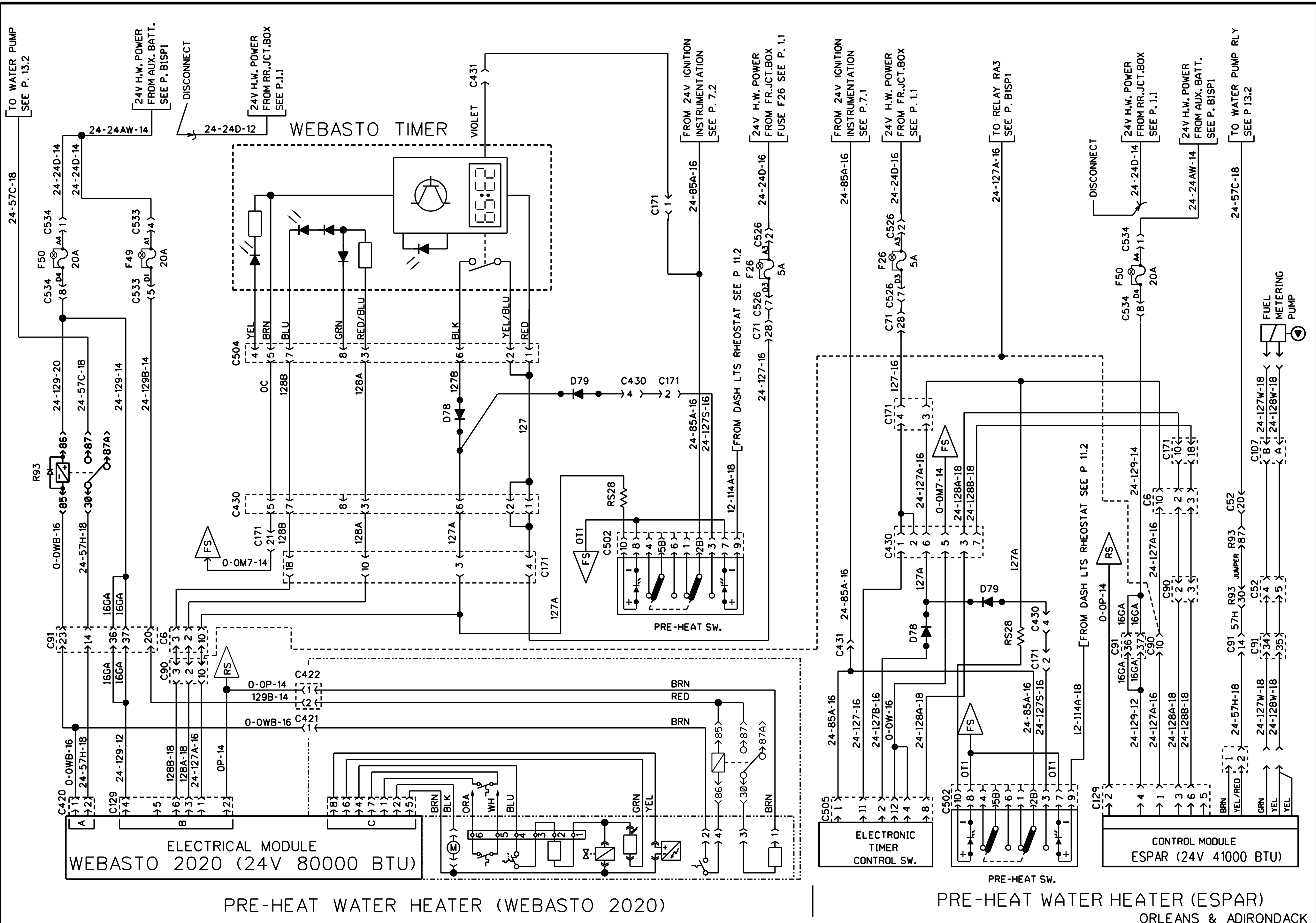

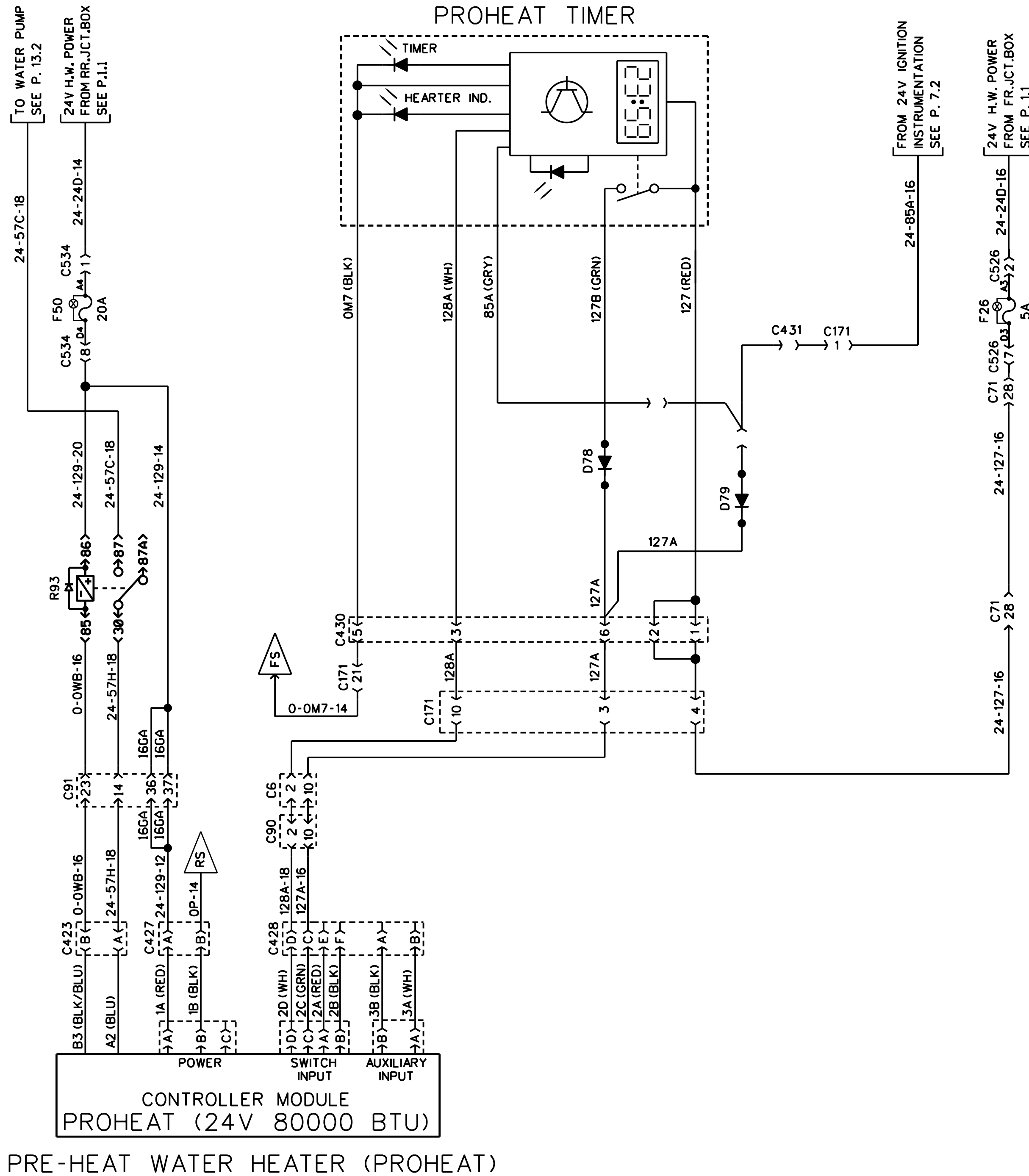

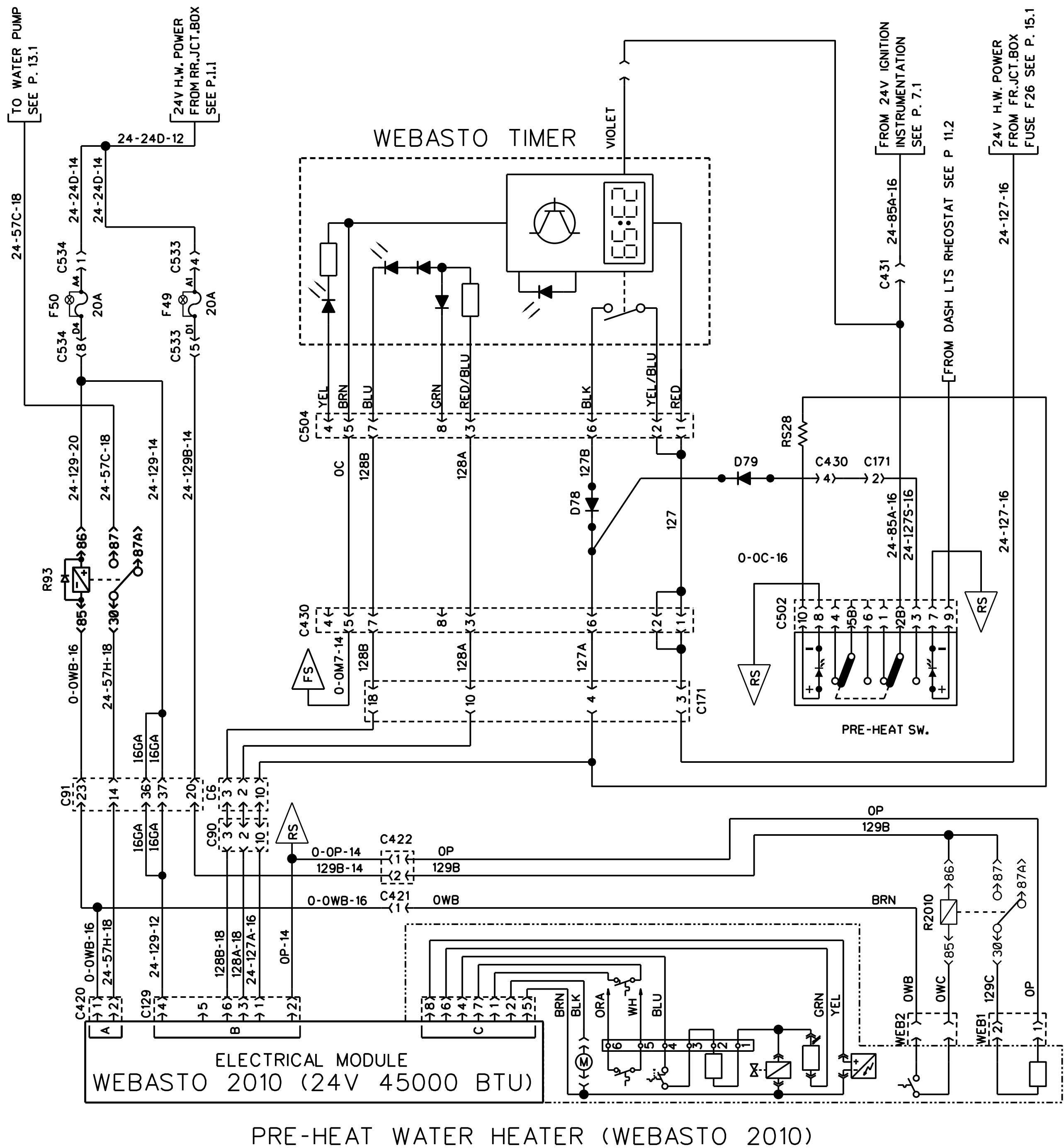

PRE-HEAT WATER HEATER (WEBASTO 2010)



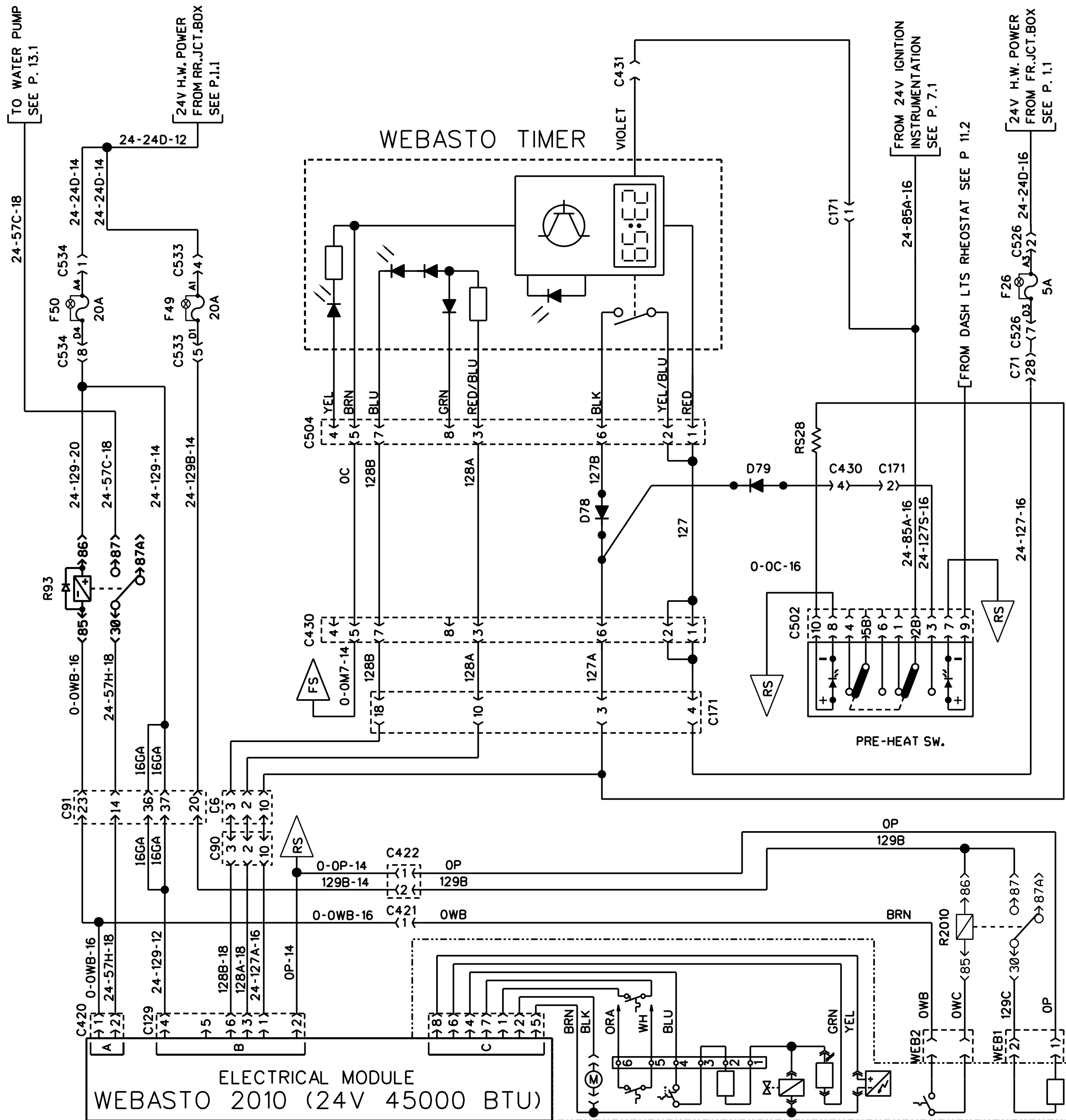

PRE-HEAT WATER HEATER (WEBASTO 2010)

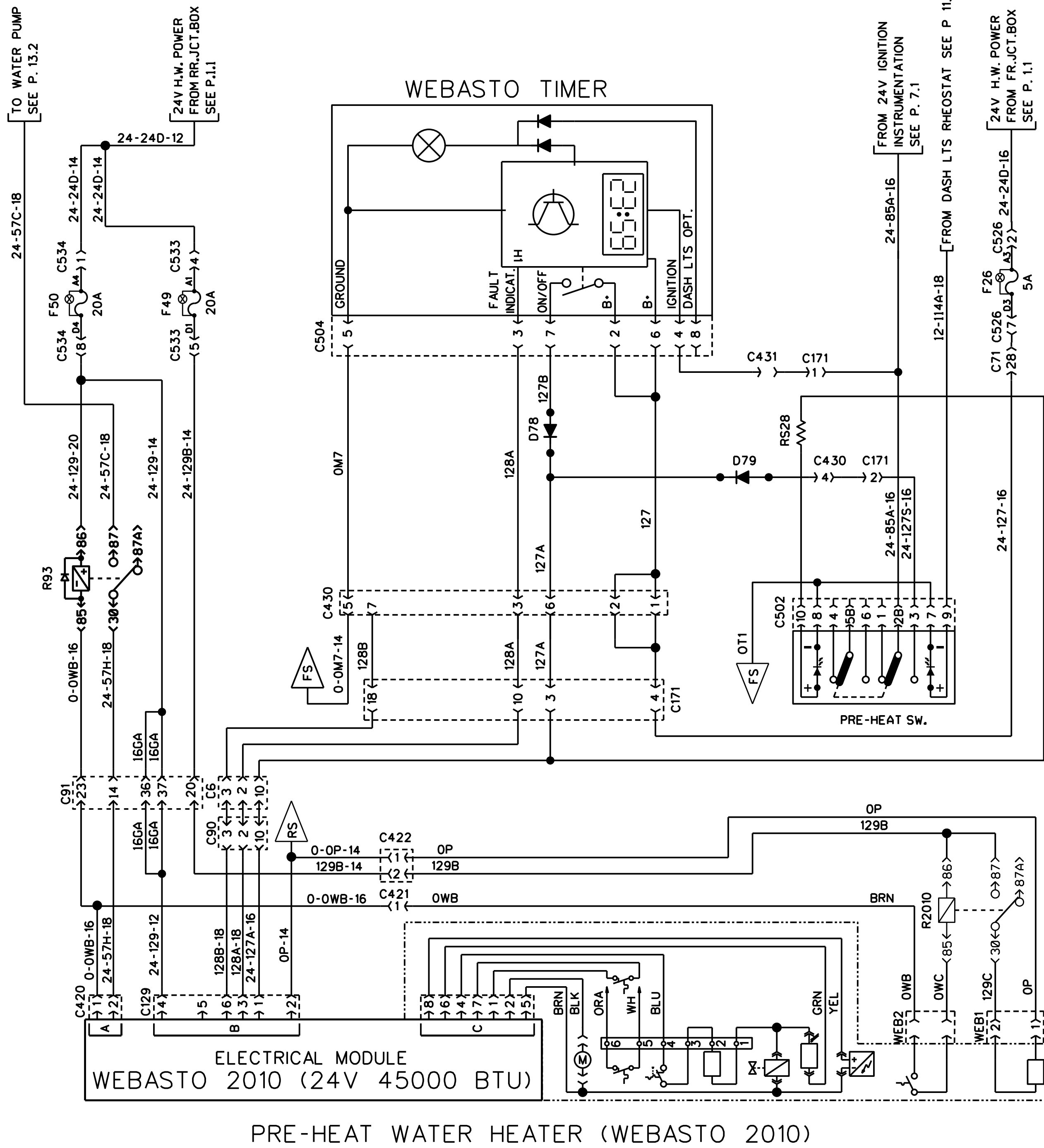

PRE-HEAT WATER HEATER (WEBASTO 2010)

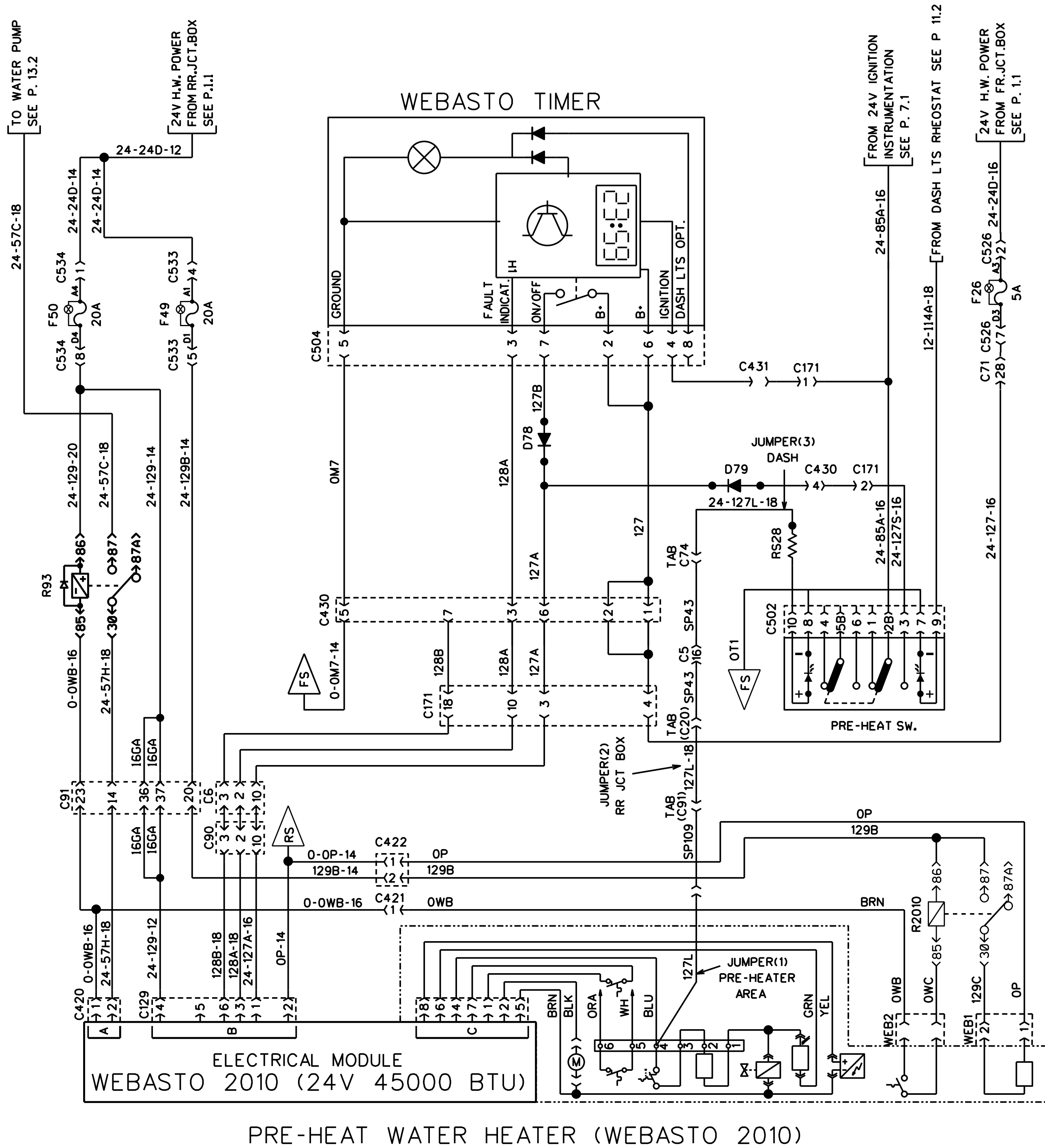

PRE-HEAT WATER HEATER (WEBASTO 2010)

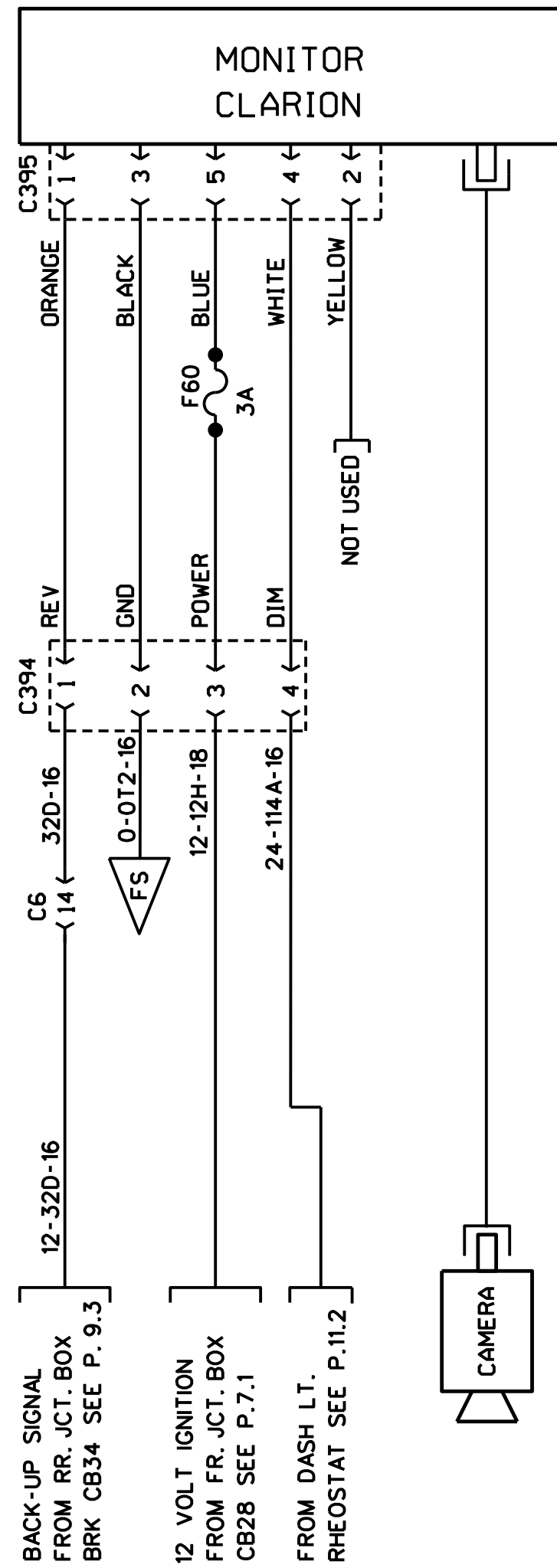

BACK-UP MONITOR (CLARION)

SECONDARY INTERCOM

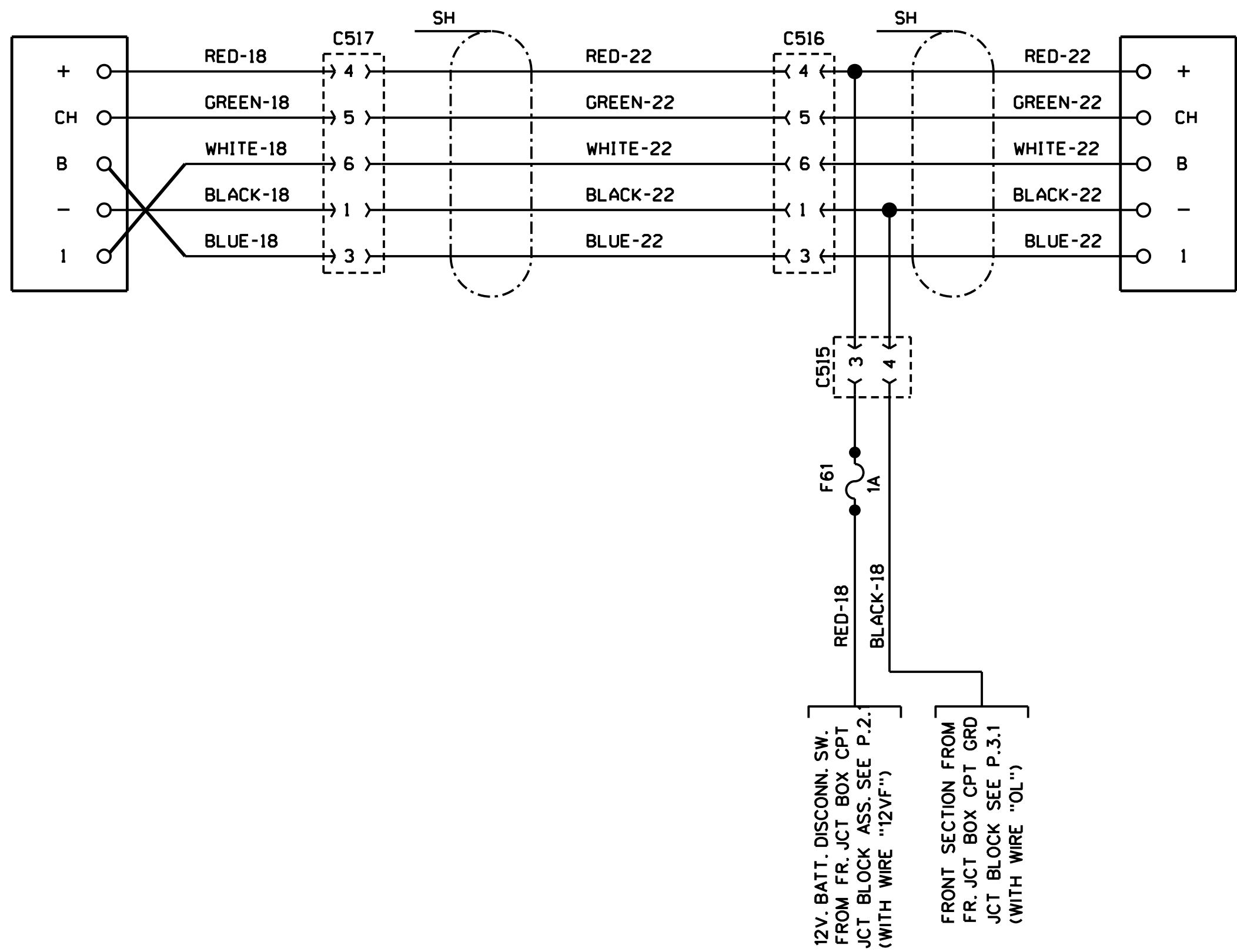

INTERCOM

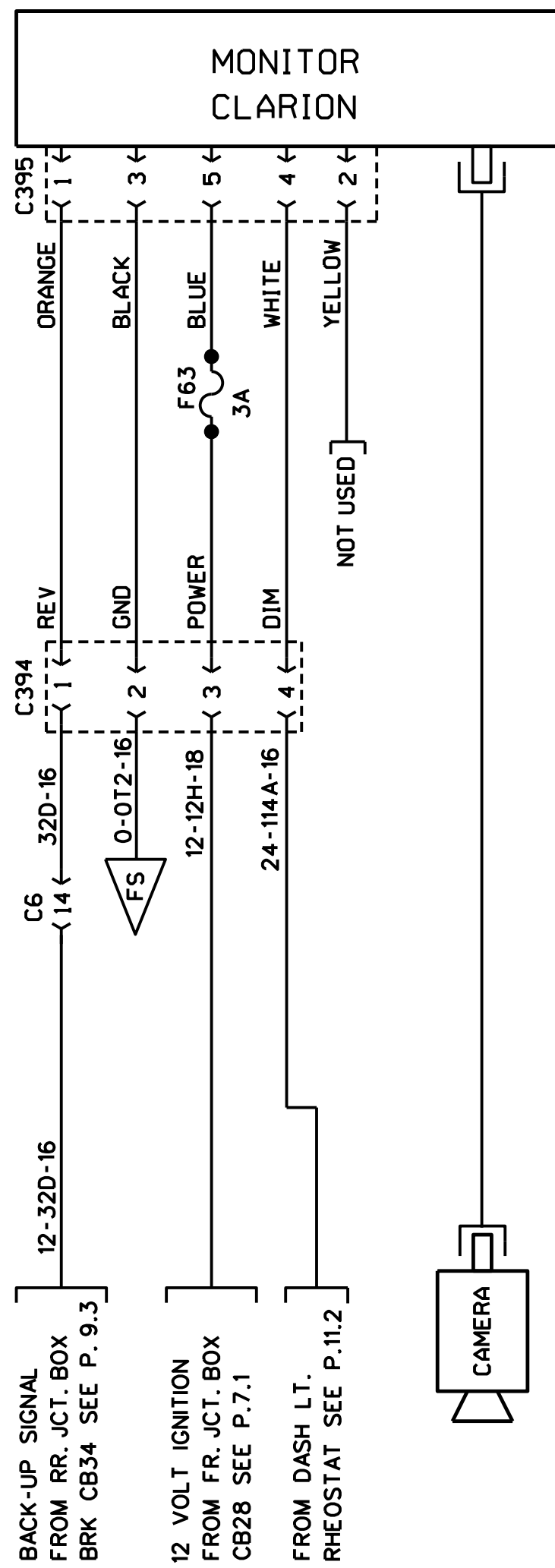

BACK-UP MONITOR (CLARION)

SECONDARY INTERCOM

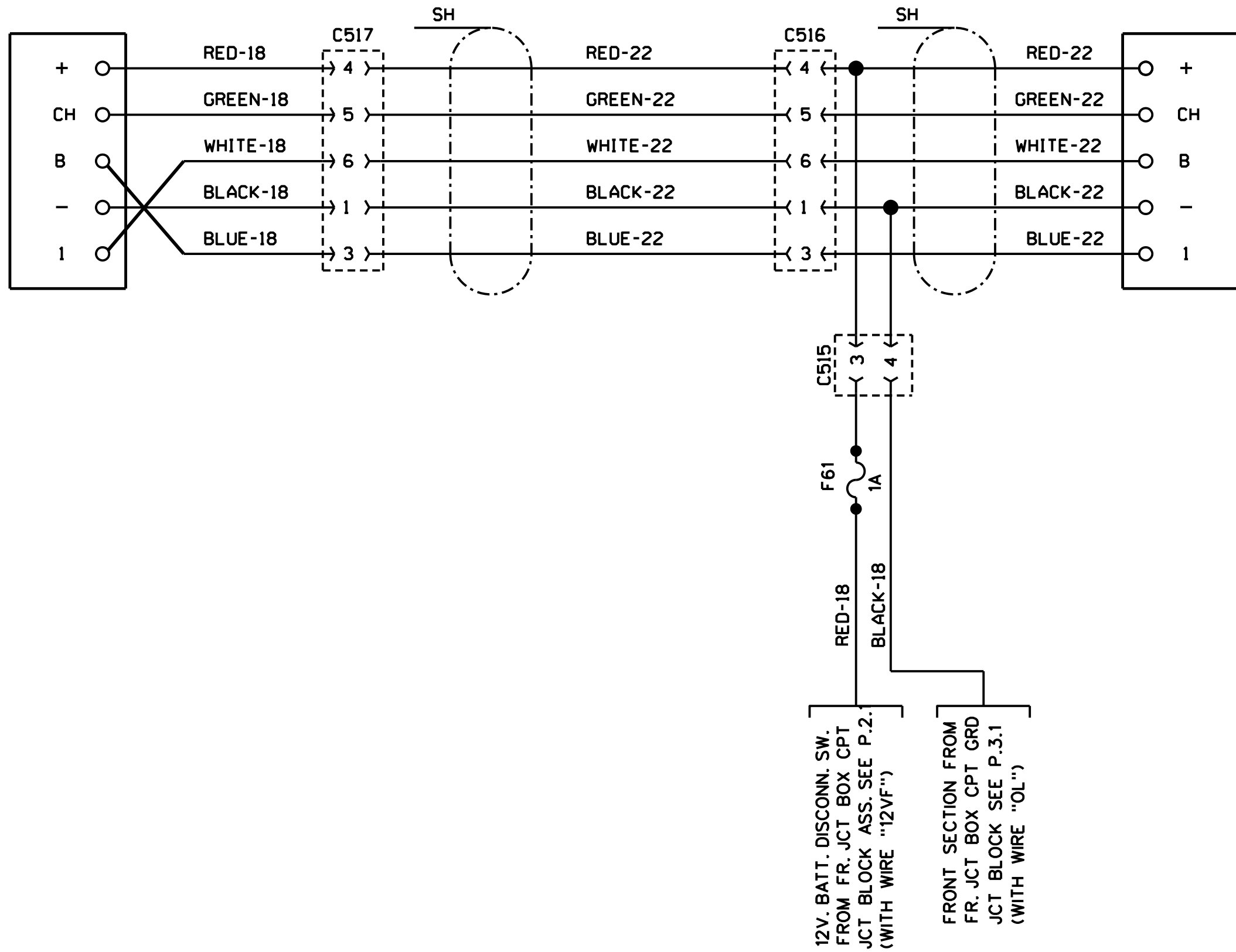

INTERCOM

REMOTE TEST SW.

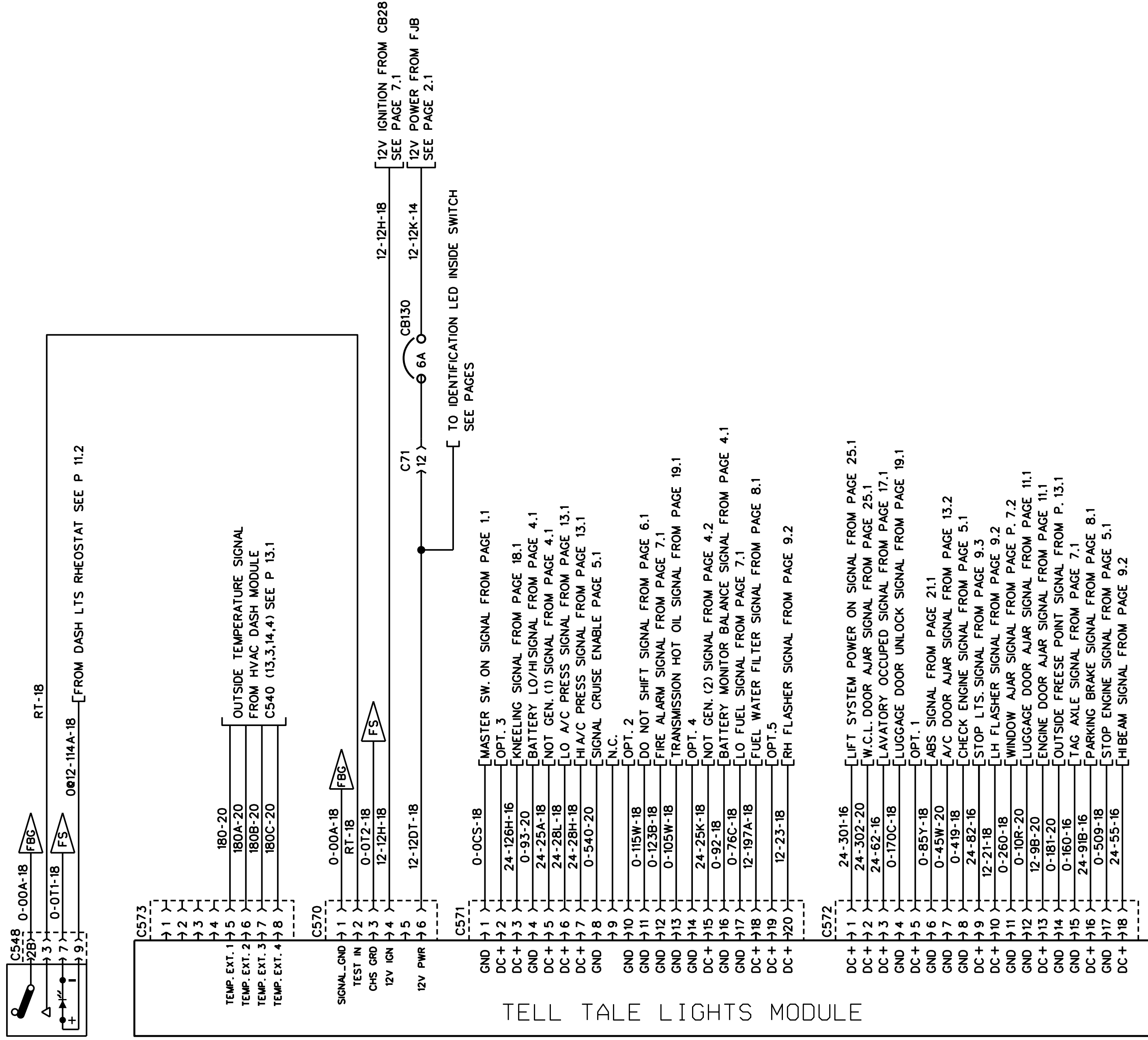

TELL TALE LIGHT MODULES

TELL TALE LIGHTS MODULE

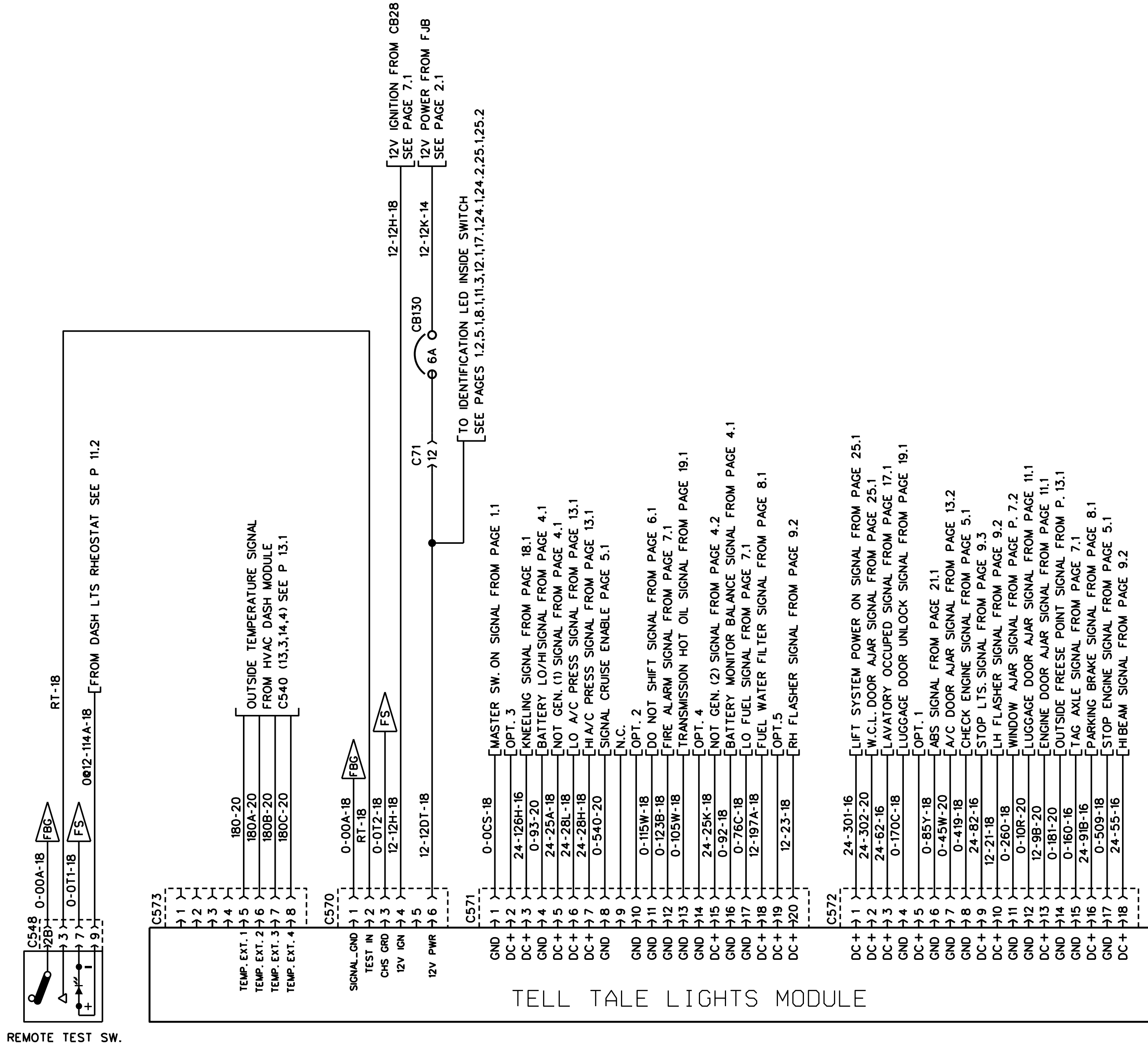

TELL TALE LIGHT MODULES

REMOTE TEST SW.

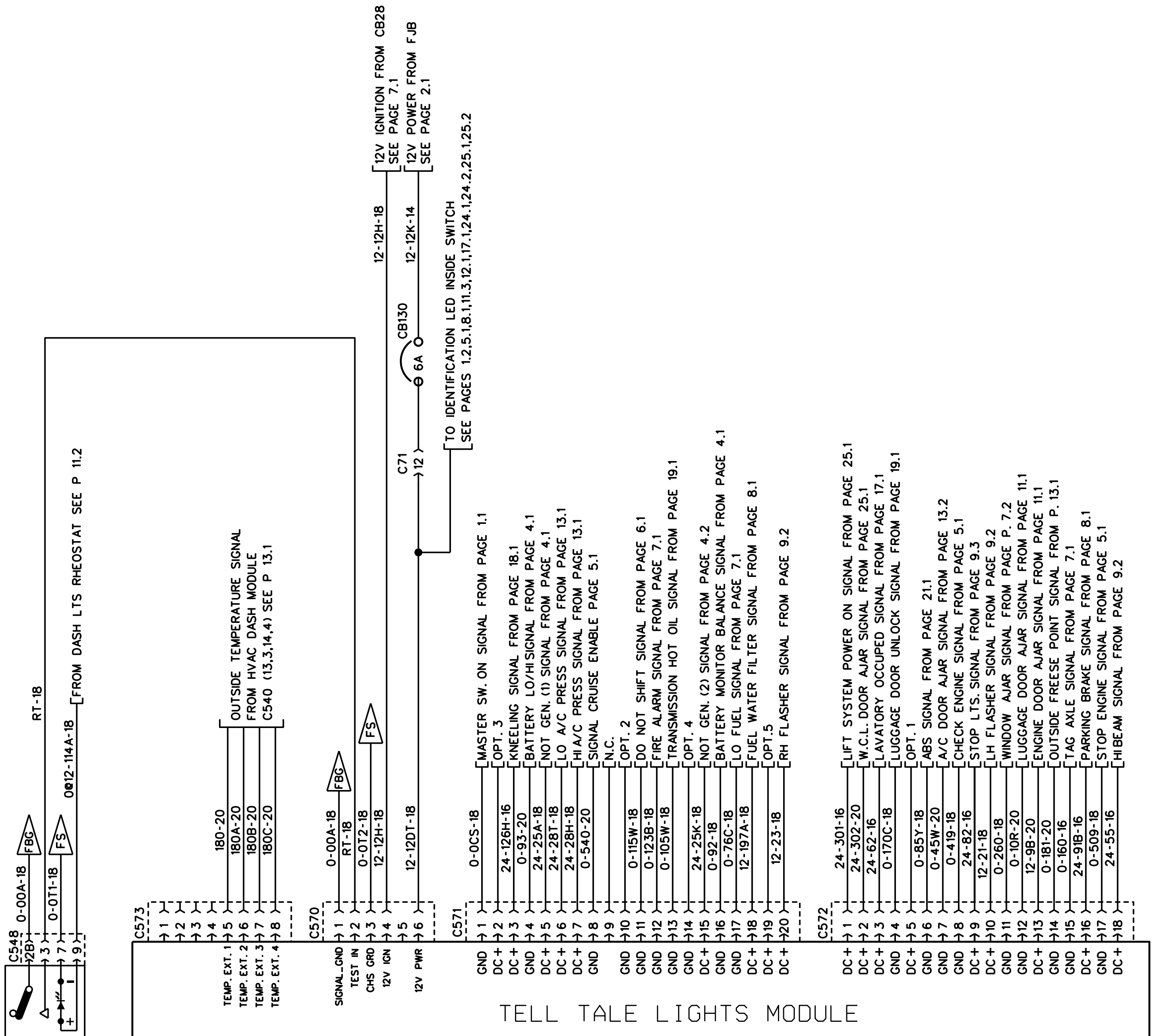

TELL TALE LIGHT MODULES



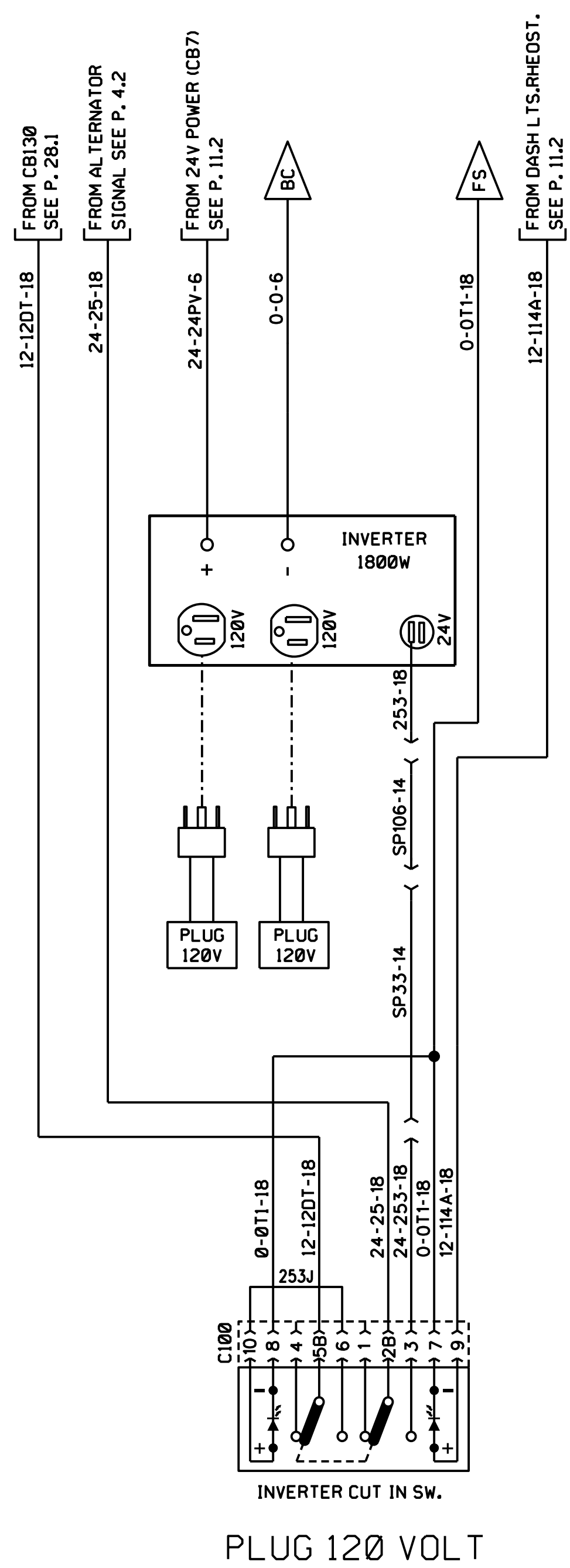

LOAD FAN (MAX.)  
 2 MOTEUR-12 AMP. TOTAL  
 4 MOTEUR-24 AMP. TOTAL

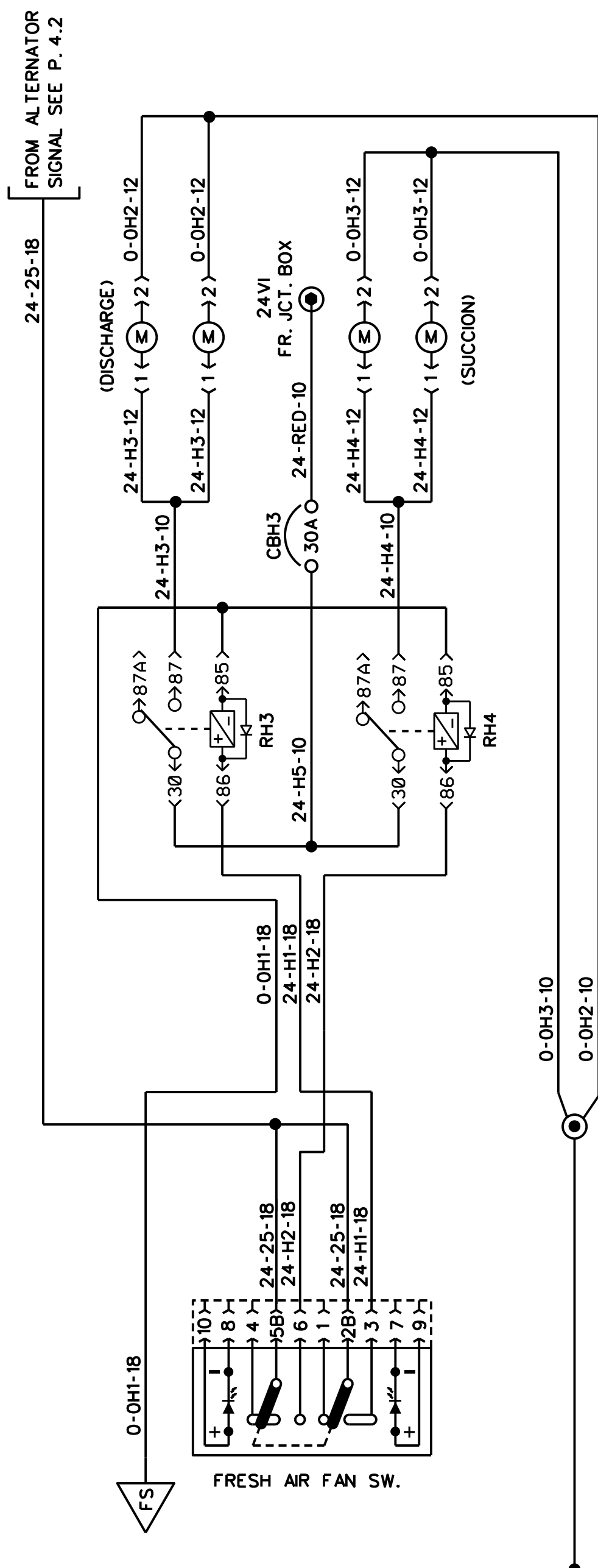

CHASSIS GROUND

CHASSIS GROUND

FRESH AIR FAN SW.

X3298 (LIMOCAR)