

# COMMUTER

REV.	DATE	O.C.	EFF.	DESCRIPTION	PAGE(S)	BY	CHECKED	APPROVED
0	2018-01-16	2017111	7513	NAE COM NYSDOT	ALL	S.B.	C.Lem.	C.Lem.
1	2018-05-15	2017111	7513	UPDATE	1.1,3.2,5.1,5.2,29.1,35.1,35.6 35.7, 38.1, 0	S.B.	C.Lem.	C.Lem.
2	2018-12-04	N/A	7513	PAGE UPDATED	0, 18.1	S.B.	C.Lem.	C.Lem.
3	2019/11/29	2018165	7721	NYCTA3	0,1.1,2.1,2.2,3.1,3.2,4.1,4.2, 5.1,5.2,6.2,7.1,8.1,10.1,12.1 12.2,14.1,14.2,14.3,16.1,16.2, 17.1,18.1,18.2,18.3,18.4,19.1 20.1,21.1,22.2,23.1,25.1,26.1, 26.2,26.3,26.4,28.1,29.1,30.1, 31.1,32.1,35.2,35.3,35.4,35.7, 35.8,35.9,35.10,36.1,37.1, 38.2,40.2,42.1,43.1,G,C1.2 F,H,J,K,L	SB GP C.Lrv.	G.P	GP
4	2020/08	2018165	7768	UPDATE	0,1.1,2.1,2.2,3.1,3.2,4.1,4.2, 5.1,5.2,6.2,9.1,16.2,17.1,18.3, 23.1,28.1,29.1,32.4,35.1,35.3 35.4,35.7,35.8,36.1,37.1,38.2, 40.2,43.1,A,G,H,J,K	S.B.	G.P	G.P
5	2021/01	2018165	7751	Cradle Point WIFI Battery charger Removed (17.1 end)	0.35.4 3.1,2.2,2.1	SC SB	GP	GP
6	2021/01/19		7848	OBD21, UPDATE	0,3.2,4.1,5.1,6.2,12.1,14.1,C1 4.2,G	S.B.	GP	GP

	WIRING DIAGRAM	DWG NO.: D06178PO	REV 10
--	----------------	-------------------	--------

# COMMUTER

REV.	DATE	O.C.	EFF.	DESCRIPTION	PAGE(S)	BY	CHECKED	APPROVED
7	2021-02-08	2020085	7829	ABLE UPDATE	0,35.8,5.2,C 42.1, 4.2,28.1,A	S.B.	G.P	G.P
8	2021-03-12	2020085	7829	UPDATE	0,28.1	S.B.	G.P	G.P
9	2021-04-15	2018085	7829	UPDATE	0,35.7	S.B.	G.P	G.P
10	2021/11/26	2022001	8008	OBD22 UPDATE	0,C1.2,G,14.2 36.1, 35.8,1.1, 4.1	S.B.	GP	GP

	WIRING DIAGRAM	DWG NO.: D061780P0.2	REV.: 10
--	----------------	----------------------	----------

# Wiring diagram pages list

Multiplex outputs	<b>B1</b>	<b>D</b>		Hvac defroster	18,1	<b>R</b>	
Multiplex input	<b>B2</b>	Dash lights	19,1	Hvac passenger	18,2	Reading lamps	22,2
Multiplex Error list	<b>B3</b>	DC/DC Converter 12v	40,2			Rear Tachometer	14,3
Layout vehicle - harness	<b>C1</b>	Destination sign	28,1	<b>I</b>		Retarder	12.1 - 15.1
Pins configuration	<b>D</b>	Driver's light & backlight	19,1	Ignition & Engine Start	3,2	RJB fan	1,1
Circuits list	<b>E</b>	Driver window	30,1	Indirect lighting	23,1		
Circuit breakers list	<b>F</b>			Infotainment	35,3	<b>S</b>	
Connectors list	<b>G</b>	<b>E</b>		IVN Clever Device	35.8-35.9	Snow Chains	16,2
Diodes list	<b>H</b>	ELD Gateway	42,1			Speakers	35,2
Resistors list	<b>J</b>	Emergency & Aisle lights	20,1	<b>K</b>		Stop Request	22,2
Relays list	<b>K</b>	Engine ECU	14,1	Kneeling system&Hi Buoy	32,1	Spares wires	8,1
Fuses list	<b>L</b>	Engine heater	14,1			Stop lights	26,2
Wire identification chart	<b>M</b>	Engine start	3,2	<b>L</b>		Step lights	29,1
		Engine & RJB cmpt. Light	25,1	Luggage compartment Lighting	25,1		
<b>A</b>		Entrance door & lights	29,1			<b>T</b>	
AFSS KIDDE TLSE	38,2	ESP	16,1	<b>M</b>		Tag	32,1
Air dryer	37,1			Main dist. ignition & batt.	3,1	Tail & licence lights	26,2
Air Filter	14,3	<b>F</b>		Markers lights	26.1 - 26.2	Transmission ECU	15,1
Alternators	1,1	Fans radiator	13,1	Mirrors	31,1	Trailer (FR)	26,4
		FareBOX	28,1	Mobile View	35,7		
<b>B</b>		Fast idle	14,1	Multiplex power distribution	7,1	<b>U</b>	
Back-up warnings	26,3	Fire suppression system	38,1	Multiplex network	6.1 - 6.2	Ultracap	43,1
Batteries & Equalizer	1,1	Flashers	26.1-26.2			Upper defrost	18,4
Battery charger	17,1	Fuel gauge	10,1	<b>O</b>		Urea system	14,2
BCIS	35,1			OIL Separator	37,1		
Brake pedal sensor &Interlock	12,1	<b>G</b>				<b>V</b>	
Brake Wear	12,2	Grounds electronic	2,1	<b>P</b>		Volvo link TGW	37,1
		Grounds chassis	2,2	Parcel rack A/C system	18,3		
<b>C</b>				Park brake sensor	12,1	<b>W</b>	
Camera system	35,7	<b>H</b>		Power distribution FJB 12V	4,1	Wet Tank	37,1
Clearance lights	26.1-26.2	Hazard	26,1	Power distribution FJB 24V	4,2	Wheel chair lift Ricon	36,1
Cluster	10,1	Head lights	26,1	Pwr dist. RJB 12V & 24V	5,1	WIFI	35,4
Coolant Level Led	14,3	Horn	9,1	Pwr dist.P.RACK 12V & 24V	5,2	WIF Fuel Filter	14,1
Curb Light	21,1					Wipers & washer	34,1

# Wiring diagram pages list

Multiplex outputs	<b>B1</b>	<b>D</b>		Hvac defroster	18,1	<b>R</b>	
Multiplex input	<b>B2</b>	Dash lights	19,1	Hvac passenger	18,2	Reading lamps	22,2
Multiplex Error list	<b>B3</b>	DC/DC Converter 12v	40,2			Rear Tachometer	14,3
Layout vehicle - harness	<b>C1</b>	Destination sign	28,1	<b>I</b>		Retarder	12.1 - 15.1
Pins configuration	<b>D</b>	Driver's light & backlight	19,1	Ignition & Engine Start	3,2	RJB fan	1,1
Circuits list	<b>E</b>	Driver window	30,1	Indirect lighting	23,1		
Circuit breakers list	<b>F</b>			Infotainment	35,3	<b>S</b>	
Connectors list	<b>G</b>	<b>E</b>		IVN Clever Device	35.8-35.9	Snow Chains	16,2
Diodes list	<b>H</b>	ELD Gateway	42,1			Speakers	35,2
Resistors list	<b>J</b>	Emergency & Aisle lights	20,1	<b>K</b>		Stop Request	22,2
Relays list	<b>K</b>	Engine ECU	14,1	Kneeling system&Hi Buoy	32,1	Spares wires	8,1
Fuses list	<b>L</b>	Engine heater	14,1			Stop lights	26,2
Wire identification chart	<b>M</b>	Engine start	3,2	<b>L</b>		Step lights	29,1
		Engine & RJB cmpt. Light	25,1	Luggage compartment Lighting	25,1		
<b>A</b>		Entrance door & lights	29,1			<b>T</b>	
AFSS KIDDE TLSE	38,2	ESP	16,1	<b>M</b>		Tag	32,1
Air dryer	37,1			Main dist. ignition & batt.	3,1	Tail & licence lights	26,2
Air Filter	14,3	<b>F</b>		Markers lights	26.1 - 26.2	Transmission ECU	15,1
Alternators	1,1	Fans radiator	13,1	Mirrors	31,1	Trailer (FR)	26,4
		FareBOX	28,1	Mobile View	35,7		
<b>B</b>		Fast idle	14,1	Multiplex power distribution	7,1	<b>U</b>	
Back-up warnings	26,3	Fire suppression system	38,1	Multiplex network	6.1 - 6.2	Ultracap	43,1
Batteries & Equalizer	1,1	Flashers	26.1-26.2			Upper defrost	18,4
Battery charger	17,1	Fuel gauge	10,1	<b>O</b>		Urea system	14,2
BCIS	35,1			OIL Separator	37,1		
Brake pedal sensor &Interlock	12,1	<b>G</b>				<b>V</b>	
Brake Wear	12,2	Grounds electronic	2,1	<b>P</b>		Volvo link TGW	37,1
		Grounds chassis	2,2	Parcel rack A/C system	18,3		
<b>C</b>				Park brake sensor	12,1	<b>W</b>	
Camera system	35,7	<b>H</b>		Power distribution FJB 12V	4,1	Wet Tank	37,1
Clearance lights	26.1-26.2	Hazard	26,1	Power distribution FJB 24V	4,2	Wheel chair lift Ricon	36,1
Cluster	10,1	Head lights	26,1	Pwr dist. RJB 12V & 24V	5,1	WIFI	35,4
Coolant Level Led	14,3	Horn	9,1	Pwr dist.P.RACK 12V & 24V	5,2	WIF Fuel Filter	14,1
Curb Light	21,1					Wipers & washer	34,1

# Wiring diagram pages list

Multiplex outputs	<b>B1</b>	<b>D</b>		Hvac defroster	18.1	<b>R</b>	
Multiplex input	<b>B2</b>	Dash lights	19.1	Hvac passenger	18.2	Reading lamps	22.2
Multiplex Error list	<b>B3</b>	DC/DC Converter 12v	40.2			Rear Tachometer	14.3
Layout vehicle - harness	<b>C1</b>	Destination sign	28.1	<b>I</b>		Retarder	12.1 - 15.1
Pins configuration	<b>D</b>	Driver's light & backlight	19.1	Ignition & Engine Start	3.2	RJB fan	1.1
Circuits list	<b>E</b>	Driver window	30.1	Indirect lighting	23.1		
Circuit breakers list	<b>F</b>			Infotainment	35.3	<b>S</b>	
Connectors list	<b>G</b>	<b>E</b>		IVN Clever Device	35.8-35.9	Snow Chains	16.2
Diodes list	<b>H</b>	ELD Gateway	42.1			Speakers	35.2
Resistors list	<b>J</b>	Emergency & Aisle lights	20.1	<b>K</b>		Stop Request	22.2
Relays list	<b>K</b>	Engine ECU	14.1	Kneeling system&Hi Buoy	32.1	Spares wires	8.1
Fuses list	<b>L</b>	Engine heater	14.1			Stop lights	26.2
Wire identification chart	<b>M</b>	Engine start	3.2	<b>L</b>		Step lights	29.1
		Engine & RJB cmpt. Light	25.1	Luggage compartment Lighting	25.1		
<b>A</b>		Entrance door & lights	29.1			<b>T</b>	
AFSS KIDDE TLSE	38.2	ESP	16.1	<b>M</b>		Tag	32.1
Air dryer	37.1			Main dist. ignition & batt.	3.1	Tail & licence lights	26.2
Air Filter	14.3	<b>F</b>		Markers lights	26.1 - 26.2	Transmission ECU	15.1
Alternators	1.1	Fans radiator	13.1	Mirrors	31.1	Trailer (FR)	26.4
Able Syst	35.8	FareBOX	28.1	Mobile View	35.7		
		Fast idle	14.1	Multiplex power distribution	7.1	<b>U</b>	
<b>B</b>		Fire suppression system	38.1	Multiplex network	6.1 - 6.2	Ultracap	43.1
Back-up warnings	26.3	Flashers	26.1-26.2			Upper defrost	18.4
Batteries & Equalizer	1.1	Fuel gauge	10.1	<b>O</b>		Urea system	14.2
BCIS	35.1			OIL Separator	37.1		
Brake pedal sensor &Interlock	12.1	<b>G</b>				<b>V</b>	
Brake Wear	12.2	Grounds electronic	2.1	<b>P</b>		Volvo link TGW	37.1
		Grounds chassis	2.2	Parcel rack A/C system	18.3		
<b>C</b>				Park brake sensor	12.1	<b>W</b>	
Camera system	35.7	<b>H</b>		Power distribution FJB 12V	4.1	Wet Tank	37.1
Clearance lights	26.1-26.2	Hazard	26.1	Power distribution FJB 24V	4.2	Wheel chair lift Ricon	36.1
Cluster	10.1	Head lights	26.1	Pwr dist. RJB 12V & 24V	5.1	WIFI	35.4
Coolant Level Led	14.3	Horn	9.1	Pwr dist.P.RACK 12V & 24V	5.2	WIF Fuel Filter	14.1
Curb Light	21.1					Wipers & washer	34.1

## Vehicule Harness RoadMap

DESCRIPTION	NYCTA Phase3
ORDRE DE CHANGEMENT	2018165
VÉH. EFFECTIF	
T.I. RESPONSABLE	SB-CL-GP
ABS_FR_WHLS_HARNESS	069387
AFSS_LUGGAGE_HARNESS	0600034
Alt_battery_lh	0610247
Alt_battery	0610248
Alt_chassis_GND	0610249
Alt_Ctrl_harness	0610250
Alt_jumper_power	0610292
Alt_Lh_Chassis_Gnd	0610251
Alternator_HARNESS_LH	0610252
Batt_Charger_120V_ext	idemX3_060149
battery_12vd1_harness	0610336
battery_12vd_harness	069523
battery_24vd1_harness	069521
battery_24vd_harness	069522
battery_gnd_electro_harness	idemX3_069534
Battery_interconnect	idemX3_060152
BatteryGndHarness	idemX3_069525
BCIS_Y_CABLE	069079
BCIS_LRU_to_Key_Sw	0610305
Camera_IP_LH	0610306
Camera_IP_RH	0610307
Camera_IP_FR	0610308
Curb_Light_Roof_LH_RH	060058
Condensor_Harness	0610237
Dash	0610234
DC/DC_Harness	0610332
DPF_Door_Harness	0610253
DPF_Door_light	0610254
DPF_Volvo	0610255
electric_horn	idemX3_060074
ENGINE_ACCESSORIES	0610256
Engine_chassis_GND	0610257
ENGINE_CRADLE	0610258
Engine_door	0610233
Entrance_Door_GM_Sw	0610345
Emergency_light_RH	069986
Emergency_light_LH	069870
Equalizer_Harness_Vanner	idemX3_069539
Evap_Door_harness	idemX3_060556
Evap_HARNESS_Ctrl	idemX3_069981
Evap_Power_GND_harness	idemX3_060527
Evap_power_harness	idemX3_060529
FanDrive_harness	idemX3_068820
FanDrive_pwr24	0610267
FanDrive_pwrGnd	0610206
FJB	0610186
Front_Clearance_Harness	069823
FRONT_HARNESS	0610323
Front_Trailer_Harness	0610205
Fuel_gauge_Harness	idemX3_060087
head_lamp_LED_LH	0610223
head_lamp_led_RH	0610223
IND_LED_FrLh_RrRh	069861
IND_LED_FrRh_RrLh	069862

DESCRIPTION	NYCTA Phase3
ORDRE DE CHANGEMENT	2018165
VÉH. EFFECTIF	
T.I. RESPONSABLE	SB-CL-GP
IND_Front_LH	069985
Interior_light_Access	0610314
Jumper_Ground_Plate	0610327
Jumper_Indirect_Std	Idem_X3_069546
Jumper_Indirect_WCL	IdemX3_069884
LH_Console	0610235
Lugg_Harness	0610288
Parcel_Rack_24_ISM	0610326
Parcel_Rack_JB	0610346
Pneumatic_Plate_Harness	069715
Power_harness	idemX3_060558
Power_Vecr	idemX3_069540
PreHeate_relay	idemX3_069516
PreHeater_GND	idemX3_060308
Preheater_Thermal_harness	IdemX3_067676
Pwr_Bat_charger	idemX3_069528
Radiator_chassis_gnd	062315
reading_Light_LH	0610352
Reading_Lights_RH	0610351
Rear_lamps	0610226b
Relay_Melco_batt	idemX3_069542
RJB	0610236
RJB_Ctrl	0611010
RJB_Rr_Seat_Harn_ElectGND	069698
Rr_Clearance_harness	069829
service_Door_Harness	IDEMX3_069554
Starter_battery_Volvo	0610259
Starter_chassis_GND	0610260
starter_relay_Melco_VOLVO	0610261
Starting_Aid_Ultracap	0610353
Trans_Fr_Rr	0610230
TransSensorWithRetarder_harness	0610262
Trailer_Rr_Fr_Harness	0610246
TWS_LH	0610293
TWS_RH	0610294
Ultracap_power	060422
UPPER_Front_ACC	0610263
Upper_Front_Acc_Pwr	0610348
Urea_Harness	0611012
USB_LH	0610330
USB_RH_Fr	0610333
USB_RH_Rr	0610344
USB_JUMPER_WCL	0610339
USB_JUMPER_wall	0610338
VIP_relay_harness	069262
USB_JUMPER_Modest	0610341
WCL_IOE_Control	0610287
WCL_LUGG_DOOR_LOCK	idemX3_069339
wcl_power_harness	idemX3_069337
WCL_Sliding_Door_2016	069780
WCL_Ricon_access	069744
WCL_UPPER_DOOR_CTRL	069784
WCL_Window_Sw_LH	069859

# Vehicule Harness RoadMap

DESCRIPTION	NYCTA Phase3
ORDRE DE CHANGEMENT	2018165
VÉH. EFFECTIF	
ABS_FR WHLS HARNESS	069387
AFSS LUGGAGE HARNESS	0600034
Alt battery lh	0610247
Alt battery	0610248
Alt chassis GND	0610249
Alt Ctrl harness	0610250
Alt jumper power	0610292
Alt Lh Chassis Gnd	0610251
Alternator HARNESS LH	0610252
Batt Charger 120V ext	idemX3_060149
battery 12vd1 harness	0610426
battery 12vd2 harness	0610427
battery 12vd harness	069523
battery 24vd1 harness	0610424
battery 24vd2 harness	0610425
battery 24vd harness	069522
battery gnd electro harness	idemX3_069534
Battery interconnect	idemX3_060152
BatteryGndHarness	idemX3_069525
BCIS Y CABLE	069079
BCIS LRU to Key Sw	0610305
Camera IP LH	0610306
Camera IP RH	0610307
Camera IP FR	0610308
Curb Light Roof LH RH	060058
Condensor Harness	0610237
Dash	0610234
DC/DC Harness	0610332
DPF Door Harness	0610253
DPF Door light	0610254
DPF Volvo	0610255
electric horn	idemX3_060074
ENGINE ACCESSORIES	0610256
Engine chassis GND	0610257
ENGINE CRADLE	0610258
Engine door	0610233
Entrance Door GM Sw	0610345
Emergency light RH	069986
Emergency light LH	069870
Equalizer Harness Vanner	idemX3_069539
Evap Door harness	idemX3_060556
Evap HARNESS Ctrl	idemX3_069981
Evap Power GND harness	idemX3_060527
Evap power harness	idemX3_060529
FanDrive harness	idemX3_068820
FanDrive pwr24	0610267
FanDrive pwrGnd	0610206
FJB	0610186
Front Clearance Harness	069823
FRONT HARNESS	0610323
Front Trailer Harness	0610205
Fuel gauge Harness	idemX3_060087
head lamp LED LH	0610223
head_lamp_led_RH	0610223
IND LED FrLh RrRh	069861

DESCRIPTION	NYCTA Phase3
ORDRE DE CHANGEMENT	2018165
VÉH. EFFECTIF	
IND LED FrRh RrLh	069862
IND Front LH	069985
Interior light Access	0610314
Jumper Ground Plate	0610327
Jumper Indirect Std	Idem_X3_069546
Jumper Indirect WCL	IdemX3_069884
LH Console	0610235
Lugg Harness	0610288
Parcel Rack 24 ISM	0610326
Parcel Rack JB	0610346
Pneumatic Plate Harness	0610406
Power harness	idemX3_060558
Power Vecr	idemX3_069540
PreHeate relay	idemX3_069516
PreHeater GND	idemX3_060308
Preheater Thermal harness	IdemX3_067676
Pwr Bat charger	idemX3_069528
Radiator chassis gnd	062315
reading Light LH	0610352
Reading Lights RH	0610351
Rear lamps	0610226b
Relay Melco batt	idemX3_069542
RJB	0610236
RJB Ctrl	0611010
RJB Rr Seat Harn ElectGND	069698
Rr Clearance harness	069829
service Door Harness	IDEMX3_069554
Starter battery Volvo	0610259
Starter chassis GND	0610260
starter relay Melco VOLVO	0610261
Starting Aid Ultracap	0610353
Trans Fr Rr	0610230
TransSensorWithRetarder harness	0610262
Trailer Rr Fr Harness	0610246
TWS LH	0610293
TWS RH	0610294
Ultracap power	060422
UPPER Front ACC	0610263
Upper Front Acc Pwr	0610348
Urea Harness	0611012
USB LH	0610330
USB RH Fr	0610333
USB RH Rr	0610344
USB JUMPER WCL	0610339
USB JUMPER wall	0610338
VIP relay harness	069262
USB JUMPER Modest	0610341
WCL IOE Control	0610287
WCL LUGG DOOR LOCK	idemX3_069339
wcl power harness	idemX3_069337
WCL Sliding Door 2016	069780
WCL Ricon access	069744
WCL UPPER DOOR CTRL	069784
WCL Window Sw LH	069859

## Vehicule Harness RoadMap

DESCRIPTION	OBD21	Syst Able
ORDRE DE CHANGEMENT	2021001	2020085
VÉH. EFFECTIF	7848	7829
ABS FR WHLS HARNESS	069387	
AFSS LUGGAGE HARNESS	0600034	
Alt battery lh	0610247	
Alt battery	0610248	
Alt chassis GND	0610249	
Alt Ctrl harness	0610250	
Alt jumper power	0610292	
Alt Lh Chassis Gnd	0610251	
Alternator HARNESS LH	0610252	
Batt Charger 120V ext	idemX3 060149	
battery 12vd1 harness	0610426	
battery 12vd2 harness	0610427	
battery 12vd harness	069523	
battery 24vd1 harness	0610424	
battery 24vd2 harness	0610425	
battery 24vd harness	069522	
battery gnd electro harness	idemX3 069534	
Battery interconnect	idemX3 060152	
BatteryGndHarness	idemX3 069525	
BCIS Y CABLE	069079	
BCIS LRU to Key Sw	0610305	
Camera IP LH	0610306	
Camera IP RH	0610307	
Camera IP FR	0610308	
Curb Light Roof LH RH	060058	
Condensor Harness	0610237	
Dash	0610458	
DC/DC Harness	0610332	
DPF Door Harness	0610253	
DPF Door light	0610254	
DPF Volvo	0610255	
electric horn	idemX3 060074	
ENGINE ACCESSORIES	0610256	
Engine chassis GND	0610257	
ENGINE CRADLE	0610258	
Engine door	0610233	
Entrance Door GM Sw	0610345	
Emergency light RH	069986	
Emergency light LH	069870	
Equalizer Harness Vanner	idemX3 069539	
Evap Door harness	idemX3 060556	
Evap HARNESS Ctrl	idemX3 069981	
Evap Power GND harness	idemX3 060527	
Evap power harness	idemX3 060529	
FanDrive harness	idemX3 068820	
FanDrive_pwr24	0610267	
FanDrive_pwrGnd	0610206	
FJB	0610454	
Front Clearance Harness	069823	
FRONT HARNESS	0610483	
Front Trailer Harness	0610205	
Fuel gauge Harness	idemX3 060087	
head lamp LED LH	0610223	
head lamp led RH	0610223	
IND_LED_FrLh_RrRh	069861	



## Vehicule Harness RoadMap

DESCRIPTION	OBD21	Syst Able
ORDRE DE CHANGEMENT	2021001	2020085
VÉH. EFFECTIF	7848	7829
IND LED FrRh RrLh	069862	
IND Front LH	069985	
Interior light Access	0610314	
Jumper Ground Plate	0610327	
Jumper Indirect Std	Idem X3 069546	
Jumper Indirect WCL	IdemX3 069884	
LH Console	0610235	
Lugg Harness	0610288	
Parcel Rack 24 ISM	0610326	
Parcel Rack JB	0610346	
Pneumatic Plate Harness	0610459	
Power harness	idemX3 060558	
Power Vecr	idemX3 069540	
PreHeate relay	idemX3 069516	
PreHeater GND	idemX3 060308	
Preheater Thermal harness	IdemX3 067676	
Pwr Bat charger	idemX3 069528	
Radiator chassis gnd	062315	
reading Light LH	0610352	
Reading Lights RH	0610351	
Rear lamps	0610226b	
Relay Melco batt	idemX3 069542	
RJB	0610456	
RJB Ctrl	0610457	
RJB Rr Seat Harn ElectGND	069698	
Rr Clearance harness	069829	
service Door Harness	IDEMX3 069554	
Starter battery Volvo	0610259	
Starter chassis GND	0610260	
starter relay Melco VOLVO	0610261	
Starting Aid Ultracap	0610353	
Trans Fr Rr	0610455	
TransSensorWithRetarder harness	0610262	
Trailer Rr Fr Harness	0610246	
TWS LH	0610293	
TWS RH	0610294	
Ultracap power	060422	
UPPER Front ACC	0610263	0610529
Upper Front Acc Pwr	0610348	
Urea Harness	0611012	
USB LH	0610330	
USB RH Fr	0610333	
USB RH Rr	0610344	
USB JUMPER WCL	0610339	
USB JUMPER_wall	0610338	
VIP relay harness	069262	
USB JUMPER Modest	0610341	
WCL IOE Control	0610287	
WCL LUGG DOOR LOCK	idemX3 069339	
wcl power harness	idemX3 069337	
WCL Sliding Door 2016	069780	
WCL Ricon access	069744	
WCL UPPER DOOR CTRL	069784	
WCL Window Sw LH	069859	

## Vehicule Harness RoadMap

DESCRIPTION	Syst Able	OBD22
ORDRE DE CHANGEMENT	2020085	2022001
VÉH. EFFECTIF	7829	8008
ABS FR WHLS HARNESS	069387	
AFSS LUGGAGE HARNESS	0600034	
Alt battery lh	0610247	
Alt battery	0610248	
Alt chassis GND	0610249	
Alt Ctrl harness	0610250	
Alt jumper power	0610292	
Alt Lh Chassis Gnd	0610251	
Alternator HARNESS LH	0610252	
Batt Charger 120V ext	idemX3 060149	
battery 12vd1 harness	0610426	
battery 12vd2 harness	0610427	
battery 12vd harness	069523	
battery 24vd1 harness	0610424	
battery 24vd2 harness	0610425	
battery 24vd harness	069522	
battery gnd electro harness	idemX3 069534	
Battery interconnect	idemX3 060152	
BatteryGndHarness	idemX3 069525	
BCIS Y CABLE	069079	
BCIS LRU to Key Sw	0610305	
Camera IP LH	0610306	
Camera IP RH	0610307	
Camera IP FR	0610308	
Curb Light Roof LH RH	060058	
Condensor Harness	0610237	
Dash	0610458	
DC/DC Harness	0610332	
DPF Door Harness	0610253	
DPF Door light	0610254	
DPF Volvo	0610255	
electric horn	idemX3 060074	
ENGINE ACCESSORIES	0610256	
Engine chassis GND	0610257	
ENGINE CRADLE	0610258	
Engine door	0610233	
Entrance Door GM Sw	0610345	
Emergency light RH	069986	
Emergency light LH	069870	
Equalizer Harness Vanner	idemX3 069539	
Evap Door harness	idemX3 060556	
Evap HARNESS Ctrl	idemX3 069981	
Evap Power GND harness	idemX3 060527	
Evap power harness	idemX3 060529	
FanDrive harness	idemX3 068820	
FanDrive_pwr24	0610267	
FanDrive_pwrGnd	0610206	
FJB	0610454	
Front Clearance Harness	069823	
FRONT HARNESS	0610483	
Front Trailer Harness	0610205	
Fuel gauge Harness	idemX3 060087	
head lamp LED LH	0610223	
head lamp led RH	0610223	
IND_LED_FrLh_RrRh	069861	

## Vehicule Harness RoadMap

<b>DESCRIPTION</b>	<b>Syst Able</b>	<b>OBD22</b>
<b>ORDRE DE CHANGEMENT</b>	<b>2020085</b>	<b>2022001</b>
<b>VÉH. EFFECTIF</b>	<b>7829</b>	<b>8008</b>
IND LED FrRh RrLh	069862	
IND Front LH	069985	
Interior light Access	0610314	
Jumper Ground Plate	0610327	
Jumper Indirect Std	Idem X3 069546	
Jumper Indirect WCL	IdemX3 069884	
LH Console	0610235	
Lugg Harness	0610288	
Parcel Rack 24 ISM	0610326	
Parcel Rack JB	0610346	
Pneumatic Plate Harness	0610459	
Power harness	idemX3 060558	
Power Vecr	idemX3 069540	
PreHeate relay	idemX3 069516	
PreHeater GND	idemX3 060308	
Preheater Thermal harness	IdemX3 067676	
Pwr Bat charger	idemX3 069528	
Radiator chassis gnd	062315	
reading Light LH	0610352	
Reading Lights RH	0610351	
Rear lamps	0610226b	
Relay Melco batt	idemX3 069542	
RJB	0610456	
RJB Ctrl	0610457	
RJB Rr Seat Harn ElectGND	069698	
Rr Clearance harness	069829	
service Door Harness	IDEMX3 069554	
Starter battery Volvo	0610259	
Starter chassis GND	0610260	
starter relay Melco VOLVO	0610261	
Starting Aid Ultracap	0610353	
Trans Fr Rr	0610455	
TransSensorWithRetarder harness	0610262	0610594
Trailer Rr Fr Harness	0610246	
TWS LH	0610293	
TWS RH	0610294	
Ultracap power	060422	
UPPER Front ACC	0610529	
Upper Front Acc Pwr	0610348	
Urea Harness	0611012	IDEMX3 0610591
USB LH	0610330	
USB RH Fr	0610333	
USB RH Rr	0610344	
USB JUMPER WCL	0610339	
USB JUMPER_wall	0610338	
VIP relay harness	069262	
USB JUMPER Modest	0610341	
WCL IOE Control	0610287	
WCL LUGG DOOR LOCK	idemX3 069339	
wcl power harness	idemX3 069337	
WCL Sliding Door 2016	069780	
WCL Ricon access	069744	
WCL UPPER DOOR CTRL	069784	
WCL Window Sw LH	069859	

## Wiring diagram pages list

### Pin configuration MCM

Signal ID	J1 pin	Interface type	Input / Output	Description	Signal ID	J1 pin	Interface type	Input / Output	Description
A1	1	CAN0 High	Bus	Maximum speed 1Mbps/wake	B1	1	Type 1	In	LDI, HDI
A2	2	CAN0 Low	Bus	Maximum speed 1Mbps/wake	B2	2	Type 1	In	LDI, HDI, Failure mode
A3	3	Type 7	Out	LDO, Failure mode	B3	3	Type 2	In	HDI
A4	4	Type 7	Out	LDO	B4	4	Type 4a	In	HDI, Interrupt/Wake
A5	5	Type 7	Out	LDO	B5	5	Type 3	In	LDI, Interrupt/Wake
A6	6	Type 8	Out	LDO	B6	6	Type 4a	In	HDI Failure mode, Interrupt/Wake
A7	7	Type 8	Out	LDO	B7	7	RS232 TxD	Bus	Maximum speed 115,2kbps
A8	8	GND	In		B8	8	RS232 RxD	Bus	Maximum speed 115,2kbps
A9	9	Vbat	In		B9	9	Type 1	In	LDI, HDI
A10	10	Type 8	Out	LDO	B10	10	Type 1	In	LDI, HDI
A11	11	Type 10	Out	HDO	B11	11	Type 1	In	LDI, HDI
A12	12	Type 9B	Out	HDO	B12	12	RS232 GND	In	
A13	13	Type 9B	Out	HDO	B13	13	Type 1	In	LDI, HDI
A14	14	Type 9A	Out	HDO	B14	14	Type 1	In	LDI, HDI
A15	15	Type 9A	Out	HDO	B15	15	Type 4B	In	Interrupt/Wake
A16	16	Type 9A	Out	HDO, Failure mode	B16	16	Type 1	In	LDI, HDI
A17	17	Type 10	Out	HDO, Failure mode	B17	17	Type 1	In	LDI, HDI
A18	18	Type 9A	Out	HDO	B18	18	GND	In	
A19	19	Type 13	Out	C30	B19	19	MasterID	In	
A20	20	Network ID 1	In		B20	20	Supply		
A21	21	Network ID 2	In		B21	21	NC		
A22	22	EOL enable	In		B22	22	Type 1	In	LDI, HDI
A23	23	Network ID 3	In		B23	23	Type 1	In	LDI, HDI
A24	24	Type 11	Out	HLDO	B24	24	RS232 CTS	In	
A25	25	Type 11	Out	HLDO	B25	25	Type 6	In	HAI
A26	26	Type 5	In	HDI	B26	26	Type 6	In	HAI
A27	27	CAN2 High	Bus	Maximum speed 1Mbps/wake	B27	27	RS232 RTS	Out	
A28	28	CAN2 Low	Bus	Maximum speed 1Mbps/wake	B28	28	Type 12	Out	HDO 5V
A29	29	GND	In		B29	29	Type 9	Out	HDO
A30	30	Vbat	In		B30	30	NC		

# Wiring diagram pages list

## Pin configuration MCM

### Interface Circuit type 1, General purpose digital input

The input can be used as a general input circuit interfacing to switches closing to ground and to battery (LDI/HDI). It can also be used to interface with resistive switches and sensors.

DC model of this circuit:

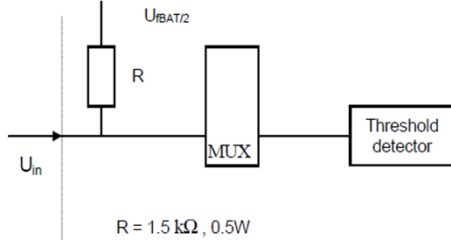

### Input circuit type 2, High side digital input

DC model of input circuit type 2. The input is used to interface with switches closing to battery voltage (HDI).

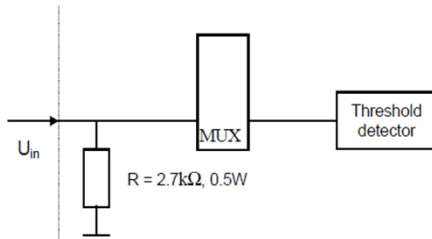

### Input circuit type 3, Low side digital input, interrupt

DC model of input circuit type 3. The input is used to interface with switches closing to ground voltage (LDI).

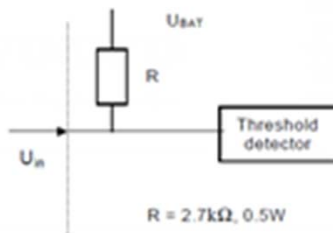

### Input circuit type 4a, High side digital input, interrupt

DC model of input circuit type 4. The input is used to interface with switches closing to battery voltage (HDI)

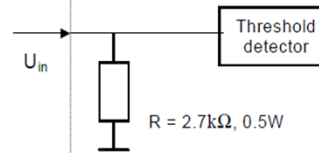

### Input circuit type 4b, High side digital input, interrupt

The input is used to wake up the CECM from sleep mode.

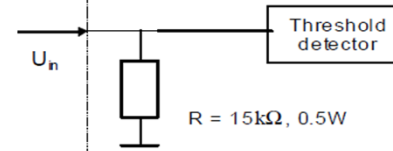

### Input circuit type 5, High side digital input

DC model of input circuit type 5. the inputs is used to interface with switches closing to battery voltage

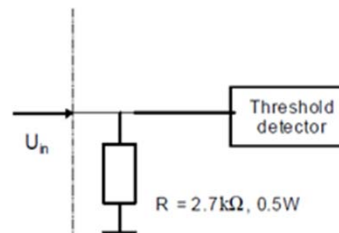

# Wiring diagram pages list

## Pin configuration MCM

Input circuit type 6, Analogue input

The circuit is used as interface to variable voltage sources such as potentiometers and analogue sensors (HA1).  
DC model of input circuit type 6:

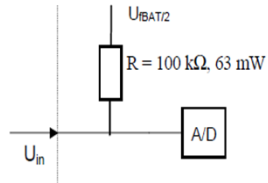

Output circuit type 7, LDO.

The figure below gives a schematic overview of the output type 7.

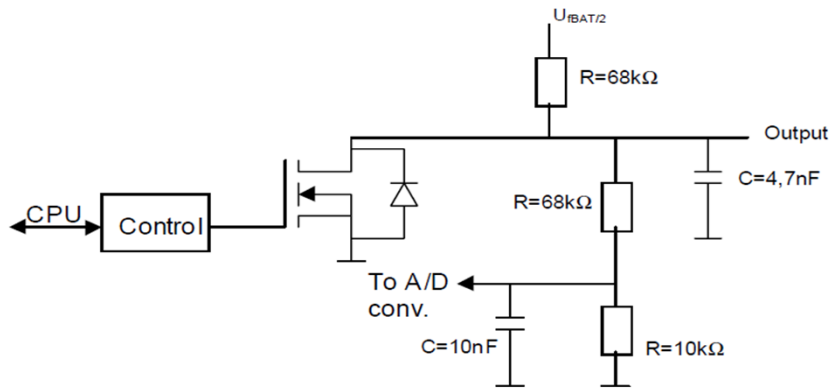

Output circuit type 8, LDO.

The figure below gives a schematic overview of the output type 8.

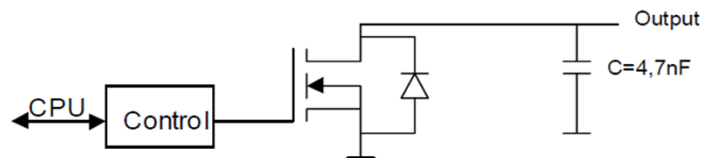

Output circuit type 9 a/b, HDO.

The figure below gives a schematic overview of the output type 9 a/b.

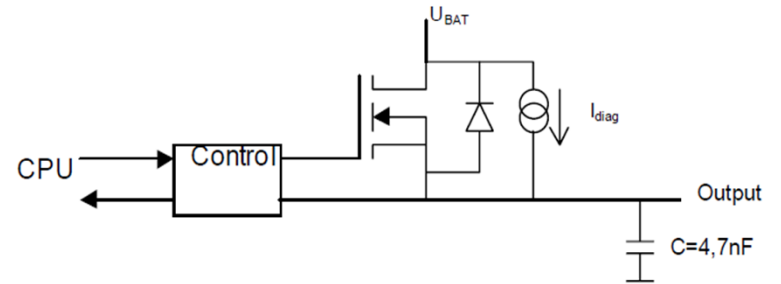

Output circuit type 10, HDO.

The figure below gives a schematic overview of the output type 10.

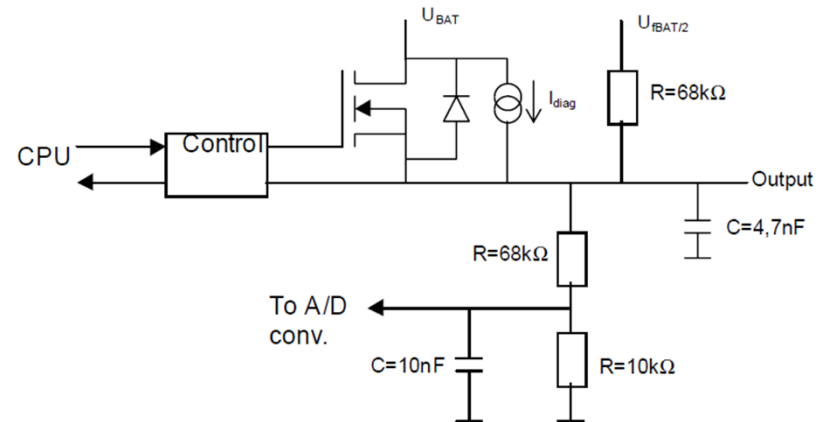

# Wiring diagram pages list

## Pin configuration MCM

Output circuit type 11, L/HDO, PWM<sub>out</sub>.

The figure below gives a schematic overview of the output type 11.

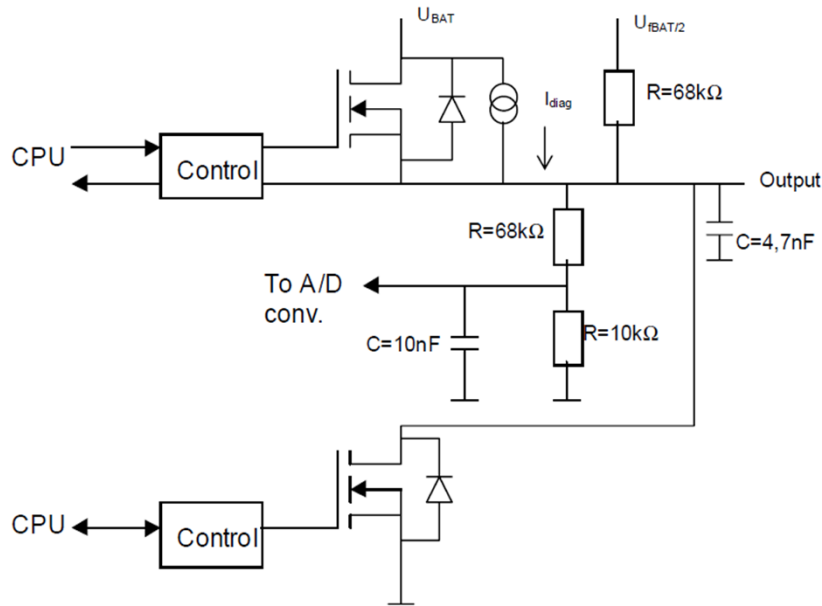

Output circuit type 12, HDO, 5V output and type 13, HDO.

The figure below gives a schematic overview of the output type 12 and 13.

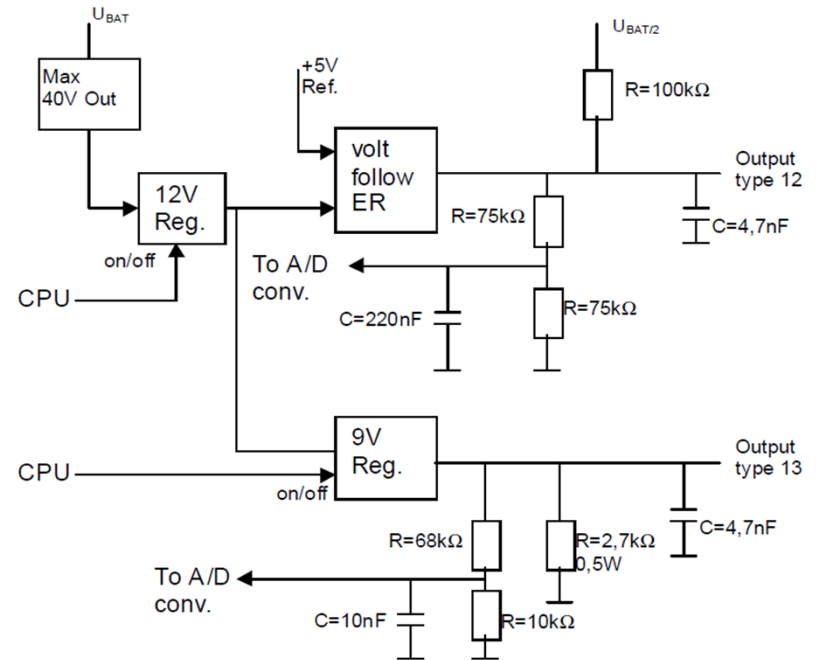

## Wiring diagram pages list

### Pin configuration I/O-A+

Signal ID	J1 pin	Interface type	Input / Output	Description	Max current average	Max current peak	Signal ID	J1 pin	Interface type	Input / Output	Description	Max current average	Max current peak
J1-1	1	4c	Out	HDO, LDO, HLDO, HPO	1A	1A	J2-6	6	1a	In	HDI, LDI, HLDI, RAI	*	*
J1-2	2	1a, 1b, 1c	In	HDI, LDI, HLDI, RES, RES32K, AI5V, RAI, CNTR1, CNTR2	*	*	J2-7	7	1a	In	HDI, LDI, HLDI, RAI	*	*
J1-3	3	4c	Out	HDO, LDO, HLDO, HPO	1A	1A	J2-8	8	1a	In	HDI, LDI, HLDI, RAI	*	*
J1-4	4	4c	Out	HDO, LDO, HLDO, HPO	1A	1A	J2-9	9	1a	In	HDI, LDI, HLDI, RAI	*	*
J1-5	5	1a, 1b, 1c	In	HDI, LDI, HLDI, RES, RES32K, AI5V, RAI, CNTR1, CNTR2	*	*	J2-10	10	1a	In	HDI, LDI, HLDI, RAI	*	*
J1-6	6	GND	In	Analog GND	*	*	J2-11	11	1a	In	HDI, LDI, HLDI, RAI	*	*
J1-7	7	4c	Out	HDO, LDO, HLDO, HPO	1A	1A	J2-12	12	1a	In	HDI, LDI, HLDI, RAI	*	*
J1-8	8	Network ID	In	NI	*	*	J2-13	13	1a	In	HDI, LDI, HLDI, RAI	*	*
J1-9	9	Network ID	In	NI	*	*	J2-14	14	GND	Out	Analog GND	*	*
J1-10	10	4c	Out	HDO, LDO, HLDO, HPO	1A	1A	J2-15	15	3a, 5	Out	HDO, REFCTL	50mA	50mA
J1-11	11	Network ID	In	NI	*	*							
J1-12	12	Network ID	In	NI	*	*							
J1-13	13	4c	Out	HDO, LDO, HLDO, HPO	*	*							
J1-14	14	Network ID	In	NI	*	*							
J1-15	15	Network ID	In	NI	*	*							
J1-16	16	4b	Out	HDO, LDO, HLDO, HPO, LPO	*	*							
J1-17	17	1a, 1c	In	HDI, LDI, HLDI, RES, RES32K, AI5V, RAI, CNTR1	*	*							
J1-18	18	GND	In	GND	*	*							
J1-19	19	4b	Out	HDO, LDO, HLDO, HPO, LPO	1A	1A							
J1-20	20	1a, 1c	In	HDI, LDI, HLDI, RES, RES32K, AI5V, RAI	*	*							
J1-21	21	1a	In	HDI, LDI, HLDI, RES, RES32K, AI5V, RAI	*	*							



## Wiring diagram pages list

### Pin configuration I/O-B+

Signal ID	J1 pin	Interface type	Input / Output	Description	Max current average	Max current peak	Signal ID	J1 pin	Interface type	Input / Output	Description	Max current average	Max current peak
J1-1	1	4d	Out	HDO, LDO, HLDO, HPO, LPO	16A	20A	J2-1	1	4d	Out	HDO, LDO, HLDO, HPO, LPO	10A	20A
J1-2	2	*	*	*	*	*	J2-2	2	GND	*	*	*	*
J1-3	3	4d	out	HDO, LDO, HLDO, HPO, LPO	16A	20A	J2-3	3	GND	*	*	*	*
J1-4	4	3c	Out	HDO	10A	20A	J2-4	4	4d	Out	HDO, LDO, HLDO, HPO, LPO	10A	20A
J1-5	5	GND	*	*	*	*	J2-5	5	1a, 2b, 6	In	HDI, LDI, HLDI, RAI, AI5V, RES, RES32K, CNTR, wake-up	*	*
J1-6	6	GND	Out	Analogue GND	*	*	J2-6	6	1a, 2b, 6	In	HDI, LDI, HLDI, RAI, AI5V, RES, RES32K, CNTR, wake-up	*	*
J1-7	7	3c	Out	HDO	10A	20A	J2-7	7	4c	In	HDO, LDO, HLDO, HPO	10A	20A
J1-8	8	NI	*	*	*	*	J2-8	8	1a,1b,1c	In	HDI, LDI, HLDI, RAI, AI5V, RES, RES32K	*	*
J1-9	9	NI	*	*	*	*	J2-9	9	1a,1b,1c	In	HDI, LDI, HLDI, RAI, AI5V, RES, RES32K	*	*
J1-10	10	3c	Out	HDO	10A	20A	J2-10	10	4c	Out	HDO, LDO, HLDO, HPO	10A	20A
J1-11	11	NI	*	*	*	*	J2-11	11	1b, 1c	In	AI5V, RES, RES32K	*	*
J1-12	12	NI	*	*	*	*	J2-12	12	1b, 1c	In	AI5V, RES, RES32K	*	*
J1-13	13	3c	Out	HDO	10A	20A	J2-13	13	3e	Out	HDO, LDO, HLDO	10A	20A
J1-14	14	NI	*	*	*	*	J2-14	14	GND	Out	Analogue GND	*	*
J1-15	15	NI	*	*	*	*	J2-15	15	5	Out	REFMEA	< 50 mA	*
J1-16	16	3c	Out	HDO	10A	20A							
J1-17	17	GND	*	*	*	*							
J1-18	18	GND	*	*	*	*							
J1-19	19	3c	Out	HDO	10A	20A							
J1-20	20	1a	In	HDI, LDI, HLDI, RAI	*	*							
J1-21	21	1a	In	HDI, LDI, HLDI, RAI	*	*							

# Wiring diagram pages list

## Pin configuration I/O-A+ and I/O-B+

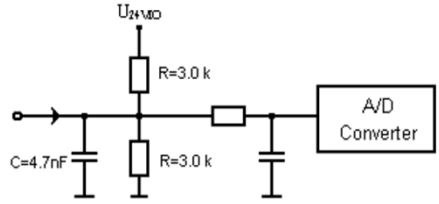
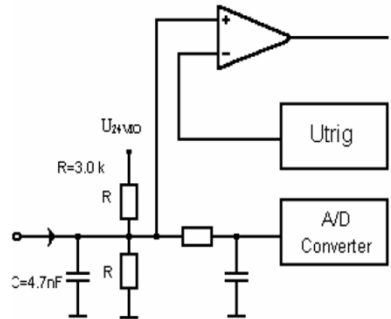
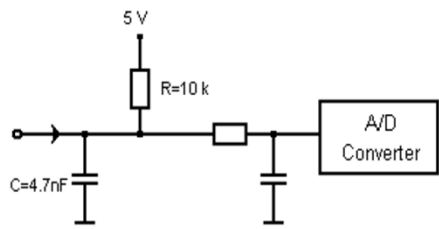
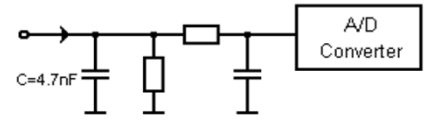
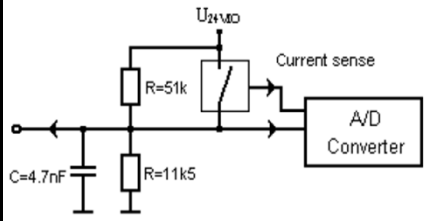
<p><b>Interface circuit 1a</b></p> <p>The input can be used for both digital and analogue signals that have <math>U_{24VIO}</math> as reference. The circuit shall sink 8 mA when connected to <math>U_{24VIO}</math> or source 8 mA when connected to GND. The input shall be converted from analog voltage to digital 10 bit resolution with scaling relative to <math>U_{24VIO}</math>. The input shall be regarded as a power line according to "Volvo Technical Regulation 15 79 908, EMC Requirements".</p> <p>Model of the input circuit:</p> 	<p><b>Interface circuit 2b</b></p> <p>Pulse input circuit. The input can be used for both digital and analogue signals and as pulse counter input with fixed trigger level. The circuit shall sink or source 8 mA at <math>U_{24VIO} = 28 V</math> when connected to <math>U_{24VIO}</math> or GND.</p> <p>Model of input circuit:</p> 
<p><b>Interface circuit 1b</b></p> <p>The input is used for resistive sensors. The circuit shall supply 5 V through a resistor of 10 kΩ. When used to measure temperature, the output current to the sensor shall then be minimised to avoid internal power dissipation in the sensor.</p> <p>Model of the input circuit:</p> 	<p><b>Interface circuit 3a</b></p> <p>Model of high side output stage circuit same as interface circuit 3b in Chapter 2.3.1.5.2, but without PWM capability and no biasing resistors for open circuit detection.</p>
<p><b>Interface circuit 1c</b></p> <p>The input can be used for both digital and analogue signals. The total input resistance <math>R_{tot} = R // R_{A/D}</math>, shall be <math>100 k\Omega &lt; R_{tot} &lt; 500 k\Omega</math>.</p> <p>Model of the input circuit:</p> 	<p><b>Interface circuit 3c</b></p> <p>High side output circuit. The switch provides current sense signal to an A/D converter. To detect open circuit when the switch is open the interface shall sink approximately 2 mA when connected to <math>U_{24VIO} = 28V</math> or source approximately 0.5 mA when connected to GND. The voltage shall be converted to digital 10 bit resolution with scaling relative to <math>U_{24VIO}</math>. The interface shall not be regarded as a power line according to "Volvo Technical Regulation 15 79 908, EMC Requirements".</p> <p>Model of the output circuit:</p> 

# Wiring diagram pages list

## Pin configuration I/O-A+ and I/O-B+

### Interface circuit 3e

Model of high side, low side output stage. This circuit is similar to circuit 4b but without PWM drive capabilities.

### Interface circuit 4b

Totem pole output stage may be used as high side, low side or high/low switch. Capable of low frequency PWM driving high side or low side switch but not both synchronously. Open circuit voltage shall be approximately  $9,2 V / U_{24VIO=28V}$ . When the switch is open the interface shall sink approximately 2 mA if connected to  $U_{24VIO=28V}$  or source 0,5 mA when connected to GND. The voltage shall be converted to digital 10 bit resolution with scaling relative to  $U_{24VIO}$ . The interface shall not be regarded as a power line according to "Volvo Technical Regulation 15 79 908, EMC Requirements".

Model of the output circuit:

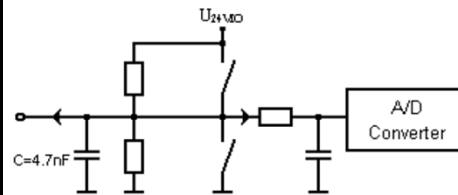

### Interface circuit 4c

Model of high side, low side output stage. This circuit is similar to circuit 4b but without low side PWM drive capabilities.

### Interface circuit 4d

Totem pole output stage may be used as high side, low side or high/low switch. Capable of low frequency PWM driving high side or low side switch but not both synchronously. Both switches provide current sense signal to an A/D converter. To detect open circuit when the switches are open the interface shall sink approximately 2 mA when connected to  $U_{24VIO=28V}$  or source approximately 0,5 mA when connected to GND. The voltage shall be converted to digital 10 bit resolution with scaling relative to  $U_{24VIO}$ . The interface shall not be regarded as a power line according to "Volvo Technical Regulation 15 79 908, EMC Requirements".

Model of the output circuit:

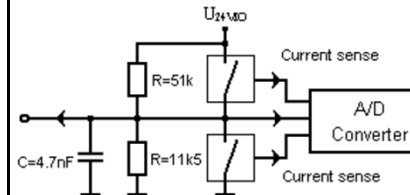

### Interface circuit 5

Model of a 5 V reference voltage supply for potentiometers and pressure sensors. Supply current 20 mA, current limited to < 50 mA.

Model of the output circuit:

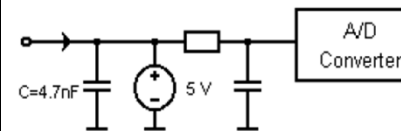

### Interface circuit 6

The pin is used for interrupt the ECU. Same interface as circuit 1a. The application software can initiate the interrupt function. The pin is used for waking-up the ECU from sleep mode.

# Wiring diagram pages list

## Radiator fans drive junction box

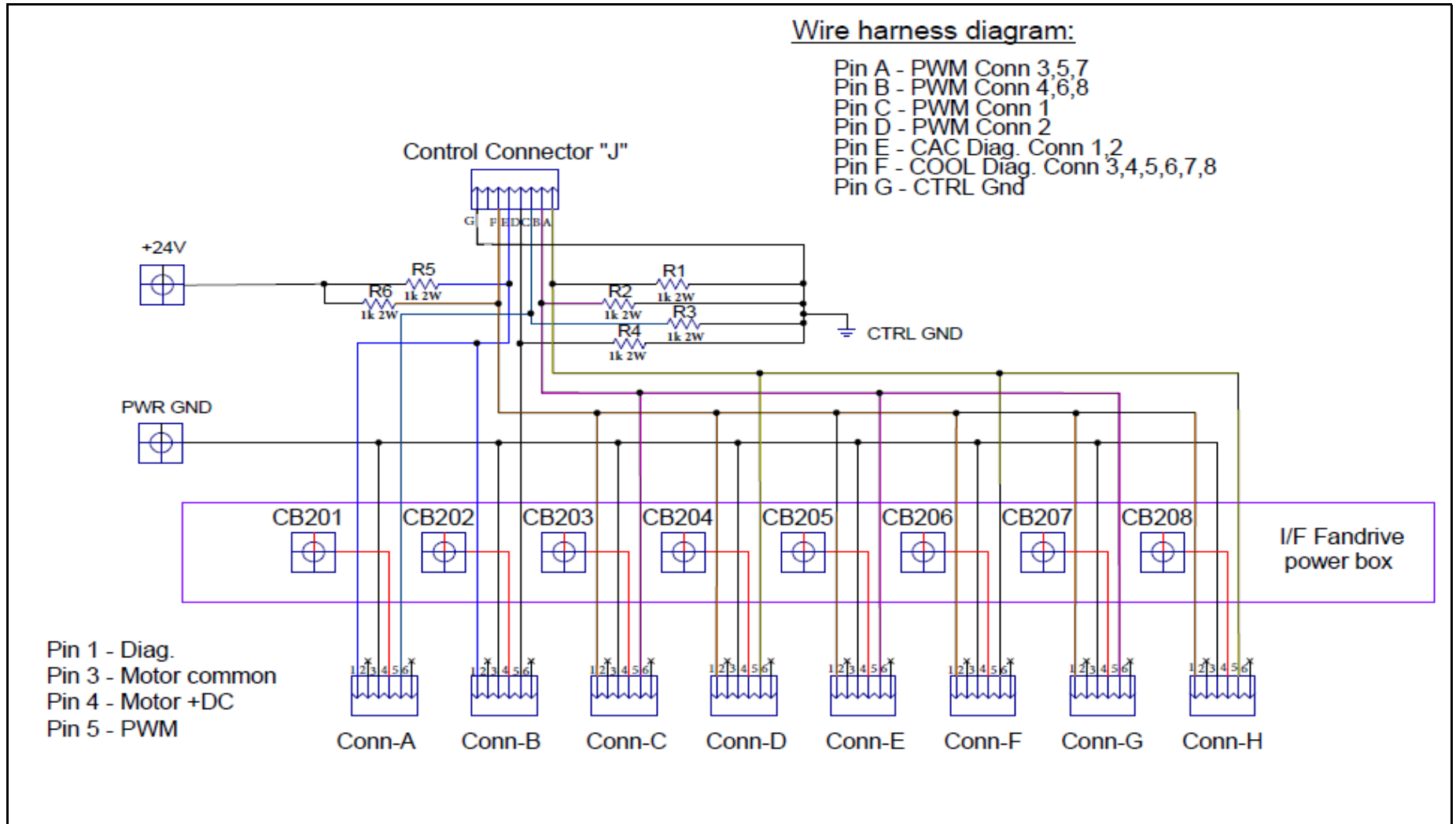

# CIRCUITS LIST

CircuitID	Description	CircuitID	Description	CircuitID	Description
0	Battery	00R2	gndIO-BA54	503	WheelChairLift
0A	GNDWiperwasher	0R3	GndCustomer	900	J1587+
00A	GndEntranceDoor	00R3	ElectronicGndofA50_A49	901	J1587-
00A1	Gnd_to_A56_A55_A15	0R4	AFSS	A1.11	Transmission
00A2	GndSw25	00R4	ElectronicGndofA57_A51	A1.12	ShifterSignal
0AltLL	ChassisGnd	00R5	VannerCtr	A1.15	Transmission
0AltR	ChassisGnd	0RAD	EngineChassisGnd	A1.16	Transmission
0B	EngineChassisGnd	0RAD2	FanDriveElectric	A1.18	Transmission
0C	GndStarter	0RJB2	GndCustomer	A1.19	Transmission
0Chgr	Battery_Charger_Gnd	00RS	GNDECM	A1.24	Transmission
0COND	CondensorGnd	00S	DCDCConverter	A1.25	Speed_Signal
0DC	GndDC/DC	0SS	GNDStud	A1.31	Transmission
0ECU	GndEnginePreheater	0SW	IndirectLighting	A1.33	Transmission
0EV1	EvaporatorMain	0SW1	IndirectLighting	A1.36	Transmission
0EV2	Evap_Compt_Gnd	00VA	Equalizer	A1.37	Transmission
0F	GNDTGW	0W	WCLGnd	A1.51	Transmission
00F	ElectronicGnd	0W1	WCLDoorLock	A1.52	Transmission
00F1	ElectronicGndofA43_A45	0WC	WCLGnd	A1.54	Transmission
00F2	ElectronicGndofA44_A46	1.3	WCLRicon	A1.55	Transmission
00F3	ElectronicGndofA41_A42_A36	1.5	WCLRicon	A1.58	HandLevelSig
0F4	SpeakEasy	1.6	Lugg_door_sw	A1.71	Transmission
00F4	GNDDestinationsign	1.7	Lugg_door_sw	A1.74	Transmission
00F5	ElectronicGndofMuxModules	2.1	ReadingLampsRH	A1.76	Transmission
00F6	IndirectLighting	2.2	HostessChimeSig	A1.77	Transmission
0FB	ElectronicGnd	2.4	HostessChimePwr	A2A.9	Transmission
0FE	GNDFireExt	2.5	USB_WCL	A2A.11	ShifterSignal
0FH	GndLowerWiperMotor	2.6	USB_WCL	A5.B	HandLevelSig
00FH	ElectronicGNDFJB	12VA	12vEqualizer	A9CX1.2	ABS_Trailer_Sig
00FH1	GndDefrostUnit	12VD	Battery_To_SW82A	A9CX1.4	ABSRearAtcSolenoid
00FH2	ElectronicGndofA47_A48	12VD1	12VDTOCB2	A9CX1.5	ABSRearAtcSolenoid
00FR	ElectronicGnd	12VD2	Pwr_Dist_RJB	A9CX1.6	ATCSignal
0FTank	GndCustomer	24V	SpeakEasy	A9CX2.1	ABSSolenoid
0PR	ParcelRack	24VA	24vEqualizer	A9CX2.2	ABSSolenoid
0PR2	ParcelRack	24VD	Battery	A9CX2.3	GndChassisABSSol
0PR3	ParcelRack	24VD1	MasterRelayPwr	A9CX2.4	ABSSolenoid
0PR4	ParcelRack	24VD2	VannerCtr	A9CX2.6	GndChassisABSSol
0PR5	ParcelRack	24VD3	StarterCtr	A9CX2.7	ABSSolenoid
00PR6	SpeakEasy	24VI	24VtoRearVec	A9CX2.9	GndChassisABSSol
00R	GndElectronic	50Rtn3	GndRearClearanceLts	A9CX2.10	ABSSolenoid
0R1	GndCustomer	290A	GndFanClutch	A9CX2.12	GndChassisABSSol
00R1	ElectronicGNDRJB	309	WCL	A9CX2.13	ABSSolenoid
0R2	GndCustomer	313	WCL	A9CX2.16	ABSSolenoid

# CIRCUITS LIST

CircuitID	Description	CircuitID	Description	CircuitID	Description
A9CX2.17	ABSolenoid	A34R.G3	GndFanDrive	A44J2.15	WearFrontWheel
A9CX3.3	ABSSteeringSolenoid	A34R.H3	GndFanDrive	A44RJ1.6	Gnd_Fr_Clearance_Lts
A9CX3.5	ABSSteeringSolenoid	A36JA.10	PulshedCoilR21	A44RJ1.17	kneeling
A9CX3.7	AbsTagSolenoid	A36JA.11	Horn	A44RJ1.18	HvacPassandUpperDefrost
A9CX3.9	AbsTagSolenoid	A36JA.14	BatteryCharger	A44RJ2.2	EntranceCeilingLtGnd
A9CX3.10	AbsTagSolenoid	A36JA.15	24vAccessories	A44RJ2.3	Wiper_Washer
A9CX4.1	ABSPressuresensor	A36JA.17	IgnitionEngineStart	A45J1.1	DashDamper
A9CX4.4	ABSPressuresensor	A36JA.18	PwrdistPRack	A45J1.3	DashDamper
A9CX4.7	ABSSteering&Yawsensor	A36JA.25	BrakeRedundant	A45J1.4	SteeringCTRL
A9CX4.8	ABSSteering&Yawsensor	A36JB.14	Firesuppression	A45J1.7	WitnessPwr
A9CX4.10	ABSSteering&Yawsensor	A38.B	SpeakEasy	A45J1.16	MirrorPwr
A9CX4.11	ABSSteering&Yawsensor	A41J1.1	Preheat	A45J2.1	FootDamper
A10X3.4	Preheat	A41J1.3	EntranceDoorLights	A45J2.4	FootDamper
A10X3.6	BatteryCharger	A41J1.4	WCLRicon	A45J2.7	DriverWdo
A11A.2	Preheat	A41J1.7	PwrdistFJB	A45J2.13	DriverWdo
A14A.A12	SensorGnd	A41J1.13	EngineRunSignal	A45RJ1.17	GndMirrors
A14A.B1	PassengerSensor	A41J1.16	EngineECU	A45RJ1.18	ElectronicGnd
A14A.B2	AccAirPressureSig	A41J1.19	EngineECU	A46J1.4	FrontFlasher
A14A.B13	Trans.RearAirBrake	A41J2.15	PwrDistFJB	A46J1.10	FrontClearanceLts
A14A.B14	Trans.RearAirBrake	A42J1.1	KneelingCtrl.Sol	A46J1.13	FrontMarkers
A14A.B18	AccAirPressureSig	A42J1.3	KneelingDownSol	A46J2.4	Hi-Beam
A14A.B20	Trans.RearAirBrake	A42J1.4	KneelingUpSol	A46J2.7	LowBeam
A14A.B21	Trans.RearAirBrake	A42J1.7	KneelingBuzzer	A46RJ1.17	SignalRtnHeadLtsLH
A17.24V	Battery_Charger_Gnd	A42J1.10	KneelingParkSol	A46RJ1.18	GndFlashersandMarkers
A17.AC.Plugged	ChargerRlyGndSig	A42J1.13	KneelingParkSol	A46RJ2.2	GndFlashersandMarkers
A27.30	ZFsterringControl	A42J1.16	BrakeInterlockValve	A47J1.1	DriverLiq
A27.87A	ZFsterringControl	A42J1.19	BrakeInterlockValve	A47J1.3	DriverHeatValve
A34.A5	PwmFanDrive	A42RJ1.18	Kneeling	A47J1.4	DriverCylinder
A34.B5	PwmFanDrive	A42RJ2.14	KneelingLevel	A47J1.7	LowerWiper1stSpd
A34.C5	PwmFanDrive	A43J1.7	TirePressure	A47J1.10	DoorCloseSol
A34.D5	PwmFanDrive	A43RJ1.18	ElectronicGnd	A47J1.13	EntranceDoor
A34.E5	PwmFanDrive	A44J1.1	UpperDefrostfan	A47J1.16	DoorUnlockSol
A34.F5	PwmFanDrive	A44J1.4	PWRSTAIRFAN	A47J2.1	DefrostunitSpd
A34.G5	PwmFanDrive	A44J1.7	LowerWasherPump	A47J2.7	EntranceDoorLights
A34.H5	PwmFanDrive	A44J1.10	NextStopLight	A47RJ1.6	GndDriverSensor
A34J.E	FanDriveDiag	A44J1.16	RrHi_BuoySol	A47RJ1.17	GndDriverCylinder
A34J.F	FanDriveDiag	A44J1.19	LuggageCmpt.LtsPwr	A47RJ1.18	GndDoorReedSw
A34R.A3	GndFanDrive	A44J1.20	HostessChimeSig	A47RJ2.2	GndEntranceLights
A34R.B3	GndFanDrive	A44J2.1	EntranceDoor	A48J1.7	FrontFlasherRH
A34R.C3	GndFanDrive	A44J2.4	GongSoundGenerator	A48J1.10	FrontFlasherRh
A34R.D3	GndFanDrive	A44J2.7	DriverLt	A48J1.13	Retarder
A34R.E3	GndFanDrive	A44J2.10	GongSoundGenerator	A48J2.1	HighBeamRH
A34R.F3	GndFanDrive	A44J2.13	PwrDistFJB	A48J2.4	LowBeamRH

# CIRCUITS LIST

CircuitID	Description	CircuitID	Description	CircuitID	Description
A48J2.13	FrontFlasherRHSide	A52J2.4	Alternators	A57J1.1	WCLTopLights
A48RJ1.18	GndFogandCorneringLtsRH	A52J2.13	Ignition_Engine_Start	A57J1.3	WCL_Ricon
A48RJ2.2	HeadLampRHRtn	A52RJ1.17	RJB_Gnd	A57J1.4	WCL_Ricon
A49J1.1	ElectricFanSpeed	A52RJ1.18	GndEngineCmpt.Lts	A57J1.10	WCL_Upper_Door_Sol
A49J1.3	ElectricFanSpeed	A53J1.1	ParcelrackA/Csystem	A57J1.13	WCL_Upper_Door_Rel
A49J1.4	TagAxleValveSig	A53J1.3	ParcelrackA/Csystem	A57J1.16	WCL_Door_Rel
A49J2.1	PwrtoExcitationResistor	A53J2.1	IndirectLightLH	A57J1.19	WCL_Prox_Sensor
A49J2.4	Oil_Separator	A53J2.4	ReadingLamps	A57RJ1.18	WCL_Ricon
A49J2.13	Retarder_Sig	A53J2.10	HostessChimePwr	A77.A	VannerCtr
A49RJ1.17	ChassisGnd	A53J2.13	Emergency&aislelights	A77.F	R210_Parcel_Rack_Pwr_dist
A49RJ1.18	OilSeparator	A53RJ1.18	Emerg_Aisle_Lights	A77.H	VannerCtr
A49RJ2.2	GndPulldown	A53RJ2.2	ParcelRack_Vent	A78.3	VannerCtr
A50J1.4	Air_Dryer	A53RJ2.3	GndReadingLamps	A78.4	VannerCtr
A50J1.7	BackupLtandalarm	A54J1.1	Evaporator2ndSpd	A79.3	VannerCtr
A50J1.13	FlashercenterLHSig	A54J1.3	CondensorLow	A80.3	VannerCtr
A50J1.19	FlasherCenterRH	A54J1.4	Preheat	A80.4	VannerCtr
A50J2.1	StopRearLowerLamp	A54J1.7	PassandPRackLiquidValve	A81JB.4	Air_Dryer
A50J2.7	MarkersCenter	A54J1.10	Hvac_Pass	A81JB.6	Vehiculespeed
A50J2.10	TrailerLightsPackage	A54J1.16	A/Cclutch	A81JB.10	SVSensorPwr
A50J2.15	Brake_Wear_Sensor	A54J1.19	EvaporatorPwr	A81JB.15	Control_Ground_Relay
A50RJ1.6	Brake_Wear_Sensor	A54J2.1	ParcelrackA/Csystem	A81JB.16	Air_Dryer
A50RJ1.17	Rear_Lights	A54J2.4	UnloaderRH	A81JB.17	IVSOut
A50RJ1.18	Rear_lights	A54J2.7	Pre-HeatSigRly	A81JB.19	12VPwrIdleValid
A50RJ2.2	GndMarkersandStopLts	A54J2.10	Pass.Cylinder	A81JB.22	GndSensorRtn
A50RJ2.3	Air_Dryer	A54J2.13	SignalToPre-heatrelay	A81JB.23	Air_Dryer
A51J1.4	FlashersRearRH	A54J2.15	TransducerPwr	A81JB.26	Air_Dryer
A51J1.7	CyclopeSignal	A54RJ1.6	SensorGnd	A96.8.BLACK	Tire_Pressure
A51J1.10	MarkersLightsRear	A54RJ1.17	Hvac_Pass	A96.23.RED	Tire_Pressure
A51J1.13	Rr_Flasher_LH	A54RJ1.18	Evaporator	A96.24.BLACK	Tire_Pressure
A51J1.16	Gnd_Service_Brake	A54RJ2.2	RJB_Gnd	A96.25.RED	Tire_Pressure
A51J1.19	WCLTopLightSliding	A54RJ2.3	Hvac_Pass	A96.27.BLACK	Tire_Pressure
A51J2.1	FlashersRearLH	A55J1.1	DriverLt	A96.28.RED	Tire_Pressure
A51J2.4	TransmissionInhibitSig	A55J1.3	Break_Activated_Light	A98.1	Gong
A51J2.7	StopRearUpperLamps	A55J1.4	BatteryNotChargingSig	A98.4	Gong
A51J2.10	FlashersRearRH	A55J1.7	Backup_Warnings	A98.7	Gong
A51RJ1.17	52Rtn2	A55J1.8	A55address	A98.10	Gong
A51RJ1.18	GndDirectLights	A55J1.10	WitnessPwr	A100.3.WHITE	Tire_Pressure
A52J1.1	ElectricFanSpeed	A55J1.12	A55address	A101.3.WHITE	Tire_Pressure
A52J1.3	ElectricFanSpeed	A55J1.13	SW12_Stop_Request	A102.3.WHITE	Tire_Pressure
A52J1.7	RJB_Cmpt_Light	A55J1.16	SW12_Stop_Request	A103.5	Horn
A52J1.10	StarterRelay	A56J1.1	PWRSTAIRFAN	A104.A	WiperParkPwr
A52J1.13	RJB_Fan	A56J1.3	SW123_Bike_Rack	A104.C	Washer_ctrl
A52J2.1	PwrtoExcitationResistor	A56RJ1.6	Hvac_Pass	A104.E	LowerWip1stSpd

# CIRCUITS LIST

CircuitID	Description	CircuitID	Description	CircuitID	Description
A104.F	LowerWip2ndSpd	CanL2	SpareCan	CB62	DCDC_Converter
A130.3	Firesuppression	CB1	24VtoFrontVEC	CB63	DCDC_Converter
A130.4	Firesuppression	CB2	12vEngineEcu	CB73	Engine_ECU
A130.6	Firesuppression	CB3	Evap_Rly_Power	CB90	PowertoEcm
A130.8	Firesuppression	CB4	Volvo_Link	CB91	ECMPower
A130.11	Firesuppression	CB5	24VtoRearVec	CB96	UreaSystem
A131A.C	Firesuppression	CB6	24VtoRearVec	CB99	ECMPower
A131B.A	Firesuppression	CB8	12VtoVECR	CB100	CPC_Supply
A131B.C	Firesuppression	CB9	BattCharger	CB106	PwrtoModuleA50
A137A.4	UreaSystem	CB10	12VtoFrontVec	CB107	PwrtoModuleA51
A137A.7	UreaSystem	CB11	Pwr_Dist_P Rack	CB108	DDDL_RJB_Pwr
A137A.8	UreaSystem	CB13	DCDC_Converter	CB109	PwrtoModuleA50
A137A.24	UreaSystem	CB15	VLink_TGW	CB110	TransmissionPwr
A137A.28	UreaSystem	CB16	12VICustomer	CB112	TransmissionPwr
A137A.40	UreaSystem	CB17	DriverWindoPw	CB113	Tacho_Air_Coolant
A137A.44	UreaSystem	CB18	Mux_Power	CB115V	WCL_Ricon
A137A.49	UreaSystem	CB19	12VDFrontWake-up	CB117	TransmissionPwr
A137A.50	UreaSystem	CB20	Mux_Power	CB119	PwrtoModuleA50
A137A.51	UreaSystem	CB21	12VWUptoA48	CB121	PowerforCustomer
A137A.54	UreaSystem	CB23	12VtoABS	CB122	24VtoMux
A137A.56	UreaSystem	CB24	Entrance_Door	CB123	Battery_Charger_A10
A137A.59	UreaSystem	CB25	Pwr_Dist_FJB_R31	CB124	Battery_Charger_A10
A137A.62	UreaSystem	CB26	A132_Farebox	CB126	PassandPRackPwr
A138.3	UreaSystem	CB29	Pwr_Dist_FJB	CB127	Battery_Charger_R20
A138.12	UreaSystem	CB30	Pwr_Dist_FJB	CB128	Pwr_Dist_RJB
Alt_LL.2	Alternator_Signall	CB33	24WUpFront	CB129	AFSS
Alt_LR.2	ExcitationSignal	CB34	Mux_Power	CB130	A3_Tacho
Alt_UR.2	ExcitationSignal	CB35	Mux_Power	CB131	PowerforCustomer
AltLL	Main_Dist_Batteries	CB36	24VDEng.StartSw83	CB132	AE57_Mux_Pwr
AltLR	AltPower	CB37	24VDtooutsideDoorSw	CB133	AE49_Mux_Pwr
AltUR	Alternator	CB37A	Preheat	CB134	24VtoMux
B85.2	UreaSystem	CB39	24VDCustomer	CB135	24VtoA54
B97.2	UreaSystem	CB44	24WUp_Front	CB136	AE53_Mux_Pwr
B98.2	UreaSystem	CB45	24WUp_To_A47_A48	CB137	LavatoryPwr
B115A.3	DeltaPSignals	CB46	24WUpFront	CB138	Engine_Cmpt_Light
bbbb	Indirect_Lighting	CB47	Mux_Power_A36	CB139	PwrforAlternatorregulator
BLACK	DashBoard_Keypad	CB48	PwrWiperWasher	CB141	CondensorPwr
Black	PwrBatteryCharger	CB50	PwrtoDefrostUnit	CB142	CondensorPwr
BLK	IVN_Clever	CB51	Mux_Power_Dash	CB143	CondensorPwr
BussBar	24VI_To_CB	CB52	24VLogic	CB144	CondensorPwr
CAN1_HI	J1939	CB58	Destination_Signs	CB147	PowerforCustomer
CAN1_LO	J1939	CB60	DCDC_Converter	CB148.B	TransmissionPwr
CanH2	SpareCan	CB61	DCDC_Converter	CB148V	Pwr_Dist_P Rack



# CIRCUITS LIST

CircuitID	Description	CircuitID	Description	CircuitID	Description
CB152.B	TransmissionPwr	GREEN	Destination_sighs	N24	A52Adress
CB201	PwrFanDrive	Green	PwrBatteryCharger	N25	A53Adress
CB202	PwrFanDrive	GRN	IVN_Clever	N26	A53Adress
CB203	PwrFanDrive	IN_SPK+	SpeakEasy	N27	A54Adress
CB204	PwrFanDrive	IN_SPK-	SpeakEasy	N28	A54Adress
CB205	PwrFanDrive	IN_SPK +	Gong	N29	A36Adress
CB206	PwrFanDrive	IN_SPK -	Gong	N56_1	A56Adress
CB207	PwrFanDrive	IVNSTAT	IVN_Clever	N56_2	A56Adress
CB208	PwrFanDrive	L207.1	WCL	N57_1	A57Adress
Cd1	ComputerSignals	L207.3	WCL	N57_2	A57Adress
CF_RS	DCDC_Converter	L350A.B2	Air_Dryer	Out	DCDC_Converter
CTS	MCMDData	Mo65.3	DiagFanDrive	Out+1	DCDC_Converter
Cts	ComputerSignals	Mo67.3	DiagFanDrive	Out+2	DCDC_Converter
D1	Ign-AccSignal	Mo68.3	DiagFanDrive	Out-1	DCDC_Converter
D7	DoorOpenSignal	Mo69.3	DiagFanDrive	Out-2	DCDC_Converter
D9	Preheat	Mo70.3	DiagFanDrive	OUT_SPK	SpeakEasy
D13	Front_Lighting	Mo71.3	DiagFanDrive	OUT_SPK	SpeakEasy
D17	FlashersRearLH	Mo72.3	DiagFanDrive	Pot1	Backlight
D41	24VIgnition	Mo73.3	DiagFanDrive	PPI	WCL_Ricon
D42	24VIgnition	N1	A41Adress	R12	EvaporatorMain
D43	Ignition_Engine_D43_To_R21	N2	A41Adress	R13.30	WCL_Ricon
D55	Indirect_Lighting_D55_To_AE55	N3	A42Adress	R14.30	WCL_Ricon
DL0H	SparesFr-to-RearHarness	N4	A42Adress	R20.87	Hvac_Passenger
DL0HS	SparesCanFrontHarness	N5	A42Adress	R21.87A	12V_Pwr_Dist_FJB
DL0L	SparesFr-to-RearHarness	N6	A42Adress	R21.B	24VIgnition
DL0LS	SparesCanFrontHarness	N7	A44Adress	R23.30	12v_Pwr_Dist_FJB
DL1H	J1939H	N8	A44Adress	R25.87	24VI
DL1L	J1939L	N9	A45Adress	R26.30	PassengerHeatSig
DL2H	BB2	N10	A45Adress	R27.87A	LowerWip.IntSig
DL2L	BB2	N11	A46Adress	R29	24VEnginePreheater
DL3H	DBusSignal	N12	A46Adress	R30.87	12VICustomer
DL3L	DBusSignal	N13	A47Adress	R31.87	12v_Pwr_Dist_FJB
DL7H	EngineSubnet	N14	A47Adress	R34.30	12vEngineEcu
DL7L	EngineSubnet	N15	A48Adress	R36.30	Horn
EI.7	GroundPreheaterRelay	N16	A48Adress	R37.30	ElectricalHorn
EI.18	CoolantLevelGround	N17	A49Adress	R47.87	WheelChairLift
EMS.EB29	fake	N18	A49Adress	R55.30	StairFanSpeedCtr
F101	R1toStarter	N19	A50Adress	R55.87	StairFanSpeedCtr
F126	ParcelrackA/Csystem	N20	A50Adress	R55.87A	StairFanSpeedCtr
F199	FanDrivePwr	N21	A51Adress	R210.B	Pwr_Dist_P Rack
gnd	GroundFuelTank	N22	A51Adress	R_Starter	StarterCtr
GndA	ComputerSignals	N23	A52Adress	RED	Destination_Signs

# CIRCUITS LIST

CircuitID	Description	CircuitID	Description	CircuitID	Description
Res10	Backlight	Se38.1	ABSSensor	Shield_149A	GndShield
RTS	MCMDData	Se38.2	ABSSensor	SHL	Gnd_Shield
Rts	ComputerSignals	Se39.1	ABSSensor	So9.1	A/Cclutch
RX	Tire_Pressure	Se39.2	ABSSensor	spare01	SparesClearanceLts
RxD	ComputerSignals	Se40.1	ABSSensor	spare02	SparesClearanceLts
RxTx	MCMDData	Se40.2	ABSSensor	spare03	SparesClearanceLts
Se1A.B	Air_Filter	Se45.2	Wip.WasherLevel	spare04	SparesClearanceLts
Se2	CyclopeSignal	Se49.B	A/Cclutch	spare05	SparesClearanceLts
Se3.A	Bike_Rack	Se51.2	GroundPreheaterRelay	spare06	SparesClearanceLts
Se11.Sig	FuelLevelSig	Se56.4	WCL_Ricon	spare07	SparesFrontHarness
Se11.Wrn	FuelGaugeWrn	Se62.B	WCL_Se62	spare08	SparesFrontHarness
Se13.B	CoolantLevelSignal	Se63.1	ABSSensor	spare09	SparesFrontHarness
Se14A.B	ThrottlePositionSignal	Se63.2	ABSSensor	spare10	SparesFrontHarness
Se14B.C	IdleValidationSig	Se64.1	ABSSensor	spare20	SparesFr-to-RearHarness
Se18.B	ParkBrakeSig	Se64.2	ABSSensor	spare21	SparesFr-to-RearHarness
Se19_P.D	StopLightSensorSig	Se67.C	ABSPressuresensor	spare22	SparesFr-to-RearHarness
Se19_S.D	StopLightSensorSig	Se69.C	ABSPressuresensor	spare23	SparesFr-to-RearHarness
Se20.B	PassengerSensor	Se76.4	GndDoorReedSw	spare24	SparesFr-to-RearHarness
Se21.2	DriverSensorSig	Se77.C	Brake_Interlock_SE77	spare25	SparesFr-to-RearHarness
Se23.C	TransducerHi-Side	Se78.C	Brake_Interlock_SE78	spare26	SparesFr-to-RearHarness
Se24.2	TranducerLow-Side	Se79.1	KneelingLevel	spare27	SparesFr-to-RearHarness
Se24.3	TranducerLow-Side	Se79.4	KneelingLevel	spare30	SparesFr-to-RearHarness
Se25.2	PassengerTemp	Se83.A	Brake_Wear_Sensor_SE83	spare31	SparesFr-to-RearHarness
Se30.A	EngineDoorOpenSig	Se84.A	Brake_Wear_Sensor_SE84	spare32	SparesFr-to-RearHarness
Se32.A	Transmission	Se85.A	Brake_Wear_Sensor_SE85	spare40	SparesEvap-to-Cond_Harness
Se32.B	Transmission	Se86.A	Brake_Wear_Sensor_SE86	spare41	SparesEvap-to-Cond_Harness
Se33.A	Transmission	Se87.A	Brake_Wear_Sensor_SE87	spare42	SparesEvap-to-Cond_Harness
Se34.A	Transmission	Se88.A	Brake_Wear_Sensor_SE88	spare43	SparesEvap-to-Cond_Harness
Se34.B	Transmission	Se89.A	Coolant_Level	spare50	SparesInteriorHarness
Se35.A	Transmission	Se94.A	WCLRicon	spare51	SparesInteriorHarness
Se35.B	Transmission	Se100.4	WCLGnd	spare60	SparesInteriorHarness
Se37.1	ABSSensor	SHIELD	GndShield	spare61	SparesInteriorHarness
Se37.2	ABSSensor	Shield_149	gndshield	spare62	SparesInteriorHarness

# CIRCUITS LIST

CircuitID	Description	CircuitID	Description	CircuitID	Description
spare63	SparesInteriorHarness	Sw25.3	IndirectLightsSig	Sw85.B2	Mirrors
Spk1_L.B	L_SPEAKER_HARNESS	Sw25.6	DirectLightSwSig	Sw85.B4	Mirrors
Spk1_R.B	FR_SPEAKER_HARNESS_	Sw26.3	ReadingLampSig	Sw96.3	ReadingLampsRH
Spk2_L.B	L_SPEAKER_HARNESS	Sw26.8	WitnessGnd	Sw97.1	ReadingLampsLH
Spk2_R.B	FR_SPEAKER_HARNESS_	Sw27.3	ParcelrackA/Csystem	Sw98.3	HostessChimeSig
Spk3_L.B	L_SPEAKER_HARNESS	Sw27.8	ParcelrackA/Csystem	Sw103.3	Backup_Warnings
Spk3_R.B	FR_SPEAKER_HARNESS_	Sw32.3	DoorInsideSwCloseSig	Sw116	Lugg_door_sw
Spk4_L.B	L_SPEAKER_HARNESS	Sw33.3	DoorOpenSignal	Sw125.2	AutomaticTagUnload
Spk4_R.B	FR_SPEAKER_HARNESS_	Sw34.1	DoorCloseSignal	Sw138.B	FlasherLHSig
Spk5_L.B	L_SPEAKER_HARNESS	Sw34.4	DoorOpenSignal	Sw139.B	FlasherRHSig
Spk5_R.B	FR_SPEAKER_HARNESS_	Sw38.2	DriverWdo	Sw140.B	Brake_Interlock
Spk6_L.B	L_SPEAKER_HARNESS	Sw41.A1	Mirrors	Sw141.B	MarkersSigSw2
Spk6_R.B	FR_SPEAKER_HARNESS_	Sw41.A3	Mirrors	Sw142.5	Brake_Interlock_To_SW142
Spk9_L.B	L_SPEAKER_HARNESS	Sw41.B1	Mirrors	Sw144.B	Horn_Switch
Spk9_R.B	R_SPEAKER_HARNESS_WCL	Sw41.B2	Mirrors	Sw152.B	Firesuppression
Spk10_L.B	L_SPEAKER_HARNESS	Sw41.B4	Mirrors	TWU.3	WCL
Spk10_R.B	R_SPEAKER_HARNESS_WCL	Sw42.2	WCLRemoteCtrl	TX	Tire_Pressure
Spk11_L.B	L_SPEAKER_HARNESS	Sw42.3	WCLRemoteCtrl	TxD	ComputerSignals
Spk11_R.B	R_SPEAKER_HARNESS_WCL	Sw42.4	WCLRemoteCtrl	Unkn	GroundFuelTank
Spk12_L.B	L_SPEAKER_HARNESS	Sw42.5	WCLRemoteCtrl	VECPR1.A	IVN_Clever
Spk12_R.B	R_SPEAKER_HARNESS_WCL	Sw42.6	WCLRemoteCtrl	VECPR1.B	IVN_Clever
SpkIVN+	IVN_Clever	Sw42.7	WCLRemoteCtrl	VECPR1.C	WIFI
SpkIVN-	IVN_Clever	Sw44.1	LuggageDoorOpenSig	VECPR1.D	WIFI
SpkOut+	Speaker	Sw46A.1	WCLUpperDoorSignal	VECPR1.E	Camera
SpkOut-	Speaker	Sw58.3	Ignition_Engine_Start	VECPR1.F	Camera
STO-LOC	WCLRemoteCtrl	Sw58.5	PositionNormalSw58	VECPR1.H	WIFI
Sw2.3	MarkersSigSw2	Sw58.7	StarterRelay	VECPR2.D	Gong
Sw2.6	HeadLtsSig	Sw59.3	RearStartSignal	VECPR4.H	Pwr_Dist_P Rack
Sw4.3	HazardSwSig	Sw64.2	TagSignal	White	PwrBatteryCharger
Sw4.8	WitnessGnd	Sw80.St	StartSigSw80	WHT	IVN_Clever
Sw10A.2	KneelingUpSwSig	Sw81.1	ClusterCtr	WIF1	WIF_Fuel_Filter
Sw13.1	ReadingLampsRH	Sw81.2	ClusterCtr	WIF2	WIF_Fuel_Filter
Sw13.8	WitnessGnd	Sw81.3	ClusterCtr		
Sw14.3	FastIdleSignal	Sw81.4	ClusterCtr		
Sw14.8	WitnessSigSw14	Sw82.4	Ign-AccSignal		
Sw16.3	RetarderSig	Sw82.14	Ign-AccSignal		
Sw16.8	WitnessSigSw16	Sw82A.4	Ign-AccSignal		
Sw17.3	AFSS	Sw83.Ign	24VIgnition		
Sw17.6	AFSS	Sw83.St	StartSigSw80		
Sw20.3	WheelChairLiftSwitch	Sw84.4	GndEngineCmpt.Lts		
Sw20.8	Sw20Gnd	Sw85.A1	Mirrors		
Sw24.3	DriverLtSwSig	Sw85.A3	Mirrors		
Sw24.8	GndWitnessSw24	Sw85.B1	Mirrors		

# BREAKERS LIST

No	Location	Part #	Function	Rating	Page	No	Location	Part #	Function	Rating	Page
CB1	RJBbreakers	563708	24WupFJB	90amp	3,1	CB135V	RJB_VECR	564342	A54Pwr	30amp	5,1
CB2	RJBbreakers	568113	12VD	70amp	3,1	CB136V	RJB_VECR	564342	A53Pwr	30amp	5,1
CB3	RJBbreakers	563708	EvapFan	90amp	3,1	CB137V	RJB_VECR	563647	Spare	5A	5,1
CB5	RJBbreakers	563708	24WupRJB	90amp	3,1	CB138V	RJB_VECR	563647	Englights	5A	5,1
CB6	RJBbreakers	568113	24VD/WCL	70amp	3,1	CB139V	RJB_VECR	563649	Altern	10amp	5,1
CB8	RJBbreakers	563708	12WupRJB	90amp	3,1	CB13V	FJB_VECF	564340	12VDCust	15amp	4,1
CB9	RJBbreakers	563707	BattChrg/UREA	70amp	3,1	CB140V	RJB_VECR	563649	Spare	10amp	5,1
CB10	RJBbreakers	568114	12WupFJB	150amp	3,1	CB141V	RJB_VECR	564399	Mo7Cond	15amp	5,1
CB11	RJBbreakers	568127	Pwr1PRack	50amp	3,1	CB142V	RJB_VECR	564399	Mo8Cond	15amp	5,1
CB13	RJBbreakers	563707	DC/DC/Conv	70amp	3,1	CB143V	RJB_VECR	564399	Mo28Cond	15amp	5,1
CB15	RJBbreakers	568127	12VUltrapcap	50amp	3,1	CB144V	RJB_VECR	564399	Mo27Cond	15amp	5,1
CB100V	RJB_VECR	563649	EngECU	10amp	5,1	CB145V	RJB_VECR	564341	Spare	15amp	5,1
CB105V	RJB_VECR	564399	Spare	20amp	5,1	CB146V	RJB_VECR	563649	Spare	10amp	5,1
CB106V	RJB_VECR	564342	A50Pwr	30amp	5,1	CB147V	RJB_VECR	564340	24WupCust	15amp	5,1
CB107V	RJB_VECR	564342	A51Pwr	30amp	5,1	CB148V	RJB_VECR	564342	PRack	30amp	5,1
CB108V	RJB_VECR	563647	OBDConPwr	5A	5,1	CB149V	RJB_VECR	564399	Uree	15amp	5,1
CB109V	RJB_VECR	563647	Spare	5A	5,1	CB14V	FJB_VECF	563647	Spare	5amp	4,1
CB10V	FJB_VECF	563647	OBD&Clust&Haz	5amp	4,1	CB150V	RJB_VECR	563649	Spare	10amp	5,1
CB110V	RJB_VECR	563649	TransPwr	10amp	5,1	CB151V	RJB_VECR	564340	Spare	15amp	5,1
CB112V	RJB_VECR	563647	Spare	30A	5,1	CB152V	RJB_VECR	563649	Spare	10amp	5,1
CB113V	RJB_VECR	563649	L1&L303Pwr	10amp	5,1	CB15V	FJB_VECF	563647	TGW	5amp	4,1
CB114V	RJB_VECR	564340	Spare	15amp	5,1	CB16V	FJB_VECF	564340	12EngRunCu	15amp	4,1
CB115V	RJB_VECR	563649	Mo38	10amp	5,1	CB17V	FJB_VECF	564342	A43Pwr	30amp	4,1
CB116V	RJB_VECR	564340	Spare	15amp	5,1	CB18V	FJB_VECF	564342	A45Pwr	30amp	4,1
CB117V	RJB_VECR	563649	Spare	10amp	5,1	CB19V	FJB_VECF	564342	A46Pwr	30amp	4,1
CB118V	RJB_VECR	564340	Spare	15amp	5,1	CB20V	FJB_VECF	563647	A55/A15Pwr	5amp	4,1
CB119V	RJB_VECR	563649	RrProxSw	10amp	5,1	CB21V	FJB_VECF	564342	A48Pwr	30amp	4,1
CB11V	FJB_VECF	564464	Horn	20amp	4,1	CB22V	FJB_VECF	563647	Spare	5amp	4,1
CB120V	RJB_VECR	564399	ProFuel	20amp	5,1	CB23V	FJB_VECF	564342	ESP	30amp	4,1
CB121V	RJB_VECR	564340	12WUPCust	15amp	5,1	CB24V	FJB_VECF	564340	Se76Pwr	15amp	4,1
CB122V	RJB_VECR	563649	Equalizer	10amp	5,1	CB25V	FJB_VECF	564340	12VICust	15amp	4,1
CB123V	RJB_VECR	564341	spare	25amp	5,1	CB26V	FJB_VECF	564340	Farebox	15amp	4,1
CB124V	RJB_VECR	564341	Spare	25amp	5,1	CB27V	FJB_VECF	564342	INITSubSyst	30amp	4,1
CB126V	RJB_VECR	563647	R29/So11	5A	5,1	CB295V	Parcel_Rack_VECPR	563647	24VDismIvN/MotorolaAudio	5amp	5,2
CB127V	RJB_VECR	564340	WaterPump	15amp	5,1	CB296V	Parcel_Rack_VECPR	563647	24VDismFareboxRelay	5amp	5,2
CB128V	RJB_VECR	564342	24VDFJB	30amp	5,1	CB297V	Parcel_Rack_VECPR	563647	24VDismMotorolaRelay	5amp	5,2
CB129V	RJB_VECR	564340	OilSep	15amp	5,1	CB299V	Parcel_Rack_VECPR	563647	24WupRelay12VWup	5amp	5,2
CB12V	FJB_VECF	564340	Spare	15amp	4,1	CB29V	FJB_VECF	563649	Shutdown	10amp	4,1
CB130V	RJB_VECR	564340	Tachometer	15amp	5,1	CB300V	Parcel_Rack_VECPR	563647	24VDismBCIS/CardValidator	5amp	5,2
CB131V	RJB_VECR	563647	24VDCust	5A	5,1	CB301V	Parcel_Rack_VECPR	563649	24VDismCamera	10amp	5,2
CB132V	RJB_VECR	563647	A57Pwr	5A	5,1	CB302V	Parcel_Rack_VECPR	563649	24VDismITS	10amp	5,2
CB133V	RJB_VECR	564342	A49Pwr	30amp	5,1	CB303V	Parcel_Rack_VECPR	563647	24VDismWIFI	5amp	5,2
CB134V	RJB_VECR	564342	A52Pwr	30amp	5,1	CB304V	Parcel_Rack_VECPR	563649	24VDismInfotainment	10amp	5,2

# BREAKERS LIST

No	Location	Part #	Function	Rating	Page	No	Location	Part #	Function	Rating	Page
CB305V	Parcel_Rack_VECPR	564340	24VDismFarebox	15amp	5,2	CB54V	FJB_VECF	564340	Spare	15amp	4,2
CB306V	Parcel_Rack_VECPR	563647	Spare	5amp	5,2	CB55V	FJB_VECF	563649	Spare	10amp	4,2
CB307V	Parcel_Rack_VECPR	563647	Spare	5amp	5,2	CB56V	FJB_VECF	564340	Spare	15amp	4,2
CB308V	Parcel_Rack_VECPR	563647	Spare	5amp	5,2	CB57V	FJB_VECF	563649	Spare	10amp	4,2
CB30V	FJB_VECF	563647	OBDCon	5amp	4,1	CB58V	FJB_VECF	564340	DestSigns	15amp	4,2
CB310V	Parcel_Rack_VECPR	563647	24VIBCIS/CardValidator	5amp	5,2	CB60V	Rear_Seat	564342	USB	30amp	40,2
CB311V	Parcel_Rack_VECPR	563649	24VICamera/backUp	10amp	5,2	CB61V	Rear_Seat	564342	USB	30amp	40,2
CB312V	Parcel_Rack_VECPR	563649	24VIITS	10amp	5,2	CB62V	Rear_Seat	564342	USB	30amp	40,2
CB313V	Parcel_Rack_VECPR	563647	24VIWIFI	5amp	5,2	CB63V	Rear_Seat	564342	USB	30amp	40,2
CB314V	Parcel_Rack_VECPR	563649	24VIInfotainment	10amp	5,2	CB73V	RJB_VECR	564399	EngECU	20amp	5,1
CB315V	Parcel_Rack_VECPR	564340	24VIDestSigns	15amp	5,2	CB90V	RJB_VECR	564399	UreaSys	20amp	5,1
CB316V	Parcel_Rack_VECPR	563647	Spare	5amp	5,2	CB91V	RJB_VECR	564399	EngECU	20amp	5,1
CB317V	Parcel_Rack_VECPR	563647	Spare	5amp	5,2	CB95V	FJB_VECF	563647	Spare	5amp	4,2
CB320V	Parcel_Rack_VECPR	564340	24WupFarebox	15amp	5,2	CB96V	RJB_VECR	564399	Spare	20amp	5,1
CB321V	Parcel_Rack_VECPR	563647	24WupDestSigns	5amp	5,2	CB99V	RJB_VECR	564342	EngECU	30amp	5,1
CB322V	Parcel_Rack_VECPR	563647	24WupPassCounter	5amp	5,2						
CB323V	Parcel_Rack_VECPR	563647	24WupEthernetSwitch	5amp	5,2						
CB324V	Parcel_Rack_VECPR	563647	Spare	5amp	5,2						
CB325V	Parcel_Rack_VECPR	563647	Spare	5amp	5,2						
CB330V	Parcel_Rack_LH	563647	12VControlHead	5amp	5,2						
CB331V	Parcel_Rack_LH	563647	Spare	5amp	5,2						
CB332V	Parcel_Rack_LH	564341	12VDismRadio12Wup	25amp	5,2						
CB333V	Parcel_Rack_LH	564341	12VDismRadio	25amp	5,2						
CB33V	FJB_VECF	563647	A41Pwr	5amp	4,2						
CB34V	FJB_VECF	563647	A42Pwr	5amp	4,2						
CB35V	FJB_VECF	563647	MCMPwr	5amp	4,2						
CB36V	FJB_VECF	563647	Ign.Sw	5amp	4,2						
CB37V	FJB_VECF	563647	Haz/ExtDoorSw	5amp	4,2						
CB39V	FJB_VECF	564340	24VDCust	15amp	4,2						
CB40V	FJB_VECF	564340	Spare	15amp	4,2						
CB41V	FJB_VECF	563647	Spare	5A	4,2						
CB42V	FJB_VECF	563649	Spare	10amp	4,1						
CB43V	FJB_VECF	564399	Spare	20amp	4,1						
CB44V	FJB_VECF	564342	A44Pwr	30amp	4,2						
CB45V	FJB_VECF	564342	A47Pwr	30amp	4,2						
CB46V	FJB_VECF	563647	Gateway	5amp	4,2						
CB47V	FJB_VECF	563647	MCM	5amp	4,2						
CB48V	FJB_VECF	564399	Wipers	20amp	4,2						
CB4V	FJB_VECF	563647	Spare	5amp	4,2						
CB50V	FJB_VECF	564342	Defrost	30amp	4,2						
CB51V	FJB_VECF	563647	A56Pwr	5amp	4,2						
CB52V	FJB_VECF	563647	Spare	5amp	4,2						
CB53V	FJB_VECF	563649	Spare	10amp	4,2						

# CONNECTORS LIST

No	Location	Part #	Gender	No	Location	Part #	Gender
A1	RJB	563975	male	A78	RJB	6E+05	female
A2	FJB	563984	male	A79	RJB	6E+05	female
A3.A	dash	565910	male	A80	EngineCmpt.	6E+05	female
A3.B	Dash	565908	male	A81.JA	FJB	6E+05	male
A3.C	Dash	565909	male	A81.JB	FJB	6E+05	male
A5	Service_Cmpt	562428	female	A81.JC	FJB	6E+05	male
A6	Engine_Cmpt	562427	male	A83	FJB	6E+05	female
A7	Rear_Axle_Cmpt	563979	male	A96	FJB	6E+05	male
A9.Cx1	FJB	564041	female	A97.A1	Dash	6E+05	male
A9.Cx2	FJB	563678	male	A97.A2	Dash	6E+05	male
A9.Cx3	FJB	564037	male	A97.A3	Dash	6E+05	male
A9.Cx4	FJB	564038	female	A98	Upperfront	6E+05	male
A14A.A	Dash	562766	male	A99	FJB	6E+05	male
A14A.B	Dash	562767	male	A100	FrontAxle	6E+05	male
A14A.C	Dash	562765	male	A101	RearRH Axel	6E+05	male
A15	Dash	562464	male	A102	RearLH Axel	6E+05	male
A18.J1	FJB	562794	male	A103	Dash	6E+05	female
A18.J2	FJB	562650	male	A104	Dash	6E+05	female
A24.A	RH_Console	561890	male	A107	Parcel_rack_LH	6E+05	male
A24.B	RH_Console	561566	female	A108.P1	Parcel_Rack_LH	6E+05	male
A27	Service_Cmpt	562929	male	A108.P2	Parcel_Rack_LH	6E+05	male
A28	Service_Cmpt	562928	male	A110.A	InterFrRoof	6E+05	female
A34.7	Rad_Cmpt	564258	male	A111	Entrancedoor	6E+05	male
A34.J	Rad_Cmpt	568118	male	A112.X1	Parcel_Rack	bidon	male
A34.K	Rad_Cmpt	564270	male	A112.X2	Parcel_Rack	bidon	male
A34.L	Rad_Cmpt	564269	male	A112.X3	Parcel_Rack	bidon	male
A36.JA	FJB	562767	male	A112.X4	Parcel_Rack	6E+05	male
A36.JB	FJB	562765	male	A112.X5	Parcel_Rack	bidon	male
A36.JC	FJB	562957	male	A112.X6	Parcel_Rack	bidon	male
A37.JA	FJB	562767	male	A112.X7	Parcel_Rack	bidon	male
A37.JB	FJB	562765	male	A113.X1	Parcel_Rack	6E+05	male
A37.JC	FJB	562957	male	A113.X2	Parcel_Rack	bidon	male
A69L.A	P.RackLH	563025	male	A113.X3	P.RackLH	6E+05	male
A69L.B2	P.RackLH	bidon	male	A113.X4	P.RackLH	bidon	male
A69L.B4	P.RackLH	bidon	male	A130.	Driver_Area	6E+05	male
A69L.C	P.RackLH	bidon	male	A130.J1	3rd_LH_Lugg_Cmpt	6E+05	male
A69R.A	P.RackLH	563025	male	A130.J2	3rd_LH_Lugg_Cmpt	6E+05	male
A69R.B1	P.RackLH	bidon	male	A130.J4	3rd_LH_Lugg_Cmpt	6E+05	male
A69R.B2	P.RackLH	bidon	male	A131.A	Engine_Cmpt	6E+05	male
A69R.B3	P.RackLH	bidon	male	A131.B	Engine_Cmpt	6E+05	female
A69R.B4	P.RackLH	bidon	male	A132.A	Driver_Area	6E+05	male
A69R.C	P.RackLH	bidon	male	A132.B	Driver_Area	6E+05	female
A77	RJB	564547	male	A134.A	Engine_Cmpt	6E+05	male

# CONNECTORS LIST

No	Location	Part #	Gender	No	Location	Part #	Gender
A134.B	Engine_Cmpt	561781	female	AE51.J2	RJB	564037	female
A135.A	Engine_Cmpt	561782	male	AE51.J3	RJB	565957	male
A135.B	Engine_Cmpt	561781	female	AE52.J1	RJB	563679	male
A136.A	Engine_Cmpt	561782	male	AE52.J2	RJB	564037	female
A136.B	Engine_Cmpt	561781	female	AE52.J3	RJB	565957	male
A138	CondensorCmpt.	563787	male	AE53.J1	RJB	563679	male
A139.A	3rd_LH_Lugg_Cmpt	561782	male	AE53.J2	RJB	564037	female
A139.B	3rd_LH_Lugg_Cmpt	561781	female	AE53.J3	RJB	565957	male
A139.C	3rd_LH_Lugg_Cmpt	565158	female	AE54.J1	EvaporatorCmpt.	563679	male
A140	Driver_Area	563226	male	AE54.J2	EvaporatorCmpt.	564037	female
A160.A	LuggCmpt	562477	male	AE54.J3	CondensorCmpt.	565957	male
A160.B	LuggCmpt	562884	female	AE55.J1	Dash	563679	male
AE41.J1	FJB	563679	male	AE55.J2	Dash	564037	female
AE41.J2	FJB	564037	female	AE55.J3	Dash	564004	male
AE41.J3	FJB	564004	male	AE56.J1	Dash	563679	male
AE42.J1	FJB	563679	male	AE56.J2	Dash	564037	male
AE42.J2	FJB	564037	female	AE56.J3	Dash	564004	male
AE42.J3	FJB	564004	male	AE57.J1	WCLCmpt.	563679	male
AE43.J1	FJB	563679	male	AE57.J2	WCLCmpt.	564037	male
AE43.J2	FJB	564037	male	AE57.J3	WCLCmpt.	564004	male
AE43.J3	FJB	565957	male	Alt_LR.A	EngineCmpt.	563746	female
AE44.J1	FJB	563679	male	Alt_LR.B	EngineCmpt.	560815	female
AE44.J2	FJB	564037	female	Alt_LR.C	EngineCmpt.	564469	female
AE44.J3	FJB	565957	male	Alt_UR.A	EngineCmpt.	563746	female
AE45.J1	FJB	563679	male	Alt_UR.B	EngineCmpt.	560815	female
AE45.J2	FJB	564037	female	Alt_UR.C	EngineCmpt.	564469	female
AE45.J3	FJB	565957	male	AltLL.A	EngineCmpt.	563746	female
AE46.J1	FJB	563679	male	AltLL.B	EngineCmpt.	560815	female
AE46.J2	FJB	564037	female	AltLL.C	EngineCmpt.	564469	female
AE46.J3	FJB	565957	male	B85	EngineCmpt	563815	male
AE47.J1	RHConsole	563679	male	B96	EngineCmpt	563821	male
AE47.J2	RHConsole	564037	female	B96B	EngineCmpt	563823	male
AE47.J3	RHConsole	565957	male	B97	EngineCmpt	563816	male
AE48.J1	RHConsole	563679	male	B98	EngineCmpt	563817	male
AE48.J2	RHConsole	564037	female	B99	EngineCmpt	563815	male
AE48.J3	RHConsole	565957	male	B115A	EngineCmpt.	564226	male
AE49.J1	RJB	563679	male	B142C	EngineCmpt.	563793	male
AE49.J2	RJB	564037	male	B310	EngineCmpt.	565967	male
AE49.J3	RJB	565957	male	C.243	ServiceCmpt.	562789	male
AE50.J1	RJB	563679	male	C.243	ServiceCmpt.	565131	female
AE50.J2	RJB	564037	male	C1	FJB	563589	male
AE50.J3	RJB	565957	male	C1	FJB	563590	female
AE51.J1	RJB	563679	male	C1A	FJB	561611	male

# CONNECTORS LIST

No	Location	Part #	Gender	No	Location	Part #	Gender
C1A	FJB	561610	female	C18	FJB	561986	male
C1B	Parcel_Rack_LH	561611	male	C18	FJB	561987	female
C1B	Parcel_Rack_LH	561610	female	C19	RJB	561986	male
C1S	FJB	563589	male	C19	RJB	561987	female
C1S	FJB	563590	female	C20A	AFSS	562485	male
C2	Service_Cmpt	563580	male	C20A	AFSS	562486	female
C2	Service_Cmpt	563581	female	C20B	Evap_Cmpt	562485	male
C2A	FJB	563580	male	C20B	Evap_Cmpt	562486	female
C2A	FJB	563581	female	C23	Evap.Cmpt.	564034	male
C2bb	FJB	564034	male	C23	Evap.Cmpt.	564035	female
C2bb	FJB	564035	female	C24_plug	Evap_Cmpt	561690	male
C3_plug	RJB	563589	male	C24_sock	Evap_Cmpt	561566	female
C3_socket	RJB	563590	female	C25	Parcel_Rack_LH	561550	male
C3S	RJB	563593	male	C25	Parcel_Rack_LH	561667	female
C3S	RJB	563590	female	C25.	Parcel_Rack_LH	561669	male
C4	FJB	563580	male	C25.	Parcel_Rack_LH	561670	female
C4	FJB	563581	female	C25A	ParcalrackLH	561515	male
C5	FJB	563589	male	C25A	ParcelRackLH	561552	female
C5	FJB	563590	female	C25A.	ParcalrackLH	561669	male
C5S	FJB	563589	male	C25A.	ParcalrackLH	561670	female
C5S	FJB	563590	female	C26	UreaCmpt.	563226	male
C6	FJB	563582	male	C26	UreaCmpt.	563613	female
C6	FJB	563583	female	C26A	UreaCmpt.	568110	male
C9	RJB	561986	male	C26A	UreaCmpt.	568109	female
C9	RJB	561987	female	C26B	UreaCmpt.	563227	male
C10	Engine_Cmpt	562477	male	C26B	UreaCmpt.	563614	female
C10	Engine_Cmpt	562479	female	C29	3rd_Lugg_Cmpt	563651	male
C11	Service_Cmpt	563580	male	C29	3rd_Lugg_Cmpt	563652	female
C11	Service_Cmpt	563581	female	C30	3rd_Lugg_Cmpt	561710	male
C12	Engine_Cmpt	562581	male	C30	3rd_Lugg_Cmpt	561709	female
C12	Engine_Cmpt	562583	female	C31W	3rdLuggCmpt.	563227	male
C13_plug	RH_Console	563589	male	C31W	3rdLuggCmpt.	563614	female
C13_socket	RH_Console	563590	female	C32W	WCLCmpt.	561640	male
C13S	RH_Console	563589	male	C32W	WCLCmpt.	561639	female
C13S	RH_Console	563590	female	C33	WCLCmpt.	564034	male
C14	RJB	561986	male	C33	WCLCmpt.	564035	female
C14	RJB	561987	female	C33W	WCLCmpt.	562477	male
C15A	EvapCmpt	568110	male	C33W	WCLCmpt.	562479	female
C15A	EvapCmpt	568109	female	C34	RH_Console	561986	male
C16	RJB	561577	male	C34	RH_Console	561987	female
C16	RJB	561605	female	C35	WCLdoor	562485	male
C17	RJB	560195	male	C35	WCLdoor	562486	female
C17	RJB	560169	female	C36	FJB	561986	male



# CONNECTORS LIST

No	Location	Part #	Gender	No	Location	Part #	Gender
C36	FJB	561987	female	C62	Fr_Service_Door	562566	male
C37	Parcel_Rack_LH	562557	male	C62	Fr_Service_Door	562565	female
C37	Parcel_Rack_LH	562558	female	C64	EngineCmpt.	568110	male
C37.	Parcel_Rack_LH	561734	male	C64	EngineCmpt.	568109	female
C37.	Parcel_Rack_LH	561735	female	C68	P.RackLH	561646	male
C38	ParcelRackLH	562555	male	C68	P.RackLH	561644	female
C38	ParcelRackLH	562556	female	C70	FJB	561646	male
C38.	ParcelRackLH	561734	male	C70	FJB	561645	female
C38.	ParcelRackLH	561735	female	C70B	FJB	561710	male
C39A	Engine_Cmpt	561782	male	C70B	FJB	561989	female
C39A	Engine_Cmpt	561781	female	C71	FJB	561646	male
C40	Dash	562485	male	C71	FJB	561645	female
C40	Dash	562486	female	C72	FJB	561646	male
C44_plug	FJB	561577	male	C72	FJB	561645	female
C44_socket	FJB	561605	female	C74	FJB	561710	male
C45	FJB	561643	male	C74	FJB	561989	female
C45	FJB	561642	female	C77	FJB	562350	male
C46	WCLCmpt.	564228	male	C77	FJB	563764	female
C46	WCLCmpt.	564229	female	C79	RJB	561986	male
C50	RJB	563931	male	C79	RJB	561987	female
C50	RJB	563930	female	C81_plug	1stLuggCmpt.	562477	male
C51	Engine_Cmpt	561932	male	C81_socket	1stLuggCmpt.	562479	female
C51	Engine_Cmpt	560933	female	C82	1stLuggCmpt.	562581	male
C52	Evap.Cmpt.	563618	male	C82	2ndLuggCmpt.	562583	female
C52	Evap.Cmpt.	563616	female	C83_plug	2ndLuggCmpt.	562477	male
C54	EngineCmpt.	563226	male	C83_socket	2ndLuggCmpt.	562479	female
C54	EngineCmpt.	563613	female	C84_plug	2ndLuggCmpt.	562477	male
C54A	EngineCmpt.	568110	male	C84_socket	2ndLuggCmpt	562479	female
C54A	EngineCmpt.	568109	female	C85_plug	3rdLuggCmpt.	562477	male
C54B	EngineCmpt.	563589	male	C85_socket	3rdLuggCmpt.	562479	female
C54B	EngineCmpt.	563590	female	C86	3rdLuggCmpt.	563618	male
C56	3rd_LH_Lugg_Cmpt	561643	male	C86	3rdLuggCmpt.	563616	female
C56	3rd_LH_Lugg_Cmpt	561642	female	C87	Engine_Cmpt	562485	male
C57	3rd_LH_Lugg_Cmpt	561782	male	C87	Engine_Cmpt	562486	female
C57	3rd_LH_Lugg_Cmpt	561781	female	C88	WCLCmpt.	563227	male
C57A	Engine_Cmpt	561690	male	C88	WCLCmpt.	563614	female
C57A	Engine_Cmpt	561566	female	C91	RJB	564619	male
C58	CondensorCmpt.	564567	male	C91	RJB	562282	female
C58	CondensorCmpt.	564568	female	C92A	EngineCmpt.	563226	male
C59	LuggCmpt.	561646	male	C92A	EngineCmpt.	563613	female
C59	LuggCmpt.	561645	female	C92B	EngineCmpt.	562581	male
C61	Fr_Service_Door	561669	male	C92B	EngineCmpt.	562583	female
C61	Fr_Service_Door	561670	female	C92C	EngineCmpt.	562581	male

# CONNECTORS LIST

No	Location	Part #	Gender	No	Location	Part #	Gender
C92C	EngineCmpt.	562583	female	C171	LH_Console	561646	male
C94_plug	FJB	563589	male	C171	LH_Console	561645	female
C94_socket	FJB	563590	female	C175	RJB	563226	male
C95	FJB	561646	male	C175	RJB	563613	female
C95	FJB	561645	female	C193_r	RJB	563589	male
C96	FJB	561643	male	C193_s	RJB	563590	female
C96	FJB	561642	female	C194	FJB	563589	male
C97	FJB	561643	male	C194	FJB	563590	female
C97	FJB	561642	female	C206	Parcel_Rack_RH	562503	male
C98	2nd_LH_Lugg_Cmpt	562581	male	C206	Parcel_Rack_RH	562507	female
C98	2nd_LH_Lugg_Cmpt	562583	female	C207	Parcel_Rack_LH	562503	male
C99	2nd_RH_Lugg_Cmpt	562581	male	C207	Parcel_Rack_LH	562507	female
C99	2nd_RH_Lugg_Cmpt	562583	female	C213	Parcel_Rack_LH	561515	male
C100	EvapCmpt.	562477	male	C213	Parcel_Rack_LH	561552	female
C100	EvapCmpt.	562479	female	C223	FJB	563227	male
C100S	EvapCmpt.	562477	male	C223	FJB	563614	female
C100S	EvapCmpt.	562479	female	C226	FJB	562650	male
C101	Service_Cmpt	561690	male	C226	FJB	562649	female
C101	Service_Cmpt	561566	female	C227	FJB	562650	male
C102A	CondensorCmpt.	563226	male	C227	FJB	562649	female
C102A	CondensorCmpt.	563613	female	C229	Dash	561782	male
C104S_plug	LuggCmpt.	563589	male	C229	Dash	561781	female
C104S_socket	LuggCmpt.	563590	female	C230	FrontInterRoof	562477	male
C110	PneumaticPanel	568110	male	C230	FrontInterRoof	562479	female
C110	PneumaticPanel	568109	female	C231	FJB	563409	male
C115	FrInterRoof	561690	male	C231	FJB	563410	female
C115	FrInterRoof	561566	female	C242	Service_Cmpt	562789	male
C116	FrInterRoof	561611	male	C242	Service_Cmpt	565131	female
C116	FrInterRoof	561610	female	C243	ServiceCmpt.	563347	male
C117	Parcel_Rack_LH	561690	male	C243	ServiceCmpt.	563180	female
C117	Parcel_Rack_LH	561566	female	C259	LuggCmpt	561637	male
C119	EngineDoor	568110	male	C259	LuggCmpt	561636	female
C119	EngineDoor	568109	female	C266	Parcelrack	561782	male
C121	EngineDoor	563347	male	C266	Parcelrack	561781	female
C121	EngineDoor	563180	female	C267	Parcelrack	561782	male
C122	EngineDoor	568118	male	C267	Parcelrack	561781	female
C122	EngineDoor	562531	female	C279	Service_Cmpt	562477	male
C144	ParcelRackJB	560852	male	C279	Service_Cmpt	562479	female
C144	ParcelRackJB	560851	female	C284	Parcel_Rack_LH	561247	male
C152	Cond_Cmpt	561611	male	C284	Parcel_Rack_LH	561248	female
C152	Cond_Cmpt	561610	female	C284_1	Parcel_Rack_LH	561247	male
C158	CondCmpt.	562477	male	C284_1	Parcel_Rack_LH	561248	female
C158	CondCmpt.	562479	female	C284_2	Parcel_Rack_LH	561247	male

# CONNECTORS LIST

No	Location	Part #	Gender	No	Location	Part #	Gender
C284_2	Parcel_Rack_LH	561248	female	C577A	Parcel_Rack	562006	male
C284_3	Parcel_Rack_LH	561247	male	C577A	Parcel_Rack	560908	female
C284_3	Parcel_Rack_LH	561248	female	C577AA	ParcelRack	562006	male
C284_4	Parcel_Rack_LH	561247	male	C577AA	ParcelRack	560908	female
C284_4	Parcel_Rack_LH	561248	female	C578	ParcelRackJB	562503	male
C284_5	Parcel_Rack_LH	561247	male	C578	ParcelRackJB	562507	female
C284_5	Parcel_Rack_LH	561248	female	C579	P.RackLH	562549	male
C349	Engine_Cmpt	565170	male	C579	P.RackLH	562550	female
C350	Engine_Cmpt	565170	male	C_ALT	EngineCmpt.	562581	male
C355	RJB	563582	male	C_ALT	EngineCmpt.	562583	female
C355	RJB	563583	female	C_ALT3	EngineCmpt.	562477	male
C356	ParcelRackJB	561710	male	C_ALT3	EngineCmpt.	562479	female
C356	ParcelRackJB	561709	female	C_BCIS_BHS	P.RackLH	561643	male
C357	P.RackJCB	564294	male	C_BCIS_BHS	P.RackLH	561641	female
C357	P.RackJCB	564295	female	C_BCIS_IFU	P.RackLH	562650	male
C358	P.RackLH	566033	male	C_BCIS_IFU	P.RackLH	562649	female
C358	P.RackLH	566034	female	C_BCIS_ODK	P.RackLH	562650	male
C380A	Dash	564222	male	C_BCIS_ODK	P.RackLH	562649	female
C380A	Dash	564224	female	C_BCIS_PWR	P.RackLH	561550	male
C397	RJB	562285	male	C_BCIS_PWR	P.RackLH	561667	female
C397	RJB	562282	female	C_BCIS_RDR	P.RackLH	565940	male
C463	EngineCmpt	568112	male	C_BCIS_SIG	P.RackLH	561690	male
C463	EngineCmpt	568111	female	C_BCIS_SIG	P.RackLH	561566	female
C464A	RJB	564222	male	C_BCIS_SW	P.RackLH	561637	male
C464A	RJB	564224	female	C_BCIS_SW	P.RackLH	561636	female
C465	Parcelrack	562581	male	C_BCIS_SW1	P.RackLH	561637	male
C465	Parcelrack	562583	female	C_BCIS_SW1	P.RackLH	561636	female
C466	LH_Consol	562503	male	C_Bike_Se	Front_Axle	562901	male
C466	LH_Consol	562507	female	C_Bike_Se	Front_Axle	562902	female
C574	P.RackRH	562549	male	C{EIF	Engine_Cmpt	563135	male
C574	P.RackRH	562550	female	C{EIF	Engine_Cmpt	563134	female
C575	ParcelRackRH	562503	male	C_Foot	FJB	563347	male
C575	ParcelRackRH	562507	female	C_Foot	FJB	563180	female
C576	Parcel_Rack_RH	561515	male	C_INV1	ParcelRack	562337	male
C576	Parcel_Rack_RH	561552	female	C_INV1	ParcelRack	562338	male
C576A	Parcel_Rack_RH	561515	male	C_INV2_1	ParcelRack	562337	male
C576A	Parcel_Rack_RH	561552	female	C_INV2_1	ParcelRack	562338	male
C576B	Parcel_Rack_RH	562006	male	C_INV2_2	ParcelRack	562337	male
C576B	Parcel_Rack_RH	560908	female	C_INV2_2	ParcelRack	562338	female
C576BB	ParcelRack	562006	male	C_INV3	ParcelRack	562337	male
C576BB	ParcelRack	560908	female	C_INV3	ParcelRack	562338	female
C577	Parcel_Rack	561515	male	C_JP_FBOX	Parcel_Rack_LH	561782	male
C577	Parcel_Rack	561552	female	C_JP_FBOX	Parcel_Rack_LH	561781	female

# CONNECTORS LIST

No	Location	Part #	Gender	No	Location	Part #	Gender
C_JP_Rad	Parcel_Rack_LH	561782	male	CIND1.A	ParcelRack	560908	female
C_JP_Rad	Parcel_Rack_LH	561781	female	CIND1.B	ParcelRack	560908	female
C_Mo9_p	Evap_Cmpt	561577	male	CIND_1.A	ParcelRack	560908	female
C_Mo9_s	Evap_Cmpt	561605	female	CIND_1.B	ParcelRack	560908	female
C_MVIEW	ParcelRackLH	563227	male	CINDWC-1.A	ParcelRack	560908	female
C_MVIEW	ParcelRackLH	563614	female	CINDWC-1.B	ParcelRack	560908	female
C_MVIEW	ParcelRackLH	39-01-214	male	CJUP1	Dash	560898	male
C_MVIEW	ParcelRackLH	39-01-214	female	CJUP1	Dash	560900	female
C_MVIEW	ParcelRackLH	562779	male	CJUP4	Dash	560898	male
C_MVIEW	ParcelRackLH	562465	male	CJUP4	Dash	560900	female
C_MVIEW	ParcelRackLH	562842	male	CJUR1	Dash	562485	male
C_USB1_f	Passenger_Area	561566	female	CJUR1	Dash	562486	female
C_USB1_f	Passenger_Area	561690	male	CJUR2	Dash	561577	male
C_USB1_l	Passenger_Area	561566	female	CJUR2	Dash	561605	female
C_USB1_l	Passenger_Area	561690	male	CL350	Cond_Cmpt	562251	male
C_USB1_m	Passenger_Area	563025	male	CP1	PassengerArea	561782	male
C_USB1_f	Passenger_Area	561566	female	CP1	PassengerArea	561781	female
C_USB1_f	Passenger_Area	561690	male	CP2	PassengerArea	561782	male
C_USB1_f	Passenger_Area	561566	female	CP2	PassengerArea	561781	female
C_USB1_f	Passenger_Area	561690	male	CP3	PassengerArea	561782	male
C_USB1_s	Passenger_Area	561566	female	CP3	PassengerArea	561781	female
C_USB1_s	Passenger_Area	561690	male	CP4	PassengerArea	561782	male
C_USB2	Passenger_Area	563025	male	CP4	PassengerArea	561781	female
C_USB_1	Passenger_Area	563025	male	CP_LH	RrSeat	563601	male
C_USB_F.	Passenger_Area	561566	female	CP_LH	RrSeat	563600	female
C_USB_F.	Passenger_Area	561690	male	CP_RH	RrSeat	563601	male
C_USB_LH	RrSeat	561690	male	CP_RH	RrSeat	563600	female
C_USB_LH	RrSeat	561566	female	CPUP2	Dash	560898	male
C_USB_R.	Passenger_Area	561566	female	CPUP2	Dash	560900	female
C_USB_R.	Passenger_Area	561690	male	CPUP3	Dash	560898	male
C_USBF_f	Passenger_Area	561566	female	CPUP3	Dash	560900	female
C_USBF_f	Passenger_Area	561690	male	CPUP5	Dash	560898	male
C_USBR_f	Passenger_Area	561566	female	CPUP5	Dash	560900	female
C_USBR_f	Passenger_Area	561690	male	CRadio	P.RackLH	565922	male
CB_PR	P.RackLH	564238	male	CSw34	FrontRH	563815	male
CB_RS	RJBBreakersPanel	564238	male	CSw34	FrontRH	563832	female
CCust	RJB	562477	male	CSX1	EngineCmpt.	563135	male
CCust	RJB	562479	female	CSX1	EngineCmpt.	563134	female
CF_RS	Rear_Seat	564238	male	CSX3	EngineCmpt.	563135	male
CIND-1.A	ParcelRack	560908	female	CSX3	EngineCmpt.	563134	female
CIND-1.B	ParcelRack	560908	female	CT	FrontAxle	563869	female
CIND-2.A	ParcelRack	560908	female	CT_Fr	FrontAxle	560167	male
CIND-2.B	ParcelRack	560908	female	CT_Fr	FrontAxle	560159	female

# CONNECTORS LIST

No	Location	Part #	Gender	No	Location	Part #	Gender
CT_Rr	RJB	560167	male	L38	Parcel_Rack	560898	male
CT_Rr	RJB	560159	female	L39	Parcel_Rack	560898	male
CVIP	Dash	568085	male	L40	Parcel_Rack	560898	male
CXC1	Service_Cmpt	562477	male	L41	Parcel_Rack	560898	male
CXC1	Service_Cmpt	562479	female	L42	Parcel_Rack	560898	male
EIA	EngineCmpt.	563739	male	L43	Parcel_Rack	560898	male
L.21	FrontRoof	560605	female	L44	Parcel_Rack	560898	male
L.22	FrontRoof	560605	female	L45	Parcel_Rack	560898	male
L.23	FrontRoof	560605	female	L46	Parcel_Rack	560898	male
L.24	FrontRoof	560605	female	L47	Parcel_Rack	560898	male
L.25	FrontRoof	560605	female	L48	Parcel_Rack	560898	male
L.26	FrontRoof	560605	female	L49	Parcel_Rack	560898	male
L.27	FrontRoof	560605	female	L50	Parcel_Rack	560898	male
L.84	FrontRoof	560605	female	L51	Parcel_Rack	560898	male
L.85	FrontRoof	560605	female	L52	Passenger_Area	560898	male
L.86	FrontRoof	560605	female	L52	Passenger_Area	560900	female
L.87	FrontRoof	560605	female	L53	Passenger_Area	560898	male
L.88	FrontRoof	560605	female	L53	Passenger_Area	560900	female
L.89	FrontRoof	560605	female	L54	Passenger_Area	560898	male
L.90	FrontRoof	560605	female	L54	Passenger_Area	560900	female
L15	Front_Roof	561247	male	L55	Passenger_Area	560898	male
L16.A	FrontRoof	562615	female	L55	Passenger_Area	560900	female
L16.B	FrontRoof	562615	female	L56	Passenger_Area	560898	male
L17.A	Frontroof	562615	female	L56	Passenger_Area	560900	female
L17.B	FrontRoof	562615	female	L57	Passenger_Area	560898	male
L18.A	FrontRoof	562615	female	L57	Passenger_Area	560900	female
L18.B	FrontRoof	562615	female	L58	Passenger_Area	560898	male
L19	StepCmpt	562549	male	L58	Passenger_Area	560900	female
L20	StepCmpt	562549	male	L59A	OutsideFrontRH	563866	male
L20A	StepCmpt	562486	female	L59B	OutsideFrontRH	563865	female
L28	Parcel_Rack	560898	male	L60A	OutsideFrontLH	563866	male
L29	Parcel_Rack	560898	male	L60B	OutsideFrontLH	563865	female
L30	Parcel_Rack	560898	male	L61	OutsideFrontRH	562601	male
L30A.A	ParcelRack	560898	male	L62	OutsideFrontLH	562601	male
L30AA.A	ParcelRack	560898	male	L63	OutsideFrontRH	562155	male
L30BB.A	ParcelRack	560898	male	L64	OutsideFrontRH	562155	male
L31	Parcel_Rack	560898	male	L65	OutsideFrontLH	562155	male
L32	Parcel_Rack	560898	male	L66	OutsideFrontLH	562155	male
L33	Parcel_Rack	560898	male	L67	OutsideCenterRH	562155	male
L34	Parcel_Rack	560898	male	L68	OutsideCenterRH	562155	male
L35	Parcel_Rack	560898	male	L69	OutsideCenterLH	562155	male
L36	Parcel_Rack	560898	male	L70	OutsideCenterLH	562155	male
L37	Parcel_Rack	560898	male	L71A	RearVehicle	562601	male

# CONNECTORS LIST

No	Location	Part #	Gender	No	Location	Part #	Gender
L72	RrSideLH	562155	male	L184	ServiceCmpt	561247	male
L73A	RearVehicle	562601	male	L185.A	Service_Cmpt	562651	female
L74	RrSideRH	562155	male	L185.B	Service_Cmpt	562290	female
L75	RrSideLH	562155	male	L186.A	Dash	562651	female
L76	RrSideRH	562155	male	L186.B	Dash	562290	female
L77A	RearVehicle	562601	male	L187	Engine_Cmpt	561690	male
L78A	RearVehicle	562601	male	L188	Service_Cmpt	562486	female
L79A	RearVehicle	562601	male	L189	UpperFront	564513	female
L80A	RearVehicle	562601	male	L190	Dash	564513	female
L81.A	RearVehicle	562835	female	L199	EngineCmpt	562848	male
L81.B	RearVehicle	562834	male	L203	RH_Console	561690	male
L82A	RearVehicle	562348	female	L204	Parcel_Rack_RH	562803	male
L83A	RearVehicle	562348	female	L205	EngineCmpt	562485	male
L91A	RearVehicle	562601	male	L206	Parcel_Rack_RH	562803	male
L92A	RearVehicle	562601	male	L207.A	3rdLuggCmpt	561699	female
L130.A	RrAxleCmpt	561690	male	L207.B	3rdLuggCmpt	561701	female
L130.B	RrAxleCmpt	561690	male	L207.C	3rdLuggCmpt	561701	female
L131	RrAxleCmpt	561690	male	L207.D	3rdLuggCmpt	561699	female
L145	Parcelrack	562756	male	L207.E	3rdLuggCmpt	561701	female
L146	ParcelRackLH	562756	male	L207.F	3rdLuggCmpt	561699	female
L147	ParcelRackLH	562756	male	L207.G	3rdLuggCmpt	561699	female
L148	ParcelRackLH	562756	male	L207.H	3rdLuggCmpt	560926	female
L149	ParcelRackLH	562756	male	L207.I	3rdLuggCmpt	560926	female
L150	ParcelRackLH	562756	male	L212	ParcelRackLH	563589	male
L151	ParcelRackLH	562756	male	L213	ParcelRackLH	563589	male
L152	ParcelRackLH	562756	male	L214	ParcelRackLH	563589	male
L153	ParcelRackLH	562756	male	L243	ParcelRackRH	562756	male
L154	ParcelRackLH	562756	male	L244	ParcelRackRH	562756	male
L155	ParcelRackLH	562756	male	L245	ParcelRackRH	562756	male
L156	ParcelRackLH	562756	male	L246	ParcelRackRH	562756	male
L157	ParcelRackLH	562756	male	L247	ParcelRackRH	562756	male
L158	ParcelRackLH	562756	male	L248	ParcelRackRH	562756	male
L173	EngineCmpt	563590	female	L249	ParcelRackRH	562756	male
L174A	EngineCmpt	563590	female	L250	ParcelRackRH	562756	male
L175	CondCmpt	563590	female	L251	ParcelRackRH	562756	male
L176	3rd_Lugg_Cmpt	561247	male	L252	ParcelRackRh	562756	male
L177	3rd_Lugg_Cmpt	561247	male	L253	ParcelRackRH	562756	male
L177A	WCL_Lugg_Door	561690	male	L254	ParcelRackRH	562756	male
L177B	WCL_Lugg_Door	561690	male	L255	ParcelRackRH	562756	male
L180	2nd_Lugg_Cmpt	561247	male	L256	ParcelRackRH	562756	male
L181	2nd_Lugg_Cmpt	561247	male	L280	Driver_Area	561690	male
L182	1st_Lugg_Cmpt	561247	male	L282	3rd_LH_Lugg_Cmpt	561690	male
L183	1st_Lugg_Cmpt	561247	male	L283	Service_Cmpt	562485	male

# CONNECTORS LIST

No	Location	Part #	Gender	No	Location	Part #	Gender
L285.A	Rear_Vehicle	562835	female	R12	Evap_Cmpt	563409	male
L285.B	Rear_Vehicle	562834	male	R13	WCLCmpt	564496	male
L286.A	Rear_Vehicle	562835	female	R14	WCLCmpt	564496	male
L286.B	Rear_Vehicle	562834	male	R21	FJB	560525	male
L298A	EngineCmpt	563590	female	R26	Evap_Cmpt	564496	male
L301	Dash	560898	male	R27	RHConsole	564496	male
L303	EngineCmpt	563590	female	R28	RrSeat	563409	male
L304	EngineCmpt	563590	female	R29	RJB	563409	male
L305.H	Enginecmt	563764	female	R30	FJB	564496	male
L305.P1	Enginecmt	562477	male	R31	FJB	564496	male
L306	RJBCmpt	561247	male	R34	RJB	564210	male
L310	FrInterRoof	560898	male	R36	FJB	564496	male
L310A	FrInterRoof	561552	female	R37	FJB	564496	male
L350.A	RrAxleCmpt	564552	male	R44	P.RackFrLH	564496	male
L350.B	RrAxleCmpt	563340	male	R45	P.RackFrLH	564496	male
L350.C	RrAxleCmpt	562251	male	R47	WCLCmpt	564496	male
L391	Parcel_Rack	560898	male	R50	FJB	564496	male
Mo3	Dash	561667	female	R51	P.RackFrLH	564496	male
Mo4	Dash	564161	male	R52	P.RackFrLH	564496	male
Mo7	CondCmpt	561890	male	R55	FJB	564496	male
Mo8	CondCmpt	561890	male	R57	RJB	564496	male
Mo10	P.RackLH	561515	male	R65	P.RackFrLH	564496	male
Mo11	P.RackRH	561515	male	R66	P.RackFrLH	564496	male
Mo12	EvapCmpt	561690	male	R210	Parcel_Rack_LH	560525	male
Mo17	Service_Cmpt	563626	male	Res3.A	ParcelRack	563590	female
Mo19	Service_Cmp	562474	male	Res4	RH_Console	563590	female
Mo20	Service_Cmpt	562474	male	Res6	RJB	563590	female
Mo22	RH_Console	561186	male	Res7	Dash	563590	female
Mo27	CondCmpt	561890	male	Res15	EngineCmpt	561782	male
Mo28	CondCmpt	561890	male	Res20	Parcel_Rack	563590	female
Mo29	RJB	563590	female	Res31	UreaCmpt	562350	male
Mo37	ServiceCmpt	562477	male	Res32	UreaCmpt	563764	female
Mo38	WCLUperDoor	564161	male	Res37.A	Front_Clearance	561690	male
Mo65	EngineCmpt	568089	male	Res37.B	Front_Clearance	561690	male
Mo67	EngineCmpt	568089	male	Res46	RrAxleCmpt	563590	female
Mo68	EngineCmpt	568089	male	Res53	Dash	563590	female
Mo69	EngineCmpt	568089	male	RT34.1	FJB	561904	female
Mo70	EngineCmpt	568089	male	RT34.2	FJB	561904	female
Mo71	EngineCmpt	568089	male	RT34.3	FJB	561904	female
Mo72	EngineCmpt	568089	male	Se2	LH_Console	561566	female
Mo73	EngineCmpt	568089	male	Se11.A	Cond_Cmpt	564460	female
R1	R1	562486	female	Se11.B	Cond_Cmpt	564460	female
R3	RJB	563409	male	Se11.C	Cond_Cmpt	564460	female

# CONNECTORS LIST

No	Location	Part #	Gender	No	Location	Part #	Gender
Se13	Engine_Cmpt	562350	male	Se79	Front_Axle	563340	male
Se14.A	Driver_Area	561782	male	Se83	FrontAxle	642190	female
Se14.B	Driver_Area	561781	female	Se84	FrontAxle	642190	female
Se18	PneuPlate	561566	female	Se85	RearAxle	642190	female
Se19_P	Service_Cmpt	563677	male	Se86	RearAxle	642190	female
Se19_S	ServiceCmpt	563677	male	Se87	RearAxle	642190	female
Se20	Head_Lamp_RH	562426	male	Se88	RearAxle	642190	female
Se21	Dash	561248	female	Se89	EngineCmpt	562350	male
Se22	CondCmpt	562877	female	Se94	WCLUpperdoor	562877	female
Se23	Engine_Cmpt	563159	male	Se100	WCLUpperdoor	562479	female
Se24	EvapCmpt	563758	female	shell1	RJB	561932	male
Se25	Passenger_Area	561248	female	shell1_1	Luggage_Cmpt	561690	male
Se29	Engine_Cmpt	561566	female	So4	RH_Console	641385	male
Se30	EngineCmpt	562877	female	So5	RH_Console	641385	male
Se31	EngineCmpt	562877	female	So6	RH_Console	641385	male
Se32	Rear_Axle_Cmpt	562426	male	So7	Service_Cmpt	561566	female
Se33	Rear_Axle_Cmpt	562856	male	So8	ServiceCmpt	641385	male
Se34	Rear_Axle_Cmpt	562426	male	So9	EngineCmpt	560016	female
Se35	Rear_Axle_Cmpt	562426	male	So10	CondCmpt	562485	male
Se36	Rear_Axle_Cmpt	562427	male	So11	Cond_Cmpt	561566	female
Se37	Front_Axle_LH	641132	female	So13	Evap_Cmpt	563204	female
Se38	Front_Axle_RH	641132	female	So15	PneuPlate	641385	male
Se39	Rear_Axle_LH	641132	female	So16	PneuPlate	641385	male
Se40	Rear_Axle_LH	641132	female	So17	PneuPlate	562848	male
Se45.A	ServiceCmpt	563409	male	So20	PneuPlate	641385	male
Se49	Engine_Cmpt	561690	male	So21	Front_Axle_Cmpt	564046	female
Se50.A	FJB	561904	female	So22	Front_Axle_Cmpt	564046	female
Se50.B	FJB	561904	female	So23	Rear_Axle_Cmpt	564046	female
Se51	FJB	563589	male	So24	Rear_Axle_Cmpt	564046	female
Se53	Service_Cmpt	563159	female	So27	RearAxleCmpt	564045	female
Se54	Service_Cmpt	563159	female	So29	WCLCmpt	641385	male
Se55	Service_Cmpt	563159	female	So50	RearAxleCmpt	564046	female
Se56	WCLCmpt.	562479	female	So52	FrontAxleCmpt	564045	female
Se62	WCLLuggDoor	561690	male	So53	Rear_Axle_Cmpt	641385	male
Se63	EngineCmpt	641132	female	So55	PneuPlate	562848	male
Se64	EngineCmpt	641132	female	So70	PneumaticPanel	641385	male
Se65	Dash	564042	female	spBar2	Engine_Cmpt	564135	male
Se66	FrontAxle	564039	female	spBar3	Parcel_Rack_LH	564135	male
Se67	FJB	563159	female	spBar4	EngineCmpt	564135	male
Se69	FJB	563159	female	spBar5	EngineCmpt	564135	male
Se76	EntranceDoor	562479	female	spBar6	EngineCmpt	564135	male
Se77	FrontVehicle	563159	female	spBar7	UreaCmpt	564135	male
Se78	PneuPlate	563159	female	spBar11	RearVehicle	564135	male



# CONNECTORS LIST

No	Location	Part #	Gender	No	Location	Part #	Gender
spBar12	RearVehicle	564135	male	Spk23.A	FroutsidelH	563994	male
spBar13	EngineCmpt	564135	male	Spk23.B	FroutsiderH	563996	female
spBar14	EngineCmpt	564135	male	Spk24	Froutsidecenter	563994	male
spBar15	EngineCmpt	564135	male	Spk25	Froutsidecenter	563994	male
spBar16	EngineCmpt	564135	male	Sw2	Dash	562763	male
spBar19	CondensorCmpt	564135	male	Sw4	Dash	562763	male
spBar20	CondensorCmpt	564135	male	Sw10A	LH_Console	562763	male
spBar21	CondensorCmpt	564135	male	Sw12	Dash	562763	male
spBar22	EngineCmpt	564135	male	Sw13	Dash	562763	male
spBar23	EngineCmpt	564135	male	Sw14	Dash	562763	male
spBar24	FJB	564135	male	Sw16	Dash	562763	male
spBar25	EngineCmpt	564135	male	Sw17	Dash	562763	male
spBar26	FrAxleCmpt	564135	male	Sw20	Dash	562763	male
spBar27	FrAxleCmpt	564135	male	Sw24	Dash	562763	male
Spk1_L	Parcel_Rack_LH	563994	male	Sw25	Dash	562763	male
Spk1_R	Parcel_Rack_RH	563994	male	Sw29	Dash	562763	male
Spk2_L	Parcel_Rack_LH	563994	male	Sw30	LHConsol	562763	male
Spk2_R	Parcel_Rack_RH	563994	male	Sw34	FrEntranceDoor	563832	female
Spk3_L	Parcel_Rack_LH	563994	male	Sw38	LH_Console	562763	male
Spk3_R	Parcel_Rack_RH	563994	male	Sw41	LH_Console	562749	male
Spk4_L	Parcel_Rack_LH	563994	male	Sw42	WCL_Cmpt	561635	female
Spk4_R	Parcel_Rack_RH	563994	male	Sw44.A	FJB	562403	female
Spk5_L	Parcel_Rack_LH	563994	male	Sw45.A	3rd_Lugg_Cmpt	562403	female
Spk5_R	Parcel_Rack_RH	563994	male	Sw46.A	3rd_Lugg_Cmpt	562403	female
Spk6_L	Parcel_Rack_LH	563994	male	Sw46B.A	3rdLuggCmpt.	562403	female
Spk6_R	Parcel_Rack_RH	563994	male	Sw46B.B	3rdLugg.Cmpt.	562403	female
Spk7_L	Parcel_Rack_LH	563994	male	Sw49.A	2nd_Lugg_Cmpt	562403	female
Spk7_R	Parcel_Rack_RH	563994	male	Sw50.A	2nd_Lugg_Cmpt	562403	female
Spk8_L	Parcel_Rack_LH	563994	male	Sw51.A	1st_Lugg_Cmpt	562403	female
Spk8_R	Parcel_Rack_RH	563994	male	Sw52.A	1st_Lugg_Cmpt	562403	female
Spk9_L	Parcel_Rack_LH	563994	male	Sw58	EngineCmpt.	563135	male
Spk9_R	Parcel_Rack_RH	563994	male	Sw59	EngineCmpt.	563135	male
Spk10_L	Parcel_Rack_LH	563994	male	Sw64.A	Service_Cmpt	560815	female
Spk10_R	Parcel_Rack_RH	563994	male	Sw64.B	Service_Cmpt	560815	female
Spk11_L	Parcel_Rack_LH	563994	male	Sw70	Dash	562763	male
Spk11_R	Parcel_Rack_RH	563994	male	Sw71	EngineCmpt	562348	female
Spk12_L	Parcel_Rack_LH	563994	male	Sw80A	EngineCmpt	562763	male
Spk12_R	Parcel_Rack_RH	563994	male	Sw81.A	Dash	562905	male
Spk13_L	Parcel_Rack_LH	563994	male	Sw81.B	Dash	562905	male
Spk13_R	Parcel_Rack_RH	563994	male	Sw82A	RJB	563618	male
Spk14_L	Parcel_Rack_LH	563994	male	Sw83A	Dash	562581	male
Spk14_R	Parcel_Rack_RH	563994	male	Sw84	EngineCmpt.	563135	male
Spk22	Dash	563994	male	Sw85	LH_Console	562749	male

# CONNECTORS LIST

No	Location	Part #	Gender	No	Location	Part #	Gender
Sw95.A	WCLDoor	561626	female	Tab70b.A	ParcelRack	561626	N/A
Sw95.B	WCLDoor	561626	female	TermL152B	ParcelRackLH	562505	N/A
Sw96.A	WCL_Door	562615	female	TermL249B	ParcelRackRH	562505	N/A
Sw96.B	WCL_Door	562615	female	USB.MOD	1stseat	561690	male
Sw96.C	WCLDoor	562615	female	USB.MOD	1stseat	561566	female
Sw97.A	WCLSystem	562615	female	USB.WCL.F	PassengerArea	561690	male
Sw97.B	WCLSystem	562615	female	USB.WCL.F	PassengerArea	561566	female
Sw97.C	WCLSystem	562615	female	USB.WCL.F	PassengerArea	561690	male
Sw98.A	WCLSystem	561626	female	USB.WCL.F	PassengerArea	561566	female
Sw98.B	WCLSystem	561626	female	USB1L	PassengerArea	563025	male
Sw103	LH_Console	562763	male	USB1R	PassengerArea	563025	male
Sw105	Dash	563590	female	USB2	Passenger_Area	563025	male
Sw116.A	Luggages	560079	female	USB2L	Passenger_Area	561690	male
Sw116.B	Luggages	560079	female	USB2R	Passenger_Area	561690	male
Sw122	Dash	562763	male	USB3L	Passenger_Area	561690	male
Sw123	Dash	562763	male	USB3R	Passenger_Area	561690	male
Sw137	Dash	562763	male	USB4L	Passenger_Area	561690	male
Sw138	FJB	561690	male	USB4R	Passenger_Area	561690	male
Sw139	FJB	561690	male	USB5L	Passenger_Area	561690	male
Sw140	FJB	561566	female	USB5R	Passenger_Area	561690	male
Sw141	FJB	561690	male	USB6L	Passenger_Area	561690	male
Sw142	LHConsole	562763	male	USB6R	Passenger_Area	561690	male
Sw143	Driver_Area	562485	male	USB7L	Passenger_Area	561690	male
Sw144	FJB	561690	male	USB7R	Passenger_Area	561690	male
Sw152	Driver_Area	562471	male	USB8L	Passenger_Area	563025	male
Sw152.	Driver_Area	562471	male	USB9L	Passenger_Area	563025	male
Sw161	Dash	562763	male	USB9R	Passenger_Area	563025	male
sym691_1	Parcel_Rack_LH	562464	male	USB10L	Passenger_Area	561690	male
sym762_1	FrInterRoof	561611	male	USB10R	Passenger_Area	561690	male
sym762_1	FrInterRoof	561610	female	USB11L	Passenger_Area	561690	male
sym780_1	FrInterRoof	563040	female	USB11R	Passenger_Area	561690	male
sym781_1	FrInterRoof	563071	male	USB12L	Passenger_Area	561690	male
sym797_2	ParcelRack	565180	female	USB12R	Passenger_Area	561690	male
sym803_2	ParcelRack	565180	female	USB13L	Passenger_Area	561690	male
sym814_2	ParcelRack	565180	female	USB13R	Passenger_Area	561690	male
sym815_2	ParcelRack	565180	female	USB14L	Passenger_Area	561690	male
sym816_2	ParcelRack	565180	female	USB14R	Passenger_Area	561690	male
sym824_2	ParcelRack	565180	female	USB_Mod	Passenger_Area	561690	male
sym826_2	ParcelRack	565180	female	USB_Mod	Passenger_Area	561566	female
Tab1.A	ParcelRack	561626	N/A	USB_WCL	Passenger_Area	563025	male
tab69.A	ParcelRack	565180	N/A	VECF1	FJB	563186	male
tab70.A	ParcelRack	565180	N/A	VECF2	FJB	563183	male
Tab70a.A	ParcelRack	561626	N/A	VECF3	FJB	563185	male

# CONNECTORS LIST

No	Location	Part #	Gender	No	Location	Part #	Gender
VECF4	FJB	563182	male				
VECF9	FJB	563448	male				
VECF10	FJB	563181	male				
VECF11	FJB	563184	male				
VECF12	FJB	563187	male				
VECPR1	Parcelrack_LH	563715	male				
VECPR2	Parcelrack_LH	563716	male				
VECPR3	Parcelrack_LH	563718	male				
VECPR4	Parcelrack_LH	563714	male				
VECR1	RJB	563186	male				
VECR2	RJB	563183	male				
VECR3	RJB	563185	male				
VECR4	RJB	563182	male				
VECR9	RJB	563448	male				
VECR10	RJB	563181	male				
VECR11	RJB	563184	male				
VECR12	RJB	563187	male				
Y80	Engine_Cmpt	563789	male				
Y81	Cond_Cmpt	563793	male				

# CONNECTORS LIST

No	Location	Part #	Gender	No	Location	Part #	Gender
A1	RJB	563975	male	A78	RJB	6E+05	female
A2	FJB	563984	male	A79	RJB	6E+05	female
A3.A	dash	565910	male	A80	EngineCmpt.	6E+05	female
A3.B	Dash	565908	male	A81.JA	FJB	6E+05	male
A3.C	Dash	565909	male	A81.JB	FJB	6E+05	male
A5	Service_Cmpt	562428	female	A81.JC	FJB	6E+05	male
A6	Engine_Cmpt	562427	male	A83	FJB	6E+05	female
A7	Rear_Axle_Cmpt	563979	male	A96	FJB	6E+05	male
A9.Cx1	FJB	564041	female	A97.A1	Dash	6E+05	male
A9.Cx2	FJB	563678	male	A97.A2	Dash	6E+05	male
A9.Cx3	FJB	564037	male	A97.A3	Dash	6E+05	male
A9.Cx4	FJB	564038	female	A98	Upperfront	6E+05	male
A14A.A	Dash	562766	male	A99	FJB	6E+05	male
A14A.B	Dash	562767	male	A100	FrontAxle	6E+05	male
A14A.C	Dash	562765	male	A101	RearRH Axel	6E+05	male
A15	Dash	562464	male	A102	RearLH Axel	6E+05	male
A18.J1	FJB	562794	male	A103	Dash	6E+05	female
A18.J2	FJB	562650	male	A104	Dash	6E+05	female
A24.A	RH_Console	561890	male	A107	Parcel_rack_LH	6E+05	male
A24.B	RH_Console	561566	female	A108.P1	Parcel_Rack_LH	6E+05	male
A27	Service_Cmpt	562929	male	A108.P2	Parcel_Rack_LH	6E+05	male
A28	Service_Cmpt	562928	male	A110.A	InterFrRoof	6E+05	female
A34.7	Rad_Cmpt	564258	male	A111	Entrancedoor	6E+05	male
A34.J	Rad_Cmpt	568118	male	A112.X1	Parcel_Rack	bidon	male
A34.K	Rad_Cmpt	564270	male	A112.X2	Parcel_Rack	bidon	male
A34.L	Rad_Cmpt	564269	male	A112.X3	Parcel_Rack	bidon	male
A36.JA	FJB	562767	male	A112.X4	Parcel_Rack	6E+05	male
A36.JB	FJB	562765	male	A112.X5	Parcel_Rack	bidon	male
A36.JC	FJB	562957	male	A112.X6	Parcel_Rack	bidon	male
A37.JA	FJB	562767	male	A112.X7	Parcel_Rack	bidon	male
A37.JB	FJB	562765	male	A113.X1	Parcel_Rack	6E+05	male
A37.JC	FJB	562957	male	A113.X2	Parcel_Rack	bidon	male
A69L.A	P.RackLH	563025	male	A113.X3	P.RackLH	6E+05	male
A69L.B2	P.RackLH	bidon	male	A113.X4	P.RackLH	bidon	male
A69L.B4	P.RackLH	bidon	male	A130.	Driver_Area	6E+05	male
A69L.C	P.RackLH	bidon	male	A130.J1	3rd_LH_Lugg_Cmpt	6E+05	male
A69R.A	P.RackLH	563025	male	A130.J2	3rd_LH_Lugg_Cmpt	6E+05	male
A69R.B1	P.RackLH	bidon	male	A130.J4	3rd_LH_Lugg_Cmpt	6E+05	male
A69R.B2	P.RackLH	bidon	male	A131.A	Engine_Cmpt	6E+05	male
A69R.B3	P.RackLH	bidon	male	A131.B	Engine_Cmpt	6E+05	female
A69R.B4	P.RackLH	bidon	male	A132.A	Driver_Area	6E+05	male
A69R.C	P.RackLH	bidon	male	A132.B	Driver_Area	6E+05	female
A77	RJB	564547	male	A134.A	Engine_Cmpt	6E+05	male

# CONNECTORS LIST

No	Location	Part #	Gender	No	Location	Part #	Gender
A134.B	Engine_Cmpt	561781	female	AE51.J2	RJB	564037	female
A135.A	Engine_Cmpt	561782	male	AE51.J3	RJB	565957	male
A135.B	Engine_Cmpt	561781	female	AE52.J1	RJB	563679	male
A136.A	Engine_Cmpt	561782	male	AE52.J2	RJB	564037	female
A136.B	Engine_Cmpt	561781	female	AE52.J3	RJB	565957	male
A138	CondensorCmpt.	563787	male	AE53.J1	RJB	563679	male
A139.A	3rd_LH_Lugg_Cmpt	561782	male	AE53.J2	RJB	564037	female
A139.B	3rd_LH_Lugg_Cmpt	561781	female	AE53.J3	RJB	565957	male
A139.C	3rd_LH_Lugg_Cmpt	565158	female	AE54.J1	EvaporatorCmpt.	563679	male
A140	Driver_Area	563226	male	AE54.J2	EvaporatorCmpt.	564037	female
A160.A	LuggCmpt	562477	male	AE54.J3	CondensorCmpt.	565957	male
A160.B	LuggCmpt	562884	female	AE55.J1	Dash	563679	male
AE41.J1	FJB	563679	male	AE55.J2	Dash	564037	female
AE41.J2	FJB	564037	female	AE55.J3	Dash	564004	male
AE41.J3	FJB	564004	male	AE56.J1	Dash	563679	male
AE42.J1	FJB	563679	male	AE56.J2	Dash	564037	male
AE42.J2	FJB	564037	female	AE56.J3	Dash	564004	male
AE42.J3	FJB	564004	male	AE57.J1	WCLCmpt.	563679	male
AE43.J1	FJB	563679	male	AE57.J2	WCLCmpt.	564037	male
AE43.J2	FJB	564037	male	AE57.J3	WCLCmpt.	564004	male
AE43.J3	FJB	565957	male	Alt_LR.A	EngineCmpt.	563746	female
AE44.J1	FJB	563679	male	Alt_LR.B	EngineCmpt.	560815	female
AE44.J2	FJB	564037	female	Alt_LR.C	EngineCmpt.	564469	female
AE44.J3	FJB	565957	male	Alt_UR.A	EngineCmpt.	563746	female
AE45.J1	FJB	563679	male	Alt_UR.B	EngineCmpt.	560815	female
AE45.J2	FJB	564037	female	Alt_UR.C	EngineCmpt.	564469	female
AE45.J3	FJB	565957	male	AltLL.A	EngineCmpt.	563746	female
AE46.J1	FJB	563679	male	AltLL.B	EngineCmpt.	560815	female
AE46.J2	FJB	564037	female	AltLL.C	EngineCmpt.	564469	female
AE46.J3	FJB	565957	male	B85	EngineCmpt	563815	male
AE47.J1	RHConsole	563679	male	B96	EngineCmpt	563821	male
AE47.J2	RHConsole	564037	female	B96B	EngineCmpt	563823	male
AE47.J3	RHConsole	565957	male	B97	EngineCmpt	563816	male
AE48.J1	RHConsole	563679	male	B98	EngineCmpt	563817	male
AE48.J2	RHConsole	564037	female	B99	EngineCmpt	563815	male
AE48.J3	RHConsole	565957	male	B115A	EngineCmpt.	564226	male
AE49.J1	RJB	563679	male	B142C	EngineCmpt.	563793	male
AE49.J2	RJB	564037	male	B310	EngineCmpt.	565967	male
AE49.J3	RJB	565957	male	C.243	ServiceCmpt.	562789	male
AE50.J1	RJB	563679	male	C.243	ServiceCmpt.	565131	female
AE50.J2	RJB	564037	male	C1	FJB	563589	male
AE50.J3	RJB	565957	male	C1	FJB	563590	female
AE51.J1	RJB	563679	male	C1A	FJB	561611	male

# CONNECTORS LIST

No	Location	Part #	Gender	No	Location	Part #	Gender
C1A	FJB	561610	female	C18	FJB	561986	male
C1B	Parcel_Rack_LH	561611	male	C18	FJB	561987	female
C1B	Parcel_Rack_LH	561610	female	C19	RJB	561986	male
C1S	FJB	563589	male	C19	RJB	561987	female
C1S	FJB	563590	female	C20A	AFSS	562485	male
C2	Service_Cmpt	563580	male	C20A	AFSS	562486	female
C2	Service_Cmpt	563581	female	C20B	Evap_Cmpt	562485	male
C2A	FJB	563580	male	C20B	Evap_Cmpt	562486	female
C2A	FJB	563581	female	C23	Evap.Cmpt.	564034	male
C2bb	FJB	564034	male	C23	Evap.Cmpt.	564035	female
C2bb	FJB	564035	female	C24_plug	Evap_Cmpt	561690	male
C3_plug	RJB	563589	male	C24_sock	Evap_Cmpt	561566	female
C3_socket	RJB	563590	female	C25	Parcel_Rack_LH	561550	male
C3S	RJB	563593	male	C25	Parcel_Rack_LH	561667	female
C3S	RJB	563590	female	C25.	Parcel_Rack_LH	561669	male
C4	FJB	563580	male	C25.	Parcel_Rack_LH	561670	female
C4	FJB	563581	female	C25A	ParcalrackLH	561515	male
C5	FJB	563589	male	C25A	ParcelRackLH	561552	female
C5	FJB	563590	female	C25A.	ParcalrackLH	561669	male
C5S	FJB	563589	male	C25A.	ParcalrackLH	561670	female
C5S	FJB	563590	female	C26	UreaCmpt.	563226	male
C6	FJB	563582	male	C26	UreaCmpt.	563613	female
C6	FJB	563583	female	C26A	UreaCmpt.	568110	male
C9	RJB	561986	male	C26A	UreaCmpt.	568109	female
C9	RJB	561987	female	C26B	UreaCmpt.	563227	male
C10	Engine_Cmpt	562477	male	C26B	UreaCmpt.	563614	female
C10	Engine_Cmpt	562479	female	C29	3rd_Lugg_Cmpt	563651	male
C11	Service_Cmpt	563580	male	C29	3rd_Lugg_Cmpt	563652	female
C11	Service_Cmpt	563581	female	C30	3rd_Lugg_Cmpt	561710	male
C12	Engine_Cmpt	562581	male	C30	3rd_Lugg_Cmpt	561709	female
C12	Engine_Cmpt	562583	female	C31W	3rdLuggCmpt.	563227	male
C13_plug	RH_Console	563589	male	C31W	3rdLuggCmpt.	563614	female
C13_socket	RH_Console	563590	female	C32W	WCLCmpt.	561640	male
C13S	RH_Console	563589	male	C32W	WCLCmpt.	561639	female
C13S	RH_Console	563590	female	C33	WCLCmpt.	564034	male
C14	RJB	561986	male	C33	WCLCmpt.	564035	female
C14	RJB	561987	female	C33W	WCLCmpt.	562477	male
C15A	EvapCmpt	568110	male	C33W	WCLCmpt.	562479	female
C15A	EvapCmpt	568109	female	C34	RH_Console	561986	male
C16	RJB	561577	male	C34	RH_Console	561987	female
C16	RJB	561605	female	C35	WCLdoor	562485	male
C17	RJB	560195	male	C35	WCLdoor	562486	female
C17	RJB	560169	female	C36	FJB	561986	male

# CONNECTORS LIST

No	Location	Part #	Gender	No	Location	Part #	Gender
C36	FJB	561987	female	C62	Fr_Service_Door	562566	male
C37	Parcel_Rack_LH	562557	male	C62	Fr_Service_Door	562565	female
C37	Parcel_Rack_LH	562558	female	C64	EngineCmpt.	568110	male
C37.	Parcel_Rack_LH	561734	male	C64	EngineCmpt.	568109	female
C37.	Parcel_Rack_LH	561735	female	C68	P.RackLH	561646	male
C38	ParcelRackLH	562555	male	C68	P.RackLH	561644	female
C38	ParcelRackLH	562556	female	C70	FJB	561646	male
C38.	ParcelRackLH	561734	male	C70	FJB	561645	female
C38.	ParcelRackLH	561735	female	C70B	FJB	561710	male
C39A	Engine_Cmpt	561782	male	C70B	FJB	561989	female
C39A	Engine_Cmpt	561781	female	C71	FJB	561646	male
C40	Dash	562485	male	C71	FJB	561645	female
C40	Dash	562486	female	C72	FJB	561646	male
C44_plug	FJB	561577	male	C72	FJB	561645	female
C44_socket	FJB	561605	female	C74	FJB	561710	male
C45	FJB	561643	male	C74	FJB	561989	female
C45	FJB	561642	female	C77	FJB	562350	male
C46	WCLCmpt.	564228	male	C77	FJB	563764	female
C46	WCLCmpt.	564229	female	C79	RJB	561986	male
C50	RJB	563931	male	C79	RJB	561987	female
C50	RJB	563930	female	C81_plug	1stLuggCmpt.	562477	male
C51	Engine_Cmpt	561932	male	C81_socket	1stLuggCmpt.	562479	female
C51	Engine_Cmpt	560933	female	C82	1stLuggCmpt.	562581	male
C52	Evap.Cmpt.	563618	male	C82	2ndLuggCmpt.	562583	female
C52	Evap.Cmpt.	563616	female	C83_plug	2ndLuggCmpt.	562477	male
C54	EngineCmpt.	563226	male	C83_socket	2ndLuggCmpt.	562479	female
C54	EngineCmpt.	563613	female	C84_plug	2ndLuggCmpt.	562477	male
C54A	EngineCmpt.	568110	male	C84_socket	2ndLuggCmpt	562479	female
C54A	EngineCmpt.	568109	female	C85_plug	3rdLuggCmpt.	562477	male
C54B	EngineCmpt.	563589	male	C85_socket	3rdLuggCmpt.	562479	female
C54B	EngineCmpt.	563590	female	C86	3rdLuggCmpt.	563618	male
C56	3rd_LH_Lugg_Cmpt	561643	male	C86	3rdLuggCmpt.	563616	female
C56	3rd_LH_Lugg_Cmpt	561642	female	C87	Engine_Cmpt	562485	male
C57	3rd_LH_Lugg_Cmpt	561782	male	C87	Engine_Cmpt	562486	female
C57	3rd_LH_Lugg_Cmpt	561781	female	C88	WCLCmpt.	563227	male
C57A	Engine_Cmpt	561690	male	C88	WCLCmpt.	563614	female
C57A	Engine_Cmpt	561566	female	C91	RJB	564619	male
C58	CondensorCmpt.	564567	male	C91	RJB	562282	female
C58	CondensorCmpt.	564568	female	C92A	EngineCmpt.	563226	male
C59	LuggCmpt.	561646	male	C92A	EngineCmpt.	563613	female
C59	LuggCmpt.	561645	female	C92B	EngineCmpt.	562581	male
C61	Fr_Service_Door	561669	male	C92B	EngineCmpt.	562583	female
C61	Fr_Service_Door	561670	female	C92C	EngineCmpt.	562581	male

# CONNECTORS LIST

No	Location	Part #	Gender	No	Location	Part #	Gender
C92C	EngineCmpt.	562583	female	C171	LH_Console	561646	male
C94_plug	FJB	563589	male	C171	LH_Console	561645	female
C94_socket	FJB	563590	female	C175	RJB	563226	male
C95	FJB	561646	male	C175	RJB	563613	female
C95	FJB	561645	female	C193_r	RJB	563589	male
C96	FJB	561643	male	C193_s	RJB	563590	female
C96	FJB	561642	female	C194	FJB	563589	male
C97	FJB	561643	male	C194	FJB	563590	female
C97	FJB	561642	female	C206	Parcel_Rack_RH	562503	male
C98	2nd_LH_Lugg_Cmpt	562581	male	C206	Parcel_Rack_RH	562507	female
C98	2nd_LH_Lugg_Cmpt	562583	female	C207	Parcel_Rack_LH	562503	male
C99	2nd_RH_Lugg_Cmpt	562581	male	C207	Parcel_Rack_LH	562507	female
C99	2nd_RH_Lugg_Cmpt	562583	female	C213	Parcel_Rack_LH	561515	male
C100	EvapCmpt.	562477	male	C213	Parcel_Rack_LH	561552	female
C100	EvapCmpt.	562479	female	C223	FJB	563227	male
C100S	EvapCmpt.	562477	male	C223	FJB	563614	female
C100S	EvapCmpt.	562479	female	C226	FJB	562650	male
C101	Service_Cmpt	561690	male	C226	FJB	562649	female
C101	Service_Cmpt	561566	female	C227	FJB	562650	male
C102A	CondensorCmpt.	563226	male	C227	FJB	562649	female
C102A	CondensorCmpt.	563613	female	C229	Dash	561782	male
C104S_plug	LuggCmpt.	563589	male	C229	Dash	561781	female
C104S_socket	LuggCmpt.	563590	female	C230	FrontInterRoof	562477	male
C110	PneumaticPanel	568110	male	C230	FrontInterRoof	562479	female
C110	PneumaticPanel	568109	female	C231	FJB	563409	male
C115	FrInterRoof	561690	male	C231	FJB	563410	female
C115	FrInterRoof	561566	female	C242	Service_Cmpt	562789	male
C116	FrInterRoof	561611	male	C242	Service_Cmpt	565131	female
C116	FrInterRoof	561610	female	C243	ServiceCmpt.	563347	male
C117	Parcel_Rack_LH	561690	male	C243	ServiceCmpt.	563180	female
C117	Parcel_Rack_LH	561566	female	C259	LuggCmpt	561637	male
C119	EngineDoor	568110	male	C259	LuggCmpt	561636	female
C119	EngineDoor	568109	female	C266	Parcelrack	561782	male
C121	EngineDoor	563347	male	C266	Parcelrack	561781	female
C121	EngineDoor	563180	female	C267	Parcelrack	561782	male
C122	EngineDoor	568118	male	C267	Parcelrack	561781	female
C122	EngineDoor	562531	female	C279	Service_Cmpt	562477	male
C144	ParcelRackJB	560852	male	C279	Service_Cmpt	562479	female
C144	ParcelRackJB	560851	female	C284	Parcel_Rack_LH	561247	male
C152	Cond_Cmpt	561611	male	C284	Parcel_Rack_LH	561248	female
C152	Cond_Cmpt	561610	female	C284_1	Parcel_Rack_LH	561247	male
C158	CondCmpt.	562477	male	C284_1	Parcel_Rack_LH	561248	female
C158	CondCmpt.	562479	female	C284_2	Parcel_Rack_LH	561247	male



# CONNECTORS LIST

No	Location	Part #	Gender	No	Location	Part #	Gender
C284_2	Parcel_Rack_LH	561248	female	C577A	Parcel_Rack	562006	male
C284_3	Parcel_Rack_LH	561247	male	C577A	Parcel_Rack	560908	female
C284_3	Parcel_Rack_LH	561248	female	C577AA	ParcelRack	562006	male
C284_4	Parcel_Rack_LH	561247	male	C577AA	ParcelRack	560908	female
C284_4	Parcel_Rack_LH	561248	female	C578	ParcelRackJB	562503	male
C284_5	Parcel_Rack_LH	561247	male	C578	ParcelRackJB	562507	female
C284_5	Parcel_Rack_LH	561248	female	C579	P.RackLH	562549	male
C349	Engine_Cmpt	565170	male	C579	P.RackLH	562550	female
C350	Engine_Cmpt	565170	male	C_ALT	EngineCmpt.	562581	male
C355	RJB	563582	male	C_ALT	EngineCmpt.	562583	female
C355	RJB	563583	female	C_ALT3	EngineCmpt.	562477	male
C356	ParcelRackJB	561710	male	C_ALT3	EngineCmpt.	562479	female
C356	ParcelRackJB	561709	female	C_BCIS_BHS	P.RackLH	561643	male
C357	P.RackJCB	564294	male	C_BCIS_BHS	P.RackLH	561641	female
C357	P.RackJCB	564295	female	C_BCIS_IFU	P.RackLH	562650	male
C358	P.RackLH	566033	male	C_BCIS_IFU	P.RackLH	562649	female
C358	P.RackLH	566034	female	C_BCIS_ODK	P.RackLH	562650	male
C380A	Dash	564222	male	C_BCIS_ODK	P.RackLH	562649	female
C380A	Dash	564224	female	C_BCIS_PWR	P.RackLH	561550	male
C397	RJB	562285	male	C_BCIS_PWR	P.RackLH	561667	female
C397	RJB	562282	female	C_BCIS_RDR	P.RackLH	565940	male
C463	EngineCmpt	568112	male	C_BCIS_SIG	P.RackLH	561690	male
C463	EngineCmpt	568111	female	C_BCIS_SIG	P.RackLH	561566	female
C464A	RJB	564222	male	C_BCIS_SW	P.RackLH	561637	male
C464A	RJB	564224	female	C_BCIS_SW	P.RackLH	561636	female
C465	Parcelrack	562581	male	C_BCIS_SW1	P.RackLH	561637	male
C465	Parcelrack	562583	female	C_BCIS_SW1	P.RackLH	561636	female
C466	LH_Consol	562503	male	C_Bike_Se	Front_Axle	562901	male
C466	LH_Consol	562507	female	C_Bike_Se	Front_Axle	562902	female
C574	P.RackRH	562549	male	C{EIF	Engine_Cmpt	563135	male
C574	P.RackRH	562550	female	C{EIF	Engine_Cmpt	563134	female
C575	ParcelRackRH	562503	male	C_Foot	FJB	563347	male
C575	ParcelRackRH	562507	female	C_Foot	FJB	563180	female
C576	Parcel_Rack_RH	561515	male	C_INV1	ParcelRack	562337	male
C576	Parcel_Rack_RH	561552	female	C_INV1	ParcelRack	562338	male
C576A	Parcel_Rack_RH	561515	male	C_INV2_1	ParcelRack	562337	male
C576A	Parcel_Rack_RH	561552	female	C_INV2_1	ParcelRack	562338	male
C576B	Parcel_Rack_RH	562006	male	C_INV2_2	ParcelRack	562337	male
C576B	Parcel_Rack_RH	560908	female	C_INV2_2	ParcelRack	562338	female
C576BB	ParcelRack	562006	male	C_INV3	ParcelRack	562337	male
C576BB	ParcelRack	560908	female	C_INV3	ParcelRack	562338	female
C577	Parcel_Rack	561515	male	C_JP_FBOX	Parcel_Rack_LH	561782	male
C577	Parcel_Rack	561552	female	C_JP_FBOX	Parcel_Rack_LH	561781	female

# CONNECTORS LIST

No	Location	Part #	Gender	No	Location	Part #	Gender
C_JP_Rad	Parcel_Rack_LH	561782	male	CIND1.A	ParcelRack	560908	female
C_JP_Rad	Parcel_Rack_LH	561781	female	CIND1.B	ParcelRack	560908	female
C_Mo9_p	Evap_Cmpt	561577	male	CIND_1.A	ParcelRack	560908	female
C_Mo9_s	Evap_Cmpt	561605	female	CIND_1.B	ParcelRack	560908	female
C_MVIEW	ParcelRackLH	563227	male	CINDWC-1.A	ParcelRack	560908	female
C_MVIEW	ParcelRackLH	563614	female	CINDWC-1.B	ParcelRack	560908	female
C_MVIEW	ParcelRackLH	39-01-214	male	CJUP1	Dash	560898	male
C_MVIEW	ParcelRackLH	39-01-214	female	CJUP1	Dash	560900	female
C_MVIEW	ParcelRackLH	562779	male	CJUP4	Dash	560898	male
C_MVIEW	ParcelRackLH	562465	male	CJUP4	Dash	560900	female
C_MVIEW	ParcelRackLH	562842	male	CJUR1	Dash	562485	male
C_USB1_f	Passenger_Area	561566	female	CJUR1	Dash	562486	female
C_USB1_f	Passenger_Area	561690	male	CJUR2	Dash	561577	male
C_USB1_l	Passenger_Area	561566	female	CJUR2	Dash	561605	female
C_USB1_l	Passenger_Area	561690	male	CL350	Cond_Cmpt	562251	male
C_USB1_m	Passenger_Area	563025	male	CP1	PassengerArea	561782	male
C_USB1_f	Passenger_Area	561566	female	CP1	PassengerArea	561781	female
C_USB1_f	Passenger_Area	561690	male	CP2	PassengerArea	561782	male
C_USB1_f	Passenger_Area	561566	female	CP2	PassengerArea	561781	female
C_USB1_f	Passenger_Area	561690	male	CP3	PassengerArea	561782	male
C_USB1_s	Passenger_Area	561566	female	CP3	PassengerArea	561781	female
C_USB1_s	Passenger_Area	561690	male	CP4	PassengerArea	561782	male
C_USB2	Passenger_Area	563025	male	CP4	PassengerArea	561781	female
C_USB_1	Passenger_Area	563025	male	CP_LH	RrSeat	563601	male
C_USB_F.	Passenger_Area	561566	female	CP_LH	RrSeat	563600	female
C_USB_F.	Passenger_Area	561690	male	CP_RH	RrSeat	563601	male
C_USB_LH	RrSeat	561690	male	CP_RH	RrSeat	563600	female
C_USB_LH	RrSeat	561566	female	CPUP2	Dash	560898	male
C_USB_R.	Passenger_Area	561566	female	CPUP2	Dash	560900	female
C_USB_R.	Passenger_Area	561690	male	CPUP3	Dash	560898	male
C_USBF_f	Passenger_Area	561566	female	CPUP3	Dash	560900	female
C_USBF_f	Passenger_Area	561690	male	CPUP5	Dash	560898	male
C_USBR_f	Passenger_Area	561566	female	CPUP5	Dash	560900	female
C_USBR_f	Passenger_Area	561690	male	CRadio	P.RackLH	565922	male
CB_PR	P.RackLH	564238	male	CSw34	FrontRH	563815	male
CB_RS	RJBBreakersPanel	564238	male	CSw34	FrontRH	563832	female
CCust	RJB	562477	male	CSX1	EngineCmpt.	563135	male
CCust	RJB	562479	female	CSX1	EngineCmpt.	563134	female
CF_RS	Rear_Seat	564238	male	CSX3	EngineCmpt.	563135	male
CIND-1.A	ParcelRack	560908	female	CSX3	EngineCmpt.	563134	female
CIND-1.B	ParcelRack	560908	female	CT	FrontAxle	563869	female
CIND-2.A	ParcelRack	560908	female	CT_Fr	FrontAxle	560167	male
CIND-2.B	ParcelRack	560908	female	CT_Fr	FrontAxle	560159	female

# CONNECTORS LIST

No	Location	Part #	Gender	No	Location	Part #	Gender
CT_Rr	RJB	560167	male	L38	Parcel_Rack	560898	male
CT_Rr	RJB	560159	female	L39	Parcel_Rack	560898	male
CVIP	Dash	568085	male	L40	Parcel_Rack	560898	male
CXC1	Service_Cmpt	562477	male	L41	Parcel_Rack	560898	male
CXC1	Service_Cmpt	562479	female	L42	Parcel_Rack	560898	male
EIA	EngineCmpt.	563739	male	L43	Parcel_Rack	560898	male
L.21	FrontRoof	560605	female	L44	Parcel_Rack	560898	male
L.22	FrontRoof	560605	female	L45	Parcel_Rack	560898	male
L.23	FrontRoof	560605	female	L46	Parcel_Rack	560898	male
L.24	FrontRoof	560605	female	L47	Parcel_Rack	560898	male
L.25	FrontRoof	560605	female	L48	Parcel_Rack	560898	male
L.26	FrontRoof	560605	female	L49	Parcel_Rack	560898	male
L.27	FrontRoof	560605	female	L50	Parcel_Rack	560898	male
L.84	FrontRoof	560605	female	L51	Parcel_Rack	560898	male
L.85	FrontRoof	560605	female	L52	Passenger_Area	560898	male
L.86	FrontRoof	560605	female	L52	Passenger_Area	560900	female
L.87	FrontRoof	560605	female	L53	Passenger_Area	560898	male
L.88	FrontRoof	560605	female	L53	Passenger_Area	560900	female
L.89	FrontRoof	560605	female	L54	Passenger_Area	560898	male
L.90	FrontRoof	560605	female	L54	Passenger_Area	560900	female
L15	Front_Roof	561247	male	L55	Passenger_Area	560898	male
L16.A	FrontRoof	562615	female	L55	Passenger_Area	560900	female
L16.B	FrontRoof	562615	female	L56	Passenger_Area	560898	male
L17.A	Frontroof	562615	female	L56	Passenger_Area	560900	female
L17.B	FrontRoof	562615	female	L57	Passenger_Area	560898	male
L18.A	FrontRoof	562615	female	L57	Passenger_Area	560900	female
L18.B	FrontRoof	562615	female	L58	Passenger_Area	560898	male
L19	StepCmpt	562549	male	L58	Passenger_Area	560900	female
L20	StepCmpt	562549	male	L59A	OutsideFrontRH	563866	male
L20A	StepCmpt	562486	female	L59B	OutsideFrontRH	563865	female
L28	Parcel_Rack	560898	male	L60A	OutsideFrontLH	563866	male
L29	Parcel_Rack	560898	male	L60B	OutsideFrontLH	563865	female
L30	Parcel_Rack	560898	male	L61	OutsideFrontRH	562601	male
L30A.A	ParcelRack	560898	male	L62	OutsideFrontLH	562601	male
L30AA.A	ParcelRack	560898	male	L63	OutsideFrontRH	562155	male
L30BB.A	ParcelRack	560898	male	L64	OutsideFrontRH	562155	male
L31	Parcel_Rack	560898	male	L65	OutsideFrontLH	562155	male
L32	Parcel_Rack	560898	male	L66	OutsideFrontLH	562155	male
L33	Parcel_Rack	560898	male	L67	OutsideCenterRH	562155	male
L34	Parcel_Rack	560898	male	L68	OutsideCenterRH	562155	male
L35	Parcel_Rack	560898	male	L69	OutsideCenterLH	562155	male
L36	Parcel_Rack	560898	male	L70	OutsideCenterLH	562155	male
L37	Parcel_Rack	560898	male	L71A	RearVehicle	562601	male

# CONNECTORS LIST

No	Location	Part #	Gender	No	Location	Part #	Gender
L72	RrSideLH	562155	male	L184	ServiceCmpt	561247	male
L73A	RearVehicle	562601	male	L185.A	Service_Cmpt	562651	female
L74	RrSideRH	562155	male	L185.B	Service_Cmpt	562290	female
L75	RrSideLH	562155	male	L186.A	Dash	562651	female
L76	RrSideRH	562155	male	L186.B	Dash	562290	female
L77A	RearVehicle	562601	male	L187	Engine_Cmpt	561690	male
L78A	RearVehicle	562601	male	L188	Service_Cmpt	562486	female
L79A	RearVehicle	562601	male	L189	UpperFront	564513	female
L80A	RearVehicle	562601	male	L190	Dash	564513	female
L81.A	RearVehicle	562835	female	L199	EngineCmpt	562848	male
L81.B	RearVehicle	562834	male	L203	RH_Console	561690	male
L82A	RearVehicle	562348	female	L204	Parcel_Rack_RH	562803	male
L83A	RearVehicle	562348	female	L205	EngineCmpt	562485	male
L91A	RearVehicle	562601	male	L206	Parcel_Rack_RH	562803	male
L92A	RearVehicle	562601	male	L207.A	3rdLuggCmpt	561699	female
L130.A	RrAxleCmpt	561690	male	L207.B	3rdLuggCmpt	561701	female
L130.B	RrAxleCmpt	561690	male	L207.C	3rdLuggCmpt	561701	female
L131	RrAxleCmpt	561690	male	L207.D	3rdLuggCmpt	561699	female
L145	Parcelrack	562756	male	L207.E	3rdLuggCmpt	561701	female
L146	ParcelRackLH	562756	male	L207.F	3rdLuggCmpt	561699	female
L147	ParcelRackLH	562756	male	L207.G	3rdLuggCmpt	561699	female
L148	ParcelRackLH	562756	male	L207.H	3rdLuggCmpt	560926	female
L149	ParcelRackLH	562756	male	L207.I	3rdLuggCmpt	560926	female
L150	ParcelRackLH	562756	male	L212	ParcelRackLH	563589	male
L151	ParcelRackLH	562756	male	L213	ParcelRackLH	563589	male
L152	ParcelRackLH	562756	male	L214	ParcelRackLH	563589	male
L153	ParcelRackLH	562756	male	L243	ParcelRackRH	562756	male
L154	ParcelRackLH	562756	male	L244	ParcelRackRH	562756	male
L155	ParcelRackLH	562756	male	L245	ParcelRackRH	562756	male
L156	ParcelRackLH	562756	male	L246	ParcelRackRH	562756	male
L157	ParcelRackLH	562756	male	L247	ParcelRackRH	562756	male
L158	ParcelRackLH	562756	male	L248	ParcelRackRH	562756	male
L173	EngineCmpt	563590	female	L249	ParcelRackRH	562756	male
L174A	EngineCmpt	563590	female	L250	ParcelRackRH	562756	male
L175	CondCmpt	563590	female	L251	ParcelRackRH	562756	male
L176	3rd_Lugg_Cmpt	561247	male	L252	ParcelRackRh	562756	male
L177	3rd_Lugg_Cmpt	561247	male	L253	ParcelRackRH	562756	male
L177A	WCL_Lugg_Door	561690	male	L254	ParcelRackRH	562756	male
L177B	WCL_Lugg_Door	561690	male	L255	ParcelRackRH	562756	male
L180	2nd_Lugg_Cmpt	561247	male	L256	ParcelRackRH	562756	male
L181	2nd_Lugg_Cmpt	561247	male	L280	Driver_Area	561690	male
L182	1st_Lugg_Cmpt	561247	male	L282	3rd_LH_Lugg_Cmpt	561690	male
L183	1st_Lugg_Cmpt	561247	male	L283	Service_Cmpt	562485	male

# CONNECTORS LIST

No	Location	Part #	Gender	No	Location	Part #	Gender
L285.A	Rear_Vehicle	562835	female	R14	WCLCmpt	564496	male
L285.B	Rear_Vehicle	562834	male	R15	RJB	563616	female
L286.A	Rear_Vehicle	562835	female	R16	RJB	563616	female
L286.B	Rear_Vehicle	562834	male	R21	FJB	560525	male
L298A	EngineCmpt	563590	female	R26	Evap_Cmpt	564496	male
L301	Dash	560898	male	R27	RHConsole	564496	male
L303	EngineCmpt	563590	female	R28	RrSeat	563409	male
L304	EngineCmpt	563590	female	R29	RJB	563409	male
L305.H	Enginecmpt	563764	female	R30	FJB	564496	male
L305.P	Enginecmpt	562477	male	R31	FJB	564496	male
L306	RJBCmpt	561247	male	R34	RJB	564210	male
L310	FrInterRoof	560898	male	R36	FJB	564496	male
L310A	FrInterRoof	561552	female	R37	FJB	564496	male
L350.A	RrAxleCmpt	564552	male	R44	P.RackFrLH	564496	male
L350.B	RrAxleCmpt	563340	male	R45	P.RackFrLH	564496	male
L350.C	RrAxleCmpt	562251	male	R47	WCLCmpt	564496	male
L391	Parcel_Rack	560898	male	R50	FJB	564496	male
Mo3	Dash	561667	female	R51	P.RackFrLH	564496	male
Mo4	Dash	564161	male	R52	P.RackFrLH	564496	male
Mo7	CondCmpt	561890	male	R55	FJB	564496	male
Mo8	CondCmpt	561890	male	R57	RJB	564496	male
Mo10	P.RackLH	561515	male	R65	P.RackFrLH	564496	male
Mo11	P.RackRH	561515	male	R66	P.RackFrLH	564496	male
Mo12	EvapCmpt	561690	male	R210	Parcel_Rack_LH	560525	male
Mo17	Service_Cmpt	563626	male	Res2	Parcel_Rack_JB	563205	male
Mo19	Service_Cmp	562474	male	Res3.A	ParcelRack	563590	female
Mo20	Service_Cmpt	562474	male	Res4	RH_Console	563590	female
Mo22	RH_Console	561186	male	Res6	RJB	563590	female
Mo27	CondCmpt	561890	male	Res7	Dash	563590	female
Mo28	CondCmpt	561890	male	Res14	Evap_Cmpt	563205	male
Mo29	RJB	563590	female	Res15	EngineCmpt	561782	male
Mo37	ServiceCmpt	562477	male	Res20	Parcel_Rack	563590	female
Mo38	WCLUperDoor	564161	male	Res31	UreaCmpt	562350	male
Mo65	EngineCmpt	568089	male	Res32	UreaCmpt	563764	female
Mo67	EngineCmpt	568089	male	Res37.A	Front_Clearance	561690	male
Mo68	EngineCmpt	568089	male	Res37.B	Front_Clearance	561690	male
Mo69	EngineCmpt	568089	male	Res46	RrAxleCmpt	563590	female
Mo70	EngineCmpt	568089	male	Res53	Dash	563590	female
Mo71	EngineCmpt	568089	male	RT34.1	FJB	561904	female
Mo72	EngineCmpt	568089	male	RT34.2	FJB	561904	female
Mo73	EngineCmpt	568089	male	RT34.3	FJB	561904	female
R1	R1	562486	female	Se2	LH_Console	561566	female
R3	RJB	563409	male	Se11.A	Cond_Cmpt	564460	female
R12	Evap_Cmpt	563409	male	Se11.B	Cond_Cmpt	564460	female
R13	WCLCmpt	564496	male	Se11.C	Cond_Cmpt	564460	female

# CONNECTORS LIST

No	Location	Part #	Gender	No	Location	Part #	Gender
Se13	Engine_Cmpt	562350	male	Se79	Front_Axle	563340	male
Se14.A	Driver_Area	561782	male	Se83	FrontAxle	642190	female
Se14.B	Driver_Area	561781	female	Se84	FrontAxle	642190	female
Se18	PneuPlate	561566	female	Se85	RearAxle	642190	female
Se19_P	Service_Cmpt	563677	male	Se86	RearAxle	642190	female
Se19_S	ServiceCmpt	563677	male	Se87	RearAxle	642190	female
Se20	Head_Lamp_RH	562426	male	Se88	RearAxle	642190	female
Se21	Dash	561248	female	Se89	EngineCmpt	562350	male
Se22	CondCmpt	562877	female	Se94	WCLUpperdoor	562877	female
Se23	Engine_Cmpt	563159	male	Se100	WCLUpperdoor	562479	female
Se24	EvapCmpt	563758	female	shell1	RJB	561932	male
Se25	Passenger_Area	561248	female	shell1_1	Luggage_Cmpt	561690	male
Se29	Engine_Cmpt	561566	female	So4	RH_Console	641385	male
Se30	EngineCmpt	562877	female	So5	RH_Console	641385	male
Se31	EngineCmpt	562877	female	So6	RH_Console	641385	male
Se32	Rear_Axle_Cmpt	562426	male	So7	Service_Cmpt	561566	female
Se33	Rear_Axle_Cmpt	562856	male	So8	ServiceCmpt	641385	male
Se34	Rear_Axle_Cmpt	562426	male	So9	EngineCmpt	560016	female
Se35	Rear_Axle_Cmpt	562426	male	So10	CondCmpt	562485	male
Se36	Rear_Axle_Cmpt	562427	male	So11	Cond_Cmpt	561566	female
Se37	Front_Axle_LH	641132	female	So13	Evap_Cmpt	563204	female
Se38	Front_Axle_RH	641132	female	So15	PneuPlate	641385	male
Se39	Rear_Axle_LH	641132	female	So16	PneuPlate	641385	male
Se40	Rear_Axle_LH	641132	female	So17	PneuPlate	562848	male
Se45.A	ServiceCmpt	563409	male	So20	PneuPlate	641385	male
Se49	Engine_Cmpt	561690	male	So21	Front_Axle_Cmpt	564046	female
Se50.A	FJB	561904	female	So22	Front_Axle_Cmpt	564046	female
Se50.B	FJB	561904	female	So23	Rear_Axle_Cmpt	564046	female
Se51	FJB	563589	male	So24	Rear_Axle_Cmpt	564046	female
Se53	Service_Cmpt	563159	female	So27	RearAxleCmpt	564045	female
Se54	Service_Cmpt	563159	female	So29	WCLCmpt	641385	male
Se55	Service_Cmpt	563159	female	So50	RearAxleCmpt	564046	female
Se56	WCLCmpt.	562479	female	So52	FrontAxleCmpt	564045	female
Se62	WCLLuggDoor	561690	male	So53	Rear_Axle_Cmpt	641385	male
Se63	EngineCmpt	641132	female	So55	PneuPlate	562848	male
Se64	EngineCmpt	641132	female	So70	PneumaticPanel	641385	male
Se65	Dash	564042	female	spBar2	Engine_Cmpt	564135	male
Se66	FrontAxle	564039	female	spBar3	Parcel_Rack_LH	564135	male
Se67	FJB	563159	female	spBar4	EngineCmpt	564135	male
Se69	FJB	563159	female	spBar5	EngineCmpt	564135	male
Se76	EntranceDoor	562479	female	spBar6	EngineCmpt	564135	male
Se77	FrontVehicle	563159	female	spBar7	UreaCmpt	564135	male
Se78	PneuPlate	563159	female	spBar11	RearVehicle	564135	male

# CONNECTORS LIST

No	Location	Part #	Gender	No	Location	Part #	Gender
spBar12	RearVehicle	564135	male	Spk23.A	FroutsideLH	563994	male
spBar13	EngineCmpt	564135	male	Spk23.B	FroutsideRH	563996	female
spBar14	EngineCmpt	564135	male	Spk24	Froutsidecenter	563994	male
spBar15	EngineCmpt	564135	male	Spk25	Froutsidecenter	563994	male
spBar16	EngineCmpt	564135	male	Sw2	Dash	562763	male
spBar19	CondensorCmpt	564135	male	Sw4	Dash	562763	male
spBar20	CondensorCmpt	564135	male	Sw10A	LH_Console	562763	male
spBar21	CondensorCmpt	564135	male	Sw12	Dash	562763	male
spBar22	EngineCmpt	564135	male	Sw13	Dash	562763	male
spBar23	EngineCmpt	564135	male	Sw14	Dash	562763	male
spBar24	FJB	564135	male	Sw16	RJB	563135	male
spBar25	EngineCmpt	564135	male	Sw16	Dash	562763	male
spBar26	FrAxleCmpt	564135	male	Sw17	Dash	562763	male
spBar27	FrAxleCmpt	564135	male	Sw20	Dash	562763	male
Spk1_L	Parcel_Rack_LH	563994	male	Sw24	Dash	562763	male
Spk1_R	Parcel_Rack_RH	563994	male	Sw25	Dash	562763	male
Spk2_L	Parcel_Rack_LH	563994	male	Sw29	Dash	562763	male
Spk2_R	Parcel_Rack_RH	563994	male	Sw30	LHConsol	562763	male
Spk3_L	Parcel_Rack_LH	563994	male	Sw34	FrEntranceDoor	563832	female
Spk3_R	Parcel_Rack_RH	563994	male	Sw38	LH_Console	562763	male
Spk4_L	Parcel_Rack_LH	563994	male	Sw41	LH_Console	562749	male
Spk4_R	Parcel_Rack_RH	563994	male	Sw42	WCL_Cmpt	561635	female
Spk5_L	Parcel_Rack_LH	563994	male	Sw44.A	FJB	562403	female
Spk5_R	Parcel_Rack_RH	563994	male	Sw45.A	3rd_Lugg_Cmpt	562403	female
Spk6_L	Parcel_Rack_LH	563994	male	Sw46.A	3rd_Lugg_Cmpt	562403	female
Spk6_R	Parcel_Rack_RH	563994	male	Sw46B.A	3rdLuggCmpt.	562403	female
Spk7_L	Parcel_Rack_LH	563994	male	Sw46B.B	3rdLugg.Cmpt.	562403	female
Spk7_R	Parcel_Rack_RH	563994	male	Sw49.A	2nd_Lugg_Cmpt	562403	female
Spk8_L	Parcel_Rack_LH	563994	male	Sw50.A	2nd_Lugg_Cmpt	562403	female
Spk8_R	Parcel_Rack_RH	563994	male	Sw51.A	1st_Lugg_Cmpt	562403	female
Spk9_L	Parcel_Rack_LH	563994	male	Sw52.A	1st_Lugg_Cmpt	562403	female
Spk9_R	Parcel_Rack_RH	563994	male	Sw58	EngineCmpt.	563135	male
Spk10_L	Parcel_Rack_LH	563994	male	Sw59	EngineCmpt.	563135	male
Spk10_R	Parcel_Rack_RH	563994	male	Sw64.A	Service_Cmpt	560815	female
Spk11_L	Parcel_Rack_LH	563994	male	Sw64.B	Service_Cmpt	560815	female
Spk11_R	Parcel_Rack_RH	563994	male	Sw70	Dash	562763	male
Spk12_L	Parcel_Rack_LH	563994	male	Sw71	EngineCmpt	562348	female
Spk12_R	Parcel_Rack_RH	563994	male	Sw80A	EngineCmpt	562763	male
Spk13_L	Parcel_Rack_LH	563994	male	Sw81.A	Dash	562905	male
Spk13_R	Parcel_Rack_RH	563994	male	Sw81.B	Dash	562905	male
Spk14_L	Parcel_Rack_LH	563994	male	Sw82A	RJB	563618	male
Spk14_R	Parcel_Rack_RH	563994	male	Sw83A	Dash	562581	male
Spk22	Dash	563994	male	Sw84	EngineCmpt.	563135	male
				Sw85	LH_Console	562749	male

# CONNECTORS LIST

No	Location	Part #	Gender	No	Location	Part #	Gender
Sw95.A	WCLDoor	561626	female	Tab70b.A	ParcelRack	561626	N/A
Sw95.B	WCLDoor	561626	female	TermL152B	ParcelRackLH	562505	N/A
Sw96.A	WCL_Door	562615	female	TermL249B	ParcelRackRH	562505	N/A
Sw96.B	WCL_Door	562615	female	USB.MOD	1stseat	561690	male
Sw96.C	WCLDoor	562615	female	USB.MOD	1stseat	561566	female
Sw97.A	WCLSystem	562615	female	USB.WCL.F	PassengerArea	561690	male
Sw97.B	WCLSystem	562615	female	USB.WCL.F	PassengerArea	561566	female
Sw97.C	WCLSystem	562615	female	USB.WCL.F	PassengerArea	561690	male
Sw98.A	WCLSystem	561626	female	USB.WCL.F	PassengerArea	561566	female
Sw98.B	WCLSystem	561626	female	USB1L	PassengerArea	563025	male
Sw103	LH_Console	562763	male	USB1R	PassengerArea	563025	male
Sw105	Dash	563590	female	USB2	Passenger_Area	563025	male
Sw116.A	Luggages	560079	female	USB2L	Passenger_Area	561690	male
Sw116.B	Luggages	560079	female	USB2R	Passenger_Area	561690	male
Sw122	Dash	562763	male	USB3L	Passenger_Area	561690	male
Sw123	Dash	562763	male	USB3R	Passenger_Area	561690	male
Sw137	Dash	562763	male	USB4L	Passenger_Area	561690	male
Sw138	FJB	561690	male	USB4R	Passenger_Area	561690	male
Sw139	FJB	561690	male	USB5L	Passenger_Area	561690	male
Sw140	FJB	561566	female	USB5R	Passenger_Area	561690	male
Sw141	FJB	561690	male	USB6L	Passenger_Area	561690	male
Sw142	LHConsole	562763	male	USB6R	Passenger_Area	561690	male
Sw143	Driver_Area	562485	male	USB7L	Passenger_Area	561690	male
Sw144	FJB	561690	male	USB7R	Passenger_Area	561690	male
Sw152	Driver_Area	562471	male	USB8L	Passenger_Area	563025	male
Sw152.	Driver_Area	562471	male	USB9L	Passenger_Area	563025	male
Sw161	Dash	562763	male	USB9R	Passenger_Area	563025	male
sym691_1	Parcel_Rack_LH	562464	male	USB10L	Passenger_Area	561690	male
sym762_1	FrInterRoof	561611	male	USB10R	Passenger_Area	561690	male
sym762_1	FrInterRoof	561610	female	USB11L	Passenger_Area	561690	male
sym780_1	FrInterRoof	563040	female	USB11R	Passenger_Area	561690	male
sym781_1	FrInterRoof	563071	male	USB12L	Passenger_Area	561690	male
sym797_2	ParcelRack	565180	female	USB12R	Passenger_Area	561690	male
sym803_2	ParcelRack	565180	female	USB13L	Passenger_Area	561690	male
sym814_2	ParcelRack	565180	female	USB13R	Passenger_Area	561690	male
sym815_2	ParcelRack	565180	female	USB14L	Passenger_Area	561690	male
sym816_2	ParcelRack	565180	female	USB14R	Passenger_Area	561690	male
sym824_2	ParcelRack	565180	female	USB_Mod	Passenger_Area	561690	male
sym826_2	ParcelRack	565180	female	USB_Mod	Passenger_Area	561566	female
Tab1.A	ParcelRack	561626	N/A	USB_WCL	Passenger_Area	563025	male
tab69.A	ParcelRack	565180	N/A	VECF1	FJB	563186	male
tab70.A	ParcelRack	565180	N/A	VECF2	FJB	563183	male
Tab70a.A	ParcelRack	561626	N/A	VECF3	FJB	563185	male



# CONNECTORS LIST

No	Location	Part #	Gender	No	Location	Part #	Gender
VECF4	FJB	563182	male				
VECF9	FJB	563448	male				
VECF10	FJB	563181	male				
VECF11	FJB	563184	male				
VECF12	FJB	563187	male				
VECPR1	Parcelrack_LH	563715	male				
VECPR2	Parcelrack_LH	563716	male				
VECPR3	Parcelrack_LH	563718	male				
VECPR4	Parcelrack_LH	563714	male				
VECR1	RJB	563186	male				
VECR2	RJB	563183	male				
VECR3	RJB	563185	male				
VECR4	RJB	563182	male				
VECR9	RJB	563448	male				
VECR10	RJB	563181	male				
VECR11	RJB	563184	male				
VECR12	RJB	563187	male				
Y80	Engine_Cmpt	563789	male				
Y81	Cond_Cmpt	563793	male				

# CONNECTORS LIST

No	Location	Part #	Gender	No	Location	Part #	Gender
A1	RJB	563975	male	A78	RJB	562583	female
A2	FJB	563984	male	A79	RJB	562583	female
A3.A	dash	565910	male	A80	EngineCmpt.	562479	female
A3.B	Dash	565908	male	A81CN1	FJB	562767	male
A3.C	Dash	565909	male	A81CN3A	FJB	564741	male
A5	Service_Cmpt	562428	female	A81CN3B	FJB	564742	male
A6	Engine_Cmpt	562427	male	A83	FJB	565970	female
A7	Rear_Axle_Cmpt	563979	male	A96	FJB	564205	male
A9.Cx1	FJB	564041	female				
A9.Cx2	FJB	563678	male				
A9.Cx3	FJB	564037	male				
A9.Cx4	FJB	564038	female	A98	Upperfront	563953	male
A14A.A	Dash	562766	male	A99	FJB	564205	male
A14A.B	Dash	562767	male	A100	FrontAxle	563632	male
A14A.C	Dash	562765	male	A101	RearRH Axel	563632	male
A15	Dash	562464	male	A102	RearLH Axel	563632	male
A18.J1	FJB	562794	male	A103	Dash	562070	female
A18.J2	FJB	562650	male	A104	Dash	561606	female
A24.A	RH_Console	561890	male	A107	Parcel_rack_LH	565940	male
A24.B	RH_Console	561566	female	A108.P1	Parcel_Rack_LH	561247	male
A27	Service_Cmpt	562929	male	A108.P2	Parcel_Rack_LH	561550	male
A28	Service_Cmpt	562928	male	A110.A	InterFrRoof	562479	female
A34.7	Rad_Cmpt	564258	male	A111	Entrancedoor	561690	male
A34.J	Rad_Cmpt	568118	male	A112.X2	Parcel_Rack	bidon	male
A34.K	Rad_Cmpt	564270	male	A112.X5	Parcel_Rack	bidon	male
A34.L	Rad_Cmpt	564269	male	A112.X6	Parcel_Rack	bidon	male
A36.JA	FJB	562767	male	A112.X7	Parcel_Rack	563918	male
A36.JB	FJB	562765	male	A112.X8	Parcel_Rack	bidon	male
A36.JC	FJB	562957	male	A112.X9	Parcel_Rack	bidon	male
A37.JA	FJB	562767	male	A112.X10	Parcel_Rack	bidon	male
A37.JB	FJB	562765	male	A113.X1	Parcel_Rack	563916	male
A37.JC	FJB	562957	male	A113.X2	Parcel_Rack	bidon	male
A69L.A	P.RackLH	563025	male	A113.X3	P.RackLH	563920	male
A69L.B2	P.RackLH	bidon	male	A113.X4	P.RackLH	bidon	male
A69L.B4	P.RackLH	bidon	male	A130.	Driver_Area	563226	male
A69L.C	P.RackLH	bidon	male	A130.J1	3rd_LH_Lugg_Cmpt	563226	male
A69R.A	P.RackLH	563025	male	A130.J2	3rd_LH_Lugg_Cmpt	563227	male
A69R.B1	P.RackLH	bidon	male	A130.J4	3rd_LH_Lugg_Cmpt	563879	male
A69R.B2	P.RackLH	bidon	male	A131.A	Engine_Cmpt	561782	male
A69R.B3	P.RackLH	bidon	male	A131.B	Engine_Cmpt	561781	female
A69R.B4	P.RackLH	bidon	male	A132.A	Driver_Area	563967	male
A69R.C	P.RackLH	bidon	male	A132.B	Driver_Area	561551	female
A77	RJB	564547	male	A134.A	Engine_Cmpt	561782	male

# CONNECTORS LIST

No	Location	Part #	Gender	No	Location	Part #	Gender
A134.B	Engine_Cmpt	561781	female	AE51.J2	RJB	564037	female
A135.A	Engine_Cmpt	561782	male	AE51.J3	RJB	565957	male
A135.B	Engine_Cmpt	561781	female	AE52.J1	RJB	563679	male
A136.A	Engine_Cmpt	561782	male	AE52.J2	RJB	564037	female
A136.B	Engine_Cmpt	561781	female	AE52.J3	RJB	565957	male
A138	CondensorCmpt.	563787	male	AE53.J1	RJB	563679	male
A139.A	3rd_LH_Lugg_Cmpt	561782	male	AE53.J2	RJB	564037	female
A139.B	3rd_LH_Lugg_Cmpt	561781	female	AE53.J3	RJB	565957	male
A139.C	3rd_LH_Lugg_Cmpt	565158	female	AE54.J1	EvaporatorCmpt.	563679	male
A140	Driver_Area	563226	male	AE54.J2	EvaporatorCmpt.	564037	female
A160.A	LuggCmpt	562477	male	AE54.J3	CondensorCmpt.	565957	male
A160.B	LuggCmpt	562884	female	AE55.J1	Dash	563679	male
AE41.J1	FJB	563679	male	AE55.J2	Dash	564037	female
AE41.J2	FJB	564037	female	AE55.J3	Dash	564004	male
AE41.J3	FJB	564004	male	AE56.J1	Dash	563679	male
AE42.J1	FJB	563679	male	AE56.J2	Dash	564037	male
AE42.J2	FJB	564037	female	AE56.J3	Dash	564004	male
AE42.J3	FJB	564004	male	AE57.J1	WCLCmpt.	563679	male
AE43.J1	FJB	563679	male	AE57.J2	WCLCmpt.	564037	male
AE43.J2	FJB	564037	male	AE57.J3	WCLCmpt.	564004	male
AE43.J3	FJB	565957	male	Alt_LR.A	EngineCmpt.	563746	female
AE44.J1	FJB	563679	male	Alt_LR.B	EngineCmpt.	560815	female
AE44.J2	FJB	564037	female	Alt_LR.C	EngineCmpt.	564469	female
AE44.J3	FJB	565957	male	Alt_UR.A	EngineCmpt.	563746	female
AE45.J1	FJB	563679	male	Alt_UR.B	EngineCmpt.	560815	female
AE45.J2	FJB	564037	female	Alt_UR.C	EngineCmpt.	564469	female
AE45.J3	FJB	565957	male	AltLL.A	EngineCmpt.	563746	female
AE46.J1	FJB	563679	male	AltLL.B	EngineCmpt.	560815	female
AE46.J2	FJB	564037	female	AltLL.C	EngineCmpt.	564469	female
AE46.J3	FJB	565957	male	B85	EngineCmpt	563815	male
AE47.J1	RHConsole	563679	male	B96	EngineCmpt	563821	male
AE47.J2	RHConsole	564037	female	B96B	EngineCmpt	563823	male
AE47.J3	RHConsole	565957	male	B97	EngineCmpt	563816	male
AE48.J1	RHConsole	563679	male	B98	EngineCmpt	563817	male
AE48.J2	RHConsole	564037	female	B99	EngineCmpt	563815	male
AE48.J3	RHConsole	565957	male	B115A	EngineCmpt.	564226	male
AE49.J1	RJB	563679	male	B142C	EngineCmpt.	563793	male
AE49.J2	RJB	564037	male	B310	EngineCmpt.	565967	male
AE49.J3	RJB	565957	male	C.243	ServiceCmpt.	562789	male
AE50.J1	RJB	563679	male	C.243	ServiceCmpt.	565131	female
AE50.J2	RJB	564037	male	C1	FJB	563589	male
AE50.J3	RJB	565957	male	C1	FJB	563590	female
AE51.J1	RJB	563679	male	C1A	FJB	561611	male

# CONNECTORS LIST

No	Location	Part #	Gender	No	Location	Part #	Gender
C1A	FJB	561610	female	C18	FJB	561986	male
C1B	Parcel_Rack_LH	561611	male	C18	FJB	561987	female
C1B	Parcel_Rack_LH	561610	female	C19	RJB	561986	male
C1S	FJB	563589	male	C19	RJB	561987	female
C1S	FJB	563590	female	C20A	AFSS	562485	male
C2	Service_Cmpt	563580	male	C20A	AFSS	562486	female
C2	Service_Cmpt	563581	female	C20B	Evap_Cmpt	562485	male
C2A	FJB	563580	male	C20B	Evap_Cmpt	562486	female
C2A	FJB	563581	female	C23	Evap.Cmpt.	564034	male
C2bb	FJB	564034	male	C23	Evap.Cmpt.	564035	female
C2bb	FJB	564035	female	C24_plug	Evap_Cmpt	561690	male
C3_plug	RJB	563589	male	C24_sock	Evap_Cmpt	561566	female
C3_socket	RJB	563590	female	C25	Parcel_Rack_LH	561550	male
C3S	RJB	563593	male	C25	Parcel_Rack_LH	561667	female
C3S	RJB	563590	female	C25.	Parcel_Rack_LH	561669	male
C4	FJB	563580	male	C25.	Parcel_Rack_LH	561670	female
C4	FJB	563581	female	C25A	ParcalrackLH	561515	male
C5	FJB	563589	male	C25A	ParcelRackLH	561552	female
C5	FJB	563590	female	C25A.	ParcalrackLH	561669	male
C5S	FJB	563589	male	C25A.	ParcalrackLH	561670	female
C5S	FJB	563590	female	C26	UreaCmpt.	563226	male
C6	FJB	563582	male	C26	UreaCmpt.	563613	female
C6	FJB	563583	female	C26A	UreaCmpt.	568110	male
C9	RJB	561986	male	C26A	UreaCmpt.	568109	female
C9	RJB	561987	female	C26B	UreaCmpt.	563227	male
C10	Engine_Cmpt	562477	male	C26B	UreaCmpt.	563614	female
C10	Engine_Cmpt	562479	female	C29	3rd_Lugg_Cmpt	563651	male
C11	Service_Cmpt	563580	male	C29	3rd_Lugg_Cmpt	563652	female
C11	Service_Cmpt	563581	female	C30	3rd_Lugg_Cmpt	561710	male
C12	Engine_Cmpt	562581	male	C30	3rd_Lugg_Cmpt	561709	female
C12	Engine_Cmpt	562583	female	C31W	3rdLuggCmpt.	563227	male
C13_plug	RH_Console	563589	male	C31W	3rdLuggCmpt.	563614	female
C13_socket	RH_Console	563590	female	C32W	WCLCmpt.	561640	male
C13S	RH_Console	563589	male	C32W	WCLCmpt.	561639	female
C13S	RH_Console	563590	female	C33	WCLCmpt.	564034	male
C14	RJB	561986	male	C33	WCLCmpt.	564035	female
C14	RJB	561987	female	C33W	WCLCmpt.	562477	male
C15A	EvapCmpt	568110	male	C33W	WCLCmpt.	562479	female
C15A	EvapCmpt	568109	female	C34	RH_Console	561986	male
C16	RJB	561577	male	C34	RH_Console	561987	female
C16	RJB	561605	female	C35	WCLdoor	562485	male
C17	RJB	560195	male	C35	WCLdoor	562486	female
C17	RJB	560169	female	C36	FJB	561986	male

# CONNECTORS LIST

No	Location	Part #	Gender	No	Location	Part #	Gender
C36	FJB	561987	female	C62	Fr_Service_Door	562566	male
C37	Parcel_Rack_LH	562557	male	C62	Fr_Service_Door	562565	female
C37	Parcel_Rack_LH	562558	female	C64	EngineCmpt.	568110	male
C37.	Parcel_Rack_LH	561734	male	C64	EngineCmpt.	568109	female
C37.	Parcel_Rack_LH	561735	female	C68	P.RackLH	561646	male
C38	ParcelRackLH	562555	male	C68	P.RackLH	561644	female
C38	ParcelRackLH	562556	female	C70	FJB	561646	male
C38.	ParcelRackLH	561734	male	C70	FJB	561645	female
C38.	ParcelRackLH	561735	female	C70B	FJB	561710	male
C39A	Engine_Cmpt	561782	male	C70B	FJB	561989	female
C39A	Engine_Cmpt	561781	female	C71	FJB	561646	male
C40	Dash	562485	male	C71	FJB	561645	female
C40	Dash	562486	female	C72	FJB	561646	male
C44_plug	FJB	561577	male	C72	FJB	561645	female
C44_socket	FJB	561605	female	C74	FJB	561710	male
C45	FJB	561643	male	C74	FJB	561989	female
C45	FJB	561642	female	C77	FJB	562350	male
C46	WCLCmpt.	564228	male	C77	FJB	563764	female
C46	WCLCmpt.	564229	female	C79	RJB	561986	male
C50	RJB	563931	male	C79	RJB	561987	female
C50	RJB	563930	female	C81_plug	1stLuggCmpt.	562477	male
C51	Engine_Cmpt	561932	male	C81_socket	1stLuggCmpt.	562479	female
C51	Engine_Cmpt	560933	female	C82	1stLuggCmpt.	562581	male
C52	Evap.Cmpt.	563618	male	C82	2ndLuggCmpt.	562583	female
C52	Evap.Cmpt.	563616	female	C83_plug	2ndLuggCmpt.	562477	male
C54	EngineCmpt.	563226	male	C83_socket	2ndLuggCmpt.	562479	female
C54	EngineCmpt.	563613	female	C84_plug	2ndLuggCmpt.	562477	male
C54A	EngineCmpt.	568110	male	C84_socket	2ndLuggCmpt	562479	female
C54A	EngineCmpt.	568109	female	C85_plug	3rdLuggCmpt.	562477	male
C54B	EngineCmpt.	563589	male	C85_socket	3rdLuggCmpt.	562479	female
C54B	EngineCmpt.	563590	female	C86	3rdLuggCmpt.	563618	male
C56	3rd_LH_Lugg_Cmpt	561643	male	C86	3rdLuggCmpt.	563616	female
C56	3rd_LH_Lugg_Cmpt	561642	female	C87	Engine_Cmpt	562485	male
C57	3rd_LH_Lugg_Cmpt	561782	male	C87	Engine_Cmpt	562486	female
C57	3rd_LH_Lugg_Cmpt	561781	female	C88	WCLCmpt.	563227	male
C57A	Engine_Cmpt	561690	male	C88	WCLCmpt.	563614	female
C57A	Engine_Cmpt	561566	female	C91	RJB	564619	male
C58	CondensorCmpt.	564567	male	C91	RJB	562282	female
C58	CondensorCmpt.	564568	female	C92A	EngineCmpt.	563226	male
C59	LuggCmpt.	561646	male	C92A	EngineCmpt.	563613	female
C59	LuggCmpt.	561645	female	C92B	EngineCmpt.	562581	male
C61	Fr_Service_Door	561669	male	C92B	EngineCmpt.	562583	female
C61	Fr_Service_Door	561670	female	C92C	EngineCmpt.	562581	male

# CONNECTORS LIST

No	Location	Part #	Gender	No	Location	Part #	Gender
C92C	EngineCmpt.	562583	female	C171	LH_Console	561646	male
C94_plug	FJB	563589	male	C171	LH_Console	561645	female
C94_socket	FJB	563590	female	C175	RJB	563226	male
C95	FJB	561646	male	C175	RJB	563613	female
C95	FJB	561645	female	C193_r	RJB	563589	male
C96	FJB	561643	male	C193_s	RJB	563590	female
C96	FJB	561642	female	C194	FJB	563589	male
C97	FJB	561643	male	C194	FJB	563590	female
C97	FJB	561642	female	C206	Parcel_Rack_RH	562503	male
C98	2nd_LH_Lugg_Cmpt	562581	male	C206	Parcel_Rack_RH	562507	female
C98	2nd_LH_Lugg_Cmpt	562583	female	C207	Parcel_Rack_LH	562503	male
C99	2nd_RH_Lugg_Cmpt	562581	male	C207	Parcel_Rack_LH	562507	female
C99	2nd_RH_Lugg_Cmpt	562583	female	C213	Parcel_Rack_LH	561515	male
C100	EvapCmpt.	562477	male	C213	Parcel_Rack_LH	561552	female
C100	EvapCmpt.	562479	female	C223	FJB	563227	male
C100S	EvapCmpt.	562477	male	C223	FJB	563614	female
C100S	EvapCmpt.	562479	female	C226	FJB	562650	male
C101	Service_Cmpt	561690	male	C226	FJB	562649	female
C101	Service_Cmpt	561566	female	C227	FJB	562650	male
C102A	CondensorCmpt.	563226	male	C227	FJB	562649	female
C102A	CondensorCmpt.	563613	female	C229	Dash	561782	male
C104S_plug	LuggCmpt.	563589	male	C229	Dash	561781	female
C104S_socket	LuggCmpt.	563590	female	C230	FrontInterRoof	562477	male
C110	PneumaticPanel	568110	male	C230	FrontInterRoof	562479	female
C110	PneumaticPanel	568109	female	C231	FJB	563409	male
C115	FrInterRoof	561690	male	C231	FJB	563410	female
C115	FrInterRoof	561566	female	C242	Service_Cmpt	562789	male
C116	FrInterRoof	561611	male	C242	Service_Cmpt	565131	female
C116	FrInterRoof	561610	female	C243	ServiceCmpt.	563347	male
C117	Parcel_Rack_LH	561690	male	C243	ServiceCmpt.	563180	female
C117	Parcel_Rack_LH	561566	female	C259	LuggCmpt	561637	male
C119	EngineDoor	568110	male	C259	LuggCmpt	561636	female
C119	EngineDoor	568109	female	C266	Parcelrack	561782	male
C121	EngineDoor	563347	male	C266	Parcelrack	561781	female
C121	EngineDoor	563180	female	C267	Parcelrack	561782	male
C122	EngineDoor	568118	male	C267	Parcelrack	561781	female
C122	EngineDoor	562531	female	C279	Service_Cmpt	562477	male
C144	ParcelRackJB	560852	male	C279	Service_Cmpt	562479	female
C144	ParcelRackJB	560851	female	C284	Parcel_Rack_LH	561247	male
C152	Cond_Cmpt	561611	male	C284	Parcel_Rack_LH	561248	female
C152	Cond_Cmpt	561610	female	C284_1	Parcel_Rack_LH	561247	male
C158	CondCmpt.	562477	male	C284_1	Parcel_Rack_LH	561248	female
C158	CondCmpt.	562479	female	C284_2	Parcel_Rack_LH	561247	male

# CONNECTORS LIST

No	Location	Part #	Gender	No	Location	Part #	Gender
C284_2	Parcel_Rack_LH	561248	female	C577A	Parcel_Rack	562006	male
C284_3	Parcel_Rack_LH	561247	male	C577A	Parcel_Rack	560908	female
C284_3	Parcel_Rack_LH	561248	female	C577AA	ParcelRack	562006	male
C284_4	Parcel_Rack_LH	561247	male	C577AA	ParcelRack	560908	female
C284_4	Parcel_Rack_LH	561248	female	C578	ParcelRackJB	562503	male
C284_5	Parcel_Rack_LH	561247	male	C578	ParcelRackJB	562507	female
C284_5	Parcel_Rack_LH	561248	female	C579	P.RackLH	562549	male
C349	Engine_Cmpt	565170	male	C579	P.RackLH	562550	female
C350	Engine_Cmpt	565170	male	C_ALT	EngineCmpt.	562581	male
C355	RJB	563582	male	C_ALT	EngineCmpt.	562583	female
C355	RJB	563583	female	C_ALT3	EngineCmpt.	562477	male
C356	ParcelRackJB	561710	male	C_ALT3	EngineCmpt.	562479	female
C356	ParcelRackJB	561709	female	C_BCIS_BHS	P.RackLH	561643	male
C357	P.RackJCB	564294	male	C_BCIS_BHS	P.RackLH	561641	female
C357	P.RackJCB	564295	female	C_BCIS_IFU	P.RackLH	562650	male
C358	P.RackLH	566033	male	C_BCIS_IFU	P.RackLH	562649	female
C358	P.RackLH	566034	female	C_BCIS_ODK	P.RackLH	562650	male
C380A	Dash	564222	male	C_BCIS_ODK	P.RackLH	562649	female
C380A	Dash	564224	female	C_BCIS_PWR	P.RackLH	561550	male
C397	RJB	562285	male	C_BCIS_PWR	P.RackLH	561667	female
C397	RJB	562282	female	C_BCIS_RDR	P.RackLH	565940	male
C463	EngineCmpt	568112	male	C_BCIS_SIG	P.RackLH	561690	male
C463	EngineCmpt	568111	female	C_BCIS_SIG	P.RackLH	561566	female
C464A	RJB	564222	male	C_BCIS_SW	P.RackLH	561637	male
C464A	RJB	564224	female	C_BCIS_SW	P.RackLH	561636	female
C465	Parcelrack	562581	male	C_BCIS_SW1	P.RackLH	561637	male
C465	Parcelrack	562583	female	C_BCIS_SW1	P.RackLH	561636	female
C466	LH_Consol	562503	male	C_Bike_Se	Front_Axle	562901	male
C466	LH_Consol	562507	female	C_Bike_Se	Front_Axle	562902	female
C574	P.RackRH	562549	male	C{EIF	Engine_Cmpt	563135	male
C574	P.RackRH	562550	female	C{EIF	Engine_Cmpt	563134	female
C575	ParcelRackRH	562503	male	C_Foot	FJB	563347	male
C575	ParcelRackRH	562507	female	C_Foot	FJB	563180	female
C576	Parcel_Rack_RH	561515	male	C_INV1	ParcelRack	562337	male
C576	Parcel_Rack_RH	561552	female	C_INV1	ParcelRack	562338	male
C576A	Parcel_Rack_RH	561515	male	C_INV2_1	ParcelRack	562337	male
C576A	Parcel_Rack_RH	561552	female	C_INV2_1	ParcelRack	562338	male
C576B	Parcel_Rack_RH	562006	male	C_INV2_2	ParcelRack	562337	male
C576B	Parcel_Rack_RH	560908	female	C_INV2_2	ParcelRack	562338	female
C576BB	ParcelRack	562006	male	C_INV3	ParcelRack	562337	male
C576BB	ParcelRack	560908	female	C_INV3	ParcelRack	562338	female
C577	Parcel_Rack	561515	male	C_JP_FBOX	Parcel_Rack_LH	561782	male
C577	Parcel_Rack	561552	female	C_JP_FBOX	Parcel_Rack_LH	561781	female

# CONNECTORS LIST

No	Location	Part #	Gender	No	Location	Part #	Gender
C_JP_Rad	Parcel_Rack_LH	561782	male	CIND1.A	ParcelRack	560908	female
C_JP_Rad	Parcel_Rack_LH	561781	female	CIND1.B	ParcelRack	560908	female
C_Mo9_p	Evap_Cmpt	561577	male	CIND_1.A	ParcelRack	560908	female
C_Mo9_s	Evap_Cmpt	561605	female	CIND_1.B	ParcelRack	560908	female
C_MVIEW	ParcelRackLH	563227	male	CINDWC-1.A	ParcelRack	560908	female
C_MVIEW	ParcelRackLH	563614	female	CINDWC-1.B	ParcelRack	560908	female
C_MVIEW	ParcelRackLH	39-01-214	male	CJUP1	Dash	560898	male
C_MVIEW	ParcelRackLH	39-01-214	female	CJUP1	Dash	560900	female
C_MVIEW	ParcelRackLH	562779	male	CJUP4	Dash	560898	male
C_MVIEW	ParcelRackLH	562465	male	CJUP4	Dash	560900	female
C_MVIEW	ParcelRackLH	562842	male	CJUR1	Dash	562485	male
C_USB1_f	Passenger_Area	561566	female	CJUR1	Dash	562486	female
C_USB1_f	Passenger_Area	561690	male	CJUR2	Dash	561577	male
C_USB1_l	Passenger_Area	561566	female	CJUR2	Dash	561605	female
C_USB1_l	Passenger_Area	561690	male	CL350	Cond_Cmpt	562251	male
C_USB1_m	Passenger_Area	563025	male	CP1	PassengerArea	561782	male
C_USB1_f	Passenger_Area	561566	female	CP1	PassengerArea	561781	female
C_USB1_f	Passenger_Area	561690	male	CP2	PassengerArea	561782	male
C_USB1_f	Passenger_Area	561566	female	CP2	PassengerArea	561781	female
C_USB1_f	Passenger_Area	561690	male	CP3	PassengerArea	561782	male
C_USB1_s	Passenger_Area	561566	female	CP3	PassengerArea	561781	female
C_USB1_s	Passenger_Area	561690	male	CP4	PassengerArea	561782	male
C_USB2	Passenger_Area	563025	male	CP4	PassengerArea	561781	female
C_USB_1	Passenger_Area	563025	male	CP_LH	RrSeat	563601	male
C_USB_F.	Passenger_Area	561566	female	CP_LH	RrSeat	563600	female
C_USB_F.	Passenger_Area	561690	male	CP_RH	RrSeat	563601	male
C_USB_LH	RrSeat	561690	male	CP_RH	RrSeat	563600	female
C_USB_LH	RrSeat	561566	female	CPUP2	Dash	560898	male
C_USB_R.	Passenger_Area	561566	female	CPUP2	Dash	560900	female
C_USB_R.	Passenger_Area	561690	male	CPUP3	Dash	560898	male
C_USBF_f	Passenger_Area	561566	female	CPUP3	Dash	560900	female
C_USBF_f	Passenger_Area	561690	male	CPUP5	Dash	560898	male
C_USBR_f	Passenger_Area	561566	female	CPUP5	Dash	560900	female
C_USBR_f	Passenger_Area	561690	male	CRadio	P.RackLH	565922	male
CB_PR	P.RackLH	564238	male	CSw34	FrontRH	563815	male
CB_RS	RJBBreakersPanel	564238	male	CSw34	FrontRH	563832	female
CCust	RJB	562477	male	CSX1	EngineCmpt.	563135	male
CCust	RJB	562479	female	CSX1	EngineCmpt.	563134	female
CF_RS	Rear_Seat	564238	male	CSX3	EngineCmpt.	563135	male
CIND-1.A	ParcelRack	560908	female	CSX3	EngineCmpt.	563134	female
CIND-1.B	ParcelRack	560908	female	CT	FrontAxle	563869	female
CIND-2.A	ParcelRack	560908	female	CT_Fr	FrontAxle	560167	male
CIND-2.B	ParcelRack	560908	female	CT_Fr	FrontAxle	560159	female



# CONNECTORS LIST

No	Location	Part #	Gender	No	Location	Part #	Gender
CT_Rr	RJB	560167	male	L38	Parcel_Rack	560898	male
CT_Rr	RJB	560159	female	L39	Parcel_Rack	560898	male
CVIP	Dash	568085	male	L40	Parcel_Rack	560898	male
CXC1	Service_Cmpt	562477	male	L41	Parcel_Rack	560898	male
CXC1	Service_Cmpt	562479	female	L42	Parcel_Rack	560898	male
EIA	EngineCmpt.	563739	male	L43	Parcel_Rack	560898	male
L.21	FrontRoof	560605	female	L44	Parcel_Rack	560898	male
L.22	FrontRoof	560605	female	L45	Parcel_Rack	560898	male
L.23	FrontRoof	560605	female	L46	Parcel_Rack	560898	male
L.24	FrontRoof	560605	female	L47	Parcel_Rack	560898	male
L.25	FrontRoof	560605	female	L48	Parcel_Rack	560898	male
L.26	FrontRoof	560605	female	L49	Parcel_Rack	560898	male
L.27	FrontRoof	560605	female	L50	Parcel_Rack	560898	male
L.84	FrontRoof	560605	female	L51	Parcel_Rack	560898	male
L.85	FrontRoof	560605	female	L52	Passenger_Area	560898	male
L.86	FrontRoof	560605	female	L52	Passenger_Area	560900	female
L.87	FrontRoof	560605	female	L53	Passenger_Area	560898	male
L.88	FrontRoof	560605	female	L53	Passenger_Area	560900	female
L.89	FrontRoof	560605	female	L54	Passenger_Area	560898	male
L.90	FrontRoof	560605	female	L54	Passenger_Area	560900	female
L15	Front_Roof	561247	male	L55	Passenger_Area	560898	male
L16.A	FrontRoof	562615	female	L55	Passenger_Area	560900	female
L16.B	FrontRoof	562615	female	L56	Passenger_Area	560898	male
L17.A	Frontroof	562615	female	L56	Passenger_Area	560900	female
L17.B	FrontRoof	562615	female	L57	Passenger_Area	560898	male
L18.A	FrontRoof	562615	female	L57	Passenger_Area	560900	female
L18.B	FrontRoof	562615	female	L58	Passenger_Area	560898	male
L19	StepCmpt	562549	male	L58	Passenger_Area	560900	female
L20	StepCmpt	562549	male	L59A	OutsideFrontRH	563866	male
L20A	StepCmpt	562486	female	L59B	OutsideFrontRH	563865	female
L28	Parcel_Rack	560898	male	L60A	OutsideFrontLH	563866	male
L29	Parcel_Rack	560898	male	L60B	OutsideFrontLH	563865	female
L30	Parcel_Rack	560898	male	L61	OutsideFrontRH	562601	male
L30A.A	ParcelRack	560898	male	L62	OutsideFrontLH	562601	male
L30AA.A	ParcelRack	560898	male	L63	OutsideFrontRH	562155	male
L30BB.A	ParcelRack	560898	male	L64	OutsideFrontRH	562155	male
L31	Parcel_Rack	560898	male	L65	OutsideFrontLH	562155	male
L32	Parcel_Rack	560898	male	L66	OutsideFrontLH	562155	male
L33	Parcel_Rack	560898	male	L67	OutsideCenterRH	562155	male
L34	Parcel_Rack	560898	male	L68	OutsideCenterRH	562155	male
L35	Parcel_Rack	560898	male	L69	OutsideCenterLH	562155	male
L36	Parcel_Rack	560898	male	L70	OutsideCenterLH	562155	male
L37	Parcel_Rack	560898	male	L71A	RearVehicle	562601	male

# CONNECTORS LIST

No	Location	Part #	Gender	No	Location	Part #	Gender
L72	RrSideLH	562155	male	L184	ServiceCmpt	561247	male
L73A	RearVehicle	562601	male	L185.A	Service_Cmpt	562651	female
L74	RrSideRH	562155	male	L185.B	Service_Cmpt	562290	female
L75	RrSideLH	562155	male	L186.A	Dash	562651	female
L76	RrSideRH	562155	male	L186.B	Dash	562290	female
L77A	RearVehicle	562601	male	L187	Engine_Cmpt	561690	male
L78A	RearVehicle	562601	male	L188	Service_Cmpt	562486	female
L79A	RearVehicle	562601	male	L189	UpperFront	564513	female
L80A	RearVehicle	562601	male	L190	Dash	564513	female
L81.A	RearVehicle	562835	female	L199	EngineCmpt	562848	male
L81.B	RearVehicle	562834	male	L203	RH_Console	561690	male
L82A	RearVehicle	562348	female	L204	Parcel_Rack_RH	562803	male
L83A	RearVehicle	562348	female	L205	EngineCmpt	562485	male
L91A	RearVehicle	562601	male	L206	Parcel_Rack_RH	562803	male
L92A	RearVehicle	562601	male	L207.A	3rdLuggCmpt	561699	female
L130.A	RrAxleCmpt	561690	male	L207.B	3rdLuggCmpt	561701	female
L130.B	RrAxleCmpt	561690	male	L207.C	3rdLuggCmpt	561701	female
L131	RrAxleCmpt	561690	male	L207.D	3rdLuggCmpt	561699	female
L145	Parcelrack	562756	male	L207.E	3rdLuggCmpt	561701	female
L146	ParcelRackLH	562756	male	L207.F	3rdLuggCmpt	561699	female
L147	ParcelRackLH	562756	male	L207.G	3rdLuggCmpt	561699	female
L148	ParcelRackLH	562756	male	L207.H	3rdLuggCmpt	560926	female
L149	ParcelRackLH	562756	male	L207.I	3rdLuggCmpt	560926	female
L150	ParcelRackLH	562756	male	L212	ParcelRackLH	563589	male
L151	ParcelRackLH	562756	male	L213	ParcelRackLH	563589	male
L152	ParcelRackLH	562756	male	L214	ParcelRackLH	563589	male
L153	ParcelRackLH	562756	male	L243	ParcelRackRH	562756	male
L154	ParcelRackLH	562756	male	L244	ParcelRackRH	562756	male
L155	ParcelRackLH	562756	male	L245	ParcelRackRH	562756	male
L156	ParcelRackLH	562756	male	L246	ParcelRackRH	562756	male
L157	ParcelRackLH	562756	male	L247	ParcelRackRH	562756	male
L158	ParcelRackLH	562756	male	L248	ParcelRackRH	562756	male
L173	EngineCmpt	563590	female	L249	ParcelRackRH	562756	male
L174A	EngineCmpt	563590	female	L250	ParcelRackRH	562756	male
L175	CondCmpt	563590	female	L251	ParcelRackRH	562756	male
L176	3rd_Lugg_Cmpt	561247	male	L252	ParcelRackRh	562756	male
L177	3rd_Lugg_Cmpt	561247	male	L253	ParcelRackRH	562756	male
L177A	WCL_Lugg_Door	561690	male	L254	ParcelRackRH	562756	male
L177B	WCL_Lugg_Door	561690	male	L255	ParcelRackRH	562756	male
L180	2nd_Lugg_Cmpt	561247	male	L256	ParcelRackRH	562756	male
L181	2nd_Lugg_Cmpt	561247	male	L280	Driver_Area	561690	male
L182	1st_Lugg_Cmpt	561247	male	L282	3rd_LH_Lugg_Cmpt	561690	male
L183	1st_Lugg_Cmpt	561247	male	L283	Service_Cmpt	562485	male

# CONNECTORS LIST

No	Location	Part #	Gender	No	Location	Part #	Gender
L285.A	Rear_Vehicle	562835	female	R14	WCLCmpt	564496	male
L285.B	Rear_Vehicle	562834	male	R15	RJB	563616	female
L286.A	Rear_Vehicle	562835	female	R16	RJB	563616	female
L286.B	Rear_Vehicle	562834	male	R21	FJB	560525	male
L298A	EngineCmpt	563590	female	R23A	FJB	564496	male
L301	Dash	560898	male	R26	Evap_Cmpt	564496	male
L303	EngineCmpt	563590	female	R27	RHConsole	564496	male
L304	EngineCmpt	563590	female	R28	RrSeat	563409	male
L305.H	Enginecmpt	563764	female	R29	RJB	563409	male
L305.P	Enginecmpt	562477	male	R30	FJB	564496	male
L306	RJBCmpt	561247	male	R31	FJB	564496	male
L310	FrInterRoof	560898	male	R34	RJB	564210	male
L310A	FrInterRoof	561552	female	R36	FJB	564496	male
L350.A	RrAxleCmpt	564552	male	R37	FJB	564496	male
L350.B	RrAxleCmpt	563340	male	R44	P.RackFrLH	564496	male
L350.C	RrAxleCmpt	562251	male	R45	P.RackFrLH	564496	male
L391	Parcel_Rack	560898	male	R47	WCLCmpt	564496	male
Mo3	Dash	561667	female	R50	FJB	564496	male
Mo4	Dash	564161	male	R51	P.RackFrLH	564496	male
Mo7	CondCmpt	561890	male	R52	P.RackFrLH	564496	male
Mo8	CondCmpt	561890	male	R55	FJB	564496	male
Mo10	P.RackLH	561515	male	R57	RJB	564496	male
Mo11	P.RackRH	561515	male	R65	P.RackFrLH	564496	male
Mo12	EvapCmpt	561690	male	R66	P.RackFrLH	564496	male
Mo17	Service_Cmpt	563626	male	R210	Parcel_Rack_LH	560525	male
Mo19	Service_Cmp	562474	male	Res2	Parcel_Rack_JB	563205	male
Mo20	Service_Cmpt	562474	male	Res3.A	ParcelRack	563590	female
Mo22	RH_Console	561186	male	Res4	RH_Console	563590	female
Mo27	CondCmpt	561890	male	Res6	RJB	563590	female
Mo28	CondCmpt	561890	male	Res7	Dash	563590	female
Mo29	RJB	563590	female	Res14	Evap_Cmpt	563205	male
Mo37	ServiceCmpt	562477	male	Res20	Parcel_Rack	563590	female
Mo38	WCLUperDoor	564161	male	Res31	UreaCmpt	562350	male
Mo65	EngineCmpt	568089	male	Res32	UreaCmpt	563764	female
Mo67	EngineCmpt	568089	male	Res37.A	Front_Clearance	561690	male
Mo68	EngineCmpt	568089	male	Res37.B	Front_Clearance	561690	male
Mo69	EngineCmpt	568089	male	Res46	RrAxleCmpt	563590	female
Mo70	EngineCmpt	568089	male	Res53	Dash	563590	female
Mo71	EngineCmpt	568089	male	RT34.1	FJB	561904	female
Mo72	EngineCmpt	568089	male	RT34.2	FJB	561904	female
Mo73	EngineCmpt	568089	male	RT34.3	FJB	561904	female
R1	R1	562486	female	Se2	LH_Console	561566	female
R3	RJB	563409	male	Se11.A	Cond_Cmpt	564460	female
R12	Evap_Cmpt	563409	male	Se11.B	Cond_Cmpt	564460	female
R13	WCLCmpt	564496	male	Se11.C	Cond_Cmpt	564460	female

# CONNECTORS LIST

No	Location	Part #	Gender	No	Location	Part #	Gender
Se13	Engine_Cmpt	562350	male	Se78	PneuPlate	563159	female
Se14.A	Driver_Area	561782	male	Se79	Front_Axle	563340	male
Se14.B	Driver_Area	561781	female	Se83	FrontAxle	642190	female
Se18	PneuPlate	561566	female	Se84	FrontAxle	642190	female
Se19_P	Service_Cmpt	563677	male	Se85	RearAxle	642190	female
Se19_S	ServiceCmpt	563677	male	Se86	RearAxle	642190	female
Se20	Head_Lamp_RH	562426	male	Se87	RearAxle	642190	female
Se21	Dash	561248	female	Se88	RearAxle	642190	female
Se22	CondCmpt	562877	female	Se89	EngineCmpt	562350	male
Se23	Engine_Cmpt	563159	male	Se94	WCLUpperdoor	562877	female
Se24	EvapCmpt	563758	female	Se100	WCLUpperdoor	562479	female
Se25	Passenger_Area	561248	female	shell1	RJB	561932	male
Se29	Engine_Cmpt	561566	female	shell1_1	Luggage_Cmpt	561690	male
Se30	EngineCmpt	562877	female	So4	RH_Console	641385	male
Se31	EngineCmpt	562877	female	So5	RH_Console	641385	male
Se32	Rear_Axle_Cmpt	562426	male	So6	RH_Console	641385	male
Se33	Rear_Axle_Cmpt	562856	male	So7	Service_Cmpt	561566	female
Se34	Rear_Axle_Cmpt	562426	male	So8	ServiceCmpt	641385	male
Se35	Rear_Axle_Cmpt	562426	male	So9	EngineCmpt	560016	female
Se36	Rear_Axle_Cmpt	562427	male	So10	CondCmpt	562485	male
Se37	Front_Axle_LH	641132	female	So11	Cond_Cmpt	561566	female
Se38	Front_Axle_RH	641132	female	So13	Evap_Cmpt	563204	female
Se39	Rear_Axle_LH	641132	female	So15	PneuPlate	641385	male
Se40	Rear_Axle_LH	641132	female	So16	PneuPlate	641385	male
Se45.A	ServiceCmpt	563409	male	So17	PneuPlate	562848	male
Se49	Engine_Cmpt	561690	male	So20	PneuPlate	641385	male
Se50.A	FJB	561904	female	So21	Front_Axle_Cmpt	564046	female
Se50.B	FJB	561904	female	So22	Front_Axle_Cmpt	564046	female
Se51	FJB	563589	male	So23	Rear_Axle_Cmpt	564046	female
Se53	Service_Cmpt	563159	female	So24	Rear_Axle_Cmpt	564046	female
Se54	Service_Cmpt	563159	female	So27	RearAxleCmpt	564045	female
Se55	Service_Cmpt	563159	female	So29	WCLCmpt	641385	male
Se56	WCLCmpt.	562479	female	So50	RearAxleCmpt	564046	female
Se57	Pneumatic Panel	563159	female	So52	FrontAxleCmpt	564045	female
Se62	WCLLuggDoor	561690	male	So53	Rear_Axle_Cmpt	641385	male
Se63	EngineCmpt	641132	female	So55	PneuPlate	562848	male
Se64	EngineCmpt	641132	female	So70	PneumaticPanel	641385	male
Se65	Dash	564042	female	spBar2	Engine_Cmpt	564135	male
Se66	FrontAxle	564039	female	spBar3	Parcel_Rack_LH	564135	male
Se67	FJB	563159	female	spBar4	EngineCmpt	564135	male
Se69	FJB	563159	female	spBar5	EngineCmpt	564135	male
Se76	EntranceDoor	562479	female	spBar6	EngineCmpt	564135	male
Se77	FrontVehicle	563159	female	spBar7	UreaCmpt	564135	male

# CONNECTORS LIST

No	Location	Part #	Gender	No	Location	Part #	Gender
spBar11	RearVehicle	564135	male	Spk23.A	FroutsideLH	563994	male
spBar12	RearVehicle	564135	male	Spk23.B	FroutsideRH	563996	female
spBar13	EngineCmpt	564135	male	Spk24	Froutsidecenter	563994	male
spBar14	EngineCmpt	564135	male	Spk25	Froutsidecenter	563994	male
spBar15	EngineCmpt	564135	male	Sw2	Dash	562763	male
spBar16	EngineCmpt	564135	male	Sw4	Dash	562763	male
spBar19	CondensorCmpt	564135	male	Sw10A	LH_Console	562763	male
spBar20	CondensorCmpt	564135	male	Sw12	Dash	562763	male
spBar21	CondensorCmpt	564135	male	Sw13	Dash	562763	male
spBar22	EngineCmpt	564135	male	Sw14	Dash	562763	male
spBar23	EngineCmpt	564135	male	Sw16	RJB	563135	male
spBar24	FJB	564135	male	Sw16	Dash	562763	male
spBar25	EngineCmpt	564135	male	Sw17	Dash	562763	male
spBar26	FrAxleCmpt	564135	male	Sw20	Dash	562763	male
spBar27	FrAxleCmpt	564135	male	Sw24	Dash	562763	male
Spk1_L	Parcel_Rack_LH	563994	male	Sw25	Dash	562763	male
Spk1_R	Parcel_Rack_RH	563994	male	Sw29	Dash	562763	male
Spk2_L	Parcel_Rack_LH	563994	male	Sw30	LHConsol	562763	male
Spk2_R	Parcel_Rack_RH	563994	male	Sw34	FrEntranceDoor	563832	female
Spk3_L	Parcel_Rack_LH	563994	male	Sw38	LH_Console	562763	male
Spk3_R	Parcel_Rack_RH	563994	male	Sw41	LH_Console	562749	male
Spk4_L	Parcel_Rack_LH	563994	male	Sw42	WCL_Cmpt	561635	female
Spk4_R	Parcel_Rack_RH	563994	male	Sw44.A	FJB	562403	female
Spk5_L	Parcel_Rack_LH	563994	male	Sw45.A	3rd_Lugg_Cmpt	562403	female
Spk5_R	Parcel_Rack_RH	563994	male	Sw46.A	3rd_Lugg_Cmpt	562403	female
Spk6_L	Parcel_Rack_LH	563994	male	Sw46B.A	3rdLuggCmpt.	562403	female
Spk6_R	Parcel_Rack_RH	563994	male	Sw46B.B	3rdLugg.Cmpt.	562403	female
Spk7_L	Parcel_Rack_LH	563994	male	Sw49.A	2nd_Lugg_Cmpt	562403	female
Spk7_R	Parcel_Rack_RH	563994	male	Sw50.A	2nd_Lugg_Cmpt	562403	female
Spk8_L	Parcel_Rack_LH	563994	male	Sw51.A	1st_Lugg_Cmpt	562403	female
Spk8_R	Parcel_Rack_RH	563994	male	Sw52.A	1st_Lugg_Cmpt	562403	female
Spk9_L	Parcel_Rack_LH	563994	male	Sw58	EngineCmpt.	563135	male
Spk9_R	Parcel_Rack_RH	563994	male	Sw59	EngineCmpt.	563135	male
Spk10_L	Parcel_Rack_LH	563994	male	Sw64.A	Service_Cmpt	560815	female
Spk10_R	Parcel_Rack_RH	563994	male	Sw64.B	Service_Cmpt	560815	female
Spk11_L	Parcel_Rack_LH	563994	male	Sw70	Dash	562763	male
Spk11_R	Parcel_Rack_RH	563994	male	Sw71	EngineCmpt	562348	female
Spk12_L	Parcel_Rack_LH	563994	male	Sw80A	EngineCmpt	562763	male
Spk12_R	Parcel_Rack_RH	563994	male	Sw81.A	Dash	562905	male
Spk13_L	Parcel_Rack_LH	563994	male	Sw81.B	Dash	562905	male
Spk13_R	Parcel_Rack_RH	563994	male	Sw82A	RJB	563618	male
Spk14_L	Parcel_Rack_LH	563994	male	Sw83A	Dash	562581	male
Spk14_R	Parcel_Rack_RH	563994	male	Sw84	EngineCmpt.	563135	male
Spk22	Dash	563994	male	Sw85	LH_Console	562749	male

# CONNECTORS LIST

No	Location	Part #	Gender	No	Location	Part #	Gender
Sw95.A	WCLDoor	561626	female	Tab70b.A	ParcelRack	561626	N/A
Sw95.B	WCLDoor	561626	female	TermL152B	ParcelRackLH	562505	N/A
Sw96.A	WCL_Door	562615	female	TermL249B	ParcelRackRH	562505	N/A
Sw96.B	WCL_Door	562615	female	USB.MOD	1stseat	561690	male
Sw96.C	WCLDoor	562615	female	USB.MOD	1stseat	561566	female
Sw97.A	WCLSystem	562615	female	USB.WCL.F	PassengerArea	561690	male
Sw97.B	WCLSystem	562615	female	USB.WCL.F	PassengerArea	561566	female
Sw97.C	WCLSystem	562615	female	USB.WCL.F	PassengerArea	561690	male
Sw98.A	WCLSystem	561626	female	USB.WCL.F	PassengerArea	561566	female
Sw98.B	WCLSystem	561626	female	USB1L	PassengerArea	563025	male
Sw103	LH_Console	562763	male	USB1R	PassengerArea	563025	male
Sw105	Dash	563590	female	USB2	Passenger_Area	563025	male
Sw116.A	Luggages	560079	female	USB2L	Passenger_Area	561690	male
Sw116.B	Luggages	560079	female	USB2R	Passenger_Area	561690	male
Sw122	Dash	562763	male	USB3L	Passenger_Area	561690	male
Sw123	Dash	562763	male	USB3R	Passenger_Area	561690	male
Sw137	Dash	562763	male	USB4L	Passenger_Area	561690	male
Sw138	FJB	561690	male	USB4R	Passenger_Area	561690	male
Sw139	FJB	561690	male	USB5L	Passenger_Area	561690	male
Sw140	FJB	561566	female	USB5R	Passenger_Area	561690	male
Sw141	FJB	561690	male	USB6L	Passenger_Area	561690	male
Sw142	LHConsole	562763	male	USB6R	Passenger_Area	561690	male
Sw143	Driver_Area	562485	male	USB7L	Passenger_Area	561690	male
Sw144	FJB	561690	male	USB7R	Passenger_Area	561690	male
Sw152	Driver_Area	562471	male	USB8L	Passenger_Area	563025	male
Sw152.	Driver_Area	562471	male	USB9L	Passenger_Area	563025	male
Sw161	Dash	562763	male	USB9R	Passenger_Area	563025	male
sym691_1	Parcel_Rack_LH	562464	male	USB10L	Passenger_Area	561690	male
sym762_1	FrInterRoof	561611	male	USB10R	Passenger_Area	561690	male
sym762_1	FrInterRoof	561610	female	USB11L	Passenger_Area	561690	male
sym780_1	FrInterRoof	563040	female	USB11R	Passenger_Area	561690	male
sym781_1	FrInterRoof	563071	male	USB12L	Passenger_Area	561690	male
sym797_2	ParcelRack	565180	female	USB12R	Passenger_Area	561690	male
sym803_2	ParcelRack	565180	female	USB13L	Passenger_Area	561690	male
sym814_2	ParcelRack	565180	female	USB13R	Passenger_Area	561690	male
sym815_2	ParcelRack	565180	female	USB14L	Passenger_Area	561690	male
sym816_2	ParcelRack	565180	female	USB14R	Passenger_Area	561690	male
sym824_2	ParcelRack	565180	female	USB_Mod	Passenger_Area	561690	male
sym826_2	ParcelRack	565180	female	USB_Mod	Passenger_Area	561566	female
Tab1.A	ParcelRack	561626	N/A	USB_WCL	Passenger_Area	563025	male
tab69.A	ParcelRack	565180	N/A	VECF1	FJB	563186	male
tab70.A	ParcelRack	565180	N/A	VECF2	FJB	563183	male
Tab70a.A	ParcelRack	561626	N/A	VECF3	FJB	563185	male



# CONNECTORS LIST

No	Location	Part #	Gender	No	Location	Part #	Gender
A1	RJB	563975	male	A78	RJB	562583	female
A2	FJB	563984	male	A79	RJB	562583	female
A3.A	dash	565910	male	A80	EngineCmpt.	562479	female
A3.B	Dash	565908	male	A81CN1	FJB	562767	male
A3.C	Dash	565909	male	A81CN3A	FJB	564741	male
A5	Service_Cmpt	562428	female	A81CN3B	FJB	564742	male
A6	Engine_Cmpt	562427	male	A83	FJB	565970	female
A7	Rear_Axle_Cmpt	563979	male	A96	FJB	564205	male
A9.Cx1	FJB	564041	female				
A9.Cx2	FJB	563678	male				
A9.Cx3	FJB	564037	male				
A9.Cx4	FJB	564038	female	A98	Upperfront	563953	male
A14A.A	Dash	562766	male	A99	FJB	564205	male
A14A.B	Dash	562767	male	A100	FrontAxle	563632	male
A14A.C	Dash	562765	male	A101	RearRH Axel	563632	male
A15	Dash	562464	male	A102	RearLH Axel	563632	male
A18.J1	FJB	562794	male	A103	Dash	562070	female
A18.J2	FJB	562650	male	A104	Dash	561606	female
A24.A	RH_Console	561890	male	A107	Parcel_rack_LH	565940	male
A24.B	RH_Console	561566	female	A108.P1	Parcel_Rack_LH	561247	male
A27	Service_Cmpt	562929	male	A108.P2	Parcel_Rack_LH	561550	male
A28	Service_Cmpt	562928	male	A110.A	InterFrRoof	562479	female
A34.7	Rad_Cmpt	564258	male	A111	Entrancedoor	561690	male
A34.J	Rad_Cmpt	568118	male	A112.X2	Parcel_Rack	bidon	male
A34.K	Rad_Cmpt	564270	male	A112.X5	Parcel_Rack	bidon	male
A34.L	Rad_Cmpt	564269	male	A112.X6	Parcel_Rack	bidon	male
A36.JA	FJB	562767	male	A112.X7	Parcel_Rack	563918	male
A36.JB	FJB	562765	male	A112.X8	Parcel_Rack	bidon	male
A36.JC	FJB	562957	male	A112.X9	Parcel_Rack	bidon	male
A37.JA	FJB	562767	male	A112.X10	Parcel_Rack	bidon	male
A37.JB	FJB	562765	male	A113.X1	Parcel_Rack	563916	male
A37.JC	FJB	562957	male	A113.X2	Parcel_Rack	bidon	male
A69L.A	P.RackLH	563025	male	A113.X3	P.RackLH	563920	male
A69L.B2	P.RackLH	bidon	male	A113.X4	P.RackLH	bidon	male
A69L.B4	P.RackLH	bidon	male	A130.	Driver_Area	563226	male
A69L.C	P.RackLH	bidon	male	A130.J1	3rd_LH_Lugg_Cmpt	563226	male
A69R.A	P.RackLH	563025	male	A130.J2	3rd_LH_Lugg_Cmpt	563227	male
A69R.B1	P.RackLH	bidon	male	A130.J4	3rd_LH_Lugg_Cmpt	563879	male
A69R.B2	P.RackLH	bidon	male	A131.A	Engine_Cmpt	561782	male
A69R.B3	P.RackLH	bidon	male	A131.B	Engine_Cmpt	561781	female
A69R.B4	P.RackLH	bidon	male	A132.A	Driver_Area	563967	male
A69R.C	P.RackLH	bidon	male	A132.B	Driver_Area	561551	female
A77	RJB	564547	male	A134.A	Engine_Cmpt	561782	male



# CONNECTORS LIST

No	Location	Part #	Gender	No	Location	Part #	Gender
A134.B	Engine_Cmpt	561781	female	AE51.J2	RJB	564037	female
A135.A	Engine_Cmpt	561782	male	AE51.J3	RJB	565957	male
A135.B	Engine_Cmpt	561781	female	AE52.J1	RJB	563679	male
A136.A	Engine_Cmpt	561782	male	AE52.J2	RJB	564037	female
A136.B	Engine_Cmpt	561781	female	AE52.J3	RJB	565957	male
A138	CondensorCmpt.	563787	male	AE53.J1	RJB	563679	male
A139.A	3rd_LH_Lugg_Cmpt	561782	male	AE53.J2	RJB	564037	female
A139.B	3rd_LH_Lugg_Cmpt	561781	female	AE53.J3	RJB	565957	male
A139.C	3rd_LH_Lugg_Cmpt	565158	female	AE54.J1	EvaporatorCmpt.	563679	male
A140	Driver_Area	563226	male	AE54.J2	EvaporatorCmpt.	564037	female
A160.A	LuggCmpt	562477	male	AE54.J3	CondensorCmpt.	565957	male
A160.B	LuggCmpt	562884	female	AE55.J1	Dash	563679	male
AE41.J1	FJB	563679	male	AE55.J2	Dash	564037	female
AE41.J2	FJB	564037	female	AE55.J3	Dash	564004	male
AE41.J3	FJB	564004	male	AE56.J1	Dash	563679	male
AE42.J1	FJB	563679	male	AE56.J2	Dash	564037	male
AE42.J2	FJB	564037	female	AE56.J3	Dash	564004	male
AE42.J3	FJB	564004	male	AE57.J1	WCLCmpt.	563679	male
AE43.J1	FJB	563679	male	AE57.J2	WCLCmpt.	564037	male
AE43.J2	FJB	564037	male	AE57.J3	WCLCmpt.	564004	male
AE43.J3	FJB	565957	male	Alt_LR.A	EngineCmpt.	563746	female
AE44.J1	FJB	563679	male	Alt_LR.B	EngineCmpt.	560815	female
AE44.J2	FJB	564037	female	Alt_LR.C	EngineCmpt.	564469	female
AE44.J3	FJB	565957	male	Alt_UR.A	EngineCmpt.	563746	female
AE45.J1	FJB	563679	male	Alt_UR.B	EngineCmpt.	560815	female
AE45.J2	FJB	564037	female	Alt_UR.C	EngineCmpt.	564469	female
AE45.J3	FJB	565957	male	AltLL.A	EngineCmpt.	563746	female
AE46.J1	FJB	563679	male	AltLL.B	EngineCmpt.	560815	female
AE46.J2	FJB	564037	female	AltLL.C	EngineCmpt.	564469	female
AE46.J3	FJB	565957	male	B85	EngineCmpt	563815	male
AE47.J1	RHConsole	563679	male	B96	EngineCmpt	563821	male
AE47.J2	RHConsole	564037	female	B96B	EngineCmpt	563823	male
AE47.J3	RHConsole	565957	male	B97	EngineCmpt	563816	male
AE48.J1	RHConsole	563679	male	B98	EngineCmpt	563817	male
AE48.J2	RHConsole	564037	female	B99	EngineCmpt	563815	male
AE48.J3	RHConsole	565957	male	B115A	EngineCmpt.	564226	male
AE49.J1	RJB	563679	male	B142C	EngineCmpt.	563515	male
AE49.J2	RJB	564037	male	B310	EngineCmpt.	565967	male
AE49.J3	RJB	565957	male	C.243	ServiceCmpt.	562789	male
AE50.J1	RJB	563679	male	C.243	ServiceCmpt.	565131	female
AE50.J2	RJB	564037	male	C1	FJB	563589	male
AE50.J3	RJB	565957	male	C1	FJB	563590	female
AE51.J1	RJB	563679	male	C1A	FJB	561611	male

# CONNECTORS LIST

No	Location	Part #	Gender	No	Location	Part #	Gender
C1A	FJB	561610	female	C18	FJB	561986	male
C1B	Parcel_Rack_LH	561611	male	C18	FJB	561987	female
C1B	Parcel_Rack_LH	561610	female	C19	RJB	561986	male
C1S	FJB	563589	male	C19	RJB	561987	female
C1S	FJB	563590	female	C20A	AFSS	562485	male
C2	Service_Cmpt	563580	male	C20A	AFSS	562486	female
C2	Service_Cmpt	563581	female	C20B	Evap_Cmpt	562485	male
C2A	FJB	563580	male	C20B	Evap_Cmpt	562486	female
C2A	FJB	563581	female	C23	Evap.Cmpt.	564034	male
C2bb	FJB	564034	male	C23	Evap.Cmpt.	564035	female
C2bb	FJB	564035	female	C24_plug	Evap_Cmpt	561690	male
C3_plug	RJB	563589	male	C24_sock	Evap_Cmpt	561566	female
C3_socket	RJB	563590	female	C25	Parcel_Rack_LH	561550	male
C3S	RJB	563593	male	C25	Parcel_Rack_LH	561667	female
C3S	RJB	563590	female	C25.	Parcel_Rack_LH	561669	male
C4	FJB	563580	male	C25.	Parcel_Rack_LH	561670	female
C4	FJB	563581	female	C25A	ParcalrackLH	561515	male
C5	FJB	563589	male	C25A	ParcelRackLH	561552	female
C5	FJB	563590	female	C25A.	ParcalrackLH	561669	male
C5S	FJB	563589	male	C25A.	ParcalrackLH	561670	female
C5S	FJB	563590	female	C26	UreaCmpt.	563226	male
C6	FJB	563582	male	C26	UreaCmpt.	563613	female
C6	FJB	563583	female	C26A	UreaCmpt.	568110	male
C9	RJB	561986	male	C26A	UreaCmpt.	568109	female
C9	RJB	561987	female	C26B	UreaCmpt.	563227	male
C10	Engine_Cmpt	562477	male	C26B	UreaCmpt.	563614	female
C10	Engine_Cmpt	562479	female	C29	3rd_Lugg_Cmpt	563651	male
C11	Service_Cmpt	563580	male	C29	3rd_Lugg_Cmpt	563652	female
C11	Service_Cmpt	563581	female	C30	3rd_Lugg_Cmpt	561710	male
C12	Engine_Cmpt	562581	male	C30	3rd_Lugg_Cmpt	561709	female
C12	Engine_Cmpt	562583	female	C31W	3rdLuggCmpt.	563227	male
C13_plug	RH_Console	563589	male	C31W	3rdLuggCmpt.	563614	female
C13_socket	RH_Console	563590	female	C32W	WCLCmpt.	561640	male
C13S	RH_Console	563589	male	C32W	WCLCmpt.	561639	female
C13S	RH_Console	563590	female	C33	WCLCmpt.	564034	male
C14	RJB	561986	male	C33	WCLCmpt.	564035	female
C14	RJB	561987	female	C33W	WCLCmpt.	562477	male
C15A	EvapCmpt	568110	male	C33W	WCLCmpt.	562479	female
C15A	EvapCmpt	568109	female	C34	RH_Console	561986	male
C16	RJB	561577	male	C34	RH_Console	561987	female
C16	RJB	561605	female	C35	WCLdoor	562485	male
C17	RJB	560195	male	C35	WCLdoor	562486	female
C17	RJB	560169	female	C36	FJB	561986	male

# CONNECTORS LIST

No	Location	Part #	Gender	No	Location	Part #	Gender
C36	FJB	561987	female	C62	Fr_Service_Door	562566	male
C37	Parcel_Rack_LH	562557	male	C62	Fr_Service_Door	562565	female
C37	Parcel_Rack_LH	562558	female	C64	EngineCmpt.	568110	male
C37.	Parcel_Rack_LH	561734	male	C64	EngineCmpt.	568109	female
C37.	Parcel_Rack_LH	561735	female	C68	P.RackLH	561646	male
C38	ParcelRackLH	562555	male	C68	P.RackLH	561644	female
C38	ParcelRackLH	562556	female	C70	FJB	561646	male
C38.	ParcelRackLH	561734	male	C70	FJB	561645	female
C38.	ParcelRackLH	561735	female	C70B	FJB	561710	male
C39A	Engine_Cmpt	561782	male	C70B	FJB	561989	female
C39A	Engine_Cmpt	561781	female	C71	FJB	561646	male
C40	Dash	562485	male	C71	FJB	561645	female
C40	Dash	562486	female	C72	FJB	561646	male
C44_plug	FJB	561577	male	C72	FJB	561645	female
C44_socket	FJB	561605	female	C74	FJB	561710	male
C45	FJB	561643	male	C74	FJB	561989	female
C45	FJB	561642	female	C77	FJB	562350	male
C46	WCLCmpt.	564228	male	C77	FJB	563764	female
C46	WCLCmpt.	564229	female	C79	RJB	561986	male
C50	RJB	563931	male	C79	RJB	561987	female
C50	RJB	563930	female	C81_plug	1stLuggCmpt.	562477	male
C51	Engine_Cmpt	561932	male	C81_socket	1stLuggCmpt.	562479	female
C51	Engine_Cmpt	560933	female	C82	1stLuggCmpt.	562581	male
C52	Evap.Cmpt.	563618	male	C82	2ndLuggCmpt.	562583	female
C52	Evap.Cmpt.	563616	female	C83_plug	2ndLuggCmpt.	562477	male
C54	EngineCmpt.	563226	male	C83_socket	2ndLuggCmpt.	562479	female
C54	EngineCmpt.	563613	female	C84_plug	2ndLuggCmpt.	562477	male
C54A	EngineCmpt.	568110	male	C84_socket	2ndLuggCmpt	562479	female
C54A	EngineCmpt.	568109	female	C85_plug	3rdLuggCmpt.	562477	male
C54B	EngineCmpt.	563589	male	C85_socket	3rdLuggCmpt.	562479	female
C54B	EngineCmpt.	563590	female	C86	3rdLuggCmpt.	563618	male
C56	3rd_LH_Lugg_Cmpt	561643	male	C86	3rdLuggCmpt.	563616	female
C56	3rd_LH_Lugg_Cmpt	561642	female	C87	Engine_Cmpt	562485	male
C57	3rd_LH_Lugg_Cmpt	561782	male	C87	Engine_Cmpt	562486	female
C57	3rd_LH_Lugg_Cmpt	561781	female	C88	WCLCmpt.	563227	male
C57A	Engine_Cmpt	561690	male	C88	WCLCmpt.	563614	female
C57A	Engine_Cmpt	561566	female	C91	RJB	564619	male
C58	CondensorCmpt.	564567	male	C91	RJB	562282	female
C58	CondensorCmpt.	564568	female	C92A	EngineCmpt.	563226	male
C59	LuggCmpt.	561646	male	C92A	EngineCmpt.	563613	female
C59	LuggCmpt.	561645	female	C92B	EngineCmpt.	562581	male
C61	Fr_Service_Door	561669	male	C92B	EngineCmpt.	562583	female
C61	Fr_Service_Door	561670	female	C92C	EngineCmpt.	562581	male

# CONNECTORS LIST

No	Location	Part #	Gender	No	Location	Part #	Gender
C92C	EngineCmpt.	562583	female	C171	LH_Console	561646	male
C94_plug	FJB	563589	male	C171	LH_Console	561645	female
C94_socket	FJB	563590	female	C175	RJB	563226	male
C95	FJB	561646	male	C175	RJB	563613	female
C95	FJB	561645	female	C193_r	RJB	563589	male
C96	FJB	561643	male	C193_s	RJB	563590	female
C96	FJB	561642	female	C194	FJB	563589	male
C97	FJB	561643	male	C194	FJB	563590	female
C97	FJB	561642	female	C206	Parcel_Rack_RH	562503	male
C98	2nd_LH_Lugg_Cmpt	562581	male	C206	Parcel_Rack_RH	562507	female
C98	2nd_LH_Lugg_Cmpt	562583	female	C207	Parcel_Rack_LH	562503	male
C99	2nd_RH_Lugg_Cmpt	562581	male	C207	Parcel_Rack_LH	562507	female
C99	2nd_RH_Lugg_Cmpt	562583	female	C213	Parcel_Rack_LH	561515	male
C100	EvapCmpt.	562477	male	C213	Parcel_Rack_LH	561552	female
C100	EvapCmpt.	562479	female	C223	FJB	563227	male
C100S	EvapCmpt.	562477	male	C223	FJB	563614	female
C100S	EvapCmpt.	562479	female	C226	FJB	562650	male
C101	Service_Cmpt	561690	male	C226	FJB	562649	female
C101	Service_Cmpt	561566	female	C227	FJB	562650	male
C102A	CondensorCmpt.	563226	male	C227	FJB	562649	female
C102A	CondensorCmpt.	563613	female	C229	Dash	561782	male
C104S_plug	LuggCmpt.	563589	male	C229	Dash	561781	female
C104S_socket	LuggCmpt.	563590	female	C230	FrontInterRoof	562477	male
C110	PneumaticPanel	568110	male	C230	FrontInterRoof	562479	female
C110	PneumaticPanel	568109	female	C231	FJB	563409	male
C115	FrInterRoof	561690	male	C231	FJB	563410	female
C115	FrInterRoof	561566	female	C242	Service_Cmpt	562789	male
C116	FrInterRoof	561611	male	C242	Service_Cmpt	565131	female
C116	FrInterRoof	561610	female	C243	ServiceCmpt.	563347	male
C117	Parcel_Rack_LH	561690	male	C243	ServiceCmpt.	563180	female
C117	Parcel_Rack_LH	561566	female	C259	LuggCmpt	561637	male
C119	EngineDoor	568110	male	C259	LuggCmpt	561636	female
C119	EngineDoor	568109	female	C266	Parcelrack	561782	male
C121	EngineDoor	563347	male	C266	Parcelrack	561781	female
C121	EngineDoor	563180	female	C267	Parcelrack	561782	male
C122	EngineDoor	568118	male	C267	Parcelrack	561781	female
C122	EngineDoor	562531	female	C279	Service_Cmpt	562477	male
C144	ParcelRackJB	560852	male	C279	Service_Cmpt	562479	female
C144	ParcelRackJB	560851	female	C284	Parcel_Rack_LH	561247	male
C152	Cond_Cmpt	561611	male	C284	Parcel_Rack_LH	561248	female
C152	Cond_Cmpt	561610	female	C284_1	Parcel_Rack_LH	561247	male
C158	CondCmpt.	562477	male	C284_1	Parcel_Rack_LH	561248	female
C158	CondCmpt.	562479	female	C284_2	Parcel_Rack_LH	561247	male

# CONNECTORS LIST

No	Location	Part #	Gender	No	Location	Part #	Gender
C284_2	Parcel_Rack_LH	561248	female	C577A	Parcel_Rack	562006	male
C284_3	Parcel_Rack_LH	561247	male	C577A	Parcel_Rack	560908	female
C284_3	Parcel_Rack_LH	561248	female	C577AA	ParcelRack	562006	male
C284_4	Parcel_Rack_LH	561247	male	C577AA	ParcelRack	560908	female
C284_4	Parcel_Rack_LH	561248	female	C578	ParcelRackJB	562503	male
C284_5	Parcel_Rack_LH	561247	male	C578	ParcelRackJB	562507	female
C284_5	Parcel_Rack_LH	561248	female	C579	P.RackLH	562549	male
C349	Engine_Cmpt	565170	male	C579	P.RackLH	562550	female
C350	Engine_Cmpt	565170	male	C_ALT	EngineCmpt.	562581	male
C355	RJB	563582	male	C_ALT	EngineCmpt.	562583	female
C355	RJB	563583	female	C_ALT3	EngineCmpt.	562477	male
C356	ParcelRackJB	561710	male	C_ALT3	EngineCmpt.	562479	female
C356	ParcelRackJB	561709	female	C_BCIS_BHS	P.RackLH	561643	male
C357	P.RackJCB	564294	male	C_BCIS_BHS	P.RackLH	561641	female
C357	P.RackJCB	564295	female	C_BCIS_IFU	P.RackLH	562650	male
C358	P.RackLH	566033	male	C_BCIS_IFU	P.RackLH	562649	female
C358	P.RackLH	566034	female	C_BCIS_ODK	P.RackLH	562650	male
C380A	Dash	564222	male	C_BCIS_ODK	P.RackLH	562649	female
C380A	Dash	564224	female	C_BCIS_PWR	P.RackLH	561550	male
C397	RJB	562285	male	C_BCIS_PWR	P.RackLH	561667	female
C397	RJB	562282	female	C_BCIS_RDR	P.RackLH	565940	male
C463	EngineCmpt	568112	male	C_BCIS_SIG	P.RackLH	561690	male
C463	EngineCmpt	568111	female	C_BCIS_SIG	P.RackLH	561566	female
C464A	RJB	564222	male	C_BCIS_SW	P.RackLH	561637	male
C464A	RJB	564224	female	C_BCIS_SW	P.RackLH	561636	female
C465	Parcelrack	562581	male	C_BCIS_SW1	P.RackLH	561637	male
C465	Parcelrack	562583	female	C_BCIS_SW1	P.RackLH	561636	female
C466	LH_Consol	562503	male	C_Bike_Se	Front_Axle	562901	male
C466	LH_Consol	562507	female	C_Bike_Se	Front_Axle	562902	female
C574	P.RackRH	562549	male	C{EIF	Engine_Cmpt	563135	male
C574	P.RackRH	562550	female	C{EIF	Engine_Cmpt	563134	female
C575	ParcelRackRH	562503	male	C_Foot	FJB	563347	male
C575	ParcelRackRH	562507	female	C_Foot	FJB	563180	female
C576	Parcel_Rack_RH	561515	male	C_INV1	ParcelRack	562337	male
C576	Parcel_Rack_RH	561552	female	C_INV1	ParcelRack	562338	male
C576A	Parcel_Rack_RH	561515	male	C_INV2_1	ParcelRack	562337	male
C576A	Parcel_Rack_RH	561552	female	C_INV2_1	ParcelRack	562338	male
C576B	Parcel_Rack_RH	562006	male	C_INV2_2	ParcelRack	562337	male
C576B	Parcel_Rack_RH	560908	female	C_INV2_2	ParcelRack	562338	female
C576BB	ParcelRack	562006	male	C_INV3	ParcelRack	562337	male
C576BB	ParcelRack	560908	female	C_INV3	ParcelRack	562338	female
C577	Parcel_Rack	561515	male	C_JP_FBOX	Parcel_Rack_LH	561782	male
C577	Parcel_Rack	561552	female	C_JP_FBOX	Parcel_Rack_LH	561781	female

# CONNECTORS LIST

No	Location	Part #	Gender	No	Location	Part #	Gender
C_JP_Rad	Parcel_Rack_LH	561782	male	CIND1.A	ParcelRack	560908	female
C_JP_Rad	Parcel_Rack_LH	561781	female	CIND1.B	ParcelRack	560908	female
C_Mo9_p	Evap_Cmpt	561577	male	CIND_1.A	ParcelRack	560908	female
C_Mo9_s	Evap_Cmpt	561605	female	CIND_1.B	ParcelRack	560908	female
C_MVIEW	ParcelRackLH	563227	male	CINDWC-1.A	ParcelRack	560908	female
C_MVIEW	ParcelRackLH	563614	female	CINDWC-1.B	ParcelRack	560908	female
C_MVIEW	ParcelRackLH	39-01-214	male	CJUP1	Dash	560898	male
C_MVIEW	ParcelRackLH	39-01-214	female	CJUP1	Dash	560900	female
C_MVIEW	ParcelRackLH	562779	male	CJUP4	Dash	560898	male
C_MVIEW	ParcelRackLH	562465	male	CJUP4	Dash	560900	female
C_MVIEW	ParcelRackLH	562842	male	CJUR1	Dash	562485	male
C_USB1_f	Passenger_Area	561566	female	CJUR1	Dash	562486	female
C_USB1_f	Passenger_Area	561690	male	CJUR2	Dash	561577	male
C_USB1_l	Passenger_Area	561566	female	CJUR2	Dash	561605	female
C_USB1_l	Passenger_Area	561690	male	CL350	Cond_Cmpt	562251	male
C_USB1_m	Passenger_Area	563025	male	CP1	PassengerArea	561782	male
C_USB1_f	Passenger_Area	561566	female	CP1	PassengerArea	561781	female
C_USB1_f	Passenger_Area	561690	male	CP2	PassengerArea	561782	male
C_USB1_f	Passenger_Area	561566	female	CP2	PassengerArea	561781	female
C_USB1_f	Passenger_Area	561690	male	CP3	PassengerArea	561782	male
C_USB1_s	Passenger_Area	561566	female	CP3	PassengerArea	561781	female
C_USB1_s	Passenger_Area	561690	male	CP4	PassengerArea	561782	male
C_USB2	Passenger_Area	563025	male	CP4	PassengerArea	561781	female
C_USB_1	Passenger_Area	563025	male	CP_LH	RrSeat	563601	male
C_USB_F.	Passenger_Area	561566	female	CP_LH	RrSeat	563600	female
C_USB_F.	Passenger_Area	561690	male	CP_RH	RrSeat	563601	male
C_USB_LH	RrSeat	561690	male	CP_RH	RrSeat	563600	female
C_USB_LH	RrSeat	561566	female	CPUP2	Dash	560898	male
C_USB_R.	Passenger_Area	561566	female	CPUP2	Dash	560900	female
C_USB_R.	Passenger_Area	561690	male	CPUP3	Dash	560898	male
C_USBF_f	Passenger_Area	561566	female	CPUP3	Dash	560900	female
C_USBF_f	Passenger_Area	561690	male	CPUP5	Dash	560898	male
C_USBR_f	Passenger_Area	561566	female	CPUP5	Dash	560900	female
C_USBR_f	Passenger_Area	561690	male	CRadio	P.RackLH	565922	male
CB_PR	P.RackLH	564238	male	CSw34	FrontRH	563815	male
CB_RS	RJBBreakersPanel	564238	male	CSw34	FrontRH	563832	female
CCust	RJB	562477	male	CSX1	EngineCmpt.	563135	male
CCust	RJB	562479	female	CSX1	EngineCmpt.	563134	female
CF_RS	Rear_Seat	564238	male	CSX3	EngineCmpt.	563135	male
CIND-1.A	ParcelRack	560908	female	CSX3	EngineCmpt.	563134	female
CIND-1.B	ParcelRack	560908	female	CT	FrontAxle	563869	female
CIND-2.A	ParcelRack	560908	female	CT_Fr	FrontAxle	560167	male
CIND-2.B	ParcelRack	560908	female	CT_Fr	FrontAxle	560159	female

# CONNECTORS LIST

No	Location	Part #	Gender	No	Location	Part #	Gender
CT_Rr	RJB	560167	male	L38	Parcel_Rack	560898	male
CT_Rr	RJB	560159	female	L39	Parcel_Rack	560898	male
CVIP	Dash	568085	male	L40	Parcel_Rack	560898	male
CXC1	Service_Cmpt	562477	male	L41	Parcel_Rack	560898	male
CXC1	Service_Cmpt	562479	female	L42	Parcel_Rack	560898	male
EIA	EngineCmpt.	563739	male	L43	Parcel_Rack	560898	male
L.21	FrontRoof	560605	female	L44	Parcel_Rack	560898	male
L.22	FrontRoof	560605	female	L45	Parcel_Rack	560898	male
L.23	FrontRoof	560605	female	L46	Parcel_Rack	560898	male
L.24	FrontRoof	560605	female	L47	Parcel_Rack	560898	male
L.25	FrontRoof	560605	female	L48	Parcel_Rack	560898	male
L.26	FrontRoof	560605	female	L49	Parcel_Rack	560898	male
L.27	FrontRoof	560605	female	L50	Parcel_Rack	560898	male
L.84	FrontRoof	560605	female	L51	Parcel_Rack	560898	male
L.85	FrontRoof	560605	female	L52	Passenger_Area	560898	male
L.86	FrontRoof	560605	female	L52	Passenger_Area	560900	female
L.87	FrontRoof	560605	female	L53	Passenger_Area	560898	male
L.88	FrontRoof	560605	female	L53	Passenger_Area	560900	female
L.89	FrontRoof	560605	female	L54	Passenger_Area	560898	male
L.90	FrontRoof	560605	female	L54	Passenger_Area	560900	female
L15	Front_Roof	561247	male	L55	Passenger_Area	560898	male
L16.A	FrontRoof	562615	female	L55	Passenger_Area	560900	female
L16.B	FrontRoof	562615	female	L56	Passenger_Area	560898	male
L17.A	Frontroof	562615	female	L56	Passenger_Area	560900	female
L17.B	FrontRoof	562615	female	L57	Passenger_Area	560898	male
L18.A	FrontRoof	562615	female	L57	Passenger_Area	560900	female
L18.B	FrontRoof	562615	female	L58	Passenger_Area	560898	male
L19	StepCmpt	562549	male	L58	Passenger_Area	560900	female
L20	StepCmpt	562549	male	L59A	OutsideFrontRH	563866	male
L20A	StepCmpt	562486	female	L59B	OutsideFrontRH	563865	female
L28	Parcel_Rack	560898	male	L60A	OutsideFrontLH	563866	male
L29	Parcel_Rack	560898	male	L60B	OutsideFrontLH	563865	female
L30	Parcel_Rack	560898	male	L61	OutsideFrontRH	562601	male
L30A.A	ParcelRack	560898	male	L62	OutsideFrontLH	562601	male
L30AA.A	ParcelRack	560898	male	L63	OutsideFrontRH	562155	male
L30BB.A	ParcelRack	560898	male	L64	OutsideFrontRH	562155	male
L31	Parcel_Rack	560898	male	L65	OutsideFrontLH	562155	male
L32	Parcel_Rack	560898	male	L66	OutsideFrontLH	562155	male
L33	Parcel_Rack	560898	male	L67	OutsideCenterRH	562155	male
L34	Parcel_Rack	560898	male	L68	OutsideCenterRH	562155	male
L35	Parcel_Rack	560898	male	L69	OutsideCenterLH	562155	male
L36	Parcel_Rack	560898	male	L70	OutsideCenterLH	562155	male
L37	Parcel_Rack	560898	male	L71A	RearVehicle	562601	male

# CONNECTORS LIST

No	Location	Part #	Gender	No	Location	Part #	Gender
L72	RrSideLH	562155	male	L184	ServiceCmpt	561247	male
L73A	RearVehicle	562601	male	L185.A	Service_Cmpt	562651	female
L74	RrSideRH	562155	male	L185.B	Service_Cmpt	562290	female
L75	RrSideLH	562155	male	L186.A	Dash	562651	female
L76	RrSideRH	562155	male	L186.B	Dash	562290	female
L77A	RearVehicle	562601	male	L187	Engine_Cmpt	561690	male
L78A	RearVehicle	562601	male	L188	Service_Cmpt	562486	female
L79A	RearVehicle	562601	male	L189	UpperFront	564513	female
L80A	RearVehicle	562601	male	L190	Dash	564513	female
L81.A	RearVehicle	562835	female	L199	EngineCmpt	562848	male
L81.B	RearVehicle	562834	male	L203	RH_Console	561690	male
L82A	RearVehicle	562348	female	L204	Parcel_Rack_RH	562803	male
L83A	RearVehicle	562348	female	L205	EngineCmpt	562485	male
L91A	RearVehicle	562601	male	L206	Parcel_Rack_RH	562803	male
L92A	RearVehicle	562601	male	L207.A	3rdLuggCmpt	561699	female
L130.A	RrAxleCmpt	561690	male	L207.B	3rdLuggCmpt	561701	female
L130.B	RrAxleCmpt	561690	male	L207.C	3rdLuggCmpt	561701	female
L131	RrAxleCmpt	561690	male	L207.D	3rdLuggCmpt	561699	female
L145	Parcelrack	562756	male	L207.E	3rdLuggCmpt	561701	female
L146	ParcelRackLH	562756	male	L207.F	3rdLuggCmpt	561699	female
L147	ParcelRackLH	562756	male	L207.G	3rdLuggCmpt	561699	female
L148	ParcelRackLH	562756	male	L207.H	3rdLuggCmpt	560926	female
L149	ParcelRackLH	562756	male	L207.I	3rdLuggCmpt	560926	female
L150	ParcelRackLH	562756	male	L212	ParcelRackLH	563589	male
L151	ParcelRackLH	562756	male	L213	ParcelRackLH	563589	male
L152	ParcelRackLH	562756	male	L214	ParcelRackLH	563589	male
L153	ParcelRackLH	562756	male	L243	ParcelRackRH	562756	male
L154	ParcelRackLH	562756	male	L244	ParcelRackRH	562756	male
L155	ParcelRackLH	562756	male	L245	ParcelRackRH	562756	male
L156	ParcelRackLH	562756	male	L246	ParcelRackRH	562756	male
L157	ParcelRackLH	562756	male	L247	ParcelRackRH	562756	male
L158	ParcelRackLH	562756	male	L248	ParcelRackRH	562756	male
L173	EngineCmpt	563590	female	L249	ParcelRackRH	562756	male
L174A	EngineCmpt	563590	female	L250	ParcelRackRH	562756	male
L175	CondCmpt	563590	female	L251	ParcelRackRH	562756	male
L176	3rd_Lugg_Cmpt	561247	male	L252	ParcelRackRh	562756	male
L177	3rd_Lugg_Cmpt	561247	male	L253	ParcelRackRH	562756	male
L177A	WCL_Lugg_Door	561690	male	L254	ParcelRackRH	562756	male
L177B	WCL_Lugg_Door	561690	male	L255	ParcelRackRH	562756	male
L180	2nd_Lugg_Cmpt	561247	male	L256	ParcelRackRH	562756	male
L181	2nd_Lugg_Cmpt	561247	male	L280	Driver_Area	561690	male
L182	1st_Lugg_Cmpt	561247	male	L282	3rd_LH_Lugg_Cmpt	561690	male
L183	1st_Lugg_Cmpt	561247	male	L283	Service_Cmpt	562485	male



# CONNECTORS LIST

No	Location	Part #	Gender	No	Location	Part #	Gender
L285.A	Rear_Vehicle	562835	female	R14	WCLCmpt	564496	male
L285.B	Rear_Vehicle	562834	male	R15	RJB	563616	female
L286.A	Rear_Vehicle	562835	female	R16	RJB	563616	female
L286.B	Rear_Vehicle	562834	male	R21	FJB	560525	male
L298A	EngineCmpt	563590	female	R23A	FJB	564496	male
L301	Dash	560898	male	R26	Evap_Cmpt	564496	male
L303	EngineCmpt	563590	female	R27	RHConsole	564496	male
L304	EngineCmpt	563590	female	R28	RrSeat	563409	male
L305.H	Enginecmpt	563764	female	R29	RJB	563409	male
L305.P1	Enginecmpt	562477	male	R30	FJB	564496	male
L306	RJBCmpt	561247	male	R31	FJB	564496	male
L310	FrInterRoof	560898	male	R34	RJB	564210	male
L310A	FrInterRoof	561552	female	R36	FJB	564496	male
L350.A	RrAxleCmpt	564552	male	R37	FJB	564496	male
L350.B	RrAxleCmpt	563340	male	R44	P.RackFrLH	564496	male
L350.C	RrAxleCmpt	562251	male	R45	P.RackFrLH	564496	male
L391	Parcel_Rack	560898	male	R47	WCLCmpt	564496	male
Mo3	Dash	561667	female	R50	FJB	564496	male
Mo4	Dash	564161	male	R51	P.RackFrLH	564496	male
Mo7	CondCmpt	561890	male	R52	P.RackFrLH	564496	male
Mo8	CondCmpt	561890	male	R55	FJB	564496	male
Mo10	P.RackLH	561515	male	R57	RJB	564496	male
Mo11	P.RackRH	561515	male	R65	P.RackFrLH	564496	male
Mo12	EvapCmpt	561690	male	R66	P.RackFrLH	564496	male
Mo17	Service_Cmpt	563626	male	R210	Parcel_Rack_LH	560525	male
Mo19	Service_Cmp	562474	male	Res2	Parcel_Rack_JB	563205	male
Mo20	Service_Cmpt	562474	male	Res3.A	ParcelRack	563590	female
Mo22	RH_Console	561186	male	Res4	RH_Console	563590	female
Mo27	CondCmpt	561890	male	Res6	RJB	563590	female
Mo28	CondCmpt	561890	male	Res7	Dash	563590	female
Mo29	RJB	563590	female	Res14	Evap_Cmpt	563205	male
Mo37	ServiceCmpt	562477	male	Res20	Parcel_Rack	563590	female
Mo38	WCLUperDoor	564161	male	Res31	UreaCmpt	562350	male
Mo65	EngineCmpt	568089	male	Res32	UreaCmpt	563764	female
Mo67	EngineCmpt	568089	male	Res37.A	Front_Clearance	561690	male
Mo68	EngineCmpt	568089	male	Res37.B	Front_Clearance	561690	male
Mo69	EngineCmpt	568089	male	Res46	RrAxleCmpt	563590	female
Mo70	EngineCmpt	568089	male	Res53	Dash	563590	female
Mo71	EngineCmpt	568089	male	RT34.1	FJB	561904	female
Mo72	EngineCmpt	568089	male	RT34.2	FJB	561904	female
Mo73	EngineCmpt	568089	male	RT34.3	FJB	561904	female
R1	R1	562486	female	Se2	LH_Console	561566	female
R3	RJB	563409	male	Se11.A	Cond_Cmpt	564460	female
R12	Evap_Cmpt	563409	male	Se11.B	Cond_Cmpt	564460	female
R13	WCLCmpt	564496	male	Se11.C	Cond_Cmpt	564460	female

# CONNECTORS LIST

No	Location	Part #	Gender	No	Location	Part #	Gender
Se13	Engine_Cmpt	562350	male	Se78	PneuPlate	563159	female
Se14.A	Driver_Area	561782	male	Se79	Front_Axle	563340	male
Se14.B	Driver_Area	561781	female	Se83	FrontAxle	642190	female
Se18	PneuPlate	561566	female	Se84	FrontAxle	642190	female
Se19_P	Service_Cmpt	563677	male	Se85	RearAxle	642190	female
Se19_S	ServiceCmpt	563677	male	Se86	RearAxle	642190	female
Se20	Head_Lamp_RH	562426	male	Se87	RearAxle	642190	female
Se21	Dash	561248	female	Se88	RearAxle	642190	female
Se22	CondCmpt	562877	female	Se89	EngineCmpt	562350	male
Se23	Engine_Cmpt	563159	male	Se94	WCLUpperdoor	562877	female
Se24	EvapCmpt	563758	female	Se100	WCLUpperdoor	562479	female
Se25	Passenger_Area	561248	female	shell1	RJB	561932	male
Se29	Engine_Cmpt	561566	female	shell1_1	Luggage_Cmpt	561690	male
Se30	EngineCmpt	562877	female	So4	RH_Console	641385	male
Se31	EngineCmpt	562877	female	So5	RH_Console	641385	male
Se32	Rear_Axle_Cmpt	562426	male	So6	RH_Console	641385	male
Se33	Rear_Axle_Cmpt	562856	male	So7	Service_Cmpt	561566	female
Se34	Rear_Axle_Cmpt	562427	male	So8	ServiceCmpt	641385	male
Se35	Rear_Axle_Cmpt	562426	male	So9	EngineCmpt	560016	female
Se36	Rear_Axle_Cmpt	562427	male	So10	CondCmpt	562485	male
Se37	Front_Axle_LH	641132	female	So11	Cond_Cmpt	561566	female
Se38	Front_Axle_RH	641132	female	So13	Evap_Cmpt	563204	female
Se39	Rear_Axle_LH	641132	female	So15	PneuPlate	641385	male
Se40	Rear_Axle_LH	641132	female	So16	PneuPlate	641385	male
Se45.A	ServiceCmpt	563409	male	So17	PneuPlate	562848	male
Se49	Engine_Cmpt	561690	male	So20	PneuPlate	641385	male
Se50.A	FJB	561904	female	So21	Front_Axle_Cmpt	564046	female
Se50.B	FJB	561904	female	So22	Front_Axle_Cmpt	564046	female
Se51	FJB	563589	male	So23	Rear_Axle_Cmpt	564046	female
Se53	Service_Cmpt	563159	female	So24	Rear_Axle_Cmpt	564046	female
Se54	Service_Cmpt	563159	female	So27	RearAxleCmpt	564045	female
Se55	Service_Cmpt	563159	female	So29	WCLCmpt	641385	male
Se56	WCLCmpt.	562479	female	So50	RearAxleCmpt	564046	female
Se57	Pneumatic Panel	563159	female	So52	FrontAxleCmpt	564045	female
Se62	WCLLuggDoor	561690	male	So53	Rear_Axle_Cmpt	641385	male
Se63	EngineCmpt	641132	female	So55	PneuPlate	562848	male
Se64	EngineCmpt	641132	female	So70	PneumaticPanel	641385	male
Se65	Dash	564042	female	spBar2	Engine_Cmpt	564135	male
Se66	FrontAxle	564039	female	spBar3	Parcel_Rack_LH	564135	male
Se67	FJB	563159	female	spBar4	EngineCmpt	564135	male
Se69	FJB	563159	female	spBar5	EngineCmpt	564135	male
Se76	EntranceDoor	562479	female	spBar6	EngineCmpt	564135	male
Se77	FrontVehicle	563159	female	spBar7	UreaCmpt	564135	male

# CONNECTORS LIST

No	Location	Part #	Gender	No	Location	Part #	Gender
spBar11	RearVehicle	564135	male	Spk23.A	FroutsideLH	563994	male
spBar12	RearVehicle	564135	male	Spk23.B	FroutsideRH	563996	female
spBar13	EngineCmpt	564135	male	Spk24	Froutsidecenter	563994	male
spBar14	EngineCmpt	564135	male	Spk25	Froutsidecenter	563994	male
spBar15	EngineCmpt	564135	male	Sw2	Dash	562763	male
spBar16	EngineCmpt	564135	male	Sw4	Dash	562763	male
spBar19	CondensorCmpt	564135	male	Sw10A	LH_Console	562763	male
spBar20	CondensorCmpt	564135	male	Sw12	Dash	562763	male
spBar21	CondensorCmpt	564135	male	Sw13	Dash	562763	male
spBar22	EngineCmpt	564135	male	Sw14	Dash	562763	male
spBar23	EngineCmpt	564135	male	Sw16	RJB	563135	male
spBar24	FJB	564135	male	Sw16	Dash	562763	male
spBar25	EngineCmpt	564135	male	Sw17	Dash	562763	male
spBar26	FrAxleCmpt	564135	male	Sw20	Dash	562763	male
spBar27	FrAxleCmpt	564135	male	Sw24	Dash	562763	male
Spk1_L	Parcel_Rack_LH	563994	male	Sw25	Dash	562763	male
Spk1_R	Parcel_Rack_RH	563994	male	Sw29	Dash	562763	male
Spk2_L	Parcel_Rack_LH	563994	male	Sw30	LHConsol	562763	male
Spk2_R	Parcel_Rack_RH	563994	male	Sw34	FrEntranceDoor	563832	female
Spk3_L	Parcel_Rack_LH	563994	male	Sw38	LH_Console	562763	male
Spk3_R	Parcel_Rack_RH	563994	male	Sw41	LH_Console	562749	male
Spk4_L	Parcel_Rack_LH	563994	male	Sw42	WCL_Cmpt	561635	female
Spk4_R	Parcel_Rack_RH	563994	male	Sw44.A	FJB	562403	female
Spk5_L	Parcel_Rack_LH	563994	male	Sw45.A	3rd_Lugg_Cmpt	562403	female
Spk5_R	Parcel_Rack_RH	563994	male	Sw46.A	3rd_Lugg_Cmpt	562403	female
Spk6_L	Parcel_Rack_LH	563994	male	Sw46B.A	3rdLuggCmpt.	562403	female
Spk6_R	Parcel_Rack_RH	563994	male	Sw46B.B	3rdLugg.Cmpt.	562403	female
Spk7_L	Parcel_Rack_LH	563994	male	Sw49.A	2nd_Lugg_Cmpt	562403	female
Spk7_R	Parcel_Rack_RH	563994	male	Sw50.A	2nd_Lugg_Cmpt	562403	female
Spk8_L	Parcel_Rack_LH	563994	male	Sw51.A	1st_Lugg_Cmpt	562403	female
Spk8_R	Parcel_Rack_RH	563994	male	Sw52.A	1st_Lugg_Cmpt	562403	female
Spk9_L	Parcel_Rack_LH	563994	male	Sw58	EngineCmpt.	563135	male
Spk9_R	Parcel_Rack_RH	563994	male	Sw59	EngineCmpt.	563135	male
Spk10_L	Parcel_Rack_LH	563994	male	Sw64.A	Service_Cmpt	560815	female
Spk10_R	Parcel_Rack_RH	563994	male	Sw64.B	Service_Cmpt	560815	female
Spk11_L	Parcel_Rack_LH	563994	male	Sw70	Dash	562763	male
Spk11_R	Parcel_Rack_RH	563994	male	Sw71	EngineCmpt	562348	female
Spk12_L	Parcel_Rack_LH	563994	male	Sw80A	EngineCmpt	562763	male
Spk12_R	Parcel_Rack_RH	563994	male	Sw81.A	Dash	562905	male
Spk13_L	Parcel_Rack_LH	563994	male	Sw81.B	Dash	562905	male
Spk13_R	Parcel_Rack_RH	563994	male	Sw82A	RJB	563618	male
Spk14_L	Parcel_Rack_LH	563994	male	Sw83A	Dash	562581	male
Spk14_R	Parcel_Rack_RH	563994	male	Sw84	EngineCmpt.	563135	male
Spk22	Dash	563994	male	Sw85	LH_Console	562749	male

# CONNECTORS LIST

No	Location	Part #	Gender	No	Location	Part #	Gender
Sw95.A	WCLDoor	561626	female	Tab70b.A	ParcelRack	561626	N/A
Sw95.B	WCLDoor	561626	female	TermL152B	ParcelRackLH	562505	N/A
Sw96.A	WCL_Door	562615	female	TermL249B	ParcelRackRH	562505	N/A
Sw96.B	WCL_Door	562615	female	USB.MOD	1stseat	561690	male
Sw96.C	WCLDoor	562615	female	USB.MOD	1stseat	561566	female
Sw97.A	WCLSystem	562615	female	USB.WCL.F	PassengerArea	561690	male
Sw97.B	WCLSystem	562615	female	USB.WCL.F	PassengerArea	561566	female
Sw97.C	WCLSystem	562615	female	USB.WCL.F	PassengerArea	561690	male
Sw98.A	WCLSystem	561626	female	USB.WCL.F	PassengerArea	561566	female
Sw98.B	WCLSystem	561626	female	USB1L	PassengerArea	563025	male
Sw103	LH_Console	562763	male	USB1R	PassengerArea	563025	male
Sw105	Dash	563590	female	USB2	Passenger_Area	563025	male
Sw116.A	Luggages	560079	female	USB2L	Passenger_Area	561690	male
Sw116.B	Luggages	560079	female	USB2R	Passenger_Area	561690	male
Sw122	Dash	562763	male	USB3L	Passenger_Area	561690	male
Sw123	Dash	562763	male	USB3R	Passenger_Area	561690	male
Sw137	Dash	562763	male	USB4L	Passenger_Area	561690	male
Sw138	FJB	561690	male	USB4R	Passenger_Area	561690	male
Sw139	FJB	561690	male	USB5L	Passenger_Area	561690	male
Sw140	FJB	561566	female	USB5R	Passenger_Area	561690	male
Sw141	FJB	561690	male	USB6L	Passenger_Area	561690	male
Sw142	LHConsole	562763	male	USB6R	Passenger_Area	561690	male
Sw143	Driver_Area	562485	male	USB7L	Passenger_Area	561690	male
Sw144	FJB	561690	male	USB7R	Passenger_Area	561690	male
Sw152	Driver_Area	562471	male	USB8L	Passenger_Area	563025	male
Sw152.	Driver_Area	562471	male	USB9L	Passenger_Area	563025	male
Sw161	Dash	562763	male	USB9R	Passenger_Area	563025	male
sym691_1	Parcel_Rack_LH	562464	male	USB10L	Passenger_Area	561690	male
sym762_1	FrInterRoof	561611	male	USB10R	Passenger_Area	561690	male
sym762_1	FrInterRoof	561610	female	USB11L	Passenger_Area	561690	male
sym780_1	FrInterRoof	563040	female	USB11R	Passenger_Area	561690	male
sym781_1	FrInterRoof	563071	male	USB12L	Passenger_Area	561690	male
sym797_2	ParcelRack	565180	female	USB12R	Passenger_Area	561690	male
sym803_2	ParcelRack	565180	female	USB13L	Passenger_Area	561690	male
sym814_2	ParcelRack	565180	female	USB13R	Passenger_Area	561690	male
sym815_2	ParcelRack	565180	female	USB14L	Passenger_Area	561690	male
sym816_2	ParcelRack	565180	female	USB14R	Passenger_Area	561690	male
sym824_2	ParcelRack	565180	female	USB_Mod	Passenger_Area	561690	male
sym826_2	ParcelRack	565180	female	USB_Mod	Passenger_Area	561566	female
Tab1.A	ParcelRack	561626	N/A	USB_WCL	Passenger_Area	563025	male
tab69.A	ParcelRack	565180	N/A	VECF1	FJB	563186	male
tab70.A	ParcelRack	565180	N/A	VECF2	FJB	563183	male
Tab70a.A	ParcelRack	561626	N/A	VECF3	FJB	563185	male

# CONNECTORS LIST

No	Location	Part #	Gender	No	Location	Part #	Gender
VECF4	FJB	563182	male				
VECF9	FJB	563448	male				
VECF10	FJB	563181	male				
VECF11	FJB	563184	male				
VECF12	FJB	563187	male				
VECPR1	Parcelrack_LH	563715	male				
VECPR2	Parcelrack_LH	563716	male				
VECPR3	Parcelrack_LH	563718	male				
VECPR4	Parcelrack_LH	563714	male				
VECR1	RJB	563186	male				
VECR2	RJB	563183	male				
VECR3	RJB	563185	male				
VECR4	RJB	563182	male				
VECR9	RJB	563448	male				
VECR10	RJB	563181	male				
VECR11	RJB	563184	male				
VECR12	RJB	563187	male				
Y80	Engine_Cmpt	563789	male				
Y81	Cond_Cmpt	563793	male				

# DIODES LIST

No	Location	Part #	Function	Page					
D1	FJB	561740	AccessoriesDiode	3,2					
D2	FJB	561740	DrvLiqSol	18,1					
D3	RJB	561740	FrTrailer	26,2					
D4	RHConsole	561740	WiperSpeed	34,1					
D5	RHConsole	561740	WiperSpeed	34,1					
D8	Evap_Cmpt	561740	P-RackRefgvalve	18,3					
D10	RJB	561740	FrTrailer	26,2					
D11	Evap_Cmpt	561740	DiodePass.Liq.Sol	18,2					
D12	FJB	565973	ElechHorn	9,1					
D13	FJB	561740	FrClearancelgts	26,1					
D14	FJB	561740	FrClearancelgts	9,1					
D15	RJB	561740	FrTrailer	26,2					
D16	RJB	561740	PurgeTank	37,1					
D17	RJB	561740	FrTrailer	26,2					
D18	RJB	561740	FrTrailer	26,2					
D19	Evap_Cmpt	561740	Wat_Pump	18,2					
D21	RJB	561740	FrTrailer	26,4					
D22	RJB	561740	FrTrailer	26,4					
D23	RJB	561740	FrTrailer	26,4					
D24	RJB	561740	FrTrailer	26,4					
D25	Evap_Cmpt	561740	Wat_Pump	18,2					
D26	RJB	561740	FrTrailer	18,3					
D27	RJB	561740	FrTrailer	18,3					
D28	RJB	561740	FrTrailer	26,4					
D29	RJB	561740	SuppressorDiodeUnloaderRH	18,2					
D30	Evap_Cmpt	561740	SuppressorDiodeWaterPump	18,2					
D31	RJB	561740	A/Cclutch	18,2					
D41	FJB	561740	IgnitionDiode	3,2					
D42	FJB	561740	IgnitionDiode	3,2					
D43	FJB	565973	IgnitionDiode	3,2					
D44	FJB	561740	IgnitionDiode	3,2					
D45	FJB	561740	StartingAid	43,1					
D47	FJB	565973	StartingAid	43,1					

# DIODES LIST

No	Location	Part #	Function	Page					
D1	FJB	561740	AccessoriesDiode	3.2					
D2	FJB	561740	DrvLiqSol	18.1					
D3	RJB	561740	FrTrailer	26.2					
D4	RHConsole	561740	WiperSpeed	34.1					
D5	RHConsole	561740	WiperSpeed	34.1					
D8	Evap_Cmpt	561740	P-RackRefgvalve	18.3					
D10	RJB	561740	FrTrailer	26.2					
D11	Evap_Cmpt	561740	DiodePass.Liq.Sol	18.2					
D12	FJB	565973	AFSS Signal	9.1					
D13	FJB	561740	FrClearanceLgts	26.1					
D14	FJB	561740	FrClearanceLgts	9.1					
D15	RJB	561740	FrTrailer	26.2					
D16	RJB	561740	PurgeTank	37.1					
D17	RJB	561740	FrTrailer	26.2					
D18	RJB	561740	FrTrailer	26.2					
D19	Evap_Cmpt	561740	Wat_Pump	18.2					
D21	RJB	561740	FrTrailer	26.4					
D22	RJB	561740	FrTrailer	26.4					
D23	RJB	561740	FrTrailer	26.4					
D24	RJB	561740	FrTrailer	26.4					
D25	Evap_Cmpt	561740	Wat_Pump	18.2					
D26	RJB	561740	FrTrailer	18.3					
D27	RJB	561740	FrTrailer	18.3					
D28	RJB	561740	FrTrailer	26.4					
D29	RJB	561740	SuppressorDiodeUnloaderRH	18.2					
D30	Evap_Cmpt	561740	SuppressorDiodeWaterPump	18.2					
D31	RJB	561740	A/Cclutch	18.2					
D41	FJB	561740	IgnitionDiode	3.2					
D42	FJB	561740	IgnitionDiode	3.2					
D43	FJB	565973	IgnitionDiode	3.2					
D44	FJB	561740	IgnitionDiode	3.2					
D45	FJB	561740	StartingAid	43.1					
D47	FJB	565973	StartingAid	43.1					





# RESISTORS LIST

No	Location	Part #	Function	Page				
Res2	Parcel_Rack	563205	Parcel_Rack_Fan	18.3				
Res3	Parcel_Rack	563593	CAN_Network	6.1				
Res4	RH_Console	563593	CAN_Network	6.1				
Res6	RJB	563593	DBus_Network	6.2				
Res7	Dash	563593	J1939Network	6.2				
Res10	Dash	562892	KeypadBacklighting	10.1				
Res14	Evap_Cmpt	563205	CondFans	18.2				
Res15	Engine_Cmpt	563587	Flamedetection	38.1				
Res20	Dash	563593	CAN1Network	42.1				
Res24	RJB	565156	FuelTankGnd	2.2				
Res25	FJB	562470	StairFanCtrl	18.2				
Res26	FJB	561897	StairFanCtrl	18.2				
Res31	Fuel_Tank	41123	HeatedelementforUreatank	14.2				
Res32	Fuel_Tank	41123	HeatedelementforUreatank	14.2				
Res37	Front_Clearance	*opt*	UpperDefrost	18.4				
Res46	FJB	563593	J1939Network	39.1				
Res53	Dash	563593	J2284Network	6.2				

# RELAYS LIST

No	Location	Part #	Function	Page					
R1	RJB	560843	MasterRelay	3,1					
R3	RJB	563348	12vIgn/Acc	3,1					
R12	Evap_cmpt.	563348	EvaporatorRelay	18,2					
R13	WCLPump	563332	WCLUpperDoorLOCK	36,1					
R14	WCLPump	563332	WCLUpperDoorLOCK	36,1					
R20	Evap_Cmpt	563332	Wat.Pump	18,2					
R21	FJB	560493	24vRelayLatching	3,2					
R22	FJB_VECF	563269	Eculgn	4,1					
R23	FJB_VECF	563269	Shutdown	4,1					
R24	FJB_VECF	563269	Spare12WUP	4,1					
R25	FJB_VECF	563269	24VIgn	4,2					
R26	Evap_Cmpt	563332	Pre-Heat	18,2					
R27	RHConsole	563332	Wipers	34,1					
R28	RJB	563348	ENGINE RUN	40,2					
R29	RJB	563348	Preheater	14,1					
R30	FJB	563332	12vENGRUN	4,1					
R31	FJB	563332	12vIGN	4,1					
R34	RJB	564218	12vEngEcu	3,2					
R36	FJB	563269	Fire_Extin	9,1					
R37	FJB	563269	Electhorn	9,1					
R44	Parcel_Rack_LH	563332	IVN/MOTOROLAAUDIO+RELAY	35,8					
R45	Parcel_Rack_LH	563332	IVN/MOTOROLAAUDIO-RELAY	35,8					
R47	WCLPump	563332	WCLDoorOpen	36,1					
R50	FJB	563332	StopRequest	22,2					
R51	Parcel_Rack_LH	563332	MOTOROLARELAY	35,8					
R52	Parcel_Rack_LH	563332	FAREBOXRELAY	35,8					
R55	FJB	563332	StairFanCtrl	18,2					
R57	Evap_Cmpt	563332	ProFuel	14,1					
R61	Parcel_Rack_VECPR	563269	*opt*	5,2					
R65	Parcel_Rack_LH	563269	12VWupRELAY	5,2					
R66	Parcel_Rack_LH	563269	12VDISMRELAY	5,2					
R210	Parcel_Rack_LH	560493	24vRelayLatching	5,2					
R_Starter	RJB	564095	StartCtrl	3,2					
RT34	FJB	563890	TimerOutsideDoorSw	29,1					

# RELAYS LIST

No	Location	Part #	Function	Page					
R1	RJB	560843	MasterRelay	3.1					
R3	RJB	563348	12vIgn/Acc	3.1					
R12	Evap_cmpt.	563348	EvaporatorRelay	18.2					
R13	WCLPump	563332	WCLUpperDoorLOCK	36.1					
R14	WCLPump	563332	WCLUpperDoorLOCK	36.1					
R15	RJB	564350	BATT DISCONNECT	1.1					
R16	RJB	564350	BATT DISCONNECT	1.1					
R20	Evap_Cmpt	563332	Wat.Pump	18.2					
R21	FJB	560493	24vRelayLatching	3.2					
R22	FJB_VECF	563269	Eculgn	4.1					
R23	FJB_VECF	563269	Shutdown	4.1					
R24	FJB_VECF	563269	Spare12WUP	4.1					
R25	FJB_VECF	563269	24VIgn	4.2					
R26	Evap_Cmpt	563332	Pre-Heat	18.2					
R27	RHConsole	563332	Wipers	34.1					
R28	RJB	563348	ENGINE RUN	40.2					
R29	RJB	563348	Preheater	14.1					
R30	FJB	563332	12vENGRUN	4.1					
R31	FJB	563332	12vIGN	4.1					
R34	RJB	564218	12vEngEcu	3.2					
R36	FJB	563269	Fire_Extin	9.1					
R37	FJB	563269	Electhorn	9.1					
R44	Parcel_Rack_LH	563332	IVN/MOTOROLAAUDIO+RELAY	35.8					
R45	Parcel_Rack_LH	563332	IVN/MOTOROLAAUDIO-RELAY	35.8					
R47	WCLPump	563332	WCLDoorOpen	36.1					
R50	FJB	563332	StopRequest	22.2					
R51	Parcel_Rack_LH	563332	MOTOROLARELAY	35.8					
R52	Parcel_Rack_LH	563332	FAREBOXRELAY	35.8					
R55	FJB	563332	StairFanCtrl	18.2					
R57	Evap_Cmpt	563332	ProFuel	14.1					
R61	Parcel_Rack_VECPR	563269	*opt*	5.2					
R65	Parcel_Rack_LH	563269	12VWupRELAY	5.2					
R66	Parcel_Rack_LH	563269	12VDISMRELAY	5.2					
R210	Parcel_Rack_LH	560493	24vRelayLatching	5.2					
R_Starter	RJB	564095	StartCtrl	3.2					
RT34	FJB	563890	TimerOutsideDoorSw	29.1					

# FUSES LIST

No	Location	Part #	Function	Rating	Page
F1	3rd_Lugg	564520	Ultracap	300A	43,1
F101	RJB	564520	PwrR1	300A	3,1
F103	RJB	564520	ULTRACAP	300A	3,1
F129	RJB	563284	AFSS	15amp	38,2
F199	RJB	562597	RADFans	300A	13,1
F209	RJB	562597	PreHeat	150A	14,1

# Wire identification chart

*\*Note that the identification comes from the uphill component.*

Wire identification exemple: 12 - A47J1.8 - 16

Voltage	Circuit number	Wire size
0		0000
5	<b>Ground circuits:</b>	000
0/12	Electronic = Use I/O module number followed by an "R" and pin number. (ex: A47RJ1.8, A54RJ2.14)	00
0/24	Electronic ground studs = Use number "00" followed with the stud location and sequential number. (ex: 00R1, 00F4)	0
12	Chassis = Use number "0" followed by the ground stud location and sequential number. (ex: 0EV1, 0FH2)	1
24		2
120	<b>Power and voltage carrying circuits:</b>	3
ANA	Power distribution = Use uphill component identification as circuit name. (ex: F96, CB22)	4
BBUS	Multiplex outputs = Use output module number and pin number as circuit name. (ex: A55J1.4, A49J2.9)	6
DATA	Relays, diodes, resistors and any other component outputs =	8
DBUS	Use component name and pin number as circuit name. (ex: Sw55.A, R30.87, D12.B)	10
J1587	<b>Networks:</b>	12
J1939	DL0 = Bbus mux DL7 = Engine subnet	14
J2284	DL1 = J1939 DL9 = Power train subnet	16
LIN	DL2 = J2284 900 / 901 = J1587	18
PWM	DL3 = Dbus mux	20
GND		22
...OTHER		24

# Batteries and alternators

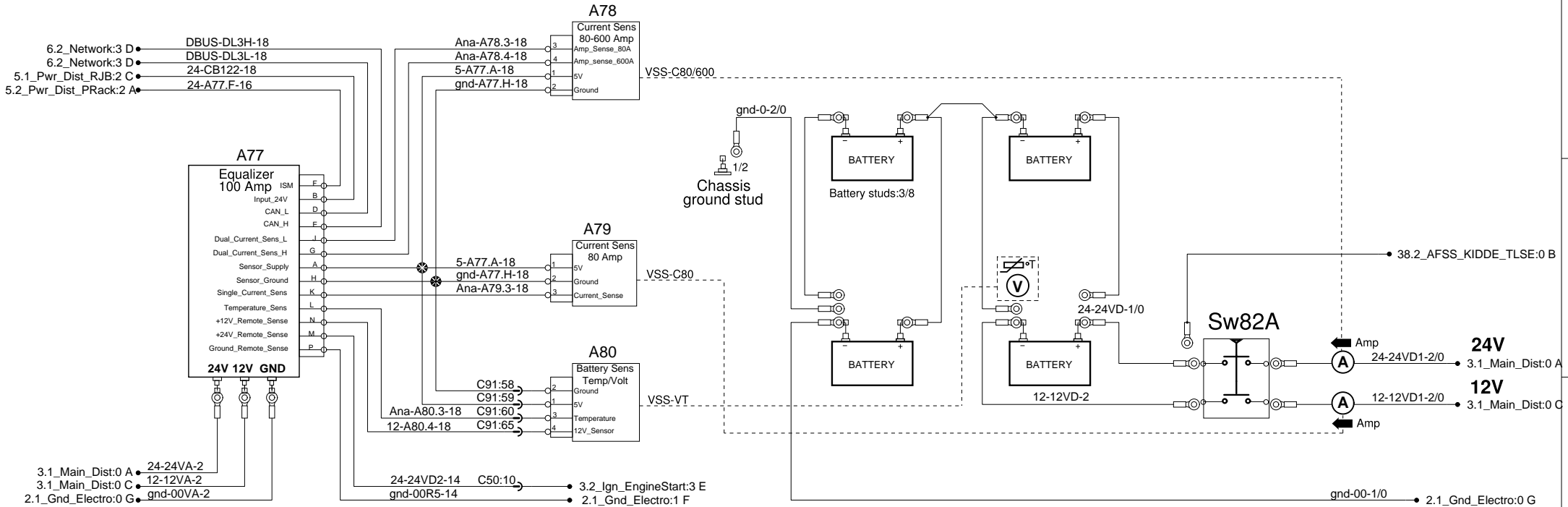

## RJB Fan

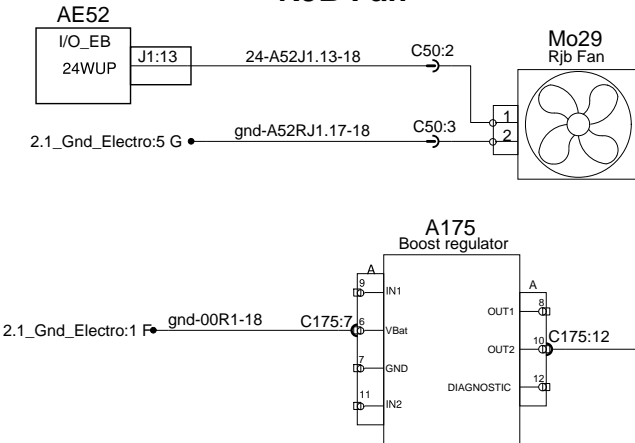

## Alternators

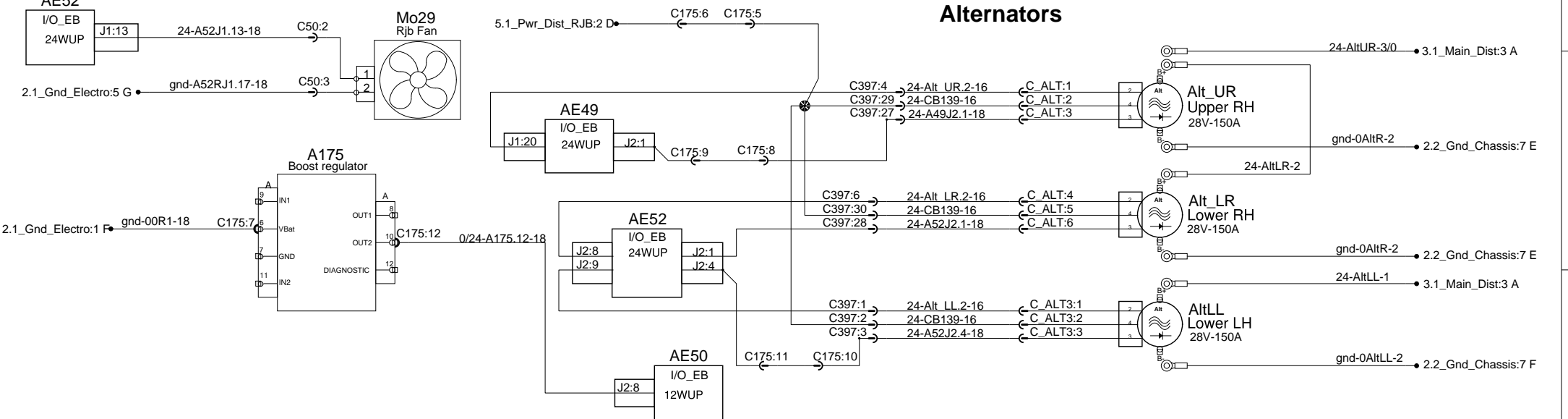

## Batteries and alternators

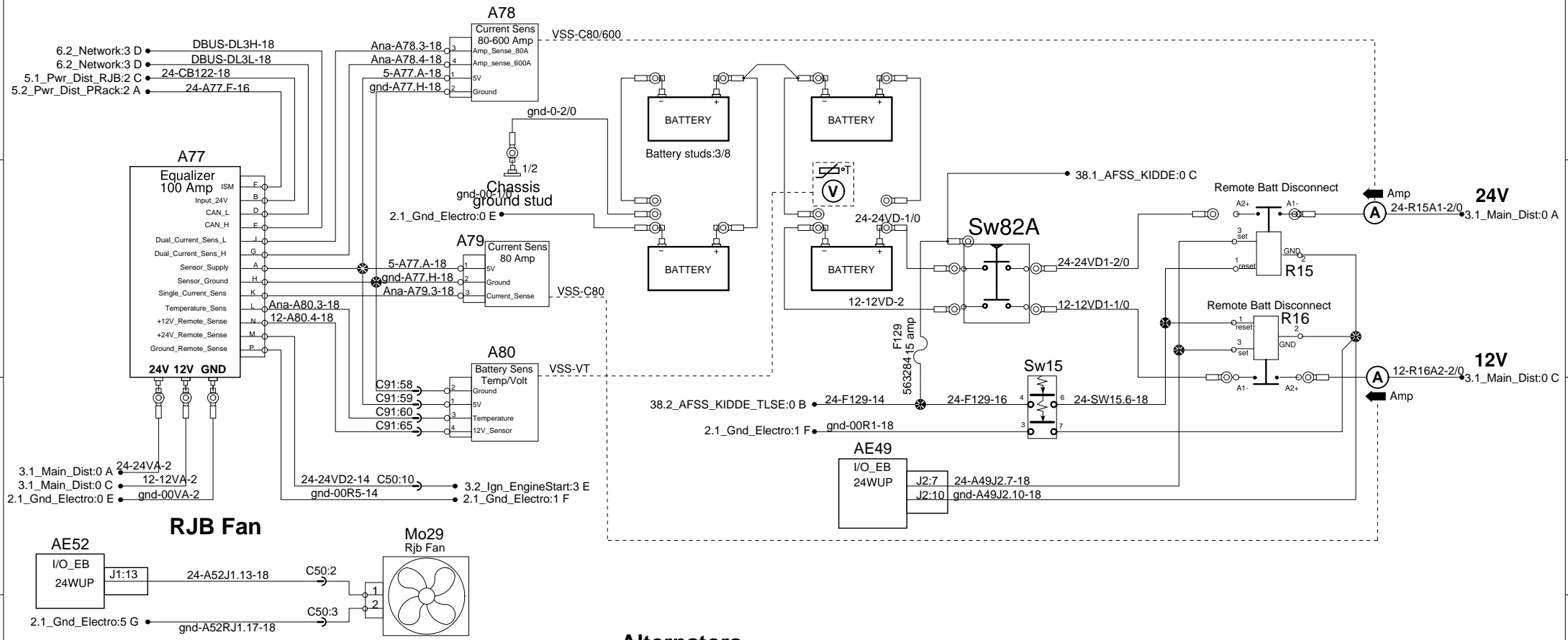

## Alternators

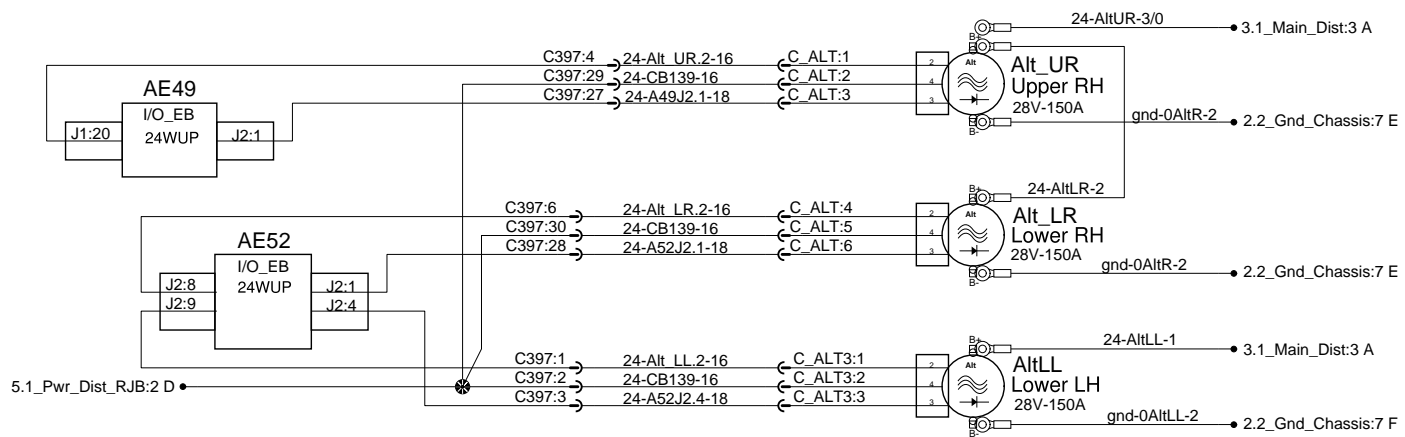

# Batteries and alternators

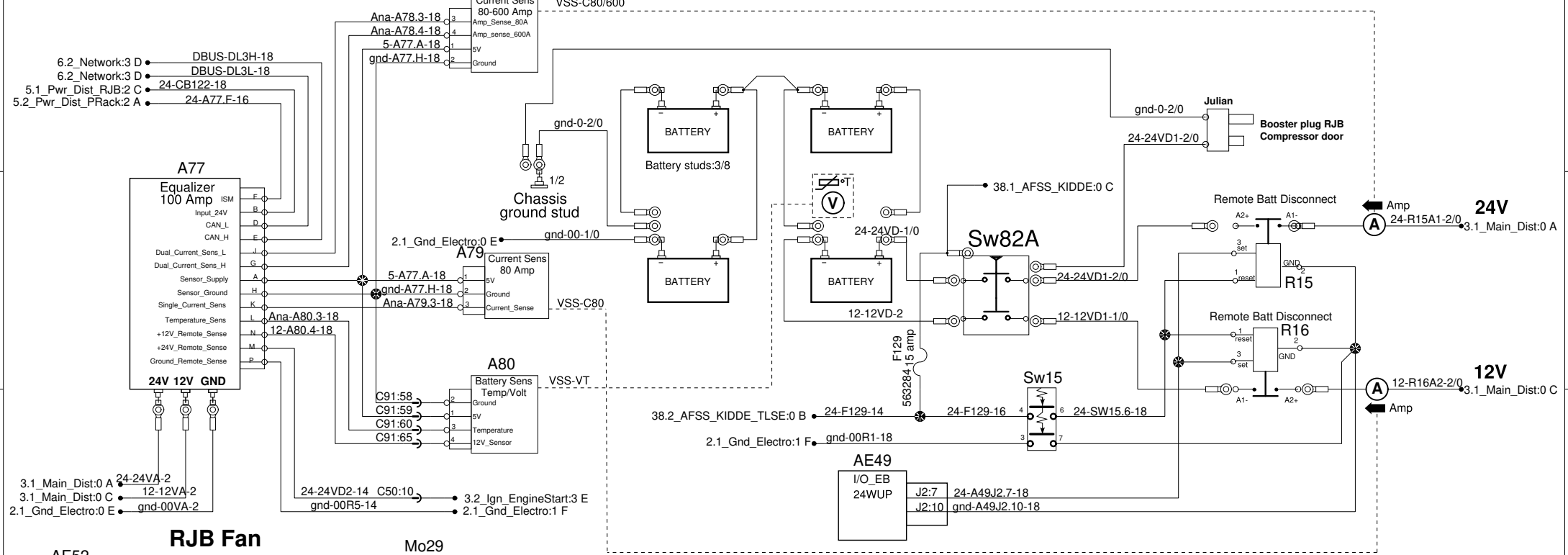

## RJB Fan

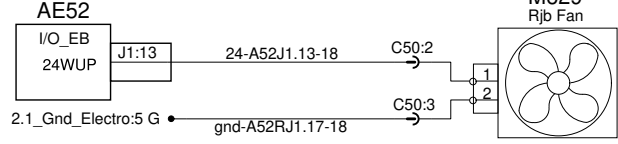

## Alternators

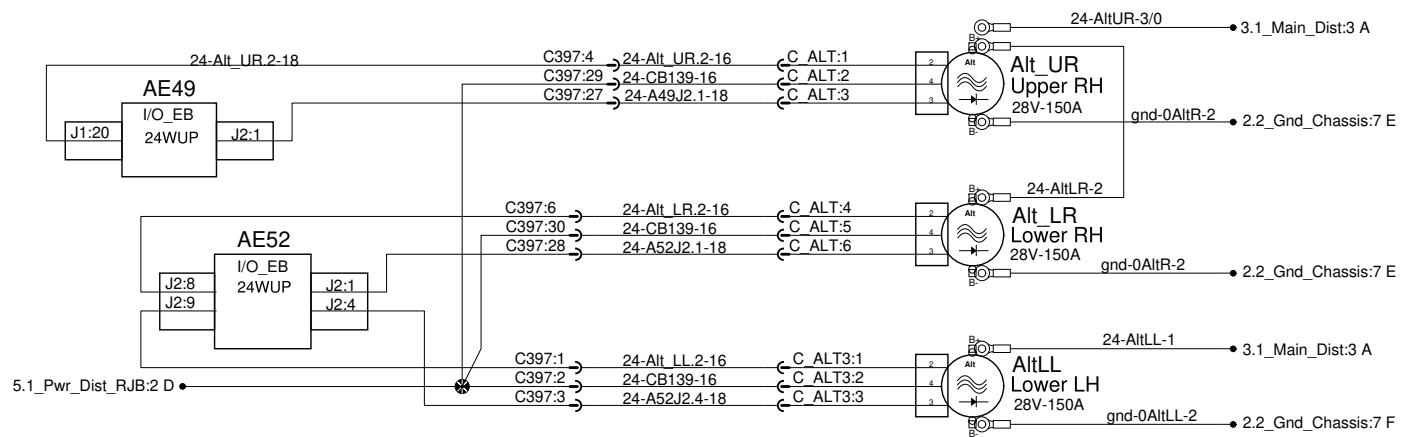



\*\*Ground distribution:\*\*

0-Electric gnd  
00- Electronic Gnd

A-Dash - Lh console harness  
F-Front junction box harness  
FH-Front harness  
R-Rear junction box harness  
FR-Front to rear  
P-Parcel Rack  
RS-RJB to Rear Seat

### Dash harness

- gnd-00A2-16 → 23.1\_Indirect\_Lights:0 B
- gnd-00A-18 → 7.1\_Mux\_Power:4 B
- gnd-00A-18 → 22.2\_Reading\_lamps:2 E
- gnd-00A-18 → 22.2\_Reading\_lamps:4 F
- gnd-00A-18 → 16.2\_Snow\_Chains:2 C
- gnd-00A-18 → 19.1\_Driver\_Its:0 D
- gnd-00A-18 → 10.1\_Cluster:3 B
- gnd-00A-18 → 3.2\_Ign\_EngineStart:0 B
- gnd-00A-18 → 6.2\_Network:4 C
- gnd-00A-18 → 9.1\_Horn:1 C

- gnd-00A-18 → 12.1\_Brake:0 B
- gnd-00A-18 → 10.1\_Cluster:1 B
- gnd-00A-18 → 16.1\_ESP:0 A
- gnd-00A-18 → 14.1\_Engine\_Ecu\_VECU5:1 C
- gnd-00A-18 → 22.2\_Reading\_lamps:6 E
- gnd-00A-18 → 14.1\_Engine\_Ecu:6 E
- gnd-00A-18 → 12.1\_Brake:2 A
- gnd-00A-18 → 26.3\_Backup\_Warnings:1 B
- gnd-00A-18 → 26.1\_Front\_Lighting:0 D
- gnd-00A-18 → 26.1\_Front\_Lighting:1 A

### Lh console harness

- gnd-00A-18 → 29.1\_Entrance\_door:0 D
- gnd-00A-18 → 12.1\_Brake:1 D
- gnd-00A-18 → 36.1\_WCL\_Ricon:2 A
- gnd-00A-18 → 32.1\_Kneeling:1 A
- gnd-00A-18 → 30.1\_Drivers\_Window:1 B

### Front harness

- gnd-00FH-16 → 9.1\_Horn:4 D
- gnd-00FH-18 → 34.1\_wiper\_washer:2 E
- gnd-00FH-18 → 12.1\_Brake:1 C
- gnd-00FH2-10 → 7.1\_Mux\_Power:2 C
- gnd-00FH2-10 → 7.1\_Mux\_Power:2 C
- gnd-00FH1-12 → 18.1\_Defroster:2 B
- gnd-00FH1-12 → 28.1\_Dest\_Signs\_Hanover\_Farebox:2 D

### FJB harness

- gnd-00F1-12 → 7.1\_Mux\_Power:1 C
- gnd-00F1-12 → 7.1\_Mux\_Power:1 D
- gnd-00F2-12 → 7.1\_Mux\_Power:1 D
- gnd-00F2-12 → 7.1\_Mux\_Power:1 E
- gnd-00F4-16 → 35.8\_ITS\_IVN:6 E
- gnd-00F4-16 → 42.1\_ELD\_Gateway:2 D
- gnd-00F3-16 → 7.1\_Mux\_Power:1 B
- gnd-00F-14 → 16.1\_ESP:1 B
- gnd-00F-18 → 32.1\_Kneeling:1 C

- gnd-00F-18 → 14.1\_Engine\_Ecu\_VECU5:3 C
- gnd-00F-18 → 4.1\_Dist\_12V\_FJB:2 C
- gnd-00F-18 → 29.1\_Entrance\_door:1 A
- gnd-00F-18 → 12.1\_Brake:1 E
- gnd-00F-18 → 18.2\_HvacPass:0 B
- gnd-00F-18 → 4.1\_Dist\_12V\_FJB:3 A
- gnd-00F-18 → 4.1\_Dist\_12V\_FJB:4 B
- gnd-00F-18 → 9.1\_Horn:1 B
- gnd-00F-18 → 38.1\_AFSS\_KIDDE:2 D
- gnd-00F-16 → 5.2\_Pwr\_Dist\_PRRack:2 A
- gnd-00F-18 → 42.1\_ELD\_Gateway:5 C

### RJB harness

- gnd-00VA-2 → 1.1\_batteries:0 C
- gnd-00-1/0 → 1.1\_batteries:2 B
- gnd-00R1-18 → 3.2\_Ign\_EngineStart:1 C
- gnd-00R1-18 → 12.1\_Brake:1 B
- gnd-00R1-18 → 6.2\_Network:0 B
- gnd-00R1-14 → 15.1\_Transmission:0 A
- gnd-00R1-18 → 14.3\_Tacho\_Air\_Coolant:1 C
- gnd-00R1-18 → 3.1\_Main\_Dist:1 A
- gnd-00R1-18 → 1.1\_batteries:3 C
- gnd-00R2-10 → 7.1\_Mux\_Power:2 E
- gnd-00R2-12 → 7.1\_Mux\_Power:2 D
- gnd-00R3-12 → 7.1\_Mux\_Power:4 C
- gnd-00R3-12 → 7.1\_Mux\_Power:4 D

- gnd-00R4-12 → 7.1\_Mux\_Power:4 D
- gnd-00R4-12 → 7.1\_Mux\_Power:4 E
- gnd-00R4-16 → 7.1\_Mux\_Power:3 C
- gnd-00R5-14 → 14.2\_Urea:1 B
- gnd-00R5-12 → 14.1\_Engine\_Ecu:3 C
- gnd-00R5-14 → 1.1\_batteries:0 B

### REAR SEAT

- gnd-00S-10 → 40.2\_DCDC\_12V:3 C
- gnd-00S-10 → 40.2\_DCDC\_12V:4 C

Rr Seat  
Electronic GND

# Electronic ground distribution

### AE56

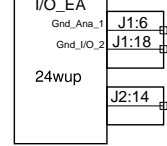

### AE41

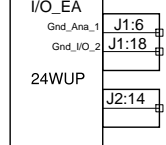

### AE44

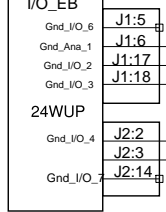

### AE42

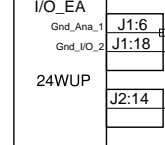

### AE45

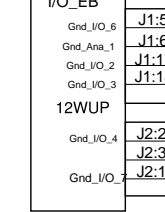

### AE46

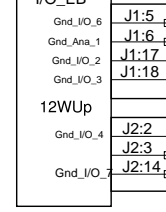

### AE43

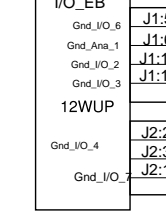

### RH console JB

### AE47

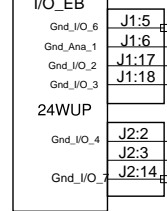

### AE48

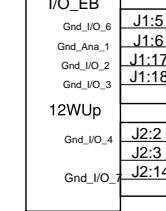

### Parcel Rack JB

### AE53

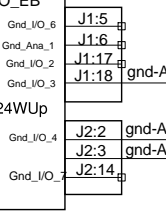

### Evaporator

### AE54

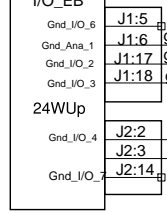

### WCL

### AE57

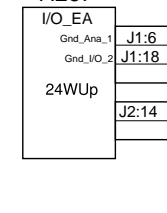

### RJB

### AE49

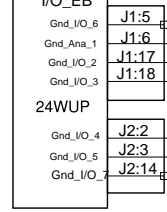

### AE50

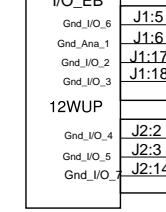

### AE51

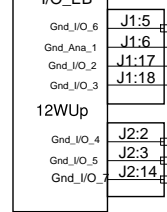

### AE52

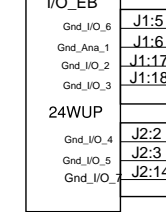

**\*\*Ground distribution:\*\***

0-Electric gnd  
00- Electronic Gnd

A-Dash - Lh console harness  
F-Front junction box harness  
FH-Front harness  
R-Rear junction box harness  
FR-Front to rear

# Chassis ground distribution

## Front GND stud

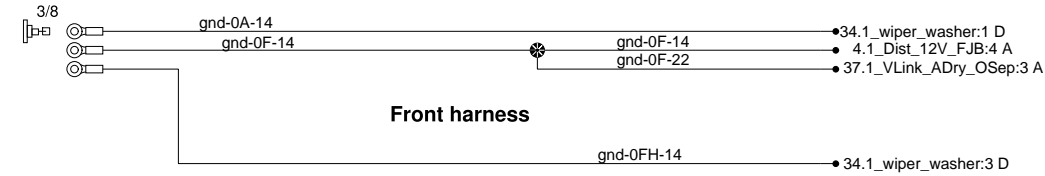

## Dash harness

## Front harness

## Fuel tank ground stud

## Condensor cmpt. stud



## RJB stud

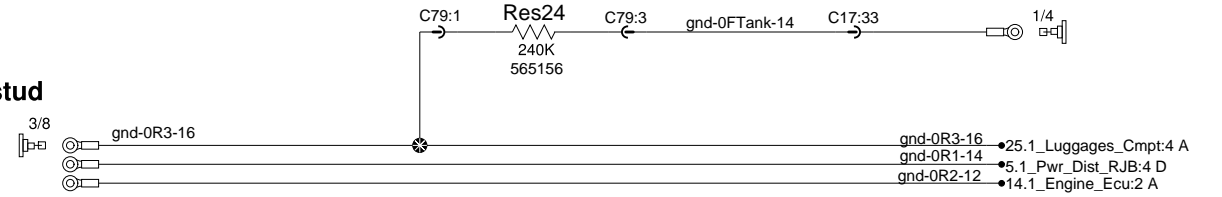

## Evaporator cmpt. stud

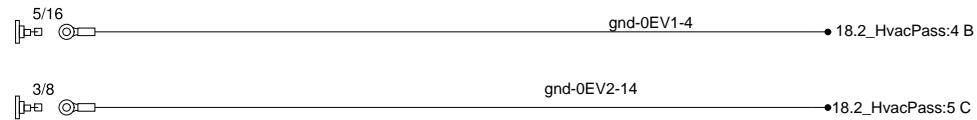

## RJB Stud AFSS GND

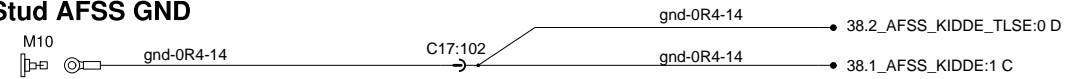

## Urea cmpt. stud

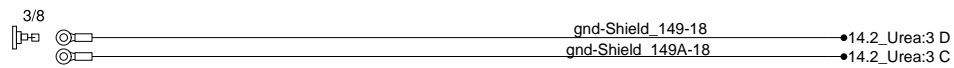

## Front radiator stud



## Radiator door stud

## Located on the top of the luggage compartment

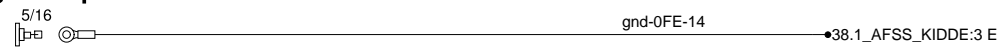

## Rear radiator stud



## Luggage chassis stud



## Engine cmpt. studs

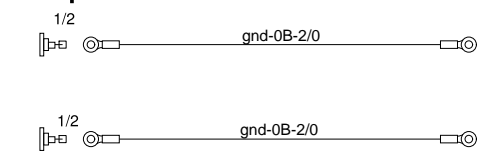

## Engine studs

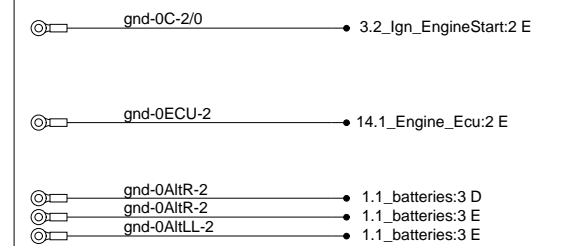

# Main distribution batteries & ignition

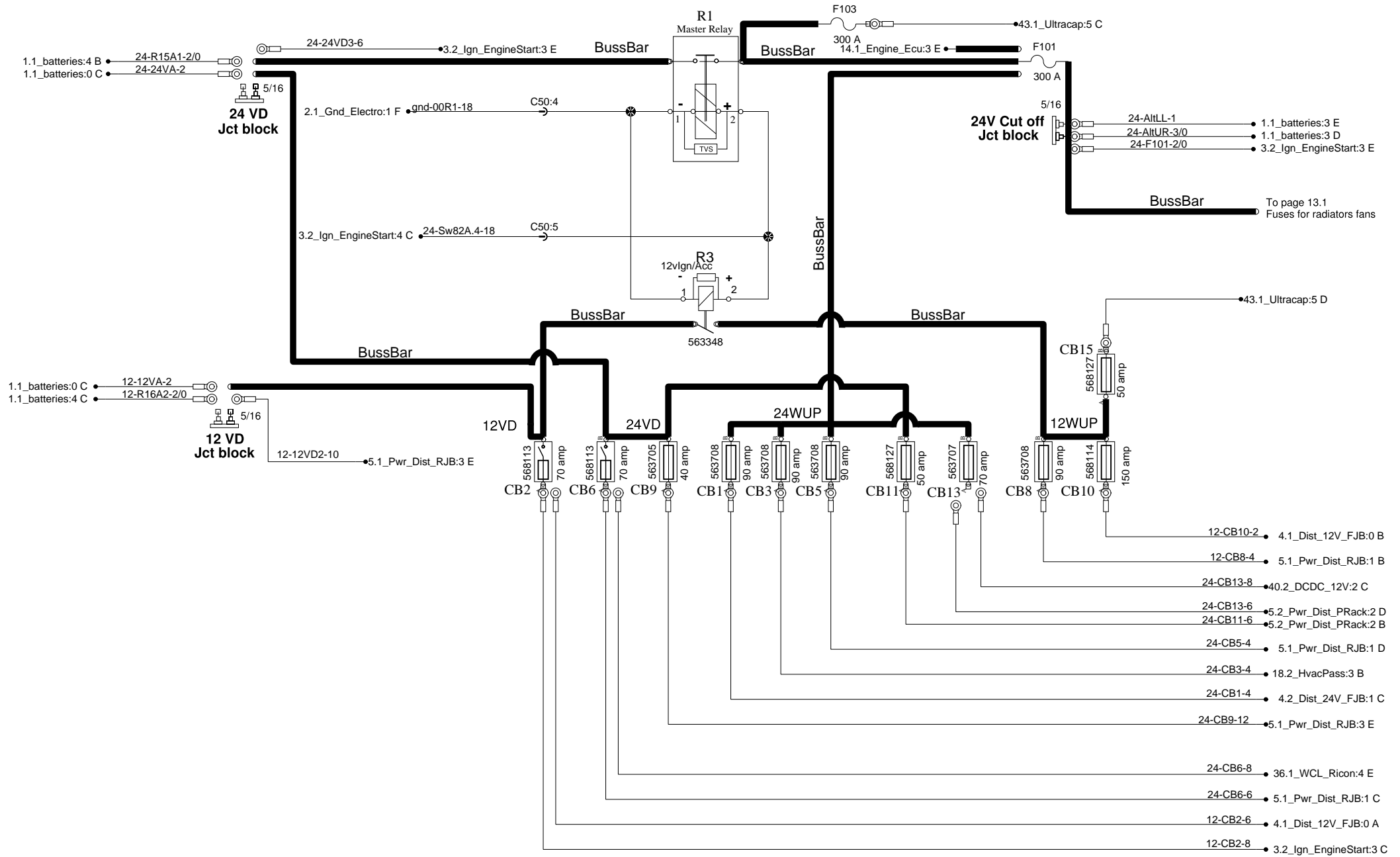

# Ignition and engine start

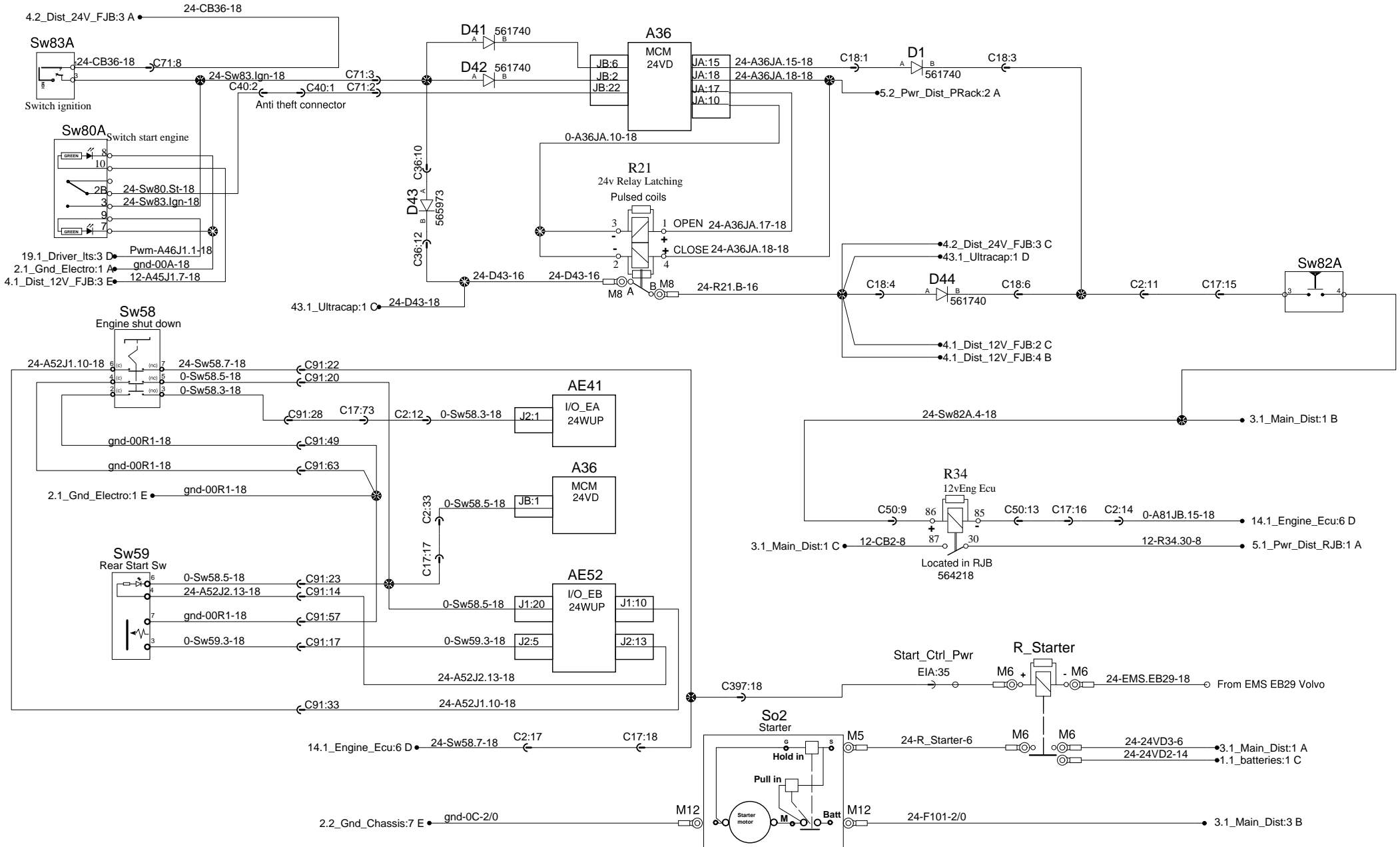

# Ignition and engine start

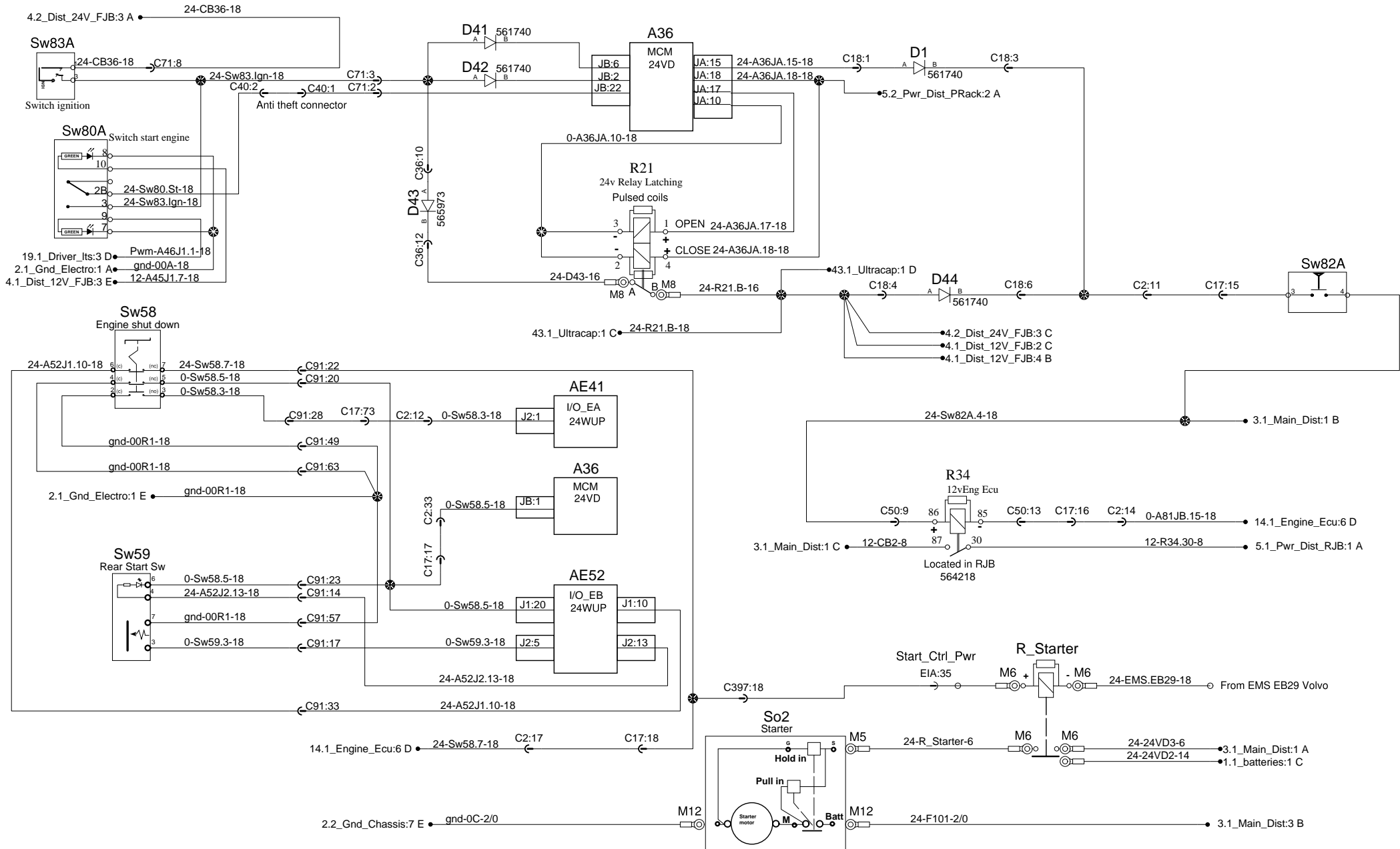

# Ignition and engine start

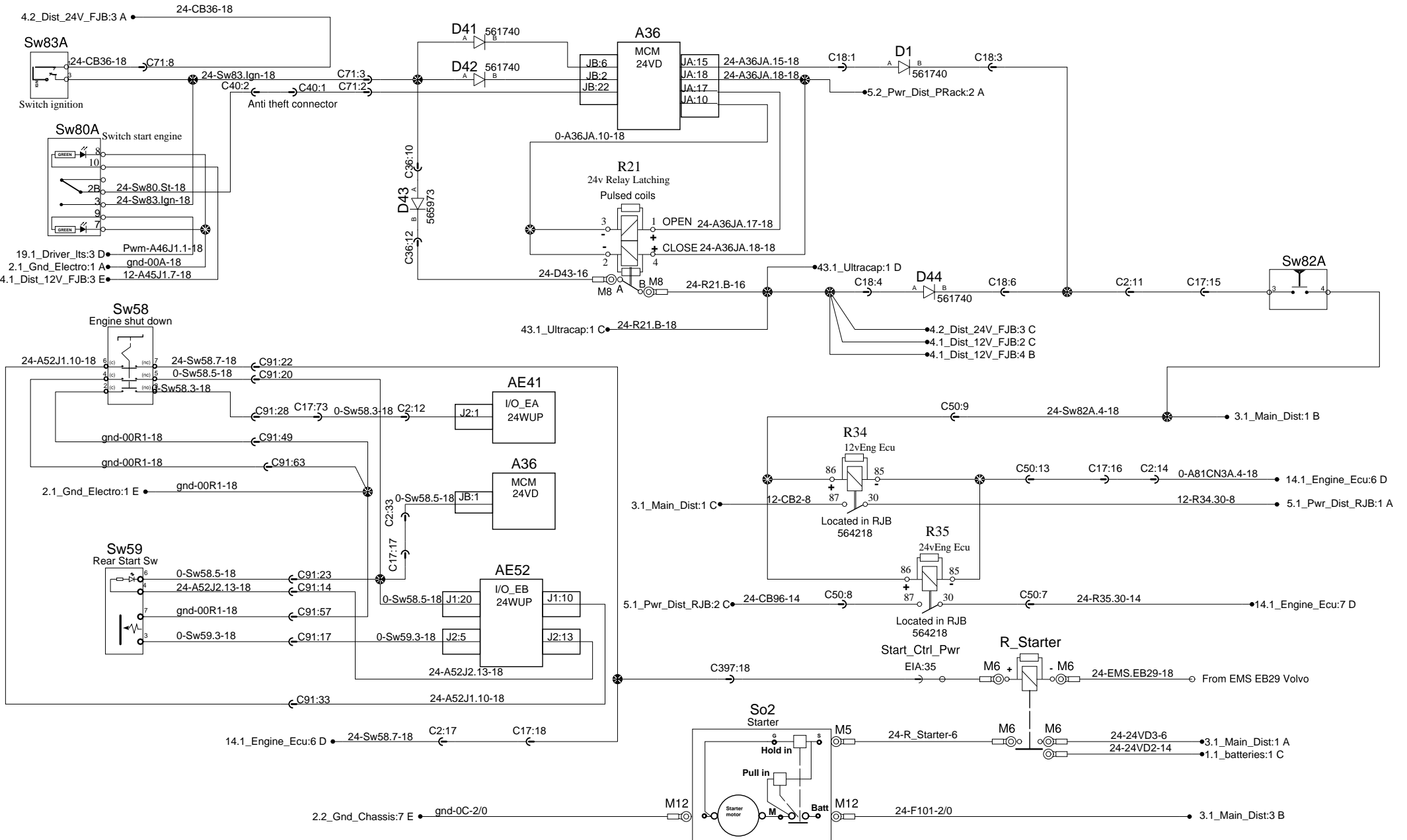

# 12V Power distribution front junction box

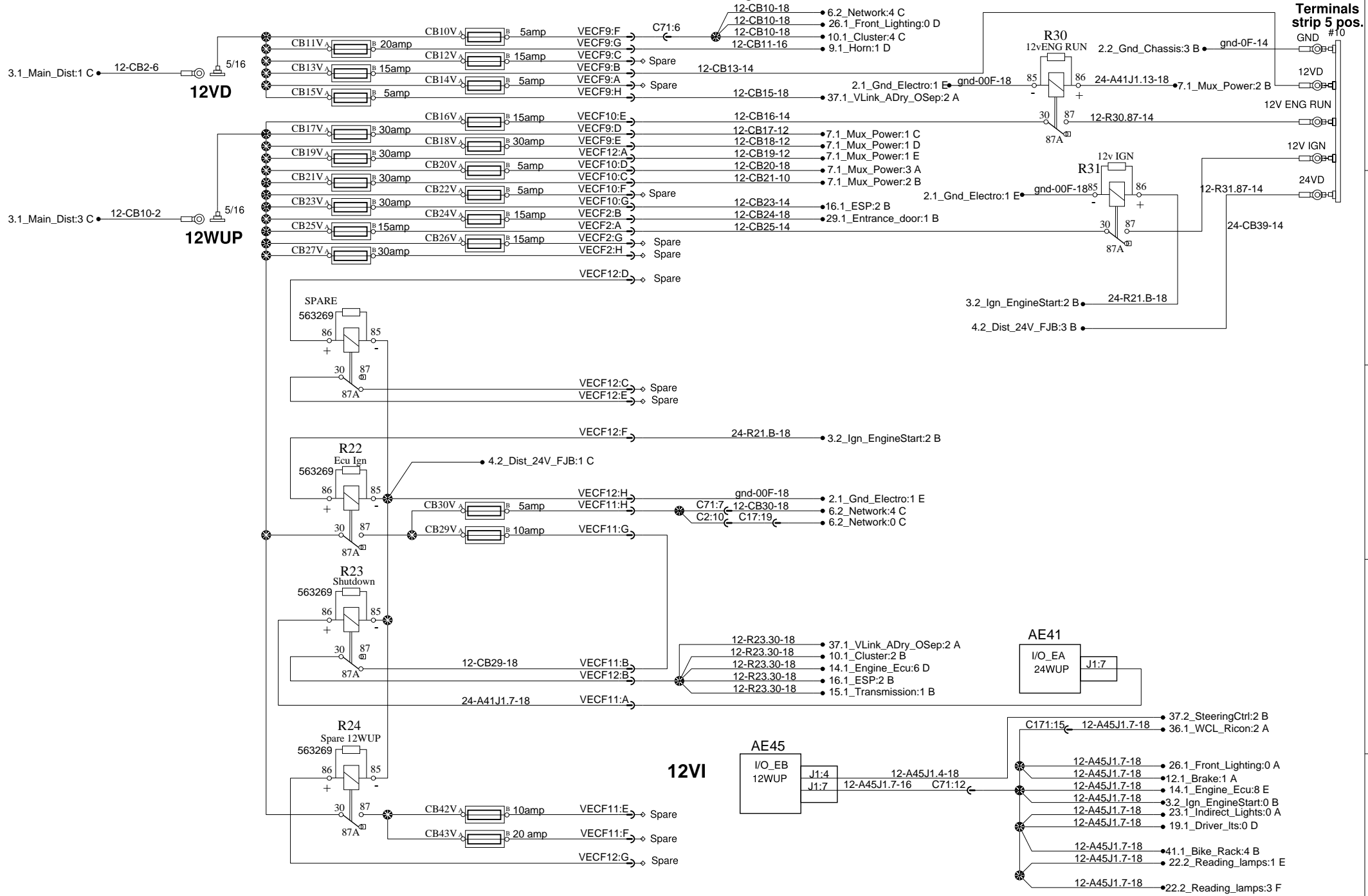

# 12V Power distribution front junction box

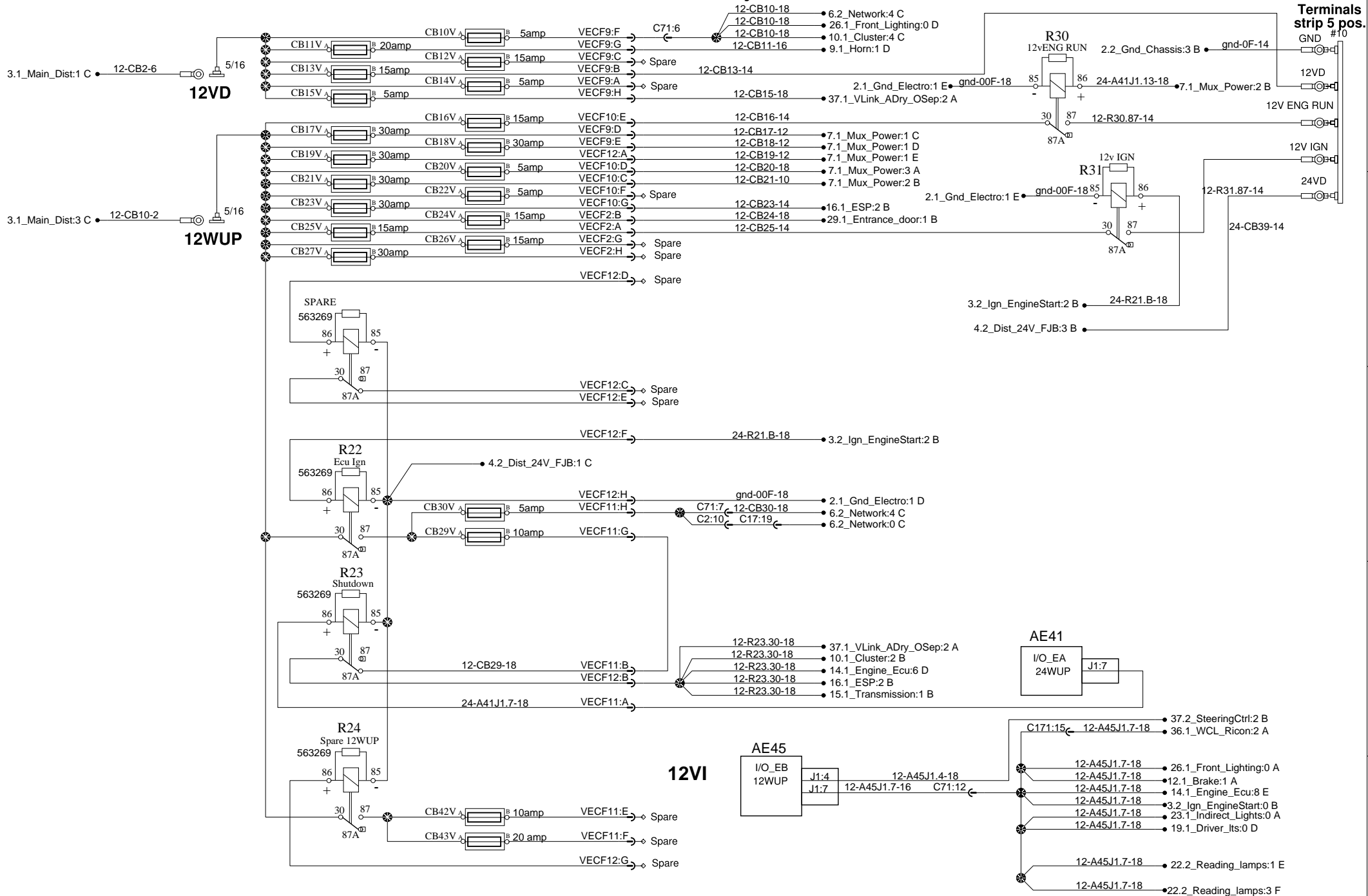



# 12V Power distribution front junction box

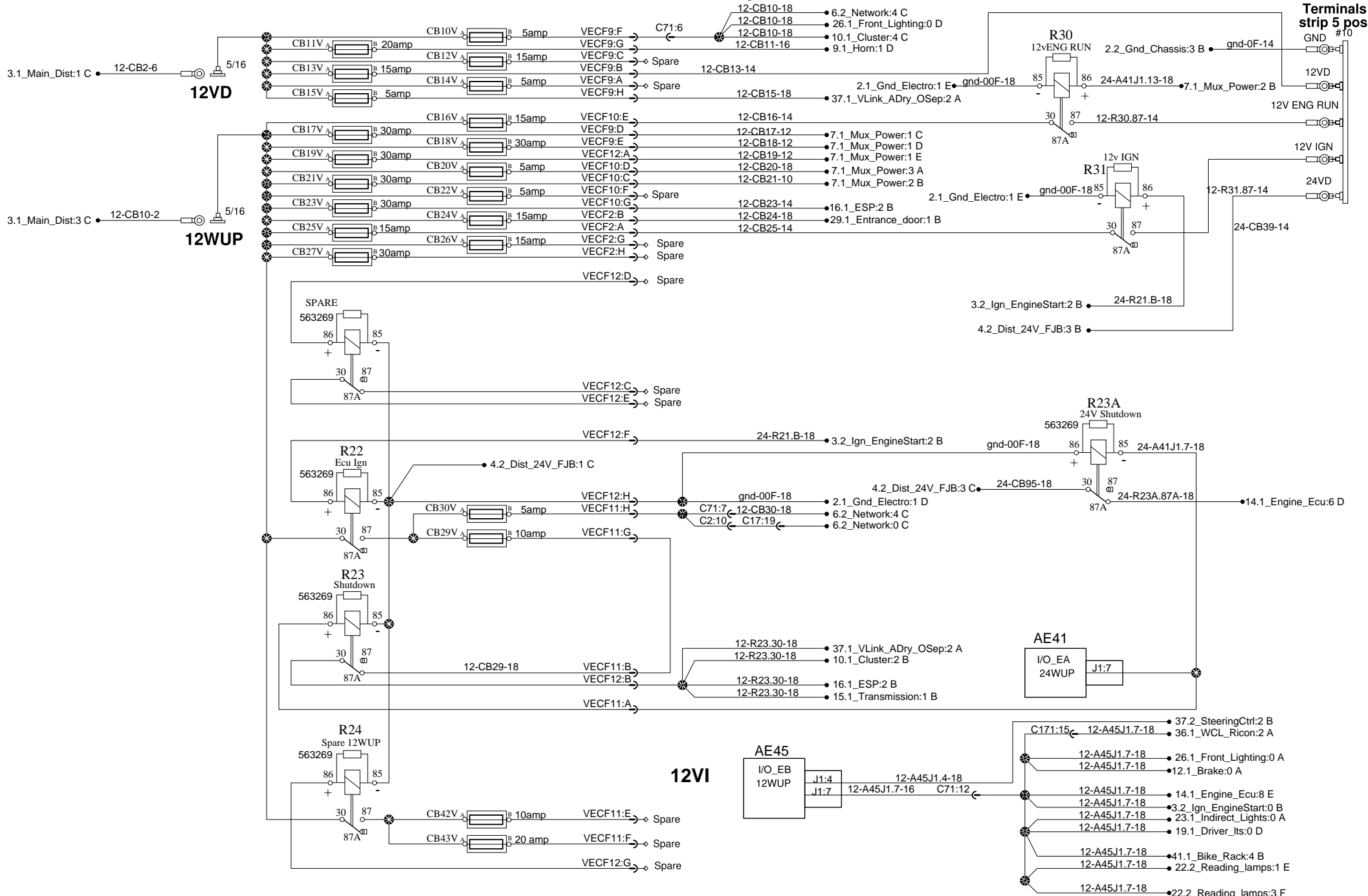

# 12V Power distribution front junction box

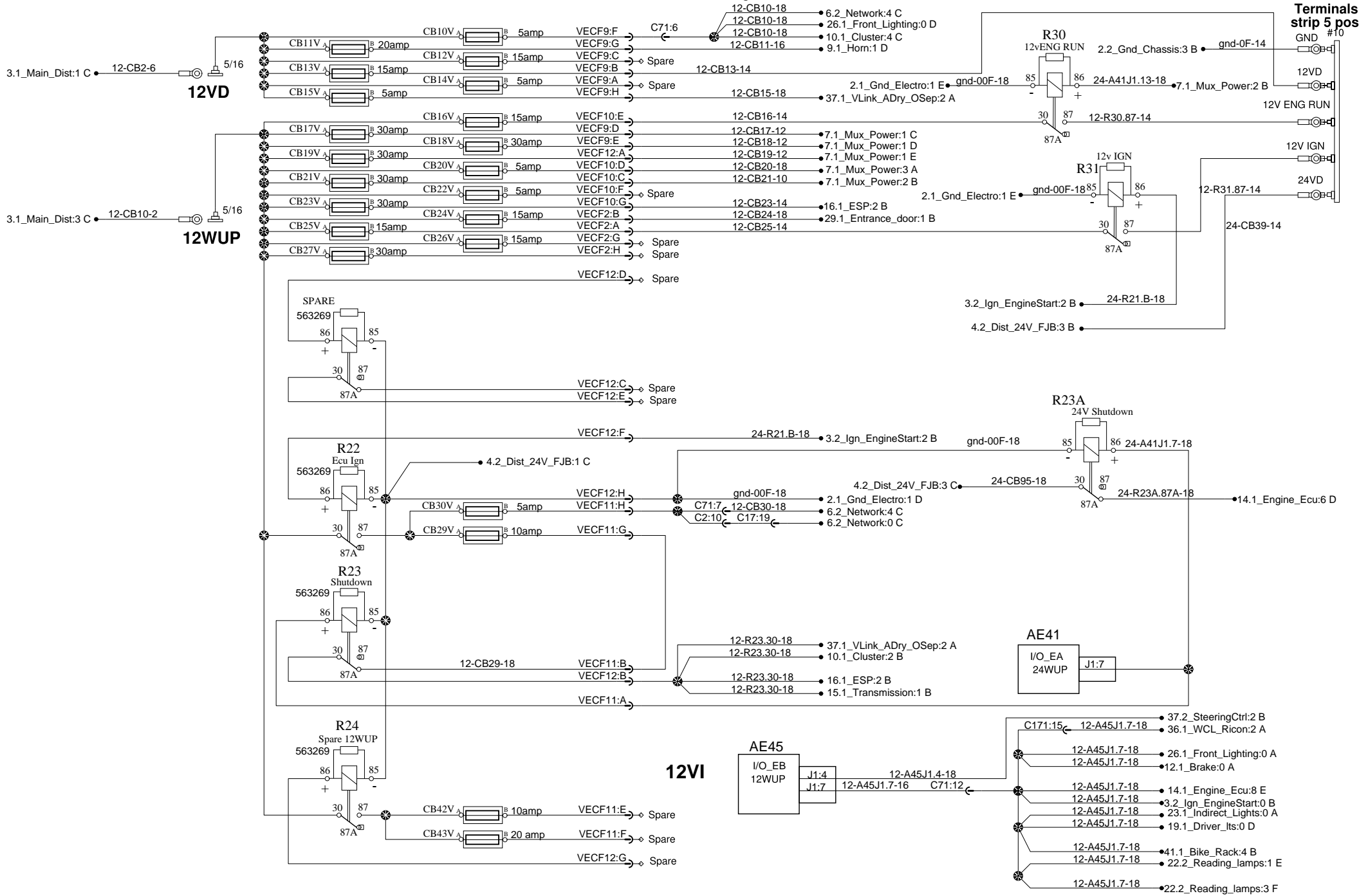

**Terminals strip 5 pos.**

- GND #10
- 12VD
- 12V ENG RUN
- 12V IGN
- 24VD

# 24V Power distribution front junction box

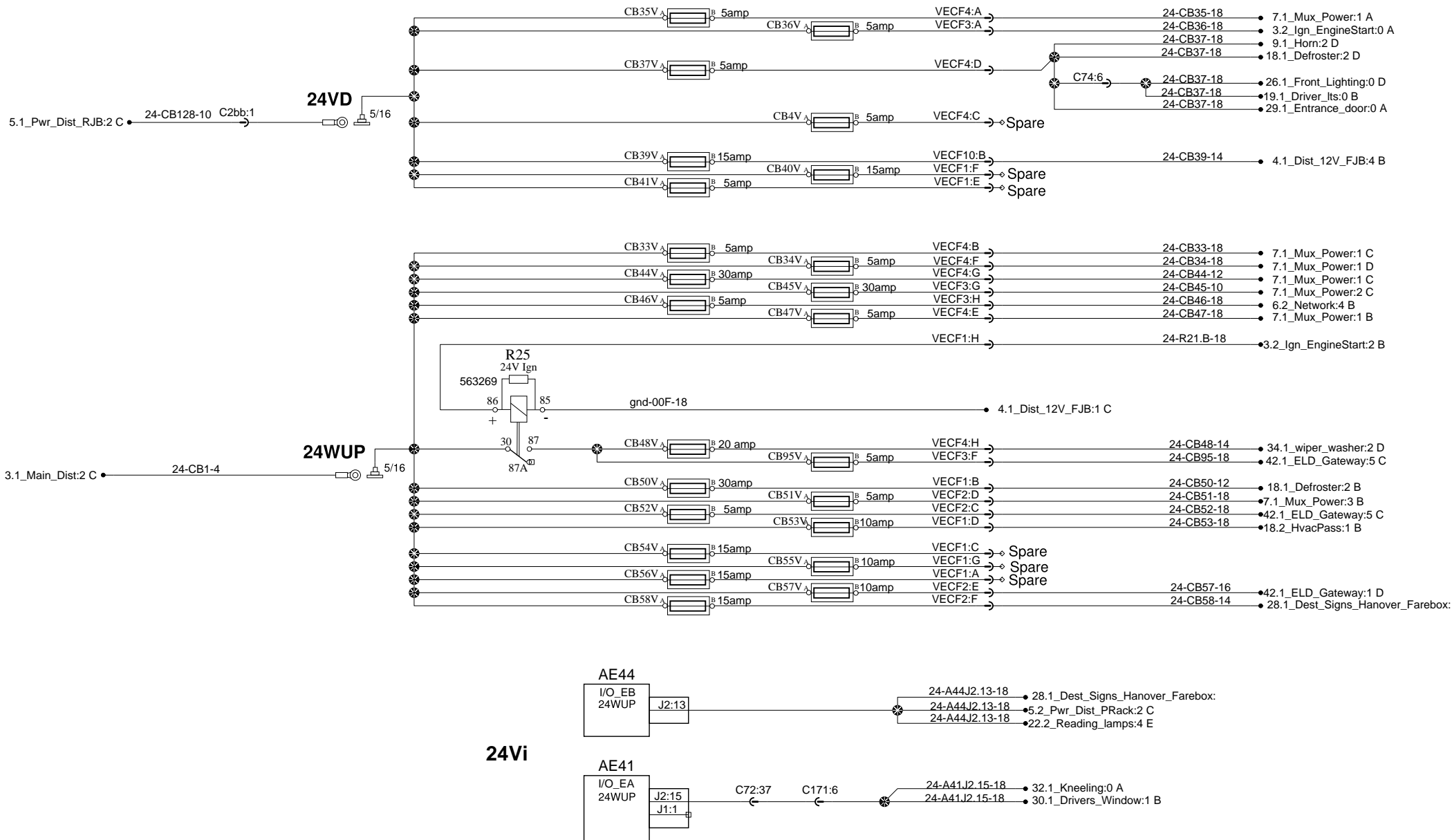

# 24V Power distribution front junction box

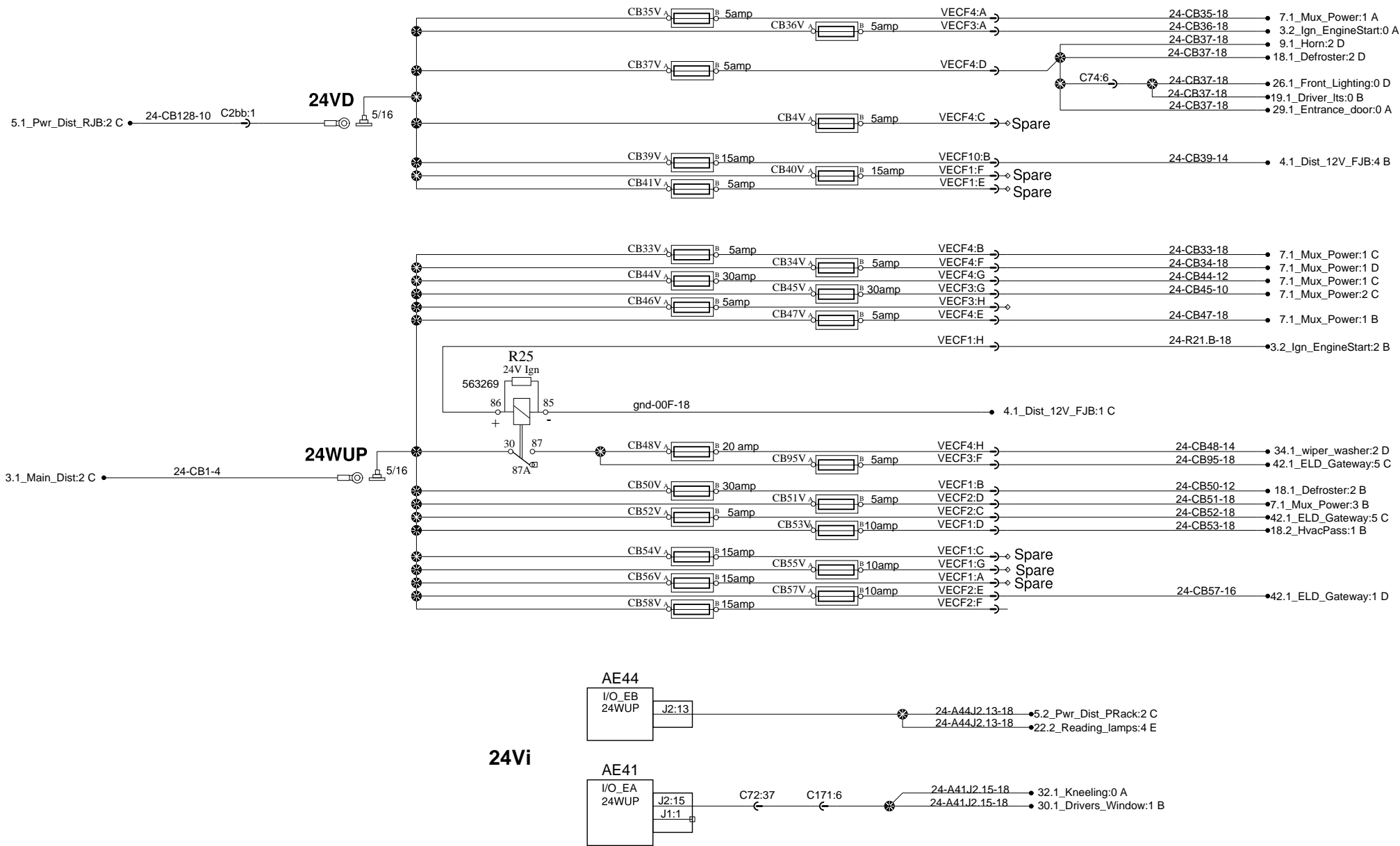

# 24V Power distribution front junction box

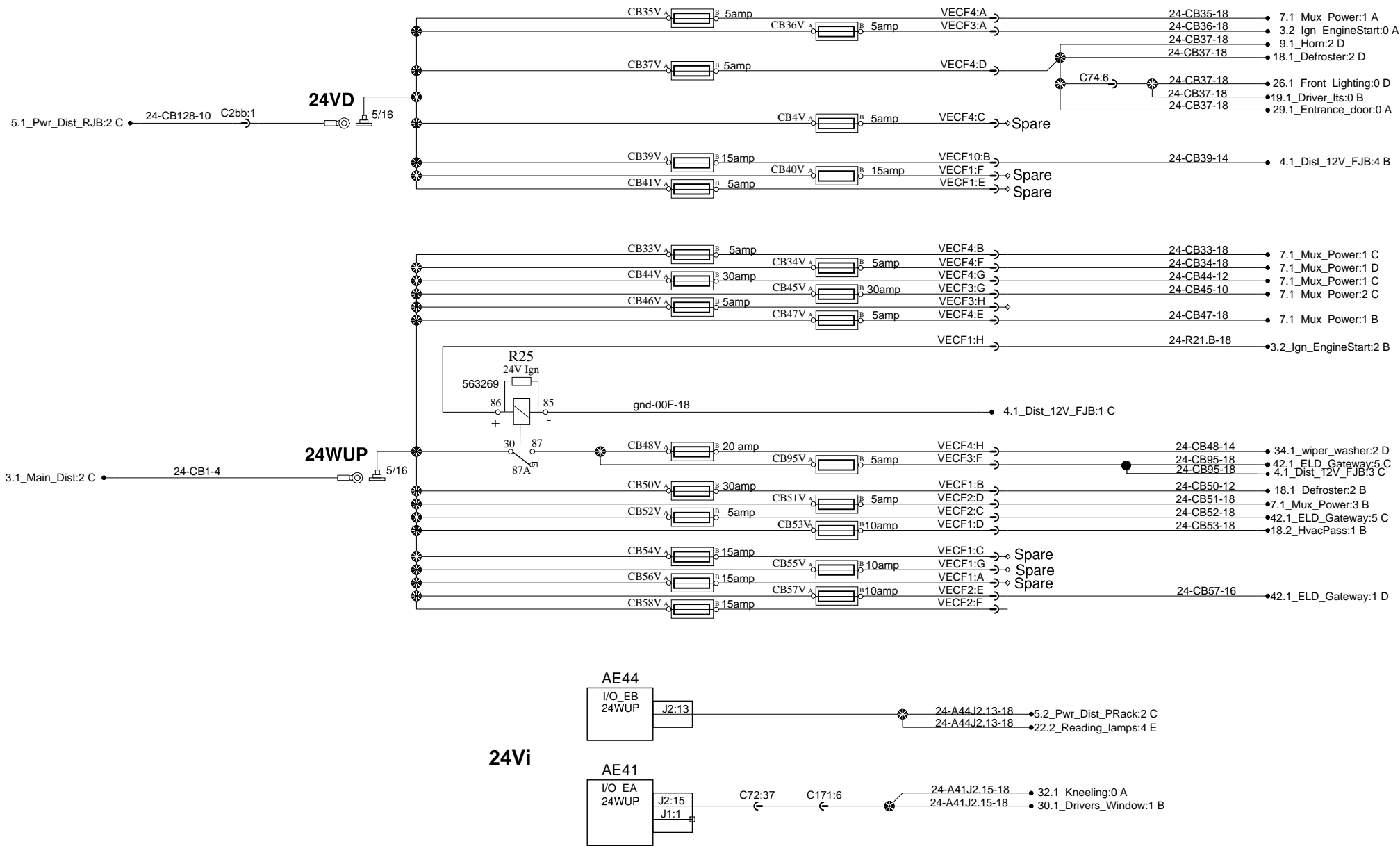

# 24V Power distribution front junction box

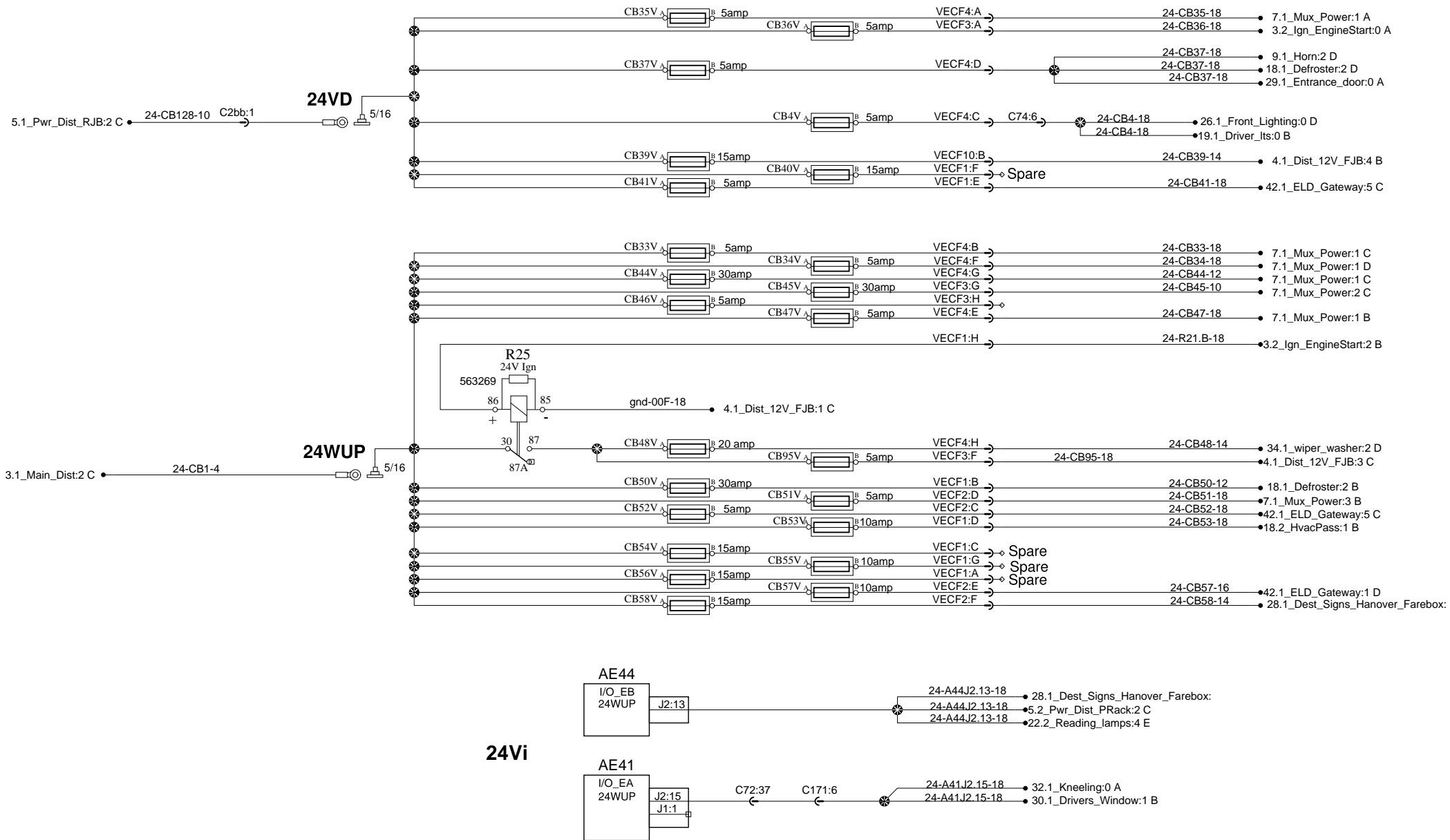

# Power distribution rear junction box

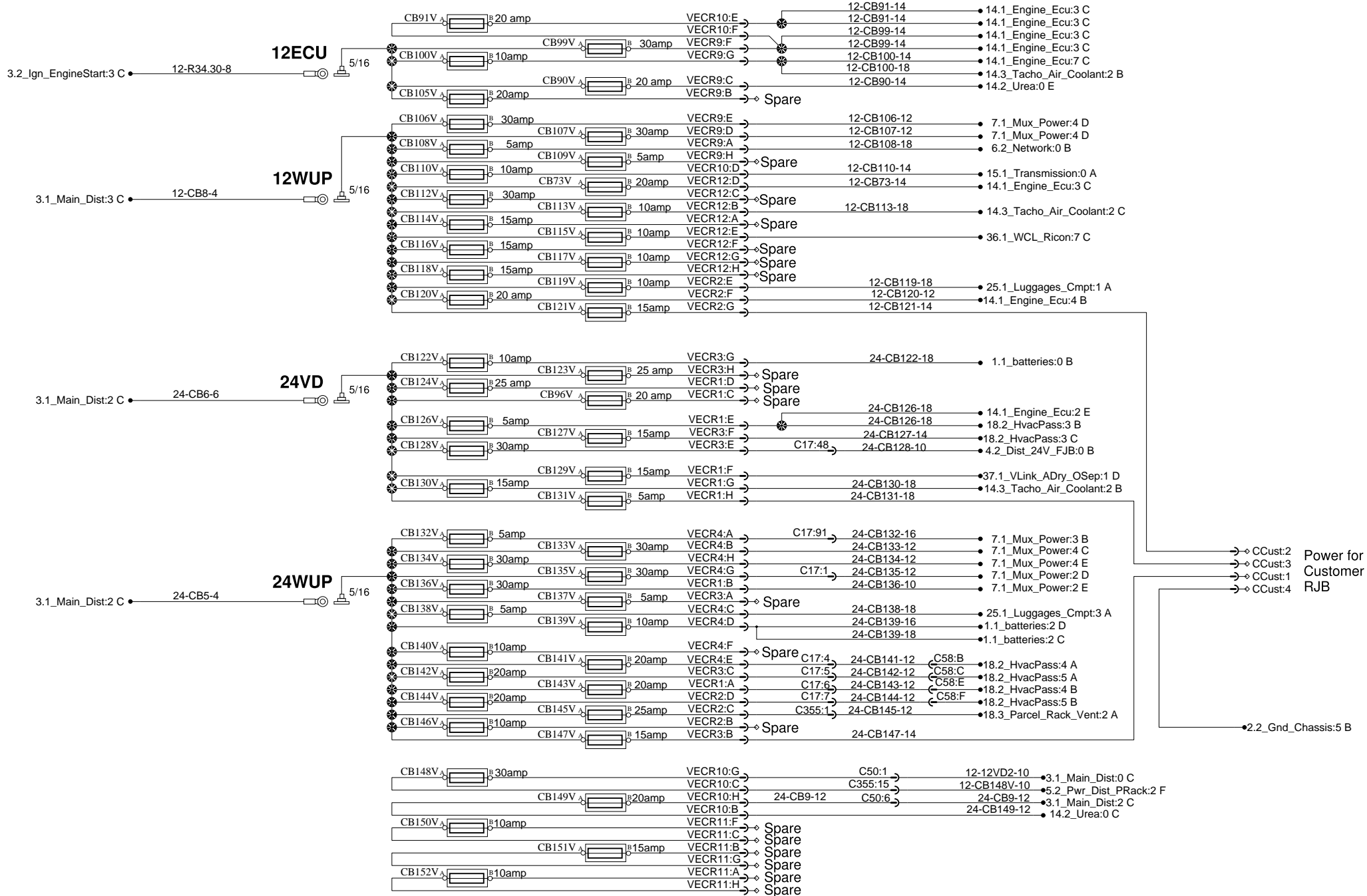

# Power distribution rear junction box

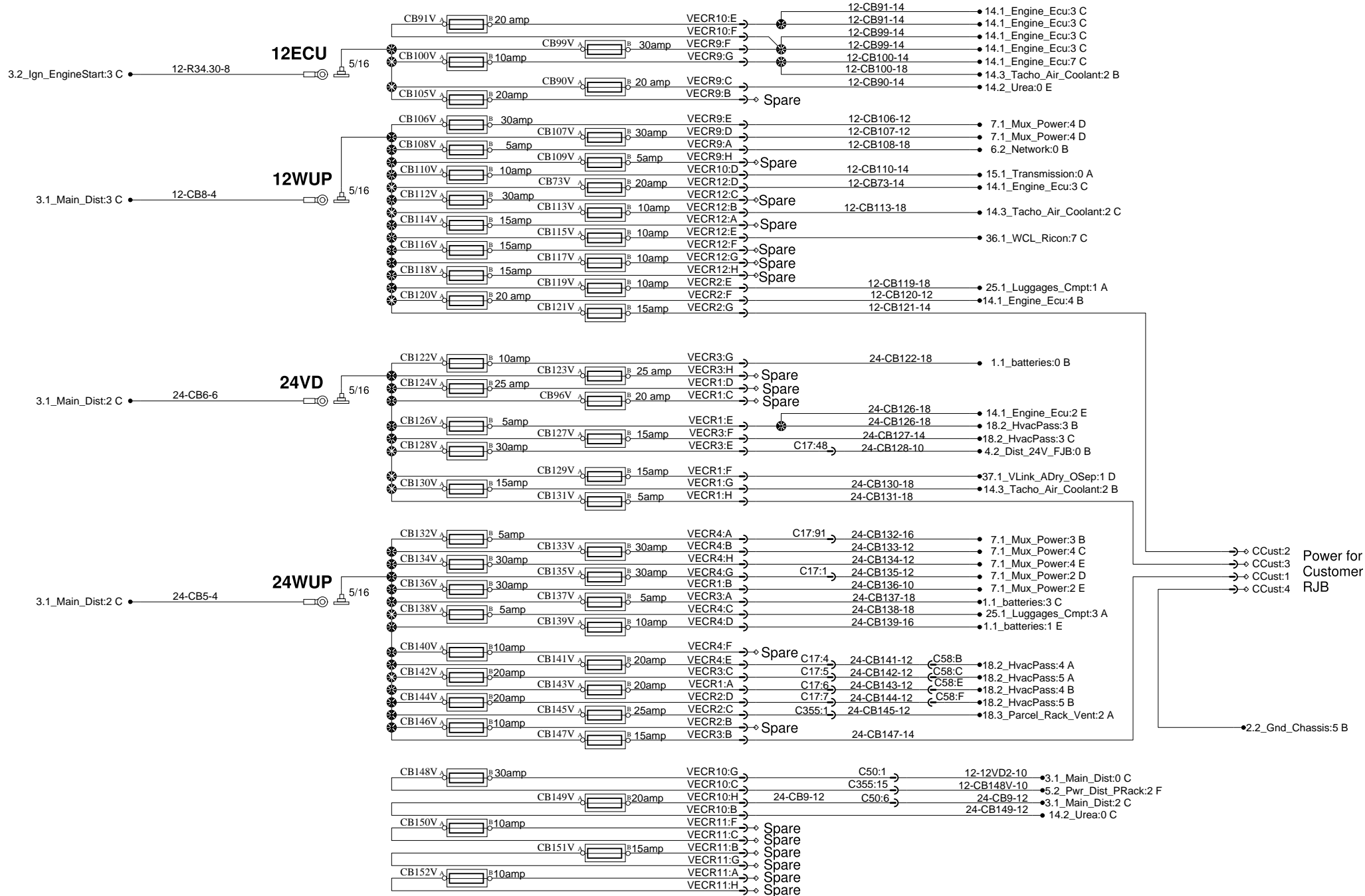



### Power distribution rear junction box

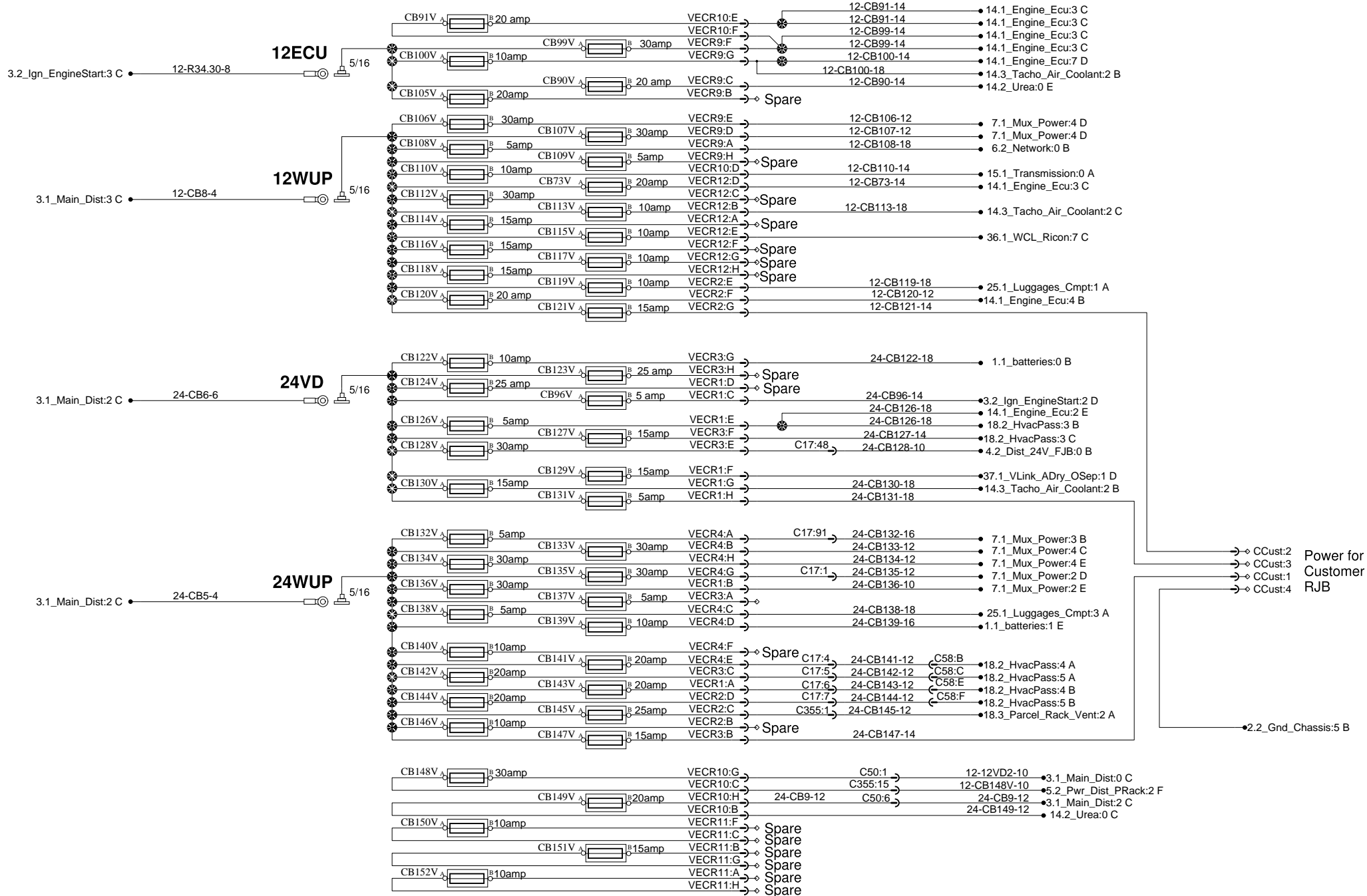

# Parcel Rack Power Distribution

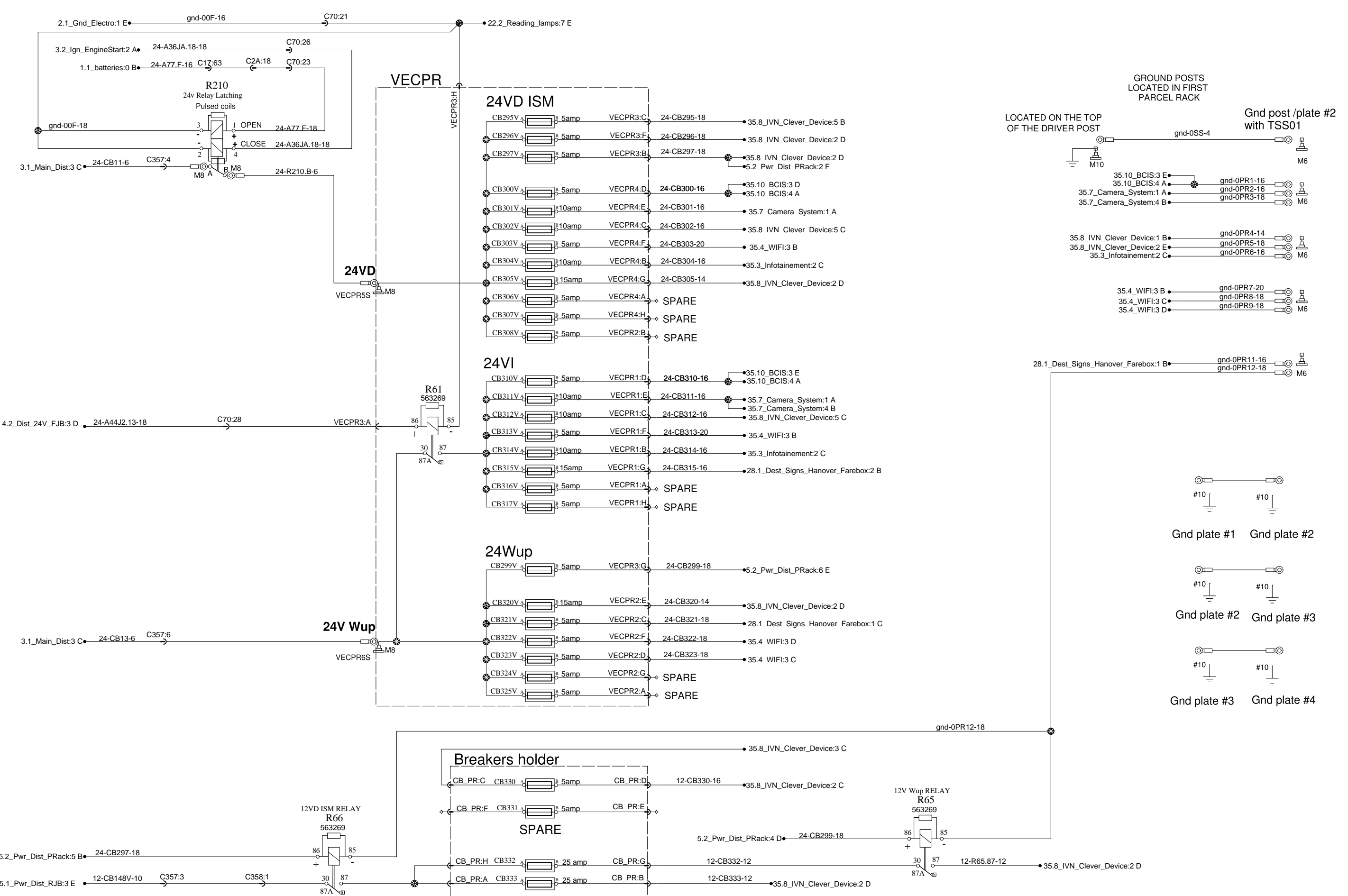

# Parcel Rack Power Distribution

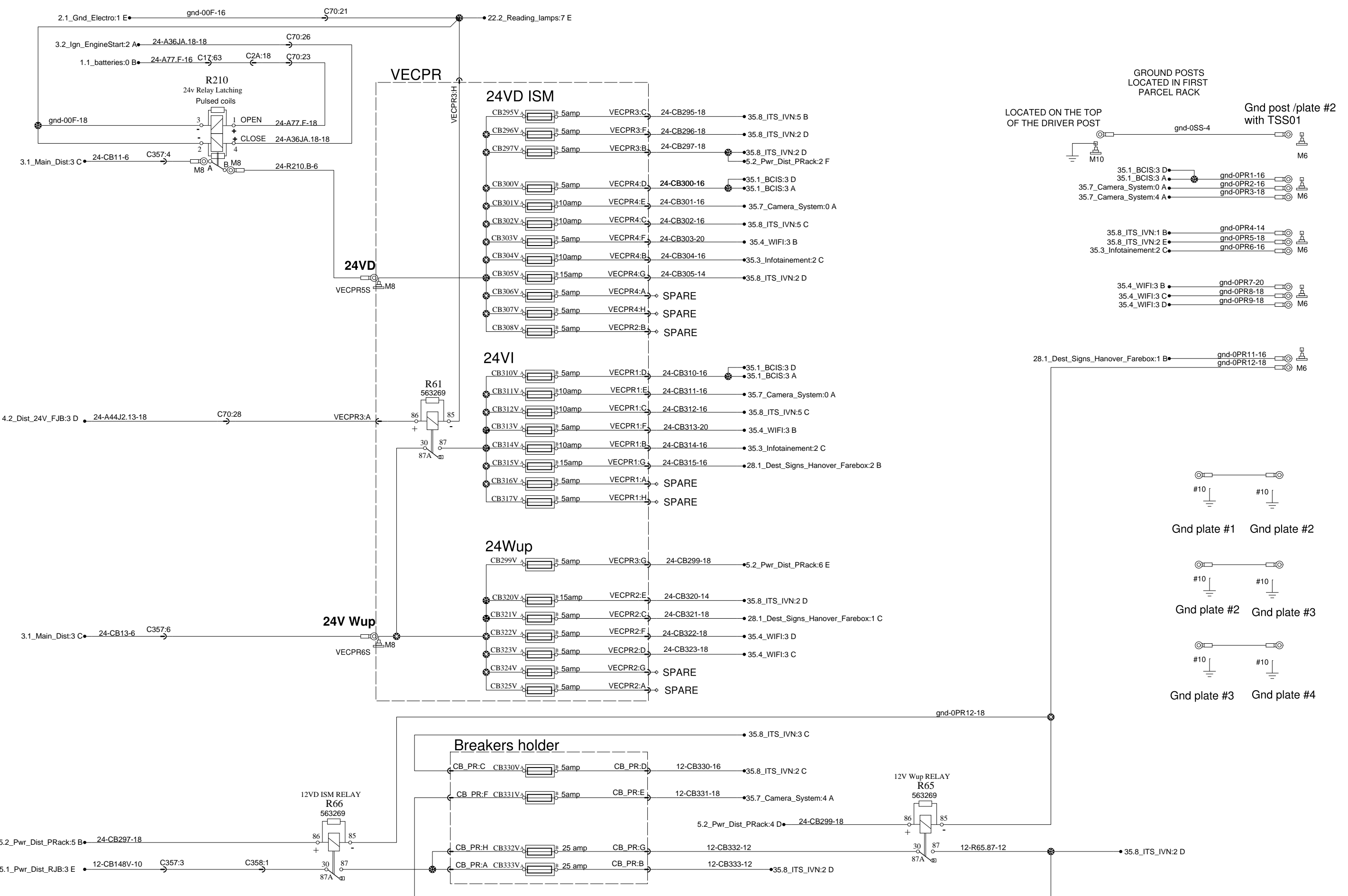

# Parcel Rack Power Distribution

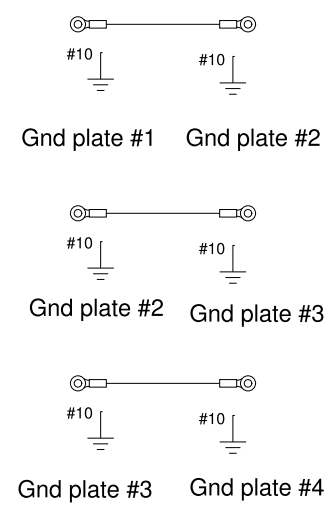
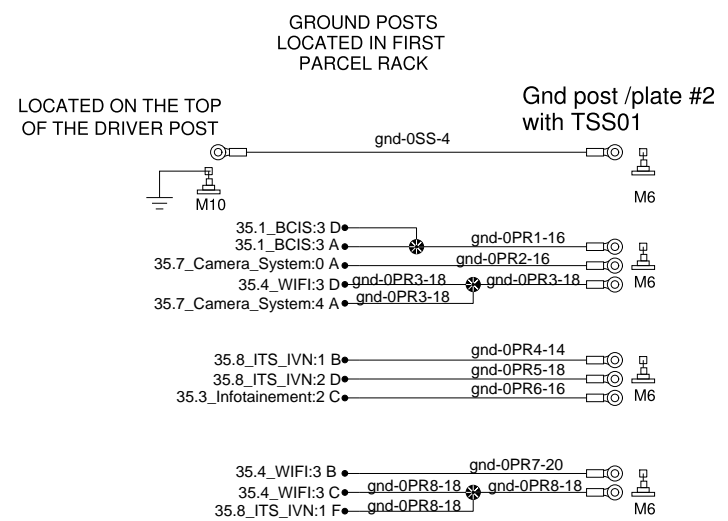
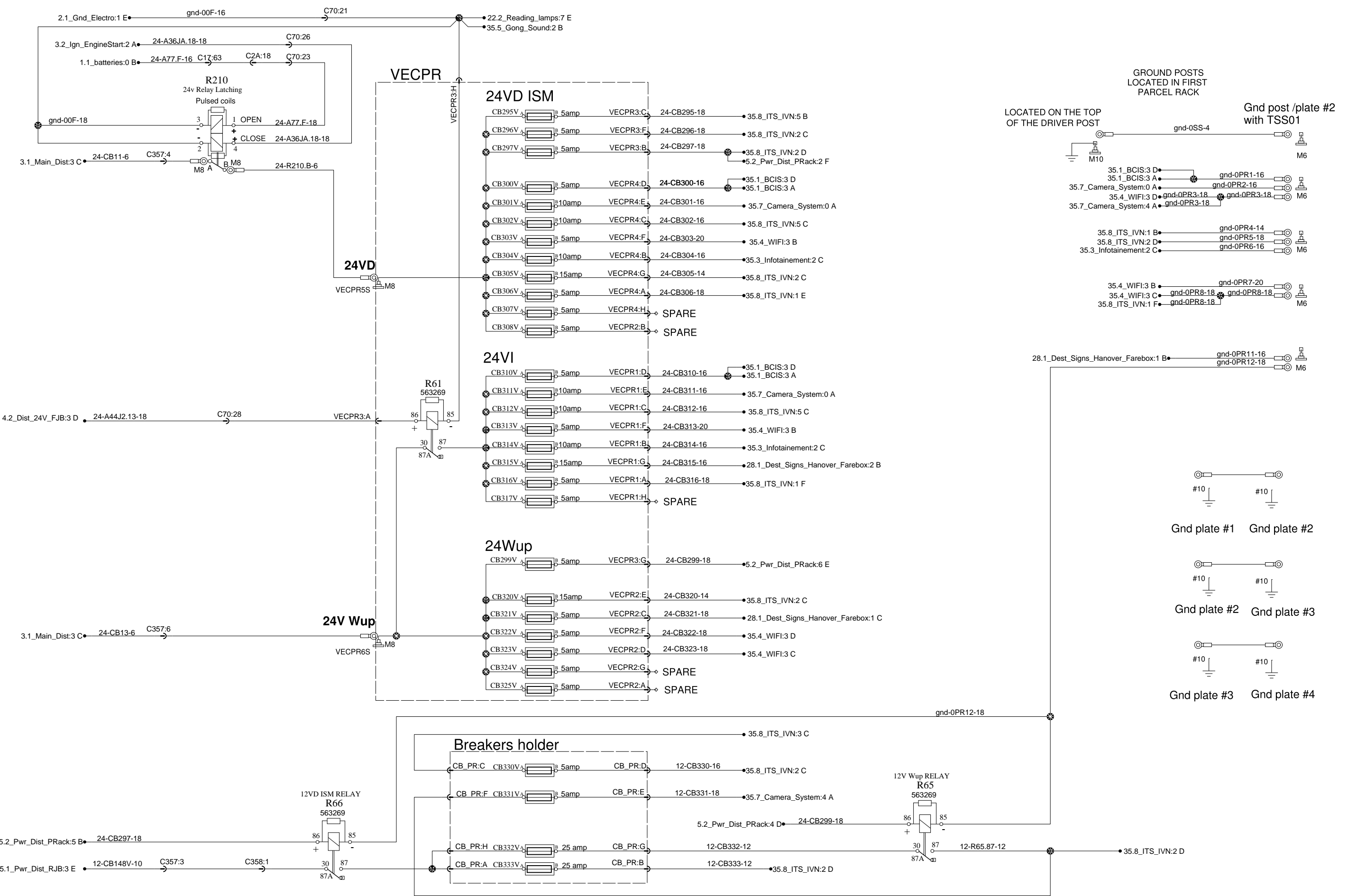

# Multiplex Can, J1587 Network and Addressing

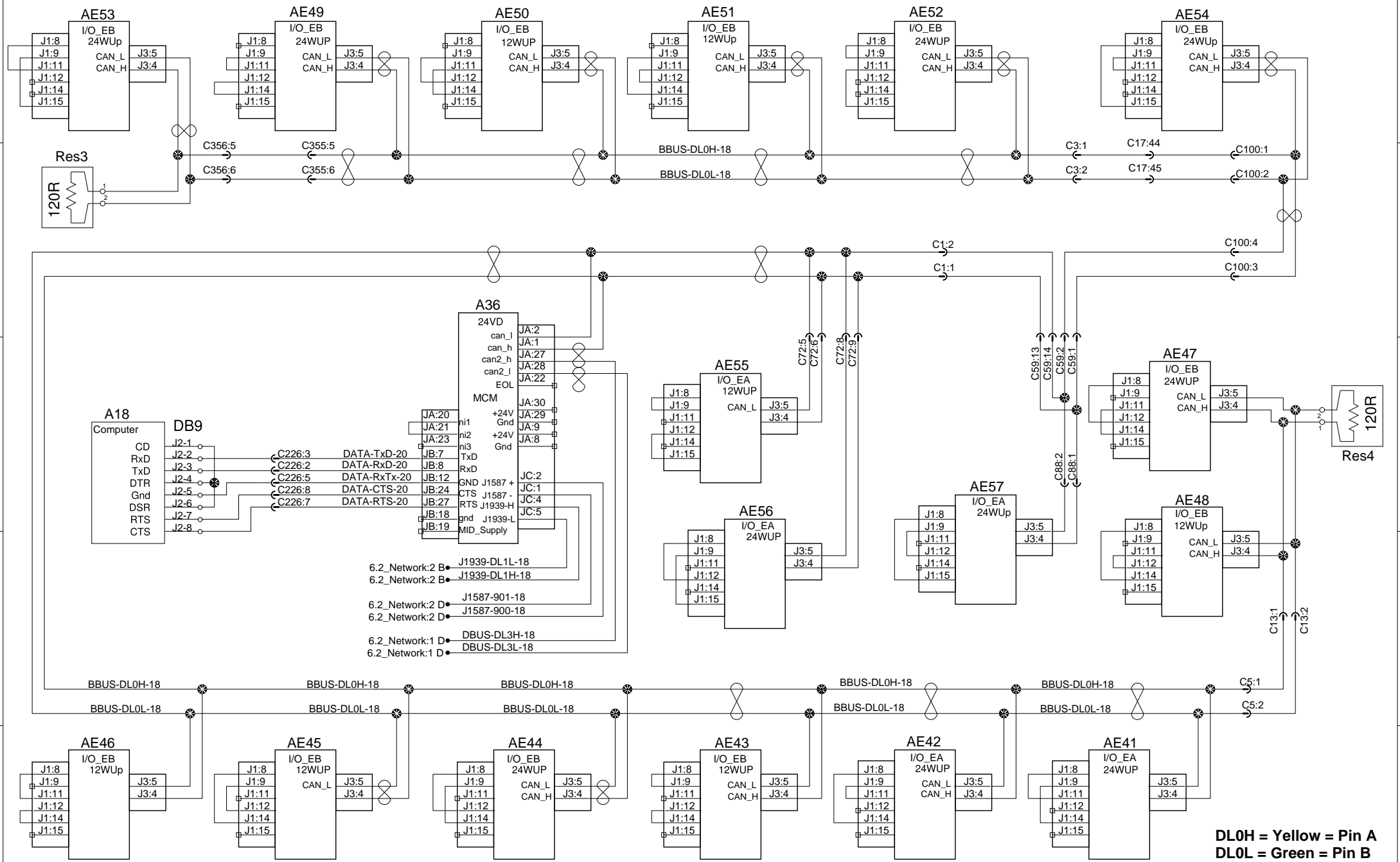

DL0H = Yellow = Pin A  
DL0L = Green = Pin B

# J1939, Can Iso, J1587 and DBUS

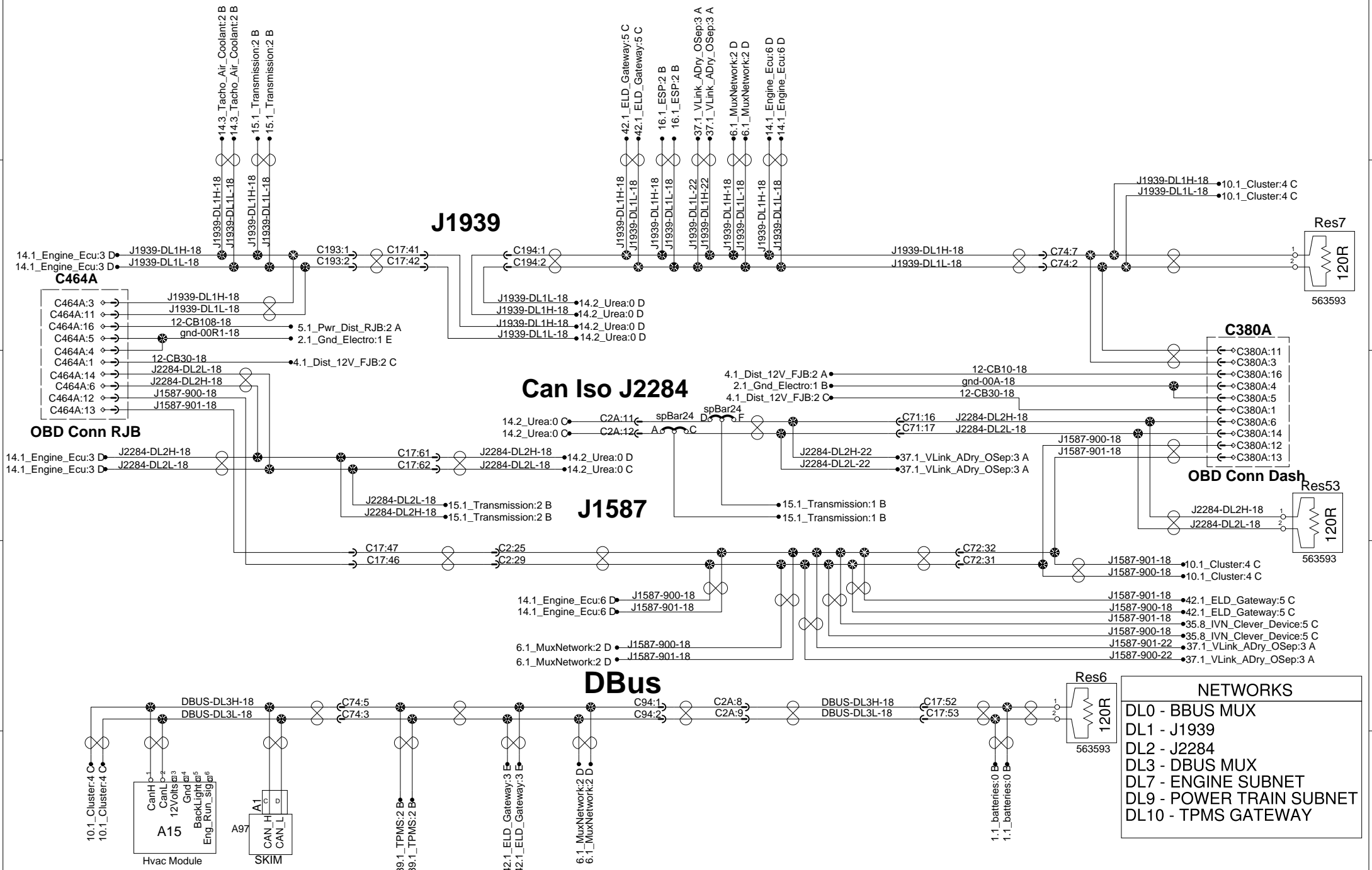

NETWORKS	
DL0	- BBUS MUX
DL1	- J1939
DL2	- J2284
DL3	- DBUS MUX
DL7	- ENGINE SUBNET
DL9	- POWER TRAIN SUBNET
DL10	- TPMS GATEWAY

# J1939, Can Iso, J1587 and DBUS

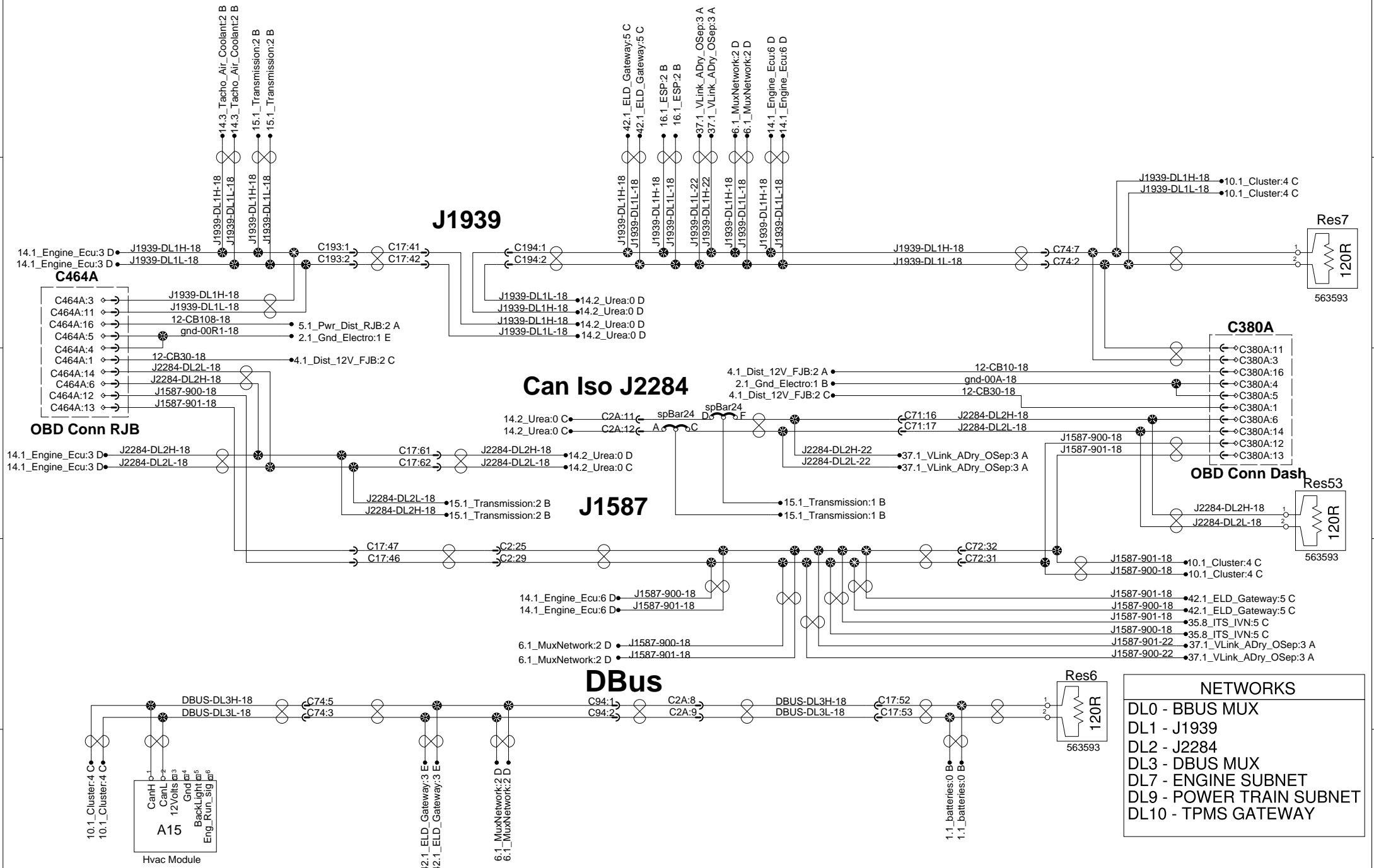

NETWORKS	
DL0	- BBUS MUX
DL1	- J1939
DL2	- J2284
DL3	- DBUS MUX
DL7	- ENGINE SUBNET
DL9	- POWER TRAIN SUBNET
DL10	- TPMS GATEWAY

# J1939, Can Iso, J1587 and DBUS

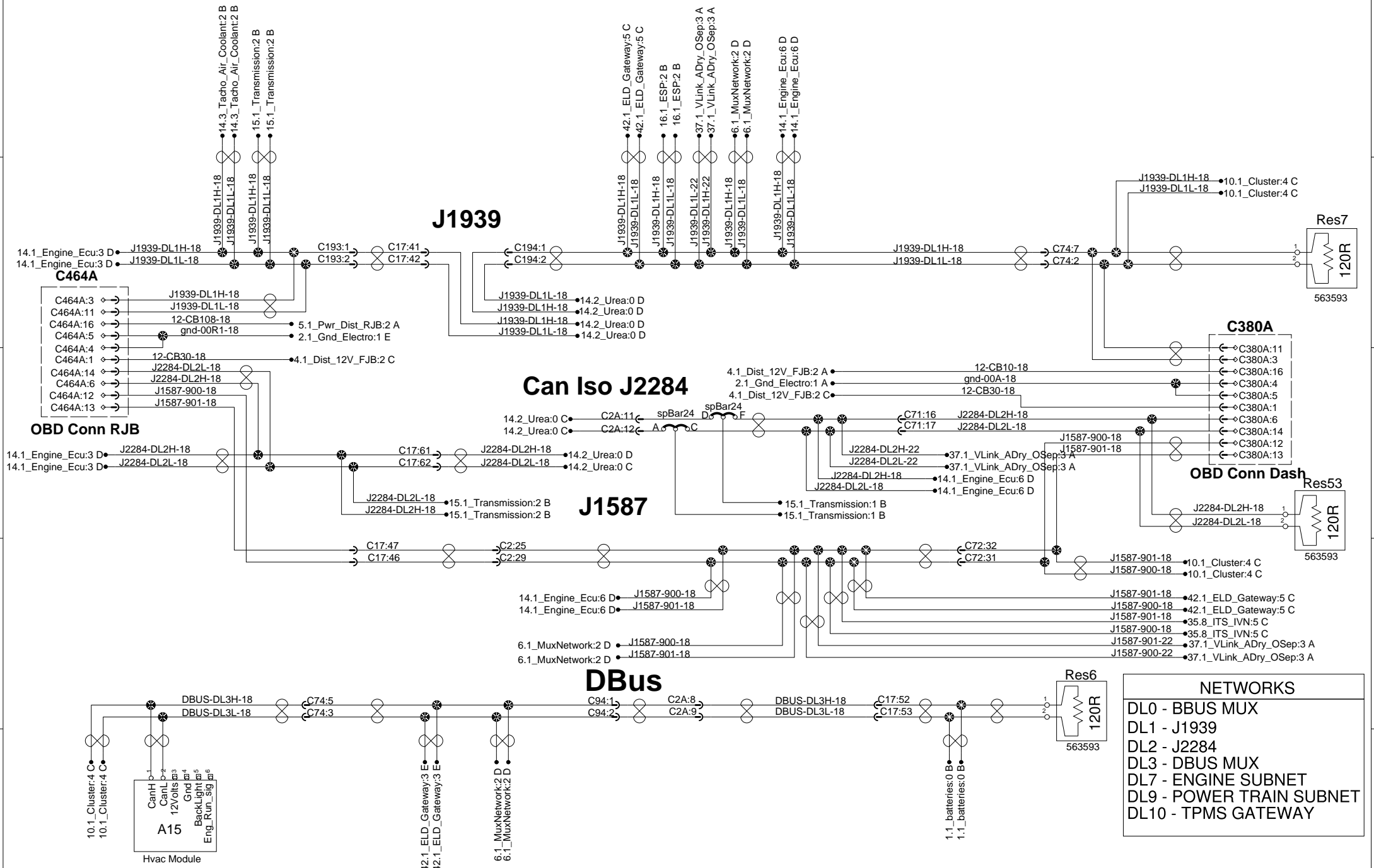

NETWORKS	
DL0	- BBUS MUX
DL1	- J1939
DL2	- J2284
DL3	- DBUS MUX
DL7	- ENGINE SUBNET
DL9	- POWER TRAIN SUBNET
DL10	- TPMS GATEWAY



### Front junction box

### Multiplex power supply distribution

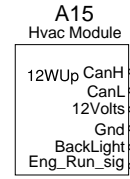
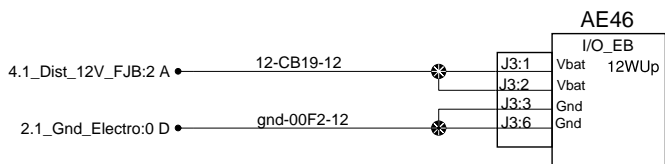
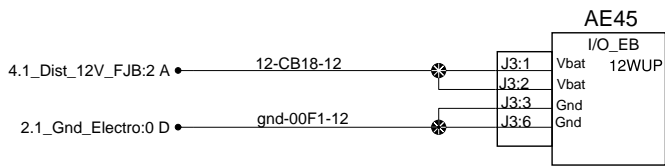
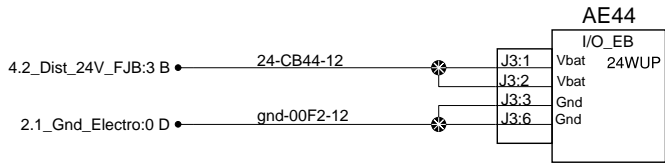
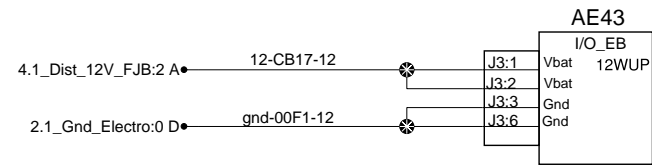
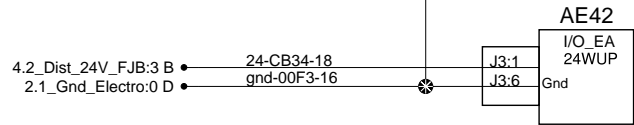
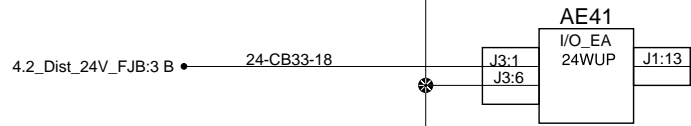
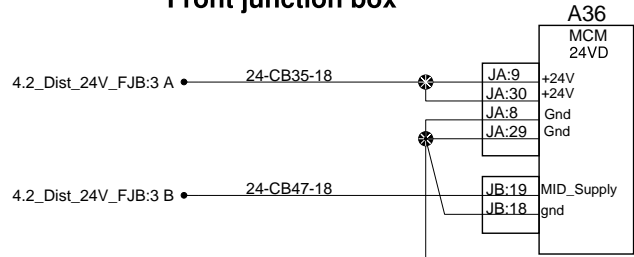

### Dash

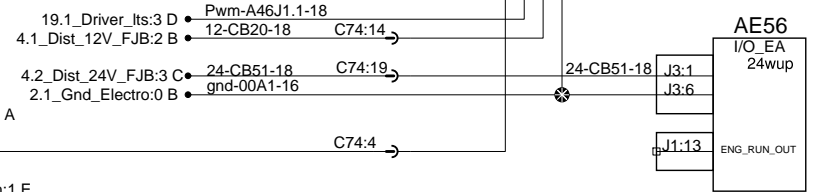

### RH Console

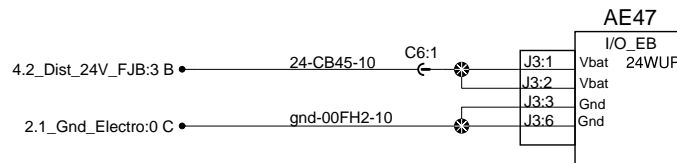
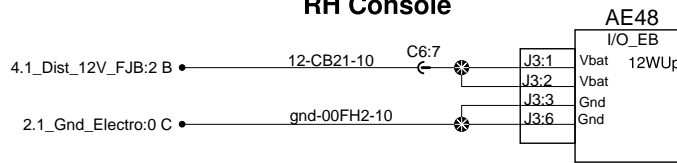

### Evaporator Cmpt.

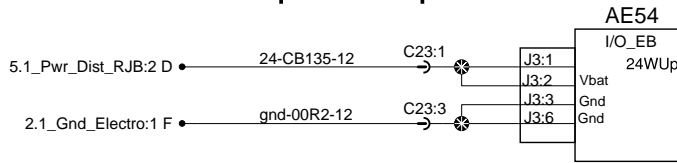

### Parcel rack junction box Rear left parcel rack

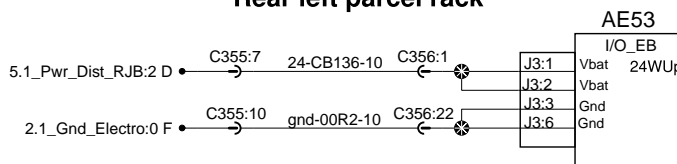

### WCL Cmpt.

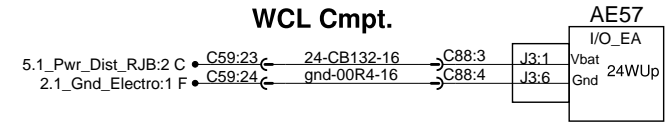

### Rear junction box

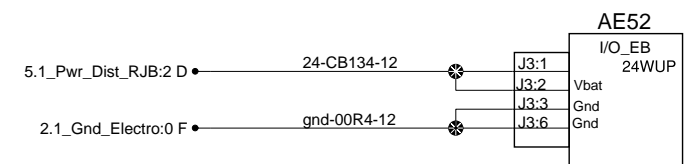
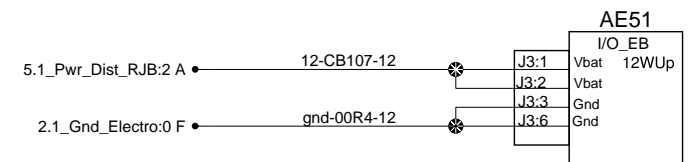
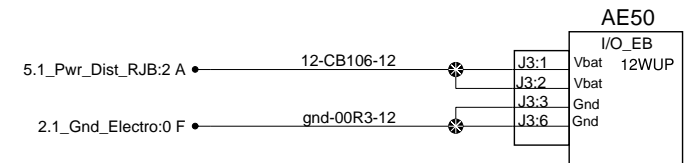
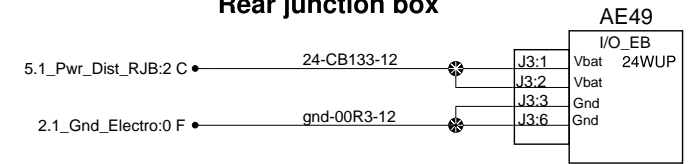

# Spare Wires

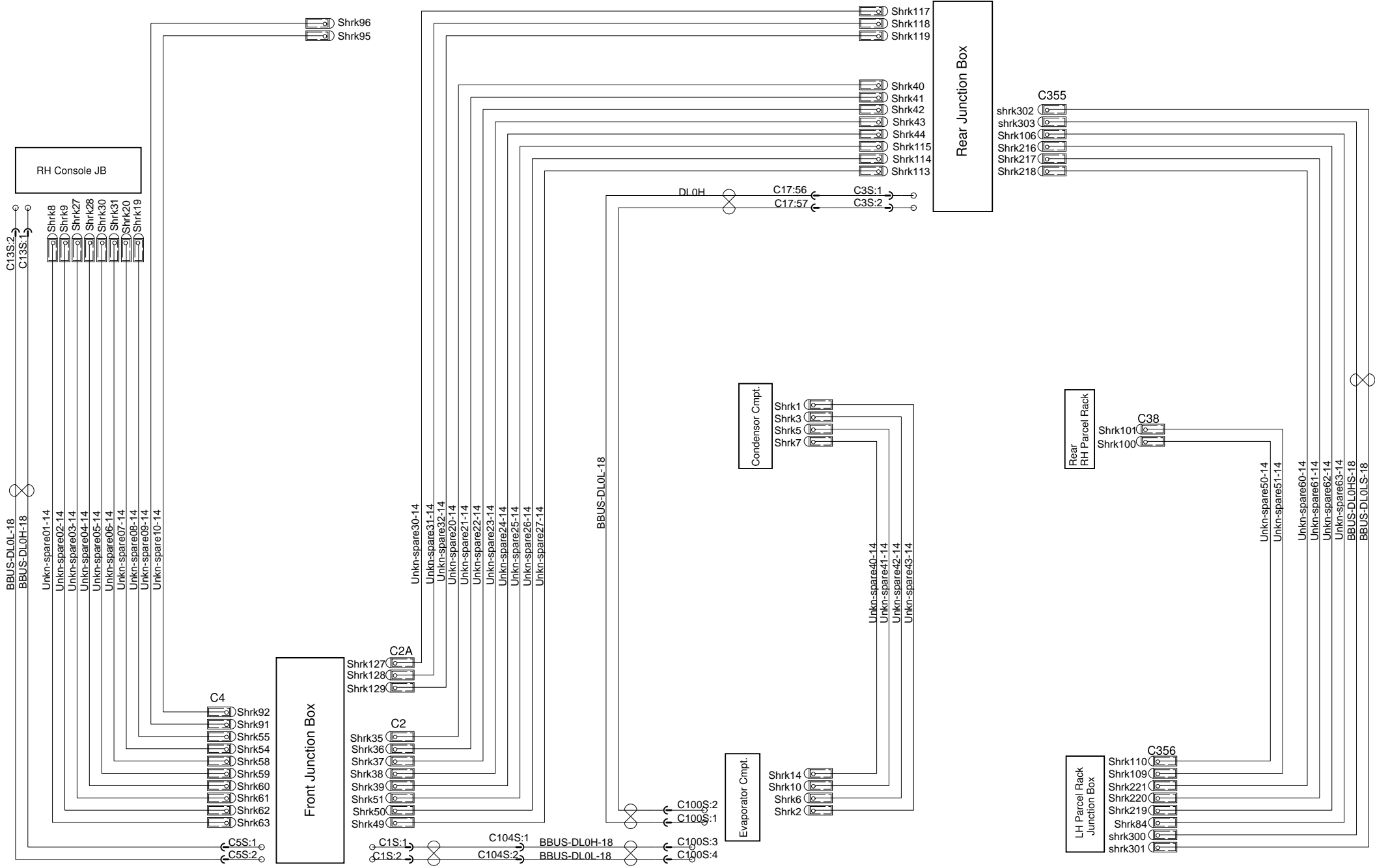

# Horn

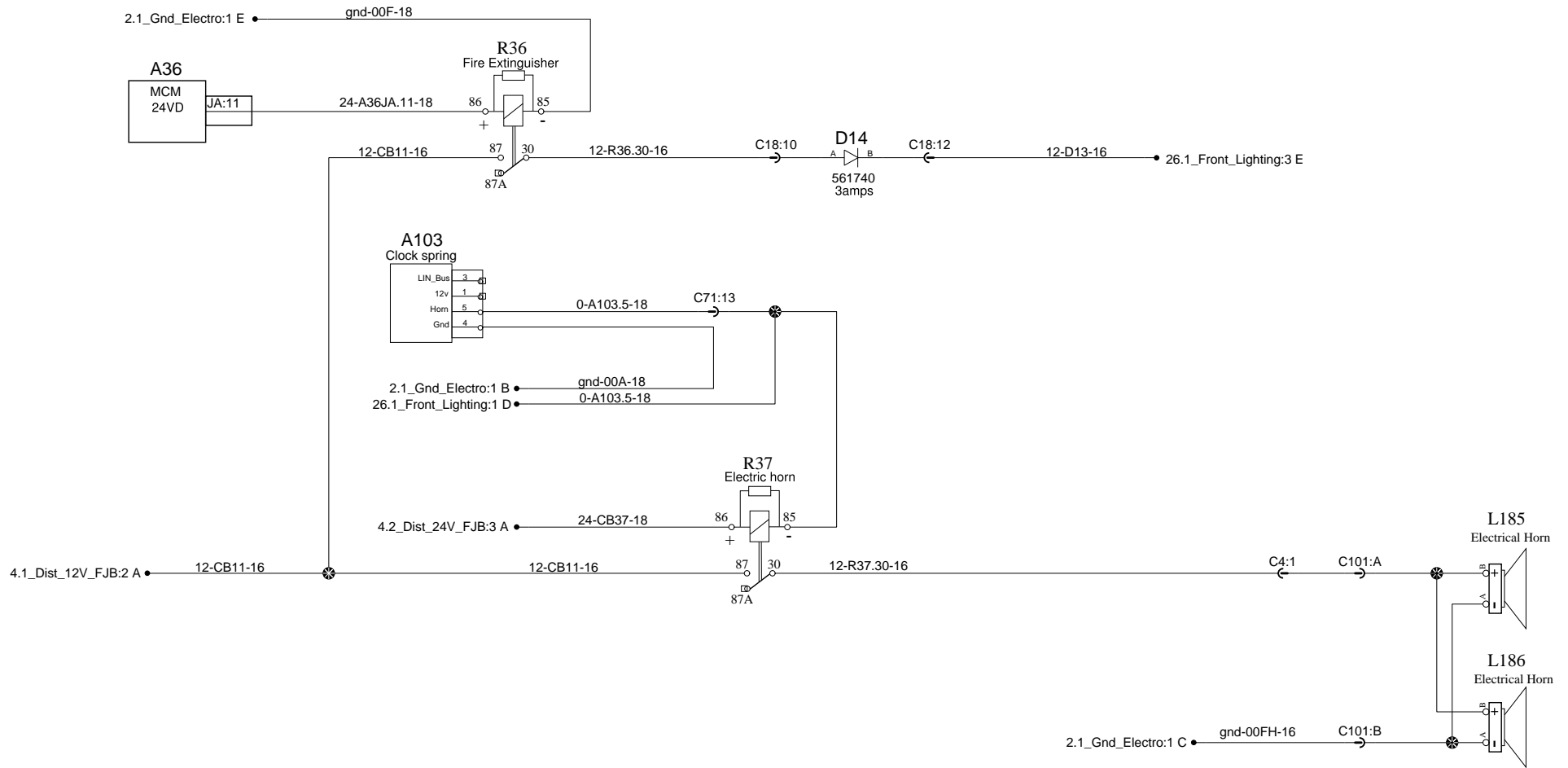

# Cluster

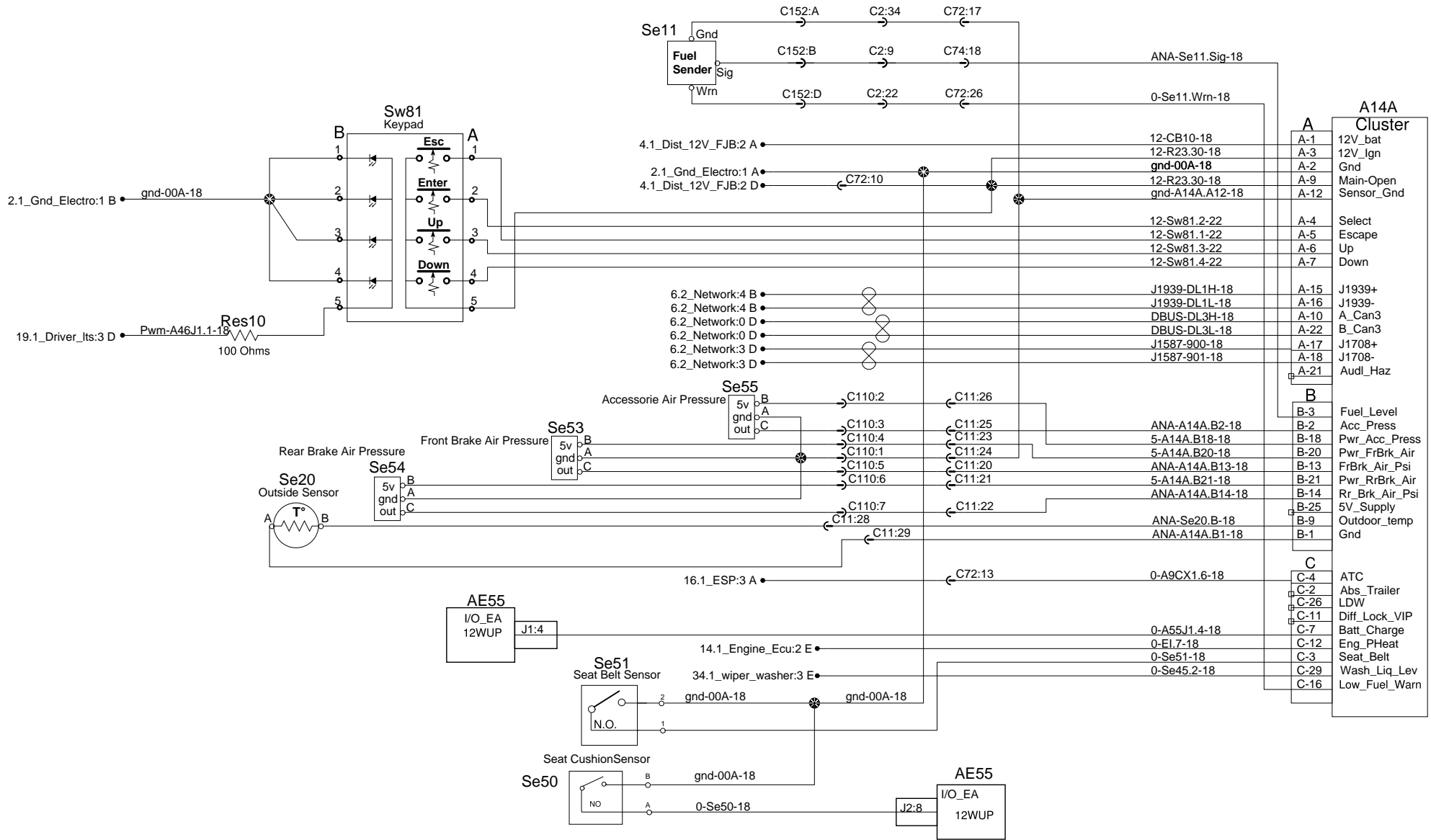

# Brake, Brake interlock and Retarder

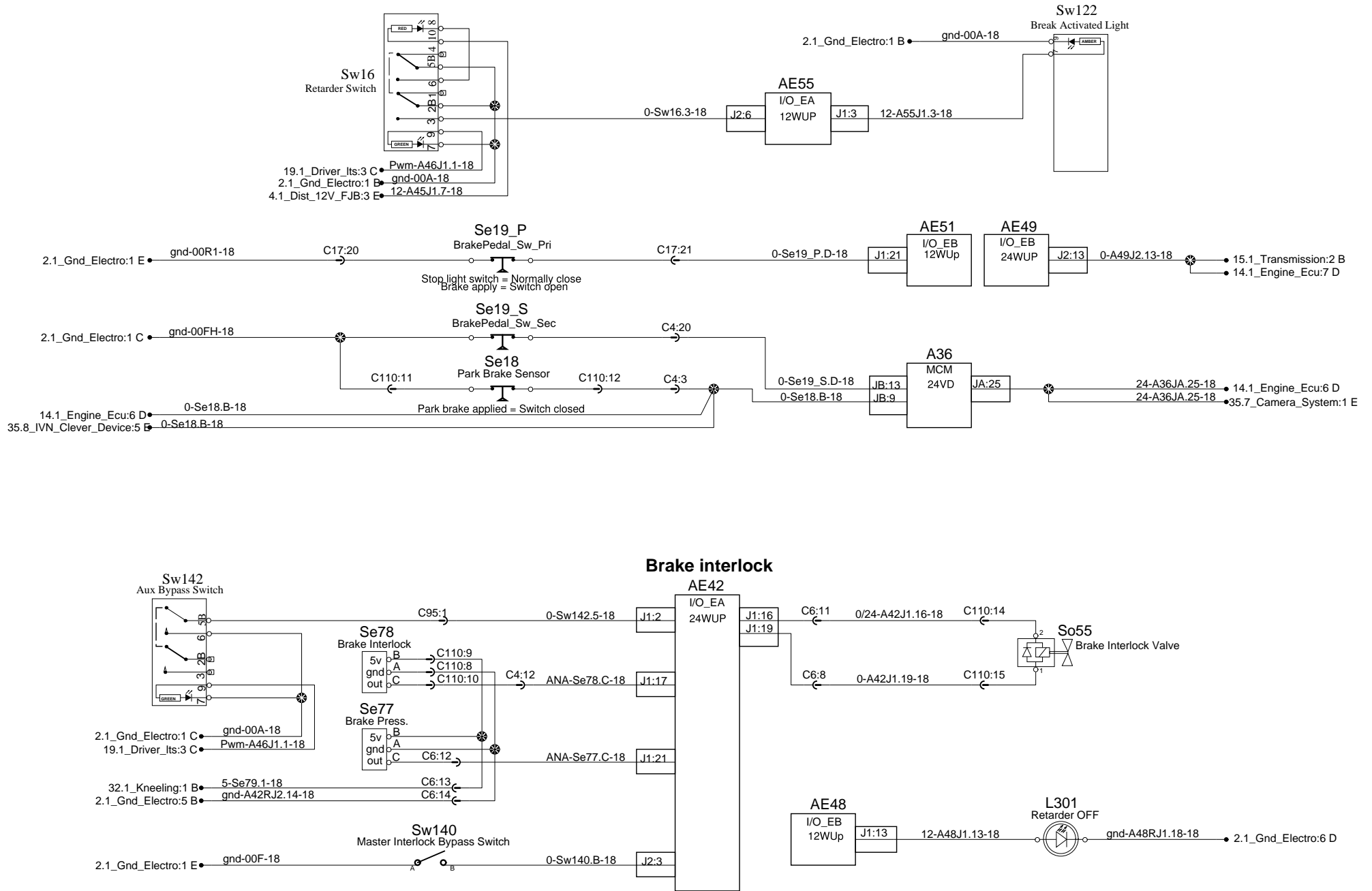

# Brake, Brake interlock and Retarder

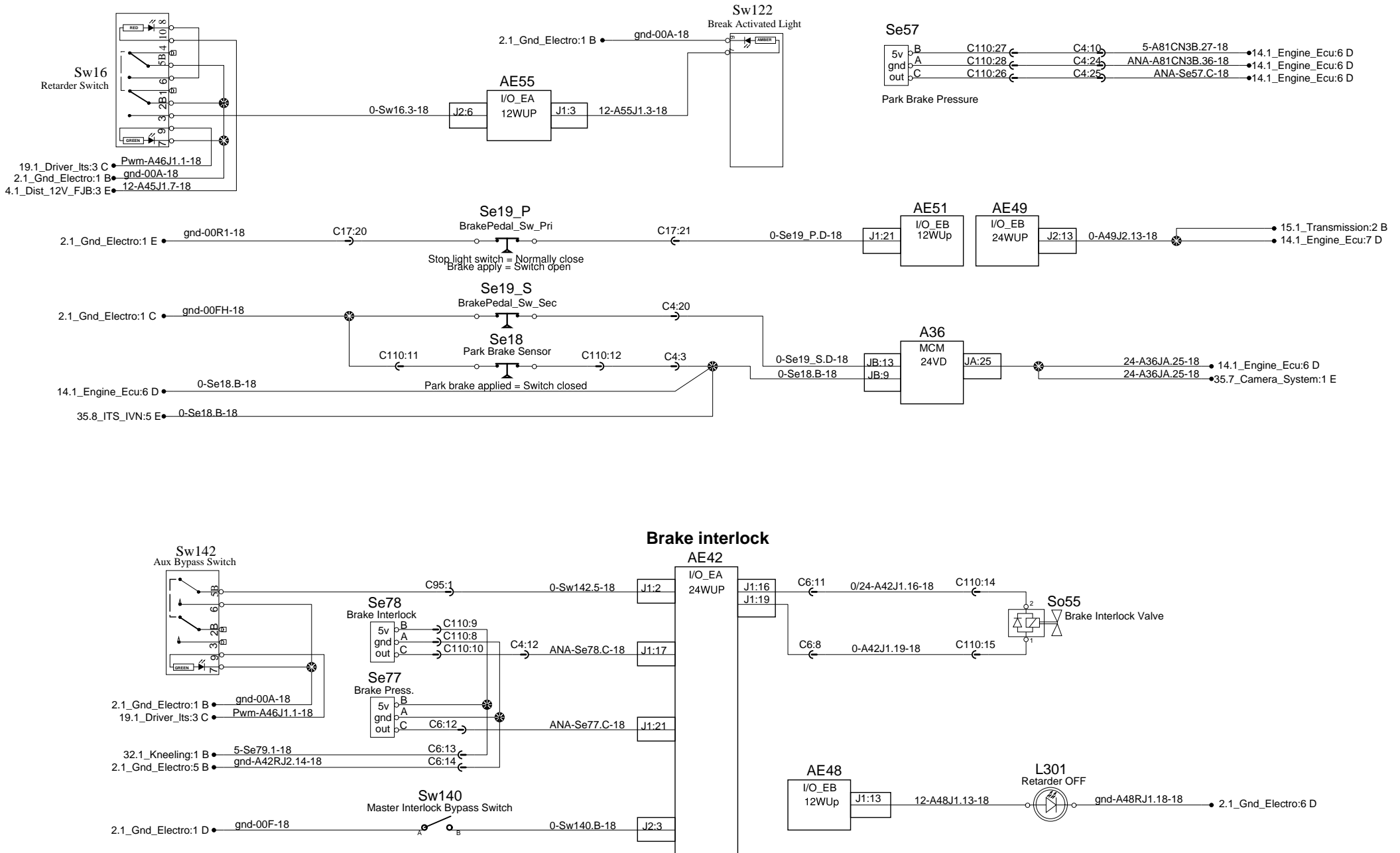

# Brake wear sensors

Wear sensor detail

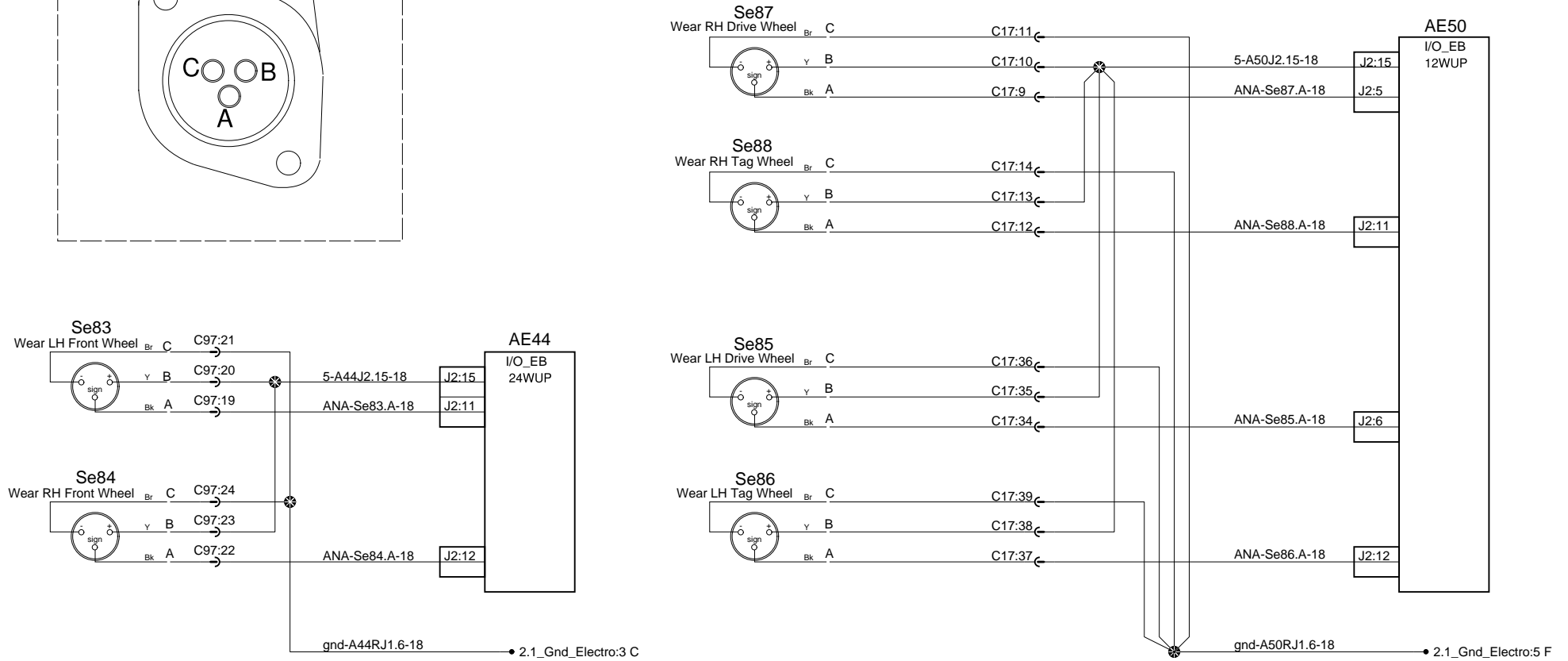
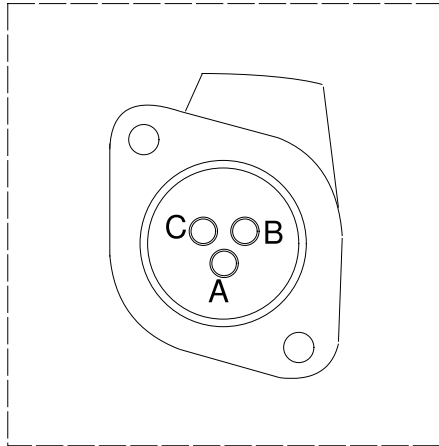

# Electric fans drive

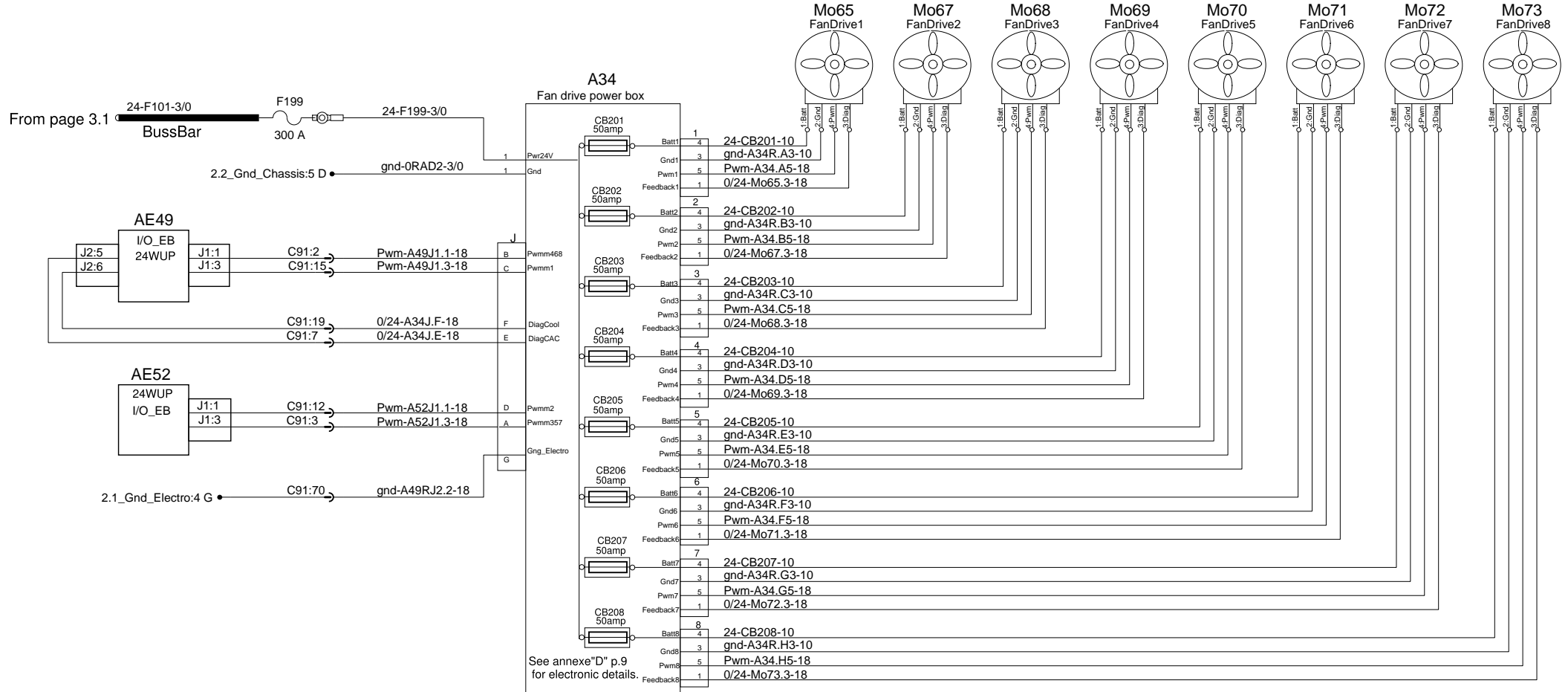



# Engine ECU Volvo

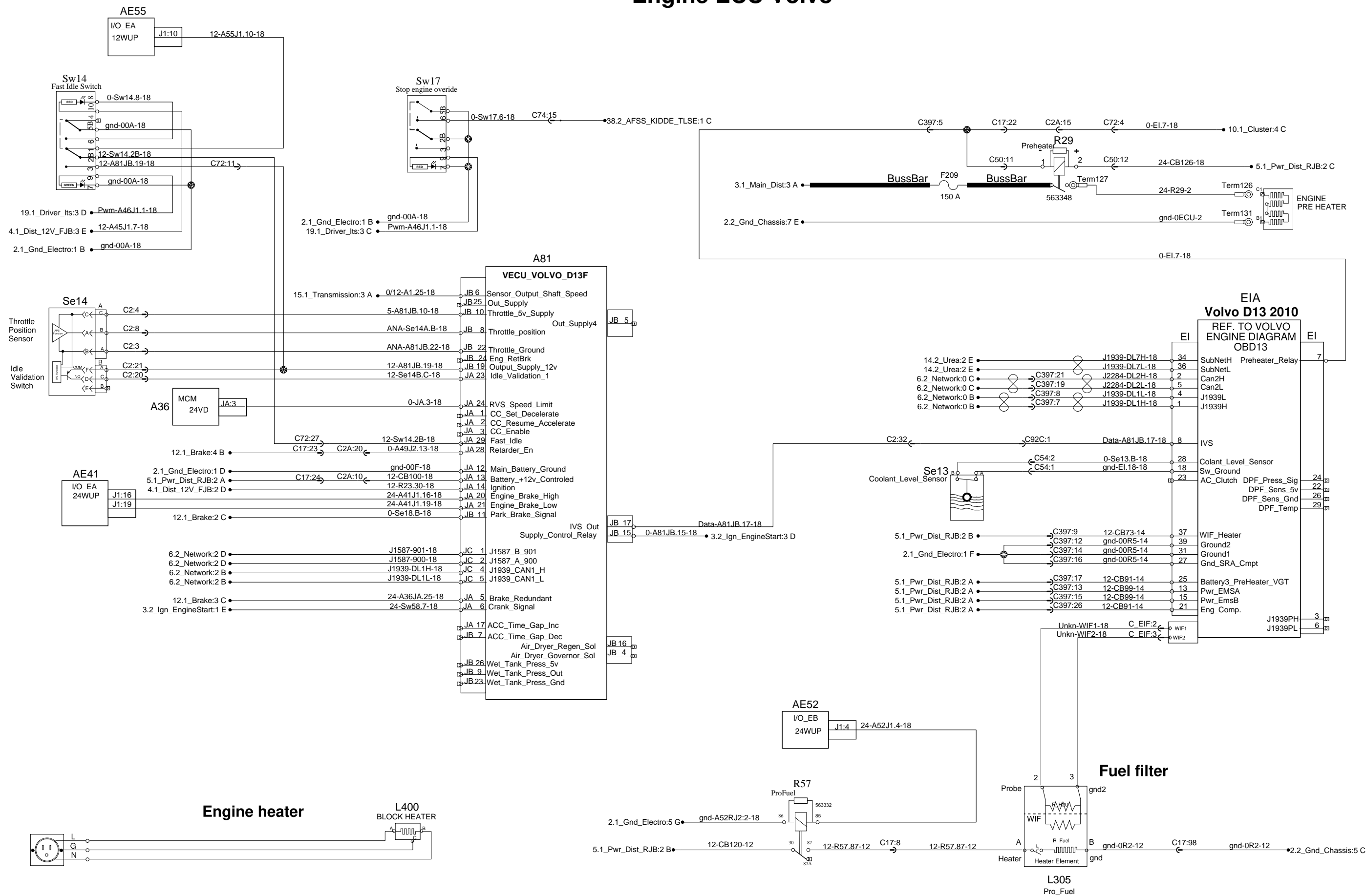

# Engine ECU Volvo

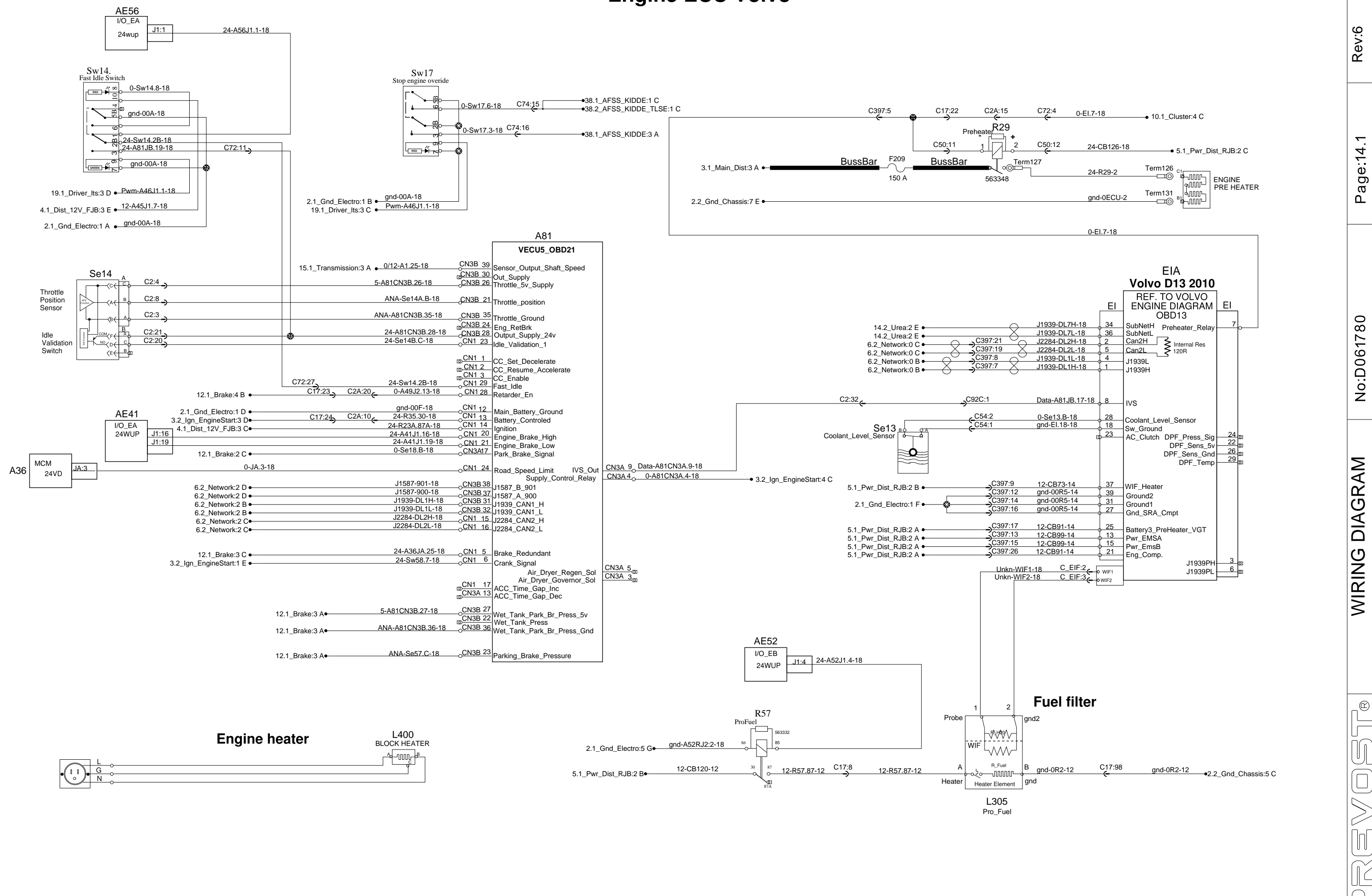

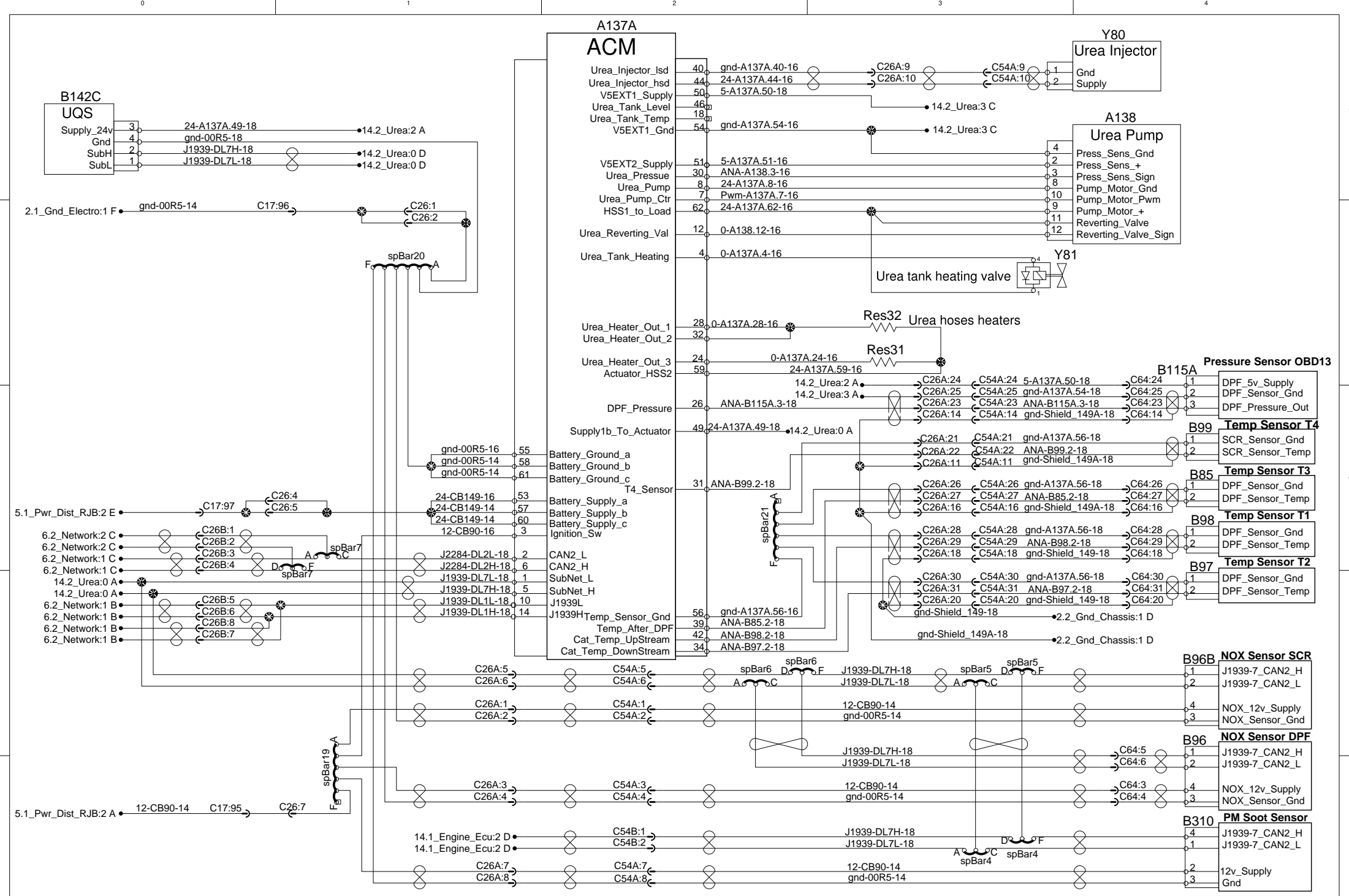

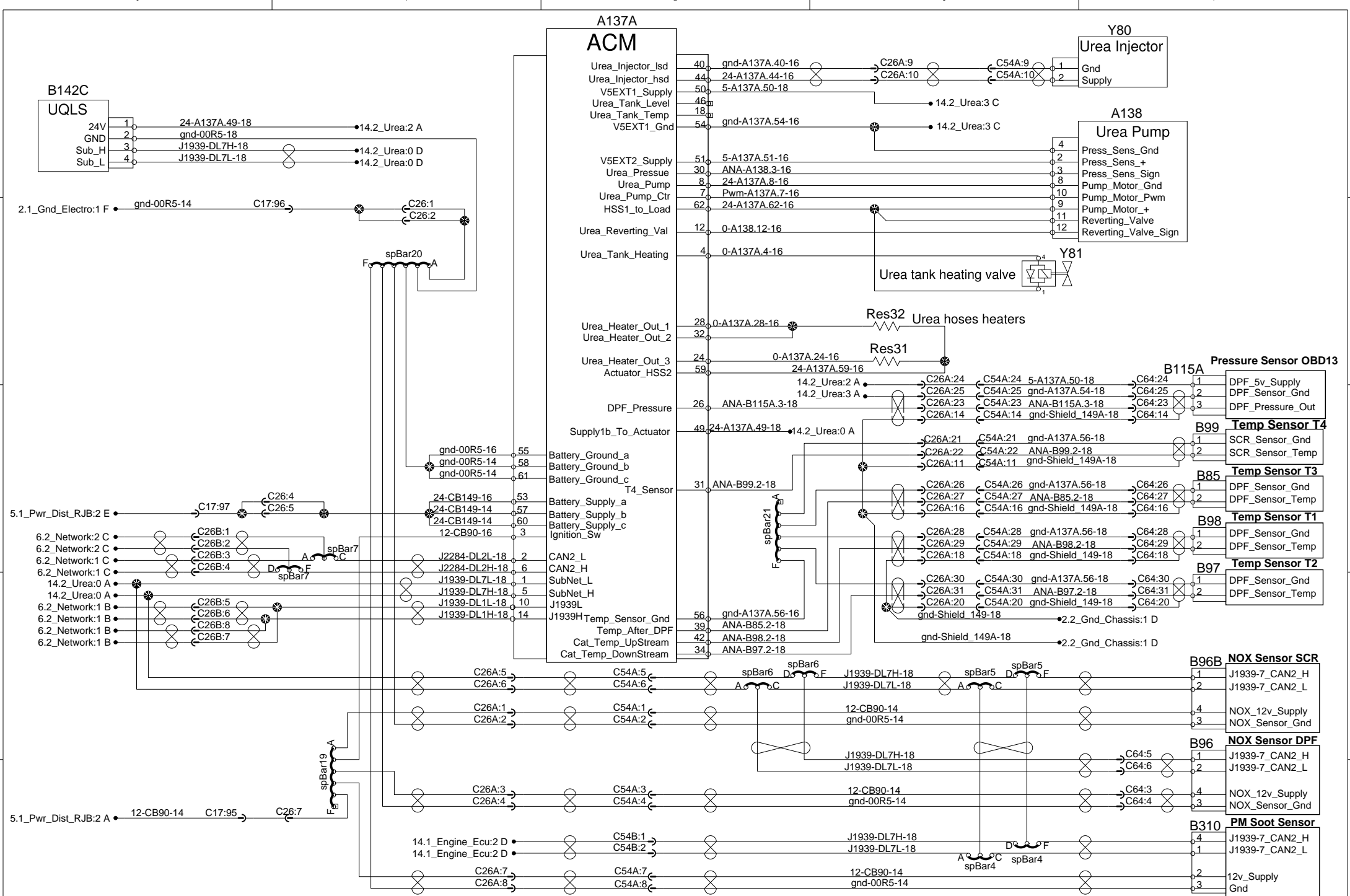

# Rear tachometer - Coolant level LED - Pro\_Fuel

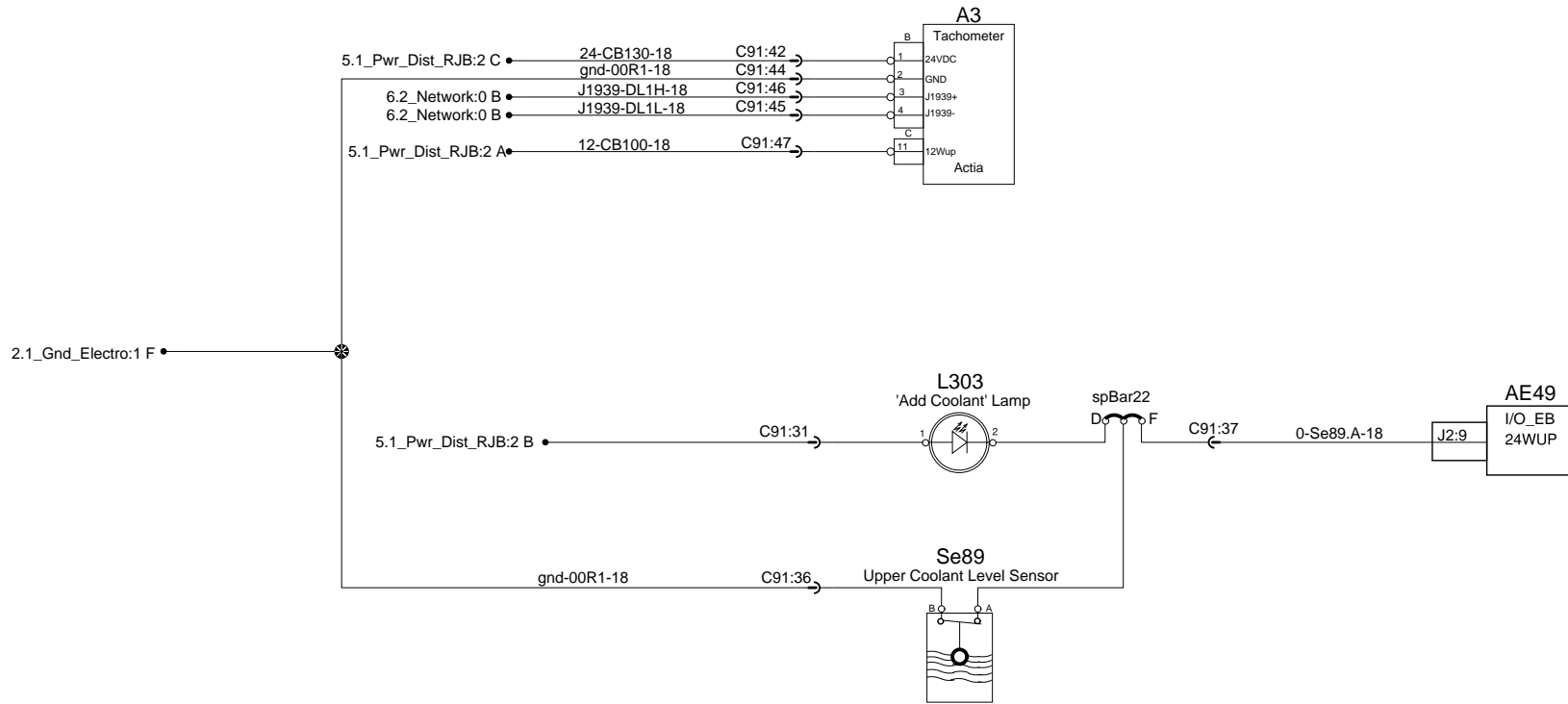

# Transmission Alisson Gen 5

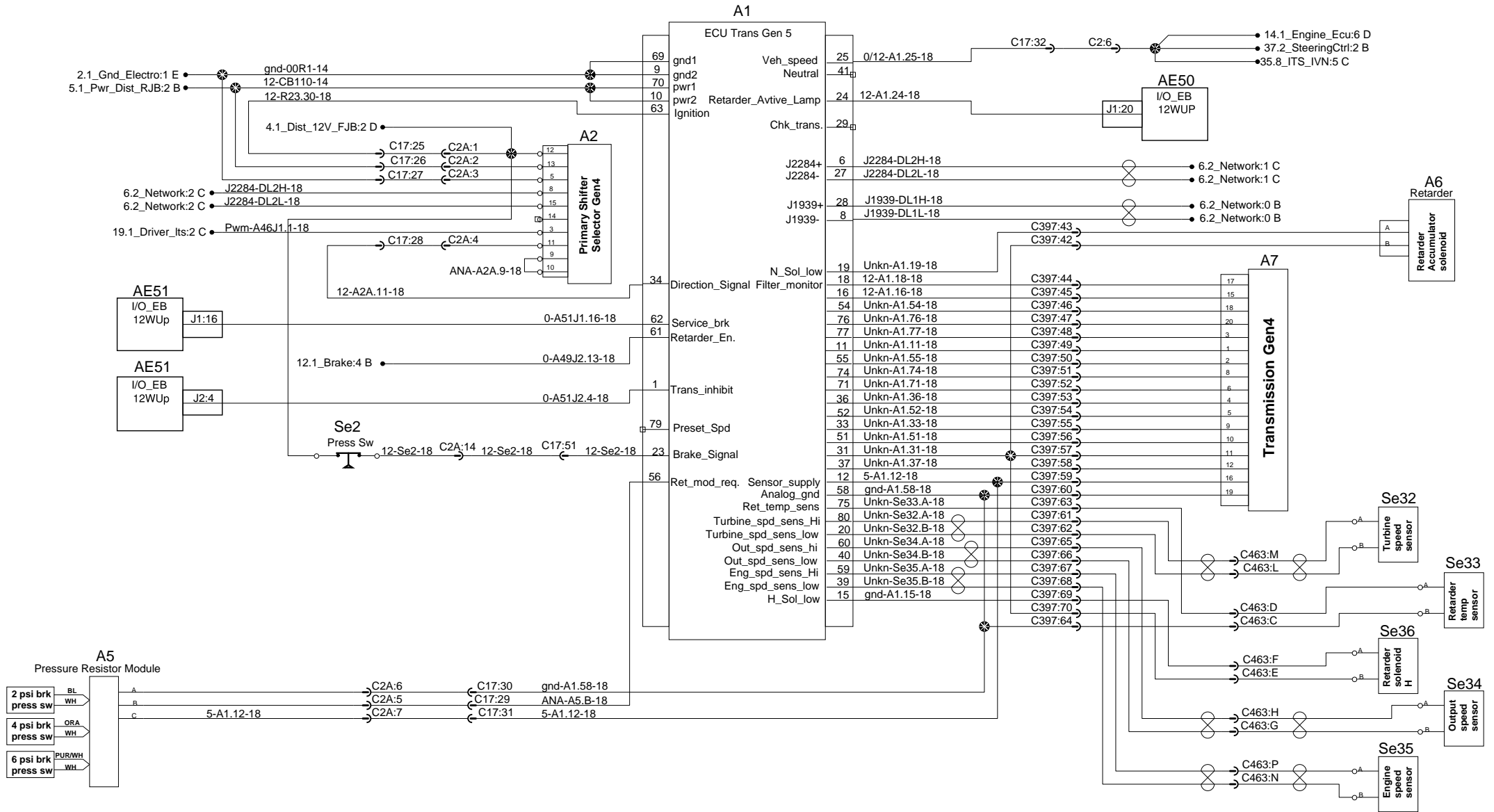

# ESP Electronic Stability Program

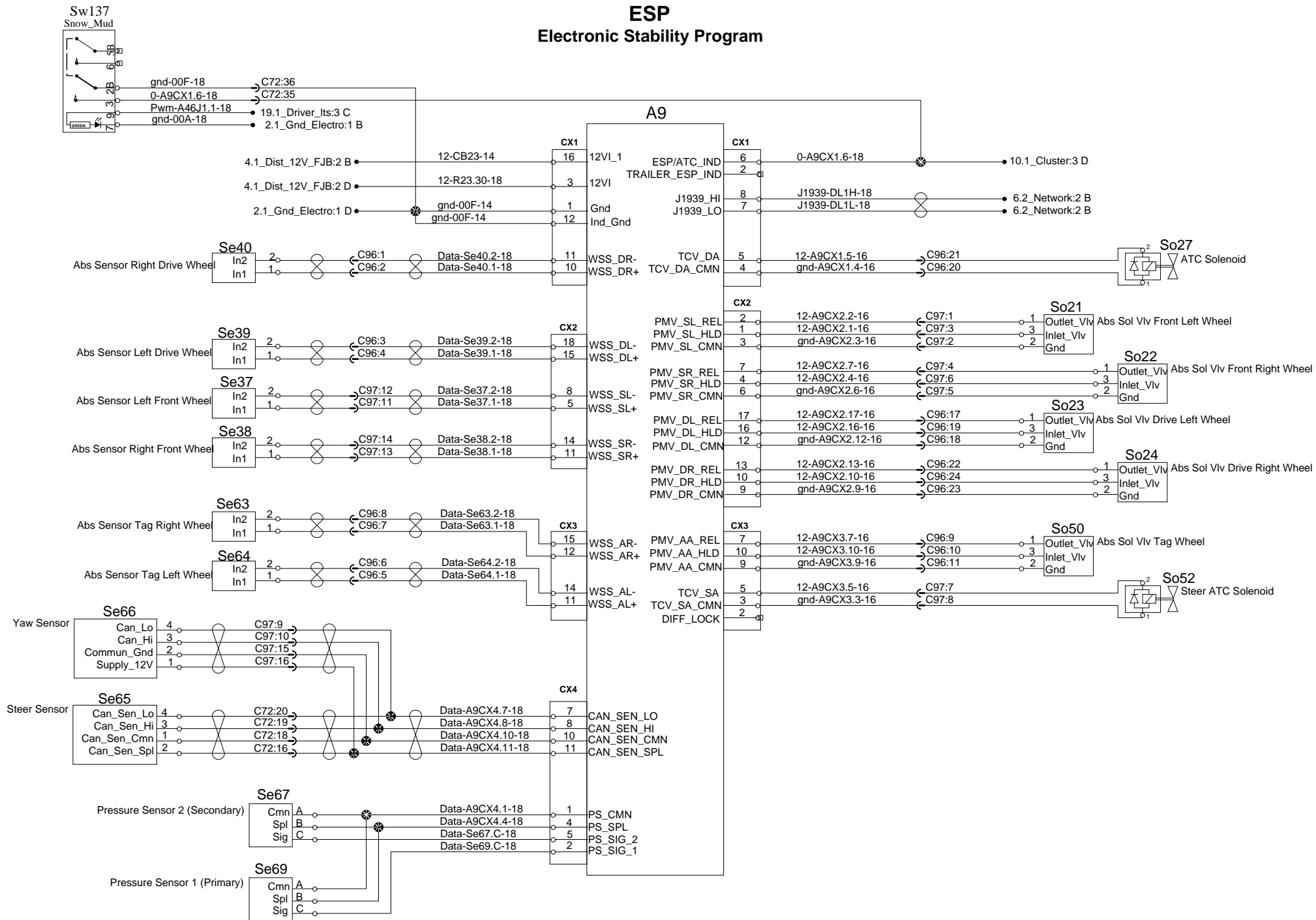

# Snow Chains

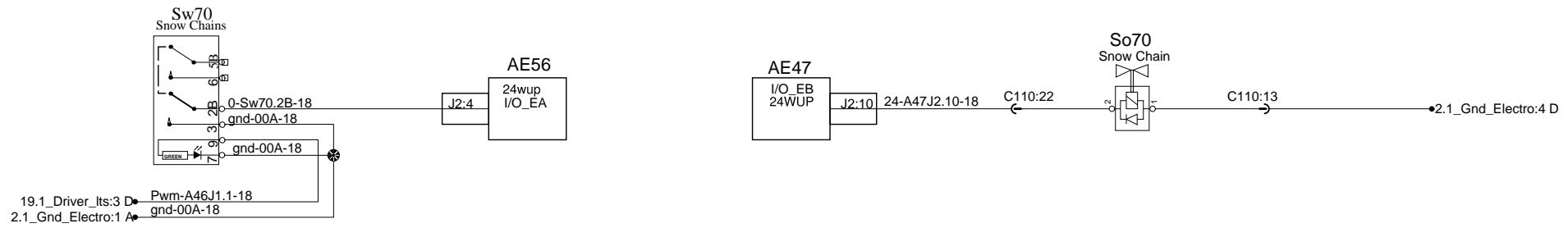



# Snow Chains

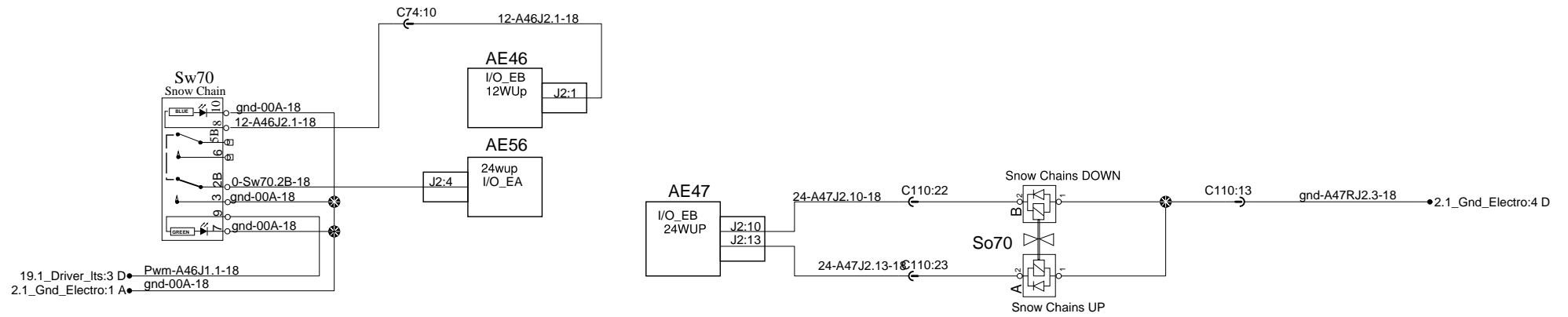

# Hvac defroster

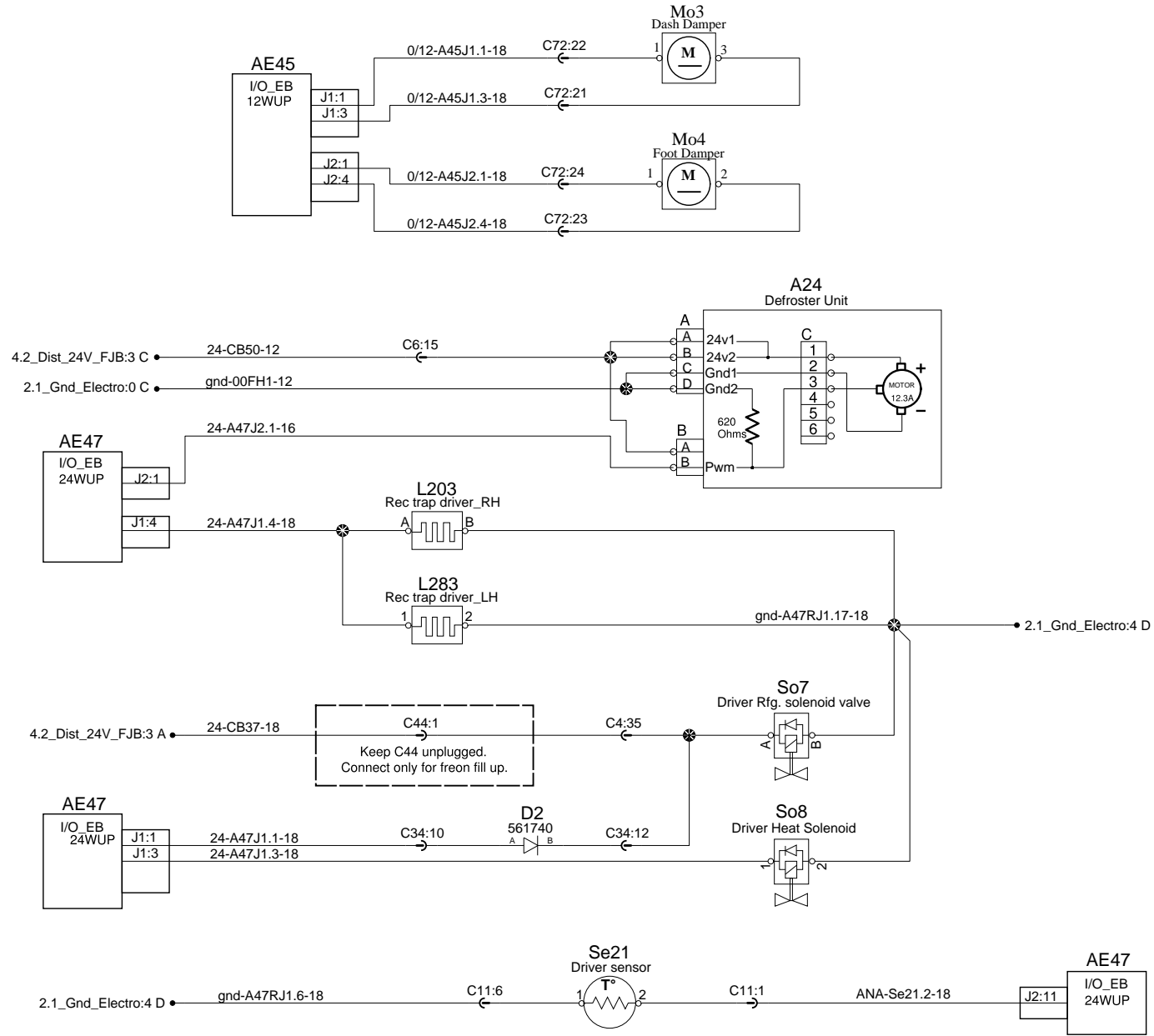

# HVAC passengers

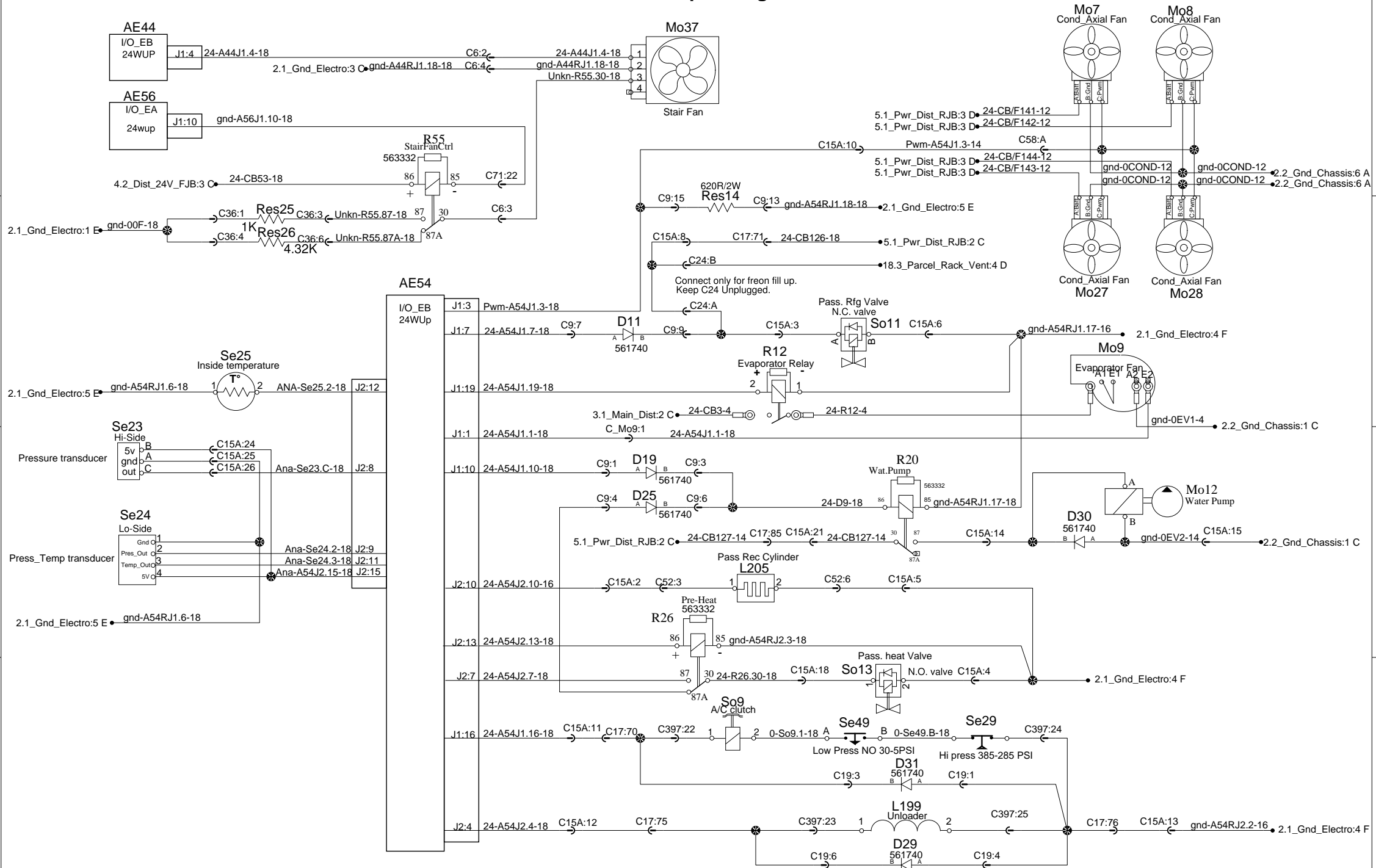

# Parcel rack A/C system

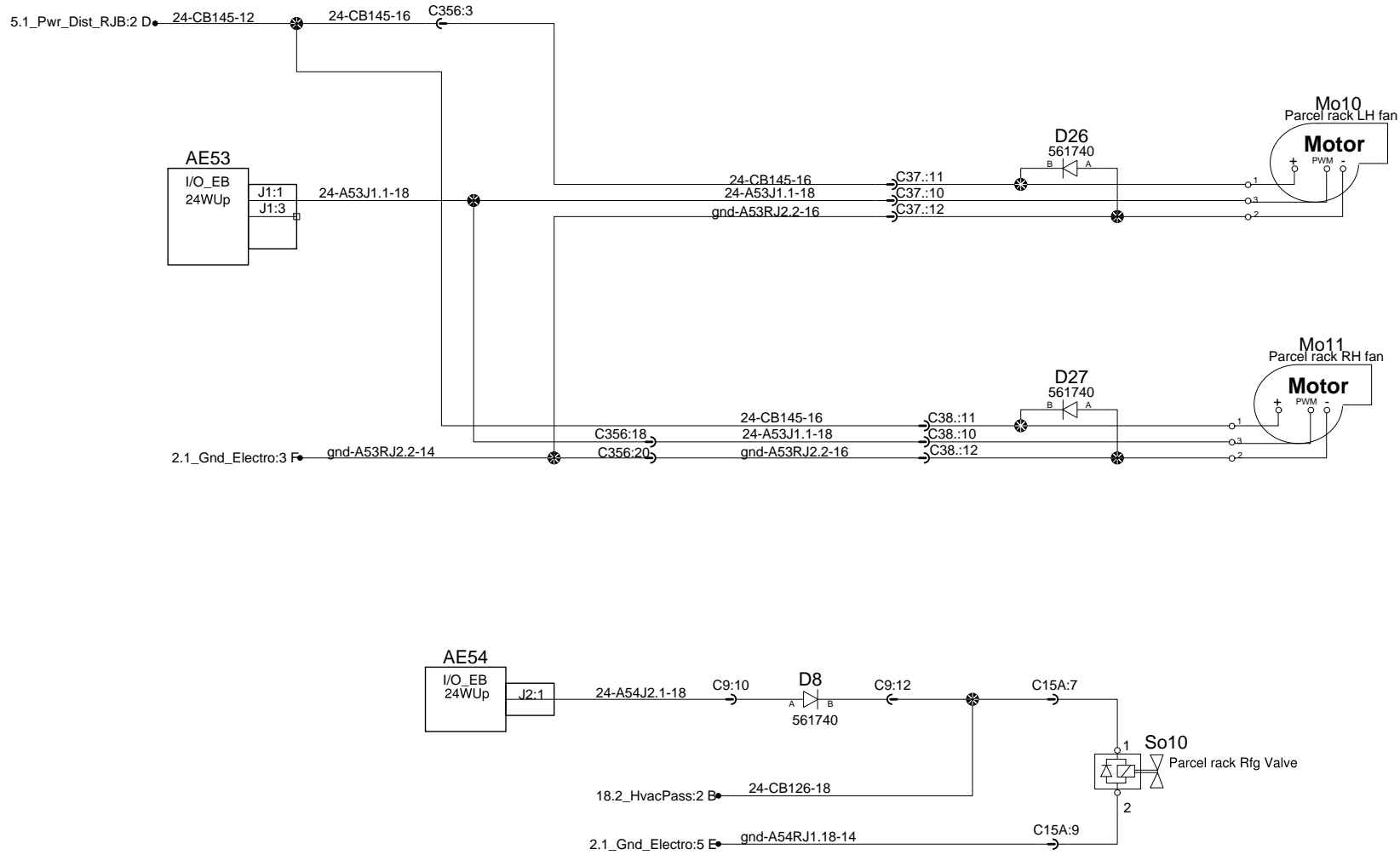

# Parcel rack A/C system

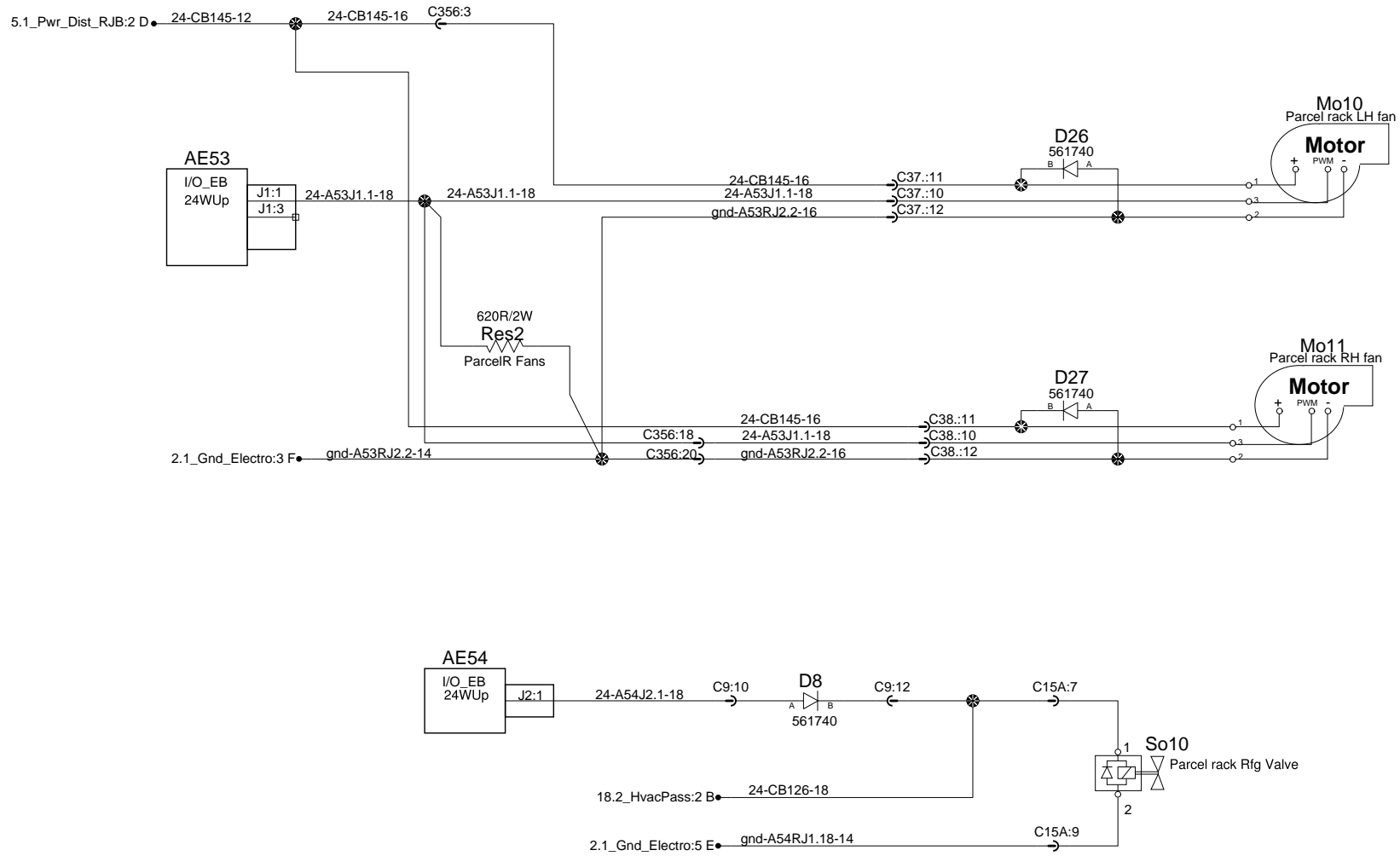

### Upper defrost option

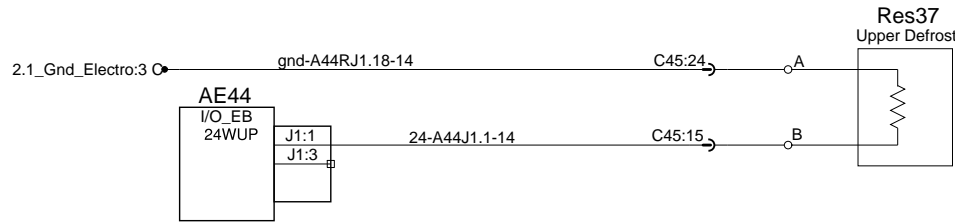

# Driver's lights

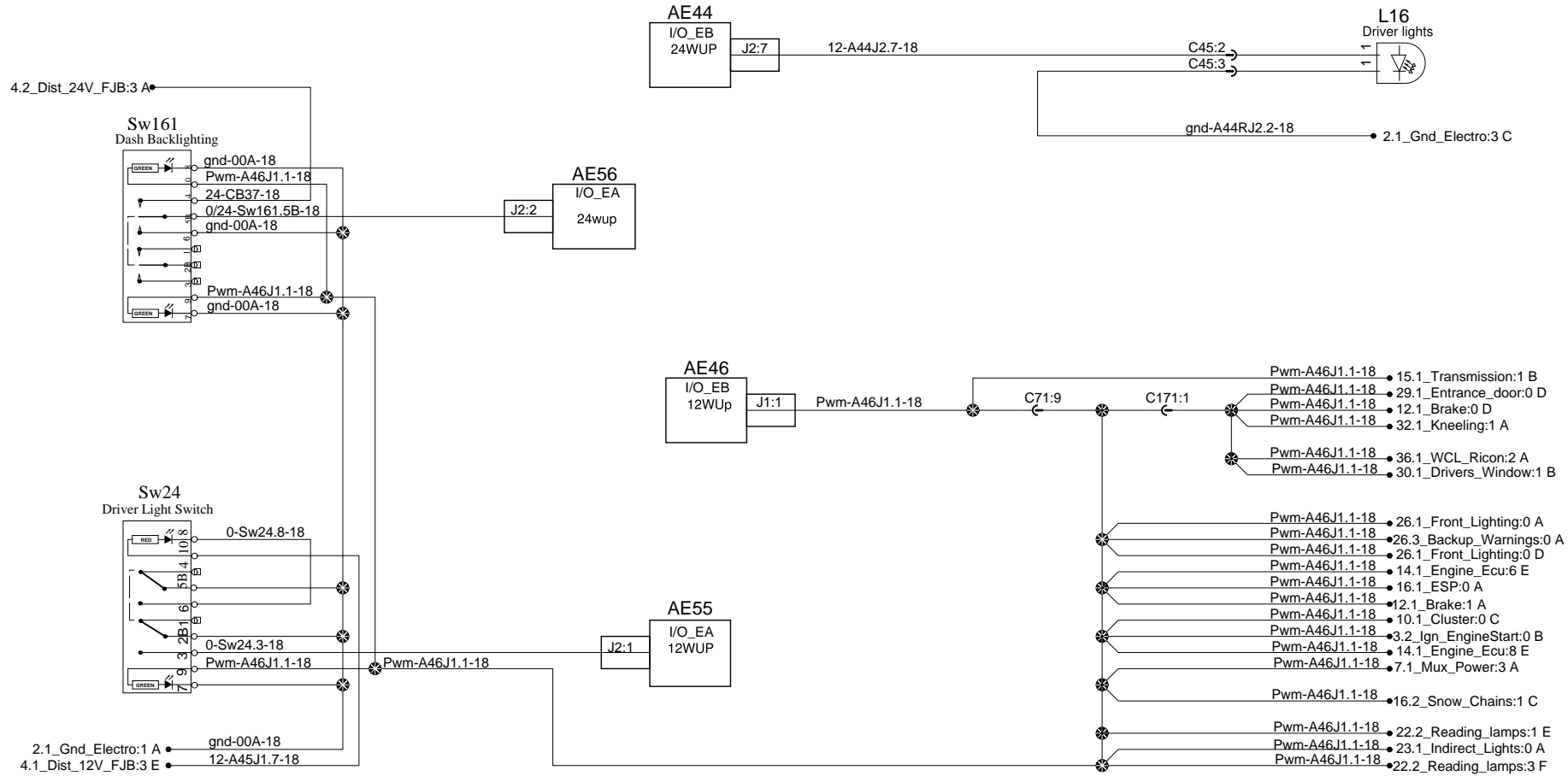

# Emergency & Aisle lights

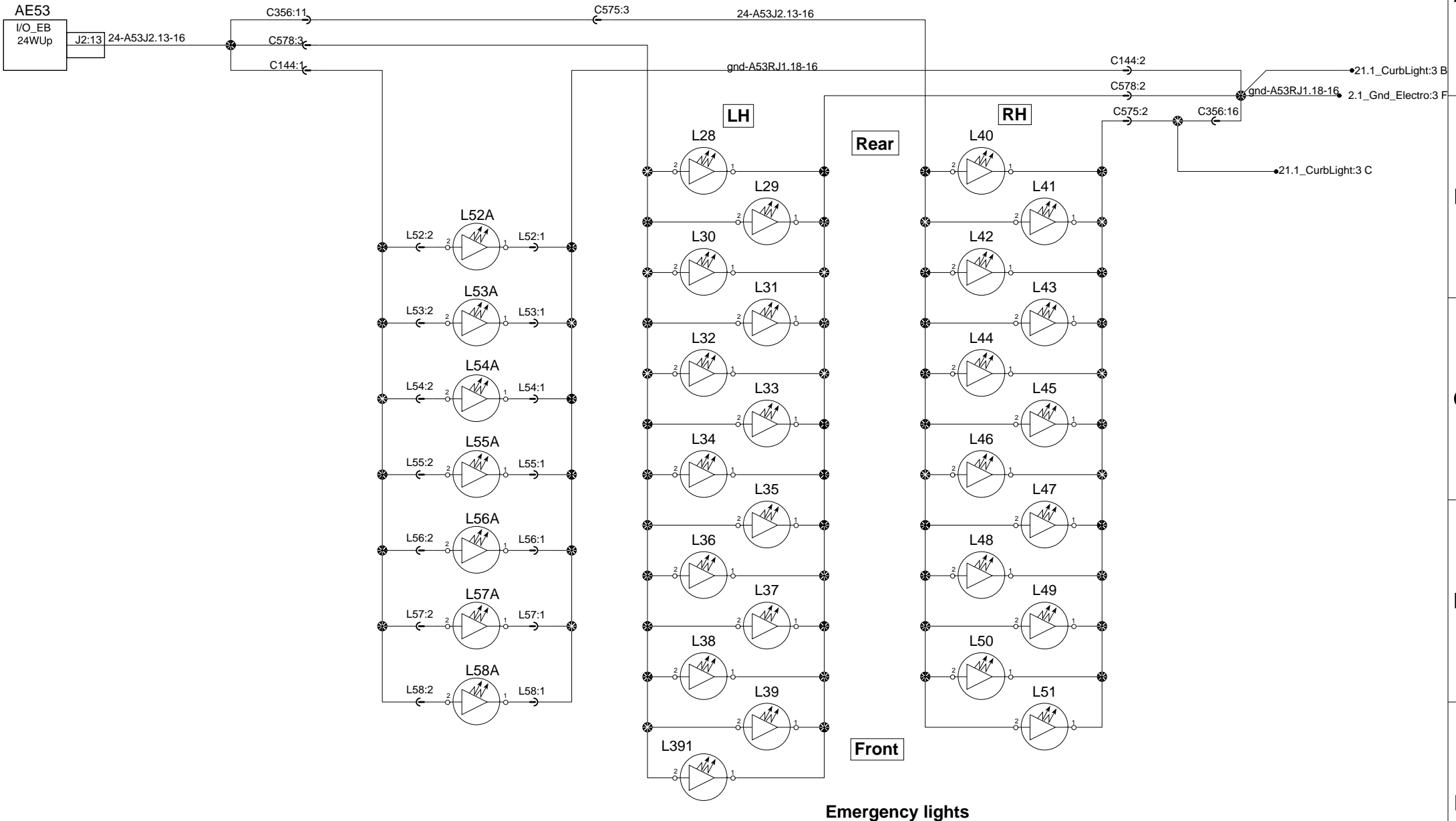



# Curb Lights

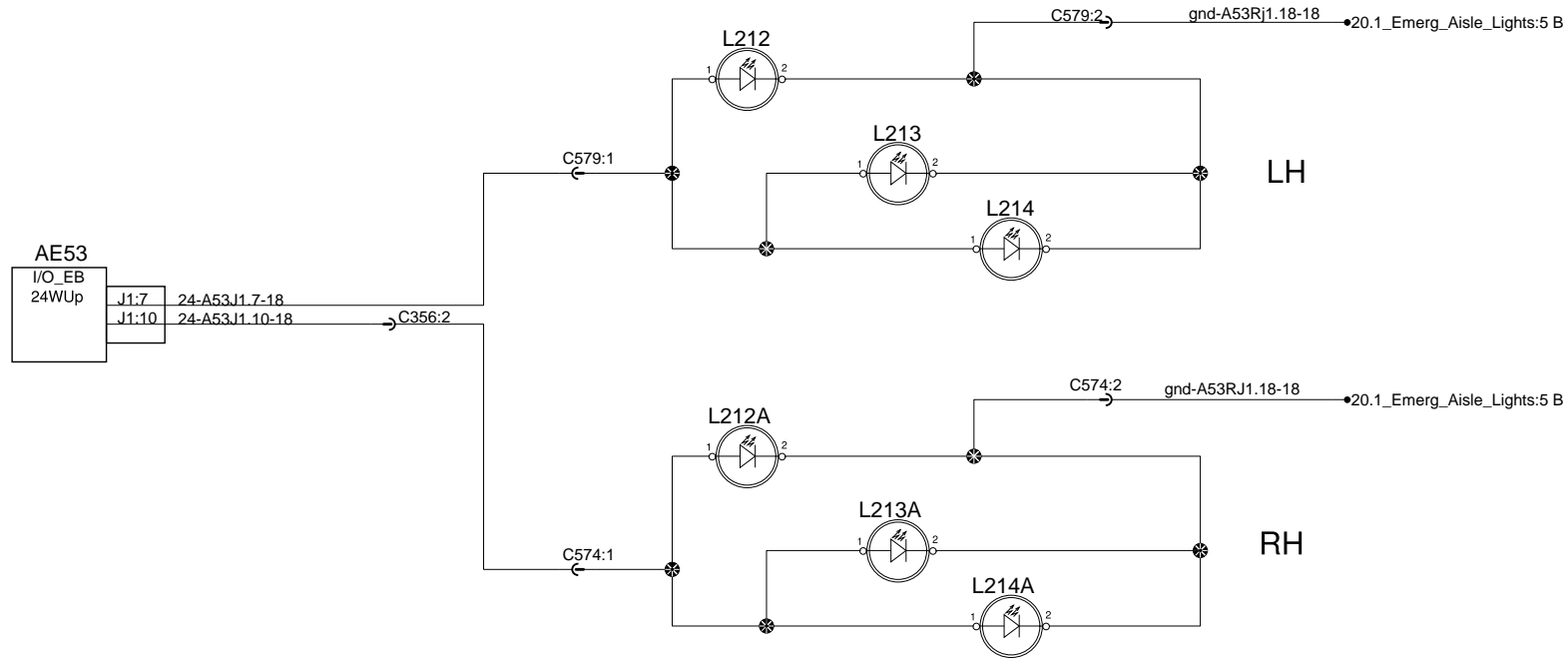

# Reading Lamp and Next Stop Request

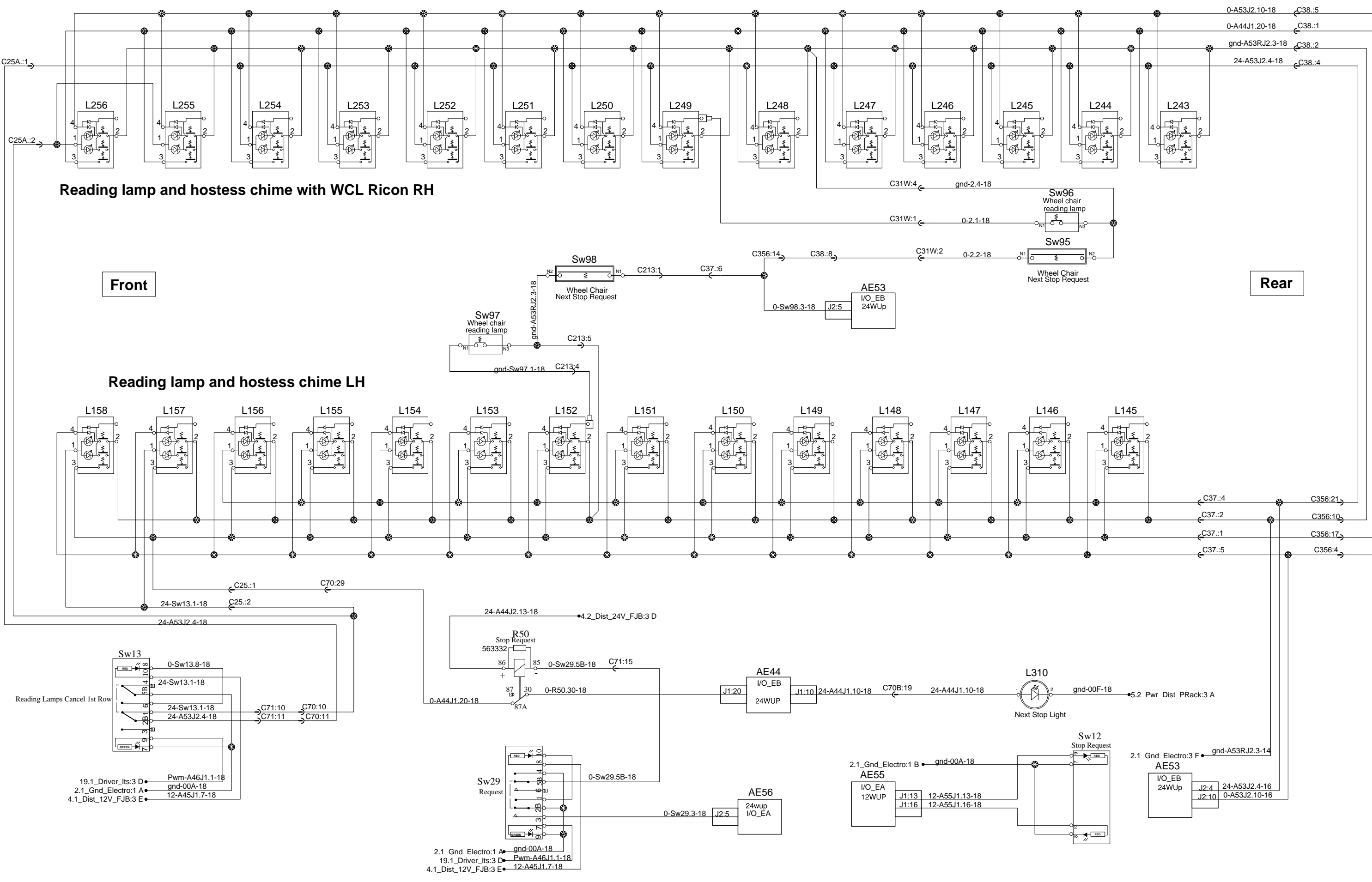

# Indirect lighting

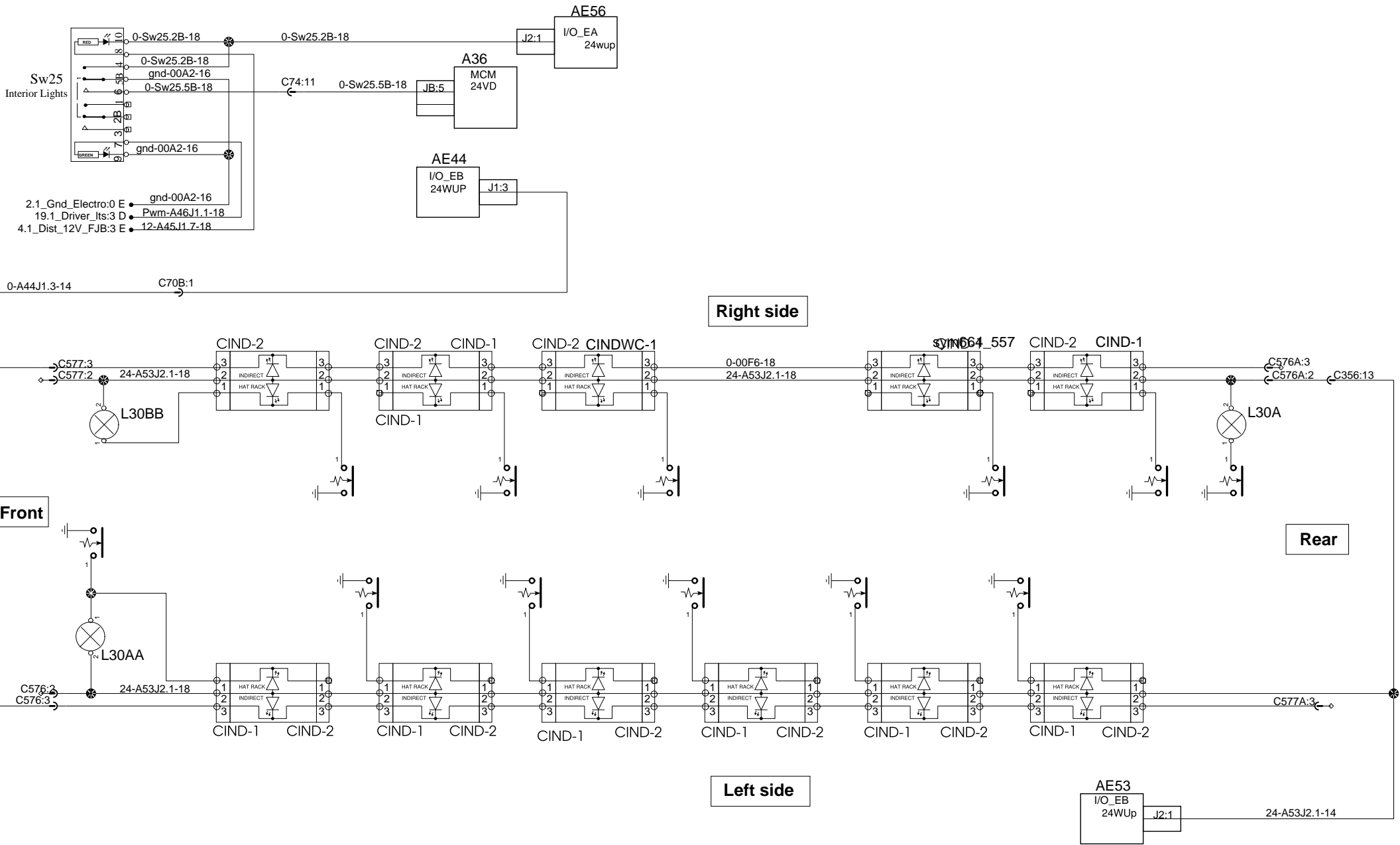

# Indirect lighting

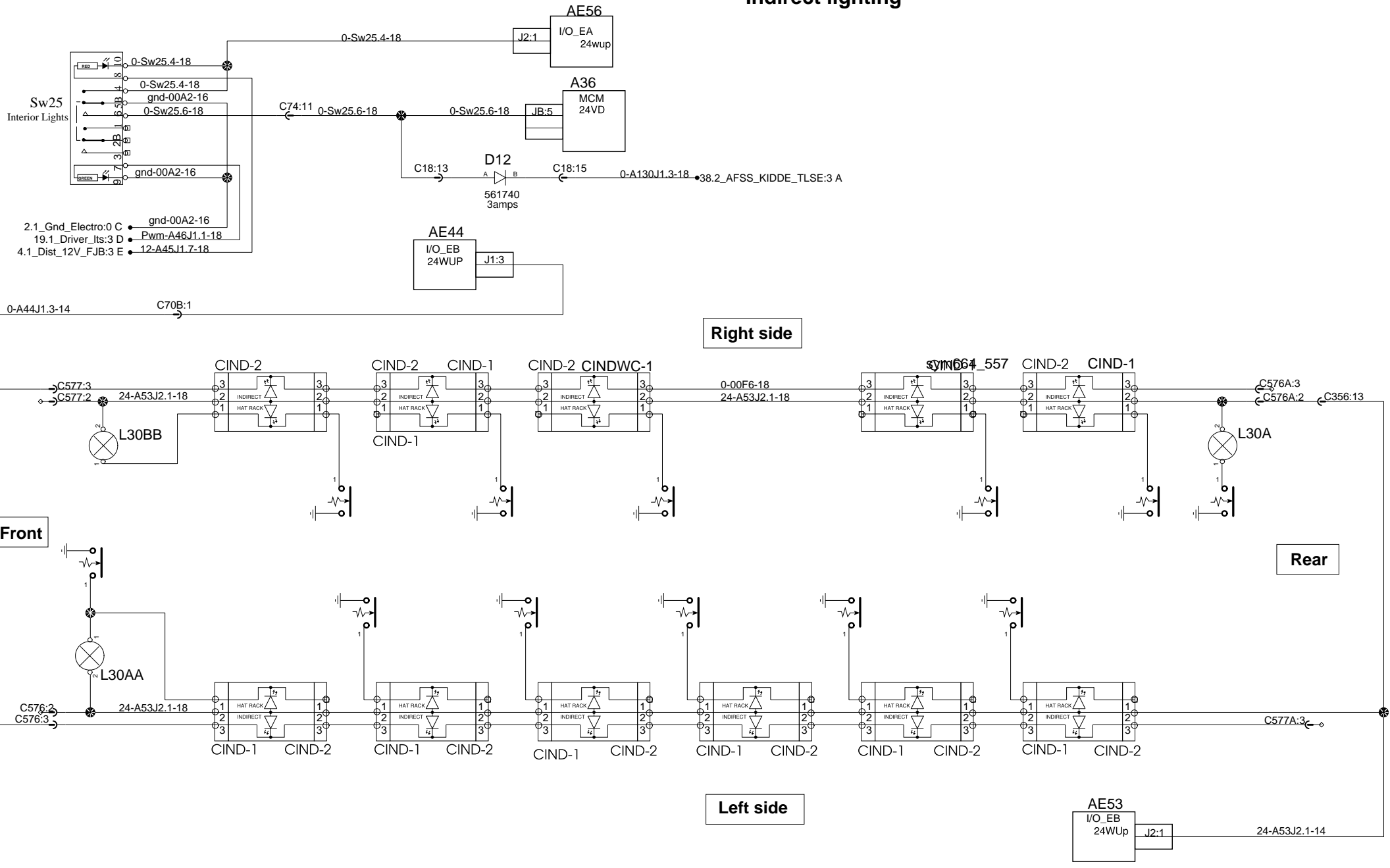

## Engine and RJB Cmpt lighting

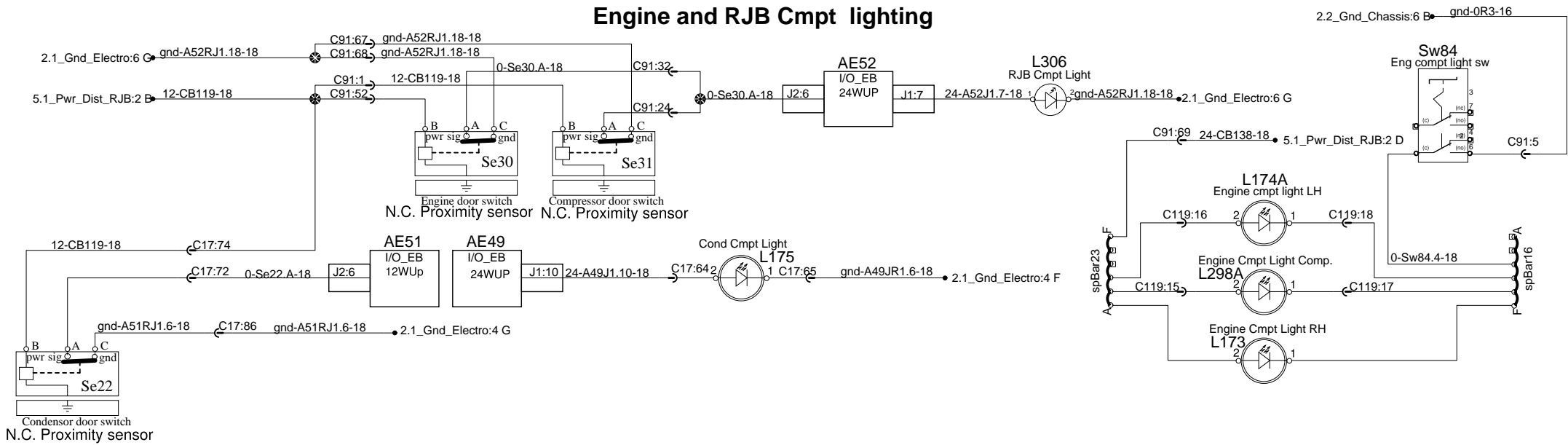

## Luggages compartment lighting

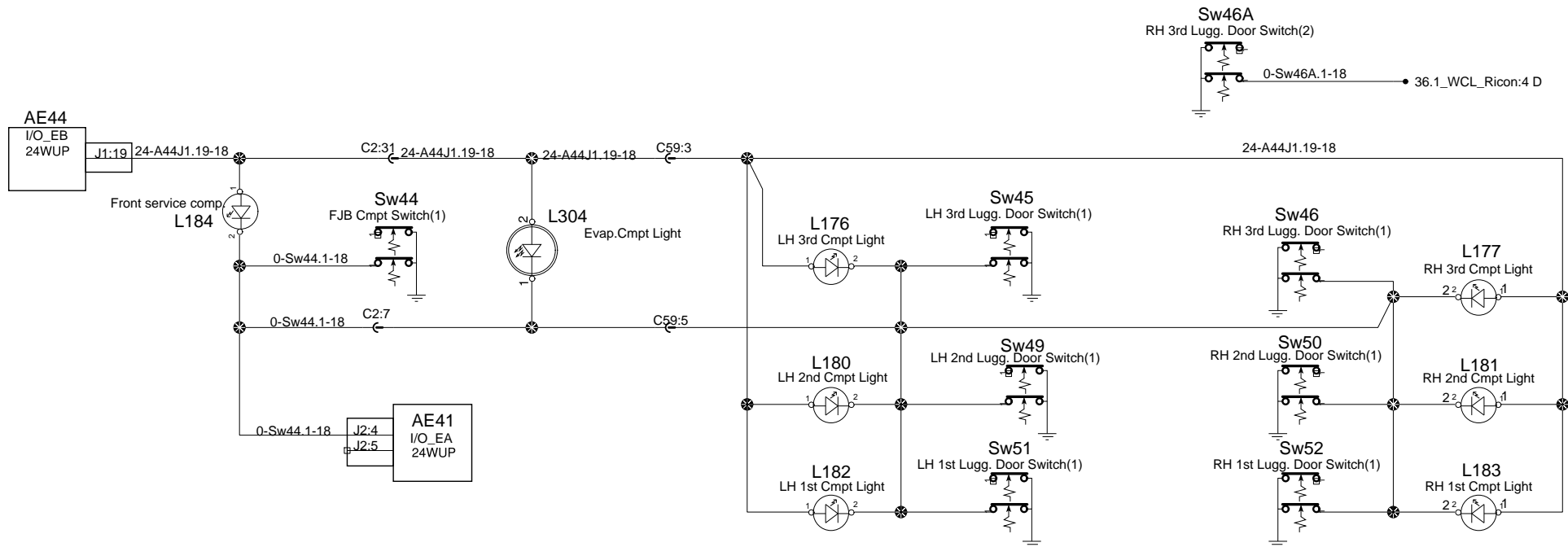

# Front flashers, Markers and Head lights

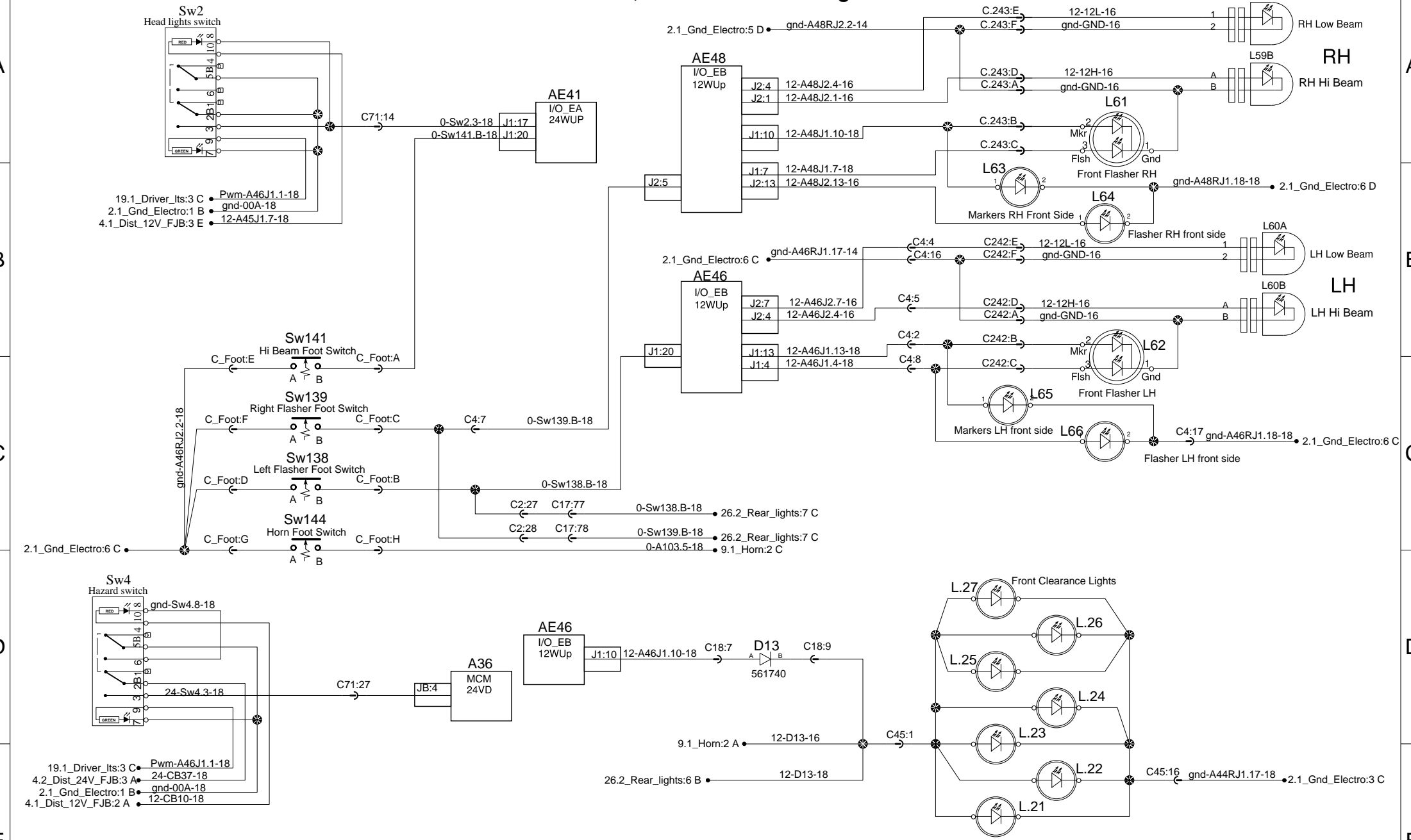

# Rear flashers, Markers, Tail and stop lights

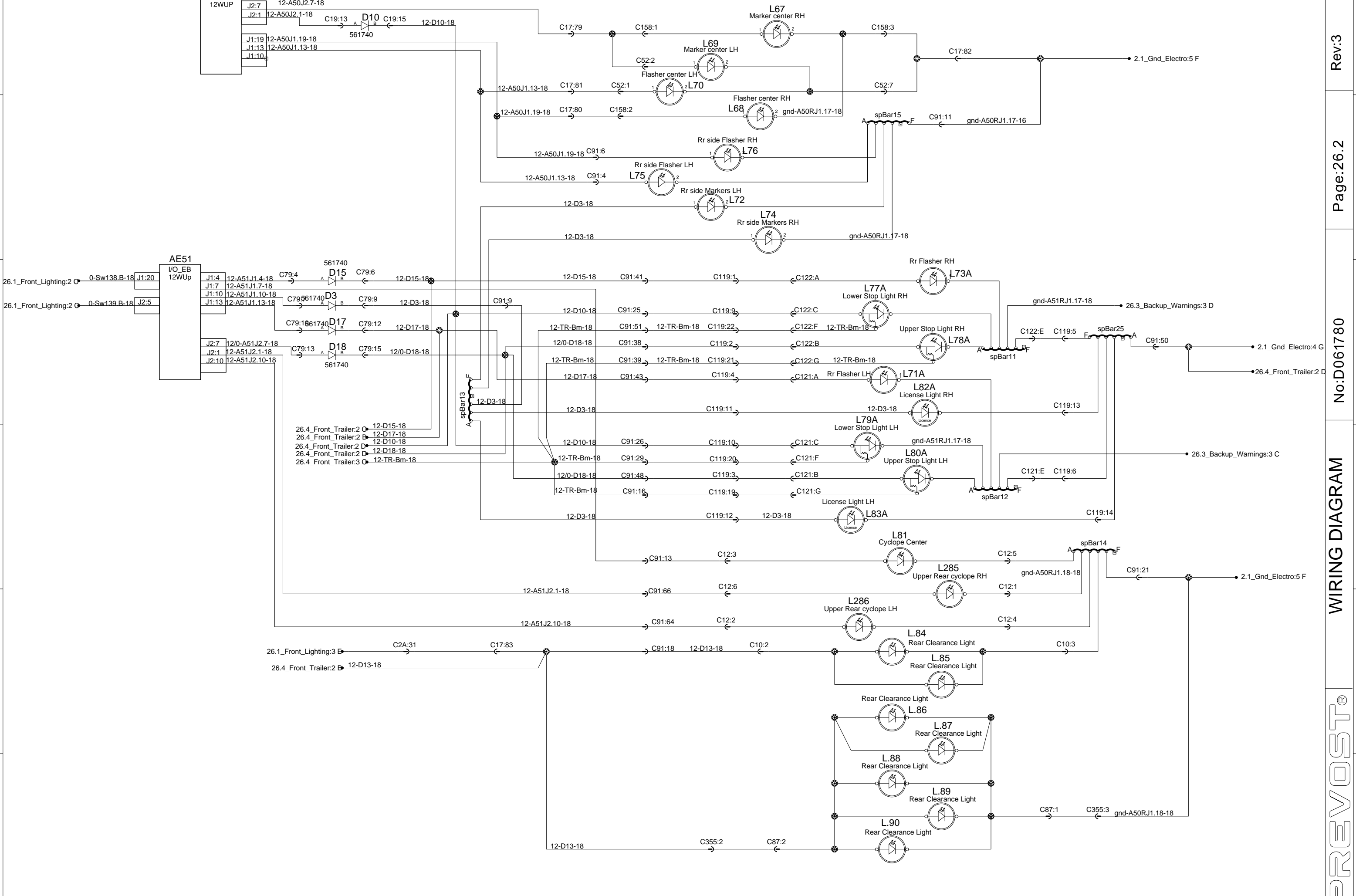

# Backup warnings

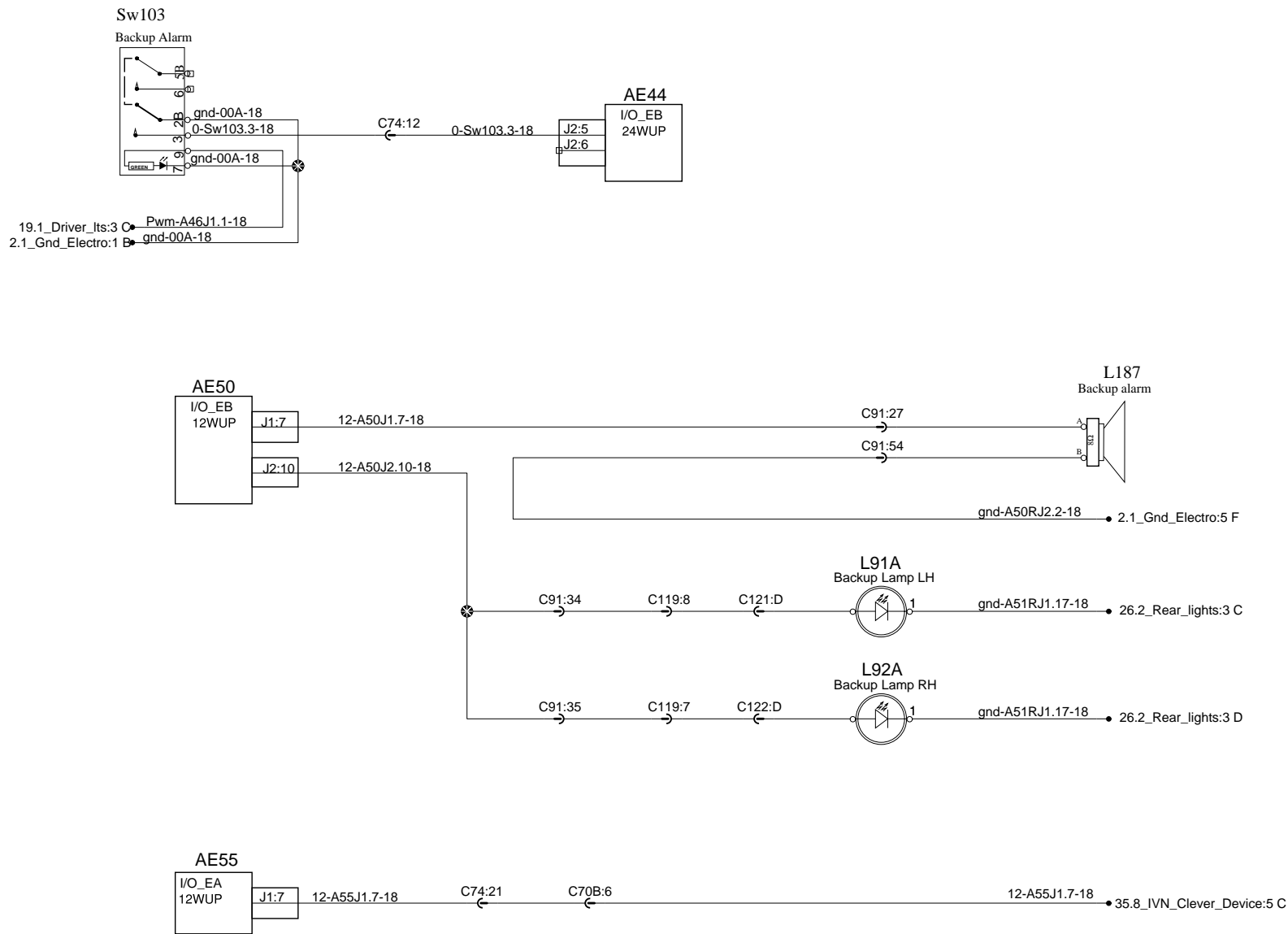



# Front Trailer

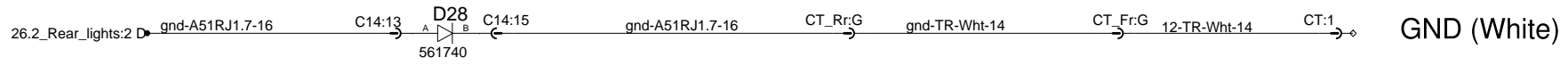
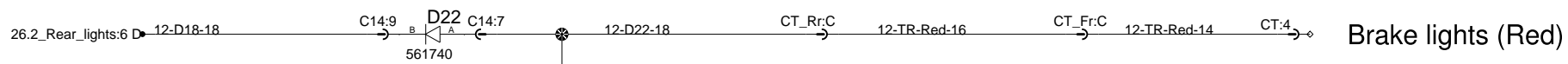
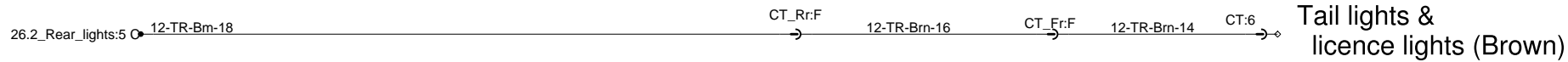
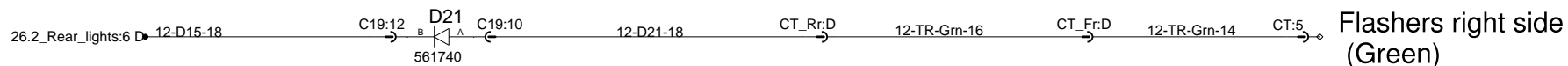
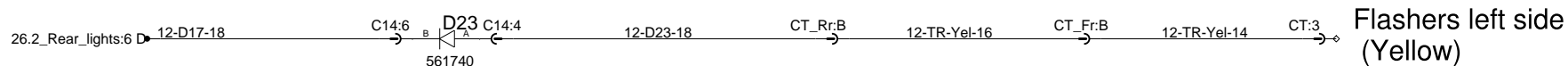
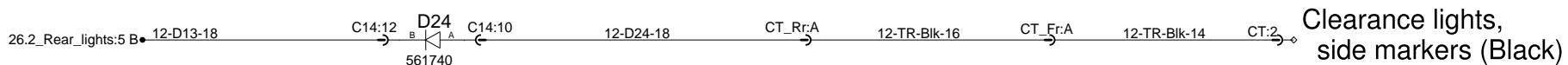

# Destination Sign and Farebox

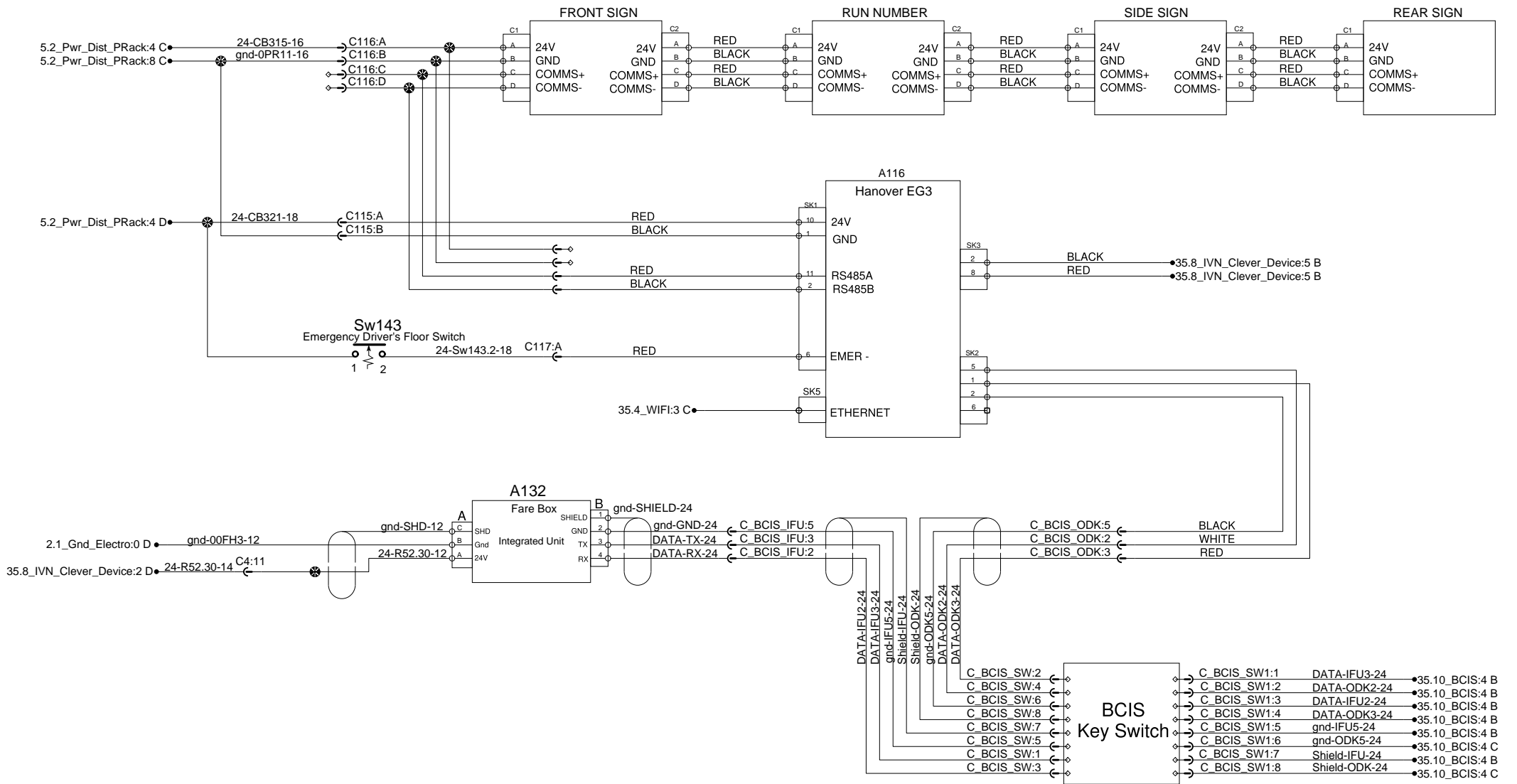

# Destination Sign and Farebox

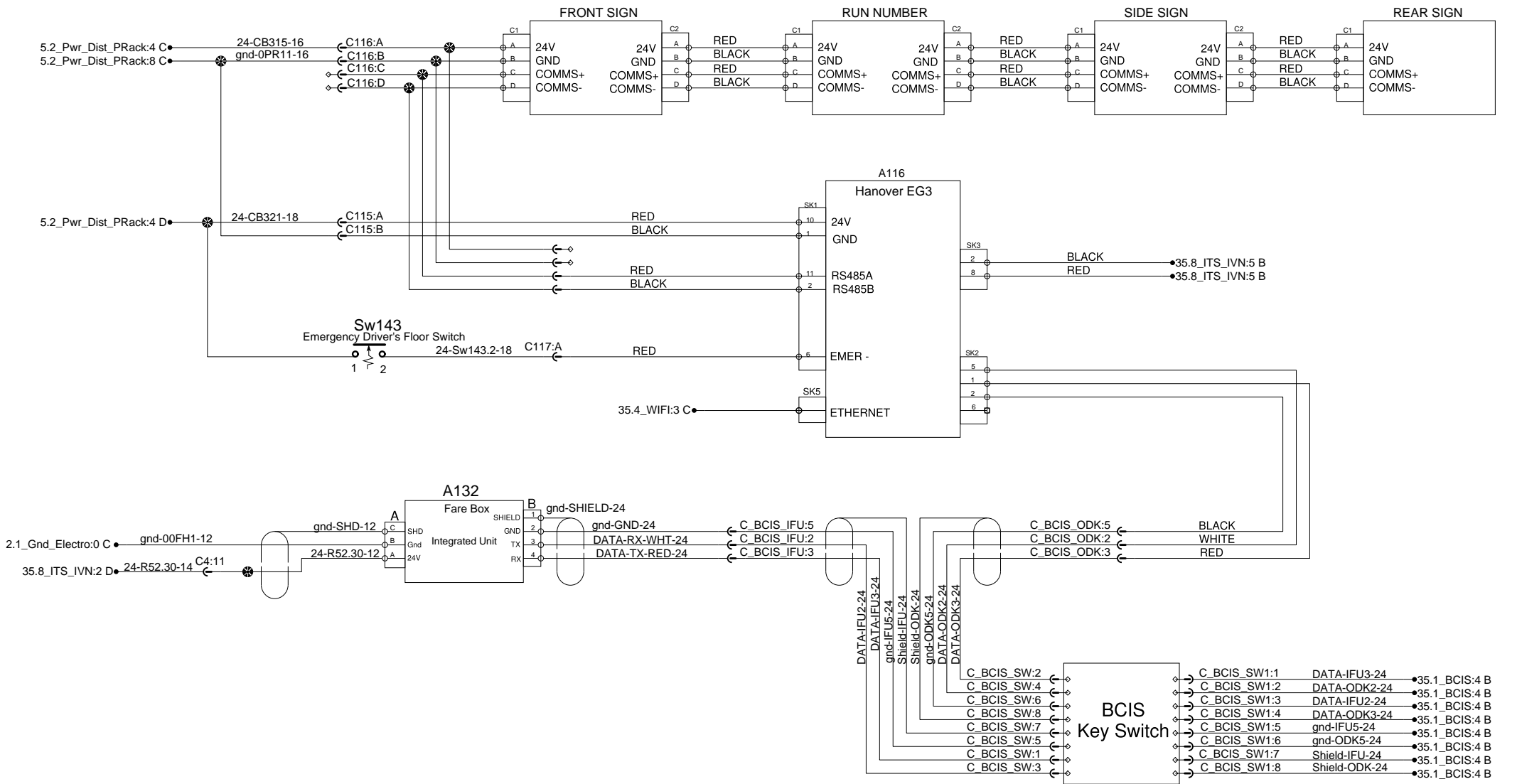

# Destination Sign and Farebox

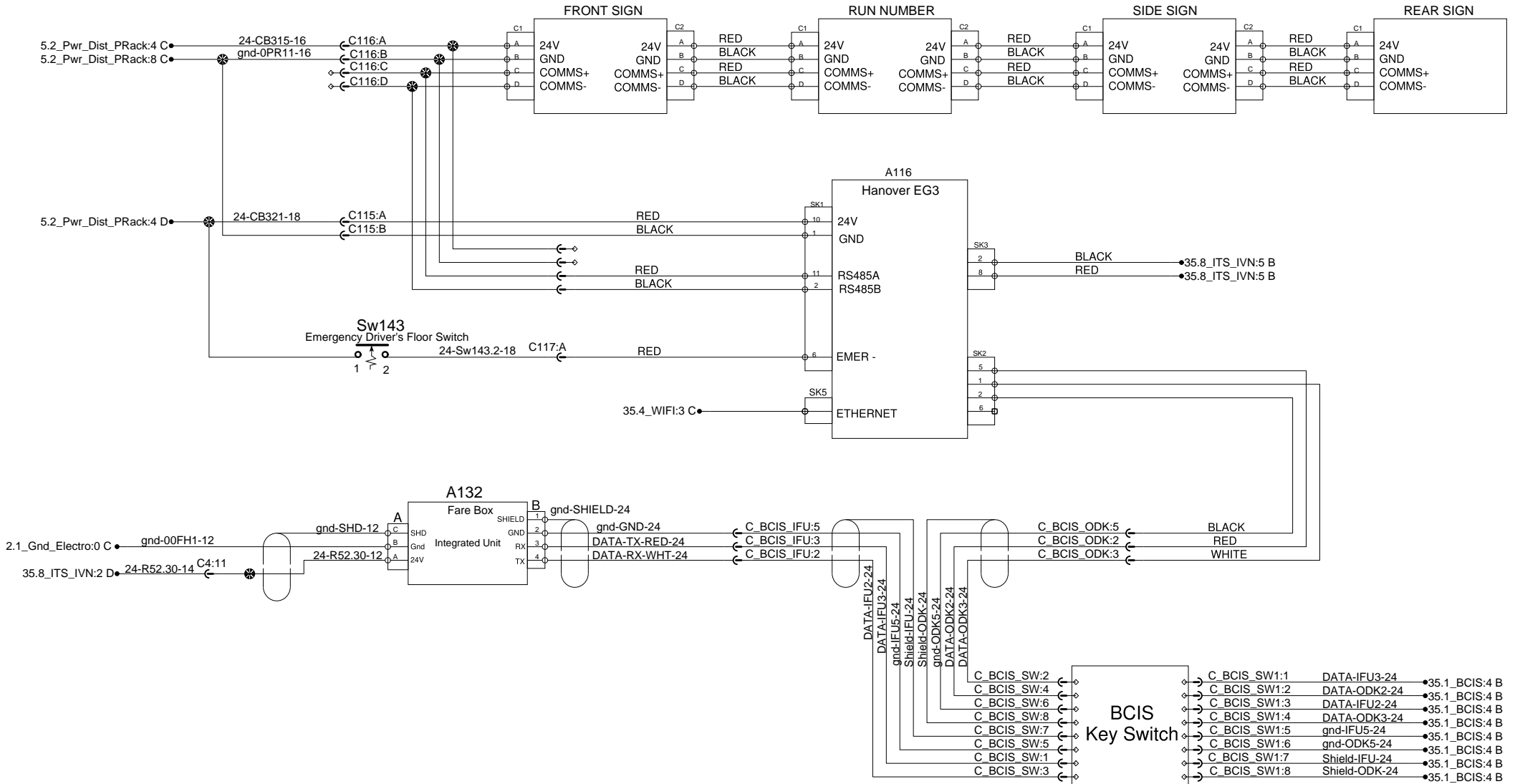

# Entrance door

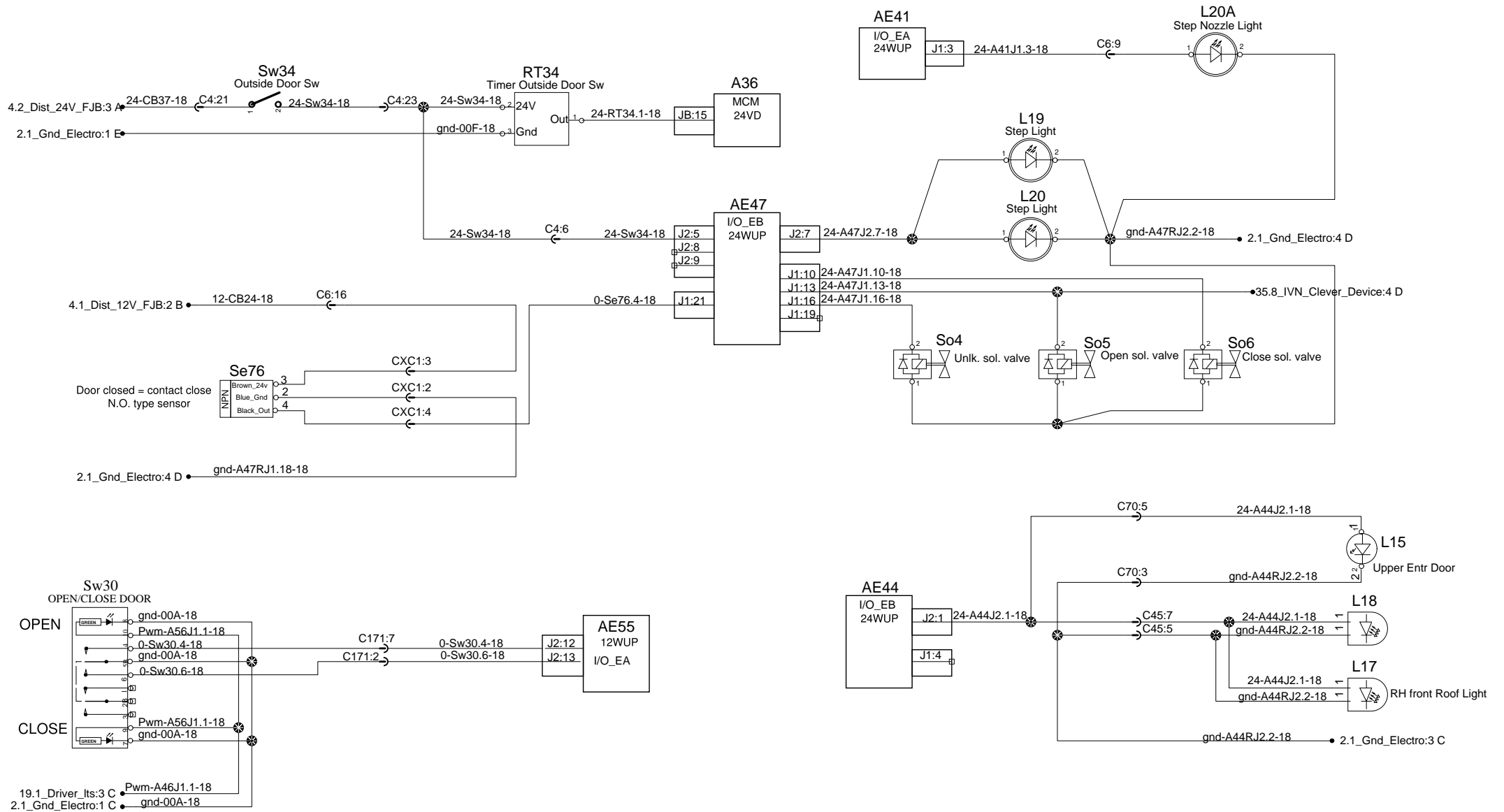

# Entrance door

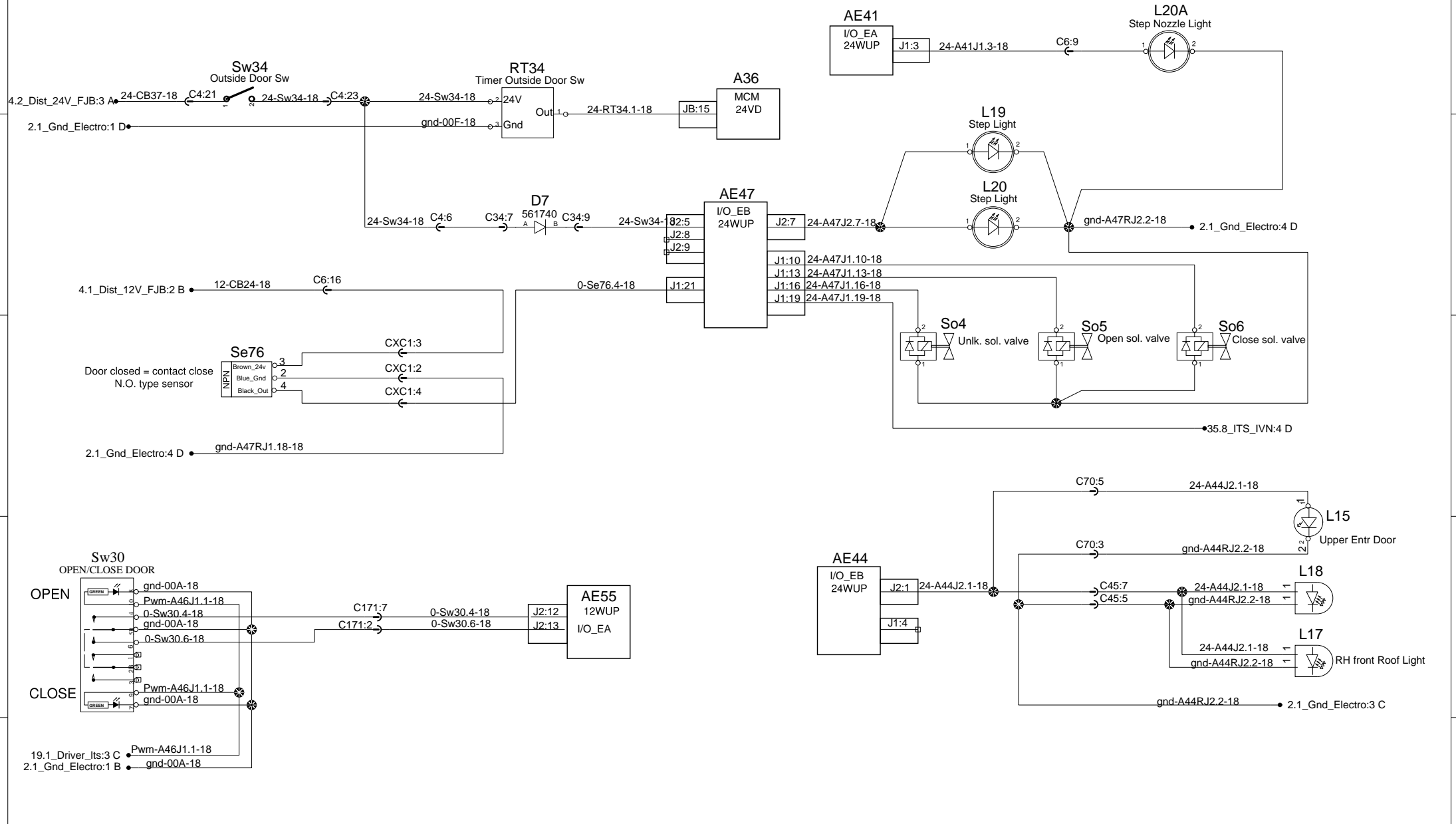

# Driver window

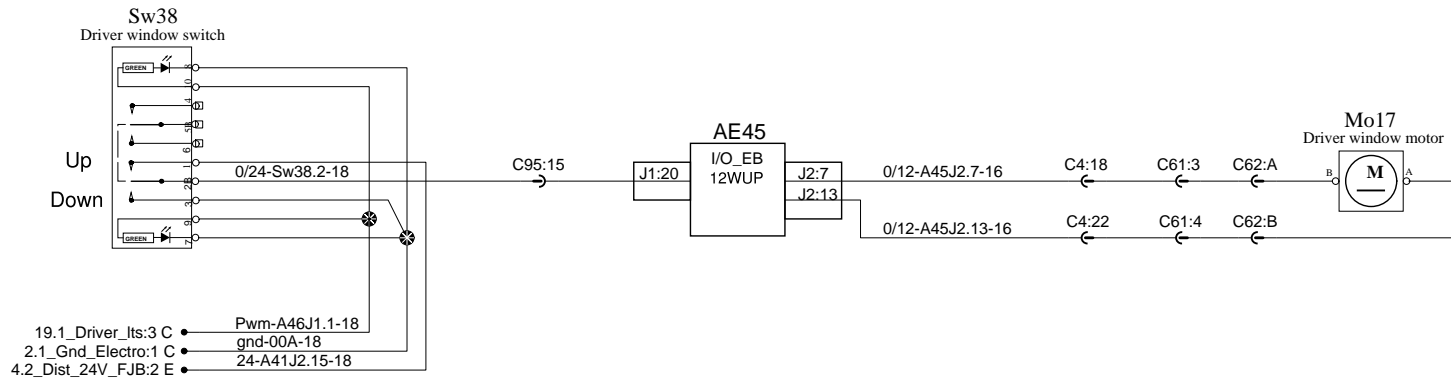

# Mirrors, 2 adjustments and heated

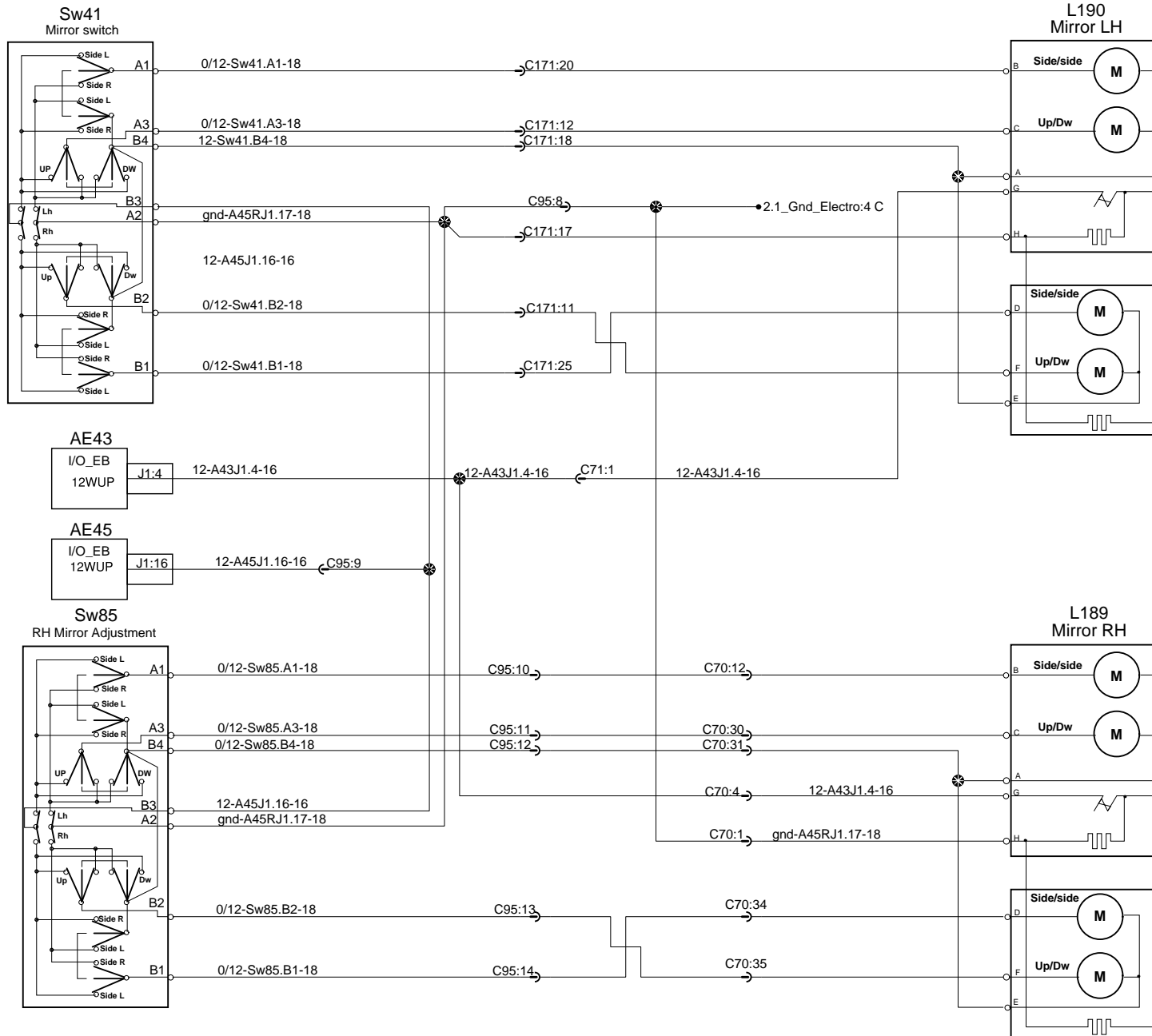



# Kneeling, Tag and Park brake control

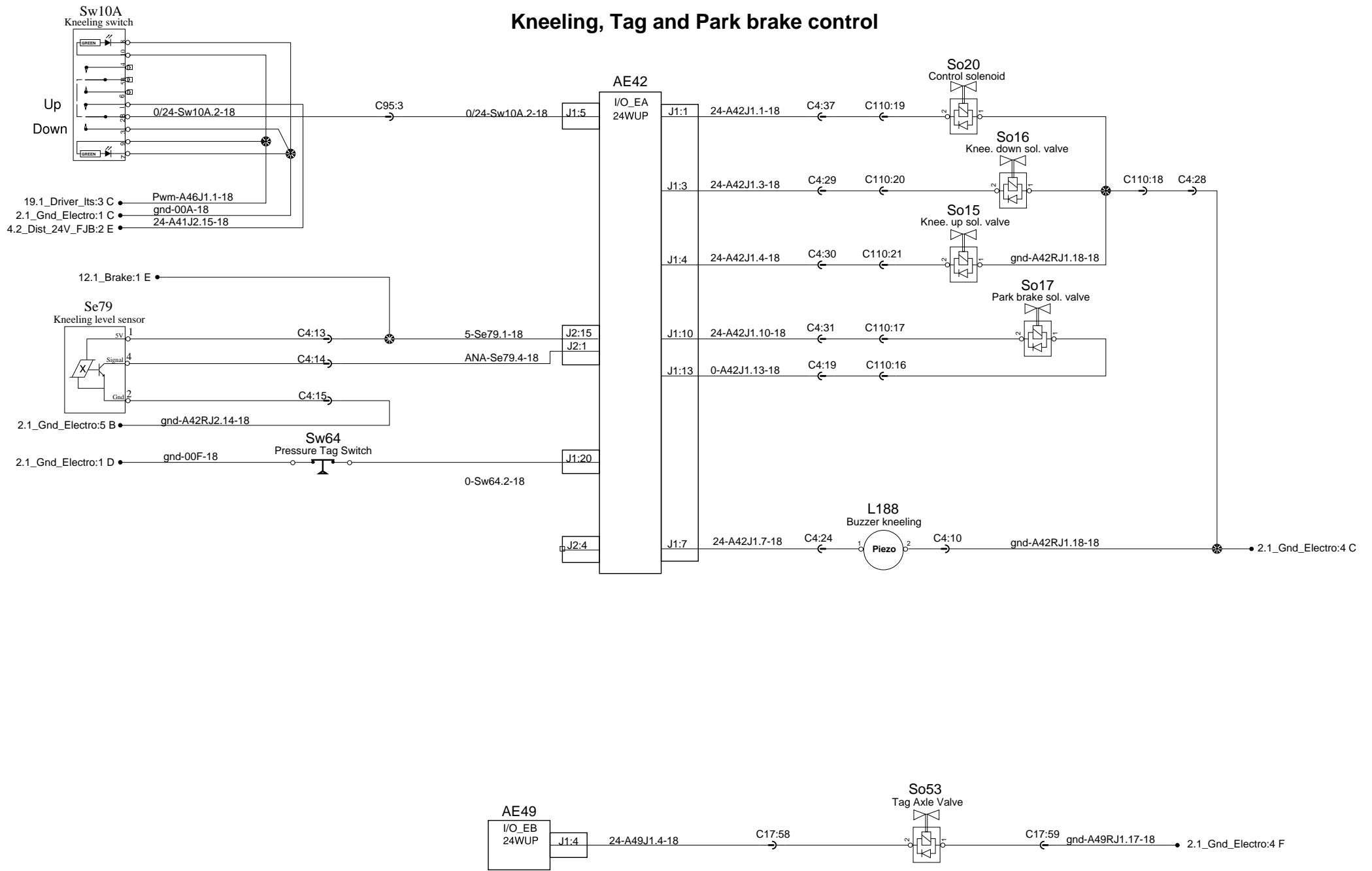

# Kneeling, Tag and Park brake control

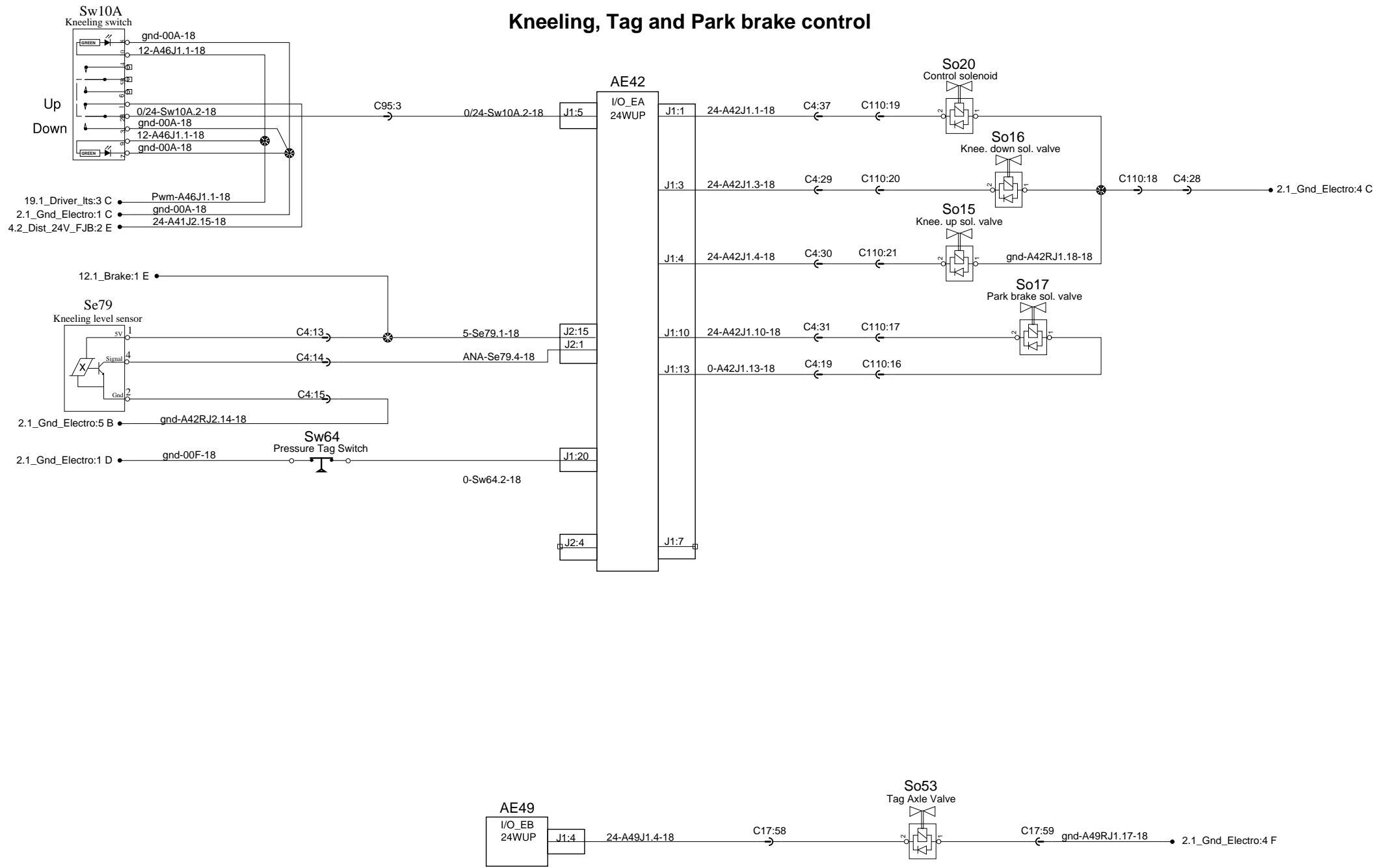

# Wiper and washer

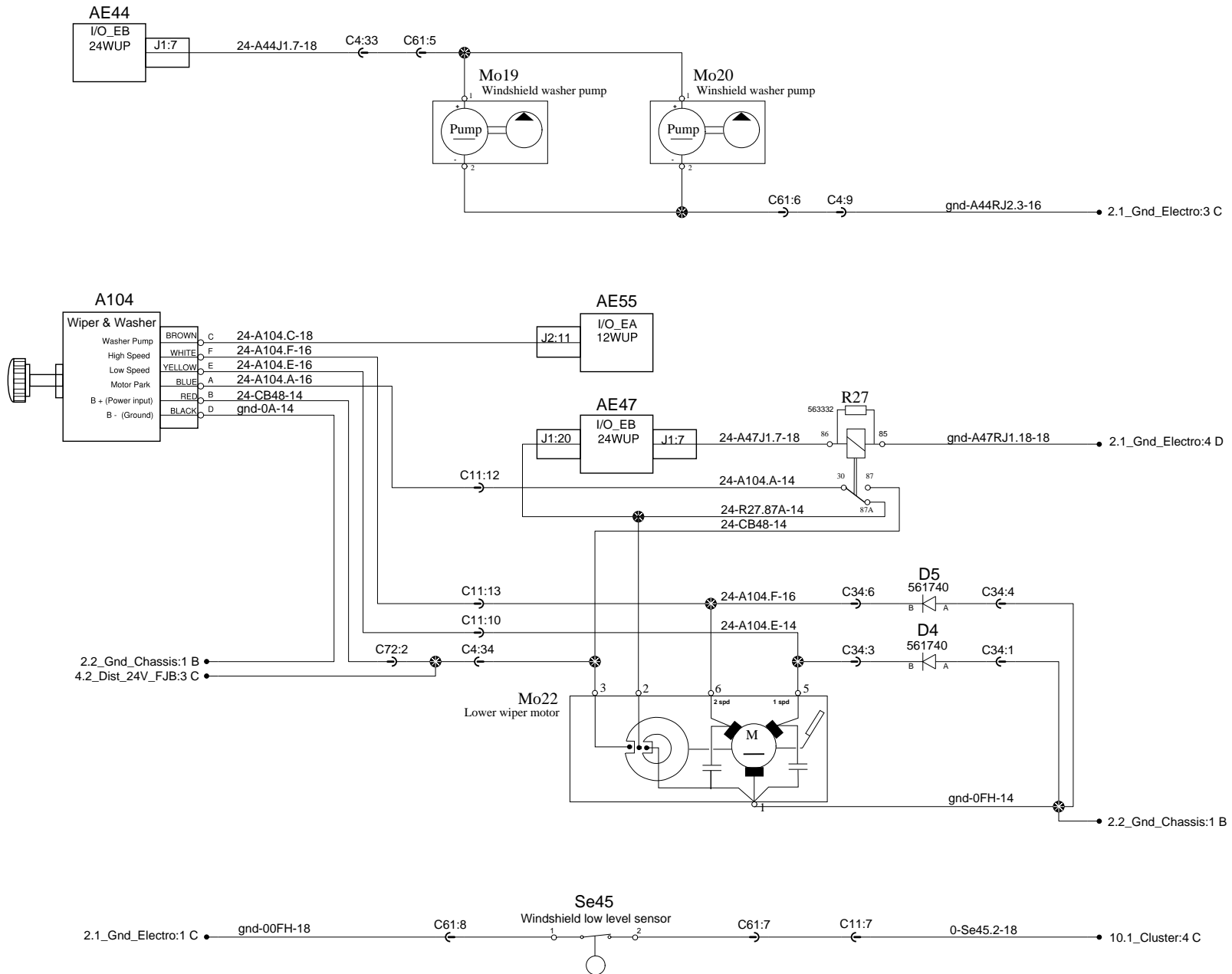

### BCIS

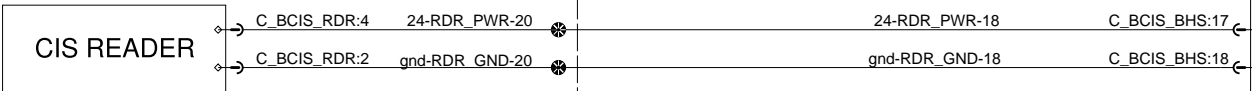
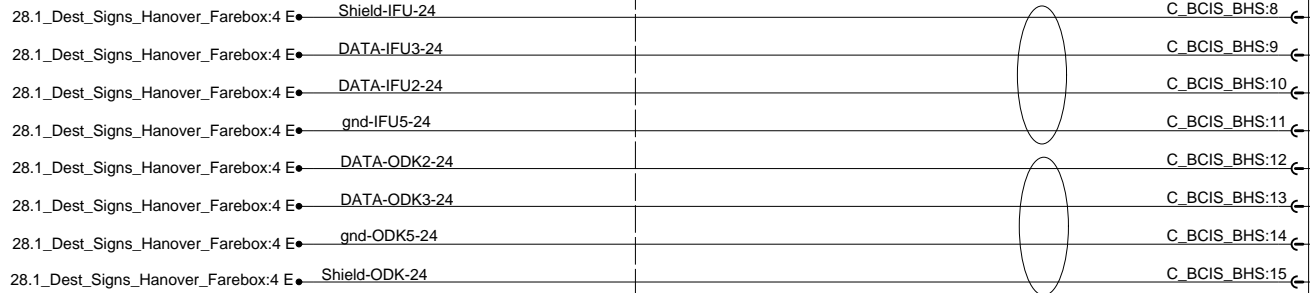
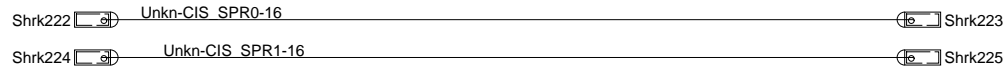
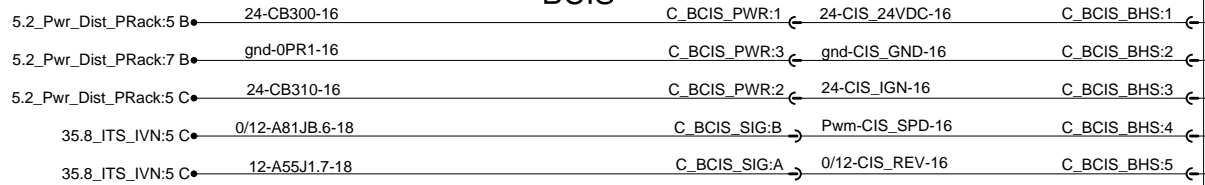

### DASHBOARD AREA

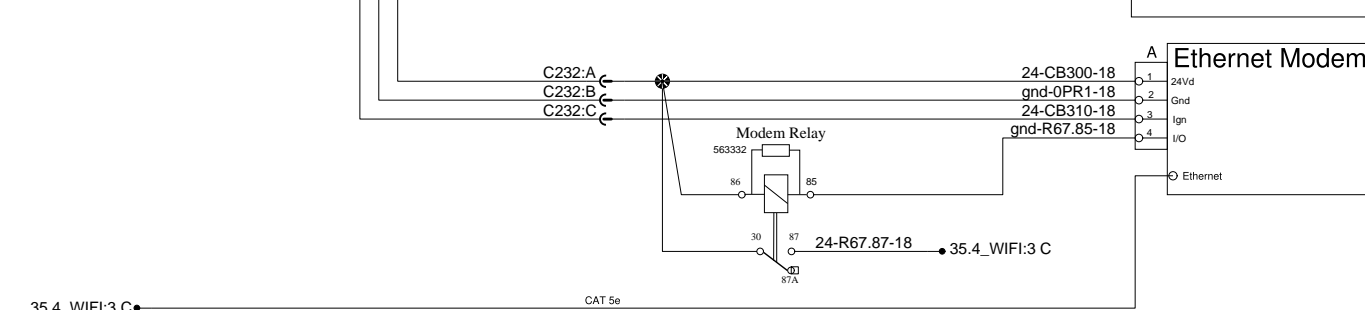
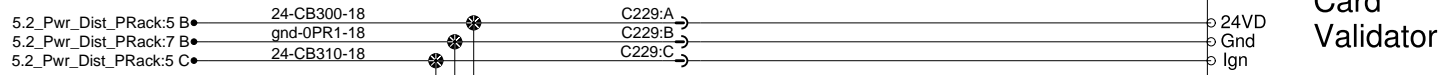
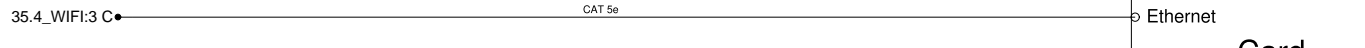
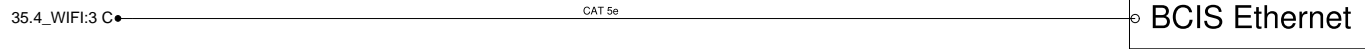

BUS HARDWARE SUBSYSTEM (BHS)

1

2

3

4

5

# BCIS

A

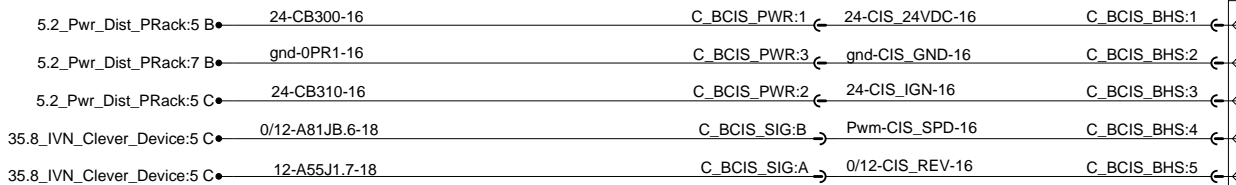

B

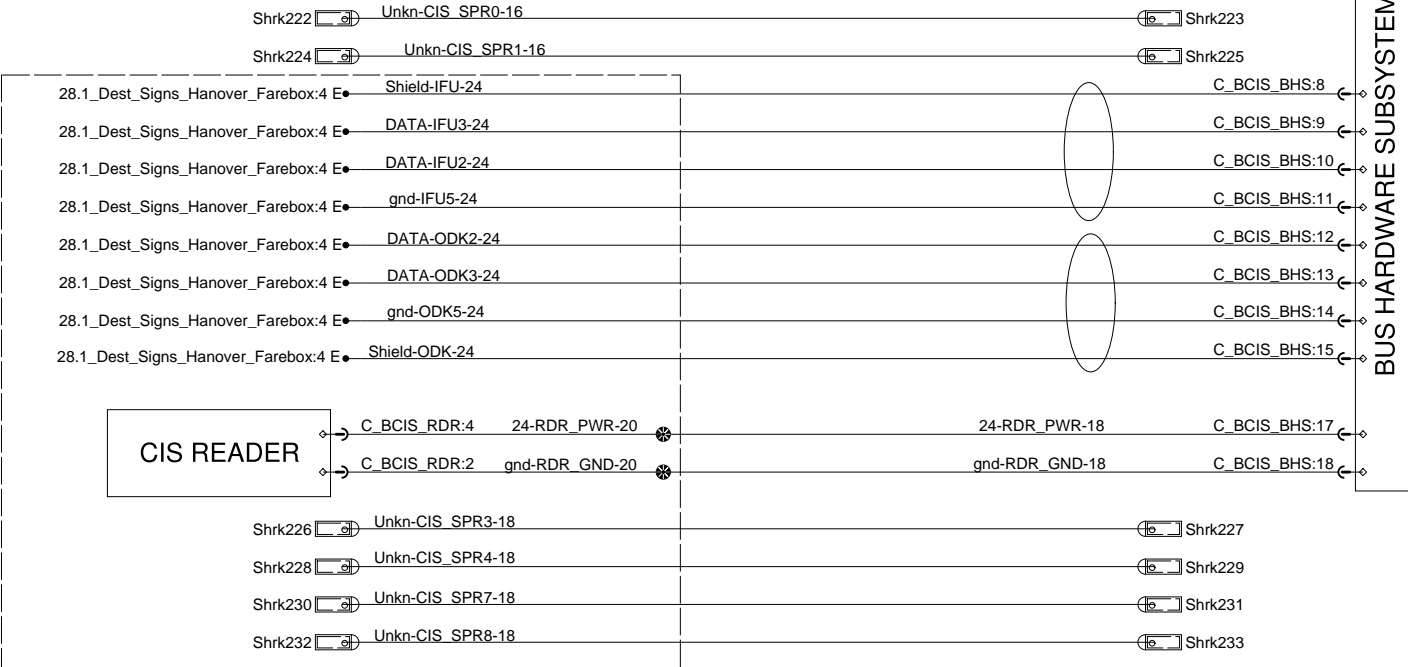

C

CIS READER

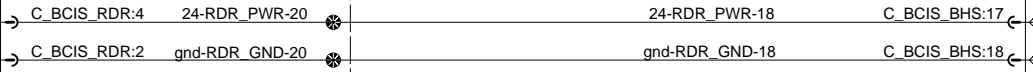

D



E

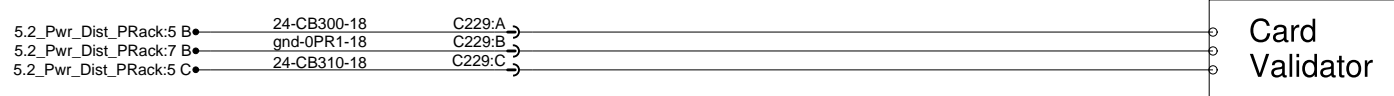

1

2

3

4

5

# Speakers arrangement (Delta configuration)

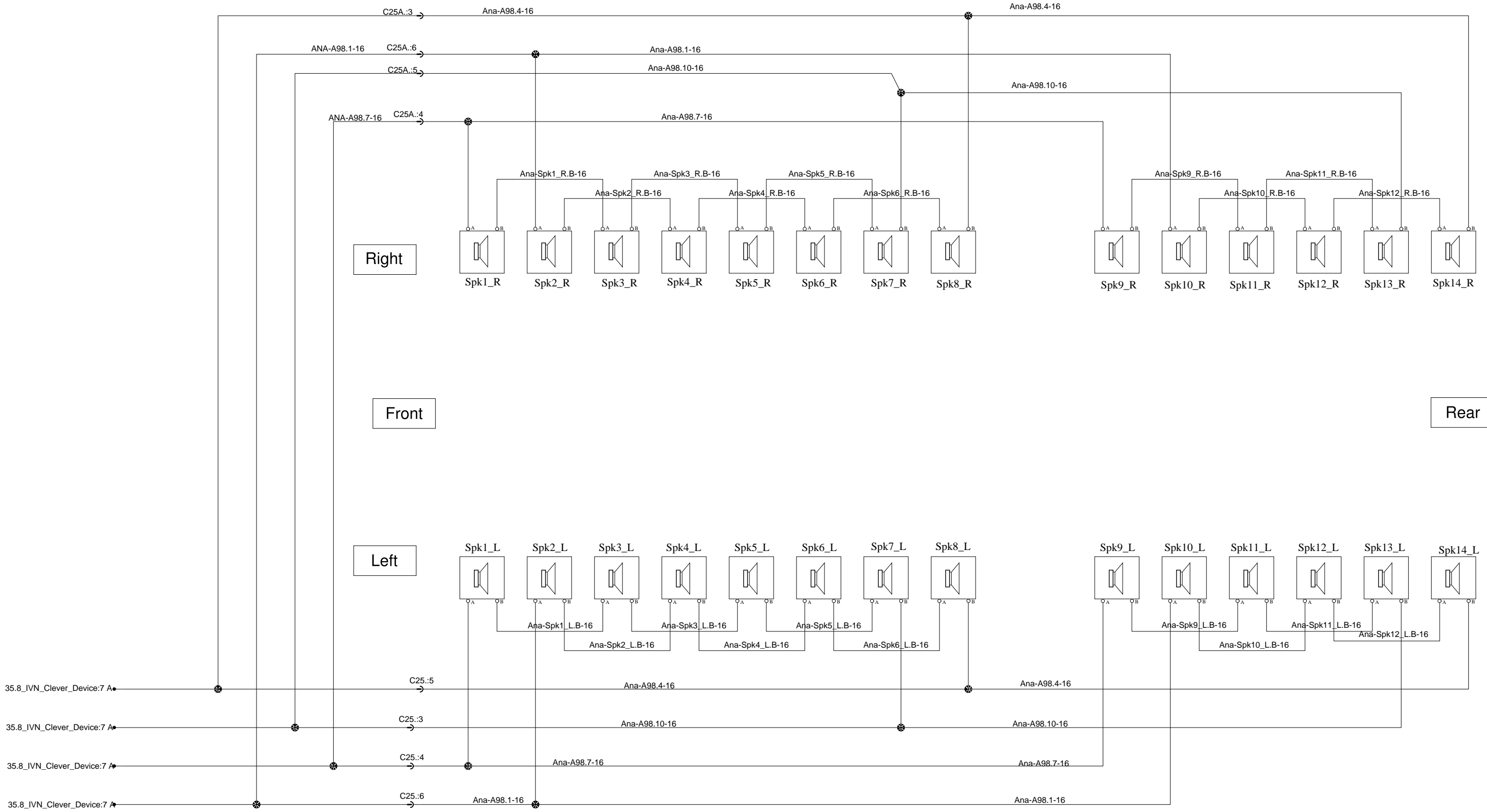

# Infotainment

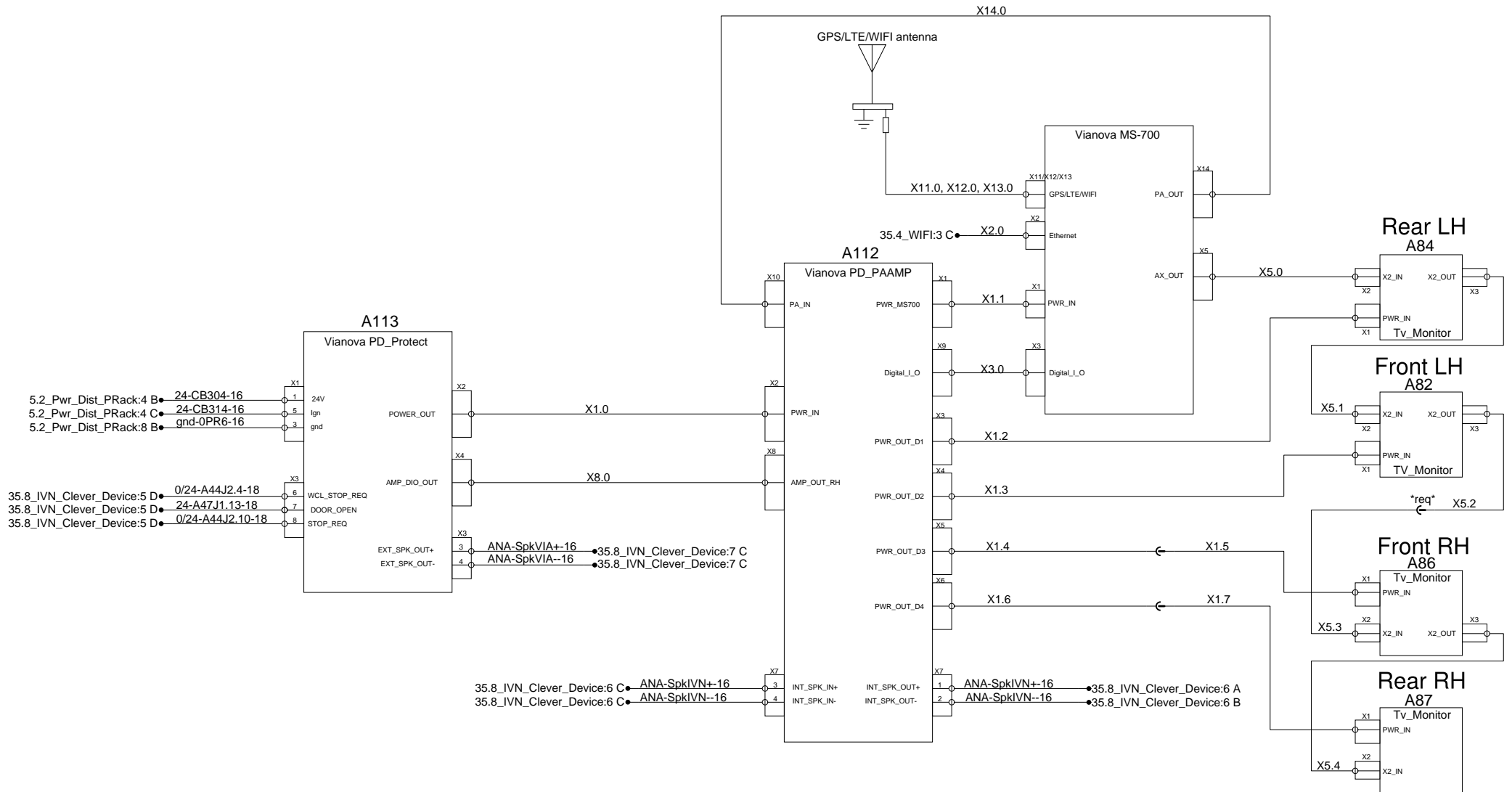

# Infotainment

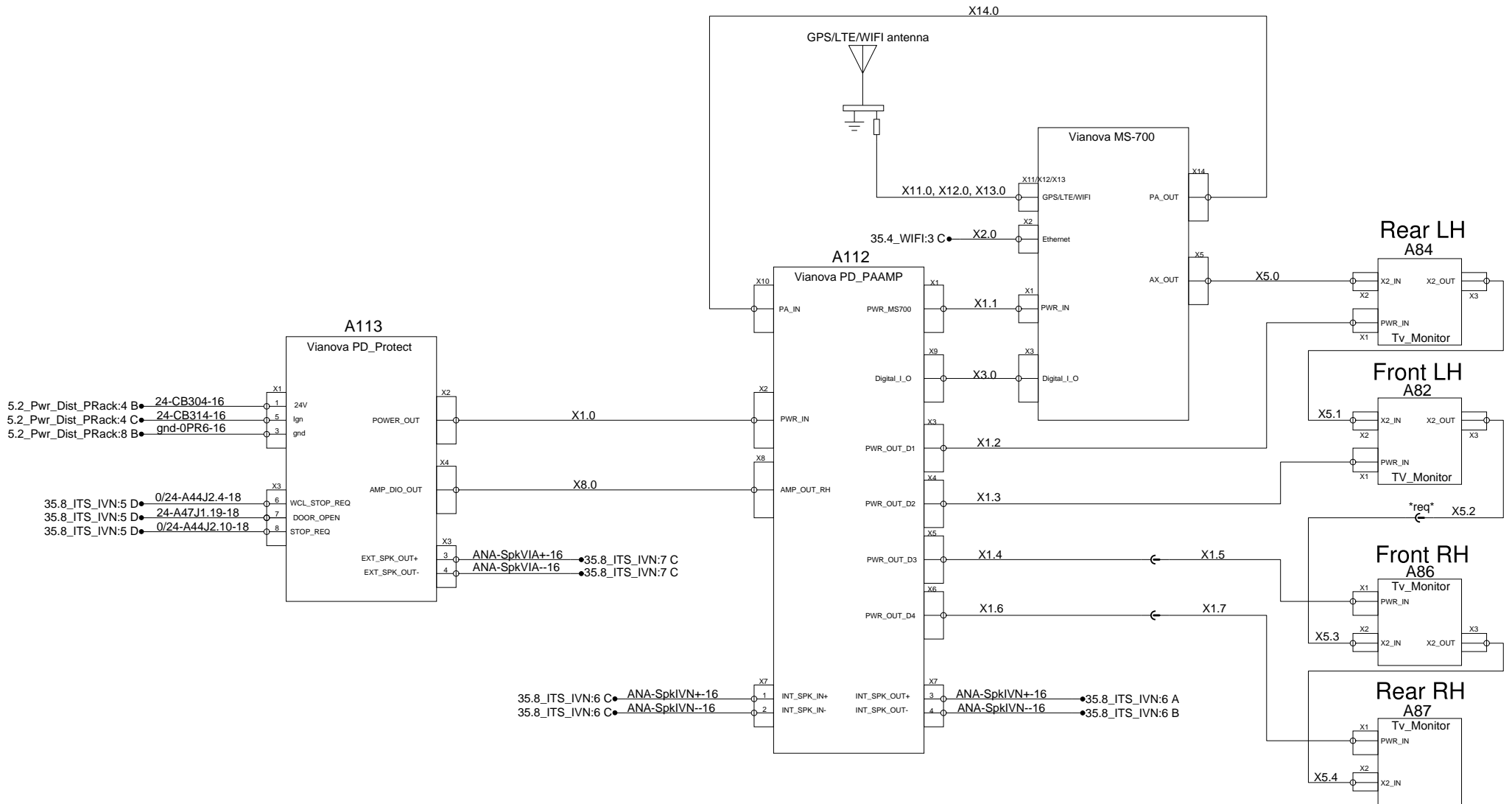



### WIFI

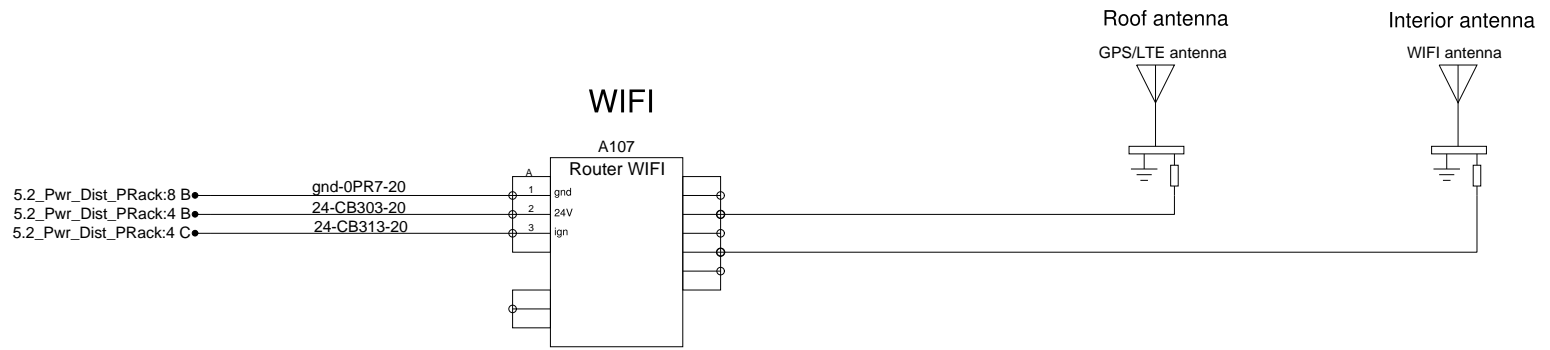

### ETHERNET

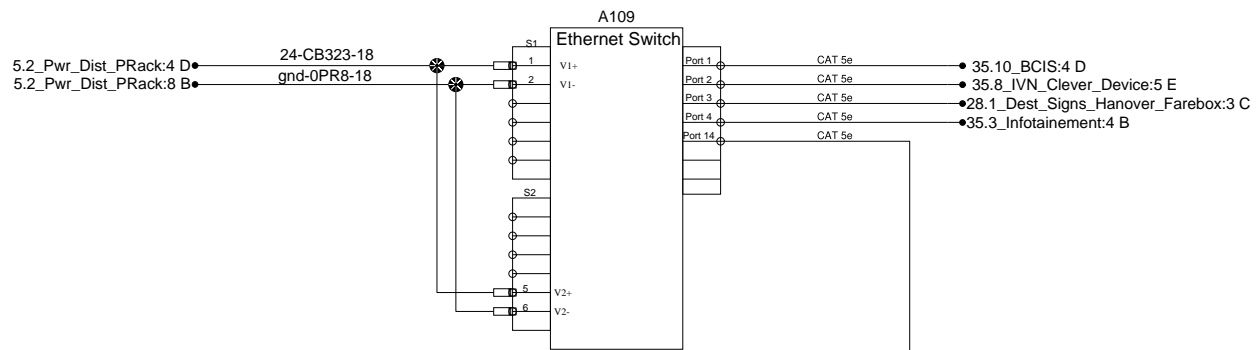

### AUTOMATIC PASSENGER COUNTING

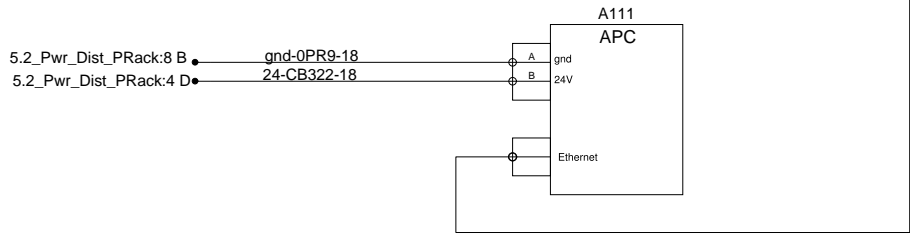

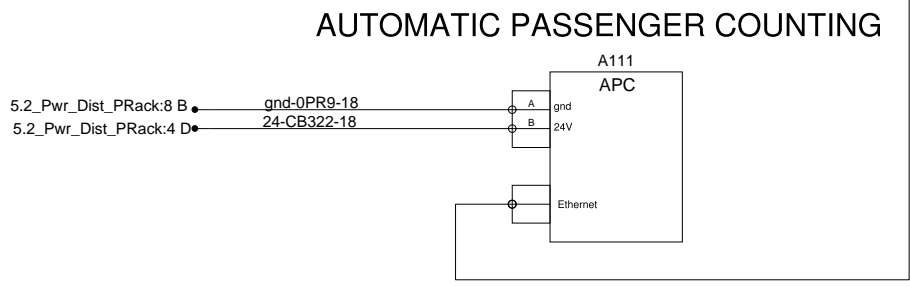
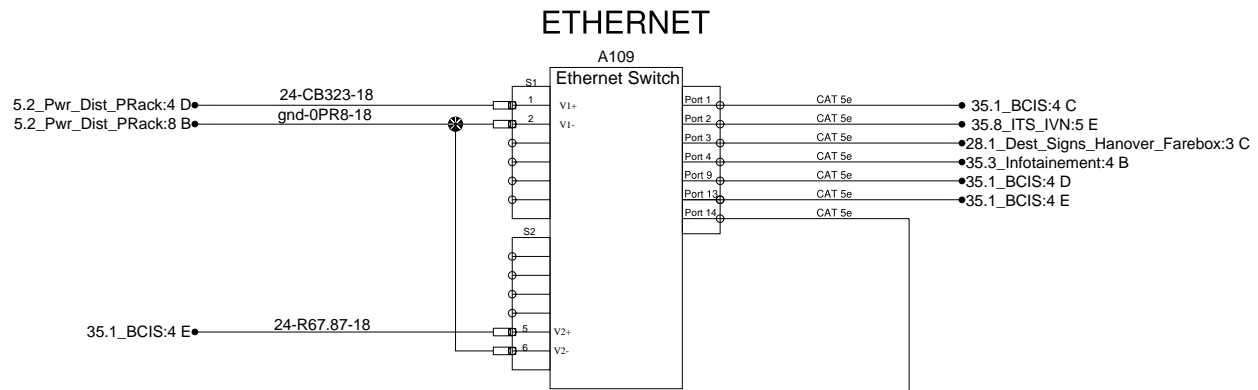
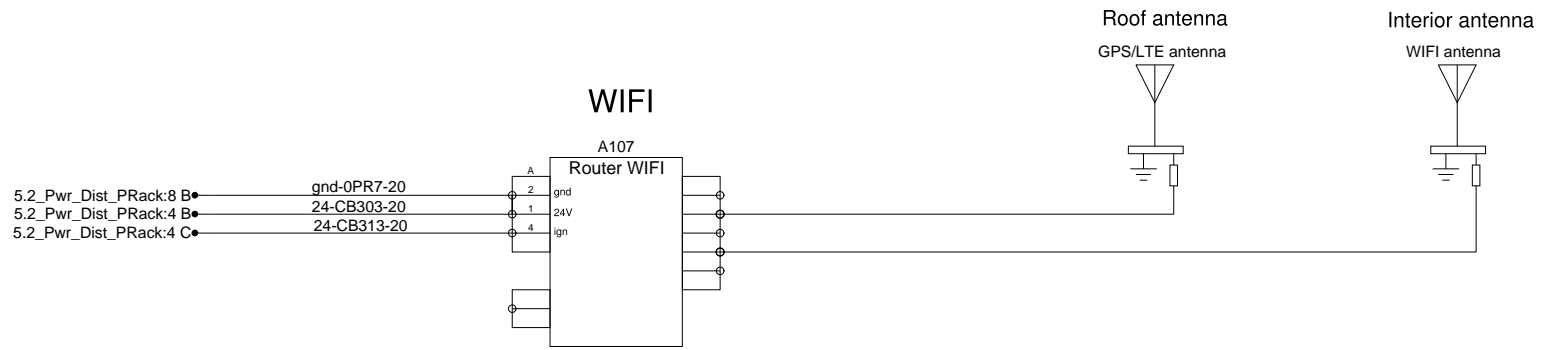

# GONG SOUND GENERATOR

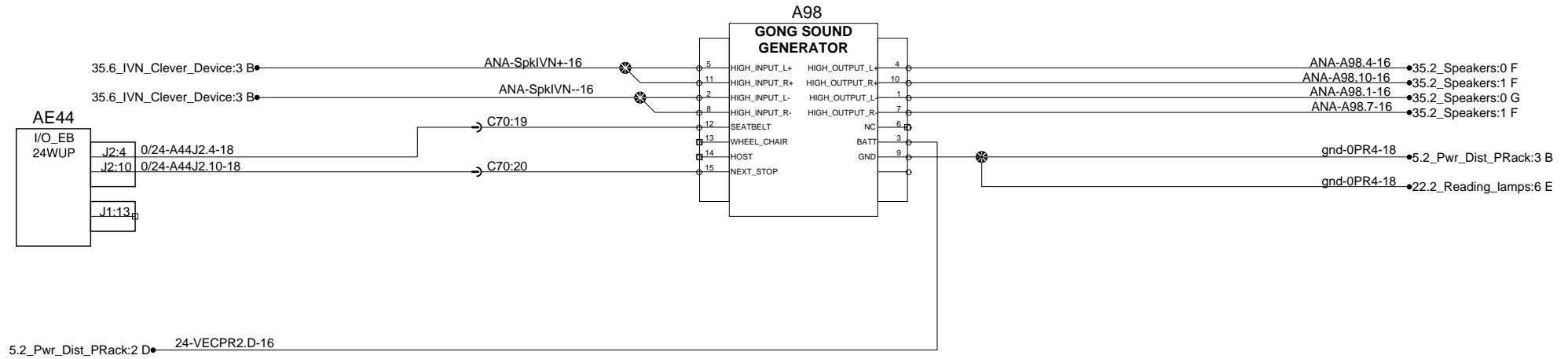

# MOBILEVIEW

5.2\_Pwr\_Dist\_PRRack:4 B ● 24-CB301-16 ● C\_MVIEW:1  
 5.2\_Pwr\_Dist\_PRRack:8 B ● gnd-0PR2-16 ● C\_MVIEW:2  
 5.2\_Pwr\_Dist\_PRRack:5 C ● 24-CB311-16 ● C\_MVIEW:3

## DVR ACCESSORIES

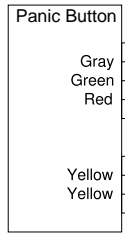
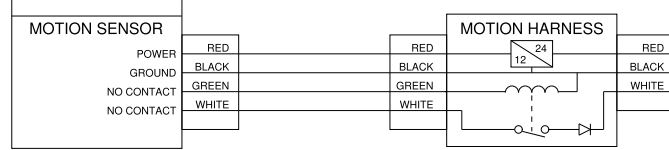

12.1\_Brake:3 C ● 24-A36JA.25-18 ● C70B:8 ● Brake Application ● C\_MVIEW:10  
 36.1\_WCL\_Ricon:5 C ● C59:4 ● 24-A57J1.3-18 ● C2:30 ● C70B:9 ● WCL Door Open ● C\_MVIEW:6  
 35.8\_IVN\_Clever\_Device:5 C ● 24-A55J1.7-18 ● C70B:10 ● Reverse ● C\_MVIEW:11  
 7.1\_Mux\_Power:2 B ● 24-A41J1.13-18 ● C70B:2 ● Engine Run ● C\_MVIEW:7  
 36.1\_WCL\_Ricon:5 C ● C59:7 ● 24-A57J1.1-18 ● C2:24 ● C70B:10 ● WCL Activation ● C\_MVIEW:12  
 35.8\_IVN\_Clever\_Device:5 D ● 24-A47J1.13-18 ● C\_MVIEW:5 ● Front Door Open ● C\_MVIEW:5

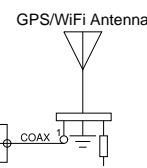
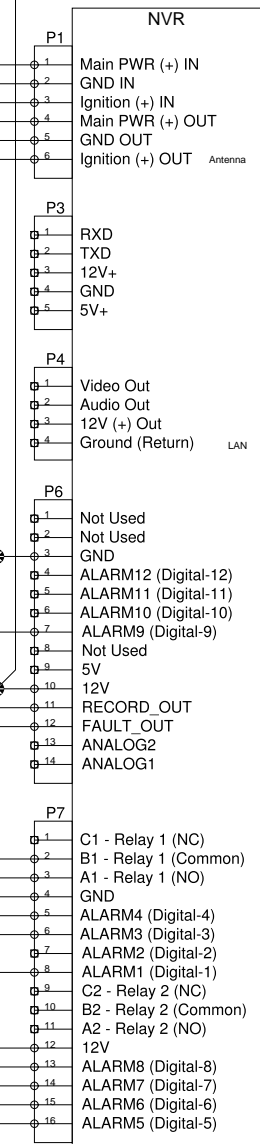

5.2\_Pwr\_Dist\_PRRack:5 C ● 24-CB311-18 ● C230:1  
 5.2\_Pwr\_Dist\_PRRack:8 B ● gnd-0PR3-18 ● C230:2  
 35.8\_IVN\_Clever\_Device:5 C ● 12-A55J1.7-18 ● C230:3

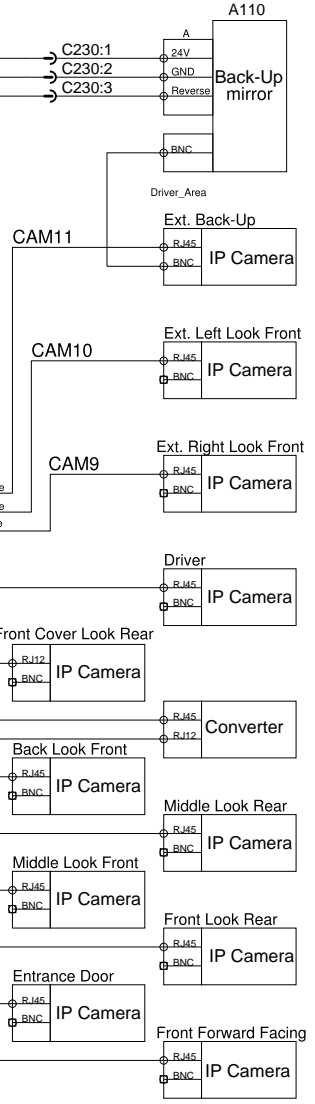
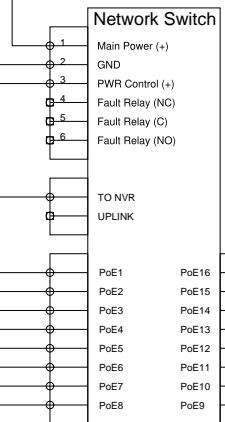

# CAMERA SAFE FLEET

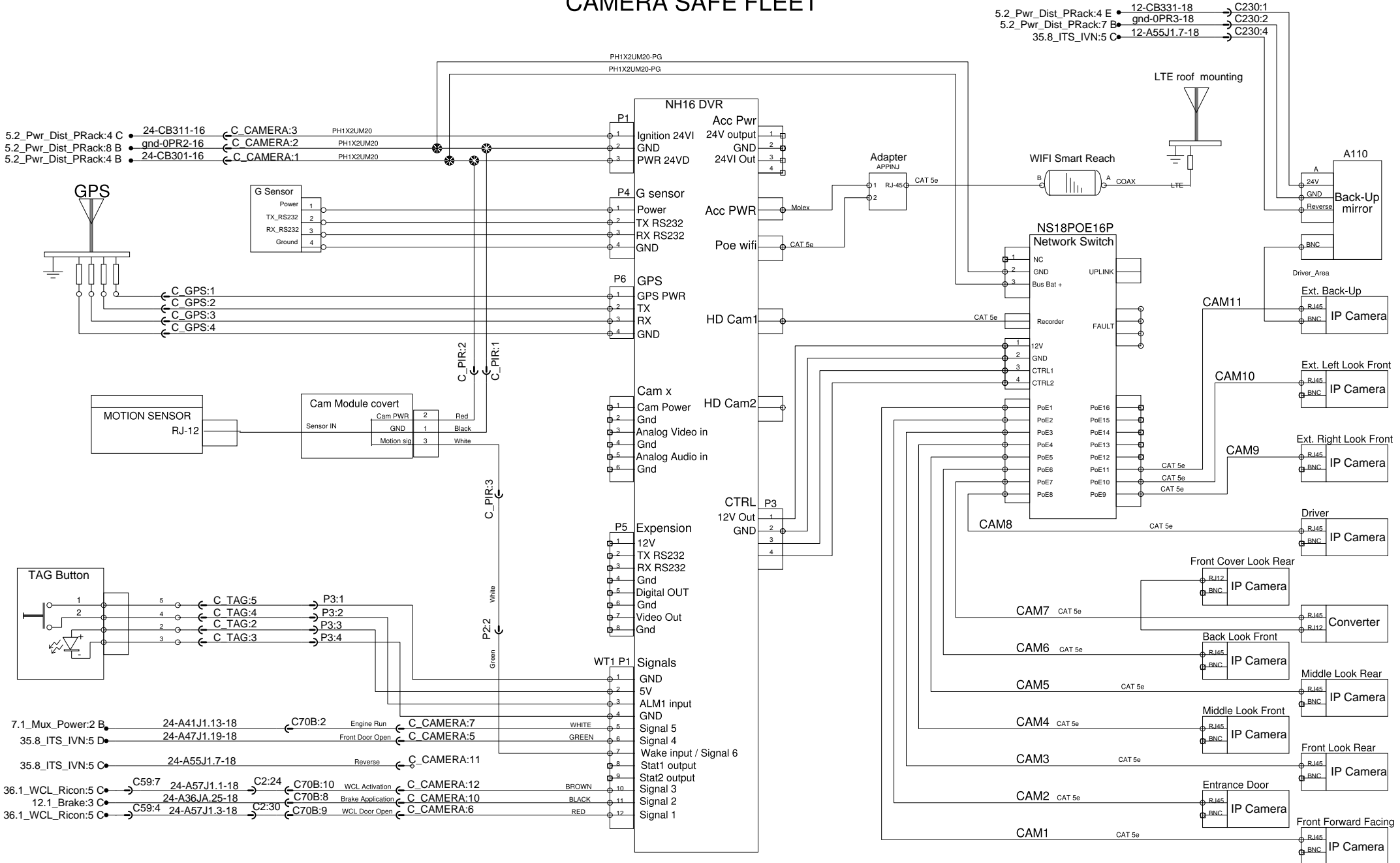

# IVN (Clever Devices)

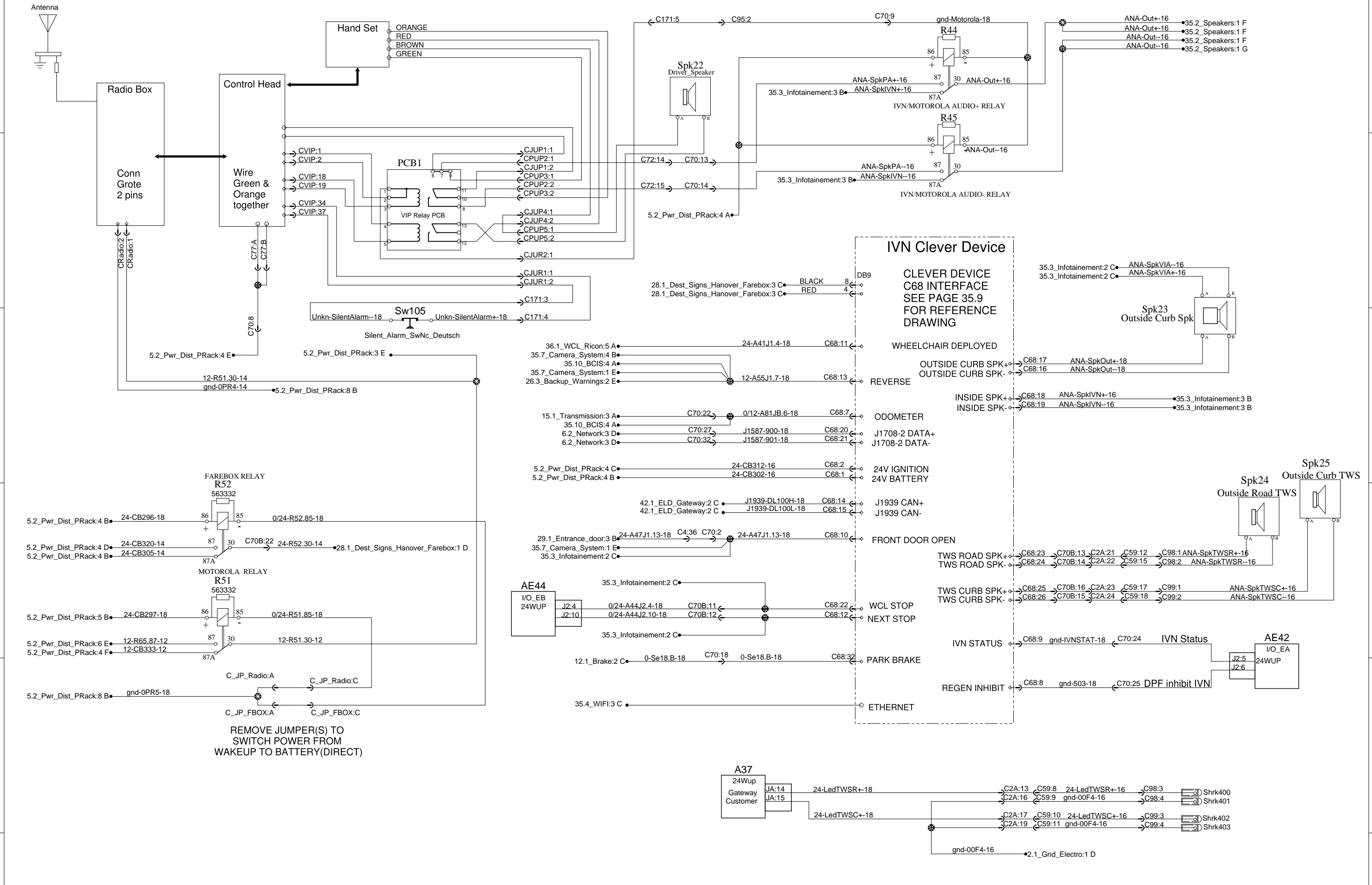

REMOVE JUMPER(S) TO SWITCH POWER FROM WAKEUP TO BATTERY(DIRECT)

# ITS\_IVN

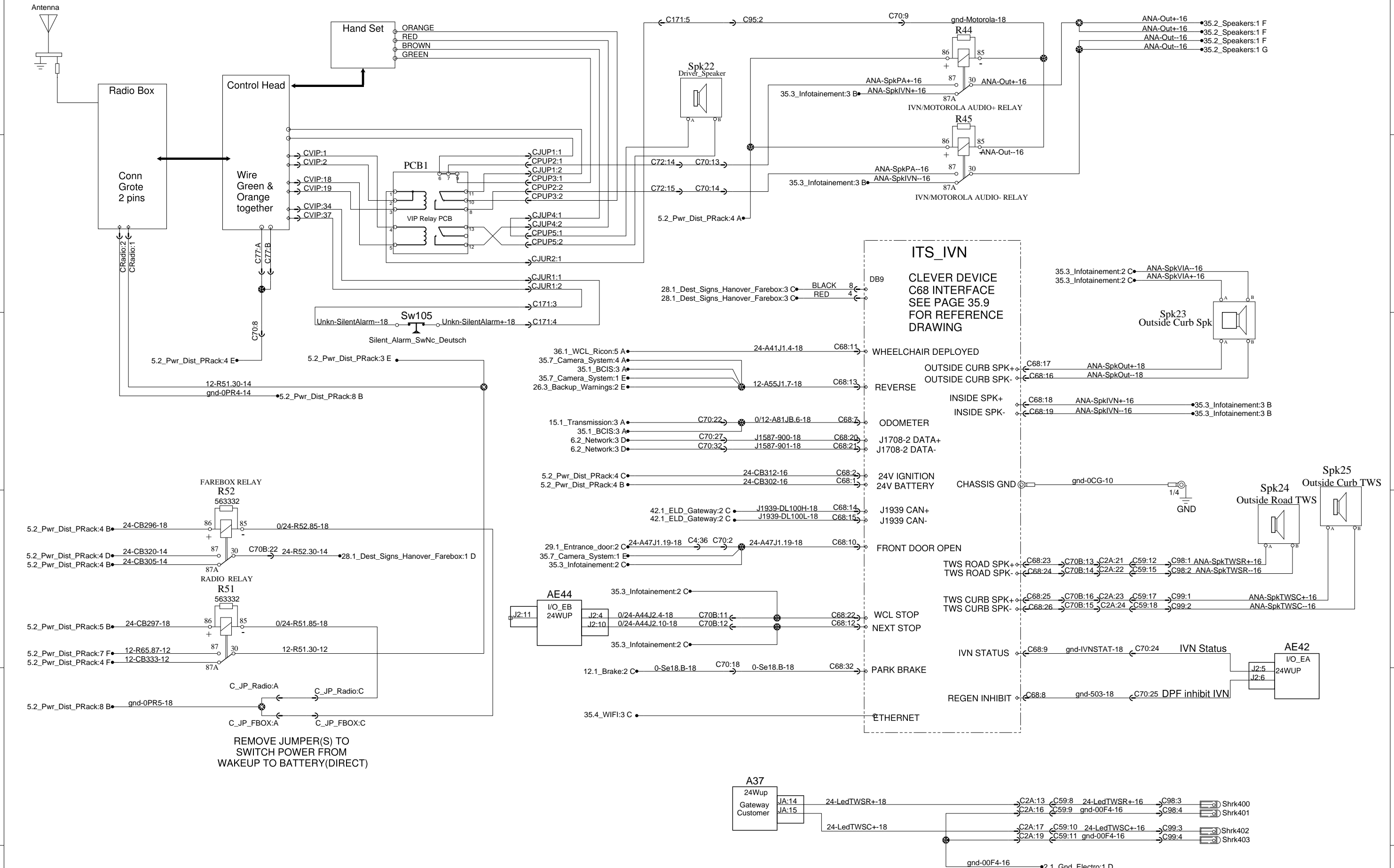

# ITS\_IVN

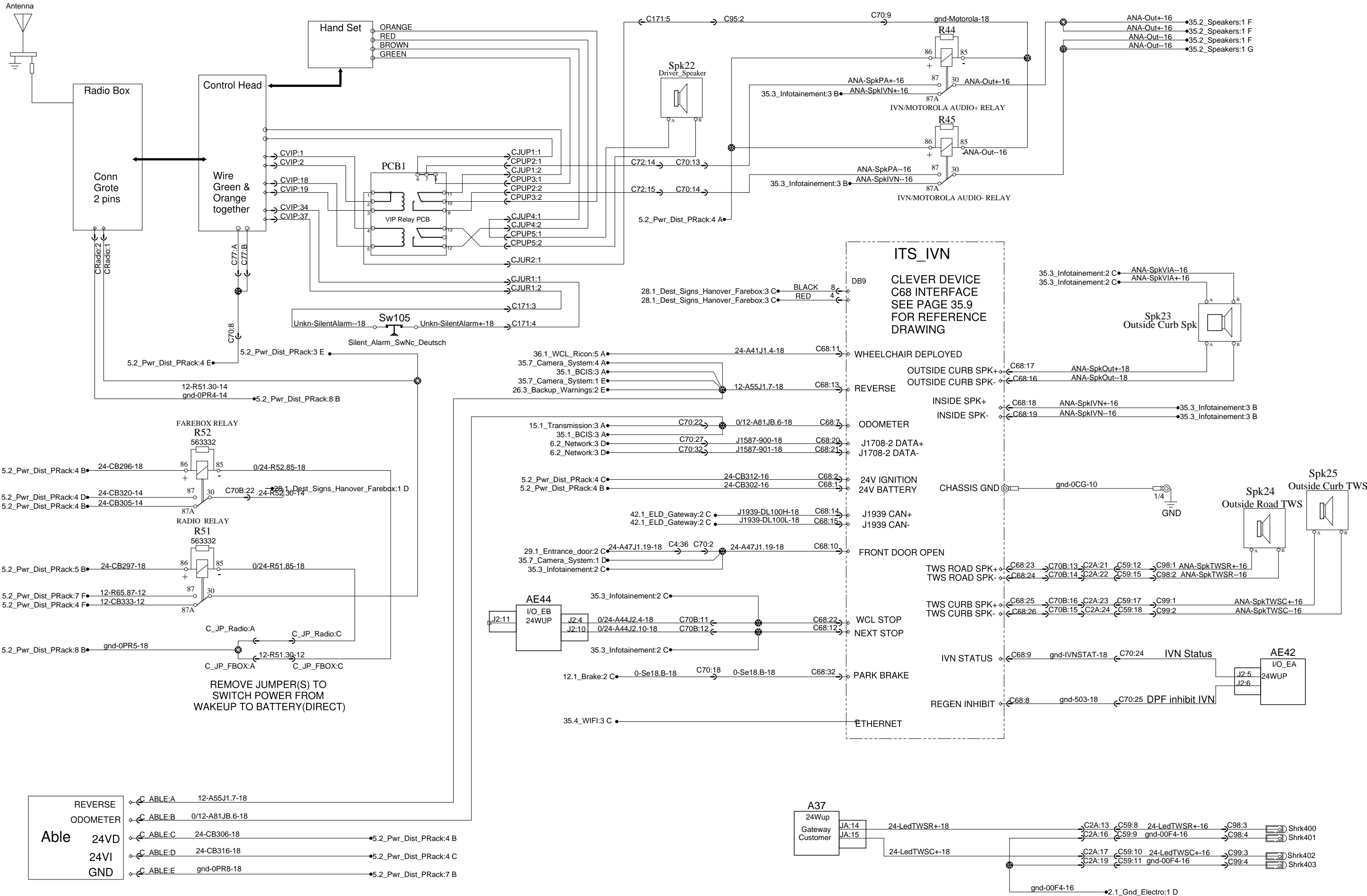

REVERSE	ABLE:A	12-A55J1.7-18	
ODOMETER	ABLE:B	0/12-A81JB.6-18	
Able 24VD	ABLE:C	24-CB306-18	5.2_Pwr_Dist_PRRack:4 B
24VI	ABLE:D	24-CB316-18	5.2_Pwr_Dist_PRRack:4 C
GND	ABLE:E	gnd-0PR8-18	5.2_Pwr_Dist_PRRack:7 B



# ITS\_IVN

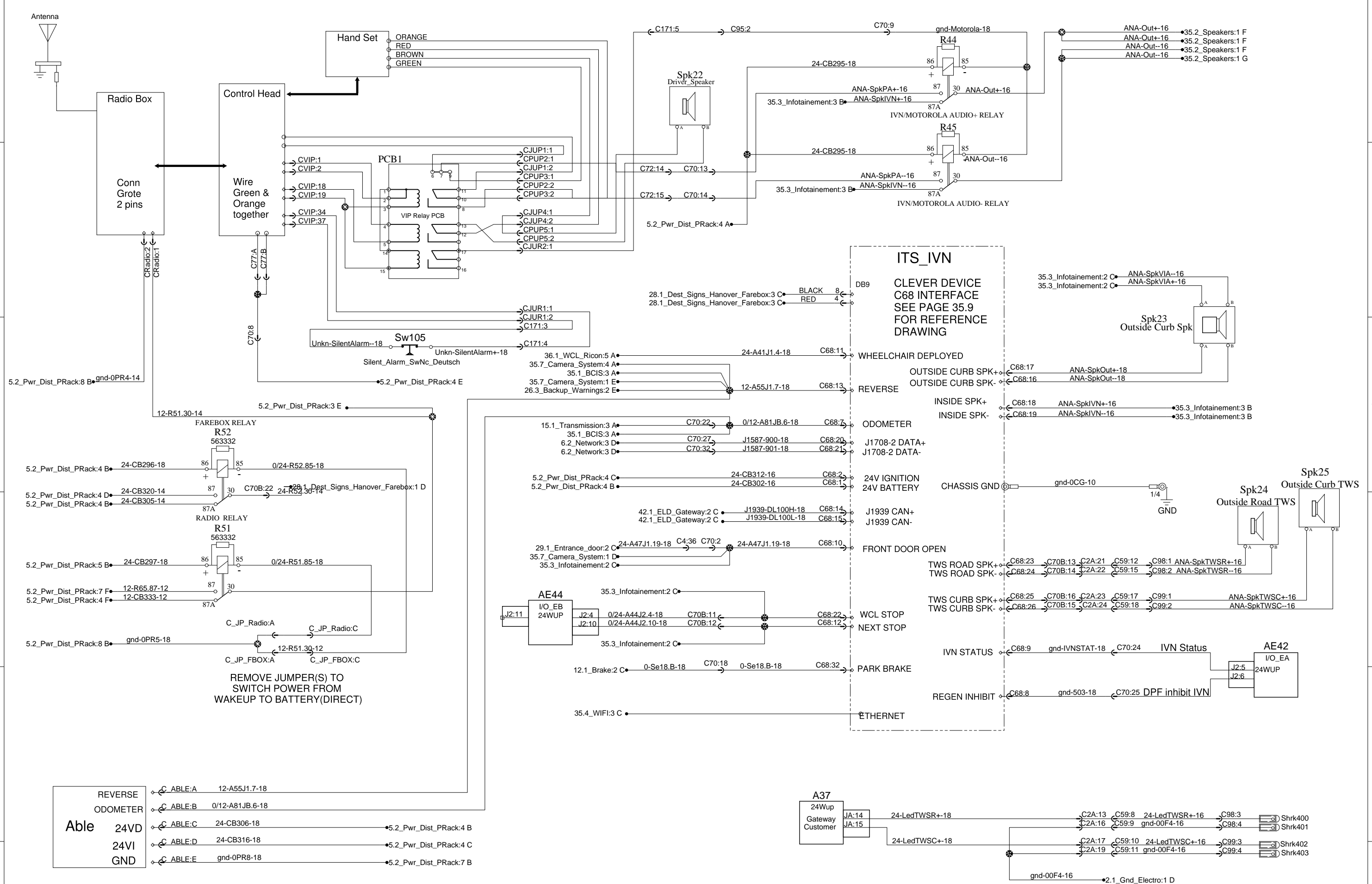

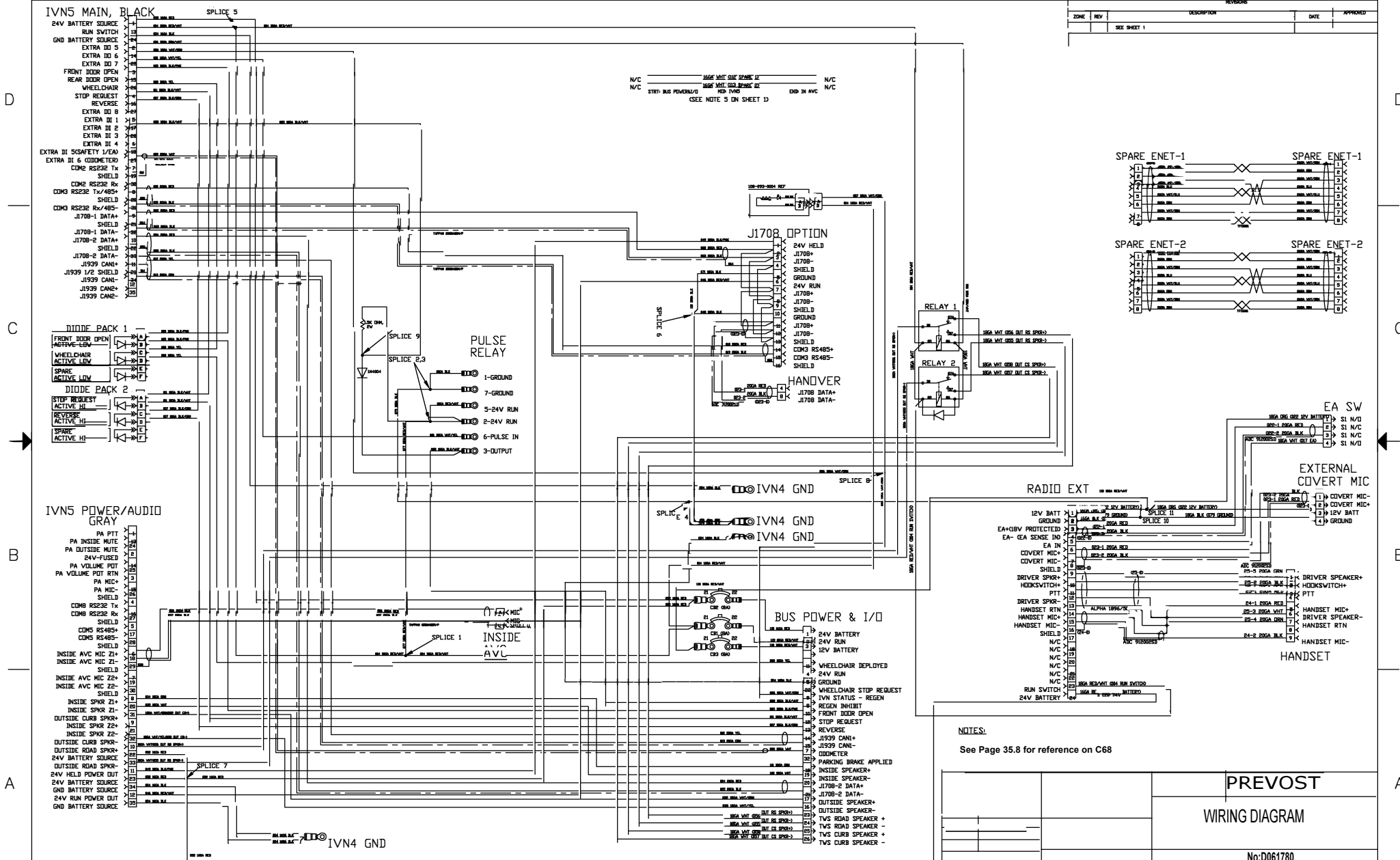

ZONE	REV	DESCRIPTION	DATE	APPROVED
	SEE SHEET 1			

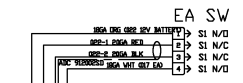
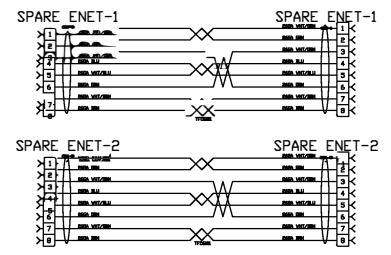

**PREVOST**

**WIRING DIAGRAM**

No: D061780

Page: 35.9

Rev 3

THIS DRAWING IN DIMENSION & DETAIL IS THE PROPERTY OF CLEVER TECHNOLOGY LTD. & MUST NOT BE USED EXCEPT IN CONNECTION WITH OUR WORK. ALL RIGHTS OF DESIGN OR INVENTION ARE RESERVED.

# Wheel chair lift Ricon 9000

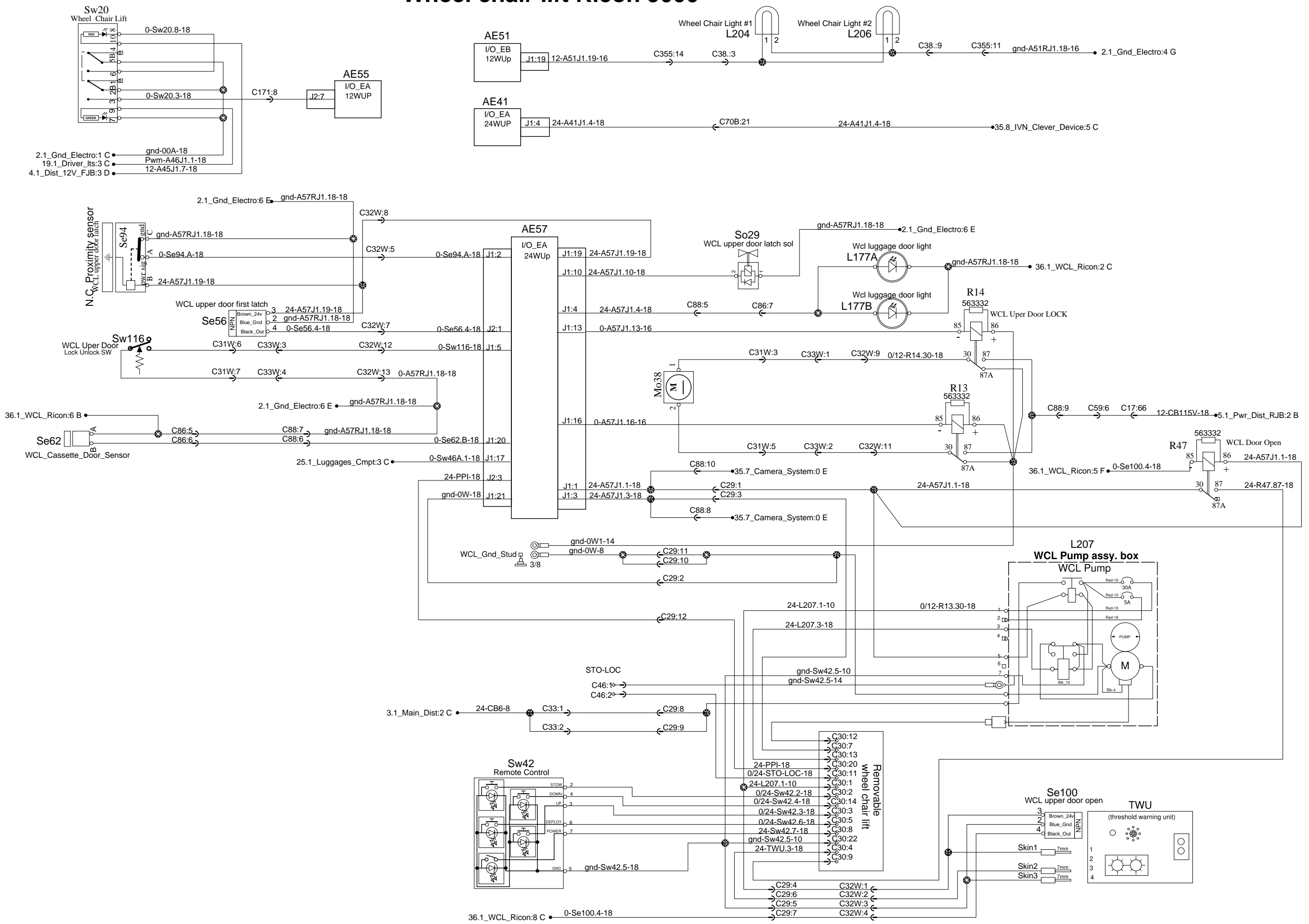

# Wheel chair lift Ricon 9000

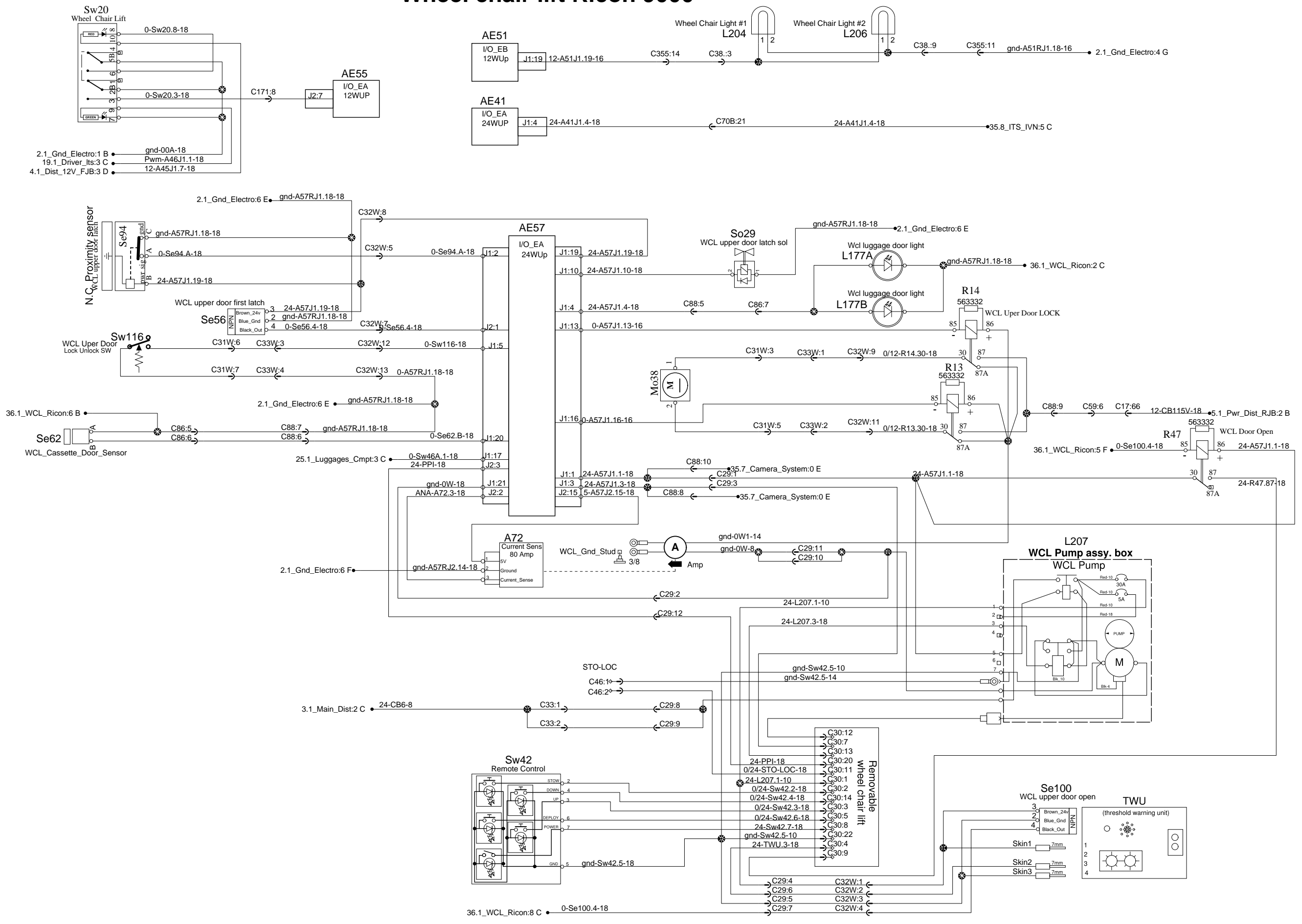

# Wheel chair lift Ricon 9000

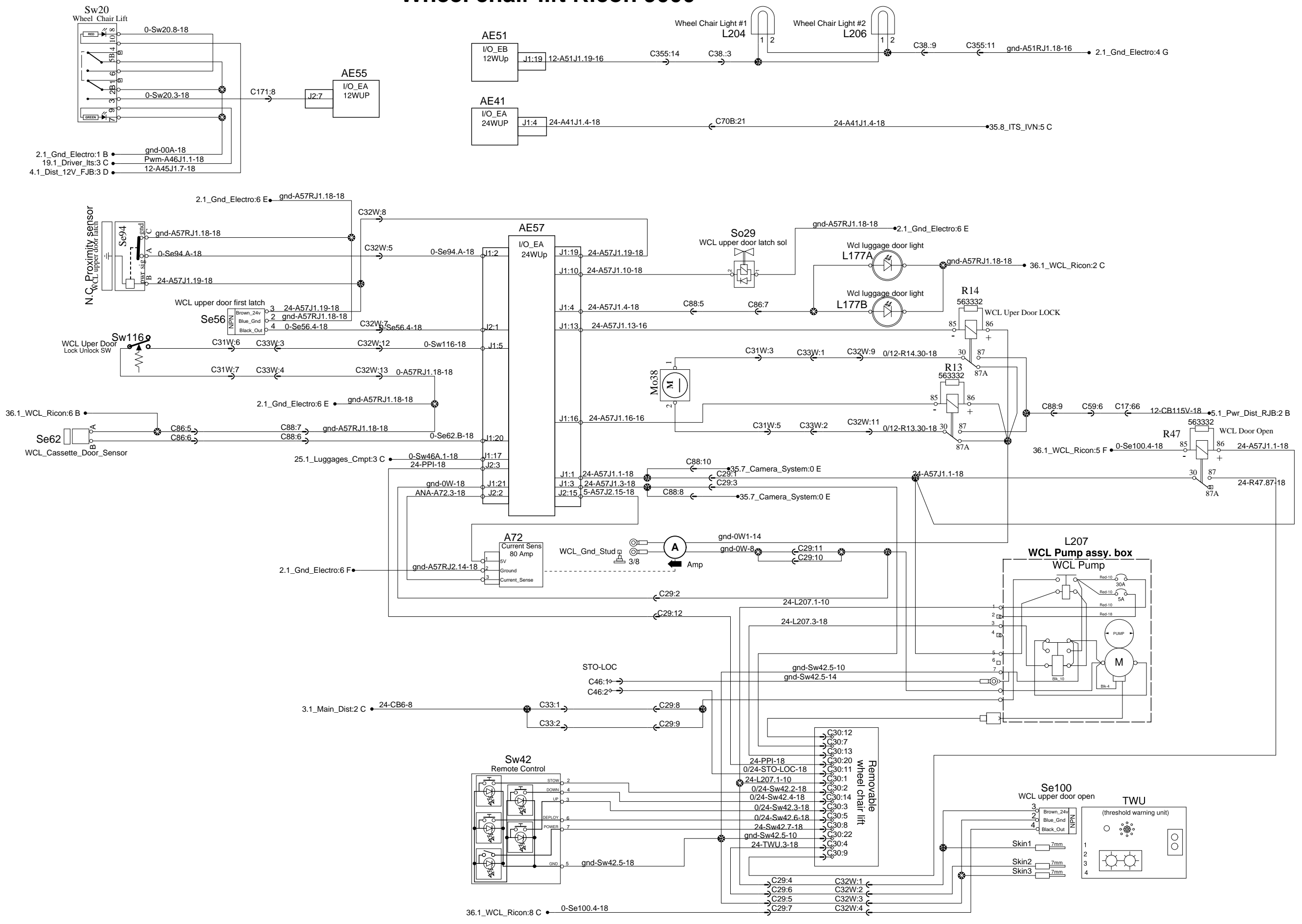

# Volvo link TGW

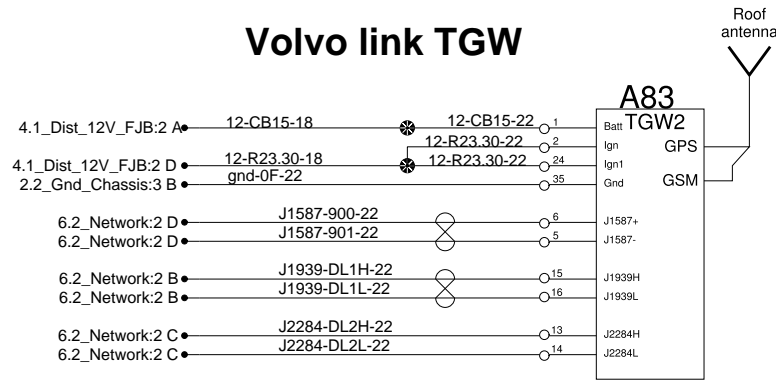

# Air dryer heater



# Oil separator - Wet tank

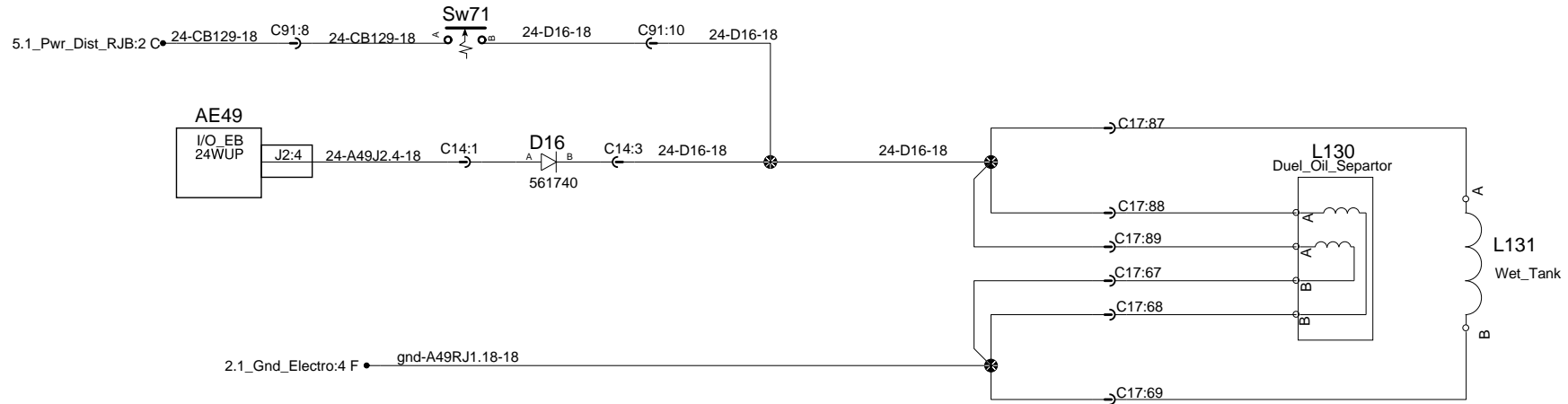

# Volvo link TGW

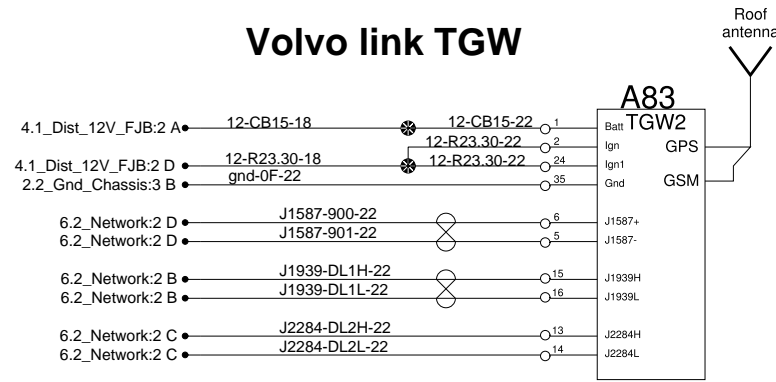

# Air dryer heater

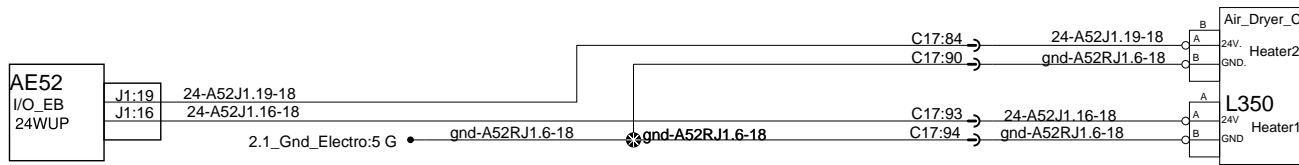

# Oil separator - Wet tank

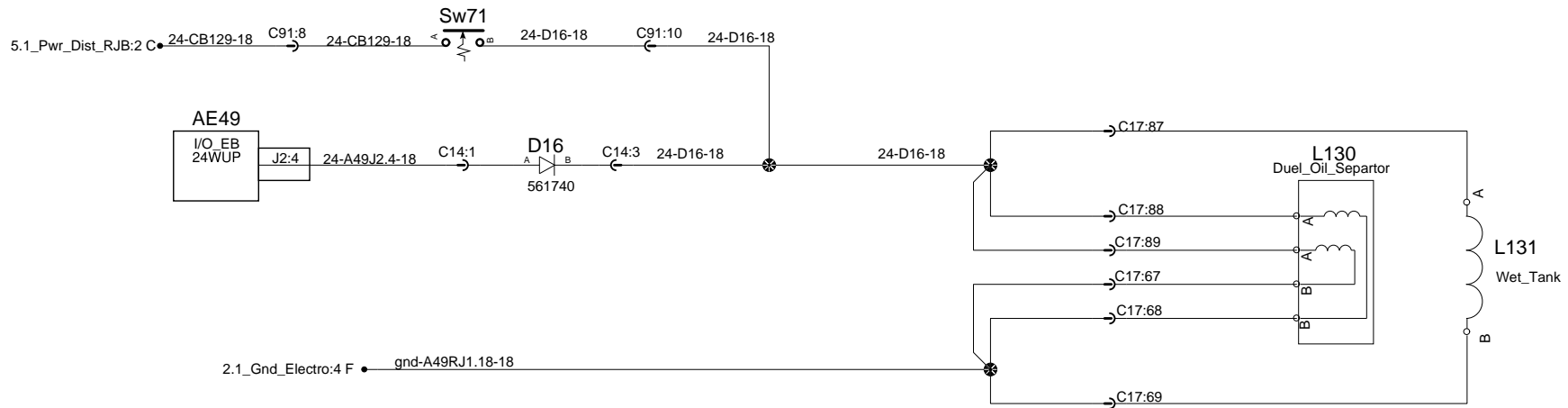

# Automatic fire suppression system (KIDDE)

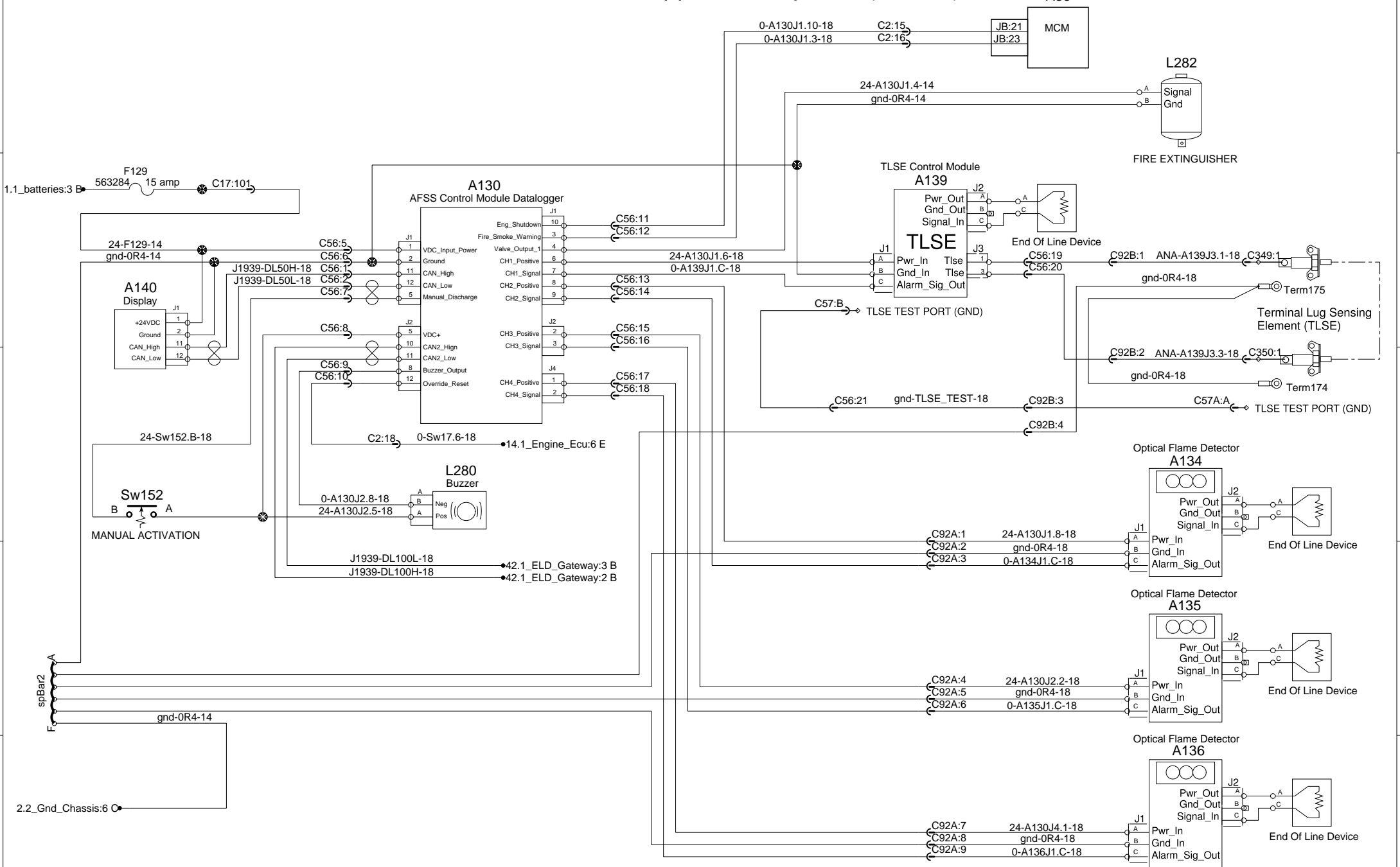



# Automatic fire suppression system (KIDDE)

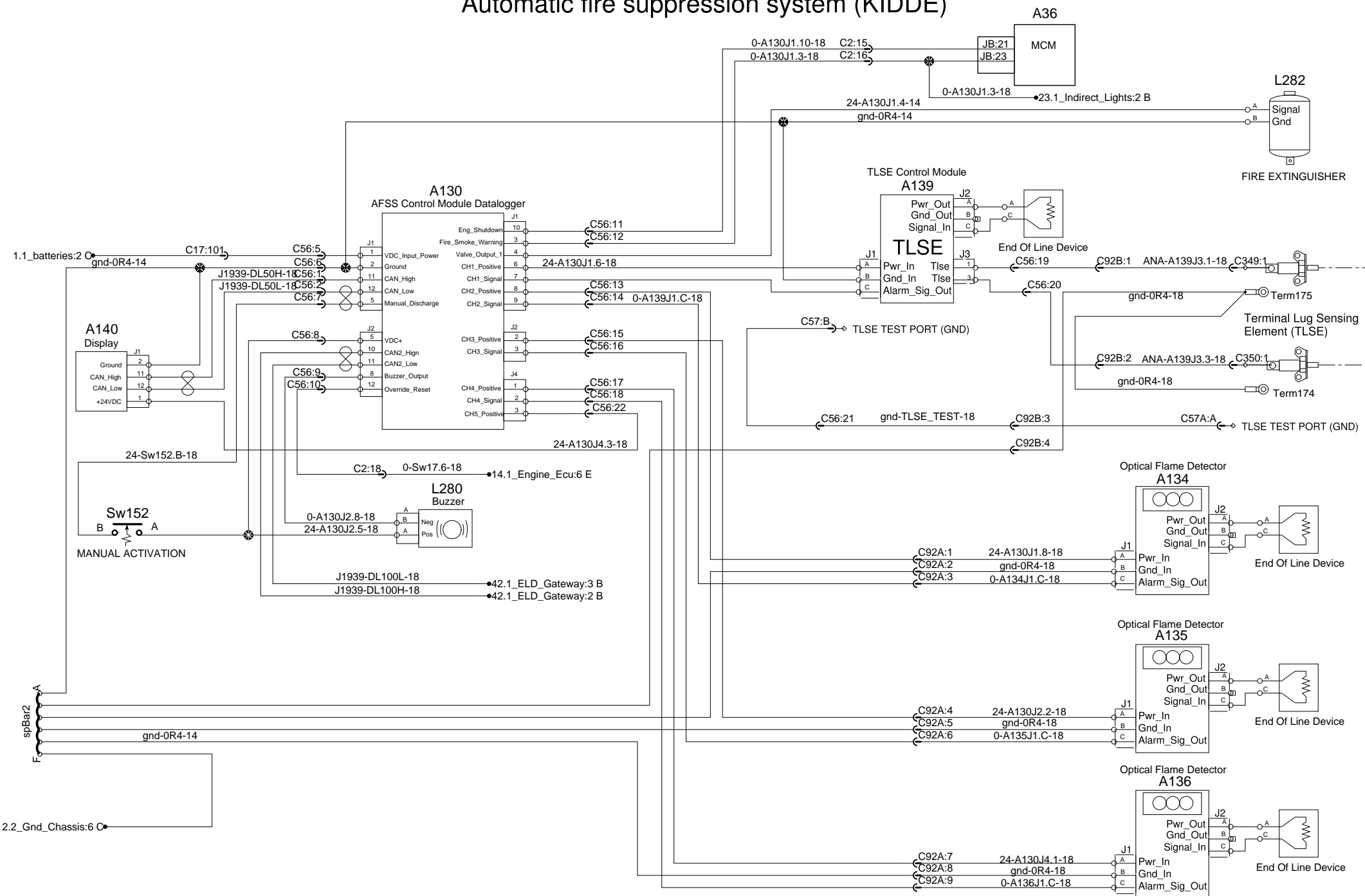

# Converter 24/12V

A

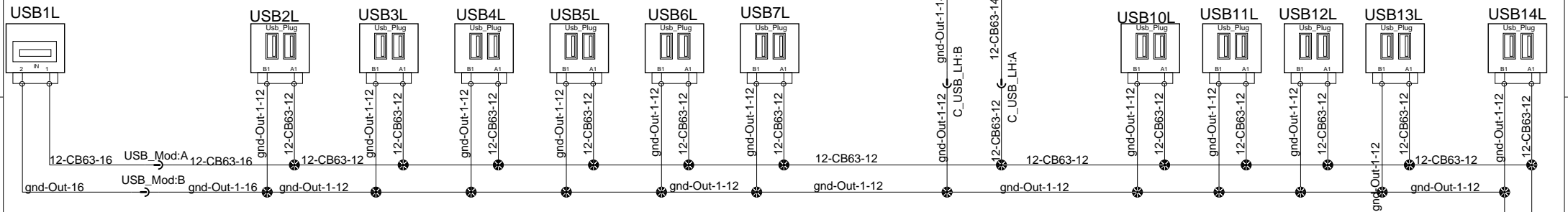

B

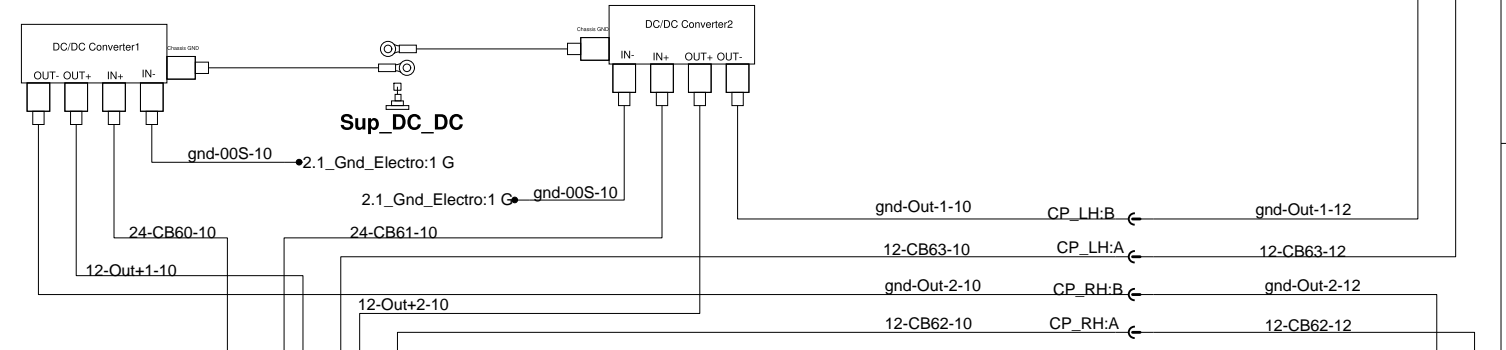

C

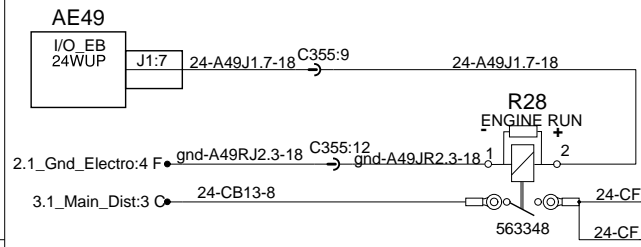

D

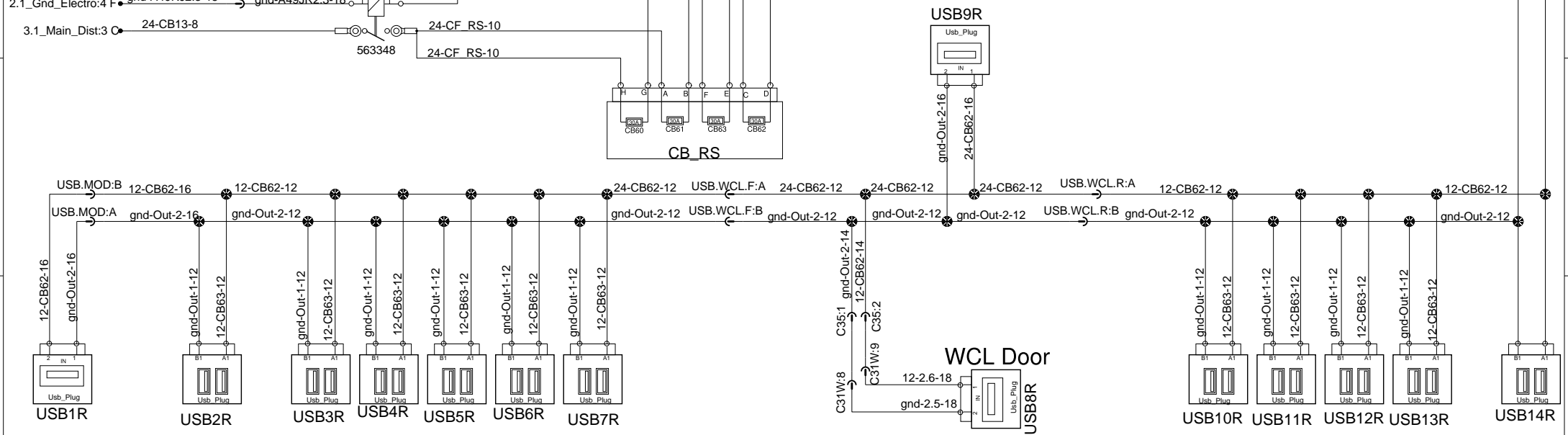

E

# Converter 24/12V

A

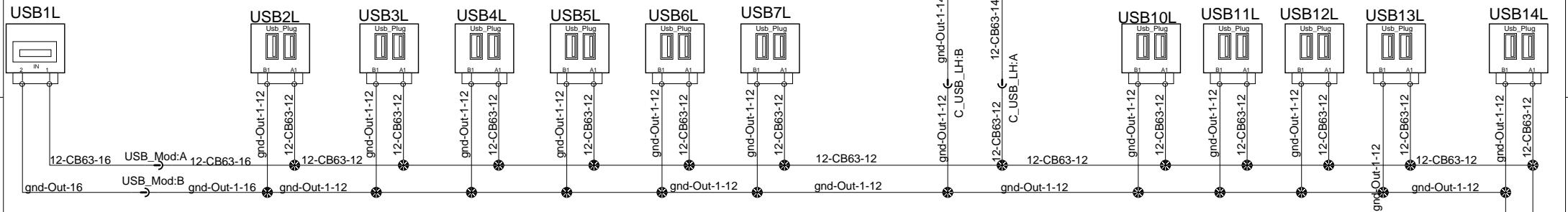

B

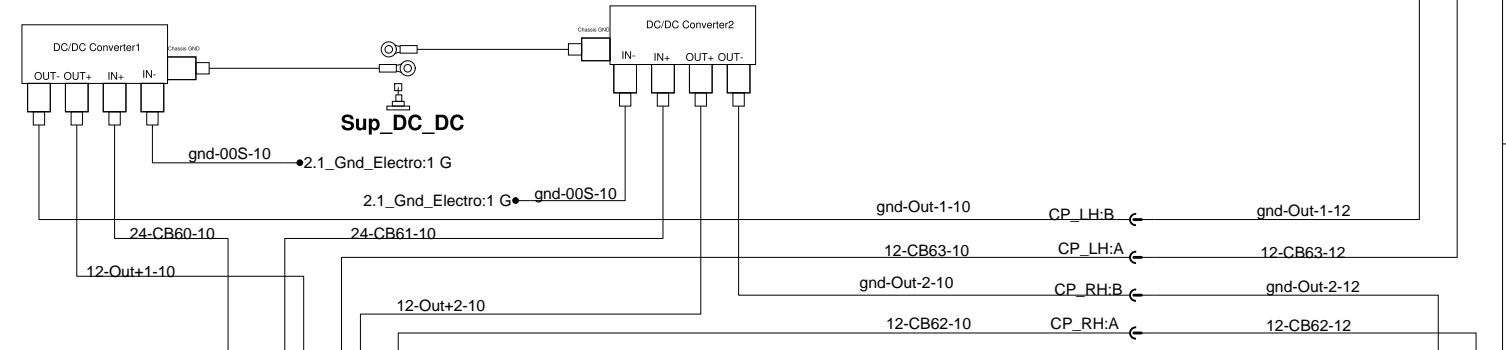

C

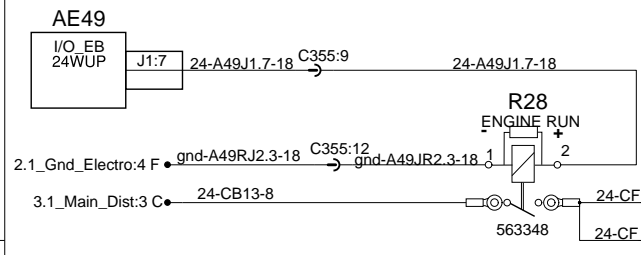

D

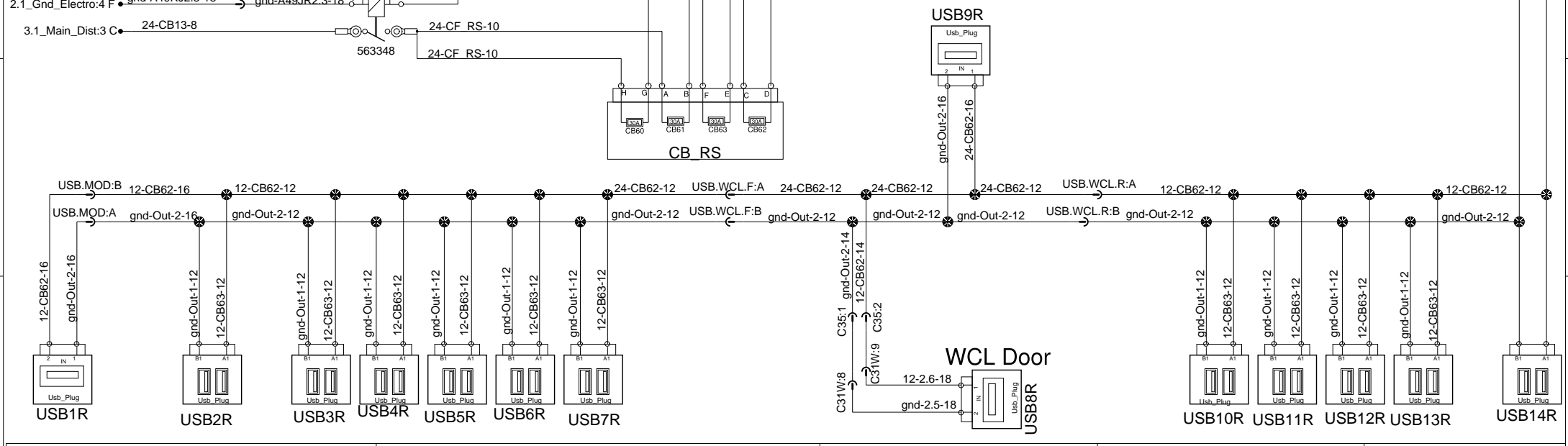

E

1

2

3

4

5

# Gateway

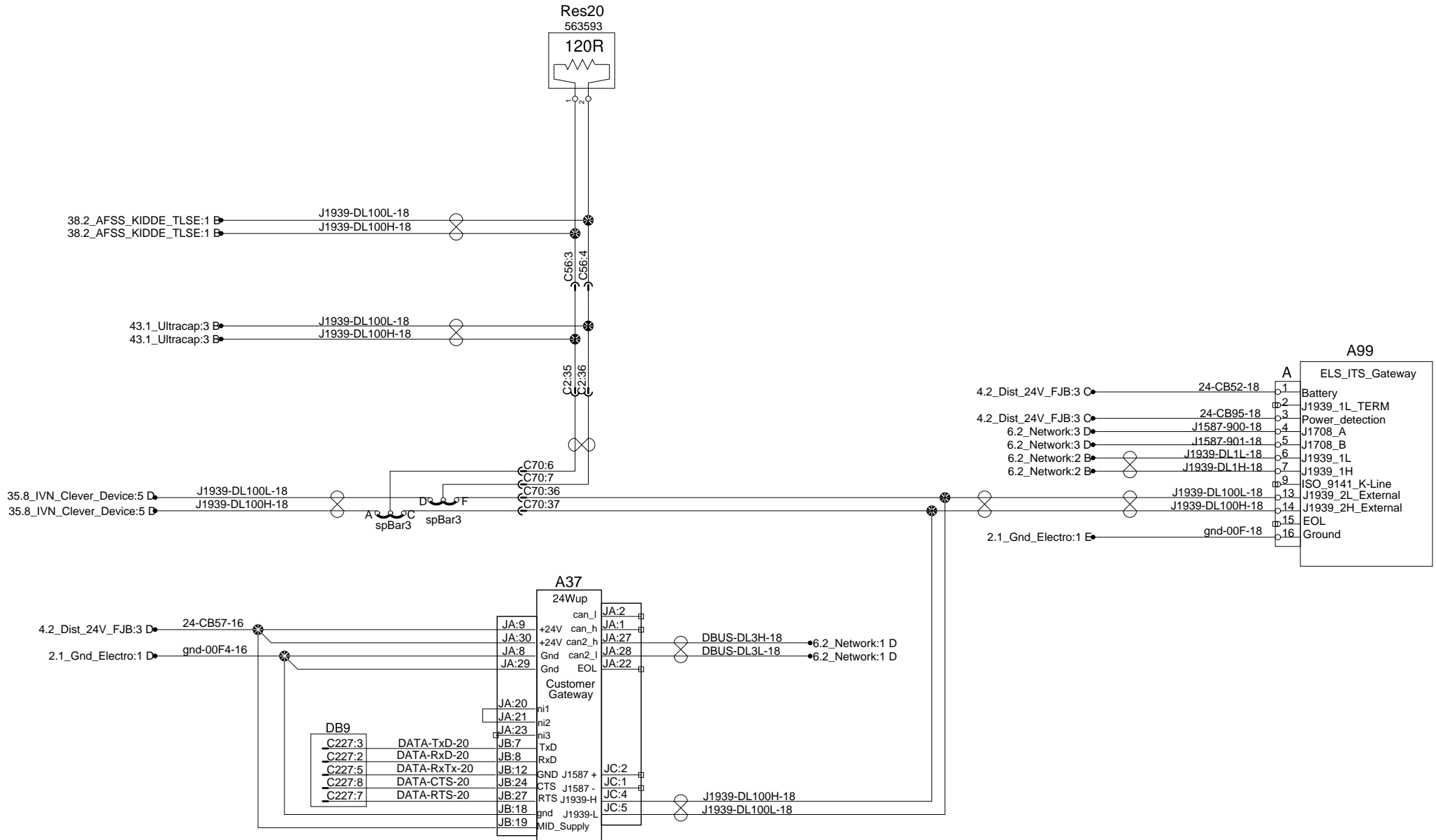

# Gateway

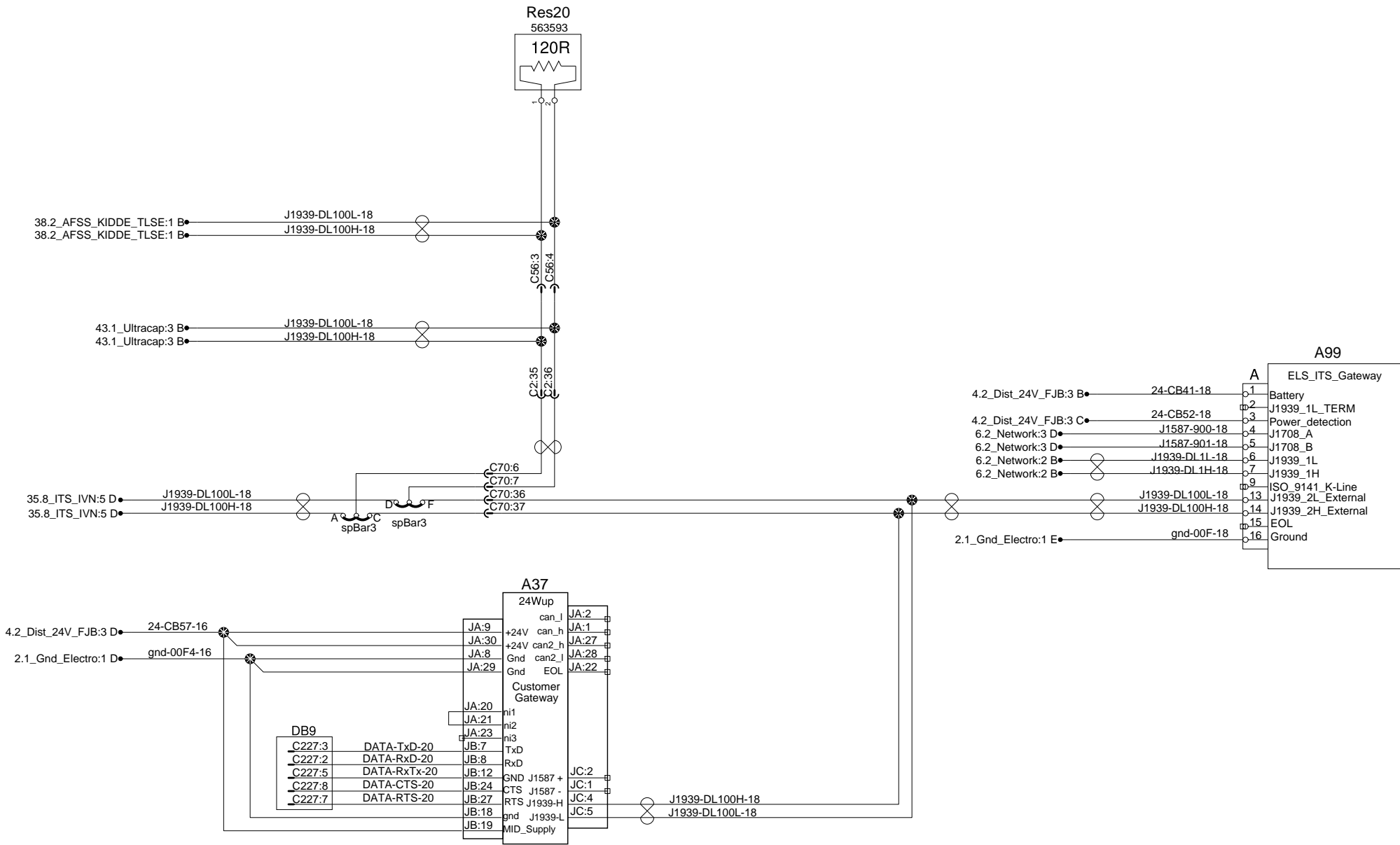

# Ultracap (Starting aid)

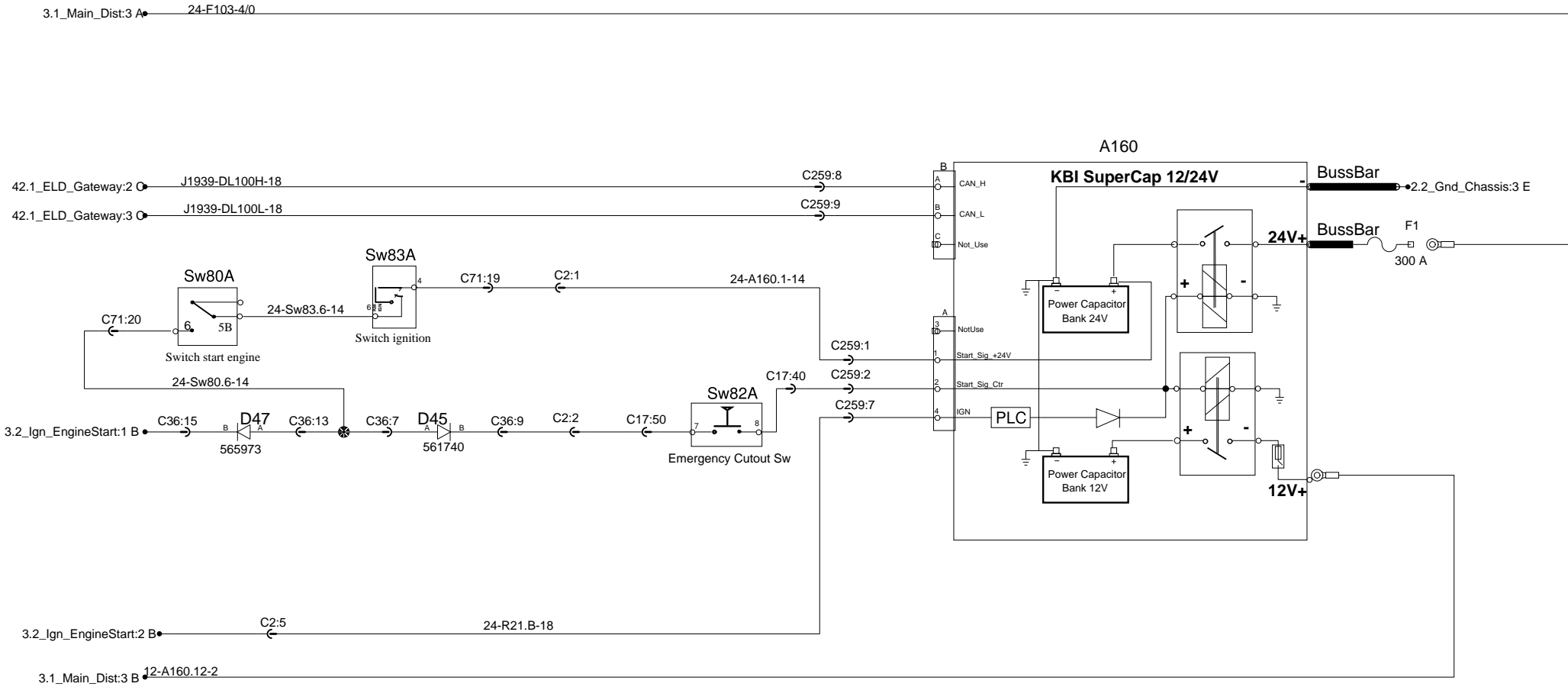

# Ultracap (Starting aid)

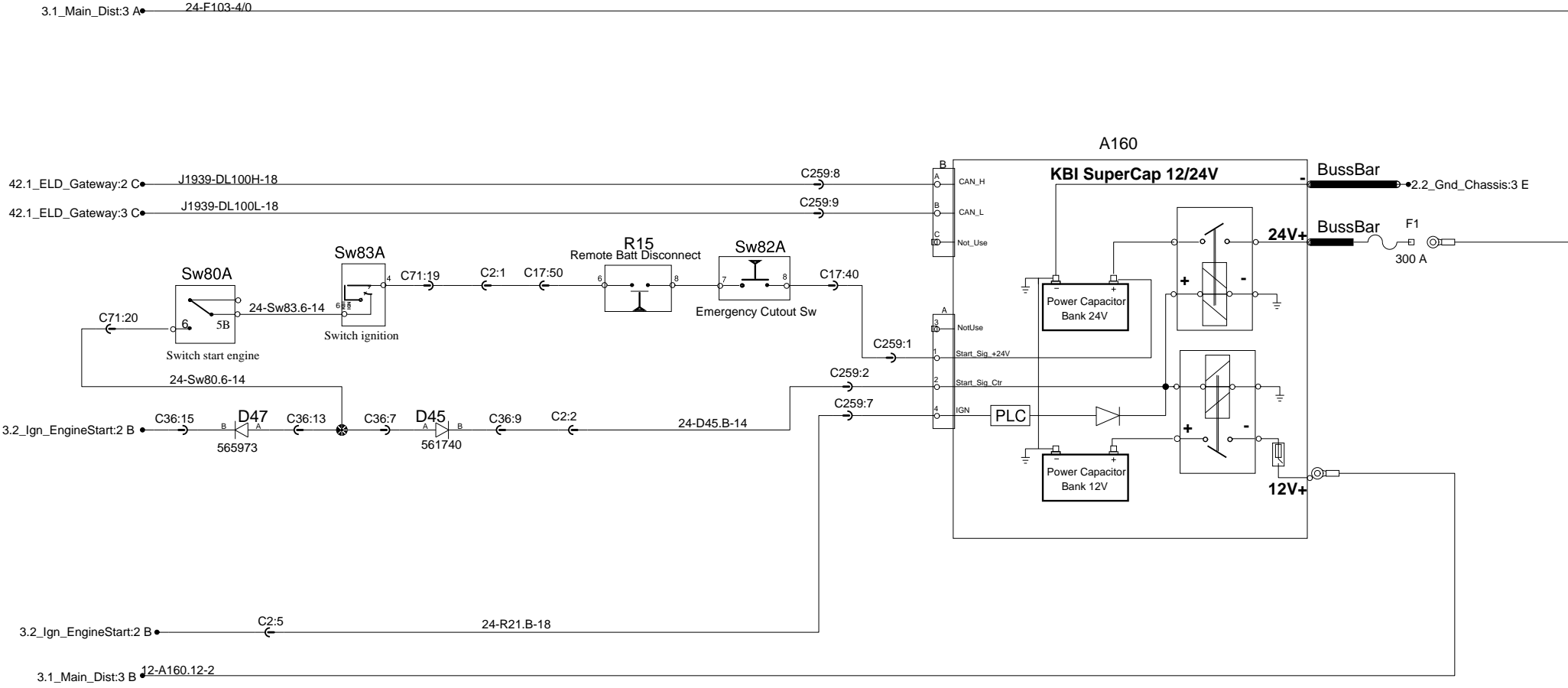

# Plasma Cluster Prevost Comm Series

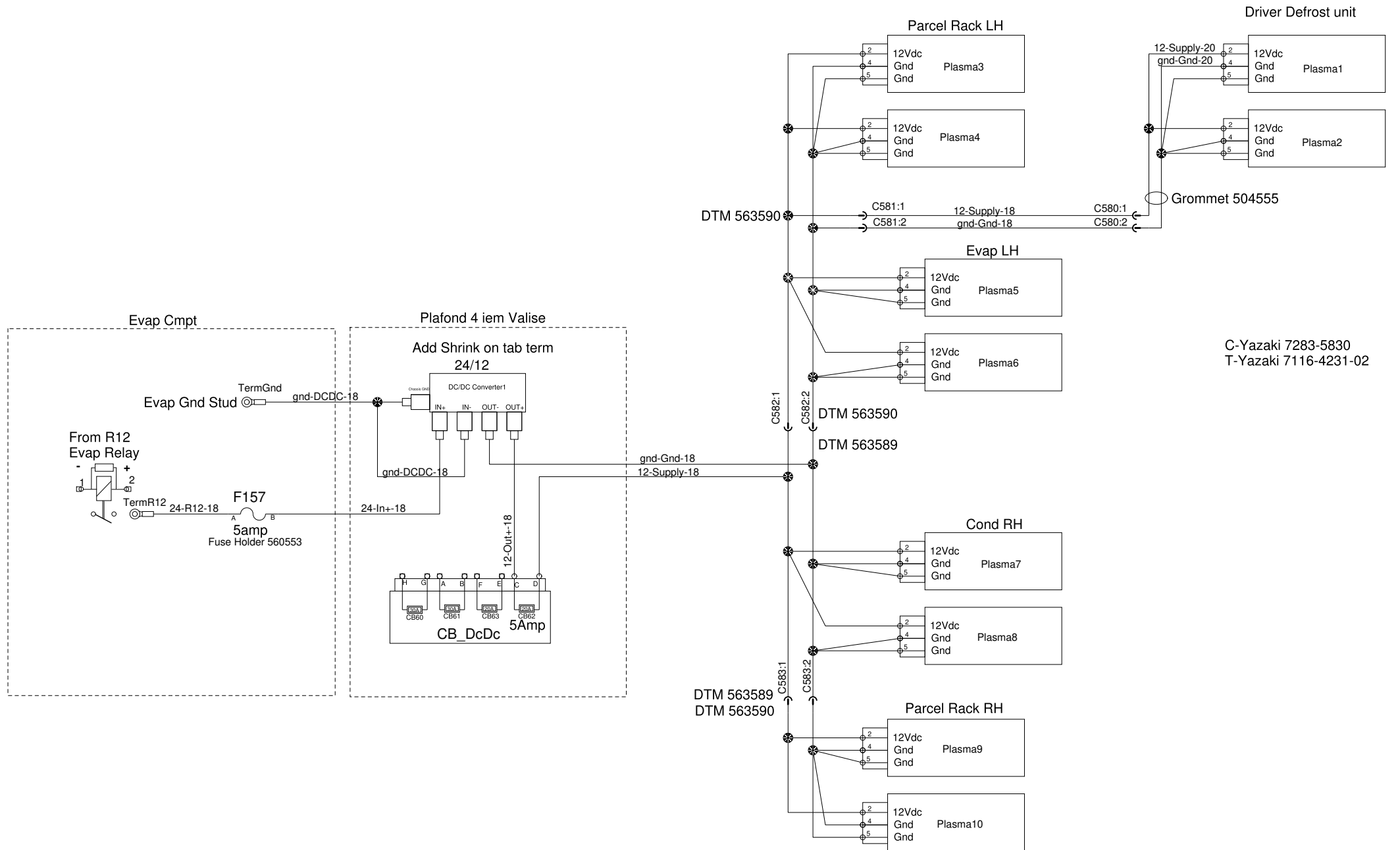

C-Yazaki 7283-5830  
T-Yazaki 7116-4231-02