

# SECTION 00 : GENERAL INFORMATION

## CONTENTS

1. FOREWORD .....	00-2
2. SCHEMATICS.....	00-2
3. PRECAUTIONS TO BE OBSERVED BEFORE WELDING.....	00-2
4. SAFETY NOTICE.....	00-3
4.1 DATA PLATES AND CERTIFICATIONS.....	00-3
4.1.1 Engine.....	00-3
4.1.2 Transmission.....	00-3
4.1.3 Drive Axle.....	00-4
4.1.4 Front Axle.....	00-4
4.1.5 Power Steering Pump.....	00-4
4.1.6 Coach Final Record.....	00-4
4.1.7 Safety Certification.....	00-4
4.1.8 DOT Certification Label .....	00-4
4.1.9 EPA Engine Label.....	00-4
4.1.10 Fuel Tank Label .....	00-5
4.1.11 Vehicle Identification Number (VIN).....	00-5
5. FASTENER STRENGTH IDENTIFICATION .....	00-7
5.1 SELF-LOCKING FASTENERS .....	00-8
5.2 RECOMMENDATIONS FOR REUSE .....	00-8
5.3 SIX LOBED SOCKET HEAD.....	00-8

## ILLUSTRATIONS

FIGURE 1: DETROIT DIESEL SERIES 60 .....	00-3
FIGURE 2: WORLD TRANSMISSION.....	00-3
FIGURE 3: EATON TRANSMISSION.....	00-3
FIGURE 4: TYPICAL SERIAL & MODEL NUMBERS .....	00-4
FIGURE 5: TYPICAL SERIAL & MODEL NUMBERS .....	00-4
FIGURE 6: ISS TYPICAL SERIAL & MODEL NUMBERS .....	00-4
FIGURE 7: POWER STEERING PUMP NAMEPLATE .....	00-4
FIGURE 8: ENGINE COMPARTMENT .....	00-5
FIGURE 9: VEHICLE I.D. 00-5	
FIGURE 10: VEHICLE IDENTIFICATION NUMBER 00-6	
FIGURE 11: THREAD NOTATION .....	00-7
FIGURE 12: BOLT STRENGTH MARKINGS .....	00-7
FIGURE 13: SELF-LOCKING FASTENERS .....	00-8
FIGURE 14: METRIC - US STANDARD CONVERSION TABLE .....	00-9
FIGURE 15: CONVERSION CHART .....	00-10

## Section 00 : GENERAL INFORMATION

---

### 1. FOREWORD

This manual includes procedures for diagnosis, service, maintenance and repair for components of the XL2 series coach or bus shell model listed on the front cover page.

This manual should be kept in a handy place for ready reference by the technician. If properly used, it will meet the needs of the technician and owner.

Information provided in Section 1 through 24 pertains to standard equipment items, systems and components as well as the most commonly used optional equipment and special equipment offered on the coach models covered by this manual.

At the beginning of each section: a Table of Contents and a list of illustrations give the page number on which each subject begins and where each figure is located.

Coach operating information is provided in a separate Operator's Manual. Audio/Video system operator instructions are also included in a separate manual.

More specific information on engine and transmission operating, maintenance, and overhaul information is contained in the applicable engine or transmission service manual published by the engine or transmission manufacturer. Engine and transmission parts information is contained in the applicable engine or transmission parts catalog published by the engine or transmission manufacturer.

All information, illustrations and specifications contained in this manual are based on the latest product information available at the time of publication approval. The right is reserved to make product changes at any time without notice.

*Note: Typical illustrations may be used, therefore minor illustration difference may exist when compared to actual parts or other publications.*

Prévost Car occasionally sends Maintenance Information, Warranty Bulletins, Campaign Bulletins or other literature to update users with the latest service procedures. They are issued, when required, to supplement or supersede information in this manual. Update sheet should be filled out and bulletins should be filed at the

end of their respective section for future reference.

### 2. SCHEMATICS

Vehicle AIR SCHEMATICS are provided at the end of Section 12, "Brake". SUSPENSION AIR SCHEMATICS are provided at the end of Section 16, "Suspension". Moreover, ELECTRICAL SCHEMATICS are provided in the technical publications box. Refer to those schematics for detailed circuit information or during diagnosis.

### 3. PRECAUTIONS TO BE OBSERVED BEFORE WELDING

**Caution:** Cut off battery power in main power compartment using battery safety switch.

1. Disconnect "Ground" cables from battery terminals.

**Note:** Disconnect "Ground" cables only.

2. If welding must be done near the dashboard i.e. steering column, you must disconnect all electronic control modules (radio & control head, HVAC, TTLT cluster Volvo). You must also disconnect alternator module located in front service compartment.

3. Disconnect three wiring harness connectors from ECM (Electronic Control Module). The ECM is mounted on the starter side of the engine.

4. For vehicles equipped with an Allison automatic transmission, disconnect three wiring harness connectors from ECU (Electronic Control Unit). The ECU is located in front service compartment.

5. For vehicles equipped with ABS (Anti-Lock Brake System), disconnect wiring harness connectors from ABS Electronic Control Unit. The ABS Electronic Control Unit is located in front service compartment.

6. Cover electronic control components and wiring to protect from hot sparks, etc.

7. Do not connect welding cables to electronic control components.

8. Do the appropriate welding on vehicle.

**Caution:** Position welding machine ground clamp as close as possible to the work.

9. When welding is complete, reconnect ECM, ECU, ABS electronic control units, etc.
10. Terminate by reconnecting "Ground" cables to battery terminals.

**4. SAFETY NOTICE**

This maintenance manual has been prepared in order to assist skilled mechanics in the efficient repair and maintenance of PRÉVOST vehicles.

This manual covers only the procedures as of manufacturing date.

Safety features may be impaired if other than genuine PRÉVOST parts are installed.

Torque wrench tightening specifications must be strictly observed. Locking devices must be installed or replaced by new ones, where specified. If the efficiency of a locking device is impaired, it must be replaced.

This manual emphasizes particular information outlined by the wording and symbols:

**Warning:** Identifies an instruction which, if not followed, could cause personal injuries.

**Caution:** Outlined an instruction which, if not followed, could severely damage vehicle components.

**Note:** Indicates supplementary information needed to fully complete an instruction. Although, the mere reading of such information does not eliminate the hazard, understanding of the information will promote its correct use.

**4.1 DATA PLATES AND CERTIFICATIONS**

Delay and confusion can be avoided by placing the complete vehicle identification number of the coach and the serial numbers of the engine on parts orders and correspondence. Also, the transmission, axles, power steering pump chassis and other major components are identified by serial numbers.

**4.1.1 Engine**

The engine serial and model number are stamped on the cylinder block (as viewed from the flywheel end) on the left side just below the fire deck and above the cast-in Detroit Diesel logo (Fig. 1).

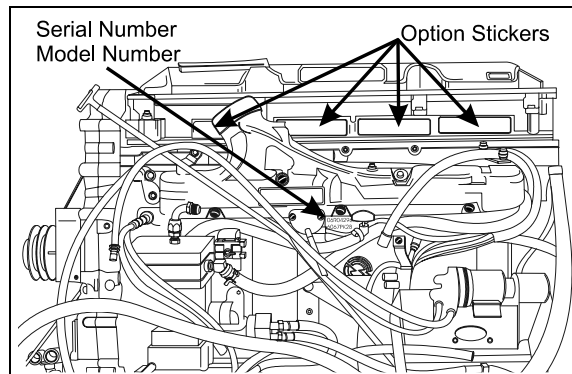

FIGURE 1 : DETROIT DIESEL SERIES 60 01054

In addition, option plates made of laminated paper are located on the rocker cover (starter side). The engine serial and model number and a list of the optional engine equipment is written on the option plate. Refer to this information when ordering replacement parts (Fig. 1).

**4.1.2 Transmission**

The transmission identification plate may be located on the right-rear side of the transmission. The identification plate shows the transmission serial number, part number (assembly number), and model number. Use all three numbers when ordering parts.

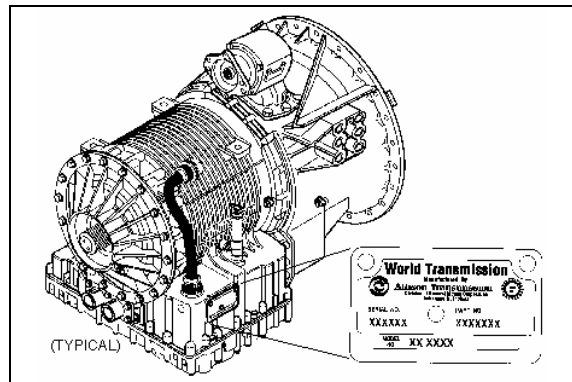

FIGURE 2: WORLD TRANSMISSION 07019

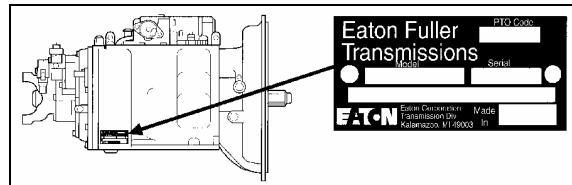

FIGURE 3: EATON TRANSMISSION 07062

## Section 00 : GENERAL INFORMATION

### 4.1.3 Drive Axle

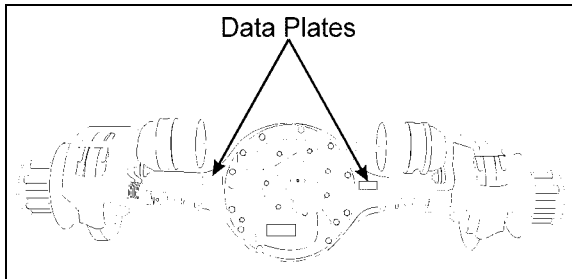

FIGURE 4: TYPICAL SERIAL & MODEL NUMBERS 11019

### 4.1.4 Front Axle

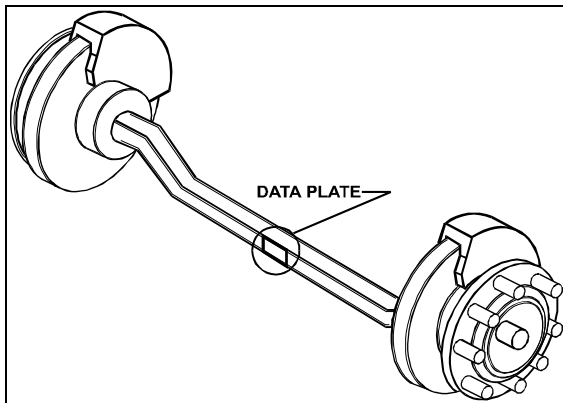

FIGURE 5: TYPICAL SERIAL & MODEL NUMBERS 10024

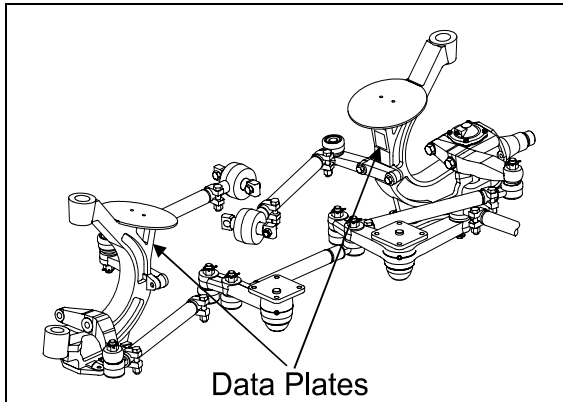

FIGURE 6: ISS TYPICAL SERIAL & MODEL NUMBERS

### 4.1.5 Power Steering Pump

Power steering pump serial number is located on a tag on the pump (Fig. 7). The pump is mounted on the engine beside the crankshaft pulley.

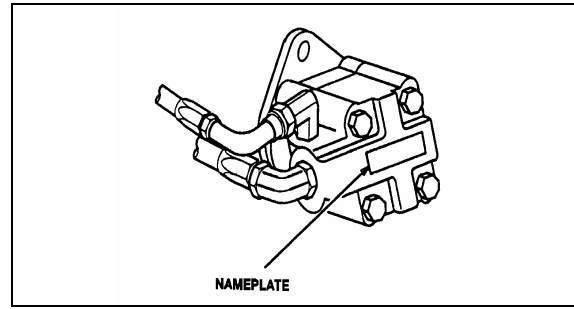

FIGURE 7 : POWER STEERING PUMP NAMEPLATE 00001

### 4.1.6 Coach Final Record

The Coach Final Record is a record of all data pertaining to the assembly of the coach. This record is included in the technical publication package supplied with the coach. Retain this record in the company records office for reference and safe-keeping.

### 4.1.7 Safety Certification

Coach components meet specifications and standards as follows:

- Material and parts conform to ASTM and/or SAE standards in effect at the time of manufacture.
- All factory-installed interior materials meet FMVSS 302 for fire resistance.
- Certified according to Provincial, State and Federal Safety standards (Canadian and US) BMCSS, FMVSS, and CMVSS.

Other applicable certification labels are affixed to the component.

### 4.1.8 DOT Certification Label

This certifies that coaches manufactured by Prevost Car Inc., comply with all Federal Motor Vehicle Safety Standards at the time of manufacture. The DOT Certification label is affixed on the wall, behind the driver's seat.

### 4.1.9 EPA Engine Label

The exhaust emission certification label affixed to the rear junction box certifies that the engine conforms to federal and any state exhaust emission regulations (Fig. 8). It gives the operating conditions under which certification was made.

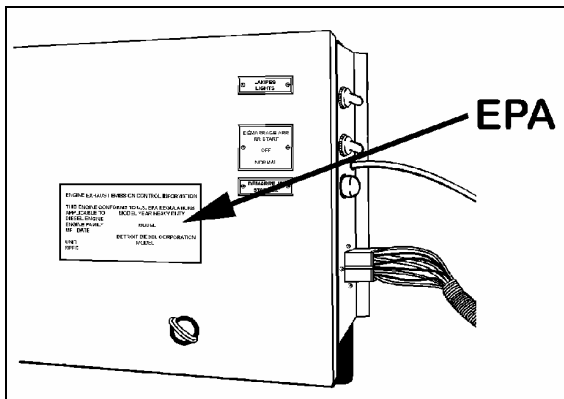

FIGURE 8 : ENGINE COMPARTMENT 01011

#### 4.1.10 Fuel Tank Label

The fuel tank label is molded on the side of the fuel tank. To read this label, unscrew the fuel tank access panel nuts located at the left in the condenser compartment.

#### 4.1.11 Vehicle Identification Number (VIN)

The seventeen digit vehicle identification number (VIN) is located on a plate (Fig. 9 & 10) located on the windshield frame pillar (driver's side). The VIN is visible from the outside of the coach. Make sure the correct vehicle identification number is given when ordering replacement parts. Using the VIN when ordering parts will facilitate processing.

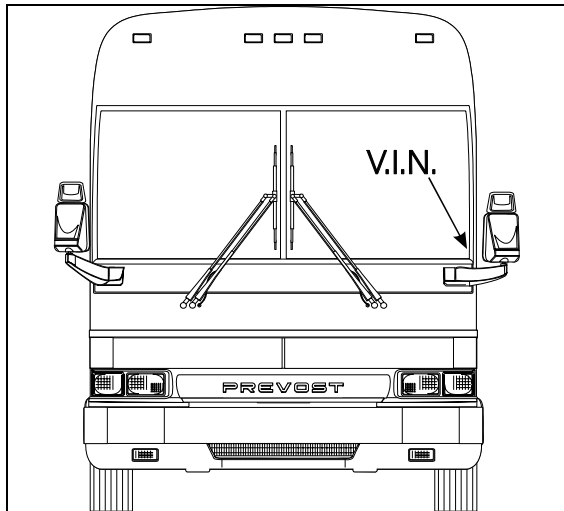
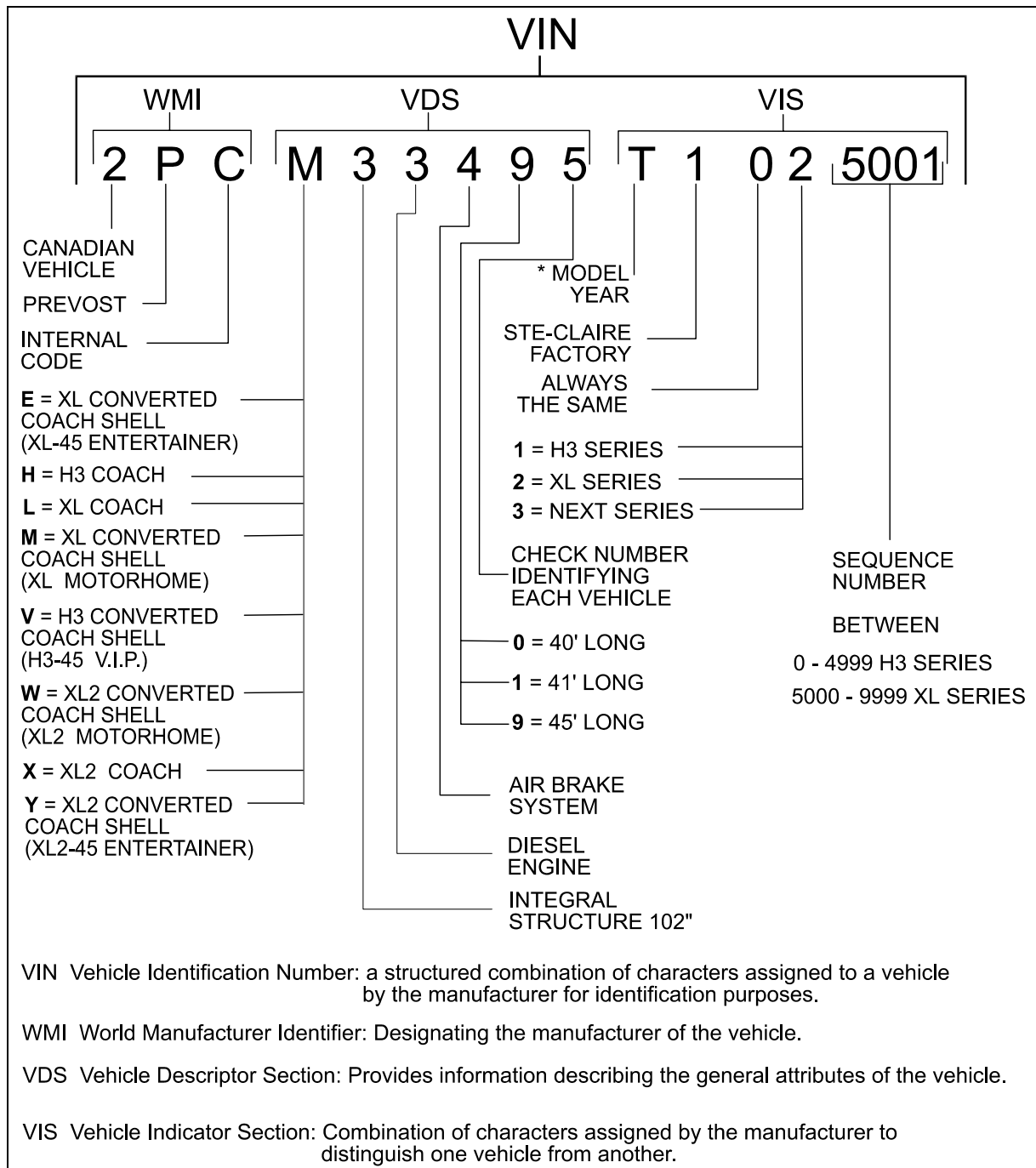

FIGURE 9 : VEHICLE I.D. 18309

**Note:** Record the VIN in the coach documentation and keep with company records. The VIN will normally be used for vehicle registration and for obtaining vehicle insurance coverage.

**Section 00 : GENERAL INFORMATION**



**FIGURE 10 : VEHICLE IDENTIFICATION NUMBER**

VIN1

YEAR	CODE	YEAR	CODE
1996	T	1999	X
1997	V	2000	Y
1998	W	2001	Z

**5. FASTENER STRENGTH IDENTIFICATION**

Most commonly used metric fastener strength property classes are 9.8 and 10.9 with the class identification embossed on the head of each bolt. Customary (inch) strength classes range from grade 2 to 8 with radial line identification embossed on each bolt head actual grade (i.e., a grade 7 bolt will have 5 embossed radial lines on the bolt head). Some metric nuts will be marked with single digit strength identification numbers on the nut face. Fig. 12 shows the different strength markings. When replacing metric

fasteners, be careful to use fasteners of the same or greater strength than the original fasteners (the same number marking or higher). It is also important to select replacement fasteners of the correct size. Correct replacement fasteners are available through the parts division. Some metric fasteners available in after-market parts sources were designed to metric standards of countries other the United States and may be of a lower strength, may not have the numbered head marking system, and may be of a different thread pitch.

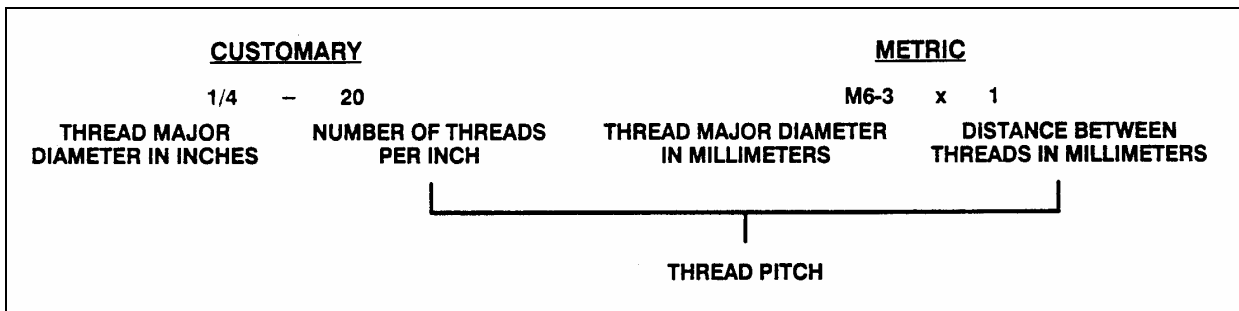

FIGURE 11 : THREAD NOTATION

00002

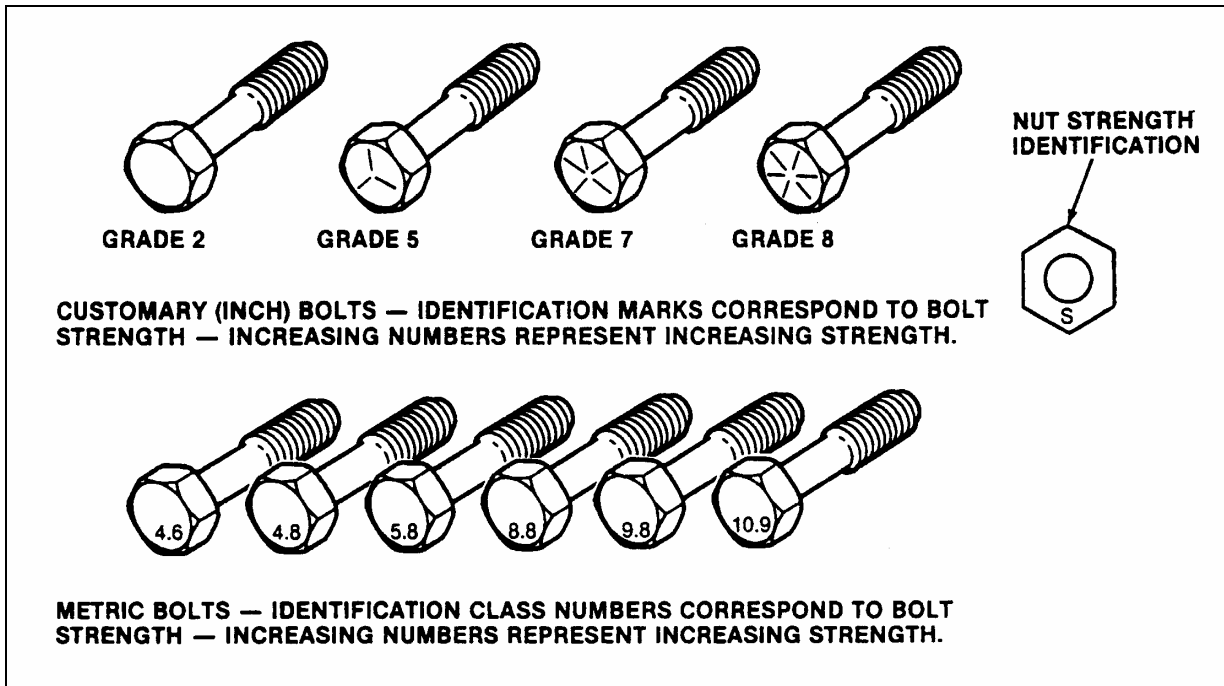

FIGURE 12: BOLT STRENGTH MARKINGS

00003

The metric fasteners used on the coach are designed to new standards and may not yet be manufactured by some non-domestic fastener suppliers. In general, except for special applications, the common sizes and pitches are :

- M 8 X 1.25;
- M 10 X 1.5;
- M 12 X 1.75;
- M 14 X 2;

**Section 00 : GENERAL INFORMATION**

**5.1 SELF-LOCKING FASTENERS**

A self-locking fastener is designed with an interference fit between the nut and bolt threads. This is most often accomplished by distortion of the top thread of an all-metal nut or bolt or by using a nylon patch on the threads. A nylon insert or the use of adhesives may also be used as a method of interference between nut and bolt threads (Fig. 13).

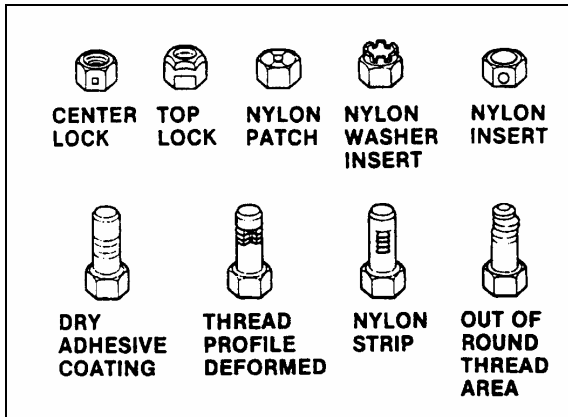

FIGURE 13 : SELF-LOCKING FASTENERS 00004

**5.2 RECOMMENDATIONS FOR REUSE**

Clean, unruined self-locking fasteners may be reused as follows :

- a) Clean dirt and other foreign matter from the fastener;
- b) Inspect the fastener to ensure there is no crack, elongation, or other sign of fatigue or overtightening. If there is any doubt, replace with a new self-locking fastener of equal or greater strength;
- c) Assemble parts and hand start fastener;
- d) Observe that, before the fastener seats, it develops torque per the chart in table two. If there is any doubt, replace with a new self-locking fastener of equal or greater strength;
- e) Tighten the fastener to the torque specified in the applicable section of this manual;

Fasteners which are rusty or damaged should be replaced with new ones of equal or greater strength.

SELF-LOCKING FASTENER TORQUE CHART									
METRIC		6 & 6.3	8	10	12	14	16	20	
NUTS AND ALL-METAL BOLTS	N•m	0.4	0.8	1.4	2.2	3.0	4.2	7.0	
	lbf•in	4.0	7.0	12	18	25	35	57	
ADHESIVE OR NYLON COATED BOLTS	N•m	0.4	0.6	1.2	1.6	2.4	3.4	5.6	
	lbf•in	4.0	5.0	10	14	20	28	46	
US STANDARD		.250	.312	.375	.437	.500	.562	.625	.750
NUTS AND ALL-METAL BOLTS	N•m	0.4	0.6	1.4	1.8	2.4	3.2	4.2	6.2
	lbf•in	4.0	5.0	12	15	20	27	35	51
ADHESIVE OR NYLON COATED BOLTS	N•m	0.4	0.6	1.0	1.4	1.8	2.6	3.4	5.2
	lbf•in	4.0	5.0	9.0	12	15	22	28	43

**5.3 SIX LOBED SOCKET HEAD**

Six lobed socket head (Torx) fasteners are used in some applications on vehicles covered in this manual. The tools designed for these fasteners are available commercially. However, in some cases, if the correct tool is not available, a hex socket head wrench may be used.



Multiply	by	to get equivalent number of:	Multiply	by	to get equivalent number of:
	<b>LENGTH</b>			<b>ACCELERATION</b>	
Inch	25.4	millimeters (mm)	Foot/sec <sup>2</sup>	0.305	meter/sec <sup>2</sup> (m/s <sup>2</sup> )
Foot	0.305	meters (m)	Inch/sec <sup>2</sup>	0.026	meter/sec <sup>2</sup>
Yard	0.914	meters			
Mile	1.609	kilometers (km)		<b>TORQUE</b>	
	<b>AREA</b>		Pound-inch	0.113	newton-meters (N·m)
Inch <sup>2</sup>	645.2	millimeters <sup>2</sup> (mm <sup>2</sup> )	Pound-foot	1.35	newton-meters
Foot <sup>2</sup>	6.45	centimeters <sup>2</sup> (cm <sup>2</sup> )			
Yard <sup>2</sup>	0.093	meters <sup>2</sup> (m <sup>2</sup> )		<b>POWER</b>	
	0.836	meters <sup>2</sup>	Horsepower	0.746	kilowatts (kW)
	<b>VOLUME</b>				
Inch <sup>3</sup>	16	mm <sup>3</sup>			
	387.0	cm <sup>3</sup>			
	16.387	liters (l)			
Quart	0.016	liters	Inches of water	0.249	kilopascals (kPa)
Gallon	0.946	liters	Pounds/sq. in.	6.895	kilopascals
Yard <sup>3</sup>	3.785	liters			
	0.765	meters <sup>3</sup> (m <sup>3</sup> )			
	<b>MASS</b>				
Pound	0.453	kilograms (kg)	BTU	1	055.0
Ton	907.18	kilograms (kg)	Foot-pound	1.356	joules (J)
Ton	0.907	ton (t)	kilowatt-hour	3	600 000.0
					joules (J = one W's)
					or 3.6 x 10 <sup>6</sup>
	<b>FORCE</b>				
Kilogram	9.807	newtons (N)			
Ounce	0.278	newtons			
Pound	4.448	newtons	Foot candle	1.076	lumens/meter <sup>2</sup> (lm/m <sup>2</sup> )
	<b>TEMPERATURE</b>				
Degree Fahrenheit	(°F - 32) ÷ 1.8	Degree Celsius (C)	Miles/hour	1.609	kilometers/hr (km/h)

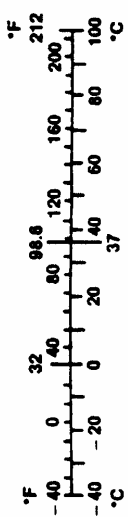

FIGURE 14: METRIC - US STANDARD CONVERSION TABLE

00005

<b>DECIMAL AND METRIC EQUIVALENTS</b>					
<b>FRACTIONS</b>	<b>DECIMAL IN.</b>	<b>METRIC MM</b>	<b>FRACTIONS</b>	<b>DECIMAL IN.</b>	<b>METRIC MM</b>
1/64	.015625	.39688	33/64	.515625	13.09687
1/32	.03125	.79375	17/32	.53125	13.49375
3/64	.046875	1.19062	35/64	.546875	13.89062
1/16	.0625	1.58750	9/16	.5625	14.28750
5/64	.078125	1.98437	37/64	.578125	14.68437
3/32	.09375	2.38125	19/32	.59375	15.08125
7/64	.109375	2.77812	39/64	.609375	15.47812
1/8	.125	3.1750	5/8	.625	15.87500
9/64	.140625	3.57187	41/64	.640625	16.27187
5/32	.15625	3.96875	21/32	.65625	16.66875
11/64	.171875	4.36562	43/64	.671875	17.06562
3/16	.1875	4.76250	11/16	.6875	17.46250
13/64	.203125	5.15937	45/64	.703125	17.85937
7/32	.21875	5.55625	23/32	.71875	18.25625
15/64	.234375	5.95312	47/64	.734375	18.65312
1/4	.250	6.35000	3/4	.750	19.05000
17/64	.265625	6.74687	49/64	.765625	19.44687
9/32	.28125	7.14375	25/32	.78125	19.84375
19/64	.296875	7.54062	51/64	.796875	20.24062
5/16	.3125	7.93750	13/16	.8125	20.63750
21/64	.328125	8.33437	53/64	.828125	21.03437
11/32	.34375	8.73125	27/32	.84375	21.43125
23/64	.359375	9.12812	55/64	.859375	21.82812
3/8	.375	9.52500	7/8	.875	22.22500
25/64	.390625	9.92187	57/64	.890625	22.62187
13/32	.40625	10.31875	29/32	.90625	23.01875
27/64	.421875	10.71562	59/64	.921875	23.41562
7/16	.4375	11.11250	15/16	.9375	23.81250
29/64	.453125	11.50937	61/64	.953125	24.20937
15/32	.46875	11.90625	31/32	.96875	24.60625
31/64	.484375	12.30312	63/64	.984375	25.00312
1/2	.500	12.70000	1	1.00	25.40000

FIGURE 15: CONVERSION CHART

00006