

SECTION 18: BODY

CONTENTS

1. VEHICLE EXTERIOR	18-6
2. STRUCTURE	18-9
2.1 WELDING.....	18-9
3. EXTERIOR MAINTENANCE	18-9
3.1 CORROSION PREVENTION	18-9
3.2 PREVENTIVE MAINTENANCE SCHEDULE	18-10
3.3 RUST INHIBITOR APPLICATION.....	18-10
4. FIBERGLASS REPAIR.....	18-15
4.1 REPAIR USING FIBERGLASS CLOTH.....	18-15
4.2 REPAIR USING FIBERGLASS PASTE	18-15
4.3 TYPICAL FIBERGLASS REPAIR PROCEDURE	18-16
5. PAINTING	18-17
5.1 NEW PAINT CARE	18-17
5.2 PAINT TOUCHUP	18-17
5.3 PAINTING	18-17
5.3.1 <i>Safety</i>	18-17
5.3.2 <i>Surface Preparation and Paint Application</i>	18-18
5.4 FRONT AND REAR BUMPERS	18-18
5.4.1 <i>Paint touchup and surface preparation for vehicles equipped with urethane bumpers</i>	18-18
6. FRONT AND REAR BUMPERS.....	18-19
6.1 FRONT BUMPER REMOVAL AND INSTALLATION.....	18-19
6.1.1 <i>Molded Front Bumper Removal</i>	18-19
6.1.2 <i>Front Bumper Assembly Removal including spare wheel compartment door</i>	18-19
6.2 FRONT BUMPER LICENSE PLATE SUPPORT INSTALLATION	18-19
6.3 REAR BUMPER REMOVAL AND INSTALLATION	18-20
7. COACH ENTRANCE DOOR	18-20
7.1 OPERATION	18-20
7.2 EMERGENCY EXIT VALVES.....	18-21
7.2.1 <i>Without Air and/or Without Electricity</i>	18-21
7.2.2 <i>With Air but Without Electricity</i>	18-21
7.3 DOOR CYCLE SPEED ADJUSTMENT	18-21
7.4 HORIZONTAL AND VERTICAL ADJUSTMENT	18-22
7.5 DEPTH ADJUSTMENT	18-23
7.6 ROD END ADJUSTMENT	18-23
7.7 LUBRICATION	18-23
7.8 TROUBLESHOOTING	18-24
8. ENTRANCE DOOR (V.I.P)	18-25
8.1 KEYLESS ENTRY SYSTEM	18-25
8.2 DOOR ADJUSTMENT	18-25
8.2.1 <i>Horizontal and Vertical Adjustments</i>	18-25
8.3 DEPTH ADJUSTMENT.....	18-25
8.4 DOOR LOWER SECTION.....	18-26
8.5 REFLECTOR STRIPE INSTALLATION.....	18-26
8.6 DOOR SEAL REPLACEMENT	18-26
8.7 DOOR LUBRICATION	18-27
8.8 DOOR LATCH MECHANISM.....	18-27

Section 18: BODY

9. DRIVER'S POWER WINDOW	18-27
9.1 WINDOW OR REGULATOR REMOVAL	18-27
9.2 WINDOW OR REGULATOR INSTALLATION	18-27
10. ROOF ESCAPE HATCH	18-28
10.1 REPAIR.....	18-28
10.2 SEALING	18-29
10.3 ESCAPE HATCH PANEL ASSEMBLY	18-29
10.4 ESCAPE HATCH FRAME	18-29
11. REPAIR OR REPLACEMENT OF "TARABUS" FLOOR COVERING	18-30
11.1 FRONT STEPS REPLACEMENT PROCEDURE	18-32
11.2 WELDING OF JOINT BETWEEN WHITE SAFETY STRIP AND "TARABUS" FLOOR COVERING	18-35
11.3 REPAIR OF A WELDED JOINT	18-38
12. PASSENGER SEATS	18-38
12.1 ROTATING SEATS.....	18-38
12.2 REMOVING FIXED SEATS	18-39
12.3 UPHOLSTERY MAINTENANCE	18-39
12.3.1 Routine Cleaning.....	18-39
12.3.2 Dry Cleaning	18-39
12.3.3 Cleaning With Covers in Place	18-39
13. COACH SIDE WINDOWS	18-40
13.1 EMERGENCY EXIT WINDOWS	18-40
13.2 EMERGENCY EXIT RELEASE BAR.....	18-41
13.2.1 Emergency Exit Window Adjustment.....	18-41
13.3 FIXED WINDOW REPLACEMENT	18-41
13.4 EMERGENCY EXIT WINDOW REPLACEMENT	18-42
13.5 TRAPEZOIDAL WINDOW REPLACEMENT	18-42
13.6 SMALL REAR WINDOWS REPLACEMENT	18-42
13.7 ADHESIVE-MOUNTED WINDOWS	18-42
13.7.1 Glass Window Replacement.....	18-42
14. WINDSHIELD	18-44
14.1 REMOVAL	18-44
14.2 WINDSHIELD INSTALLATION ONLY.....	18-45
14.3 INSTALLATION OF RUBBER EXTRUSION AND WINDSHIELD	18-46
15. BODY PANELS AND DOORS	18-46
16. BAGGAGE COMPARTMENT DOORS	18-47
16.1 PANTOGRAPH ADJUSTMENT	18-47
16.2 DOOR ADJUSTMENT	18-48
17. DOOR HANDLES	18-50
18. ENGINE COMPARTMENT DOOR	18-50
18.1 ENGINE DOOR ADJUSTMENT.....	18-50
18.2 MINOR TOP EDGE DEPTH ADJUSTMENT	18-51
18.3 MINOR LOWER EDGE DEPTH ADJUSTMENT:	18-51
19. ENGINE AIR INTAKE GRILL	18-51
20. RADIATOR DOOR ADJUSTMENT	18-51

21.	CONDENSER DOOR ADJUSTMENT	18-52
22.	FUEL FILLER DOOR	18-52
23.	FRONT SERVICE COMPARTMENT	18-53
23.1	LATCH MECHANISM ADJUSTMENT.....	18-54
24.	ENGINE COMPARTMENT R.H. SIDE DOOR	18-54
24.1	LATCH MECHANISM ADJUSTMENT.....	18-54
25.	EVAPORATOR DOOR ADJUSTMENT	18-54
25.1	LATCH MECHANISM ADJUSTMENT.....	18-55
26.	MAIN POWER COMPARTMENT	18-55
26.1	LATCH MECHANISM ADJUSTMENT.....	18-56
27.	FENDERS	18-56
27.1	REAR FENDER REMOVAL.....	18-56
27.2	FRONT FENDER REMOVAL	18-56
28.	REAR CAP	18-56
29.	FRONT CAP	18-57
30.	SIDE PANEL INSTALLATION PROCEDURE FOR COACHES AND VIP	18-57
31.	REAR VIEW MIRRORS (RAMCO)	18-62
31.1	ADJUSTMENT	18-62
31.2	DISASSEMBLY	18-62
31.3	ASSEMBLY.....	18-62
31.4	REPLACEMENT OF MIRROR GLASS.....	18-62
31.5	HEATED / REMOTE CONTROLLED REAR VIEW MIRRORS.....	18-62
31.5.1	<i>Mirror Control</i>	18-62
31.5.2	<i>Disassembly</i>	18-63
31.5.3	<i>Assembly</i>	18-63
31.5.4	<i>Convex & Flat Mirror Removal</i>	18-63
32.	VEHICLE JACKING POINTS	18-63
33.	TOWING THE VEHICLE	18-64
33.1	LIFTING AND TOWING	18-64
33.2	TOWING WITHOUT LIFTING	18-64
34.	SPECIFICATIONS	18-65

ILLUSTRATIONS

FIGURE 1: H3-45 EXTERIOR VIEW 18-6

FIGURE 2: H3-41 EXTERIOR VIEW 18-7

FIGURE 3: VIP CONVERTED VEHICLE EXTERIOR (TYPICAL)..... 18-8

FIGURE 4: FIBERGLASS REPAIR..... 18-16

FIGURE 5: FIBERGLASS REPAIR..... 18-16

FIGURE 6: FIBERGLASS REPAIR..... 18-16

FIGURE 7: FIBERGLASS REPAIR..... 18-16

FIGURE 8: FIBERGLASS REPAIR..... 18-17

FIGURE 9: BUMPER FASTENING MECHANISM 18-19

FIGURE 10: FRONT BUMPER ASSEMBLY 18-19

FIGURE 11: LICENSE PLATE SUPPORTS 18-20

FIGURE 12: REAR BUMPER ASSEMBLY 18-20

FIGURE 13: DOOR OPERATING SWITCH 18-21

FIGURE 14: EMERGENCY EXIT VALVE 18-21

FIGURE 15: DOOR CYLINDER AND DAMPER 18-21

FIGURE 16: COACH ENTRANCE DOOR..... 18-22

FIGURE 17: DAMPER 18-22

FIGURE 18: UPPER DOOR HINGE (COACH) 18-23

FIGURE 19: DOOR LATCH (COACH)..... 18-23

FIGURE 20: ENTRANCE DOOR (VIP) 18-25

FIGURE 21: ENTRANCE DOOR (VIP, TYPICAL) 18-27

FIGURE 22: DRIVER’S WINDOW 18-28

FIGURE 23: ESCAPE HATCH..... 18-29

FIGURE 24: ESCAPE HATCH..... 18-29

FIGURE 25: TARABUS FLOOR COVERING ADHESIVE APPLICATION 18-31

FIGURE 26: APPLICATION OF SIKA 221 GRAY 18-31

FIGURE 27: ARMREST 18-39

FIGURE 28: SEAT PEDESTAL ASSEMBLY..... 18-39

FIGURE 29: H3-45 COACH..... 18-40

FIGURE 30: H3-41 COACH..... 18-41

FIGURE 31: EMERGENCY EXIT WINDOW 18-41

FIGURE 32: FIXED WINDOW 18-41

FIGURE 33: EMERGENCY WINDOW 18-42

FIGURE 34: ADHESIVE-MOUNTED WINDOWS 18-42

FIGURE 35: ADHESIVE-MOUNTED WINDOW 18-43

FIGURE 36: ADHESIVE-MOUNTED WINDOW 18-43

FIGURE 37: ADHESIVE-MOUNTED WINDOW 18-43

FIGURE 38: WINDSHIELD 18-44

FIGURE 39: WINDSHIELD INSTALLATION TOP VIEW..... 18-44

FIGURE 40: WINDSHIELD INSTALLATION USING ROPE 18-45

FIGURE 41: WINDSHIELD INSTALLATION SIDE VIEW 18-45

FIGURE 42: APPLICATION OF SIKA 221 BLACK..... 18-45

FIGURE 43: BODY PANEL SPACING 18-46

FIGURE 44: BAGGAGE COMPARTMENT DOOR 18-47

FIGURE 45: PANTOGRAPH ADJUSTMENT 18-47

FIGURE 46: PANTOGRAPH DOOR ADJUSTMENT 18-48

FIGURE 47: PANTOGRAPH DOOR ADJUSTMENT 18-48

FIGURE 48: BAGGAGE COMPARTMENT DOOR 18-48

FIGURE 49: BAGGAGE COMPARTMENT DOOR 18-48

FIGURE 50: BAGGAGE COMPARTMENT DOOR 18-49

FIGURE 51: BAGGAGE COMPARTMENT DOOR 18-49

FIGURE 52: BAGGAGE COMPARTMENT DOOR 18-49

FIGURE 53: BAGGAGE COMPARTMENT DOOR	18-49
FIGURE 54: BAGGAGE COMPARTMENT DOOR	18-50
FIGURE 55: ENGINE COMPARTMENT DOOR	18-50
FIGURE 56: DOOR STOP	18-51
FIGURE 57: RADIATOR DOOR	18-51
FIGURE 58: CONDENSER DOOR	18-52
FIGURE 59: FUEL FILLER DOOR	18-52
FIGURE 60: DOOR HINGE	18-53
FIGURE 61: FRONT SERVICE DOOR	18-54
FIGURE 62: DOOR HINGE	18-54
FIGURE 63: ENGINE COMPARTMENT R.H. DOOR	18-54
FIGURE 64: EVAPORATOR DOOR	18-55
FIGURE 65: MAIN POWER COMP. DOOR	18-56
FIGURE 66: REAR-VIEW MIRROR (RAMCO)	18-62
FIGURE 67: JACKING POINTS ON STRUCTURE	18-63
FIGURE 68: JACKING POINTS ON FRONT AXLE	18-63
FIGURE 69: JACKING POINTS ON IND. SUSPENSION	18-63
FIGURE 70: JACKING POINTS ON DRIVE AXLE	18-63
FIGURE 71: JACKING POINTS ON TAG AXLE	18-64

Section 18: BODY

1. VEHICLE EXTERIOR

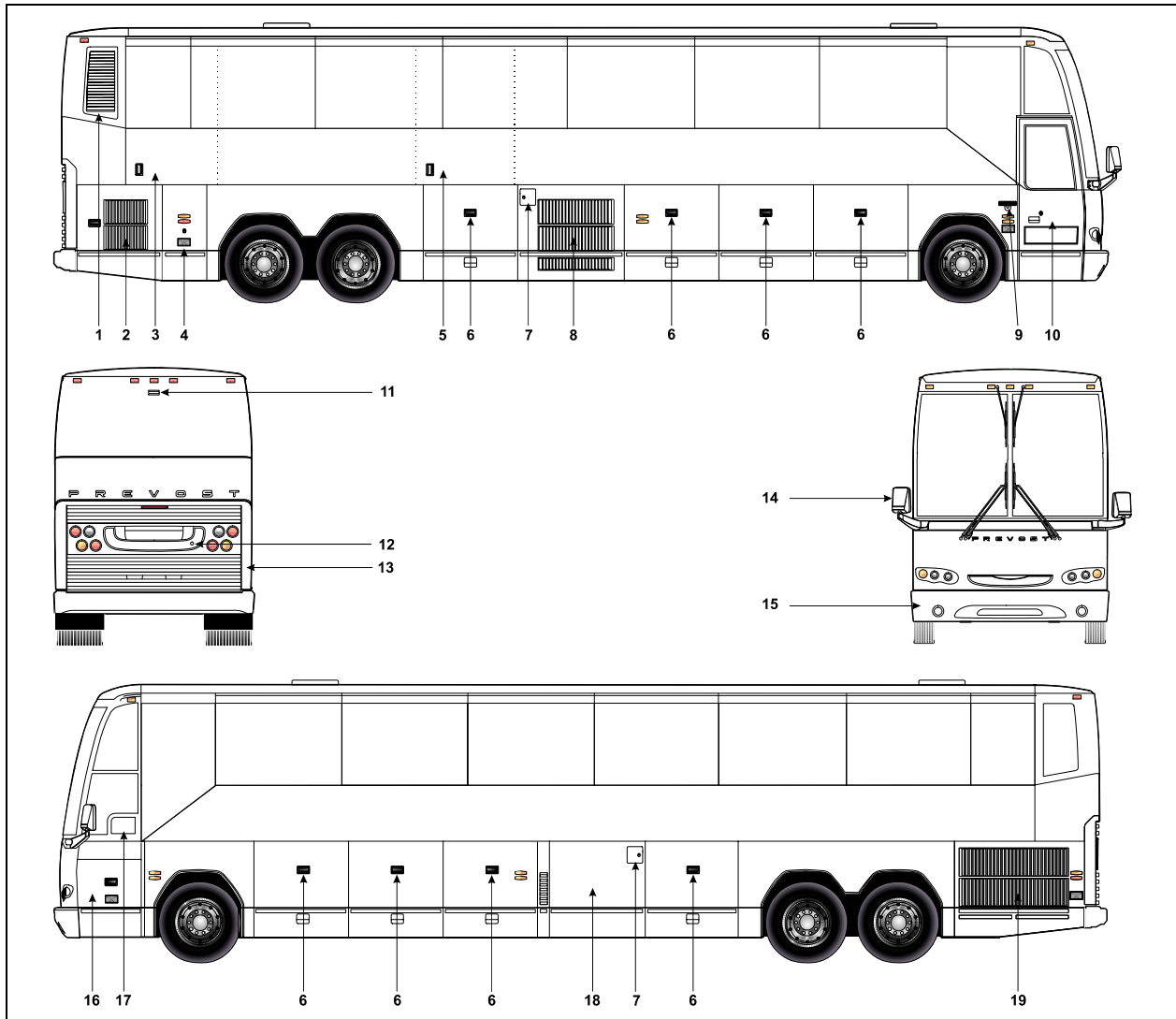

FIGURE 1: H3-45 EXTERIOR VIEW

18482

- | | |
|--|--|
| 1. Engine air intake | 11. Back-up camera (option) |
| 2. Engine compartment R.H. side door | 12. 110 - 120 volt connector |
| 3. Wheelchair lift door (option Stewart & Stevenson) | 13. Engine compartment rear door |
| 4. Main power compartment | 14. Rear-view mirrors |
| 5. Wheelchair lift door (option Ricon) | 15. Reclining bumper compartment |
| 6. Baggage compartment | 16. Front electrical & service compartment |
| 7. Fuel filler door | 17. Driver's power window |
| 8. A/C condenser door | 18. Heating, ventilating and air conditioning compartment (HVAC) |
| 9. Entrance door operating switch | 19. Engine radiator door |
| 10. Entrance door | |

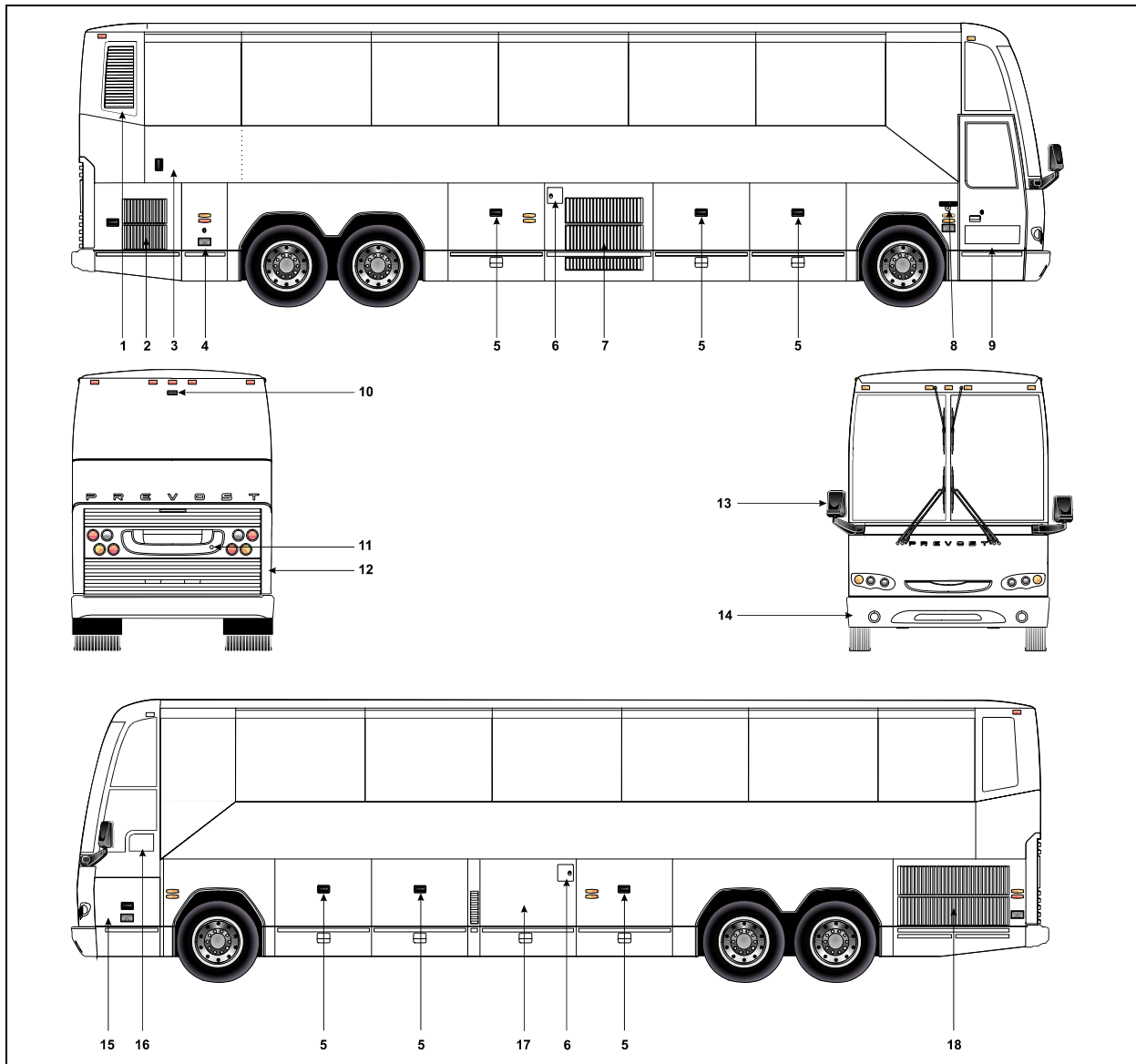

FIGURE 2: H3-41 EXTERIOR VIEW

18483

- | | |
|--|--|
| 1. Engine air intake | 11. 110 - 120 volt connector |
| 2. Engine compartment R.H. side door | 12. Engine compartment rear door |
| 3. Wheelchair lift door (option Stewart & Stevenson) | 13. Rear-view mirrors |
| 4. Main power compartment | 14. Reclining bumper compartment |
| 5. Baggage compartment | 15. Front electrical & service compartment |
| 6. Fuel filler door | 16. Driver's power window |
| 7. A/C condenser door | 17. Heating, ventilating and air conditioning compartment (HVAC) |
| 8. Entrance door operating switch | 18. Engine radiator door |
| 9. Entrance door | |
| 10. Back-up camera (option) | |

Section 18: BODY

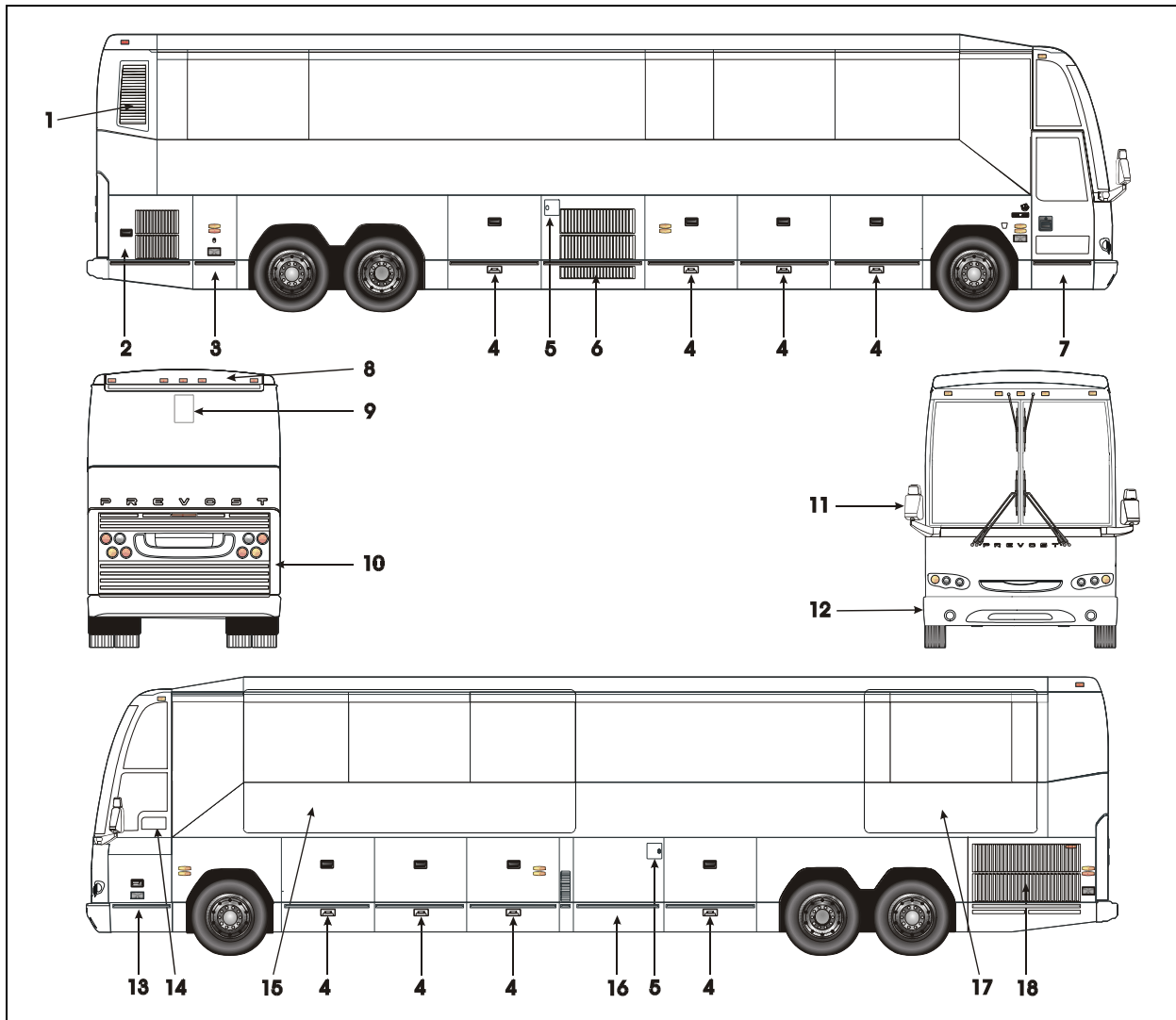

FIGURE 3: VIP CONVERTED VEHICLE EXTERIOR (TYPICAL)

18484

- | | |
|---|---|
| 1. Engine air intake | 10. Engine rear door |
| 2. Engine compartment R.H. side door | 11. Rear-view mirrors |
| 3. Main power compartment | 12. Reclining bumper compartment |
| 4. Baggage compartment | 13. Front electrical and service compartment |
| 5. Fuel filler door | 14. Driver's power window |
| 6. A/C condenser compartment or baggage compartment | 15. Front Slide-out (Optional) |
| 7. Entrance door | 16. Heating, ventilating and air conditioning compartment (HVAC) or baggage compartment |
| 8. Rear spoiler | 17. Rear Slide-out (Optional) |
| 9. Retractable back up camera (optional) | 18. Engine radiator door |

2. STRUCTURE

The body of the H3-41, H3-45 and VIP vehicles is an integral structure made of 14, 16 and 18 gauge welded and braced high tensile steel and stainless steel members. The roof arches are made with cold rolled, electrically welded (CREW) steel tubes, 1 ½" x 2" x 14 gauge. The inside is filled with urethane foam and the exterior is primed. The front subframe is made of open sections of high-strength steel alloy. These open sections permit a better application of primer and undercoating, and does not trap moisture. The rear subframe is made of closed sections of high tensile steel sealed at both ends.

2.1 WELDING

Since welding is a procedure that may be carried out either as specific instructions from Prévost or by an independent decision of the owner, the following information pertaining to welding should be read before beginning any welding procedure. The prohibitions and requirements outlined below must be followed during welding procedure:

1. Welding must be done only by a qualified and experienced person.
2. Adequate ground contacts and shields must be positioned as required to protect components from damage due to heat, contact by weld splatter, arcing, or other potentially damaging events associated with welding.
3. The following precautions are to be taken to protect the electronic control components. Refer to section 00, paragraph 3, "PRECAUTIONS TO BE OBSERVED BEFORE WELDING" in this manual.
4. Always wear the appropriate safety equipment.

Weld in clean and well ventilated area, and always have an appropriate fire extinguisher within your reach

3. EXTERIOR MAINTENANCE

Regular washing to remove dust and dirt is recommended. See "Operator's Manual" for more details on washing and cleaning your vehicle.

3.1 CORROSION PREVENTION

Preventive maintenance is a key factor in avoiding corrosion and must be considered as part of the regular service intervals. The entire underbody of the vehicle is sprayed with a heavy application of asphalt base undercoating.

The operating environment the vehicle is subjected to will largely influence the amount of dirt and corrosion that will accumulate over a given period. Corrosion is one of the most costly factors of part failure and shortened part life. It is, however, an item that can be controlled when it is conscientiously looked after and the proper steps are taken in a timely manner.

Certain areas of the coach are more vulnerable to corrosion than others, and it is these areas that should be addressed. For example, the rear baggage compartment bulkhead in the rear wheelhousing area contains many key components and should be examined regularly for corrosion. Other areas include the front wheelhousing area and the engine compartment.

Road splash will affect understructure, condenser coil and engine compartment. These areas must be thoroughly cleaned to remove dirt accumulations from flanges, channels and ledges. These places accumulate dirt and salt and hold it in direct contact with steel and aluminum surfaces. Use an understructure high pressure spray as part of a regular wash. Damaged undercoating or paint should be promptly repaired before corrosion can start.

Frequency of wash periods depends on operating conditions. During periods of exposure to salt, daily washing as described above is recommended. If underbody parts show evidence of rust or corrosion, treat as follows:

1. Remove dirt, grease and oil by solvent washing.
2. Remove corrosion as well as all loose coating by cleaning with a wire brush or sandblasting.

Caution: Sandblasting can be used for cleaning bulkheads, brackets and other structural members. It should not be used for exterior side paneling. Extreme care should be taken not to sandblast excessively.

3. Apply correct primer, paint and undercoating after removing all corrosion to prevent further damage.

Section 18: BODY

3.2 PREVENTIVE MAINTENANCE SCHEDULE

Note: TECTYL 185 GW rust inhibitor may have been applied on your vehicle underbody as an option, if this is the case follow this procedure thoroughly. For future application of product, refer to paragraph 3.3 in this section.

DESCRIPTION	INTERVALS		MAINTENANCE	CORRECTIVE ACTION	REFERENCE
	MONTHS	KM MILES			
BODY, EXTERNAL WINDOW FRAME	6	40 000 25 000	VISUALLY INSPECT SEALING BEADS CONDITION	REPAIR OR REPLACE SEALING BEADS IF NECESSARY	
VEHICLE UNDERBODY	12	100 000 60 000	USE A LOW PRESSURE SPRAY TO CLEAN UNDERSTRUCTURE AND VISUALLY INSPECT FOR CALCIUM DEPOSIT, CORROSION OR ANY DIRT ACCUMULATED ONTO EXPOSED SURFACES. VISUALLY INSPECT SEALING BEADS CONDITION. VISUALLY INSPECT IF UNDERFLOOR IS PEELING. VISUALLY INSPECT WHEELHOUSING COATING. MAKE SURE DISCHARGE TUBES ARE FREE FROM OBSTRUCTIONS	APPLY UNDERCOATING LOCALLY AS NECESSARY. APPLY UNDERCOATING LOCALLY AS NECESSARY REMOVE ANY OBSTRUCTION OR REPLACE DEFECTIVE TUBE	
SUSPENSION AND UNDERSTRUCTURE	12	100 000 60 000	VERIFY THE CONDITION OF ALL SUSPENSION AND UNDERSTRUCTURE FASTENERS AND CLAMPS	TIGHTEN OR REPLACE DEFECTIVE OR MISSING FASTENERS	
FLOOR COVERING	3	20 000 12 500	VISUALLY INSPECT IF FLOOR COVERING IS SHOWING SIGNS OF DETERIORATION SUCH AS CUTS, BURNS, ETC. ALSO, VISUALLY INSPECT SEALANT ALONGSIDE TRACKS. INSPECT WALL PANELS FROM BOTTOM TO WINDOWS	REPAIR OR REPLACE DEFECTIVE COVERING. MAKE SURE PROPER SEALANT IS USED.	
FLOOR CLEANING			CLEAN FLOOR COVERING AS NECESSARY		



WARNING: Failure to follow this preventive maintenance schedule will result in warranty void.

3.3 RUST INHIBITOR APPLICATION

Material: Tectyl 185 GW
R1KG21

Safety Rules: Use safety glasses
Supplied air hood
Solvent-resistant rubber gloves

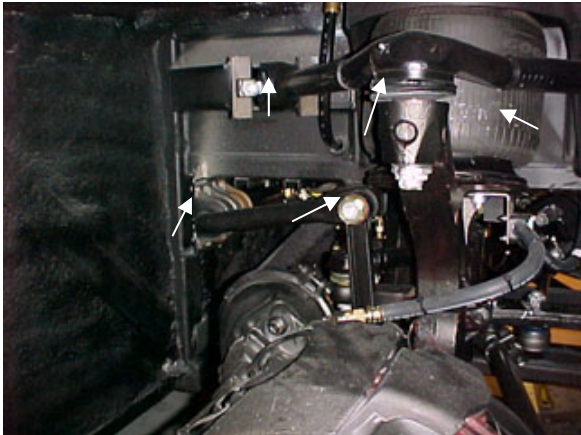
1.0 Wash both wheelhousing mechanical parts before masking.	A water-hose nozzle is recommended. Water may be hot to reduce washing time especially during winter. If parts are soiled with oil, clean using R1KG21. Avoid rubber
---	--

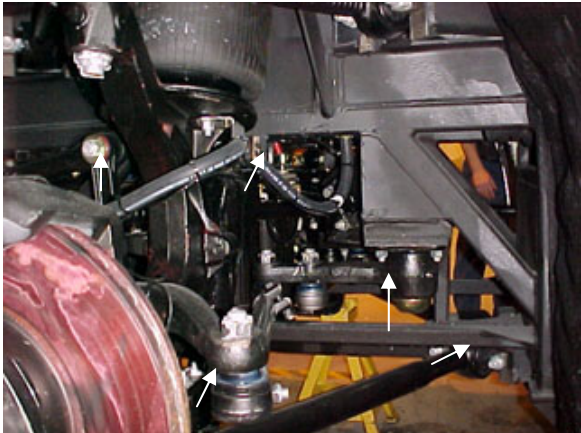
<p>2.0 Dry all water sprayed parts. Surface temperature and dew point must be respected before applying rust inhibitor.</p>	<p>parts. Air pressure system may be used, refer to annex 1 for surface temperature and dew point.</p>
<p>3.0 Front wheelhousing a) Mask all rubber joints. Braking system must also be protected (refer to arrows). Commercial aluminum foil may be used for masking.</p>	
<p>3.1 Front wheelhousing Front view</p>	
<p>3.2 Front wheelhousing</p>	

Section 18: BODY

3.3 Front wheelhousing

(Entire braking system)

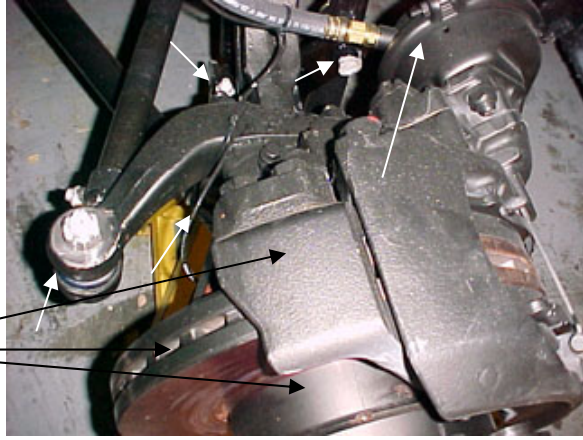

4.0 Rear wheelhousing

a) Mask all rubber joints. Braking system must also be protected (refer to arrows). Commercial aluminum foil may be used for masking

(Entire braking system)

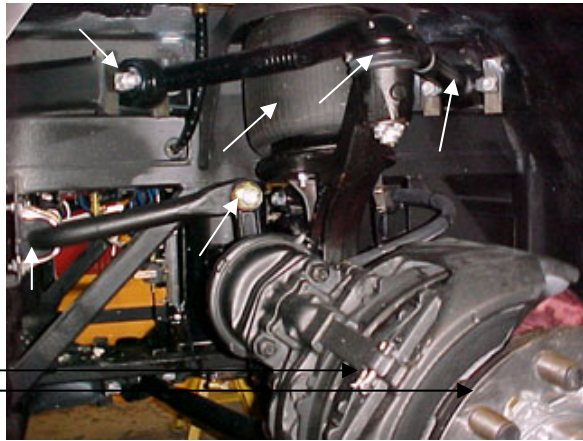

4.1 Rear wheelhousing

(Entire braking system)

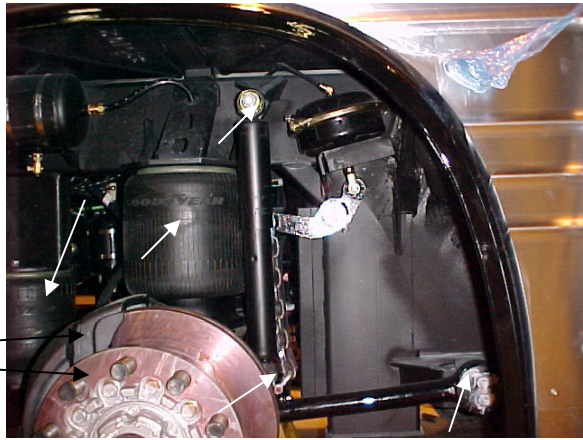

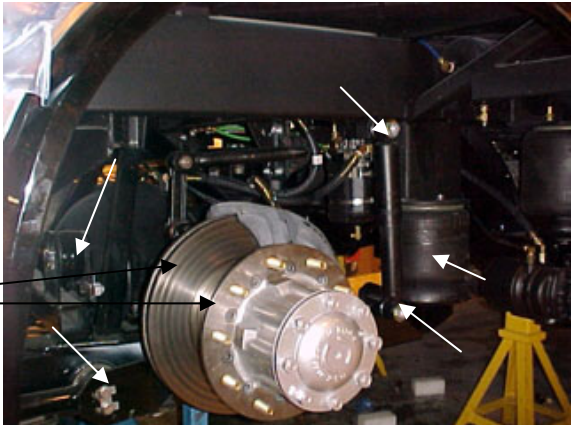
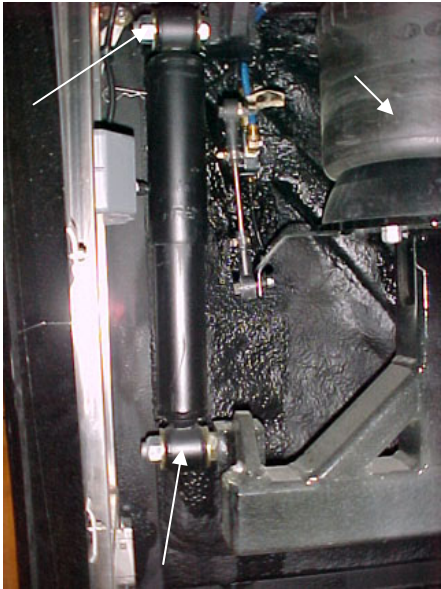
<p>4.2 Rear wheelhousing</p> <p>(Entire braking system)</p>	
<p>4.3 Rear wheelhousing</p>	
<p>5.0 Close off wheelhousing using masking paper.</p>	<p>Prevent rust inhibitor from coming in contact with paint. To close off wheelhousing, a polythene sheet may be used.</p>
<p>6.0 Apply TECTYL 185 GW black rust inhibitor onto wheelhousing mechanical parts.</p>	<p>A spray gun and pumping system are required to apply the rust inhibitor. If the application is done inside a paint room, select high speed ventilation. Minimum required thickness is 10 mils wet or 5 mils dry.</p>
<p>7.0 Remove all masking material 30 minutes after application.</p>	

ANNEX 1

1. Check and confirm that dew point and surface temperature are in accordance with to the following criteria:

Surface temperature > 10°C

Surface temperature > or = to dew point + 3°C

Note: Use the following table to determine dew point.

2. Check and confirm that TECTYL temperature is between 10°C and 35°C.

DEW POINT

	Relative Humidity (%)										
	10	20	30	40	50	60	70	80	90	100	
Temp (c)											
0	---	-16	-11	-8	-5	-3	-1	0	1	3	
1	---	-15	-10	-7	-5	-3	-1	1	2	4	
2	---	-14	-10	-6	-4	-1	0	2	3	5	
3	---	-13	-9	-5	-3	-1	1	2	4	6	
4	---	-13	-8	-5	-2	0	2	4	5	7	
5	---	-11	-7	-4	-1	1	3	5	6	8	
6	---	-11	-8	-3	0	2	4	6	7	9	
7	-18	-10	-6	-2	0	2	5	6	8	10	
8	-17	-9	-5	-1	1	4	6	7	9	11	
9	-16	-9	-4	-1	2	4	6	9	10	12	
10	-16	-8	-3	0	3	5	7	10	11	13	
11	-15	-7	-3	1	4	6	9	10	12	14	
12	-14	-6	-1	2	5	7	10	11	13	15	
13	-14	-6	-1	2	6	8	10	12	14	16	
14	-13	-5	0	4	6	9	11	14	15	17	
15	-12	-4	1	4	7	10	12	14	16	18	
16	-11	-4	1	5	9	11	13	15	17	19	
17	-10	-3	2	6	9	12	14	16	18	20	
18	-10	-2	3	7	10	13	15	17	19	21	
19	-9	-1	4	8	11	14	16	18	20	22	
20	-9	0		5	9	12	15	17	19	21	23
21	-8	0		5	10	13	16	18	20	22	24
22	-7	1		6	11	14	16	19	21	23	25
23	-6	2		7	11	15	17	20	22	24	26
24	-6	2		8	12	16	19	21	23	25	27
25	-5	3		9	13	16	20	22	24	26	28
26	-4	4		10	14	17	20	23	25	27	29
27	-4	5		11	15	19	21	24	26	28	30
28	-3	6		11	16	19	22	25	27	29	31
29	-2	6		12	17	20	23	26	28	30	32
30	-1	7		13	17	21	24	27	29	31	33
31	-1	8		14	19	22	25	27	30	32	34
32	0	9		15	20	23	26	29	31	33	35

4. FIBERGLASS REPAIR

All repairs to fiberglass parts consist of filling the damaged area with fiberglass cloth and resin or strand fiberglass and resin. The repair is allowed to harden, then finishing operations may be performed. Use of the various materials is determined by the type of repair to be made. Large holes, torn sections and separate joints require the adhesive qualities of the resin and the reinforcing qualities of the fiberglass.

Small dents, scratches or pits can be repaired using resin and strand fiberglass and filler mixed into paste. Instructions for either mix are explained under their respective headings in this section. For best results when making repairs, temperature should be between 70 and 75 °F (21-24 °C). Some people experience a skin reaction to resins. In such cases, wipe resin off with denatured alcohol or a good thinner. Use of protective hand cream is recommended.

Warning: Always wear a respirator and goggles when grinding or sanding.

Extreme care must be taken if the sander is electrically operated, as dust from some resins is combustible when subjected to sparks or open flames. The proper tool for sanding resin is a low speed, air driven disc sander with a water attachment or a dry sander having a vacuum bag. Either will eliminate flying glass and resin dust.

The following additional tools and materials will assist in making repairs: hacksaw blade, assorted files, emery paper or cloth (150 or finer), scissors or tin snips, wax paper or cellophane sheets, a 3" (75 mm) paint roller, paint brush, putty knife, acetone and one or more heat lamps.

4.1 REPAIR USING FIBERGLASS CLOTH

Where necessary, sand paint away around damaged area and scrape away undercoating, if any, and wipe clean with solvent. Grind or file the damaged area to form a "V" at the broken or cracked portion. Sides of "V" should have a shallow pitch for maximum bonding area.

Note: Roughening the surface improves adhesion of resin.

If part is warped from original shape, use clamping equipment to straighten the surface. Preheat area to be repaired with one or two heat lamps placed 18 to 24 inches (450-610 mm) from repair.

Caution: Temperature should not exceed 140 °F (60 °C) during 30 minutes in order to avoid distortion.

Cut fiberglass cloth with scissors or tin snips, 1 to 3 inches (25-75 mm) larger than area to be repaired. Build area to desired height.

Mix resin and hardener following instructions on their containers. Saturate layers of fiberglass with mixture and place laminates over damaged area. Smooth out wrinkles and make sure general contour of area is maintained. Bubbles and wrinkles can be eliminated with a roller.

Caution: The pot life of the mix is approximately 15 minutes. Any accidental contamination to the skin, clothing, tools, etc. must be removed within this period. Use acetone to remove uncured resin.

Heat resin material again by placing heat lamps 18 to 24 inches (450-610 mm) from repaired area. Allow 12 to 15 minutes for repair to cure. After repair is cured, grind, file or sand to contour. Files other than body files may be more suitable. Featheredge and finish sanding.

If small pits or irregularities appear after making repair, correct by using a liberal amount of chopped strand or filler mixed with resin to form a paste. Refer to heading "Repair with Fiberglass Paste" in this section.

4.2 REPAIR USING FIBERGLASS PASTE

Fiberglass paste is used for repairing small dents, scratches, and pits. Paste is made by mixing resin, hardener and fiberglass strand or filler to the consistency of putty. Where necessary, sand paint away around damaged area. On underside of coach, scrape away undercoating from damaged area, and wipe clean with solvent.

Preheat the area to be repaired using heat lamps. Mix desired quantities of resin and hardener according to manufacturer's instructions. Add powdered fiberglass strand into mixture to thicken it into a putty state.

Section 18: BODY

Note: If repair is made on a vertical surface, adding powdered filler material to mixture will reduce tendency of hot resin to flow or run.

Apply the material with a putty knife or similar object, building material up to the desired contour. For deep filling and on vertical surfaces, several layers of material may be used.

A hacksaw blade, held flat to adjacent contour and then moved in a sawing action across the repair when the resin is in a gel state, will remove excess resin from repair. Finish repair with the same procedure as when using fiberglass cloth.

4.3 TYPICAL FIBERGLASS REPAIR PROCEDURE

Remove all loose particles or damaged material using a power sander or rasp. Clean area, overlapping hole approximately 1" to 1-½" (25-40 mm) all around. Remove all dirt, grease and paint from area to ensure good bonding surface. Feather the cleaned area all around (Fig. 4).

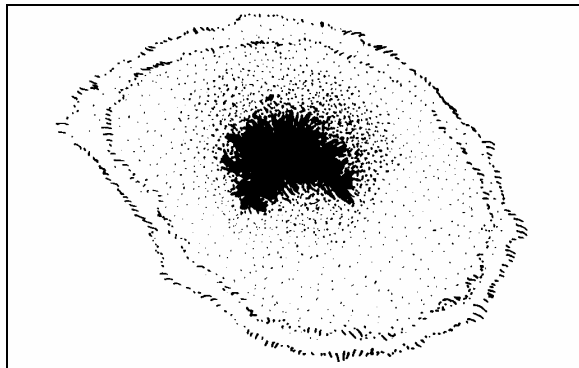

FIGURE 4: FIBERGLASS REPAIR

18089

Cut a piece of fiberglass mat slightly larger than area being repaired. Impregnate mat with general purpose polyester resin catalyzed normally. Use a clean paint brush to apply the polyester resin. Apply impregnated mat over hole and press onto surface with brush to obtain good adherence. Another coat of general purpose polyester resin can be applied at this time (Fig. 5).

Note: Remove all air between surfaces being joined. Allow area to harden and sand surface to remove any wax.

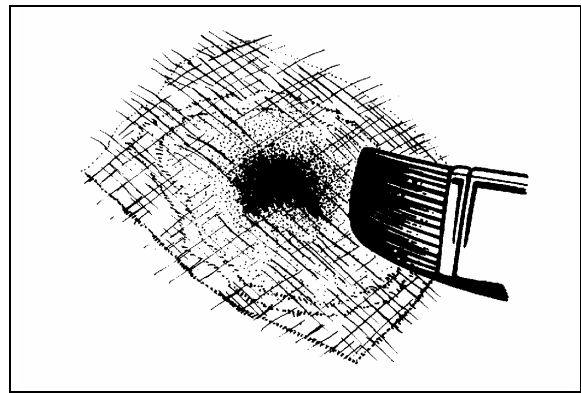

FIGURE 5: FIBERGLASS REPAIR

18090

Apply another mat, followed by a cloth patch, and another mat. All layers must be thoroughly impregnated with polyester resin, brushed well and free of air. Apply more layers of mat and cloth as required until the desired strength and thickness is obtained, minimum two 1-½ oz (43 g) mats and one 9 oz (255 g) cloth (Fig. 6).

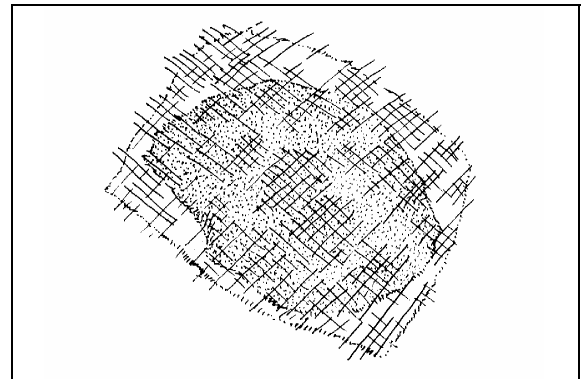

FIGURE 6: FIBERGLASS REPAIR

18091

Allow area to harden and contour the area with coarse sandpaper #100 (Fig. 7).

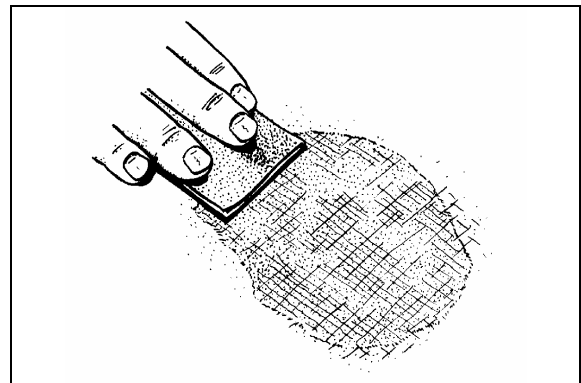

FIGURE 7: FIBERGLASS REPAIR

18092

Cover the area with a layer of resin putty and allow drying for approximately 15 to 20 minutes (Fig. 8).

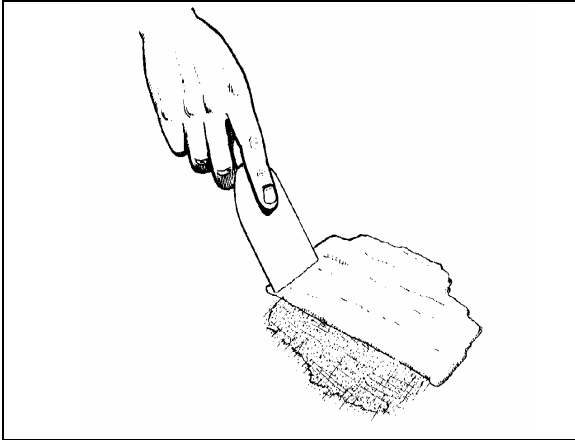

FIGURE 8: FIBERGLASS REPAIR

18093

Smooth off surface with coarse sandpaper #100 to desired shape. Further smooth surface with fine sandpaper #120 until repaired surface matches surrounding area paneling. Prime and paint the area to match surrounding paintwork.

5. PAINTING

5.1 NEW PAINT CARE

Our paint supplier recommends that you follow these simple precautions the first months of your new vehicle's life.

Caution: Apply these recommendations after repainting vehicle.

During the first 30 days:

- Do not use a commercial bus wash. Stiff brushes or sponges could mar the finish and damage the surface. Wash the vehicle by hand only and with cool water and a very mild bus wash solution. Be careful to use only a soft cloth or sponge;
- Wash vehicle in the shade, never in direct sunlight;
- Do not "dry wipe" vehicle –always use clean water. Dry wiping could scratch the finish;
- Avoid extreme heat and cold. Park vehicle in the shade whenever possible;
- Do not park under trees which drop sap or near factories with heavy smoke fallout. Tree sap and industrial fallout may mar or spot a freshly painted surface;
- Trees are also likely to attract birds. Bird droppings are highly acidic and will damage a freshly painted surface. Bird droppings,

tree sap and industrial fallout should be washed off as soon as possible;

- Do not spill oil, gasoline, antifreeze, transmission fluid or windshield solvent on new finish. IMMEDIATELY rinse off any such spill with clean water, DO NOT WIPE;
- Do not drive on gravel roads. Paint finish easily chips during the first 30 days;
- Do not scrape ice or snow from the surface. A snow scraper can act like a paint scraper if the finish is new. Brush off loose material with a soft snow brush.

During the first 90 days:

- Do not wax or polish the vehicle. This will allow the finish to dry and harden completely.

5.2 PAINT TOUCHUP

When paint touchup or partial repainting is necessary, refer to the vehicle's paint scheme for color codes and paint brand.

Prévost recommends using the original paint brand to ease color matching.

In the event you sand through to the gelcoat surface you should prime the area with Standox "Non Stop Fill Primer (ST-11000)".

If you sand through to metal surface, first prime with Standox "Etch Primer (ST-11858)" then with Standox "Non Stop Fill Primer (ST-11000)".

Caution: Be sure to heed all paint manufacturer's recommendations, especially concerning paint dilution and application.

5.3 PAINTING

The standard paint used on the exterior of the vehicle is Standox Basislack. It is a high gloss polyurethane enamel finish designed for exposure to extreme conditions. Other types of paint may be called for as options by owner but are not dealt with in this section.

5.3.1 Safety

Care should be exercised in storing, handling, mixing, and applying paint and chemicals listed in this manual. The topcoat, primer, solvent, catalysts, accelerators, and cleaners are highly volatile and/or toxic if not properly used. Observe all safety instructions marked on the different packagings, as well as the following:

Section 18: BODY

1. Do not smoke in the paint room or in adjacent area exposed to residue fumes.
2. Wear respirators approved by the governing safety and health regulations.
3. Maintain adequate ventilation at all times.
4. Dispose of any leftover paint mix properly.
5. Wear rubber gloves, rubber apron, and face shield during all phases of paint and chemical handling.

5.3.2 Surface Preparation and Paint Application

	Aluminum and / or Stainless Steel	Fiberglass	Comments
Surface Preparation	Sand using P-150 grit sandpaper. It is recommended to sandblast rivets and panel edges with OLIMAG 35-70 blast media.	Sand using P-180 or P-240 sandpaper.	Do not use paint remover over aluminum or fiberglass.
Cleaning	STANDOX silicone remover ST-11654 (68-2989)		
Priming	STANDOX Reactive Etch Primer ST-13908 * Wait 30 minutes then apply STANDOX Non-Stop Füllprimer ST-11000 (68-2973)	STANDOX Non-Stop Füllprimer ST-11000 (68-2973)	Refer to product Technical Data sheet for proper mixing
Basecoat	Refer to paint scheme or coach record for proper color code and paint brand. We recommend using the same paint brand to ease color matching.		Refer to product Technical Data sheet for proper mixing
Clearcoat	STANDOX 2K MS Rapid Clear ST-11760 (68-2979) Allow 16 hours for drying		Refer to product Technical Data sheet for proper mixing

If assistance or technical information on STANDOX products is needed, please dial: 1 (800) 551-9296

5.4 FRONT AND REAR BUMPERS

5.4.1 Paint touchup and surface preparation for vehicles equipped with urethane bumpers

	COMMENTS	VIP	COACHES
Cleaning	Clean using red wool and Standoflex 11100 (ST-11425) thinner	YES	YES
	Clean again twice using Standoflex 11100 (ST-11425) thinner	YES	YES
Priming	Apply Non-Stop primer (ST-13320) with flexible agent dilution 2:1 10% in 2 or 3 coats, 15 min. flash/off between coats	YES	YES
Sanding	Sand Non-Stop primer using P-320 grit sandpaper	YES	YES
	Use a tack cloth	YES	YES
Basecoat	Apply basecoat. Wait 30 minutes.	YES	YES
Varnish dilution	Dilution without flexible agent	YES	YES
Varnishing	Apply varnish	YES	YES

If assistance or technical information on STANDOX products is needed, please dial: 1 (800) 551-9296

6. FRONT AND REAR BUMPERS

6.1 FRONT BUMPER REMOVAL AND INSTALLATION

The front bumper is hinged to give access to the spare wheel compartment. Bumper must first be tilted down before its removal. Two people are required to remove and install the front bumper.

Warning: Front bumper weighs approximately 180 lbs. (80 kg). Use proper lifting equipment to support the bumper during the removal and installation operations to avoid personal injury.

Pull on the release handle located in the front electrical and service compartment to access the spare wheel compartment.

The bumper assembly will lower gradually.

6.1.1 Molded Front Bumper Removal

Loosen 12 attaching bolts from inside the bumper, 6 near the top and 6 in the middle. (Fig. 9). Let the bumper rest face down on the lifting equipment platform.

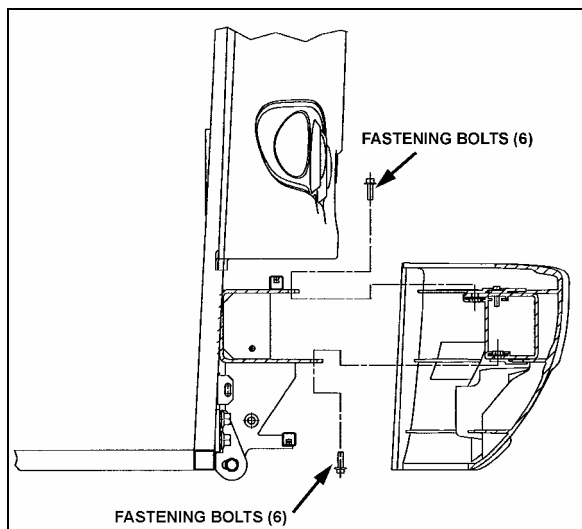

FIGURE 9: BUMPER FASTENING MECHANISM 18498

To install molded front bumper, reverse the procedure.

6.1.2 Front Bumper Assembly Removal including spare wheel compartment door

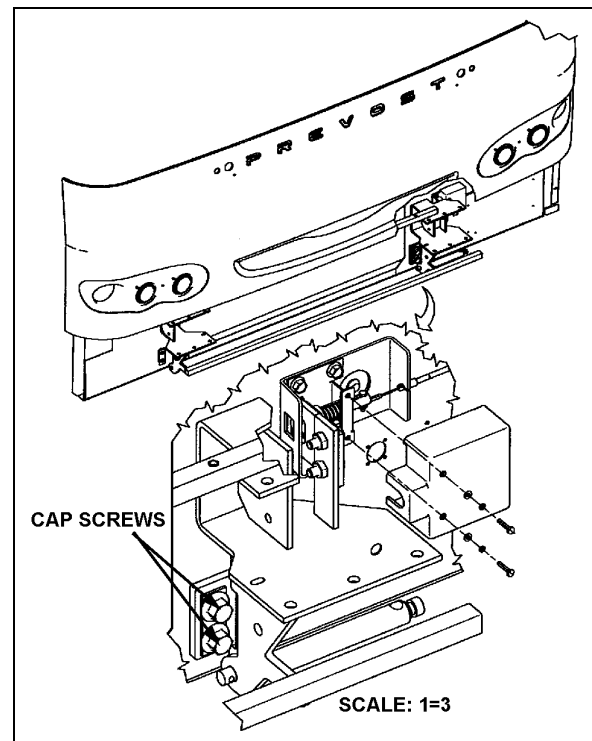

FIGURE 10: FRONT BUMPER ASSEMBLY 18499

1. Ask assistant to relieve spring tension with assistant proper tool, and relieve spring tension on one locking pin and remove it. Slowly release spring tension and remove the second locking pin. The spring is free. Repeat procedure for the other spring.

Note: A special tool kit is available from Prévost Car Inc: Kit # 410671 including tool #410708.

2. Remove 4 cap screws holding bumper to vehicle and remove bumper (Fig. 10).
3. To install bumper, reverse the removal procedure.

6.2 FRONT BUMPER LICENSE PLATE SUPPORT INSTALLATION

License plate supports are stored in the first baggage compartment.

Install supports using dedicated holes as per figure 11.

Section 18: BODY

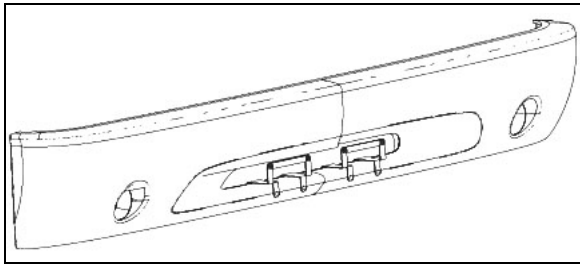

FIGURE 11: LICENSE PLATE SUPPORTS 18500

6.3 REAR BUMPER REMOVAL AND INSTALLATION

Warning: Rear bumper weighs approximately 180 lbs. (80 kg). Use proper lifting equipment to support the bumper during the removal and installation operations to avoid personal injury.

1. Remove 6 nuts (3 on each side) holding bumper assembly to vehicle and remove bumper (Fig. 12).
2. Let the bumper rest face down on the lifting equipment platform.
3. To install bumper, reverse the procedure.

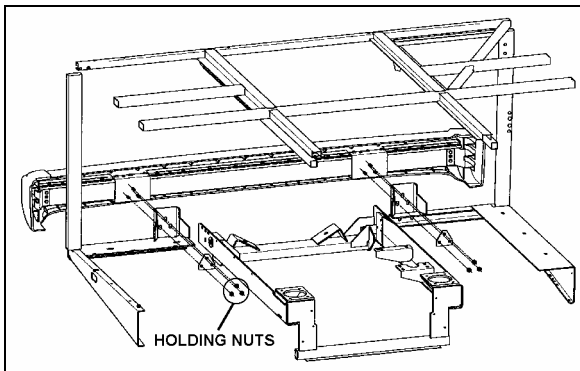

FIGURE 12: REAR BUMPER ASSEMBLY 18501

7. COACH ENTRANCE DOOR

An air operated “sedan type” entrance door, with an air door cylinder and damper assembly are installed under the right hand dash. The opening and closing door speed cycle is adjustable by a damper mounted in parallel with the door cylinder on the door hinge (Fig. 15). Door activation is controlled by a relay panel, located near the defroster and wiper motors. The accessory air reservoir supplies air to this system.

The door is held in the closed position during coach operation by two air cylinder locking mechanisms (Fig. 16). Air cylinders with return

spring in the cylinder body are used. Air cylinders are controlled by an electrically operated solenoid valve energized by a rocker switch located under the right hand dashboard.

To open the door, initial movement of the rocker switch de-energizes the air lock solenoid valve, venting the door locking cylinders. The return locking spring pulls the door lock away from the latch, unlocking the door. Door movement starts only when pressure in the central air door lock is below 10 psi. The “air cylinder open solenoid valve” opens and allows air to flow to the door cylinder, “the air cylinder close solenoid valve” exhausts air from the rod side of the cylinder.

To close the door, initial movement of the switch energizes the “air cylinder close solenoid valve” and air flows to the cylinder by its rod side port. The “air cylinder open solenoid valve” exhausts air from cylinder. When entrance door latch is grounded with the door frame, the air lock solenoid valve is de-energized and loads the door lock cylinders. The cylinder moves the door lock in a position which engages a latch on the entrance door, holding the door positively closed.

Emergency exit valves, which open the air valve circuit, should be used only in emergencies, or when the door control system does not function properly.

Refer to the air system schematic diagram annexed at the end of section 12, “Brakes” and to page 22 of the wiring diagram.

7.1 OPERATION

The air-operated door is controlled from inside the coach by two push-button switches located on the R.H. dashboard.

Opening and closing of the door from outside the coach is accomplished by a momentary toggle switch located behind the coach model nameplate (Fig. 13).

To close the door, the switch must be pushed towards the rear of the coach and held in position until the door has completed its movement.

To open the door, the switch must be pushed towards the front of the coach and held in position. When the door reaches the fully opened position, the system will keep pressure in the cylinder locking the door in that position. The door can be stopped in any position by

releasing the switch. The door is not locked in position when not fully opened or closed.

If the door has been locked with the key, a lever on the door can be moved to unlock.

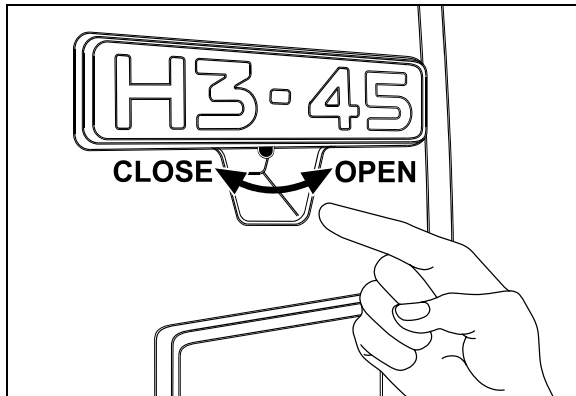

FIGURE 13: DOOR OPERATING SWITCH 18316

7.2 EMERGENCY EXIT VALVES

From inside the vehicle, an emergency exit valve located near the door on the dash panel, releases the pressure from the lock cylinders. From the exterior, an emergency exit valve located in the front service compartment, also releases the air from the lock cylinders.

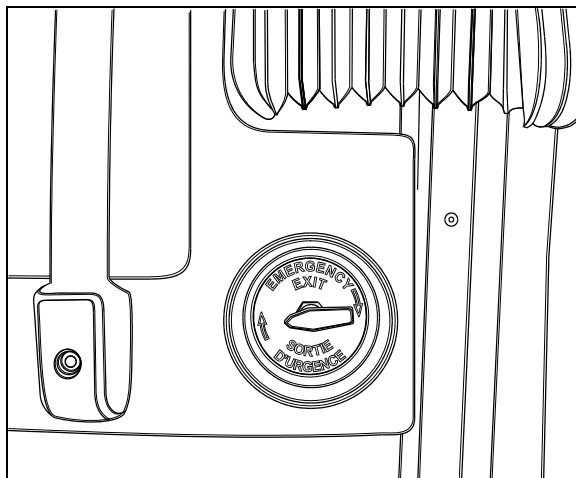

FIGURE 14: EMERGENCY EXIT VALVE 18321

7.2.1 Without Air and/or Without Electricity

If the air pressure drops while coach has or hasn't any electricity, the spring loaded cylinders will unlatch the door. In such a case, unlock the door by moving the lever on the door or by using the key, then open the door manually.

7.2.2 With Air but Without Electricity

From inside the vehicle, turn the emergency exit valve to the "UNLOCK" position. Move the lever. From the exterior, turn the emergency exit valve to the "UNLOCK" position. Open the door. Close it, lock with the key and reset the outside emergency exit valve to the "NORMAL" position.

7.3 DOOR CYCLE SPEED ADJUSTMENT

To do any adjustment, remove the two panels located next to the door hinge, as well as the door's upper hinge control.

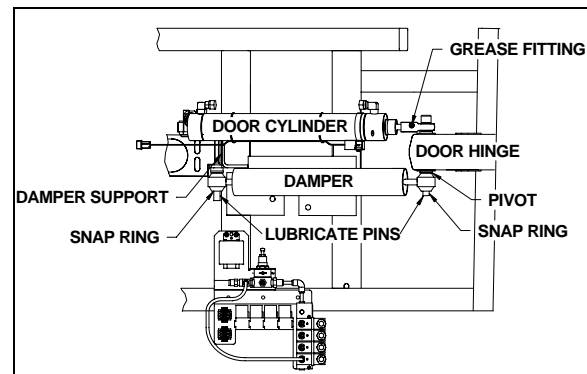

FIGURE 15: DOOR CYLINDER AND DAMPER 18161

Caution: It is important to make sure that damper does not reach end of stroke when door is completely closed or opened. The door cylinder must stop the door on opening. Screw or unscrew rod end to adjust if necessary.

To adjust opening and closing cycle speed on damper (Fig. 15):

1. Remove the damper from the vehicle and hold it vertically with the lower eye or pin attachment in a vice. Use clamp plates to prevent damage.
2. Fully close the damper while turning the dust cap or piston rod slowly CCW until it is felt that the cams of the adjusting nut engage in the recesses of the foot valve assembly (Fig. 17).

Note: In figure 17, if there is an indentation (B) in the dust cap (C) and the cover shows two holes (A), the damper is fitted with a bump rubber (D). If so, fully extend the damper and insert a round bar or screwdriver through the holes. Push the bump rubber down and remove. Remove the split plastic collar (E) (if fitted) from the piston rod.

Section 18: BODY

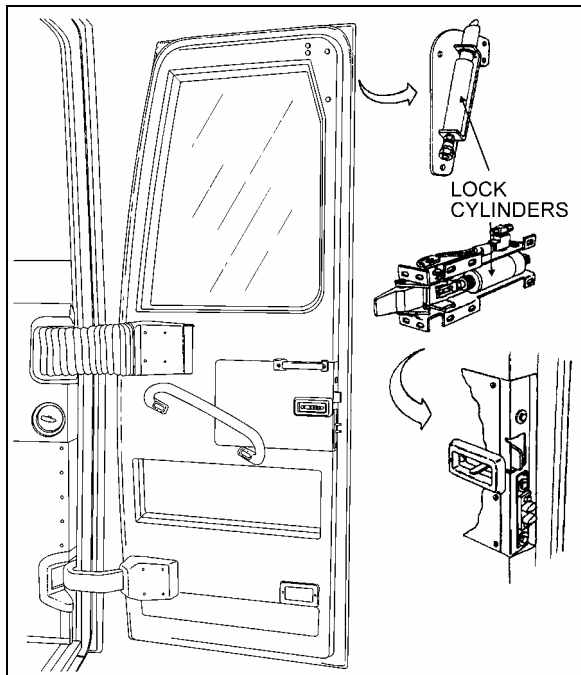

FIGURE 16: COACH ENTRANCE DOOR

18439

3. The damper may have already been adjusted. Therefore check whether the damper is adjusted or not by keeping it closed and gently turning further CCW, counting at the same time the half-turns until a stop is felt. Stop turning and do not force.
4. While keeping the damper closed, make two CW half-turns. In case of prior adjustment, add the number of half-turns previously counted. The total range is about five half-turns.
5. Pull the damper out vertically without turning for at least 3/8" (1cm) to disengage the adjusting mechanism. The dust cap or piston rod may now be turned freely.

Note: Where a bump rubber was installed, refit same inside the dust cap and by fully closing the damper, the rubber will seat again at top of the dust cap. Refit the split plastic collar E (Fig. 17)

6. The damper can now be refitted in the vehicle.
7. Reinstall panels and entrance door hinge cover.

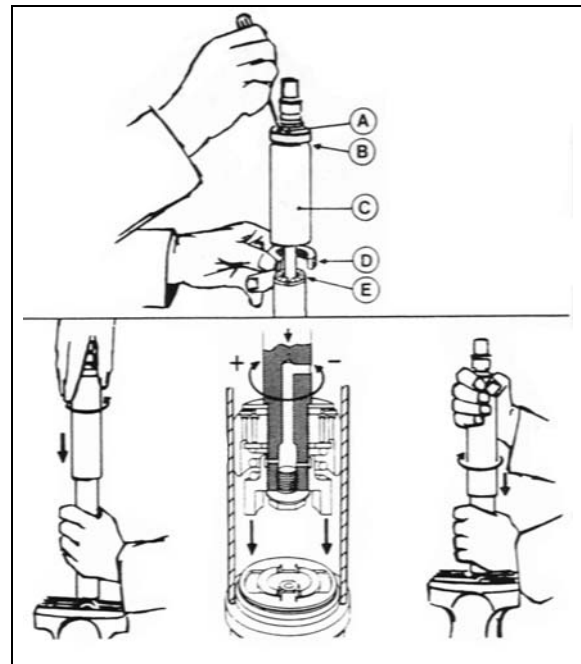

FIGURE 17: DAMPER

7.4 HORIZONTAL AND VERTICAL ADJUSTMENT

Before attempting to correct any door operating problem by adjusting any part of the air cylinder assembly, first perform the following mechanical checks and procedure.

Check around the perimeter of the door for binding. If any binding is found, adjust as follows:

1. Remove the screws and the plastic molding covering each of the hinges.

Note: Ask an assistant to help you to perform the following adjustments.

2. Remove the Allen button head screw and the washer retaining the rod end with bearing to the upper hinge. See figure 18.
3. Support the door with a wooden block and a hydraulic jack.
4. Loosen the horizontal bolts retaining the door to the hinges. Adjust the door horizontally and vertically with the jack. Tighten the bolts to 30-36 Ft-lbs (40-50 Nm). Remove the jack and the wooden block.

Caution: Make sure the entrance door does not interfere with the exterior panel.

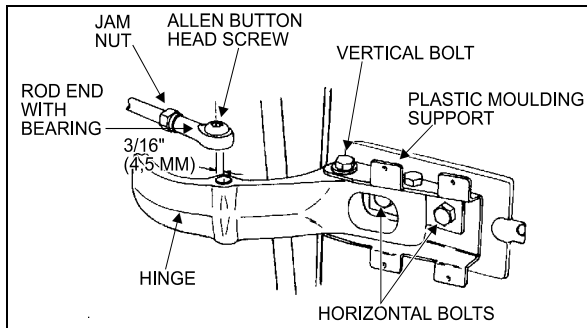

FIGURE 18: UPPER DOOR HINGE (COACH) 18058

5. Pull and fasten the rod end to the hinge with the washer and the button screw.
6. Screw the plastic moldings covering the hinges.

7.5 DEPTH ADJUSTMENT

1. Turn the emergency exit valve to the "UNLOCK" position.
2. Remove the screws and the plastic molding covering each of the hinges.

Note: Ask an assistant to help you to perform the following adjustments.

3. Remove the Allen button head screw and the washer retaining the ball and socket rod to the upper hinge. See figure 18.
4. Loosen the vertical bolts on the hinges for the front section, and for the rear section, move the central door catch on the door frame.
5. To adjust the male dovetail on L.H. side of the door, remove the two screws and loosen the two bolts. Slide the male dovetail toward the interior and loosely tighten the two bolts. Close the door slowly but firmly, then slowly open it and tighten the two bolts. Attach dovetail to the door with screws. See figure 19.

Note: The frame dovetail is not adjustable.

6. Pull and fasten the rod end to the hinge with the washer and the button screw.
7. Using the screws, attach the plastic moldings covering the hinges.
8. Reset the emergency exit valve to the normal position.

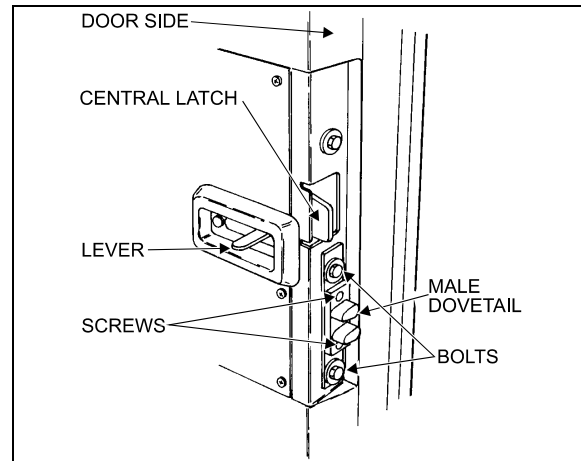

FIGURE 19: DOOR LATCH (COACH) 18059

7.6 ROD END ADJUSTMENT

1. Turn the emergency exit valve to the "UNLOCK" position.
2. Remove the screws and the plastic moldings covering the upper and lower hinges.
3. Remove the Allen button head screw and the washer retaining the rod end with bearing to upper hinge. See figure 18.
4. Loosen the jam nut locking the door cylinder rod end. Close the door firmly, adjust the rod end center hole in order to be 3/16" (4,5 mm) eccentric toward the left with the hinge hole center. Tighten the jam nut.
5. Pull and fasten the rod end to the hinge with the washer and the button screw.
6. Using the screws, attach the plastic moldings covering the hinges.
7. Reset the emergency exit valve to the normal position.

7.7 LUBRICATION

Part	Lubricant	Frequency
Latches Upper door catch Door cylinder rod end with bearing grease fitting (Fig. 15)	Low temperature grease	Every six months
Door locking mechanism	White grease	Every six months
Key hole Damper pins (Fig. 15) Hinges	Low viscosity oil	Every six months

Section 18: BODY

7.8 TROUBLESHOOTING

SYMPTOM	PROBABLE CAUSE	REMEDY
DOOR WILL NOT OPEN FROM EXTERIOR SWITCH.	Manual door locks engaged.	Release manual door locks.
	Upper and lower solenoid locks do not disengage.	Check voltage at solenoid locks when door is open. If the voltage is 24 volts then replace solenoid #641217. Else, check circuit power.
	Relay module do not receive current.	Reset breaker "ON" or check batteries power supply.
	Opening solenoid door does not receive current.	Check voltage at opening solenoid door. If the voltage is 24 volts then replace it. Else replace control relay.
	Switch malfunction.	Replace switch.
DOOR WILL NOT CLOSE FROM EXTERIOR SWITCH.	Switch malfunction.	Replace switch.
	Solenoid failure.	Check voltage at solenoid. If the voltage is 24 volts then replace solenoid. Else replace control relay.
DOOR WILL NOT OPEN FROM INTERIOR SWITCH.	Manual door locks engaged.	Release manual door locks (open position) from vehicle exterior.
	Upper and lower solenoid locks do not disengage.	Check voltage at solenoid locks when door is open. If the voltage is 24 volts then replace solenoid #641217. Else, check circuit power and replace control relay.
	Module relay does not receive electric current.	Reset breaker "ON" or check batteries power supply.
	Door opening solenoid does not receive current.	Check voltage at door opening solenoid. If the voltage is 24 volts then replace it. Else replace control relay.
	Switch malfunction.	Replace switch.
	Upper lock stays engaged.	Lubricate upper lock assembly. Check wear and replace parts if necessary.
DOOR WILL NOT CLOSE FROM INTERIOR SWITCH.	Switch malfunction.	Replace switch.
	Door closing solenoid does not receive electric current.	Check voltage at door closing solenoid. If the voltage is 24 volts then replace it. Else replace control relay.
DOOR WILL NOT OPEN AFTER DRAINING AIR FROM SYSTEM BY EMERGENCY VALVE(S).	Manual door locks engaged.	Release manual door locks (open position) from vehicle exterior.
	Damper cylinder blocks the door.	Adjust or replace damper cylinder.
	The upper lock blocks the door	Adjust lower lock. Lubricate upper latch bolt. Adjust upper latch height.
DOOR LOCKS STAY ENGAGED WHEN DOOR IS OPEN.	Power supply is cut at solenoid.	Place switch in open position.
	Solenoid lock does not disengage.	Check voltage at solenoid locks when door is OPEN. If the voltage is 24 volts then replace solenoid #641217. Else, check circuit power and replace control relay.
DOOR DO NOT LOCK WHEN DOOR IS CLOSED.	Emergency valve is open.	Close emergency valve.
	Lock solenoid stays electrified.	Check latch bolt ground on door frame. If needed clean locks for better contact. Check ground circuit.
	Lock solenoid works in reverse.	Reverse air hoses at solenoid locks.
	Relay does not function.	Replace relay.

8. ENTRANCE DOOR (V.I.P)

There are three ways of unlocking the entrance door from the inside of vehicle. The two first consist in actuating the rocker switch on the dashboard, but this last operation will also unlock the baggage compartments. Finally, you can unlock the door by sliding its lock lever to the left. If the orange tab on the door lock lever is visible, the door is unlocked.

You may lock/unlock the entrance door from the outside with the lock key provided with the vehicle. Turn key CCW to lock and CW to unlock the entrance door.

8.1 KEYLESS ENTRY SYSTEM

With this system, you can lock or unlock the entrance door as well as the baggage and service compartment doors. The keyboard is located below the entrance door handle. The module is pre-programmed by the manufacturer and this code can not be deleted. Moreover, you can program your own entry code. Refer to the "VIP Owner's Manual" for instructions on how to program your own entry code.

When you use the keyless entry system, the keyboard and stepwell lights illuminate. Do not push the buttons with a key, pencil or any other hard object as it could damage the buttons.

Although each button is provided with two digits separated by a vertical line, there is only one contact per button. Always press the center of the button (between the two digits, on the vertical line).

If you let more than five seconds pass between each button press, the system shuts down, and you have to enter your code again. If the keyless entry system does not work properly, use the key to lock or unlock entrance or compartment doors. To know more about the keyless system, refer to the "VIP Owner's Manual".

Note: You must unlock the entrance door before you unlock with the appropriate key any baggage or service compartment doors.

8.2 DOOR ADJUSTMENT

Check around the perimeter of the door for binding. If any binding is found, adjust as follows:

8.2.1 Horizontal and Vertical Adjustments

1. Remove the screws and the plastic molding covering each of the hinges.

Note: Ask an assistant to help you to perform the following adjustments.

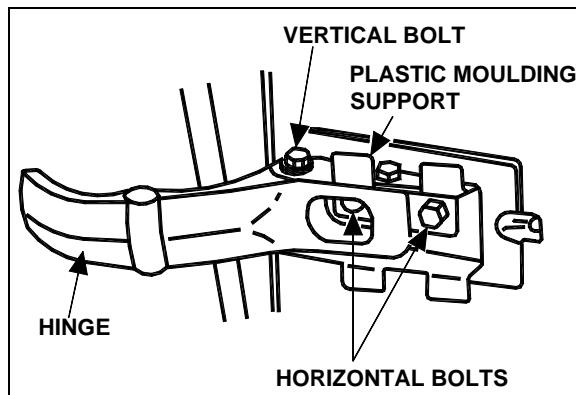

FIGURE 20: ENTRANCE DOOR (VIP)

18058VIP

2. Support the door with a wooden block and a hydraulic jack.
3. Loosen the horizontal bolts retaining the door to the hinges. Adjust the door horizontally and vertically with the jack. Tighten the bolts to 30-36 Ft-lbs (40-50 Nm). Remove the jack and the wooden block.
4. Check door fit.
5. Using the screws, fasten the plastic trim to cover the hinges.

8.3 DEPTH ADJUSTMENT

To adjust door depth on the hinged side:

1. Remove the screws and the trim covering each of the hinges.

Note: Ask an assistant to help you to perform the following adjustments.

2. Slightly loosen, but not completely the vertical bolts on both door hinges.
3. Ask your assistant to press the door from the exterior, until it will adjust with the vehicle structure. Then, tighten the vertical bolts.
4. Repeat step 3 until depth is corrected to satisfaction.
5. Using the screws, install the trim hiding the hinges.

To adjust door depth on lock side:

Depth adjustment is done by moving the two door strikers.

1. Slightly loosen the door strikers.
2. Ask your assistant to press the door from the exterior, until it will adjust with the vehicle structure. Then tighten the striker pin.
3. Repeat until the door depth is corrected to satisfaction.

8.4 DOOR LOWER SECTION

When a plastic door lower section replacement is needed, proceed the following way:

1. Remove the reflective stripe at the top edge of the door's lower section. Unscrew the retaining screws located under the reflective stripe.
2. Remove the lower section.
3. With a sharp edge knife, scrape as much tape as possible and compound left on the fiberglass door surface. Note where adhesive tape and sealing compound was applied.
4. Sand the surface of the door where new adhesive tape will be applied with 240 grit sandpaper.

Note: *Tape adheres best to smooth surfaces such as glass or gelcoat finishes. Be careful surface is as smooth as possible before applying tape.*

5. Clean contact surfaces with alcohol.
6. Clean the fiberglass door and the new plastic lower section with a "tack cloth". Make only one pass on the surface and never come back on a previously cleaned surface.

Caution: *Wear rubber gloves and do not smoke when cleaning.*

7. Prepare the door lower section with Sika #205 and a clean rag. Make only one pass on the surface and never come back on a previously cleaned surface.

Note: *Never use Sika #205 directly from the container to avoid contamination of the product.*

8. Wait at least 5 minutes before proceeding the next step to allow complete evaporation of the product.
9. Put new adhesive tape where it was previously applied. Pass a 1" (25mm) roller on it to get a good adhesion on the fiberglass.
10. Apply Sika #252 (Prévost #682462) compound where it was previously applied.
11. Remove protective paper from the adhesive tape and install the door lower section. Apply pressure with a roller where the lower door section touches the fiberglass door.
12. Replace the retaining screws.

8.5 REFLECTOR STRIPE INSTALLATION

1. Clean contact surfaces with alcohol.
2. Prepare surface of reflector stripe and door lower section with Sika #205.
3. Put two rows of adhesive tape on the lower door section.
4. Apply Sika #252 (Prévost #682462) compound between parallel tape stripes.
5. Remove protective paper from the adhesive tape and press the reflective stripe in place.

8.6 DOOR SEAL REPLACEMENT

1. Inspect the seal; if cracked or torn, it must be replaced:
2. Remove the old seal and with a sharp edge knife, scrape tape left on the fiberglass door surface.
3. Sand the surface of the door where a new seal will be applied with 240 grit sandpaper.
4. Clean the surface with alcohol.

Caution: *Wear rubber gloves and do not smoke when cleaning.*

5. Peel of protective paper from the seal. Position the seal in order to leave ¼" (6 mm) from the upper molded edge of the door and 3/16" (4,5 mm) from the sides and lower molded edges of the door.
6. Progress slowly all around the door.
7. Cut the seal and glue both ends with LOCTITE 414 glue.

- To assure bonding, press a small roller on top of the new seal.

8.7 DOOR LUBRICATION

Part	Lubricant	Frequency
Latches Upper door catch	Low temperature grease	Every six months
Door locking mechanism	White grease	Every six months
Key hole Hinges	Low viscosity oil	Every six months

8.8 DOOR LATCH MECHANISM

Generally, when the latch mechanism malfunctions, a number of causes may be responsible for this situation. No single procedure will correct this situation. It is best to remove the protective cover and to look for binding, used or bent parts. Operate the latch mechanism and try to find where any binding occurs. Replacing a part or slightly bending a rod should be enough. Remember, having a global understanding of the mechanical activity will generally lead you to the cause of the problem, and ultimately to an easy repair.

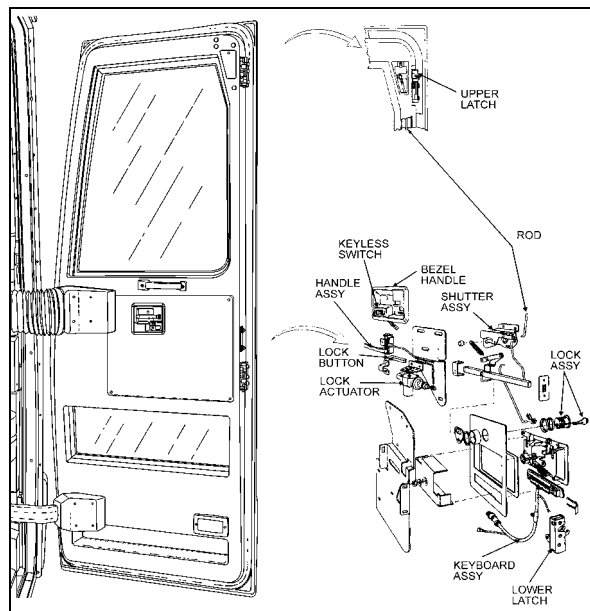

FIGURE 21: ENTRANCE DOOR (VIP, TYPICAL)

18440

9. DRIVER'S POWER WINDOW

To replace window or motor, the whole assembly must be removed. The following instructions refer to figure 22.

9.1 WINDOW OR REGULATOR REMOVAL

- Remove the L.H. console and instrument support plate behind it.
- Remove the screws holding the window to the lifting mechanism. Remove the holding plate.
- Lower the window support assembly while holding the window in the closed position to detach the regulator assembly from the window.
- Remove the four bolts holding the motor and regulator assembly in place.
- Detach the plastic water protection shield (30).
- Remove the assembly by slipping it under the vehicle structural members.
- Lower the window completely to detach from the opening.

9.2 WINDOW OR REGULATOR INSTALLATION

- Detach the notched strip from the regulator's sprockets with a screwdriver and reinsert it two notches back so the sliding window support will go further down the post than normal.
- Power the regulator so the support goes down to its lowest position.
- Cut the excess notched strip.
- Remove the screws holding the plate (3). Remove the plastic water protection shield (30).
- Using alcohol, a sharp knife or 240 grit sandpaper, clean off the butyl tape from the shield and frame. Install new tape on shield.
- Insert the shield over the new mechanism.
- Screw the plate loosely (3) in place. Use three washers on each bolt to ease final adjustments.
- Install new window in opening

Section 18: BODY

9. Install the regulator assembly and fasten loosely using the bolts recovered from disassembly. Do not install third (right most) bolt (15) yet.
10. Expose the other sticky side of the butyl tape and stick shield in place.
11. Connect the regulator motor.
12. Raise the window support to so it mates with the slightly lowered window.
13. Fasten window to regulator assembly loosely using the anchor plate and recovered bolts.
14. Raise window to closed position and tighten anchor plate bolts.
15. Lower window completely, then raise it to mid-open position. Tighten plate (3) bolts (9).
16. Raise window to nearly closed position and check if it is level with the top of the window opening.
17. If the window is level, tighten the two left bolts (15) and screw in the third right bolt (15).
18. If window glass is not straight, tilt up or down regulator assembly before tightening bolts.

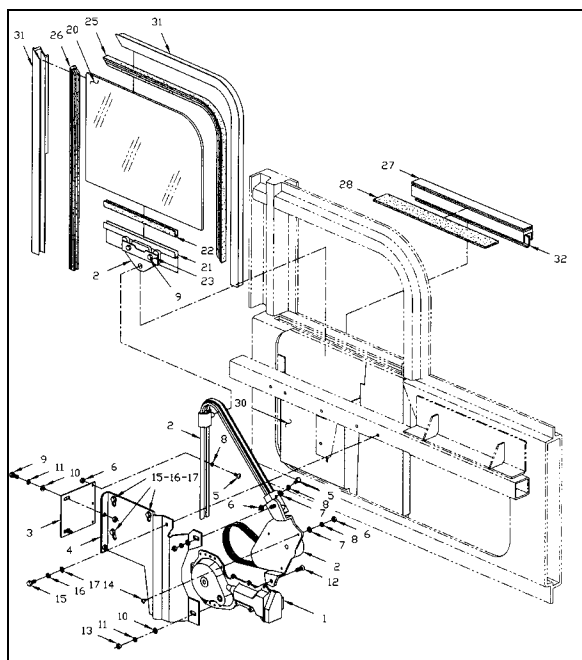

FIGURE 22: DRIVER'S WINDOW

18322

10. ROOF ESCAPE HATCH

The vehicle can be equipped with one or two escape hatches. The escape hatch is designed to provide years of reliable service with a minimum of maintenance. All components are rust proof, and moving parts are Teflon coated to eliminate need for lubrication. Should water infiltrate the vehicle from the escape hatch, refer to the heading "Sealing" in this section for procedures on how to seal this area.

Caution: Use of lubricants, paints, or other coatings such as graffiti deterring sprays are not recommended.

Suggested maintenance includes periodic inspection of fasteners for evidence of loosening due to tampering, and regular cleaning with mild soap and water.

Although there are other cleaning solutions available, some contain solvents and other chemicals that can attack the high strength materials used in the production of the escape hatch.

Caution: Ensure that cleaning solutions are compatible with the materials used on the escape hatch.

Graffiti removing cleaners often contain acetone, ether, lacquer thinner, or other solvents known to destroy the high strength properties of many plastics. Use of these cleaners must be avoided.

Graffiti-resisting coatings often leave a sticky residue that interferes with smooth up/down movement of the hatch mechanism. Some of these coatings also contain solvents that will reduce the strength of certain components.

Caution: Use of these coatings is at considerable risk and should be avoided.

10.1 REPAIR

All components used in the production of the escape hatch are available as service parts, except for one hinge that represents a possible hazard when improperly reattached to a hidden tapping plate, itself often damaged whenever the hinge is damaged. The tapping plate is permanently laminated between the inner and outer cover assemblies, and it cannot be inspected or replaced. It is therefore necessary to replace the entire assembly following damage to the hinge. See figures 23 and 24.

Caution: Hinge assembly is critical and hinge should never be removed from cover assembly. Fasteners used in this assembly are special and have critical torque requirements and tamper-resistant heads to discourage tampering.

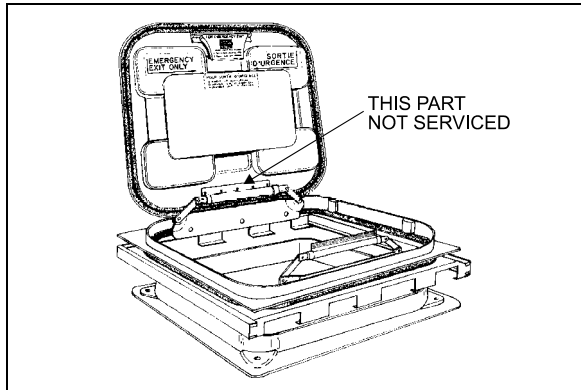

FIGURE 23: ESCAPE HATCH

18104

10.2 SEALING

1. Open and tilt up the escape hatch cover.
2. Join the 2 ends of the rubber seal.

Caution: Seal joint should be toward rear of vehicle.

3. Apply rubber adhesive CA-40 (Prévost # 681285) in the gap between the seal ends.
4. Apply Sikaflex 221 sealant (Prévost # 680532) along the outline of the escape hatch on the roof of vehicle.

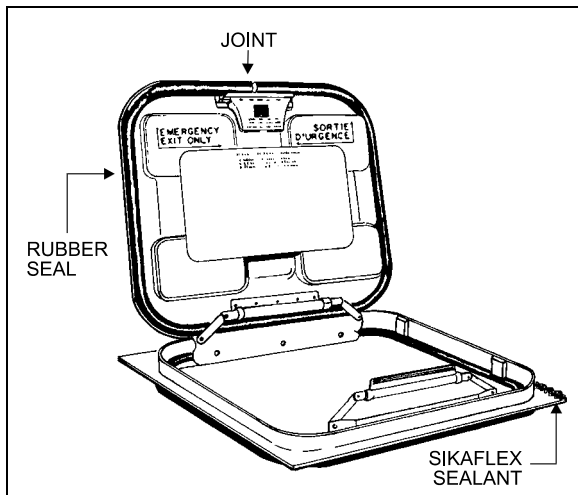

FIGURE 24: ESCAPE HATCH

18105

10.3 ESCAPE HATCH PANEL ASSEMBLY

The frame of the escape hatch is riveted to the roof of the vehicle. The escape hatch panel assembly can be replaced as a unit and a new panel assembly installed in the existing frame. To remove the panel assembly, remove the 4 bolts fastening the 2 hinges to the escape hatch frame and retain the 4 flat washers. Reinstall the panel assembly by fastening the 2 hinges with the 4 bolts and flat washers removed earlier.

Caution: When installing, roof escape hatch's hinge must be toward the front of vehicle, to prevent the hatch from being ripped out if accidentally opened while vehicle is running.

10.4 ESCAPE HATCH FRAME

When necessary, the escape hatch frame can be removed and replaced in the following way:

1. Support the frame from inside the vehicle.
2. Remove rivets.
3. Cut the rubber seal with a sharp edge knife and remove the hatch frame.
4. On vehicle top, using the knife, remove as much as possible the remaining rubber seal.
5. Drill holes (if needed) in the new metal frame.
6. Clean both vehicle top and new hatch frame with SIKA 205.
7. Apply rubber adhesive SIKA 221 under the hatch frame surface.
8. Install the frame in place and fix it with rivets.
9. Remove excess adhesive and clean all around.

Section 18: BODY

11. REPAIR OR REPLACEMENT OF “TARABUS” FLOOR COVERING

“Tarabus” covering installed in H3 coaches may be replaced or repaired. The purpose of this paragraph is to explain the steps to be followed to ensure the best results and adherence.

MATERIAL

Part No	Description	Qty
680028	Adhesive, Tarabus Floor Covering (White)	A/R
684655	Adhesive, Contact (3M)	3.8L
684654	Adhesive, Contact (3M)	18.9L
680532	Sikaflex 221 Gray	A/R

Note : Material can be obtained through regular channels.

1. Remove number of passenger seats required to perform repair.
2. Cut and remove damaged section of floor covering.

Note: It would be preferable to cut under two rows of seats so that repair is not as noticeable.

3. Clean plywood using a scraper.

Note: Make sure that no staples are sticking out beyond surface. Adjacent plywood sheets must be leveled.

4. Fill up holes and imperfections using MAPI PRP 110 then sand.
5. Remove dirt and adhesive residue.

Caution: Do not leave floor covering folded down except temporarily during installation.

6. Apply floor covering adhesive (680028) onto plywood using a serrated spreader with 1/8-inch serration. If required, apply contact adhesive (3M) (684654 or 684655) onto aluminum molding and also onto section of floor covering, which will be in contact with molding (refer to figure 25).

Note: Allow adhesive to dry (3 to 5 minutes).

7. Compress floor covering using a roller so as to remove any trapped air bubble.
8. Apply Sikaflex 221 gray sealant (680532) alongside passenger seat fixing tracks (refer to figure 26).

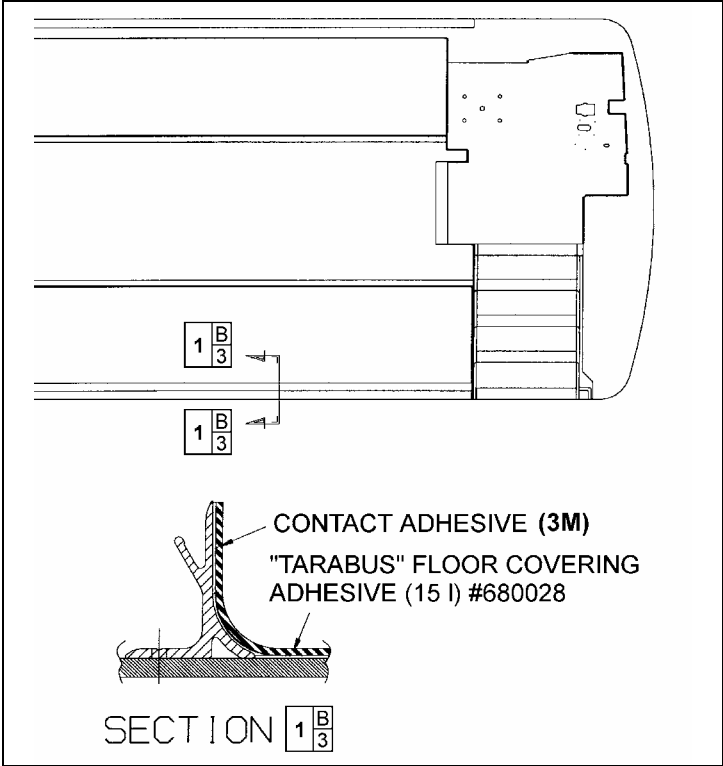

FIGURE 25: TARABUS FLOOR COVERING ADHESIVE APPLICATION

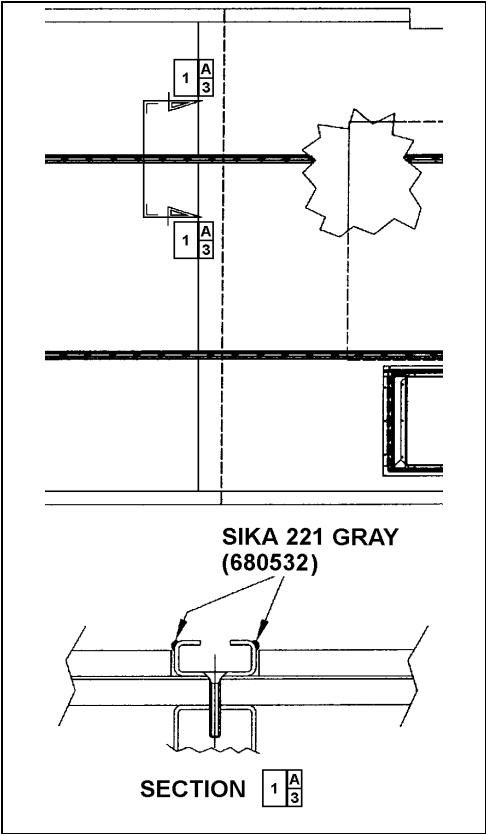

FIGURE 26: APPLICATION OF SIKA 221 GRAY

Section 18: BODY

11.1 FRONT STEPS REPLACEMENT PROCEDURE

MATERIAL

Part No	Description	Qty
682989	Anti-silicone	A/R
683097	Sika 205 (1 liter)	A/R
685101	Sika Remover 208	A/R
683916	Sika 215 (1 liter)	A/R
684654	Adhesive, Contact (3M)	3.8L
684655	Adhesive, Contact (3M)	18.9L
684517	Sealant, gray	A/R

1. Cut and remove damaged step(s).
2. Remove dirt and adhesive residue.

Note: In wintertime, condensation and cold temperature may greatly influenced bonding parameters. Working area must be at a temperature sufficient to prevent reaching condensation point. Mechanically preheat working area (heat lamp or heat gun) or wait until vehicle reaches room temperature.

PREPARATION OF “TARABUS” FLOOR COVERING

1. Sand under step using “Scotchbrite”.
2. Clean using anti-silicone (refer to Section A).

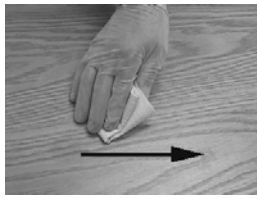
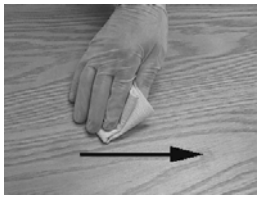
Section A Alcohol or Anti-silicone	
	<p>1. Apply</p> <p>CHIX cloth</p>
	<p>2. Dry immediately</p> <p>Blue cloth</p>
3. Allow drying	
Mandatory	Minimum time : Wait for product to evaporate
	After 2 hours: Start cleaning operation again
Before applying any other product	If surface seems dusty, greasy or with finger marks, start cleaning operation again.

3. Apply Sika Primer 215 (refer to Section D).

Section D Sika Primer 215

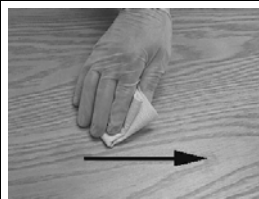

1. Shake bottle to mix product
2. Apply a thin layer

CHIX cloth

3. Allow drying

Mandatory	215	Minimum time : 20 minutes
		After 2 hours : Remove dust using damp cloth (pure water)
Before applying any other product		If surface seems dusty, dust using damp cloth.
		If surface seems greasy or with finger marks, reactivate with Aktivator.

PREPARATION OF FIBERGLASS

1. Clean using anti-silicone (refer to Section A).
2. Apply Sika 205 (refer to Section B).

Section B Sika 205

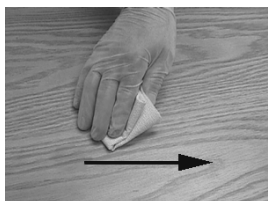

1. Apply

CHIX cloth

2. Allow drying

Mandatory	Minimum time	- For a smooth surface (aluminum, stainless, steel, fiberglass (gelcoat side), etc.):	2 minutes
		- For a porous surface (fiberglass (non gelcoat side), etc.)	10 minutes

After 2 hours : Reactivate surface with Sika 205

Before applying any other product	If surface seems dusty, greasy or with finger marks, start operation again.
-----------------------------------	---

H3 VEHICLE FRONT STEPS GLUING

1. Remove adhesive tape from underneath step.
2. Apply a thin and even layer of contact adhesive (3M) (684655 or 684654) onto fiberglass and step surfaces. Allow drying for 3 to 5 minutes.
3. Install step beginning with the back and finishing with step nosing. Compress step covering using a roller paying particular attention to corners, edges and front of step.
4. Apply a bead of sealant (684517) around the perimeter of steps. Smooth out the joints.

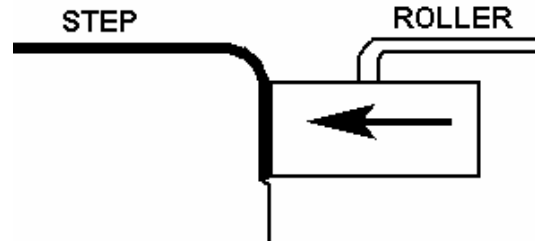

GLUING OF WHITE SAFETY STRIP BETWEEN STEP AND “TARABUS” FLOOR COVERING

1. Sand fiberglass using “Scotchbrite”.
2. Clean using tack cloth.
3. Clean twice using anti-silicone (refer to Section A).
4. Protect surfaces around the step with masking tape.

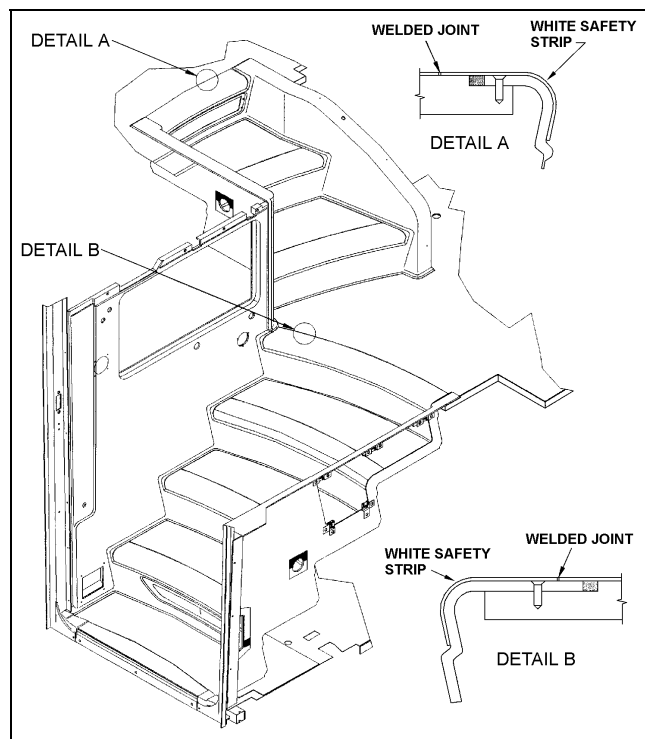

5. Apply contact adhesive (3M) (684655 or 684654) onto both surfaces to glue (fiberglass and back of white safety strip). Drying time: 4 to 5 minutes.

Note: There should be no floor covering adhesive (680028) onto plywood before applying contact adhesive, otherwise the two surfaces won't stick.

6. Position white safety strip with reference to “Tarabus” step covering finishing with step nosing. Compress step covering using a roller paying particular attention to corners, edges and front of step.

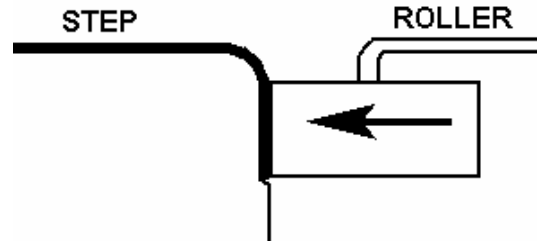

Note: Keep a gap of 1 to 1.5 mm between “Tarabus” covering and white safety strip.

7. Remove masking tape.

11.2 WELDING OF JOINT BETWEEN WHITE SAFETY STRIP AND “TARABUS” FLOOR COVERING

1. Pre-heat welding torch;
 - Set welding torch to position #4.5 (temperature of 500 °C),
 - Heating time: 5 minutes.
2. Before welding, visually ensure that a 1 to 1.5 mm gap exists between white safety strip and “Tarabus” floor covering. Use a knife if this is not the case.

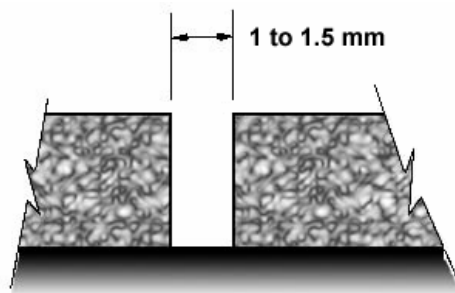

Note: There should be no excess of adhesive on top of surfaces, clean if required using “All-Sol”.

3. Chamfer the joint.

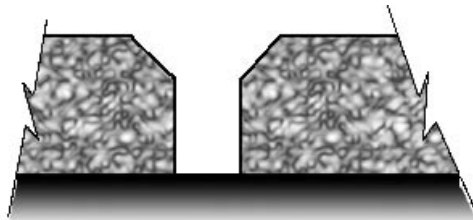

Note: The chamfer width must always be less than the filler bead diameter (between 2.5 and 3 mm).

4. Use chamfer knife. **Be careful not to overcut or to cut to the side to prevent damaging “Tarabus” covering.**

Section 18: BODY



5. Add (about 6 inches) some length to the required length of filler bead to make the joint then cut.
6. Take position with welding torch. The proper position is with a slight slope to the rear.



7. Once the welding torch is ready, insert the filler bead into the nozzle and immediately start welding. Move in a regular manner while pressing slightly with torch.



8. The heel of the fast nozzle must not lean against "Tarabus" covering (always parallel to the surface).



9. Allow cooling down of filler bead (about 5 minutes).

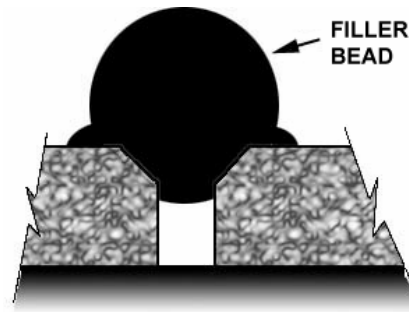

10. Shave filler bead to make it level to the floor. Use supplied knife designed for that purpose.

Note: To facilitate the cut, you can spray some soapy water onto the joint.

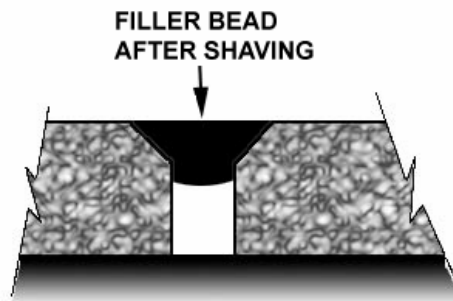

Caution: The procedure for turning the torch off must absolutely be followed. If this step is not taken, the element may burn.

11. Set temperature potentiometer to "0" position. Fan will evacuate residual heat. Leave the torch in operation as it is for 3 minutes.

12. Perform adhesion test using the tip of a flat screwdriver; apply a slight pressure on the joint.

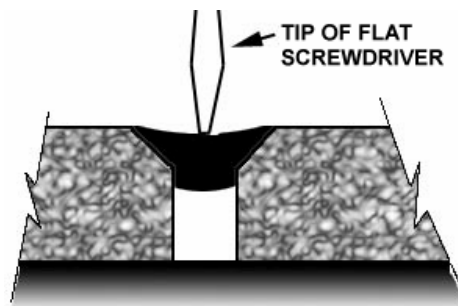

13. If welding was not performed properly, there will a loss of adhesion on one side. If this is the case, repair the joint.

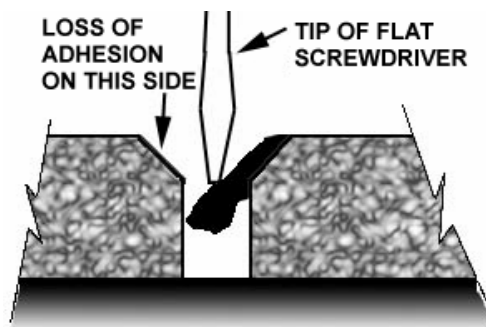

11.3 REPAIR OF A WELDED JOINT

Note: In wintertime, condensation and cold temperature may greatly influenced bonding parameters. Working area must be at a temperature sufficient to prevent reaching condensation point. Mechanically preheat working area (heat lamp or heat gun) or wait until vehicle reaches room temperature.

1. Using a knife, remove portion of joint to be repaired.

Note: Loss of adhesion may be local. If this is the case, repair may also be local.

2. Chamfer the joint again as indicated in paragraph 3, Section: WELDING OF JOINT BETWEEN WHITE SAFETY STRIP AND "TARABUS" FLOOR COVERING.
3. Re-weld the joint as indicated in paragraphs 6, 7 and 8. Use your thumb to hold the filler bead end.

Warning: Nozzle is hot.



4. Always add an extra inch of filler bead at the beginning and at the end of repair.
5. Perform steps indicated in paragraphs 9, 10 and 11.

12. PASSENGER SEATS

H3-41 and H3-45 coaches can be equipped with any of 2 basic seat models and installed in a variety of seating arrangements:

1. The "Tourismo 2" seat is the base model and is available in heights of 40" (102 cm) and 42" (107 cm). Seating arrangement includes 2 card tables which can be folded and removed, and pivoting seats ahead of each card table. Each pair of seats is built on a welded steel frame fastened to the side wall and on a track-mounted pedestal. Standard seating capacity is 48 in H3-41 and 56 in H3-45.
2. The "V.I.P." seat model is an optional seat. "V.I.P." seats are mounted on one row of paired seats built on a common frame on one side of the vehicle, and a row of single seats on the other side of the vehicle with an off-center aisle. Each "V.I.P." seat has its own set of armrests.

Each seat has a easily removable bottom cushion. Upholstery is clipped on the cushion frame for cleaning or replacement. To remove the fabric, simply unclip from the frame. The "Tourismo 2" seats have 3 armrests. The aisle and center armrests can be folded up and down manually, while the window armrest is fixed.

12.1 ROTATING SEATS

1. Remove 1 wing nut holding each seat bottom cushion from under the seat frame.
2. Lift front part of cushions and remove cushions.
3. Remove 4 wing screws fastening seat assembly to seat frame.
4. Pull seat toward aisle and rotate.
5. Align mounting holes and reinstall 4 wing screws.
6. Reinstall seat bottom cushions with wing nuts.

12.2 REMOVING FIXED SEATS

Note: Seats on one row are not interchangeable with seats of the other row.

To remove fixed seats, proceed as follows:

1. Remove 1 nut holding each seat bottom cushion from under the front part of the seat frame.
2. Lift front part of cushions and remove cushions.
3. Remove 4 finishing screws holding plastic cover between side wall and seat frame.
4. Remove 2 cap screws, nuts, and washers holding seat frame to side wall and retain the 2 holding brackets. See figures 27 and 28.

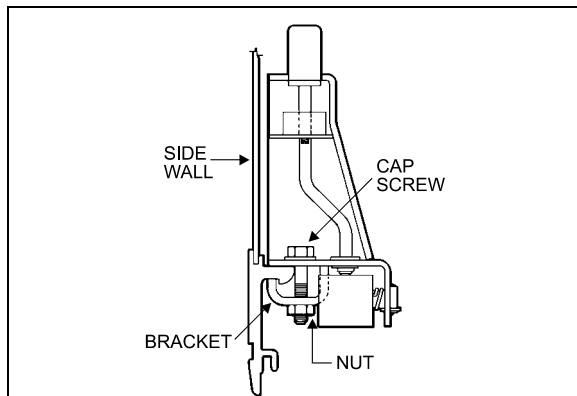

FIGURE 27: ARMREST

18106

5. Remove 2 nuts and washers holding seat frame to pedestal rods.

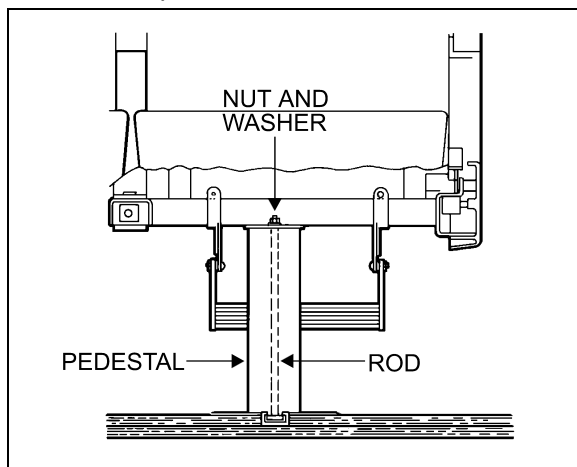

FIGURE 28: SEAT PEDESTAL ASSEMBLY

18107

Note: Bottom end of rod is coated with Loctite and threaded in a steel block which slides in the floor track. Removal of rod is possible if loosened from block. Otherwise, slide rod and block assembly to the front end of track after removing all seats located in front.

6. Remove seat assembly.
7. Reverse the above procedure to install seat assembly.

Note: On newer vehicles, the rod consists of a carriage bolt inserted in a square plate sliding in the floor track. Removal is possible only by the front or rear end of track.

12.3 UPHOLSTERY MAINTENANCE

Coach seats are lightweight, with foam-padded backs and cushions. For both appearance and wearability, best results are obtained if upholstery is cleaned at regular intervals before dirt, dust and grit have been ground into the fabric. Seat fabric is made of 50% wool, 33% cotton, 9% nylon, and 8% acrylic.

12.3.1 Routine Cleaning

All that is required to remove the dirt is a gentle beating with the hand or the back of a brush. This will bring the dirt to the surface where it is easily removed with a vacuum or brush in the direction of the pile which can easily be recognized by running a hand lightly over the pile. If the fabric become excessively dirty, particles of grit will cause gradual wear, reducing the life span of the fabric.

12.3.2 Dry Cleaning

If covers are to be removed for cleaning, dry cleaning is recommended since washing might cause some shrinkage, preventing the covers from being reapplied to the seats without damage. Other than spot cleaning the covers while they are in place, dry cleaning is not recommended, since the resulting fumes could be hazardous in the confines of the coach and the solvent could be detrimental to the foam padding of the seats.

12.3.3 Cleaning With Covers in Place

The most effective and economical method to clean the fabric seat covers is by washing with either an approved foam upholstery cleaner or with a mild household detergent.

Section 18: BODY

Thoroughly vacuum the upholstery. Remove any spots or stains before the seats are washed to avoid a cleaning ring.

Dilute household detergent or liquid foam cleaner according to directions on the container. Pour a small quantity into a flat pan and work into a thick foam with a sponge or brush.

Apply only the foam to the fabric with a sponge or brush. Clean a small area of the fabric at a time with the foam. DO NOT SOAK. Rub vigorously.

Sponge the suds from the fabric with a clean sponge or cloth moistened with water. Rinse the sponge or cloth often and change the water when it becomes dirty.

Allow the upholstery to dry completely before the coach goes back into service. To speed up drying, excess moisture can be blown off the fabric with compressed air.

Caution: Oil in the air line will soil the fabric. Blow the line clear and test air discharge against a plain white piece of paper. It is also effective to press the edge of a flat hardwood stick down on the cushion and slowly draw it across the fabric.

Even very soiled areas can be returned to their original appearance by a thorough cleaning, but a regular schedule of cleaning that keeps the upholstery reasonably clean at all times will greatly enhance the life span of upholstery.

13. COACH SIDE WINDOWS

Seven passenger side windows are provided on each side on H3-41, while the H3-45 have eight. They are made of fixed, single or double-glazed, heat absorbing AS-3 glass. Windows are mounted in painted aluminum extrusions, which hold the glass in place from the top rail of the coach. The extrusion also serves as a hinge to allow the window to swing open when needed. The single-glazed windows are made of tinted tempered safety glass, while the double-glazed windows are made of tinted tempered safety glass outside and clear tempered glass inside.

The two trapezoidal windows are also mounted on an aluminum extrusion (except for H3-45 VIP, where they're mounted with adhesives. Refer to "Adhesive Mounted Windows" in this section, for more information on this type of installation). The trapezoidal windows are made of fixed, double glazed, heat absorbing AS-3

tempered safety glass inside and tempered glass outside.

13.1 EMERGENCY EXIT WINDOWS

Three of the windows on each side serve as emergency exits on the H3-41, while there are three of them on curb side of the H3-45, and four on driver's side. See figures 29 and 30.

Except for the window upper edge, the three other glass edges are unprotected, which causes the workers to be exceptionally careful when manipulating or installing such windows.

In addition, when it becomes necessary to lay down the unprotected edges of the glass window, never use a steel or concrete floor support. It is recommended to use a wooden support, even better, a padded surface.

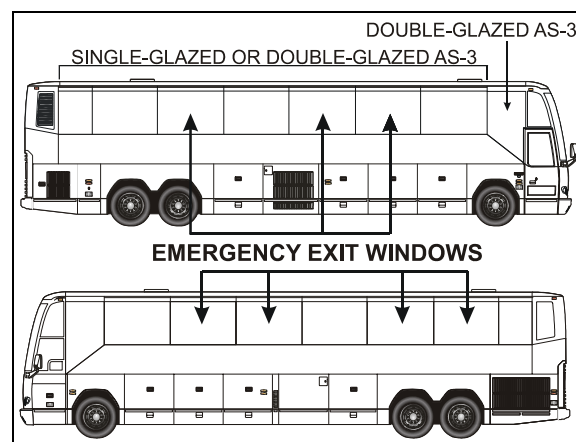

FIGURE 29: H3-45 COACH

18519

An emergency exit window can be opened by pulling the lower part of the release bar to disengage the safety latches, and then by pushing out the window frame (Fig. 31).

Emergency operating instruction decals are affixed under each emergency exit window. To close the window, pull back the window and push down the release bar.

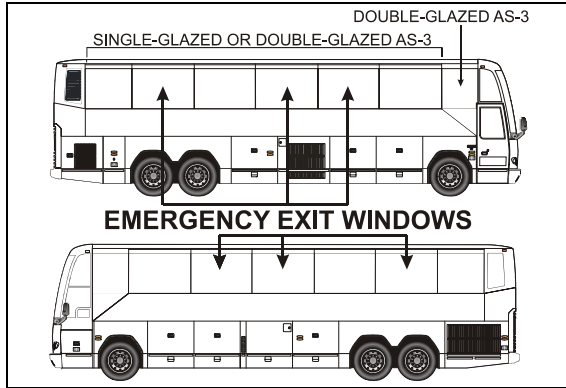

FIGURE 30: H3-41 COACH

18520

13.2 EMERGENCY EXIT RELEASE BAR

The emergency exit release bar system is generally maintenance free.

It has been designed to answer the twenty pound resistance criteria for opening the emergency window. If this handle should be replaced:

1. Remove the screws and bolts securing it to the emergency exit window;
2. To install a new release bar, reverse the procedure.

Note: Check the legal twenty pound maximum resistance to be sure to comply to regulations.

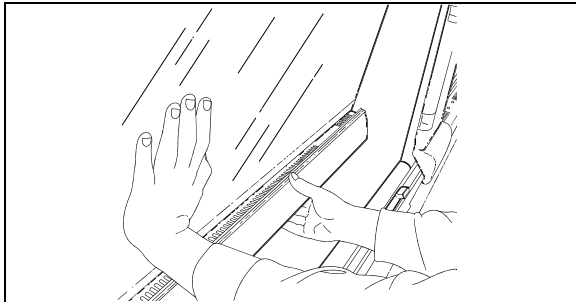

FIGURE 31: EMERGENCY EXIT WINDOW

18391

13.2.1 Emergency Exit Window Adjustment

Emergency exit windows should be checked periodically for easy opening and closing. Pulling the lower part of the release bar with both hands placed near the safety latches should disengage both locks on the window simultaneously. The tension required to release the window should not exceed twenty pounds (9 kg) of force.

The release bar mechanism itself has been designed such as no adjustments are necessary.

If too much effort is required to disengage the locks when pulling the release bar or if the window doesn't close tightly or rattles, check for interference by foreign objects or nearby parts into mechanism, such as the microswitch, rubber seal, wires, etc. Correct situation immediately.

Note: Tangs on the lock must be in a horizontal position.

13.3 FIXED WINDOW REPLACEMENT

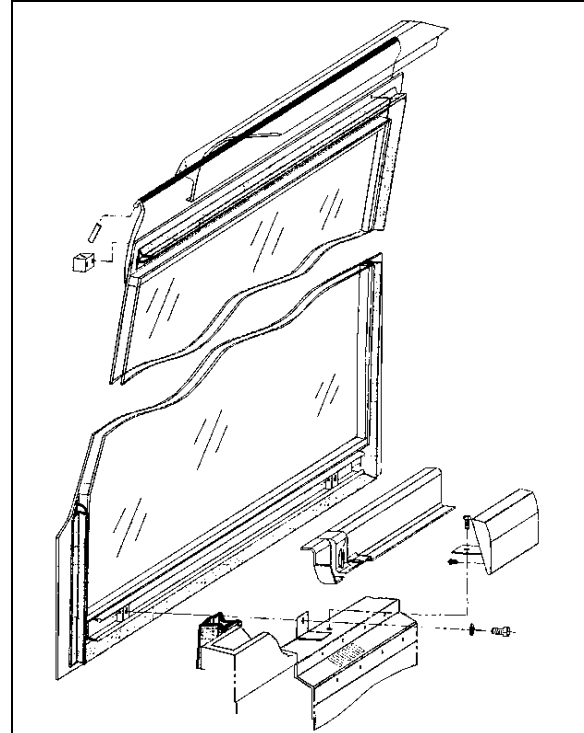

FIGURE 32: FIXED WINDOW

18434

When it becomes necessary to replace the glass of a fixed-type window, follow this procedure:

1. Unscrew the decorative plate and the bottom window bar in order to get access to the window retaining devices.
2. Remove the window bottom retaining bolts.
3. Push the glass window out ninety degrees (90°).

Warning: The window may fall out.

4. The window is free and can be unhooked.
5. Reverse procedure to install a new one.

Note: For all window replacement, it is extremely important to center the top side between the window dividing posts with great precision in order to be able to attach the bottom of window and the structural posts.

13.4 EMERGENCY EXIT WINDOW REPLACEMENT

1. Lift the bar release system and follow the same procedure mentioned above for fixed windows.
2. Remove the stop blocks from the top exterior of the window.
3. Reverse the procedure to install a new emergency exit window.

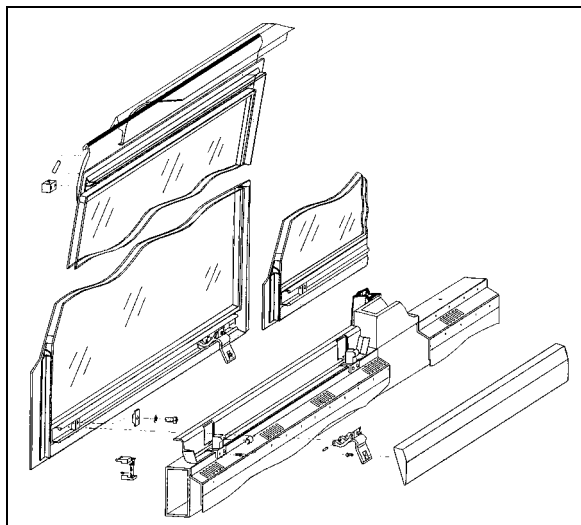

FIGURE 33: EMERGENCY WINDOW 18435

13.5 TRAPEZOIDAL WINDOW REPLACEMENT

Apply procedure for fixed window replacement described in this section but with these variations:

- The angle at which the window will detach is considerably smaller (about 45°);
- These windows are also glued to the structure at certain areas on their perimeter. Note where adhesives are used and apply gluing techniques at these areas to complete replacement of these windows.

13.6 SMALL REAR WINDOWS REPLACEMENT

These small windows are located at the vehicle's rear end, just forward of the lavatory.

Apply procedure for fixed window replacement described in this section but with these variations:

- The angle at which the window will detach is considerably smaller (about 45°);
- These windows are also glued to the structure at certain areas on their perimeter. Note where adhesives are used and apply gluing techniques at these areas to complete replacement of these windows.

Both the trapezoidal windows and the small rear window are fixed in place with adhesives. They are not serviceable, in the event that they may need replacement.

13.7 ADHESIVE-MOUNTED WINDOWS

These windows are located in the vehicle's front and rear caps (Fig. 34).

The adhesive-mounted windows are fixed, double-glazed, heat absorbing AS-2 or AS-3 glass mounted in their opening with polyurethane windshield adhesive. The double-glazed windows are tempered safety glass outside and inside.

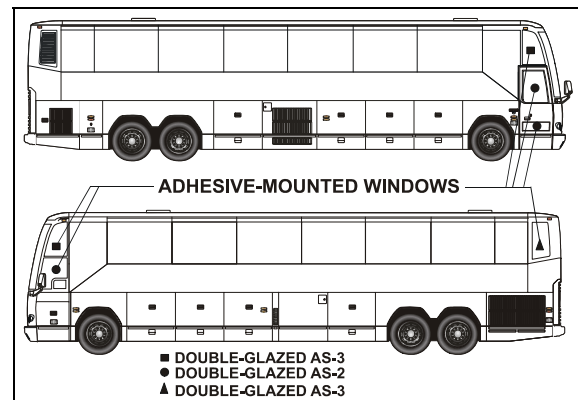

FIGURE 34: ADHESIVE-MOUNTED WINDOWS 18494

13.7.1 Glass Window Replacement

Items Needed:

- Scraper with new blade;
- Masking tape;
- Tremshield tape (Prévost #681089);
- Chix cloths (Prévost #682384);

- Isopropyl alcohol or enamel reducer or NAPA 6383 surface cleaner;
- Sika 205 cleaner;
- Sika 255 F.C. adhesive;
- Disposable vinyl gloves;

Warning: Wear disposable vinyl gloves during this procedure. Do not smoke. Dispose of unused toxic material properly. Heed all warnings on product containers.

1. Remove old window glass and scrape off remaining material up to 1/16" to 1/8" (2 to 3 mm) thick.

Note: Hardened adhesive will not remove easily. A new blade works best to remove all adhesive residue using care not to damage the fiber structure.

2. Place the new window glass in the opening and center it to leave an even gap top and bottom, and from side to side.

Note: Use small shims to raise the glass in proper position. Shims can be cut from the tremshield tape (Fig. 35).

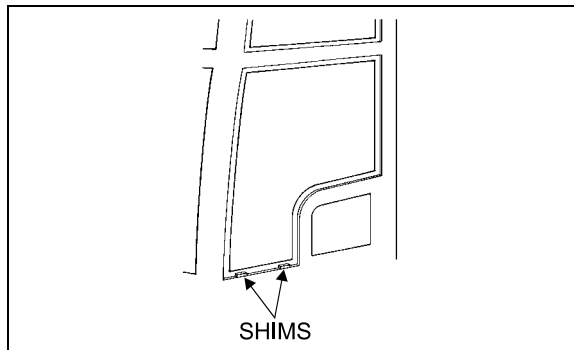

FIGURE 35: ADHESIVE-MOUNTED WINDOW 18079

3. Hold the window glass centered and have an assistant mark the inside contour of the opening on the glass with a china pencil. Remove glass and place it on a table with the pencil mark facing up.
4. Place masking tape on the inside surface of the glass to just cover the china pencil mark, leaving the outer surface exposed for the adhesive. This will make cleanup much easier. For ease of removal, do not overlap the tape at corners.

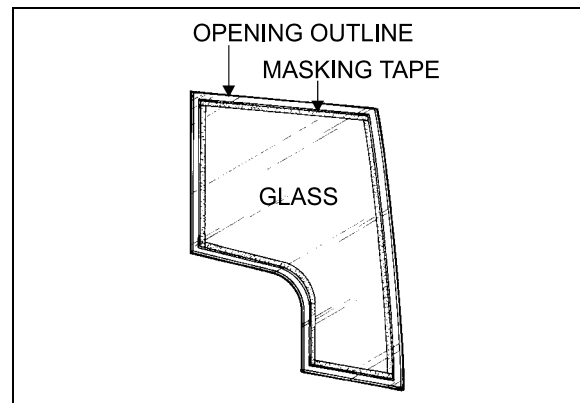

FIGURE 36: ADHESIVE-MOUNTED WINDOW 18080

5. Clean all around the window opening and the window glass edge with Sikaflex 205 (shake well before applying). Let dry 5-6 minutes minimum but no more than 8 hours.

Caution: There must be absolutely no silicone on glass or channel or Sikaflex 255 FC will not stick.

6. Put masking tape on the inner and outer contour of the window opening on the structure, approximately 1/16" (1,5 mm) from the edges of the contour.
7. Install Tremshield tape around the sealing surface of the window opening.

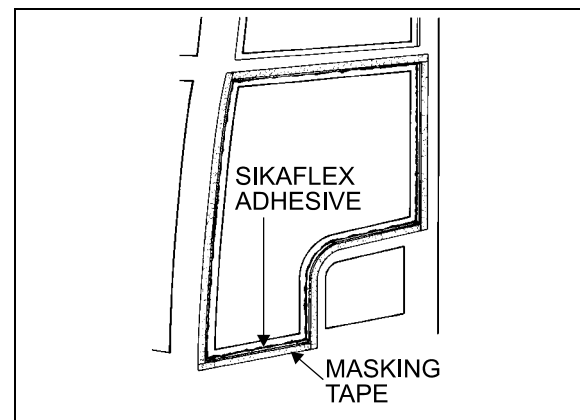

FIGURE 37: ADHESIVE-MOUNTED WINDOW 18081

8. Apply a generous bead of Sikaflex-255 FC polyurethane adhesive on the sealing surface around the window opening from outside the vehicle.

Note: To ease applying of Sikaflex 255 FC, it may be heated to 86° F (30°C).

Note: Bead should touch the side surface of the window opening.

Section 18: BODY

- Place shims correctly, and position window glass in the opening. Press firmly and evenly. Excess adhesive should flow out from behind glass.

Note: Add adhesive in areas where overflow is minimal or if air bubbles are present.

- Smooth the adhesive joint using your finger (wear vinyl gloves). Remove excess material around both sides of the window as soon as possible before adhesive dries.

Note: Remove most of the adhesive from the scraper or trowel with a rag, and then dip tool in heavy hydrotreated naphtha (vanishing oil) after each use for cleaning.

Caution: Never use solvents to clean excess adhesive.

- Remove masking tape at once, clamp window glass suitably and let dry overnight or at least 8 hours.
- Spraying pure water on the joint will accelerate the drying process.

14. WINDSHIELD

The windshield is single-glazed AS-1 laminated safety glass. Each windshield side is laced to a flange around an opening in the front structure by means of a one-piece black rubber extrusion and locked with two filler strips. Proper installation of the windshield is necessary to ensure watertightness. Since glass varies in fit depending on the supplier, we recommend installing a replacement windshield obtained from Prévost Parts to ensure proper fit. Windshields obtained from other sources should be checked for proper size and curvature.

Note: For more information on windshield removal or installation, a video is available from Prévost Parts Inc..

14.1 REMOVAL

Warning: Windshield removal and installation must be performed by more than one person. To avoid personal injury, wear protective gloves when handling the windshield glass.

- Remove the wiper arms of the affected windshield.
- To ease damaged windshield removal, remove the two top rubber filler strips from the rubber extrusion, then the two rubber

filler strips on each side. Finally, remove the rubber filler strip located on top of rubber extrusion bottom section. Leave the bottom filler strip in place.

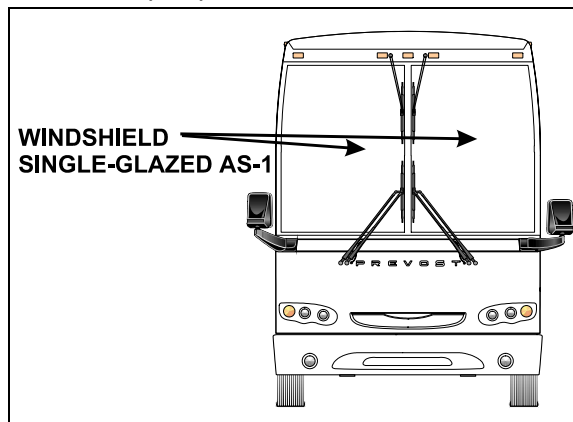

FIGURE 38: WINDSHIELD

18495

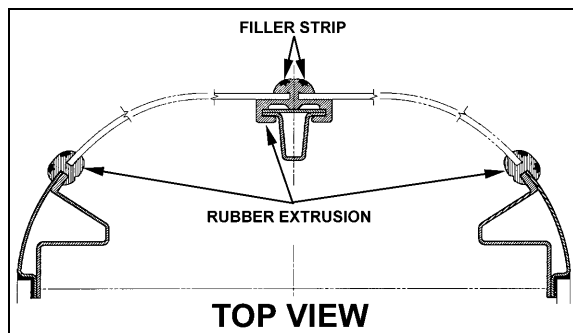

FIGURE 39: WINDSHIELD INSTALLATION TOP VIEW

18098

- From inside of vehicle, push against the top L.H. side corner of windshield for the removal of a R.H. side windshield. If the L.H. side windshield had to be removed, you would have to push against the top R.H. side corner.

Note: We are referring to the L.H. and R.H. side as viewed from the inside of the vehicle.

- At the same time, another person gradually lifts the rubber lip from the vehicle exterior using a plastic spatula from top to bottom.
- Remove the entire damaged windshield and broken glass if applicable.
- Clean the rubber extrusion channel with Sika 205. Refer to heading "Windshield Installation Only" in this section for instructions on how to reinstall windshield.

Note: If the rubber extrusion is damaged, remove and discard it, then clean the windshield opening with Sika 205. Refer to heading "Installation of Rubber Extrusion and Windshield" in this section for complete instructions.

14.2 WINDSHIELD INSTALLATION ONLY

1. Spray rubber extrusion with soapy water to ease windshield insertion.
2. Insert rope into rubber extrusion leaving enough length at each corner to make a loop. Spray soapy water onto rope and rubber extrusion (Fig. 40).
3. Slide windshield into rubber extrusion groove starting with the bottom curved side edge. Using a plastic spatula, move the rubber extrusion lip aside to gradually insert the windshield into the groove.

Note: Spray lubricant on a regular basis to ease windshield insertion.

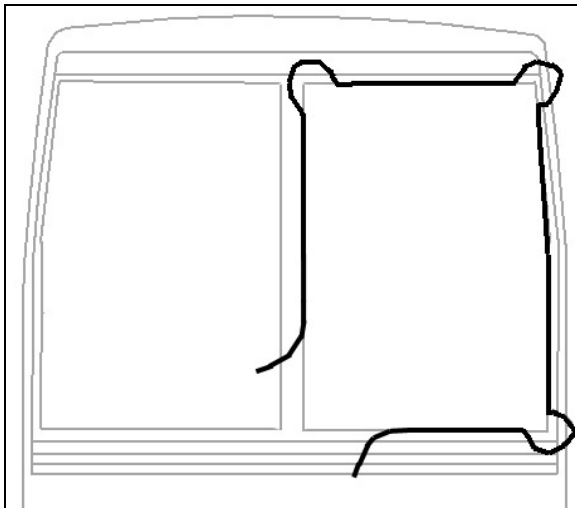

FIGURE 40: WINDSHIELD INSTALLATION USING ROPE

4. Using the same type of plastic spatula, repeat the same operation from inside of vehicle, gradually inserting the windshield into the groove.

Note: Make sure windshield bottom edge is well inserted into the rubber extrusion groove before proceeding with the sides.

5. Then, working from both sides of windshield bottom to top, gradually move the rubber extrusion lip aside to insert the windshield into the groove. Use also lubricant on the inside of vehicle to insert the windshield into the rubber extrusion groove.

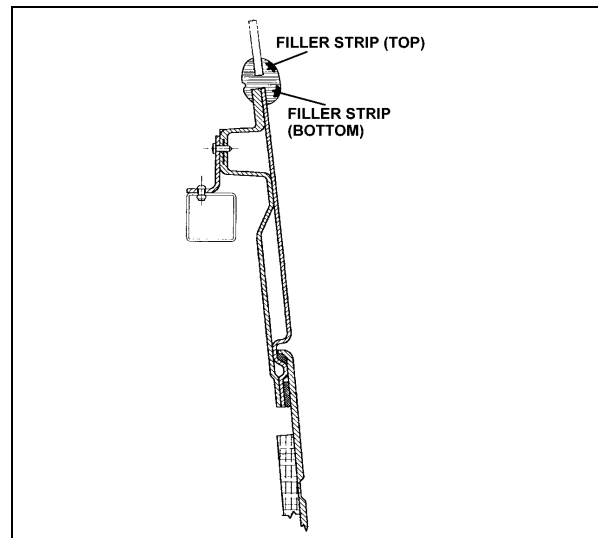

FIGURE 41: WINDSHIELD INSTALLATION SIDE VIEW 8099

6. Insert the top curved corner then finish with the top of windshield.
7. At the top of windshield, clean surface between fiberglass and rubber extrusion using Sika 205 (Fig. 42).

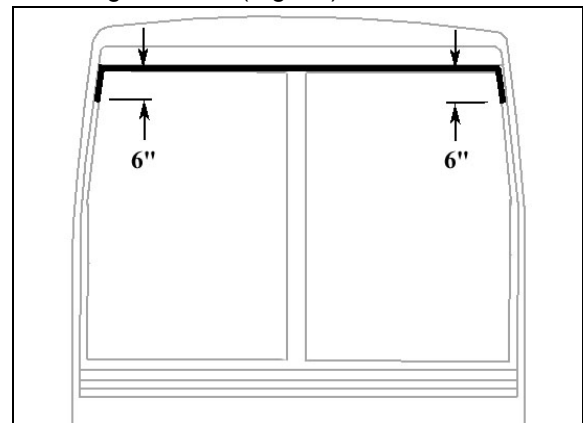

FIGURE 42: APPLICATION OF SIKA 221 BLACK

8. Apply Sika 221 black between fiberglass and rubber extrusion.
9. Spray filler strip and rubber extrusion groove generously with lubricant.

Note: Filler strips retract with time. Install ends of filler strips as tight as possible in the V-channel.

10. Using the special filler insertion tool, insert the filler into the bottom rubber extrusion groove. Gradually insert filler ensuring to leave a 2 inch excess length at the filler extremity.

Section 18: BODY

11. Every 6 inches or so, it is important to compress the filler due to its tendency to contract during drying process.
12. When filler insertion is almost complete, cut filler at a 45° angle leaving ¼" of excess length to thwart filler contraction over time then insert filler into groove.
13. Continue with side filler strips and finish with top ones.
14. Reinstall windshield wiper and destination sign if applicable.

14.3 INSTALLATION OF RUBBER EXTRUSION AND WINDSHIELD

Caution: The black rubber extrusion securing the windshield in the opening fits correctly in only one position. Find the correct position of the rubber extrusion now, and make reference marks with a china marker to avoid searching for the correct position later in the procedure.

1. Clean the windshield opening sealing surfaces with Sika 205 and let dry 1 to 2 minutes.

2. Clean the rubber extrusion with wiping towels soaked with Sika 205 and let dry 1 to 2 minutes.

Note: Force the soaked towels in the channels for good cleaning in these critical areas.

3. Find the reference marks made earlier and install the rubber extrusion in the windshield opening.
4. Install windshield as per paragraph 10.2: "Windshield Installation Only".

15. BODY PANELS AND DOORS

Each of the doors should be checked for proper operation. This includes latching. Also, inspect each of the doors for damage, missing, or loose parts. Repair or replace those parts as needed.

Unless otherwise noted, body panels and doors should be aligned and centered with surrounding panels. In general, a gap of ¼ inch (6 mm) is desirable between panels. Refer to figure 41 for specified gaps.

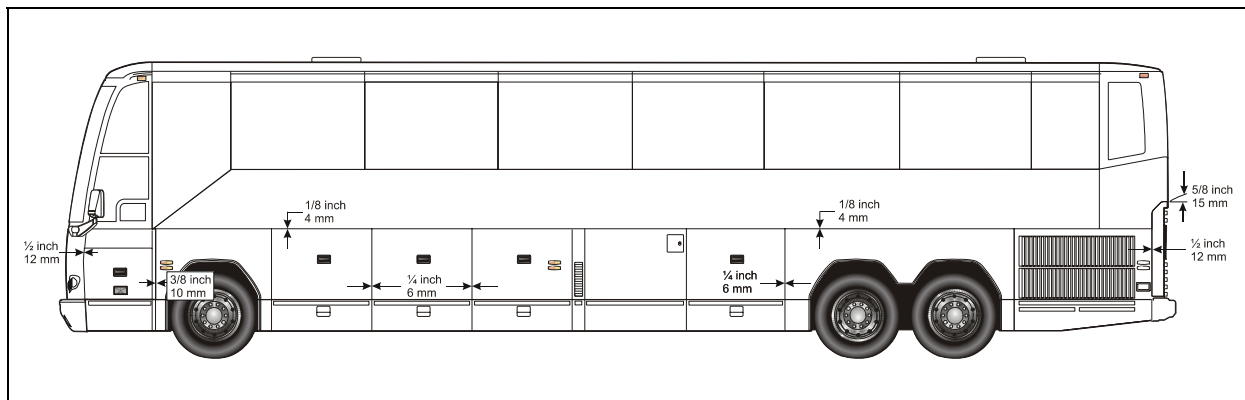

FIGURE 43: BODY PANEL SPACING

18496

16. BAGGAGE COMPARTMENT DOORS

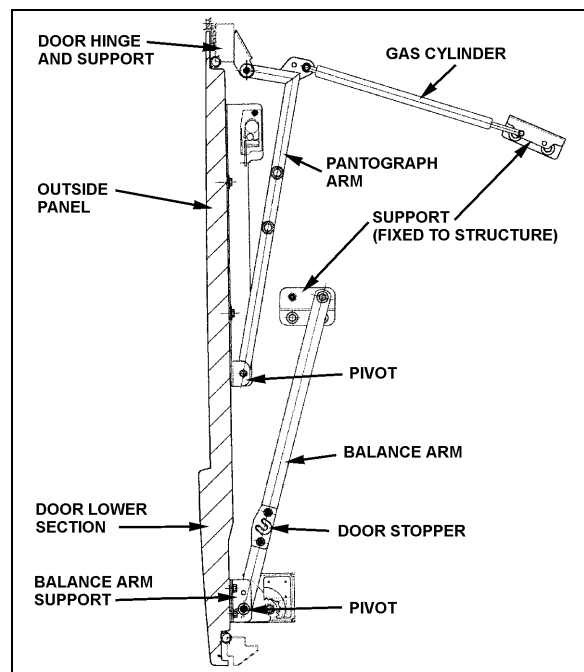

FIGURE 44: BAGGAGE COMPARTMENT DOOR 18061

There are 6 pantograph doors serving as baggage compartment doors on the H3-41, while there are 8 on the H3-45 and the V.I.P (depending on options, VIP model may have even more pantograph doors). Each of these doors is of identical design. A centrally mounted, key-lockable door handle unlatches the door which can then be pulled out and raised up in a path parallel to the side of the vehicle. The door is held in open position by two fully extended gas-charged cylinders, giving clear access to the opening of the baggage compartment.

From its fully open position, the door can be closed by pulling down on the door panel, and letting go when you sense the door will close on it's own. The door will easily hinge its way back in the contour of the compartment opening and will be held closed by two latches. Each door can be opened by lifting the centrally mounted handle to unlatch the door and lifting it all the way up. If the door does not remain in the fully open position, one or both cylinders on that door is (are) defective. To test the cylinders, first support the door in the fully open position with proper equipment. Disconnect the rod end of one cylinder and try to retract the rod. If strong resistance is felt, the cylinder is in good condition and can be reinstalled. If the rod

retracts with little effort, the cylinder is defective and should be replaced at once (Prévost #980024). Test the other cylinder on that door the same way.

Note: In case of malfunctioning or in specific situations, use door stoppers to secure the door in the open position.

16.1 PANTOGRAPH ADJUSTMENT

Warning: Park vehicle safely, apply parking brake, stop engine and set batteries master switches to the "OFF" position prior to working on the vehicle.

Note: Refer, if needed, to figure 44 for identification of door components.

If the door bends when opening or if pantograph does not function properly, it is probably because the pantograph arms are misadjusted.

The pantograph arms should measure the same length. Measure distance between a pantograph arm end and a straight edge resting on structure. Repeat procedure for the other arm. The distance on each side should be equal. If not, bend appropriate arm until desired measure is obtained. (Fig. 46 and 47). Doors can be adjusted by bending the arms as follows:

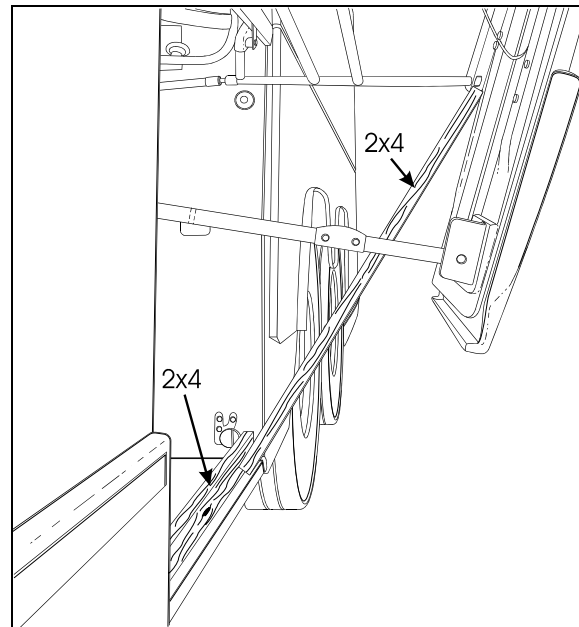

FIGURE 45: PANTOGRAPH ADJUSTMENT 18319

1. Open the door halfway up.
2. Install a piece of wood (a 2x4 will do) along the bottom of the baggage compartment.

Section 18: BODY

Arrange so it rests against the striker pins and is prevented from sliding further in the compartment.

3. Install another piece of 2x4 between the first piece and the bottom of the pivot of the lowest (or shortest) pantograph arm, (Fig. 45).
4. Pull down on the opposite side of the door to bend the door around the pantograph arm pivot (prevented from moving by the 2x4).
5. When the door is straight, remove the 2x4's and check door operation and fit. A difference of $3/32$ " (2mm) between both sides is accepted (Fig. 47).
6. Repeat as necessary.

When the pantograph is correctly adjusted, the distance between the vertical steel member and the lateral edge of the door should be $1-3/8$ " (35mm).

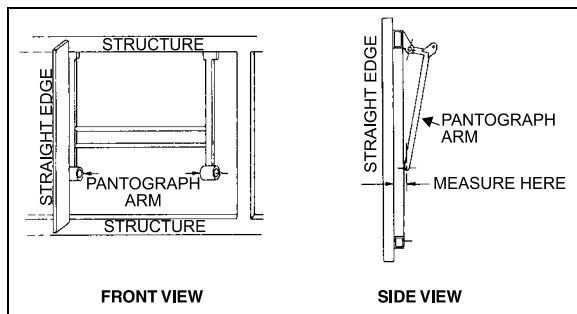

FIGURE 46: PANTOGRAPH DOOR ADJUSTMENT 18062

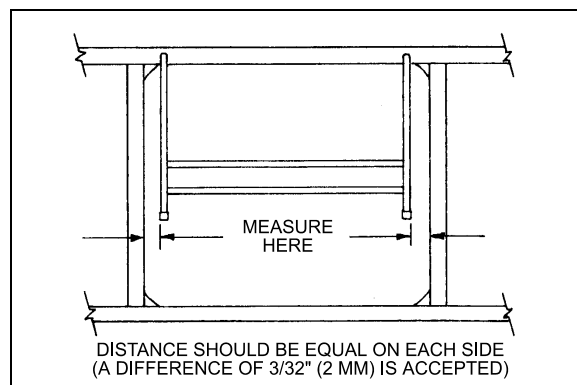

FIGURE 47: PANTOGRAPH DOOR ADJUSTMENT 18063

16.2 DOOR ADJUSTMENT

If the door is misaligned at front or rear posts, at top, or at bottom adjust as follows:

1. Unscrew and remove both striker pins. Loosen bolts retaining door to pantograph and balance arm supports. With door

closed, adjust height so the top of the door fits flush with the adjacent doors. Then, complete tightening the four bolts retaining door to each pantograph arm support. A gap of $1/8$ " (3mm) between the top of the door and the stainless steel support is given as a guide (Fig. 48).

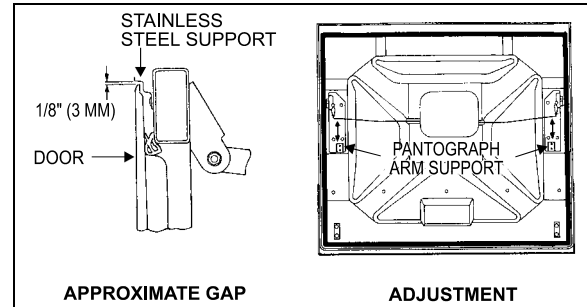

FIGURE 48: BAGGAGE COMPARTMENT DOOR 18064

2. Slightly open the door, position it to obtain a gap of 4" (100mm) between structure and door panel upper lip, maintain door in this position while an assistant completes tightening the two bolts retaining door to each balance arm support (Fig. 49).

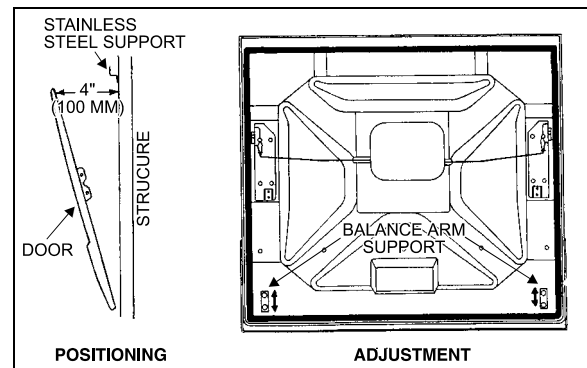

FIGURE 49: BAGGAGE COMPARTMENT DOOR 18065

3. Fully open the door, loosen the two bolts retaining each gas cylinder support to structure, position door parallel with adjacent doors and complete tightening bolts. A measure of $6" \pm 1/4$ " (150mm \pm 7mm) between door panel lip (at level of upper edge of lower section) and the lateral panel is given as a guide.

Caution: For converted vehicles provided with "Awning" windows, fully open window then adjust door opening angle so the door does not interfere with window.

4. With door slightly open, pull door handle while an assistant checks that both latches release simultaneously. If not, with latch

engaged, gently bend the appropriate latch control rod until proper timing is achieved (Fig. 50).

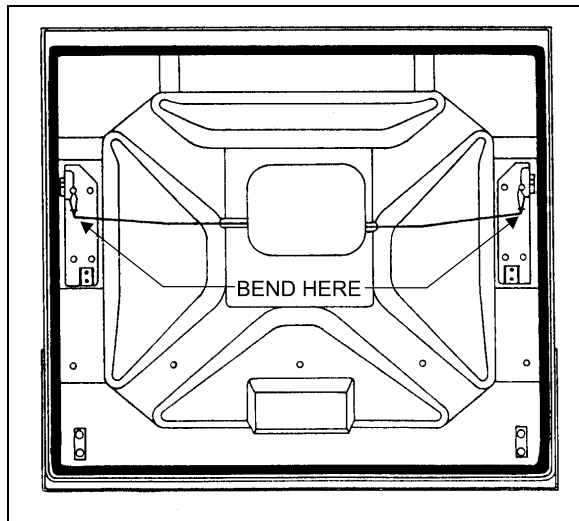

FIGURE 50: BAGGAGE COMPARTMENT DOOR 18067

5. Install both striker pins, bring the door close to them, and adjust the height of pins so they are well centered with latches (Fig. 51).

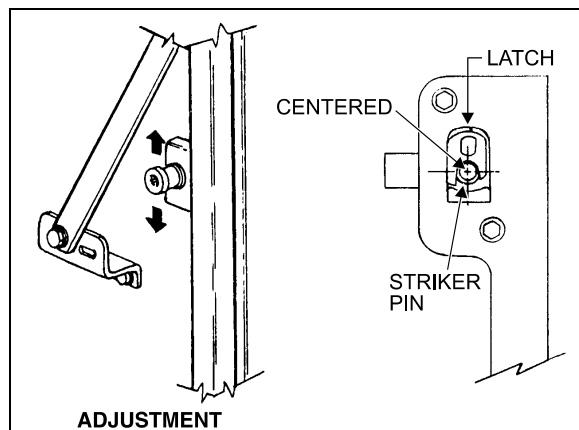

FIGURE 51: BAGGAGE COMPARTMENT DOOR 18068

Note: Before proceeding with the following step, mark the position of striker pins on structure to avoid upsetting the vertical adjustment of the pin.

6. Loosen the striker pins just enough to allow them to be moved with a hammer. Working from inside compartment and with the door closed (lower catches engaged), hit the pin washers to horizontally move the pins and consequently the door, while an outside assistant checks the fit. A gap of $1/16'' + 3/64''$, $-1/64''$ (1,5mm +1mm, -0,5mm) between the stainless steel support for the

lateral panel and the door panel lip is recommended (Fig. 52)

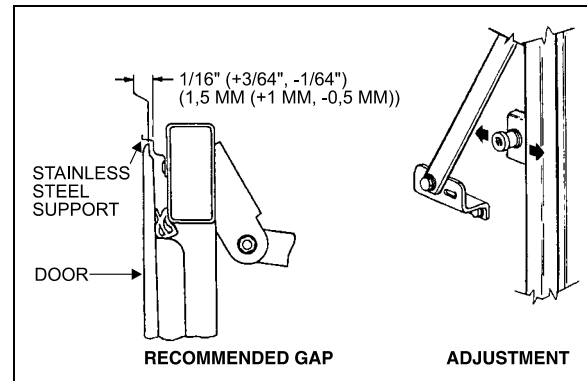

FIGURE 52: BAGGAGE COMPARTMENT DOOR 18069

7. With door shut, it should have a gap of $3/8'' \pm 5/64''$ (10mm \pm 2mm) between door panel lip (at level of upper edge of lower section) and structural post. If not, move pins horizontally until correct gap is obtained. Fully tighten the pins after adjustment is achieved (Fig. 53).

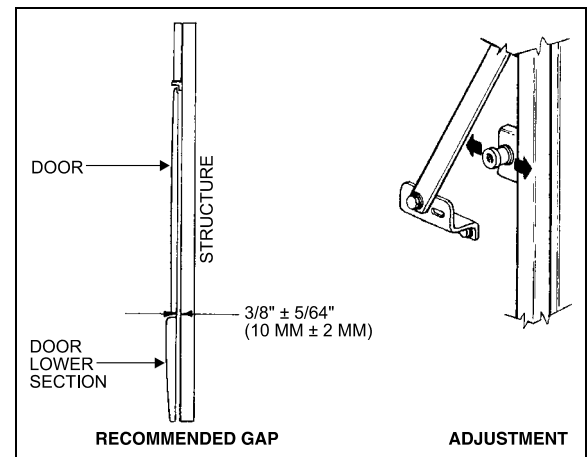

FIGURE 53: BAGGAGE COMPARTMENT DOOR 18070

8. Recheck gap mentioned in step 6. If gap has changed, correct by adjusting arm support to structure. Loosen the bolt supporting the balance arm on door lower section and close the door, gap adjustment will automatically result. Tighten the bolt from inside the compartment (Fig. 54).

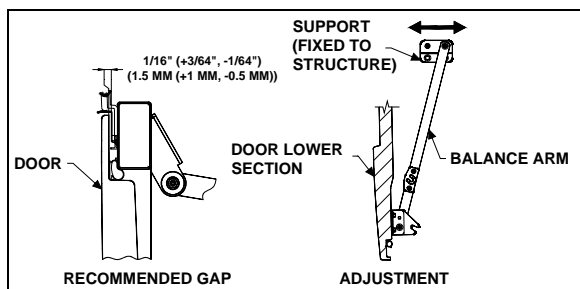

FIGURE 54: BAGGAGE COMPARTMENT DOOR 18071

Once the adjustment procedure is achieved, ensure that all bolts are securely tightened.

17. DOOR HANDLES

Compartment door handles are non serviceable. When a door handle has to be removed, proceed as follows:

1. Unscrew the four (4) retaining screws;
2. Remove the two (2) wires connecting the handle to the door latch locking mechanisms.
3. To install a new handle, reverse the procedure.

18. ENGINE COMPARTMENT DOOR

The engine compartment rear door (Fig. 55) rises in the same way as the baggage compartment doors and is held open by three gas-charged cylinders (Prevost # 980024). The engine compartment opens by lifting a handle accessed from the R.H. side of the engine compartment.

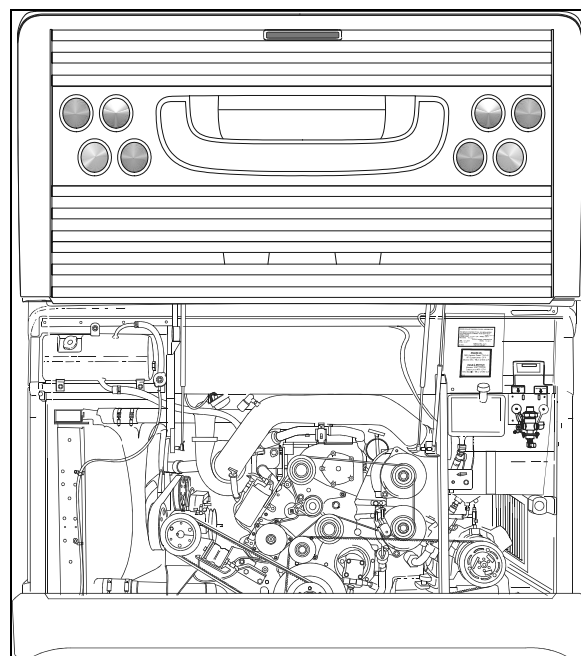

FIGURE 55: ENGINE COMPARTMENT DOOR 18497

When pushed up, the handle pulls on two steel wires, each steel wire connected to its respective door latch locking the rear door. Both steel wires are looped at the release handle and can be adjusted to proper length to ensure positive release of both catches when the handle is raised.

18.1 ENGINE DOOR ADJUSTMENT

As indicated above, the engine door mechanism is similar to the baggage door mechanism using a pantograph and 3 gas cylinders to move the door up and down.

For a minor horizontal or vertical adjustment:

1. Open the door mid-height;
2. With the help of an assistant, pull down one side of door while holding up the other side to bend the pantograph arms in the desired position;
3. Close the door and check the top edge parallelism between the door and the vehicle end cap structure. The space may be somewhere between 10 and 15 mm;
4. Repeat until satisfied.

18.2 MINOR TOP EDGE DEPTH ADJUSTMENT

Two rubber spring loaded stops may be adjusted. They are located near the top edge on each side of the rear door.

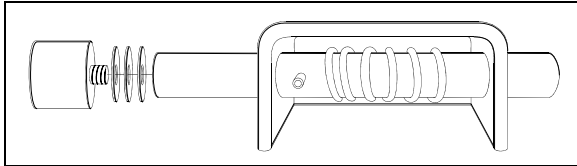

FIGURE 56: DOOR STOP

18324

To adjust:

1. Open door.
2. Unscrew rubber stop.
3. Add or remove washers as needed.
4. Firmly screw back rubber stop.

18.3 MINOR LOWER EDGE DEPTH ADJUSTMENT:

1. Open door.
2. Slightly loosen the striker pins on each side of door.
3. Using a hammer, strike striker pin gently in the desired direction (in or out).
4. Close the door slowly and check fit.
5. Repeat 3 and 4 to adjust the other striker pin.
6. When door depth is completed on the four corners, both vertical door sides should be parallel to the vehicle body structure.
7. Firmly tighten the striker pins (2) to lock them in position.

19. ENGINE AIR INTAKE GRILL

When needed, the engine air intake grill can be changed:

1. Cut the seal around the grill with a sharp edged knife.
2. Remove the grill from the vehicle.
3. On the vehicle grill opening, using the knife, remove as much adhesive as possible.
4. Sand the new grill backing edge to remove the glossy surface.
5. Clean with alcohol, wipe dry.

6. Apply SIKA 205 primer to the grill opening and the grill edges. Allow to dry at least 2 minutes for chemical evaporation.
7. Apply SIKA 255 FC adhesive on the grill edge.
8. Install the grill on the vehicle, adjust and fasten with masking tape. Allow 8 hours setting period.

20. RADIATOR DOOR ADJUSTMENT

Radiator door may be adjusted for proper fit by untightening hinge nuts:

1. Loosen the nuts (1, Fig. 57) holding the hinge to the vehicle structure to shift the door "IN or OUT" and "UP or DOWN".
2. Loosening nuts (2, Fig. 57) allows the door to be shifted "LEFT or RIGHT" and "UP or DOWN".
3. Adjust the door position depending on the gap needed between exterior finishing panels (Fig. 43).
4. Tighten the nuts.
5. Check that the door swings freely and closes properly. It may be necessary to adjust the door latch to get proper fit and operation.

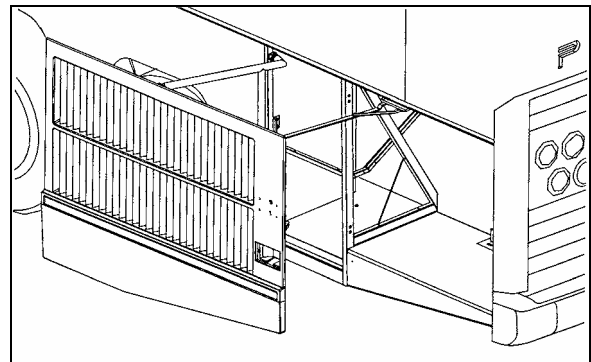

FIGURE 57: RADIATOR DOOR

18XXX

To adjust the latch mechanism and the striker pin:

1. Open the door to access the striker pin.
2. Slightly loosen the striker pin.
3. Using a hammer, adjust the striker pin to center it in the door latch mechanism.
4. Tighten the striker pin.
5. Check door fit and operation.

21. CONDENSER DOOR ADJUSTMENT

1. Open the condenser door.
2. Loosen the nuts (1, Fig. 58) holding the hinge (3, Fig. 58) to hinge attachment (4, Fig. 58). Loosening nuts (1, Fig. 58) allows the condenser assembly to be shifted "LEFT or RIGHT" and "UP or DOWN".
3. Adjust condenser assembly position at the hinge.
4. Tighten the nuts.
5. Loosen bracket nuts holding the panel to condenser. Panel (6, Fig. 58) may be shifted

"IN or OUT", "LEFT or RIGHT" and "UP or DOWN".

6. Adjust condenser panel at brackets (2, Fig. 58) and (5, Fig. 58).
7. Tighten the nuts.
8. Respect the required gap between exterior finishing panels (Fig. 43).
9. Check that the door swings freely and closes properly. It may be necessary to adjust the door latch to get proper fit and operation.

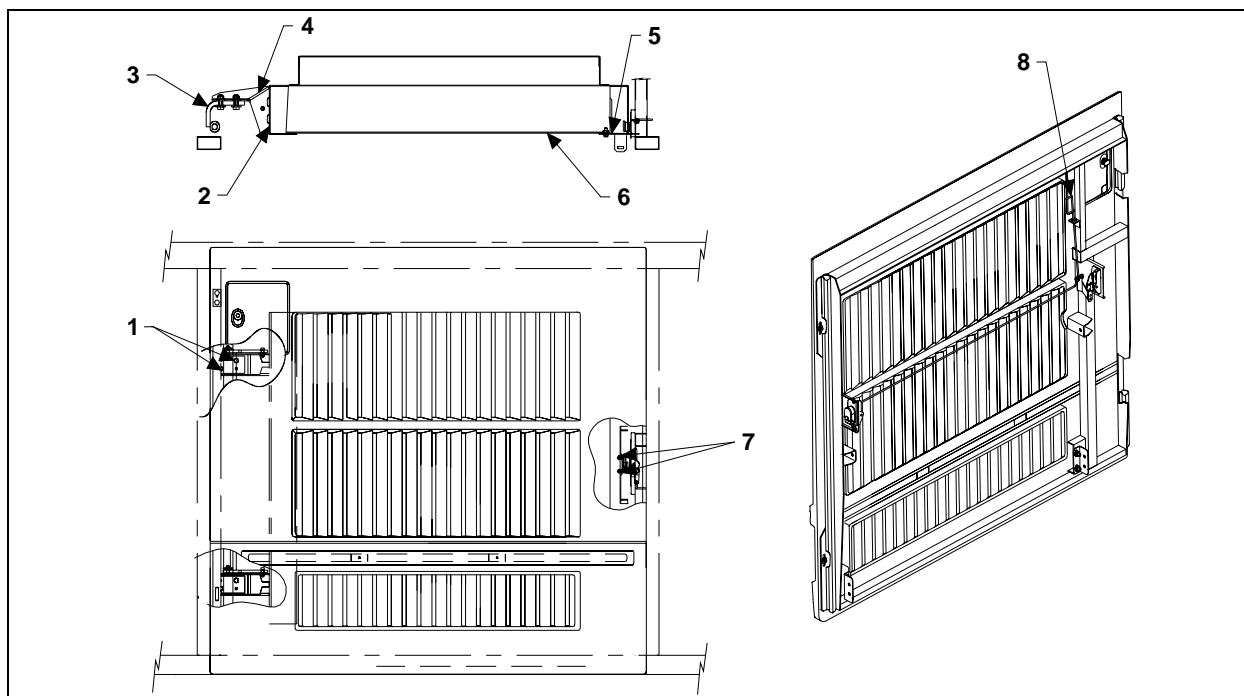

FIGURE 58: CONDENSER DOOR

D280201

22. FUEL FILLER DOOR

1. Open the fuel filler door (1, Fig. 59).
2. Loosen the screws (3, Fig. 59) holding the panel to hinge (2, Fig. 59) assembly.
3. Adjust the fuel filler door position according to distance required between exterior finishing parts (Fig. 43).
4. Tighten the nuts.
5. Check that the door swings freely and closes properly.

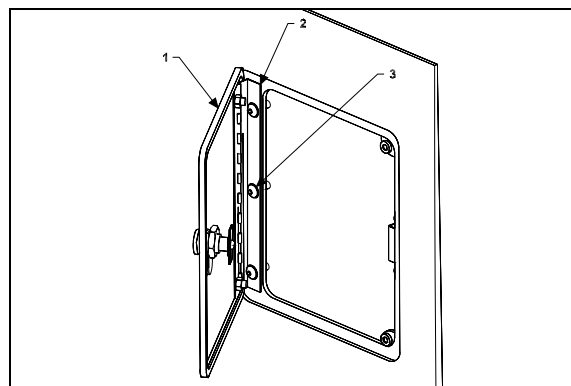

FIGURE 59: FUEL FILLER DOOR

1875003D

23. FRONT SERVICE COMPARTMENT

Adjustment of the front service compartment door can be done by following these steps:

1. Open the door.
2. Loosen nut (2, Fig. 60).
3. Move part (1, Fig. 60), as close as possible to exterior of coach, so as to have enough clearance for proper door opening.
4. Tighten nut (2, Fig. 60).
5. Loosen nut (3, Fig. 60). Hinge allows the door to be shifted "IN or OUT".
6. Adjust door panel to have the same gap space as neighboring panels or refer to figure 43 for specified gap space. Only if necessary, use the adjustment allowed by moving part 1, Fig. 60.
7. Loosen screws (5, Fig. 61) to allow the door to be shifted "UP or DOWN".
8. Adjust the door position.
9. Tighten the screws.
10. Check that the door swings freely and closes properly. It may be necessary to adjust the door latch to get proper fit and operation.

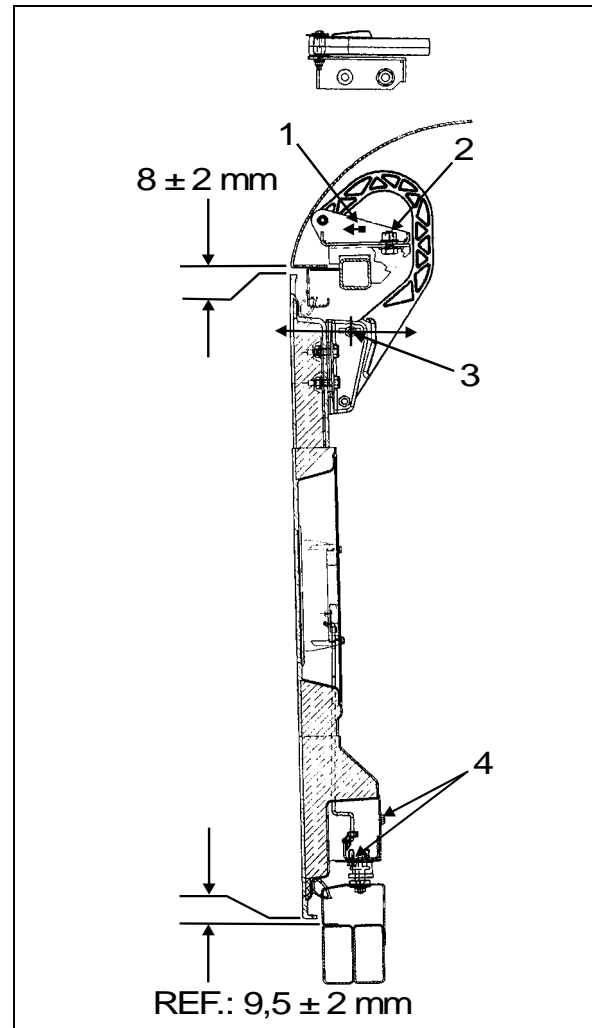

FIGURE 60: DOOR HINGE

18194

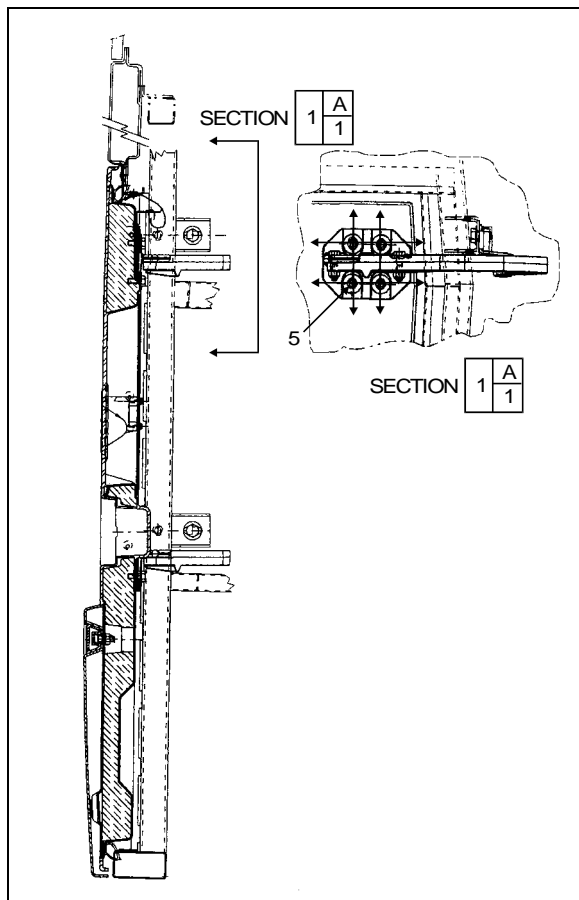

FIGURE 61: FRONT SERVICE DOOR 18195

23.1 LATCH MECHANISM ADJUSTMENT

To adjust the latch mechanism and the striker pin, open the door to access the striker pin. Slightly loosen the striker pin. Using a hammer, adjust the striker pin to center it in the door latch mechanism. Tighten the striker pin. Check door fit and operation.

24. ENGINE COMPARTMENT R.H. SIDE DOOR

The engine compartment R.H side door can be adjusted by following these steps:

1. Open the door.
2. Loosen nut (1, Fig. 62).
3. Move part (3, Fig. 62) as shown in figure for "LEFT or RIGHT" adjustment.
4. Tighten nut (1, Fig. 62).
5. Loosen nut (2, Fig. 62).

6. Hinge allows the door to be shifted "IN or OUT".
7. Adjust the door in accordance with the required distance between exterior finishing parts (Fig. 43).
8. Loosen screws (4, Fig. 62).
9. Screws allow the door to be shifted "UP or DOWN".
10. Adjust the door position according to the distance required between exterior finishing parts (Fig. 43).
11. Tighten the screws.

Check that the door swings freely and closes properly. It may be necessary to adjust the door latch to get proper fit and operation.

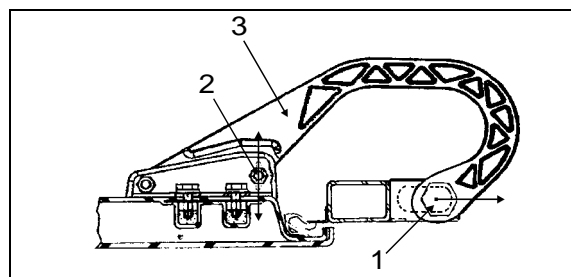

FIGURE 62: DOOR HINGE 18196

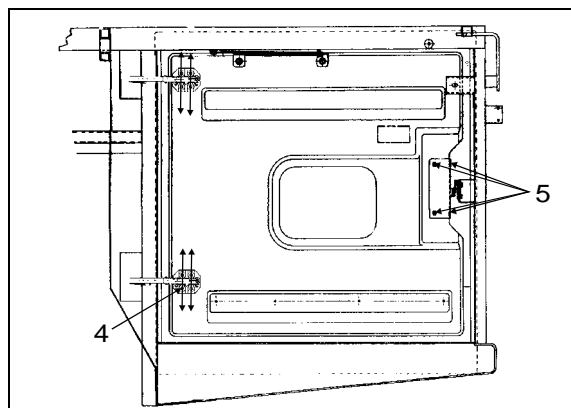

FIGURE 63: ENGINE COMPARTMENT R.H. DOOR 18197

24.1 LATCH MECHANISM ADJUSTMENT

To adjust the latch mechanism and the striker pin, open the door to access the striker pin. Slightly loosen the striker pin. Using a hammer, adjust the striker pin to center it in the door latch mechanism. Tighten the striker pin. Check door fit and operation.

25. EVAPORATOR DOOR ADJUSTMENT

1. Open the door.

2. Loosen nut (1, Fig. 64).
3. Move part as shown in figure for "LEFT or RIGHT" adjustment.
4. Tighten nut (1, Fig. 64).
5. Loosen nut (2, Fig. 64). Hinge allows the door to be shifted "IN or OUT".
6. Adjust the door in accordance with the required distance between exterior finishing parts (Fig. 43).
7. Loosen screws (3, Fig. 64). Screws allow the door to be shifted "UP or DOWN".
8. Adjust the door position according to the distance required between exterior finishing parts (Fig. 43).

9. Tighten the screws.

Check that the door swings freely and closes properly. It may be necessary to adjust the door latch to get proper fit and operation.

25.1 LATCH MECHANISM ADJUSTMENT

1. To adjust the latch mechanism and the striker pin:
2. Open the door to access the striker pin.
3. Loosen slightly the striker pin.
4. Using a hammer, adjust the striker pin to center it in the door latch mechanism.
5. Tighten the striker pin. Check door fit and operation.

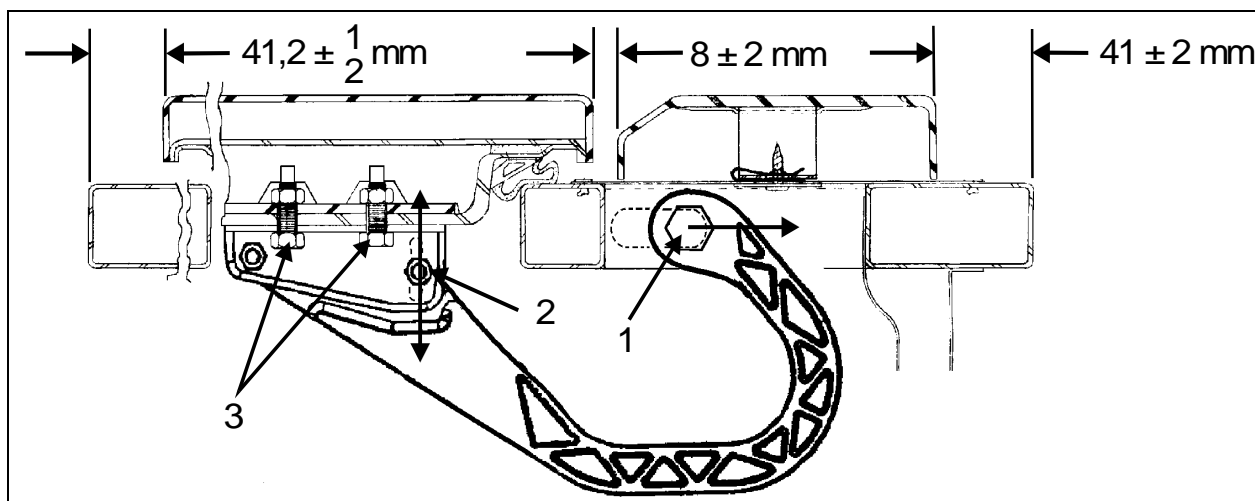

FIGURE 64: EVAPORATOR DOOR

18198

26. MAIN POWER COMPARTMENT

To adjust the main power compartment door:

1. Loosen nut (1, Fig. 65).
2. Move part as shown in figure for "LEFT or RIGHT" adjustment.

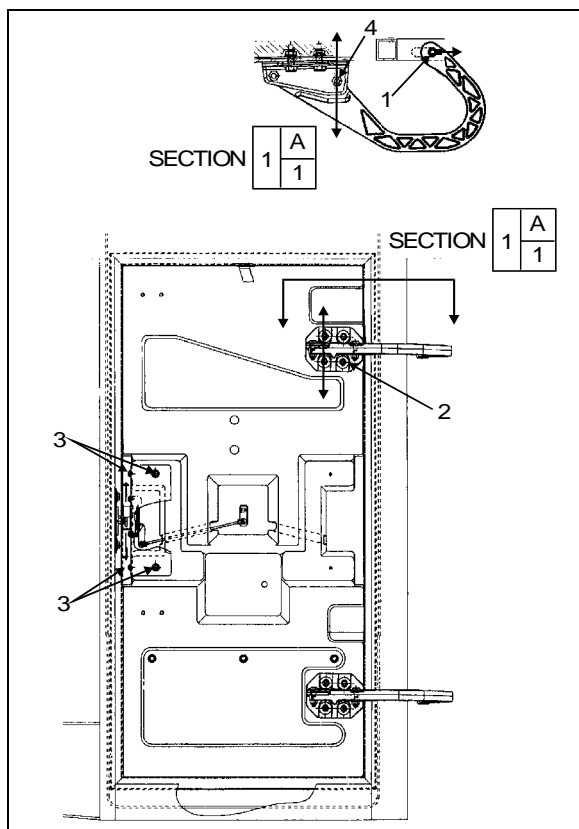

FIGURE 65: MAIN POWER COMP. DOOR 18199

3. Tighten nut (1, Fig. 65).
4. Loosen nut (4, Fig. 65).
5. Hinge allows the door to be shifted "IN or OUT".
6. Adjust door panel to have the same gap space as neighboring panels or refer to figure 43 for specified gap space
7. Loosen screws (2, Fig. 65). Screws allow the door to be shifted "UP or DOWN".
8. Adjust the door position.

Tighten the screws.

Check that the door swings freely and closes properly. It may be necessary to adjust the door latch to get proper fit and operation.

26.1 LATCH MECHANISM ADJUSTMENT

To adjust the latch mechanism and the striker pin:

1. Open the door to access the striker pin.
2. Loosen slightly the striker pin.

3. Using a hammer, adjust the striker pin to center it in the door latch mechanism.
4. Tighten the striker pin.

Check door fit and operation.

27. FENDERS

On the "H" series vehicle, all fenders are easily removable for maintenance on brakes and suspension. Each rear fender has three mechanical spring-loaded holding devices fixing it to the vehicle's structure.

27.1 REAR FENDER REMOVAL

1. Push the spring type rod sideways so that the lock disengages.
2. Support or have somebody hold the fender up.
3. As in 1, repeat to release both remaining holding devices.
4. Holding the fender firmly, pull it down until the top edge disengages from the holding plates.

To reinstall, reverse the procedure.

27.2 FRONT FENDER REMOVAL

1. At the bottom of fender, remove the retaining screws on one side of the fender.
2. Support or have someone hold the fender up.
3. Remove the screw on the other side of the fender.
4. Pull the fender down until the top edge disengages from the holding plates.

To reinstall, reverse the procedure.

28. REAR CAP

The fiberglass rear cap does not need any maintenance except painting as needed. For minor damages, refer to section 4 "Fiberglass Repair" and section 5 "Painting". If the rear cap ever has to be replaced:

1. Remove all accessories.
2. Drill out the retaining pop rivets.
3. With a sharp edge blade, cut the seal joint and remove the rear cap.

4. With the sharp edge blade, remove as much of the remaining seal pieces as possible.
5. Sand with #120 or #150 sandpaper.
6. Wipe clean with alcohol
7. Prepare surface with SIKA #205 and let dry for a minimum of 2 minutes.
8. Install a new seal using LOCTITE 414 glue.
9. Install the rear cap and fasten with pop rivets.

Caution: Do not attempt this procedure unless you are qualified and equipped to handle this job.

29. FRONT CAP

The front cap windshield frame does not need any maintenance. It is held in place with bolts and nuts. If it ever it has to be replaced, make an appointment at a Prévost service center near you.

30. SIDE PANEL INSTALLATION PROCEDURE FOR COACHES AND VIP

Material:



		Scotchbrite gray (680226)	√	Sika 206 G+P 1 liter (683446)	√
Anti-silicone (682989)	√				
Tack cloth	√				
CHIX cloth (682384)	√				
Blue cloth (682383)	√			Sika 252 black	√
Pure water	√	Masking tape	√		

Equipment:

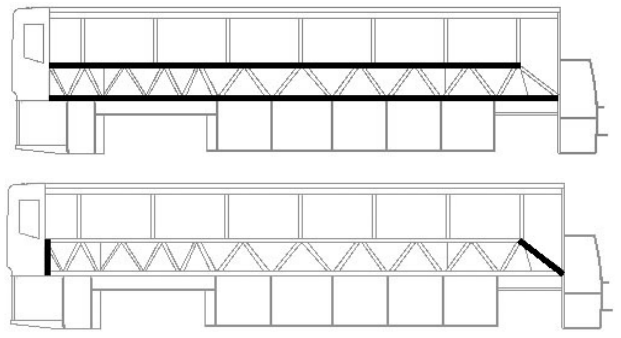
Glue gun	√	
Compression roller	√	

SECTION #1 SIDE PANEL INSTALLATION				
1.00	<table border="1" style="width: 100%; border-collapse: collapse;"> <tr> <th style="background-color: black; color: white; padding: 2px;">SS Body structure preparation</th> <td style="padding: 5px;"> <p>A) Clean using anti-silicone. See PR000001 section A. Use Scotchbrite to sand structure. Use 1 side of Scotchbrite for 1 side of vehicle.</p> </td> </tr> </table>	SS Body structure preparation	<p>A) Clean using anti-silicone. See PR000001 section A. Use Scotchbrite to sand structure. Use 1 side of Scotchbrite for 1 side of vehicle.</p>	
SS Body structure preparation	<p>A) Clean using anti-silicone. See PR000001 section A. Use Scotchbrite to sand structure. Use 1 side of Scotchbrite for 1 side of vehicle.</p>			

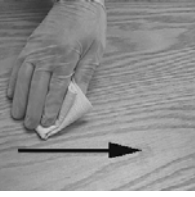
PR000001 Section A Alcohol or Anti-silicone

	1. Apply <div style="border: 1px dashed black; background-color: yellow; padding: 2px; display: inline-block;">CHIX cloth</div>		2. Dry immediately <div style="border: 1px dashed black; background-color: lightblue; padding: 2px; display: inline-block;">Blue cloth</div>
3. Allow to dry			
Mandatory	Minimum time : Wait for product to evaporate After 2 hours: Start cleaning operation again		
Before applying any other product	If surface seems dusty, greasy or with finger marks, start cleaning operation again.		

1.05	Fiberglass panel preparation (fiber side)	
A)	Clean using tack cloth. Repeat if surface seems dusty.	
B)	Clean using anti-silicone See PR000001 section A.	
C)	Apply primer 206 G+P. See PR000001 section D.	

PR000001 Section D Sika Primer 206 G+P

	3. Shake bottle to mix product 4. Apply a thin layer <div style="border: 1px dashed black; background-color: yellow; padding: 2px; display: inline-block;">CHIX cloth</div>
3. Allow to dry	
Mandatory	206 G+P Minimum time : 10 minutes After 2 hours: Remove dust using damp cloth (pure water) After 8 days : Reactivate with Aktivator as per section "C"
Before applying any other product	If surface seems dusty, dust using damp cloth. If surface seems greasy or with finger marks, reactivate with Aktivator.

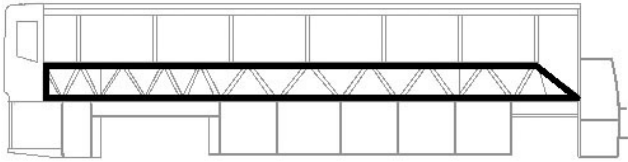
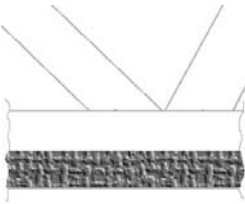
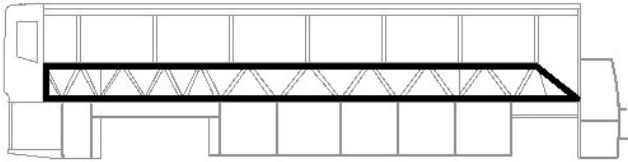

Section 18: BODY

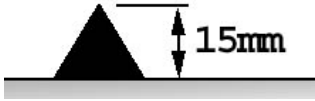
1.10	SS Body structure preparation		
	A)	Clean using anti-silicone. Clean structure at least twice. Repeat is necessary until cloth comes clean. See PR000001 section A.	
	B)	Apply 1 ¼" protective tape along bottom structural tubing.	
C)	Apply 206 G+P onto structure. See PR000001 section D.		
1.15	Install lateral panel supports onto bottom structural tubing. Install lateral panel onto supports to verify proper positioning.		

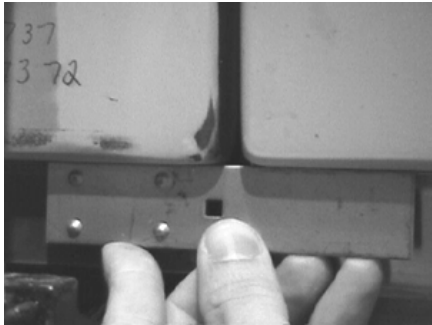
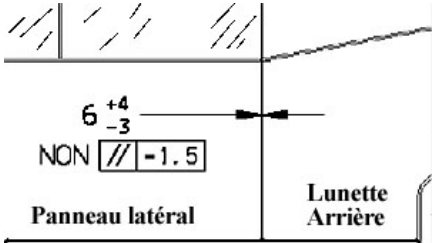
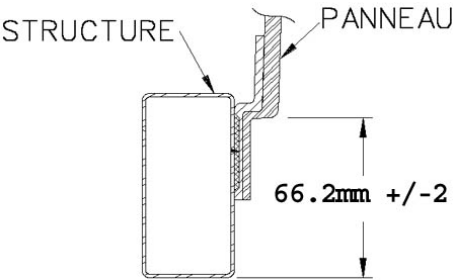
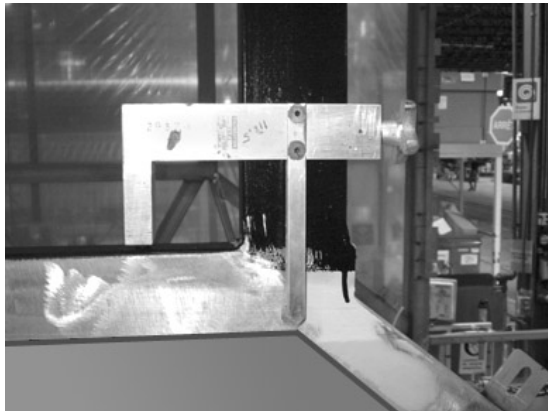
1.25	Glue application		
	A)	Set (timer) or record time.  No more than 45 minutes should elapse between beginning of glue application and panel installation.	
	B)	Apply Sika 252 black onto structure 	
1.30 *	A)	Install lateral panel onto supports and clamp panel in place using "C" clamps and square tubing to even out the pressure. Note: A maximum of clamps should be used (every 6 inches) to ensure proper bonding. Do not tighten too much.	

<p>B)</p>	<p>At the rear, adjust panel height so that it is level with rear cap</p>	
<p>C)</p>	<p>Gap between lateral panel and rear cap must be 6mm +4/-3 and panels must be aligned within 1.5mm.</p>	
<p>D)</p>	<p>Using a ruler, adjust front of lateral panel.</p>	
<p>E)</p>	<p>👁️ Verify if panel upper corner is in the middle of window post.</p>	

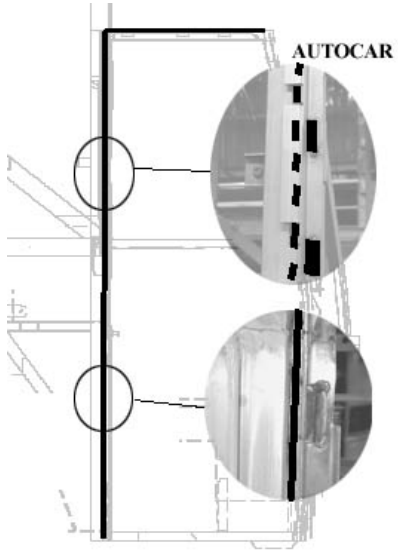
Section 18: BODY

1.35	<p>Seal entrance door perimeter using Sika 252 black, Smooth down the excess.</p>	
1.55	<p>Remove excess of glue using a spatula. Apply a bead of Sika 252 at the top of panel Spray pure water onto all the joints to speed up drying process</p>	
1.60	<p>Remove protective tape (installed at step 1.10b).</p>	
1.70	<p>Do not move the vehicle for 48 hours Make sure room temperature is superior to 20°C (68°F) before gluing Perform a visual inspection before installing side windows</p>	

<p align="center">SECTION #2 DRIP MOLDING INSTALLATION</p>			
2.00 *	A)	<p>Clean using Anti-silicone See PR000001 section A.</p>	
	B)	<p>Apply Sika 206 G+P See PR000001 section D.</p>	
2.05	<p>Remove blue paper from drip molding. Remove protective tape from double-face self adhesive tape</p>		

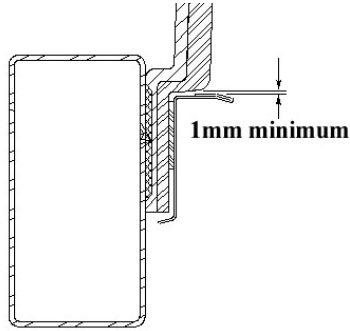
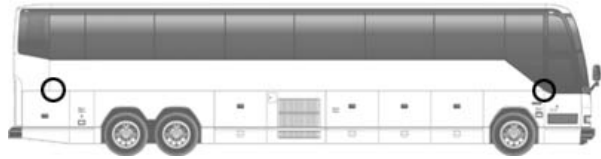
<p>2.10</p>	<p>Glue drip molding. Allow a gap of 1mm minimum between top of drip molding and panel.</p>	
<p>2.15</p>	<p>Compress drip molding using the compression roller to increase adherence.</p>	
<p>2.20</p>	<p>Round off rear and front drip molding corners.</p>	

SECTION #3 REPAIR

<p>4.00</p>	<p>Remove fiberglass from structure using a screwdriver. Use wedges if necessary to hold down panel during the work.</p>	
<p>4.05</p>	<p>Remove as much glue as possible. If primer is removed, apply primer 206 G+P locally. If primer is OK, reactivate as per PR000001 section D.</p>	
<p>4.10</p>	<p>Apply Ultrafast 2 glue (heated).</p>	
<p>4.15</p>	<p>Compress panel using clamps and a metal flat bar (for an even compression). Only use screws as a last resort to compress.</p>	
<p>4.20</p>	<p>Vehicle must not move for the next 12 hours.</p>	

31. REAR VIEW MIRRORS (RAMCO)

Your vehicle is equipped with two exterior mirrors.

The mirrors may be equipped with an optional electric heating system which serves to minimize ice and condensation on the mirror glass in extreme weather conditions. Integral thermostats are installed in both mirrors to avoid continuous heating. Use the appropriate switch on the dashboard to activate the defroster system on both mirrors simultaneously. The mirrors can easily be adjusted by using the remote controls located on the L.H. side control panel. The mirrors have easy to replace glass in case of breakage. Remote control motors can also be replaced.

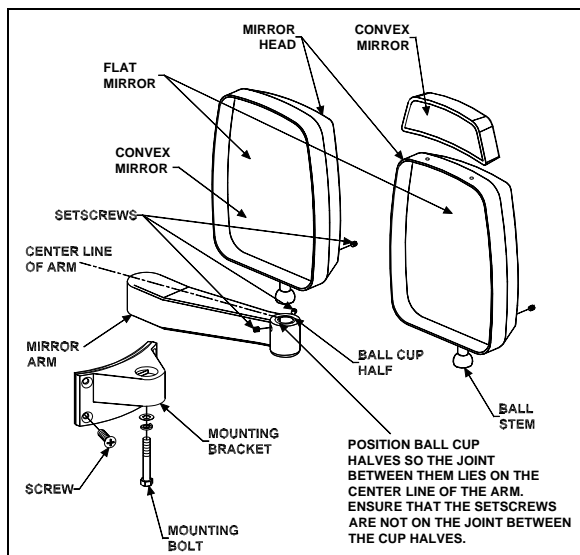

FIGURE 66: REAR-VIEW MIRROR (RAMCO) 18201

31.1 ADJUSTMENT

At the base of the mirror arm, loosen the mounting bolt to swing arm in or out.

To pivot the mirror head, loosen the setscrews on each side of the ball stub at the base of the mirror head to facilitate the adjustment.

31.2 DISASSEMBLY

At end of mirror arm, loosen the setscrews to relieve tension on the ball stem. Remove the ball stem from the arm.

Remove the four screws fastening the mirror arm base to the coach.

31.3 ASSEMBLY

Mount the mirror arm base to the coach.

Insert the ball stem into the mirror arm and tighten the socket setscrews.

Note: Position the ball cup halves so the joint between them lies on the centerline of the arm. Ensure that the setscrews are not on the joint between the cup halves.

31.4 REPLACEMENT OF MIRROR GLASS

Remove the broken glass.

Position new glass in mirror head and press to lock the Velcro in place.

31.5 HEATED / REMOTE CONTROLLED REAR VIEW MIRRORS

Heated/remote controlled external rear view mirrors may be provided to prevent the mirrors from frosting up in cold weather.

The remote controlled external rear view mirrors attach to support arms using a pivot collar secured by setscrews. Loosening the setscrews allows the whole head assembly to turn on the support arm for initial adjustment. A mounting bolt and washer hold the arm support to the mounting bracket. The arm support can be moved to position the mirror head into or away from the coach body.

The mirror heat switch is located to the left of the driver on the dashboard. This switch must be activated before the mirror heating element will energize. Once energized, the mirror heating element is kept at a sustained temperature (between 60-80°F) by a thermostat. Refer to wiring diagram annexed in the technical publication box.

Caution: Do not attach stick-on type convex mirror accessories to the heated mirror glass. This could impede uniform heat distribution on the mirror surface which could break the mirror.

31.5.1 Mirror Control

The remote control pointer knob(s) for the mirrors is (are) mounted on the L.H. side control panel. The harness to the mirror head runs through the arm support. The remote motor is mounted to the mirror head behind the mirror glass.

Turn pointer knob to the left for mirror head adjustments and to the right for convex mirror adjustment, then push down on either of the button's (4) sides to adjust the selected mirror viewing angle.

31.5.2 Disassembly

At end of mirror arm, loosen the setscrews to relieve tension on the ball stud. Remove the ball stud. Remove the ball stud from the arm and gently pull the harness out until the connector is exposed.

Remove the four screws fastening the mirror arm base to the coach. Slide the harness free of the mirror arm base.

31.5.3 Assembly

Attach a stiff wire (snake) to the end of the harness and insert the wire through the mirror arm base and arm, gently pull the harness through the arm and disconnect the "snake".

Connect the mirror head harness. Insert the harness connector back into the mirror arm.

Insert the ball stud into the mirror arm and tighten the socket setscrews.

Note: Position the ball cup halves so the joint between them lies on the centerline of the arm. Ensure that the setscrews are not on the joint between the cup halves.

31.5.4 Convex & Flat Mirror Removal

The mirror glass assembly is mounted to the control mechanism or to mirror base with Velcro strips. Remove the mirror glass by gently pulling the lens to release the Velcro. Disconnect the heater grid at the two connectors.

Connect the connectors of the new mirror's grid to the harness. Install the lens by positioning the lens in the mirror frame and pressing to lock the Velcro in place.

32. VEHICLE JACKING POINTS

The vehicle can be lifted by applying pressure under body jacking points or front and drive axle jacking points (Fig. 67, 68, 69, 70). When it is necessary to lift the vehicle, care should be taken to ensure that the pressure is applied only on the specified areas. Equipment for lifting the front of the vehicle must have a combined lifting capacity of at least 20,000 lb. (9 100 kg). Equipment for lifting the rear of the vehicle must

have a combined lifting capacity of at least 40,000 lb. (18 200 kg).

Warning: DO NOT tow or jack vehicle with people on board.

Warning: When it is necessary to raise the vehicle, care should be taken to ensure that pressure is applied only at the points indicated in figures 67, 68, 69 and 70.

Warning: Extra lift capacity may be required if luggage or any other type of load (e.g. conversion equipment) are onboard the vehicle.

Caution: The suspension of the vehicle must be in the normal ride position before jacking. The "Level Low" system on a motorcoach must be in the "DRIVE" position prior to turning the ignition key "OFF".

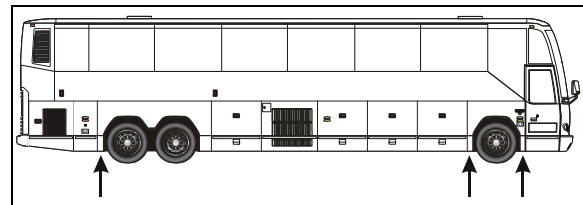

FIGURE 67: JACKING POINTS ON STRUCTURE 18480

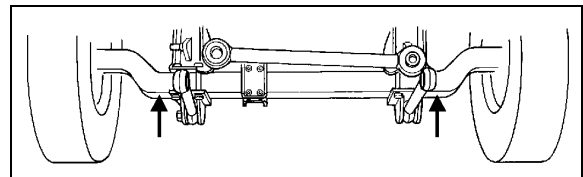

FIGURE 68: JACKING POINTS ON FRONT AXLE 18084

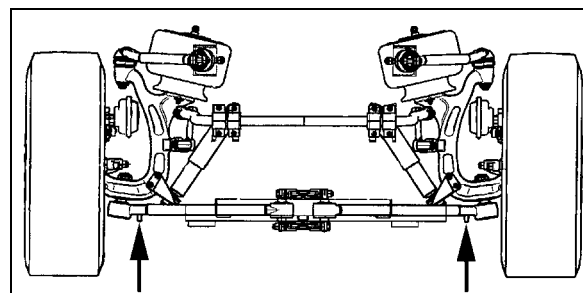

FIGURE 69: JACKING POINTS ON IND. SUSPENSION

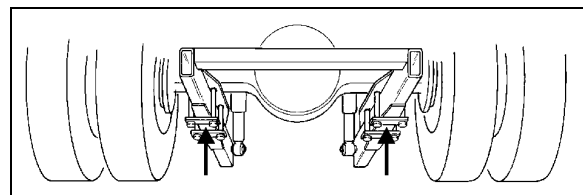

FIGURE 70: JACKING POINTS ON DRIVE AXLE 18085

Caution: Always unload or retract the tag axle before jacking the vehicle from the front and drive axle jacking points to prevent damage to suspension components.

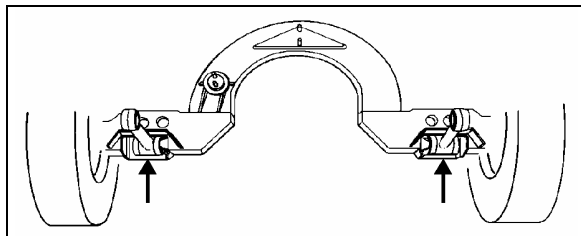

FIGURE 71: JACKING POINTS ON TAG AXLE 18086

Caution: The jacking points on the tag axle must be used for raising the tag axle only.

33. TOWING THE VEHICLE

The vehicle can be transported on a low bed semi-trailer of adequate gross axle weight capacity. When transporting a vehicle, apply parking brake and shut down the engine. Block all wheels and secure vehicle with tie-downs. Check that overall height will clear obstacles on the route to follow, and obtain required permits.

The vehicle can also be towed by lifting the front axle or by towing from the front with all wheels on the ground. These two methods are described below under their respective headings. Whatever the method used, the vehicle should be towed by truck operators authorized and experienced in towing highway coaches.

Observe normal precautions including, but not limited to, the ones listed below when towing the vehicle:

- Make sure the parking brake is released before towing.
- Do not allow passengers to ride onboard the towed vehicle.
- Tow the vehicle at a safe speed as dictated by road and weather conditions.
- Accelerate and decelerate slowly and cautiously.

33.1 LIFTING AND TOWING

The towed vehicle must be lifted from under the front axle only. The tow truck must be equipped with the proper lifting equipment to reach under the front axle since no other lifting points are

recommended. Lifting and towing from any other point are unauthorized as it may cause serious damage to the structure. Do not unload or raise the tag axle when lifting and towing to prevent overloading the drive axle.

1. Remove both drive axle shafts to prevent damage to the transmission. Plug axle tube to prevent oil loss. Refer to Rockwell's "Maintenance manual no.5" annexed at the end of Section 11, Rear axle, in this manual for correct procedure.

Caution: Transmission lubrication is inadequate when towing. With either automatic, semi-automatic or manual transmission, the drive axle shafts must be removed to avoid serious damage to the transmission.

2. Operate the engine when towing to maintain brake system air pressure. If the engine cannot be operated, connect an external air pressure line from the tow truck to the emergency fill valve in the engine compartment. The emergency fill valve in the front service compartment does not supply air pressure to the brake system. The air pressure must be a minimum of 75 psi (520 kPa), and the line should be attached to the air line with a clip-on chuck.

Caution: Do not tow the vehicle without external air pressure applied to the emergency fill valve if the engine does not operate. Without brake system air pressure, the brakes may apply automatically if system air drops below 40 psi (275 kPa). If failure prevents releasing the parking brakes with air pressure, disengage the parking brakes mechanically.

3. Lift the vehicle from under the front axle, and adequately secure the underside to the tow vehicle lifting attachment with chains.
4. Observe safety precautions when towing.

33.2 TOWING WITHOUT LIFTING

Caution: When towing vehicle without lifting, use only a tow truck with a solid link tow bar and related equipment. All other means of towing are unauthorized. Tow only from the front of the vehicle.

1. Remove both drive axle shafts to prevent damage to the transmission. Plug axle tube to prevent oil loss. Refer to Rockwell's "Maintenance manual no.5" annexed at the

end of Section 11, Rear axle, in this manual for correct procedure.

Caution: Transmission lubrication is inadequate when towing. With either automatic, semi-automatic or manual transmission, the drive axle shafts must be removed to avoid serious damage to the transmission.

- Operate the engine when towing to maintain brake system air pressure. If the engine cannot be operated, connect an external air pressure line from the tow truck to the emergency fill valve in the engine compartment. The emergency fill valve in the front service compartment does not supply air pressure to the brake system. The air pressure must be a minimum of 75 psi (520 kPa), and the line should be attached to the air line with a clip-on chuck.

Caution: Do not tow the vehicle without external air pressure applied to the emergency fill valve if the engine does not operate. Without brake system air pressure, the brakes may apply automatically if system air drops below 40 psi (275 kPa). If failure prevents releasing the parking brakes with air pressure, disengage the parking brakes mechanically.

- Position the tow truck so that the tow bar contacts the front bumper of the vehicle.
- Attach the tow truck chains only in the tow eyes of the vehicle under the bumper and take up all the slack.
- Attach safety chains as applicable.
- Observe safety precautions when towing.

34. SPECIFICATIONS

Door cylinder

ManufacturerBimba
 Type Pneumatic
 I.D. 1½" (mm)
 Stroke..... 8" (mm)
 Prévost number..... 780595

Damper

ManufacturerKoni
 Prévost number..... 780565

Lock cylinder (upper)

ManufacturerBimba
 Type Air, single action, 1/8 NPT, hexagonal rod
 I.D. 7/8" (22 mm)
 Stroke..... 1" (25 mm)
 Supplier number..... D-51127-A
 Prévost number..... 641392

Lock cylinder (central)

ManufacturerBimba
 TypeAir, single action, ¼ NPT
 I.D. 1¼" (45 mm)
 Stroke..... 1" (25 mm)
 Supplier number..... 241-P
 Prévost number..... 641209

Manifold solenoid

Manufacturer Norgren
 Type 4 ports, 1/8 NPT
 Voltage..... 24 VDC
 Power consumption..... 6 watts

Section 18: BODY

Maximum pressure..... 150 psi (1035 kPa)
Prévost number..... 641448

Solenoid valve (Latching valve)

Manufacturer Humphrey
Model 310
Operating range 0 to 125 psi (0 to 860 kPa)
Voltage 24 VDC
Voltage tolerance +10%, -15% of rated voltage
Power consumption..... 4 watts
Leak rate (max allowed) 0.245 in³/min @ 100 psi (4cc/min @ 690 kPa)
Type of operation Direct solenoid
Lubrication..... Not required (factory pre-lubed)
Filtration 40 micron recommended
Prévost number..... 641412

Pressure switch assembly

Prévost number..... 452831