

# SECTION 22: HEATING AND AIR CONDITIONING

## CONTENTS

<b>1. HEATING AND AIR CONDITIONING .....</b>	<b>6</b>
<b>2. AIR CIRCULATION WITH CENTRAL SYSTEM .....</b>	<b>6</b>
2.1 DRIVER'S AREA.....	6
2.1.1 COACHES .....	6
2.1.2 VIP .....	6
2.2 CENTRAL AREA (PASSENGER/CABIN).....	6
<b>3. AIR CIRCULATION WITH SMALL SYSTEM .....</b>	<b>8</b>
3.1 AUXILIARY SYSTEM .....	8
<b>4. SMALL HVAC SYSTEM OPERATION.....</b>	<b>8</b>
4.1 AUXILIARY SYSTEM OPERATION .....	8
<b>5. CENTRAL HVAC SYSTEM OPERATION.....</b>	<b>8</b>
5.1 DRIVER'S AREA.....	8
5.2 CENTRAL AREA.....	8
5.3 PARCEL RACK A/C (H3 COACHES) .....	9
<b>6. HVAC UNIT MAINTENANCE.....</b>	<b>9</b>
6.1 COIL CLEANING.....	10
6.2 DRIVER'S HVAC UNIT AIR FILTERS.....	10
6.3 CENTRAL HVAC UNIT AIR FILTER.....	11
6.4 PARCEL RACK FAN AIR FILTER.....	11
<b>7. DIAGNOSIS OF MAIN HVAC UNIT PROBLEMS .....</b>	<b>11</b>
7.1 TROUBLESHOOTING MODE .....	11
7.2 CONTINUITY CHECK .....	12
<b>8. EVAPORATOR MOTOR .....</b>	<b>13</b>
8.1 REMOVAL.....	13
8.2 INSTALLATION .....	13
8.3 CHECKING OPERATION OF BRUSH IN HOLDER.....	13
8.4 BRUSH WEAR INSPECTION AND REPLACEMENT .....	13
8.5 BRUSH OLDER ADJUSTMENT.....	14
8.6 CHECKING COMMUTATOR .....	14
<b>9. CENTRAL AIR CONDITIONING SYSTEM .....</b>	<b>14</b>
9.1 A/C CYCLE .....	14
9.2 REFRIGERANT .....	15
9.2.1 PROCUREMENT .....	15
9.2.2 PRECAUTIONS IN HANDLING REFRIGERANT.....	15
9.2.3 TREATMENT IN CASE OF INJURY.....	15
9.2.4 PRECAUTIONS IN HANDLING REFRIGERANT LINES.....	15
9.3 REFRIGERANT SYSTEM CLEAN-OUT AFTER COMPRESSOR FAILURE.....	16
9.3.1 DETERMINING SEVERITY OF FAILURE.....	16
9.3.2 CLEAN-OUT AFTER MINOR COMPRESSOR FAILURE .....	16
9.3.3 CLEAN-OUT AFTER MAJOR COMPRESSOR FAILURE.....	17
9.4 PUMPING DOWN .....	17
9.5 ADDING REFRIGERANT (VAPOR STATE).....	20

## Section 22: HEATING AND AIR CONDITIONING

---

9.6	EVACUATING SYSTEM .....	20
9.6.1	DOUBLE SWEEP EVACUATION PROCEDURE.....	20
9.7	CHARGING SYSTEM.....	21
<b>10.</b>	<b>CENTRAL A/C SYSTEM COMPONENTS.....</b>	<b>22</b>
10.1	COMPRESSOR (CENTRAL SYSTEM).....	22
10.1.1	BELT REPLACEMENT.....	22
10.1.2	PULLEY ALIGNMENT.....	23
10.1.3	LONGITUDINAL COMPRESSOR ALIGNMENT.....	23
10.1.4	HORIZONTAL COMPRESSOR ALIGNMENT.....	23
10.1.5	VERTICAL COMPRESSOR ALIGNMENT.....	23
10.1.6	COMPRESSOR MAINTENANCE.....	23
10.1.7	TROUBLESHOOTING GUIDE.....	25
10.2	MAGNETIC CLUTCH.....	25
10.2.1	HVAC CONTROL UNIT AND CLUTCH OPERATION.....	25
10.3	CONDENSER.....	26
10.3.1	CONDENSER FAN MOTORS.....	26
10.3.2	CONDENSER FAN MOTOR REMOVAL.....	26
10.3.3	PRELIMINARY DISASSEMBLY.....	26
10.3.4	DISASSEMBLY.....	27
10.4	RECEIVER TANK.....	27
10.5	FILTER DRYER.....	27
10.5.1	REPLACEMENT.....	27
10.5.2	MOISTURE INDICATOR.....	28
10.6	LIQUID REFRIGERANT SOLENOID VALVE.....	28
10.6.1	MANUAL BYPASS.....	28
10.6.2	COIL REPLACEMENT.....	28
10.6.3	VALVE DISASSEMBLY.....	28
10.6.4	VALVE REASSEMBLY.....	29
10.7	EXPANSION VALVE.....	29
10.7.1	CENTRAL SYSTEM.....	29
10.7.2	DRIVER'S SYSTEM.....	32
10.8	TORCH BRAZING.....	32
10.9	TROUBLESHOOTING.....	33
10.9.1	EXPANSION VALVE.....	33
10.9.2	A/C.....	34
10.10	TEMPERATURES & PRESSURES.....	36
10.11	LEAK TESTING.....	37
<b>11.</b>	<b>VIP DRIVER'S AIR CONDITIONING SYSTEM AND COMPONENTS.....</b>	<b>37</b>
11.1	COMPRESSOR.....	37
11.2	MAGNETIC CLUTCH.....	37
11.3	MAINTENANCE PRECAUTIONS.....	38
11.3.1	WORK AREA.....	38
11.3.2	REFRIGERANT HANDLING.....	38
11.3.3	PAG OIL HANDLING.....	38
11.3.4	REFRIGERANT RECOVERY.....	38
11.3.5	COMPRESSOR HANDLING.....	38
11.4	COMPRESSOR REMOVAL.....	39
11.4.1	WHEN THE COMPRESSOR IS OPERATIONAL.....	39
11.4.2	WHEN THE COMPRESSOR IS INOPERABLE.....	39
11.5	INSTALLATION PRECAUTIONS.....	39
11.6	COMPRESSOR OIL CHANGE.....	39

## Section 22: HEATING AND AIR CONDITIONING

11.6.1	EVACUATING SYSTEM BEFORE ADDING REFRIGERANT (DRIVER'S OR AUXILIARY SYSTEM)	40
11.7	OIL ADDITION	40
11.8	COMPRESSOR OIL CONTAMINATION	41
11.9	OIL RETURN OPERATION	41
11.10	OIL CHECK INTERVAL	41
11.11	LEAK TEST PROCEDURE WITH COMPRESSOR REMOVED	41
11.12	TIGHTENING TORQUES	42
<b>12.</b>	<b>HEATING SYSTEM</b>	<b>42</b>
12.1	SMALL HEATING & AUX. SYSTEM	44
12.2	CENTRAL HEATING SYSTEM	44
12.3	DRAINING HEATING SYSTEM	44
12.3.1	DRAINING DRIVER'S HEATER CORE	44
12.3.2	DRAINING MAIN HEATER CORE	44
12.4	FILLING HEATING SYSTEM	46
12.5	BLEEDING HEATING SYSTEM	46
12.6	SOLDERING	46
12.7	DRIVER'S WATER SOLENOID VALVE	46
12.7.1	IMPROPER OPERATION	46
12.7.2	COIL REPLACEMENT	47
12.7.3	VALVE DISASSEMBLY	47
12.7.4	VALVE REASSEMBLY	47
12.8	CENTRAL HOT WATER PNEUMATIC VALVE ASSEMBLY	49
12.8.1	DESCRIPTION	49
12.8.2	PNEUMATIC WATER VALVE DISASSEMBLY	49
12.8.3	PNEUMATIC WATER VALVE REASSEMBLY	50
12.8.4	PILOT SOLENOID VALVE	50
12.8.5	VALVE TROUBLESHOOTING	50
12.9	WATER RECIRCULATING PUMP	50
12.9.1	REMOVAL	50
12.9.2	DISASSEMBLY	51
12.9.3	BRUSHES	51
12.9.4	BEARINGS	53
12.9.5	COMMUTATOR	53
12.9.6	MISCELLANEOUS	53
12.9.7	ASSEMBLY	53
12.9.8	INSTALLATION	54
12.10	WATER FILTER	54
12.10.1	MAINTENANCE	54
12.10.2	FILTER SERVICING	54
12.11	BYPASS SOLENOID WATER VALVE (OPTIONAL)	55
12.11.1	TO REMOVE OR CHANGE THE COIL	55
12.11.2	VALVE DISASSEMBLY AND REASSEMBLY	55
<b>13.</b>	<b>PREHEATING SYSTEM (OPTIONAL ON COACHES ONLY)</b>	<b>55</b>
13.1	OPERATION	56
13.2	PREHEATING SYSTEM TIMER	57
13.2.1	TIMER OPERATING INSTRUCTIONS (WEBASTO)	57
13.3	TROUBLESHOOTING AND MAINTENANCE	58
<b>14.</b>	<b>SPECIFICATIONS</b>	<b>59</b>

## ILLUSTRATIONS

## Section 22: HEATING AND AIR CONDITIONING

---

figure 1: DRIVER'S AIR CIRCULATION .....	22-6
figure 2: CENTRAL HVAC SYSTEM AIR CIRCULATION .....	22-7
figure 3: PARCEL RACK VENTILATION SYSTEM.....	22-8
figure 4: HVAC DASHBOARD CONTROL UNIT .....	22-8
figure 5: HVAC DASHBOARD CONTROL UNIT .....	22-8
figure 6: MAIN BREAKERS .....	22-9
figure 7: LOCATION OF RELAYS AND RESISTORS .....	22-9
figure 8: PARCEL RACK A/C INSTALLATION .....	22-9
figure 9: EVAPORATOR COIL .....	22-10
figure 10: CONDENSER COIL .....	22-10
figure 11: DRIVER'S CONSOLE ACCESS GRILL .....	22-10
figure 12: VIP CONSOLE ACCESS GRILL .....	22-11
figure 13: DRIVER'S AREA AIR FILTERS .....	22-11
figure 14: MAIN HVAC UNIT AIR FILTER .....	22-11
figure 15: PARCEL RACK FAN AIR FILTER.....	22-11
figure 16: HVAC COMPARTMENT.....	22-13
figure 17: EVAPORATOR MOTOR ASSEMBLY.....	22-13
figure 18: EVAPORATOR MOTOR .....	22-14
figure 19: CENTRAL A/C SYSTEM COMPONENTS .....	22-19
figure 20: DOUBLE SWEEP EVACUATION SET-UP .....	22-21
figure 21: TENSIONING VALVE .....	22-22
figure 22: TENSIONING AIR BELLOWS.....	22-22
figure 23: COMPRESSOR ALIGNMENT .....	22-23
figure 24: COMPRESSOR ALIGNMENT .....	22-23
figure 25: EXPLODED VIEW OF 05G COMPRESSOR.....	22-24
figure 26: CONDENSER FAN SPEED IN RELATION WITH HIGH SIDE PRESSURE .....	22-26
figure 27: CONDENSER FAN MOTOR .....	22-26
figure 28: A/C CONDENSER COMPARTMENT .....	22-27
figure 29: REFRIGERANT SOLENOID VALVE .....	22-29
figure 30: EXPANSION VALVE .....	22-29
figure 31: SUPERHEAT ADJUST. INSTALLATION.....	22-30
figure 32: HIGH & LOW SWING TEMPERATURE AT REMOTE BULB.....	22-31
figure 33: SELTEC TM-16HD COMPRESSOR .....	22-38
figure 34: COMPRESSOR REMOVAL .....	22-39
figure 35: LOOSENING THE DISCHARGE SIDE CONNECTOR'S CAP .....	22-39
figure 36: ROTATING MAGNETIC CLUTCH .....	22-39
figure 37: COMPRESSOR INSTALLATION.....	22-39
figure 38: COMPRESSOR OIL LABEL .....	22-40
figure 39: DRAINING THE OIL .....	22-40
figure 40: ADDING NEW COMPRESSOR OIL.....	22-40
figure 41: ADDING OIL AFTER REPLACING A COMPONENT .....	22-41
figure 42: DISCHARGE AND SUCTION CAPS .....	22-41
figure 43: TIGHTENING TORQUES .....	22-42
figure 44: SMALL A/C & HEATING SYSTEMS PLUS AUXILIARY SYSTEM COMPONENTS.....	22-43
figure 45: CEILING OF SPARE WHEEL COMPART .....	22-44
figure 46: DRIVER'S HVAC UNIT .....	22-44
figure 47: CENTRAL HEATING SYSTEM COMPONENTS.....	22-45
figure 48: HVAC COMPARTMENT.....	22-46
figure 49: DRIVER'S WATER SOLENOID VALVE .....	22-48
figure 50: CENTRAL HOT WATER PNEUMATIC VALVE ASSEMBLY.....	22-49
figure 51: PNEUMATIC WATER VALVE .....	22-49
figure 52: VIP WATER RECIRCULATION PUMP INSTALLATION .....	22-50
figure 53: WATER RECIRCULATING PUMP .....	22-50

**Section 22: HEATING AND AIR CONDITIONING**

---

figure 54: WATER FILTER ..... 22-55  
figure 55: WEBASTO PREHEATER (104,000 BTU) ..... 22-56  
figure 56: WEBASTO ..... 22-57

## Section 22: HEATING AND AIR CONDITIONING

### 1. HEATING AND AIR CONDITIONING

The coach's interior is pressurized by its Heating, Ventilation, Air Conditioning (HVAC) units. Air flow and controls divide the vehicle in two sections: driver's and Central (passenger) sections. The interior of vehicle should always be slightly pressurized to prevent dust and moisture from entering vehicle. Each section has its own fresh air, returning air and discharge air ducting. The exhaust is mainly done through the lavatory ventilator and through normal air-tightness losses.

### 2. AIR CIRCULATION WITH CENTRAL SYSTEM

#### 2.1 DRIVER'S AREA

Fresh air is taken from a plenum behind the front bumper and enters the mixing box through an ON/OFF damper. Returning air is taken through a front dash panel into the mixing box. The driver's REcirculation button is located on the R.H. dashboard control panel (Fig. 4). Mixed air goes through cooling and heating coils, fans and discharge ducts.

Both right and left discharge ducts defrost one half of the windshield. The driver can also, with the "Main Windshield Defroster" control divert his air flow to the console, from which he can direct vent to his knees and/or upper body with adjustable HVAC register and to his feet with the appropriate button (see Fig. 1 and Operator's manual or Owner's manual).

##### 2.1.1 Coaches

Two additional air outlets are supplied by the Central HVAC ducting system. One is located in the stepwell. The flow comes from the left side and is drawn from the first step riser. The other air outlet is located behind the driver, on his L.H. side. The air outlets can be rotated to direct Air flow. Optionally, the coach may be equipped with a de-icing system in the windshield upper-section, refer to paragraph: "Central Heating System" for more information.

##### 2.1.2 VIP

VIP vehicles equipped with a central system have two additional registers located near the entrance door, at bottom of first lateral window.

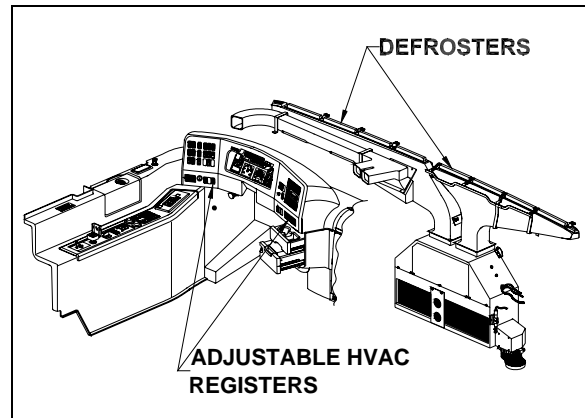

FIGURE 1: DRIVER'S AIR CIRCULATION

22121

#### 2.2 CENTRAL AREA (Passenger/Cabin)

Fresh air is taken from the left side of vehicle through a two-position damper located at the left of the HVAC compartment. The thermal control damper can be fully opened for normal operation or partially closed for extreme weather or highly polluted areas. The "Recirc." push-button switch is located on the HVAC control unit. Press down the push-button to partially close the fresh air damper.

**Note:** Opening the entrance door also partially closes the fresh air damper.

Return air is drawn through the last entrance step riser and from the lower section of the floor ducts in two locations: one in the rear section of vehicle and the other in the front section of vehicle on the L.H. side (Fig. 2).

A double blower fan unit, which is activated by the evaporator motor, draws mixed air through an air filter, cooling and heating coils, then forces this air in the ventilation ducts (upper section) along the walls, and finally exhausts it at the bottom of the windows.

On coaches, the HVAC system includes a parcel rack ventilation system equipped with adjustable registers in the parcel racks to control air flow for the passenger seats. One register per seat direct air flow by pointing or rotating register. Open or close register to adjust air flow (Fig. 3).

Also on coaches, the lavatory ventilator acts as the main exhaust for the whole vehicle, eliminates odors, and finally heats or cools the lavatory with the vehicle's ambient air.

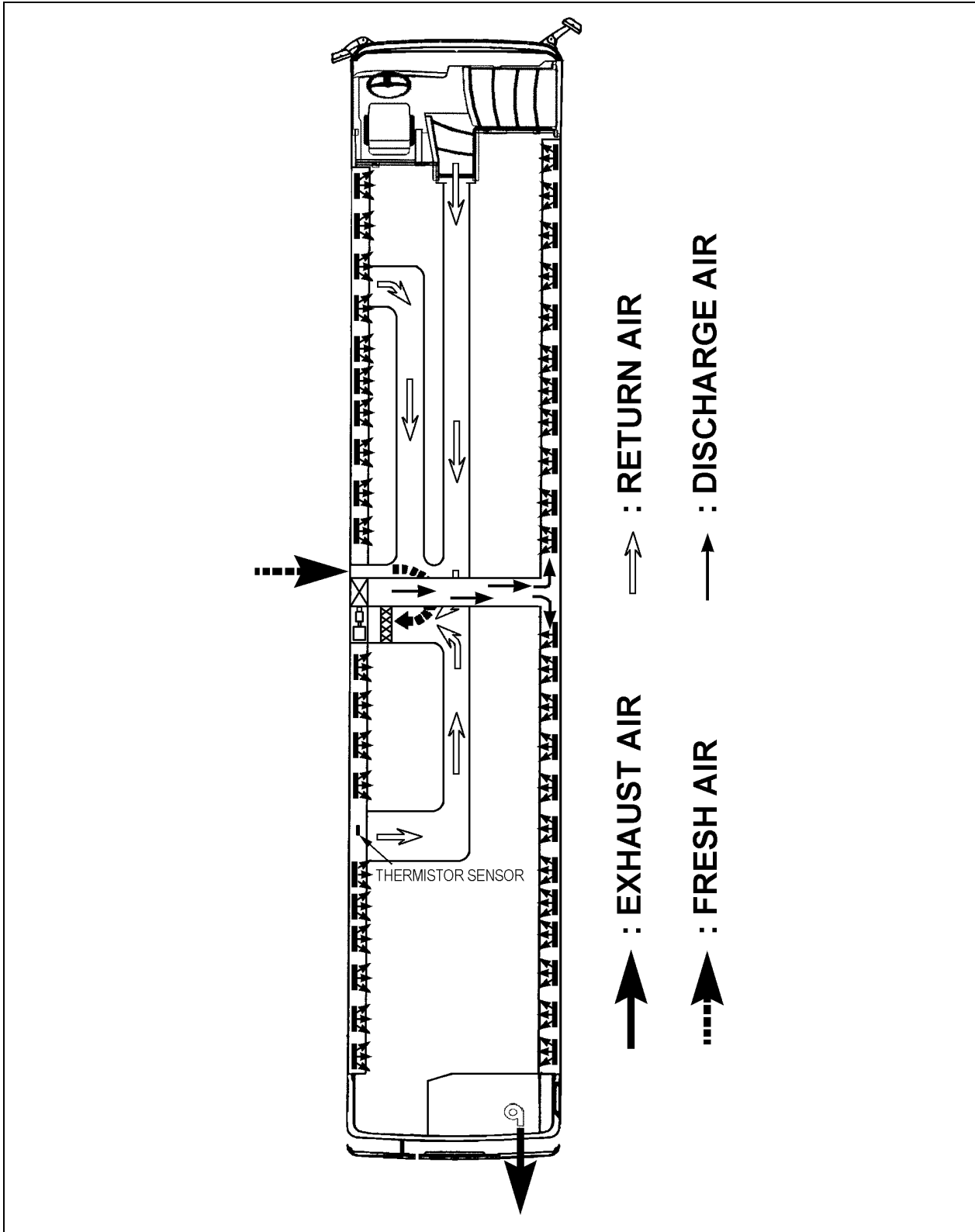

FIGURE 2: CENTRAL HVAC SYSTEM AIR CIRCULATION

22234

## Section 22: HEATING AND AIR CONDITIONING

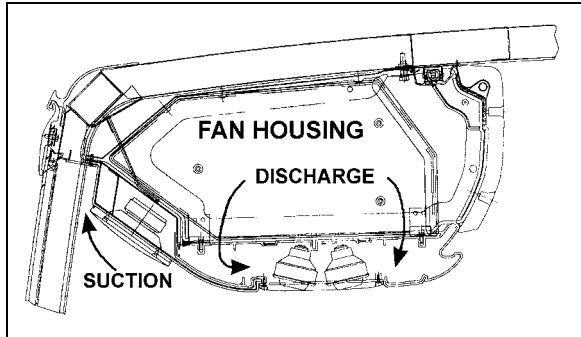

FIGURE 3: PARCEL RACK VENTILATION SYSTEM

### 3. AIR CIRCULATION WITH SMALL SYSTEM

Fresh air is taken from a plenum behind the front bumper and enters the mixing box through an adjustable damper. Returning air is taken through a front dash panel into the mixing box. The driver's RECirculation button is located on the R.H. dashboard control panel (Fig. 4). Mixed air goes through cooling and heating coils, fans and discharge ducts.

Both right and left discharge ducts defrost one half of the windshield. The driver can also, with the "Main Windshield Defroster" control divert his air flow to the console, from which he can direct vent to his knees and/or upper body with adjustable HVAC register and to his feet with the appropriate button (see Fig.1 and Owner's manual).

#### 3.1 AUXILIARY SYSTEM

VIP vehicles are equipped with an auxiliary system that provides five additional registers. Three are located behind the driver's seat and the other two are located near the entrance door, at bottom of first lateral window.

### 4. SMALL HVAC SYSTEM OPERATION

The temperature control in the driver's area is provided directly by the HVAC control unit mounted on the dashboard R.H. side.

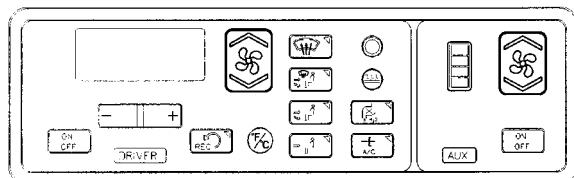

FIGURE 4: HVAC DASHBOARD CONTROL UNIT 22184

Using the Up/Down type switch sets the fan speed and the speed chosen is illustrated on the window display.

#### 4.1 AUXILIARY SYSTEM OPERATION

The temperature control is provided by the small system HVAC control unit. The R.H. portion of the HVAC control unit enables to actuate the Aux. System and to regulate the fan speed. Using the Up/Down type switch sets the fan speed and the speed chosen is illustrated on the window display.

### 5. CENTRAL HVAC SYSTEM OPERATION

#### 5.1 DRIVER'S AREA

The temperature control in the driver's area is provided directly by the L.H. portion of the HVAC control unit mounted on the dashboard R.H. side.

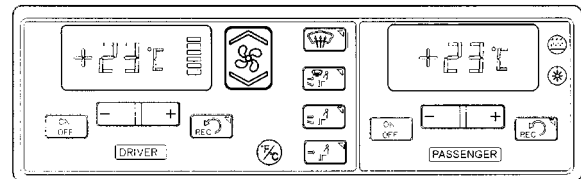

FIGURE 5: HVAC DASHBOARD CONTROL UNIT 22184

Using the Up/Down type switch sets the fan speed and the speed chosen is illustrated on the window display.

The driver's HVAC unit piping is paralleled with the main HVAC unit piping. Both units use the same refrigerant and coolant, and are linked to the same condenser and compressor, even if they are individually controlled. It requires the main HVAC unit to engage the A/C compressor magnetic clutch, consequently, the driver's unit cannot be operated alone in the A/C mode.

#### 5.2 CENTRAL AREA

The R.H. portion of the HVAC control unit located on the dashboard R.H. side, enables the selection of the temperature in the main section (Refer to the H3 Owner's or Operator's Manual for details).

Temperature control is provided in conjunction with a thermistor sensor located inside return duct, on L.H. side of vehicle (Figs. 2).



## Section 22: HEATING AND AIR CONDITIONING

The flow of water to the vehicle's main heater core is controlled by an electric water valve which varies the cycling rate depending on selected temperature. A red LED, located on HVAC control unit, illuminates when the valve is open. A green LED illuminates when compressor clutch is in operation.

The evaporator motor installed in HVAC compartment on the L.H. side of vehicle is protected by a 150 amp, manually-resettable (CB8) circuit breaker mounted in the main power compartment (refer to Section 06, "Electrical System" in this manual for details).

The condenser mounted on the opposite side of the evaporator is ventilated by two axial fans. Each axial fan motor is protected by a manually-resettable 40 amp circuit breaker (CB 77 & CB 78) mounted in the main power compartment on rear R.H. side of vehicle. (Fig. 6) Furthermore, the following relays and resistors are located in the Heating, Ventilation and Air Conditioning Compartment (HVAC) (Fig. 7). They are mounted on the control panel located on the R.H. side wall when facing the compartment:

- R39 – Condenser fan motor
- R40 – Condenser speed control HI
- R41 – Condenser speed control HI
- R50 – Evaporator fan LOW & HI speed
- R60 – Evaporator fan HI speed
- R63 – Time Delay
- RS36 – Current limit for relay
- RS37 – Current limit for relay

To operate the air conditioning system when coach is stationary, engine should run at fast idle. During operation of the air conditioning system, windows should be kept closed and door not left open longer than necessary. In order to prevent battery discharge, A/C-heating system will not operate if vehicle charging system is not working properly.

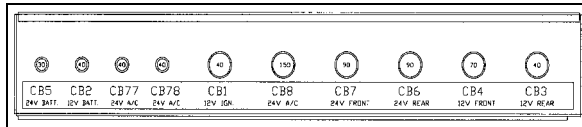

FIGURE 6: MAIN BREAKERS

06473

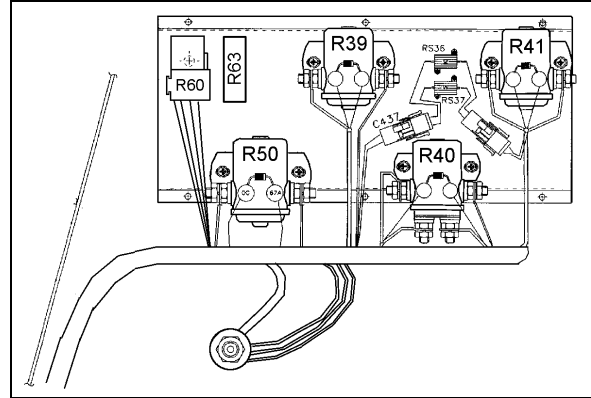

FIGURE 7: LOCATION OF RELAYS AND RESISTORS<sup>06483</sup>

### 5.3 PARCEL RACK A/C (H3 COACHES)

Optional small A/C evaporator coils may be added to both parcel racks existing air system. This air system permits a wider temperature range in the passenger's area.

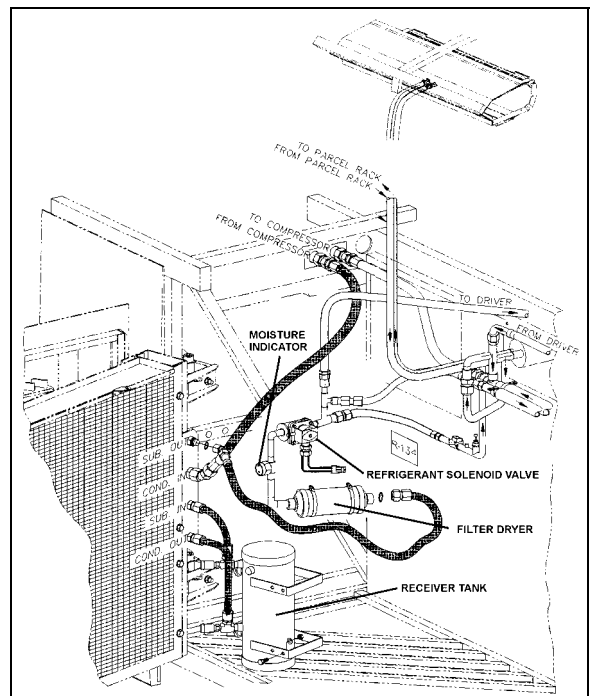

FIGURE 8: PARCEL RACK A/C INSTALLATION

22221

## 6. HVAC UNIT MAINTENANCE

No special maintenance is required on the main and driver's units, with the exception of cleaning their respective coil air filters.

## Section 22: HEATING AND AIR CONDITIONING

**Note:** Squeeze rubber hose located under the concerned compartment, to eliminate water and dirt when you make routine maintenance.

### 6.1 COIL CLEANING

Check the external surface of the coil at regular intervals for dirt or any foreign matter.

For the driver's HVAC unit, remove the grill and the access panels and back flush the evaporator coil from inside (Fig. 13).

For the optional windshield upper section defroster, remove the bottom access panel, remove the six bolts fixing the blower motor assembly. Use low air pressure to clean the coil.

For the central system evaporator coil, back flush the coil (Fig. 9) every 12,500 miles (20 000 km) or once a year whichever comes first and for the condenser, back flush the coil (Fig. 10) every 6,250 miles (10 000 km) or twice a year, whichever comes first.

Use a water jet or water mixed with low air pressure to clean the coil.

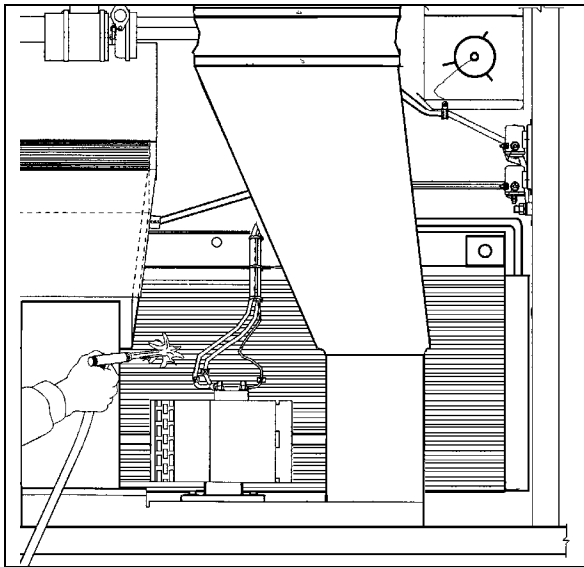

FIGURE 9: EVAPORATOR COIL

22226

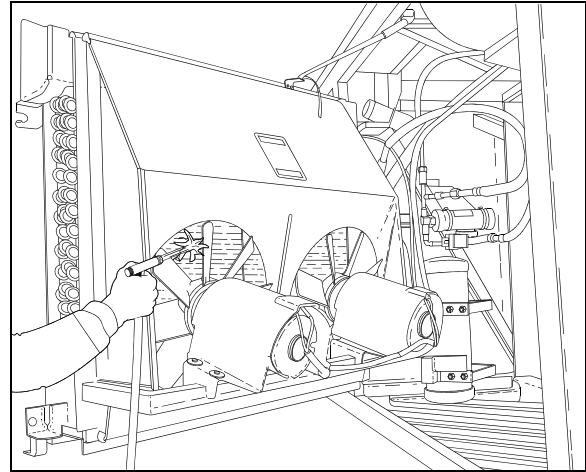

FIGURE 10: CONDENSER COIL

22170

**Caution:** Direct the pressure straight through the coil to prevent bending of fins and do not use extremely high pressure. Do not use hot water, steam or caustic soap.

### 6.2 DRIVER'S HVAC UNIT AIR FILTERS

The driver HVAC system is located behind the dashboard's R.H. side lateral plastic panel. To gain access to the A/C filters, unscrew the R.H. lateral console's grill located at the top step of the entrance door steps. Slide out the R/A and F/A filters. To clean filter back flush with water, then dry with air, every 12,500 miles (20 000 km) or once a year, whichever comes first (Fig. 11, 12 & 13).

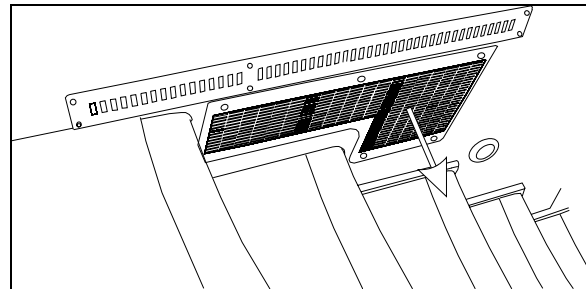

FIGURE 11: DRIVER'S CONSOLE ACCESS GRILL

18505

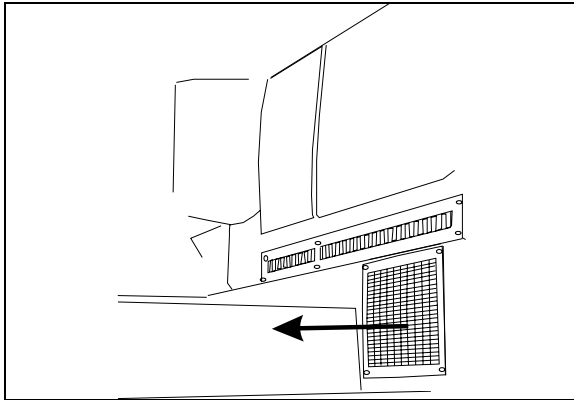

FIGURE 12: VIP CONSOLE ACCESS GRILL 22232

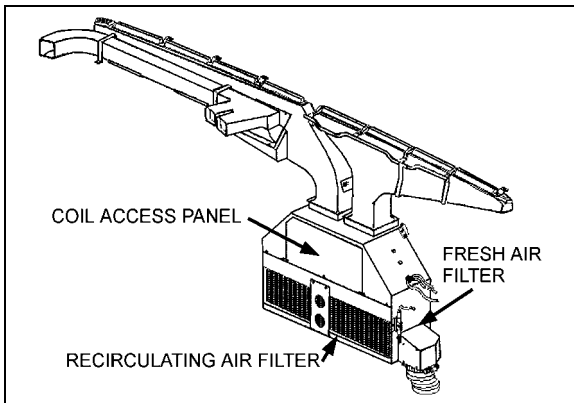

FIGURE 13: DRIVER'S AREA AIR FILTERS 22171

### 6.3 CENTRAL HVAC UNIT AIR FILTER

The main air filter is located in the HVAC compartment (Fig. 14). To access the filter, locate access panels in one of the baggage compartments adjacent to the HVAC compartments (L.H. side). Open panels by turning the three screws of either panel ¼ of a turn, unsnap both fasteners on top of filter, and slide out filter. To clean filter, back flush with water or soapy water, then dry with air every 12,500 miles (20 000 km) or once a year, whichever comes first.

**Caution:** Do not use high pressure water jet to avoid damaging filter.

**Caution:** Be sure not to reverse filter upon installation.

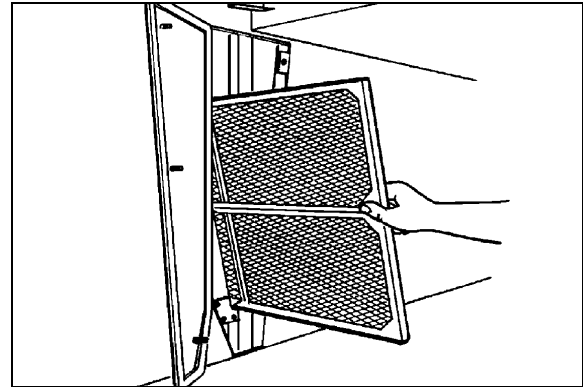

FIGURE 14: MAIN HVAC UNIT AIR FILTER 22100

### 6.4 PARCEL RACK FAN AIR FILTER

A/C evaporator coils may be installed in both parcel rack air systems. Only the air filters are serviceable. The air filters are accessible from inside the parcel racks. Slide out the filters, then back flush with water, dry with air and replace. This procedure should be done every 12,500 miles (20,000 km) or once a year, whichever come first.

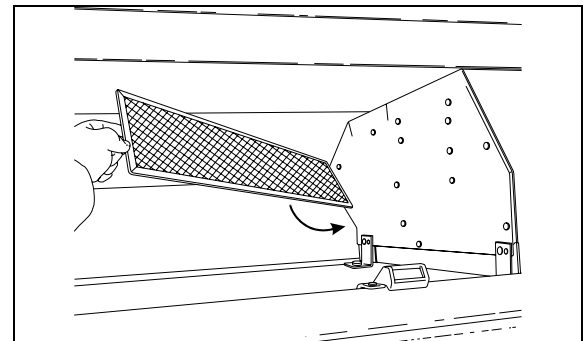

FIGURE 15: PARCEL RACK FAN AIR FILTER 22201

For A/C unit, ball valves are added on supply and return lines in the condenser compartment. They have service port to evacuate the A/C parcel rack circuit. When work has to be done on a evaporator coil unit, it will be easier to remove it and repair it on a bench.



## 7. DIAGNOSIS OF MAIN HVAC UNIT PROBLEMS

### 7.1 TROUBLESHOOTING MODE

Troubleshooting the HVAC system is made easier when entering the "Troubleshooting Mode". The Troubleshooting Mode is used while driving the vehicle to diagnose a low or high pressure in the HVAC system.

## Section 22: HEATING AND AIR CONDITIONING



To enter the Troubleshooting Mode, proceed as follows:

1. Check that HVAC system in passenger section is OFF.
2. First press  and hold, then press  and hold both buttons for 2 seconds.
3. Passenger section display should indicate 00 to show that Troubleshooting Mode is activated.

**Note:** To return to Normal Operating Mode, turn the HVAC system OFF in the passenger section.

### Low Pressure

The Telltale panel located in center dashboard

should indicate  when pressing  on

### 7.2 CONTINUITY CHECK



A continuity check is automatically performed at HVAC system start-up. If an open or short-circuit occurs, the corresponding switch LED or the display will blink for 10 seconds. The probes are checked at least every 5 minutes.

the passenger section panel if a low pressure condition is present.

**Note:** The telltale indicator will only illuminate if Troubleshooting Mode was entered and a low pressure condition is present.

### High Pressure

The Telltale panel located in center dashboard

should indicate  when pressing  on the passenger section panel if a high pressure condition is present.

**Note:** The telltale indicator will only illuminate if Troubleshooting Mode was entered and a high pressure condition is present.

Circuit	Switch LED or Display
F/A damper driver	Driver Rec
Damper mix	Driver air 4 <sup>th</sup> switch
Driver "Liquid Solenoid Valve"	Driver display "Set Point" (AC)
Driver "Hot Water Valve"	Driver display "Set Point" (HE)
Passenger "Hot Water Valve"	Passenger display "Set Point" (HE)
A/C Clutch Relay	A/C Clutch
Exterior Probe	Display "Text". (---)
Driver interior probe	Driver display "Set Point" (---)
Passenger interior probe	Passenger display "Set Point" (

## 8. EVAPORATOR MOTOR

The evaporator motor is installed in the HVAC compartment (L.H. side of vehicle) (Fig. 16). It is a 27.5 volt, 2HP (1,5 kW) motor which activates a double blower fan unit.

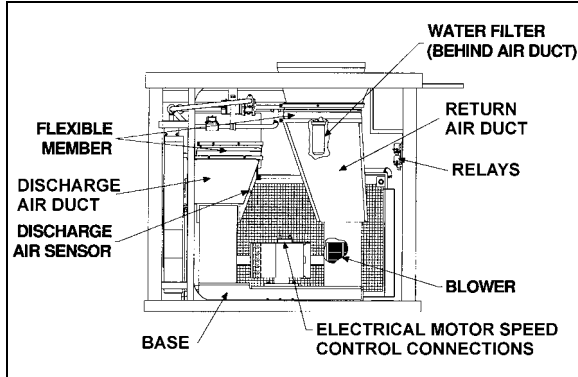

FIGURE 16: HVAC COMPARTMENT

22227

### 8.1 REMOVAL

1. Set the battery safety switch to the "OFF" position.
2. Open the last L.H. side baggage compartment door. Pull the black release button located on the L.H. side in order to unlock and open the HVAC compartment door.
3. Identify the L.H. side discharge duct inside compartment and remove the Phillips head screws fixing the air duct to blower fan.
4. Repeat step 3 for the R.H. side return air duct.
5. Disconnect electrical motor speed control connections on the motor plate.
6. From under the vehicle, remove the eight bolts fixing the double blower fan unit base. Remove the complete unit from the HVAC compartment (Fig. 17).

**Caution:** Never support evaporator motor assembly by its output shafts while moving it. Always use double blower fan unit base.

7. Install on a work bench the complete unit, unfasten the fan square head set screws, the Phillips head screws retaining cages to base and slide out the assemblies from the evaporator motor output shaft.

8. Remove motor from double blower fan unit base.

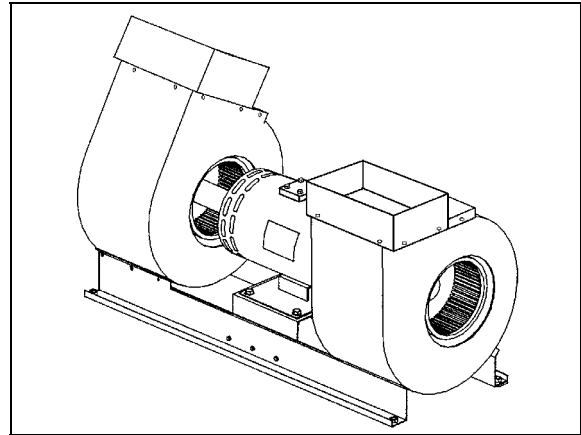

FIGURE 17: EVAPORATOR MOTOR ASSEMBLY

22228

### 8.2 INSTALLATION

To reinstall the evaporator motor, reverse "Evaporator Motor Removal" procedure.

### 8.3 CHECKING OPERATION OF BRUSH IN HOLDER

Lift brush slightly 1/8 inch (3 mm) and release it. Brush must produce a dry noise.

### 8.4 BRUSH WEAR INSPECTION AND REPLACEMENT

**Caution:** Only use replacement brushes recommended by the manufacturer. Not doing so will void warranty.

Replace the brushes if less than 3/4 inch (19 mm). New brush length is 1-1/4 inch. Clean brushes with a clean cloth impregnated with gasoline or alcohol.

**Warning:** Cleaning products are flammable and may explode under certain conditions. Always handle in a well ventilated area.

To replace brushes, proceed as follows:

1. Set battery safety switch to the "OFF" position.
2. Remove the protective screen band from the motor housing by pulling down the spring loaded fastener.
3. Lift the spring, remove and replace brushes as per the standard procedure.
4. For the installation, reverse procedure.

## Section 22: HEATING AND AIR CONDITIONING

### 8.5 BRUSH OLDER ADJUSTMENT

**Note:** The brush holders are mounted on a support that can rotate. Rotating that support will move all the brush holders at the same time.

1. Remove the screws securing the grille and remove the grille. Locate the 2 bolts fixing the mechanism permitting the rotation of the brush holder support.
2. Loosen (do not remove) the bolts just enough to release the mechanism.
3. Move gently the exposed brush holder in order to have a distance of 10mm (3/8") maximum between the brush holder face and a reference line passing through the center of the 2 bolts on the motor housing.

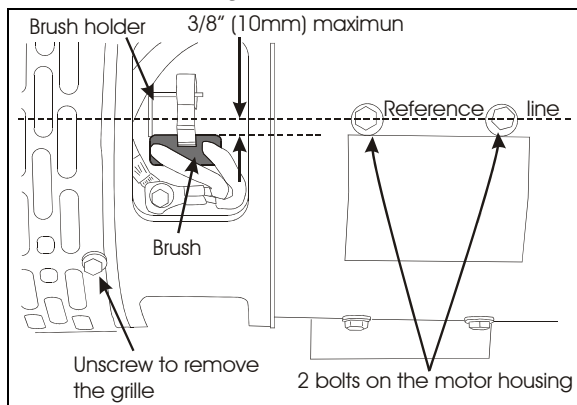

FIGURE 18: EVAPORATOR MOTOR

### 8.6 CHECKING COMMUTATOR

The surface must be polished. A brown-black colored surface is normal and indicates a good switching. Ensure there is no evidence of arcing or metal chips.

## 9. CENTRAL AIR CONDITIONING SYSTEM

The schematic of Figure 18 shows the central A/C system and its components. The central system is equipped with a 6 cylinder, 05G-134A Carrier compressor with an air conditioning capacity of 9 tons. The receiver tank and filter dryer are mounted inside the condenser compartment. The fuel filler door is a small door located at left of A/C condenser compartment door, allowing viewing of the filter dryer and the moisture indicator.

**Note:** For opening of the A/C condenser door, open the baggage compartment door at the right of the A/C condenser compartment door. The condenser compartment door must be unbolted to fully swing open.

### 9.1 A/C CYCLE

Refrigeration may be defined as "the transfer of heat from a place where it is not wanted to a place where it is unobjectionable". Components required for a closed circuit refrigeration system are shown in figure 18.

The air conditioning system used in the H3 series vehicle is the "Closed" type using "R-134a".

1. The refrigerant flowing to the compressor, is compressed to high pressure and reaches a temperature higher than the surrounding air. It is passed through the air-cooled fins and tubes of the condenser causing the hot, high pressure gas to be condensed into a liquid form.
2. The liquid refrigerant flows to the receiver tank, then back to the condenser sub-cooler. It leaves the condenser and passes through a filter dryer where moisture, acids and dirt are removed and then through a moisture indicator which indicates if any moisture is present in the system.
3. By its own pressure, the liquid refrigerant flows through a thermal expansion valve where the pressure drop causes the refrigerant to vaporize in a vapor-liquid state at a low temperature pressure.
4. The cold low pressure refrigerant passes through the main and the driver's evaporator coils which absorb heat from the air passing over the fins and tubes, and changes into gas. In this form, the refrigerant is drawn into the compressor to repeat the air conditioning cycle.
5. The success of the air conditioning system depends on retaining the conditioned air within the vehicle. All windows and intake vents should be closed. An opening of approximately 8 in<sup>2</sup> (5162 mm<sup>2</sup>) could easily neutralize the total capacity of the system.
6. Other causes of inadequate cooling are dirty coils or filter. Dirt acts as an insulation

and is also serves as a restriction to the air flow.

7. The refrigeration load is not constant and varies. It is also affected by outside temperature, relative humidity, passenger load, compressor speed, the number of stops, etc.
8. The compressor will load depending on operating conditions.

### 9.2 REFRIGERANT

The A/C system of this vehicle has been designed to use Refrigerant 134a as a medium. Regardless of the brand, only R-134a must be used in this system. The chemical name for this refrigerant is Ethane, 1, 1, 1, 2-Tetrafluoro.

**Warning:** Refrigerant in itself is nonflammable, but if it comes in contact with an open flame, it will decompose.

#### 9.2.1 Procurement

Refrigerant is shipped and stored in metal cylinders. It is serviced in 30 and 100 pound (13,6 and 45 kg) cylinders. Approximately 25 pounds (11,4 kg) are used in the central system.

It will be impossible to draw all the refrigerant out of the cylinder. However, the use of warm water when charging the system will assure the extraction of a maximum amount of refrigerant from the cylinder.

#### 9.2.2 Precautions in Handling Refrigerant

1. Do not leave refrigerant cylinder uncapped.
2. Do not subject cylinder to high temperatures, do not weld or steam clean near system or cylinder.
3. Do not fill cylinder completely.
4. Do not discharge vapor into an area where a flame is exposed.
5. Do not expose the eyes to liquid refrigerant.

All refrigerant cylinders are shipped with a heavy metal screw cap. The purpose of the cap is to protect the valve and safety plug from damage. It is a good practice to replace the cap after each use of the cylinder for the same reason. If the cylinder is exposed to the sun's radiant heat

pressure increase resulting may cause release of the safety plug or the cylinder may burst.

For the same reason, the refrigerant cylinder should never be subjected to excessive temperature when charging a system. The refrigerant cylinder should be heated for charging purposes by placing it in 125°F (52°C) water. Never heat above 125°F (52°C) or use a blowtorch, radiator, or stove to heat the cylinder.

Welding or steam cleaning on or near any refrigerant line or components of the A/C system could build up dangerous and damaging pressures in the system.

If a small cylinder is ever filled from a large one, never fill the cylinder completely. Space should always be allowed above the liquid for expansion. Weighing cylinders before and during the transfer will determine the fullness of the cylinders

**Warning:** One of the most important precautions when handling refrigerant consists in protecting the eyes. Any liquid refrigerant which may accidentally escape is approximately -40°F (-40°C). If refrigerant comes in contact with the eyes, serious injury could result. Always wear goggles to protect the eyes when opening refrigerant connections.

#### 9.2.3 Treatment in Case of Injury

If liquid refrigerant comes in contact with the skin, treat the injury as if the skin was frost-bitten or frozen. If liquid refrigerant comes in contact with the eyes, consult an eye specialist or doctor immediately. Give the following first aid treatment:

1. Do not rub the eyes. Splash eyes with cold water to gradually bring the temperature above the freezing point.
2. Apply drops of sterile mineral oil (obtainable at any drugstore) in the eyes to reduce the possibility of infection. The mineral oil will also help in absorbing the refrigerant.

#### 9.2.4 Precautions in Handling Refrigerant Lines

1. All metal tubing lines should be free of kinks, because of the resulting restrictions on the flow of refrigerant. A single kink can greatly reduced the refrigeration capacity of the entire system.

## Section 22: HEATING AND AIR CONDITIONING

---

2. The flexible hose lines should never be allowed to come within a distance of 2-½" (6,3 cm) from the exhaust manifold.
3. Use only sealed lines from parts stock.
4. When disconnecting any fitting in the refrigeration system, the system must first be discharged of all refrigerant. However, proceed very cautiously, regardless of gauge readings. If there happens to be liquid refrigerant in the line, disconnect fittings very slowly, keeping face and hands away so that no injury can occur. If pressure is noticed when fitting is loosened, allow it to bleed off very slowly.

**Warning:** Always wear safety goggles when opening refrigerant lines.

5. In the event that any line is opened to the atmosphere, it should be immediately capped to prevent entrance of moisture and dirt.
6. The use of the proper wrenches when making connections on O-ring fittings is important. The use of improper wrenches may damage the connection. The opposing fitting should always be backed up with a wrench to prevent distortion of connection lines or components. When connecting the flexible hose connections, it is important that the swaged fitting and the flare nut, as well as the coupling to which it is attached, be held at the same time using three different wrenches to prevent turning the fitting and damaging the ground seat.
7. The O-rings and seats must be in perfect condition. The slightest burr or piece of dirt may cause a leak.
8. O-rings should be coated with refrigeration oil and installed on the line before the line is inserted into the fitting to prevent damaging the O-ring. If leaks are encountered at the couplings or connectors, no attempt should be made to correct the leaks by tightening the connections beyond the recommended torque. The O-rings are designed to seal at the specified torque and overtightening the connection does not result in a satisfactory and permanently sealed connection. The connection must be disassembled and the cause of the leak (damaged O-ring,

defective lines, etc.) corrected. Use new O-ring.

### 9.3 REFRIGERANT SYSTEM CLEAN-OUT AFTER COMPRESSOR FAILURE

Although the vast majority of reciprocating refrigerant compressors manufactured today are extremely reliable, a small percentage do fail. These failures usually result in minor or extensive system contamination depending on the severity of the failure. When an open type compressor becomes damaged internally, this provokes small particles of bearings, steel, brass, copper, and aluminum and, in severe cases, carbonized oil, which could contaminate the system. To prevent repeated failures, the problem which caused the failure should be corrected, and depending upon the severity of the failure, the system should be thoroughly cleaned out using one of the cleanout procedures mentioned.

#### 9.3.1 Determining Severity of Failure

The severity of compressor failure can be categorized as minor or major. A failure is considered minor when the contamination is limited to the compressor with little or no system contamination. A major failure, or burnout, results in extensive system contamination as well as compressor damage. Extensive system contamination can be determined by withdrawing a small sample of compressor oil and checking its color, odor and acidity. A Virginia Chemical "TKO" one step acid test kit is one of several compressor oil test kits that may be used. A high acid content would indicate a major failure or burnout. A small amount of refrigerant gas may be discharged. A characteristic burned odor would also indicate severe system contamination.

#### 9.3.2 Clean-out after Minor Compressor Failure

1. Be sure to correct the problem which caused the failure.
2. Change liquid line filter dryer.
3. Run the unit for 2 hours on high speed cool only.
4. Check compressor oil level to ensure compressor is not overcharged with oil.



## Section 22: HEATING AND AIR CONDITIONING

Sometimes a significant amount of oil is pumped out of the compressor to other parts of the system when a compressor fails. This oil will return to the replacement compressor when it is started, causing an overcharge of oil in the sump of the replacement compressor. In this case, it is important that the oil level be adjusted to the proper level.

5. Withdraw a sample of the compressor oil and check its color, odor, and acidity, using instructions supplied above. If the oil is contaminated, change the oil and filter dryer, and repeat the procedure until the system is clean.

### 9.3.3 Clean-out After Major Compressor Failure

1. Reclaim the refrigerant into a refrigerant bottle through a filter dryer to filter out contaminants.
2. Remove the failed compressor and repair it if possible.
3. Install new or repaired compressor.
4. Change the filter dryer.
5. Circulate clean R-134a with the reclaimer to clean out many of the contaminants collected in the coil valves, TXV (Thermal Expansion Valve), solenoid valves, check valves, and any other mechanical component that may have collected contaminants.
6. Evacuate and charge the system normally.
7. Run the unit for 8 hours and monitor the pressure drop across the filter dryer. Also check the liquid line dryer for signs of restriction. If the pressure drop across the filter dryer exceeds 12 to 14 psig (82,75 to 96,5 kPa) with a 40°F (5°C) evaporator coil temperature, stop the unit and change the liquid line and suction line filter dryer. After 4 or 5 hours of operation, stop the unit and replace the filter dryer.
8. After 8 hours of operation, stop the unit and remove a sample of the compressor oil and check its color, odor, and acidity, using instructions supplied above. If the oil is contaminated, replace the oil and repeat step 7. If the oil is not contaminated, change the

filter dryer again and replace the moisture-liquid indicator.

9. After approximately 7 days of operation, recheck the compressor oil for cleanliness and acidity.

### 9.4 PUMPING DOWN

This procedure is intended to reduce refrigerant loss by isolating it in the compressor and the receiver tank, as well as in their connecting line, in order to carry out repairs on other sections of the air conditioning system (lines and components).

**Note:** Before attempting any repair between compressor and receiver tank, use a recovery unit to remove refrigerant from the system.

**Warning:** When air conditioning system must be opened, refer to previous paragraph "Precautions In Handling Refrigerant" to prevent any injury.

#### Procedure

1. Energize passenger side liquid solenoid valve.
2. Run the system for 10 minutes, shut it OFF, then close the receiver tank outlet valve by turning it clockwise, backseat the suction service valve on the compressor, install an appropriate pressure gauge set, and turn the valve forward ¼ turn to enable a visual check of the suction pressure.
3. Disconnect the "Low Pressure Switch" connector (mounted near the A/C compressor, and install a jumper wire.

**Note:** This jumper wire will allow the clutch to remain engaged after pressure drops below 15 psi (103,5kPa).

4. Start the engine, press the "Passenger ON/OFF" switch then the A/C switch, adjust "A/C Temperature" control to maximum A/C.
5. Run the compressor until pressure reaches 1-2 psi (7-14 kPa).

## Section 22: HEATING AND AIR CONDITIONING

---

**Note:** *During this operation, care must be taken not to fill the receiver tank over the upper sight glass. If so, stop process immediately. Always allow refrigerant piping and units to warm up to the ambient air temperature before opening system or sweating will take place inside the lines.*

5. Stop engine, and close compressor outlet valve by turning it clockwise until valve is properly seated.
6. Close compressor suction valve by turning it clockwise until it is properly seated.
7. Wait until pressure gauge reaches 1 to 2 psi (7 to 14 kPa). To accelerate procedure, lightly open compressor suction valve until pressure reaches this value.

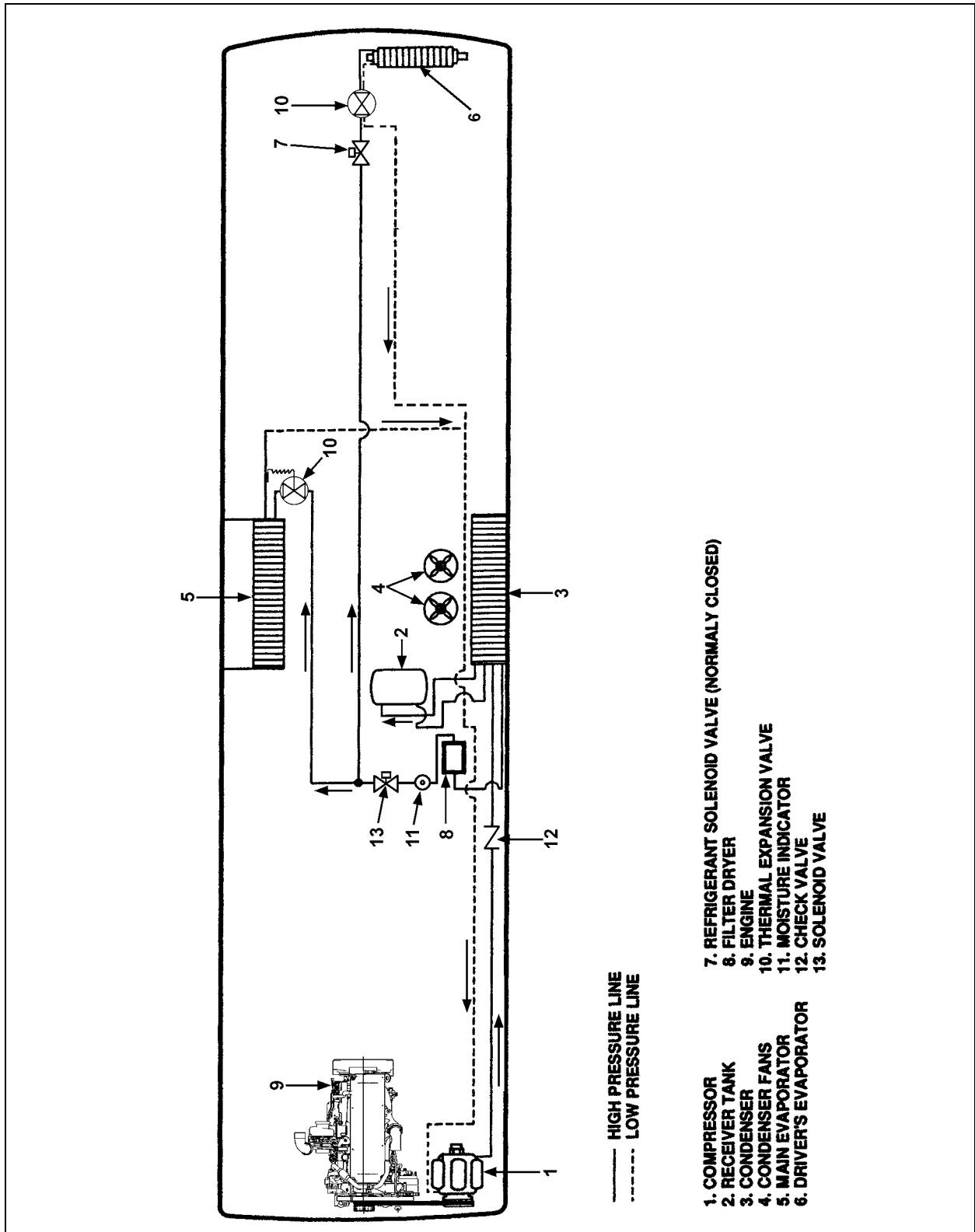

FIGURE 19: CENTRAL A/C SYSTEM COMPONENTS

22220

## Section 22: HEATING AND AIR CONDITIONING

---

### 9.5 ADDING REFRIGERANT (VAPOR STATE)

Use the suction service valve on the compressor to add a small quantity of refrigerant to the system. Backseat the valve and connect a charging line from the refrigerant cylinder to the valve. Tighten connection at level of refrigerant cylinder and open tank end slightly to purge air from the charging line. Tighten the charging line at the compressor. Screw in the stem of suction valve approximately two turns. Start the engine and run at fast idle. Add sufficient refrigerant to bring the level in lower sight glass of receiver tank to mid-point. Always charge the system with the cylinder upright and the valve on top to avoid drawing liquid out of the cylinder. Fill liquid refrigerant at the receiver tank and completely charge, if necessary, using previous procedure.

### 9.6 EVACUATING SYSTEM

1. Open both receiver valves by turning "out" (normal position).
2. Remove the caps from the two 90° adapters on the suction, discharge valves and connect two hoses to the vacuum.
3. Place the two compressor valves, suction and discharge, in neutral position by turning each one 3 to 4 turns "in" from the "out" position.
4. Open the solenoid valve by energizing or manually bypass.
5. Start the vacuum pump. Open the large (suction) shutoff valve and close the small vacuum gauge valve.
6. The pressure will drop to approximately 29 inches vacuum (14.2 psi or 97.9 kPa) (the dial gauge only gives a general idea of the absolute system pressure).
7. Backseat the compressor valves by turning "out" all the way.
8. Shut down the vacuum pump.
9. Remove the hoses.
10. Reinstall the caps at the suction valve take-off points.

### 9.6.1 Double Sweep Evacuation Procedure

1. Remove any remaining refrigerant from the system using a refrigerant recovery machine.
2. Connect the evacuation manifold, vacuum pump, hoses and micron gauge to the unit.
3. With the unit service valves closed (back seated) and the vacuum pump and the thermistor valves open, start the pump and draw the manifold and hoses into a very deep vacuum. Shut the vacuum pump off and see if the vacuum holds. This is to check the setup for leaks.
4. Midseat the system service valves.
5. Open the vacuum pump and the thermistor valves. Start the pump and evacuate to a system pressure of 2000 microns.
6. Close the vacuum pump and the thermistor valves, turn off the vacuum pump (closing the thermistor valve protect the valve from damage).
7. Break the vacuum with clean refrigerant (or dry nitrogen) and raise the pressure to approximately 2 PSIG. Monitor the pressure with the compound gauge.
8. Remove the refrigerant with the recovery machine.
9. Repeat steps #5 – 8 one time.
10. After the second "sweep", change the filter drier (if you have not done so) and evacuate to 500 microns.
11. Evacuating the system below 500 microns on systems using the Carrier 05G compressor may risk drawing air into the system past the carbon shaft seal.
12. Check to insure that vacuum holds. (If the pressure continues to rise, it indicates a leak or moisture in the system).
13. Charge the system with the proper amount of refrigerant using recommended charging procedures.

**Note:** *This method will aid in preventing unnecessary system failures by ensuring that the refrigeration system is free of contaminants.*

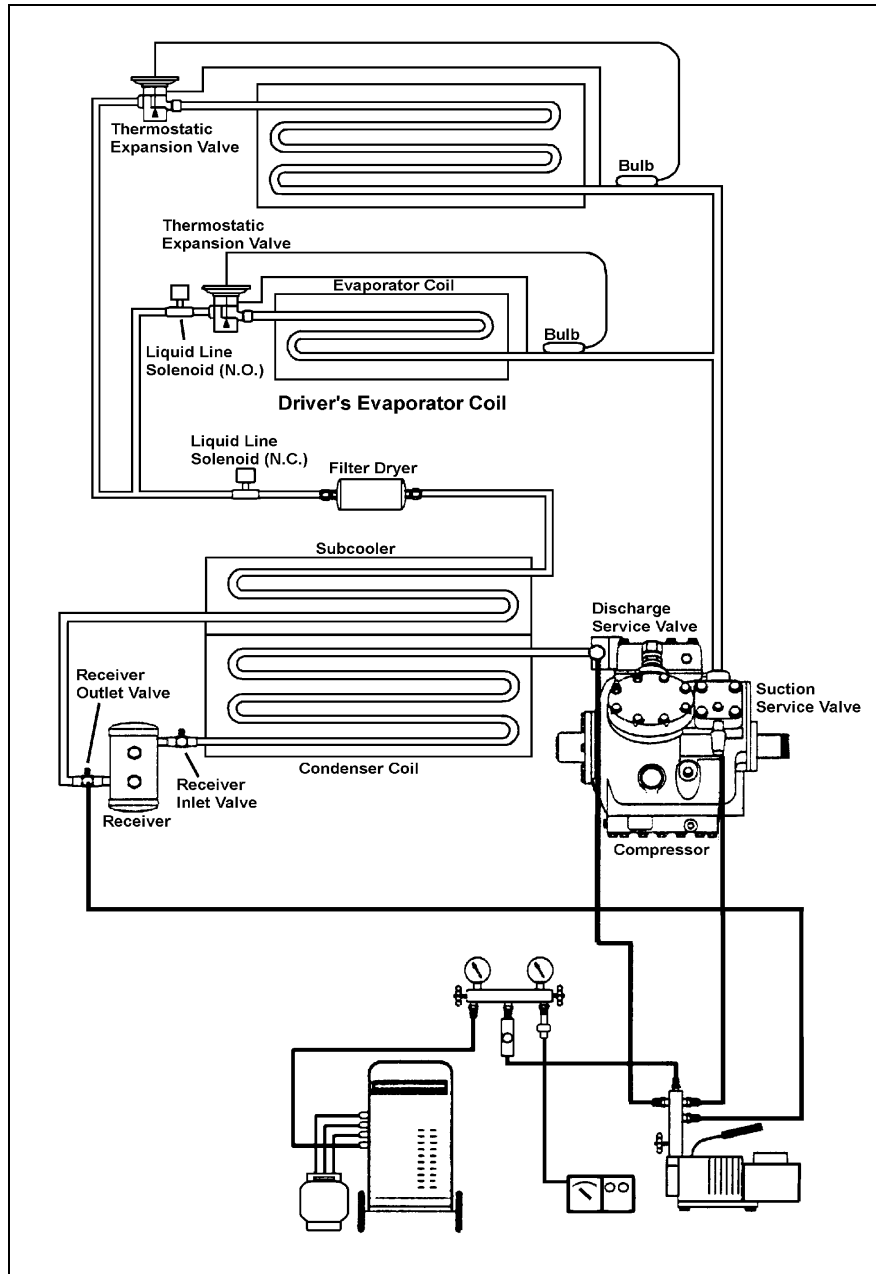

FIGURE 20: DOUBLE SWEEP EVACUATION SET-UP

### 9.7 CHARGING SYSTEM

When a system has been opened or if there are any questions about the air or moisture in the system, evacuate the system. Charging of an evacuated system may be accomplished by forcing liquid R-134a directly into the receiver tank.

When charging an empty system, weigh the amount of refrigerant put into the system. This

will eliminate any possibility of overfilling. A nominal charge requires 24 pounds (10,9 kg).

1. Backseat the two compressor shutoff valves ("out").
2. Install the test gauges at the shutoff valves noting that the 400 psi (2758 kPa) gauge is connected to the discharge.
3. Turn in the two shutoff valves 3 to 4 turns.

## Section 22: HEATING AND AIR CONDITIONING

4. Open the lower receiver valve by turning "out" all the way.
5. Backseat the upper receiver valve by turning out all the way.
6. Remove the cover cap from the service fitting in the top receiver valve.
7. Attach a charging hose to the R-134a tank. Open the tank valve slightly permitting R-134a to escape thus purging the hose of air.
8. Connect the charging hose to the service fitting.
9. Open the R-134a tank valve.
10. To build up pressure in the receiver tank, heat the receiver tank with a heating blanket.
11. Turn in the upper receiver valve several turns. The R-134a will now enter the system.
12. The proper charge of R-134a is 24 lbs (10.89 kg). When the scale indicates this amount of charge, backseat the receiver valve and close the R-134a tank valve.
13. Disconnect the charging hose. Replace the cover caps.
14. The system is now ready for operation.

**Caution:** The evacuation of the system must be made by authorized and qualified personnel only. Refer to local laws for R-134a recuperation.

### 10. CENTRAL A/C SYSTEM COMPONENTS

#### 10.1 COMPRESSOR (CENTRAL SYSTEM)

##### 10.1.1 Belt Replacement

**Warning:** Set the main battery disconnect switch to the "Off" position. For greater safety, set the engine starter selector switch in engine compartment to the "Off" position.

1. Open engine compartment rear doors and locate the belt tensioner two-way control valve (Fig. 20), mounted above the engine R.H. side door next to the pressure regulating valve, then turn handle

counterclockwise in order to release pressure and tension on belts.

2. Slip the old belts off and the new ones on.
3. Reset belt tensioning pressure control valve (Fig. 20). Pressure is factory set to 45 psi (310 kPa), periodically check proper pressure.

**Note:** Both belts must always be replaced simultaneously to ensure an equal distribution of load on each of them.

**Note:** For proper operation of the air bellows, adjust upper tensioning bracket to provide a ¼" (7 mm) gap between stopper and bracket under normal pressure of 45 psi - 310 kPa. (Fig. 21).

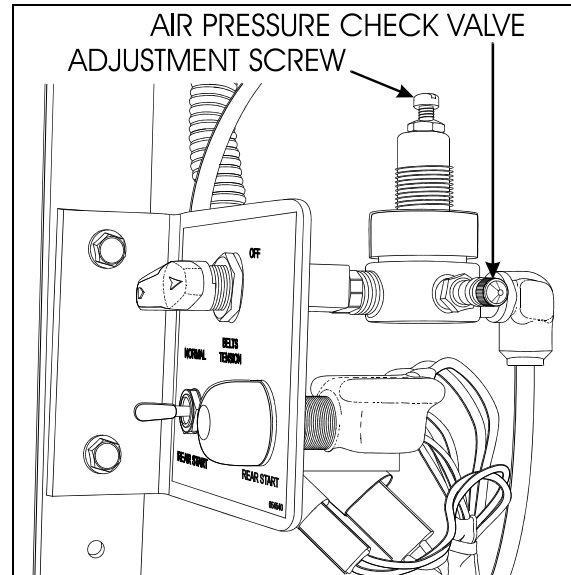

FIGURE 21: TENSIONING VALVE

01058

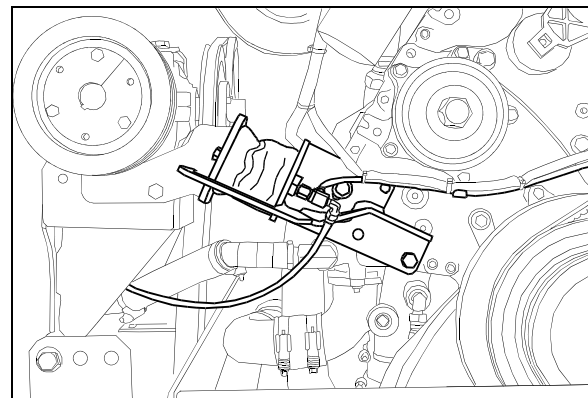

FIGURE 22: TENSIONING AIR BELLOWS

01059

## Section 22: HEATING AND AIR CONDITIONING

### 10.1.2 Pulley Alignment

In order to avoid skipping, disengagement and a premature wear of compressor belt, it is necessary to align compressor pulley with the crankshaft pulley. Before performing the following procedure, release air from belt tensioners by means of the two-way control valve. After completing these procedures reset belt tensioning pressure control valve to 45 psi (310 kPa).

### 10.1.3 Longitudinal Compressor Alignment

1. Rest an extremity of a straight edge of approximately 46 inches (117 cm) against the upper part of the outer face of crankshaft pulley, positioning the other end close to the compressor clutch pulley (Figs. 22 & 23).
2. Check the distance between each extremity of straight edge (1, Fig. 22) and the first drive belt. If they are different, loosen the compressor support bolts and with a hammer, knock support to slide it in order to obtain the same distance; then tighten bolts.

### 10.1.4 Horizontal Compressor Alignment

1. Rest an extremity of the straight edge against the upper part of the outer face of compressor pulley, positioning the other end close to the crankshaft pulley.
2. Check the distance between each extremity of straight edge (1, Fig. 22) and drive belt. If they are different, loosen the pillow block compressor bolts and with a hammer, knock compressor pillow block to slide it, in order to obtain the same distance; then tighten bolts.

### 10.1.5 Vertical Compressor Alignment

Rest a short "angle and level indicator" on the outer side face of the crankshaft pulley, adjust the level indicator inclination at  $0^\circ$  and check if the compressor pulley is at same angle (Figs. 22 & 23). If it is not the same, shim under the appropriate pillow block in order to obtain the correct angle.

### 10.1.6 Compressor Maintenance

For the maintenance of the A/C compressor, see the "Carrier Compressor Operation and Service Manual" included at the end of this section.

**Caution:** Use only Castrol SW 68 (POE) oils with refrigerant 134a.

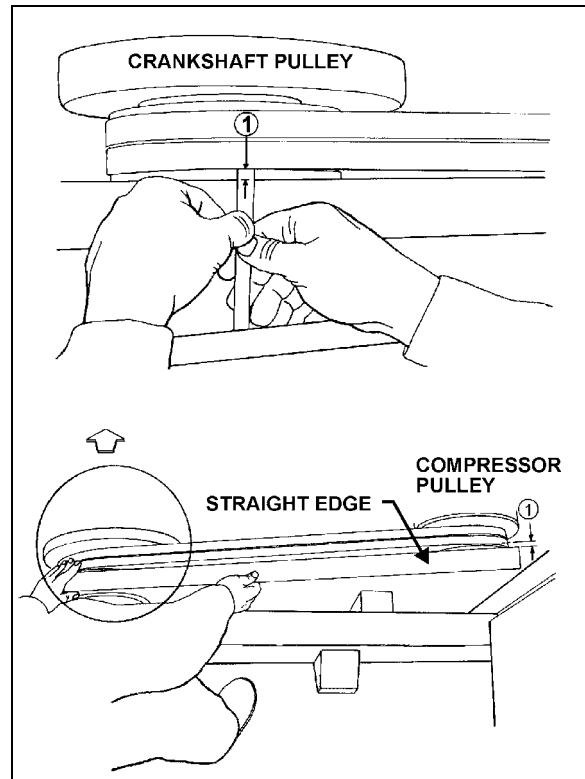

FIGURE 23: COMPRESSOR ALIGNMENT

22040

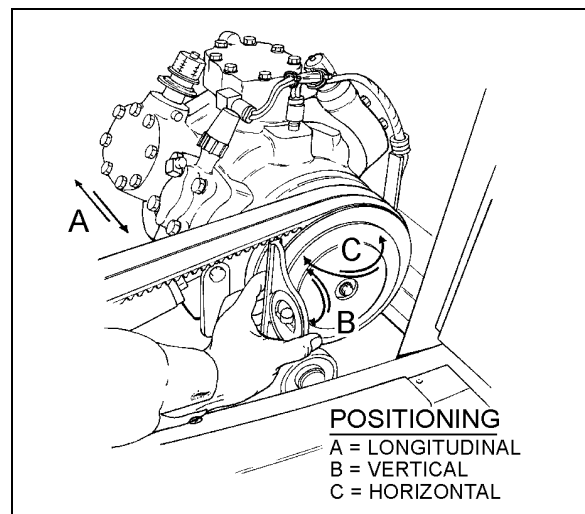

FIGURE 24: COMPRESSOR ALIGNMENT

22072

Section 22: HEATING AND AIR CONDITIONING

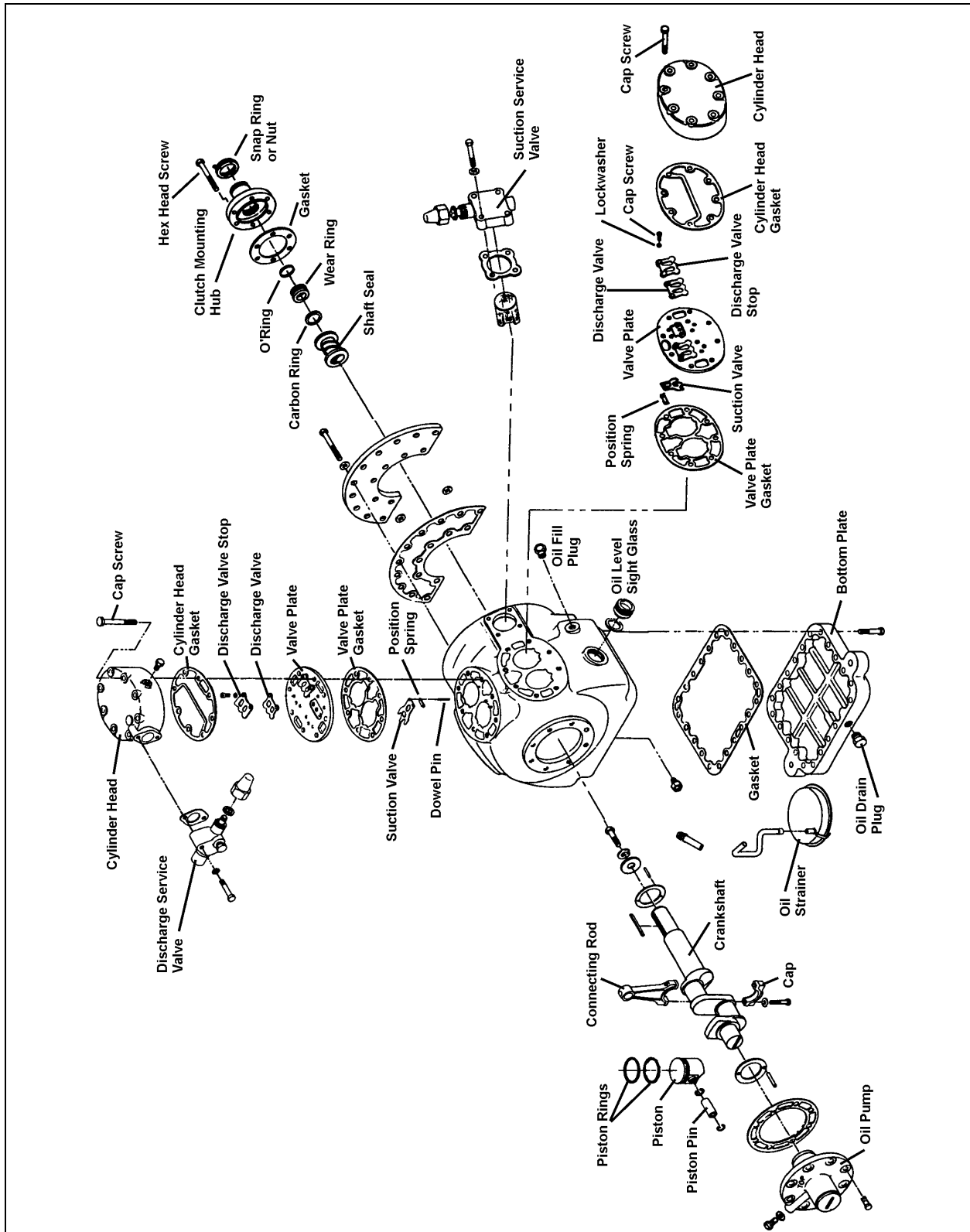

FIGURE 25: EXPLODED VIEW OF 05G COMPRESSOR

22214



**10.1.7 Troubleshooting Guide**

A preliminary check may be made by simply feeling the cylinder heads with the unit in operation at ambient temperatures of 35 °F (2°C) and over. The cylinder heads are internally divided into suction and discharge valves. The lower half of the cylinder head is the suction side, and it should be relatively cool to the touch, as opposed to the hot upper discharge side. If a valve plate or head gasket is blown, or a compressor unloader is stuck open, partially compressed refrigerant vapor will be circulated between the suction and discharge sides of the head. The affected cylinder head will then have a relatively even temperature across its surface and be neither as hot as the normal discharge temperature nor as cool as the normal suction temperature.

**Blown Head Gaskets**

Symptom:

- Loss of unit capacity at low temperature.
- Even cylinder head temperature.

Cause:

- Improperly torqued cylinder head bolts.
- Improperly positioned gasket at assembly.
- Warped cylinder head.
- Severe liquid refrigerant floodback.

**Blown Valve Plate Gaskets**

Symptom:

- Loss of unit capacity at medium and low temperatures.
- Very hot cylinder head surface.
- Higher than normal suction pressure.

Cause:

- Improperly torqued cylinder head bolts.
- Severe liquid refrigerant floodback.
- Oil slugging caused by an overcharge of oil or flood starts.
- Discharge valves not seated properly (liquid drainback during shutdown).

**Broken Suction Valves**

Symptom:

- Loss of unit capacity at all temperatures.
- Compressor unable to pull extremely low vacuum with suction service valve frontseated.

Cause:

- Repeated liquid refrigerant floodback.
- Flooded starts.
- Overcharge of oil.
- Discharge valves not seated properly (liquid drainback during shutdown).
- Expansion valve not controlling properly.

**Unloader Valve Stuck Open**

Symptom:

- Loss of unit capacity at all temperatures.
- Higher than normal suction pressure.
- Even cylinder head temperature.



Cause:

- Unloader body stem bent.
- Foreign material binding unloader piston or plunger.

**10.2 MAGNETIC CLUTCH**

Refer to Carrier service information entitled "Housing-Mounted Electric Clutch" at the end of this section for the description and maintenance of the magnetic clutch.

**10.2.1 HVAC Control Unit and Clutch Operation**

When A/C system is actuated using  switch, the corresponding switch LED will turn on, the A/C ON indicator LED  will turn on and the clutch will engage.

## Section 22: HEATING AND AIR CONDITIONING

**Note:** If the outside temperature is inferior to 25°F (-4°C), the A/C ON indicator LED  will turn off and the clutch will disengage. The indicator LED will turn back on and the clutch will reengage when the outside temperature reaches 35°F (2°C).

The A/C ON indicator LED  will also turn off and the clutch will disengage if a low (5 – 30 psi) or a high pressure (350 – 245 psi) condition is present.

**Note:** You must first enter the Troubleshooting Mode to be able to visualize on the telltale panel the low or high pressure condition (refer to paragraph 7.1).

**Note:** The indicator LED will turn back on and the clutch will reengage 45 seconds after the low or high pressure condition was corrected.

### 10.3 CONDENSER

The central A/C system condenser coil is hinge mounted on the R.H. side of the vehicle on the A/C condenser door. Since condenser's purpose is to dissipate heat from the hot refrigerant, it is important to keep the cooling coils and fins clean. A clogged coil will cause high discharge pressure and insufficient cooling.

#### 10.3.1 Condenser Fan Motors

Two axial fan motors are installed in condenser compartment on R.H. side of vehicle in order to ventilate the condenser coil. The fans pull outside air through the condenser coil and discharge it through an opening at bottom of compartment. Depending on pressure in receiver tank (Fig. 25), the fan motors may be operated at full rpm, half rpm or not operated at all. With low pressure in receiver tank, both fan motors are connected in series and then operate at half rpm and, with a high pressure in receiver tank, both fan motors are connected in parallel and operate at full rpm. For details about electrical wiring, refer to "A/C and Heat system" in the master wiring diagram.

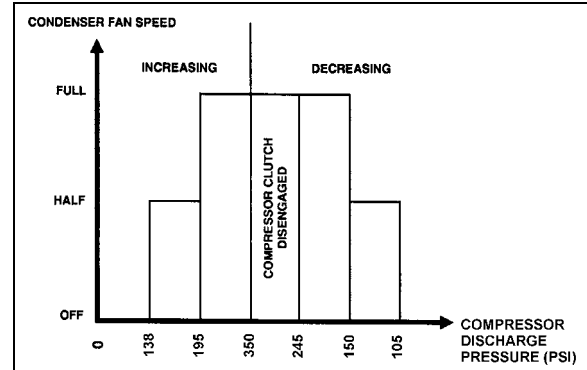

FIGURE 26: CONDENSER FAN SPEED IN RELATION WITH HIGH SIDE PRESSURE 22041

#### 10.3.2 Condenser Fan Motor Removal

1. Set the main battery disconnect switch to the "Off" position.
2. Remove the two "Phillips" head screws retaining the fan motor protective cover to the square tubing.

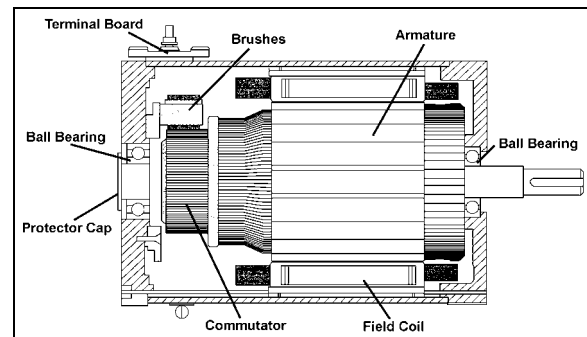

FIGURE 27: CONDENSER FAN MOTOR 22234

3. Disconnect wiring from terminals on motor. Tag each wire to aid in identification at time of reconnection.
4. Support motor, and remove bolts which attach motor to mounting bracket. Remove the motor.

#### 10.3.3 Preliminary Disassembly

1. Remove the brushes.
2. Unscrew the flange retaining screws on the shaft end side (opposite to the commutator end frame), and separate flange from frame (Fig. 26).

## Section 22: HEATING AND AIR CONDITIONING

3. Remove flange and rotor assembly by pushing bearing shaft toward the commutator end frame.
4. Separate flange from rotor.

### 10.3.4 Disassembly

1. Perform preliminary disassembly.
2. Carefully note the position of the brush holder ring and the connections on the flange support.
3. Unscrew and remove the flange on the commutator end frame.
4. Remove the brush holder ring.
5. Finally, separate the following parts: brush holders, brush boxes, terminal board, bearings, etc.

### 10.4 RECEIVER TANK

The receiver tank is located in the A/C condenser compartment (Fig. 27). The function of the receiver tank is to store the liquid refrigerant. During normal operation, the level of the refrigerant should be approximately at the mid-point of the lower sight glass.

In case of extreme pressure there will be a rise in the liquid receiver tank. A pressure relief valve will break at 450 psi (3103 kPa) and relieve the receiver tank pressure.

The receiver tank incorporates an inlet valve on the inlet side (upper section) which allows the tank to be isolated or serviced. An outlet valve on the outlet side (lower section) permits complete isolation from the rest of the system.

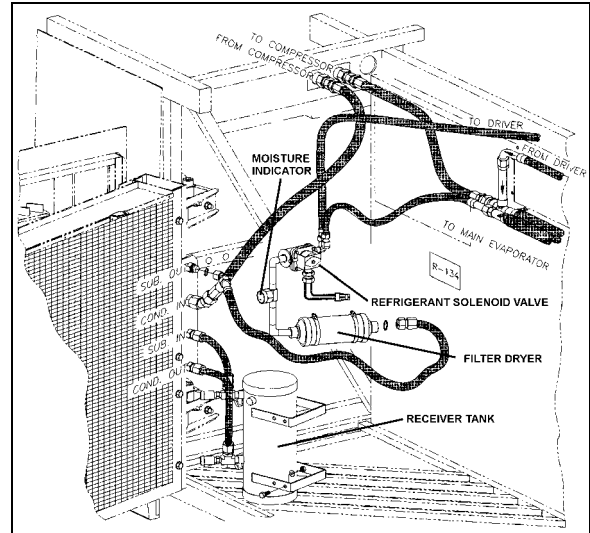

FIGURE 28: A/C CONDENSER COMPARTMENT 22219

### 10.5 FILTER DRYER

A filter dryer, also located in the A/C condenser compartment, is installed on the liquid refrigerant line (near the receiver tank). It is used to absorb moisture and foreign matter from refrigerant before it reaches the expansion valves.

The filter should be replaced if the system has been opened to prolonged exposure as shown by the moisture indicator sight glass.

A filter dryer, located in the engine compartment near the radiator is installed on vehicles equipped with a driver's system only. Its function is similar to that of filter used on main systems. Replace only when system is opened or a problem occurs.

#### 10.5.1 Replacement

The filter is of the disposable type. When replacement is required, remove and discard the complete unit and replace with a new unit of the same type according to this procedure:

1. Isolate the refrigerant in the receiver tank by following the "Pumping Down" procedure explained in this section
2. Change the filter dryer as a unit.
3. Add a small quantity of refrigerant R-134a to the low side of the system. Check for leaks. Return the system to normal operation.

## Section 22: HEATING AND AIR CONDITIONING

**Caution:** Do not use carbon tetrachloride or similar solvents to clean parts. Do not use steam guns. Use mineral spirits or naphtha. All parts should be thoroughly cleaned. Use a stiff brush to wash dirt from grooves, holes, etc.

**Warning:** Cleaning products are flammable and may explode under certain conditions. Always handle in a well ventilated area.

### 10.5.2 Moisture Indicator

The moisture sensitive element consists of a color changing ring which is reversible from yellow to green and vice versa as the moisture content in the refrigerant changes. Yellow indicates a wet refrigerant, yellow green (caution) and green indicates a dry refrigerant.

Since temperature changes affect the solubility, color change will also vary with the refrigerant temperature. The following table shows the color change for R-134a at various moisture levels and liquid line refrigerant temperatures.

COLOR INDICATOR			
Temperature	BLUE (ppm)	LIGHT VIOLET (ppm)	PINK (ppm)
75°F (24°C)	Below 5	5-15	Above 15
100°F (38°C)	Below 10	10-30	Above 30
125°F (52°C)	Below 15	15-45	Above 45

p.p.m.= parts per million (moisture content)

A moisture level of less than 15 p.p.m. for R-134a indicated in the blue color range of the above table is generally considered dry and safe. A color indication of light blue to light violet indicates the caution range of moisture level. For positive protection, the drying of the system should be continued until the color of the element turns to deep blue.

The liquid refrigerant is readily visible through the center opening of the moisture element where the presence of bubbles indicates a shortage of refrigerant or restriction in line.

Moisture is one of the main causes of chemical instability or contamination in air conditioning systems. If moisture is present, it can corrode the valves, condenser and evaporator coils, compressor and other components causing a malfunction and eventually failure of the system.

Uncontrolled moisture in the system can result in expensive multiple component replacements if not corrected at an early stage. The moisture indicator permits an early detection of moisture in the system and when corrected by a desiccant charge, system contamination is greatly minimized.

### 10.6 LIQUID REFRIGERANT SOLENOID VALVE

The flow of liquid refrigerant to both driver's and central evaporators is controlled by a normally-closed solenoid valve. The driver's solenoid valve is located on the ceiling of the spare wheel compartment and is accessible through the reclining bumper while the central system solenoid valve is located in the condenser compartment.

#### 10.6.1 Manual Bypass

This type of solenoid valve is equipped with a manual operating stem. The 3/16" square stem located on the bonnet is exposed when the seal cap is removed. To manually open valve, turn stem ½ turn counterclockwise. To manually close valve, turn stem clockwise until tight against seat. Manual stem must be in closed position for automatic electrical operation.

#### 10.6.2 Coil Replacement

1. Disconnect connector from the coil connector.
2. Take out the retaining screw at the top of the coil housing. The entire coil assembly can then be lifted off the enclosing tube.
3. Place the new coil and yoke assembly on the enclosing tube. Lay data identification plate in place.
4. Insert the coil retaining screw, rotate housing to proper position and tighten screw securely.
5. Connect connector from coil connector.

#### 10.6.3 Valve Disassembly

1. Remove the coil as stated previously.
2. Pump down the system as stated earlier in this section.

## Section 22: HEATING AND AIR CONDITIONING

3. Remove the four socket head screws which hold the body and bonnet together (Fig. 28).
4. Carefully lift off the bonnet assembly (upper part of the valve) so that plunger will not fall out. The diaphragm can now be lifted out.

**Note:** The previous procedure must be followed before brazing solder-type bodies into the line.

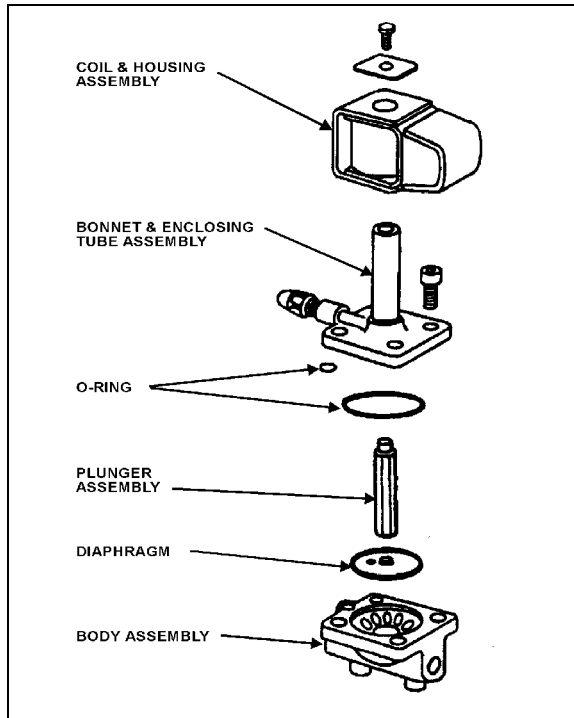

FIGURE 29: REFRIGERANT SOLENOID VALVE 22044

**Caution:** Be careful not to damage the machined faces while the valve is apart.

### 10.6.4 Valve Reassembly

1. Place the diaphragm in the body with the pilot port extension up.
2. Hold the plunger with the synthetic seat against the pilot port.
3. Make sure the bonnet O-rings are in place. Lower the bonnet assembly over the plunger, making sure that the locating sleeve in the bonnet enters the mating hole in the body.
4. Insert the four socket head screws and tighten evenly.
5. Replace the coil as stated previously.

6. Add a small quantity of refrigerant R-134a to the low side of the system. Check for leaks. Return the system to normal operation.

## 10.7 EXPANSION VALVE

### 10.7.1 Central system

The expansion valve for the main system is a thermo-sensitive valve with a remote control bulb head attached to the evaporator outlet line and is accessible by the evaporator filter access door (Fig. 18 & 29). The valve regulates the flow of refrigerant liquid into the evaporator coils and is controlled by the suction gas temperature leaving the evaporator. The bulb head senses the refrigerant gas temperature as it leaves the evaporator. High temperature will cause expansion and pressure on the power head and spring. Such action causes the assembly valve to open, allowing a flow of refrigerant liquid into the evaporator.

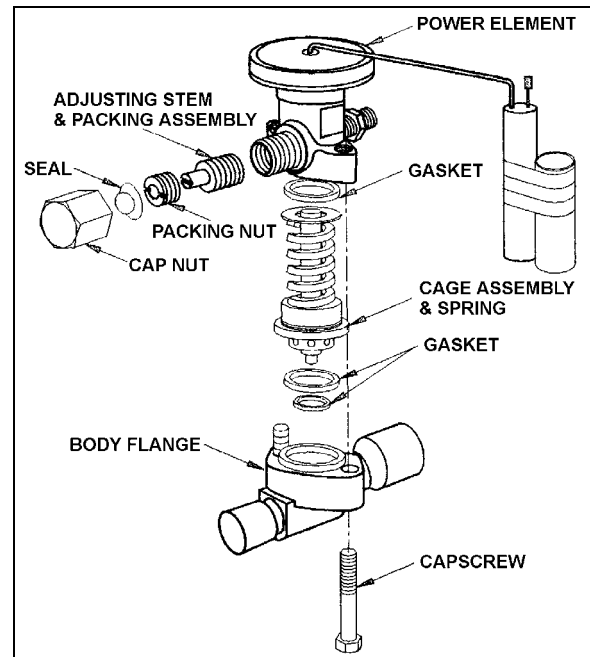

FIGURE 30: EXPANSION VALVE 22215

The remote bulb and power assembly is a closed system. The pressure within the remote bulb and power assembly corresponds to the saturation pressure of the refrigerant temperature leaving the evaporator and moves the valve pin in the opening direction. Opposed to this force, on the under side of the diaphragm and acting in the closing direction, is the force

## Section 22: HEATING AND AIR CONDITIONING

exerted by the superheat spring. As the temperature of the refrigerant gas at the evaporator outlet increases above the saturation temperature corresponding to the evaporator pressure, it becomes superheated. The pressure thus generated in the remote bulb and power assembly surpasses the combined pressures of the evaporator pressure and the superheat spring, causing the valve pin to move in the opening direction. Conversely, as the temperature of the **refrigerant** gas leaving the evaporator decreases, the pressure in the remote bulb and power assembly also decreases and the combined evaporator and spring pressures cause the valve pin to move in the closing position.

As the operating superheat is raised, the evaporator capacity decreases, since more of the evaporator surface is required to produce the superheat necessary to open the valve. It is obvious, then, that it is most important to adjust the operating superheat correctly and that a minimum change in superheat to move the valve pin to full open position, is of vital importance because it provides savings in both initial evaporator cost of operation. Accurate and sensitive control of the refrigerant liquid flowing to the evaporator is necessary to provide maximum evaporator capacity under load conditions. The spring is adjusted to give 12 to 16° F (-11.1 to -8.8 ° C) of superheat at the evaporator outlet. This ensures that the refrigerant leaving the evaporator is in a completely gaseous state when drawn into the suction side of the compressor. Liquid would damage the compressor valve, piston and heads if allowed to return in the suction line.

A vapor is said to be superheated when its temperature is higher than the saturation temperature corresponding to its pressure. The amount of the superheat is, of course, the temperature increase above the saturation temperature at the existing pressure.

As the refrigerant moves along in the evaporator, the liquid boils off into a vapor and the amount of liquid decreases until all the liquid has evaporated due to the absorption of a quantity of heat from the surrounding atmosphere equal to the latent heat of vaporization of the refrigerant. The gas continues along in the evaporator and remains at the same pressure. However, its temperature

increases due to the continued absorption of heat from the surrounding atmosphere. The degree to which the gas refrigerant is superheated is related to the amount of refrigerant being fed to the evaporator and the load to which the evaporator is exposed.

### Superheat Adjustment

The easiest method of adjusting the superheat is to unscrew completely the main evaporator expansion valve adjusting screw, and screw in 13 turns clockwise for 134A (Fig. 30). If this method does not provide an accurate superheat, the following procedure should be followed:

1. Operate coach for at least one-half hour at fast idle with temperature control set at 82°F (27,7°C), Then set temperature to minimum to keep the compressor on 6 cylinders.

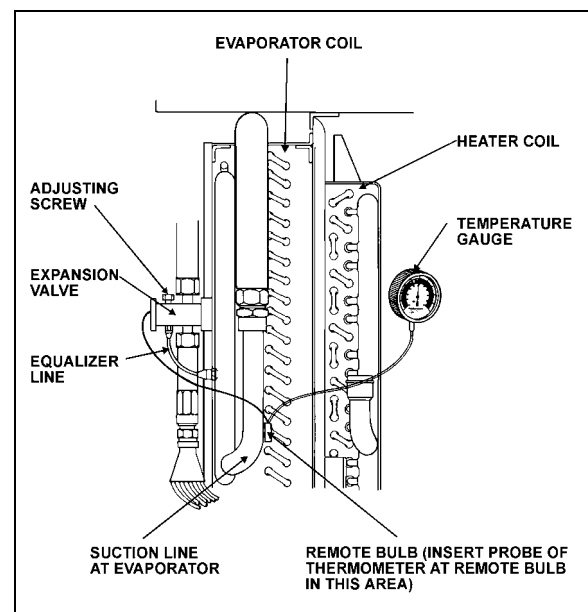

FIGURE 31: SUPERHEAT ADJUST. INSTALLATION 22046

2. Install pressure gauge at the evaporator suction header. You may install the pressure gauge at compressor suction, but then add 3 psi to reading.
3. Install a remote reading thermometer to the evaporator outlet line near the existing remote bulb (Fig. 30).
4. Apply thermostatic tape around the bulb and evaporator outlet line to get a true reading of the line temperature.

5. Block condenser if necessary to keep pressure over 150 psi.
6. Check approximately 5 readings of pressure at 2-minute intervals and convert to temperature using the vapor-pressure table (page 35). Likewise check the temperature reading at the remote bulb at the same 2-minute intervals and record the low and high swing readings of the needle (refer to Fig. 31).

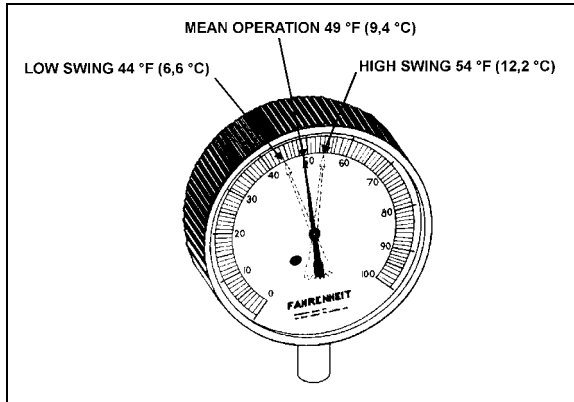

FIGURE 32: HIGH & LOW SWING TEMPERATURE AT REMOTE BULB 22047

Example of readings taken at fig. 31:

A/C pressure gauge converted to temperature at expansion valve fitting	Temperature on remote bulb	
40°F(4,4°C)	Low-swing 44°F (6,6°C)	High swing 54°F (12,2°C)
Formula for superheat 49°F-40°F=9°F (9,4°C-4,4°C = 5°C)	Average of low and high swing is 49°F (9,4°C)	

**Note:** The low swing of the superheat should be a minimum of 4°F (2,2°C) higher at the remote bulb and have an average of 8 to 12°F (4 to 6°C) higher range at the bulb than the fitting at the expansion valve.

**Note:** To reduce the superheat, flow of refrigerant is increased by turning adjusting screw of expansion valve lower evaporator temperature counterclockwise. To increase temperature or increase superheat, flow of refrigerant is reduced by turning adjustment screw of expansion valve clockwise.

6. Regulate suction pressure to temperature reading according to temperature chart or to the R-134a temperature scale on the pressure gauge.

**Example:** Suction pressure 30 psi (207 kPa) converted to 32°F (0°C) on chart. If temperature reading is 40°F (4,4°C), subtract 32°F (0°C) and the result will be 8°F (4,4°C) of superheat.

**Caution:** Before proceeding with the expansion valve adjustment, check for restriction on suction side for plugged filter dryer and partially open valves. These conditions will give a high superheat.

### Maintenance

1. Pump down the system as previously indicated in this section.
2. Disconnect the external equalizer line from the under side of the power head, and unclamp the remote control bulb from the evaporator coil outlet line.
3. Remove the two cap screws holding the power assembly to the valve body flange. Lift off the power assembly and remove the cage assembly.
4. When reassembling, replace with the new gaskets in proper location. Make sure the two lugs on the cage assembly fit into grooves provided in the power assembly. Do not force the valves together. The cage must fit properly before tightening the body flange. Tighten bolts evenly.
5. Check for leaks.

### Safety Instructions

1. Make sure the valve is installed with the flow arrow on the valve body corresponding to the flow direction through the piping system.
2. Before opening any system, make sure the pressure in the system is brought to and remains at the atmospheric pressure.

## Section 22: HEATING AND AIR CONDITIONING

---

Failure to comply may result in system damage and/or personal injury.

### 10.7.2 Driver's System

The function and operation of the expansion valve for the driver's system are similar to the central system, but no superheat adjustment is required (see Fig. 38).

### 10.8 TORCH BRAZING

Use an electrode containing 35% silver.

**Note:** A 3.5% silver low temperature brazing electrode can be used on low side pressure and liquid high side.

**Caution:** When using heat near a valve, wrap with a water saturated rag to prevent overheating of vital parts.

**Warning:** Before welding any part of refrigeration system, make sure the area is well ventilated.



10.9 TROUBLESHOOTING

10.9.1 Expansion Valve

PROBABLE CAUSE	PROBABLE REMEDY
<b>LOW SUCTION PRESSURE-HIGH SUPERHEAT</b>	
EXPANSION VALVE LIMITING FLOW:	
Gas in liquid line due to pressure drop in the line or insufficient refrigerant charge.	Locate cause of line flash and correct by use of any of the following methods. Add R-134a. Replace or clean filter dryer.
Inlet pressure too low from excessive low condensing temperature. Resulting pressure difference across valve too small.	Increase head pressure. Verify pressure switch for fan speed control.
Superheat adjustment too high.	Adjust superheat as outlined under "Superheat Adjustment".
Power assembly failure or partial loss of charge.	Replace power assembly or replace valve.
Air filter screen clogged.	Clean or replace air filter screen.
Plugged lines.	Clean, repair or replace lines.
<b>LOW SUCTION PRESSURE-LOW SUPERHEAT</b>	
Uneven or inadequate evaporator loading due to poor air distribution or liquid flow.	Balance evaporator load distribution by providing correct air or liquid distribution.
<b>HIGH SUCTION PRESSURE-HIGH SUPERHEAT</b>	
Compressor discharge valve leaking.	Replace or repair valve.
<b>HIGH SUCTION PRESSURE-LOW SUPERHEAT (DEFECTIVE UNLOADER)</b>	
Valve superheat setting too low.	Adjust superheat as outlined under "Superheat Adjustment".
Compressor discharge valves leaking.	Replace or repair discharge valve.
Incorrect superheat adjustment.	Superheat adjustment 12 to 16°F.
<b>FLUCTUATING DISCHARGE PRESSURE</b>	
Insufficient charge.	Add R-134a to system.
<b>HIGH DISCHARGE PRESSURE</b>	

## Section 22: HEATING AND AIR CONDITIONING

PROBABLE CAUSE	PROBABLE REMEDY
Air or non-condensable gases in condenser.	Purge and recharge system.
Overcharge or refrigerant.	Bleed to proper charge.
Condenser dirty.	Clean condenser.

### 10.9.2 A/C

TROUBLE	CAUSE
Low suction pressure and frosting at dryer outlet.	Clogged filter.
Low Oil Level.	Check for oil leaks and for leaking oil seal. Do not attempt to check oil level unless system has been stabilized at least 20 minutes. See oil level verification.
Excessively cold suction line.	Loss of contact between the expansion valve bulb and the suction line or sticking of the expansion valve.  Check for foreign matter and clean, repair or replace the valve.
Excessively cold suction line and noisy compressor.	Check superheat adjustment. Check remote bulb contact. Check expansion valve for sticking.
Compressor squeaks or squeals when running.	Check oil level. Replace oil seal.
Noisy or knocking compressor.	Check for broken internal parts. Overhaul if required.
Compressor vibrates.	Check and tighten compressor mounting bolts and belt tension.
Low refrigerant level	Check for refrigerant leaks and add refrigerant if required.
Suction pressure rises faster than 5 pounds per minute after shutdown.	Check compressor valve for breakage or damage.
Insufficient cooling.	Check for refrigerant leaks. Check condition of air filter and motors.
Insufficient air flow.	Dirty or iced evaporator. Dirty air filter. Blowers inactive. Clogged ducts.
No flow of refrigerant through expansion valve.	Filter dryer is clogged. Remote bulb has lost charge or expansion valve is defective.
Expansion valve hisses. Bubbles in moisture and liquid indicator.	Gas in liquid line. Add refrigerant.
Loss of capacity  Superheat too high.	Clogged filter. Obstructed or defective expansion valve.  Reset superheat adjustment. Check for clogged external equalizer line, or filter dryer.
Reduced air flow: a. Dirty or clogged air filter; b. Evaporator motor inoperative; or c. Plugged return air ducts.	Dirty or iced evaporator coil. Clean air filter screen. Check return ducts for obstructions. Check blower motor.
Frequent startings and stoppings on low pressure	Lack of refrigerant. Check for leaks. Recharge.

**Section 22: HEATING AND AIR CONDITIONING**

<b>TROUBLE</b>	<b>CAUSE</b>
control switch.	
Compressor intermittently starts and stops.	Intermittent contact in electrical control circuit. Compressor valves not in operating position.
Non-condensable in the refrigeration system.	<p>Leak on system, system in vacuum in low temp. Specific symptom, pressure in system will not correspond to ambient temperature on shutdown. Only non-condensable will cause this.</p> <p>(Example: Pressure of idle R-134a system in 80°F (26.6°C) room should be 86.4 psi (595.7 kPa). See temperature chart in this section.)</p> <p>An evaporator just does a proper cooling job without sufficient air. Shortage of air can be caused by the following:</p> <ul style="list-style-type: none"> <li>• Dirty filters; or</li> <li>• Dirty coils.</li> </ul>
<p>Testing condenser pressure.</p> <p>Note: R-134A pressure is function of the temperature variation.</p> <p>Example, for an exterior temperature of 100°F. Exterior temperature (100°F) + 30°F = 130°F. Refer to paragraph "10.11 Temperature &amp; Pressure". Note the corresponding pressure for a temperature of 130°F., 199.8 psi. Read the condenser pressure, example 171.9 psi. 171.9 psi 199.8 psi, the pressure in the condenser is inferior to the pressure corresponding to the exterior temperature, then condenser pressure may be to low. Check for refrigerant leaks and add refrigerant if necessary. If the pressure corresponding to the condenser temperature is superior to the pressure corresponding to the exterior temperature, then air cooled condenser pressure may be to high. Most frequent causes are:</p> <p>Reduced air quantity. This may be due to:</p> <ul style="list-style-type: none"> <li>• Non-condensable in system;</li> <li>• Dirt on the coil;</li> <li>• Restricted air inlet or outlet;</li> <li>• Dirty fan blades;</li> <li>• Incorrect rotation of fan;</li> <li>• Fan speed too low;</li> <li>• Fan motor going out on overload; or</li> <li>• Prevailing winds.</li> <li>• Too much refrigerant in system. Remove refrigerant if necessary.</li> </ul>	

**Section 22: HEATING AND AIR CONDITIONING**

## 10.10 TEMPERATURES &amp; PRESSURES

VAPOR-PRESSURE			
TEMPERATURE		PRESSURE	
°F	°C	psi	kPa
-100	-73.3	27.8	191.7
-90	-67.8	26.9	185.5
-80	-62.2	25.6	176.5
-70	-56.7	23.8	164.1
-60	-51.1	21.5	148.2
-50	-45.6	18.5	127.6
-40	-40.0	14.7	101.4
-30	-34.4	9.8	67.6
-20	-29	3.8	26.2
-10	-23	1.8	12.4
0	-18	6.3	43.4
10	-12	11.6	80
20	-7	18.0	124.1
30	-1	25.6	176.5
40	4	34.5	237.9
50	10	44.9	309.6
60	16	56.9	392.3
70	21.1	70.7	487.5
80	27	86.4	595.7
90	32.2	104.2	718.5
100	38	124.3	857.0
110	43.3	146.8	1012.2
120	49	171.9	1185.3
130	54.4	199.8	1377.6
140	60	230.5	1589.3
150	65.6	264.4	1823.0
160	71	301.5	2078.8
170	76.7	342.0	2358.1
180	82.2	385.9	2660.8
190	87.8	433.6	2989.7

VAPOR-PRESSURE			
TEMPERATURE		PRESSURE	
°F	°C	psi	kPa
200	93.3	485.0	3344.1
210	98.9	540.3	3725.4

10.11 LEAK TESTING

Some methods such as nitrogen pressure and soap, and electronic sniffer can be used for leak testing. However, the most common method used is a "Halide" torch consisting of an acetylene tank, a burner and a suction test hose. Proceed as follows:

**Warning:** Do not inhale fumes from leak detector.

The flow of acetylene to the burner causes a suction in the test line. Any gas refrigerant present will be drawn through the hose and into the burner where it decomposes into free acids.

These acids come in contact with the hot copper reaction plate in the burner, causing color reaction in the flame. A small concentration is indicated by a green tint and a large concentration by an intense blue. Do not confuse this change in color with the change caused by shutting off the air supply through the hose by holding the end too close to an object.

The procedure for testing is:

1. Adjust flame so that the top of the cone is approximately level or within one-half inch above the plate.
2. Probe end of suction test tube around all joints, valves, etc. When a leak has been found at a soldered joint, that section of the system must be pumped down. Do not solder as pressure will force hot solder out. If the system is empty, it is more economical to put in just enough R-134a to produce about 15 psi (103 kPa). The pressure can be raised to about 150 psi (1034 kPa) with dry nitrogen.

**Note:** This gas is put into the suction and discharge shutoff valves at the compressor. The receiver valves must be opened. If no leaks are found, dump this mixture, evacuate the system and fill with refrigerant.

11. VIP DRIVER'S AIR CONDITIONING SYSTEM AND COMPONENTS

11.1 COMPRESSOR

MODEL	TM-16HD
TYPE	Swash-plate type
Number of cylinders	6
Bore	36 mm (1.42")
Stroke	26.7 mm (1.05")
Displacement	163 cm <sup>3</sup> (10cu.in)
Permissible speed	700-6000 rpm
Refrigerant	HFC-134a
Lubricant	ZXL100PG
	180 cm <sup>3</sup>
Mass	4.9 kg (10.9 lbs)

11.2 MAGNETIC CLUTCH

TYPE	Electromagnetic single-plate dry clutch
Rated Voltage	24/12 volts DC
Current consumption	3.75 amperes (max)
Stalling torque	49 Nm (36.1 Ft-Lbs) min
Rotation	CW/CCW
Mass	2.2 kg (4.9 lbs)

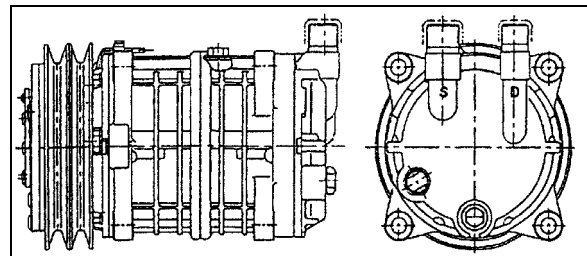

## Section 22: HEATING AND AIR CONDITIONING

---

FIGURE 33: SELTEC TM-16HD COMPRESSOR

### 11.3 MAINTENANCE PRECAUTIONS

#### 11.3.1 Work Area

Because the components of air conditioning systems are especially sensitive to moisture, dirt and dust, always observe the following procedures:

- Work indoors whenever possible.
- Select a level work area.
- Keep work area clean.
- Select a work area with adequate ventilation.

**Warning:** *Refrigerant itself is not harmful, but excessive accumulation in a closed area can cause oxygen deficiency.*

- Keep open flame and flammables away from the vehicle in which the air conditioning system is being serviced. **Open flame is especially dangerous during Freon leak testing.**

**Warning:** *Contact with flame and high temperatures can generate toxic gases.*

#### 11.3.2 Refrigerant Handling

Never directly heat refrigerant cylinder or put in hot water heated above 40°C (104°F) since it may cause release of the safety plug or the cylinder may burst. When it is necessary to heat refrigerant cylinder for charging in cold weather, use warm water at a temperature below 40°C (104°F).

**Warning:** *Do not put the charge valve in warm water.*

- Never store refrigerant cylinder in direct sunlight, near flame, or where the temperature exceeds 40°C (104°F). Always store refrigerant cylinder in a cool dry place.
- Never throw or strike refrigerant cylinder and never handle roughly.

#### 11.3.3 PAG Oil Handling

Whenever a part replacement has to be done on the system, additional task about PAG oil will have to be performed.

The compressor has little reserve and is lubricated by the oil refrigerant mixture. To perform correctly, the compressor needs the mixture to be from 3% to 6% of Poly Alkaline Glycol (PAG) oil.

When a compressor has to be top off due to a severe loss, the amount of oil to be added should be evaluated with the refrigerant charge or a compressor oil change should be performed to rise up the compressor oil charge to 180 ml or the written charge on the nameplate.

- The oil should be free from moisture, dust, metal shavings, etc.
- Do not mix with other oils.
- The moisture content of the oil increases when exposed to the air for prolonged period. Therefore, after use, seal the container immediately.

**DO NOT MIX PAG AND POE OR MINERAL OILS!**

#### 11.3.4 Refrigerant Recovery

Some air conditioning system refrigerant compounds are chlorofluorocarbons, and therefore may be damaging the earth's ozone layer. Consequently, the release of refrigerant into the atmosphere must be avoided. Whenever refrigerant is to be released from the air conditioning system, a refrigerant recovery unit must be used to recover the refrigerant. This refrigerant can then be recycled and reused, which is both environmentally safe and economical.

For complete system recovery, any of the High and Low service ports can be used (Refer to fig. 18 & 19). Energize liquid solenoid valve and measure the quantity of oil recovered. For the compressor only, use the service valve port and close the valves. The service valves open permits full flow of refrigerant to service port. Service valve closed permits flow of refrigerant from compressor to service port.

#### 11.3.5 Compressor Handling

Do not strike, drop or turn the compressor upside down. If the compressor is knocked over or turned upside down, rotate the compressor's magnetic clutch 5 to 6 times by hand to circulate the oil which has settled in the cylinder. Sudden

rotation with oil in the cylinder can cause valve damage and adversely affect durability.

#### 11.4 COMPRESSOR REMOVAL

11.4.1 When the compressor is operational

- Perform the “OIL RETURN OPERATION” (Refer to paragraph 10.9).

11.4.2 When the compressor is inoperable

- Perform the “Refrigerant Recovery” operation (Refer to paragraph 10.3.4).
- Remove the compressor.

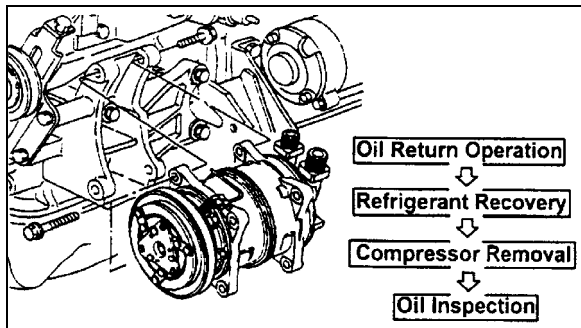

FIGURE 34: COMPRESSOR REMOVAL

#### 11.5 INSTALLATION PRECAUTIONS

The new compressor is filled with the specified quantity of compressor oil and nitrogen gas (N<sup>2</sup>). When mounting the compressor on the vehicle, take the following steps:

- Loosen the discharge side connector’s cap and gently release N<sup>2</sup> from compressor (Refer to figure 34).

**Note:** Take care not to let the oil escape.

- Slowly rotate the compressor’s magnetic clutch several times by hand to distribute the oil which has settled in the cylinders (Refer to figure 35).

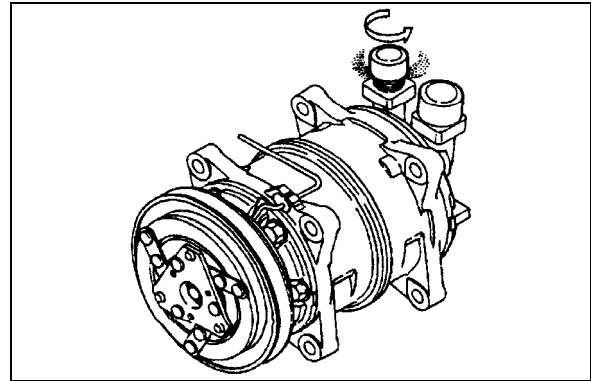

FIGURE 35: LOOSENING THE DISCHARGE SIDE CONNECTOR’S CAP

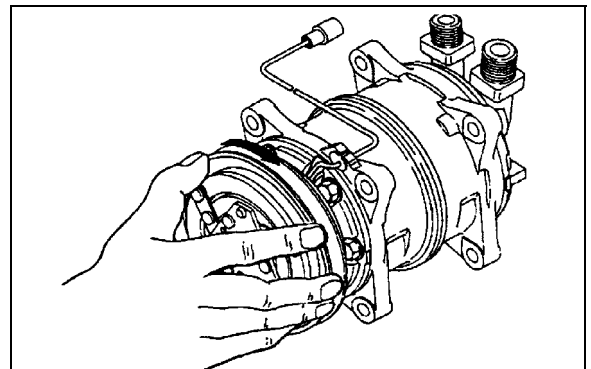

FIGURE 36: ROTATING MAGNETIC CLUTCH

- When using the old compressor in the system, the compressor should be installed after changing the oil.

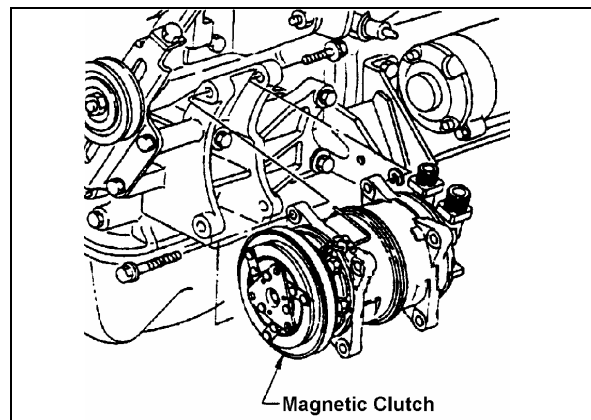

FIGURE 37: COMPRESSOR INSTALLATION

#### 11.6 COMPRESSOR OIL CHANGE

Each compressor is delivered filled with the specified quantity of compressor oil, depending on the type of air conditioning system. A label describing the amount/type of compressor oil is attached to the compressor.

## Section 22: HEATING AND AIR CONDITIONING

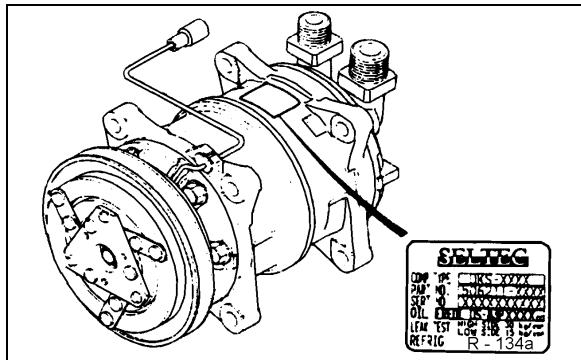

FIGURE 38: COMPRESSOR OIL LABEL

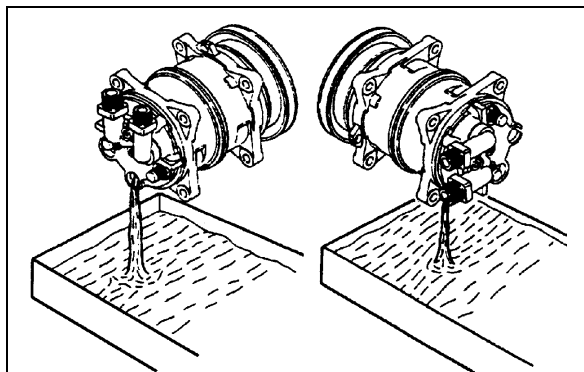

FIGURE 39: DRAINING THE OIL

- Check oil for contamination. Refer to PARAGRAPH 10.8: "COMPRESSOR OIL CONTAMINATION".
- Tighten the oil drain plug with a new o-ring lightly coated with clean compressor oil to specified torque.

### Torque: 13-15 Nm (9.4-10.8 Ft-Lbs)

- Add new compressor oil through the suction-side connector with the amount specified on the label (180 ml).

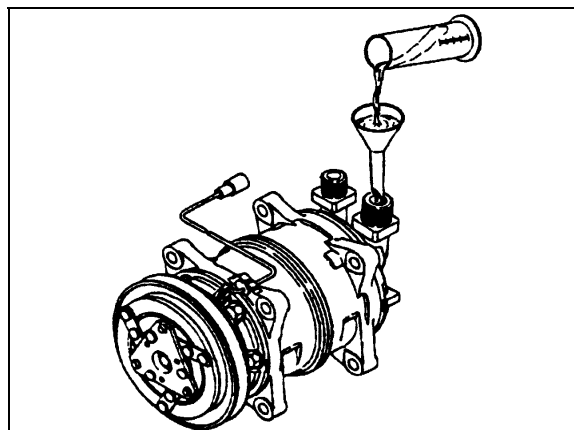

FIGURE 40: ADDING NEW COMPRESSOR OIL

### 11.6.1 Evacuating System Before Adding Refrigerant (Driver's or Auxiliary System)

When a system has been opened for repairs, change the filter dryer and evacuate the system. VIPs equipped with a driver's system must use high-pressure service port located on the other side of check valve and low-pressure port located alongside rear truss. (Fig. 18 and 19). It would be good practice to open the solenoid valve.

1. Connect two hoses equipped with a micron gauge between the high-pressure service port, the low-pressure service port and the vacuum pump.
2. With the unit service valves open and the vacuum pump valves open, start the pump and draw the manifold and hoses into a very deep vacuum (700 microns).
3. Close manifold valve
4. Shut down the vacuum pump.
5. Check to insure that vacuum holds. (If the pressure continues to rise, it indicates a leak or moisture in the system).
6. Charge the system with the proper amount of refrigerant through the service port near the check valve using recommended charging procedures.
7. Remove the hoses.

### 11.7 OIL ADDITION

The chart below shows the approximate amount of oil to be added to the system when replacing a component.

Component replaced	Typical amount of oil
Evaporator	50 cm <sup>3</sup> (1.7 ozs)
Condenser	30 cm <sup>3</sup> (1.0 ozs)
Filter-Dryer	10 cm <sup>3</sup> (0.3 ozs)

The amount of oil recovered with the refrigerant recovery should be added at the same time.



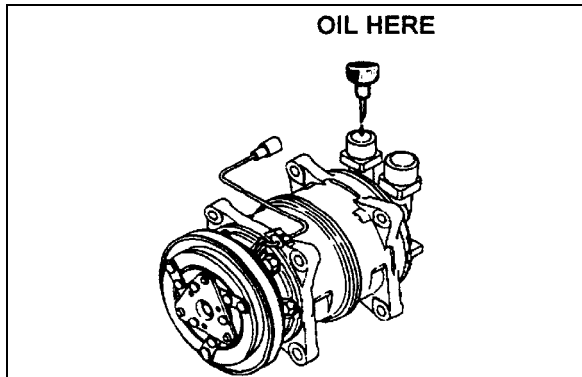

FIGURE 41: ADDING OIL AFTER REPLACING A COMPONENT

### 11.8 COMPRESSOR OIL CONTAMINATION

Unlike engine oil, no cleaning agent is added to the compressor oil. Even if the compressor is run for a long time, the oil never becomes turbid as long as there is nothing wrong with the compressor or its method of use. Inspect the extracted oil for any of the following conditions:

- Dirt in the oil.
- Change to a varnish color.
- Presence of foreign substance, metal shavings, etc. in the oil. When the oil extracted from the compressor is as described above, replace the oil as follows:
  1. Clean the interior of the system with approved method.
  2. Replace the filter-dryer.
  3. Supply with new oil as specified in paragraph 10.6: "COMPRESSOR OIL CHANGE".

### 11.9 OIL RETURN OPERATION

There is a close affinity between oil and refrigerant. During normal operation, part of the oil recirculates with the refrigerant in the system. Therefore, when checking the amount of oil in the system or replacing any system component, the compressor must be run in advance to ensure return. This procedure is as follows:

- If the amount of refrigerant in the system has decreased, charge to the proper amount.
- Start the engine and select fast idle.
- Set the fan speed to full air/full A/C and let run for 20 minutes.

### 11.10 OIL CHECK INTERVAL

Unlike engine oil, it is not necessary to frequently check or change the compressor oil. However, it is necessary to check and replenish or replace the compressor oil in the following cases:

- Whenever the compressor, evaporator, condenser or filter-dryer is replaced.
- Whenever refrigerant has leaked from the system, evaluate the amount of oily spot.
- Whenever refrigerant is suddenly released from the cooling cycle, replenish the compressor (180 ml) plus 150 ml.
- Whenever any oil-related problems occur in the cooling cycle.

### 11.11 LEAK TEST PROCEDURE WITH COMPRESSOR REMOVED

When a compressor is repaired, it must be checked prior to installation.

- Install the discharge and suction caps to the connector.

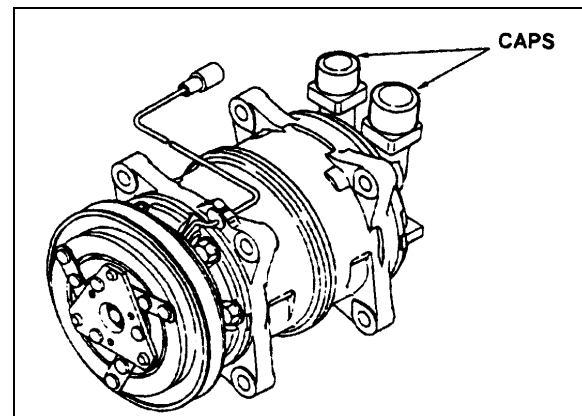

FIGURE 42: DISCHARGE AND SUCTION CAPS

- Fill the compressor with refrigerant through connector's suction port raising the pressure to at least 0.5 Mpa (70 psi).
- Check the compressor for leaks using a leak detector.

**Note:** Never leave the compressor upside down for longer than 30 seconds. This is because the oil inside the compressor will enter the cylinders, causing liquid compression which will damage the compressor's suction and delivery valves.

## Section 22: HEATING AND AIR CONDITIONING

### 11.12 TIGHTENING TORQUES

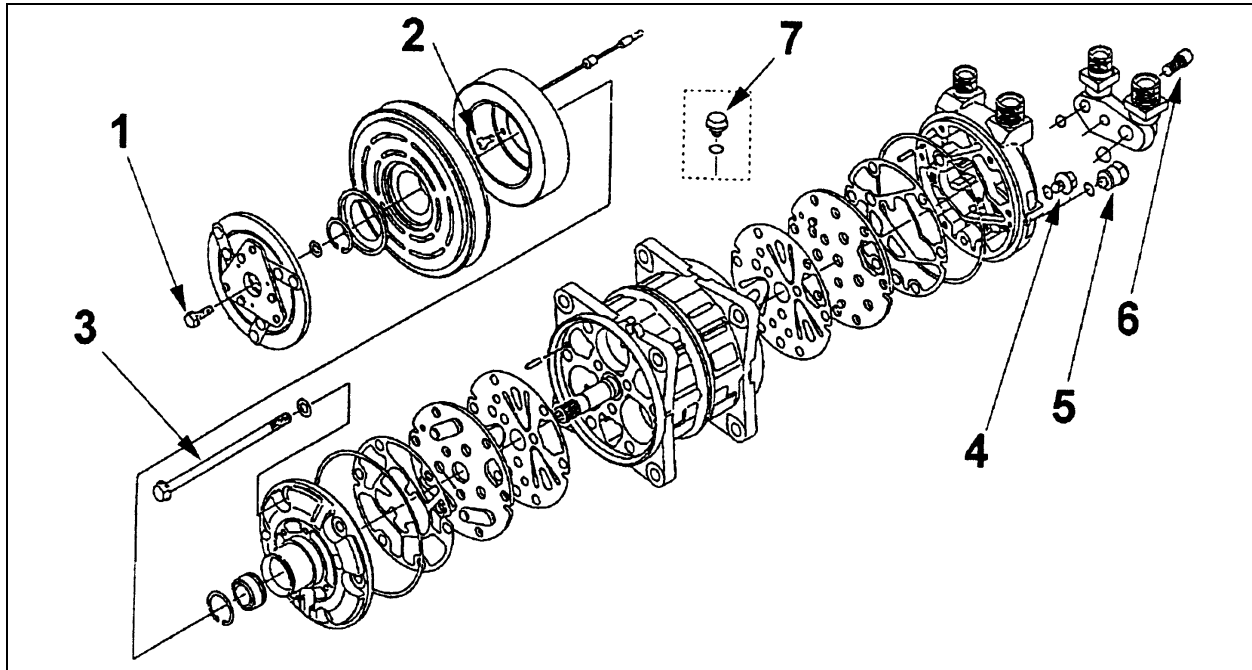

FIGURE 43: TIGHTENING TORQUES

PART	THREAD SIZE	TIGHTENING TORQUE
1. Bolt Armature	M6 x 1.0	12 - 14 Nm (8.7 - 10.1 Ft-Lbs)
2. Field Coil Screw	M5 x 0.8	4 - 6 Nm (2.9 - 4.3 Ft-Lbs)
3. Body Bolt	M8 x 1.25	20 - 24 Nm (14.5 - 17.3 Ft-Lbs)
4. Oil Drain Plug	M8 x 1.25	13 - 15 Nm (9.4 - 10.8 Ft-Lbs)
5. Pressure Relief Valve	3/8 - 24UNF	13 - 15 Nm (9.4 - 10.8 Ft-Lbs)
6. Connector Bolt	M8 x 1.25	20 - 24 Nm (14.5 - 17.3 Ft-Lbs)
7. Oil Filler Plug	M8 x 1.25	13 - 15 Nm (9.4 - 10.8 Ft-Lbs)

## 12. HEATING SYSTEM

The schematics of Figures 43 and 46 show respectively, the small heating and A/C systems and the central heating system with their components.

In addition to the normal heating provided by the engine, a preheating system (104,000 Btu/hr) (optional on coaches only) may have been installed in the vehicle.

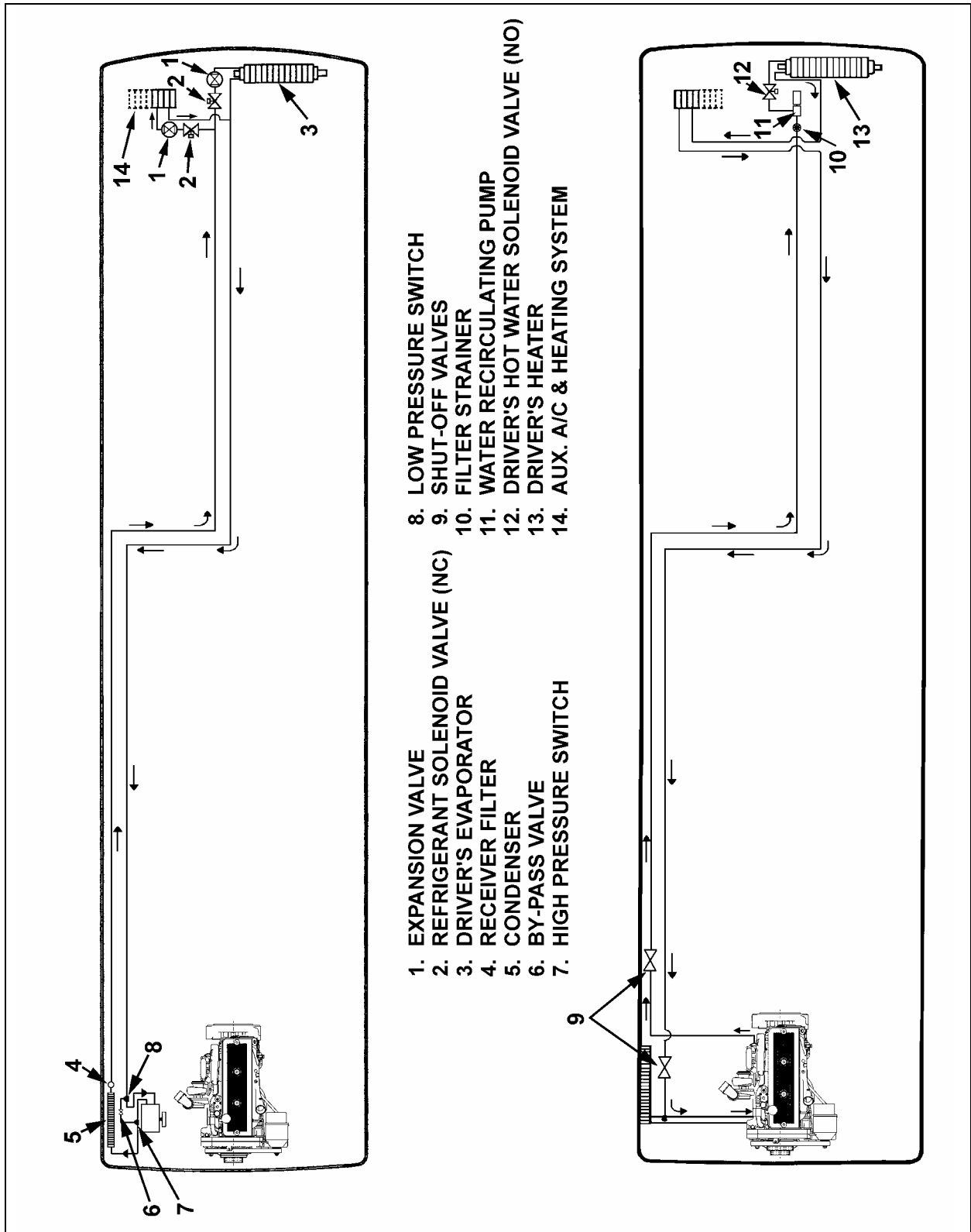

FIGURE 44: SMALL A/C & HEATING SYSTEMS PLUS AUXILIARY SYSTEM COMPONENTS

22233

## Section 22: HEATING AND AIR CONDITIONING

### 12.1 SMALL HEATING & AUX. SYSTEM

For vehicles equipped with small heating & auxiliary systems only, refer to figure 46. The small system is similar to the driver's portion of central system, except that the recirculating pump and the strainer are located on the ceiling of the spare wheel compartment. For more information on components, refer to paragraph 12.2: CENTRAL HEATING SYSTEM.

Furthermore, an auxiliary system is added in series on the return line of the small system, it increases the whole system heating capacity and gives the driver more options.

### 12.2 CENTRAL HEATING SYSTEM

The schematic of Figure 46 shows the central heating system and its components.

On coaches only, in addition to the normal heating provided by the engine, an optional preheating system (100,000 Btu/hr) may have been installed above the rear wheelhousing on the L.H. side.

### 12.3 DRAINING HEATING SYSTEM

To drain the entire system, refer to Section 05, "Cooling". If only the driver's or main heater core must be drained, refer to the following instructions.

#### 12.3.1 Draining Driver's Heater Core

1. Stop engine and allow engine coolant to cool.
2. Locate the normally open water solenoid valve on the ceiling of the spare wheel compartment (Fig. 44), disconnect its wiring connector, then connect a 24-volt external power source, using jumper cables, to close valve.

**Warning:** Before proceeding with the following steps, check that coolant has cooled down.

3. Loosen hose clamp, install an appropriate container to recover coolant, and disconnect silicone hose from water solenoid valve.
4. From inside of vehicle, remove the grill and the access panels. Open the purge valve located inside the HVAC unit on the driver's side (Fig. 45) to ensure an efficient draining.

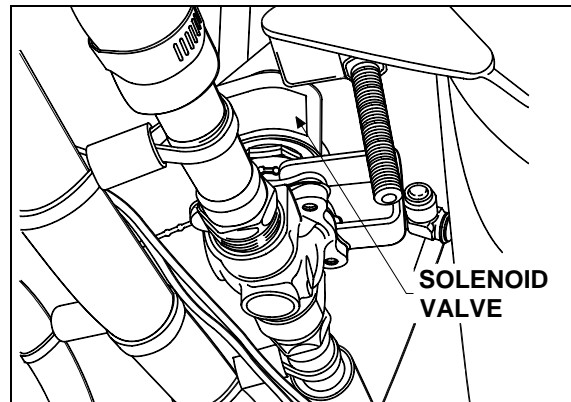

FIGURE 45: CEILING OF SPARE WHEEL COMPART. 22127

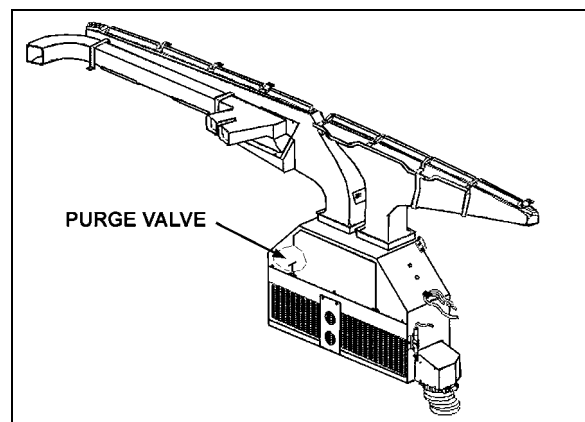

FIGURE 46: DRIVER'S HVAC UNIT 22171PV

#### 12.3.2 Draining Main Heater Core

1. Stop engine and allow engine coolant to cool.
2. Close both heater line shutoff valves. One is located in the engine compartment under the radiator fan gearbox, while the other one is located behind the L.H. hinged rear fender near the preheater. Refer to "Preheater System" in this section to gain access to the heater line shutoff valve.
3. Open the last L.H. side baggage compartment door, then pull the black release button located on the L.H. side in order to unlock and open the HVAC compartment door.

**Warning:** Before proceeding with the following step, check that coolant has cooled down.

4. Open drain cock in bottom of heater core, then open purge valve located on top of heater core (Fig. 47) in order to allow air to enter while draining.

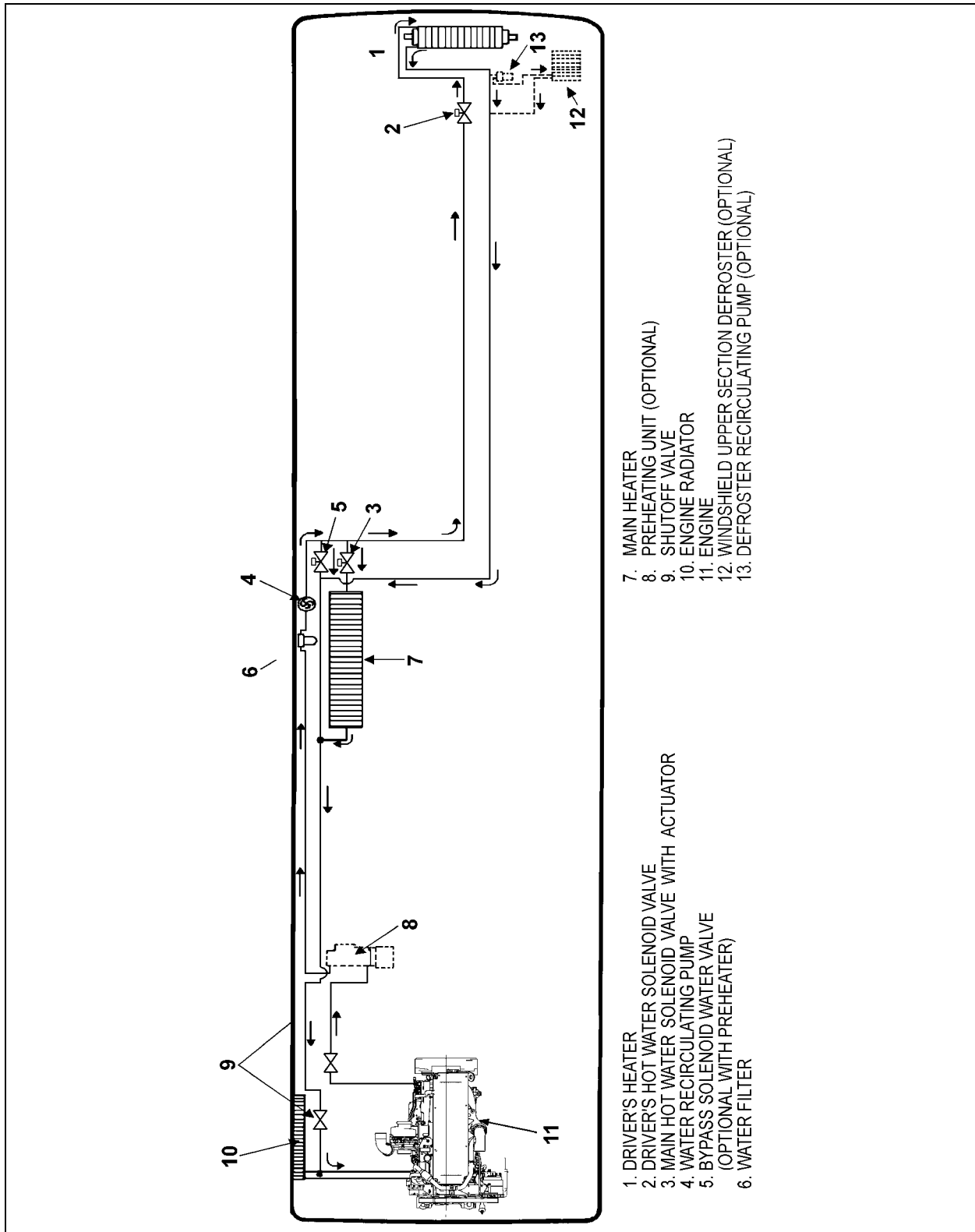

- |  |   |
|--|---|
| 1. DRIVER'S HEATER                                       | 7. MAIN HEATER                                    |
| 2. DRIVER'S HOT WATER SOLENOID VALVE                     | 8. PREHEATING UNIT (OPTIONAL)                     |
| 3. MAIN HOT WATER SOLENOID VALVE WITH ACTUATOR           | 9. SHUTOFF VALVE                                  |
| 4. WATER RECIRCULATING PUMP                              | 10. ENGINE RADIATOR                               |
| 5. BYPASS SOLENOID WATER VALVE (OPTIONAL WITH PREHEATER) | 11. ENGINE  |
| 6. WATER FILTER  | 12. WINDSHIELD UPPER SECTION DEFROSTER (OPTIONAL) |
|  | 13. DEFROSTER RECIRCULATING PUMP (OPTIONAL)       |

FIGURE 47: CENTRAL HEATING SYSTEM COMPONENTS

22230

## Section 22: HEATING AND AIR CONDITIONING

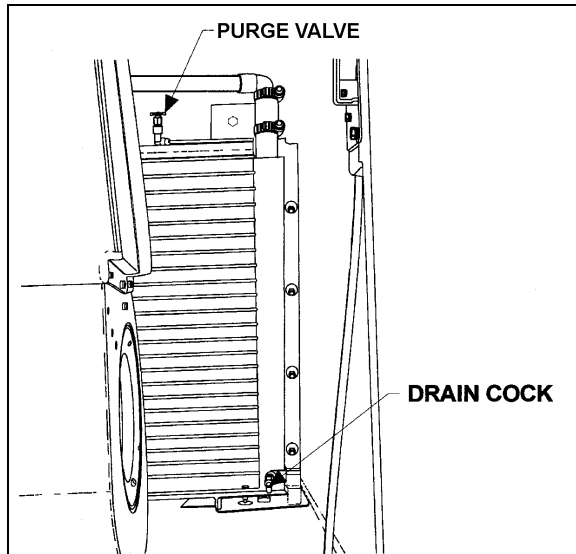

FIGURE 48: HVAC COMPARTMENT

22229

### 12.4 FILLING HEATING SYSTEM

1. Ensure that the drain hose is reconnected and the purge valves and drain cock are closed.
2. Open the surge tank filler cap and slowly fill the system to level of filler neck.
3. After initial filling, the water valves should be open and the water recirculating pump should be energized to assist in circulating coolant through the heating system. To perform this operation, start the engine, switch on the HVAC control unit, both driver and passenger sections, and set temperature to their maximum positions in order to request the heating mode in each of these sections.
4. When coolant level drops below the surge tank filler neck, slowly fill the system to level of filler neck.
5. If vehicle is equipped with a windshield upper section defroster, open front baggage compartment R.H. side door. Locate recirculating pump on top of front wheelhousing, momentarily pinch the hose located between the recirculating pump suction and the defroster outlet connector to ensure windshield upper section defroster complete filling.
6. Once the level has been stabilized, replace cap.

### 12.5 BLEEDING HEATING SYSTEM

Whenever the heating system has been drained and refilled, or the system has run low on coolant and coolant has been added, it is necessary to bleed air from heating system. Locate the purge valve illustrated in Figures 45 and 47, and open them momentarily until no air escapes from the lines

### 12.6 SOLDERING

Before soldering any part of the system, make sure the area is well ventilated. Use (stay clean) flux sparingly and apply solder (95-5 round wire 1/8 inch [3,1 mm]). After completing repairs, test for leaks.

When using heat at or near a valve, wrap with a water saturated rag to prevent overheating of vital parts.

### 12.7 DRIVER'S WATER SOLENOID VALVE

A two-way normally open, internal pilot-operated solenoid valve designed for smooth closing is used to control the coolant flow through the driver's heating unit. It is mounted on the coolant inlet line of the driver's heating unit, and is accessible through the spare wheel compartment (see fig. 44). The valve cannot be manually bypassed.

#### 12.7.1 Improper Operation

1. Faulty control circuit: Check the electric system by energizing the solenoid. A metallic clicking noise indicates that the solenoid is operating. Absence of clicking indicates a loss of power or a defective solenoid. Check for open breaker, open-circuited or grounded coil, broken lead wires.
2. Burned-out coil: Check for open-circuited coil. Replace coil if necessary.
3. Low voltage: Check voltage across the coil leads. Voltage must be at least 85% of nameplate rating.
4. Excessive leakage: Disassemble valve and clean all parts. Replace worn or damaged parts with a complete repair kit for best results.

### 12.7.2 Coil Replacement

Turn off electrical power supply and disconnect lead wires. Proceed in the following manner:

1. Remove retaining clip, spacer, name plate and cover.
2. Slip spring washer and coil off the housing.
3. Coil is now accessible for replacement. Reassemble by reversing sequence of disassembly. Refer to exploded view (Fig. 52) for identification and location of parts.

**Note:** Solenoid must be completely reassembled, as the cover and internal parts complete the magnetic circuit.

**Caution:** When metal retaining clip disengages, it springs upwards.

### 12.7.3 Valve Disassembly

1. Drain driver's heating unit as previously explained in this section under paragraph "Draining Heating System".
2. Disconnect connector from coil connector.
3. Disassemble valve in an orderly fashion paying careful attention to exploded view (Fig. 49) provided for identification of parts.
4. Remove retaining clip and slip the entire solenoid enclosure off the solenoid base.

**Caution:** When metal retaining clip disengages, it springs upwards.

5. Unscrew solenoid base and remove core, plugnut gasket, plugnut assembly and gasket.
6. Remove the four bonnet screws and valve bonnet, disc holder, spring, diaphragm assembly and body gasket.
7. All parts are now accessible for cleaning or replacement. Replace worn or damaged

parts with a complete repair kit for best results.

**Caution:** Do not damage valve seat in any manner, as its sealing feature will be affected, thus resulting in continuous leakage.

### 12.7.4 Valve Reassembly

1. Reassemble in reverse order of disassembly, paying careful attention to exploded view provided for identification and placement of parts (Fig. 48).
2. Replace body gasket and diaphragm assembly. Locate bleed hole in diaphragm, located approximately 45° from valve outlet.
3. Replace disc holder spring and disc holder.
4. Replace valve bonnet screws. Torque bonnet screws in a criss-cross manner to 95 ± 10 inch-pounds.
5. Install gasket, plugnut assembly and plugnut gasket. Position core on plugnut assembly.
6. Replace solenoid base and torque to 175 ± 25 inch-pounds.
7. Refill heating system as previously stated under paragraph "Filling Heating System", then bleed air from the driver's heating unit as stated previously under paragraph "Bleeding heating system".
8. After maintenance, operate the valve a few times to be sure of proper opening and closing.

**Note:** Should diaphragm assembly become disassembled, be sure to replace the diaphragm spring support with lip facing upward towards the valve bonnet.

Section 22: HEATING AND AIR CONDITIONING

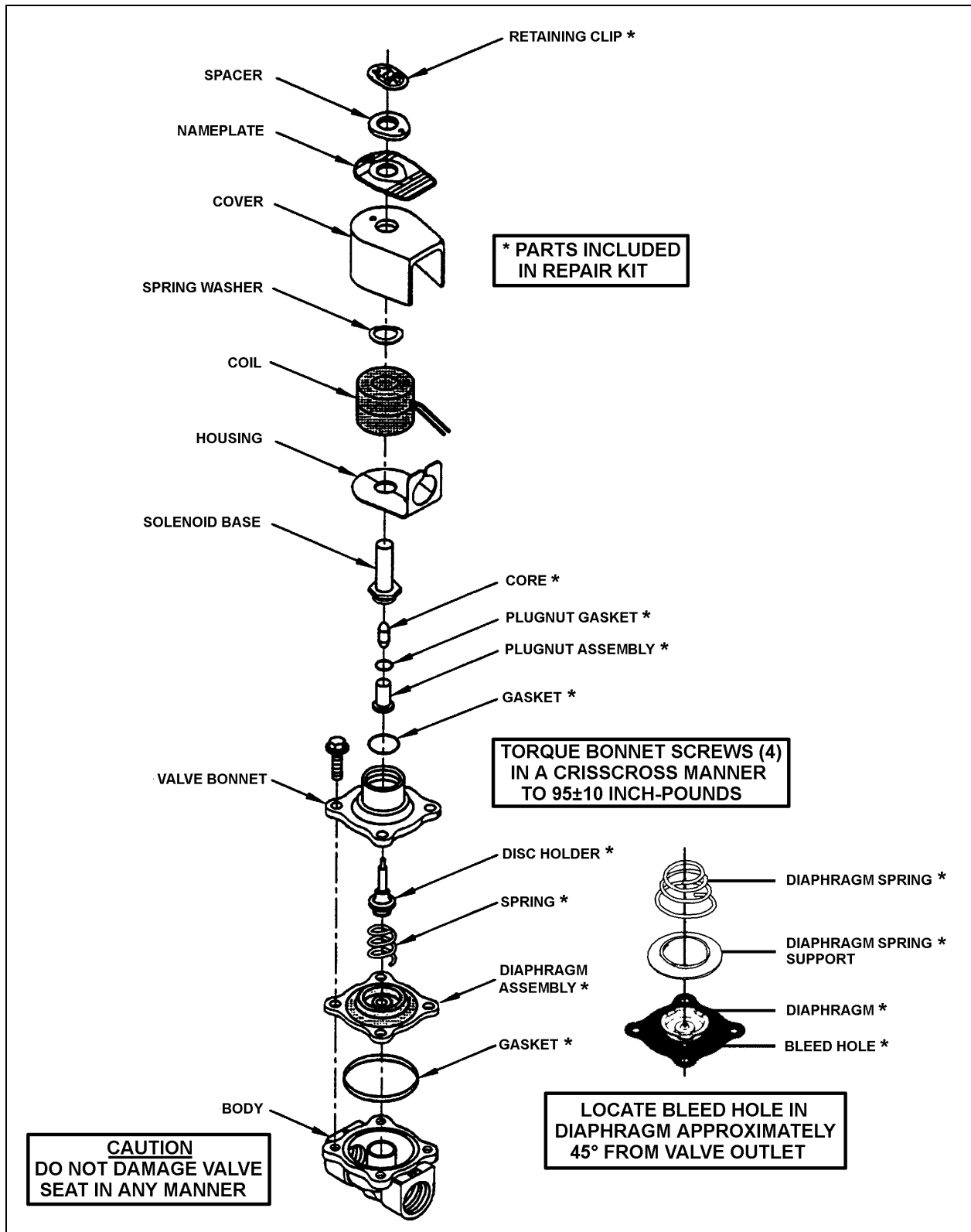

FIGURE 49: DRIVER'S WATER SOLENOID VALVE

22216



## Section 22: HEATING AND AIR CONDITIONING

### 12.8 CENTRAL HOT WATER PNEUMATIC VALVE ASSEMBLY

#### 12.8.1 Description

The flow of hot water to the vehicle's central heater core is controlled by a NO pneumatic water valve assembly. The valve, located in the evaporator compartment, is designed so that the pilot solenoid valve, which is part of the assembly opens and closes a port which directs air pressure to the actuator casing, thereby opening or closing the valve.

When the vehicle is operating with no current to the pilot solenoid valve, no air pressure is admitted to the actuator casing, the cylinder spring pushes up against the cylinder, thereby keeping the water valve open.

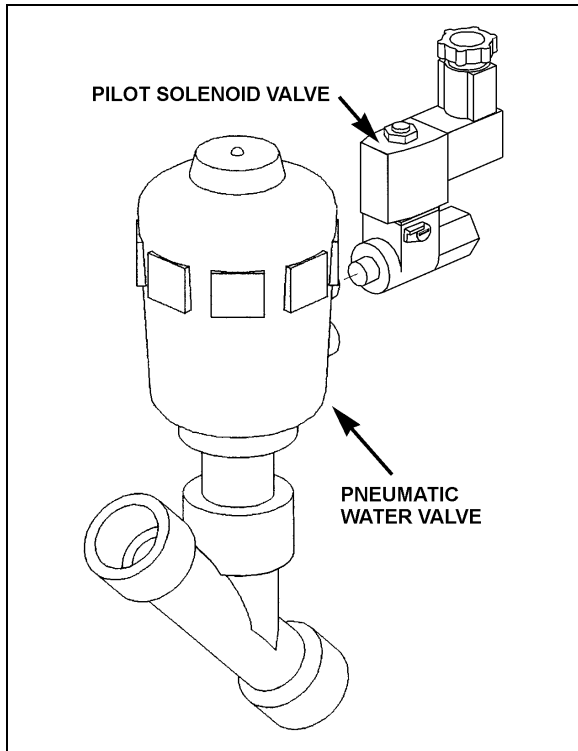

FIGURE 50: CENTRAL HOT WATER PNEUMATIC VALVE ASSEMBLY

22240

The central heater water valve requires a minimum amount of maintenance. The valve should be free of dirt sediment that might interfere with its operation. No other maintenance is needed unless a malfunction occurs.

#### 12.8.2 Pneumatic Water Valve Disassembly

1. Shut off air supply pressure and electrical current to the pilot solenoid valve. Disconnect wires.
2. The water valve need not be removed from the line. Unscrew nipple, the actuator casing, tube, spindle and closure member can be removed (Fig. 50).
3. Remove the snap ring using a pair of pliers.
4. You can now access all seals for replacement

Pneumatic water valve replacement seal kits:

- Water Side: 871311
- Actuator Side: 871312

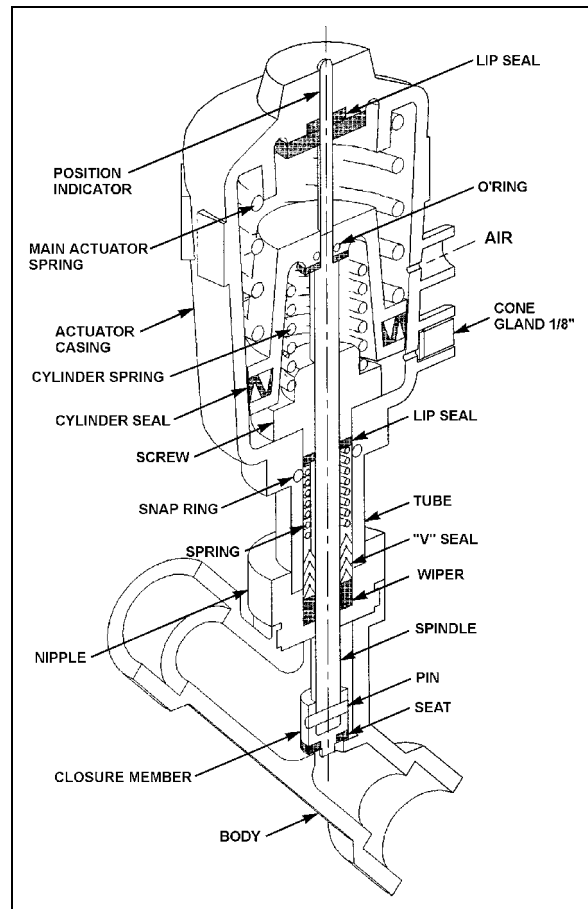

FIGURE 51: PNEUMATIC WATER VALVE

22241

## Section 22: HEATING AND AIR CONDITIONING

### 12.8.3 Pneumatic Water Valve Reassembly

1. Assemble the actuator casing, tube, nipple, spindle and closure member.
2. Tighten the nipple in place in the body cavity as per figure 50. Fasten pilot solenoid valve to the pneumatic water valve. Reconnect air supply pressure and electrical current to the pilot solenoid valve.
3. Check for proper operation.

### 12.8.4 Pilot Solenoid Valve

1. No maintenance is needed unless a malfunction occurs.
2. A pilot solenoid valve replacement seal kit is available: 871311.

### 12.8.5 Valve Troubleshooting

PROBLEM	PROCEDURE
Valve fails to close.	<ol style="list-style-type: none"> <li>1. Check electrical supply with a voltmeter. It should agree with nameplate rating.</li> <li>2. Check pressure at pilot solenoid valve inlet. It must be at least equal to the minimum pressure stamped on the nameplate. It should not go below minimum while valve is operating.</li> </ol>
Valve fails to open.	<ol style="list-style-type: none"> <li>1. Check that the closure member assembly, and that main actuator and cylinder springs are free to travel.</li> <li>2. Check that there is no restriction to the air escaping from the actuator casing.</li> <li>3. Make sure that pilot solenoid valve operates properly.</li> </ol>

## 12.9 WATER RECIRCULATING PUMP

This vehicle is provided with a water recirculating pump which is located in the HVAC compartment (Fig. 52) or on the ceiling of the spare wheel compartment for VIP converted vehicles equipped with a small A/C. The water recirculating pump consists of a centrifugal pump and an electric motor which are mounted on a common shaft in a compact assembly.

The motor is equipped with pre-lubricated sealed ball bearings which require no maintenance. A self-adjusting mechanical shaft seal is incorporated in this assembly to prevent coolant leakage between the pump cavity and armature shaft. This seal derives its lubrication from the liquid pumped, and **it will be destroyed if permitted to operate dry.**

The pump requires no periodic maintenance other than replacement of motor brushes. Replacement of motor brushes can be performed without removing the pump assembly.

Visual inspection of the pump should be made while the pump is in operation to determine if the shaft seal is intact. If there is evidence of coolant leakage, the unit must be disassembled for corrective measures. Disassembly of the pump will be necessary only in the case of a seal leak, bearing failure, or motor failure.

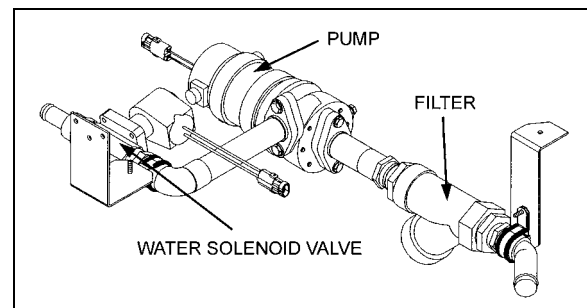

FIGURE 52: VIP WATER RECIRCULATION PUMP INSTALLATION

### 12.9.1 Removal

1. Stop engine and allow engine coolant to cool.

## Section 22: HEATING AND AIR CONDITIONING

2. Close shutoff valves on the line located in the rear electric compartment. Refer to "Preheater System" in this section to gain access to the heater line shutoff valve.
3. Disconnect the electrical wiring from the motor.

**Warning:** Before proceeding with the following steps, check that coolant has cooled down.

4. Remove the drain plug at the bottom of the pump and place a container to recover the residual coolant in the line.
5. Disconnect water lines from the pump at the flange connections.
6. Remove the two clamps holding the pump motor to its mounting bracket. Remove the pump with the motor as an assembly.

### 12.9.2 Disassembly

Refer to figure 52

1. Remove two brush caps (16) and two brush assemblies (15). When removing brushes, note the position of the brush in the tube. Brush life is significantly decreased if brushes are not replaced properly.
2. Remove the pump cover (2) by removing eight head screws. Remove cover carefully to prevent damage to gasket (3).
3. Remove gasket (3).
4. Remove two hex nuts and lock washers which hold pump assembly to the motor.
5. Remove the pump from the motor as follows.
  - a. Install puller tool assembly (MP Co. Part No. 24702 or equivalent) to pump body (12) using four screws removed from the pump cover (2).
  - b. Tighten the puller screw to press the motor shaft out of the impeller hub. The pump is now free from the motor.
6. Remove the puller tool.
7. Remove impeller (4) and components of the pump seal assembly (5).

**Caution:** Do not scratch or mar the sealing surface of this seat, as its sealing feature will be affected, thus resulting in continuous leakage

### Inspection

Components removed from the recirculating pump and motor assembly should be compared with new parts to determine the degree of wear.

### 12.9.3 Brushes

- 1) When removing brushes, note the position of the brush in the tube. Brush life is shortened if the brushes are not replaced properly.

- 2) Examine brushes for the following:

- a) Wear

Replace the brushes if less than 25% of the usable brush is left (less than 0.300 inch (8 mm)).

- b) Chipped edges

Chips can be caused by improper handling or installation. Badly chipped brushes should be replaced regardless of their length.

- c) Annealed brush spring

This can be detected by noting the resiliency of the spring. Annealing is caused by failing to tighten the brush caps properly, thus not providing a good low resistance contact between the terminal and the brush tube. Replace brushes showing evidence of annealed springs.

- d) Frayed or broken pigtail

An improperly installed brush may have the pigtail (shunt) pinched under the terminal or between the coils of the spring. If the pigtail is badly frayed or broken, replace the brush.

**Section 22: HEATING AND AIR CONDITIONING**

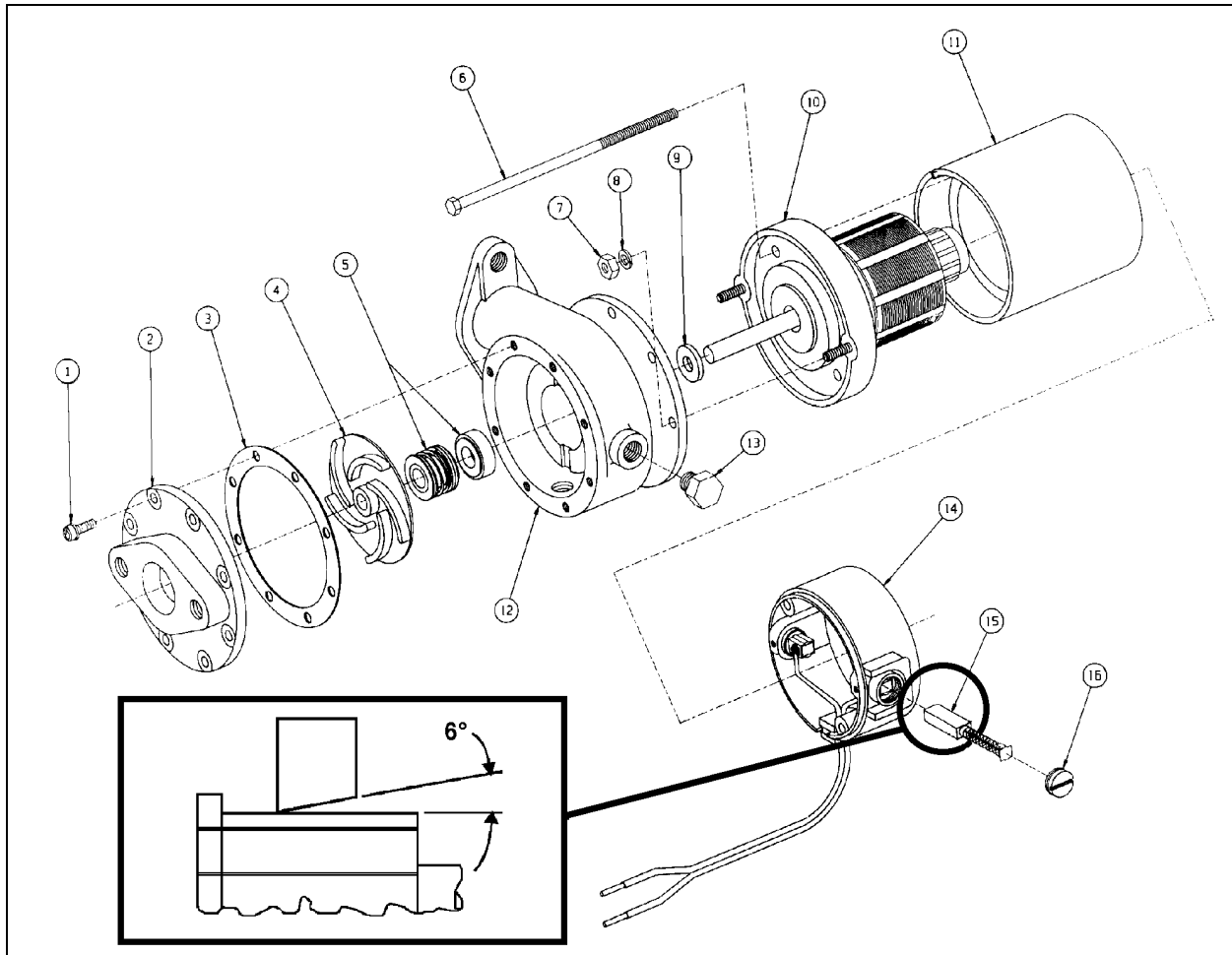

**FIGURE 53: WATER RECIRCULATING PUMP**

22056

ITEM	DESCRIPTION	QTY.	ITEM	DESCRIPTION	QTY.
	<b>MOTOR</b>			<b>IMPELLER</b>	
	Motor Assembly	1	4	Impeller - Brass	1
11	Stator	1		<b>HOUSING</b>	
14	End Frame Assembly	1	12	Body - Brass	1
10	Armature adapter Assembly	1	2	Cover - Brass	1
15	Brush Assembly	2	1	Screw and Washer Assembly	8
16	Cap (brush holder)	2	3	Gasket	1
6	Case bolt 10-32 X 5	2	9	Slinger	1
7	10-32 Hex Nut	2	13	Drain Plug - 1/8" NPT Brass	2
8	#10 Lock Washer	2		<b>SEAL</b>	
			5	Seal Assy - Silicon Carbide/Carbon	1

## Section 22: HEATING AND AIR CONDITIONING

- 3) Observe the following factors when replacing brushes
  - a. The face of a new brush is carefully cut to cause proper seating during the "wear-in" period.
  - b. Improper installation can harm both the brush and the commutator.
  - c. Replacement brushes should be of the proper grade.
  - d. New brushes have a six- (6) degree angle. The brush should always be inserted so that the angle is open away from the pump end of the assembly (inset, Fig. 52)
  - e. Brush performance will be affected if the spring and terminal are not properly placed in the brush tube. The spring should be free over its entire length and the terminal should make good contact with the metal brush tube insert.

### 12.9.4 Bearings

Refer to figure 52.

1. Rotate the motor shaft. If the ball bearings show evidence of wear, they should be replaced.
2. To use of a bearing puller is recommended when removing the bearings to help prevent damaging the armature winding or the commutator.
3. Replacement bearings should be pressed into the same exact location as the original bearings.
4. It is recommended that a suitable sealant (such as Loctite or equivalent) be used between the shaft and the bearing, if the fit is not tight enough to prevent the shaft from spinning inside the inner race.
5. After replacing the bearings, check the position of the commutator in the motor by looking down into the brush tube. Neither the riser nor the edge of the commutator should be visible.

### 12.9.5 Commutator

1. The commutator is a precise assembly. Although it is solidly built and made of a fairly tough material, careless handling can easily ruin it.
2. The commutator should be refinished only on equipment that provides good concentricity and the proper finish.
3. The commutator should be refinished if a micrometer reading shows a difference between "in track" and "off track" diameter of 0.187 inch (4,7 mm) or more.
4. The commutator should be carefully undercut with a 0.025 inch (0,6 mm) or less slot width.
5. A 25 to 50 micromesh finish is desirable on a new or refinished commutator.
6. The commutator should not be touched with the fingers since sweat and body oils will rapidly discolor and oxidize its surface.

### 12.9.6 Miscellaneous

Refer to figure 52.

1. Check the shaft slinger (9) to make sure it is tight on the motor shaft. If the slinger slips on the shaft, it should be replaced.
2. Inspect seal assemblies (5) to determine wear. If the seal has leaked, or is badly worn, it is recommended that a complete new seal assembly be installed.
3. The impeller (4) is a press fit on the armature shaft. This press fit must be maintained to prevent the impeller from slipping. Install a new impeller if necessary.

### 12.9.7 Assembly

Refer to figure 52.

1. Install slinger (9) on the motor shaft.
2. Assemble body (12) to the motor.
3. Install seal assembly (5).
4. Install impeller (4) in the following manner:
  - a) Place the impeller on a flat surface with the vanes against the flat surface.

## Section 22: HEATING AND AIR CONDITIONING

---

- b) Invert the motor and pump body assembly, then pilot the pump shaft into the impeller bore. **DO NOT HAMMER** on the motor shaft extension at rear of motor.
- c) Press on motor and pump body until the machined face of the pump body is flush with the face of the flat surface on which the impeller is resting. The face of the impeller vanes must now be flush with the machined face of the pump body.
5. Install gasket (3). This gasket serves both to seal the cover and to establish the proper clearance between the face of the impeller and the pump cover.
6. Attach cover (2) to the pump body using eight head screws (1).
7. Install motor brushes assembly (15) and brush caps (16).

### 12.9.8 Installation

1. Apply gasket cement to the pump body line adapter and to the line flanges, put the two gaskets in place, and connect water lines from the pump at the flange connections. Position the pump and motor assembly on the mounting bracket. Position the mounting clamps over the motor and secure with mounting bolts.
2. Apply pipe sealant on threads of drain plug, and screw it in place.
3. Connect electrical wiring to the pump motor.
4. Open shutoff valve located behind the L.H. Side hinged rear fender (near the preheater). Refer to "Preheater System" in this section to gain access to the heater line shutoff valve.
5. Fill the cooling system as previously instructed in this section under "*Filling Heating System*", then bleed the system as previously instructed in this section under "*Bleeding Heating System*".

### 12.10 WATER FILTER

This vehicle is provided with a cleanable water filter, which is located in the HVAC compartment

(refer to Fig. 16 and 53 (behind the right air duct)).

#### 12.10.1 Maintenance

Filter maintenance consists in changing the element at break-in 3000 miles (4 800 km), and subsequently every 50,000 miles (80 000 km) or once a year, whichever comes first.

**Note:** *Each time soldering is performed on any water pipe of the heating system, operate heating system a few minutes so that any foreign matter will be routed to the filters. Clean filters.*

#### 12.10.2 Filter Servicing

1. Stop engine and allow engine coolant to cool.
2. Close shutoff valve on the line located in the rear electric compartment. Refer to "Preheater System" in this section to gain access to the heater line shutoff valve.

**Warning:** *Before proceeding with the following steps, check that coolant has cooled down.*

3. Rotate bowl (6) counterclockwise and remove.
4. Remove element (5) from housing. Discard all disposable elements. These elements are not cleanable (Fig. 53).
5. Place new, clean element in housing, centering it on location in the head.
6. Inspect bowl seal and replace if necessary.
7. Replace bowl. Rotate clockwise and hand-tighten.
8. Correct coolant level in surge tank as instructed previously in this section under "*Filling Heating System*".

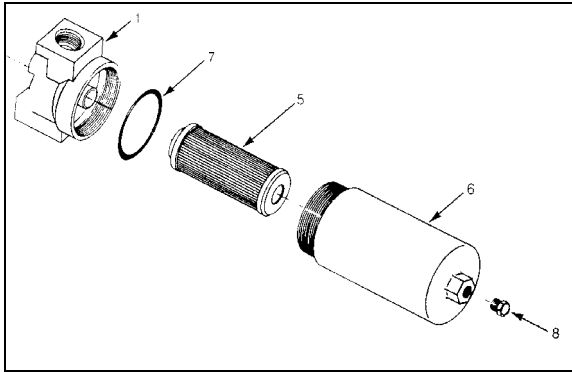

FIGURE 54: WATER FILTER

22057

### 12.11 BYPASS SOLENOID WATER VALVE (OPTIONAL)

This valve is optional and is installed on the vehicle equipped with a preheater. The valve is located in the HVAC compartment (Fig. 16). This valve is similar to the driver's liquid solenoid valve. Refer to Fig. 48 for part names.

#### 12.11.1 To Remove or Change the Coil

- Stop engine and allow engine coolant to cool.
- Close shutoff valve on the line located in the rear electric compartment. Refer to "Preheater System" in this section to gain access to the heater line shutoff valve.

#### To remove the solenoid coil:

First take out the retaining screw at the top of the coil housing. The entire coil assembly can be lifted off the enclosing tube.

#### To reassemble:

Make sure that the parts are placed on the enclosing tube in the following order:

Be sure to change electrical data plate according to coil specifications change.

1. Place coil and yoke assembly on the enclosing tube. Lay data identification plate in place.
2. Insert the coil retaining screw, rotate housing to proper position and tighten screw securely.

#### 12.11.2 Valve disassembly and Reassembly

##### Disassembly:

This valves may be taken apart by removing the socket head screws which hold the body and bonnet together. After removing the screws, carefully lift off the bonnet assembly (upper part of the valve). Don't drop the plunger. The diaphragm can now be lifted out. Be careful not to damage the machined faces while the valve is apart.

**Note:** The above procedure must be followed before brazing solder type bodies into the line.

##### Reassembly:

Place the diaphragm in the body with the pilot port extension up. Hold the plunger with the synthetic seat against the pilot port. Make sure the bonnet O-rings are in place, the bonnet assembly over the plunger, and that the locating sleeve in the bonnet enters the mating hole in the body. Insert body screws and tighten uniformly.

### 13. PREHEATING SYSTEM (OPTIONAL ON COACHES ONLY)

The preheater is located over the rear wheelhousing, behind the vehicle's L.H. side rear fender.

To gain access to the preheater and the heater line shutoff valve, remove the L.H side rear fender.

This Auxiliary Preheating System is used for preheating and retaining the heat of water-cooled engines. It can be used before starting the engine to ease it's starting and to provide immediate inside heat upon operation of the heating system. It can also be used with engine running to maintain coolant heat and maintain the set temperature inside vehicle.

## Section 22: HEATING AND AIR CONDITIONING

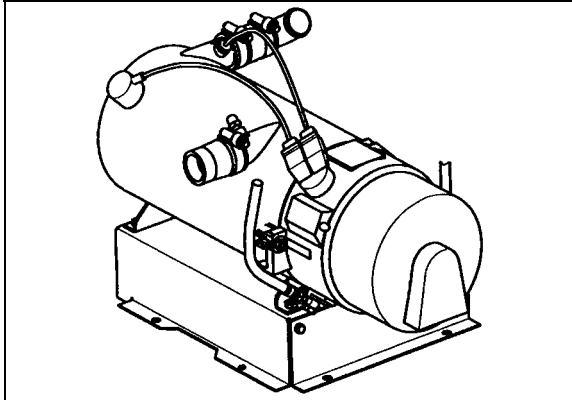

FIGURE 55: WEBASTO PREHEATER (104,000 BTU) 22224

The heater operates independently from the vehicle engine. It is connected to the cooling and heating circuits, the fuel system and the electrical system of the vehicle.

The pilot lamp turns on when the heater is switched on. Combustion air flows in to flush out the combustion chamber and the water circulation pump is put into operation. The fuel metering pump conveys fuel in precise doses to the combustion chamber where fuel and combustion air form a combustible mixture which is ignited by the glow plug.

Once the flame sensor has signaled to the control unit that combustion has taken place correctly, the glow spark plug and ignition coil are switched off.

The hot combustion gases are diverted at the end of the flame pipe, then pass through the indirect heating surfaces of the heat exchanger and transmit their heat to the water passing through the heat exchanger.

The heat is thermostatically controlled and operates intermittently, i.e. the switched-on times of the burner vary depending on the heat requirement. The water temperature depends on the setting of the built-in water thermostat.

The water circulation pump remains in operation as long as the heater is operating, even in the regulation intervals and during the delayed cutout of the switched-off heater. The pump can also be operated independently from the heater by means of an appropriate circuit. The heater can be switched on at any time, even during the

delayed cutout period. Ignition takes place once this delay time is over.

When the heater is switched off, the fuel supply is interrupted. The flame goes out, and at the same time a delayed cutout of some 2.5 minutes begins. The combustion air still flowing flushes the remaining combustion gases out of the chamber and cools off the hot parts on the exhaust side of the heat exchanger, while the water circulation pump, still running, transmits the heat present in the heat exchanger, thus preventing local overheats. Once the delayed cutout time is over, both the combustion air blower and the water circulation pump switch off automatically.

A cutout will take place in case of any failure of the preheater.

### 13.1 OPERATION

Switch on the heater. The operation indicator lamp comes on and the heater motor and circulating pump begin to run. After about 10-25 seconds the solenoid valve opens and fuel is sprayed into the combustion chamber. At the same time, the electronic ignition unit produces high voltage (8000 V) and the mixture of fuel and air in the combustion chamber is ignited by the spark on the ignition electrodes. The flame is indicated by the flame detector, then the electronic ignition unit stops producing high voltage and combustion continues by itself (spark on electrodes is required only to ignite the flame). At this moment, the heater is working and producing heat.

If the heater is switched off by the on/off switch, the solenoid valve interrupts fuel supply, combustion stops and indicator lamp turns off. Combustion air fan still blows air, cleaning the combustion chamber of any fumes and cooling down the combustion chamber. Coolant circulation pumps coolant, making a purge cycle for approximately 2-3 minutes, thus protecting the heater against overheating.

If the heater is not switched off by the on/off switch, the control thermostat will switch off the heater when coolant temperature reaches  $165^{\circ} \pm 6^{\circ}\text{F}$  ( $75^{\circ} \pm 3^{\circ}\text{C}$ ) and turns it on at  $154^{\circ} \pm 9^{\circ}\text{F}$  ( $68^{\circ} \pm 5^{\circ}\text{C}$ ). During this time, the heater (combustion) is off and the indication lamp and



coolant pump are on. Combustion air fan blows air for 2-3 minutes and then turns off.

### 13.2 PREHEATING SYSTEM TIMER

The timer, located on L.H. lateral console is used to program the starting and stopping time of the preheating system. The system indicator light, located on the timer, illuminates when the system is functional.

**Caution:** The preheating system should not operate for more than one hour before starting engine as this could discharge batteries.

**Warning:** Preheating system must not operate when vehicle is parked inside or during fuel fill stops.

**Note:** Preheating system uses the same fuel as the engine.

In case of failure:

1. Shut off and turn on again.
2. Check main circuit breaker and overheat fuse.
3. Have system repaired in a specialized shop.

#### 13.2.1 Timer operating instructions (Webasto)

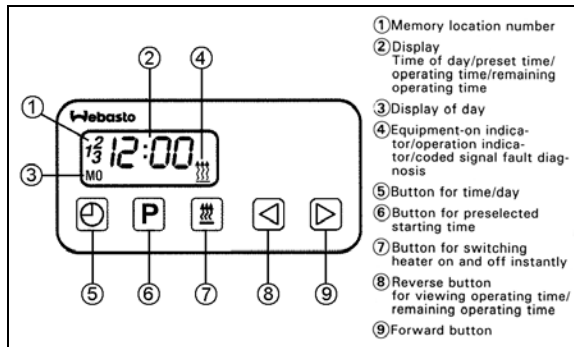

FIGURE 56: WEBASTO

22223

These instructions refer to the timer illustrated in figure 55. They are the same instructions provided in the Webasto instruction booklet, provided with your vehicle.

#### Remaining Operating Time

The remaining operating time refers to the period of time the heater still continues to remain in operation. It may be changed while the heater is in operation.

#### Setting the Digital Timer

After the power has been connected, all symbols on the digital display are flashing. The time of the day and the day of the week must be set.

All flashing symbols of the timer can be set by means of the Forward (9) or Reverse (8) buttons.

When buttons (8) and (9) are pressed for more than 2 seconds, the quick digit advance mode is activated.

#### Setting the Time and Day of the Week

1. Press button (5) for more than 2 seconds (time display flashes).
2. Press (8) or (9) button to set the time of day.
3. Wait 5 seconds. The time of day is stored (time of week flashes).
4. Press (8) or (9) button to set the correct day of week.
5. Wait 5 seconds. The day of week is stored.

#### Viewing the Time (Ignition ON)

Continuous display of current time and day of the week.

#### Viewing the Time (Ignition OFF)

Briefly press button (5) to display current time and day for 5 seconds.

#### Switching Heater ON (Instant Heating)

##### With Ignition ON:

Press button (7). Heater is switched on (continuous operation) and continues to operate until button (7) is pressed again or ignition is switched off.

**Note:** If the ignition is switched off while heater is in operation, the remaining operating time of 5 minutes flashes on the display and the heater will continue to operate for this period of time.

##### With Ignition OFF:

## Section 22: HEATING AND AIR CONDITIONING

---

Press button (7). Heater is switched on for preset operating time (the factory-set heater operating duration is 60 minutes).

### Switching Heater OFF

Press button (7). The heater starts its after-run cycle and switches off thereafter.

### Presetting Operating Duration

1. Press button (6). Memory location number flashes.

**Note:** *By repeatedly pressing button (6), starting time 2 or 3 can be preset.*

2. Press button (8) or (9) until correct startup time is set.
3. Wait 5 seconds. Preset starting time is stored and day of week flashes.
4. Press button (8) or (9) to select the correct startup day of week.
5. Wait 5 seconds. The startup day of week is stored.

The number of memory location remains on the display. The timer is now in the programmed mode and will switch the heater in a the preset time.

**Note:** *We recommend that memory locations 1 and 2 be used for presetting times within 24 hours of setting the timer. Memory location 3 can be used for a starting time within the next 7 days of setting the timer.*

### Recalling Preset Times

Press (6) repeatedly until the desired memory location number and preset time are displayed.

### Canceling Preset Time

Press button (6) repeatedly until no more memory location number is visible on the display.

### Setting Operating Time

1. With heater off, press button (8). Operating time flashes.

2. Press button (8) or (9) to set the operating time (between 1 and 120 minutes).

3. Wait 5 seconds. Operating time is stored.

The heater remains in operation for the preset time (except for continuous operation).

### Setting the Remaining Operating Time

1. With heater in operation, press button (8). Remaining operating time flashes.
2. Set remaining time with button (8) or (9).
3. Wait 5 seconds. Remaining operating time is stored.

### Fault Diagnosis by Coded Light Signals

On heaters equipped with a fault diagnosis system using coded light signals, the equipment-on indicator/operation indicator flashes. Please consult your Webasto dealer.

## 13.3 TROUBLESHOOTING AND MAINTENANCE

Refer to the Webasto manual for more information.

**Note:** *If there are no heater faults, the heater will go through a normal start cycle and regulate based on thermostat setting.*

**Note:** *Switch on the preheating system briefly about once a month, even during the warm season.*

**Caution:** *When welding on the vehicle, disconnect the preheater module connector in order to protect this system from voltage surges.*

**Caution:** *To avoid running down the batteries, do not turn on the preheating system for more than one hour before starting the engine.*

**Warning:** *The preheating system uses the same fuel as the engine. Do not operate in a building or while refueling. Operate only in a well-ventilated area.*

**14. SPECIFICATIONS**

**Main evaporator motor**

Make.....US MOTOR  
 Type .....T-17  
 Voltage ..... 27.5 V DC  
 Current draw ..... 68 amps  
 Horsepower..... 2  
 Revolution ..... 1400 & 1800 rpm  
 Insulation .....Class F  
 Motor Life .....20 000 hours  
 Brush life ..... 10 000 hours  
 Motor supplier number ..... D5092VPRC8  
 Motor Prevost number..... 563008  
 Brush supplier number .....EPB125BC0077  
 Brush Prevost number ..... 562951

**Condenser fan motors**

Make.....US MOTOR  
 Type ..... TF-12  
 Voltage ..... 28.5 V DC  
 Current draw ..... 25 amps  
 Horsepower ..... 0.57  
 Revolution ..... 1950 rpm  
 Insulation .....Class F  
 Motor .....20 000 hours  
 Brush life ..... 10 000 hours  
 Qty..... 2  
 Supplier number ..... D591Y440PRC2  
 Prevost number ..... 562579  
 Brush supplier number ..... 9DB21003  
 Brush Prevost number ..... 561914

**Section 22: HEATING AND AIR CONDITIONING**

---

**Main evaporator air filter**

Make..... Permatron Corp.  
Type ..... Washable 1" X 23 3/8" X 43 1/2" Polypropylene filter  
Supplier number ..... MODEL IN-1  
Prevost number ..... 871051

**Driver's unit evaporator motors**

Make..... MCC  
Voltage ..... 24 V DC  
Quantity ..... 1  
Supplier number ..... 25-0250  
Prevost number ..... 871135

**Driver's unit evaporator air filter**

Make..... MCC  
TYPE ..... Recirculating air 6-1/4" x 28" Washable  
Supplier number ..... 260593  
Prevost number ..... 871147

Make..... MCC  
TYPE ..... Fresh air 3-5/8" X 5-1/4" Washable  
Supplier number ..... 260594  
Prevost number ..... 871144

**Refrigerant**

Type ..... Optional R-22 and Standard R-134a  
Quantity (standard) ..... 24 lbs (10.89 Kg)  
Quantity (with A/C unities Parcel Rack) ..... 26 lbs (11.82 Kg)

**Compressor (Central system)**

Make..... Carrier Transicold  
Capacity, option R-134a ..... 41 CFM  
Capacity, option R-22 ..... 37 CFM  
Model, option R-134 ..... 05G-134A  
Model, option R-22 ..... 05G-22

## Section 22: HEATING AND AIR CONDITIONING

No. of cylinders ..... 6  
Bore..... 2" (50,8 mm)  
Operating speed.....400 to 2200 rpm (1750 rpm. Nominal)  
Minimum speed (for lubrication)..... 400 rpm  
Nominal horsepower ..... 15  
Oil pressure at 1750 rpm ..... 15 to 30 psi (103-207 kPa)  
Oil capacity..... 1.13 U.S. gal (4,3 liters)  
Weight ..... 142 lbs (64,5 kg)  
Approved oils  
-Castrol..... SW 68 (POE)  
Supplier number, option R-134a ..... 68PD541-104-38  
Supplier number, option R-22 ..... 68PD537-104-39  
Prevost number, option R-134a ..... 950314  
Prevost number, option R-22 ..... 950207

### **A/C Compressor (Small system)**

Make.....Selte  
c  
Model.....TM-  
16HD  
Weight ..... 10.9 lbs (4,9 kg)  
Supplier number .....18-00074-11  
Prevost number ..... 950372  
Approved oil ..... ZXL100PG (PAG)  
Prevost number ..... 950382

### **Compressor unloader valve**

Make..... Carrier Transicold  
Type ..... Electric (AMC)  
Voltage ..... 24 V DC)  
Watts ..... 15  
Supplier number (without coil) ..... 17-40407-20  
Prevost number (without coil) ..... 950095  
Coil supplier number ..... 22-50030 (1)  
Coil Prevost numbert..... 950096

**Section 22: HEATING AND AIR CONDITIONING**

---

**Magnetic clutch**

Make..... Carrier Transicold  
Type ..... Housing mounted 9" dia., 2-B grooves  
Voltage ..... 24 V DC  
Coil resistance at 68 °F (20 °C)..... 5.15 – 5.69 ohms  
Supplier number ..... 50-01122-90  
Prevost number ..... 950204

**Compressor V belts**

Make..... Dayco  
Model (matching set of 2) ..... BX97  
Prevost number (with Delco 270/300 Amp Alternator) ..... 506664

**Compressor V belt**

Make..... Dayco  
Model..... BX100  
Prevost number (with two BOSH Alternators) ..... 506681

**Condenser coil**

Make..... Carrier Transicold  
Aluminium  
Supplier number ..... 68BC-509-114  
Prevost number ..... 452968  
Copper  
Supplier number ..... 68BC-509---104-1  
Prevost number ..... 453013

**Receiver tank (with sight glasses)**

Make..... HENRY  
Maximum pressure..... 450 psig  
Supplier number ..... ARL-1217  
Prevost number ..... 950261

**Filter Dryer assembly**

Make..... AC&R HENRY

**Section 22: HEATING AND AIR CONDITIONING**

Supplier number .....815031-XH9

Prevost number ..... 950262

**Moisture indicator**

Make..... Henry

Supplier number ..... MI-30-7/8S

Prevost number ..... 950029

**Driver's refrigerant liquid solenoid valve**

Make..... Parker

Type ..... Normally closed with manual bypass

Voltage ..... 24 V DC

Amperage draw ..... 0.67 amps

Watts ..... 16

Supplier number (without coil) ..... RB9MP3-MM

Prevost number (without coil) ..... 95-0054

Coil supplier number ..... R23MM 24 V DC-CB

Coil Prevost number..... 950055

Repair kit Prevost number ..... 950056

**Driver's hot water solenoid valve**

Make..... Asco

Type ..... Normally open (without manual bypass)

Voltage ..... 24 V DC

Current draw ..... 0.47 amp.

Watts ..... 11.2

Pressure range..... 0 to 100 psi

Max. temperature .....220°F

Supplier number (with coil) .....106-269-1

Prevost number (with coil) ..... 870812

Coil Prevost number..... 870960

Repair kit Prevost number ..... 870872

**Main hot water valve actuator**

Make..... Honeywell

Model..... ML 784

Voltage ..... 24 V DC

## Section 22: HEATING AND AIR CONDITIONING

---

Type ..... Linear  
Prevost number ..... 641238  
Supplier number ..... ML784A207a  
Repair kit Prevost number (packing, follower, spring stem assembly and disc) ..... 641261  
Repair kit supplier number ..... 14 00 2695-005

### Single-seated valve

Model ..... V5011F  
Prevost number ..... 641239

### Water recirculating pump

Make ..... M.P. pumps  
Voltage ..... 24 V DC  
Supplier number ..... 28689  
Prevost number ..... 871052

### Water filter (standard system)

Make ..... Parker  
Supplier number (with element) ..... 15CN1238WP  
Prevost number (with element) ..... 871028  
Element supplier number ..... 925566  
Element Prevost number ..... 871029

### Water filter (small A/C system)

Make ..... BRAUKMANN  
Supplier number ..... T300B  
Prevost number ..... 870807

### Driver's expansion valve

Supplier number, option R-134a ..... 26-0190  
Supplier number, option R-22 ..... 26-0384  
Prevost number, option R-134a ..... 950221  
Prevost number, option R-22 ..... 950282

### Main expansion valve (with R-134A)

Make ..... CARRIER  
Supplier number ..... 14-01104-43  
Prevost number ..... 95316

### Main expansion valve (with R-22 option)



**Section 22: HEATING AND AIR CONDITIONING**

---

Make..... ALCO  
Supplier number..... TCLE 10HW55  
Prevost number..... 950292

**Bypass solenoid water valve**

Make..... Parker Hanninfin  
Bypass supplier number ..... RB21ME7-MM  
Bypass Prevost number ..... 870886  
Coil supplier number ..... R-23MM24VDC-CB  
Coil Prevost number..... 870886  
Repair kit supplier number ..... 76754  
Repair kit Prevost number ..... 870980

**Preheating system**

Make..... WEBASTO  
Model..... THERMO 300  
Capacity ..... 104 000 Btu/h (30 kW)  
Heating medium ..... Coolant  
Rated voltage ..... 24 V DC  
Operating voltage..... 20-28 V DC  
Electric power consumption (without coolant recirc. Pump)..... 110 watts  
Fuel consumption..... 1,2 US gallons/hr (4,5 liters/hr)  
Supplier number..... 9002092A  
Prevost number..... 871202