

SECTION 26: VIP SLIDE-OUT

CONTENTS

1. SLIDE-OUT	26-6
1.1 INNER STOPPER.....	26-6
1.1.1 Maintenance.....	26-6
1.1.2 Adjustment.....	26-6
1.2 EXTERIOR EXTRUSION.....	26-7
1.2.1 Maintenance.....	26-7
1.3 FRONT SLIDE-OUT REMOVAL.....	26-7
1.4 FRONT SLIDE-OUT INSTALLATION.....	26-8
1.5 REAR SLIDE-OUT REMOVAL.....	26-9
1.6 REAR SLIDE-OUT INSTALLATION.....	26-9
2. LOCKING PIN	26-9
2.1 MAINTENANCE.....	26-10
2.2 ADJUSTMENT.....	26-10
2.3 REPLACEMENT.....	26-11
2.4 SENSOR SWITCH ADJUSTMENT.....	26-11
2.5 PIN RECEPTACLE.....	26-12
2.5.1 Maintenance.....	26-12
2.5.2 Replacement.....	26-12
3. ROOF REINFORCING ROD	26-13
4. RACK	26-13
4.1 MAINTENANCE.....	26-13
4.2 UPPER RACK REPLACEMENT ON BOTH SLIDE-OUT.....	26-13
4.3 FRONT SLIDE-OUT LOWER RACK REPLACEMENT.....	26-14
4.4 REAR SLIDE-OUT LOWER RACK REPLACEMENT.....	26-14
5. PINION	26-14
5.1 MAINTENANCE.....	26-15
5.2 UPPER SHAFT PINION REPLACEMENT.....	26-15
5.3 FRONT SLIDE-OUT DRIVER SIDE LOWER SHAFT PINION REPLACEMENT.....	26-15
5.4 FRONT SLIDE-OUT MOTOR SIDE LOWER SHAFT PINION REPLACEMENT.....	26-16
5.5 REAR SLIDE-OUT LOWER SHAFT PINION REPLACEMENT.....	26-16
5.6 PINION SYNCHRONIZATION.....	26-17
5.7 GUIDE WHEEL.....	26-18
5.8 PLASTIC STOPPER.....	26-18
6. ELECTRIC MOTOR	26-18
6.1 MAINTENANCE.....	26-18
6.2 REPLACEMENT.....	26-18
7. SPEED REDUCTION GEARBOX	26-19
7.1 MAINTENANCE.....	26-19
7.2 GEARBOX REPLACEMENT.....	26-19
8. RIGHT ANGLE DRIVE	26-20
8.1 MAINTENANCE.....	26-20
8.2 LOWER SHAFT RIGHT ANGLE DRIVE REPLACEMENT.....	26-20
8.3 UPPER SHAFT RIGHT ANGLE DRIVE REPLACEMENT.....	26-20
9. JAW COUPLING	26-20

Section 26: VIP SLIDE-OUT

9.1 MAINTENANCE	26-20
9.2 REPLACEMENT	26-21
10.UHMW SLIDING PAD	26-21
10.1 MAINTENANCE	26-21
10.2 REPLACEMENT & ADJUSTMENT	26-21
11.VERTICAL SHAFT AND UNIVERSAL JOINT ASSEMBLY	26-21
11.1 MAINTENANCE	26-21
11.2 UNIVERSAL JOINT REPLACEMENT	26-21
11.3 VERTICAL SHAFT REPLACEMENT	26-22
12.SLIDE-OUT PNEUMATIC SYSTEM	26-22
12.1 DESCRIPTION	26-22
12.2 PNEUMATIC INTERCONNECTION WITH PREVOST VEHICLE	26-23
12.3 MAINTENANCE	26-23
12.4 SEAL	26-23
12.4.1 Maintenance	26-24
12.4.2 Seal assembly removal	26-24
12.4.3 Seal assembly installation	26-24
12.4.4 Slide-out 2" inside retraction	26-25
13.SLIDE-OUT ELECTRICAL SYSTEM	26-26
13.1 ELECTRICAL INTERCONNECTION WITH PREVOST VEHICLE	26-26
13.2 SLIDE-OUT BREAKERS/FUSE	26-26
13.3 ELECTRONIC CONTROLLERS	26-27
13.3.1 Motor controller replacement	26-28
13.3.2 Logic controller replacement	26-30
13.3.3 Safety controller replacement	26-30
13.3.4 Downloading program	26-30
13.4 SLIDE-OUT POSITION SENSOR	26-31
13.4.1 Maintenance and adjustment	26-31
14.SLIDE-OUT EXTERIOR FINISHING PANELS	26-32
14.1 SIDE PANEL REMOVAL	26-32
14.2 SIDE PANEL INSTALLATION	26-32
14.3 CORNER PANELS REMOVAL	26-32
14.4 CORNER PANELS INSTALLATION	26-33
14.5 TOP AND BOTTOM PANELS REMOVAL	26-33
14.6 TOP AND BOTTOM PANELS INSTALLATION	26-34
15.SLIDE-OUT FIXED, AWNING AND SLIDING WINDOWS	26-34
15.1 WINDOWS REMOVAL	26-34
15.2 WINDOWS INSTALLATION	26-35
16.WELDING PRECAUTION	26-35
17.TROUBLESHOOTING	26-40
17.1 SLIDE-OUT CONTROL SWITCH AND TELLTALE LIGHT ON VEHICLE DASHBOARD	26-40
17.2 MOTOR CONTROLLER	26-43
17.3 SLIDE-OUT OPERATION	26-45

18.SPECIFICATIONS.....	26-47
18.1 SLIDE-OUT MAXIMUM LOAD	26-47
18.2 TRANTORQUE KEYLESS BUSHING	26-47
18.3 SPEED REDUCTION GEARBOX	26-49
18.4 POSITION SENSORS.....	26-49
18.5 RIGHT ANGLE DRIVE	26-49
18.6 ELECTRIC MOTOR	26-49
18.7 LOGIC CONTROLLER.....	26-49
18.8 MOTOR CONTROLLER	26-49
18.9 ELECTRICAL CONTROL SWITCH.....	26-50
18.10 CONVERSION CHECKLIST	26-50

LIST OF ILLUSTRATIONS

FIGURE 1 : SLIDE-OUT MECHANICAL COMPONENTS	26-5
FIGURE 2 : FRONT SLIDE-OUT.....	26-6
FIGURE 3 : REAR SLIDE-OUT	26-6
FIGURE 4 : SIDE INNER STOPPER.....	26-6
FIGURE 5 : UPPER STOPPERS	26-6
FIGURE 6 : EXTERIOR EXTRUSION.....	26-7
FIGURE 7 : EXTERIOR PANEL EDGE	26-7
FIGURE 8 : UPPER SHAFT PILLOW BLOCK	26-7
FIGURE 9: SLIDE-OUT POSITION SENSORS PROTECTOR	26-8
FIGURE 10 : GUIDE WHEEL TRACK	26-9
FIGURE 11 : REAR SLIDE-OUT BED ROLLER	26-9
FIGURE 12 : LOCKING PIN MECHANISM.....	26-10
FIGURE 13 : LOCKING PIN INSTALLATION.....	26-11
FIGURE 14 : SENSOR SWITCH ADJUSTMENT	26-11
FIGURE 15 : PIN RECEPTACLE INSTALLATION.....	26-12
FIGURE 16 : PIN RECEPTACLE ON GLASS	26-12
FIGURE 17 : PIN RECEPTACLE ON STAINLESS STEEL PANELS	26-13
FIGURE 18 : FRONT SLIDE-OUT ROOF REINFORCING ROD	26-13
FIGURE 19 : BOTTOM RACK.....	26-13
FIGURE 20 : PILLOW BLOCK SUPPORTING PLATE	26-16
FIGURE 21 : KEYLESS BUSHING TIGHTENING	26-17
FIGURE 22 : TORQUE WRENCH FORMULA.....	26-17
FIGURE 23 : SLIDE-OUT ADJUSTABLE SHAFT ASSEMBLY	26-18
FIGURE 24 : ELECTRIC MOTOR	26-18
FIGURE 25 : FRONT SLIDE-OUT MOTOR ASSEMBLY.....	26-19
FIGURE 26 : REAR SLIDE-OUT MOTOR ASSEMBLY	26-19
FIGURE 27 : FRONT SLIDE-OUT SLIDING PAD LEVELLING	26-20
FIGURE 28 : REAR SLIDE-OUT SLIDING PAD LEVELLING.....	26-21
FIGURE 29 : TAG AXLE VALVE.....	26-22
FIGURE 30 : FRONT SERVICE COMPARTMENT	26-23
FIGURE 31 : SEAL ASSEMBLY	26-24
FIGURE 32 : FRONT SLIDE-OUT INFLATABLE SEAL AIR INLET	26-24
FIGURE 33 : REAR SLIDE-OUT INFLATABLE SEAL AIR INLET	26-24
FIGURE 34 : SLIDE-OUT 2" INSIDE – UPPER PART.....	26-25
FIGURE 35 : DASHBOARD SLIDE-OUT TELLTALE LIGHT	26-26
FIGURE 36 : BREAKERS IN MAIN POWER COMPARTMENT	26-26
FIGURE 37 : INSIDE MAIN POWER COMPARTMENT.....	26-27
FIGURE 38 : SLIDE-OUT ELECTRICAL PANEL (SMALL A/C).....	26-28
FIGURE 39 : SLIDE-OUT ELECTRICAL PANEL (FULL A/C)	26-28
FIGURE 40 : MOTOR CONTROLLER LED PANEL	26-29
FIGURE 41 : SLIDE-OUT BREAKERS.....	26-29

Section 26: VIP SLIDE-OUT

FIGURE 42 : FRONT SLIDE-OUT SENSORS.....	26-31
FIGURE 43 : REAR SLIDE-OUT SENSORS	26-31
FIGURE 44 : MAGNETS ON SLIDE-OUT UNDERBODY	26-31
FIGURE 45 : SLIDE-OUT PANELS AND WINDOWS.....	26-32
FIGURE 46 : CORNER PANEL INSTALLATION – UPPER PART.....	26-33
FIGURE 47 : CORNER PANEL INSTALLATION – LOWER PART	26-33
FIGURE 48 : TOP AND BOTTOM PANEL INSTALLATION	26-34
FIGURE 49 : TOP PANEL INSTALLATION	26-34
FIGURE 50 : WINDOWS ABOVE SIDE PANELS.....	26-35
FIGURE 51 : WINDOW LOCATED OVER THE CORNER PANEL.....	26-35
FIGURE 52 : PINION & PILLOW BLOCK ADJUSTMENT, REAR SLIDE-OUT	26-36
FIGURE 53 : PINION & PILLOW BLOCK ADJUSTMENT, FRONT SLIDE-OUT	26-36
FIGURE 54 : PNEUMATIC COMPONENT PANEL	26-37
FIGURE 55 : SLIDE-OUT LOGIC CONTROLLER LED PANEL	26-38
FIGURE 56 : LOCKING PIN ASSEMBLY	26-39
FIGURE 57 : FRONT SLIDE-OUT DEFLECTION	26-47
FIGURE 58 : WRENCHES FOR KEYLESS BUSHING INSTALLATION	26-47
FIGURE 59 : KEYLESS BUSHING INSTALLATION INSTRUCTION	26-48

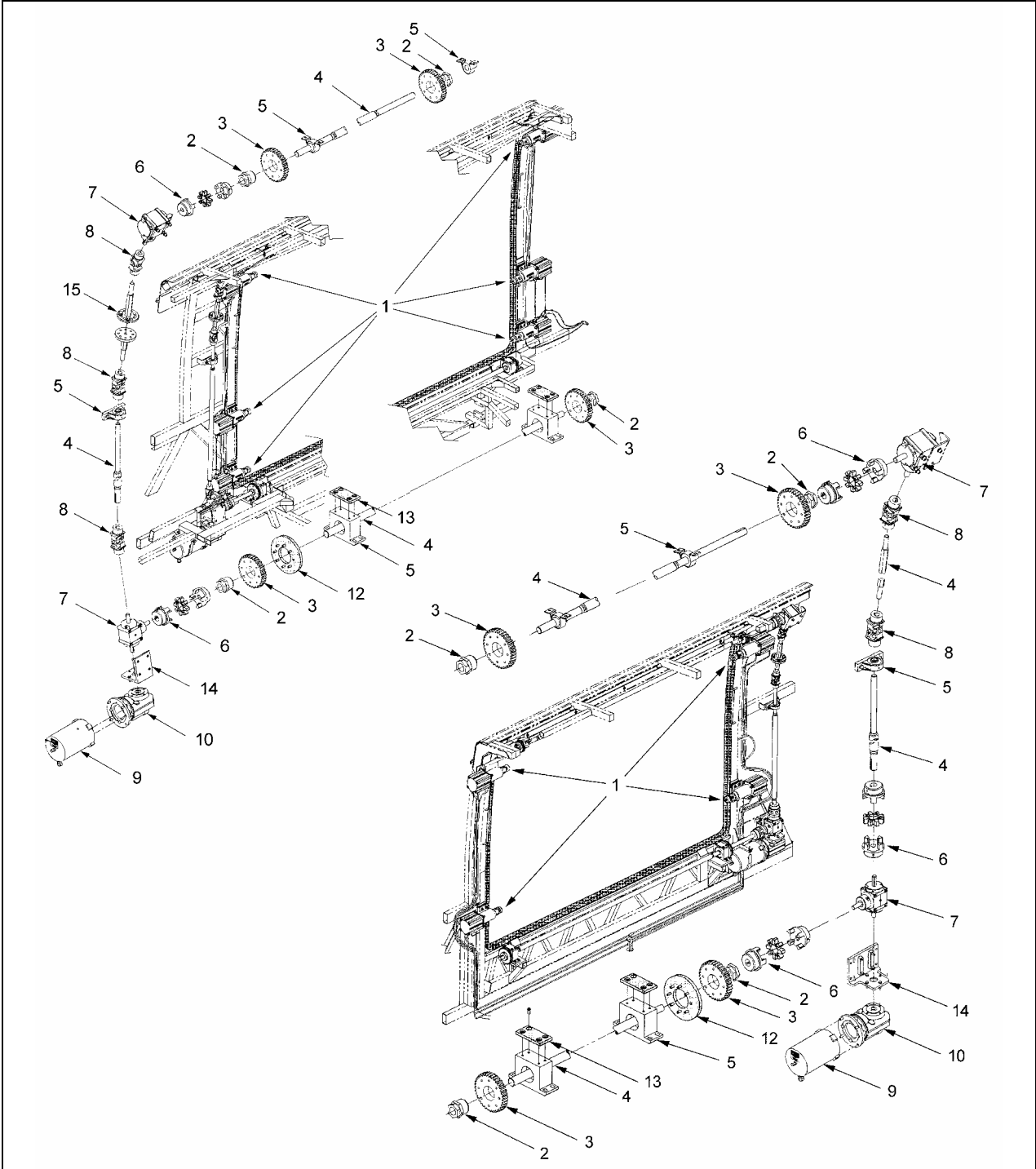

FIGURE 1 : SLIDE-OUT MECHANICAL COMPONENTS

- | | | |
|--------------------|--------------------|---------------------------|
| 1- LOCKING PIN | 6- JAW COUPLING | 12- GUIDE WHEEL |
| 2- KEYLESS BUSHING | 7- RIGHT ANGLE | 13- UHMW SLIDING PAD |
| 3- PINION | 8- UNIVERSAL JOINT | 14- GEARBOX SUPPORT |
| 4- SHAFT | 9- ELECTRIC MOTOR | 15- ADJUSTABLE SHAFT ASSY |
| 5- PILLOW BLOCK | 10- GEARBOX | |

1. SLIDE-OUT

1.1 INNER STOPPER

The front slide-out is equipped with six inner stoppers laid out in the following way: two stoppers on the top horizontal member of the slide-out, and two stoppers on each vertical upright, while the rear slide-out is equipped with only three stoppers (figure 2 and figure 3). These stoppers are used to block the extension of the slide-out, and to provide a support to position perpendicularly the slide-out with the vehicle structure. It is thus of primary importance that the stoppers remain on the slide-out for the automatic operation. If not, nothing will stop the slide-out during its extension.

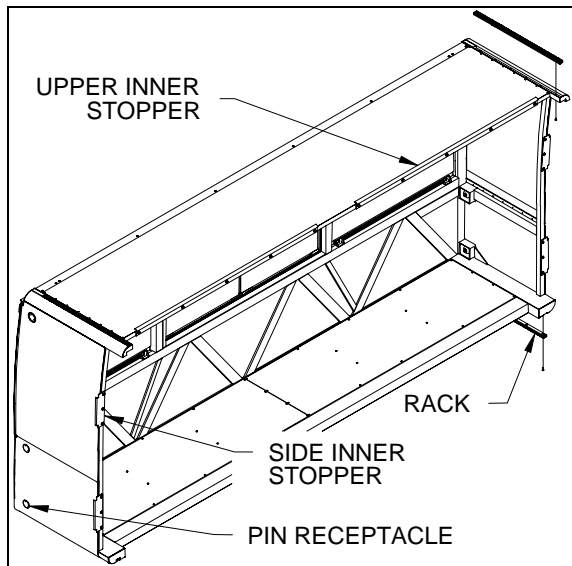

FIGURE 2 : FRONT SLIDE-OUT

1.1.1 Maintenance

Check that the inner stopper screws are tight and that no damage or deformation has taken place for both the side and the upper stoppers.

1.1.2 Adjustment

1. Adjust the side inner stoppers at 1/8" from the vehicle structure stoppers, and tighten the screws (figure 4).
2. Adjust the upper structure stopper at 1/4" from the slide-out structure and tighten the screws (figure 5).

3. Adjust the slide-out inner upper stoppers so they rest on structure stopper when the slide-out is extended (figure 6), and tighten the screws.

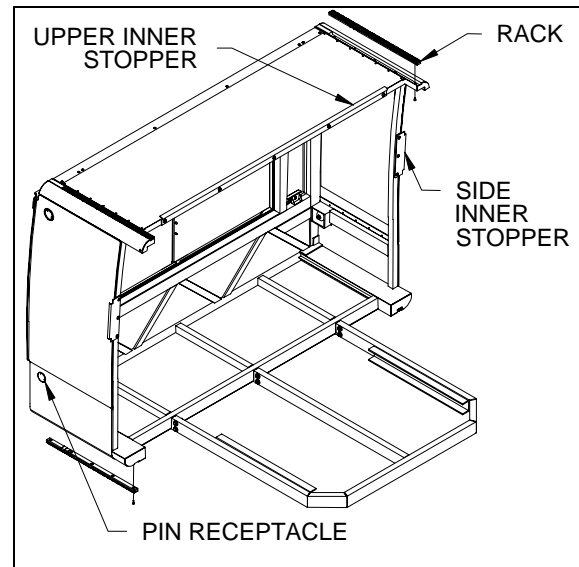

FIGURE 3 : REAR SLIDE-OUT

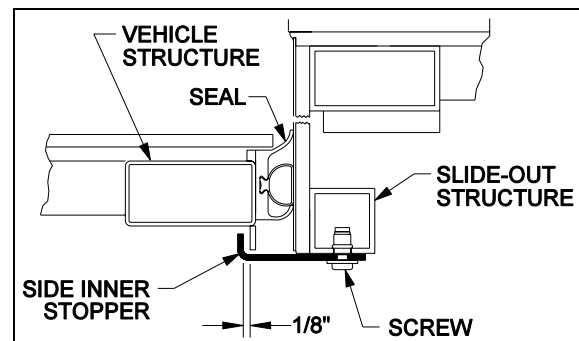

FIGURE 4 : SIDE INNER STOPPER

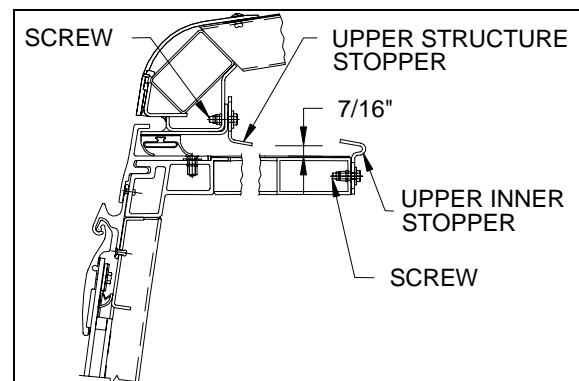

FIGURE 5 : UPPER STOPPERS

1.2 EXTERIOR EXTRUSION

The exterior extrusion function is to provide a leaning surface for the inflatable seal. When inflating, the seal leans against the extrusion and presses the roof structure upward until it rests on the inner side of the extrusion. This is to hold back the roof structure (figure 5 and figure 6).

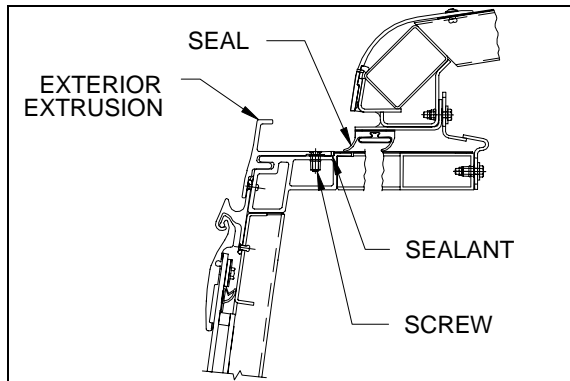

FIGURE 6 : EXTERIOR EXTRUSION

1.2.1 Maintenance

Inspect the exterior extrusion for any deformation or deterioration. Check that the screws are tight. Inspect the sealant condition on screw head and between the extrusion and the vehicle structure, and also at both ends of the extrusion. If needed, clean old sealant and replace with Sika 221 sealant or equivalent product.

1.3 FRONT SLIDE-OUT REMOVAL

1. Deflate the air seal completely to prevent any damage (see the slide-out operation manual).
2. Using the slide-out control switch and/or the manual override procedure, move the slide-out to its fully extended position.

Caution: Ensure suspension stabilization before using the height adjustable tables to prevent any damage to the vehicle or slide-out structure.

3. Support each end of the slide-out with height adjustable tables. Use plywood panels covered with soft material, such as carpet, to prevent any damage to the slide-out under panels and the exterior panel edge (figure 7). The supporting tables should not obstruct the slide-out bottom racks. Rise up the tables to support the slide-out without lifting it.

4. From inside the vehicle, loosen the upper shaft pillow block nuts and remove the shims behind the pillow blocks. Keep note of the shims position (figure 8).
5. Using the manual override procedure (see the operation manual), retract the slide-out a few inches to disengage the slide-out from its inner stoppers.

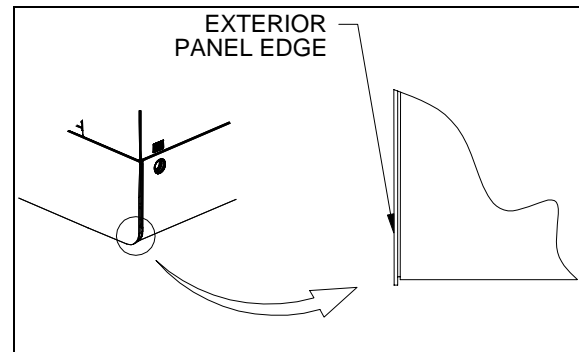

FIGURE 7 : EXTERIOR PANEL EDGE

Warning: The inner stoppers are used to stop and straighten the slide-out. The motor drive is controlled in overcurrent for three seconds after reaching its fully extended position. Never use the automatic control without the inner stoppers. The slide-out could fall down and cause serious damage and/or injury.

6. Unscrew and remove the slide-out inner upper and side stoppers. Loosen the upper structure stopper retaining screws and move this stopper to the upward position to allow the slide-out to come out freely (figure 5).

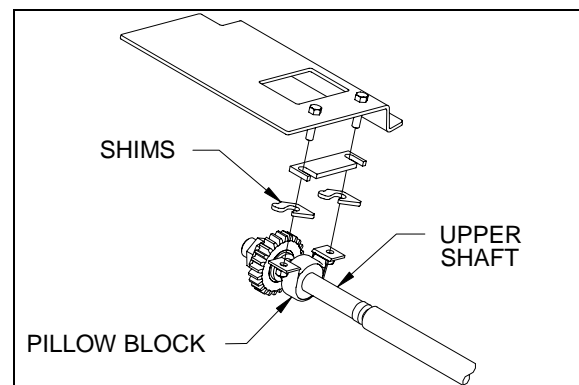

FIGURE 8 : UPPER SHAFT PILLOW BLOCK

7. Unscrew and remove the position sensors protector (figure 9).
8. Disengage both upper and lower shaft jaw couplings (figure 1 item 6).

Section 26: VIP SLIDE-OUT

9. Push the upper shaft to its highest position to allow the slide-out to be removed freely.

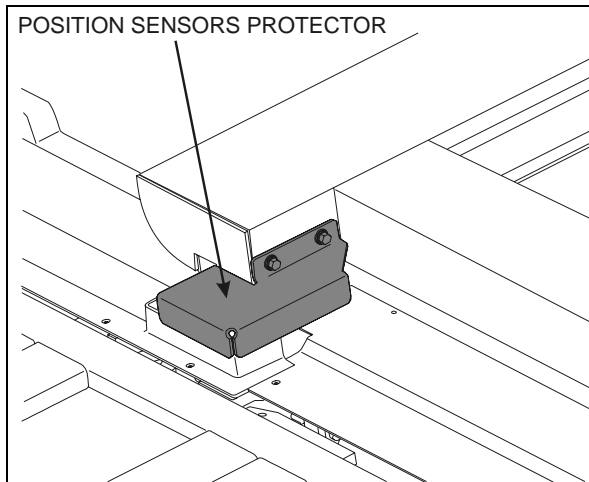

FIGURE 9: SLIDE-OUT POSITION SENSORS PROTECTOR

Caution: Be careful when moving the slide-out to prevent any damage to the slide-out itself and/or its seal. When moving the slide-out, check constantly its four corners from inside and outside the vehicle to avoid contact with the locking pins and/or the vehicle structure.

10. Slightly lift the slide-out and move it outside the vehicle on the supporting tables.
11. Take advantage of the situation to inspect internal mechanical components, UHMW sliding pads (section 10) and seal condition.

1.4 FRONT SLIDE-OUT INSTALLATION

Before proceeding with the front slide-out installation, check the following conditions:

- The air seal is completely deflated;
- The upper driving shaft pillow blocks are loose;
- The upper and lower shaft jaw couplings are disengaged;
- The upper and lower shaft keyless bushings located on the driver side are tight;
- The upper and lower shaft keyless bushings located on the motor side are free.

Note: The lower shaft keyless bushing located near the driver seat is not accessible unless the slide-out is removed completely from the vehicle, and does not need to be loosened.

Caution: Ensure suspension stabilization before using the height adjustable tables to prevent any damage to the vehicle or slide-out structure.

1. Using height adjustable tables, raise the slide-out and center it with the vehicle opening.

Caution: Be careful when moving the slide-out to prevent any damage to the slide-out itself and/or its seal. When moving the slide-out, check constantly its four corners from inside and outside to avoid contact with the locking pins and/or the vehicle structure.

2. Bring the slide-out close to the vehicle opening. Check from inside and outside that the four corners do not touch the vehicle structure.
3. Carefully put the slide-out on its UHMW sliding pads and the racks on their pinions (figure 1 item 3 and 13). Slide the free pinions to center them on their racks. Also, make sure that the guide wheel is in its track (figure 10 and figure 1 item 12).

Caution: Put soft material, such as carpet, on the floor of the vehicle in line with the lower racks to prevent slide-out contact when it will be pushed inside.

4. Slowly push the slide-out inside the vehicle keeping it straight. When the slide-out is well seated on its racks and pinions, hold it firmly to prevent it from falling outside or inside the vehicle, and remove the supporting tables. Push the slide-out inside and align the receptacles with the locking pins.

Caution: The slide-out receptacles must be perfectly aligned with the locking pins before locking them.

5. Using a compressed air nozzle, lock the pins one by one.

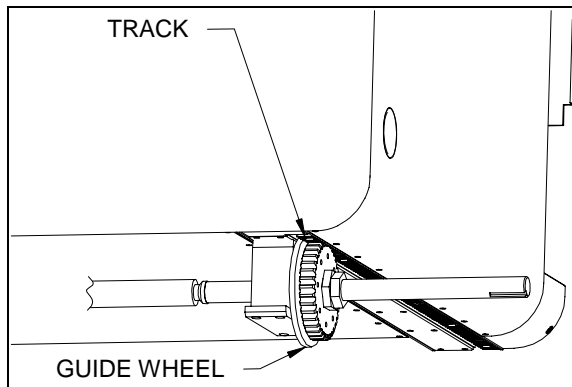

FIGURE 10 : GUIDE WHEEL TRACK

6. Reinstall the upper shaft pillow block shims in their original location (figure 8). Add or remove shims to leave no clearance between the pinion and the rack. Tighten the pillow block nuts.
7. Re-engage respectively the upper and lower shaft jaw couplings (figure 1 item 6). If necessary, realign the right angle drive (see section 8).
8. Tighten and synchronize the upper and lower shaft pinion as described in section 5.6.
9. Reinstall the slide-out side inner stoppers (section 1.1).

Caution: Make sure all keyless bushings are tightened to 125 lb-ft before unlocking the pins or moving the slide-out. Refer to section 5.6 for torque wrench settings.

10. Using a compressed air nozzle, manually unlock the pins.
11. Using the manual procedure, extend the slide-out until its interior stoppers come close to the vehicle structure for adjustment.
12. Adjust the slide-out stoppers as described in section 1.1.2.
13. Reinstall the position sensors protector.
14. Re-inflate the inflatable seal at 10 psi (see operating manual).

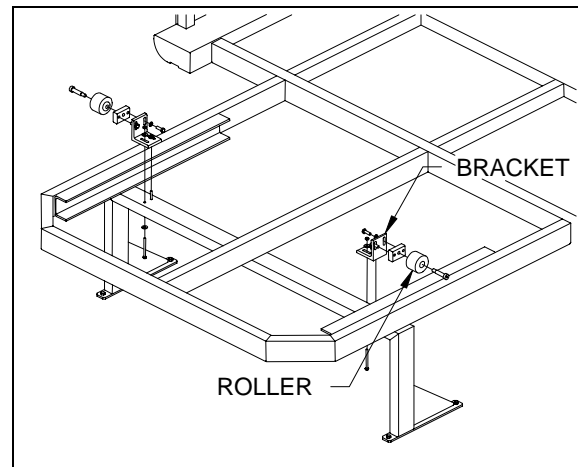

FIGURE 11 : REAR SLIDE-OUT BED ROLLER

1.5 REAR SLIDE-OUT REMOVAL

The rear slide-out removing procedure is almost the same as the procedure for the front slide-out. The only difference is the removal of the two rollers from the bed structure (figure 11), which must be done before step 9 of procedure 1.3.

1.6 REAR SLIDE-OUT INSTALLATION

The procedure for installing the rear slide-out is almost the same as the procedure for the front slide-out. Do not forget, the bed rollers must be reinstalled (figure 11).

2. LOCKING PIN

The locking pin system is used to lock the slide-out when in retracted position and link it with vehicle structure. This is to restore the vehicle structure integrity. This system consists of pneumatic cylinders connected to shafts with variable diameters which move segments located into a sleeve (see figure 12). During the extension of the cylinder, the sleeve penetrates partly into the slide-out receptacle to lock the slide-out. Then, the segments come to immobilize the part of the sleeve in the receptacle and also in the locking pin. Sensors installed on cylinders send a signal to a logic controller to indicate if the cylinder is in locked or unlocked position.

Section 26: VIP SLIDE-OUT

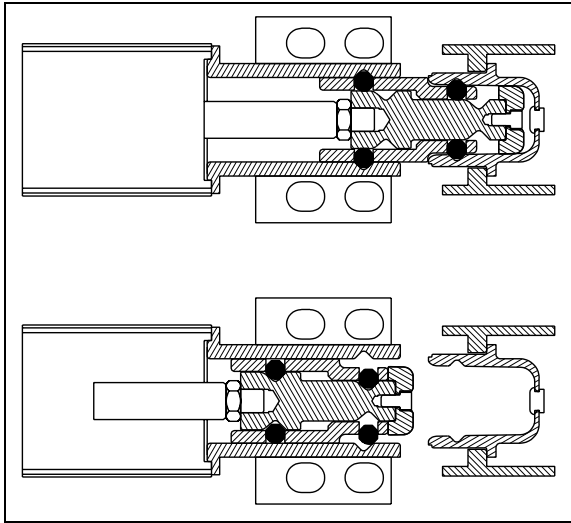

FIGURE 12 : LOCKING PIN MECHANISM

Note: The locking pin system optimal air pressure is 90 psi. Below 70 psi, pins may not lock or unlock completely.

2.1 MAINTENANCE

Caution: The locking pins may have to be adjusted after a load variation in the vehicle and/or the slide-out.

A load variation in the vehicle and/or the slide-out (ex: after the conversion) may affect structure deflection, therefore the locking pin adjustment, especially for the front slide-out.

After conversion process and twice a year, inspect the locking pins proper movement by manually activating the pins a few times when the slide-out is retracted. Check the inputs LED on each logic controller panel when activating the pins manually. Refer to LED description table (see figure 55).

A locking pin problem may be suspected if an error code is detected on the control switch. This probably means that a locking pin is not aligned or defective, and must be readjusted or fixed. Remove and disassemble the pin mechanism if a malfunction is suspected. Inspect the head, sleeve and segment for wear, deformation or rust, and replace defective parts (see figure 56).

A knocking sound may be heard when locking or unlocking the pins. This is normal because of the pneumatic system.

Inspect the locking pin cylinder and the fittings for air leaks. In case a locking pin refuses to

lock, check the inlet reducer fitting on the pin side cylinder port for any particle that would cause airflow restriction

2.2 ADJUSTMENT

1. The slide-out must be retracted and all the pins locked for pin adjustment.
2. Deflate the air seal completely to prevent any damage (see the slide-out operation manual).
3. **Front slide-out only:** Unload the tag axle using the manual switch located on the left-hand control panel, while the ignition key is switched to the "ON" position. When the tag axle is unloaded, switch the ignition to the "OFF" position.
4. Loosen the locking pin nuts.
5. Align the locking pin with the slide-out receptacle by putting shims between the locking pin base and the vehicle structure (figure 13). The shims must be inserted with a sliding fit. Make sure to put as many shims on the upper studs as on the lower studs to keep the locking pin base parallel to the vehicle structure.
6. Align horizontally the locking pin in the slide-out receptacle and tighten the four nuts.

Caution: The locking pin and the slide-out receptacle must be aligned before locking the pin. A locking pin not aligned with its receptacle may seriously damage the slide-out panels or windows.

7. Using a compressed air nozzle, lock and unlock manually a few times the locking pin to check that it does not knock. If it does, correct the alignment repeating step 2 to step 5. Make sure that the locking pin does not force the slide-out to move during all the procedure.
8. Make a final check by activating a few times manually (using compressed air) the locking pin to be sure of a perfect alignment.
9. Tighten the four locking pin nuts to 45 lb-ft.
10. Re-inflate the inflatable seal at 10 psi.

2.3 REPLACEMENT

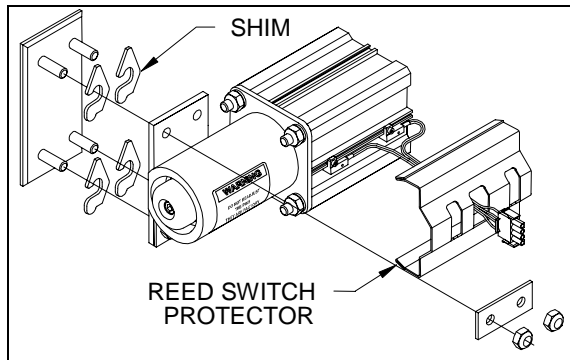

FIGURE 13 : LOCKING PIN INSTALLATION

1. The slide-out must be retracted and all pins locked for pin adjustment.
 2. Deflate the inflatable seal completely to prevent any damage.
 3. **Front slide-out only:** Unload the tag axle using the manual switch located on the left-hand control panel, while the ignition key is switched to the "ON" position. When the tag axle is unloaded, switch the ignition to the "OFF" position.
 4. Note the pneumatic tubing position, then disconnect the tubing and the electric cable from the locking pin assembly (figure 13).
 5. Using a compressed air nozzle, unlock the pin mechanism.
 6. Remove the sensor switches. Unscrew and remove the locking pin unit. Keep the shims for further installation (figure 13).
- Note:** Adjust the locking pin sensor switch before installing the pin on the vehicle (refer to section 2.4).
7. Install the new locking pin on its support keeping it loose and lock it manually.
 8. Adjust the locking pin as described in section 2.2.
 9. Re-connect the tubing and the sensor switch electrical cable.
 10. Re-inflate the inflatable seal at 10 psi.

2.4 SENSOR SWITCH ADJUSTMENT

1. Using a compressed air nozzle, manually extend the locking pin to be adjusted. Make sure the pin is full extended and locked in the receptacle.
2. Slide the pin locked sensor (PL) in the air cylinder groove (FIGURE 14 and FIGURE 56).
3. Place the PL sensor in the zone where it is activated. Move slowly the sensor toward the back side of the cylinder until it is deactivated. Bring back slowly the sensor (adjustment direction) and when it is activated again, continue to move it on 3/32" to 1/8". Tighten the sensor screw (figure 14).
4. Using a compressed air nozzle, manually retract the locking pin.
5. Slide the pin unlocked sensor (PU) in the air cylinder groove.
6. Place the PU sensor in the zone where it is activated. Move slowly the sensor toward the back side of the cylinder until it is deactivated. Bring back slowly the sensor (adjustment direction) and when it is activated again, continue to move it on 1/8" to 5/32". Tighten the sensor screw (figure 14).

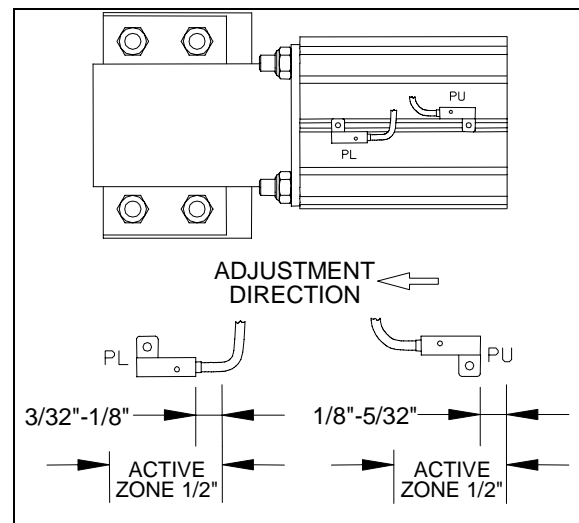

FIGURE 14 : SENSOR SWITCH ADJUSTMENT

Note: It is important to adjust the sensor following the adjustment direction (figure 14).

Section 26: VIP SLIDE-OUT

2.5 PIN RECEPTACLE

The front slide-out has six pin receptacles, and the rear slide-out has only four (figure 2 and figure 3). The pin receptacles installed on exterior panels are different from the pin receptacles installed on windows.

2.5.1 Maintenance

Inspect frequently all the pin receptacles to be sure they are not obstructed. The presence of metal chips in the receptacle may be a sign of a pin not aligned properly. Check for any rust on inner edges. Also, make sure the plastic cap is still there and not damaged.

2.5.2 Replacement

1. Extend the slide-out.
2. From inside the slide-out, unscrew one of the four screws of the pin receptacle. Keep the washer.
3. Screw an M10-1.5 x 75 threaded rod through the pin receptacle to hold the bolting plate in place and prevent it from moving.
4. Remove the other screws and replace them with threaded rods.
5. Remove the pin receptacle.
6. Remove the old sealant. Clean the panel or glass inner contact surfaces with alcohol.

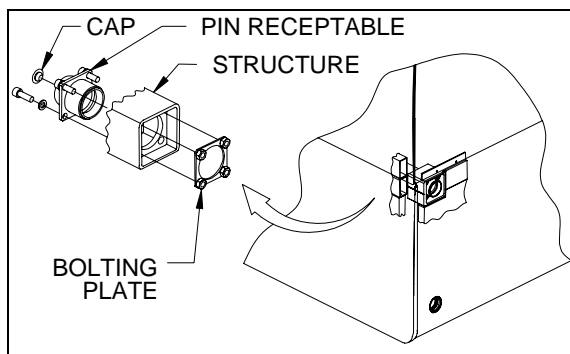

FIGURE 15 : PIN RECEPTACLE INSTALLATION

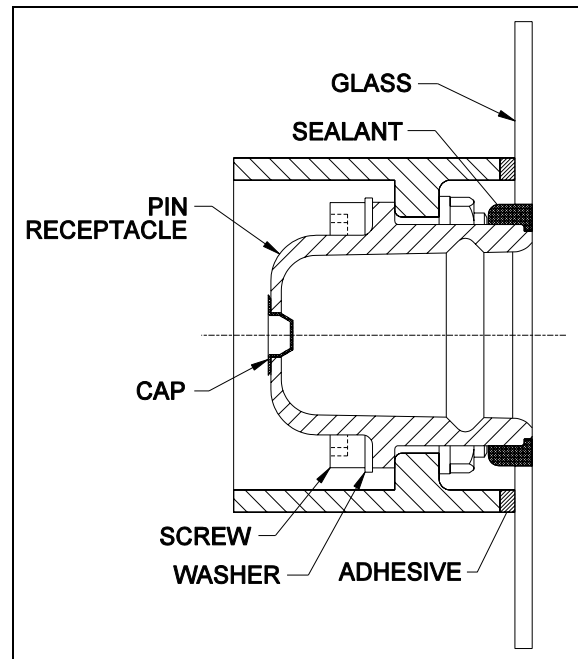

FIGURE 16 : PIN RECEPTACLE ON GLASS

7. Apply black Sika 222 UV or equivalent product on the glass surface contact with the pin receptacle (figure 16), and black Sika 221 or equivalent product on the panel surface contact with the pin receptacle (figure 17).
8. Install a pin receptacle on the threaded rods. Put the plastic cap back on.
9. One by one, replace the threaded rods with the washers and the screws.
10. Clean excess sealant with alcohol.
11. Readjust the locking pins as described in section 2.2 (if needed).

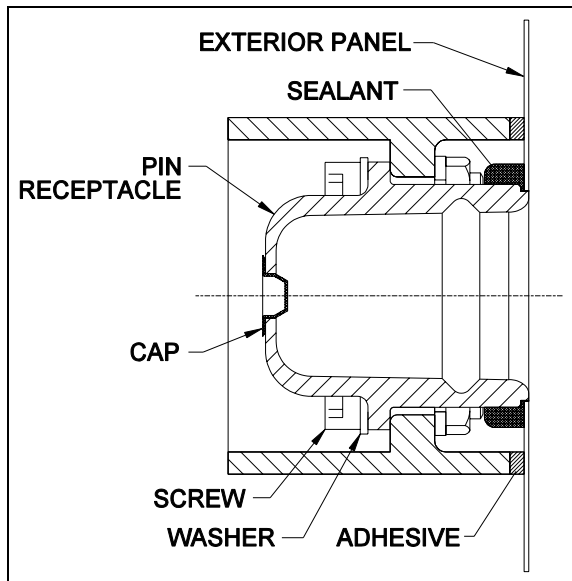

FIGURE 17 : PIN RECEPTACLE ON STAINLESS STEEL PANELS

3. ROOF REINFORCING ROD

Caution: The front slide-out roof reinforcing rod may have to be adjusted after a load variation inside the vehicle or on the top of the vehicle.

Caution: Always lock the turnbuckle using the jam nut to prevent loosening.

The roof reinforcing rod is located on the upper horizontal member of the front slide-out and is welded on the roof arches (figure 18).

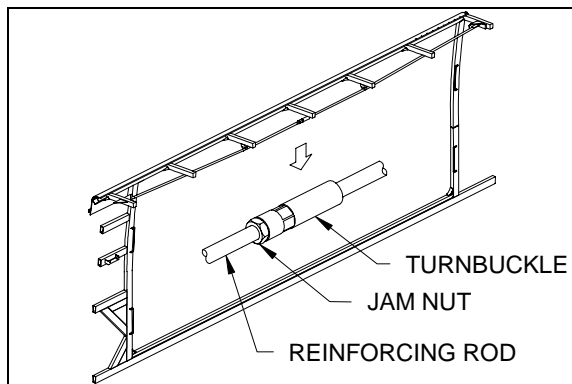

FIGURE 18 : FRONT SLIDE-OUT ROOF REINFORCING ROD

This rod allows an adjustment between the slide-out horizontal member and the roof. When screwing the turnbuckle, the roof is moved upward, and vice versa. Use this rod to adjust the horizontal member parallel to the slide-out. A member not parallel with the slide-out may cause the inflatable seal to leave the wiper seal.

4. RACK

Slide-out movements are made by a system of racks and pinions. There are four racks on each slide-out (figure 2 and figure 3). These racks are made of plastic. Because of that, the pinion should never have to be replaced, but only the racks.

4.1 MAINTENANCE

Once a year, check the racks for broken or worn tooth, especially the front slide-out racks. Also, check the bottom rack fastening hole teeth that are weaker and might break (figure 19). Replace the racks if excessive wear is present. Clean racks from sand or other debris. Check that the bolts are tight and check the backlash between the gear and the rack. Excessive backlash indicates rack wear.

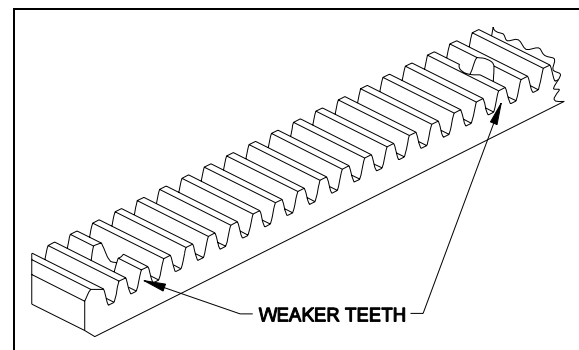

FIGURE 19 : BOTTOM RACK

4.2 UPPER RACK REPLACEMENT ON BOTH SLIDE-OUT

The procedure is the same for both units.

1. The slide-out must be retracted and all the pins locked.
2. Deflate the air seal completely to prevent any damage (see the slide-out operation manual).
3. Loosen the pinion keyless bushing of the rack to be changed and slip the bushing out of the pinion.
4. From inside the slide-out, unscrew all the rack screws (figure 2 and figure 3).
5. Move the pinion away from the rack and remove the rack from its location by pulling it out.

Section 26: VIP SLIDE-OUT

6. Remove the old waterproof material from the slide-out structural rack seat.
7. Apply Sika 221 sealant or equivalent product in the rack seat to prevent water infiltration.
8. Install a new rack in the rack seat. Apply sealant Sika 221 or equivalent product on screw thread before screwing them.
9. Reinstall the keyless bushing into the pinion. Tighten the pinion keyless bushing according to the procedure in section 5.6.

Caution: Make sure all keyless bushings are tightened to 125 lb-ft before unlocking the pins or moving the slide-out. Refer to section 5.6 for torque wrench settings.

10. Re-inflate the air seal at 10 psi.

4.3 FRONT SLIDE-OUT LOWER RACK REPLACEMENT

1. Remove the slide-out from the vehicle as described in section 1.3.
2. From under the slide-out, unscrew all the rack screws and remove the rack.

Note: The rack for the pinion and guide wheel assembly is narrower than the other one.

3. Install a new rack. Tighten the screws using Loctite 242 or equivalent product.
4. Reinstall the front slide-out inside the vehicle as described in section 1.4.

Caution: Make sure all keyless bushings are tightened to 125 lb-ft before unlocking the pins or moving the slide-out. Refer to section 5.6 for torque wrench settings.

4.4 REAR SLIDE-OUT LOWER RACK REPLACEMENT

1. Deflate the air seal completely to prevent any damage (see the slide-out operation manual).
2. Using the slide-out control switch and/or the manual override procedure, extend the slide-out about one foot.

3. From outside, unscrew and remove only the two first rack screws starting from the slide-out panel.
4. Using the manual override procedure only, retract the slide-out to its fully closed position. Lock all the locking pins.
5. Loosen the pinion keyless bushing of the rack to be changed.
6. From under the slide-out, unscrew all the rack screws and remove the rack.

Note: The rack for the pinion and guide wheel assembly is narrower than the other one.

7. Install a new rack between the slide out structural rack seat and the pinion. Tighten the screws accessible using Loctite 242 or equivalent product.
8. Tighten the pinion keyless bushing as described in section 5.6.

Caution: Make sure the keyless bushing is tightened to 125 lb-ft before unlocking the pins or moving the slide-out. Refer to section 5.6 for torque wrench settings.

9. Using the slide-out control switch and/or the manual override procedure, extend the slide-out about one foot.
10. Tighten the two remaining screws using Loctite 242 or equivalent product.
11. Using the slide-out control switch and/or the manual override procedure, retract the slide-out to its fully closed position. Lock all the locking pins.
12. Re-inflate the air seal at 10 psi.

5. PINION

Caution: The front slide-out upper shaft pinions may have to be readjusted and re-synchronized after a load variation in the slide-out (section 5.6).

Caution: Make sure all keyless bushings are tightened to 125 lb-ft before unlocking the pins or moving the slide-out. Refer to section 5.6 for torque wrench settings. A lower torque value

may cause the bushing to slip on the shaft, and a higher torque value may break the bushing.

5.1 MAINTENANCE

Note: One of the two lower shaft pinions is mounted with a plastic guide wheel. When replacing this pinion, it is important to put back the guide wheel (see section 5.7).

To tighten or loosen the keyless bushing, use those specific tools (see section 1.1):

- crowfoot wrench 1 ½";
- torque wrench;
- combination wrench 1 ¾";
- pipe wrench;
- drive extension 5";
- socket 1 ½".

5.2 UPPER SHAFT PINION REPLACEMENT

Note: The procedure is the same for the front and rear slide-out, except when specified.

1. Deflate the air seal completely to prevent any damage (see the slide-out operation manual).
2. Use the slide-out control switch and/or the manual override procedure to extend the slide-out completely.
3. **For the front slide-out only:** retract manually the slide-out on 1" from its fully extended position to release stopper contact.

Caution: Ensure suspension stabilization before using the height adjustable tables to prevent any damage to the vehicle or slide-out structure.

4. Support each end of the slide-out with height adjustable tables. Use plywood panels covered with soft material, such as carpet, to prevent any damage to the slide-out under panels and the exterior panel edge (figure 7). The supporting tables should not obstruct the slide-out bottom racks. Rise up the tables to support the slide-out without lifting it.
5. Loosen the upper shaft keyless bushing of the rack pinion to be changed.

6. For the motor side pinion, remove the upper jaw coupling and the upper right angle drive (see section 8).
7. From inside the vehicle, loosen the upper shaft pillow block nuts and remove the shims behind the pillow blocks. Keep note of the shims position (figure 8 and figure 1).
8. Remove the pinion with its keyless bushing.
9. Install the new pinion on the driving shaft. Check the keyless bushing condition before putting it back in place; use a new one when necessary. Pre-tighten the keyless bushing to 100 lb-ft, to be able to move the slide-out to its retracted position.
10. Reinstall the pillow blocks shims and tighten the nuts. Leave no clearance between the pinion and the rack. If necessary, use new shims to adjust.
11. Reinstall (when applicable) the angle drive and the universal joints taking care that both jaw couplings are aligned. Re-engage the jaw couplings.
12. With the slide-out on his supporting tables, use the manual override procedure to move it inside the vehicle to its retracted position.
13. Using a compressed air nozzle, lock all the locking pins one by one.
14. Synchronize the new pinion as described in section 5.6.
15. Re-inflate the air seal at 10 psi.

Caution: The slide-out receptacles must be perfectly aligned with the locking pins before locking them.

Caution: Make sure all keyless bushings are tightened to 125 lb-ft before unlocking the pins or moving the slide-out. Refer to section 5.6 for torque wrench settings.

5.3 FRONT SLIDE-OUT DRIVER SIDE LOWER SHAFT PINION REPLACEMENT

1. Remove the front slide-out as described in section 1.3.

Section 26: VIP SLIDE-OUT

- Note, in relation with the structure, the exact position of the pinion located near the driver seat if it has to be changed.
- Unscrew both lower shaft pillow blocks but:
 - do not change the base plate adjustment screws for the pillow block located near the electric motor (figure 27);
 - take note of the shim location for the pillow block located near the driver seat (figure 27).
- Loosen the keyless bushing of the pinion to be replaced. Slip the pinion and its bushing out of the shaft. Check the keyless bushing and the guide wheel condition and replace them if needed (see section 5.7).
- Reinstall the new pinion and the keyless bushing on the shaft without tightening the bushing.
- Reinstall the driving shaft on the vehicle, making sure the pillow blocks are located at their same previous location and are both at the same distance from the structure. Replace the shims and tighten the bolts.
- Reposition the pinion located near the driver seat and tighten its keyless bushing as described in section 5.6.
- Reinstall the slide-out in the coach as described in section 1.4.

Caution: Make sure the keyless bushing is tightened to 125 lb-ft before unlocking the pins or moving the slide-out. Refer to section 5.6 for torque wrench settings.

5.4 FRONT SLIDE-OUT MOTOR SIDE LOWER SHAFT PINION REPLACEMENT

- The slide-out must be retracted and all the pins locked.
- Loosen the pinion keyless bushing.
- Disengage the lower shaft jaw coupling.
- From the baggage compartment, unscrew the pillow block supporting plate screw (figure 20). Do not change the plate

adjustment screws for the pillow block (figure 27).

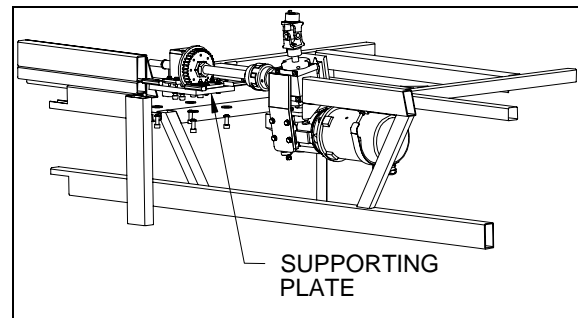

FIGURE 20 : PILLOW BLOCK SUPPORTING PLATE

- Bend slightly the shaft and slip the jaw coupling and the keyless bushing out of the shaft. Slip the pinion and guide wheel assembly out of the shaft and replace them.
- Replace the keyless bushing. Change it if damaged. Replace the jaw coupling on the shaft.
- Screw back the pillow block supporting plate on the vehicle structure.
- Re-engage the jaw coupling.
- Synchronize the new pinion as described in section 5.6.

Caution: Make sure the keyless bushing is tightened to 125 lb-ft before unlocking the pins or moving the slide-out. Refer to section 5.6 for torque wrench settings.

5.5 REAR SLIDE-OUT LOWER SHAFT PINION REPLACEMENT

- The slide-out must be retracted and all the pins locked.
- Loosen the keyless bushing of the lower shaft pinion to be changed.
- Disengage the lower shaft jaw coupling.
- For the motor side pinion only:** Remove the gearbox support (see section 7.2).
- Remove the pinion and the keyless bushing from the shaft.

6. Check the keyless bushing and the guide wheel condition and replace them if needed (see section 5.7).
7. Reinstall the new pinion and the keyless bushing on the shaft without tightening the bushing.
8. Re-engage the jaw coupling and adjust the gearbox support if necessary.
9. Tighten the pinion keyless bushing as described in section 5.6.

Caution: Make sure all keyless bushings are tightened to 125 lb-ft before unlocking the pins or moving the slide-out. Refer to section 5.6 for torque wrench settings.

5.6 PINION SYNCHRONIZATION

Caution: The front slide-out upper shaft pinions may have to be readjusted and re-synchronized after a load variation in the slide-out.

The four pinions need to be synchronized for the slide-out to move straight when extending and retracting. This synchronization is possible with the use of Trantorque keyless bushings. These keyless bushings need a specific tightening torque value to ensure proper pinion transmitting torque. They also need specific tools to be tightened, as described in section 18.2.

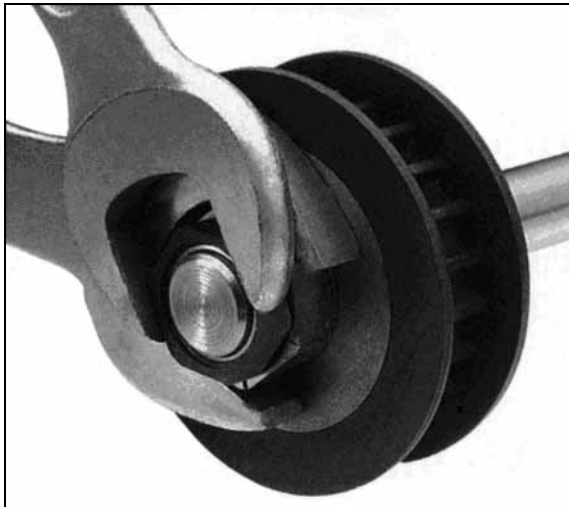

FIGURE 21 : KEYLESS BUSHING TIGHTENING

To tighten the keyless bushing, use a special open-end wrench to retain the yellow part and another wrench to tighten the black part. Figure 20 shows how to tighten the keyless bushing.

When tightening, make sure the pinion does not move or rotate.

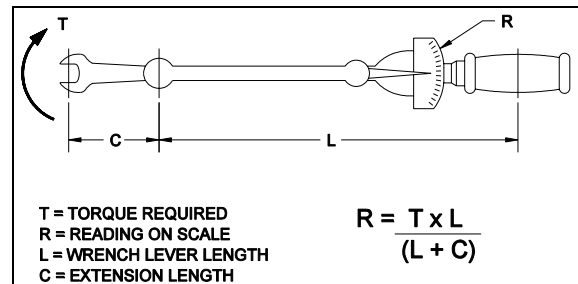

FIGURE 22 : TORQUE WRENCH FORMULA

Caution: Make sure all keyless bushings are tightened to 125 lb-ft before unlocking the pins or moving the slide-out. A lower torque value may cause the bushing to slip on the shaft, and a higher torque value may break the bushing. The torque may need to be recalculated depending of the wrench size. Refer to figure 22 for wrench size compensation.

$$R = \frac{T \times L}{(L + C)}$$

T = TORQUE REQUIRED
R = READING ON SCALE
L = WRENCH LEVER LENGTH
C = EXTENSION LENGTH

REAR SLIDE-OUT PINIONS

To adjust and synchronize the rear slide-out pinions, tighten the keyless bushing to 125 lb-ft (refer to figure 22 for wrench size compensation) after having centered the pinion in its rack. Take note that when the keyless bushing nut is tightened, the pinion moves about 1/16" to 3/32" toward the slide-out center.

FRONT SLIDE-OUT PINIONS

A torque must be applied on the upper shaft to compensate the effect of the center of gravity of the slide-out when inside the vehicle. This gravity effect causes the slide-out to fall down inside the vehicle. The torque applied on the shaft forces the pinions to push the upper part of the slide-out outside the vehicle to counterbalance the gravity effect.

Note: The driver side keyless bushing located on the lower shaft is not accessible when the slide-out is installed. Therefore, it must be tightened before installing the slide-out.

Follow these steps to adjust and synchronize the front slide-out pinions.

1. The slide-out must be retracted and all the pins locked.
2. Make sure the adjustable shaft assembly is tightened (refer to figure 23).

Section 26: VIP SLIDE-OUT

3. On the driver side, tighten the upper shaft keyless bushing to 125 lb-ft (refer to figure 22 for wrench size compensation). Make sure the pinion is centered and fits well in its rack to eliminate any possible backlash. Take note that when the keyless bushing nut is tightened, the pinion moves about 1/16" to 3/32" toward the slide-out center.
4. Tighten the other side keyless bushing to 125 lb-ft by using the same procedure described in the previous step.
5. On the lower shaft, tighten the left-hand side keyless bushing to 125 lb-ft (refer to figure 22 for wrench size compensation).
6. Once all the keyless bushings are tightened, unplug the air tubing from the locking pins air valve to prevent movement of the slide-out during the verification of the pinion synchronization.

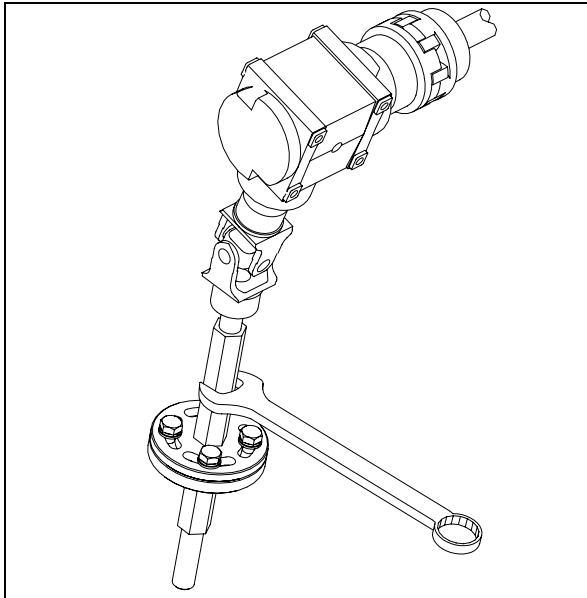

FIGURE 23 : SLIDE-OUT ADJUSTABLE SHAFT ASSEMBLY

7. Operate the slide-out and check if the exterior panels of the slide-out are parallel with the vehicle panels. If not, rotate the upper part of the adjustable shaft assembly as required to obtain proper alignment (refer to figure 23).

Caution: Make sure the adjustable shaft bolts are tightened to 25 lb-ft to ensure that the adjustable shaft assembly is properly locked.

5.7 GUIDE WHEEL

A plastic wheel is mounted on one of the lower shaft pinion on each slide-out. This wheel is used to guide the slide-out when extending or retracting. The wheel follows a track between the rack and the slide-out structure (figure 10). To replace this wheel, remove the pinion from the shaft and unscrew the guide wheel screws from the pinion (refer to section 5.4 and 5.5).

5.8 PLASTIC STOPPER

There is a UHMW plastic stopper used to block any axial movement of the front slide-out lower shaft (figure 27). This stopper must be adjusted 1/32" away from the pinion.

6. ELECTRIC MOTOR

The power is supplied by a 1/3 HP electric motor coupled with a speed reduction gearbox.

6.1 MAINTENANCE

Inspect the electrical connections and their watertightness. Check that the bolts and the holding metal strap are tight (figure 24).

6.2 REPLACEMENT

1. The slide-out must be retracted and all the pins locked.
2. Disconnect the electric wire cable from the motor. Release the motor holding metal strap (figure 24).

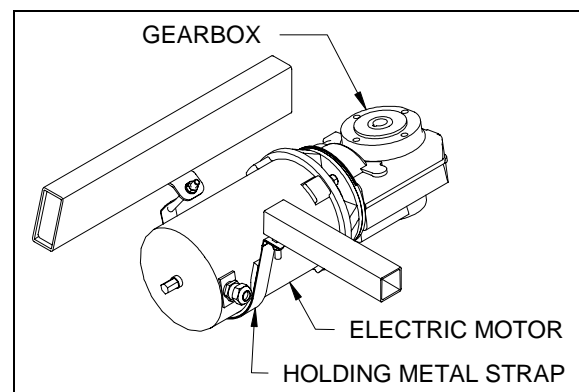

FIGURE 24 : ELECTRIC MOTOR

3. Remove the motor from the gearbox.
4. Fasten the new motor to the gearbox using screws.
5. Replace and tighten the motor holding metal strap (figure 24).

6. Re-connect the motor electric cable.

7. SPEED REDUCTION GEARBOX

The speed reduction gearbox used is a helical worm gear type. This gearbox has a 140:1 ratio and the output shaft is self-locking. See section 18.3 for gearbox specifications.

7.1 MAINTENANCE

Inspect the gearbox to check if there is any leakage or backlash in the box or between the keys and their keyseat. Replace the gearbox if excessive wear is present. Check that all bolts are tight.

Check the oil level. The gearbox is lubricated for life and the oil should not have to be changed.

Check the gearbox axle alignment with the right angle drive and adjust it if necessary (section 8).

7.2 GEARBOX REPLACEMENT

1. The slide-out must be retracted and all the pins locked.
2. Disengage the lower jaw coupling, and for the front slide-out, remove the universal joint from the right angle drive shaft (figure 1).
3. **For the front slide-out:** Remove the reinforcement plate from the gearbox (figure 25).

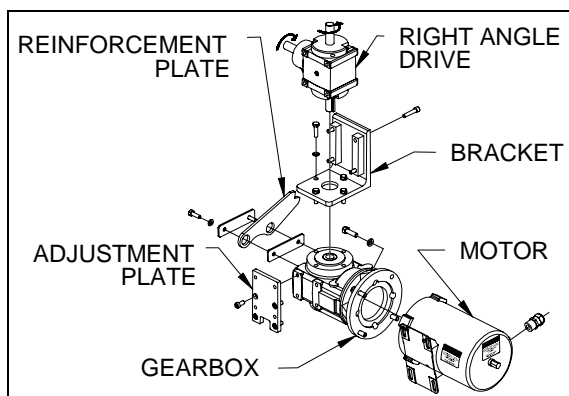

FIGURE 25 : FRONT SLIDE-OUT MOTOR ASSEMBLY

4. Remove the motor from the gearbox (see section 6.2).
5. Remove the gearbox assembly (figure 25 and figure 26). Note the shim position.

6. Unscrew the right angle drive from its bracket (figure 25 and figure 26).

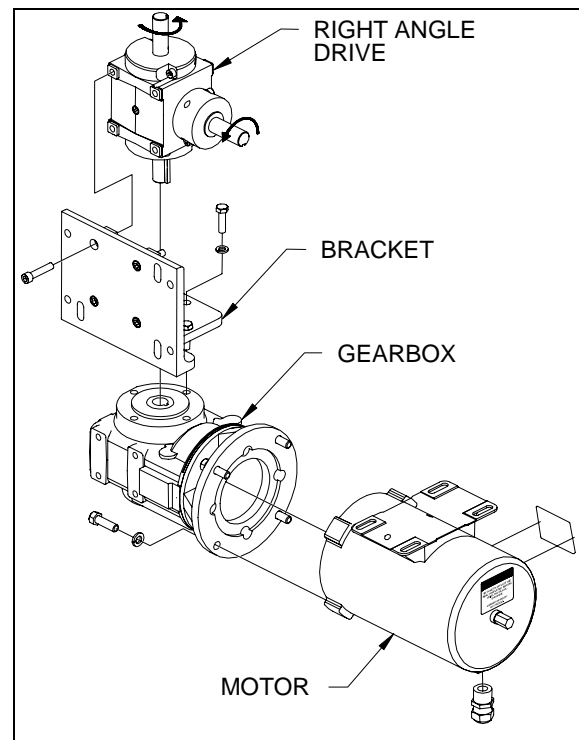

FIGURE 26 : REAR SLIDE-OUT MOTOR ASSEMBLY

7. Remove the right angle drive bracket and for the front slide-out, remove the adjustment plate from the speed reduction gearbox.
8. Install the right angle drive bracket on the new gearbox without tightening the screws. For the front slide-out, install the adjustment plate on the speed reduction gearbox using Loctite 242 or equivalent product.

Caution: The right angle lower vertical key must be welded on its keyseat to prevent it from moving or falling.

9. Check the right angle drive rotation (figure 25 and figure 26) before installing it on the bracket. Align the right angle drive shaft with the gearbox hollow shaft and tighten all screws.
10. Reinstall the speed reduction gearbox assembly on the vehicle mounting bracket without tightening the screws.
11. Using shims and, for the front slide-out, the vehicle mounting bracket adjustment screw, align the right angle drive shaft jaw coupling with the slide-out lower shaft jaw coupling.

Section 26: VIP SLIDE-OUT

12. Reinstall the motor on the speed reduction gearbox (see section 6.2).
13. Reinstall the universal joint and the jaw coupling on the right angle drive. Use the motor output shaft to align the keyseats.
14. **For the front slide-out:** Reinstall the reinforcement plate

8. RIGHT ANGLE DRIVE

Caution: The right angle lower vertical key must be welded or punched on its keyseat to prevent it from moving or falling.

The right angle drive simultaneously transmits the movement to the lower and upper driving shafts via a vertical shaft. To preserve the same rotating speed, before being transmitted to the upper shaft, the movement coming from the speed reduction gearbox passes through a second right angle drive, which has a 1:1.5 ratio. That is due to the fact that the lower shaft pinions have more teeth than those on the upper shaft.

8.1 MAINTENANCE

Inspect the right angle drive to check if there is any leakage or excessive backlash in the box or between the keys and their keyseat. Replace the keys or the right angle drive if excessive wear is present. When replacing, weld the lower vertical shaft key on its keyseat. Check that all bolts are tight.

Check the oil level and lubricate the right angle drive once every three years.

Check the right angle drive axle alignment with the driving shafts and adjust it if necessary, using the shims and/or the adjustment screw.

8.2 LOWER SHAFT RIGHT ANGLE DRIVE REPLACEMENT

Use the same procedure as for the speed reduction gearbox (section 7).

8.3 UPPER SHAFT RIGHT ANGLE DRIVE REPLACEMENT

Note: This procedure is the same for both slide-out.

1. The slide-out must be retracted and all the pins locked.
2. Disengage the jaw coupling and the universal joint from the right angle drive.
3. Remove the right angle drive and keep note of the shims position.

Caution: Make sure the new right angle drive revolves in the same direction before installing it.

4. Replace the right angle. Reinstall the half jaw coupling on the right angle drive shaft.
5. Screw without tightening the new right angle drive.
6. Using shims, align the right angle drive jaw coupling with the upper shaft jaw coupling.
7. Reinstall the universal joint and re-engage the jaw coupling.

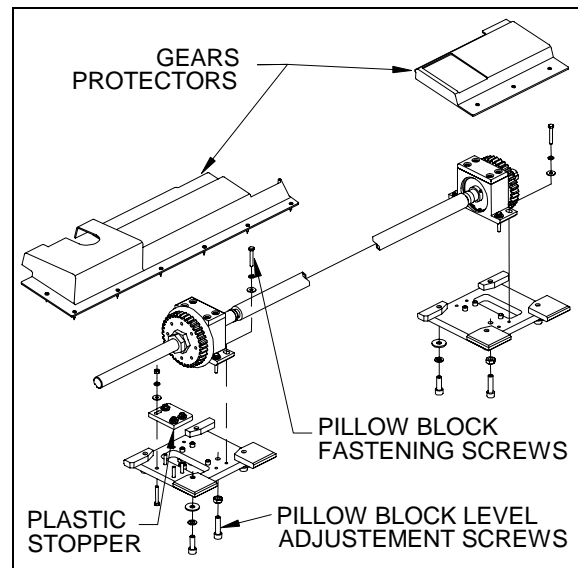

FIGURE 27 : FRONT SLIDE-OUT SLIDING PAD LEVELLING

9. JAW COUPLING

9.1 MAINTENANCE

Inspect the jaw couplings to check if there is backlash between the key and the keyseat, or between the coupling and the plastic spider. Also, check the spider condition. Check that the setscrews are tight.

9.2 REPLACEMENT

The jaw coupling replacement procedure is the same as for the right angle drive, section 8.2 and 8.3.

10. UHMW SLIDING PAD

The UHMW sliding pads support the slide-out, and offer a frictionless surface for the slide-out movement.

10.1 MAINTENANCE

Check the sliding pad for a non even or abnormal wear, or plastic deterioration. Adjust the sliding pad when its surface is not parallel with the slide-out under panels. Replace it when its thickness is below 11/32" or if the lower racks interfere with the lower shaft pinions.

10.2 REPLACEMENT & ADJUSTMENT

1. Remove the slide-out as described in section 1.3 and 1.5.
2. Unscrew and remove the used UHMW sliding pad from the pillow block.

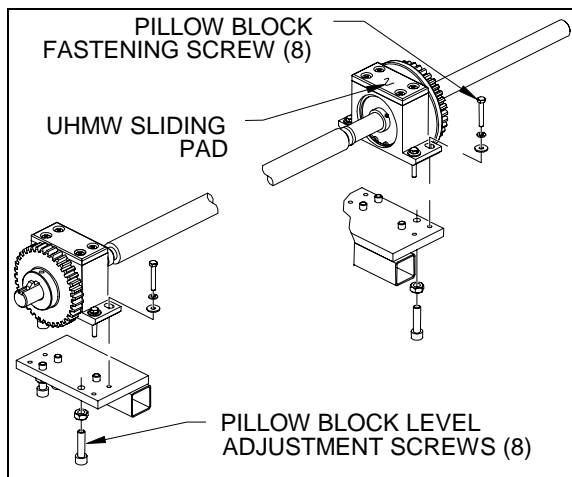

FIGURE 28 : REAR SLIDE-OUT SLIDING PAD LEVELLING

3. Check and make sure that the UHMW sliding pad and the vehicle frame structure are parallel and within a distance of 22.2mm (7/8") (figure 48). If not, an adjustment is needed. To adjust the rear slide-out UHMW sliding pads and the front slide-out motor side UHMW sliding pad, use the pillow block adjustment screws located under the fixation plates (figure 27 and figure 28). To adjust the front slide-out UHMW sliding pad located on the driver side, add or remove shims under the pillow block (figure 27).

4. Make sure both pillow blocks are at the same distance from the structure and tighten the pillow block fastening screws and the adjustment screw jam nut (figure 27 and figure 28).
5. Reinstall the slide-out in the vehicle (see sections 1.4 and 1.6).

11. VERTICAL SHAFT AND UNIVERSAL JOINT ASSEMBLY

11.1 MAINTENANCE

Note: The taper keys used on the vertical shaft assembly are specially made keys with a wider width. Do not replace them with standard taper keys.

Inspect the universal joints and the shafts to check if there is leakage or backlash between the keys and their keyseat. Replace the keys, the joint or the shaft if excessive wear is present. When replacing key, ensure to block the taper key against the shaft and the universal joint keyseats. Check that all setscrews are tightened.

11.2 UNIVERSAL JOINT REPLACEMENT

1. The slide-out must be retracted and all the pins locked.
2. Unscrew the setscrews and remove the universal joint.

For the bottom vertical shaft: unscrew the vertical pillow block keeping note of the shims position.

For the rear slide-out vertical shaft: disengage the coupling between the vertical shaft and the lower angle drive.

Note: If possible, use shafts and universal joints that provide same keyseat alignment to avoid pinion re-synchronization.

3. Install new universal joints.
4. Lock the taper keys against the shaft and the universal joint keyseats to prevent them from moving. Use Loctite 242 or equivalent product on all set screws.

Section 26: VIP SLIDE-OUT

5. Paint the universal joints to prevent rust.

11.3 VERTICAL SHAFT REPLACEMENT

Use the same procedure as for the universal joint (section 11.2).

12. SLIDE-OUT PNEUMATIC SYSTEM

The slide-out is controlled by a pneumatic and electric system. Mainly, the pneumatic system consists of electrical operating valves that control slide-out components and safety operations. Pneumatic schematic diagrams are annexed for better understanding of the system.

12.1 DESCRIPTION

AIR PRESSURE INLET VALVE

The slide-out air pressure comes from the air pressure inlet valve on the pneumatic panel in the front service compartment (figure 30).

LOCKING PIN VALVE

The locking pin movement is done using a 5-port 3-position manifold valve with open center. A manual locking override screw may be used to activate the pin manually in case of trouble. A protection plate covers the locking pin manual override screw to prevent accidental activation (figure 54).

INFLATABLE SEAL VALVE

The inflation and the deflation of the seal are done using a 5-port 2-position manifold valve with two coils. One coil is used to inflate the seal and the other one to deflate the seal. When one of the coils is activated (seal deflating valve), the valve will keep its state even if the coil is deactivated. The inflating valve coil is activated to re-inflate the seal when the slide-out reaches its inner or outer limit. The inflatable seal pressure is set at 10 psi and this pressure is always on the seal as long as the accessory air tank (which is the slide-out air supply) is not empty (figure 54).

VACUUM GENERATOR

A vacuum generator using Venturi principle is controlled by a 5-port 2-position manifold valve and is used to evacuate the air faster from the seal and to ensure that the seal surface does not stay in contact with the slide-out (figure 54).

VACUUM SWITCH

A vacuum switch is mounted on the vacuum generator output port and is used as an input signal when the vacuum reaches the 2" Hg set point. This input signal will detect an inflatable seal failure if the 2" Hg set point is not reached after an 8 seconds delay (figure 54).

TAG AXLE VALVE

The automatic control unloading tag axle valve is used to freely lock and unlock the front slide-out pins. The tag axle is not raised during this process. A 3-port 2-position normally closed valve is connected to the air spring valve operator. An air system schematic diagram is annexed to show the modifications. This valve is located in the compartment near the main power compartment (figure 29).

RACK CLEANING AIR NOZZLE

Both slide-out upper racks are not protected against foreign material and water when the slide-out is extended. To prevent damage to the rack and pinion mechanism, an air nozzle is placed above each upper rack to clean it when the slide-out is retracted. A 5-port 3-position manifold valve with open center is used to blow air to nozzles for both slide-out (figure 54).

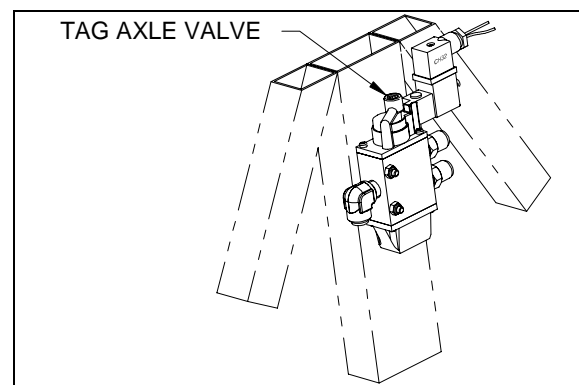

FIGURE 29 : TAG AXLE VALVE

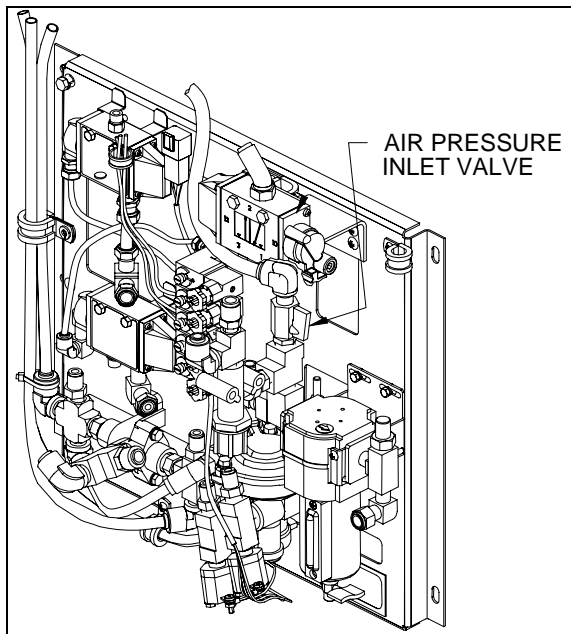

FIGURE 30 : FRONT SERVICE COMPARTMENT

12.2 PNEUMATIC INTERCONNECTION WITH PREVOST VEHICLE

The slide-out pneumatic system air supply comes from the converter air supply valve located on the pneumatic panel in the front service compartment (figure 30). A valve is also added on this panel for an interlock with the parking brake. Another valve is added on the middle structure over the rear axle accessible by the driver side rear suspension access panel (figure 29). This valve activates the tag axle unloading when locking or unlocking the front slide-out.

Pneumatic circuit modifications made on the vehicle are shown on pneumatic diagrams annexed.

12.3 MAINTENANCE

COMPRESSED AIR LINE

Inspect all compressed air line tubing for cut, swelling, kink or other damage or deterioration. Inspect the pneumatic fittings and components for any leak. The slide-out air supply is connected to the accessory air tank and the maintenance is specified in the "brake and air system" section from the Prevost maintenance manual.

INFLATABLE SEAL CIRCUIT

The efficiency of the seal could be affected by impurities, such as white powder in the pneumatic control valve. It is recommended to inspect the inflatable seal control components once a year to prevent malfunction. In this case, remove the seal valves and clean the interior valve components using a compressed air nozzle. Do the same thing with the vacuum generators.

The inflatable seal pressure must be set from 7 to 10 psi maximum. It is recommended to check the inflatable seal pressure once a month to ensure sealing efficiency and prevent any infiltration from outside.

VACUUM SWITCH

The vacuum switch used to control the vacuum generator valve may have to be adjusted if malfunction is suspected. The vacuum is factory pre-set to 2" Hg. To check the vacuum set point, use a vacuum gage adapter at the seal valve output. Operate the slide-out and check the maximum vacuum value. If needed, adjust the vacuum set point with the adjustment screw located between the electrical tab connectors. Turn the screw clockwise to lower the vacuum set point and counterclockwise to raise it.

12.4 SEAL

Note: Refer to the Prevost parts manual for descriptions of the sealant and adhesives used.

The slide-out sealing device is used to prevent any type of infiltration that may occur between the structure body and the slide-out itself. It is composed of an inflatable seal which is used as a primary sealing device for both retracted and extended slide-out position and a wiper seal as a secondary sealing device which is used to wipe water out and to ensure sealing during slide-out movement.

The front slide-out inflatable seal air inlet is located in the third baggage compartment on the driver side close to the front slide-out electric motor (figure 32). The rear slide-out inflatable seal air inlet is located on the structure post facing the rear of the vehicle (figure 33).

Section 26: VIP SLIDE-OUT

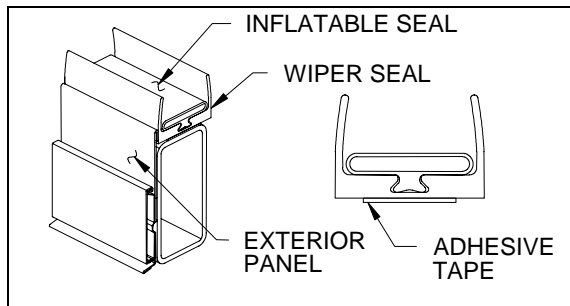

FIGURE 31 : SEAL ASSEMBLY

The seal deflation is done each time the slide-out moves. The deflating valve coil is activated before and during the slide-out movement. When the slide-out reaches its retracted or extended position, the deflating valve coil is deactivated before activate the inflating valve for 1 second to re-inflate the seal.

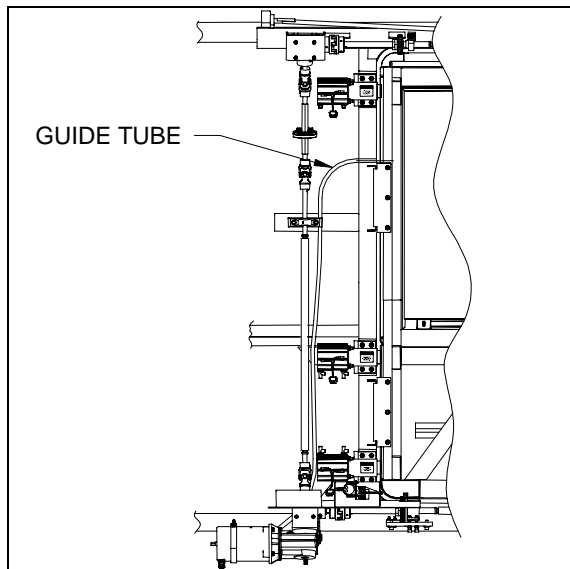

FIGURE 32 : FRONT SLIDE-OUT INFLATABLE SEAL AIR INLET

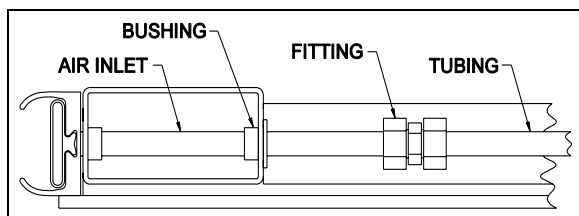

FIGURE 33 : REAR SLIDE-OUT INFLATABLE SEAL AIR INLET

Caution: Make sure the inflatable seal is deflated when manually moving the slide-out during service maintenance. Deflate both inflatable seals completely by turning clockwise the relieving shut-off valve (figure 54).

The vacuum generator valve is activated simultaneously with seal valve for 8 seconds. The vacuum switch will detect a vacuum valve or generator failure if the 2" Hg set point is not reached after an 8 seconds delay. The green LED on the slide-out control switch or the slide-out telltale will flash error code #13. Refer to the troubleshooting tables at the end of this section.

Caution: Check before using any cleaning or adhesive product on seal, panel or glass to prevent alteration or damage.

12.4.1 Maintenance

The inflatable seal pressure must be set from 7 to 10 psi maximum with the pressure regulator. It is recommended to check the inflatable seal pressure once a month to ensure sealing efficiency and prevent any infiltration from outside. Check both seals for air leaks or cracks. Check the sealant between the inflatable seal and the exterior panels and glasses. Add sealant if necessary.

12.4.2 Seal assembly removal

Warning: Always wear the appropriate safety equipment. Maintain adequate ventilation at all time.

1. Retract the slide-out 2" inside the vehicle (section 12.4.1).
2. Unplug the tubing from the inflatable seal air inlet (figure 32 and figure 33). Keep the bushing.
3. Unstick and remove the wiper seal from the structure.
4. Scrape remaining tape from the structure. Remove old sealant that was between the wiper seal and the exterior panels and glasses.

12.4.3 Seal assembly installation

Note: This procedure is to install the inflatable seal assembly on the structure.

Warning: Always wear the appropriate safety equipment. Maintain adequate ventilation at all time.

Caution: Always apply product in the same direction to prevent dirt from being brought back.

Caution: Check before using any cleaning or adhesive product on seal, panel or glass to prevent alteration or damage.

Note: Refer to the slide-out parts manual for descriptions of primer, cleaner, sealant and adhesives used.

Note: Refer to the product specification for drying time.

1. Retract the slide-out 2" inside the vehicle (section 12.4.1).
2. Clean the part of the structure that will receive the inflatable seal and also the back of the exterior panel and glasses with a chix cloth and thinner. Use another cloth to dry the surfaces. Wait at least 2 minutes for drying.
3. Rub the structure and also the back of the exterior panel and glasses with a Scotch Brite (or equivalent product).
4. Clean another times the structure and the back of the exterior panel and glasses with a chix cloth and thinner. Use another cloth to dry the surfaces. Wait at least 2 minutes for drying.
5. Clean the structure and the back of the exterior panel and glasses with appropriate cleaner. Wait until the product is dry before proceeding.
6. Seal the gap between the structure and the exterior panels and the gap between the glasses and the fiberglass panels with appropriate sealant. Make sure not to put sealant on the structure surface where the inflatable seal will be placed. Wait until the product is dry before proceeding.
7. Install the inflatable seal on the structure, placing it as close as possible from the exterior side of the structure. Position the air inlet first. Then remove locally the inflatable seal adhesive tape protection, and press the upper corners on the structure and hold them in place for 90 to 120 seconds. Install the lower corners next, then the straight section. Press the straight inflatable seal sections on the structure for at least 15 seconds. Use a small roller to ensure a good adhesive contact on the structure.

8. Seal the gap between the inflatable seal and the exterior panels and the gap between the glasses and the fiberglass panels with appropriate sealant. Wait until the product is dry before proceeding. Remove excess sealant with appropriate cleaner.
9. Replace the bushing and plug the pneumatic tubing on the inflatable seal air inlet (figure 32 and figure 33).

12.4.4 Slide-out 2" inside retraction

1. Manually deflate the seal completely by turning clockwise the relieving shut-off valve (figure 54).
2. Using the manual override procedure, extend the slide-out a few inches so the exterior extrusion screws located on the top of the slide-out are accessible from outside (figure 6).
3. Using a knife cut the sealant between the extrusion and the roof (figure 6). Unscrew and remove the central exterior extrusion and the two end extrusion screws.

Caution: Do not use the automatic retraction system to move the slide-out 2" inside the vehicle, because the limits are not recognized over the closed position. The slide-out will not stop and damage may occur.

4. Turn the ignition to the off position. Using the manual override procedure, move the slide-out 2" inside the vehicle, so the seal is accessible from outside (figure 34).

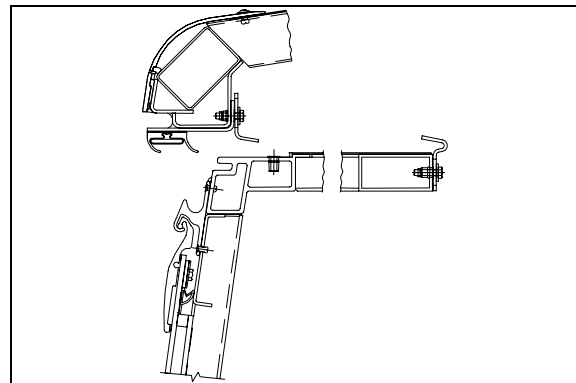

FIGURE 34 : SLIDE-OUT 2" INSIDE – UPPER PART

5. To reinstall the exterior extrusion, inverse the procedure sequence. Apply appropriate sealant on the exterior extrusion screws and between the extrusion, the roof and the edges to prevent water infiltration (figure 6).

13. SLIDE-OUT ELECTRICAL SYSTEM

Warning: Never modify the slide-out electrical wiring without the Prevest Car approval. Any modifications may cause an unexpected slide-out action and could result in personal injuries.

The slide-out electrical system is mainly composed of three electronic controllers for each slide-out. The main controller named “logic controller” is used to manage a predefined logic sequences. The second controller is the “motor controller”, and is used to supply power to the electric motor. Both pairs of controllers are linked by a multiplexed communication network to share input signal conditions. The third controller is the “safety controller”, and is used to prevent unexpected actions from the logic controllers.

The slide-out electrical system is interconnected with the Prevest vehicle electrical system to supply electric power and safety signals to the slide-out control system.

Warning: Before working on the slide-out electrical system, turn the ignition key to the “OFF” position.

13.1 ELECTRICAL INTERCONNECTION WITH PREVOST VEHICLE

The slide-out power supply comes from the master switch control post (24 volts) in the main power compartment. The other interconnections are located on the pneumatic panel and the electrical panel in the front service compartment. All the interconnections are shown on the electrical diagrams of your vehicle.

The input signal coming from Prevest electrical system is:

- parking brake;

These input signals are required for a safe operation of the slide-out.

A signal is added on the driver console (figure 35) to indicate fault on the logic controller or to advise the driver that a structural pin is not locked.

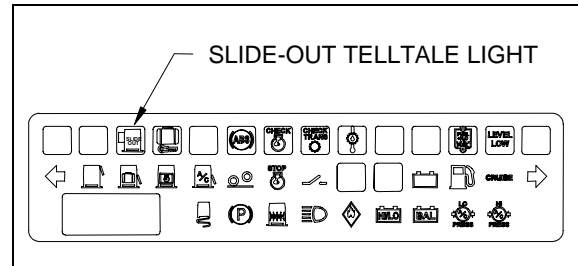

FIGURE 35 : DASHBOARD SLIDE-OUT TELLTALE LIGHT

Warning: If the dash slide-out telltale light starts blinking while on the road for 30 minutes, it means that one of the structural pins (4 bottom pins for the front slide or 2 bottom pins for the rear slide) is not properly inserted. Driving for a long period in this condition can damage the vehicle structure.

Caution: If the dash slide-out telltale light comes ON and stays ON (no blink) after 30 minutes on the road, it means that one of the 2 upper pins (not structural) are not properly inserted. Driving with the upper pins not inserted will not cause damage to the vehicle structure.

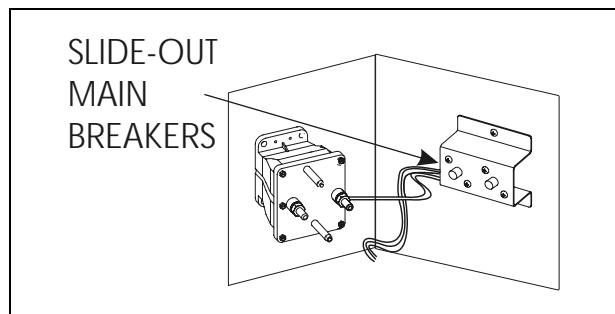

FIGURE 36 : BREAKERS IN MAIN POWER COMPARTMENT

13.2 SLIDE-OUT BREAKERS/FUSE

The main breakers (for both slide-out) are located in the main power compartment (figure 36). All other slide-out breakers are located on the slide-out electrical component panel located in the third baggage compartment on the driver side (figure 38 and figure 41). A relay is added to power the transmission inhibit system in the main power compartment.

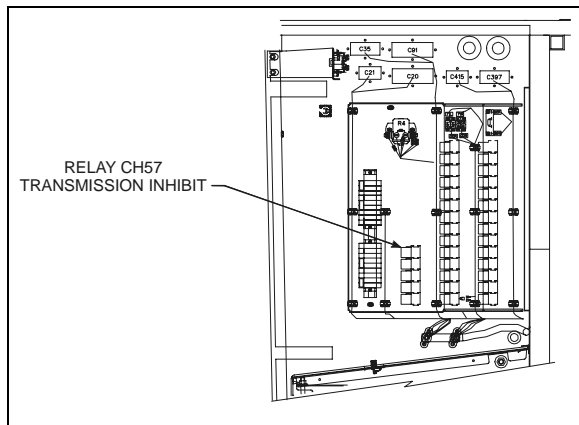

FIGURE 37 : INSIDE MAIN POWER COMPARTMENT

13.3 ELECTRONIC CONTROLLERS

Warning: Never modify the slide-out electrical wiring without the Prevost Car approval. Any modifications may cause an unexpected slide-out action and could result in personal injury.

The slide-out electronic control system consists of two electronic control modules for each slide-out. Each slide-out has a logic controller, a motor controller and a safety controller. They are located in the third baggage compartment on the driver side (see figure 38 and figure 39).

LOGIC CONTROLLER

The slide-out logic controller is used to analyze the input signal conditions and activate outputs like the pneumatic valves and a predefined sequence programmed in a flash memory microprocessor. An input signal comes from the inductive proximity sensor (pinion tooth sensor) to transmit the slide-out position and a second signal comes from a magnetic switch sensor to indicate the "in limit" end. The slide-out logic controller is also used to command the motor controller (drive) to transmit power to the slide-out electric motor.

A multiplexed communication network links both logic controllers and both motor controllers. The multiplexed communication allows moving away controllers and input signals sharing to reduce the overall hard wiring. Each controllers of the network must be identified by a specific number to communicate properly. The front slide-out logic controller is identified by ECU1 and the rear slide-out logic controller by ECU3. This identification set-up is done automatically each time a new logic controller is installed.

Both logic controllers are sharing common output (vacuum valve) and common input

(parking brake. The inputs are connected to the front and rear slide-out logic controller module. The inputs LED and outputs LED are visible on both front and rear slide-out logic controller modules.

The logic controller LED panel is clearly defined to make the troubleshooting easier (figure 55). The upper section indicates the state (locked or unlocked padlock) of each slide-out locking pin. Four buttons (A B C D) are used to set-up the logic controller module and to do diagnostic tests (button D). The inputs and outputs LED sections indicate the state condition of the inputs and outputs. Each LED of the controller panel refers to a connector number (J1 to J4) and is following by pin number of this connector (1 to 12).

The I/O LED section in the lower left corner is used to indicate :

- SLIDE IN: comes "ON" if slide-out is retracting.
- SLIDE OUT: comes "ON" if the slide-out is extending.
- FRONT S-O: "ON" if the logic controller is configured as the front slide-out.
- REAR S-O: "ON" if the logic controller is configured as the rear slide-out.

Each logic controller has a sticker to identify the following information for further tracking:

- Serial code number beginning by "CH" and followed by 4 numbers (XXXX);
- Hardware revision "RV:" and followed by a letter and a digit (L.X);
- Manufacturer software version beginning by "Vpr:" and followed by 3 digits (X.XX);
- Client software version beginning by "Vcl:" and followed by 3 digits (X.XX).

MOTOR CONTROLLER

The motor controller is a pulse width modulation (PWM) type controller. This electronic module controls the motor speed variation and the overload current protection.

The motor controllers for both slide-out are linked with the logic controllers by a multiplexed communication network. The front slide-out motor controller is identified by PR3474-1 and the rear slide-out by PR3474-2. Two part

Section 26: VIP SLIDE-OUT

numbers are used to identify the front and the rear slide-out motor controllers.

Each motor controller has a sticker to identify the following information for further tracking:

- Serial code number beginning by "BT" and followed by 4 (XXXX);
- Hardware revision "RV:" and followed by a letter and a digit (L.X);
- Software revision beginning by "V:" and followed by 3 digits (X.XX);
- Rear or front slide-out.

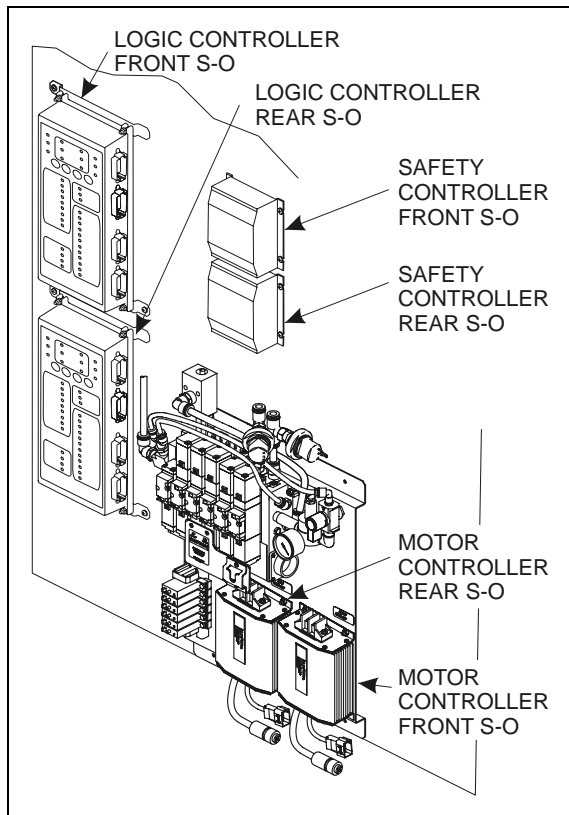

FIGURE 38 : SLIDE-OUT ELECTRICAL PANEL (SMALL A/C)

SAFETY CONTROLLER

The safety controller is used to prevent unexpected actions from the logic controllers. This controller uses relays to interlock the valves and the slide-out motor. Those relays are activated by either "Retracting" or "Extending" buttons. One contact relay cuts off the power to the motor. Two others relays cut off the power to the pin unlocking valve and to the tag axle valve.

With this protection, the slide-out cannot operate accidentally if either retracting or extending button is not pressed.

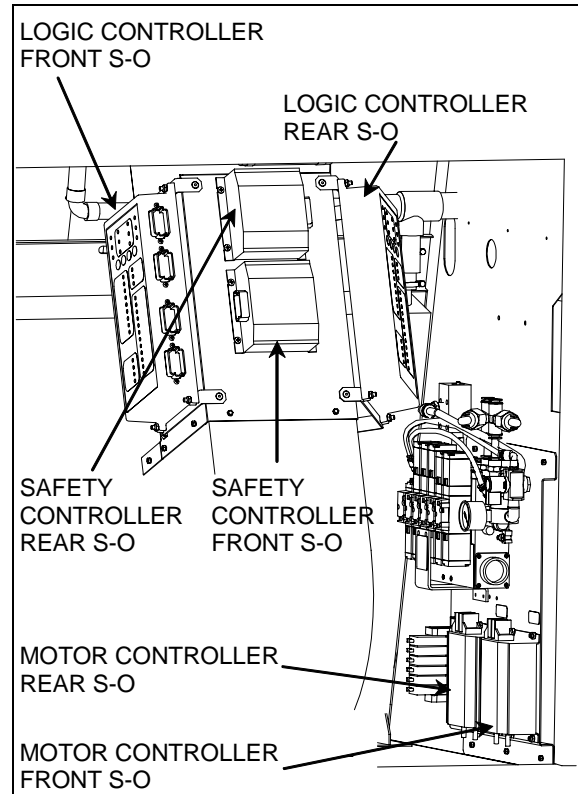

FIGURE 39 : SLIDE-OUT ELECTRICAL PANEL (FULL A/C)

13.3.1 Motor controller replacement

Caution: Be sure that all new motor controllers installed are identified with the part number #6000108 (front slide-out, Prevost #563318) or #6000109 (rear slide-out, Prevost #563319) to be compatible with the network logic controller module.

The procedure for replacement is the same for both motor controllers.

1. Turn the ignition key to the "OFF" position. For added security, trip the slide-out breakers (figure 41).
2. Take note of the electric cable localization and disconnect all of them from the motor controller.
3. Unscrew mounting nuts and remove the controller.

Caution: The power polarity must be respected to prevent permanent damage to the controller.

4. Reinstall the new motor controller by reversing the procedure.

- Take note of the new serial number with revision (RV:) and version (V:) identifications to inform Prevost service department for controller tracking.

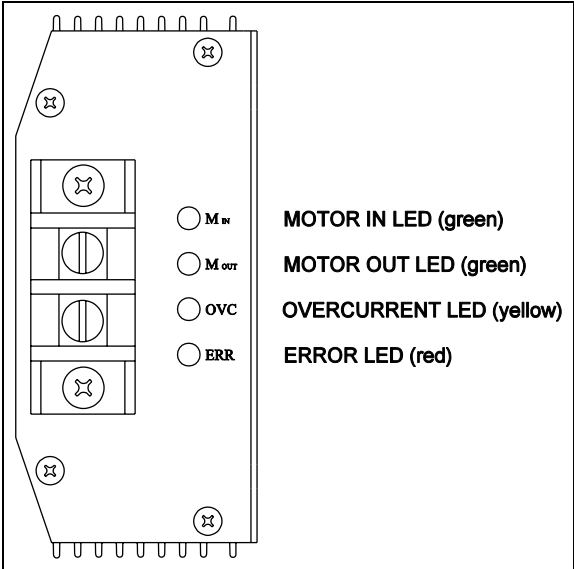

FIGURE 40 : MOTOR CONTROLLER LED PANEL

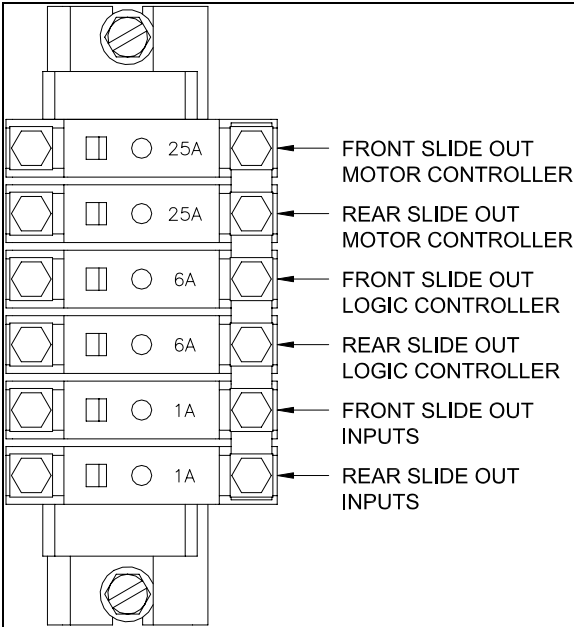

FIGURE 41 : SLIDE-OUT BREAKERS

Section 26: VIP SLIDE-OUT

13.3.2 Logic controller replacement

The procedure is the same for both slide-out logic controllers.

1. Turn the ignition key to the "OFF" position. For added security, trip the slide-out breakers (figure 41).
2. Disconnect all cable connectors located on the right side of the logic controller.
3. Loosen the two retaining nuts at the base of the controller. Unscrew the two nuts at the top of the controller.
4. Take note of the electric cable location. Remove the used logic controller and replace it by a new one.
5. To reinstall the new logic controller, reverse the procedure.
6. Take note of the new serial number with revision (RV:) and version (Vpr: and Vcl:) identifications to inform Prevost service department for controller tracking.
7. Reset all breakers to power on the slide-out controllers.

13.3.3 Safety controller replacement

The procedure is the same for both slide-out safety controllers.

1. Turn the ignition key to the "OFF" position. For added security, trip the slide-out breakers (figure 41).
2. Disconnect the connector located on the right side of the logic.
3. Loosen two metal screws on one side of the controller. Unscrew the other side screws. Remove the used safety controller and replace it by a new one.
4. To reinstall the new safety controller, reverse the procedure.
5. Take note of the new serial number with revision (RV:) to inform Prevost service department for controller tracking.
6. Turn the ignition key to the "ON" position. Reset all breakers to power on the slide-out controllers.

13.3.4 Downloading program

The program of the logic controller may be changed if necessary. The new program may be transferred to the logic controller by using a computer and a downloading kit made by the controller manufacturer.

Network link procedure:

1. Turn the ignition key to the "OFF" position.
2. Install the network inter-connection ("Y" wiring connection with 3 CPC connectors) between communications wiring of a motor controller. Those communication connectors (CH46 and CH47) are located below or next to the motor controllers.
3. Install the power wiring of the communication module (black box). Connect the red alligator terminal to the screw of the last breaker (1 amp) and ground the black alligator terminal to the chassis.
4. Link the communication module to the computer DB9 serial port.
5. Turn the ignition key to the "ON" position.
6. Retract and close both slide-out to prevent any errors.

Program downloading procedure:

1. Start "Visionplex" software. Execute "visionplex.exe" by opening the file beginning by "ich3174" and ending by ".VEH" extension.
2. Enter User PassWord "p" or the one that has been configured.
3. Select the program type to download. In the "Network menu", select "Client Code".
4. Select the logic controller module you wanted to change. The front slide-out module is ECU01 and the rear slide-out module is ECU03. In the "Module menu", select one of those ECU numbers. A window appears and displays the status of all the inputs and outputs of the controller.

Note: The inputs and outputs of the logic controller module have to be highlighted (square in line with the input/output). A highlighted color

means that the module and the Visionplex software are connected and the network communication is correct.

5. In the ECU module window, click the right mouse button. Then in the menu, select "Download Code". The "ProgFlashRom" window will appear.
6. In the right top corner of the "ProgFlashRom" window check the proper ECU number identified by "M: XX" (XX is the ECU number). Click on the ECU number with the right mouse button to modify.
7. Click the "#" button located on the top left corner. The "Configuration" window will appear. Click "Browse" button to select the program file to download in Flash-Rom (file ending by ".hex" extension). Click "Open" button and "Ok" to confirm the selection.
8. Click the "Erase" button. If the controller communication LED stop blinking, it means that the logic controller module have accepted the command. If the command is not working, try again.
9. Click the "Read" button to check if the flash has been erased. The green squares represent memory space. Wait until the end of the command.
10. Click the "WRITE" button. Wait until all the squares become blue (about 3 to 5 minutes). If you see one or many purple squares (bad memory), return to step 8. At the end of the writing step, the module is reset and the inputs and outputs squares become again highlighted.
11. Run tests using the slide-out control switch (automatic cycle) to be sure everything goes right.

13.4 SLIDE-OUT POSITION SENSORS

Two different types of sensors are used on each slide-out to define end limit and to keep track of the slide-out position. The "limit in" sensor detects two permanent magnets fixed on the slide-out underbody. The tooth sensor counts the pinion gear teeth to indicate the slide-out position to the slide-out logic controller (figure 42 and figure 43).

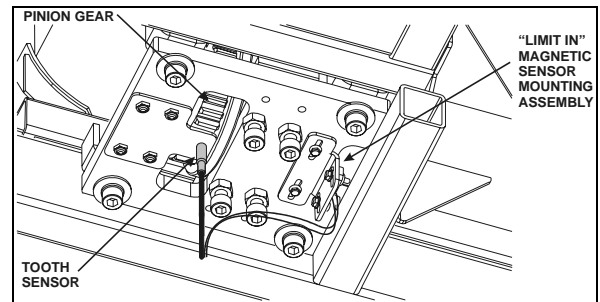

FIGURE 42 : FRONT SLIDE-OUT SENSORS

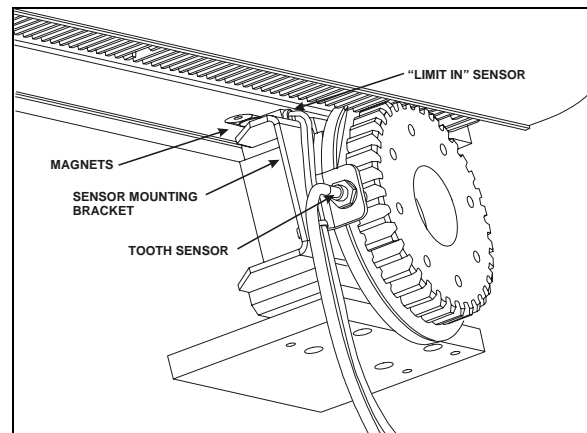

FIGURE 43 : REAR SLIDE-OUT SENSORS

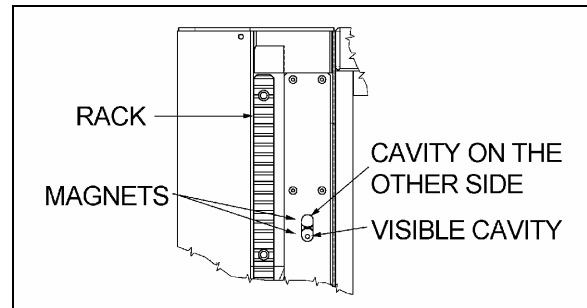

FIGURE 44 : MAGNETS ON SLIDE-OUT UNDERBODY

13.4.1 Maintenance and adjustment

The rear slide-out sensors are accessible from the inside of the vehicle while the front slide-out sensors can be reached from the 4th baggage compartment door. To replace the front slide-out "limit in" sensor, unscrew the mounting bracket from the pillow block supporting plate. The front slide-out tooth sensor can be unscrewed directly from its mounting bracket. Both rear slide-out sensors are mounted to the same bracket. To replace the sensors, remove the mounting bracket first. The tooth sensor can be unscrewed from the mounting bracket. Unsnap the "limit in" sensor to remove it.

Section 26: VIP SLIDE-OUT

The tooth sensor stable sensing distance is less than 0.118" (3mm). If the red LED is lit, the distance is not correctly adjusted and the sensor cannot detect the pinion teeth. With a pinion tooth directly in front of the sensor, screw the sensor into the threaded support until the LED turns green and remains stable. If the "limit in" sensor needs adjustment, just loosen the mounting bracket screws and slide the bracket.

14. SLIDE-OUT EXTERIOR FINISHING PANELS

Note: The removal and installation procedures are all based on standard service methods described in the body section of the Prevest maintenance manual. Refer to Prevest manual for procedures, tools, cleaner, adhesives and other product needed.

14.1 SIDE PANEL REMOVAL

Use the same procedure as described in the body section of Prevest service manual for MTH side panel removal, and:

- Keep the slide-out retracted and all pins locked;
- Make sure not to damage the finishing molding supports to be able to re-use them;
- Remove the old adhesive on the finishing molding supports and clean them before re-using;
- Check where adhesive, sealant and double face adhesive tape are on the structure and the panel back side, in order to be able to stick the new panel in the same way;
- Check the tape width and use same width tape when installing new panels.

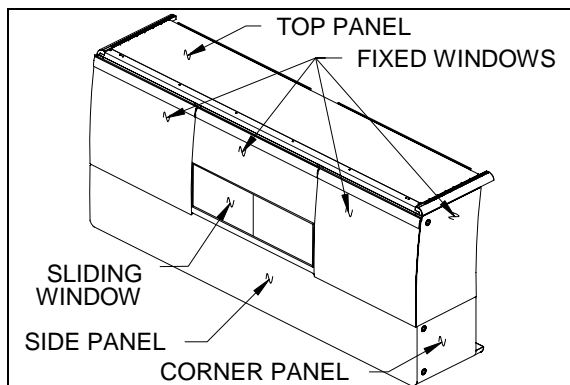

FIGURE 45 : SLIDE-OUT PANELS AND WINDOWS

14.2 SIDE PANEL INSTALLATION

For surface cleaning, and preparation, panel installation and products needed, use the same procedure as the MTH side panel installation described in Prevest service manual, and:

- Keep the slide-out retracted and all pins locked for panel alignment;
- Make sure to apply sealant between the side panels and the corner panels, and also between side panels and bottom and top panels. Apply sealant both inside and outside the slide-out panels.

14.3 CORNER PANELS REMOVAL

Note: The corner panels are made of aluminum, or of stainless steel in option.

Caution: Be careful not to damage the adjacent surfaces.

1. Remove the slide-out as described in section 1.3 and 1.5.
2. Remove all the pin receptacles as described in section 2.5.2.
3. Remove the fixed windows from the slide-out as described in section 15.1.
4. Remove panel upper rivets (figure 46) and lower rivets (figure 47) with a 1/8" drill bit, a hammer and a punch.
5. Insert a flat screwdriver between the panel and the slide-out structure, in the top left and right corners of the panel, and unstick the panel from the structure.
6. Use C-clamp to peel the panel from the slide-out structure.

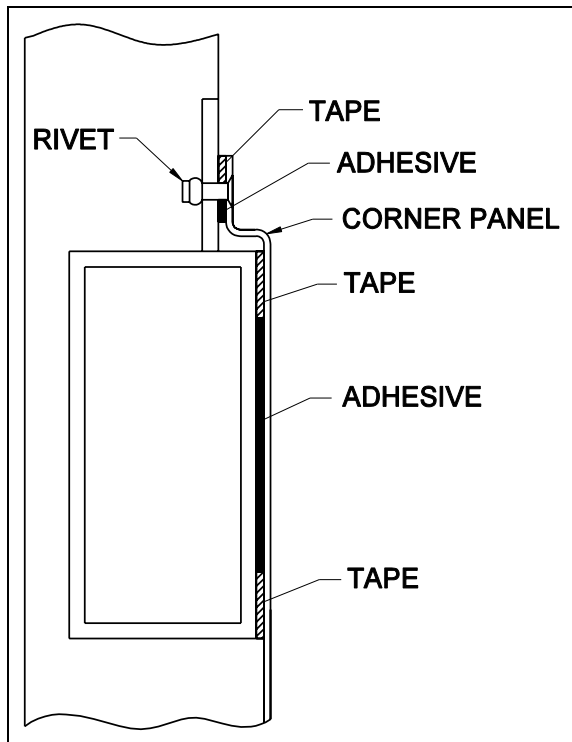

FIGURE 46 : CORNER PANEL INSTALLATION – UPPER PART

7. Check where adhesive, sealant and double face adhesive tape are on the structure and the panel back side, in order to be able to stick the new panel in the same way.
8. Check the tape width and use same width tape when installing new panels.

Caution: Make sure the heat gun nozzle tip is at least 4" from surface.

9. Use a heat gun and putty knife to remove the dried off adhesive and tape residue from the structure.

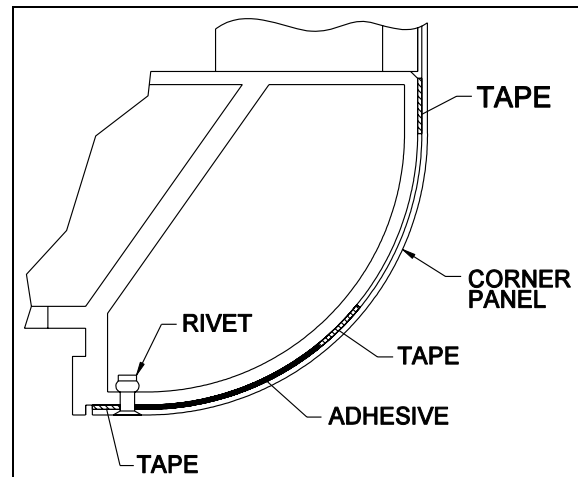

FIGURE 47 : CORNER PANEL INSTALLATION – LOWER PART

Warning: Because of the adhesive toxicity, never use a buffer or other sanding method to remove it.

14.4 CORNER PANELS INSTALLATION

Note: The corner panels are made of aluminum, or of stainless steel in option. Use rivet of same material as the panels.

For surface cleaning and preparation, panel installation, and products needed, refer to the MTH side panel installation procedure described in Prevost service manual, and:

- Protect adjacent surfaces with appropriate material;
- Make sure to apply sealant between the pin receptacles and the corner panels (figure 16 and figure 17);
- Make sure to apply adhesive around the pin receptacle
- Cut in the panel before installing the panel on the slide-out (figure 16 and figure 17);
- Refer to figure 46 and figure 47 for adhesive, tape and rivet position.

14.5 TOP AND BOTTOM PANELS REMOVAL

Note: The top and bottom panels are made of aluminum sheets.

Section 26: VIP SLIDE-OUT

1. Remove the slide-out as described in section 1.3 and 1.5.
2. Remove panel rivets with a 1/8" drill bit, a hammer and a punch (figure 48).
3. Insert a flat screwdriver between the panel and the slide-out structure, and unstick the panel from the structure.
4. Use C-clamp to peel the panel from the slide-out structure.
5. Check where adhesive, sealant and double face adhesive tape are on the structure and the panel back side, in order to be able to stick the new panel in the same way.
6. Check the tape width and use same width tape when installing new panels.
7. Use a heat gun and putty knife to remove the dried off adhesive and tape residue from the structure.

Warning: Because of the adhesive toxicity, never use a buffer or other sanding method to remove it.

14.6 TOP AND BOTTOM PANELS INSTALLATION

Note: The top and bottom panels are made of aluminum sheets and need aluminum rivet.

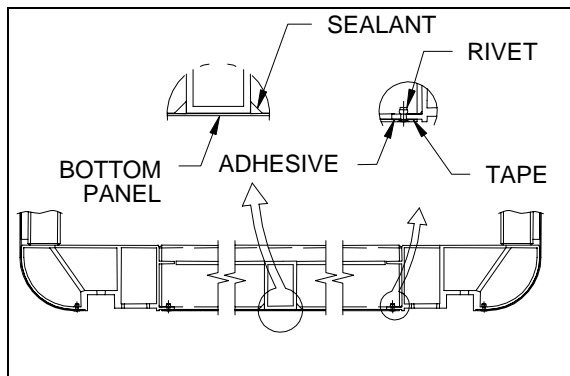

FIGURE 48 : TOP AND BOTTOM PANEL INSTALLATION

For surface cleaning and preparation, panel installation, and products needed, refer to the MTH side panel installation procedure described in Prevost service manual, and:

- Protect adjacent surfaces with appropriate material.

- See figure 48 and figure 49 for both bottom and top panel adhesive, sealant and tape position.

15. SLIDE-OUT FIXED, AWNING AND SLIDING WINDOWS

Note: The removal and installation procedures are based on standard service methods described in the body section of the Prevost maintenance manual. Refer to these procedures for tools and adhesives specifications.

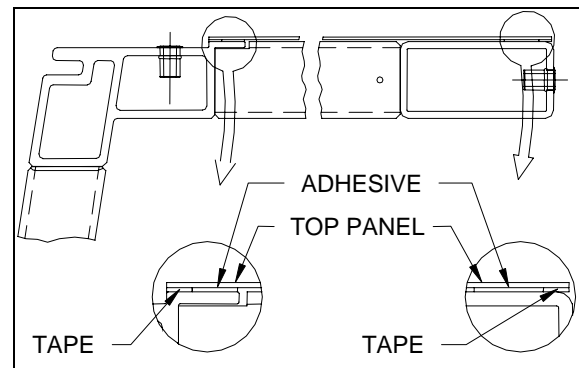

FIGURE 49 : TOP PANEL INSTALLATION

Warning: Always wear safety equipment when working with glass and chemical adhesives.

15.1 WINDOWS REMOVAL

1. Remove the slide-out as described in section 1.3 and 1.5.
2. If needed, remove the exterior extrusion as described in section 12.4.1 step 3.

Caution: Be careful not to damage the adjacent surfaces.

3. With a knife or a wire, cut the sealant and the adhesive between the windows and the structure. Make sure not to damage the rubber seal between the windows.
4. With a helper, remove the window from the slide-out.

For awning and sliding windows: unscrew the window frame from the structure, and cut the sealant. Remove the window.

15.2 WINDOWS INSTALLATION

Refer to procedures described in Prevest maintenance manual. Refer to figure 50 for tape, sealant and adhesive position.

1. Clean and prepare the windows and the slide-out structure surfaces with appropriate cleaner, abrasives and primers.
2. Apply appropriate double face self adhesive tape on the slide-out structure (figure 50).
3. Apply appropriate adhesive on the slide-out structure surfaces.

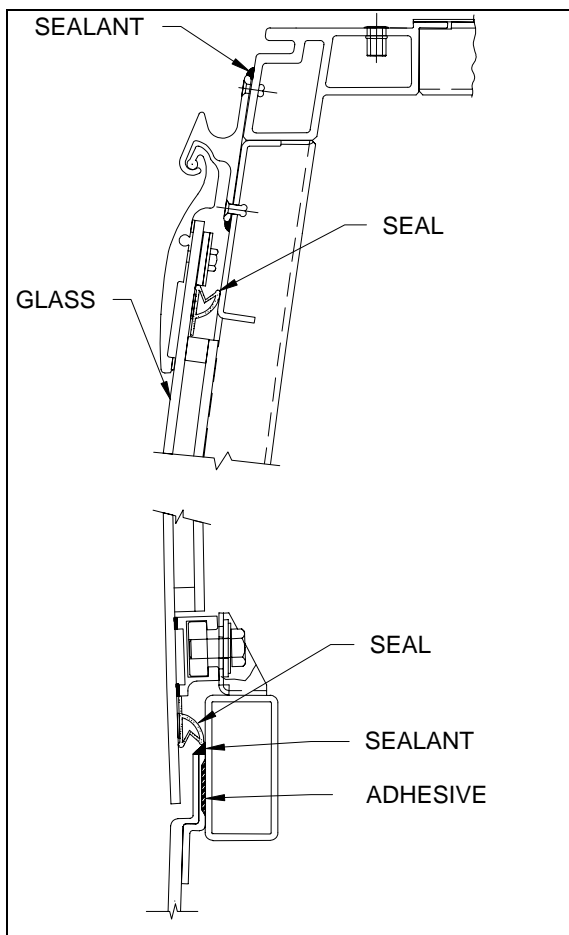

FIGURE 50 : WINDOWS ABOVE SIDE PANELS

4. Install the windows on the slide-out. Press the jigs on the windows and wait for the adhesive to dry.

For awning and sliding windows: install the window in its frame and screw it. Wait for the adhesive to dry.

5. From inside the slide-out, apply appropriate sealant between the windows and the structure.
6. Install the exterior extrusion as described in section 12.4.1 step 5.
7. Install the finishing molding supports and the molding.

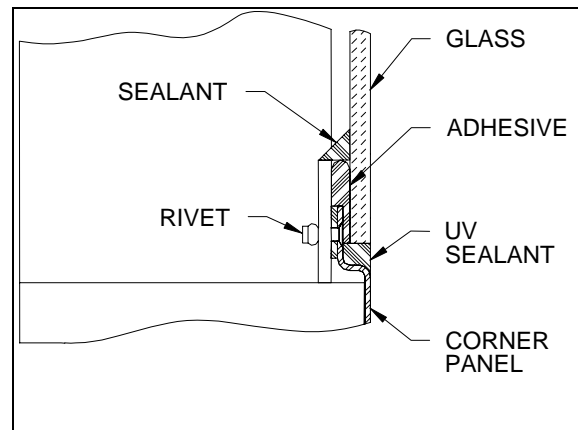

FIGURE 51 : WINDOW LOCATED OVER THE CORNER PANEL

16. WELDING PRECAUTION

Disconnect logic controller wiring connectors, the ground wire (black), and trip all breakers (figure 41).

Disconnect motor controller ground wire (black).

Refer to the welding precaution section in the maintenance manual.

Section 26: VIP SLIDE-OUT

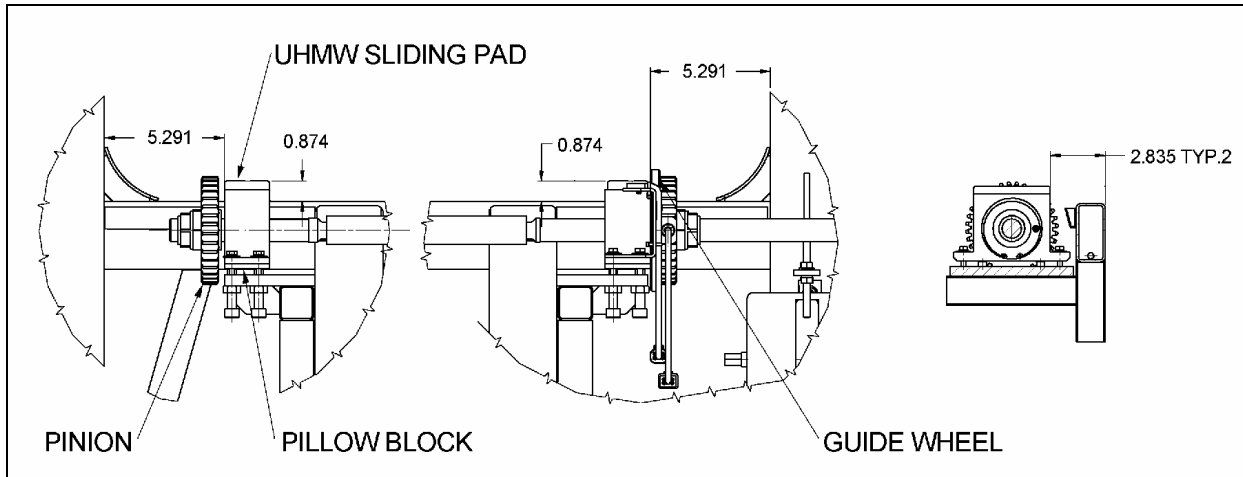

FIGURE 52 : PINION & PILLOW BLOCK ADJUSTMENT, REAR SLIDE-OUT (DIMENSIONS IN INCHES)

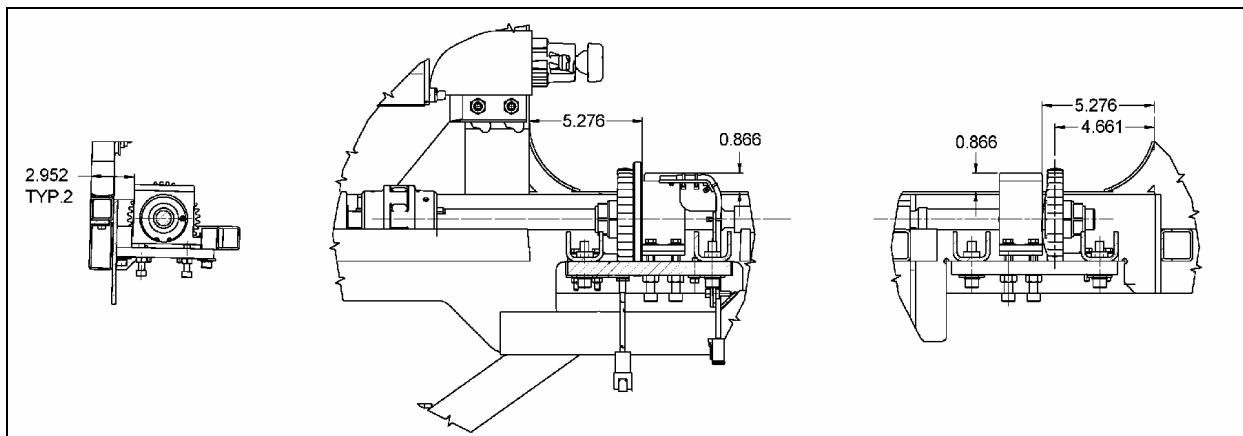

FIGURE 53 : PINION & PILLOW BLOCK ADJUSTMENT, FRONT SLIDE-OUT (DIMENSIONS IN INCHES)

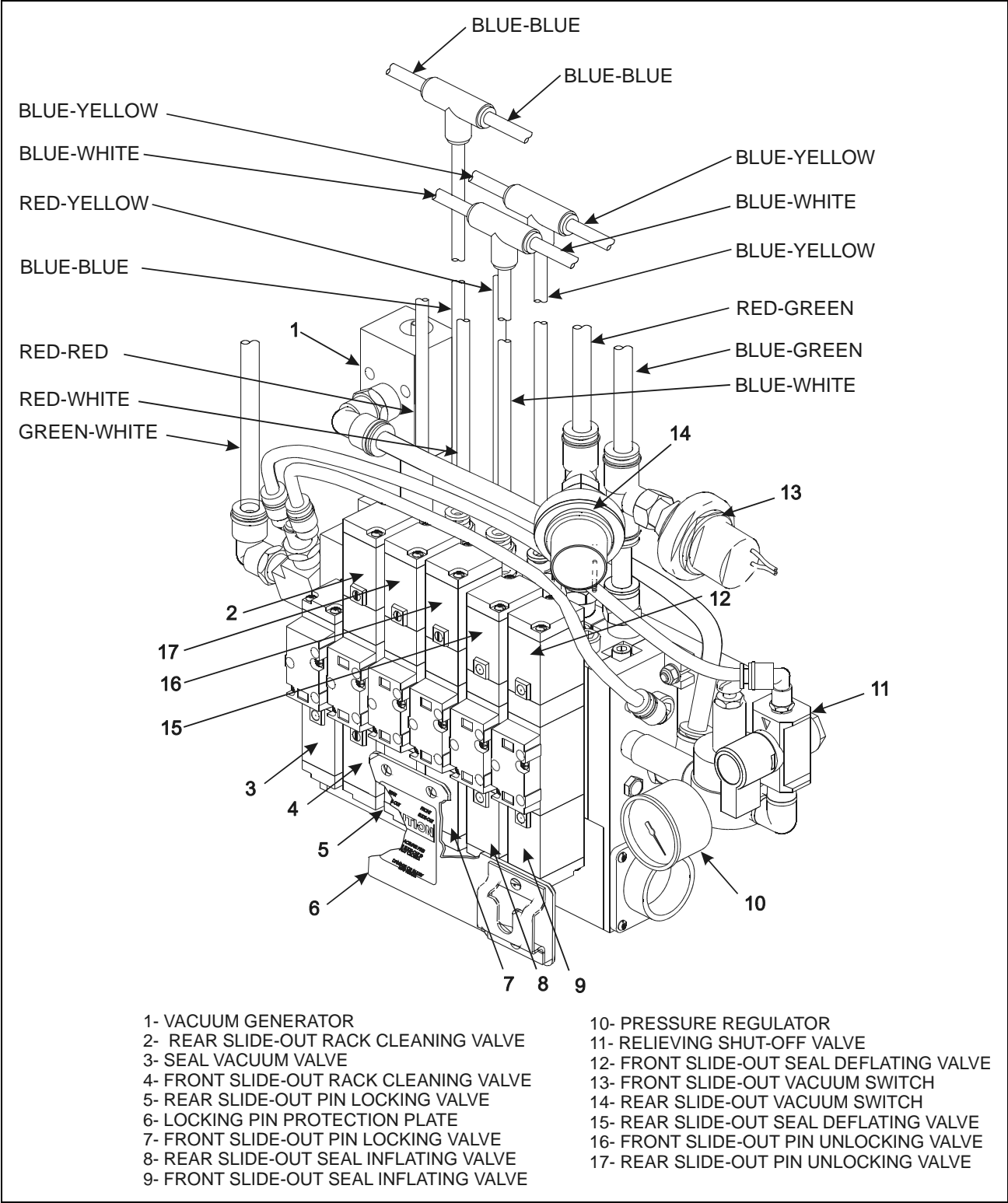

FIGURE 54 : PNEUMATIC COMPONENT PANEL

Section 26: VIP SLIDE-OUT

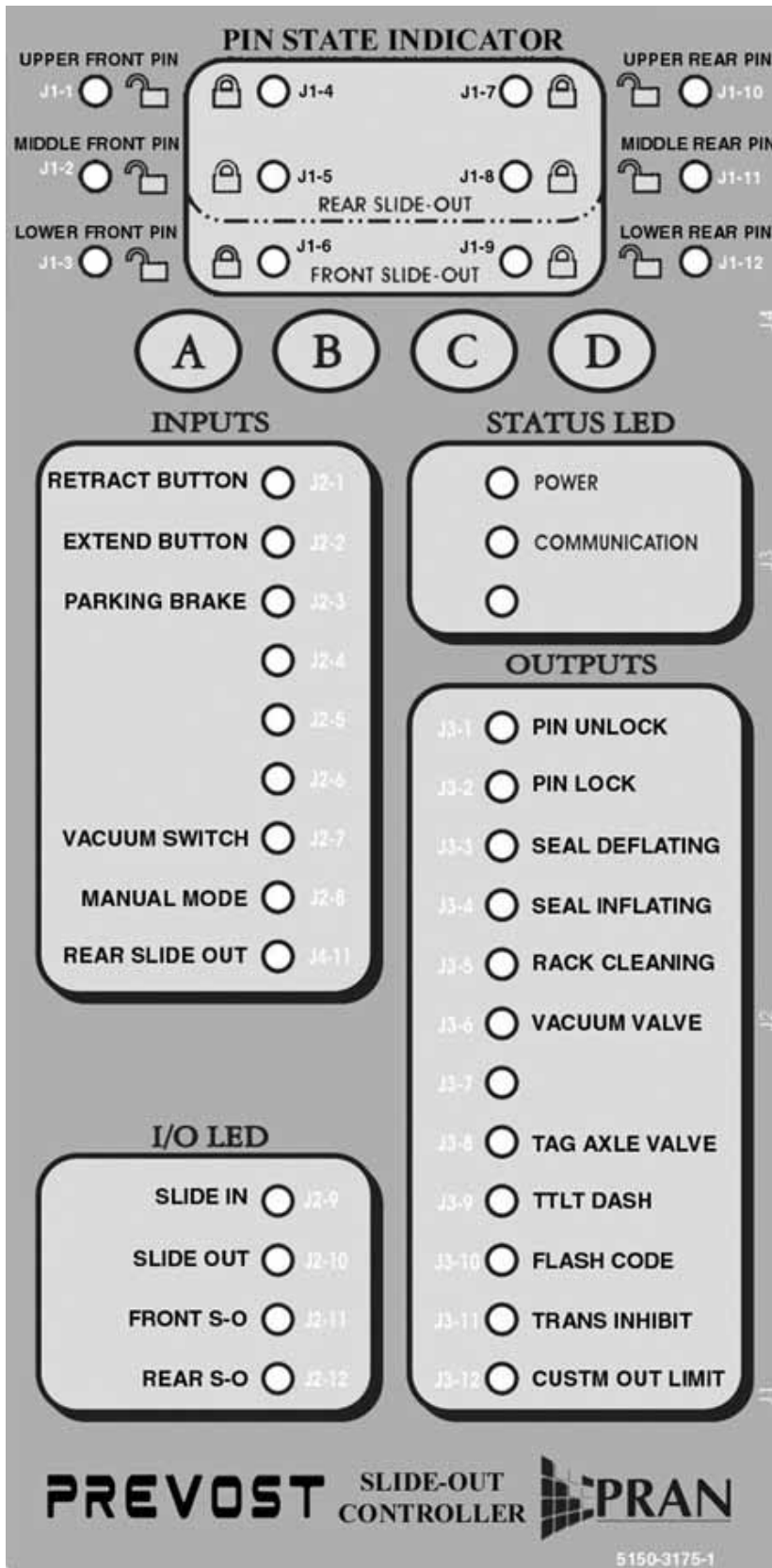

FIGURE 55 : SLIDE-OUT LOGIC CONTROLLER LED PANEL

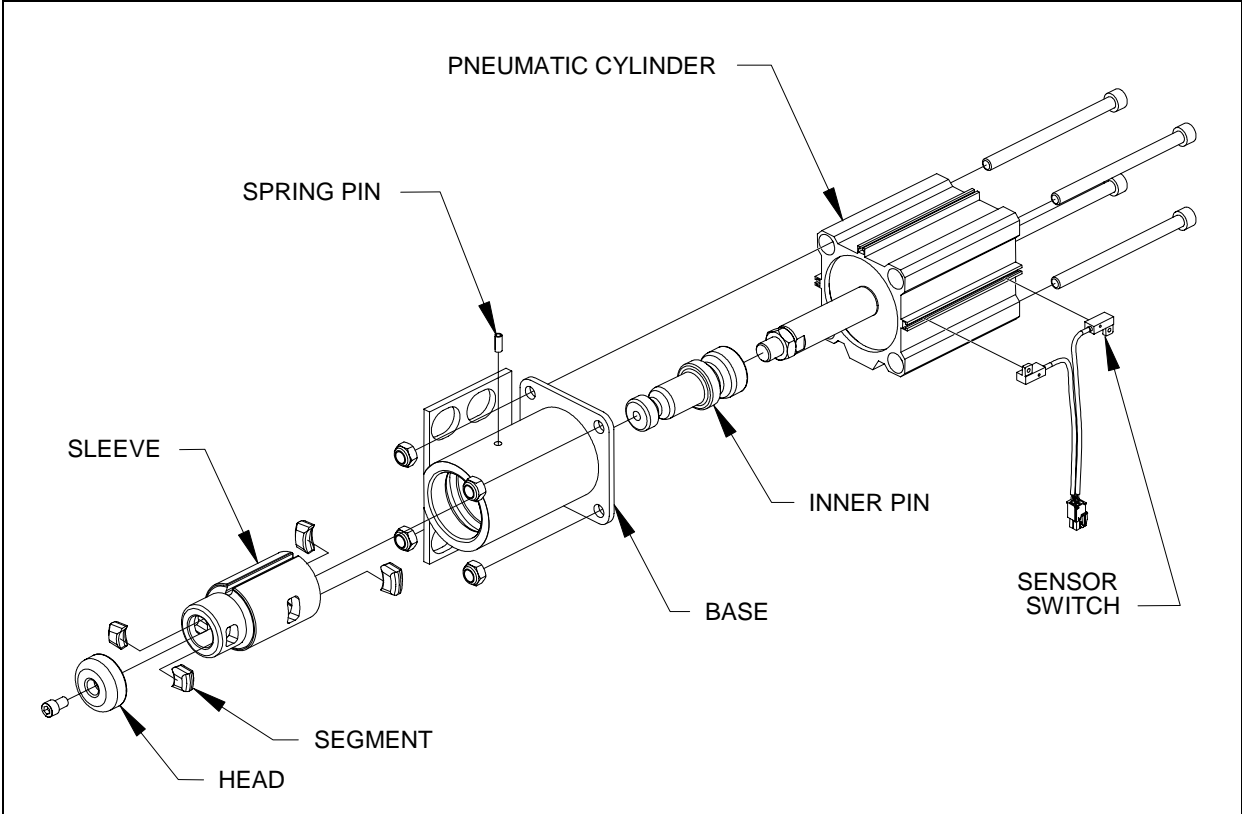

FIGURE 56 : LOCKING PIN ASSEMBLY

17. TROUBLESHOOTING

17.1 SLIDE-OUT CONTROL SWITCH AND TELLTALE LIGHT ON VEHICLE DASHBOARD

The flash codes are either displayed on the dashboard (telltale panel), on the handheld control or on the logic controller with the output LED identified "Flash Code".

In a case where both the front and rear slide-out are in error and flashing error codes on their respective remotes, the dash telltale will flash the front slide-out error code.

A flash code consists of two consecutive series of blinks separated by a one-and-one-half second pause. The first series of blinks identifies the first digit of the error number and the second series of blinks identifies the second digit of the error number. The flash code repeats itself after a pause of 4 seconds. All flash codes except 12, 31, 32 and 33 are repeating themselves for ever until cleared with the Ignition turned OFF and ON. The codes 12, 31, 32 and 33 will repeat three times and then stopped

Examples of codes:

Code #12

flashes 1 time, pause of 1,5 seconds, then flashes 2 times, pause of 4 seconds.

Code #23

flashes 2 times, pause of 1,5 seconds, then flashes 3 times, pause of 4 seconds.

Warning: If the dash slide-out telltale light starts blinking while on the road for 30 minutes, it means that one of the structural pins (4 bottom pins for the front slide or 2 bottom pins for the rear slide) is not properly inserted. Driving for a long period in this condition can damage the vehicle structure.

Caution: If the dash slide-out telltale light comes ON and stays ON (no blink) after 30 minutes on the road, it means that one of the 2 upper pins (not structural) are not properly inserted. Driving with the upper pins not inserted will not cause damage to the vehicle structure.

Clearing the flash code blink

Turning the ignition OFF and ON again, will stop the flash code blinking.

Bringing back the last flash code

Press and hold the handheld control rocker switch to the IN or OUT position for 2 seconds to see again an active flash code error that was cleared by turning the Ignition OFF and ON.

Code description

SIGNAL	PROBLEM	CAUSE	CORRECTIVE ACTION
Code #12	The slide-out does not extend or retract	The parking brake is not seen as being active by the controller	Make sure the parking brake is applied Confirm parking brake application with the parking brake light on the telltale panel Check wiring
Code #13	The seal deflates but the slide-out does not extend or retract	Problem with the vacuum switch sensor or the seal deflating valve	Visually inspect the seal to confirm that it is deflated If seal deflates, check/replace the vacuum switch If seal does not deflate, check the seal deflating valve

Section 26:VIP SLIDE-OUT

SIGNAL	PROBLEM	CAUSE	CORRECTIVE ACTION
Code #14	The seal deflates but the slide-out does not extend	The controller does not see all pins unlocked	Safety module not present or disconnected One of the unlock sensor wrongly positioned or broken Pin unlock valve defective
Code #21	When extending, the slide-out stops after having extended by 1 inch	The limit IN sensor is seen as active by the controller	Check the limit IN sensor
Code #22	When retracting, the slide-out went too far	The limit IN sensor is always seen as inactive by the controller	Check the limit IN sensor
Code #23	When extending, the slide-out stops after having extended by 8 inches	The controller does not see the tooth sensor	Check the tooth sensor
Code #24	The slide-out does not move out	Problem with the slide-out motor or motor drive controller module	Ensure the motor breaker is not tripped Check/replace the motor drive
Code #25	When retracting, the slide-out does not move at all or moves by 8 inches and stops	Tooth sensor not seen by the controller or a problem with the motor drive module or the motor itself	Check that the motor breaker is not tripped Check/replace the tooth sensor Check/replace the motor drive module
Code #26	The slide-out retracts but refuses to pin	The slide-out position has been moved manually, mixing-up the tooth sensor	Use the manual procedure to re-pin, it will reset the counter. If this problem comes back, check the tooth sensor adjustment
Code #31	One of the unlock sensor is defective and needs repair. No immediate impact on the slide-out operation	One of the unlock sensor is always seen active even when the pins are locked	Check the unlock sensors
Code #32	One of the lock sensor is defective and needs repair. No immediate impact on the slide-out operation	One of the lock sensor is always seen as active	Check the lock sensors
Code #33	The slide-out stopped in overcurrent	There is abnormal friction in the slide-out movement or the slide-out mechanical stopper before reaching full extension	Check the mechanical slides

Section 26: VIP SLIDE-OUT

SIGNAL	PROBLEM	CAUSE	CORRECTIVE ACTION
Code #41	The slide-out is not working properly	The front and the rear logic controllers have the same ECU number	Check the wiring of the rear module, to make sure the input J4-11 is ON.
Code #42	The slide-out does not extend or retract	The battery voltage is too low	Start the engine and set the RPM to fast idle Connect to a battery charger capable to supply 40 Amps

17.2 MOTOR CONTROLLER

The motor controller has 4 LED to show the controller activity and indicate errors (FIGURE 40). The error LED flashes once every 3 seconds when the controller is in operation. When retracting the slide-out, the "Motor In" LED comes on, and when extending the slide-out, the "Motor Out" LED comes on. When the motor is in motion activity, the error LED is disabled. In that state, if a communication error is detected, the motor is stopped 2 seconds after the detection.

SIGNAL	PROBLEM	CAUSE	CORRECTIVE ACTION
No flash on the ERR LED	A. No problem (the motor is in motion) B. Module error	A. - B. The module is not plugged	A. - B. Plug the module
Normal Error LED flashing (1 time every 2 seconds)	No problem		
"Error" LED fast flashing: two flashes every second	Communication error	A. Bad electrical connection with the logic controller; B. Logic controller turned off or defective;	A. Check the communication cable between the two controllers. B. Check the logic controller condition.
Error LED: one long flash every three seconds 1.5 sec ON .2 sec OFF	Electric motor or controller error	A. Opened connection to motor or power supply cable damaged B. Defective power transistor. C. Motor defective; D. Safety controller defective or bad electrical connections.	A. Check the power supply cable between the controller and the motor. B. Change the motor controller. C. Check the motor condition and replace if necessary (see section). D. Check the safety controller and the electrical connections conditions. Change the safety controller if necessary
"Overcurrent" LED comes on and stays on only one second.	Software protection activated	Software overcurrent detected (threshold at 34 A): A. Excessive weight; B. Obstruction to the slide-out movement; C. Mechanical component failure; D. Motor controller defective;	A. Reduce the weight in the slide-out. B. Remove any obstacle that may obstruct slide-out movement. C. Check the mechanical component condition. D. Change the motor controller (refer to section 13.3.1).
"Overcurrent" LED and "Error" LED come on and stays on only one second.	Hardware protection activated	Hardware overcurrent detected (threshold at 40 A): A. Excessive weight; B. Obstruction to the slide-out movement; C. Mechanical component failure;	A. Reduce the weight in the slide-out. B. Remove any obstacle that may obstruct slide-out movement. C. Check the slide-out driving component condition.

Section 26: VIP SLIDE-OUT

SIGNAL	PROBLEM	CAUSE	CORRECTIVE ACTION
		D. Motor controller defective; Overheat detected (threshold at 120°C): E. Controller internal temperature over 120°C (248°F).	D. Change the motor controller (refer to section 13.3.1). E. Check the controller compartment for abnormal temperature. Reset the power on the controllers.

17.3 SLIDE-OUT OPERATION

PROBLEM	CAUSE	CORRECTIVE ACTION
Slide-out does not retract or extend when depressing the control switch.	A. Driving mechanism failure; B. Electrical problem;	A. Check driving mechanical components. B. Refer to section 17.1 to 17.2.
Slide-out is not straight when retracting or extending.	A. Slide-out inner stopper loosened or not correctly aligned; B. Slide-out exterior extrusion interference with structure; C. Pinion bad synchronization (pinion keyless bushing loosened); D. Pinion keyless bushing slipping; E. Driving mechanism failure;	A. Check stopper adjustment and condition (refer to section 1.1.2). B. Check exterior extrusion and roof reinforcing rod adjustment (refer to section 1.2 and section 3). C. Tighten or re-synchronize the pinion (refer to section 5.6). D. Change faulty keyless bushing (refer to section 5). E. Check driving mechanical components.
Slide-out is not straight once retracted or extended.	A. Pinion bad synchronization or absence of synchronization after significant load variation;	A. Re-synchronize the pinion (refer to section 5.6).
Slide-out vibrating when extending or retracting.	A. Upper racks worn or damaged; B. Too many shims on upper shaft pillow block; C. UHMW sliding pad worn or damaged; D. Objects in upper racks;	A. Replace the upper racks (refer to section 4.2). B. Remove shim and readjust the pillow block (refer to section 5.2). C. Replace the UHMW sliding pad (refer to section 10.2). D. Clean the upper racks and check the rack cleaning air nozzle orientation and condition.
Transmission DRIVE range or REVERSE cannot be selected.	A. No locking pin locked on either slide-out; B. No air pressure in the cylinder pins of both slide-out; C. No air pressure in the slide-out pneumatic system;	A. Check the information given by the logic controller LED section "Pin state indicator" (refer to figure 55). B. Check pin valve operation on both slide-out () C. Check the slide-out air pressure inlet valve condition and the accessory air tank pressure.
Watertightness problem	A. Inflatable seal and/or wiper seal damaged or unstuck; B. Insufficient air pressure in the seal; C. No air pressure in the slide-out pneumatic system; D. Sealant missing;	A. Check both seals condition. B. Check the pressure regulator, the relieving shut-off valve and the seal valve condition. C. Check the slide-out air pressure inlet valve condition and the accessory air tank pressure. D. Check the racks, the exterior extrusion,

Section 26: VIP SLIDE-OUT

PROBLEM	CAUSE	CORRECTIVE ACTION
	<p>E. Windows or exterior panel damaged;</p> <p>F.</p>	<p>the windows and the exterior panels sealant condition. Check the racks and the exterior extrusion screws.</p> <p>E. Check the windows and exterior panels condition.</p>
<p>Inflatable seal damaged or removed, or wiper seal unstuck from the structure.</p>	<p>A. Slide-out retracted or extended with the manual procedure without having deflated the inflatable seal;</p> <p>B. Vacuum switch malfunction or bad set-up;</p> <p>C. Excessive load on roof or bad roof reinforcing rod adjustment;</p> <p>D. Guide wheel excessive wear;</p> <p>E. Plastic stopper bad adjustment;</p> <p>F. Seal valve malfunction;</p> <p>G. Excessive seal air pressure (over 10 psi);</p> <p>H. Excessive load in the slide-out;</p> <p>I. Slide-out not centered in the structure opening;</p> <p>J. Object or ice on the slide-out exterior panels;</p>	<p>A. Always deflate the seal when manually retracting or extending the slide-out.</p> <p>B. Check the vacuum switch condition for replacement or adjustment (refer to section 12.3).</p> <p>C. Readjust the roof reinforcing rod (refer to section 3).</p> <p>D. Replace the guide wheel (refer to section 5.7).</p> <p>E. Readjust the plastic stopper (refer to section 5.8).</p> <p>F. Check the seal valve condition.</p> <p>G. Check the air pressure regulator adjustment (refer to section 5.8).</p> <p>H. Respect the slide-out load capacity.</p> <p>I. Reinstall and readjust the slide-out in the vehicle.</p> <p>J. Remove ice and objects before retracting the slide-out.</p> <p>For all situations, check the seal condition. Refer to the seal section annexed for replacement.</p>

18. SPECIFICATIONS

18.1 SLIDE-OUT MAXIMUM LOAD

Front slide-out:

Maximum load (retracted or extended).....2000 lb
 Maximum load when moving.....1200 lb*

Rear slide-out:

Maximum load (retracted or extended)2000 lb
 Maximum load when moving.....1200 lb*

* When the load is distributed in the slide-out to prevent a deflection of the inside lower member over 1/4" that could damage the seal.

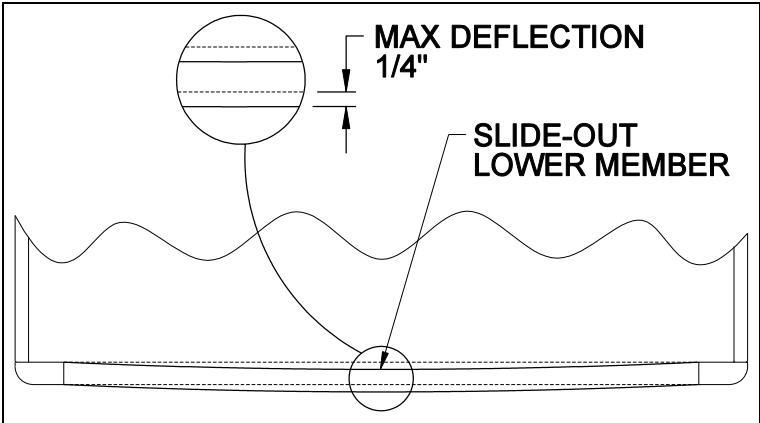

FIGURE 57 : FRONT SLIDE-OUT DEFLECTION

18.2 TRANTORQUE KEYLESS BUSHING

Make.....Fenner Drives
 Type.....Trantorque GT
 Shaft size.....1"
 Installation torque max.....125 lb-ft

WRENCHES FOR INSTALLATION

**Style C
Installation Nut**

Fenner Drives offers a complete line of high-quality crowfoot wrenches for installation and to provide counter-torque. These wrenches are much narrower than earlier designs and are specifically for use with Trantorque GT units. It is recommended that both wrenches be used when installing a Trantorque GT unit.

1/2" SQUARE DRIVE

Shaft Size	Part Number	Wrench Style	Dimensions (inches)			
			A	h	w	t
13/16 to 1	6202990024	C	1-1/2	3.44	2.75	0.75

FIGURE 58 : WRENCHES FOR KEYLESS BUSHING INSTALLATION

INSTALLATION INSTRUCTIONS

A Trantorque GT Keyless Bushing offers flexible and easy installation while providing exceptional holding power. To ensure a Trantorque GT unit performs as specified, it must be installed properly.

Warning: Use no lubricants in this installation.

1. Shaft and component bore must be within $\pm 0.003"$ ($\pm 0.08\text{mm}$) [$\pm 0.0015"$ ($\pm 0.04\text{mm}$) Mini Series] of stated bore diameter and must have a surface finish of 32-125 Ra (roughness average). If the surface finish is outside these specified values, consult Fenner Drives.

2. Both shaft and component bore must be completely free of paint, grease, oil, and dirt. If necessary, clean the surfaces with a non-petroleum based solvent, such as isopropyl alcohol.

Warning: Do not lubricate the Trantorque GT bushing or shaft. The use of any lubricant on the contact surfaces could result in bushing failure and will void all warranties.

3. Insert the Trantorque GT unit into the component to be mounted, making sure the mating hub is flush against the shoulder at the hex flats.

4. Position the assembly at the desired location on the shaft and hand-tighten the nut (clockwise) until the assembly becomes snug on the shaft.

Warning: Do not hammer or use any type of impact to force the Trantorque GT assembly along the shaft.

Warning: The shaft must fully engage the shaft gripping area (Figure 1) of the Trantorque GT unit. Figure 2 illustrates minimum shaft engagement.

5. Using a torque wrench, tighten the nut to the proper installation torque. See table for torque value. (Note: Fenner Drives has available crowfoot wrenches for square drives in sizes from 1/2" to 3-1/2".) The hex flats on the outer ring are provided for counter-torque, eliminating the need to hold the component or shaft while applying installation torque.

Note: At full installation torque, the assembly will have moved approximately $\pm 0.075"$ ($\pm 1.9\text{mm}$) [$\pm 0.045"$ ($\pm 1.1\text{mm}$) Mini Series] axially along the shaft away from the nut. If axial position is critical it may be necessary to loosen the nut and reposition the assembly.

Warning: Over-tightening the nut could damage the Trantorque GT unit and/or the mounted component.

Do not use an impact wrench in the installation.

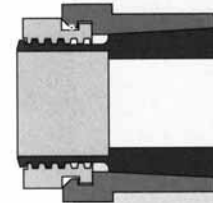

Figure 1

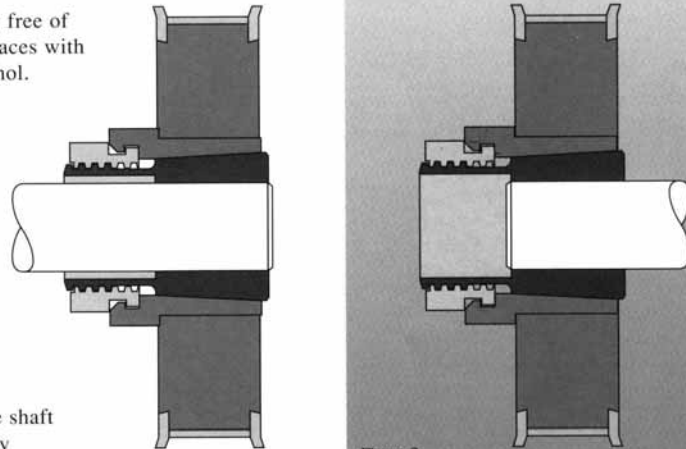

Figure 2

Installation Torque on Nut

	Inch Pound System		Metric System	
	Shaft Size	In. Lbs.	Shaft size	N-m
MINI SERIES	3/16-1/4	125	5-6mm	14.1
	5/16-3/8	150	7-9mm	17.0
	7/16-1/2	175	10-12mm	19.8
	9/16-5/8	200	14-16mm	22.6
	3/4	700	17mm	80.0
STANDARD SERIES	5/8-3/4	1200	15-19mm	136
	13/16-1	1500	20-25mm	170
	1-1/16-1-1/4	2000	28-32mm	225
	1-5/16-1-1/2	2300	34-38mm	260
	1-9/16-1-3/4	2800	40-42mm	316
	1-13/16-2	4900	45-50mm	554
LARGE SERIES	2-1/16-2-1/4	5300	55mm	600
	2-5/16-2-1/2	5600	60mm	635
	2-9/16-2-3/4	6000	65-70mm	680
	2-13/16-3	6600	75mm	750

FIGURE 59 : KEYLESS BUSHING INSTALLATION INSTRUCTION

18.3 SPEED REDUCTION GEARBOX

Make.....David Brown
 Type.....Series C Radicon helical worm gear
 Unit size.....C0320
 Ratio.....140 : 1

Lubrication

Oil grade.....6G (polyglycol synthetic)
 Temperature range.....14°F to 86°F
 Quantity.....0.6 Litres
 Oil change.....Lubricated for life

18.4 POSITION SENSORS

LIMIT IN SENSOR

MakeHoneywell
 TypeSeries SR13D-A1 Hall effect
 Supply voltage.....3.8 to 30 VDC
 Current consumption.....13 mA
 Operating temperature.....-40°C to 150°C

TOOTH SENSOR

MakeOmron
 TypeShort barrel inductive prox
 Part number.....E2E-X2D1
 Seeing distance.....2mm
 Size.....M8
 Supply voltage.....10 to 30 VDC
 Operating temperature.....-25°C to 70°C

18.5 RIGHT ANGLE DRIVE

Lower right angle drive

Make.....Curtis Machine
 Type.....Series 200M, spiral bevel gear
 Ratio for lower right angle drive.....1.5 : 1
 Ratio for upper right angle drive.....1 : 1

Lubrication

Oil grade.....AGMA 5EP
 Quantity.....Refilling cap level
 Oil change.....Every three years
 (If greaseLubricated for life)

18.6 ELECTRIC MOTOR

Make.....Leeson
 TypePermanent magnet 24 volts DC
 Power1/3 HP
 RPM.....1800
 Frame.....Nema S56C

18.7 LOGIC CONTROLLER

The heart of this unit is constituted of a micro-controller with a permanent memory in which the tasks of the function are implanted.

TECHNICAL AND PHYSICAL DESCRIPTION

- o Power supply range: 9 Vdc up to 32 Vdc;
- o 21 inputs configurable high side, low side or analog;
- o 12 high side outputs rated to 2A max.;
- o 4 input/output configurable high side, low side or analog input or high side output by serial network;
- o PWM of adjustable frequency is available on each outputs;
- o I/O and network activity status LED;
- o Reverse polarity protection included;
- o Programmable via serial network;
- o Flash technology microprocessor;
- o Operating temperature range -40°C to +85°C;
- o Thermal dissipation enhanced available;
- o Communication protocol: SAE J1708 (RS-485) or J1939.
- o 5 volts reference voltage available;
- o Protection against reversed polarity power connection, load dump occurrences, faulty ground connection and communication loss;
- o Splash proof and shock proof.

18.8 MOTOR CONTROLLER

This unit is a high pulsed current drive with PWM variable speed control. It is in communication with the logic controller.

TECHNICAL AND PHYSICAL DESCRIPTION

- o Power supply range: 15V DC up to 28V DC;

Section 26: VIP SLIDE-OUT

- Maximum output current drive: 30A (4 minutes continuous), 60A peak repetitive (20KHz);
- Variable speed capability with PWM drive;
- Hardware overcurrent protection: 40A;
- Programmable software overcurrent protection;
- Overheat protection: +85°C;
- Motor direction activity, overcurrent and network activity status LED;
- Communication protocol: SAE J1708 (RS-485);
- Operating temperature range: -40°C to 70°C.

18.9 ELECTRICAL CONTROL SWITCH

Type.....Momentary contract
(ON-OFF-ON)
Rating.....1A @ 28V DC

18.10 CONVERSION CHECKLIST

The converter should check these points before closing the walls covering the locking pins, the roof reinforcing rod and the pinions:

- Make sure all the pins are locking and unlocking properly by checking the pin sensor switches, the logic controller LED (see figure 55).
- Check that the front slide-out exterior panels are parallel with the vehicle panels when retracted. If not, re-synchronize the upper shaft pinion.
- Make sure the slide-out does not move when locking or unlocking the pins. If necessary, readjust the locking pins.
- Make sure the pin receptacle plastic caps are present and properly installed.
- Check that the slide-out is straight when completely extended, and that it leans against all inner stoppers.
- Make sure the vehicle upper member is parallel with the front slide-out structure. If not, readjust the roof reinforcing rod. This may be affected by the loading on the roof.

- Make sure the front slide-out lower member deflection is within 1/4". If not, redistribute the slide-out load.
- Check the whole slide-out mechanism good functioning. The slide-out should retract and extend smoothly without vibration.

Final check:

- Make sure the slide-out air pressure inlet valve is completely opened.
- Check the inflatable seal air pressure on the pressure regulator. The pressure should be between 7 and 10 psi.
- Clean the upper racks of any sand, dust or other foreign material. Check the rack cleaning air nozzle alignment and proper functioning