

# SECTION 23: ACCESSORIES

## CONTENTS

<b>1. AUDIO AND VIDEO SYSTEM DESCRIPTION.....</b>	<b>4</b>
1.1 AM/FM RADIO.....	6
1.1.1 VR300 AM/FM Radio / CD Player.....	6
1.1.2 Security Code.....	6
1.1.3 Removal.....	6
1.1.4 DELPHI Premium Satellite Radio AM/FM/MP3 CD stereo (OPTIONAL).....	7
1.2 VSS-04 SOUND SELECTOR.....	7
1.2.1 Removal.....	7
1.3 VD-404 MOBILE DVD PLAYER.....	8
1.4 MULTICHANNEL POWER AMPLIFIER VA400.8.....	8
1.5 SPEAKERS.....	8
1.6 VIDEO CASSETTE PLAYER (VCP).....	9
1.6.1 Removal.....	9
1.6.2 Installation.....	9
1.7 BOOM-TYPE MICROPHONE.....	9
1.7.1 Removal.....	9
1.7.2 Installation.....	9
1.8 HANDHELD PRIORITY MICROPHONE.....	10
1.9 WIRELESS MICROPHONE.....	10
1.10 TV TUNER.....	10
1.11 KARAOKE.....	10
1.11.1 Karaoke Panasonic Sound System – MOBILE DVD PLAYER DV1500.....	10
1.12 DRIVER'S SPEAKERS.....	10
1.13 MONITOR.....	11
1.14 SCENIC VIEWING SYSTEM.....	11
1.15 ROOF ANTENNA INSTALLATION.....	11
<b>2. HUBODOMETER.....</b>	<b>11</b>
2.1 DESCRIPTION.....	11
2.2 OPERATION.....	11
2.3 REMOVAL.....	12
2.4 INSTALLATION.....	12
<b>3. BACK-UP CAMERA AND MONITOR.....</b>	<b>12</b>
<b>4. COLD STARTING AID (ETHER).....</b>	<b>14</b>
4.1 PREVENTIVE MAINTENANCE.....	15
4.2 TROUBLESHOOTING (IF SYSTEM IS NON-FUNCTIONING).....	15
4.3 THERMAL CUTOUT VALVE QUICK TEST.....	15
<b>5. DESTINATION SIGN.....</b>	<b>16</b>
5.1 ELECTRONIC DESTINATION SIGN (OPTIONAL).....	16
<b>6. LAVATORY.....</b>	<b>16</b>
6.1 DESCRIPTION.....	16
6.2 MAINTENANCE.....	17
6.3 VENTILATION FAN.....	17
6.3.1 Description.....	17
6.3.2 Maintenance.....	17
6.3.3 Removal and Installation.....	17
6.4 DOOR LOCK.....	17

## Section 23: ACCESSORIES

---

6.5	LAVATORY LIGHT .....	18
6.6	LAVATORY NIGHT-LIGHT.....	18
6.7	EMERGENCY BUZZER.....	18
6.8	FRESH WATER TANK.....	18
6.8.1	<i>Fresh Water Tank Draining</i> .....	18
6.8.2	<i>Fresh Water Tank Filling</i> .....	20
6.9	LIQUID SOAP DISPENSER .....	20
6.10	FLUSH PUSH-BUTTON .....	20
6.10.1	<i>Pneumatic Timer Removal and Installation</i> .....	20
6.10.2	<i>Timer Adjustment</i> .....	20
6.11	FLUSH PUMP .....	21
6.11.1	<i>Flush Pump Removal</i> .....	21
6.12	SUMP TANKS .....	21
6.12.1	<i>Main Sump Tank Draining</i> .....	21
6.12.2	<i>Main Sump Tank Filling</i> .....	21
6.12.3	<i>Auxiliary sump Tank Draining</i> .....	21
<b>7.</b>	<b>AIR HORN VALVE .....</b>	<b>22</b>
7.1	AIR HORN VALVE MAINTENANCE.....	22
<b>8.</b>	<b>HEADLIGHTS CLEANING SYSTEM.....</b>	<b>22</b>
8.1	GENERAL DESCRIPTION .....	22
8.2	WASHER FLUID REFILLING.....	22
8.3	WASHER NOZZLES ADJUSTMENT .....	22
<b>9.</b>	<b>WINDSHIELD WIPERS AND WASHERS .....</b>	<b>23</b>
9.1	GENERAL DESCRIPTION .....	23
9.2	WIPER ARM .....	24
9.2.1	<i>Wiper Arms Positioning</i> .....	24
9.3	WINDSHIELD WIPER MOTOR.....	25
9.3.1	<i>Windshield Wiper Motor Replacement</i> .....	25
9.4	TROUBLESHOOTING .....	26
<b>10.</b>	<b>TIRE PRESSURE MONITORING SYSTEM (TPMS) .....</b>	<b>27</b>
10.1	TIRE VALVE INSTALLATION.....	27
10.2	BERU SENSORS INSTALLATION .....	28
<b>11.</b>	<b>AUTOMATIC FIRE SUPPRESSION SYSTEM (AFSS) (OPTIONAL) .....</b>	<b>29</b>
11.1	PERIODIC MAINTENANCE .....	29
<b>12.</b>	<b>SPECIFICATIONS .....</b>	<b>32</b>

## ILLUSTRATIONS

FIGURE 1 : AUDIO-VIDEO PANEL .....	4
FIGURE 2: AUDIO & VIDEO CONNECTIONS .....	5
FIGURE 3: RACKS ON AUDIO-VIDEO PANEL .....	6
FIGURE 4: AUDIO-VIDEO PANEL .....	6
FIGURE 5: VR300 CD/AM/FM STEREO RECEIVER .....	6
FIGURE 6: DELPHI PREMIUM SATELLITE RADIO .....	7
FIGURE 7: VSS-04 SOUND SELECTOR .....	7
FIGURE 8: VD-404 MOBILE DVD PLAYER .....	8
FIGURE 9: MULTICHANNEL POWER AMPLIFIER .....	8
FIGURE 10: CROSSOVER ADJUSTMENT .....	8
FIGURE 11: 10CM DUAL CONE SPEAKER .....	9
FIGURE 12: V3000 VIDEO CASSETTE PLAYER .....	9
FIGURE 13: BOOM-TYPE MICROPHONE .....	9
FIGURE 14: HANDHELD PRIORITY MICROPHONE .....	10
FIGURE 15: WIRELESS MICROPHONE .....	10
FIGURE 16: TUNER CONTROLS DESCRIPTION .....	10
FIGURE 17: PANASONIC DV1500 .....	10
FIGURE 18: MONITOR MOUNTING .....	11
FIGURE 19: SCENIC VIEW CAMERA .....	11
FIGURE 20: HUBODOMETER .....	11
FIGURE 21: ENGINE .....	15
FIGURE 22: COLD STARTING AID .....	15
FIGURE 23; DESTINATION SIGN – ELECTRONIC .....	16
FIGURE 24: LAVATORY .....	16
FIGURE 25: VENTILATION FAN INSTALLATION .....	17
FIGURE 26: DOOR LOCK .....	18
FIGURE 27: F/W TANK SERVICE VALVES .....	18
FIGURE 28: FUNCTIONING OF LAVATORY .....	19
FIGURE 29: LIQUID SOAP DISPENSER .....	20
FIGURE 30: AIR HORN VALVE .....	22
FIGURE 31: HEADLIGHTS CLEANING SYSTEM .....	22
FIGURE 32: TUBING AND FITTINGS .....	23
FIGURE 33: WASHER NOZZLES ADJUSTMENT .....	23
FIGURE 34: MULTIFUNCTION LEVER .....	23
FIGURE 35: WINDSHIELD WASHER RESERVOIR .....	23
FIGURE 36: WINDSHIELD WIPER INSTALLATION .....	24
FIGURE 37: WINDSHIELD WIPER (MOTOR SIDE) .....	24
FIGURE 38: WINDSHIELD WIPER (DRIVER SIDE) .....	24
FIGURE 39: DRIVING MECHANISM (DRIVER SIDE) .....	25
FIGURE 40: DRIVING MECHANISM (MOTOR SIDE) .....	25
FIGURE 41: WIPER ARMS POSITIONING .....	26
FIGURE 42: FIRE EXTINGUISHER INSTALLATION .....	31
FIGURE 43: NOZZLE BRACKETS IDENTIFICATION AND INSTALLATION .....	31

### 1. AUDIO AND VIDEO SYSTEM DESCRIPTION

The rack mounted components are gathered on the audio-video panel which is located in the first driver's side overhead compartment (Fig. 1). In addition to the power amplifier, options for AM/FM stereo radio and satellite radio, CD changer, karaoke, wireless microphone, DVD and videocassette player, scenic view and back-up camera system and GPS Navigation System module may be featured.

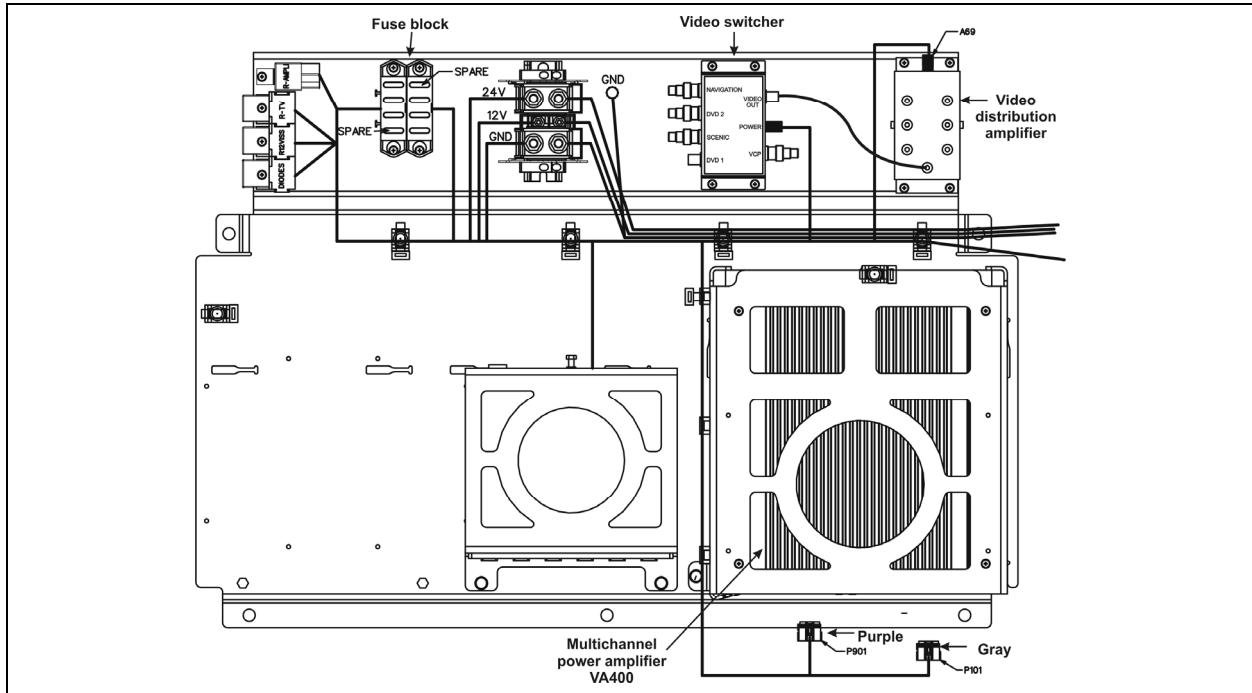

FIGURE 1 : AUDIO-VIDEO PANEL

Each service module mounted to the underside of the parcel racks contains a 40-watt speaker. The speakers in the passenger section are wired in stereo and are powered by the amplifier. A microphone outlet mounted in the driver's area is provided as standard equipment.

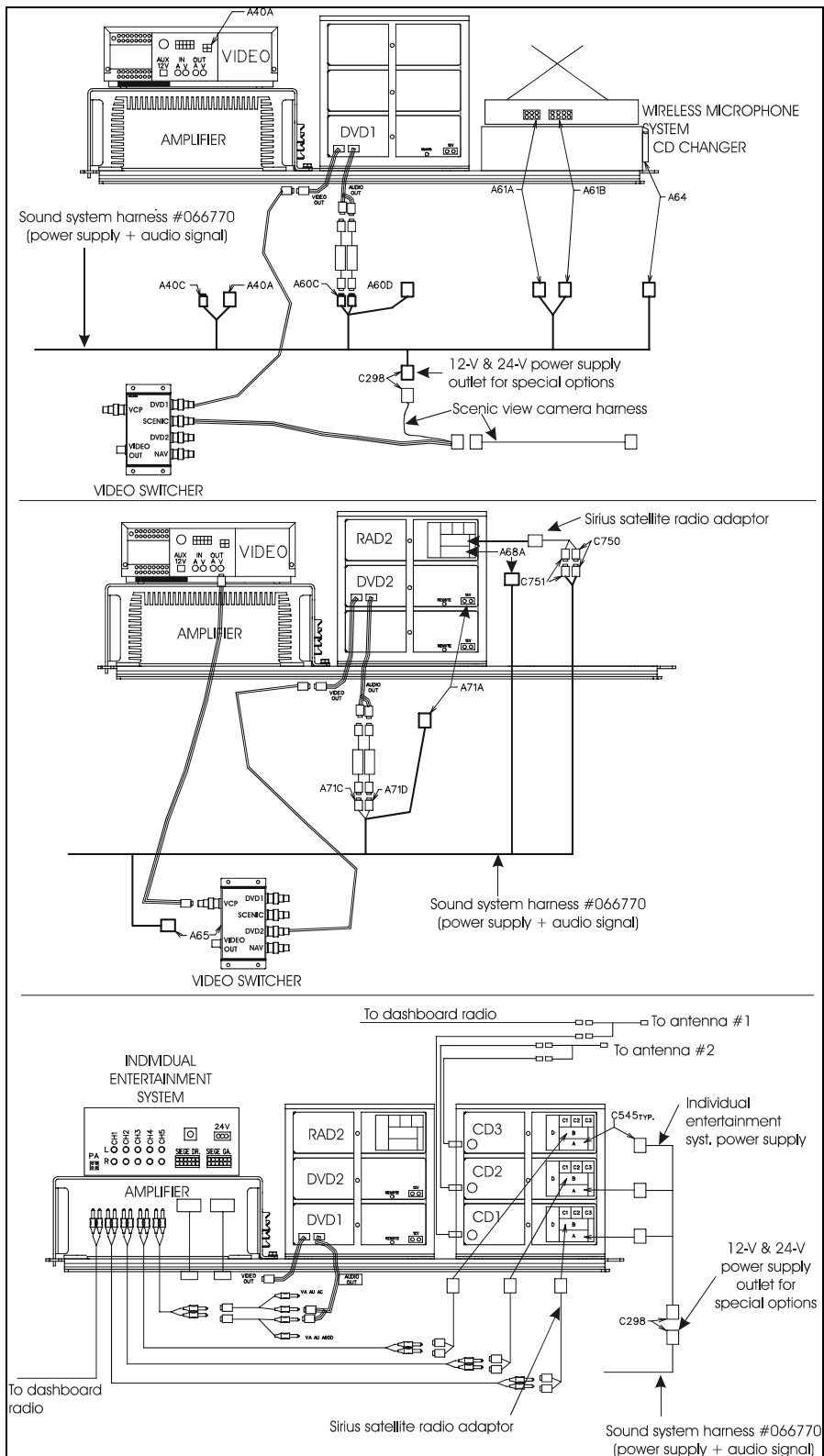

FIGURE 2: AUDIO & VIDEO CONNECTIONS

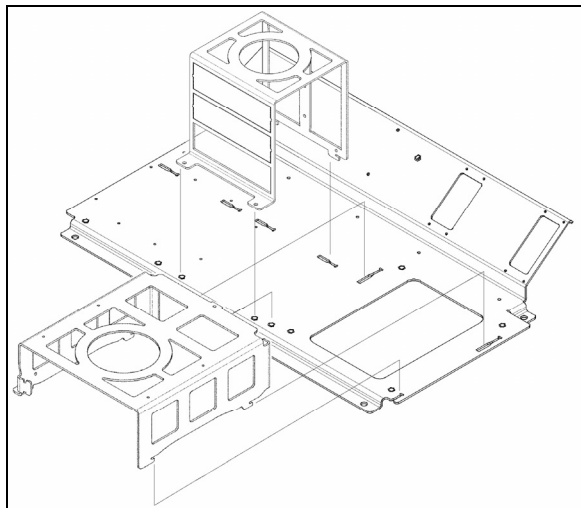

FIGURE 3: RACKS ON AUDIO-VIDEO PANEL 23059

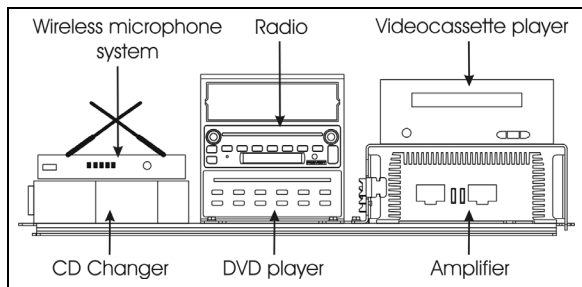

FIGURE 4: AUDIO-VIDEO PANEL

### 1.1 AM/FM RADIO

#### 1.1.1 VR300 AM/FM Radio / CD Player

This AM/FM/WX (weather band) radio CD player model has external CD changer capability (Fig. 4).

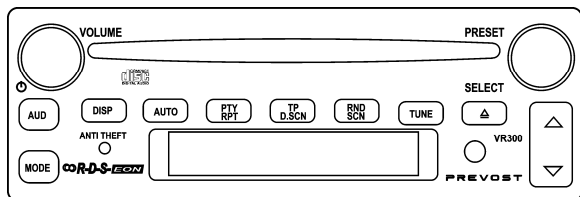

FIGURE 5: VR300 CD/AM/FM STEREO RECEIVER 23351

**NOTE**

*Before attempting to solve an electrical problem on the sound system, refer to the wiring diagrams.*

“VR300 Operating Instruction” manual is included at the end of this section. The radio is a serviceable component and should only be serviced by a qualified electronics technician.

Features:

- CD changer control
- Anti-theft
- Auto preset memory
- LED illumination
- Liquid crystal display
- Amber illumination
- Panel light dimming
- Quartz clock
- Mute function
- Search & repeat
- Track scan
- AUX input
- 4x20W power
- 4 low level outputs

#### 1.1.2 Security Code

Your radio is protected by a security code. The security code can be found on a label delivered with the radio. The security code cannot be changed.

When the radio power is first turned on after power has been interrupted, “ID CHECK” and then “LOCK” is displayed for 3 seconds. Then “0000” is displayed.

To unlock the radio, enter the four-digit security code found on the removable label (refer to “VR300 Operating Instruction” manual).

If the code is entered correctly, the radio will switch to the last active mode (i.e. FM, CD, etc.) and is ready to use. If the code is entered incorrectly, you can try 2 more times. After 3 incorrect entries, the radio will display “LOCK.” You must turn the radio off, while leaving the ignition and battery on, for 1 continuous hour before attempting to unlock the radio again.

#### 1.1.3 Removal

To remove the radio from its location, proceed as follows:

1. Place the ignition switch in the “OFF” position.
2. Remove the dashboard panel cover.
3. Disconnect the electrical cable connectors from radio and unfasten back plate securing nut.
4. To separate the radio from its support, insert the U shaped tool in the two pairs of holes found each side of the radio front panel.
5. Push the unit through the front dashboard panel.
6. Install a new unit by reversing the procedure.

**NOTE**

Remember that because power has been interrupted during removal, the radio must be unlocked by entering the four-digit security code after reinstallation.

### 1.1.4 DELPHI Premium Satellite Radio AM/FM/MP3 CD stereo (OPTIONAL)

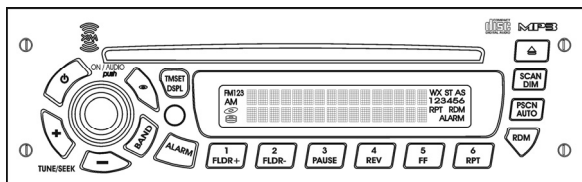

FIGURE 6: DELPHI PREMIUM SATELLITE RADIO 23355

This XM or SIRIUS satellite radio receiver can be located on the dashboard, replacing the standard radio or inside the first driver's side overhead compartment, where many radio can be installed.

#### Features:

- Satellite radio ready with weather band
- 7-channel weather band
- 18 FM & 6 AM presets
- Steering wheel control compatible
- Anti-theft
- Auto preset solutions
- MP3 playback capability
- LED illumination
- Liquid crystal display
- Quartz clock
- Single disc
- Random & repeat play modes
- SDARS receiver compatible
- AUX inputs
- 4x17W power

The complete operating instruction manual is included in your vehicle's *technical publications box*.

## 1.2 VSS-04 SOUND SELECTOR

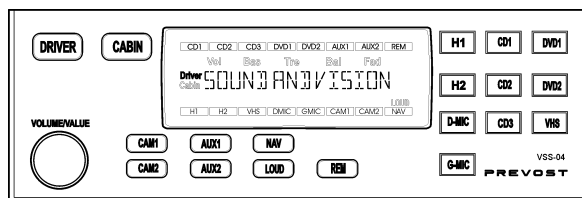

FIGURE 7: VSS-04 SOUND SELECTOR 23350

The VSS-04 Sound Selector enables the driver to select different audio or audio-video entertainment sources for the driver area and the passengers' area. The driver may be listening to the radio and watching the Navigation System route information on the monitor while the passengers may be watching a movie from the DVD player.

With this unit, you can adjust each audio source sound settings (e.g. volume, bass, treble, balance, fade).

#### Features:

##### 7 audio sources

- Radios (2)
- Microphones (2)
- CD players (3)

##### 5 audio-video sources

- DVD players (2)
- VCR (1)
- Auxiliary (2)

##### 3 video sources

- cameras (2)
- GPS Navigation system (1)

### 1.2.1 Removal

To remove the Sound Selector from its location, proceed as follows:

1. Place the battery master switch in the "OFF" position.
2. Remove the dashboard panel cover.
3. Disconnect the electrical cable connectors from unit and unfasten back plate securing nut/screw.
4. To separate the Sound Selector from its support, insert a flat screwdriver each side of the unit front panel.
5. Push the unit through the front dashboard panel.
6. Install a new unit by reversing the procedure.

The operating instructions are included in your Operator's Manual.

## Section 23: ACCESSORIES

### 1.3 VD-404 MOBILE DVD PLAYER



FIGURE 8: VD-404 MOBILE DVD PLAYER

The MOBILE DVD PLAYER is located in the first parcel compartment on the driver's side. Instructions for proper use of this unit are included at the end of this section.

Features:

- **POWER**  
Operating voltage: 12-volt DC
- **COMPATIBILITY**  
This DVD player can play the following disc formats:  
DVD, CD, VCD, DVCD, MP3, CD-R, CD-RW
- **SYSTEM FUNCTIONS**  
Video output system: system MULTI, NTSC or PAL switchable.
  - 1 L/R audio output
  - 1 L/R audio input
  - 1 AUX video output
  - 1 rear camera video input
  - 3 video outputs with one dedicated self switching rear view monitor
- **ADDITIONAL VIDEO FEATURES**  
Multi-angle, multi-view, multi-audio function, multi-level forward and backward motion, play position memory, resume stop and repeat function.

### 1.4 MULTICHANNEL POWER AMPLIFIER VA400.8

This 400-watt, 6-channels brings an added dimension to your stereo equipment and increases the total output of the system.

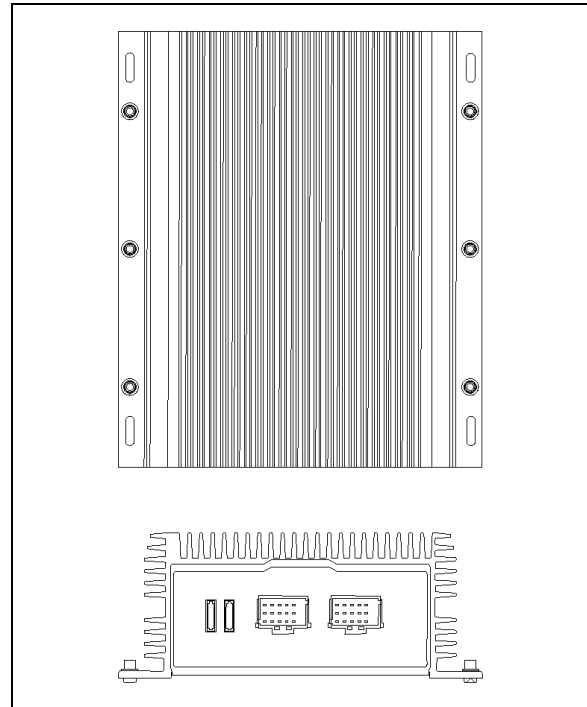

FIGURE 9: MULTICHANNEL POWER AMPLIFIER

For optimum sound quality, adjust the subwoofer crossover filter as shown on figure 10. This adjustment is necessary to balance the subwoofers volume in respect to the other speakers and also to cut high frequencies for a better sound quality.

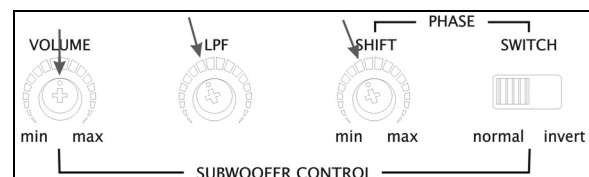

FIGURE 10: CROSSOVER ADJUSTMENT

### 1.5 SPEAKERS

Each passenger's overhead console mounted to the underside of the parcel racks contains a 20-watt Dual Cone 10cm speaker. The speakers in the passenger's section, wired in stereo and arranged in a delta configuration are powered by the amplifier.





FIGURE 11: 10cm DUAL CONE SPEAKER

The vehicle may be equipped with two additional Hi-Fi speakers in the driver's area, mounted one on each side. This arrangement provides the driver with clear stereo sound. Controls for the driver's audio allow selection between the radio and the auxiliary audio (independent of the passenger's speakers) or muting the speakers.

Two specially designed subwoofers may be fixed as an option under a passenger seat with anti-vibration supports.

## 1.6 VIDEO CASSETTE PLAYER (VCP)

The optional VCP is located on the audio-video panel in the first overhead compartment. Instructions for proper use of the VCP are provided in the technical publication box.



FIGURE 12: V3000 VIDEO CASSETTE PLAYER

### 1.6.1 Removal

1. Place the ignition switch in the "OFF" position.
2. Remove the VCP/VCR mounting locknuts from rubber mounts.
3. Disconnect wiring.
4. Remove VCP/VCR unit from parcel compartment.

### 1.6.2 Installation

1. Install VCP/VCR unit into parcel compartment aligning rubber mount studs with mounting holes. Insert mount studs through mounting holes.
2. Install locknuts on mount studs.
3. Reconnect wiring.
5. Place the battery master switch in the "ON" position.

## 1.7 BOOM-TYPE MICROPHONE

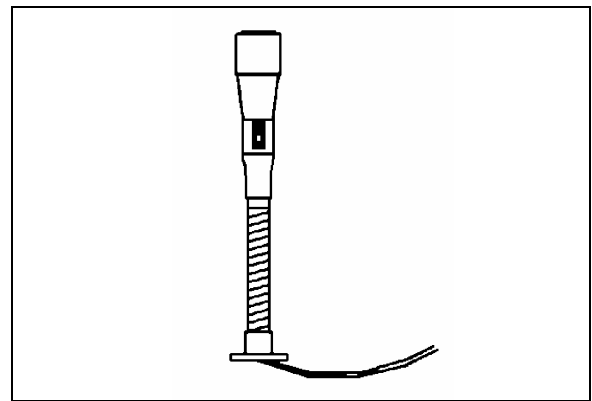

FIGURE 13: BOOM-TYPE MICROPHONE

23083

### 1.7.1 Removal

1. Place the ignition switch in the "OFF" position.
2. Remove the mounting screws at mounting flange.
3. Disconnect wiring.

### 1.7.2 Installation

1. Reconnect wiring.
2. Align mounting flange with holes and install screws.
3. Remove spacer block mounting screws.
4. Insert spacer block and install mounting screws.
5. Place the battery master switch in the "ON" position.

1.8 HANDHELD PRIORITY MICROPHONE

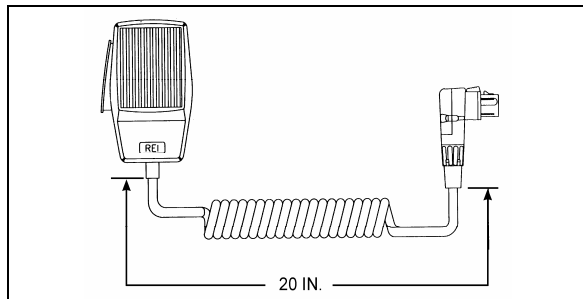

FIGURE 14: HANDHELD PRIORITY MICROPHONE 23216

1.9 WIRELESS MICROPHONE

The system 2000 16 channel wireless microphone, Receiver and Charging Cradle are custom designed units that allow for wireless PA communication from anywhere on the coach. The unit consists of a receiver mounted in the parcel area directly behind the driver, and a rechargeable hand-held microphone and charging unit. Instructions for proper use of the microphone are included in the "REI Operating Manual" which is provided in the technical publications box delivered with the vehicle.

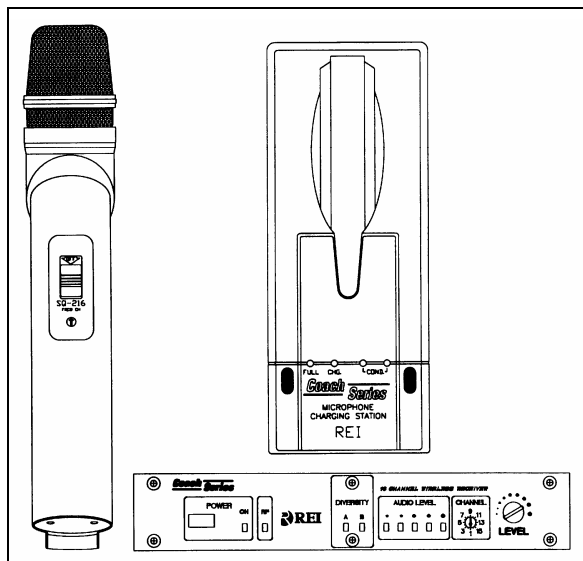

FIGURE 15: WIRELESS MICROPHONE

1.10 TV TUNER

For TV tuner control descriptions, refer to fig. 16.

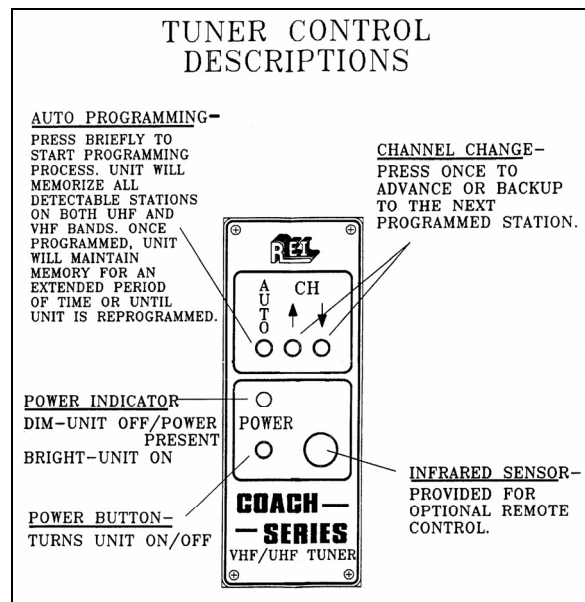

FIGURE 16: TUNER CONTROLS DESCRIPTION

1.11 KARAOKE

The modified Panasonic DVD Player powers up automatically when the video system is activated. The unit can be controlled with the plug-in remote control, or the control head, which has access to the PLAY and STOP commands.

If so equipped, instructions for proper use of the Karaoke system are included in the "Operating Manual" that is provided in the technical publications box delivered with the vehicle.

1.11.1 Karaoke Panasonic Sound System – MOBILE DVD PLAYER DV1500

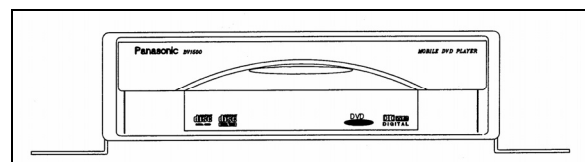

FIGURE 17: PANASONIC DV1500

1.12 DRIVER'S SPEAKERS

The driver's speakers are mounted one on each side. This arrangement provides the driver with clear stereo sound. Controls for the driver's audio allow selection between the radio and the auxiliary audio (independent of the passenger's speakers) or muting the speakers.

1.13 MONITOR

1. Place the ignition switch in the "OFF" position.
2. Unfasten the retaining screw located on the monitor R.H. side.
3. Slide the monitor to the right to release it from the mounting bracket.

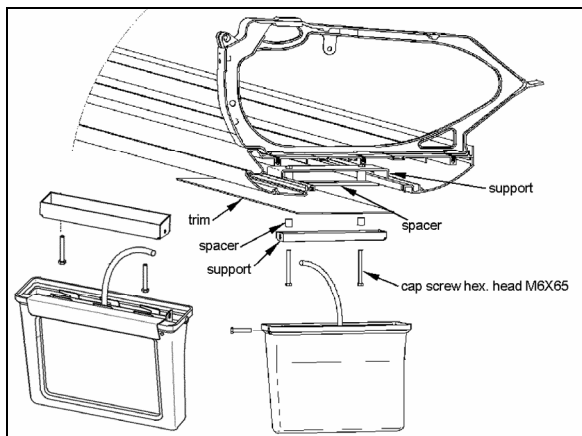

FIGURE 18: MONITOR MOUNTING 23221

1.14 SCENIC VIEWING SYSTEM

The scenic viewing system enables the passengers to view the road ahead of the vehicle. This system is composed of a camera, a dashboard mounted ON/OFF switch and the video switcher located on the audio-video panel (Figs. 1 & 19).



FIGURE 19: SCENIC VIEW CAMERA

1.15 ROOF ANTENNA INSTALLATION

1. Find the desire location and drill a hole according to specification.
2. To remove dirt and grease, wash hole edge with alcohol.

3. If so equipped, remove foam padding ring from antenna to free the metal surface (foam can produce air bulbs in new rubber seal).
4. With SIKA 205, wash the opening edge and the antenna base surface, wait at least two (2) minutes for chemical evaporation.
5. Apply new seal SIKA 221 on both, vehicle hole edge and antenna base.
6. Fix the antenna in place.
7. Remove excess seal and complete a finishing joint all around the antenna base.

2. HUBODOMETER

2.1 DESCRIPTION

An optional wheel hubodometer (Fig. 20) may have been installed on the R.H. side of the drive axle. It indicates the total distance in miles or kilometers covered by the coach since it has left the factory, including road testing.

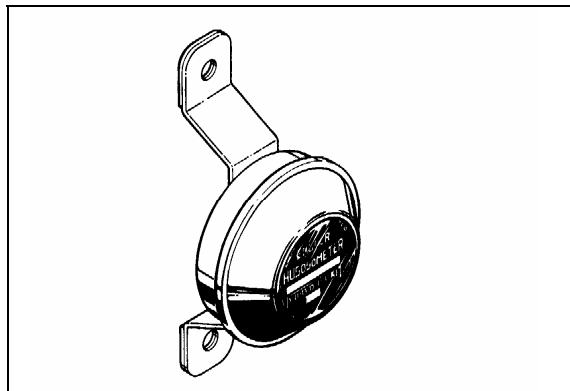

FIGURE 20: HUBODOMETER 23024

2.2 OPERATION

The hubodometer is calibrated for a specific wheel size (diameter). Wheel rotation causes a mechanism inside the hubodometer to record distance after a predetermined number of rotations. The unit should be serviced at a competent speedometer repair facility.

**NOTE**  
 Do not use paint, solvent or thinner on hubodometer face or on plastic hubcaps. Do not weld on hubodometer.

**2.3 REMOVAL**

To remove the unit, remove the two lock nuts and washers securing it to the wheel hub, and pull the unit off the studs.

**2.4 INSTALLATION**

Place the hubodometer unit over the wheel hub studs. Replace the lock washers and nuts. Torque stud nuts to 110-165 Lbf-ft.(150-225 Nm).

**3. BACK-UP CAMERA AND MONITOR**

An optional back-up camera is available which provides the driver with visual assistance when backing-up. The camera is automatically activated when the transmission is put in reverse gear and the ignition switch is "ON".

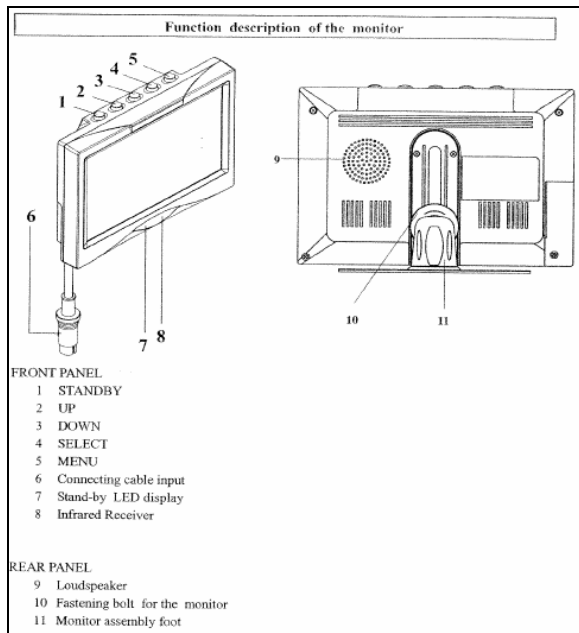

**BUTTON DESCRIPTION**

**1) STANDBY** On/Off switch

**2) UP** This key has 3 functions

- Increase of the volume during normal operation;
- Modification of the setting within a function e.g. contrast (after calling up the menu);
- By pressing this key when putting in the reverse gear, the distance markings move upwards;

**3) DOWN** This key has 3 functions

- Decrease of the volume during normal operation;
- Modification of the setting within a function e.g. contrast (after calling up the menu);
- By pressing this key when putting in the reverse gear, the distance markings move downwards;

**4) SELECT** This key has 3 functions

- Selection of the video sources (CA1 → CA2 → AV → CA1). Press less than 1.5 seconds;
- Selection of the functions e.g. picture setting (after calling up the menu);
- Deleting and calling OSD letters of title & time (press longer than 1.5 seconds) during normal operation;

**5) MENU** This key has 2 functions

- Activation of the dimmer function (press less than 1.5 seconds) during normal operation;
- Calling up the menu (press longer than 1.5 seconds, four menus can be called up). Press the key once again to call up the individual menus;
  - a) PICTURE= Functions for the image setting;
  - b) USER= Selection of the system function;
  - c) TIME= Setting time and date;
  - d) INSTALL= Setting the camera function (e.g. mirror function);

**6) BUSH FOR THE MONITOR CABLE OF THE CONNECTION BOX**

**7) STANDBY DISPLAY**

**8) INFRARED RECEIVER**

**MONITOR MENU DISPLAY**

The monitor (RV59 HD) is equipped with an On-Screen Display (OSD) function which displays date, camera, channel, mirror mode and distance markings. These functions can be selected on MENU. To calling up the menu, press longer than 1.5 seconds. Four menus can be called up. Press the key once again to call up the individual menus.

For calling up the menu PICTURE press the key **MENU** longer than 1.5 seconds. The menu PICTURE appears.

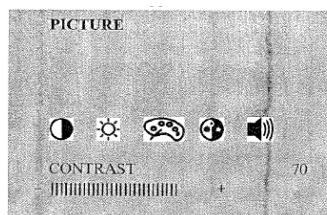

Graphic means the followings.

- CONTRAST
- BRIGHTNESS
- COLOR
- TINT
- VOLUME

Select the function (e.g. contrast) by pressing the key **SELECT** repeatedly. The setting within the function can be modified with the keys **UP** and **DOWN**.

For calling up the menu USER press the key **MENU** once again. The menu USER appears. Select the function (e.g. SELECTION) by pressing the key **SELECT** repeatedly as necessary. The setting within the function can be modified with the keys **UP** and **DOWN**.

**USER**  
 LANGUE ENG  
 SCREEN WIDE  
 TITLE ON  
 TIME ON

POSSIBLE SETTINGS:  
 LANGUAGE: ENGLISH/GERMAN (ENG/DEUT)  
 SCREEN NOR 4:3, picture format 4:3  
 FORMAT: WIDE, picture format 16:9 FULL, picture format 16:9 middle enlarge  
 TITLE: CAMERA TITLE DISPLAY ON/OFF  
 TIME: TIME DISPLAY ON/OFF

For calling up the menu TIME press the key **MENU** once again. The menu TIME appears. Select the function (e.g. DATE) by pressing the key **SELECT** repeatedly as necessary. The setting within the function can be modified with the keys **UP** and **DOWN**.

**TIME**  
 TIME 08:25  
 DATE MAY01  
 YEAR 2005

- Hour-Month adjustable by UP BUTTON  
 - Minute/Date adjustable by DOWN BUTTON  
 - Year adjustable by UP/DOWN BUTTON

For calling up the menu INSTALL press the key **MENU** once again. The menu TIME appears. Select the function (e.g. SELECTION) by pressing the key **SELECT** repeatedly as necessary. The setting within the function can be modified with the keys **UP** and **DOWN**.

**INSTALL**

REAR CAM1  
 CAM1 MIR  
 CAM2 NOR

POSSIBLE SETTINGS:

REAR: Selection of priority camera (CAM1 or CAM2) which is triggered by rear gear.

CAM1: Selection of real picture or mirrored picture for camera 1

CAM2: Selection of real picture or mirrored picture for camera 2

NOTE1 The distance mark will appear on the picture of camera which set as MIR (mirrored).

NOTE2 Engaging the reverse gear, only distance mark will appear on the mirrored camera picture without any OSD. At the moment, no keys are available except UP/DOWN key for moving distance bar.

**BACK-UP CAMERA MODULE (Power box)**

The connection line consists of 6 branch lines as below:

RED	Voltage supply 12-volt to 24-volt (max. 32-volt)
BLACK/BROWN	Earth cable
WHITE	Control wire for switching on the dimmer function (night operation)
YELLOW	Control wire for switching on the side camera. The connection is to be made at the INDICATOR
ORANGE	Control wire for switching on the reversing camera. The connection is to be made at the reversing light

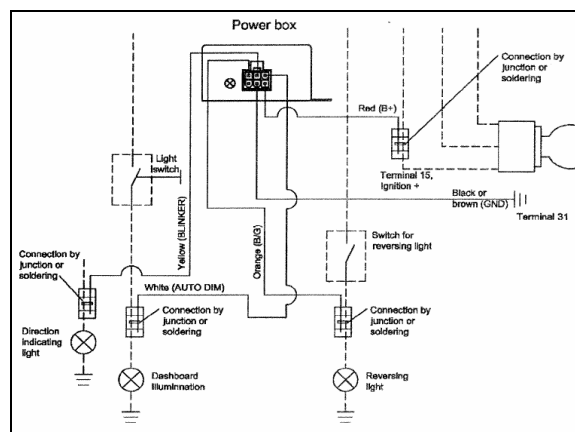

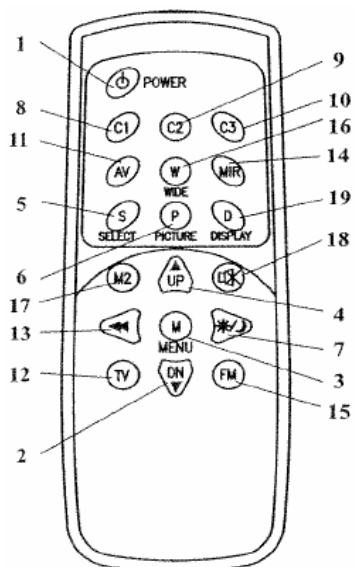

No	Key	Description
1	STANDBY	On/Off switch
2	DOWN ▼	This key has 3 functions. – Decrease of the volume during normal operation. – Modification of the setting within a function e. g. brightness (after calling up the menu). – By pressing this key when putting in the reverse gear the distance markings move downwards.
3	MENU	Calling up the menu on the screen. Three menus can be called up : a: PICTURE = Functions for the image setting b: USER = Selection of the system function c: TIME = Setting time and date d: INSTALL = Setting the camera function (e.g. mirror function)
4	UP ▲	This key has 3 functions. – Increase the volume during normal operation – Modification of the settings within a function e. g. contrast (after calling up the menu) – By pressing this key when putting in the reverse gear the distance markings move upwards.
5	SELECT	This key has 2 functions Selection of the video sources (CA1→CA2→AV) Selection of the functions e.g. picture setting (after calling up the menu)
6	PICTURER	Calls up the functions CONTRAST, BRIGHTNESS etc. directly for the picture setting. Carry out the setting with the key UP or DOWN.
7	DIMMER	Regulates the brightness to night operation temporarily
8	C1	Selection of the camera 1
9	C2	Selection of the camera 2
10	C3	Selection of the camera 3 (camera input 3 is not available))
11	AV	Selection of the video input (RCA)
12	TV	Not available
13	SEARCH	Not available
14	MIRROR	Reversing left and right of picture temporarily
15	FM	Not available
16	WIDE	Setting of the screen format NOR/NOR: 4:3, picture format 4:3 WIDE/WEIT, picture format 16:9 FULL/BREIT, picture format 16:9 middle enlarged
17	MONITOR2	Not available
18	MUTE	Switches off the tone temporarily
19	DISPLAY	This key has 2 functions – Deleting or calling OSD letters of Tile & Time temporarily – Leaving the menu

#### 4. COLD STARTING AID (ETHER)

The vehicle can be equipped with an electrically-operated type ether cold starting aid designed to ease engine starting when temperature is low.

On vehicles equipped with cold starting aid, the system consists of the main following parts:

- Ether starting aid switch
- Ether cylinder
- Solenoid valve (24 V)
- Thermal cutout valve
- Atomizer

The control rocker switch is located on the dashboard. This switch is provided with a locking mechanism to avoid accidental use when engine is running. To activate the ether starting aid, proceed as follows:

1. Prior to cranking engine, press down rocker switch for three seconds to fill solenoid valve.
2. Release switch to discharge shot.
3. Allow three seconds for shot to discharge.
4. Start engine, use additional shots if necessary to keep engine running.



#### CAUTION

This practice should be performed only when absolutely necessary. Excessive use of fluid could result in serious engine damage.

The ether cylinder and solenoid valve assembly are mounted on the engine compartment wall and are accessible from the engine compartment R.H. side door.

The thermal cutout valve is mounted on the engine (radiator side). Its function is to prevent discharge of ether when engine is warm (over 90°F (32°C)). The atomizer is installed on top of the air intake duct (Fig. 21).

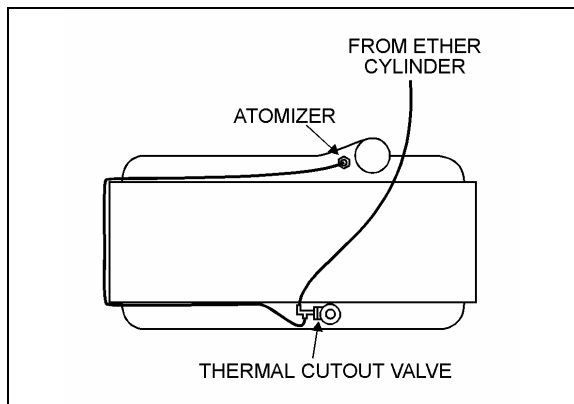

FIGURE 21: ENGINE 23032

4.1 PREVENTIVE MAINTENANCE

During the summer months, remove cylinder to avoid high temperature actuation of the cylinder safety relief device. Always screw valve cap into solenoid valve opening to prevent entrance of road dirt. When removing cylinder, be careful to prevent dirt from entering the valve.

4.2 TROUBLESHOOTING (IF SYSTEM IS NON-FUNCTIONING)

**! DANGER**

During the following test, direct free end of tube away from personnel and all sources of ignition as this fuel is extremely flammable. Avoid breathing vapors and contacting fuel with skin. Never smoke during test.

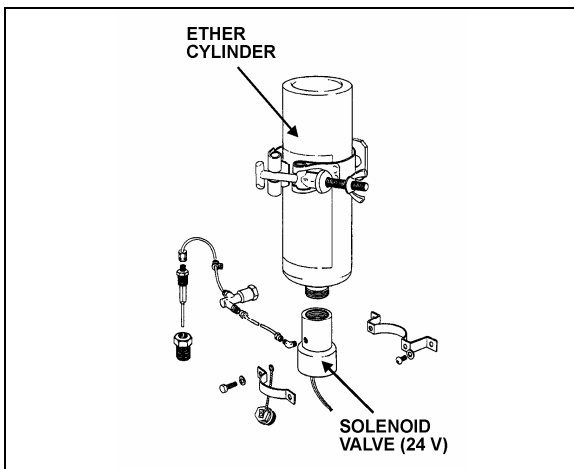

FIGURE 22: COLD STARTING AID 23048

1. Check cylinder for hand tightness and fuel supply (Fig. 22). Empty cylinder weight is approximately 17 oz (480 g); full cylinder weight is approximately 35 oz (990 g). If

cylinder is empty, replace it. Before replacing cylinder, install new valve gasket in solenoid valve.

2. If still not functioning, disconnect tubing at solenoid valve fitting. Actuate solenoid valve. (Ask an assistant to actuate solenoid valve using the rocker switch on the dashboard).
  - If solenoid valve is non-functioning, check electric circuit, (refer to wiring diagrams). If sound, remove and replace the solenoid valve. If not, repair electric circuit.
  - If valve is functioning, reassemble valve fitting and connect tube. Disconnect tube at thermal cutout valve from port "Tube from valve".
3. Actuate the solenoid valve.
  - If fuel is not discharged from tube, remove tube and blow out or replace.
  - If fuel is discharged, connect tube to thermal cutout valve, and disconnect other tube.
4. Actuate the solenoid valve.
  - If fuel is not discharged, replace the cut-out valve.

**NOTE**

*If engine coolant temperature is 90°F (32°C) or over, it is normal that fuel is not discharged as the valve is in closed position.*

- If fuel is discharged, connect tube to thermal cutout valve, and disconnect tube from atomizer.
5. Actuate the solenoid valve.
    - If fuel is not discharged from tube, fuel line is clogged. Remove tube and blow out or replace.
    - If fuel is discharged, replace the atomizer.

4.3 THERMAL CUTOUT VALVE QUICK TEST

1. Engine coolant temperature must be below 90°F (32°C).
2. Temporarily disconnect tube at thermal cutout valve from port "Tube to atomizer".

3. Actuate solenoid valve (Ask an assistant to actuate solenoid valve by means of the rocker switch on the dashboard). Fuel should be discharged through the thermal cutout valve.

**DANGER**

Avoid breathing vapors and contacting fuel with skin. Never smoke during test.

4. Reconnect tube to thermal cutout valve.
5. Start engine, using cold starting aid if necessary. Stop engine when it reaches operating temperature.
6. Disconnect tube at thermal cutout valve as in step 2, and repeat step 3. No fuel should be discharged.

## 5. DESTINATION SIGN

### 5.1 ELECTRONIC DESTINATION SIGN (OPTIONAL)

The destination sign is located at upper front of the vehicle. To change the destination, depress the selecting switches until the desired destination appears in the LCD display.

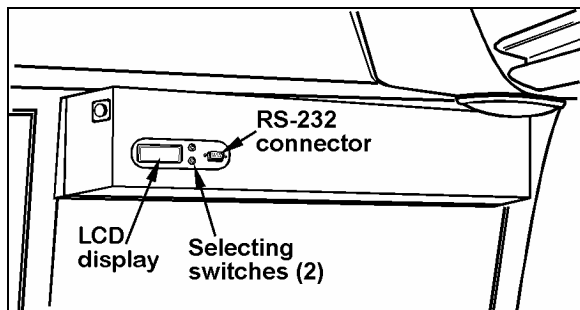

FIGURE 23; DESTINATION SIGN – ELECTRONIC 23123

**NOTE**

The destination sign must be programmed with a computer connected to the RS-232 connector prior to first use. Follow the instructions on the computer disk to install and run the software.

**NOTE**

The destination sign is equipped with lights (bulb light or fluorescent) which illuminates automatically when the headlight or fog light switch is activated.

## 6. LAVATORY

### 6.1 DESCRIPTION

The lavatory is located in the rear R.H. corner of the coach. It is equipped with a chemical flush toilet, bathroom tissue dispenser, washbasin, towel dispenser, waste container, mirror, ashtray, and a cleaning cabinet. A liquid soap dispenser and moist towel dispenser are optional.

Locking the lavatory door from the inside will illuminate a fluorescent light in the lavatory and two outside signs to indicate occupation. One sign is located on the outer wall of the lavatory and another sign is located over the windshield. An indicator light on the dashboard will illuminate to inform the driver when the lavatory is occupied. A night-light is permanently lit in the lavatory when the ignition switch is in the ON position.

If emergency assistance is required, the lavatory occupant can actuate a buzzer that will sound in driver's area. The buzzer's push-button (c/w instruction label) is located on the inner curbside wall of lavatory.

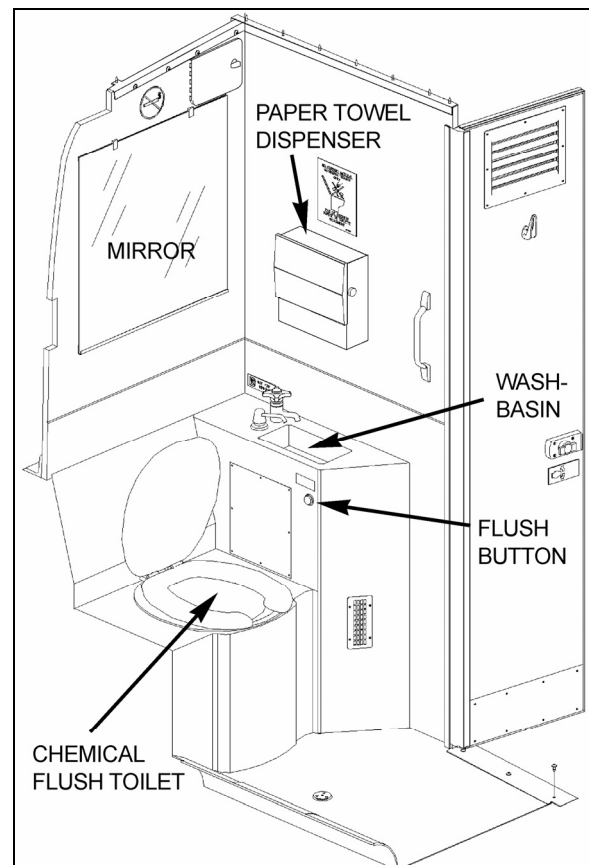

FIGURE 24: LAVATORY

23235



The lavatory has its own ventilation system that operates only when ignition switch is in the "ON" position. An auxiliary sump tank (Fig. 28) (optional) allows main tank to be drained by manually opening an interconnecting tank valve (5, Fig. 27). Lavatory can then be operated for longer periods until coach can be serviced at a facility equipped for disposal.

The fresh water tank, located behind compartment mirror (Fig. 28), is equipped with a thermal drain valve that will drain the tank when water temperature approaches the freezing point preventing damage to the tank (Fig. 28). The fresh water supplies water to the washbasin by gravity. Two tubes are connected on top of the tank. One serves as overflow as well as a vent tube and runs along the curbside wall to the engine compartment R.H. side (6, Fig. 27) while the other tube is connected to the fresh water fill connection which is also located in engine compartment R.H. side (1, Fig. 27). A third tube connected in the bottom of the fresh water tank allows fresh water to flow to the washbasin faucet. Water from washbasin drain tube flows to the main sump tank.

Also, a drain hole located on lavatory floor drain water splashed on the floor to the engine compartment R.H. side.

## 6.2 MAINTENANCE

The servicing procedure for the lavatory is described in the "Operator's Manual" included in the technical publications box delivered with the vehicle.

## 6.3 VENTILATION FAN

### 6.3.1 Description

The lavatory ventilation fan, mounted in engine compartment behind the oil reserve tank (Fig. 25), serves two purposes. It exhausts objectionable odors and provides a constant air circulation in the lavatory compartment by heating or cooling the lavatory with the vehicle ambient air. Air flows in the lavatory compartment through a vent grill located on the lavatory door and exhausts through a grill located next to the toilet.

#### **NOTE**

*This fan runs constantly when the ignition switch located on the dashboard is in the "ON" position.*

### 6.3.2 Maintenance

The frequency of preventive maintenance should be determined according to vehicle mileage and operating conditions. However, it is recommended to check this item every 50,000 miles (80 000 km) or once a year, whichever comes first.

Remove fan and motor assembly. Check for fan housing wheel and motor free operation. When defective motor occurs, new motor must be installed.

### 6.3.3 Removal and Installation

1. With the engine compartment rear doors opened, remove hose clamp securing duct to ventilation fan inlet, and disconnect duct.
2. Disconnect the ventilation motor wiring connector.
3. Remove the support bracket screw. Remove the three bolts fixing the ventilation fan housing support. Remove the ventilation fan assembly from its location.
4. The unit can now be disassembled and motor replaced.
5. Reverse previous steps to reinstall ventilation fan assembly on vehicle.

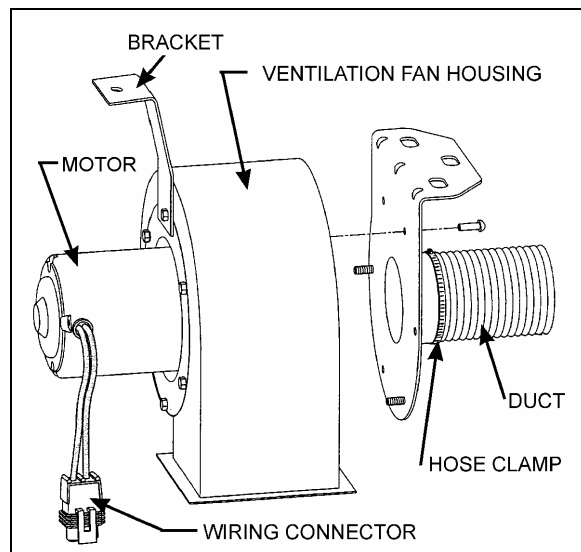

FIGURE 25: VENTILATION FAN INSTALLATION 23222

## 6.4 DOOR LOCK

Lavatory door lock has inside and outside handles, as well as an inside latch to lock door from inside the compartment. If the lock fails to release, the door can be opened from the outside using a special key which is supplied to

## Section 23: ACCESSORIES

the driver. Lock assembly can be removed from the door, then readily disassembled and parts replaced, if necessary (Fig. 26). A thin coat of lubricant on all moving parts will ensure trouble-free operation.

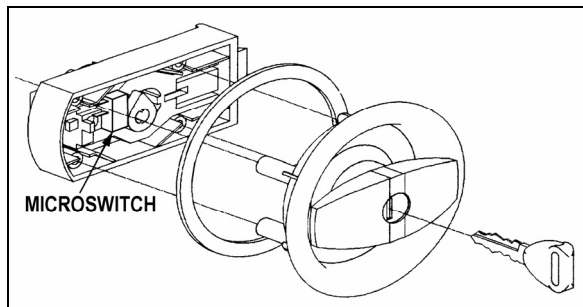

FIGURE 26: DOOR LOCK

23320

### 6.5 LAVATORY LIGHT

The lavatory light is installed on ceiling. A microswitch, which is mounted inside the latch housing, is activated by the door lock mechanism upon locking to energize the circuit. This switch is readily serviced by removing the four Phillips-head screws securing the housing to the door interior frame.

Proceed as Section 06, Electrical System, *Dome, Rear Roof and Lavatory Lights* for lights replacement.

### 6.6 LAVATORY NIGHT-LIGHT

The lavatory night-light is illuminated as soon as the ignition switch is set to the "ON" position. See Section 06, Electrical System, *Parcel Rack / Lavatory Night Light - "Bulb Removal and Replacement"* for lights replacement.

### 6.7 EMERGENCY BUZZER

The lavatory emergency buzzer is mounted on the inner curb side wall of lavatory and sounds when the emergency call push-button switch in the lavatory compartment is activated. For specific wiring information, refer to wiring diagrams. To remove the emergency call push-button switch, proceed as follows:

1. Remove both phillips-head screws retaining pushbutton switch plate to wall.
2. Remove steel plate located on L.H. side of pushbutton switch.
3. Remove switch through this opening, taking care to disconnect electric wires.

### 6.8 FRESH WATER TANK

One panel allows access to the fresh water tank.

It is located behind the toilet mirror. Remove the tank as follows:

1. Remove the mirror.
2. Remove the fresh water tank tubing, bolts, and different connectors.
3. Remove the tank from the wall.
4. Reverse previous steps to reinstall fresh water tank assembly on vehicle.

#### 6.8.1 Fresh Water Tank Draining

The fresh water tank can be drained by simply opening the fresh water drain cock (Fig. 27). Don't forget to close cock when draining is done.

#### **NOTE**

*The fresh water reservoir is equipped with a thermal valve which is set to open at about 35°F, thereby automatically draining the reservoir in near-freezing temperatures.*

Routine draining and filling of lavatory tanks should be performed by maintenance personnel only. If engine or heating failure occurs in extreme weather conditions, emergency draining of water tanks should be performed under the most suitable conditions and should at all times be supervised by driver.

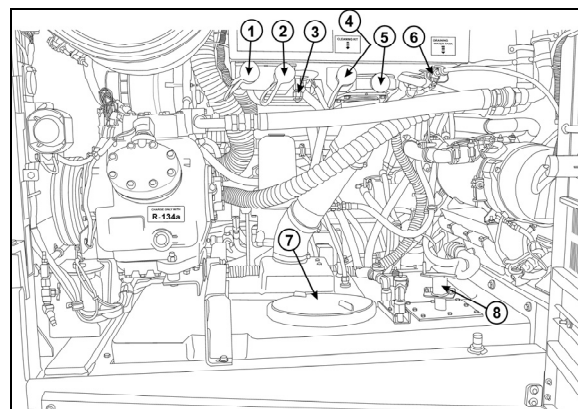

FIGURE 27: F/W TANK SERVICE VALVES

23378

- 1..... Fresh water tank fill connection
- 2..... Main sump tank fill connection
- 3..... Main sump tank overflow cock
- 4..... Cleaning kit hose connector
- 5..... Main sump tank drain valve
- 6..... Fresh water tank drain cock
- 7..... Auxiliary sump tank access cap
- 8..... Auxiliary sump tank drain valve

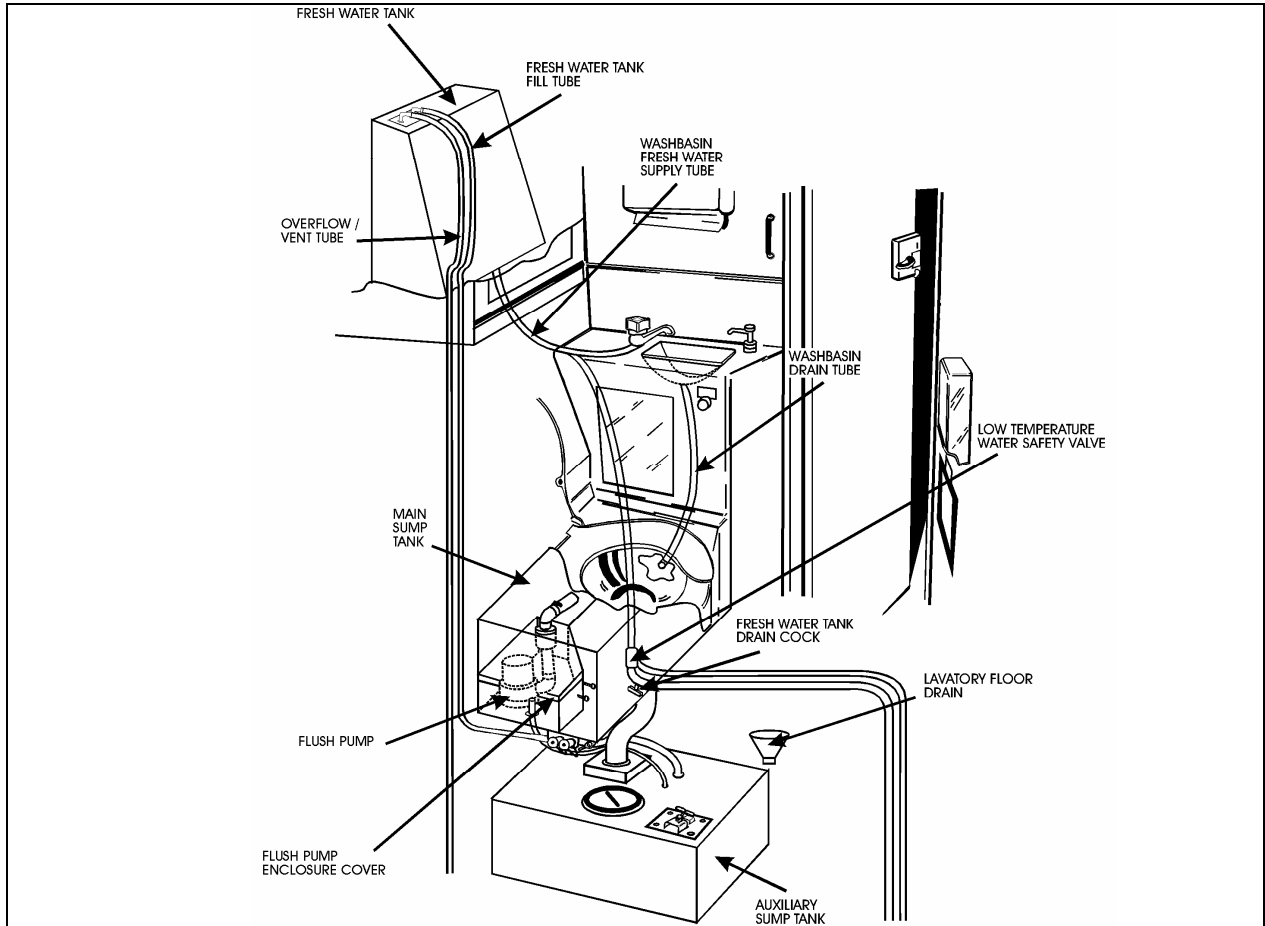

FIGURE 28: FUNCTIONING OF LAVATORY

23051

6.8.2 Fresh Water Tank Filling

Connect the fresh water supply hose to the fresh water reservoir fill connection (Fig. 27) located in the curb-side section of engine compartment. Fill the reservoir until the overflow tube leaks, signaling that the reservoir is full.

**DANGER**

Never put antifreeze in fresh water tank; antifreeze is toxic.

**WARNING**

If tank has not been drained for an extended period of time, draining and filling operations must be repeated three (3) times in order to clean tank and eliminate contaminated water.

6.9 LIQUID SOAP DISPENSER

A liquid soap dispenser may have been installed as optional equipment. To refill dispenser, proceed as follows:

1. Turn cover slightly clockwise until it stops.
2. Lift out piston and spout, cover and supply tube.

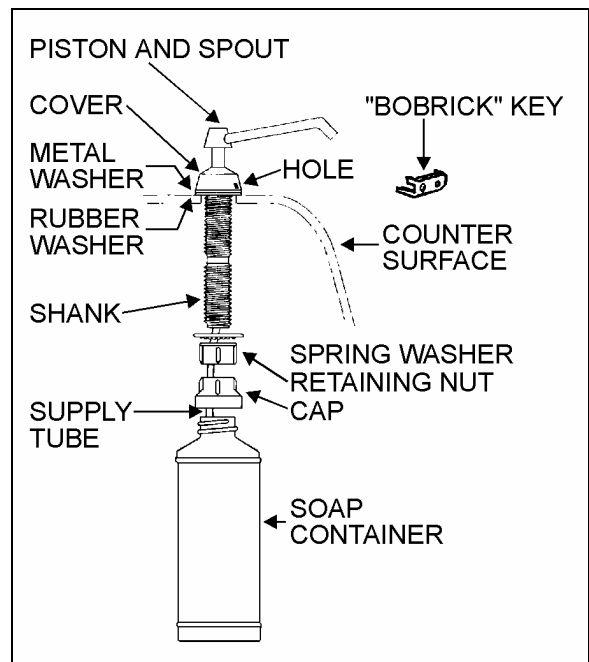

FIGURE 29: LIQUID SOAP DISPENSER 23039

3. Fill dispenser with soap. This model can dispense vegetable oil soaps, synthetic detergents, and lotion soaps.

**CAUTION**

Never use abrasive cleaners.

4. Replace supply tube, piston, and spout mechanism reversing the steps above.
5. Secure the cover by turning clockwise until lock snaps into position.

**NOTE**

The dispenser requires priming when extremely viscous lotion soaps are used. Remove piston and spout, cover and supply tube assembly. Pump water into assembly, then replace into dispenser.

6.10 FLUSH PUSH-BUTTON

The green flush push-button is located near the toilet. Press on push-button to actuate a pneumatic timer located on the other side of wall. This timer allows an electric current flow during a preset time to a pump into the sump tank.

6.10.1 Pneumatic Timer Removal and Installation

1. Unscrew and remove the flush push-button locking ring.
2. Remove steel plate located on L.H. side of pushbutton switch.
3. Remove pneumatic timer through this opening, taking care to disconnect electric wires.

**NOTE**

Care must be taken to avoid losing the spacers installed on the mounting sleeve.

4. Reverse the above procedure to reinstall timer. The recommended torque for the lock nut is 15 Lbf-ft (21 Nm).

6.10.2 Timer Adjustment

Timer can be adjusted from 0.2 second to 3 minutes by turning the time adjustment screw clockwise to increase time, and counterclockwise to decrease time. To gain access to the time adjustment screw, repeat steps 1, 2 and 3 in the previous paragraph "6.10.1 Pneumatic Timer Removal and Installation".

## 6.11 FLUSH PUMP

The submersible-type flush pump is mounted inside an enclosure in the sump tank (Fig. 28). The enclosure is provided with a screened side which, serves as a strainer to prevent solid matters from entering the pump.

The pump requires no periodic maintenance other than cleaning of the strainer side using a water jet introduced through the circular cap opening, once the sump tank is completely drained. The pump can run dry periodically without damage. However, for maximum seal life, the run dry periods should be kept to a minimum.

**CAUTION**

If vehicle is stored for an extended period of time, make sure to clean the strainer as solid matter will tend to pack, and will necessitate replacement of strainer.

## 6.11.1 Flush Pump Removal

1. Remove the toilet to gain access to the pump enclosure.
2. Remove the flush pump enclosure cover
3. Unsnap the flush pump.

## 6.12 SUMP TANKS

## 6.12.1 Main Sump Tank Draining

When recirculating water in the toilet is soiled, drain main sump tank. If equipped with the optional auxiliary sump tank, drain the main sump tank contents into the auxiliary tank and perform the filling procedure of the main tank.

## 6.12.2 Main Sump Tank Filling

Open the main sump tank overflow cock and connect a water supply hose to the toilet sump tank fill connection. The main tank is full when water starts flowing through the clear overflow tube. Close main sump tank overflow cock when the tank is full.

**CAUTION**

In cold weather, add 2 gallons (9 liters) of antifreeze (e.g.: ethylene glycol) in the toilet before filling main tank.

## 6.12.3 Auxiliary sump Tank Draining

Remove drain cap located under auxiliary sump tank then turn the auxiliary sump tank drain valve lever counterclockwise eight or nine times. Remove the access cap and flush tank with clean water. To close, turn the valve lever several times clockwise until the rubber bladder seals the drain hole. Reinstall access and drain caps.

**CAUTION**

Lavatory tanks should be serviced only at suitably equipped stations.

**NOTE**

*It is unlawful to dump sump tank contents in any location other than those designated as such.*

When a full draining is required, clean main tank by repeating the draining and filling operations while leaving the auxiliary sump tank drain cock opened. Close cocks and pour a pack of commercial toilet deodorant (Prévost part #900329) in toilet before adding the antifreeze and starting final filling of main tank.

**WARNING**

The toilet deodorant contains products that can be very irritating to skin. Use rubber gloves when handling and then clean toilet seat.

**WARNING**

Antifreeze must comply with the effective environmental act.

**CAUTION**

When cold weather is expected and there is no antifreeze in the tank, both sump tanks must be drained.

**NOTE**

*If there is no antifreeze solution in the tank, there is less risk of freezing if engine is operating due to the heat it produces.*

**NOTE**

*New coaches are delivered with the sump and fresh water tanks empty. Fill with water before putting the coach in service.*

## 7. AIR HORN VALVE

The air horn valve is located in the front service compartment and the air horn valve button is on the steering wheel center.

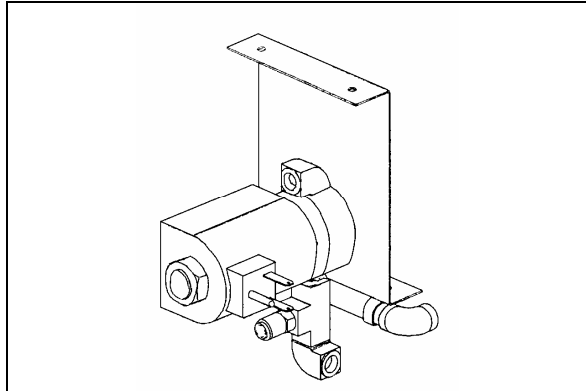

FIGURE 30: AIR HORN VALVE

23230

### 7.1 AIR HORN VALVE MAINTENANCE

When needed, the air horn valve can be serviced or replaced using the following procedure:

1. Unplug the cable connector;
2. Disconnect the air tubes;
3. Loosen the retaining bolts;
4. Service or replace the air horn valve;
5. Reinstall by reversing procedure.

## 8. HEADLIGHTS CLEANING SYSTEM

### 8.1 GENERAL DESCRIPTION

**NOTE**

*When inspecting the headlights cleaning system, check the washer fluid hoses, fittings and connectors to be sure they are properly connected and seal with no restriction to the flow of washer fluid. Check that the washer nozzles are properly aimed.*

The headlights cleaning system is independent from the windshield washer system and has its own washer fluid reservoir located in the front electrical and service compartment. However, this system shares the same telltale light than the windshield washer low level sensor (refer to Operator or Owner's manual for operation). Each pressing of this switch produces 2 successive 0.7 seconds jets.



## CAUTION

Do not operate the headlights washer while the washer fluid reservoir is empty. This may damage the washer fluid pump.

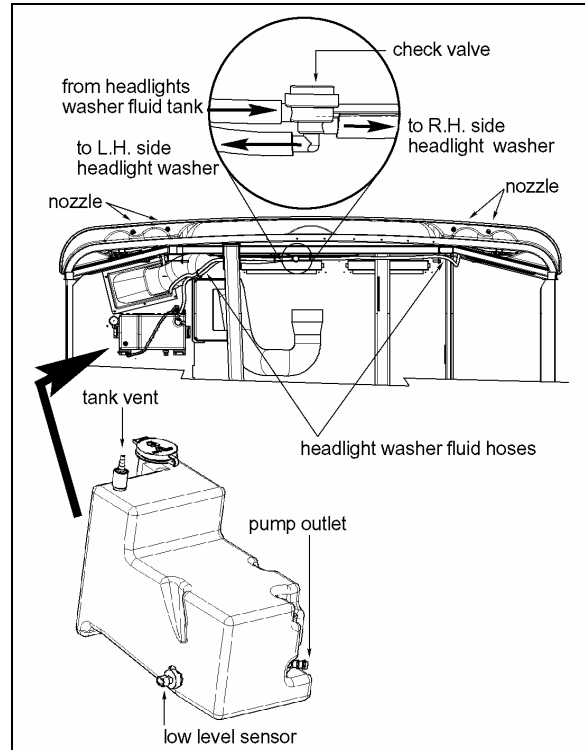

FIGURE 31: HEADLIGHTS CLEANING SYSTEM

23380

### 8.2 WASHER FLUID REFILLING

Open the filler neck cap and add regular windshield washer fluid as required. The tank has a capacity of 10 liters (2.6 US gallons). You may use water or windshield washer fluid as well but, during cold weather days, use windshield washer fluid suitable for freezing temperature only.

### 8.3 WASHER NOZZLES ADJUSTMENT

To avoid waste of washer fluid, assure the fluid jets are properly aimed. Adjust nozzles so they aim as described in figure 33. Align the jet adjustment tool #800377 with the reference line shown on the front view detail. As seen on the side view, position the end of the adjustment tool to a distance of ½" (high beam) and 1" (low beam) from the top of the headlight for proper aiming.



**CAUTION**

Because they are made of plastic, firmly tighten nozzle and bulkhead fittings by hand only.

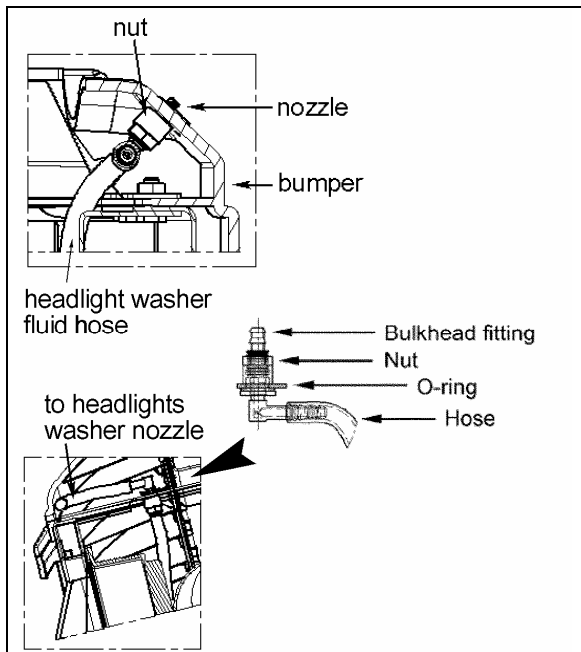

FIGURE 32: TUBING AND FITTINGS

23381

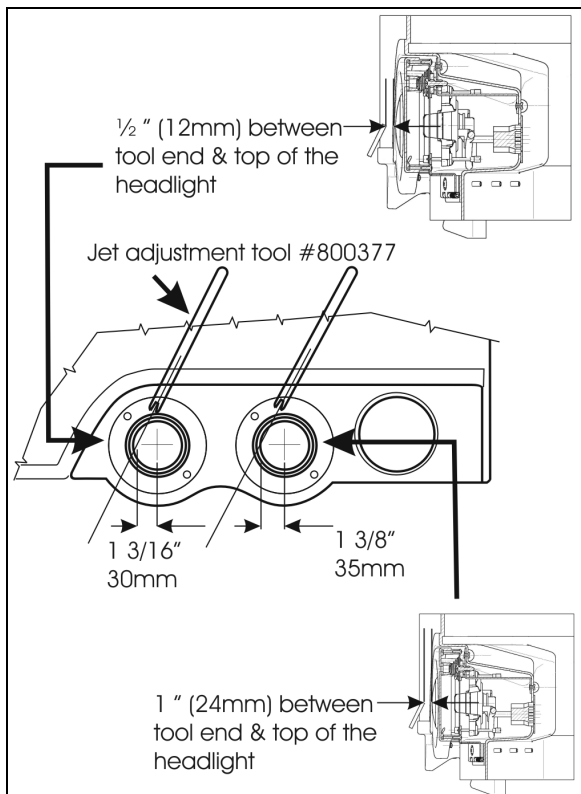

FIGURE 33: WASHER NOZZLES ADJUSTMENT

23382

**9. WINDSHIELD WIPERS AND WASHERS**

**9.1 GENERAL DESCRIPTION**

**NOTE**

When installing a wiper motor, arm or blade, follow recommended procedures to prevent misalignment, binding or malfunction. Check the windshield washer liquid hoses, fittings and connectors to be sure they are properly connected and seal with no restriction to the flow of washer liquid. Check that wiper arms have the proper sweep position and the washer nozzles are aimed so that spray is within the proper wiper pattern.

The windshield wipers are controlled by one electric wiper motor that is accessible for maintenance after removing the appropriate access panel beside the footwell (refer to figure 36). Turn the multifunction lever forward to activate windshield wipers (item 2, fig. 34). The first position operates the wipers at low speed and the second position operates the wipers at high speed. Turning the lever backwards will operate the wipers in the intermittent mode.

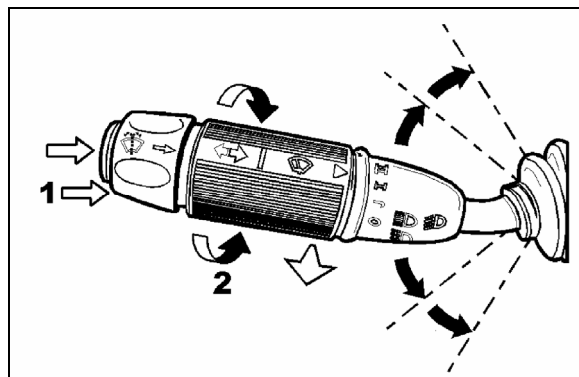

FIGURE 34: MULTIFUNCTION LEVER

23133

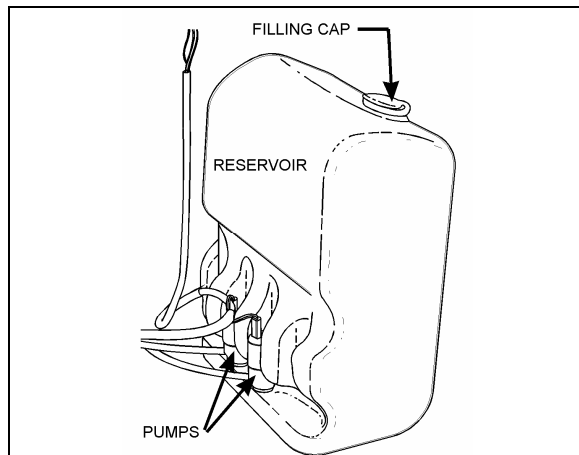

FIGURE 35: WINDSHIELD WASHER RESERVOIR

23220

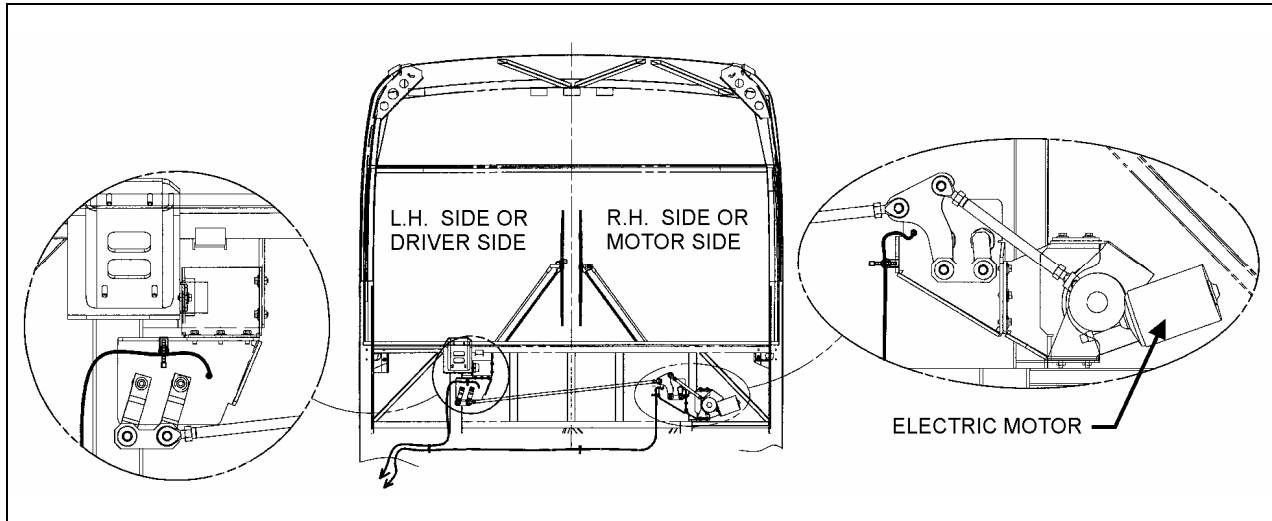

FIGURE 36: WINDSHIELD WIPER INSTALLATION

23287

The windshield washer pumps are electrically operated and are controlled by a washer control ring on the multifunction lever (item 1, fig. 34).

The windshield washer reservoir is located in the front service compartment (Fig. 35). This unit pumps the washer liquid to the spray nozzles where it is dispersed across the windshield.

## 9.2 WIPER ARM

Check operation of the wipers for proper blade sweep and angle.



### CAUTION

Do not attempt to manually move the wiper arms to make wiper blade sweep adjustments as damage to the wiper linkage or motor may occur. If it is necessary to adjust the sweep of blades, remove the arms and make adjustment by positioning the arms using serration on the wiper arm pivot shafts.

### 9.2.1 Wiper Arms Positioning

1. Reinstall the wiper arms and position as shown in figure 41. Before positioning the wipers at their final position, tighten the nuts to 9 Ft-lbs (12 Nm) at first.
2. To find the final position of the wiper arms, lift then release the wiper arm so it falls back on the windshield

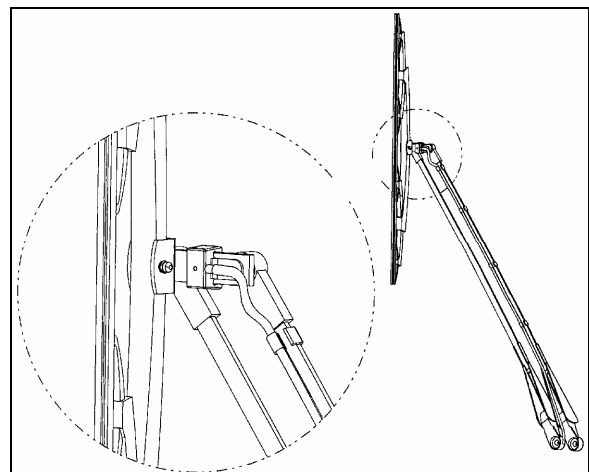

FIGURE 37: WINDSHIELD WIPER (MOTOR SIDE)

23329

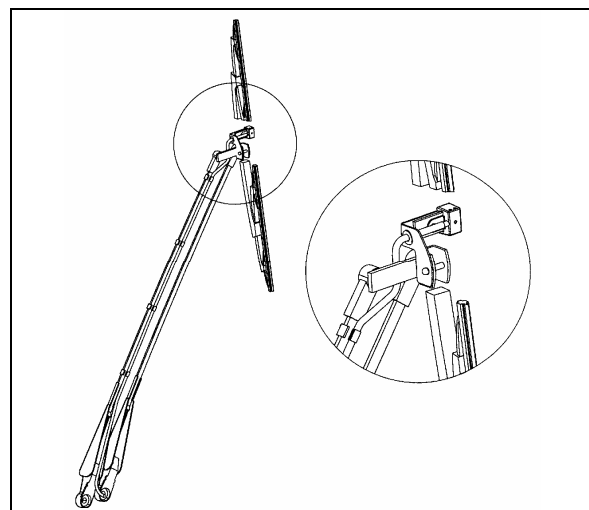

FIGURE 38: WINDSHIELD WIPER (DRIVER SIDE)

23328



3. When the final position is found, tighten the wiper arm nuts to 22 Ft-lbs (30 Nm). Wait 30 minutes and tighten again to 22 Ft-lbs.

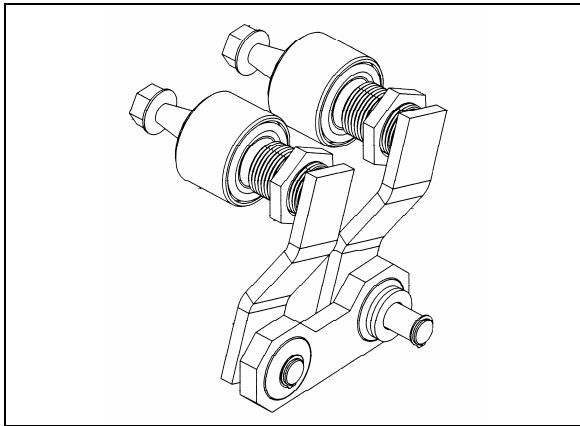

FIGURE 39: DRIVING MECHANISM (DRIVER SIDE) 23284

1. Remove the Phillips-head screws retaining the defroster panels, and remove panels.
2. Disconnect wiring connector from the windshield wiper motor.
3. Loosen clamping screw retaining the lever at the end of the motor driving shaft.
4. Remove the three bolts holding the motor to the steel plate.
5. Remove the windshield wiper motor (Prévost #800328), reverse removal procedure to reinstall.

4. Lower the protective cover.
5. Connect the windshield washer tubing at the base of the wiper arm.
6. Check the adjustment on a wet windshield.

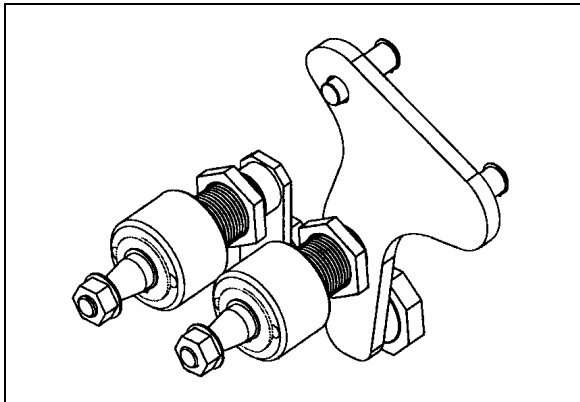

FIGURE 40: DRIVING MECHANISM (MOTOR SIDE) 23285

### 9.3 WINDSHIELD WIPER MOTOR

#### 9.3.1 Windshield Wiper Motor Replacement

The windshield wiper motor is located at lower front of the vehicle, behind the defroster panel. Refer to figure 34 for motor location.



#### **WARNING**

Park vehicle safely, apply parking brake, stop engine and set battery master switch to the "OFF" position prior to working on the vehicle.

**Section 23: ACCESSORIES**

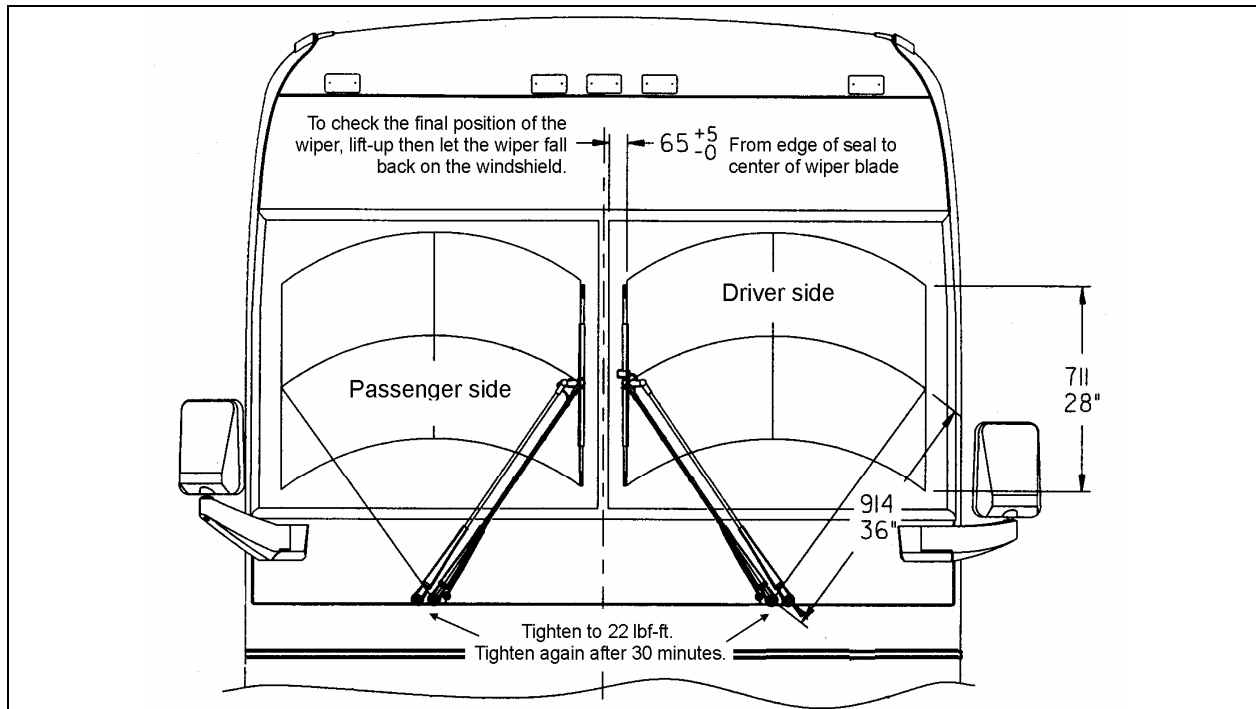

**FIGURE 41: WIPER ARMS POSITIONING**

23253

**9.4 TROUBLESHOOTING**







SYMPTOM	PROBABLE CAUSE	REMEDY
FAIL TO SPRAY WASHER FLUID	A. Reservoir empty. B. If below 32°F (0°C), improper washer fluid frozen. C. Contamination in tubing or nozzles. D. Tubing damage. E. Tubing bent (kinked) or off one or more connections.	A. Add proper fluid. B. Store coach or parts in heated area, then purge system with low-temperature solution. C. Remove with compressed air, if severely clogged, replace items. D. Replace section. E. Realign tubing and/or refit. Trim end to ensure proper fit or replace.
INADEQUATE SPRAYING	A. Tubing failure.	A. Replace tubing.
SLOW OPERATION	A. Improper solution. B. Jet stream improperly directed. C. Check if valve is stuck in the open position.	A. Replace with proper type solution. B. Reposition nozzles. C. Remove, clean or replace.

**10. TIRE PRESSURE MONITORING SYSTEM (TPMS)**

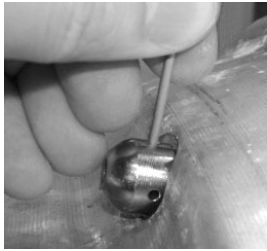

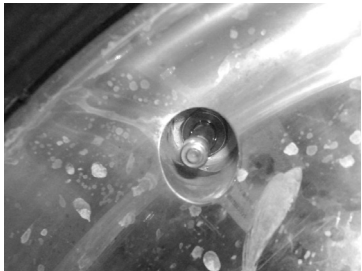
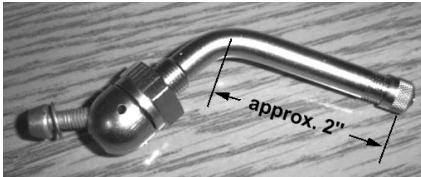

The optional active tire pressure and temperature monitoring system is a sensing device designed to identify and display tire operating data and activate an alert or warning when pressure or temperature irregularities are detected.

For more information on the operation and troubleshooting of the system, refer to the Operator’s Manual, chapters “Controls and Instruments”, “Safety Features and Equipment” and also “Appendix G”.

**10.1 TIRE VALVE INSTALLATION**

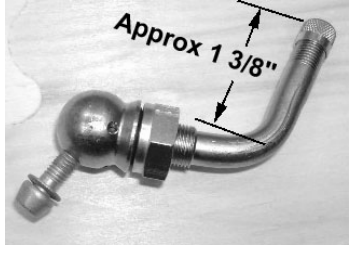

<p><b>Use as required a small rod to hold the valve in place when tightening.</b></p>			
<p><b>Steel Wheels</b></p>	<p><b><u>All wheels</u></b>                  a) Install Beru valve                  Torque valve to 44.5lb-in +/- 9.5                  b) no extension piece</p>	 <p>#Prevost 681083</p>	
<p><b>Aluminum Wheels (new CPM wheels)</b></p>	<p><b><u>Front axle and tag axle wheels with 365 tires</u></b>                  a) Remove Alcoa valve                  b) Install Beru valve                  Torque valve to 102lb-in +/- 22                  c) No extension piece</p>	 <p>#Prevost 651080</p>	
	<p><b><u>Front axle and tag axle wheels with 315 tires</u></b>                  a) Remove Alcoa valve                  b) Install Beru valve                  Torque valve to 102lb-po +/- 22                  c) Small extension piece (approx 50mm)</p>	 <p>#Prevost 651081</p>	

Section 23: ACCESSORIES

<b>Aluminum wheels (new CPM wheels)</b>	<p><b><u>Drive axle inner and outer wheels with 315 tires—</u></b></p> <p>a) Remove Alco valve                  b) Install Beru valve                  Torque valve to 102lb-in +/- 22                  c) no extension piece</p>	 <p>#Prevost 651081</p>	
	<p><b><u>“Super Single” Tires</u></b></p> <p>a) Remove Alcoa valve                  b) Install Beru valve                  Torque valve to 102lb-in +/- 22                  c) no extension piece</p>	 <p>#Prevost 651079</p>	
<b>Aluminum wheels (former CPG wheels)</b>	<p><b><u>All wheels</u></b></p> <p>a) Remove Alcoa valve                  b) Install Beru valve                  Torque valve to 102lb-in +/- 22                  c) no extension piece</p>	 <p>#Prevost 651082</p>	

10.2 BERU SENSORS INSTALLATION

<p><b><i>IMPORTANT NOTE</i></b></p> <p><i>Beru sensors have a limited lifespan (5 years on average)</i></p>
---

<p>Install sensor onto valve. Torx screw T-20. Torque to 35lb-in (4Nm) (supplier specification for the screw).</p> <p>Make sure sensor rests against rim flange.</p> <p><b>IMPORTANT</b></p> <p>Use the screw only once. This screw uses a thread lock. Replacement screw #651084.</p>	
<p>Note bar code and tie it up using wheel holes. Use supplied removable tie-rap.</p>	
<p><b>Decal</b></p> <p>Glue decal facing the valve.</p>	<p>#651091 ENGLISH #651090 BILINGUAL</p>

## 11. AUTOMATIC FIRE SUPPRESSION SYSTEM (AFSS) (OPTIONAL)

This optional system is used to shut down the engine and to extinguish a fire in the engine compartment or in the vicinity of the preheating system if so equipped.

The system operation is fully automatic and does not require assistance from the operator, however if required, the system can be manually activated by the operator at any time.

Refer to Prevost Operator's Manual for system operation and operational sequence (fire).

If more information is needed on the system, please refer to Kidde Dual Spectrum "Operation & Maintenance Manual annexed at the end of this section.

## 11.1 PERIODIC MAINTENANCE

### PRE-TRIP

- Verify that the Protection Panel "SYSTEM OK" lamp is on solid green.

### EVERY 3000 MILES OR MONTHLY (whichever comes first)

#### General

- Verify that neither the protected equipment nor the hazard has changed.
- Verify that no obvious physical damage or condition exists that might prevent system operation.

#### Protection Panel

- Verify that all warning lamps and the audible alarm are operational by pressing the "TEST/RESET" button.

Manual Activation Switch

- Verify that the tamper seal is intact and access to the switch is unobstructed.

Fire Detectors

- Optical
  - Verify that the status lamp on the detector face is on solid green.
  - Verify that nothing is blocking the detector's field of view.
  - Verify that the windows on the face of the detector are free of excess contamination (dirt, oil, grease, etc.) – if necessary, clean using a water soaked non-abrasive towel.
- Linear Thermal
  - Verify that there is no obvious physical damage and that the unit is free of excess contamination (dirt, oil, grease, etc) – if necessary, clean using a water soaked non-abrasive towel.
  - Verify that mounting is secure and taught.

Electrical Harness

- Verify that electrical connectors and electrical wiring have no visible damage and all connectors are securely seated.

Extinguisher & Distribution System

- Verify that the extinguisher pressure gauge pointer is in the green arc at room temperature.
- Verify that distribution piping and nozzles are intact and unobstructed and that nozzle blow-off caps are in place.

**EVERY 18000 MILES OR SEMI-ANNUALLY**  
(whichever comes first)

- Perform a comprehensive fire system test using a Kidde Dual Spectrum System Test Set (Optical Test Kit P/N 420871-2).
- Service the extinguisher in accordance with KDS Document 160296, "KDS Pre-Engineered Fire Suppression System: Installation, Operation and Maintenance Manual".

**EVERY SIX YEARS**

- Have the fire extinguisher rebuilt by a qualified fire protection equipment company familiar with Kidde Dual Spectrum equipment and in accordance with KDS Document 160296, "KDS Pre-Engineered Fire Suppression System: Installation, Operation and Maintenance Manual". Rebuilt shall include actuator, o-ring seals and dry chemical replacement.

**EVERY TWELVE YEARS**

- Have the Extinguisher cylinder hydrostatically tested by a qualified fire protection equipment company familiar with Kidde Dual Spectrum equipment and in accordance with KDS Document 160296, "KDS Pre-Engineered Fire Suppression System: Installation, Operation and Maintenance Manual".

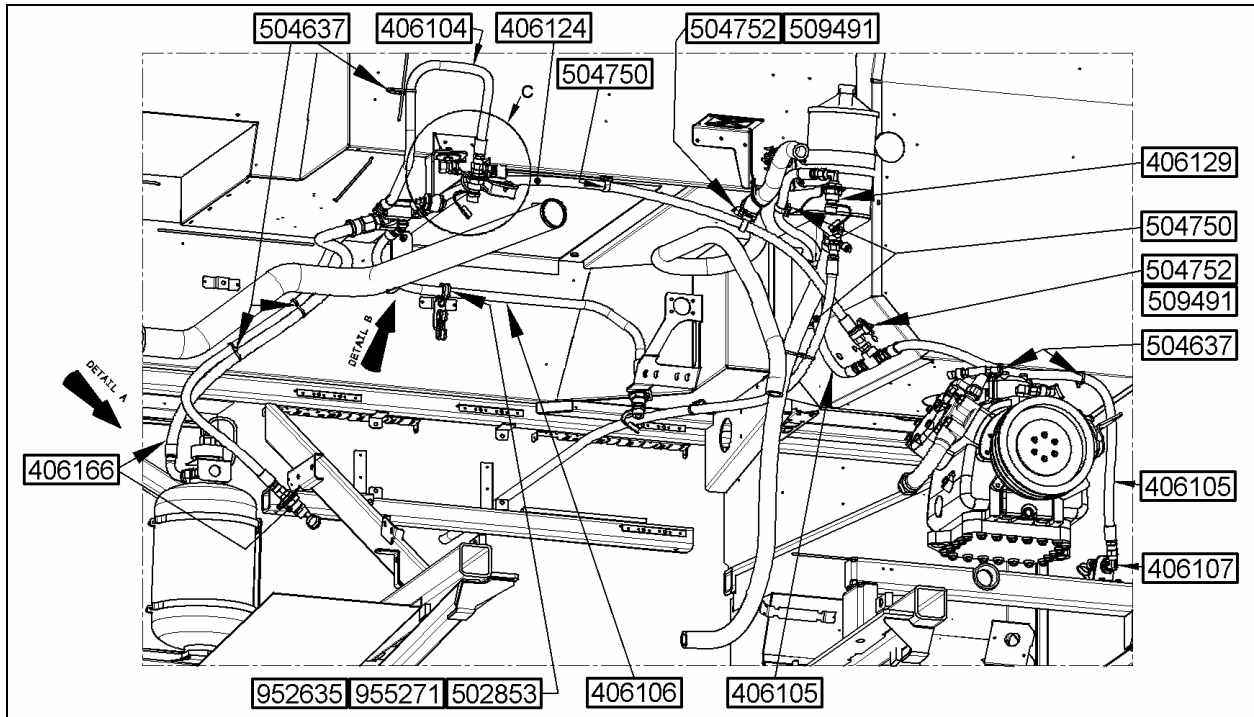

FIGURE 42: FIRE EXTINGUISHER INSTALLATION

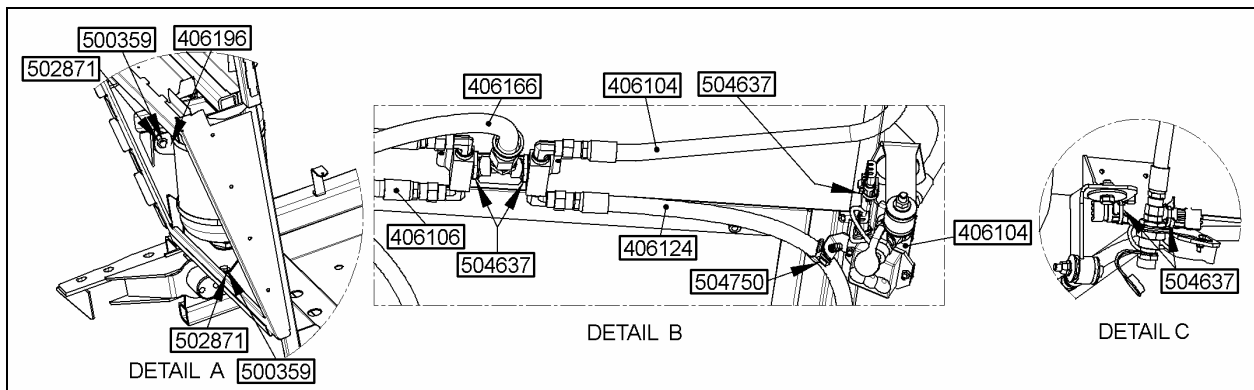

FIGURE 43: NOZZLE BRACKETS IDENTIFICATION AND INSTALLATION

**12. SPECIFICATIONS**

**AMPLIFIER**

Model..... VA400-8  
 Output..... 400 watts, 6 channel RMS at 4 ohm @ 0.5 T.H.D.  
 Prevost number..... 901191

**SOUND SELECTOR**

Model..... VSS-04  
 Power source ..... 12 volts  
 Prevost number..... 901192

**AM/FM/CD PLAYER RADIO (standard)**

Model..... VR300  
 Power source ..... 12 volts  
 Prevost number..... 901190

**AM/FM/CD SATELLITE RADIO (optional)**

Model..... VR300  
 Power source ..... 12 volts  
 Prevost number..... 901190

**6 DISC CD CHANGER**

Prevost number..... 901196

**MOBILE DVD PLAYER**

Power source ..... 12 volts  
 Prevost number..... 901198

**SPEAKER (standard)**

Model..... Dual Cone  
 Impedance ..... 4 ohms  
 Prevost number..... 901194

**SPEAKER (optional)**

Model..... Coaxial  
 Impedance ..... 4 ohms  
 Prevost number..... 901195

**SUBWOOFERS (optional)**

Model..... J Drive VB170  
 Impedance ..... 4 ohms  
 Prevost number..... 901193

**VIDEO CASSETTE PLAYER (VCP)**

Model..... V-3000  
 Prevost number..... 901030

**VIDEO SWITCHER**

Model..... V-3000  
 Prevost number..... 901030

**BOOM-TYPE MICROPHONE**

Prevost number..... 900763

**HANDHELD PRIORITY MICROPHONE**

Prevost number..... 900808



**RUBBER COATED MICROPHONE**

Prevost number ..... 900745

**16 CHANNEL WIRELESS MICROPHONE**

Make ..... R.E.I.

Prevost number ..... 900954

**16 CHANNEL WIRELESS MICROPHONE CHARGING STATION**

Make ..... R.E.I.

Prevost number ..... 900953

**16 CHANNEL WIRELESS MICROPHONE RECEIVER**

Make ..... R.E.I.

Prevost number ..... 900952

**KARAOKE**

Make ..... Panasonic

Model ..... MOBILE DVD PLAYER DV1500

Prevost number ..... 901033

**TV RECEIVER**

Power source ..... 24V

Prevost number ..... 901054

**VIDEO DISTRIBUTION AMPLIFIER**

Power source ..... 24V

Prevost number ..... 901117

**TV MONITOR**

Type ..... 10.4" LCD

Power source ..... 24V

Prevost number ..... 901130

**HUBODOMETER (US model: miles)**

Make ..... Stemco

Prevost number ..... 650002

**HUBODOMETER (Canada model: km)**

Make ..... Stemco

Prevost number ..... 650117

**ELECTRIC DESTINATION SIGN (FLUORESCENT TUBE)**

Make ..... General Electric

Length ..... 30" (76 cm)

Outside diameter ..... 1" (25 mm)

Wattage ..... 20

Color ..... Cool white

Quantity ..... 1

Prevost number ..... 830120

**ELECTRONIC DESTINATION SIGN**

Make ..... Pocatec

Prevost number ..... 940050

**LAVATORY VENTILATION FAN MOTOR**

Make..... Aurora  
Type .....RG500EF  
Voltage ..... 24 volts DC  
Rotation ..... R.H.  
Prevost number ..... 870844

**LAVATORY FLUORESCENT TUBES**

Make..... General Electric  
Model.....F15T8CW  
Length ..... 18" (45 cm)  
Wattage ..... 15  
Quantity ..... 2  
Prevost number ..... 830102

**EMERGENCY BUZZER SWITCH (PUSH BUTTON)**

Make..... Cole Hersee Co.  
Voltage ..... 24 V  
Prevost number ..... 562117

**FRESH WATER TANK**

Make..... Prévost  
Capacity ..... 18 US gal (68 liters)  
Prevost number ..... 401591

**FLUSH PUSH BUTTON PNEUMATIC TIMER**

Make..... Furnas  
Type ..... Resettable  
Time ..... 0,2 to 180 seconds  
Prévost number ..... 900348

**FLUSH PUMP**

Make..... RULE 2000  
Model number ..... 12 - 24 V  
Power source ..... 24 volts DC  
Capacity ..... 1450 GPH  
Prévost number ..... 900960

**AIR HORN**

Make..... Allied Signal Inc.  
Prévost number ..... 640093

**AIR HORN VALVE**

Make..... Allied Signal Inc.  
Prévost number ..... 640128

**WINDSHIELD WIPER MOTOR**

Make..... BOSCH  
Prévost number ..... 800328

**WIPER (BLADE)**

Make..... BOSCH  
Prévost number ..... 800329

**WIPER ARM**

Make..... BOSCH  
Prévost number ..... 800331