

# SECTION 16: SUSPENSION

## CONTENTS

<b>1. INTRODUCTION</b>	<b>4</b>
<b>2. STEERING LINKAGE</b>	<b>4</b>
2.1 POWER STEERING HYDRAULIC PUMP	7
2.2 STEERING LINKAGE ADJUSTMENT	7
2.3 PITMAN ARM REMOVAL	7
2.4 PITMAN ARM INSTALLATION	7
2.5 DRAG LINK	8
2.5.1 <i>Adjustment</i>	8
2.6 BELL CRANK AND IDLER ARM	8
2.6.1 <i>Bell Crank and Idler Arm Removal</i>	8
2.6.2 <i>Bell crank or Idler Arm Ball Joint Disassembly</i>	8
2.6.3 <i>Bell Crank or Idler Arm Ball Joint Reassembly</i>	8
2.7 RELAY ROD	10
2.7.1 <i>Replacement</i>	10
2.8 TIE RODS	10
2.8.1 <i>Removal</i>	10
2.8.2 <i>Installation</i>	11
2.9 STEERING ARMS	11
2.9.1 <i>Removal</i>	11
2.9.2 <i>Installation</i>	11
2.10 LUBRICATION FITTINGS	11
<b>3. BALL JOINTS</b>	<b>13</b>
3.1 LOWER AND UPPER A-ARM BALL JOINT	13
3.1.1 <i>Inspection</i>	13
3.1.2 <i>Stripping Down</i>	13
3.1.3 <i>Assembly</i>	14
3.2 LOWER A- ARM CENTRAL BALL JOINT	14
3.2.1 <i>Inspection</i>	14
3.2.2 <i>Stripping Down</i>	14
3.2.3 <i>Assembly</i>	14
3.3 UPPER A-ARM CENTRAL BALL JOINT	15
3.3.1 <i>Visual Inspection</i>	15
3.3.2 <i>Play Measurement</i>	15
<b>4. FRONT END ALIGNMENT</b>	<b>15</b>
4.1 ALIGNMENT TERMINOLOGY	16
4.2 FRONT END INSPECTION	16
4.3 FRONT WHEEL CAMBER	17
4.4 FRONT WHEEL TOE-IN	17
4.4.1 <i>Toe-In Check</i>	17
4.4.2 <i>Toe-In Adjustment</i>	17
4.5 FRONT AXLE CASTER	17
4.6 MAJOR DAMAGE	19
<b>5. FRONT AIR SPRINGS</b>	<b>19</b>
5.1 INSPECTION	19
5.2 REMOVAL	19
5.3 INSTALLATION	19
<b>6. SHOCK ABSORBERS</b>	<b>20</b>

## Section 16: SUSPENSION

---

6.1	SHOCK ABSORBER REMOVAL .....	21
6.2	SHOCK ABSORBER INSTALLATION .....	21
<b>7.</b>	<b>SWAY BAR .....</b>	<b>21</b>
7.1	REMOVAL .....	21
7.2	INSTALLATION .....	21
<b>8.</b>	<b>REAR SUSPENSION .....</b>	<b>23</b>
8.1	AIR SPRINGS .....	24
8.1.1	<i>Inspection</i> .....	24
8.1.2	<i>Removal</i> .....	24
8.1.3	<i>Installation</i> .....	24
8.2	SHOCK ABSORBERS .....	25
8.2.1	<i>Inspection</i> .....	25
8.2.2	<i>Removal</i> .....	26
8.2.3	<i>Installation</i> .....	26
8.3	RADIUS RODS .....	26
8.3.1	<i>Inspection</i> .....	27
8.3.2	<i>Removal</i> .....	27
8.3.3	<i>Bushing removal</i> .....	27
8.3.4	<i>Bushing installation</i> .....	27
8.3.5	<i>Installation</i> .....	28
<b>9.</b>	<b>SUSPENSION HEIGHT ADJUSTMENT .....</b>	<b>28</b>
<b>10.</b>	<b>HEIGHT CONTROL VALVE .....</b>	<b>29</b>
10.1	LOADING POSITION .....	30
10.2	NEUTRAL POSITION .....	30
10.3	UNLOADING POSITION .....	30
10.4	MAINTENANCE .....	30
10.5	REMOVAL AND INSTALLATION .....	30
<b>11.</b>	<b>"LEVEL-LOW" LEVELING SYSTEM .....</b>	<b>30</b>
11.1	PRINCIPLES OF OPERATION .....	31
11.2	MAINTENANCE .....	31
<b>12.</b>	<b>AIR SYSTEM .....</b>	<b>31</b>
12.1	AIR TANK MAINTENANCE .....	32
12.1.1	<i>Wet Air Tank</i> .....	32
12.1.2	<i>Primary Air Tank</i> .....	32
12.1.3	<i>Secondary Air Tank</i> .....	32
12.1.4	<i>Accessory Air Tank</i> .....	32
12.1.5	<i>Expansion Air Tank</i> .....	33
12.2	EMERGENCY FILL VALVES .....	33
<b>13.</b>	<b>HUB UNIT AND SWIVEL ASSEMBLY .....</b>	<b>33</b>
13.1	HUB BEARING INSPECTION .....	33
13.2	KING PIN INSPECTION .....	33
13.2.1	<i>Checking Lateral Slackness</i> .....	33
13.2.2	<i>Checking Vertical Slackness</i> .....	34
<b>14.</b>	<b>TORQUE TABLE .....</b>	<b>35</b>
<b>15.</b>	<b>SPECIFICATIONS .....</b>	<b>36</b>

## ILLUSTRATIONS

FIGURE 1: SUSPENSION AND STEERING LINKAGE.....	4
FIGURE 2: LOCATION OF CLAMPS .....	5
FIGURE 3: CLAMP POSITIONING.....	6
FIGURE 4: CLAMP POSITIONING.....	6
FIGURE 5: CLAMP POSITIONING.....	6
FIGURE 6: CLAMP POSITIONING.....	6
FIGURE 7: CLAMP POSITIONING.....	6
FIGURE 8: CLAMP POSITIONING.....	6
FIGURE 9: PITMAN ARM ALIGNMENT.....	7
FIGURE 10: FIXING NUT PUNCH MARK.....	8
FIGURE 11: BELL CRANK AND IDLER ARM.....	9
FIGURE 12: BELL CRANK .....	9
FIGURE 13: BELL CRANK .....	10
FIGURE 14: LUBRICATION FITTINGS' LOCATION DIAGRAM.....	12
FIGURE 15: BALL JOINTS LOCATION.....	13
FIGURE 16: A-ARM BALL JOINTS.....	13
FIGURE 17: LOWER A-ARM BALL JOINT .....	14
FIGURE 18: UPPER A-ARM BALL JOINTS .....	14
FIGURE 19: LOWER A-ARM CENTRAL BALL JOINT .....	15
FIGURE 20: UPPER A-ARM CENTRAL BALL JOINT.....	15
FIGURE 21: STEERING LINKAGE MEASURE .....	16
FIGURE 22: FRONT END ALIGNMENT DIAGRAM.....	18
FIGURE 23: AIR SPRINGS.....	19
FIGURE 24: AIR SPRING AND SHOCK ABSORBER.....	20
FIGURE 25: SHOCK ABSORBER .....	21
FIGURE 26: SWAY BAR (FRONT SUSPENSION) .....	22
FIGURE 27: SWAY BAR (REAR SUSPENSION) .....	22
FIGURE 28: REAR SUSPENSION COMPONENTS .....	23
FIGURE 29: DETAILS OF REAR SUSPENSION .....	23
FIGURE 30: TAG AXLE SUSPENSION .....	23
FIGURE 31: AIR SPRING.....	24
FIGURE 32: SHOCK ABSORBER .....	26
FIGURE 33: TYPICAL SHOCK ABSORBER SETUP .....	26
FIGURE 34: TYPICAL RADIUS ROD SETUP .....	26
FIGURE 35: RADIUS ROD BUSHING REMOVAL.....	27
FIGURE 36: RADIUS ROD BUSHING INSTALLATION .....	27
FIGURE 37: RADIUS ROD INSTALLATION .....	28
FIGURE 38: HEIGHT CONTROL VALVE LOCATION.....	28
FIGURE 39: TYPICAL AIR SPRING CLEARANCE .....	28
FIGURE 40: FRONT HEIGHT CONTROL VALVE.....	29
FIGURE 41: REAR HEIGHT CONTROL VALVE.....	29
FIGURE 42: LOCATION OF AIR TANKS.....	31
FIGURE 43: REAR VALVE LOCATION.....	32
FIGURE 44: FRONT VALVE LOCATION.....	32

**1. INTRODUCTION**

The vehicle is provided with an air suspension system. The system consists of air springs, height control valves, tie rods, radius rods, sway bars, tripod and shock absorbers. The system operation is fully automatic and maintains a constant vehicle height regardless of load, or load distribution.

**2. STEERING LINKAGE**

Turning motion of the steering wheel is transferred by the steering gear and steering linkage to the steering arms at the right and left front wheels. The steering linkage consists of tie rods connected to the bell crank and the steering arm at the left side of the bus shell, and to the idler arm and steering arm at the right side of the bus shell. The bell crank and idler arm are connected by a relay rod. A drag link connected to the bell crank and the pitman arm, which is

mounted to the steering gear, transfers the turning motion of the steering wheel to the steering arms. The hydraulic power cylinder provides an added source of assistance and being connected to the R.H. wheel, makes it such that the total steering forces are produced with minimal stress on mechanical linkages (Fig. 1).

Lower and upper A-arms are widely spaced. They are mounted on ball joints. Torque rods prevent rotation of the uprights around the lower and upper ball joints.

If the steering linkage is bent, twisted or worn, steering action of the vehicle will be seriously affected. Any time steering linkage components are replaced or adjusted, steering geometry and front wheel alignment must be checked as explained in this section.

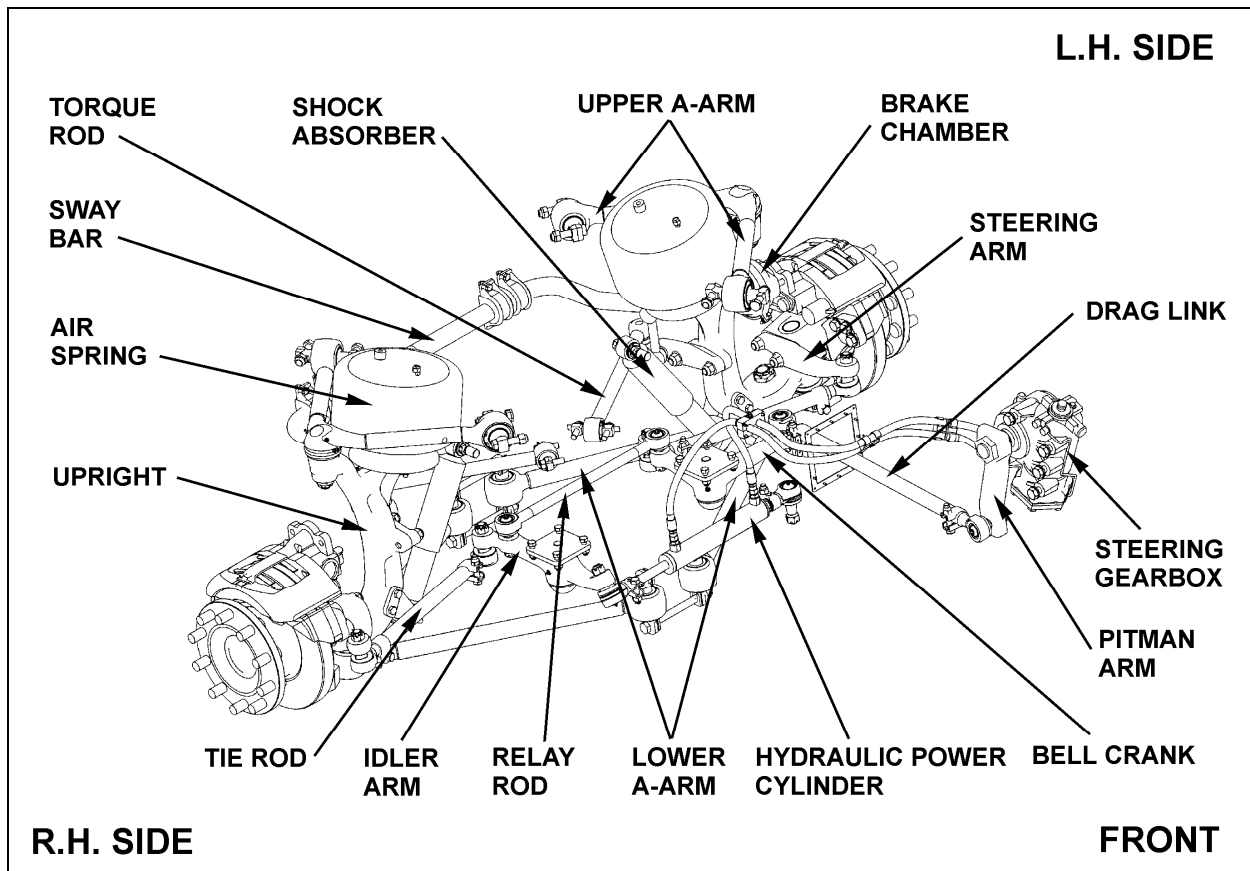

FIGURE 1: SUSPENSION AND STEERING LINKAGE

16124

### Turning Angle

The maximum turning angle is set mechanically through the two steering stop screws installed on the swivel assembly. The turning angle ( $56^{\circ} + 0^{\circ} - 1^{\circ}$ ) mechanical stop is factory adjusted to accommodate the chassis design, and therefore, does not require adjustment on new vehicles.

However, turning angle should be checked and adjusted hydraulically, if necessary, any time a component of the steering system is repaired, disassembled or adjusted.

Before checking the turning angle, be sure the front end is properly aligned as described under paragraph "4. Front End Alignment" in this section.

To check steering maximum turning angle, proceed with the following method:

1. Check if front tires rub against the frame or if the steering gear has been serviced.



### CAUTION

If clamps are not correctly installed, they can interfere with other parts.

2. For a full left and right turn, check clamps' position and for interfering parts. Refer to figures 2 to 7 for location and positioning of clamps. If readjustment is required, make the proper adjustment.

### NOTE

*Prior to steering limiter adjustment, verify vehicle wheel alignment, and ensure that oil level is adequate and that air bleeding is done.*

3. If necessary readjust steering limiter. Refer to "ZF-SERVOCOM Repair Manual" annexed to Maintenance Manual, Section 14, "Steering", under heading: "Setting and Functional Test".

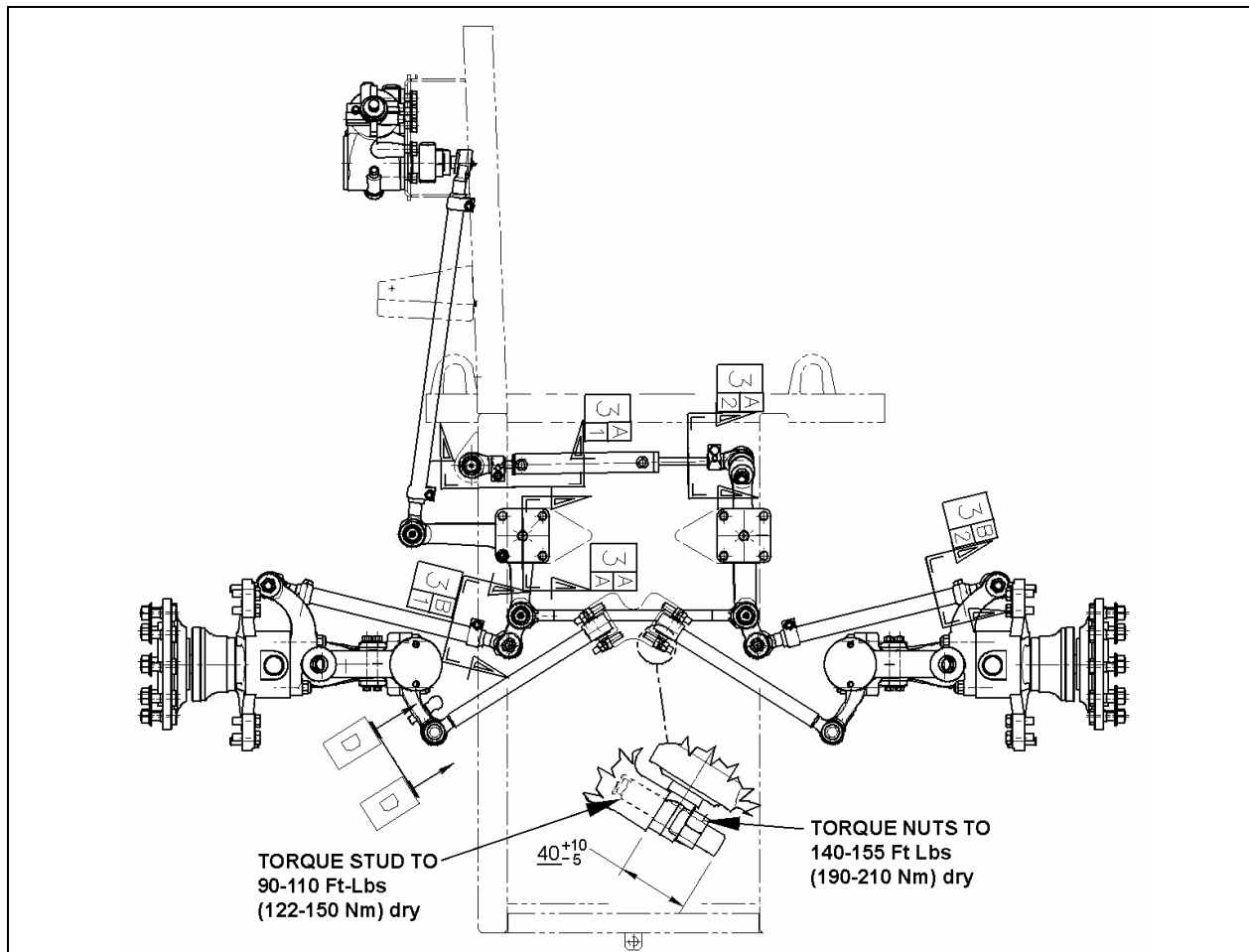

FIGURE 2: LOCATION OF CLAMPS

16177

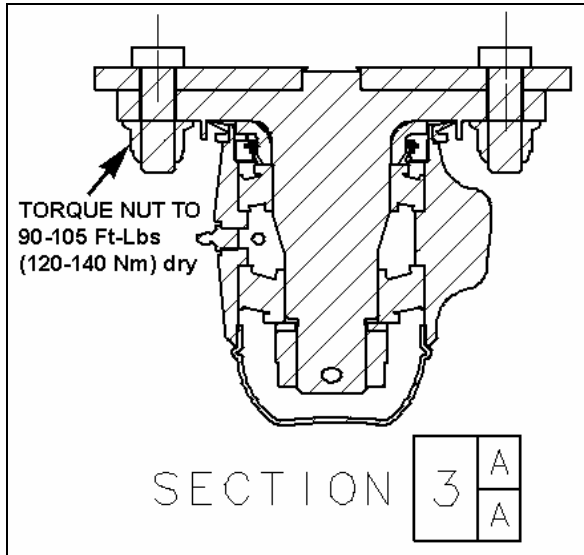

FIGURE 3: CLAMP POSITIONING

16169

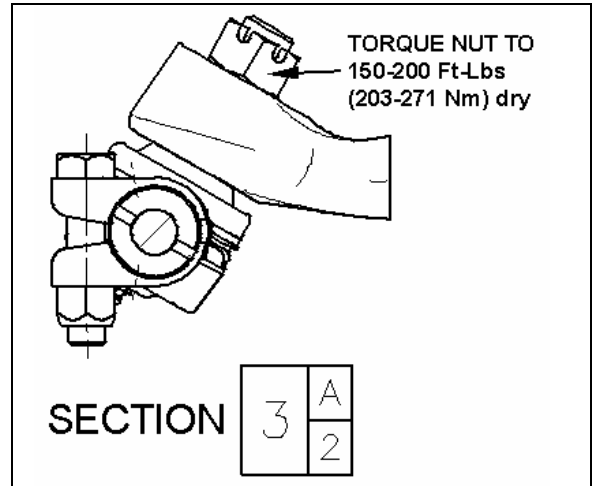

FIGURE 6: CLAMP POSITIONING

16179

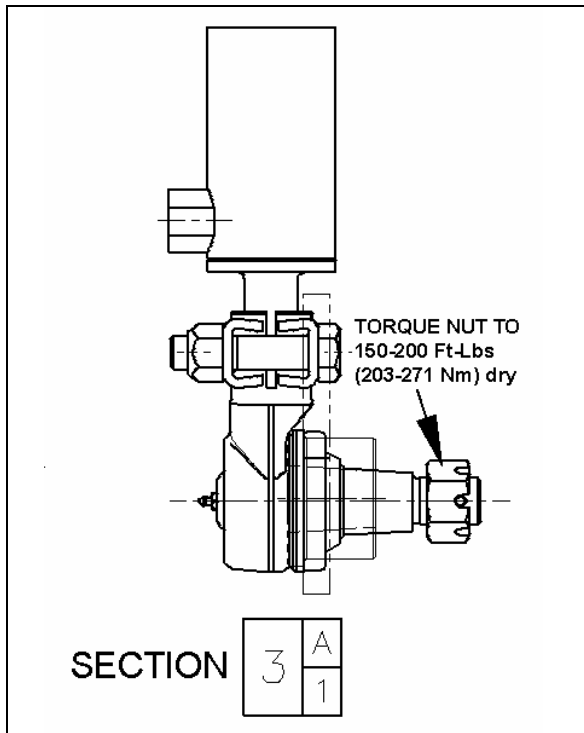

FIGURE 4: CLAMP POSITIONING

16178

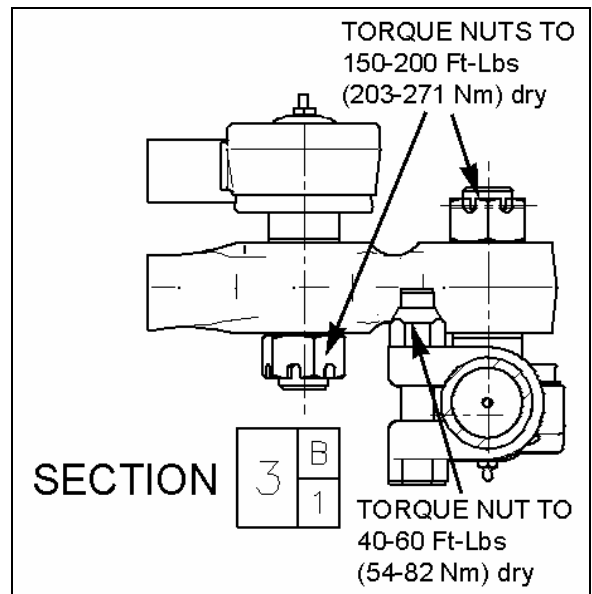

FIGURE 7: CLAMP POSITIONING

16170

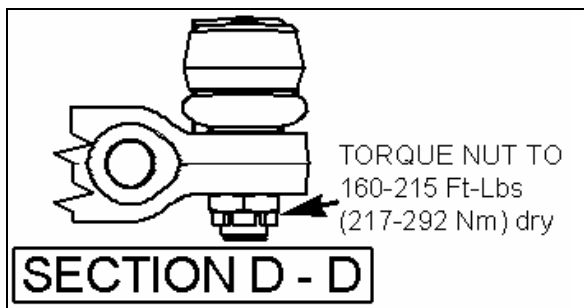

FIGURE 5: CLAMP POSITIONING

16172

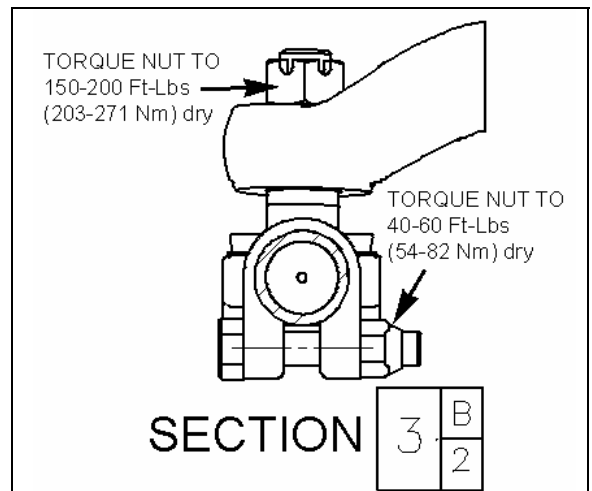

FIGURE 8: CLAMP POSITIONING

16171

2.1 POWER STEERING HYDRAULIC PUMP

With DDC Series 60 Engine, refer to the "TRW Power Steering Pump Service Manual" annexed at the end of Section 14

2.2 STEERING LINKAGE ADJUSTMENT

**NOTE**  
Whenever a steering linkage component has been removed and replaced, check steering geometry and front end alignment as directed in this Section. Check to insure that all stud nuts and mounting bolts and nuts have been tightened to proper torques listed under "14. Torque Table" at the end of this section.

1. First, align the input shafts marks.
2. Afterwards, the pitman arm should be adjusted with reference marks aligned or to an angle of 90° in relation with the horizontal axis (Fig. 9).
3. Locate centerline of vehicle then install relay rod in boss at steering bell crank and idler arm. Align center of relay rod with centerline of vehicle.
4. Install drag link to pitman arm and adjust opposite end of drag link to fit mounting stud hole in bell crank.
5. Install tie rods, and then adjust toe-in as per "Front End Alignment" in this Section.

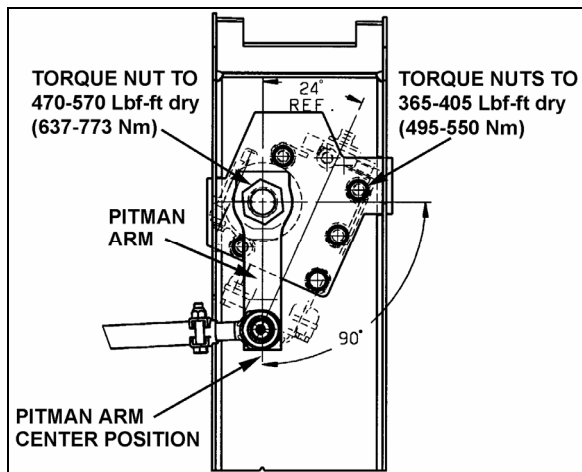





FIGURE 9: PITMAN ARM ALIGNMENT 14057

2.3 PITMAN ARM REMOVAL

1. Remove cotter pin, nut and washer from drag link ball stud at pitman arm.
2. Disconnect drag link from pitman arm, using jaw style pullers (pressure screw type).

 **WARNING**  
Always wear approved eye protection when operating pullers.

 **CAUTION**  
Do not drive pitman arm on or off pitman shaft as this can damage the steering gear.

 **CAUTION**  
Heating of components to aid in disassembly is not allowed because it has a detrimental effect on axle components and steering linkages.

3. Remove pitman arm fixing nut.
4. Check the radial position of the pitman arm in relation to the sector shaft prior to removal of pitman arm.
5. Add reference marks to the arm and shaft if necessary to ensure correct alignment at reassembly.
6. Use a puller to remove pitman arm.

2.4 PITMAN ARM INSTALLATION

1. Position pitman arm on sector gear shaft with reference marks aligned.
2. Install fixing nut. Tighten nut to 470-570 lbf-ft (637-773 Nm).

**NOTE**  
Use a new nut if the previously removed nut was punched.

 **CAUTION**  
Lock nut with sector shaft using a punch mark into the groove (Refer to figure 10).

3. Connect drag link to pitman arm. Install washers. Tighten nut to 150-200 lbf-ft (203-271 Nm). Advance nut to next alignment cotter pin slot and install a new cotter pin.

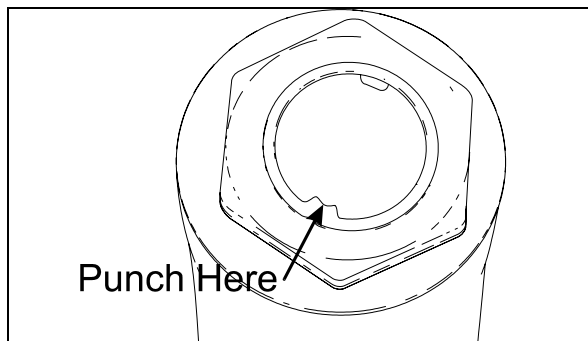

FIGURE 10: FIXING NUT PUNCH MARK 16098

## 2.5 DRAG LINK

Drag link assembly consists of three parts; a drag link and two end assemblies. Both end assemblies are identical and they are retained on the drag link with a clamp bolt and nut.

Stud nuts at the pitman arm and bell crank ends of the drag link must be kept tight or hole at ball stud end of drag link and hole in pitman arm may become enlarged as a result of excessive looseness. Subsequent tightening of stud nuts may draw studs too far into holes and dust cover parts may become damaged which can result in component failure.

Drag link end sockets are equipped with lubrication fittings and should be lubricated as directed in "Lubrication Fittings" in this Section.

### 2.5.1 Adjustment

It should not be necessary to alter the length of the drag link except when a new link is installed or when removable end assembly has been replaced. If drag link adjustment is necessary, proceed as follows:

1. Position front wheels in straight ahead position.
2. Center steering gear as previously explained in paragraph "2.2 Steering Linkage Adjustment".
3. Remove cotter pin, nut and stud from drag link at bell crank. Locate centerline of vehicle and center of relay rod. With center of relay rod aligned with centerline of vehicle, loosen clamp bolt at socket end (bell crank end) of drag link and adjust length of socket end assembly to fit in boss of bell crank.

**NOTE**

Do not change position of pitman arm.

4. Install stud with nut and torque to 150-200 lbf-ft (203-271 Nm). Align nut with cotter pin slot (tighten) and install a new cotter pin.
5. Torque mounting clamp bolt nut to 40-60 lbf-ft (55-80 Nm), then test the adjustment. Front wheels should turn from right to left extremities without noticeable binding at drag link ends.

## 2.6 BELL CRANK AND IDLER ARM

Bell crank and idler arm are equipped with one lubrication fitting and should be lubricated as directed in paragraph "2.10 Lubrication Fittings" at the end of this Section.

### 2.6.1 Bell Crank and Idler Arm Removal

**NOTE**

Use a piece of wire to anchor loosen end of relay rod and tie rod in order to prevent placing an excessive load on opposite socket end.

**Bell crank:** Disconnect drag link, tie rod and relay rod from bell crank by removing cotter pins and nuts from ball studs. Separate socket assemblies from the bell crank.

**Idler arm:** Remove cotter pins and nuts from ball studs connecting relay rod, tie rod and hydraulic power cylinder to idler arm. Separate socket assemblies from idler arm.

Remove nuts from bolts attaching bell crank or idler arm mounting spindle to suspension subframe. Remove bell crank or idler arm mounting spindle.

### 2.6.2 Bell crank or Idler Arm Ball Joint Disassembly

1. Remove adjacent link assemblies from bell crank or idler arm as previously described.
2. Remove the cap (Fig. 11).
3. Remove the cotter pin, nut and thrust washer. Remove bearings, grease retainer, backup ring and the bell crank or idler arm from its mounting spindle (Fig. 11).

### 2.6.3 Bell Crank or Idler Arm Ball Joint Reassembly

**NOTE**

For bearing installation use Prévost tool # 110684.



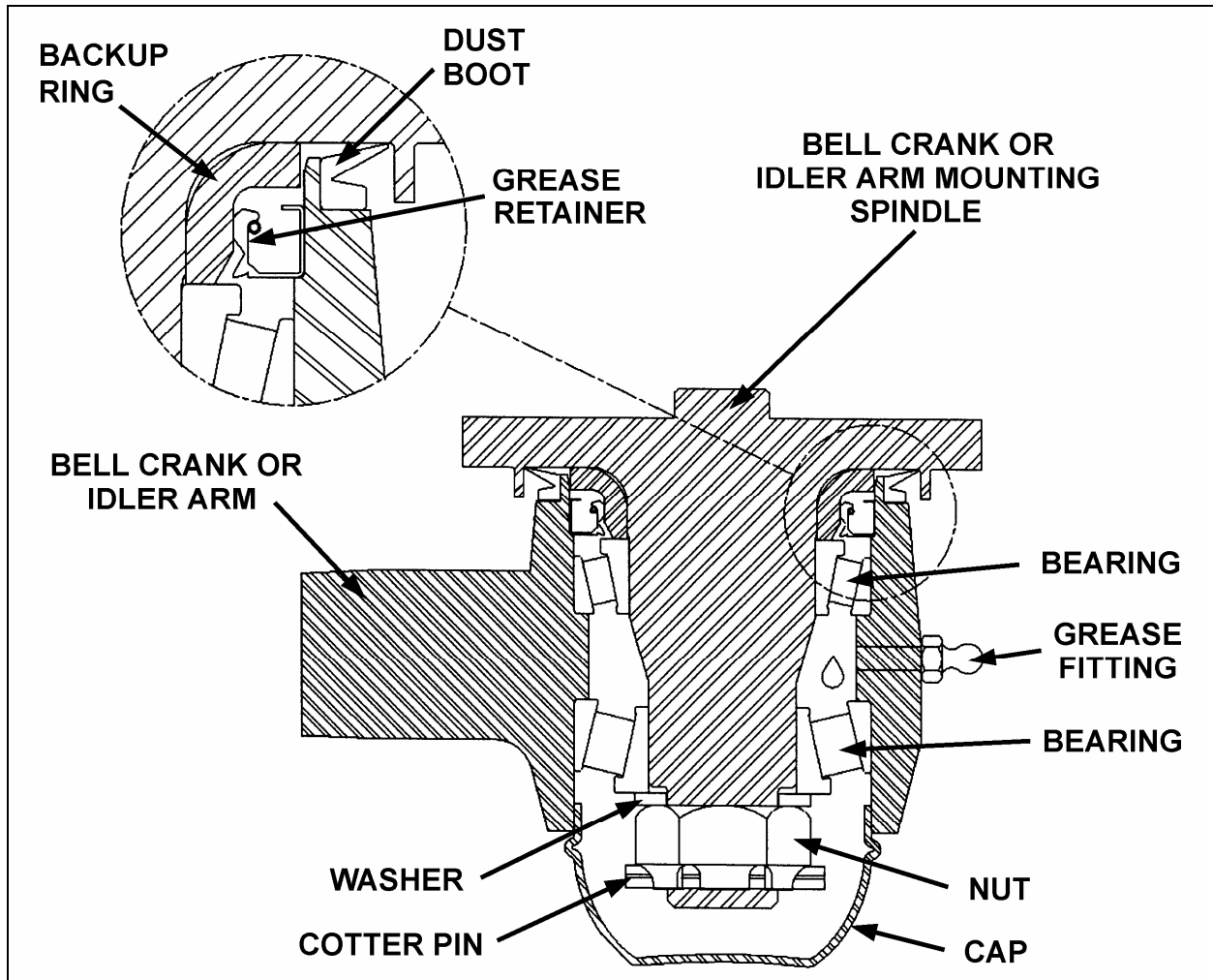

FIGURE 11: BELL CRANK AND IDLER ARM

16109

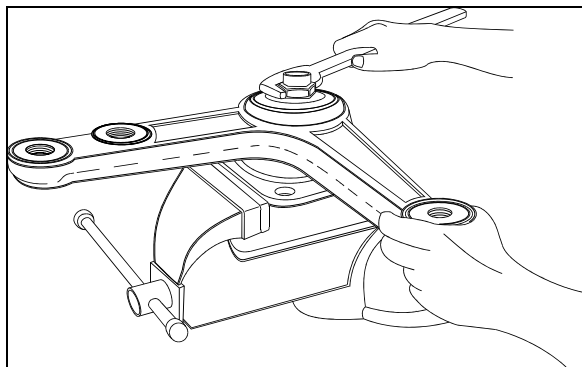

FIGURE 12: BELL CRANK

16044

1. Install backup ring on bell crank or idler arm mounting spindle.
2. Install grease retainer and bearing in bell crank or idler arm eye (Fig. 11).

**NOTE**

Install grease retainer according to figure 11. Grease must be able to exit the bell crank or idler arm mechanism. For grease retainer installation use tool Prévost # 110683.

3. Install bell crank or idler arm onto its mounting spindle, while holding the bell crank or idler arm, slide on the bearing assembly, thrust washer and secure using nut. (Fig. 12).

**NOTE**

Apply grease on bearing before installation.

4. Unscrew nut until bell crank or idler arm starts to turn by the application of 1 to 3 pounds load (Fig. 13).

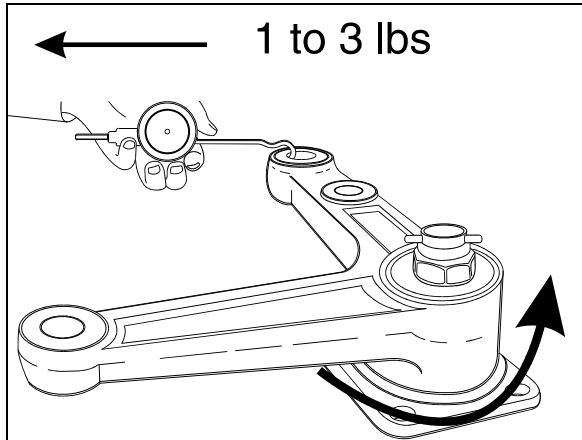

FIGURE 13: BELL CRANK 16045

5. Check for loose bearings by applying an up and down load on bell crank or idler lever. The lever is not supposed to move in the vertical axis direction.
6. Align nut with cotter pin slot (tighten) and install a new cotter pin.

**NOTE**

*Bend cotter pin around the nut (Fig. 11). Do not bend the cotter pin in the direction of the cap, because it may interfere with the cap.*

7. Install the cap.
8. **Bell crank:** Install drag link, tie rod and relay rod as directed herein under each specific subject.
9. **Idler arm:** Install hydraulic power cylinder, tie rod and relay rod as directed herein under each specific subject.
10. Adjust turning angle as previously directed under paragraph "**Turning Angle**" and check front end alignment as specified in paragraph "4. Front End Alignment" of this Section.

2.7 RELAY ROD

Relay rod ends are equipped with lubrication fittings and should be lubricated as directed in paragraph "2.10 Lubrication Fittings" in this Section.

**NOTE**

*The relay rod is crimped in place and it is not possible to remove the ball joints.*

2.7.1 Replacement

1. Remove cotter pins from bell crank and idler arm end of relay rod. Loosen nuts flush with end of studs.
2. Use a puller or place a sledge hammer behind the adjacent part to absorb shocks. Strike the studs with a brass hammer to loosen end assemblies.
3. Remove stud nuts then remove studs.
4. Position new relay rod studs into bell crank and idler arm then tap stud ends with a brass hammer to seat tapered surfaces.
5. Install stud nuts. Tighten nuts to 150-200 lbf-ft (203-271 Nm) torque. Align cotter pin slot (tighten) and install a new cotter pin.

2.8 TIE RODS

Tie rod ends are connected to the bell crank and left steering arm, and to the idler arm and right steering arm. Each tie rod assembly consists of three parts; a tube and two socket end assemblies. The tie rod ends are threaded into the tube and secured with clamp bolts. Right and left hand threads are provided to ease toe-in adjustment. Tie rod assemblies are interchangeable from the right to the left side of the coach.

Tie rod end sockets require no maintenance other than periodic lubrication and inspection to see that ball studs are tight. Replace socket ends when there is excessive up and down motion, lost motion or end play at ball end of stud.

1. Periodically check bolt nut for tightness.
2. Inspect tie rod for bent condition and inspect tube for damaged threads. If tie rod is bent or threads are damaged, replace the assembly.
3. Lubricate tie rod end fittings as directed in paragraph "2.10 Lubrication Fittings" in this section.

2.8.1 Removal

1. Remove cotter pins and stud nuts which attach tie rod socket ends to bell crank and left steering arm (or idler arm) and right steering arm.

- Remove tie rod ball stud by tapping on steering arm and bell crank or idler arm with hammer, while using a sledge hammer to absorb shocks.

**NOTE**

*If tie rod end assemblies are damaged in any way, they must be replaced.*

## 2.8.2 Installation

- Install socket end assemblies on tie rod. Be sure both ends are threaded an equal distance into the tube.
- Make sure threads on stud and in stud nut are clean and not damaged.
- Position ball studs (socket ends of tie rod) in holes in steering arm and bell crank or idler arm. Install a ball stud nut on each stud and tighten firmly.
- Torque stud nuts to 150-200 lbf-ft (203-271 Nm). Align cotter pin slot (tighten) and install a new cotter pin.

**NOTE**

*Adjust toe-in as directed in paragraph "4.4.2 Toe-In Adjustment" of this Section.*

- Make sure tie rod ends are properly aligned with ball studs, then torque tie rod end clamp bolts to 40-60 lbf-ft (55-80 Nm).

**NOTE**

*If tie rod is not properly aligned with stud, binding will result.*

## 2.9 STEERING ARMS

The left and right wheel steering arms are secured to a steering knuckle at one end and to a tie rod at the other end.

## 2.9.1 Removal

- Remove wheel as directed in Section 13, "Wheel, Hubs And Tires" of the maintenance manual.
- Remove cotter pin and nut from stud securing tie rod to steering arm. Remove ball stud from steering arm by tapping on arm with a hammer, placing a sledge hammer underneath steering arm to absorb shocks.

- Remove bolts securing steering arm to steering knuckle assembly. Remove steering arm from steering knuckle.

## 2.9.2 Installation

- Install steering arm onto steering knuckle.
- Torque steering arm to steering knuckle fixing bolts. Torque short bolt (M20 X 65) to 520-575 lbf-ft (705-780 Nm). Torque long bolt (M24 X 100) to 751-830 lbf-ft (1018-1125 Nm).
- Position tie rod ball stud in steering arm and tap with a brass hammer to seat ball stud in steering arm. Install nut on stud. Torque nut to 150-200 lbf-ft dry (203-271 Nm). Tighten nut to nearest cotter pin slot and install a new cotter pin.
- Install wheel as directed in Section 13, "Wheel, Hubs And Tires" under paragraph "3.2 Installation" of the maintenance manual.

## 2.10 LUBRICATION FITTINGS

All lubrication fittings must be clean before applying lubricant. Also, always be sure equipment used in applying lubricant is clean. Every precaution should be taken to prevent entry of dirt, grit, lint or other foreign matter into lubricant containers. Replace fitting when they become broken or damaged.

Intervals of application given in the following paragraphs are recommended for normal service. More frequent intervals may be applied under severe operating conditions. In selecting proper lubricants, supplier reputation must be considered. The supplier must be responsible for product quality. The diagram (Fig. 14) shows approximate location of steering lubrication fittings.

- Drag Link Ends:** Lubricate at two fittings, one at each end of link, every 6,250 miles (10 000 km) with good quality lithium-base grease NLGI No. 2 (Shell Retinax LX or equivalent).
- Relay Rod Ends:** Lubricate at two fittings, one at each end of rod, every 6,250 miles (10 000 km) with good quality lithium-base grease NLGI No. 2 (Shell Retinax LX or equivalent).
- Tie Rod Ends:** Lubricate at four fittings, one at each end of both tie rods, every 6,250 miles (10 000 km) with good quality lithium-

## Section 16: SUSPENSION

base grease NLGI No. 2 (Shell Retinax LX or equivalent).

4. **Swivel Assembly:** Refer to DANA SPICER MAINTENANCE MANUAL NDS AXLES Lubrication and Maintenance" annexed at the end of section 11.
5. **Idler Arm and Crank bell:** Lubricate at two fittings, one on the idler arm and the other on the crank bell, every 6,250 miles (10 000 km) with good quality lithium-base grease NLGI No. 2 (Shell Retinax LX or equivalent). Apply grease gun pressure to the fitting until lubricant appears at the top seal.

6. **Upper A-Arm Central Ball Joint:** Lubricate at fitting until you see some grease on the relief valve nearby, every 6,250 miles (10 000 km) with good quality lithium-base grease NLGI No. 2 (Shell Retinax LX or equivalent).

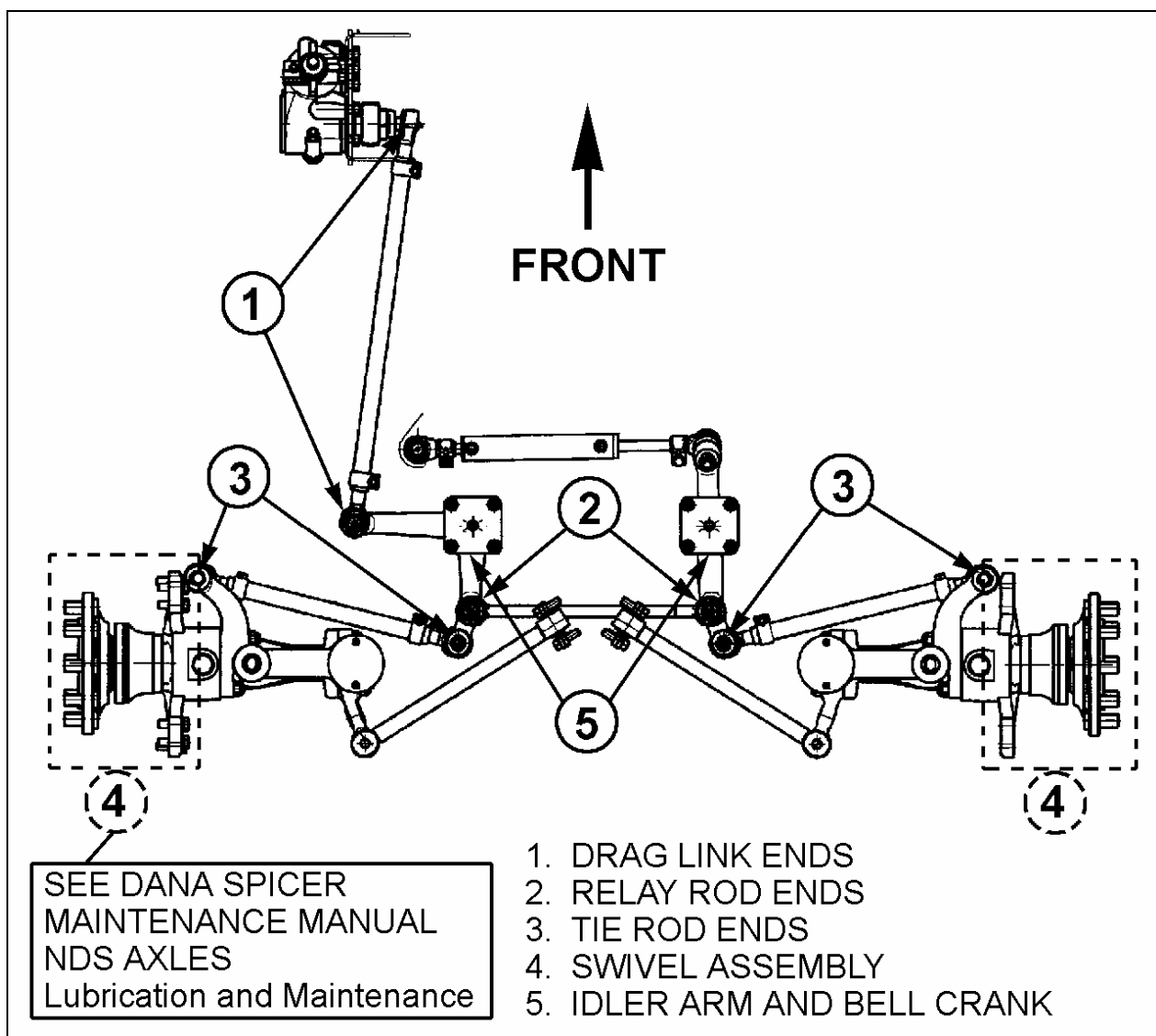

FIGURE 14: LUBRICATION FITTINGS' LOCATION DIAGRAM

16118

### 3. BALL JOINTS

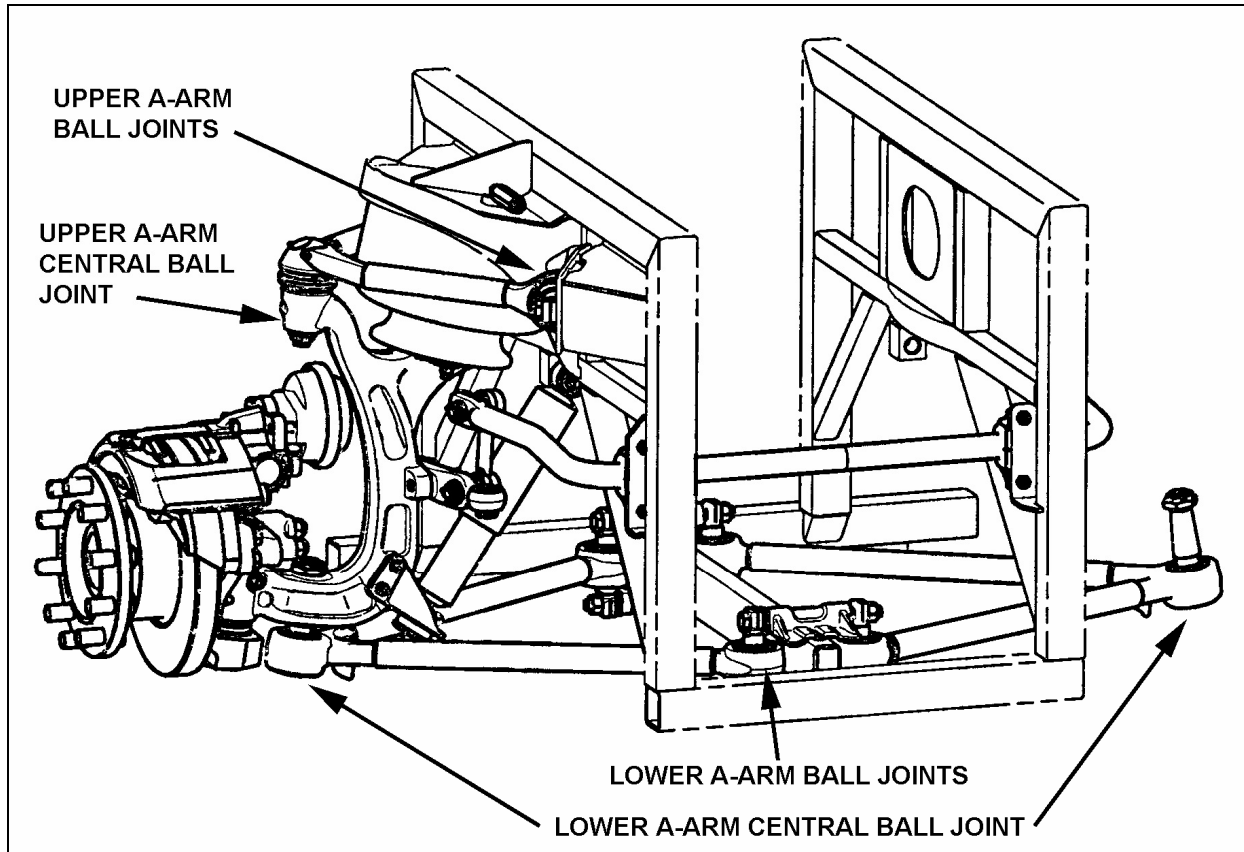

FIGURE 15: BALL JOINTS LOCATION

16137

#### 3.1 LOWER AND UPPER A-ARM BALL JOINT

The assembly work may be done only by a recognized specialized workshop. Ensure that old and new parts do not get mixed up with each other. It is for this reason that all the old parts are to be scrapped immediately after a joint has been stripped down. A complete repair set must be used for each joint repaired, i.e. use of only part of a repair set is not permissible.

##### 3.1.1 Inspection

Take off the load from the ball joint by lifting the front of the vehicle. Apply a load on the joint in all of the degrees of freedom in an axial, radial, etc. sense with a suitable lever tool. After the load is taken off, the joint has to spring back into its starting position. Free play is not acceptable.

Separation of rubber from ball pin or external joint shell is in accordance with "normal wear characteristics".

When the following characteristics are noted, the joint is to be changed:

- Free play;
- Radial cracking of the external sheet-metal race.

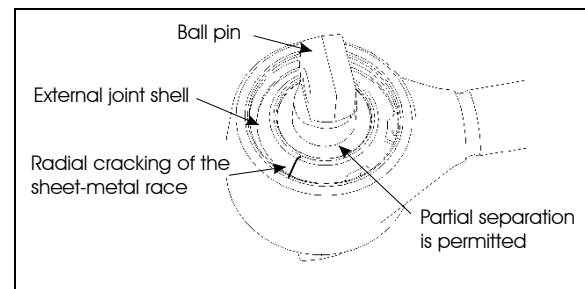

Figure 16: A-ARM BALL JOINTS

##### 3.1.2 Stripping Down

Strip down the defective joint through removal of retaining ring, annular spacer and ball pin/bushing assembly and thereafter clean out housing bore and locking circlips groove.

## Section 16: SUSPENSION

### 3.1.3 Assembly

Execute assembly of the new joint parts in the following sequence:

1. Complete moistening of the contact surface between housing bore and ball pin through application of the grease.

#### **NOTE**

*Apply grease, only in the case of repair kit (Prévost # 611114).*

2. Insert ball pin/bushing assembly. In case of the two-bolt type, ensure that the bolt bores are in the correct position in relation to the axis of the tube.

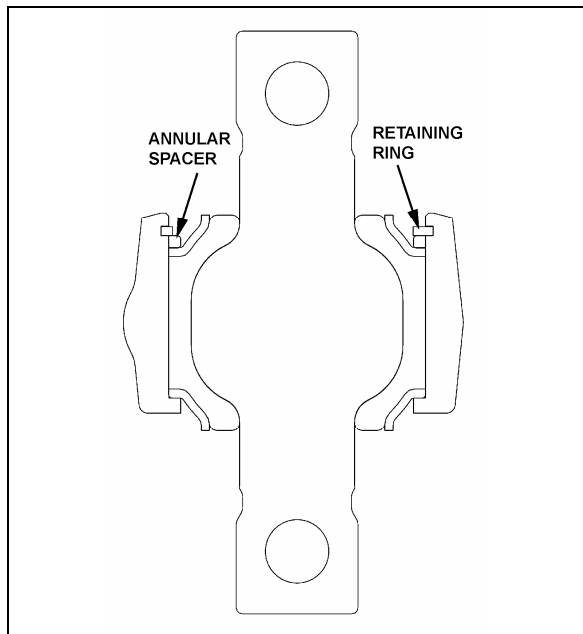

FIGURE 17: LOWER A-ARM BALL JOINT

16114

3. Place joint in receiving fixture and mount annular assembly tool on the housing. Then locate annular spacer and retaining ring in the housing using axial load with the aid of assembly matrix. If the ends of the annular spacer are not in contact with each other, the thus formed opening must be located at 180° to the opening of the retaining ring. Pay attention during assembly to ensure that the retaining ring eyelets are located at each side of the housing shaft axis (retaining ring eyelet lug points to tube), and that retaining ring is properly engaged in the groove of the housing.
4. When repairing defective ball pin assemblies, the necked down-bolt must regularly be replaced with a new one.

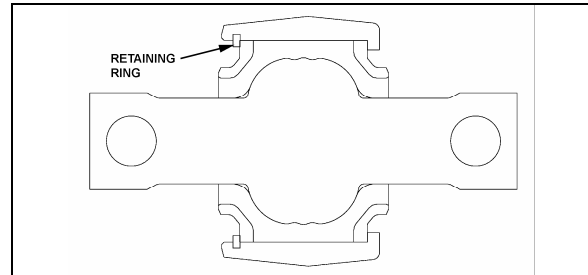

FIGURE 18: UPPER A-ARM BALL JOINTS

16115

### 3.2 LOWER A- ARM CENTRAL BALL JOINT

#### 3.2.1 Inspection

Take off the load from the ball joint by lifting the front of the vehicle. Apply a load on the joint in all of the degrees of freedom in an axial, radial, etc. sense with a suitable lever tool. After the load is taken off, the joint has to spring back into its starting position. Free play is not acceptable.

Separation of rubber from ball pin or external joint bushing shell is in accordance with "normal wear characteristics".

When the following characteristics are noted, the joint is to be changed:

- Free play;
- Radial cracking of the external bushing shell.

#### 3.2.2 Stripping Down

Strip down the defective joint through removal of retaining ring, annular spacer and ball pin/bushing, assembly and thereafter clean out housing bore and locking circlips groove

#### 3.2.3 Assembly

Assemble the new component parts of the joint in the following sequence:

1. Complete moistening of the contact surface between housing bore and ball pin through application of the grease.
2. Place joint in receiving fixture and mount annular assembly tool on the housing. Then locate annular spacer and retaining ring in the housing using axial load with the aid of assembly matrix. If the ends of the annular spacer are not in contact with each other, the thus formed opening must be located at 180° to the opening of the retaining ring. Pay attention during assembly to ensure that the retaining ring eyelets are located at each side of the housing shaft axis (retaining ring eyelet lug points to tube), and that retaining ring is properly engaged in the groove of the housing.

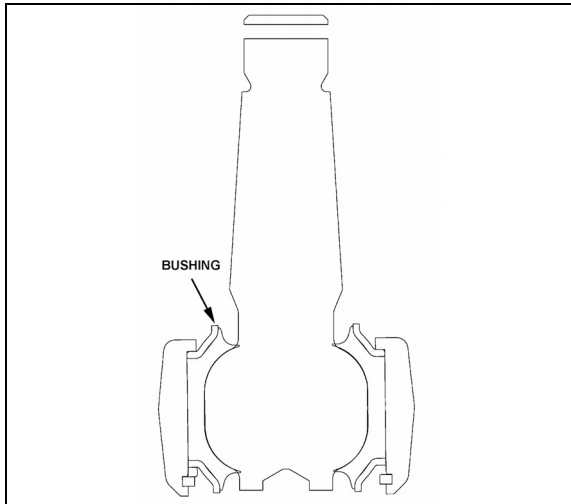

FIGURE 19: LOWER A-ARM CENTRAL BALL JOINT

3. Faultlessly apply grease by mechanical means to bracket-outer core and ball-inner cone. Insert bracket outer cone in fixture with distance ring and then use press tool to apply pressure to press mount with ball-inner cone.

### 3.3 UPPER A-ARM CENTRAL BALL JOINT

#### 3.3.1 Visual Inspection

Check the condition of the sealing boot, in particular:

Check if the retainer ring, which secures the sealing boot at the conical section of the ball stud, is still present.

Check if grease is present on the external surface of the sealing boots. Escaped fluid and accumulations of grease on the sealing boot may be the result of the sealing boot's rupturing. In this case, the ball joint must be systematically replaced.

#### 3.3.2 Play Measurement

1. Raise the vehicle and support through axle jacking points.
2. Using a caliper, measure dimension A on figure 20.
3. With a lever tool, exert sufficient force under the upper A-arm as to separate the upper A-arm from the upright in order to have the ball joint to its maximum extent. Remeasure dimension A. If the difference between the two dimensions is greater than 0.060" (1.5mm), then the ball joint should be replaced.

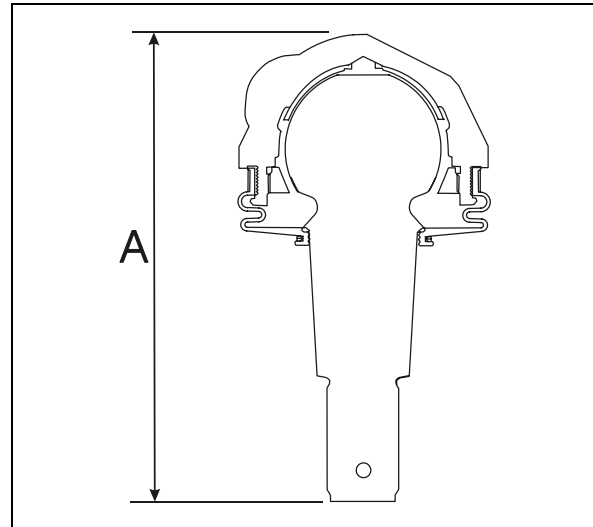

FIGURE 20: UPPER A-ARM CENTRAL BALL JOINT 16116

## 4. FRONT END ALIGNMENT

Proper front end alignment must be maintained to insure ease of steering and provide satisfactory tire life. When making front end alignment inspections, the vehicle must be level and empty with the full weight of the vehicle on the wheels.

Front end alignment inspections fall into two groups: regular service inspections performed at periodic intervals, and inspections to determine the extent of damage after a collision or severe service.

Regular service inspections concern toe-in, camber and caster.

Any variation from the specified alignment will indicate either a need for adjustment or a more thorough inspection to determine if parts replacement is required.



### WARNING

During alignment, both camber and caster among other angles are adjusted. When adjusting these we install or remove shims from the lower "A" arms of the ISS suspension. After performing alignment, make sure that the following is done:

- Installing a new lock nut after all shims are finalized.
- Torque replaced nuts as per figure 24.
- Installing a longer bolt if less the 2 threads are remaining after the nut.
- Using a Torque mark on the nut for future visual inspection.

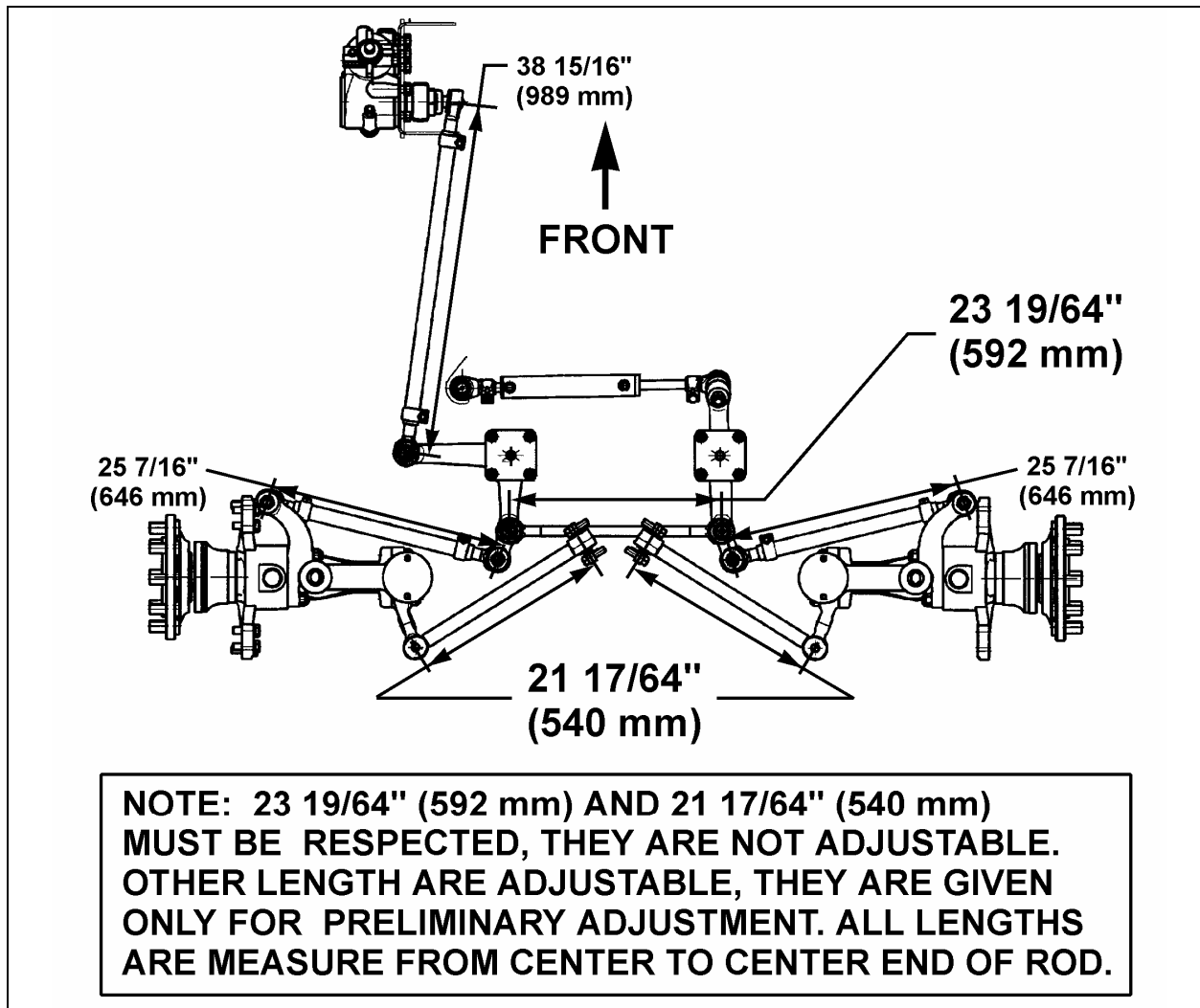

FIGURE 21: STEERING LINKAGE MEASURE

16132

## 4.1 ALIGNMENT TERMINOLOGY

**Wheel Camber**

The amount the wheels are inclined from the vertical plane (A, Fig. 22).

**Wheel Toe-In**

The distance the front wheels are closer together at the front than at the rear of the tires (D minus E, Fig. 22).

**King Pin Inclination**

The inclination of the king pin from vertical toward the center of the vehicle at the top and outward at the bottom (B, Fig. 22).

**Front Axle Caster**

The inclination of the king pin from vertical in the fore and aft direction (C, Fig. 22).

## 4.2 FRONT END INSPECTION

Before checking front end alignment, make the following inspection:

1. Check that the vehicle is at normal ride height (see paragraph "9. Suspension Height Adjustment").
2. Check the tires for proper inflation.
3. Check wheel installation and run-out.
4. Check wheel bearing adjustment.
5. Check tie rods and drag link ends for looseness.
6. Check king pins for looseness.
7. Check if the length of the torque rods is 21 17/64" (540 mm) (Fig. 21). Check if the length of the relay rod is 23 19/64" (592 mm).



### 4.3 FRONT WHEEL CAMBER

Positive camber is the outward inclination of the wheels at the top, negative or reverse camber is the inward inclination of the wheels at the top. Camber variations may be caused by wear at the wheel bearings, wheel spindle bushings, or bent suspension parts.

Check camber, with an accurate gauge. If camber is incorrect, check suspension parts for wear and replace worn parts. If wear is not perceptible, suspension parts may be bent or lower suspension arm may be improperly shimmed.

Check King pin inclination. If King pin inclination is incorrect, readjust the camber and check king pin inclination again.

**NOTE**

*Camber is more important than king pin inclination, so adjust camber and verify king pin inclination.*

Shim the lower suspension arm to adjust camber. If the king pin inclination is incorrect, the wheel king pin assembly may be bent and therefore should be replaced.

Excessive positive camber results in irregular wear of the tires at the outer shoulders. Negative or reverse camber causes wear at the inner shoulders.

**NOTE**

*Shim only the lower suspension arm to adjust the front wheel camber.*



**CAUTION**

Once the perfect shim combination is achieved, always install new stover nuts because the self locking effect is lost after tightening and loosening of the nut. It is recommended to punch marks to detect loosening of the nuts during future visual inspections.

### 4.4 FRONT WHEEL TOE-IN

Toe-in is measured from the center of the tire treads. Measurements at the front and rear of the tires must be made at the same height from the floor. Incorrect toe-in results in excessive tire wear and steering instability with a tendency to wander.

#### 4.4.1 Toe-In Check

1. Check the camber adjustment and adjust if necessary.
2. Hoist the front of the vehicle and spin the wheels marking the centerline of the tire treads.
3. Place the wheels in the straight ahead position and lower the vehicle to rest on the floor.
4. Roll the vehicle ahead several feet. This removes any slack caused by looseness in the wheel bearings or steering connections.
5. Check the distance between the tire centerlines at the front and rear of the front tires. These two measurements must be made at the same height above the floor. The front measurement must be  $3/32 \pm 1/32$  of an inch less than the rear measurement.

#### 4.4.2 Toe-In Adjustment

1. Loosen the tie rod clamp bolts.
2. Using a pipe wrench, turn the tie rod tubes to obtain the toe-in measurement specified in step 5 under paragraph "4.4.1 Toe-in Check" of this Section.
3. Tighten the tie rod clamp bolts and recheck toe-in.
4. Check that the angular relationship of the pitman arm to the steering gear is as shown in figure 9.

**NOTE**

*Use only tie rods to adjust toe-in.*

### 4.5 FRONT AXLE CASTER

Positive caster is the inclination of the top of the king pins toward the rear of the vehicle. Negative or reverse caster is the inclination of the king pins toward the front of the vehicle. This vehicle is designed with positive caster. The purpose of caster is to provide steering stability by keeping the wheels in a straight ahead position.

Caster variations may be caused by bent upper suspension arm, lower suspension arm, or king pin housing. Caster should be adjusted with shims. Precision instruments should be used to measure caster. Shim bell crank and idler arm to adjust caster.

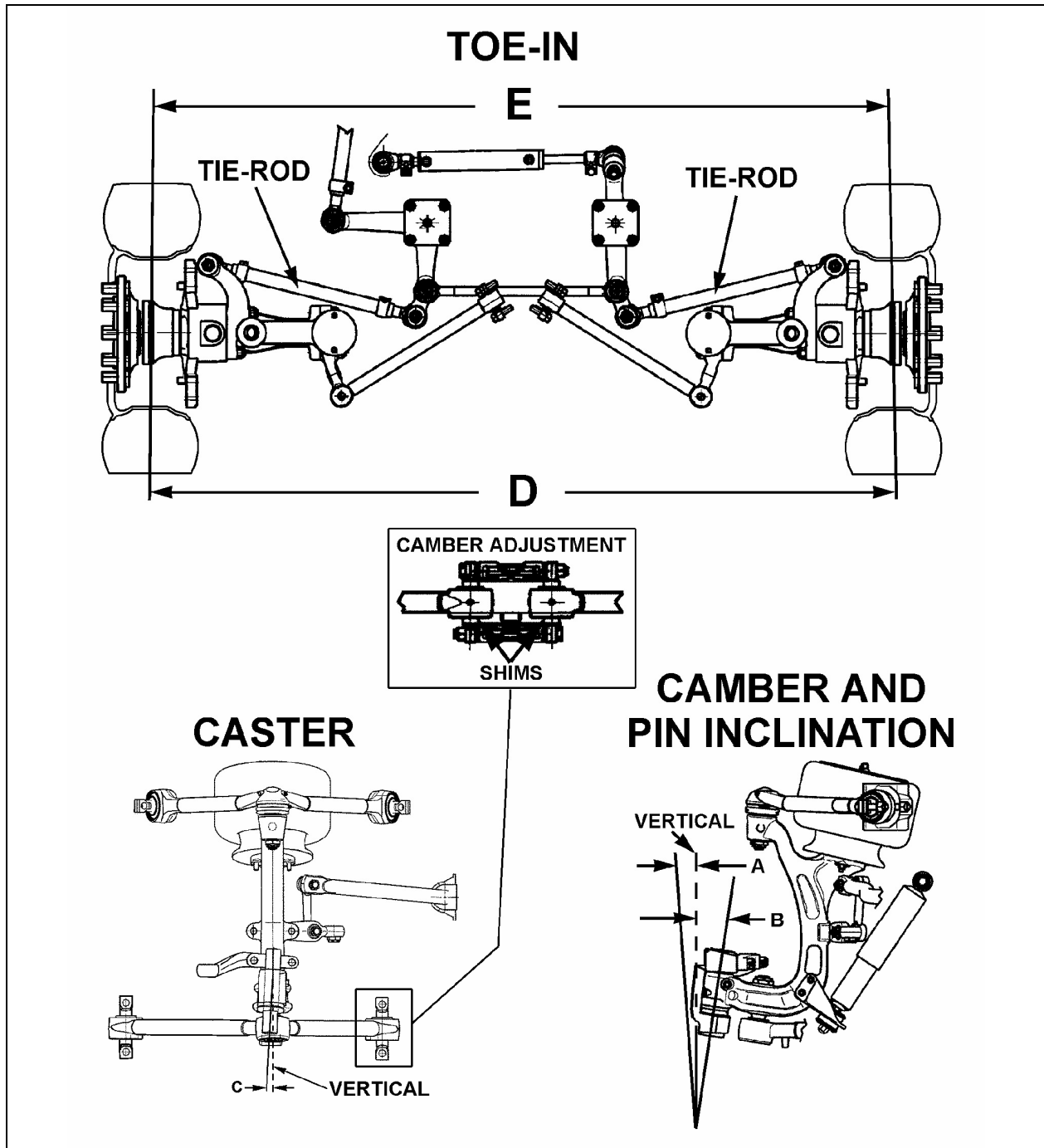

FIGURE 22: FRONT END ALIGNMENT DIAGRAM

16133

ALIGNMENT SPECS (See Figure 22)								
Load		Minimal		Nominal		Maximal		
		Non-converted	Converted	Non-converted	Converted	Non-converted	Converted	
A	WHEEL CAMBER	0.2	-0.150	0.35	0.0	0.55	0.200	
B	KING PIN INCLINATION	8° (not adjustable)						
C	CASTER		2.55		2.8		3.05	
D-E	TOE-IN		0.08		0.10		0.12	

Variations from the specified caster will affect steering stability, cause wandering, wheel shimmy, and reduce returnability when pulling out of curves.

#### 4.6 MAJOR DAMAGE

If the suspension has sustained major damage, it may be necessary to shim the bell crank and the idler arm to avoid the bump steer or roll steer. Moreover refer to paragraph "4. Front End Alignment".

### 5. FRONT AIR SPRINGS

Two "rolling lobe" type air springs are used with the independent front suspension, one at each wheel. These air springs are special and use the complete piston as an extra reservoir to lower the spring stiffness. Front air springs are attached to the subframe and to uprights.

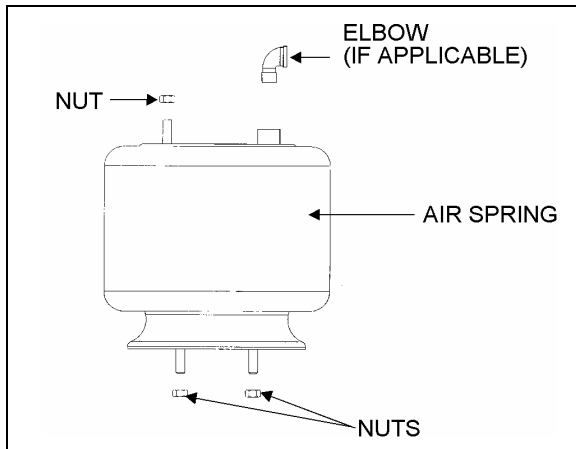

FIGURE 23: AIR SPRINGS

16052

#### 5.1 INSPECTION

1. Check operation of bellows.
2. Visually inspect bellows for evidence of cracks, punctures, deterioration, or chafing. Replace the bellows if damage is evident.
3. With the primary air system at normal operating pressure (95 - 125 psi (655 - 860 kPa)), coat all suspension air line connections and bellow mounting areas with a water and soap solution. Bubbles will indicate an air leak, and none is permissible. Repair or replace defective parts.

#### **NOTE**

If air spring is removed from vehicle, bellows can be lightly inflated and submerged in water to detect any leakage. If leakage is detected, replace bellows.



### WARNING

To prevent personal injury, do not apply more than 10 psi (69 kPa) air pressure to the unmounted air spring.

#### 5.2 REMOVAL

#### **NOTE**

Front air springs can be removed without removing the entire suspension assembly.

1. Safely support vehicle at the recommended body jacking points and jack up body understructure.
2. To gain access to a given air spring, the corresponding wheel can be removed.



### CAUTION

Only the recommended jacking points must be used as outlined in Section 18, "Body" in the maintenance manual.

3. Support the assembly with a suitable jack.
4. Exhaust compressed air from accessory air tank by opening drain cock under reservoir.
5. Disconnect the height control valve link and pull down the overtravel lever to ensure all air is exhausted from air springs.

#### **NOTE**

While performing this step, do not change the height control valve overtravel lever adjustment.

6. Disconnect air line from air spring, remove elbow (if applicable), and cover both the line end and fitting to prevent the entry of foreign matter.
7. Remove the air spring upper nut, and then the two lower nuts. Remove air spring and remove the back up plate from the top of the air spring.

#### 5.3 INSTALLATION

#### **NOTE**

To facilitate air spring installation, compress it manually then put a piece of tape over the air line threaded fitting. This prevents air from getting back into the bag and keeps it compressed, thus enabling to place the bag in between the mounting plates and greatly easing installation.

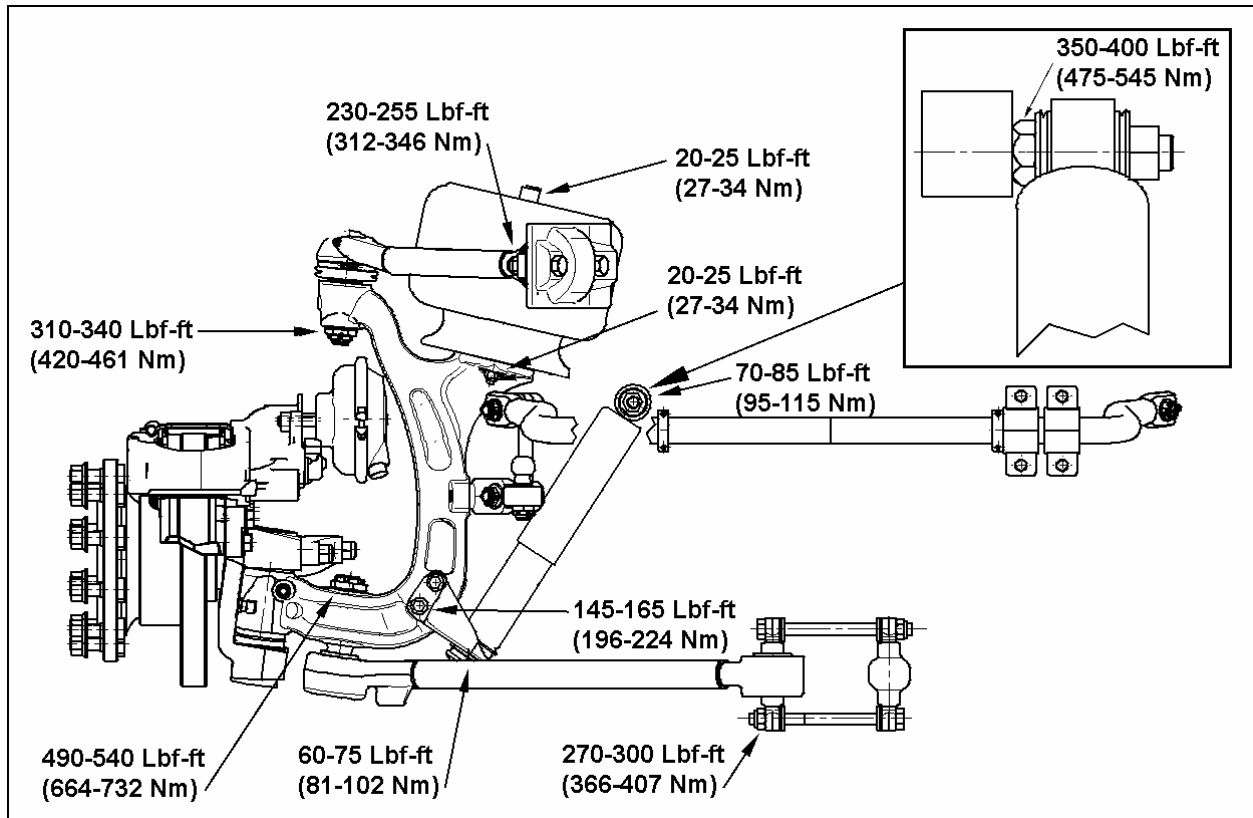

FIGURE 24: AIR SPRING AND SHOCK ABSORBER

16180

1. Compress air spring as necessary, then aligning studs with their holes, position air spring between both the lower and upper supports. Thread the lower nuts and the small upper nut a few turns.
2. Tighten and torque the lower stud nuts, and then the upper nut to 20-25 lbf-ft (27-34 Nm).
3. Install elbow (if applicable), then connect air line.
4. Connect the height control valve link.
5. Build up air pressure in system.

**NOTE**

*To accelerate this operation, air reservoirs can be filled from an exterior air supply connected to the accessory tank fill valve or to the emergency fill valve.*

6. Check operation of bellows, and with the primary air system at normal operating pressure (95 - 125 psi (655 - 860 kPa)), coat the air line connections and air spring mounting areas with a water and soap solution. Bubbles will indicate an air leak,

and none is permissible. Repair or replace defective parts.

7. Remove the hydraulic floor jack from underneath shock absorber bracket.

**6. SHOCK ABSORBERS**

The two front shock absorbers are double-acting and telescopic type. Shock absorbers ensure a smooth ride and enhance vehicle stability on the road. Front shock absorbers have eye-type mountings on the upper side and bayonet type on lower side. Shock absorbers are non-adjustable and non-repairable.



**CAUTION**

When a shock absorber is found defective, always replace with a new set on affected axle, except if there has been a recent replacement of one unit. The following method will help in determining if both shock absorbers on the same axle have to be replaced.

### 6.1 SHOCK ABSORBER REMOVAL

1. Remove the nut, washer and rubber joint from shock absorber mounting stud. Discard the rubber joints.
2. Remove the nut and washer from shock absorber mounting pin (upper side), taking care to identify the inner and outer washers to ease reinstallation. Refer to figure 25 for details.
3. Remove the shock absorber from the vehicle.
4. Remove inner: washers, rubber joint and bushings from the shock absorber. Discard bushings and rubber joint.

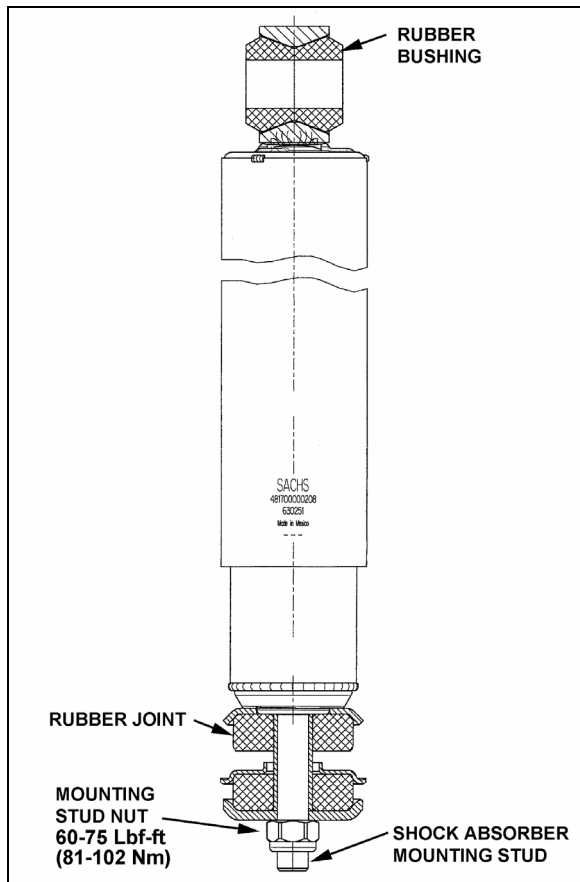

FIGURE 25: SHOCK ABSORBER

16181

### 6.2 SHOCK ABSORBER INSTALLATION

1. Check that the shock absorber mounting pin torque is proper (350-400 lbf-ft (475-545 Nm)). Ensure that the stud is clean and not stripped (upper side).
2. Install new rubber (mounting) bushing on shock absorber (upper side).

3. Place the inner washer on shock absorber pin (Fig. 25).
4. Install washer and rubber joint on shock absorber mounting stud (lower side).
5. Install the shock absorber as shown in figure 24 with the mounting stud protruding through the hole in the mounting bracket and the shock absorber eyes over the mounting pins. Install the outer washer.
6. Place a rubber joint and washer on the shock absorber mounting stud. Place the lower shock absorber mounting stud nut and torque to 60-75 lbf-ft (81-102 Nm).
7. Place the upper mounting pin stud nut and torque to 70-85 lbf-ft (95-116 Nm).

### 7. SWAY BAR

A sway bar is provided on the front and rear suspensions to increase vehicle stability. It controls lateral motion (swaying movement) of vehicle.

#### 7.1 REMOVAL

1. Disconnect the two links from sway bar.
2. Safely support the sway bar. Unbolt bushing collars from subframe.
3. Remove sway bar.

#### **NOTE**

*Sway bar bushings are slit to ease their removal.*

#### 7.2 INSTALLATION

1. Loosely install the sway bar.
2. Torque bushing collar nuts to 80-100 lbf-ft dry (110-135 Nm).
3. Torque sway bar link upper nuts to 165-200 lbf-ft dry (225-270 Nm) on front suspension and to 100-120 lbf-ft dry (135-163 Nm) on rear suspension.
4. Torque sway bar link lower nuts to 165-200 lbf-ft dry (225-270 Nm) on front suspension and to 70-80 lbf-ft dry (95-110 Nm) on rear suspension.

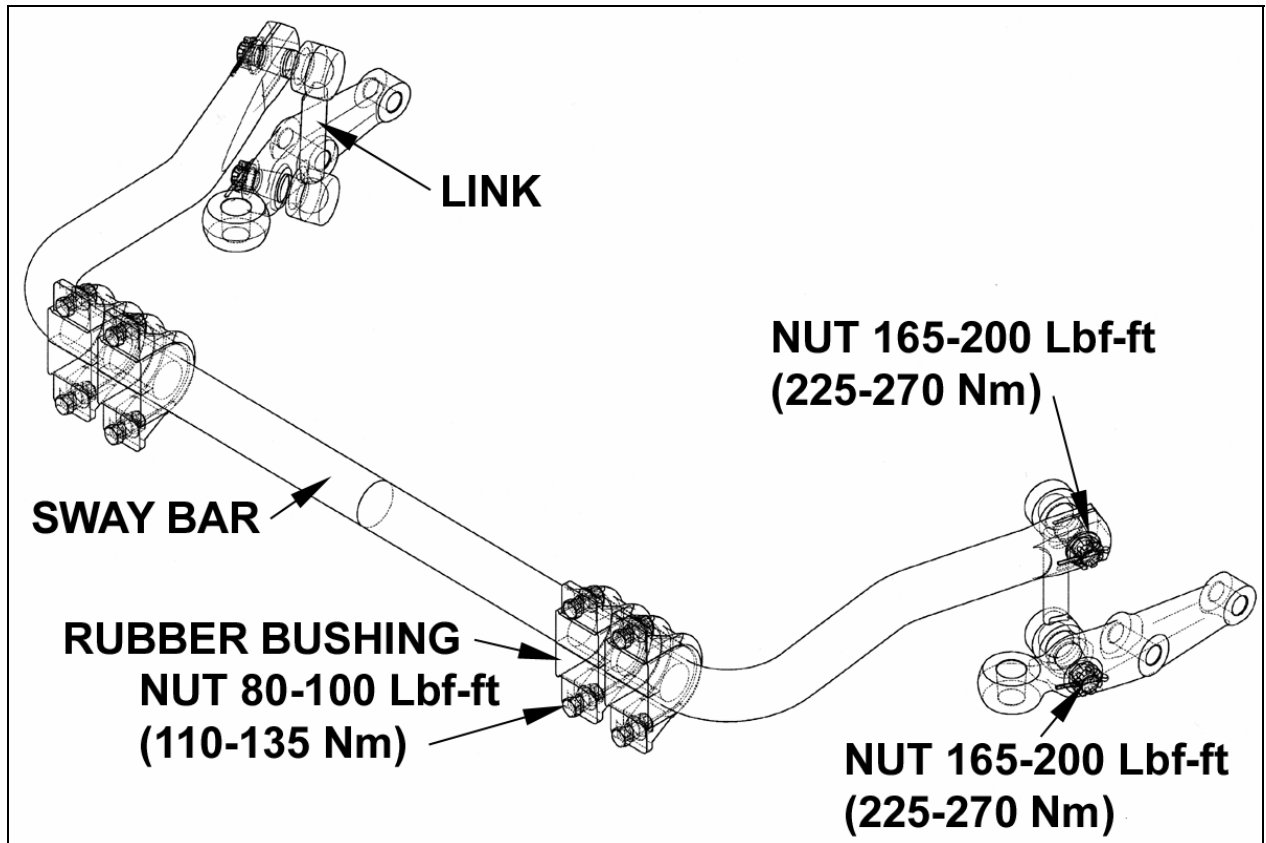

FIGURE 26: SWAY BAR (FRONT SUSPENSION)

16138D

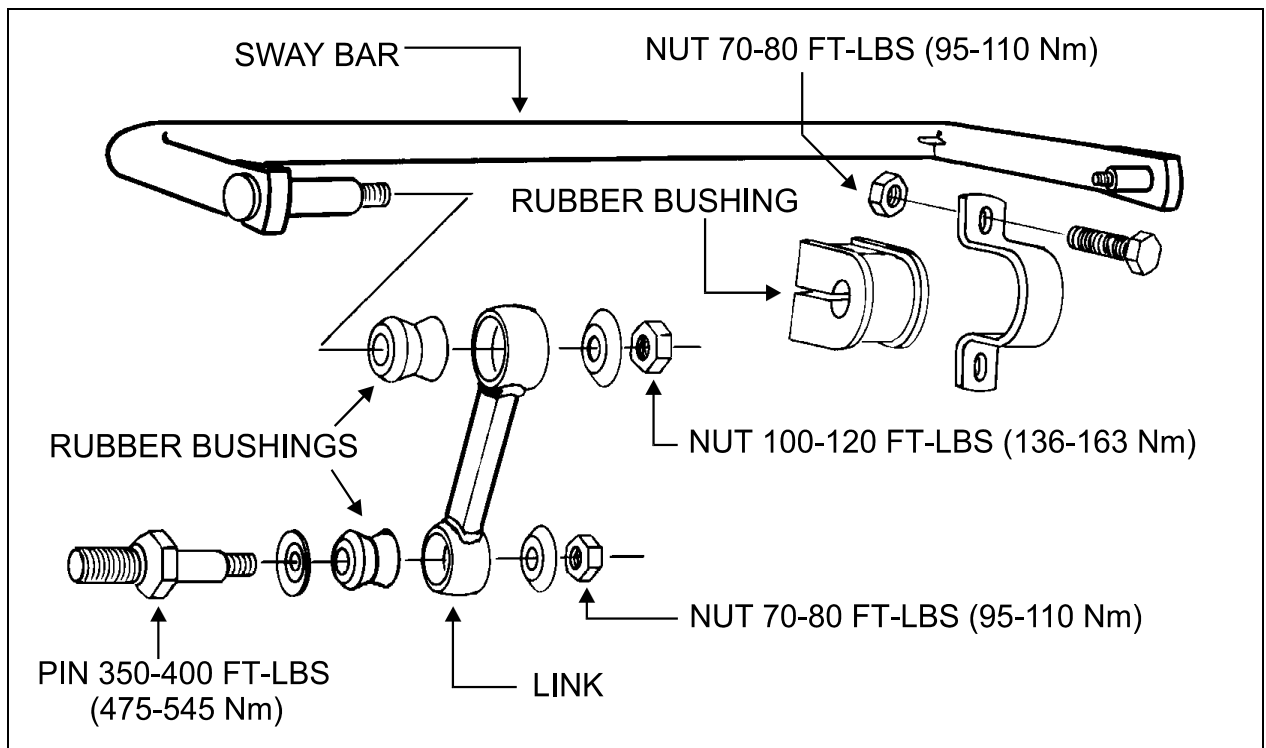

FIGURE 27: SWAY BAR (REAR SUSPENSION)

16014

### 8. REAR SUSPENSION

For a description of all these systems, refer to the appropriate heading in this section.

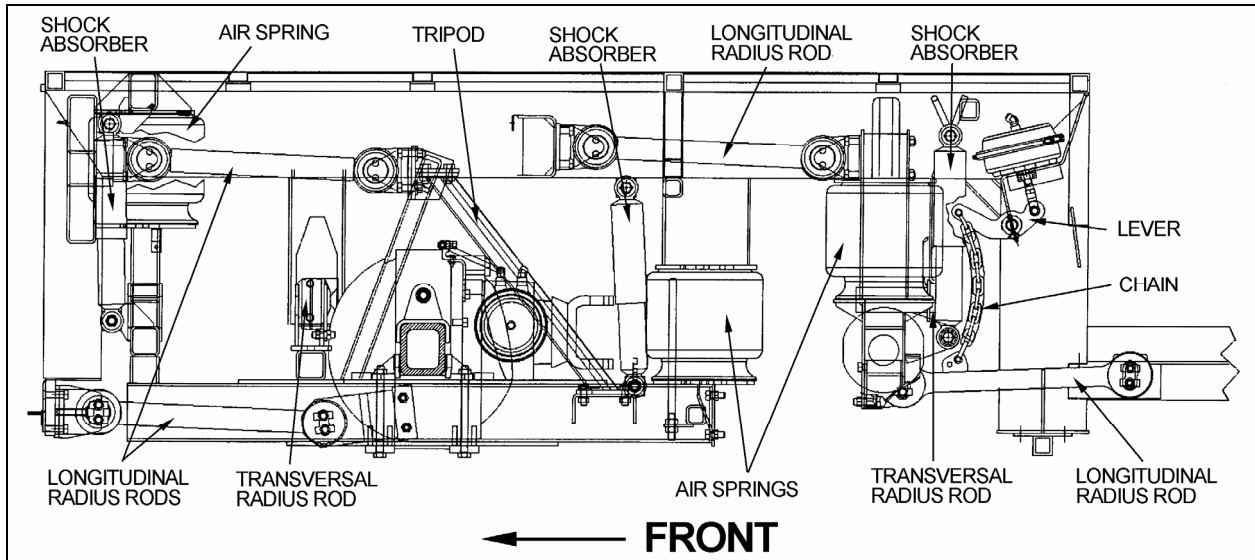

FIGURE 28: REAR SUSPENSION COMPONENTS

16140

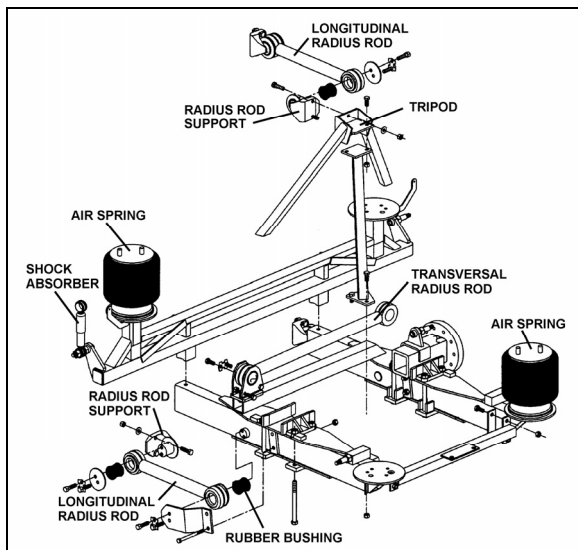

FIGURE 29: DETAILS OF REAR SUSPENSION

16106

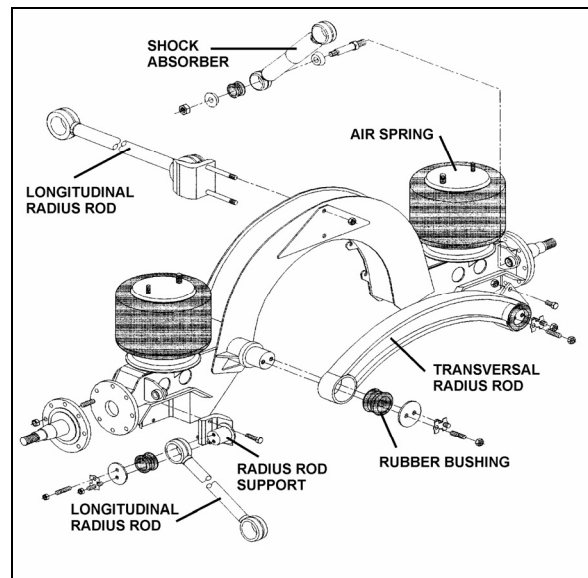

FIGURE 30: TAG AXLE SUSPENSION

16107

## Section 16: SUSPENSION

### 8.1 AIR SPRINGS

The air springs are made from a special compound rubber molded to the proper contour and dimensions. The entire vertical load of the vehicle is supported by these springs. Each of the two axles is provided with air springs that are attached to the subframe and to the axles (Fig. 31).

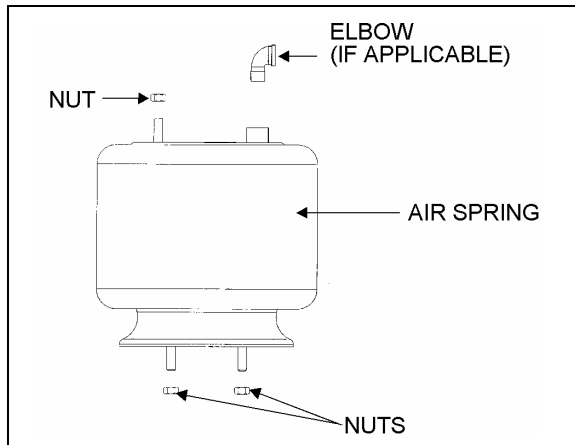

FIGURE 31: AIR SPRING

16052

#### 8.1.1 Inspection

1. Check operation of bellows.
2. Visually inspect bellows for evidence of cracks, punctures, deterioration, or chafing. Replace the bellows if any damage is evident.
3. With the primary air system at normal operating pressure (95 - 125 psi (655 - 860 kPa)), coat all suspension air line connections and bellows mounting areas with a water and soap solution. Bubbles will indicate an air leak, and none is permissible. Repair or replace defective parts.

#### NOTE

*If air spring is removed from vehicle, bellows can be lightly inflated and submerged in water to detect any leakage. If any leakage is detected, replace bellows.*



#### WARNING

To prevent personal injury, do not apply more than 10 psi (69 kPa) of air pressure to the uninstalled air spring.

#### 8.1.2 Removal

#### NOTE

*Suspension air springs (drive and tag axles) can be removed without removing the entire axle assembly.*

1. Safely support vehicle at the recommended body jacking points. To gain access to a given air spring, the corresponding wheel can be removed as follows.
  - a) Jack vehicle until the tire clears the ground, and place safety supports underneath body.



#### CAUTION

Only the recommended jacking points must be used as outlined in Section 18, "Body".

- b) Support the axle with a suitable hydraulic floor jack at the recommended jacking point.
  - c) Remove wheel.
2. Exhaust compressed air from accessory air tank by opening drain cock under reservoir.
  3. Disconnect the height control valve link and pull down the overtravel lever to ensure all air is exhausted from air springs.

#### NOTE

*While performing this step, do not change the height control valve overtravel lever adjustment.*

4. Disconnect air line from air spring, remove elbow (if applicable), and cover both the line end and fitting to prevent the entry of foreign matter.
5. Remove the air spring upper nut, and then the two lower nuts. Remove air spring.

#### 8.1.3 Installation

1. Compress air spring as necessary, then aligning studs with their holes, position air spring between both the lower and upper supports. Thread the lower nuts and the small upper nut a few turns.



**NOTE**

*To facilitate air spring installation, compress it manually then put a piece of tape over the air line threaded fitting. This prevents air from getting back into the bag and keeps it compressed, thus enabling to place the bag in between the mounting plates and greatly easing installation.*

2. Tighten and torque the lower stud nuts, and then the upper one to 20 – 25 lbf-ft (27 – 34 Nm).
3. Thread the remaining upper nut (large nut) and tighten to 20 – 25 lbf-ft (27 – 34 Nm).
4. Install elbow (if applicable), then connect air line.
5. Connect the height control valve link.
6. Build up air pressure in system.

**NOTE**

*To accelerate this operation, air reservoirs can be filled from an exterior air supply connected to the accessory tank fill valve or to the emergency fill valve.*

7. Check operation of bellows, and with the primary air system at normal operating pressure (95 – 125 psi (655 – 860 kPa)), coat the air line connections and air spring mounting areas with a water and soap solution. Bubbles will indicate an air leak, and none is permissible. Repair or replace defective parts.
8. Reinstall wheel.
9. Remove the hydraulic floor jack from under the axle, then lower vehicle to ground.

## 8.2 SHOCK ABSORBERS

Double-action, telescoping-type shock absorbers ensure a smooth ride and enhance vehicle stability on the road. All shock absorbers are eye-type mountings. The tag axle is provided with two shock absorbers while the drive axle is provided with four of them (Fig. 28, 29 and 30).

Shock absorbers are non-adjustable and non-repairable. Maintenance requirements involve replacement of the rubber mounting bushings, and tightening of all shock absorber pins at the proper torque of 500 - 550 lbf-ft (680 - 750 Nm) when shock absorber replacement occurs. If a shock absorber becomes inoperative, complete unit must be replaced.

**CAUTION**

When a shock absorber is found defective, always replace with a new set on affected axle, except if there has been a recent replacement of one unit. The following method will help in determining if both shock absorbers on the same axle have to be replaced.

### 8.2.1 Inspection

Loosen lower mounting of both shocks, and then carefully attempt to raise and lower the bottom portion of each shock. Note the rate of effort for distance of travel. Replace both shocks if a definite differential rate is found.

The shock must be bench checked in an upright, vertical position. If checked in any other position, air will enter the cylinder tube and make the shock absorber appear defective.

Proceed as follows to check shock absorbers:

1. With the shock absorber in a vertical position (top end up), clamp the bottom mount in a vise.

**CAUTION**

Do not clamp the reservoir tube or the dust tube.

2. Rotate the dust tube. Notice any binding condition (may be compared with new unit). Binding condition indicates a scored rod. Units with scored rods should be replaced.
3. Fully extend shocks and check for leaks in the seal cover area. Shock fluid is a very thin hydraulic fluid that has a characteristic odor and dark brown tint. A slight trace of shock fluid around the seal cover area is not a cause for replacement. The shock seal is designed to permit a very slight seepage to lubricate the rod. Units that leak should be replaced.
4. Visually check shock for dents that could cause the shock to bind. Also, check for a bent rod.
5. Extend and collapse shock several times to determine that it has control (resistance) in both rebound and compression.
6. Visually inspect the shock mountings and vehicle mounting for:

## Section 16: SUSPENSION

- Broken mounts;
- Extreme bushing wear;
- Shifted bushing or sleeve;
- Deep cracks in bushing material (shallow surface cracks are normal);
- Loose shock absorber pins;
- Presence of convex washers, and their position relative to the rubber bushing.

### 8.2.2 Removal

- Remove nuts and washers from shock absorbers on upper and lower mounting pins, taking care to identify the inner and outer washers to ease reinstallation. Refer to figure 32 for details.
- Remove the shock absorber assembly from pins.
- Remove the two inner bushings from the shock absorber and discard them.

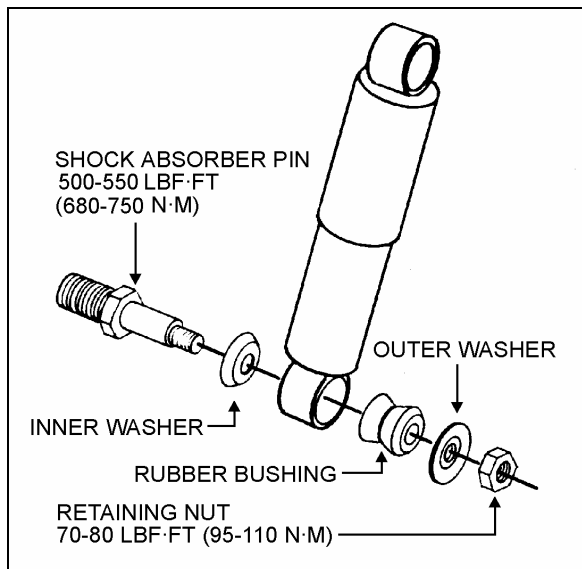

FIGURE 32: SHOCK ABSORBER

16008

### 8.2.3 Installation

- Ensure that the shock absorber mounting pins are tight and that the threads are not stripped.
- Install new rubber mounting bushings on shock absorbers (upper and lower).
- Place the inner washers (with washer convex side facing the shock absorber rubber bushing) on each shock absorber pin (Fig. 33).

- Install the shock absorber eyes over the mounting pins, then the outer washers (with washer convex side facing the shock absorber rubber bushing) on each shock extremity.

#### NOTE

If shock absorber pins are removed, they must be reinstalled using "loctite" (see "Parts Specifications" in this section).

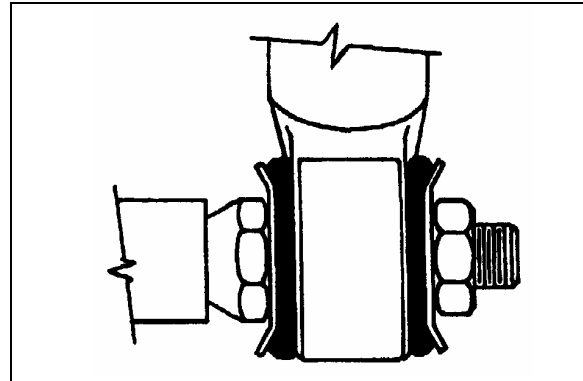

FIGURE 33: TYPICAL SHOCK ABSORBER SETUP 16009

- Place the lower and upper mounting pin stud nuts and torque to 70 - 80 lbf-ft (95 - 110 Nm).

### 8.3 RADIUS RODS

Radius rods are used to secure the axles in the proper transversal and longitudinal positions. Four radius rods are provided on the drive axle suspension (three longitudinal and one transversal) and also four on the tag axle with a layout similar to the drive axle. Refer to figures 28, 29 and 30 for details. These rods transmit both braking and driving forces from the axles to the vehicle body.

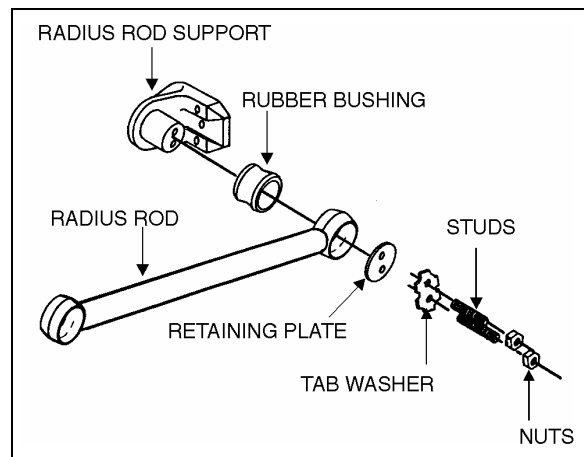

FIGURE 34: TYPICAL RADIUS ROD SETUP

16010

## 8.3.1 Inspection

The following instructions apply to all radius rods used on this vehicle:

1. Clean all parts thoroughly.
2. Inspect radius rods for distortion and cracks. We recommend the "Magnaflux" process to detect cracks in the radius rod. Any damaged part should be replaced with a new one.

**NOTE**

*New bushings should be used when rods are replaced.*

3. The radius rod bushings should be checked periodically for signs of shearing, deterioration, or damage. Any defective part should be replaced with a new one.

## 8.3.2 Removal

1. Flatten the tab washer which secures the two retaining nuts (or bolts), then unscrew the nuts (or bolts) at each extremity of the radius rod (Fig. 34).
2. Remove the tab washer and the retaining plates and radius rod ends from anchor pins, and then remove the radius rod.

## 8.3.3 Bushing removal

1. Safely support the radius rod as shown in figure 35.

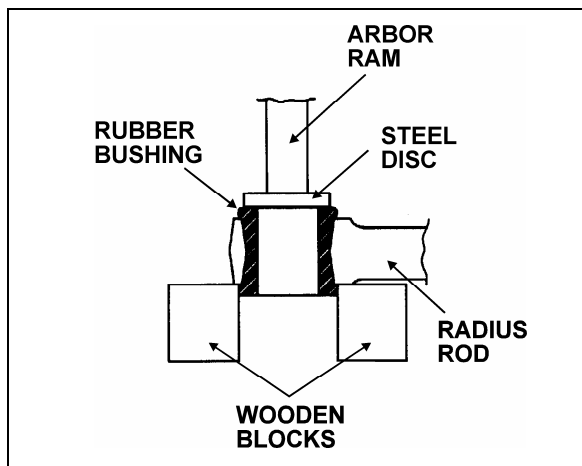

FIGURE 35: RADIUS ROD BUSHING REMOVAL 16011

2. Place a flat steel disc, slightly smaller than the outside diameter of the bushing (Fig. 35).

3. Using an arbor press or a suitable driving tool, press or drive the old bushing out of the rod and discard the bushing.

**CAUTION**

Make sure to prevent the steel disc from contacting the radius rod end.

## 8.3.4 Bushing installation

1. Lightly spray the inner and outer surfaces of radius rod bushing with water.

**CAUTION**

No lubricant whatsoever is to be used on the rubber bushing.

2. Safely support the radius rod, and place new bushing on top of the radius rod end (Fig. 36).
3. Place a block of wood on top of bushing and press on it manually.
4. If necessary, use an arbor press or a suitable driving tool. Press or drive the bushing into the radius rod end until it extends equally on both sides of the rod.
5. It is also possible to proceed differently. Place radius rod bushing on a plane surface. Spray a light coat of water on the inner and outer surfaces of radius rod bushing.
6. Take radius rod, align the bushing. Tap radius rod on bushing until latter is positioned correctly.

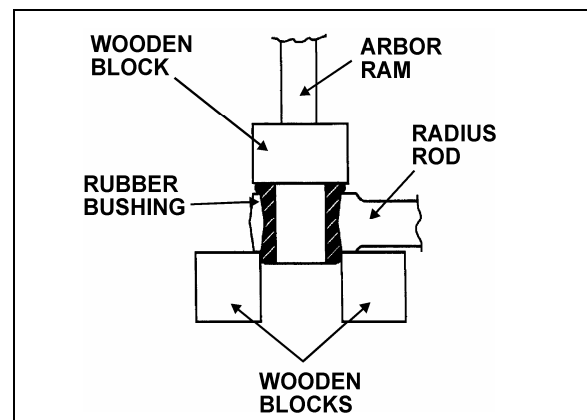

FIGURE 36: RADIUS ROD BUSHING INSTALLATION 16012

## Section 16: SUSPENSION

### 8.3.5 Installation

1. Lightly spray the radius rod support with water. Place the radius rod end over the radius rod support (Fig. 36).
2. Position the retaining plate. Install the tab washer and nuts (or bolts).

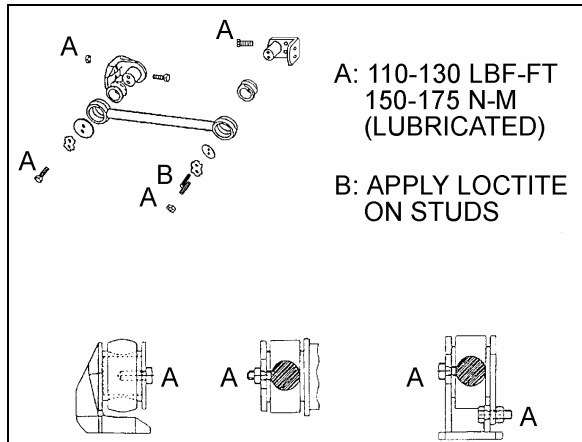

FIGURE 37: RADIUS ROD INSTALLATION 16028



### CAUTION

Always use new tab washers at installation.

3. Tighten the nuts (or bolts) lightly, and repeat at the other end.
4. Refer to heading "*Suspension Height Adjustment*" later in this section, and set the vehicle to normal ride height.
5. With the vehicle at normal ride height, apply oil on threads and tighten all radius rod anchor pin nuts or bolts to 110 – 130 lbf-ft (150 – 175 Nm).



### CAUTION

It is extremely important upon reconnection of the rods that the proper clearance height between the axle and body be maintained. Otherwise, the rubber bushings in radius rod ends will become preloaded, thus reducing their life span.

## 9. SUSPENSION HEIGHT ADJUSTMENT

The flow of pressurized air from the accessory air tank to the air springs is controlled by three height control valves. The two rear valves are mounted to the subframe, one on each inner side of rear wheelhousing and connected to the rear axles through an arm and link connection.

The front valve is mounted to the subframe **at center of front sway bar** and connected to the front air tank support (Fig. 38). The front height control valve regulates air to front suspension air springs in order to maintain the vehicle at the required height. These connections allow the valves to apportion air pressure in the springs to the vehicle load, maintaining normal ride height.

Immediate response height control valves increase or decrease the air pressure in the suspension system as required.

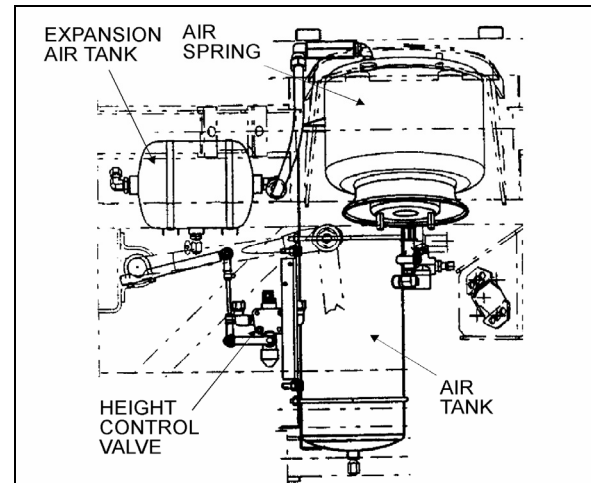

FIGURE 38: HEIGHT CONTROL VALVE LOCATION 16057

The appropriate vehicle body height is obtained by measuring the clearance of all the air springs installed on the vehicle. The two front air springs clearance should be  $11 \pm \frac{1}{4}$ " (279  $\pm$  6 mm). Refer to figure 39 to identify the correct area to take measurement. The rear air springs clearance should be  $11 \frac{1}{2} \pm \frac{1}{4}$ " (292  $\pm$  6 mm).

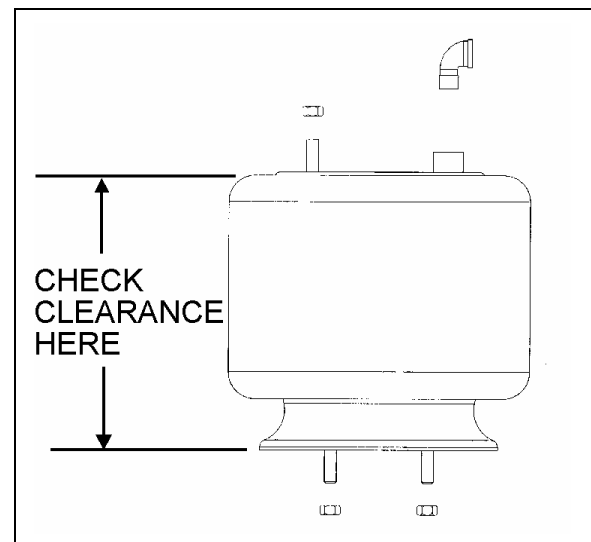

FIGURE 39: TYPICAL AIR SPRING CLEARANCE 16058

At this point, it should not be necessary to make an adjustment under normal service conditions. However, if an adjustment is required, change the position of the overtravel lever in relation to the overtravel control body. The lever should be moved up to raise vehicle height, and down to lower it. Check that main air pressure is at normal operating pressure and raise the vehicle to the specified height.



## CAUTION

Always adjust on "fill cycle". If it is necessary to lower vehicle height, release sufficient air to be well below height, and adjust to height or fill cycle.

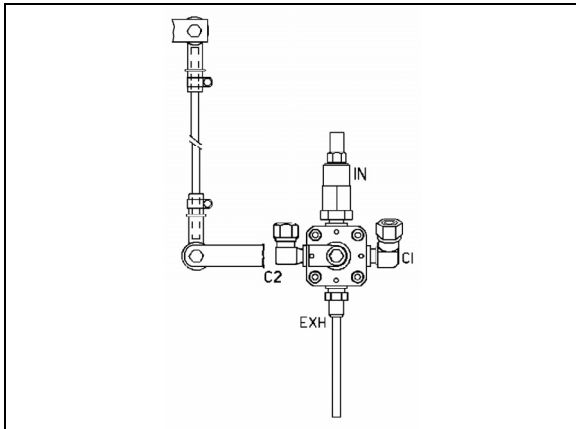

FIGURE 40: FRONT HEIGHT CONTROL VALVE 16100

The normal ride height is obtained by adjusting air spring clearance of both front and rear suspension as follows:

### Front air spring clearance

1. With the vehicle at normal operating air pressure (100 - 125 psi (689 - 860 kPa)), measure air spring clearance. This clearance should be  $11 \pm \frac{1}{4}$ " (279  $\pm$  6 mm).

#### NOTE

The measurement should be taken from underneath the upper air spring support on subframe to top of the lower air spring support on axle (refer to figure 39 for more details). If adjustment is required, begin with the drive axle.

2. Loosen the clamp on the height control valve rubber coupling and bring it up or down (Fig. 40).

#### NOTE

Allow suspension to stabilize before taking reading.

When the desired height is obtained, tighten clamp.

### Rear air springs clearance

1. With the vehicle at normal operating air pressure [100 - 125 psi (689 - 860 kPa)], measure air spring clearance. This clearance should be  $11 \frac{1}{2} \pm \frac{1}{4}$ " (292  $\pm$  6 mm).

#### NOTE

The measurement should be taken from underneath the upper air spring support on subframe to top of the lower air spring support on axle (refer to figure 39 for more details).

2. Loosen the clamp on the height control valve rubber coupling and bring it up or down (Fig. 41).

#### NOTE

Allow suspension to stabilize before taking reading.

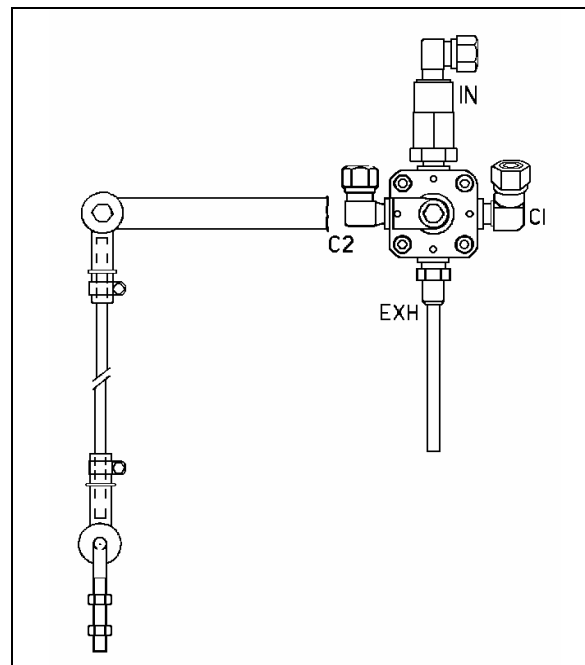

FIGURE 41: REAR HEIGHT CONTROL VALVE 16093

When the desired height is obtained, tighten clamp.

## 10. HEIGHT CONTROL VALVE

The height control valves automatically add air to, or release air from air springs to maintain constant suspension height regardless of load, or load distribution. Each valve adjusts independently according to the following conditions:

### 10.1 LOADING POSITION

As the load increases and lowers the vehicle body, the overtravel lever commands the height control valve to add air to air springs.

### 10.2 NEUTRAL POSITION

When vehicle body reaches the normal ride height, the height control valve overtravel lever reaches the "neutral" position and keeps both the supply and exhaust ports closed to ensure normal ride height is maintained. This condition remains static until the vehicle load is altered.

### 10.3 UNLOADING POSITION

As the load decreases and raises the vehicle body, the overtravel lever commands the height control valve to release air from air springs.

### 10.4 MAINTENANCE

The height control valve requires no periodic maintenance. Height control valve linkage operates on rubber bushings and no lubrication should be attempted at this location. Inspect the valve for loose joints, air leaks and worn bushings.

### 10.5 REMOVAL AND INSTALLATION

Before disconnecting a height control valve air line, securely support the vehicle by its jacking points on the body, and place safety supports underneath body. Refer to paragraph "16. Vehicle Jacking Points" in Section 18, "Body".

1. Exhaust air from air system by opening all air tank drain cocks. Remove height control valves.
2. Disconnect overtravel lever from link and pull down lever to exhaust remaining air from air springs.
3. Disconnect air supply and delivery lines from the height control valve. Cover line ends with tape to prevent entry of foreign matter.
4. Remove the nuts retaining the height control valve to the mounting bracket, then remove valve assembly.

Reverse removal procedure to replace height control valve. After installation, check for leakage using a soap and water solution.

## 11. "LEVEL-LOW" LEVELING SYSTEM

Bus shells are equipped with "LEVEL-LOW" leveling system. The purpose of the "LEVEL-LOW" is to adjust suspension in three separate points (front, rear right and rear left air springs) in order to level vehicle body. Three height control valves, automatically control air pressure in the three separate points (air springs) and maintains a constant vehicle height regardless of load, or load distribution. The control solenoid valve supplies air to the five way three-position air control valve, which bypasses the height control valve, and opens a passage to allow the air control and exhaust valve to release/supply air from air springs. To improve road comfort, an expansion air tank is installed in series with each air spring.

In addition to the above suspension components the system also includes: sway bar, upper and lower A-arms, rods and shock absorbers (Fig. 1).

#### **NOTE**

*Only for preliminary adjustment, refer to figure 21. Torque rod length must be fixed to 21 17/64" (540 mm) and relay rod to 23 19/64" (592 mm).*



#### **CAUTION**

Parts must be replaced by ones with the same part numbers or with equivalent parts, if replacement becomes necessary. Do not use parts of lesser quality or substitute design. Torque values must be used as specified during reassembly to assure proper retention of these parts.

The purpose of the "level-low" leveling system is to adjust suspension in three separate points (front, rear right and rear left) in order to level vehicle body. This system can be put into service when the ignition key is turned to the "ON" position, and must be used only when the parking brake is applied. The "level-low" warning light on the dashboard indicates that the selector switch is not in the "OFF" position. Level low system controls are located on L.H. side control panel.

## 11.1 PRINCIPLES OF OPERATION

## DOWN:

The (front/rear right/rear left) control solenoid valve supplies air to the (front/rear right/rear left) five-way three-position air control valve, which bypasses the (front/rear right/rear left) height control valve, and opens a passage to allow the air control and exhaust valve to release air from (front/rear right/rear left) air springs.

## UP:

The (front/rear right/rear left) control solenoid valve supplies air to the (front/rear right/rear left) five-way three-position air control valve, which bypasses the (front/rear right/rear left) height control valve, and opens a passage to allow the air control and exhaust valve to supply air to (front/rear right/rear left) air springs.

## DRIVE:

When the ignition key is turned to the "ON" position with selector knob in the "DRIVE" position, the drive control solenoid valve supplies air to all five-way three-position air control valves, each one opening a passage to allow height control valves to accomplish their function.

When the ignition key is turned to the "OFF" position and selector knob to the "DRIVE" position, the air is entrapped between air springs and five-way three-position air control valves to ensure the adjusted level will be kept.

**WARNING**

Never move vehicle with selector knob in any other position than the "DRIVE" position.

## 11.2 MAINTENANCE

Since the kneeling action is issued from both the air system and electrical system, refer to Section: 12, "Brake and Air System" and Section 06, "Electrical System".

For diagnosis and understanding of the system, refer to wiring diagrams, and to the appropriate air system schematic diagram annexed to Section 12, "Brake and Air System".

**12. AIR SYSTEM**

The basic air system consists of an air compressor, tanks, valves, filters and interconnecting lines and hoses (refer to Section 12, "Brake and Air System" for complete information). It provides a means for braking, operating controls and accessories, and suspension. An air system schematic diagram is annexed at the end of this Section for better understanding of the system.

The air coming from the air dryer is first directed to the wet air tank, then to the primary (for the primary brake system), secondary (for the secondary brake system), and accessory (for the pneumatic accessories) air tanks (Fig. 42).

In addition, an expansion air tank is installed in series with each air spring.

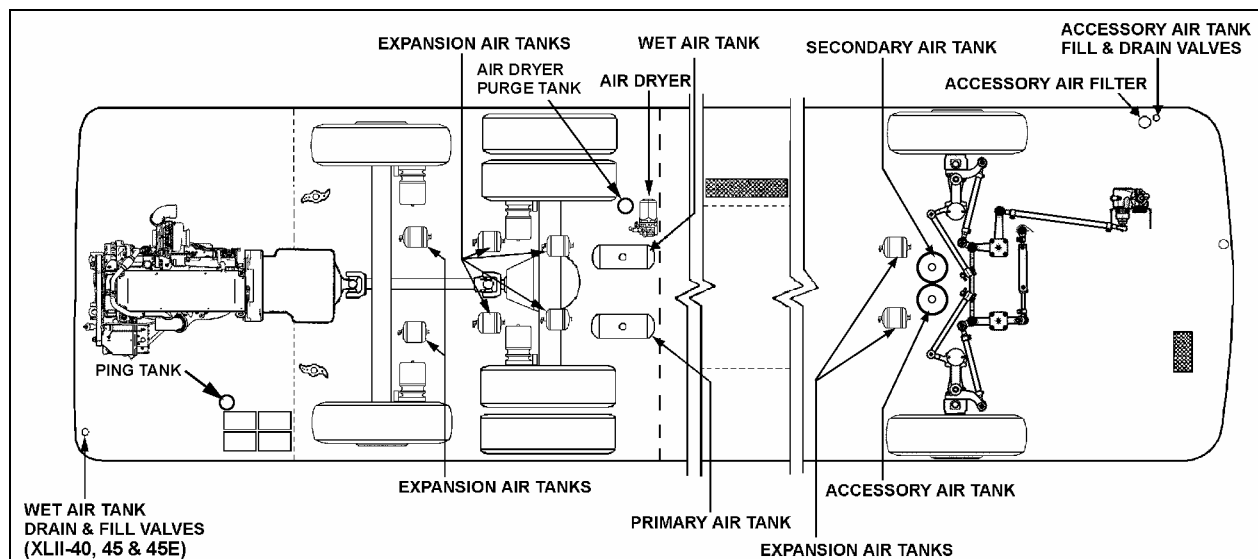

FIGURE 42: LOCATION OF AIR TANKS

24037

## Section 16: SUSPENSION

### 12.1 AIR TANK MAINTENANCE

Ensure that the accessory air tank is purged during pre-starting inspection. A good practice is to purge this tank at the end of every driving day by the remote air tank drain valve located in the steering compartment (Fig. 42).

Moreover, purge all tanks by their bottom drain valves at specified intervals.

#### 12.1.1 Wet Air Tank

This tank is installed above L.H. wheel of drive axle, and is provided with a bottom drain valve. It is recommended to **purge** the wet air tank by its bottom drain valve every 12,500 miles (20 000 km), or once a year, whichever comes first.

A remote valve located in engine compartment and accessible through engine R.H. side door is used to **drain** the air dryer (Fig. 43).

#### 12.1.2 Primary Air Tank

The primary air tank is located above R.H. wheel of drive axle.

This tank is provided with a bottom drain valve (Fig. 42). It is recommended to purge the primary air tank by its bottom drain valve every 12,500 miles (20 000 km) or once a year, whichever comes first.

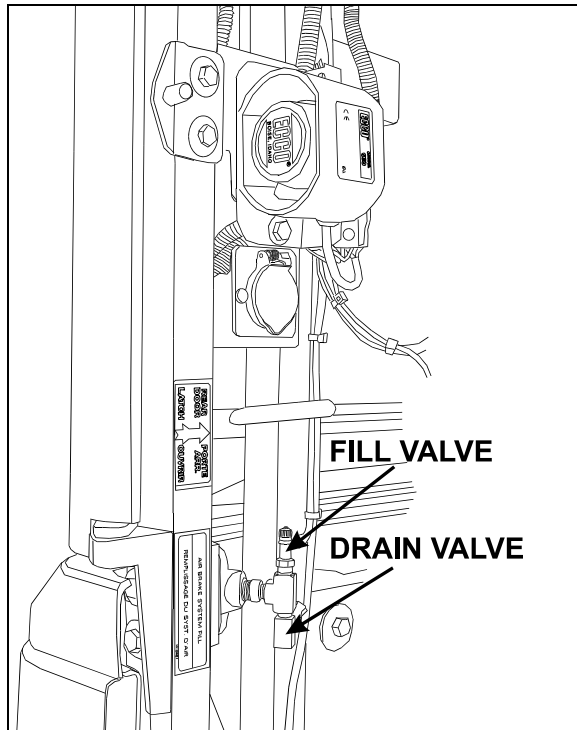

FIGURE 43: REAR VALVE LOCATION

12202

#### 12.1.3 Secondary Air Tank

This tank is located in front wheelhousing, between air springs. The tank is installed vertically and is provided with a bottom drain valve (Fig. 42).

It is recommended to purge the tank by its bottom drain valve, every 12,500 miles (20 000 km) or once a year, whichever comes first.

#### 12.1.4 Accessory Air Tank

The accessory air tank is installed next to the secondary air tank. The tank is installed vertically and is provided with a bottom drain valve (Fig. 42).

It is recommended to purge the tank by its bottom drain valve, every 12,500 miles (20 000 km) or once a year, whichever comes first.

A remote drain valve is located in front service compartment (Fig. 44) underneath the accessory air filter. Refer to Section 12, paragraph "5. Accessory Air Filter" of the maintenance manual for daily purge procedure.

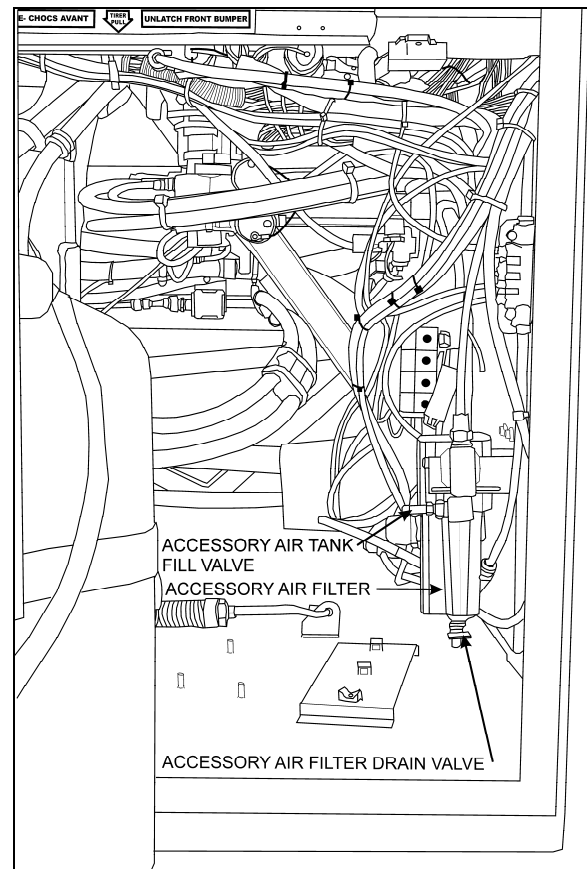

FIGURE 44: FRONT VALVE LOCATION

12218



### 12.1.5 Expansion Air Tank

Two expansion tanks are located in front wheelhousing. These air tanks are located behind secondary and accessory air tank. Also, six expansion tanks are located near rear air springs (Fig. 42). Expansion tanks are connected in series with air springs. Expansion tanks are used to lower the stiffness of the air spring. They are provided with a bottom drain valve.

It is recommended to purge them, with all other tanks, every 12,500 miles (20 000 km) or once a year, whichever comes first.

### 12.2 EMERGENCY FILL VALVES

The vehicle is equipped with two air system emergency fill valves to supplement the air system when air pressure is low and engine cannot be operated.

**The rear valve** is located in engine compartment and accessible from engine R.H. side door (Fig. 43).



#### CAUTION

No other point should be used to supply air system. The maximum allowable air pressure is 125 psi (860 kPa).

The front valve is located in the front service compartment close to accessory air filter (Fig. 44).

These two air valves are fitted with the same valve stems as standard tires, and can be filled by any standard external air supply line.

The rear valve will supply air for all systems (brakes, suspension and accessories) while the front valve will supply air for accessories only.



#### CAUTION

Air filled through these two points will pass through the standard air filtering system provided by Prévost. Do not fill air through any other points.

## 13. HUB UNIT AND SWIVEL ASSEMBLY

### 13.1 HUB BEARING INSPECTION

An inspection should be made at intervals of 30,000 miles (48 000 km).

- Apply parking brake, raise wheels off the ground and support axle on stands. When the wheels are raised, they should revolve quite freely without roughness.
- Place magnetic base of a dial indicator on brake caliper and position dial indicator stem against a convenient marked spot on face of hub flange.
- With dial indicator in position pull hard but steadily on hub flange and oscillate at same time until a steady reading is achieved.
- Without releasing the pressure, turn bearing so that dial indicator stem contacts marked spot and note reading on indicator.
- Push bearing flange hard and oscillate as before until a steady reading is achieved.
- Without releasing the pressure, turn bearing so that indicator stem again contacts the marked spot and note new reading on indicator.
- The difference between readings is the amount of mounted end play in bearing unit.
- The mounted end play figure should not exceed **0.050 mm (0.002")** for a new bearing and **0.20 mm (0.008")** for a bearing which has been in service.

#### NOTE

*If original bearing unit is re-fitted, and end-float is measured at 1 mm, with hub not fully tightened to correct torque, then the retaining clip within the unit is damaged and a new unit must be fitted.*

### 13.2 KING PIN INSPECTION

An inspection should be made at intervals of 30,000 miles (48 000 km).

Aspects to be considered are: Lateral slackness and Vertical slackness.

#### NOTE

*Before commencing checks, apply parking brake, raise wheels off ground and support axle on stands.*

#### 13.2.1 Checking Lateral Slackness

- While this is being carried out the brake must be applied.

## Section 16: SUSPENSION

---

- Place a set-square with its stock on ground and its blade against tire wall.
- Place a mark on ground to indicate position of stock end.
- Insert a lever through bottom cut-out of wheel and lever it upwards thus moving set-square outwards.
- Mark changed position of stock end.
- Maximum allowable stock displacement is given as follows: **for 22.5" wheels = 8mm (5/16")**.
- If displacement exceeds stated allowance then need for bush / bearing attention and possible renewal, is in evidence.

### 13.2.2 Checking Vertical Slackness

- This is measured by a dial indicator anchored to axle beam and having its pointer placed vertical against swivel top.
- Place a jack against underside of swivel and, while applying a lifting force, observe any movement on indicator dial.
- **If vertical movement is evident and it exceeds 0.040" (1.02mm)** then readjustment of swivel is required by adjusting thickness of bearing adjusting washers.

Refer to "DANA SPICER Service Manual General Information, Maintenance Manual Model NDS and Maintenance Manual NDS Axles" annexed to section 11 "*Rear Axles*".

## 14. TORQUE TABLE

DESCRIPTION	QTY	TORQUE (DRY)	
		Lbf-ft	Nm
Pitman Arm to Steering Gear Fixing Nut	1	470-570	637-773
Steering Gear to Mounting Bracket Bolts	5	365-405	495-550
Drag Link to Pitman Arm Stud Nut *	1	150-200	203-271
Drag Link to Bell crank Stud Nut *	1	150-200	203-271
Drag Link Socket End Clamp Bolt Nut	2	40-60	55-80
Relay Rod to Bell crank Stud Nut *	1	150-200	203-271
Relay Rod to Idler Arm Stud Nut *	1	150-200	203-271
Tie Rod to Bell crank Stud Nut *	1	150-200	203-271
Tie Rod to Idler Arm Stud Nut*	1	150-200	203-271
Tie Rod to Steering Arm Stud Nut *	2	150-200	203-271
Tie Rod End Clamp Bolt Nut	4	40-60	55-80
Steering Arm to Steering Knuckle Bolt (M20 X 65)	2	520-575	705-780
Steering Arm to Steering Knuckle bolt (M24 X 100)	2	751-830	1018-1125
Torque Rod Stud Nut	2	160-215	217-292
Torque Rod Mounting Bracket Stud	4	90-110	122-150
Torque Rod Mounting Bracket Nut	4	140-155	190-210
Idler Arm and Bell Crank Mounting Spindle Nut	8	90-105	122-142
Jacking Point Bracket Nut	8	70-80	95-110
Sway Bar Bushing Collar Nuts	8	80-100	110-135
Sway Bar Link Upper and Lower Nuts (Front Suspension)	2	165-200	225-270
Sway Bar Link Upper Nuts (Rear Suspension)	2	100-120	135-160
Sway Bar Link Lower Nuts (Rear Suspension)	2	70-80	95-110
Shock Absorber Pin	2	350-400	475-545
Shock Absorber Support	4	145-165	196-224
Shock Absorber Upper Mounting Pin Stud Nut	2	70-85	95-115
Shock Absorber Lower Mounting Pin Nut	2	60-75	81-102
Air Spring Lower Nut	4	20-25	27-34
Air Spring Upper Nut	2	20-25	27-34
Upper A-Arm Central Ball Joint (Hex Castle Nut)*	2	310-340	420-461
Upper A-Arm Ball Joint	8	230-255	312-346
Lower A-Arm Central Ball Joint (Hex Castle Nut)*	2	490-540	664-732
Lower A-Arm Ball Joint	8	270-300	366-407

\* Tighten nut to specified torque, then advance to next aligning cotter pin slot and install a new cotter pin.

**15. SPECIFICATIONS**

**Front Axle Air Springs**

Make..... Goodyear Tire and Rubber  
 Model..... 1400  
 Type ..... Mae West  
 Diameter..... 14.5 inches  
 Air Inlet ..... 1/2" - 14 NPTF  
 Prévost number..... 630239

**Tag Axle Air Springs (WE)**

Make..... Goodyear Tire and Rubber  
 Model..... 1200  
 Type ..... Mae West  
 Nominal diameter ..... 12" (304 mm)  
 Prévost number..... 630151

**Tag Axle Air Springs (W5)**

Make..... Goodyear Tire and Rubber  
 Model..... 1100  
 Type ..... Mae West  
 Nominal diameter ..... 11.5" (304 mm)  
 Prévost number..... 630259

**Drive axle air springs**

Make..... Goodyear Tire and Rubber  
 Model..... 1100  
 Type ..... Double Flare  
 Nominal diameter ..... 11.5" (292 mm)  
 Prévost number..... 630105

**Front axle shock absorbers**

Make..... Arvin  
 Color..... Black  
 Piston Diam. .... 1 5/8 inch  
 Collapsed length ..... 14.16 inches  
 Extended length ..... 22.44 inches  
 Prévost number..... 630136

**Drive and tag axle shock absorbers**

Make..... Sachs  
 Color..... Black  
 Type ..... N45X225HA  
 Ext. Diam..... 75 mm  
 Collapsed length ..... 15.51" (394 mm)  
 Extended length ..... 24.37" (619 mm)  
 Prévost number..... 630253

**Height control valve (Front)**

Make..... Barksdale  
 Quantity used ..... 1  
 Prévost number..... 630157

**Height control valve (Rear)**

Make..... Barksdale  
 Quantity ..... 2  
 Prévost number ..... 630156

**Radius rod bushing**

Make..... Prévost  
 Prévost number ..... 630021

**Loctite**

Make..... Loctite  
 Prévost number ..... 680039

**Sway bar bushing (Front Suspension)**

Make..... Prévost  
 Prévost number ..... 630020

**Sway bar bushing (Drive Axle)**

Make..... Prévost  
 Prévost number ..... 130953

**Sway bar link**

Make..... Tennaco Automotive  
 Prévost number ..... 630230

**Shock absorber bushings**

Make..... Monroe  
 Prévost number ..... 630062

**Air regulator**

Make..... Norgren  
 Recommended pressure sett..... 90 psi (621 kPa)  
 Prévost number ..... 641352

**Shim (Camber Adjustment)**

Thickness ..... 3.175 mm  
 Prévost number ..... 160993  
 Thickness ..... 6.35 mm  
 Prévost number ..... 160992