

# SECTION 23: ACCESSORIES

## CONTENTS

<b>1. ROOF ANTENNA INSTALLATION</b> .....	<b>3</b>
<b>2. HUBODOMETER</b> .....	<b>3</b>
2.1 DESCRIPTION.....	3
2.2 OPERATION .....	3
2.3 REMOVAL .....	3
2.4 INSTALLATION .....	3
<b>3. BACK-UP CAMERA AND MONITOR</b> .....	<b>3</b>
<b>4. COLD STARTING AID</b> .....	<b>3</b>
4.1 WITH DETROIT DIESEL S60 ENGINE.....	3
4.1.1 <i>Preventive Maintenance</i> .....	4
4.1.2 <i>Troubleshooting (If System Is Non-Functioning)</i> .....	4
4.1.3 <i>Thermal Cutout Valve Quick Test</i> .....	5
4.2 WITH VOLVO D13 ENGINE.....	5
<b>5. AIR HORN VALVE</b> .....	<b>5</b>
5.1 AIR HORN VALVE MAINTENANCE.....	5
<b>6. HEADLIGHTS CLEANING SYSTEM</b> .....	<b>6</b>
6.1 GENERAL DESCRIPTION .....	6
6.2 WASHER FLUID REFILLING.....	6
6.3 WASHER NOZZLES ADJUSTMENT .....	6
<b>7. WINDSHIELD WIPERS AND WASHERS</b> .....	<b>7</b>
7.1 GENERAL DESCRIPTION .....	7
7.2 WIPER ARM.....	7
7.2.1 <i>Wiper Arms Positioning</i> .....	8
7.3 WINDSHIELD WIPER MOTOR.....	9
7.3.1 <i>Windshield Wiper Motor Replacement</i> .....	9
7.4 TROUBLESHOOTING .....	10
<b>8. TIRE PRESSURE MONITORING SYSTEM (TPMS)</b> .....	<b>10</b>
8.1 TIRE VALVE INSTALLATION.....	11
8.2 BERU SENSORS INSTALLATION .....	12
<b>9. AUTOMATIC FIRE SUPPRESSION SYSTEM (AFSS)</b> .....	<b>13</b>
9.1 PERIODIC MAINTENANCE .....	13
<b>10. SPECIFICATIONS</b> .....	<b>16</b>

## ILLUSTRATIONS

FIGURE 1: HUBODOMETER.....	3
FIGURE 2: ENGINE .....	4
FIGURE 3: COLD STARTING AID .....	4
FIGURE 4: AIR HORN VALVE .....	5
FIGURE 5: HEADLIGHTS CLEANING SYSTEM.....	6
FIGURE 6: TUBING AND FITTINGS.....	6
FIGURE 7: WASHER NOZZLES ADJUSTMENT .....	7
FIGURE 8: MULTIFUNCTION LEVER.....	7
FIGURE 9: WINDSHIELD WASHER RESERVOIR .....	7
FIGURE 10: WINDSHIELD WIPER INSTALLATION.....	8
FIGURE 11: WINDSHIELD WIPER (MOTOR SIDE) .....	8
FIGURE 12: WINDSHIELD WIPER ( DRIVER SIDE) .....	8
FIGURE 13: DRIVING MECHANISM (DRIVER SIDE) .....	8
FIGURE 14: DRIVING MECHANISM (MOTOR SIDE) .....	9
FIGURE 15: WIPER ARMS POSITIONING .....	10
FIGURE 16: W5 FIRE EXTINGUISHER INSTALLATION .....	15
FIGURE 17: WE FIRE EXTINGUISHER INSTALLATION .....	15
FIGURE 18: WE NOZZLE BRACKETS IDENTIFICATION AND INSTALLATION .....	16

## 1. ROOF ANTENNA INSTALLATION

- Find the desire location and drill a hole according to specification.
- To remove dirt and grease, wash hole edge with alcohol.
- If so equipped, remove foam padding ring from antenna to free the metal surface (foam can produce air bulbs in new rubber seal).
- With SIKA 205, wash the edge of the hole and the antenna base surface, wait at least two (2) minutes for chemical evaporation.
- Apply new seal SIKA 221 on both, edge of the hole and antenna base.
- Fix the antenna in place.
- Remove excess seal and complete a finishing joint all around the antenna base.

## 2. HUBODOMETER

### 2.1 DESCRIPTION

An optional wheel hubodometer (Fig. 1) may have been installed on the R.H. side of the drive axle. It indicates the total distance in miles or kilometers covered by the coach since it has left the factory, including road testing.

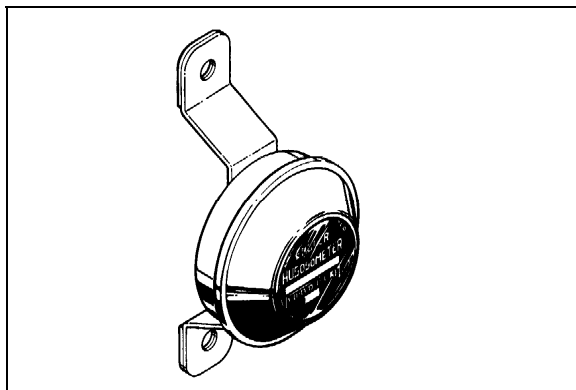

FIGURE 1: HUBODOMETER

23024

### 2.2 OPERATION

The hubodometer is calibrated for a specific wheel size (diameter). Wheel rotation causes a mechanism inside the hubodometer to record distance after a predetermined number of rotations. The unit should be serviced at a competent speedometer repair facility.

### NOTE

*Do not use paint, solvent or thinner on hubodometer face or on plastic hubcaps. Do not weld on hubodometer.*

### 2.3 REMOVAL

To remove the unit, remove the two lock nuts and washers securing it to the wheel hub, and pull the unit off the studs.

### 2.4 INSTALLATION

Place the hubodometer unit over the wheel hub studs. Replace the lock washers and nuts. Torque stud nuts to 110-165 Lbf-ft (150-225 Nm).

## 3. BACK-UP CAMERA AND MONITOR

An optional back-up camera is available which provides the driver with visual assistance when backing-up. The camera is automatically activated when the transmission is put in reverse gear and the ignition switch is "ON". The TV monitor is mounted on top of the dashboard. Refer to the Owner's Manual under "Controls & Instruments".

## 4. COLD STARTING AID

### 4.1 WITH DETROIT DIESEL S60 ENGINE

The vehicle can be equipped with an electrically-operated type ether cold starting aid designed to ease engine starting when temperature is low.

On vehicles equipped with cold starting aid, the system consists of the main following parts:

- Ether starting aid switch
- Ether cylinder
- Solenoid valve (24 V)
- Thermal cutout valve
- Atomizer

The control rocker switch is located on the dashboard. This switch is provided with a locking mechanism to avoid accidental use when engine is running. To activate the ether starting aid, proceed as follows:

1. Prior to cranking engine, press down rocker switch for three seconds to fill solenoid valve.
2. Release switch to discharge shot.

## Section 23: ACCESSORIES

3. Allow three seconds for shot to discharge.
4. Start engine, use additional shots if necessary to keep engine running.



### CAUTION

This practice should be performed only when absolutely necessary. Excessive use of fluid could result in serious engine damage.

The ether cylinder and solenoid valve assembly are mounted on the engine compartment wall and are accessible from the engine compartment R.H. side door.

The thermal cutout valve is mounted on the engine (radiator side). Its function is to prevent discharge of ether when engine is warm (over 90 F (32 C)). The atomizer is installed on top of the air intake duct (Fig. 2).

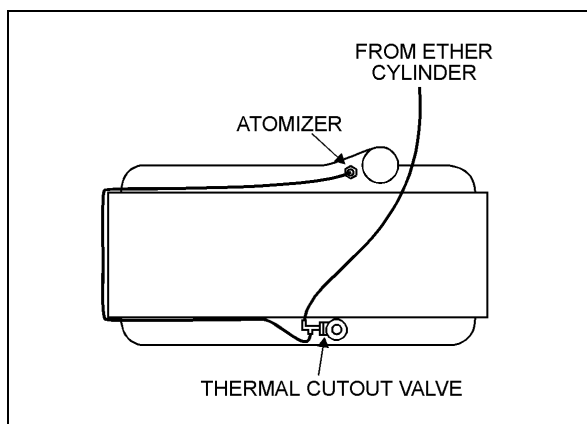

FIGURE 2: ENGINE

23032

#### 4.1.1 Preventive Maintenance

During the summer months, remove cylinder to avoid high temperature actuation of the cylinder safety relief device. Always screw valve cap into solenoid valve opening to prevent entrance of road dirt. When removing cylinder, be careful to prevent dirt from entering the valve.

#### 4.1.2 Troubleshooting (If System Is Non-Functioning)



### DANGER

During the following test, direct free end of tube away from personnel and all sources of ignition as this fuel is extremely flammable. Avoid breathing vapors and contacting fuel with skin. Never smoke during test.

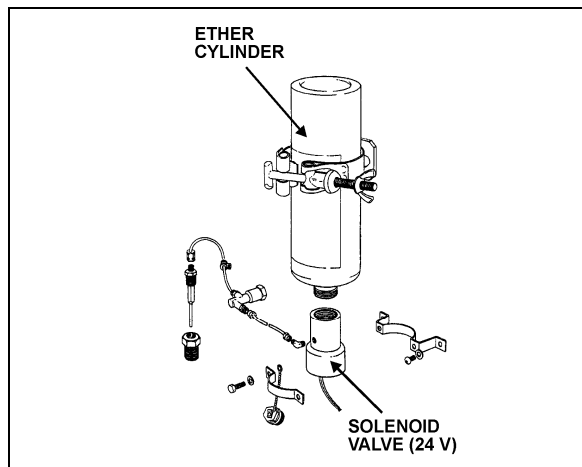

FIGURE 3: COLD STARTING AID

23048

1. Check cylinder for hand tightness and fuel supply (Fig. 3). Empty cylinder weight is approximately 17 oz (480 g); full cylinder weight is approximately 35 oz (990 g). If cylinder is empty, replace it. Before replacing cylinder, install new valve gasket in solenoid valve.
2. If still not functioning, disconnect tubing at solenoid valve fitting. Actuate solenoid valve. (Ask an assistant to actuate solenoid valve using the rocker switch on the dashboard).
  - If solenoid valve is non-functioning, check electric circuit, (refer to wiring diagrams). If sound, remove and replace the solenoid valve. If not, repair electric circuit.
  - If valve is functioning, reassemble valve fitting and connect tube. Disconnect tube at thermal cutout valve from port "Tube from valve".
3. Actuate the solenoid valve.
  - If fuel is not discharged from tube, remove tube and blow out or replace.
  - If fuel is discharged, connect tube to thermal cutout valve, and disconnect other tube.
4. Actuate the solenoid valve.
  - If fuel is not discharged, replace the cut-out valve.

### NOTE

If engine coolant temperature is 90°F (32°C) or over, it is normal that fuel is not discharged as the valve is in closed position.

- If fuel is discharged, connect tube to thermal cutout valve, and disconnect tube from atomizer.
5. Actuate the solenoid valve.
    - If fuel is not discharged from tube, fuel line is clogged. Remove tube and blow out or replace.
    - If fuel is discharged, replace the atomizer.

#### 4.1.3 Thermal Cutout Valve Quick Test

1. Engine coolant temperature must be below 90 F (32 C).
2. Temporarily disconnect tube at thermal cutout valve from port "*Tube to atomizer*".
3. Actuate solenoid valve (Ask an assistant to actuate solenoid valve by means of the rocker switch on the dashboard). Fuel should be discharged through the thermal cutout valve.



### DANGER

Avoid breathing vapors and contacting fuel with skin. Never smoke during test.

4. Reconnect tube to thermal cutout valve.
5. Start engine, using cold starting aid if necessary. Stop engine when it reaches operating temperature.
6. Disconnect tube at thermal cutout valve as in step 2, and repeat step 3. No fuel should be discharged.

#### 4.2 WITH VOLVO D13 ENGINE

When starting a cold engine, the intake air should be warmed up by using the intake air preheater. Turn the ignition switch to the ON position. The preheater will not engage at coolant temperature above 54°F (12°C). If the coolant temperature is below 54°F (12°C), the preheater will engage and will light the preheater telltale between 0 and 50 seconds, depending on the engine coolant temperature. Wait before the preheater telltale has turned off before starting the engine.

If necessary, once the engine has started, the preheater will reengage (post heating) for the same length of time as the preheat time.



### WARNING

**Do not** use ether or other combustible starting aid fluid on any engine equipped with an intake air preheater. If the engine is equipped with a preheater, introduction of ether or similar starting aids could cause a fire or explosion resulting in severe property damage, serious personal injury or death.

Engines not equipped with an intake air preheater may, depending on coolant temperature, take longer to start. If this should happen, **DO NOT** release the ignition key until the engine has started (while still observing the 15 second maximum cranking time).

#### 5. AIR HORN VALVE

The air horn valve is located in the front service compartment and the air horn valve button is on the steering wheel center.

##### 5.1 AIR HORN VALVE MAINTENANCE

When needed, the air horn valve can be serviced or replaced using the following procedure:

1. Unplug the cable connector;
2. Disconnect the air tubes;
3. Loosen the retaining bolts;
4. Service or replace the air horn valve;
5. Reinstall by reversing procedure.

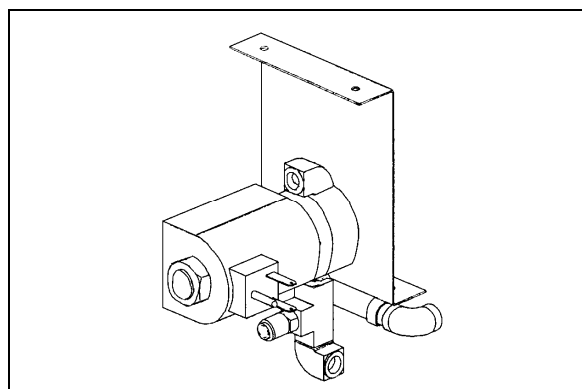

FIGURE 4: AIR HORN VALVE

23230

## 6. HEADLIGHTS CLEANING SYSTEM

### 6.1 GENERAL DESCRIPTION

**NOTE**

*When inspecting the headlights cleaning system, check the washer fluid hoses, fittings and connectors to be sure they are properly connected and seal with no restriction to the flow of washer fluid. Check that the washer nozzles are properly aimed.*

The headlights cleaning system is independent from the windshield washer system and has its own washer fluid reservoir located in the front electrical and service compartment.

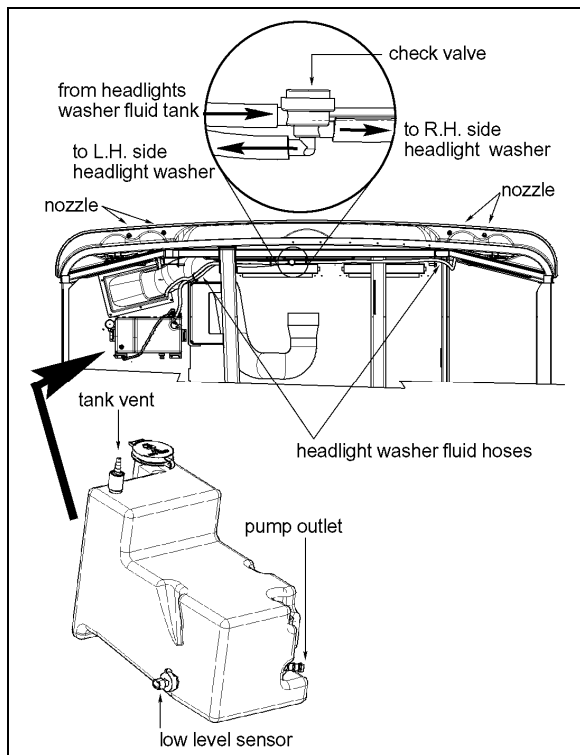

FIGURE 5: HEADLIGHTS CLEANING SYSTEM 23380

However, this system shares the same telltale light than the windshield washer low level sensor (refer to Owner's manual for operation). Each pressing of this switch produces 2 successive 0.7 seconds jets.



**CAUTION**

Do not operate the headlights washer while the washer fluid reservoir is empty. This may damage the washer fluid pump.

### 6.2 WASHER FLUID REFILLING

Open the filler neck cap and add regular windshield washer fluid as required. The tank has a capacity of 10 liters (2.6 US gallons). You may use water or windshield washer fluid as well but, during cold weather days, use windshield washer fluid suitable for freezing temperature only.

### 6.3 WASHER NOZZLES ADJUSTMENT

To avoid waste of washer fluid, assure the fluid jets are properly aimed. Adjust nozzles so they aim as described in figure 7. Align the jet adjustment tool #800377 with the reference line shown on the front view detail. As seen on the side view, position the end of the adjustment tool to a distance of 1/2" (high beam) and 1" (low beam) from the top of the headlight for proper aiming.

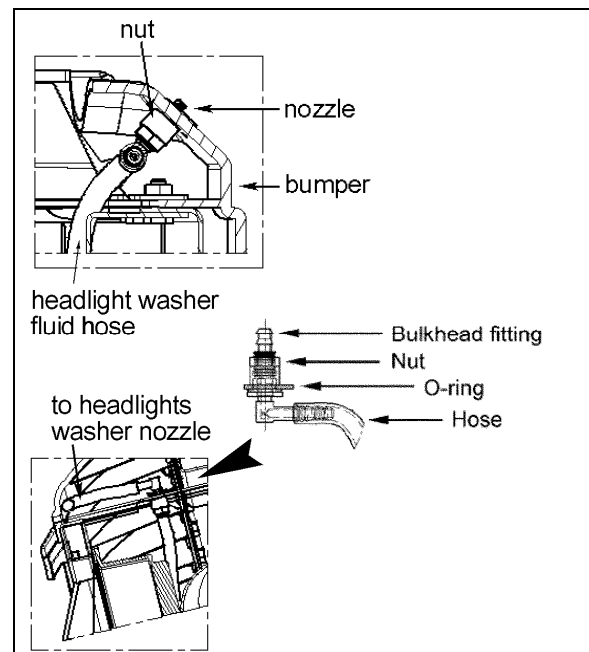

FIGURE 6: TUBING AND FITTINGS 23381



**CAUTION**

Because they are made of plastic, firmly tighten nozzle and bulkhead fittings by hand only.

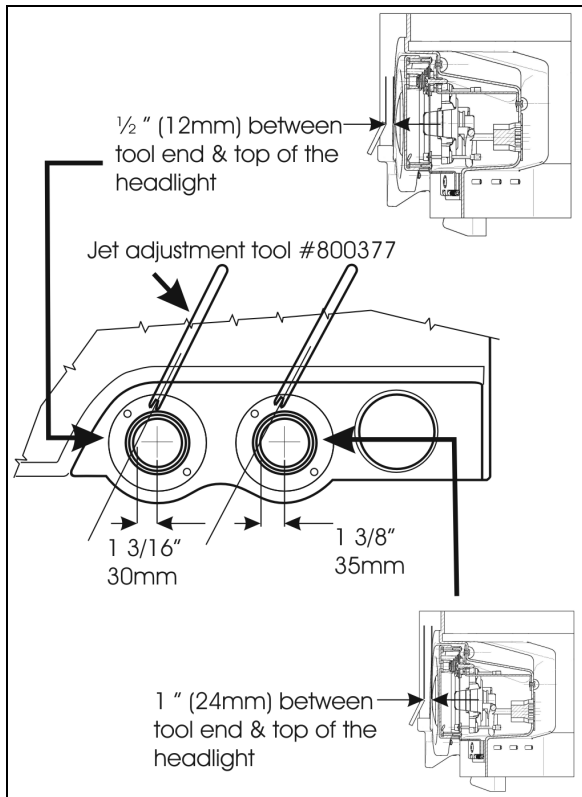

FIGURE 7: WASHER NOZZLES ADJUSTMENT 23382

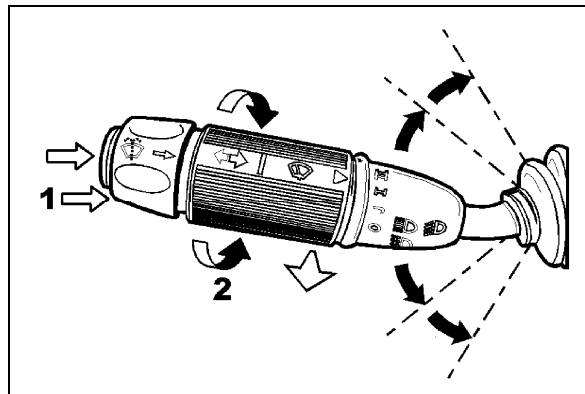

FIGURE 8: MULTIFUNCTION LEVER 23133

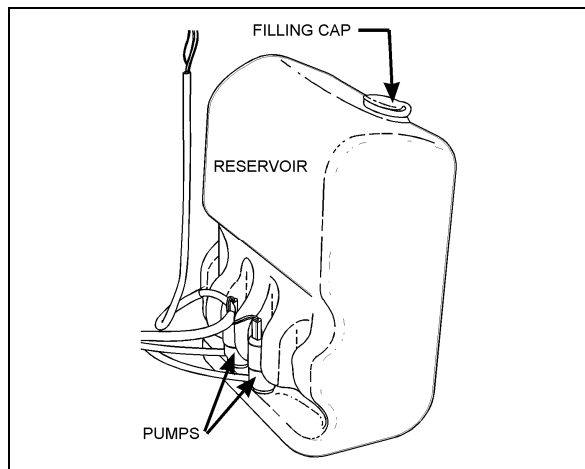

FIGURE 9: WINDSHIELD WASHER RESERVOIR 23220

7. WINDSHIELD WIPERS AND WASHERS

7.1 GENERAL DESCRIPTION

**NOTE**

When installing a wiper motor, arm or blade, follow recommended procedures to prevent misalignment, binding or malfunction. Check the windshield washer liquid hoses, fittings and connectors to be sure they are properly connected and seal with no restriction to the flow of washer liquid. Check that wiper arms have the proper sweep position and the washer nozzles are aimed so that spray is within the proper wiper pattern.

The windshield wipers are controlled by one electric wiper motor that is accessible for maintenance after removing the appropriate access panel beside the footwell (refer to figure 10).

Turn the multifunction lever forward to activate windshield wipers (item 2, fig. 8). The first position operates the wipers at low speed and the second position operates the wipers at high speed. Turning the lever backwards will operate the wipers in the intermittent mode.

The windshield washer pumps are electrically operated and are controlled by a washer control ring on the multifunction lever (item 1, fig. 8).

The windshield washer reservoir is located in the front service compartment (fig. 9). This unit pumps the washer liquid to the spray nozzles where it is dispersed across the windshield.

7.2 WIPER ARM

Check operation of the wipers for proper blade sweep and angle.

**CAUTION**

Do not attempt to manually move the wiper arms to make wiper blade sweep adjustments as damage to the wiper linkage or motor may occur. If it is necessary to adjust the sweep of blades, remove the arms and make adjustment by positioning the arms using serration on the wiper arm pivot shafts.

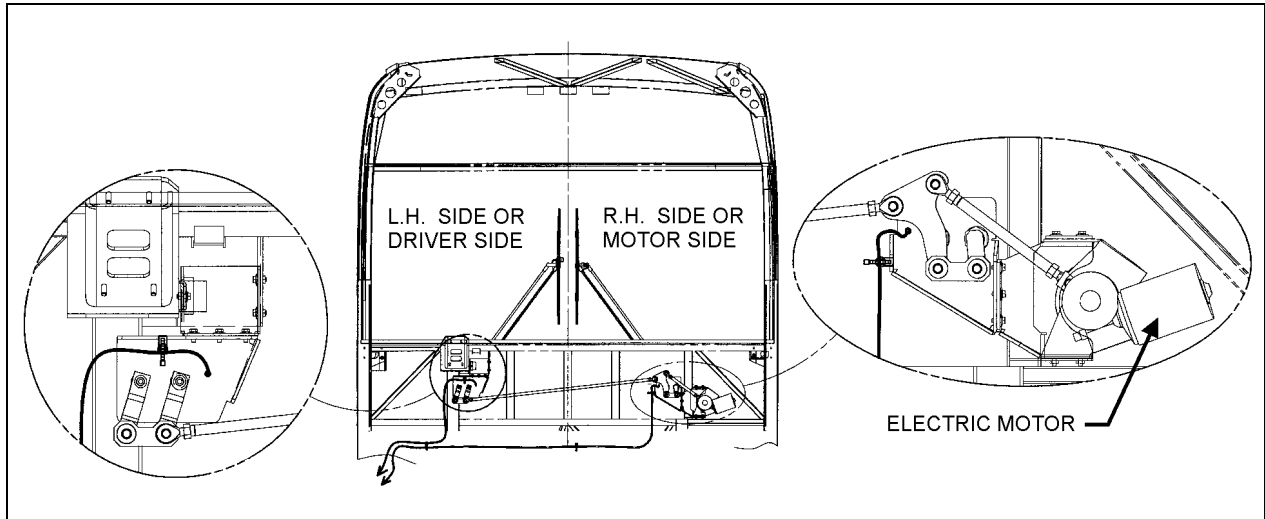

FIGURE 10: WINDSHIELD WIPER INSTALLATION

23287

### 7.2.1 Wiper Arms Positioning

1. Reinstall the wiper arms and position as shown in figure 15. Before positioning the wipers at their final position, tighten the nuts to 9 Ft-lbs (12 Nm) at first.
2. To find the final position of the wiper arms, lift then release the wiper arm so it falls back on the windshield

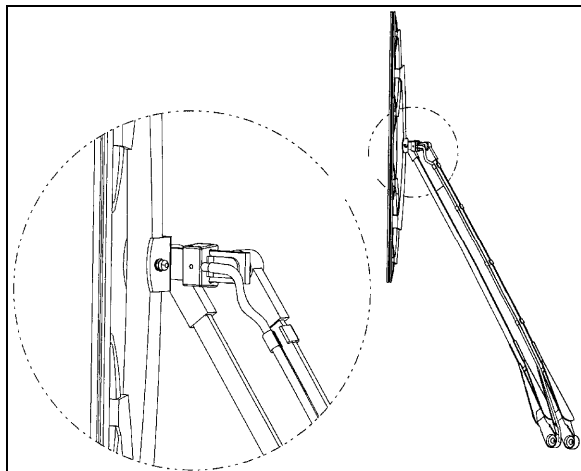

FIGURE 11: WINDSHIELD WIPER (MOTOR SIDE) 23335

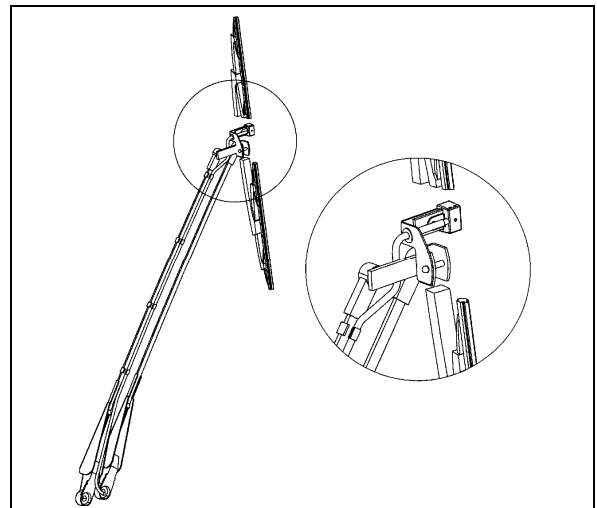

FIGURE 12: WINDSHIELD WIPER ( DRIVER SIDE) 23334

3. When the final position is found, tighten the wiper arm nuts to 22 Ft-lbs (30 Nm). Wait 30 minutes and tighten again to 22 Ft-lbs.

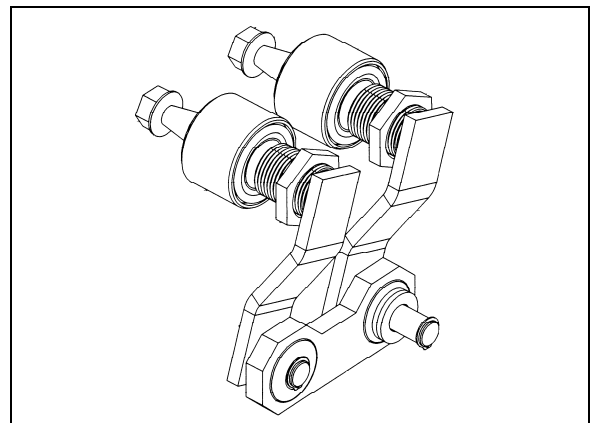

FIGURE 13: DRIVING MECHANISM (DRIVER SIDE) 23334



4. Lower the protective cover.
5. Connect the windshield washer tubing at the base of the wiper arm.
6. Check the adjustment on a wet windshield.

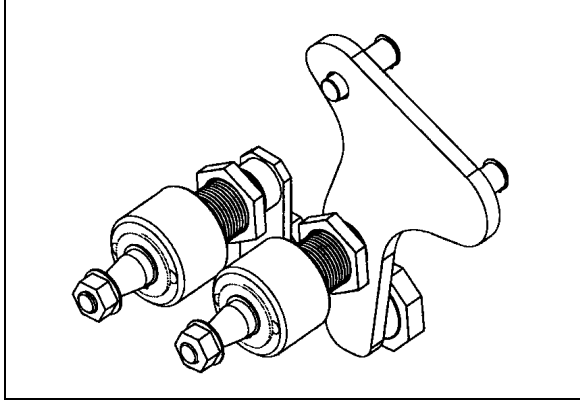

FIGURE 14: DRIVING MECHANISM (MOTOR SIDE) 23254

## 7.3 WINDSHIELD WIPER MOTOR

### 7.3.1 Windshield Wiper Motor Replacement

The windshield wiper motor is located at lower front of the vehicle, behind the defroster panel. Refer to figure 8 for motor location.



### WARNING

Park vehicle safely, apply parking brake, stop engine and set battery master switch to the "OFF" position prior to working on the vehicle.

1. Remove the Phillips-head screws retaining the defroster panels, and remove panels.
2. Disconnect wiring connector from the windshield wiper motor.
3. Loosen clamping screw retaining the lever at the end of the motor driving shaft.
4. Remove the three bolts holding the motor to the steel plate.
5. Remove the windshield wiper motor (Prevost #800328), reverse removal procedure to reinstall.

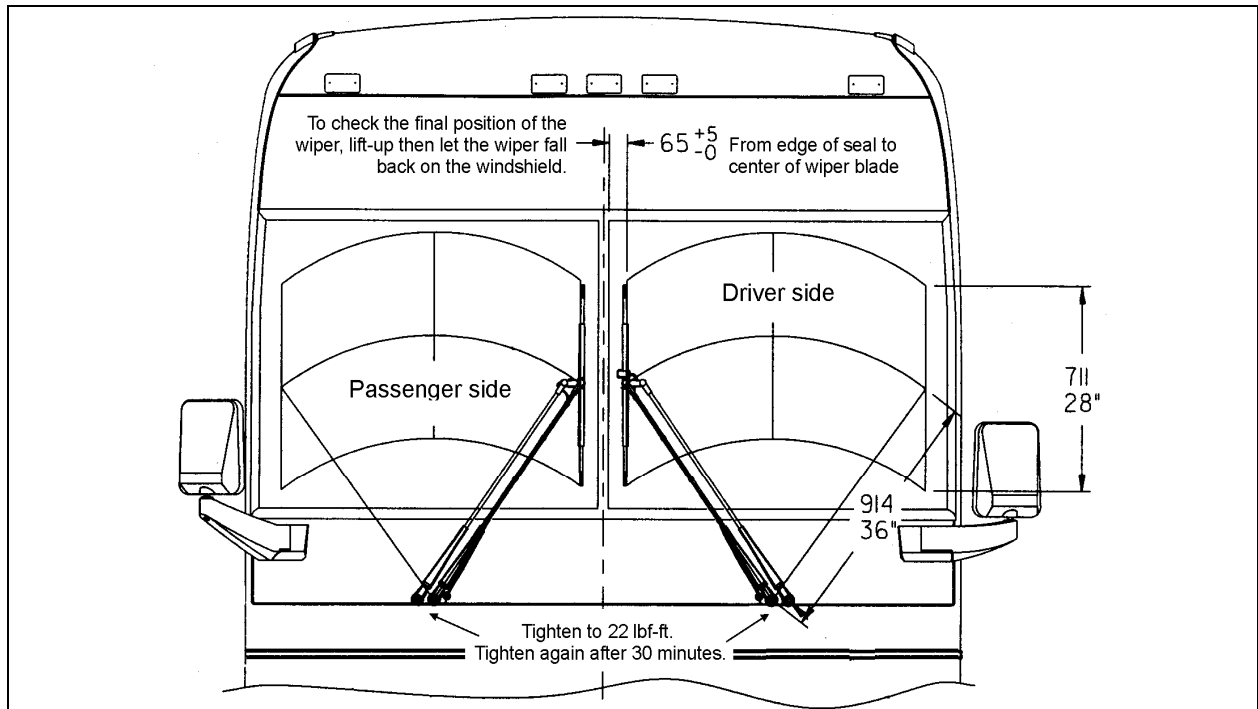

FIGURE 15: WIPER ARMS POSITIONING

23253

#### 7.4 TROUBLESHOOTING







SYMPTOM	PROBABLE CAUSE	REMEDY
FAIL TO SPRAY WASHER FLUID	<ul style="list-style-type: none"> <li>A. Reservoir empty.</li> <li>B. If below 32°F (0°C), improper washer fluid frozen.</li> <li>C. Contamination in tubing or nozzles.</li> <li>D. Tubing damage.</li> <li>E. Tubing bent (kinked) or off one or more connections.</li> </ul>	<ul style="list-style-type: none"> <li>A. Add proper fluid.</li> <li>B. Store coach or parts in heated area, then purge system with low-temperature solution.</li> <li>C. Remove with compressed air, if severely clogged, replace items.</li> <li>D. Replace section.</li> <li>E. Realign tubing and/or refit. Trim end to ensure proper fit or replace.</li> </ul>
INADEQUATE SPRAYING	<ul style="list-style-type: none"> <li>A. Tubing failure.</li> </ul>	<ul style="list-style-type: none"> <li>A. Replace tubing.</li> </ul>
SLOW OPERATION	<ul style="list-style-type: none"> <li>A. Improper solution.</li> <li>B. Jet stream improperly directed.</li> <li>C. Check if valve is stuck in the open position.</li> </ul>	<ul style="list-style-type: none"> <li>A. Replace with proper type solution.</li> <li>B. Reposition nozzles.</li> <li>C. Remove, clean or replace.</li> </ul>

### 8. TIRE PRESSURE MONITORING SYSTEM (TPMS)

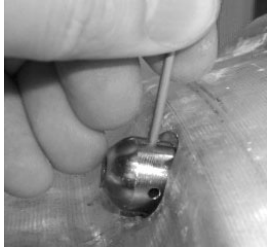

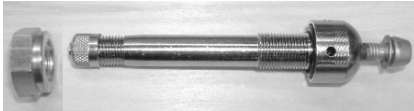
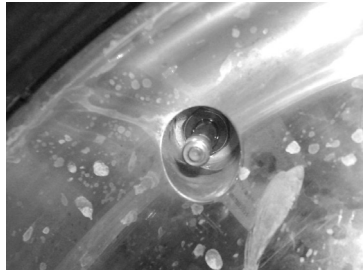
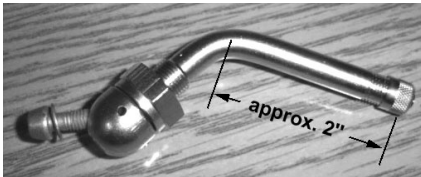
The optional active tire pressure and temperature monitoring system is a sensing device designed to identify and display tire operating data and activate an alert or warning when pressure or temperature irregularities are detected.

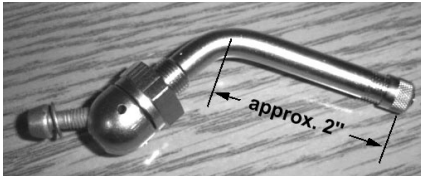
For more information on the operation and troubleshooting of the system, refer to the Owner's Manual, chapters "Controls and Instruments", "Safety Features and Equipment" and also "Appendix E".

8.1 TIRE VALVE INSTALLATION

<p><b>Use as required a small rod to hold the valve in place when tightening.</b></p>			
<p><b>Steel Wheels</b></p>	<p><u>All wheels</u>                      a) Install Beru valve                      Torque valve to 44.5lb-in +/- 9.5                      b) no extension piece</p>	 <p>#Prevost 681083</p>	
	<p><u>Front axle and tag axle wheels with 365 tires-</u>                      a) Remove Alcoa valve                      b) Install Beru valve                      Torque valve to 102lb-in +/- 22                      c) no extension piece</p>	 <p>#Prevost 651080</p>	
<p><b>Aluminum Wheels (new Hub-Mounted wheels)</b></p>	<p><u>Front axle and tag axle wheels with 315 tires-</u>                      a) Remove Alcoa valve                      b) Install Beru valve                      Torque valve to 102lb-po +/- 22                      c) Small extension piece (approx 50mm)</p>	 <p>#Prevost 651081</p>	
	<p><u>Drive axle inner and outer wheels with 315 tires-</u>                      a) Remove Alcoa valve                      b) Install Beru valve                      Torque valve to 102lb-in +/- 22                      c) no extension piece</p>	 <p>#Prevost 651081</p>	

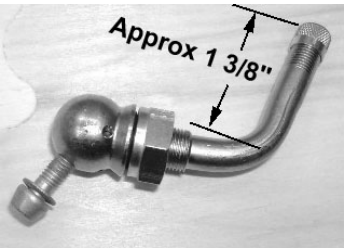
Section 23: ACCESSORIES

	<p><b><u>"Super Single" Tires</u></b>  a) Remove Alcoa valve  b) Install Beru valve  Torque valve to 102lb-in +/- 22  c) no extension piece</p>	 <p>Approx 1 3/8"</p> <p>#Prevost 651079</p>	
--	---	---	---

<p>Aluminum wheels (former Stud-Mounted wheels)</p>	<p><b><u>All wheels</u></b>  a) Remove Alcoa valve  b) Install Beru valve  Torque valve to 102lb-in +/- 22  c) no extension piece</p>	 <p>#Prevost 651082</p>	
---	---	---	---

 **CAUTION**

When replacing Alcoa valve stems, it is recommended to lubricate the threads and O-ring with a non-water based tire lubricant.

When valve stem extensions are used, it is recommended that valve stem stabilizers be used.

8.2 BERU SENSORS INSTALLATION

***IMPORTANT NOTE***  
*Beru sensors have a limited lifespan (5 years on average)*

<p>Install sensor onto valve. Torx screw T-20. Torque to 35lb-in (4Nm) (supplier specification for the screw).</p> <p>Make sure sensor rests against rim flange.</p> <p><b>IMPORTANT</b></p> <p>Use the screw only once. This screw uses a thread lock. Replacement screw #651084.</p>	
--	--

<p>Note bar code and tie it up using wheel holes. Use supplied removable tie-rop.</p>	
<p><b>Decal</b>  <b>Glue decal facing the valve.</b></p>	<p><b>#651091 ENGLISH #651090 BILINGUAL</b></p>

**9. AUTOMATIC FIRE SUPPRESSION SYSTEM (AFSS)**

This optional system is used to shut down the engine and to extinguish a fire in the engine compartment or in the vicinity of the preheating system if so equipped.

The system operation is fully automatic and does not require assistance from the operator, however if required, the system can be manually activated by the operator at any time.

Refer to Prevest Owner’s Manual for system operation and operational sequence (fire).

If more information is needed on the system, please refer to Kidde Dual Spectrum “Operation & Maintenance Manual annexed at the end of this section.

**9.1 PERIODIC MAINTENANCE**

**PRE-TRIP**

- Verify that the Protection Panel “SYSTEM OK” lamp is on solid green.

**EVERY 3000 MILES OR MONTHLY** (whichever comes first)

**General**

- Verify that neither the protected equipment nor the hazard has changed.
- Verify that no obvious physical damage or condition exists that might prevent system operation.

**Protection Panel**

- Verify that all warning lamps and the audible alarm are operational by pressing the “TEST/RESET” button.

**Manual Activation Switch**

- Verify that the tamper seal is intact and access to the switch is unobstructed.

**Fire Detectors**

- Optical
  - Verify that the status lamp on the detector face is on solid green.
  - Verify that nothing is blocking the detector’s field of view.
  - Verify that the windows on the face of the detector are free of excess contamination (dirt, oil, grease, etc.) – if necessary, clean using a water soaked non-abrasive towel.
- Linear Thermal
  - Verify that there is no obvious physical damage and that the unit is free of excess contamination (dirt, oil, grease, etc) – if necessary, clean using a water soaked non-abrasive towel.
  - Verify that mounting is secure and taught.

**Electrical Harness**

- Verify that electrical connectors and electrical wiring have no visible damage and all connectors are securely seated.

## Section 23: ACCESSORIES

---

### Extinguisher & Distribution System

- Verify that the extinguisher pressure gauge pointer is in the green arc at room temperature.
- Verify that distribution piping and nozzles are intact and unobstructed and that nozzle blow-off caps are in place.

### **EVERY 18000 MILES OR SEMI-ANNUALLY** (whichever comes first)

- Perform a comprehensive fire system test using a Kidde Dual Spectrum System Test Set (Optical Test Kit P/N 420871-2).
- Service the extinguisher in accordance with KDS Document 160296, "KDS Pre-Engineered Fire Suppression System: Installation, Operation and Maintenance Manual".

### **EVERY SIX YEARS**

- Have the fire extinguisher rebuilt by a qualified fire protection equipment company familiar with Kidde Dual Spectrum equipment and in accordance with KDS Document 160296, "KDS Pre-Engineered Fire Suppression System: Installation, Operation and Maintenance Manual". Rebuilt shall include actuator, o-ring seals and dry chemical replacement.

### **EVERY TWELVE YEARS**

- Have the Extinguisher cylinder hydrostatically tested by a qualified fire protection equipment company familiar with Kidde Dual Spectrum equipment and in accordance with KDS Document 160296, "KDS Pre-Engineered Fire Suppression System: Installation, Operation and Maintenance Manual".

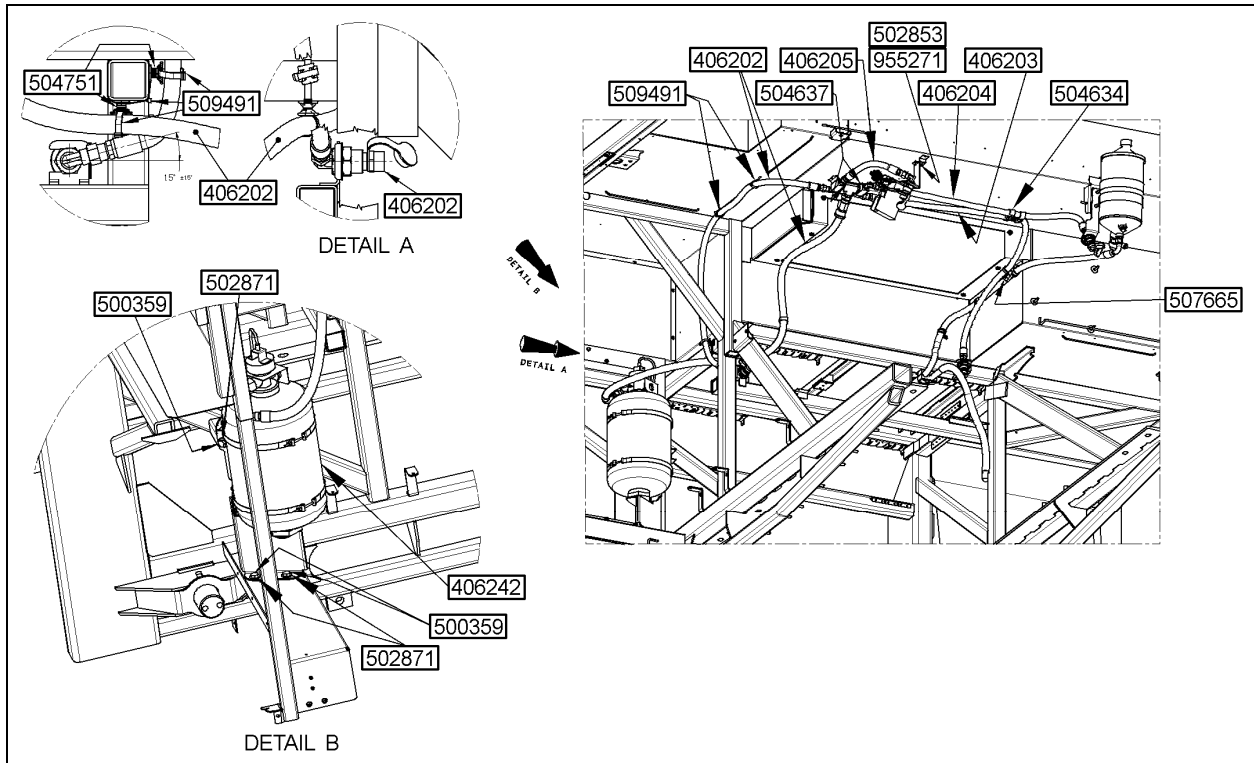

FIGURE 16: W5 FIRE EXTINGUISHER INSTALLATION

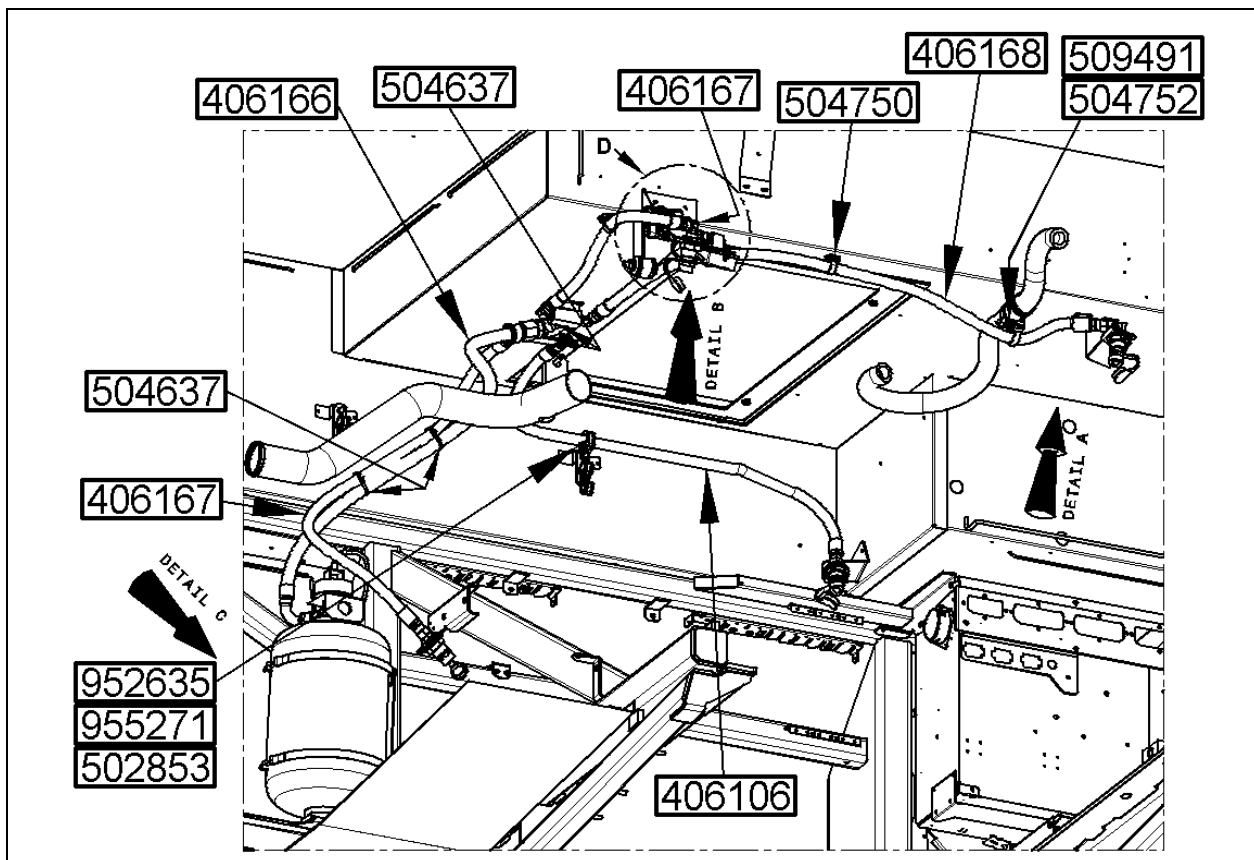

FIGURE 17: WE FIRE EXTINGUISHER INSTALLATION

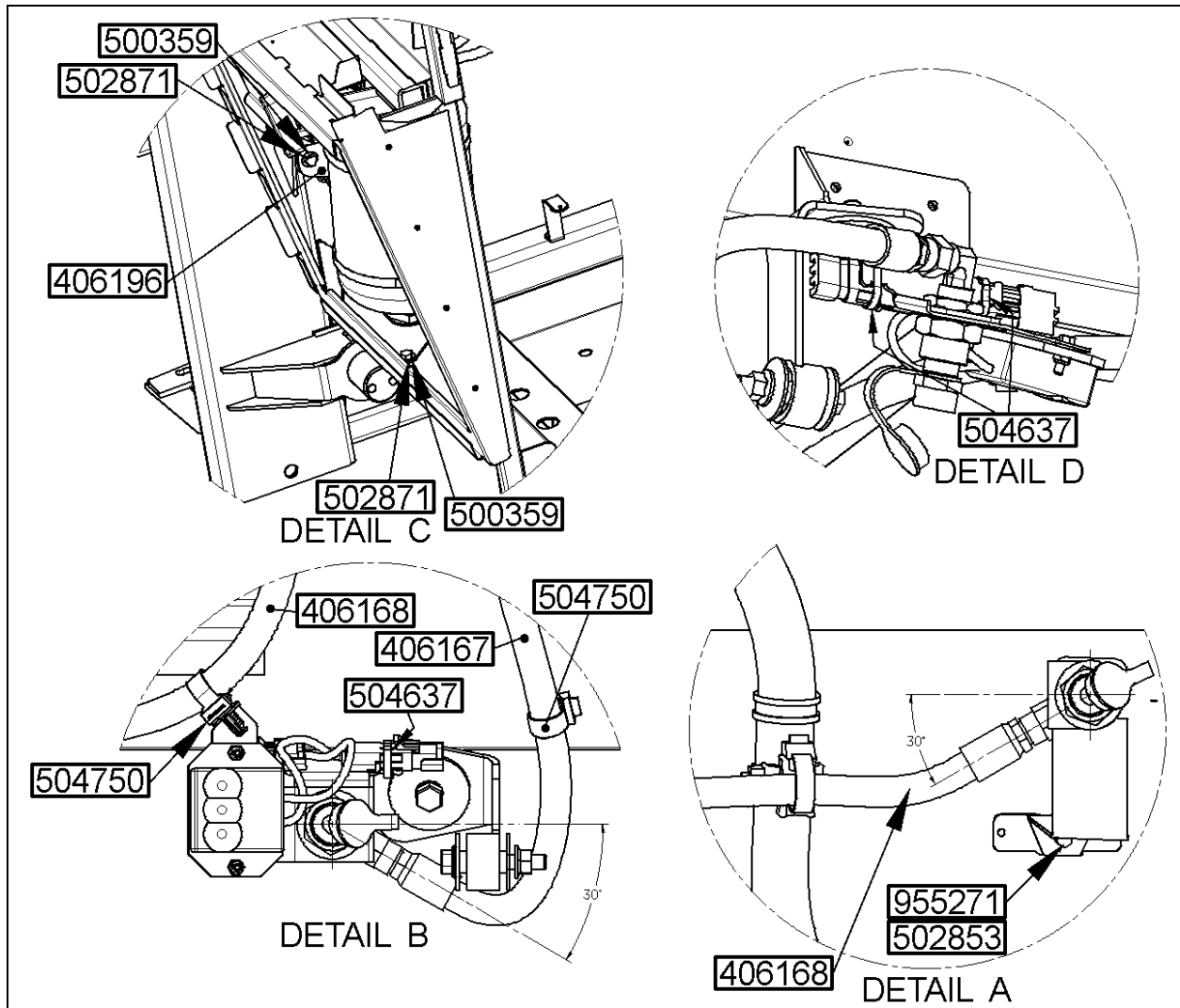

FIGURE 18: WE NOZZLE BRACKETS IDENTIFICATION AND INSTALLATION

**10. SPECIFICATIONS**

**HUBODOMETER (US model: miles)**

Make..... Stemco  
 Prevost number ..... 650002

**HUBODOMETER (Canada model: km)**

Make..... Stemco  
 Prevost number ..... 650117

**AIR HORN**

Make..... Allied Signal Inc.  
 Prevost number ..... 640093

**AIR HORN VALVE**

Make..... Allied Signal Inc.  
 Prevost number ..... 640128



**WINDSHIELD WIPER MOTOR**

Make..... BOSCH  
Prevost number ..... 800328

**WIPER (BLADE)**

Make..... BOSCH  
Prevost number ..... 800329

**WIPER ARM**

Make..... BOSCH  
Prevost number ..... 800331