

SECTION 24: LUBRICATION & SERVICING

CONTENTS

1	LUBRICATION	2
2	LUBRICATION AND SERVICE SCHEDULE	2
2.1	FLEXIBLE HOSE MAINTENANCE.....	2
2.1.1	<i>HOSE INSPECTION</i>	2
2.1.2	<i>LEAKS</i>	2
2.1.3	<i>SERVICE LIFE</i>	2
2.2	FLUIDS AND LUBRICANTS SPECIFICATIONS.....	8
2.3	LUBRICATION AND SERVICING SCHEDULES	8

ILLUSTRATIONS

FIGURE 1:	LUBRICATION AND SERVICING POINTS (I-BEAM FRONT AXLE SHOWN) TYPICAL	4
FIGURE 2:	LUBRICATION AND SERVICING POINTS – HVAC UNIT	6
FIGURE 3:	LUBRICATION AND SERVICING POINTS - INDEPENDENT FRONT SUSPENSION VEHICLES (TYPICAL)	7

1 LUBRICATION

The efficiency and life expectancy of mechanical equipment is largely dependent on proper lubrication and servicing. All mechanical components rely on a lubricating film between moving parts to reduce friction, prevent wear and oxidation. Proper lubrication also helps cool the parts and keep dirt particles away from mating surfaces. Efficient lubrication depends upon using the right type of lubricant, at specified intervals and by filling to correct capacities. Past experience shows that many service problems can be traced to an improper lubricant or to incorrect lubrication procedures.

A comprehensive maintenance and lubrication program is important to ensure the long service life this vehicle was designed for and to avoid costly repairs and associated downtime caused by premature part failure.

A lubrication schedule is included in this section to give the location of key service points on the vehicle as well as the lubricant specifications for each component to be serviced. Specific instructions on how to check and service different components are covered in their respective sections in this maintenance manual.

The recommended lubrication intervals are based on normal operating conditions and mileage accumulation.

Shorten the intervals if your vehicle operates in more severe conditions. Severe conditions include heavy towing, high vehicle weight or operation in mountainous areas. Some parts and equipment referred to in this section may not be installed on your vehicle. Check your vehicle's "Coach Final Record" for equipment list.

Dispose of used lubricants and filters in an environmentally safe manner, according to federal and/or local recommendations.

2 LUBRICATION AND SERVICE SCHEDULE

Following this service schedule is the most economical and easiest way to ensure your vehicle performs at its best, safest and longest. Also, unscheduled maintenance will be minimized since inspection should expose potential problems before they become major ones.

2.1 FLEXIBLE HOSE MAINTENANCE

The performance of engine and equipment are greatly related to the ability of flexible hoses to supply lubricating oil, air, coolant, and fuel oil. Maintenance of hoses is an important step to ensure efficient, economical, and safe operation of the engine and related equipment.

2.1.1 Hose Inspection

Check hoses daily as part of the pre-starting inspection. Examine hose for leaks, and check all fittings, clamps, and ties carefully. Ensure that hoses are not resting on or touching shafts, couplings, heated surfaces including exhaust manifolds, any sharp edges, or other obviously damaging areas. Since all machinery vibrates and moves to a certain extent, clamps and ties can fatigue with time. To ensure proper support, inspect fasteners frequently and tighten or replace them as necessary.



WARNING

Personal injury and property damage may result from fire caused by leaking flammable fluids.

2.1.2 Leaks

Hoses have a limited service life. Thoroughly inspect hoses annually. Look for surface damage or indications of twisted, worn, crimped, cracked or leaking lines. Replace damaged hoses immediately.

Hoses should be replaced during major overhaul or after a maximum of seven years service. Be certain that replacement hoses match the original equipment manufacturer's specifications.

2.1.3 Service life

The limited service life of a hose is determined by the temperature and pressure of the gas or fluid within it, the time in service, its installation, the ambient temperatures, amount of flexing, and the vibration it is subjected to. With this in mind, it is recommended that all hoses be thoroughly inspected at least every 500 operating hours or after 15,000 miles (24 000 km). Look for surface damage or indications of damaged, twisted, worn, crimped, brittle, cracked, or leaking lines. Hoses having a worn

outer surface or hoses with a damaged metal reinforcement should be considered unfit for further service.

It is also recommended that all hoses in this vehicle be replaced during major overhaul and/or after a maximum of five service years. Quality of replacement hose assemblies should always be equal to or superior to those supplied by the Original Equipment Manufacturer.

Section 24: LUBRICATION & SERVICING

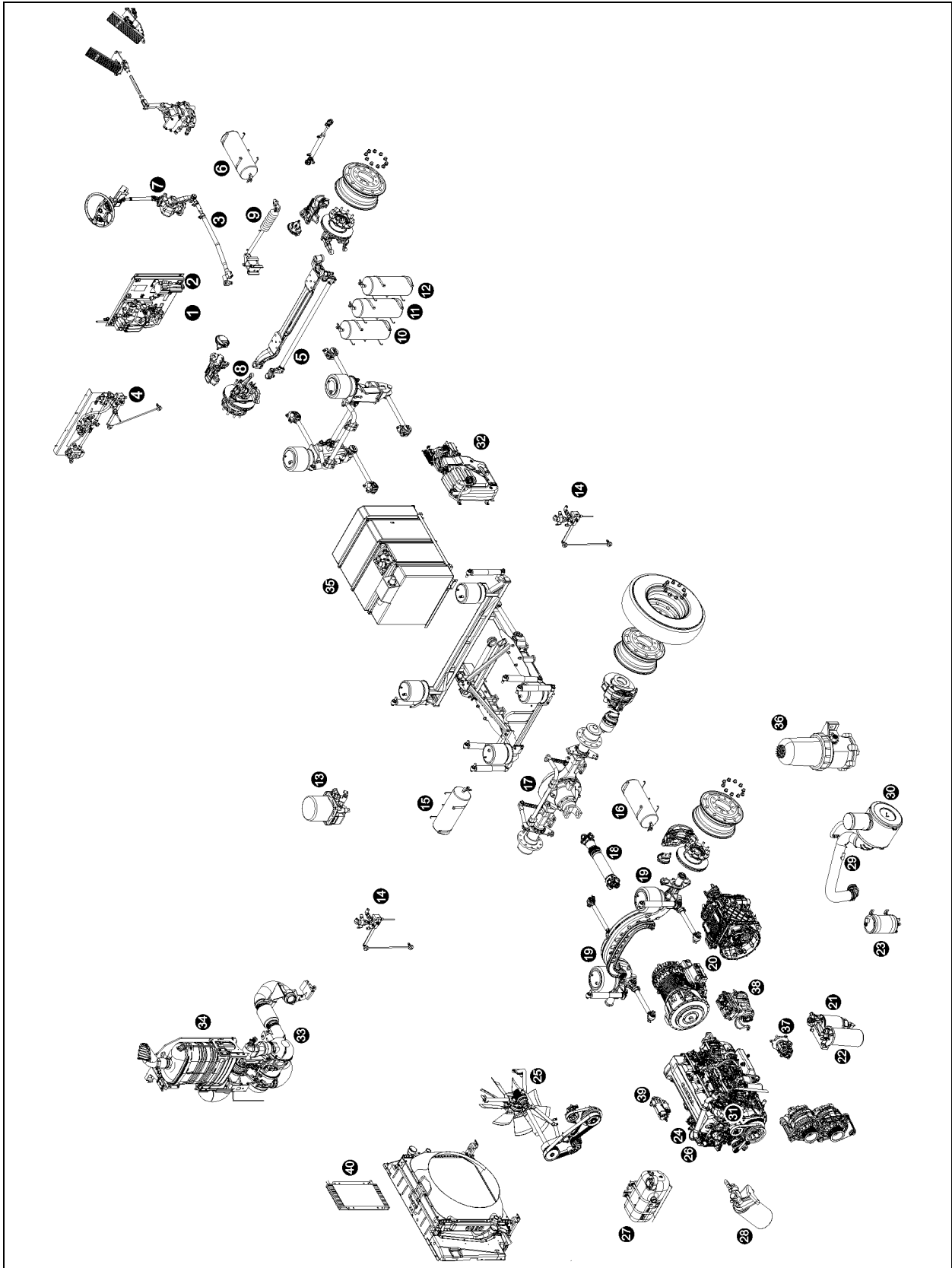

FIGURE 1: LUBRICATION AND SERVICING POINTS (I-BEAM FRONT AXLE SHOWN) TYPICAL

Section 24: LUBRICATION & SERVICING

1	Accessories air tank drain cock	21	Primary fuel filter
2	Accessories air filter	22	Secondary fuel filter
3	Steering drag link	23	Power steering fluid tank
4	Height control valve (front)	24	Engine oil filter
5	Steering tie rod	25	Cooling fan gearbox
6	Accessories air tank	26	Allison transmission oil dipstick
7	Steering column U-joints	27	Engine coolant surge tank
8	Steering knuckle pins	28	Coolant filter & conditioner
9	Steering damper cylinder	29	Engine air filter restriction indicator
10	Emergency / parking brake overrule tank	30	Engine air filter
11	Secondary air tank	31	Engine oil dipstick and filler tube
12	Kneeling air tank	32	DEF tank
13	Air dryer	33	Diesel particulate filter
14	Height control valve (rear)	34	SCR catalytic converter
15	Wet air tank	35	Diesel fuel tank
16	Primary air tank	36	Davco Fuel Pro 382 fuel filter
17	Differential	37	Power steering pump
18	Propeller shaft	38	Air compressor
19	Tag axle lever pivot	39	Starter
20	Transmission	40	Fuel cooler

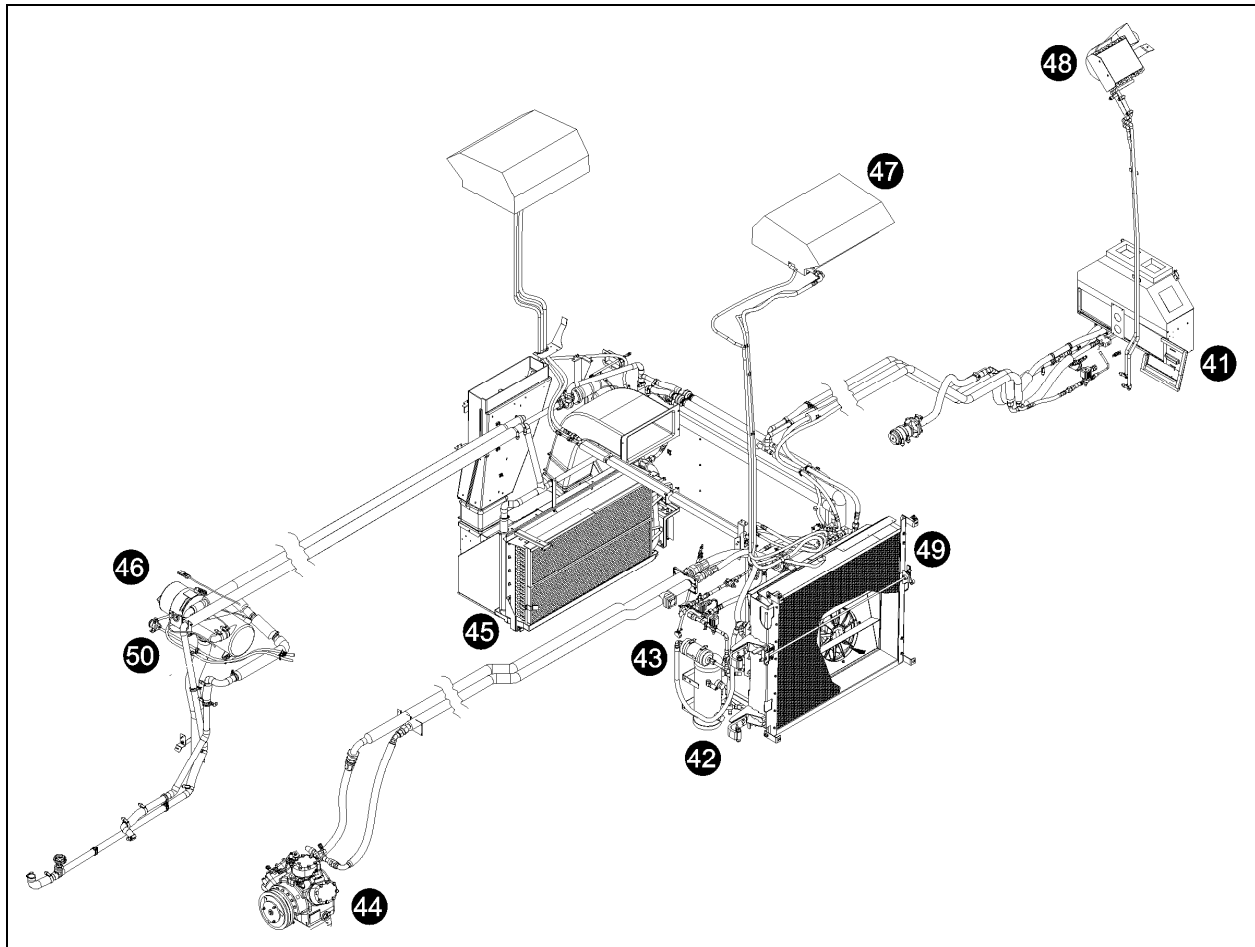

FIGURE 2: LUBRICATION AND SERVICING POINTS – HVAC UNIT

- | | | | |
|----|------------------------------------|----|---|
| 41 | HVAC air filter – driver's unit | 46 | Coolant preheater |
| 42 | A/C receiver tank | 47 | A/C system – passenger's overhead console |
| 43 | Refrigerant moisture indicator | 48 | Upper windshield defrost unit |
| 44 | A/C compressor | 49 | Condenser coil |
| 45 | HVAC air filter – passenger's unit | 50 | Preheater fuel filter |

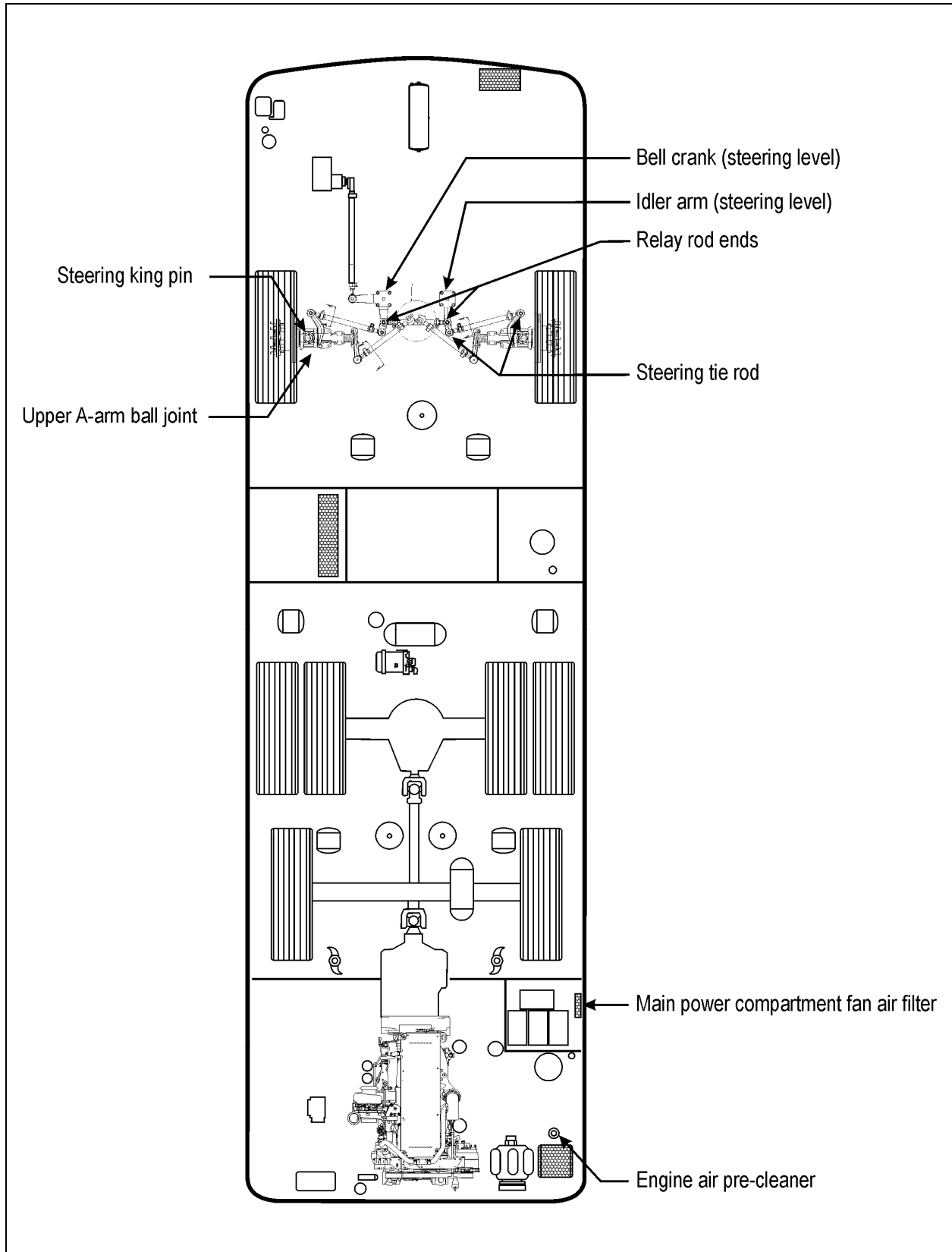

FIGURE 3: LUBRICATION AND SERVICING POINTS - INDEPENDENT FRONT SUSPENSION VEHICLES (TYPICAL)

Section 24: LUBRICATION & SERVICING

2.2 FLUIDS AND LUBRICANTS SPECIFICATIONS

FLUIDS & LUBRICANTS		
REF	DESCRIPTION	SPECIFICATIONS
A	Engine Oil	VOLVO D13 SAE Viscosity Grade: 10W-30 API Classification CJ-4 meeting Volvo specification VDS-4 and EO-O Premium Plus
B	Power Steering Oil	Automatic Transmission Oil, Dexron-III
C	Engine Coolant	VOLVO D13 Texaco or Chevron Extended Life Coolant (ELC) 50% antifreeze/water solution is normally used
D	A/C Compressor Oil	Central HVAC system: Polyolester oil, HFC 134a compatible; Castrol SW-68 (POE) or equivalent Small HVAC system: PAG oil
E	Differential Oil	Multigrade gear oil meeting MIL-L-2105-D: 85W140. If temperature drops below 10°F (-12°C), 80W90 should be used. Below -15°F (-26°C), 75W90 should be used. (In extreme conditions or for better performance, full synthetic gear oil can be used)
F	Differential Oil (Full Synthetic)	Multigrade gear oil meeting MIL-L-2105-D: 85W140. If temperature drops below 10°F (-12°C), 80W90 should be used. Below -15°F (-26°C), 75W90 should be used.
G	Cooling Fan Gearbox Oil	Synthetic gear lubricant 75W-90 (refer to Linnig bulletin 142.377 for the list of approved oils)
H	Allison Automatic Transmission Oil	Castrol TranSynd™ Synthetic Transmission Fluid for Allison or TES 295 approved equivalent
I	Allison Automatic Transmission Oil	Dexron-VI® or approved equivalent 1 Schedule 1 TES-389 fluids;
J	Volvo I-Shift Transmission	Castrol Syntrans Grade SAE 75W-85 synthetic oil
K	Multi Purpose Grease	Good quality lithium-base grease: NLGI No.2 Grade is suitable for most temperatures NLGI No.1 Grade is suitable for extremely low temperatures
L	Multi Purpose Grease	Molykote longterm 2/78 grease

2.3 LUBRICATION AND SERVICING SCHEDULES

For lubrication and servicing schedule, refer to the two following tables.

<i>IMPORTANT NOTE</i>
<i>Refer to the manufacturers documentation included in this maintenance manual for specific manufacturer's maintenance requirements.</i>

LUBRICATION AND SERVICING SCHEDULE		PROCEED TO MAINTENANCE OPERATION <u>EVERY</u> ¹											Lubricant / Fluid ²				
		Item	Month	6 250 mi / 10 000 km	12 500 mi / 20 000 km	31 250 mi / 50 000 km	50 000 mi / 80 000 km	100 000 mi / 160 000 km	106 000 mi / 170 000 km	125 000 mi / 200 000 km	150 000 mi / 240 000 km	185 000 mi / 300 000 km		250 000 mi / 400 000 km	300 000 mi / 500 000 km	500 000 mi / 800 000 km	600 000 mi / 960 000 km
GENERAL																	
1	Flexible hoses – thoroughly inspect all hoses	12				●											
01 ENGINE																	
1	Engine oil & filter – heavy ³ operation condition, change every 35 000mi / 60 000km	24															A
2	Engine oil & filter – normal ³ operation condition, change every 45 000mi / 75 000km	24															A
3	Air cleaner – replace filter element when indicated by restriction indicator or after a maximum of 2 years	30	24														
4	Drive belt (water pump) – inspect for cracks or frayed material, replace belt that display obvious wear or defects	12			●												
5	Valves & injectors – initial adjustment	24	12							●							
6	Valves & injectors – check & adjust	24	24											●			
7	Drive belt tensioners (water pump, fan, alternators) – remove belts, check for noisy bearings, play, bushing play													●			
03 FUEL																	
1	Primary & secondary fuel filters – replace at every engine oil change	21															
		22															
2	Preheater fuel filter – change	50	12			●											
04 EXHAUST AND AFTERTREATMENT SYSTEM																	
1	Diffuser assembly, rain cap & drain tube – check proper functioning, clean	34	12														
2	DEF pump filter – replace	32	36							●							
3	DEF tank – drain, clean with water, clean filler neck strainer	32	12							●							
4	Aftertreatment Hydrocarbon Injector (AHI) nuzzle – replace									●							
5	DPF filter – either clean or replace filter cartridge every 400 000mi / 650 000km																
05 COOLING																	
1	Coolant surge tank – test coolant solution	27	12	●													
2	Radiator fan gearbox – check oil level	25	6	●													
3	Radiator fan drive belt – inspect for cracks or frayed material, replace belt that display obvious wear or defects		12		●												
4	Radiator – inspect exterior core & clean with low pressure water jet if necessary								●								
5	Radiator fan gearbox – change oil	25	12						●								G
6	Coolant filter – change at every engine oil change (Chemical Additive Filter must be used with Fully Formulated Coolant)	28															
7	Coolant filter – change (Long-Life Filter without additives to be used with Extended Life Coolant)	28	12							●							

¹ Proceed to maintenance operation at mileage indicated on odometer or specified number of month, whichever comes first.

² See paragraph 2.2 of this section for lubricant specifications.

³ Normal = fuel consumption more than 6mpg (less than 39 L/100km); Heavy = fuel consumption between 4.7mpg and 6mpg (between 39 L/100km and 50 L/100km).

Section 24: LUBRICATION & SERVICING

LUBRICATION AND SERVICING SCHEDULE H3 Series coaches X3 Series coaches H3 VIP commercial use X3 VIP commercial use		PROCEED TO MAINTENANCE OPERATION <u>EVERY</u> ¹											Lubricant / Fluid ²						
		Item	Month	6 250 mi / 10 000 km	12 500 mi / 20 000 km	31 250 mi / 50 000 km	50 000 mi / 80 000 km	100 000 mi / 160 000 km	106 000 mi / 170 000 km	125 000 mi / 200 000 km	150 000 mi / 240 000 km	185 000 mi / 300 000 km		250 000 mi / 400 000 km	300 000 mi / 500 000 km	500 000 mi / 800 000 km	600 000 mi / 960 000 km		
8	Cooling system – drain, flush & refill (fully formulated coolant)	27	24														●		
9	Cooling system – drain, flush & refill (extended life coolant) every 750 000mi / 1 200 000km	27	96															C	
06 ELECTRICAL																			
1	Power cables inspection – Perform MI15-24		3																
2	Battery terminals – clean & coat terminals		12																
3	HD10 Bosch alternators drive belt – inspect for cracks or frayed material, replace belt that display obvious wear or defects		12			●													
4	HD10 Bosch alternators brushes – check & replace brushes if needed							●											
07 TRANSMISSION ⁴																			
1	Allison transmission filled with TES389 approved fluid and Prognostics mode disabled – change transmission fluid, Main & Lube filter (Refer to TABLE 1 in Section 07: Transmission for Main & Lube filter change intervals)	20																I	
2	Allison transmission filled with TranSynd or TES295 synthetic fluid only, no mixture^{5,6} and Prognostics mode disabled – change transmission fluid, Main & Lube filter (Refer to TABLE 2 in Section 07: Transmission for Main & Lube filter change intervals)	20																H	
3	Allison transmission filled with TranSynd or TES295 synthetic fluid only, no mixture^{5,6} and Prognostics mode enabled – change fluid & filters when indicated by TRANSMISSION SERVICE indicator or 60 month whichever occurs first. In addition, change filters with every fluid change	20	60															H	
4	Allison transmission filled with TES389 approved fluid with Prognostics mode enabled^{5,6} – change fluid & filters when indicated by TRANSMISSION SERVICE indicator or 24 month whichever occurs first. In addition, change filters with every fluid change.	20	24															H	
5	Transmission oil cooler, replace unit if vehicle is equipped with transmission retarder		24																
6	Volvo I-Shift Transmission not filled with Castrol Syntrans SAE 75W85, change fluid & filter	20	36														●		
7	Volvo I-Shift Transmission filled with Castrol Syntrans SAE 75W85 (extended oil drain), change fluid & filter	20	60															●	J
09 PROPELLER SHAFT																			
1	Perform Spicer’s Driveshaft Assembly Inspection Procedures	18				●													
2	Grease one fitting on each universal joint	18	6					●										K	
11 REAR AXLES																			
1	Drive axle – check differential oil level, add if necessary every 25 000 mi	17	6															E	
2	Tag axle lever pivot – grease one fitting on each pivot	19	6	●														K	

⁴ In the absence of a fluid analysis program, the fluid change interval listed in Table 1, Table 2 & Table 3 should be used. Change filters according to Table 1, Table 2 & Table 3 even if a fluid analysis shows that the fluid doesn’t need to be changed.

⁵ When the transmission contains a mixture of fluids (defined as the quantity of non-TranSynd or non- TES 295 fluid remaining in the transmission after a fluid change combined with the quantity of TranSynd or TES295 required to fill the transmission to the proper level), perform the fluid and filter change according to the TES389 intervals.

⁶ Extended TranSynd or TES 295 fluid and filter change intervals are only allowed with Allison High-Capacity filters.

LUBRICATION AND SERVICING SCHEDULE		PROCEED TO MAINTENANCE OPERATION <u>EVERY</u> ¹											Lubricant / Fluid ²				
		Item	Month	6 250 mi / 10 000 km	12 500 mi / 20 000 km	31 250 mi / 50 000 km	50 000 mi / 80 000 km	100 000 mi / 160 000 km	106 000 mi / 170 000 km	125 000 mi / 200 000 km	150 000 mi / 240 000 km	185 000 mi / 300 000 km		250 000 mi / 400 000 km	300 000 mi / 500 000 km	500 000 mi / 800 000 km	600 000 mi / 960 000 km
H3 Series coaches																	
X3 Series coaches																	
H3 VIP commercial use																	
X3 VIP commercial use																	
3	Drive axle – change differential oil, clean breather	17	12					●									F
4	Drive axle – change differential oil, clean breather (with full synthetic oil)	17	48										●				F
12 BRAKE & AIR SYSTEM																	
1	Check proper functioning of the adjuster, check caliper running clearance, check caliper movement along guide pins, check sealing elements, at every pad replacements or once a year whichever comes first		12														
2	ABS & Electronic Stability Control systems – check proper functioning		12														
3	Air tanks – drain water from all tanks		6	●													
4	Brake pads – check pad wear indicator. Visually check condition of the slack adjuster cap & guide pin covers			●													
5	Accessories air filter – change filter element	2	24					●									
6	Air dryer – change cartridge	13	24					●									
13 WHEELS, HUBS & TIRES																	
1	Unitized hub bearing, front and tag axle – inspect, check end play. Refer to See Dana Spicer Maintenance Manual Model NDS Axle Range	8	12		●												
14 STEERING																	
1	Drag link end ball joints – inspect for corrosion	3	12														
2	Tie rod end ball joints – inspect for corrosion	5	12														
3	Steering knuckle (king) pins – grease two fittings per knuckle	8	6	●													K
4	Steering knuckle (king) pins – check play	8	6		●												
5	X3 Series only: Drag link ends – clean and grease two fittings at each end		6	●													
6	X3 Series only: Idler arm – grease fitting		6	●													
7	X3 Series only: Bell crank – grease fitting		6	●													
8	X3 Series only: Relay rod ends – grease one fitting at each end		6	●													
9	Steering tie rod ends – clean & grease one fitting at each end	5	6	●													K
10	Steering damper cylinder – grease one fitting at rod end	9	6	●													K
11	Power steering reservoir filter cartridge and fluid – replace	23	12			●											B
18 BODY																	
1	Structure inspection for corrosion – Perform MI15-18 every 5 years for normal duty vehicles and normal environment operation																
2	Structure inspection for corrosion – Perform MI15-18, every 2 years starting from the 5 th year in service for severe duty vehicles and harsh environment operation																
22 HEATING & AIR CONDITIONING																	
1	A/C compressor – check oil level, add if necessary	44	6	●													D
2	A/C compressor – empty shaft seal oil collection tube	44	6	●													
3	A/C receiver tank – check refrigerant level, add if necessary	42	6	●													
4	Refrigerant moisture indicator – check filter dryer unit, replace according to moisture indicator	43	6	●													
5	Evaporator compartment return air filters (2x) – clean or replace	45	6		●												
6	X3 Series only. Evaporator compartment door fresh air intake filter – clean or replace		6	●													

Section 24: LUBRICATION & SERVICING

LUBRICATION AND SERVICING SCHEDULE H3 Series coaches X3 Series coaches H3 VIP commercial use X3 VIP commercial use		PROCEED TO MAINTENANCE OPERATION <u>EVERY</u> ¹											Lubricant / Fluid ²				
		Item	Month	6 250 mi / 10 000 km	12 500 mi / 20 000 km	31 250 mi / 50 000 km	50 000 mi / 80 000 km	100 000 mi / 160 000 km	106 000 mi / 170 000 km	125 000 mi / 200 000 km	150 000 mi / 240 000 km	185 000 mi / 300 000 km		250 000 mi / 400 000 km	300 000 mi / 500 000 km	500 000 mi / 800 000 km	600 000 mi / 960 000 km
7	Parcel rack fans air filter – clean or replace	47	6	●													
8	Driver's HVAC unit return air filter – clean or replace	41	6	●													
9	Evaporator compartment & driver's HVAC units – clean heater core with low air pressure		12														
10	Evaporator compartment & driver's HVAC units – clean evaporator core with low air pressure		12														
11	Evaporator compartment & driver's HVAC units – clean condenser core with low air pressure		12														
12	A/C compressor drive belt – check tension, inspect for cracks or frayed material		12		●												
13	Recommended maintenance ⁷ : A/C compressor – change oil, clean oil filter		36														
23 ACCESSORIES																	
1	AFSS extinguisher tank – Replace or rebuild		72														
2	AFSS extinguisher tank – test hydrostatically		144														

CHANGE LOG - LUBRICATION AND SERVICING SCHEDULE		DATE
A red stripe in the left margin of the schedule highlights the latest changes		
1	ADDED: 04 EXHAUST & AFTERTREATMENT SYSTEM - Diffuser assembly, rain cap & drain tube – check proper functioning, clean	Sept.04, 2014
2	UPDATE: 01 ENGINE – Engine oil & filter change heavy operation, was 25 000mi, changed to 35 000mi	Jan.08, 2015
3	UPDATE: 01 ENGINE – Engine oil & filter change normal operation, was 35 000mi, changed to 45 000mi	Jan.08, 2015
4	UPDATE: 01 ENGINE – Initial valve adjustment, was 125 000mi, changed to 150 000mi	Jan.08, 2015
5	UPDATE: 01 ENGINE – Valve check & adjustment, was 250 000mi, changed to 300 000mi	Jan.08, 2015
6	ADDED: 01 ENGINE – Drive belt tensioners inspection	Jan.08, 2015
7	UPDATE: 04 EXHAUST & AFTERTREATMENT SYSTEM – DEF tank cleaning, was 185 000mi, changed to 150 000mi to match with DEF pump filter change	Jan.08, 2015
8	UPDATE: 04 EXHAUST & AFTERTREATMENT SYSTEM – DPF filter cleaning or replacement, was 250 000mi, changed to 400 000mi	Jan.08, 2015
9	UPDATE: 05 COOLING – Cooling system with extended life coolant, drain flush & refill, was 650 000mi, changed to 750 000mi or 96 months	Jan.08, 2015
10	ADDED: 22 HEATING & AIR CONDITIONING – Recommended maintenance: A/C compressor – change oil, clean oil filter	Jan.08, 2015
11	ADDED: 23 ACCESSORIES – AFSS extinguisher tank – Replace or rebuild	Mar.02, 2015
12	ADDED: 23 ACCESSORIES – AFSS extinguisher tank – Hydrostatic test	Mar.02, 2015
13	ADDED: 18 BODY – Inspection for corrosion	May 27, 2015
14	ADDED: 06 ELECTRICAL – Power cables inspection	May 27, 2015
15	UPDATE: 12 BRAKE & AIR SYSTEM – Air tanks drainage, was 12 months, changed to 6 months	May 27, 2015
16	ADDED: 04 EXHAUST AND AFTERTREATMENT SYSTEM – AHI nuzzle replacement	Aug.12, 2015

⁷ Compressor oil change is not necessarily required for A/C systems which are operated in normal fashion, however oil does wear down, therefore it is strongly recommended to change oil approximately every 3 years (10000-12000 operating hours)



INTENTIONALLY LEFT BLANK

Section 24: LUBRICATION & SERVICING

LUBRICATION AND SERVICING SCHEDULE H3-45 VIP & X3-45 VIP MOTORHOMES (Private Use)	ITEM	EVERY (months)	LUBRICANT / FLUID ⁸
GENERAL			
All flexible hoses – inspect		12	
H3 VIP Series only: Main power compartment fan air filter – inspect		12	
01 ENGINE			
Engine oil and filters – replace	24	12	A
Air cleaner – replace filter element	30	24	
Engine mounted alternators & house alternator(s) – replace drive belts and intermediary drive belts		24	
Coolant pump drive belt – replace		24	
Valves and injectors – initial adjustment: after 2 500 hours or 36 months whichever occurs first	24	36	
Valves and injectors – check and adjust: every 5 000 hours or 72 months whichever occurs first	24	72	
03 FUEL			
Primary fuel filter & secondary fuel filter – change at every engine oil change	21, 22		
04 EXHAUST AND AFTERTREATMENT SYSTEM			
DPF filter – either clean or replace filter cartridge after 4 500 hours	33		
Aftertreatment Hydrocarbon Injector (AHI) nuzzle – replace after 4 500 hours			
DEF tank – drain and clean with water, clean filler neck strainer	32	12	
Diffuser assembly, rain cap & drain tube – check proper functioning, clean	34	24	
DEF pump – replace filter element	32	36	
05 COOLING			
Radiator fan gearbox – check oil level, add if required	25	12	G
Coolant surge tank – test coolant solution	27	12	
Coolant filter – change (long life filter with extended life coolant)	28	12	
Radiator fan drive belt – inspect for cracks or frayed material, replace if required	25	24	
Radiator fan gearbox – change oil	25	48	G
Cooling system – drain, flush & refill (with extended life coolant)	27	96	C
06 ELECTRICAL			
Battery terminals – clean and coat terminals		12	
Power cables inspection – Perform MI15-24		24	
Bosch HD10 alternator brushes – check and replace if required		48	
07 TRANSMISSION⁹			
Filled with TES389 approved fluid, with Prognostics mode disabled – see TABLE 1 in <i>Section 07: Transmission</i> for fluid and filter change	20		I
Filled with TranSynd or TES295 approved fluid only, no mixture ¹⁰ , with Prognostics mode disabled – See TABLE 2 in <i>Section 07: Transmission</i> for fluid and filter change	20		H
Filled with TranSynd or TES295 approved fluid only, no mixture with Prognostics mode enabled ¹¹ - Change fluid & filters when indicated by TRANSMISSION SERVICE indicator or 60 month whichever occurs first. In addition, change filters with every fluid change.	20	60	H

⁸ See paragraph 2.2 of this section for lubricant specifications.

⁹ In the absence of a fluid analysis program, the fluid change interval listed in Table 1, Table 1 & Table 3 should be used. Change filters according to Table 1, Table 2 & Table 3 even if a fluid analysis shows that the fluid doesn't need to be changed.

¹⁰ When the transmission contains a mixture of fluids (defined as the quantity of non-TranSynd/ non- TES 295 fluid remaining in the transmission after a fluid change combined with the quantity of TranSynd or TES295 required to fill the transmission to the proper level), perform the fluid and filter change according to the TES389 intervals.

LUBRICATION AND SERVICING SCHEDULE			
H3-45 VIP & X3-45 VIP MOTORHOMES (Private Use)			
	ITEM	EVERY (months)	LUBRICANT / FLUID⁸
Filled with TES389 approved fluid only, no mixture with Prognostics mode enabled – Change fluid & filters when indicated by TRANSMISSION SERVICE indicator or 24 month whichever occurs first. In addition, change filters with every fluid change.	20	24	H
09 PROPELLER SHAFT			
Universal joint – grease on fitting on each universal joint	18	12	K
11 REAR AXLE			
Drive axle – check differential oil level, add if necessary	17	12	E
Drive axle – change differential oil, clean breathers	17	12	E
Tag axle lever pivot, grease one fitting on each pivot	19	12	K
Drive axle – change differential oil, clean breathers (with full synthetic oil)	17	48	F
12 BRAKE & AIR			
Air tanks – drain water from all tanks		12	
Brake pads ¹² – check pad wear indicator		12	
Check caliper running clearance, check condition of caliper cover, slack adjuster cap and guide pin assembly covers		12	
Abs & electronic stability control systems – check proper functioning		12	
Air dryer – change cartridge	13	24	
Accessories air filter – change filter element	2	48	
13 WHEELS, HUBS & TIRES			
Unitized hub bearing, front and tag axle – inspect, check end play. Refer to See Dana Spicer Maintenance Manual Model NDS Axle Range	8	12	
14 STEERING			
Steering knuckle (king) pins – check play	8	12	
Steering knuckle (king) pins – grease two fittings per knuckle	8	12	K
Tie rod ends – clean and grease one fitting at each end		12	K
Drag link ends – clean and grease two fittings at each end		12	K
Tie rod end & drag link end ball joints – inspect for corrosion		12	
Power steering reservoir filter cartridge and fluid – replace	23	12	B
Idler arm – grease fitting		12	K
Bell crank – grease fitting		12	K
Relay rod ends – grease one fitting at each end		12	K
16 SUSPENSION			
Independent front suspension upper a-arm ball joint – grease fittings		12	L
22 HEATING & AIR CONDITIONING			
A/C compressor – check oil and replenish if required	44	12	D
A/C compressor – empty shaft seal oil collection tube (Bitzer A/C compressor)	42	12	
A/C receiver tank – check refrigerant level, add if required	42	12	
Refrigerant moisture indicator – check filter dryer unit, replace according to moisture indicator	43	12	
HVAC air filters – clean all filter elements	41, 45	12	

¹¹ Extended TranSynd or TES295 fluid and filter change intervals are only allowed with Allison High-Capacity filters.

¹² At each pad replacement, check slack adjuster operation, perform caliper slide check and inspect visually all sealing elements & caps.

Section 24: LUBRICATION & SERVICING

LUBRICATION AND SERVICING SCHEDULE H3-45 VIP & X3-45 VIP MOTORHOMES (Private Use)		ITEM	EVERY (months)	LUBRICANT / FLUID ⁸
A/C compressor drive belt – check tension, inspect for cracks or frayed material, replace if required			24	

CHANGE LOG - LUBRICATION AND SERVICING SCHEDULE A red stripe in the left margin of the schedule highlights the latest changes		DATE
1	ADDED: 04 EXHAUST & AFTERTREATMENT SYSTEM - Diffuser assembly, rain cap & drain tube – check proper functioning, clean	Sept.04, 2014
2	05 COOLING – Cooling system with extended life coolant, drain flush & refill, was 48 months, changed to 96 months	Jan.08, 2015
3	ADDED: 06 ELECTRICAL – Power cables inspection	May 27, 2015
4	ADDED: 04 EXHAUST AND AFTERTREATMENT SYSTEM – AHI nuzzle replacement	Aug.12, 2015
5		
6		
7		
8		
9		
10		