

## SECTION 2 COACH EXTERIOR

X3-45 COMMUTER EXTERIOR VIEWS .....	2
ENGINE COMPARTMENT OVERVIEW .....	3
ENGINE COMPARTMENT CURBSIDE DOOR .....	4
ENGINE COMPARTMENT REAR DOOR.....	4
EXHAUST AFTERTREATMENT SYSTEM ACCESS DOOR.....	5
ENGINE RADIATOR DOOR .....	6
SCR CONVERTER ACCESS DOOR .....	6
CONDENSER COMPARTMENT (A/C).....	7
EVAPORATOR COMPARTMENT.....	8
COOLANT HEATER COMPARTMENT .....	9
REAR FENDERS.....	9
FRONT ELECTRICAL AND SERVICE COMPARTMENT .....	10
BAGGAGE COMPARTMENTS .....	10
FUEL AND DIESEL EXHAUST FLUID (DEF) FILLER DOOR .....	11
BI-FOLD ENTRANCE DOOR .....	11
<i>Opening door</i> .....	11
<i>Closing door</i> .....	11
WHEELCHAIR LIFT ACCESS DOORS .....	12
REAR VIEW MIRRORS.....	12
HUBODOMETER.....	12

## 2-2 COACH EXTERIOR

### X3-45 COMMUTER EXTERIOR VIEWS

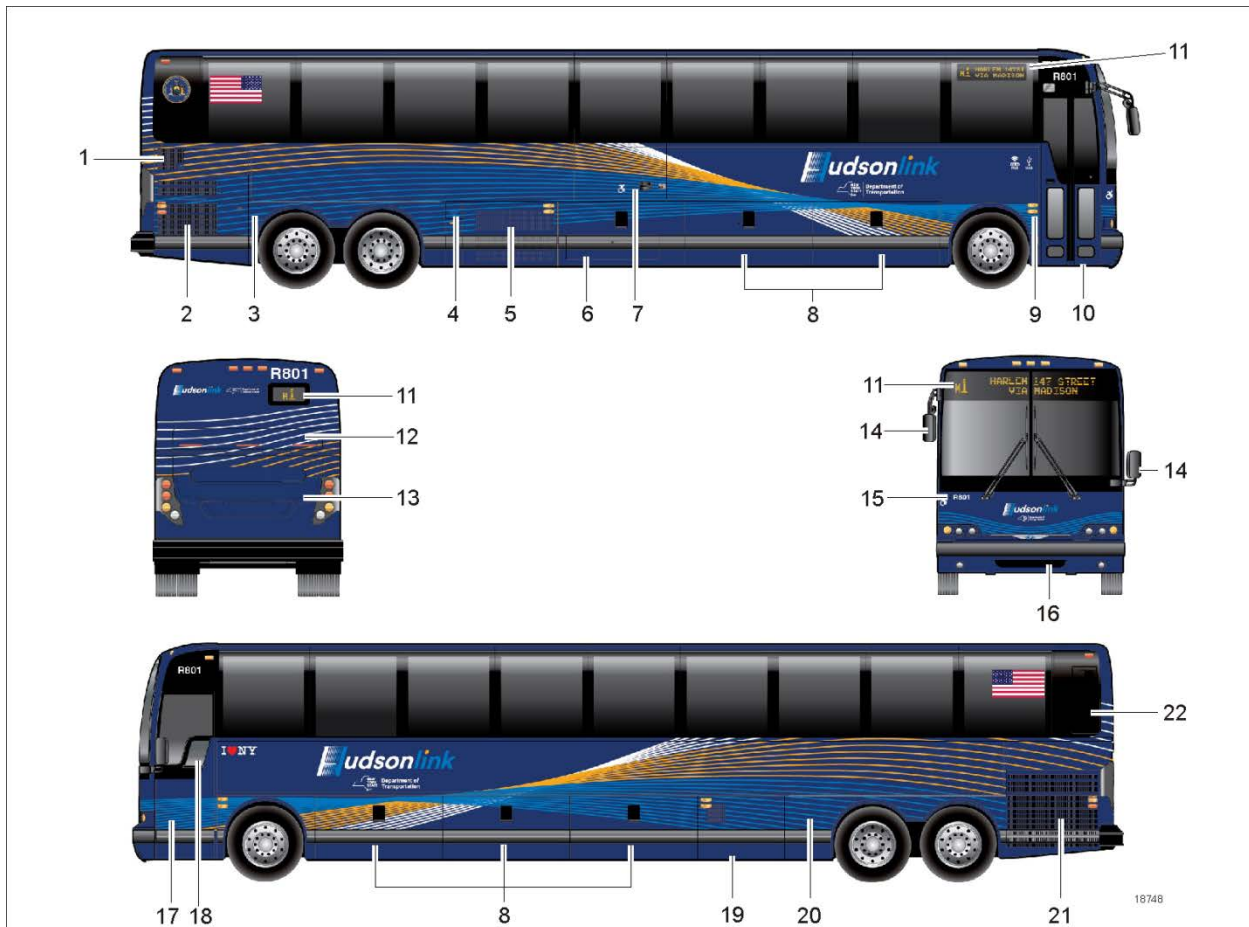

X3-45 EXTERIOR VIEW (TYPICAL)

- |   |   |
|---|---|
| 1. Engine air intake                            | 12. Exhaust aftertreatment system access door     |
| 2. Engine compartment curbside door             | 13. Engine compartment rear door                  |
| 3. Hinged rear fenders                          | 14. Rear-view mirrors                             |
| 4. Fuel filler neck & DEF filler neck door      | 15. Transmission retarder off indicator light     |
| 5. Condenser compartment                        | 16. Front towing air supply connector access door |
| 6. Lift mechanism access door                   | 17. Front electrical and service compartment      |
| 7. Wheelchair access door                       | 18. Driver's power window                         |
| 8. Baggage compartment                          | 19. Evaporator compartment                        |
| 9. Entrance door control switch                 | 20. Air dryer compartment                         |
| 10. Bi-fold entrance door                       | 21. Radiator door                                 |
| 11. Electronic destination sign or route number | 22. SCR converter access door                     |

## ENGINE COMPARTMENT OVERVIEW

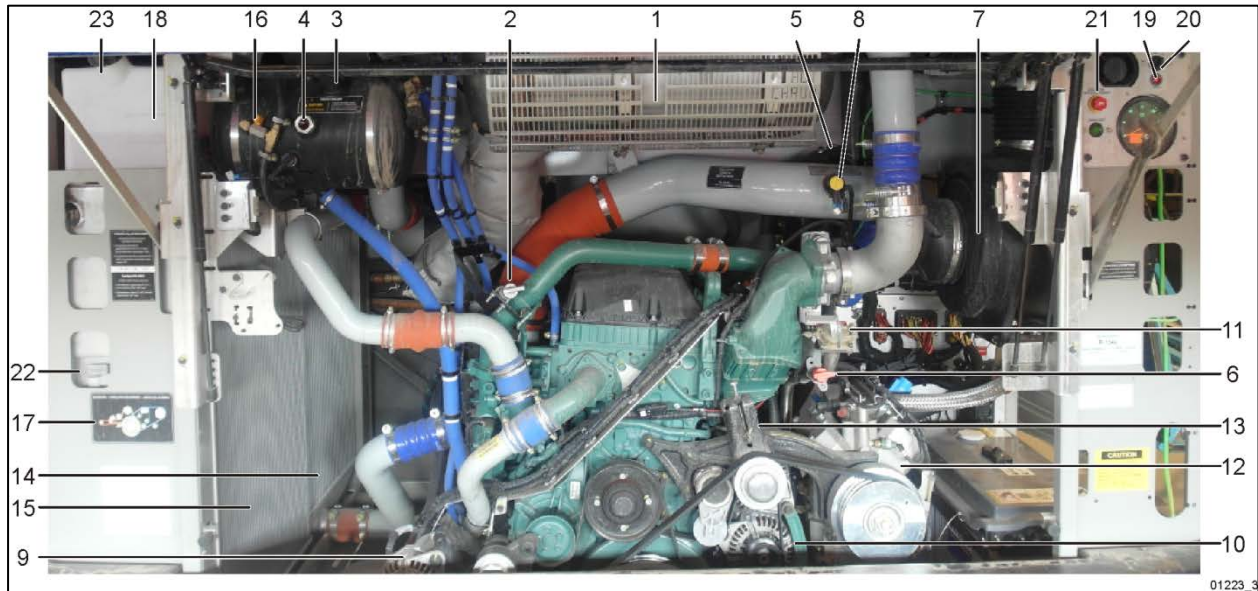

ENGINE COMPARTMENT FEATURING VOLVO D13 ENGINE

1. Diesel Oxidation Catalyst (DOC) & Diesel Particulate Filter (DPF) Assembly;
2. Allison Transmission fluid dipstick;
3. Coolant fluid surge tank filler cap;
4. Coolant fluid surge tank sight glass;
5. Power steering fluid reservoir;
6. Engine oil dipstick;
7. Air filter;
8. Air filter restriction sensor;
9. Alternator, Road side
10. Alternators, Curb side;
11. Engine oil filler tube;
12. Central A/C compressor;
13. Compressor belt tensioner;
14. Charge air cooler;
15. Radiator;
16. Coolant fluid pressure relief valve;
17. Belt routing tag;
18. Coolant recovery tank;
19. Air filter restriction indicator;
20. Engine compartment light switch;
21. Engine emergency stop button;
22. Radiator door opening lever;
23. Coolant recovery filler neck;

## 2-4 COACH EXTERIOR

### ENGINE COMPARTMENT CURBSIDE DOOR

The engine compartment curb-side door provides access to the following (if equipped):

- Engine compartment rear door release handle;
- Booster terminals;
- Main power compartment (rear junction box);
- Battery bank;
- Fuel filter/water separator;
- Air circuit fill valve;
- Battery charger 110 - 120 volt connector;
- Engine block heater 120-volts connector;

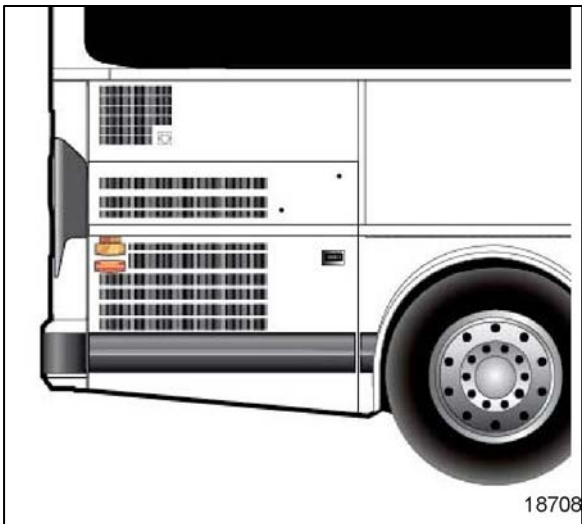

ENGINE COMPARTMENT CURB-SIDE DOOR

This door can be locked or unlocked using the square drive T-key.

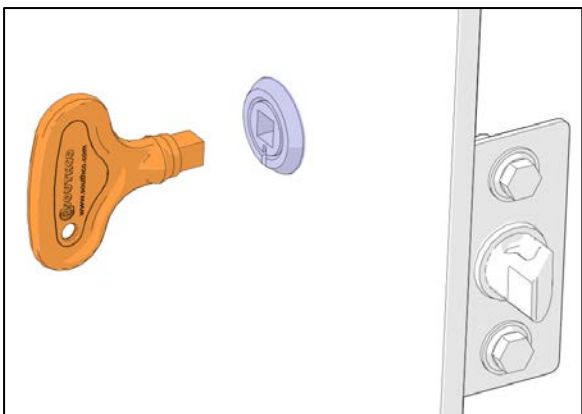

ENGINE COMPARTMENT R.H. SIDE 18607\_1

A telltale light illuminates when one or more compartments are unlocked.

### ENGINE COMPARTMENT REAR DOOR

To open the engine compartment rear door, open the engine compartment curb side door and pull the yellow handle located on the rear door, grab the side of the door in the middle, pull and lift the door.

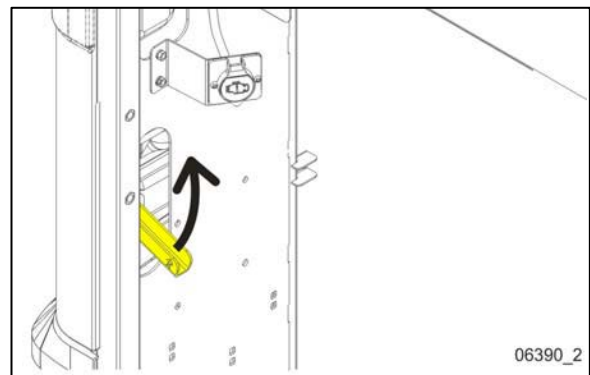

OPENING ENGINE COMPARTMENT REAR DOOR



### WARNING

Unless otherwise stated, do not run the engine when the engine compartment is open.

The door swings out to provide access to the following:

- Engine;
- Alternator(s);
- A/C Compressor;
- Belt tension control valve (refer to chapter, Care and Maintenance);
- Engine starting selector (refer to chapter, Starting and Stopping Procedures);
- Coolant line shutoff valves;
- Certification plates;
- Engine coolant surge tank and filler cap;
- Air filter restriction indicator;
- Engine oil dipstick and filler tube;
- Power steering fluid reserve tank;
- Allison transmission fluid dipstick;

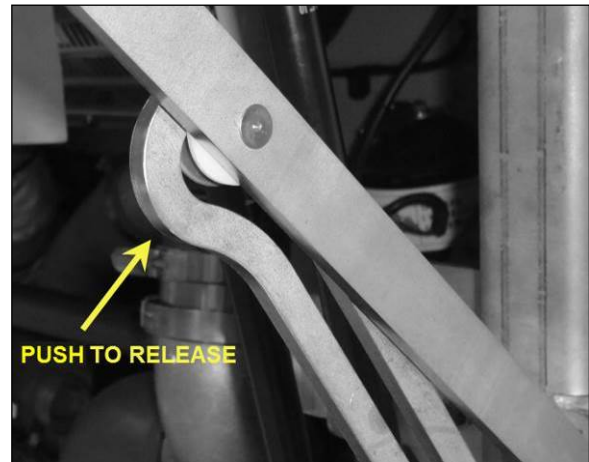

REAR DOOR SAFETY CATCH

### EXHAUST AFTERTREATMENT SYSTEM ACCESS DOOR

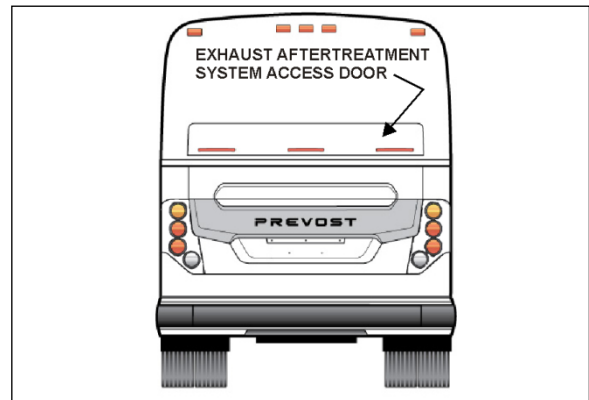

The engine door must be open before opening the exhaust aftertreatment system access door. To open the access door, lower the latch release lever, using a flat tip screwdriver.



To close the door, lower the door and push against the release lever spring to latch the door shut.

#### NOTE

*The engine compartment lights will turn on automatically when the engine door is opened. Check the engine compartment lamps switch on the right top corner if no light.*



A catch engages to maintain the door in the full open position. To close the door, slightly lift up the door and release the catch before firmly shutting down the door.



### ENGINE RADIATOR DOOR

The engine radiator door gives access to the radiator electrical fans and power distribution box.



**RADIATOR DOOR**

Open the engine compartment rear door to access the engine radiator door release handle

Radiator door release handle is located inside the left pillar (Arrow).



**RADIATOR DOOR HANDLE LOCATION**

Pull handle towards you to release radiator door.



**RADIATOR DOOR RELEASE HANDLE**

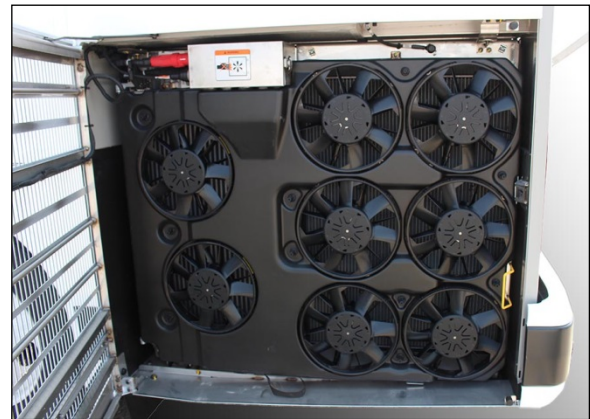

**RADIATOR DOOR OPENED**



### WARNING

#### WHEN THE ENGINE IS RUNNING...

Cooling fans may activate at any moment.

Keep hands away from cooling fans or keep the radiator door closed.



### WARNING

Cooling fans may be running when the engine is shut down in the following conditions:

- If a High Exhaust Temperature condition exists (e.g. following regeneration). The CAC fans will keep running for a maximum of 15 minutes.
- During the electric **Motor Test Sequence**, the cooling fans will start running briefly.

### SCR CONVERTER ACCESS DOOR

To gain access to the SCR converter, open the radiator door first. At the top of the radiator compartment, pull the catch connecting rod to unlock the catalytic converter access door and lift the door open.

Hold the door open by inserting the support rod free end into the receptacle located on the left side of the DPF.

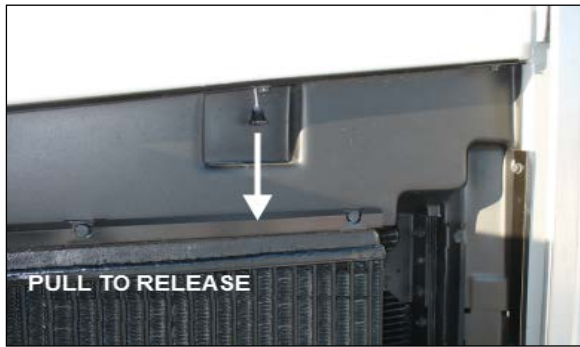

UNLOCKING SCR CONVERTER ACCESS DOOR



**WARNING**

After inserting the support rod into the receptacle, make sure the rod supports the door securely from falling down on to your head or body.

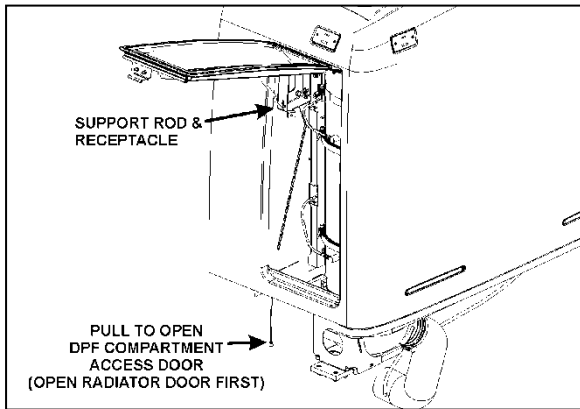

ACCESS TO THE SCR CONVERTER 04023



**WARNING**

External and internal temperatures remain hot long after engine has been shutdown. Allow the Exhaust Aftertreatment System to cool before handling. Wear protective clothing and glove while servicing.

**CONDENSER COMPARTMENT (A/C)**

Open the fuel filler neck access hatch and push the lever down to unlatch the condenser compartment door.

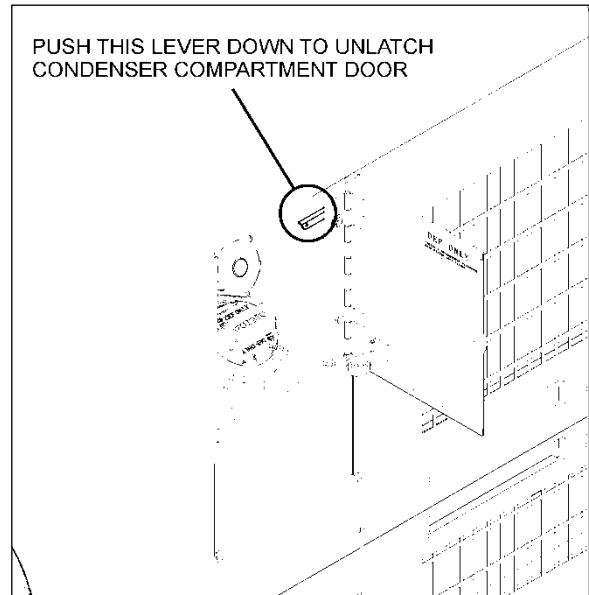

OPENING CONDENSER DOOR

The condenser compartment provides access to the following:

- Diesel Exhaust Fluid (DEF) Tank
- Condenser;
- Condenser fans and motors;
- Filter dryer and moisture indicator;
- Receiver tank;

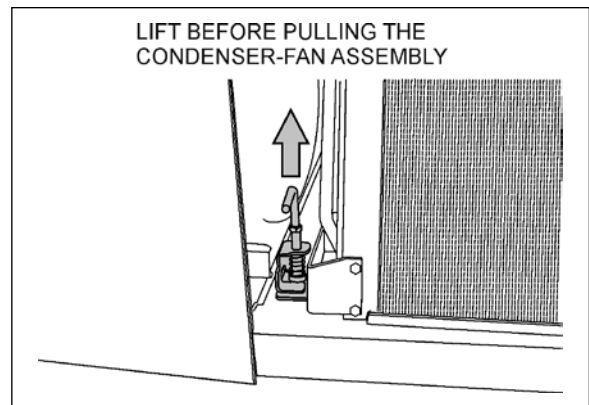

PULLING THE CONDENSER-FAN ASSEMBLY



**CAUTION**

Only the strap should be used to pull the condenser-fan assembly open. Damage to condenser could result if pulling by other means.

## 2-8 COACH EXTERIOR



CONDENSER COMPARTMENT STRAP

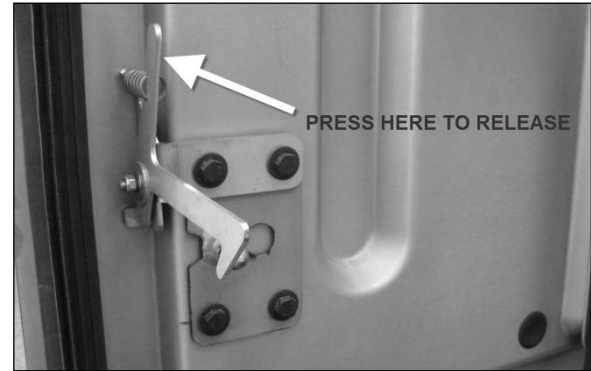

EVAPORATOR COMPARTMENT DOOR SECONDARY LOCK LEVER

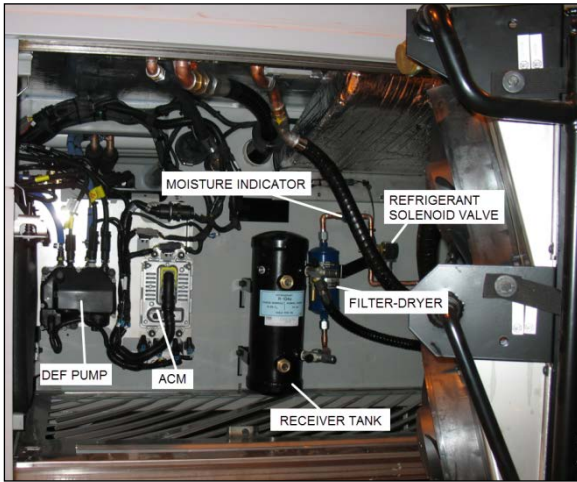

CONDENSER COMPARTMENT (A/C)

22299

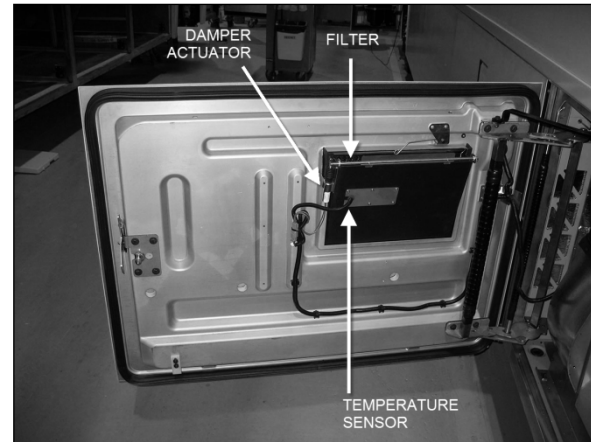

EVAPORATOR COMPARTMENT DOOR

The door features a recirculation damper actuator, a temperature sensor and a disposable filter.

### EVAPORATOR COMPARTMENT

The evaporator compartment door release latch is located in the baggage compartment located to its left. Pull the release latch then slide your hand in the opening to depress the evaporator compartment door secondary lock and swing open.

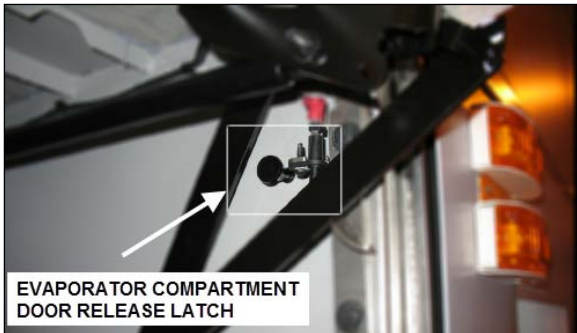

OPENING THE EVAPORATOR COMPARTMENT DOOR

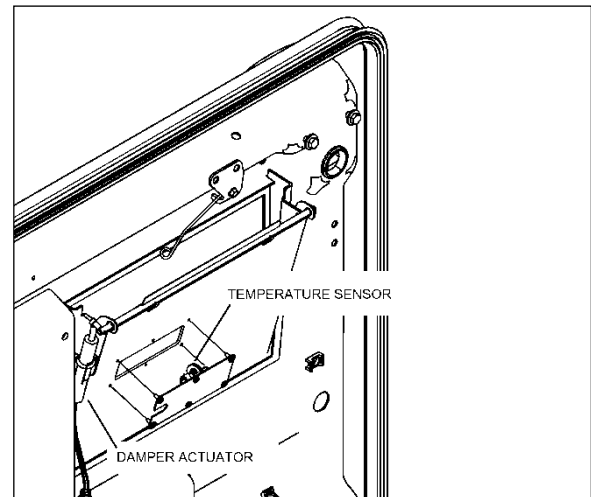

RECIRCULATION DAMPER AND TEMP. SENSOR 22302\_A



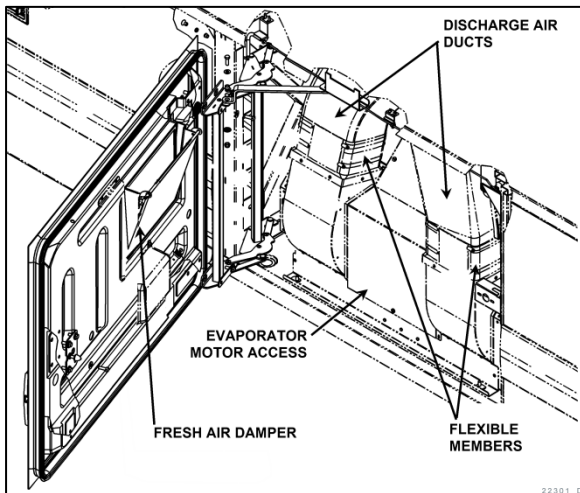

EVAPORATOR COMPARTMENT DOOR

**COOLANT HEATER COMPARTMENT**

The air dryer is found inside this compartment located aft of the evaporator compartment. To gain access, lift the rear fender.



COOLANT HEATER COMPARTMENT

**REAR FENDERS**

Rear fenders are hinged for maintenance on brakes and suspension. Each rear fender panel has two mechanical spring loaded holding devices fixing it to the vehicle's structure.

Step 1: Push rod "A" sideways to disengage the lock.

Step 2: Push rod "B" sideways to disengage the lock.

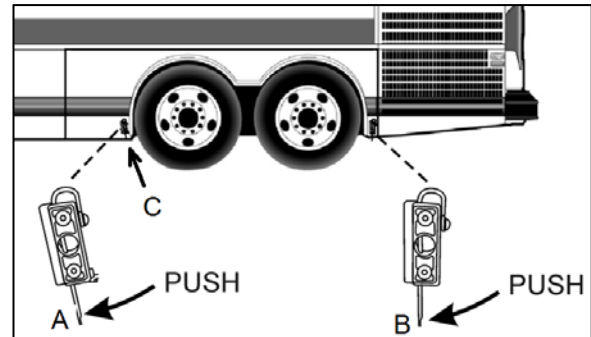

**UNLOCK REAR FENDERS**

Step 3: Pull the handle "C" on the left side to disengage the third lock.

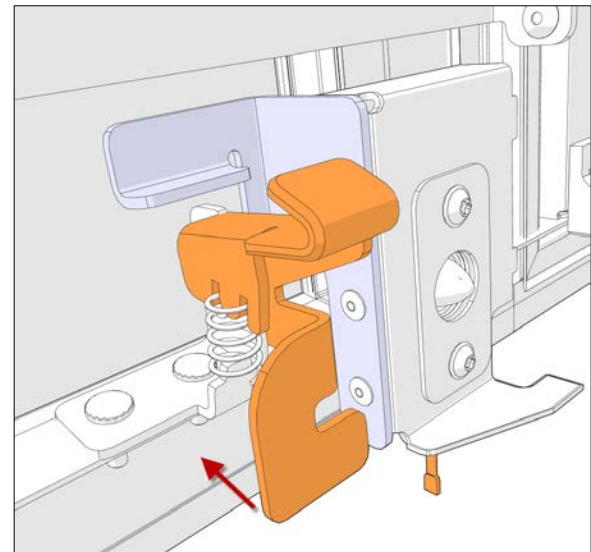

**UNLOCK REAR FENDERS**

## 2-10 COACH EXTERIOR

### FRONT ELECTRICAL AND SERVICE COMPARTMENT

Use the exterior compartment door key to open the front electrical and service compartment door from outside the coach. The front electrical and service compartment provides access to the following:

- Front terminal block;
- VECU;
- Vehicle Electrical Center Front (VECF), MCM and Multiplex Modules;
- C226 connector (MCM) type DB9 for laptop diagnostic tool;
- Relays and fuses;
- Tag axle control valve;
- ABS Electronic Control Unit (ECU);
- Emergency door unlatch valve;
- Master Interlock cancel switch;
- Windshield washer reservoir;
- Accessories system fill valve;
- Accessories air tank pressure relief cock;

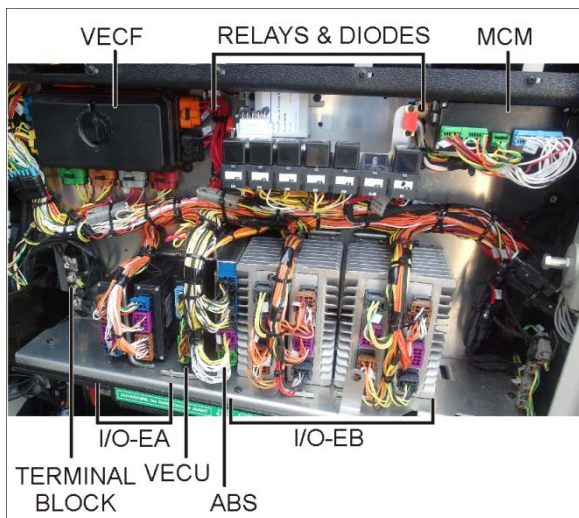

FRONT SERVICE COMPARTMENT ELECTRICAL PANEL

The light in the front electrical and service compartment turns *ON* automatically when the door is opened.

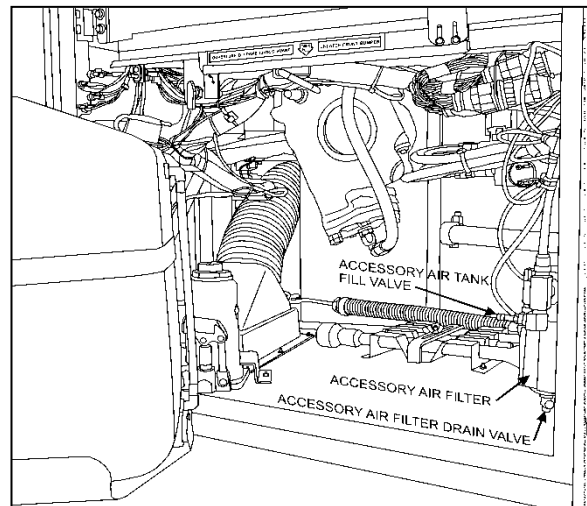

FRONT SERVICE COMPARTMENT

18611

### BAGGAGE COMPARTMENTS

The compartments can be locked or unlocked by using the provided key. The baggage compartments may also be locked using a seal on the operating handle.

Note that the two front compartments are only accessible from curb side while the third rear is accessible from both sides.

Lift up operating handle to release the latch, and then pull the door open by the handle rod. Pressurized cylinders assist the opening and closing of the baggage compartment doors and hold the doors open.

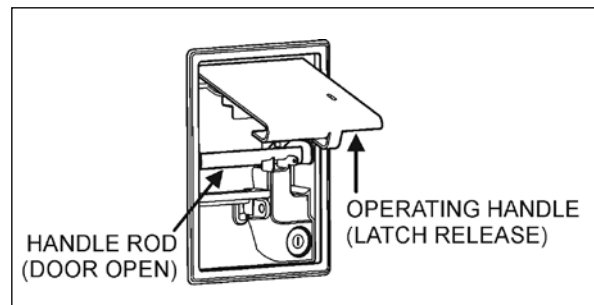

BAGGAGE DOOR LOCK AND LEVER

18693

To close, pull down the door by the handle rod. Complete the closing of the door by returning the operating handle to its initial position.



### CAUTION

Do not slam shut the baggage compartment doors. Damage to door weather-stripping or locking mechanism could result.

Lights in the baggage compartments turn *ON* automatically when the door is opened.



BAGGAGE DOOR CATCH 18612

**NOTE**

For added safety, open the door until the catch assist in holding the door in the open position.



**WARNING**

To avoid injury, keep hands clear of baggage compartment door edge and door frame when closing.

**FUEL AND DIESEL EXHAUST FLUID (DEF) FILLER DOOR**

The fuel and Diesel Exhaust Fluid (DEF) filler door is located on the R.H. side of the coach providing easy filling. A spring keeps the door either open or shut. The vehicle is equipped with Emco Wheaton POSI/LOCK 105 Automatic DRY-BREAK Fuelling System; the POSI/LOCK Filler Neck Assembly is installed on the fuel tank and requires the use of POSI/LOCK Refueling Nozzle for proper operation.

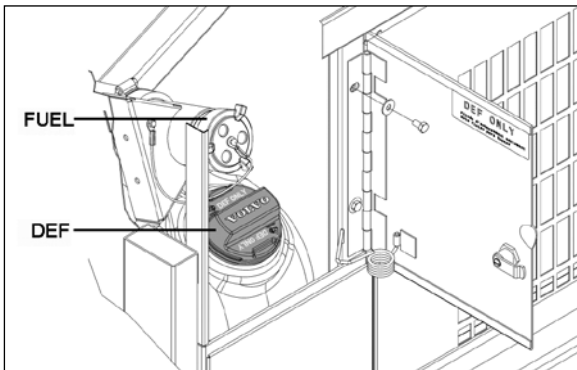

FUEL & DEF FILLER DOOR 03046

**NOTE**

Provided the vehicle is parked on level ground, an automatic nozzle will automatically shut off when fuel tank is approximately 95% full.



**CAUTION**

Diesel exhaust fluid DEF will begin to crystallize and freeze at 12°F (-11°C) and expand by 7% when frozen. To allow expansion without damaging the DEF tank, do not fill the tank with more than 15.9 gallons (60 liters).



**CAUTION**

Do not fill to more than 95% of the fuel tank capacity. Do not "top off" the tank, doing so may result in fuel spillage when the fuel expands.

**BI-FOLD ENTRANCE DOOR**

Lock or unlock the bi-fold entrance door from outside the vehicle by turning the key in the door lock (counterclockwise to lock, clockwise to unlock). The entrance door can be unlocked from the inside using the small lever located on the door.

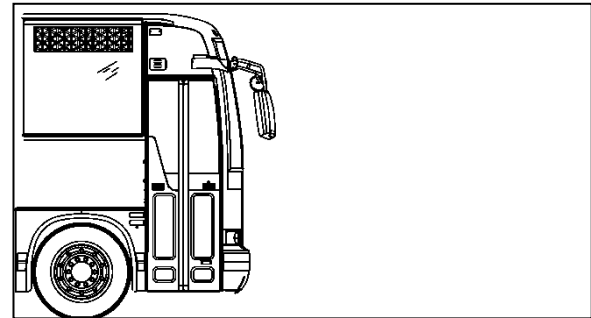

ENTRANCE DOOR 18001

**Opening door**

Opening the door requires only one push on exterior or interior door operating buttons. The door will open to full open position.

**Closing door**

To close the door, **push and hold** the exterior or interior door operating buttons. The door can be closed to any position by releasing the operating button when the desired position is attained. However, the door is not locked in any position

## 2-12 COACH EXTERIOR

other than fully closed. The door can therefore be closed further or opened by pushing or pulling on the door by hand.

### NOTE

The **interior and exterior door operating buttons** are disabled when the ignition is set to the OFF position for more than 15 minutes. To reactivate, press and hold the exterior button in the open position.

The **exterior door operating button** is disabled when the ignition is set to the ON position.

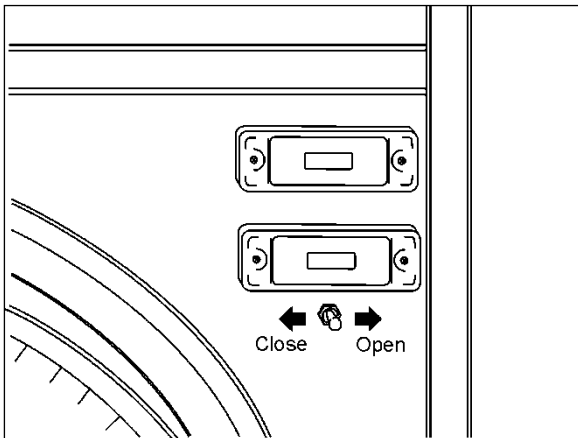

ENTRANCE DOOR EXTERIOR SWITCH 18599

### Door Operation Logic

Once the door is fully open or closed, the system holds pressure in the door cylinder, holding the door in that position.

The interior door opening button flashes when the vehicle speed is below 3 mph to indicate that the driver is allowed to open the door.

### Emergency Entrance Door Opening

Refer to "Safety Features and Equipment" section.

### WHEELCHAIR LIFT ACCESS DOORS

Refer to "Other Features" for more information on operating the wheelchair lift.

### REAR VIEW MIRRORS

The vehicle is equipped with flat-type and convex-type rear-view mirrors. Convex mirrors give a wide angle view. Objects viewed in convex-type rear-view mirrors appear smaller and are actually closer than they appear.

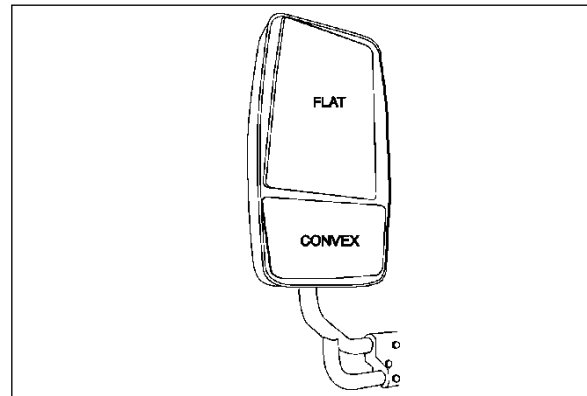

REAR VIEW MIRRORS (R.H. SHOWN)

L.H. and R.H. side mirrors are basically the same except that the R.H. side mirror support arm is also equipped with a round convex type mirror to provide better visibility in front of the vehicle R.H. side corner.



### CAUTION

Round convex type mirror is not adjustable.

The mirrors are adjusted using the controls located on the L.H. control panel. Refer to "Controls & Instruments" section. Manual adjustment is also possible.

### HUBODOMETER

An odometer is installed on the curbside drive axle wheel hub. The odometer calculates the total distance traveled by the coach since manufacture, including factory road testing.

### NOTE

It is normal for the hubodometer, the engine ECM and the vehicle odometer to disagree on the total mileage.

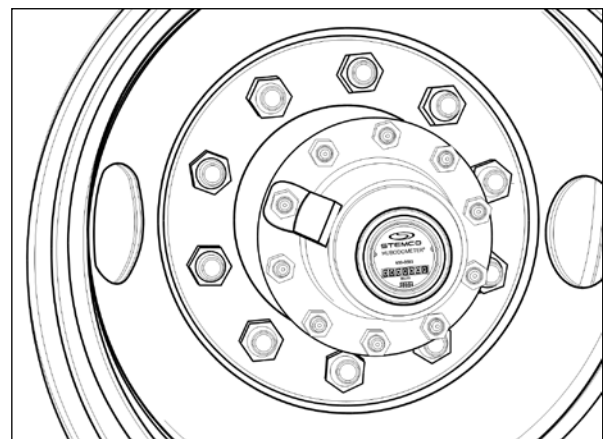

HUBODOMETER

13012