

## SECTION 2

<b>EXTERIOR VIEW</b> .....	<b>2</b>
<b>ENGINE COMPARTMENT COMPONENTS WITH DRIVER'S A/C</b> .....	<b>6</b>
<b>ENGINE COMPARTMENT CURBSIDE DOOR</b> .....	<b>8</b>
<b>ENGINE COMPARTMENT REAR DOOR</b> .....	<b>8</b>
<b>EXHAUST AFTERTREATMENT SYSTEM ACCESS DOOR</b> .....	<b>9</b>
<b>MAIN POWER COMPARTMENT</b> .....	<b>9</b>
<b>ENGINE RADIATOR DOOR</b> .....	<b>11</b>
<b>SCR CATALYTIC CONVERTER ACCESS HATCH</b> .....	<b>11</b>
<b>CONDENSER COMPARTMENT (A/C)</b> .....	<b>12</b>
<b>EVAPORATOR COMPARTMENT</b> .....	<b>12</b>
<b>FRONT ELECTRICAL AND SERVICE COMPARTMENT</b> .....	<b>13</b>
<b>BAGGAGE COMPARTMENTS</b> .....	<b>14</b>
<b>RECLINING BUMPER COMPARTMENT</b> .....	<b>15</b>
<b>FUEL AND DIESEL EXHAUST FLUID (DEF) FILLER DOOR</b> .....	<b>15</b>
<b>ENTRANCE DOOR</b> .....	<b>16</b>
OUTDOOR OPERATION .....	16
INSIDE OPERATION .....	16
<b>KEYLESS ENTRY SYSTEM</b> .....	<b>16</b>
<b>EXTERIOR REAR-VIEW MIRRORS</b> .....	<b>16</b>
<b>BACK-UP CAMERA</b> .....	<b>17</b>
<b>120-VOLT CONNECTOR</b> .....	<b>17</b>
<b>TRAILER HITCH</b> .....	<b>17</b>
TRAILER HITCH LOAD .....	18

## 2-2 Coach Exterior

### EXTERIOR VIEW

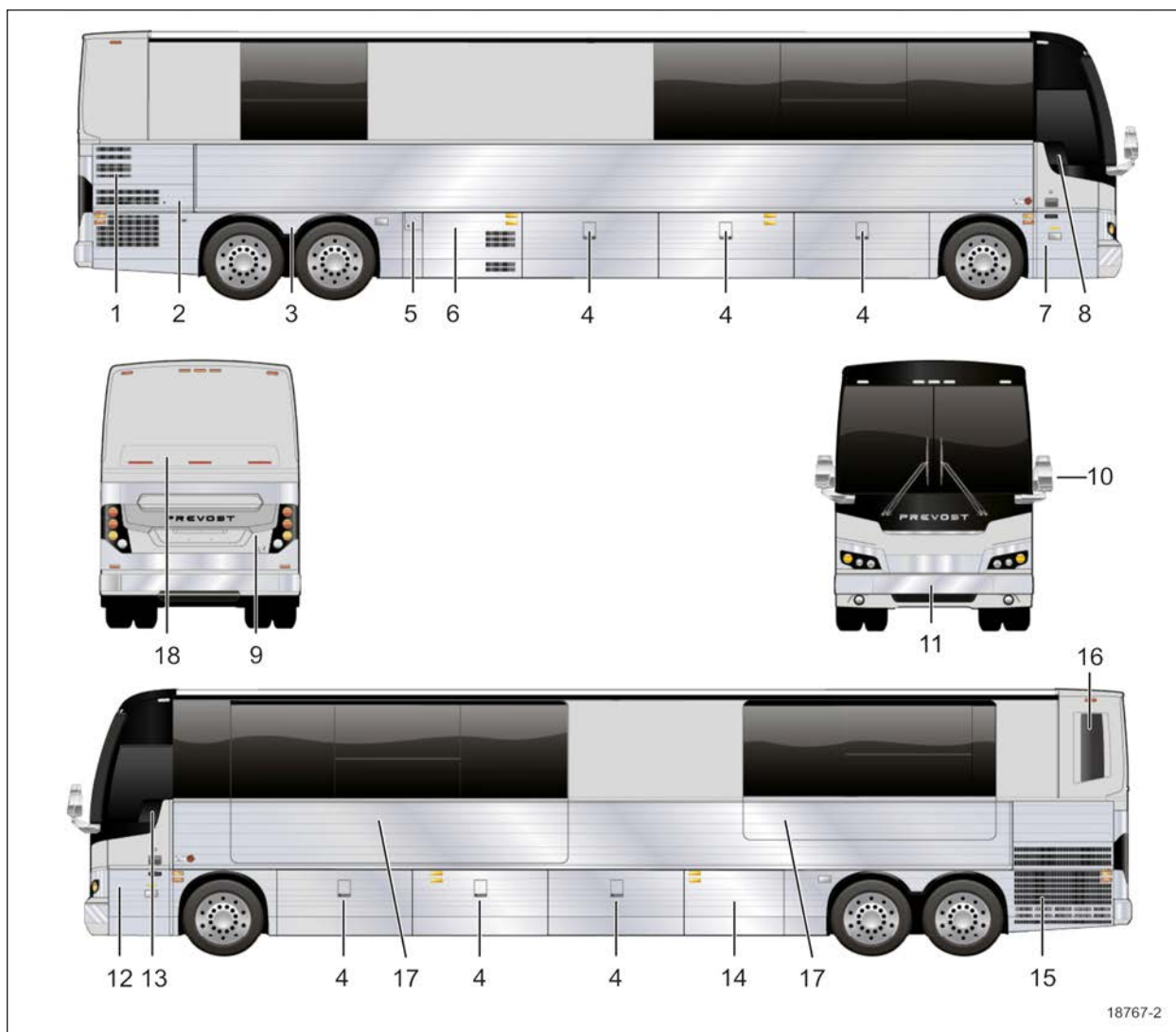

X3-45 VIP MOTORHOME EXTERIOR VIEW (TYPICAL)

1. Engine air filter intake grill
2. Engine compartment curbside door
3. Hinged rear fender
4. Baggage compartment
5. Fuel & DEF filler door
6. Condenser or baggage compartment
7. Entrance door
8. Entrance door power window
9. Engine compartment rear door
10. Rear-view mirrors
11. Reclining bumper
12. Front electrical and service compartment
13. Driver's power window
14. Evaporator or baggage compartment
15. Radiator door
16. Catalytic Converter access door
17. Slide-out (optional)
18. Exhaust aftertreatment system access door

## 2-4 Coach Exterior

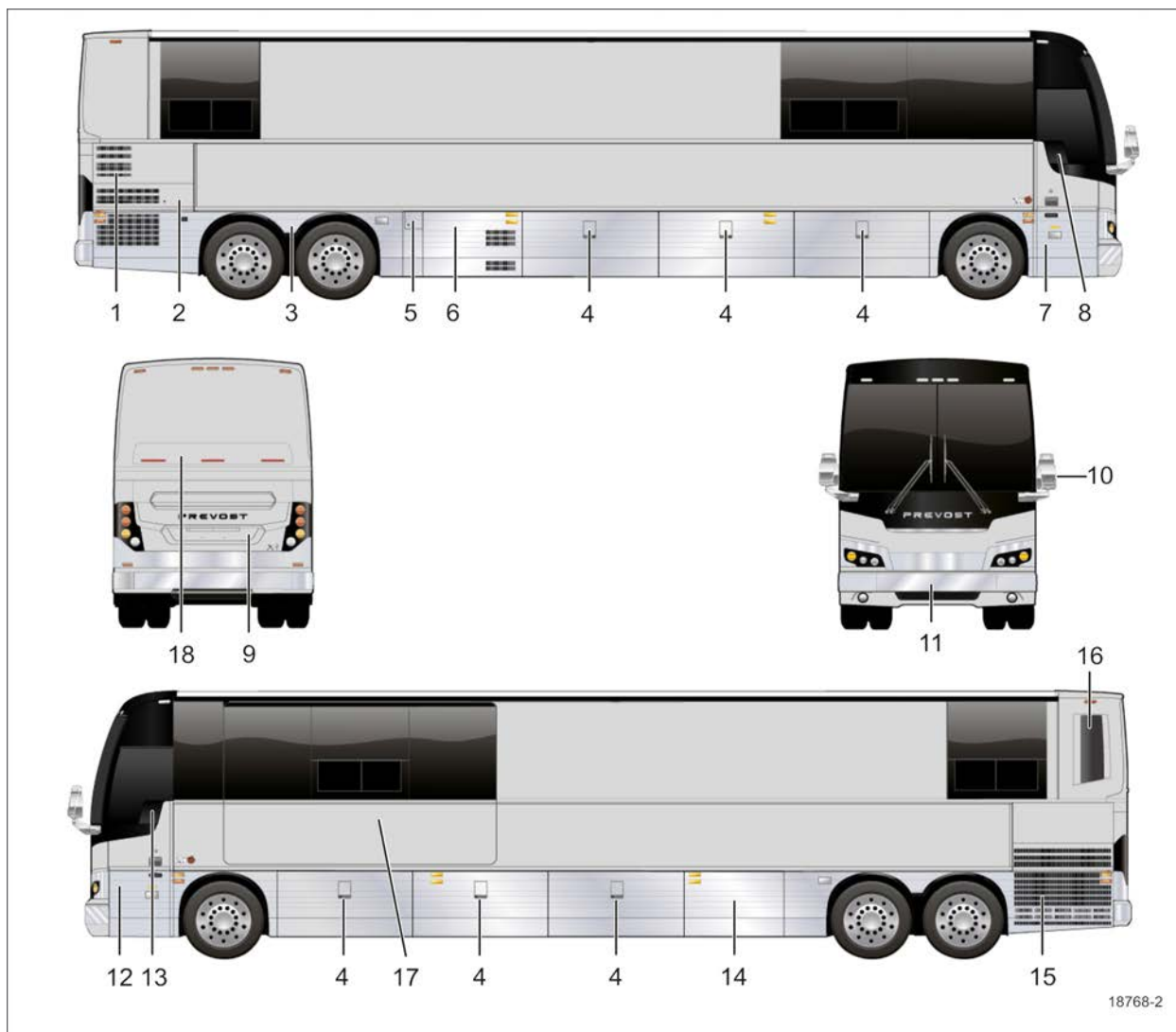

X3-45 VIP COMERCIAL USE VEHICLE TYPICAL EXTERIOR VIEW (FRONT SLIDE-OUT SHOWN)

1. Engine air filter intake grill
2. Engine compartment curbside door
3. Hinged rear fender
4. Baggage compartment
5. Fuel & DEF filler door
6. Condenser compartment
7. Entrance door
8. Entrance door power window
9. Engine compartment rear door
10. Rear-view mirrors
11. Reclining bumper
12. Front electrical and service compartment
13. Driver's power window
14. Evaporator or baggage compartment
15. Radiator door
16. Catalytic Converter access door
17. Front Slide-Out (Optional)
18. Exhaust aftertreatment system access door

## 2-6 Coach Exterior

### ENGINE COMPARTMENT COMPONENTS WITH DRIVER'S A/C

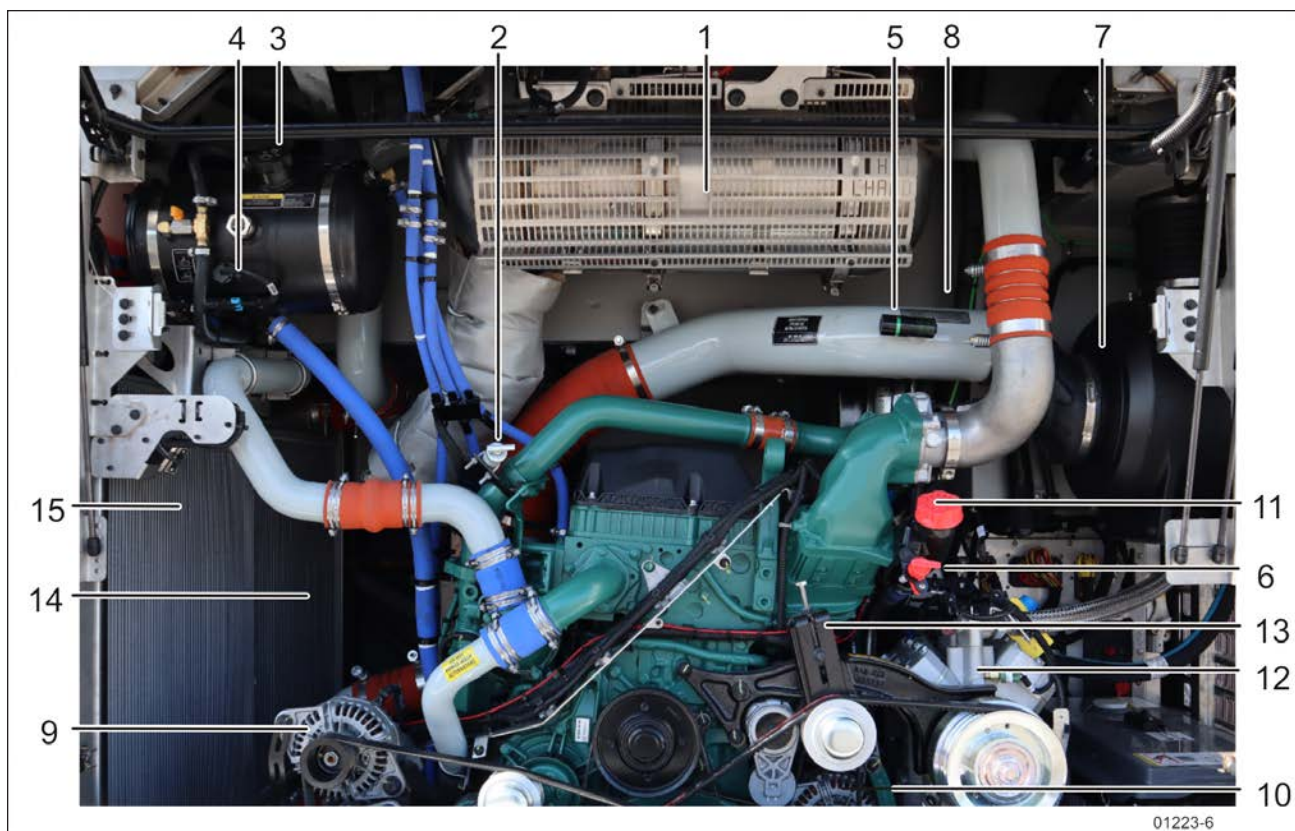

ENGINE COMPARTMENT FEATURING VOLVO D13 ENGINE

1. Diesel Oxidation Catalyst (DOC) & Diesel Particulate Filter (DPF) Assembly;
2. Transmission fluid dipstick (if equipped with Allison transmission);
3. Coolant fluid surge tank filler cap;
4. Coolant fluid surge tank sight glass;
5. Power steering fluid reservoir;
6. Engine oil dipstick;
7. Air filter;
8. Air filter restriction indicator;
9. Alternators, Road side
10. Alternators, Curb side;
11. Engine oil filler tube;
12. Driver's A/C compressor;
13. Radiator;
14. Charge air cooler;

## 2-8 Coach Exterior

### ENGINE COMPARTMENT CURBSIDE DOOR

The engine compartment curbside door provides access to the following (if equipped):

- Engine compartment rear door release lever;
- Booster terminals;
- Rear electrical panel;
- Rear junction panel;
- Battery compartment;
- Fuel filter/water separator;
- Primary air circuit fill valve and drain cock;
- 110 - 120 volt connector;
- A/C compressor;
- Battery equalizer;

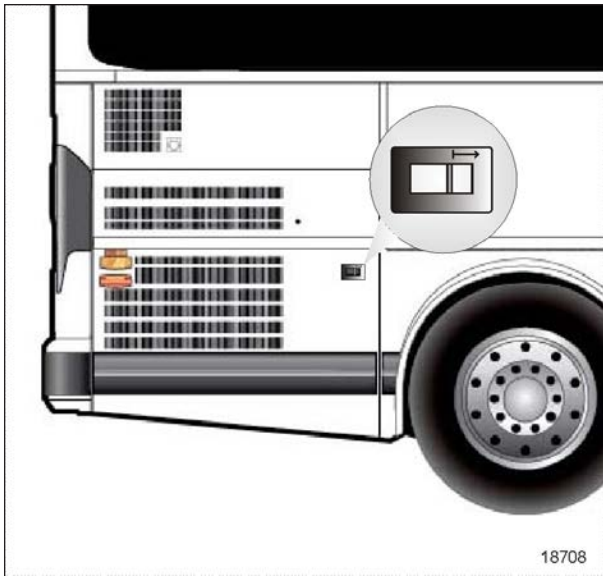

**ENGINE COMPARTMENT CURBSIDE DOOR**

This door can be locked or unlocked using the exterior compartment key or, if so equipped, by the central door locking system. To open, pull towards the front on the rod located in the recess to the right of the door.



**ENGINE COMPARTMENT R.H. SIDE**

A telltale light illuminates when one or more compartments are unlocked.

### ENGINE COMPARTMENT REAR DOOR

To open the engine compartment rear door, open the engine compartment curb side door and pull the yellow handle located on the rear door, grab the side of the door in the middle, pull and lift the door.



**OPENING ENGINE COMPARTMENT REAR DOOR**



### **WARNING**

Unless otherwise stated, do not run the engine when the engine compartment is open.



The door swings out to provide access to the following:

- Engine;
- Alternators;
- Compressor(s);
- A/C belt tensioner (refer to "[CENTRAL A/C COMPRESSOR BELTS](#)" on page 11 in Care and Maintenance);
- Engine starting selector (refer to "[STARTING FROM THE ENGINE COMPARTMENT](#)" on page 3 in Starting and Stopping Procedures);
- Coolant line shutoff valves;
- Engine certification plates;
- Engine coolant surge tank and filler cap;
- Air filter restriction indicator;
- Engine oil dipstick;
- Power steering fluid reserve tank;
- Allison automatic transmission fluid dipstick;

#### NOTE

*The engine compartment lights will turn on automatically when the engine door is opened*

A catch engages to maintain the door in the full open position. To close the door, slightly lift up the door and release the catch before firmly shutting down the door.

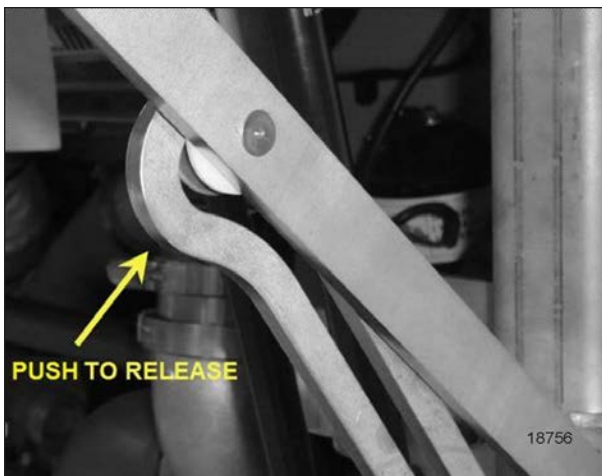

REAR DOOR SAFETY CATCH



#### WARNING

Unless otherwise specified, do not run the engine when the engine compartment rear door is open. Close the engine compartment rear door before starting the engine.

#### EXHAUST AFTERTREATMENT SYSTEM ACCESS DOOR



The engine door must be open before opening the exhaust aftertreatment system access door. To open the access door, pull down the latch release knob.



AFTERTREATMENT ACCESS DOOR LATCH

To close the door, lower the door and push against the release lever spring to latch the door shut.

#### MAIN POWER COMPARTMENT

The main power compartment (a.k.a. rear junction box) and battery installation are accessible from the engine compartment curbside door.

## 2-10 Coach Exterior

The batteries are housed and secured on the engine R.H. side deck. The battery posts and connections are protected by a watertight cover. The cover is fitted with a built-in vent. The cover can be unlocked and then removed with the use of the same type of hardware that allows opening and closing of the rear fender.

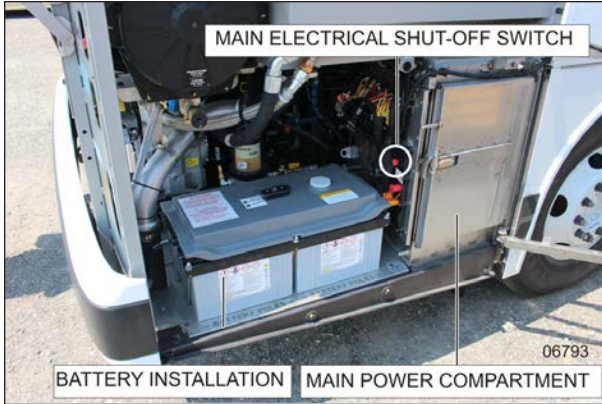

### ENGINE R.H. SIDE COMPARTMENT (TYPICAL)

The main power compartment panel provides access to the following:

- Rear 12VD, 24VD junction blocks
- Main circuit breakers
- AE49, AE50, AE51, AE52 I/O-EB Multiplex modules
- Vehicle Electrical Center Rear (VECR)
- Master relay R1
- 12V ignition relay R3
- Starter relay
- Relays and fuses
- Battery equalizer
- 12VD & 24 VD current sensors

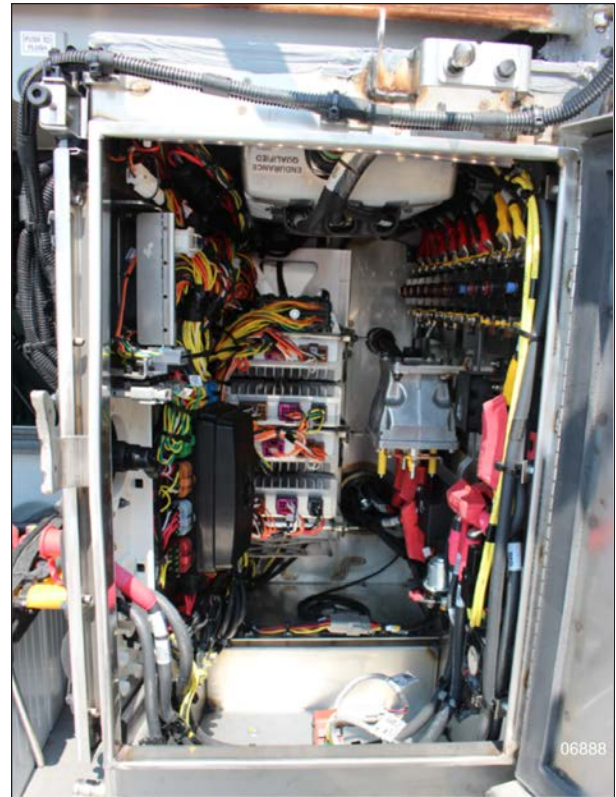

MAIN POWER COMPARTMENT (TYPICAL)

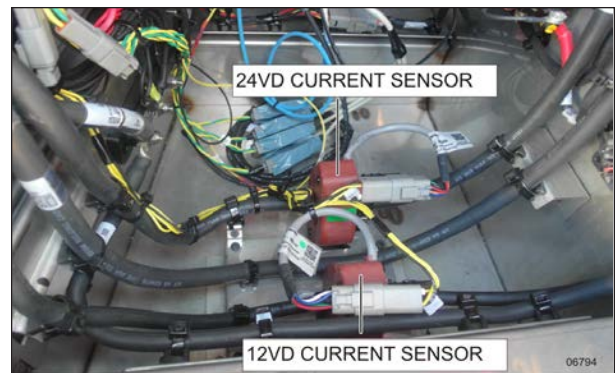

12VD / 24VD CURRENT SENSORS IN MPC (TYPICAL)

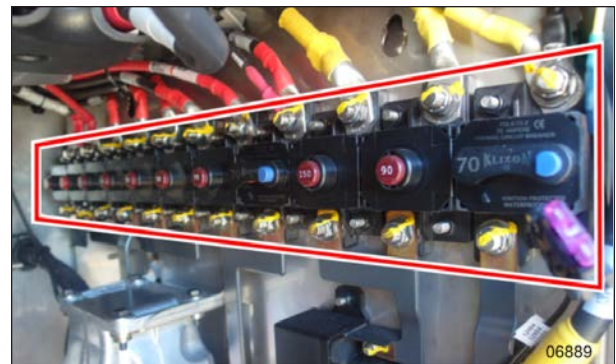

MAIN CIRCUIT BREAKERS IN MPC (TYPICAL)

## ENGINE RADIATOR DOOR

The engine radiator door gives access to the radiator electrical fans and power distribution box.



**RADIATOR DOOR**

Open the engine compartment rear door to access the engine radiator door release handle.

Radiator door release handle is located inside the left pillar (Arrow).



**RADIATOR DOOR HANDLE LOCATION**

Pull handle towards you to release the radiator door.



**RADIATOR DOOR RELEASE HANDLE**



**RADIATOR DOOR OPENED**



### WARNING

WHEN THE ENGINE IS RUNNING...

Cooling fans may activate at any moment.

Keep hands away from cooling fans or keep the radiator door closed



### WARNING

**Cooling fans may be running when the engine is shut down in the following conditions:**

- If a High Exhaust Temperature condition exists (e.g. following regeneration). The CAC fans will keep running for a maximum of 15 minutes.
- During the electric Motor Test Sequence, the cooling fans will start running briefly.

## SCR CATALYTIC CONVERTER ACCESS HATCH

The hatch is located on the road side (left side) above the radiator door.

To gain access to the SCR catalytic converter:

1. Open the radiator door first;
2. Pull the catch connecting rod to unlock the access hatch;
3. Lift the hatch open;
4. Hold the door open by inserting the support rod free end into the receptacle.

## 2-12 Coach Exterior

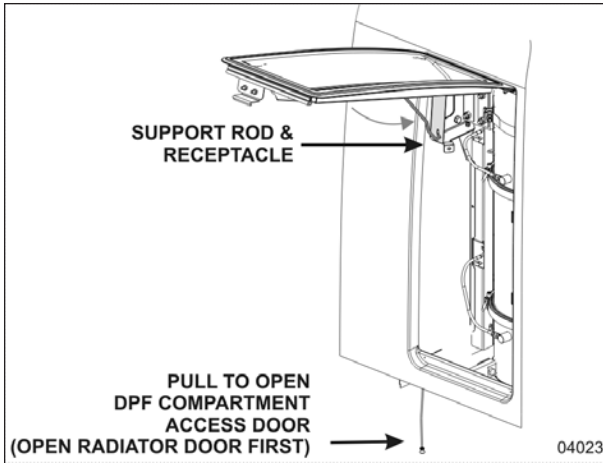

### ACCESS TO THE SCR



### WARNING

After inserting the support rod into the receptacle, make sure the rod supports the door securely from falling down on to your head or body.



### WARNING

External and internal temperatures remain hot long after the engine has been shut down. Allow the Exhaust Aftertreatment System to cool before handling. Wear protective clothing and gloves while servicing.

## CONDENSER COMPARTMENT (A/C)

The following information is for vehicle equipped with a central A/C system.

Pull the release latch located inside the adjacent baggage compartment to open the condenser door.

The condenser compartment provides access to the following:

- Diesel Exhaust Fluid (DEF) Tank
- Condenser;
- Condenser fans and motors;
- Filter dryer and moisture indicator;
- Receiver tank;

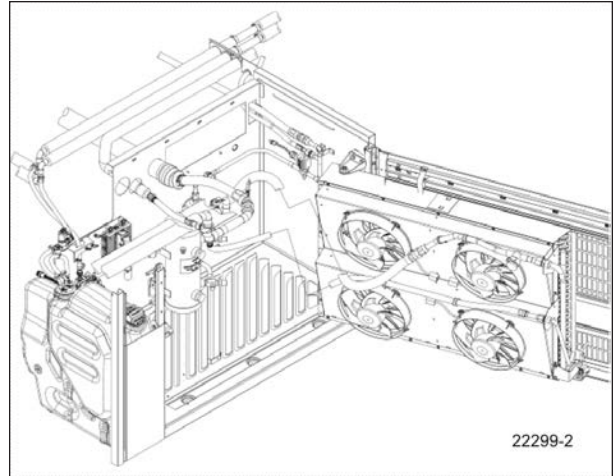

### CONDENSER COMPARTMENT (A/C)

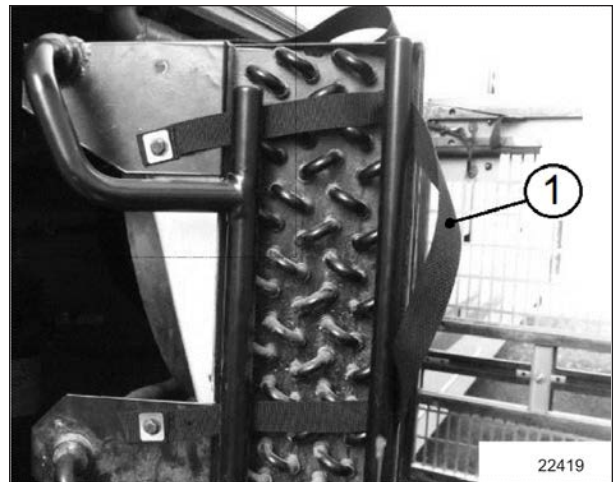

### CONDENSER COMPARTMENT STRAP



### CAUTION

Only the strap should be used to pull the condenser-fan assembly open. Damage to condenser could result if pulling by other means

## EVAPORATOR COMPARTMENT

The following information is for vehicle equipped with a central A/C system.

The HVAC (Heating, Ventilating and Air-Conditioning) evaporator and heater coils are located in this compartment along with the blowers.

The evaporator compartment door release latch is located on the right wall of the baggage compartment, left of the door. Pull the release latch then slide your hand in the opening to depress the secondary lock and swing open.

Temperature sensor is located behind the front bumper under the driver side head lights.



**EVAPORATOR COMPARTMENT**



**SECONDARY LOCK LEVER**

## **FRONT ELECTRICAL AND SERVICE COMPARTMENT**

To open the front electrical and service compartment door, pull the rod inside the vehicle, next to the driver's power window or use the key to open from outside the coach.

The electrical section of the front compartment provides access to the following:

- Vehicle Electrical Center Front (VECF)
- Relays and diodes
- Master Control Module (MCM)
- Front terminal block
- IOE-B Multiplex Modules
- VECU
- ABS Electronic Control Unit (ECU)
- IOE-A Multiplex Modules
- Keyless module

The lower section of the front service compartment provides access to the following:

- Windshield washer reservoir & headlights washer reservoir (optional)
- Accessories air tank fill valve
- Accessories air tank drain valve

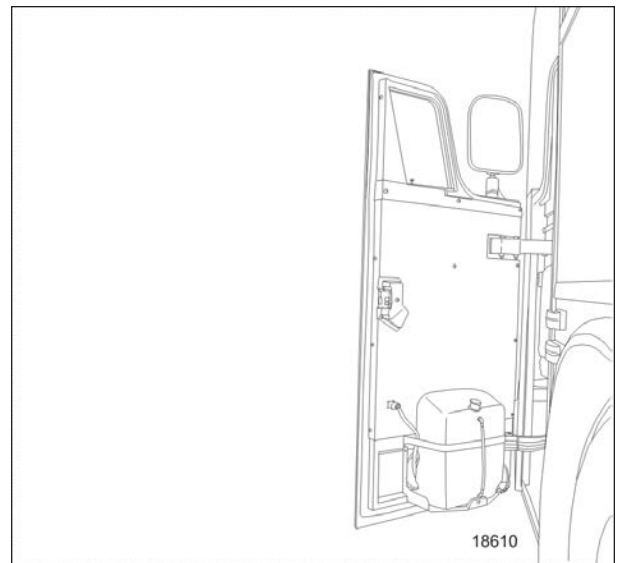

**FRONT SERVICE COMPARTMENT DOOR**

This compartment door can be locked/unlocked using the exterior compartment key.

## 2-14 Coach Exterior

The light in the front electrical and service compartment turns on automatically when the door is opened.

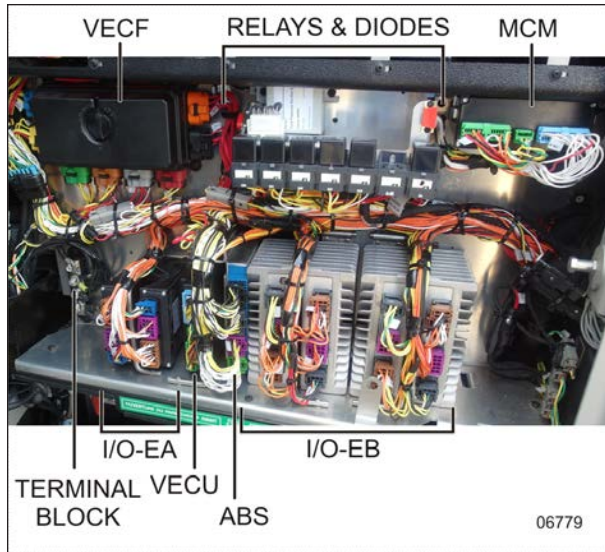

**FRONT ELECTRICAL COMPARTMENT**

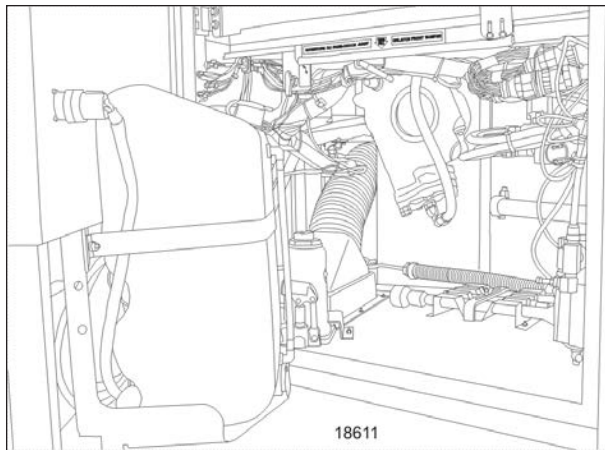

**FRONT SERVICE COMPARTMENT**

## BAGGAGE COMPARTMENTS

The baggage compartments of the X3-45 provide 406 ft<sup>3</sup> (11.5 m<sup>3</sup>) of storage capacity. The compartments can be locked or unlocked by using the exterior compartment key. Pull up operating handle to release the latch, and then pull the door open. Pressurized cylinders assist the opening and closing of the baggage compartment doors and hold the doors open.

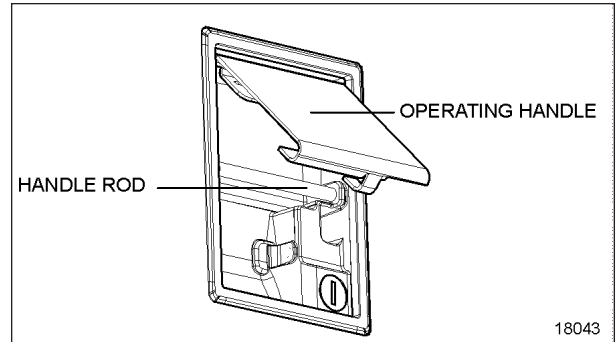

**BAGGAGE DOOR LOCK AND LEVER**

To close, pull the door down by the handle rod. Complete the closing of the door by returning the operating handle to its initial position.



### CAUTION

Do not slam shut the baggage compartment doors. Damage to the door weather-stripping or locking mechanism could result.

Lights in the baggage compartments turn on automatically when the door is opened.



**BAGGAGE DOOR LOCK AND LEVER**

### NOTE

*The baggage compartment doors can be locked/unlocked from the driver's position by the optional central locking system. The switch is on the L.H. control panel. Refer to "Controls & Instruments" chapter.*

### NOTE

*For added safety, open the door until the catch assist in holding the door in the open position. Lift lever to release the door*

**WARNING**

To avoid injury, keep hands clear of baggage compartment door edge and door frame when closing.

**NOTE**

To prevent theft and vandalism, always lock the baggage compartment doors before leaving the vehicle unattended.

**RECLINING BUMPER COMPARTMENT**

The front bumper can be tilted downward to give access to the bumper compartment. Pull the release handle located inside front service compartment to unlock. Tilt down the entire bumper assembly to access the compartment. Push the bumper back up firmly in place to lock in position.

Check that bumper is securely closed shut before driving.

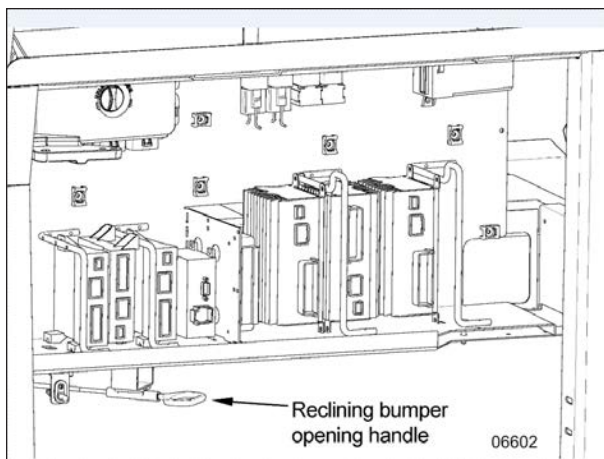
**RECLINING BUMPER OPENING HANDLE****WARNING**

The compartment behind the bumper is not designed for miscellaneous storage. Never store loose objects in this compartment since they can interfere with the steering linkage mechanism.

**WARNING**

Although a powerful spring assists in reclining the bumper, it remains heavy and rests low when open. Caution should be used when reclining.

**FUEL AND DIESEL EXHAUST FLUID (DEF) FILLER DOOR**

The fuel and Diesel Exhaust Fluid (DEF) filler door is located on the L.H. side of the coach providing easy filling. The vehicle is also equipped with a R.H. door with fuel filler only.

A spring keeps the door either open or shut. A key is provided for unlocking the door if the option was chosen.

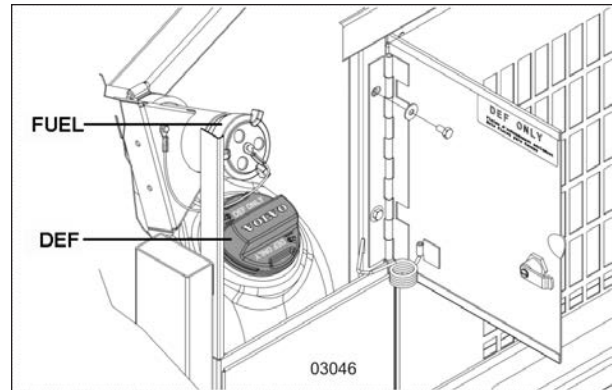
**FUEL & DEF FILLER DOOR****NOTE**

Provided the vehicle is parked on level ground, an automatic nozzle will automatically shut off when the fuel tank is approximately 95% full.

**NOTE**

The fuel & DEF filler door must be in the unlocked position before closing

**WARNING****DEF – Do not overfill**

If an automatic nozzle is used for filling diesel exhaust fluid (DEF), do not add further DEF after the nozzle has automatically shut off flow a first time.

If such nozzle is not available, use the DEF level gage on the instrument panel to control the quantity during filling.

Diesel exhaust fluid DEF will begin to crystallize and freeze at 12°F (-11°C) and expand by 7% when frozen. To allow expansion without damaging the DEF tank, do not fill the tank with more than 16 gallons (60 liters).

## 2-16 Coach Exterior



### WARNING

Do not fill to more than 95% of the fuel tank capacity. Do not "top off" the tank, doing so may result in fuel spillage when the fuel expands.

## ENTRANCE DOOR

### OUTDOOR OPERATION

Lock or unlock the entrance door from outside the vehicle by either turning the key in the door lock (counterclockwise to lock, clockwise to unlock), by using the outside key pad, or by using the remote control (electronic key). Open the door by pulling on the lever. Close by pushing the door shut.

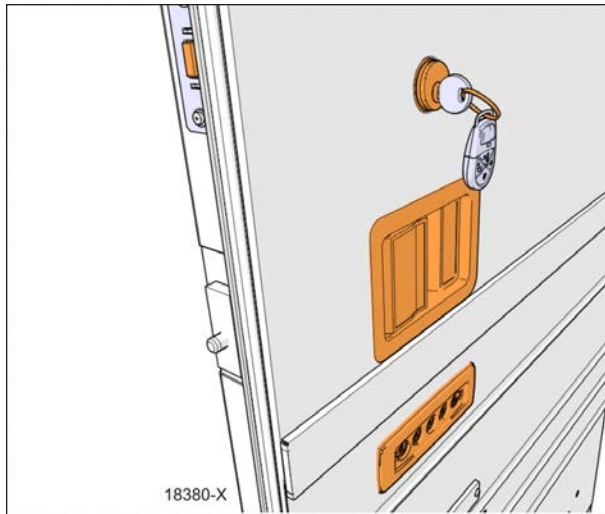

OUTSIDE LOCKING DEVICES

### NOTE

*The stepwell lights and entrance overhead light turn on as the door opens.*

### INSIDE OPERATION

There are two ways of unlocking the entrance door from the inside. The first consists in actuating the rocker switch on the R.H. dashboard panel. This operation will also operate the baggage compartment locking devices.

It is also possible to unlock the entrance door by sliding its lock lever to the left.

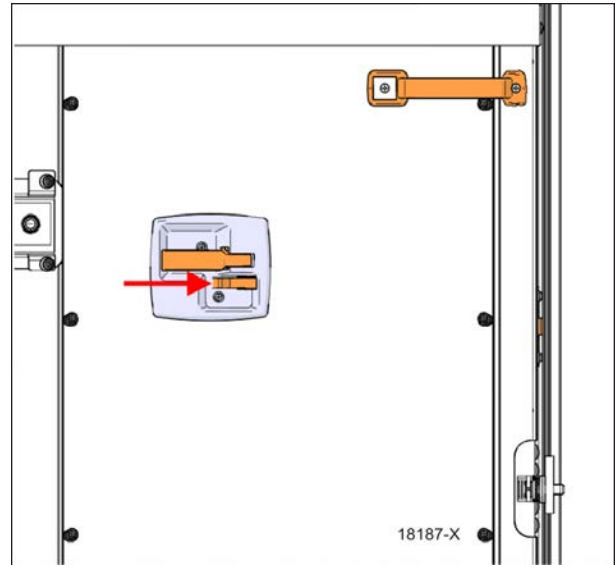

INSIDE LOCKING DEVICES

### NOTE

*If the alarm system is armed, unlocking the entrance door from the inside by sliding its lock knob will not disarm the alarm system. The alarm will sound.*

### NOTE

*For complete information regarding the Keyless Entry System & Anti-theft Alarm System, refer to the document included in your vehicle's "publication box".*

## KEYLESS ENTRY SYSTEM

This system, located below the entrance door handle, is used to lock or unlock the entrance door, the baggage compartment and the service compartment. A default 4-digit access code is permanently preprogrammed in the module by the manufacturer. A 6-digit authority code will also be supplied to the owner and will be used to store up to 40 new personal access codes (4-digit).

### NOTE

*Refer to "Other Features" chapter for complete keyless system operating instructions.*

## EXTERIOR REAR-VIEW MIRRORS

The vehicle is equipped with flat-type and convex-type rear-view mirrors. Convex mirrors give a wide-angle view. Objects viewed in convex-type rear-view



mirrors appear smaller and are actually closer than they appear.

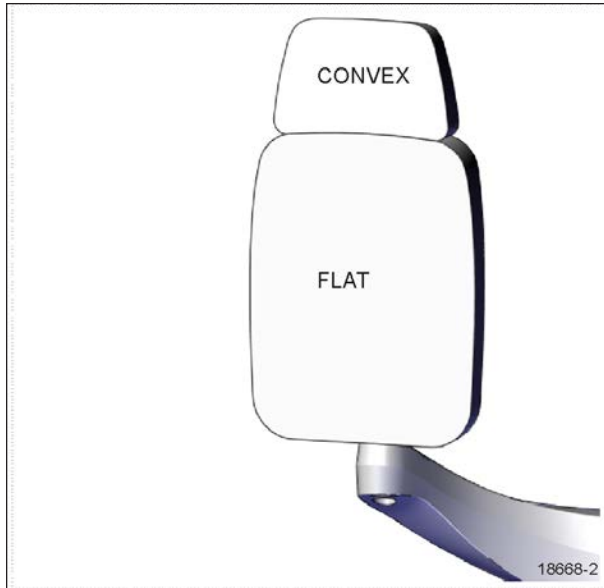

EXTERIOR REAR-VIEW MIRROR

To provide good visibility in cold weather, the mirrors can be equipped with heating elements. The elements are activated by a rocker switch located on the dashboard. Refer to "Controls & Instruments" chapter. Thermostats are used to prevent continuous operation of the heating elements.



**CAUTION**

Do not attach stick-on type convex mirror accessories to the heated mirror glass. This could impede uniform heat distribution on the mirror surface and could break the mirror glass.

As an option, the mirrors may be equipped with LED turning signal lights to give an additional signal light when turning or changing lane for extra safety or for other drivers to see your signal when driving too close, in rain, fog or when in blind spot.

The mirrors are adjusted using the controls located on the L.H. control panel. Refer to "Controls & Instruments" chapter. Manual adjustment is also possible.

Adjust the side-view mirrors until the side of the vehicle is visible. Adjust the flat-type mirror until the road behind is in full view.

**BACK-UP CAMERA**

An optional back-up camera is available which provides the driver with visual assistance when

backing-up. The back-up camera is mounted in a housing with a retractable cover. For additional information, refer to Controls and Instruments and Care and maintenance chapters.

**NOTE**

A switch located in the rear electric compartment is used to retract the back-up camera cover for cleaning or maintenance.



**CAUTION**

Never try force to rotate by hand the retractable cover. Damage may occur.

**120-VOLT CONNECTOR**

This connector is used with a 120 volts supply and is connected to the optional engine block heater. Refer to Starting and Stopping Procedures chapter.

**TRAILER HITCH**

Your vehicle may be equipped with a factory-installed trailer hitch which has been designed to meet the following rating:

**Maximum gross trailer weight:**

**20,000 lbs. (9072 kg)**

**Maximum tongue weight at 6 1/2 inches (165 mm) or less from coupling receiver:**

**1,500 lbs. (680 kg)**

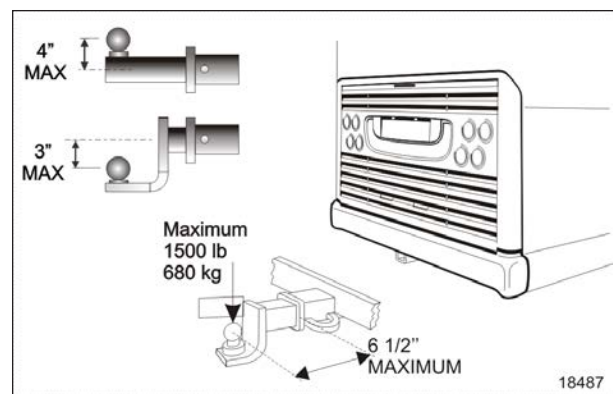

TRAILER HITCH



**DANGER**

The draw bar and the ball used for towing the trailer should be rated for 20,000 lbs. capacity or more.

## 2-18 Coach Exterior



### WARNING

Pulling a trailer weighing more than the recommended *maximum gross weight* may cause engine and transmission overheating, and a possible hitch failure.

### NOTE

*Pulling a trailer over long distances is considered as a "severe operating condition" for the vehicle. The engine will require more frequent servicing.*

### TRAILER HITCH LOAD

The minimum requirement for a trailer weighing up to 20,000 lbs. when coupled to a 20,000 lbs. Prevost Trailer Hitch is as per the following:

1. Trailer must comply with **Federal Motor Carrier Safety Regulations 393.52** regarding trailer braking capability.
2. The trailer coupling attachments must meet the following minimum static test load requirements. Use the indicated Gross Trailer Weight Rating (GTWR) of your trailer and multiply by the indicated value below.
  - Longitudinal tension and compression: (1.5 x GTWR)
  - Transverse thrust: (0.5 x GTWR)
  - Vertical tension and compression: (0.5 x GTWR)

*Loads indicated must be applied without incurring loss of attachments or distortion or failure which could affect the safe towing of trailer.*

3. The ball and trailer coupling must meet the following minimum test load requirements without incurring failure. Use the indicated Gross Weight Rating (GTWR) of your trailer and multiply by the indicated value below.
  - Longitudinal tension and compression: (GTWR x 3)
  - Transverse thrust: (GTWR x 1)
  - Vertical tension and compression: (GTWR x 1.3)

*In this case, failure is identified as the point at which the coupling or ball will accept no additional test load without separation of the ball from the coupling ball*

*socket, or the occurrence of a metal fracture of either coupling ball or coupling assembly, which results in separation of the ball from the coupling ball socket.*

4. Two lengths of safety chain shall be used. The strength rating (minimum breaking force) of each individual chain and its connecting means shall be equal to, or exceed the trailer's Gross Weight Rating (GTWR).
5. Towing vehicle must be equipped with engine or transmission retarder. The engine or the transmission retarder on the vehicle must be functional at all time (to be inspected frequently).

*This hitch must be for recreational use only.*