

## SECTION 2

<b>EXTERIOR VIEW</b> .....	<b>2</b>
<b>ENGINE COMPARTMENT COMPONENTS</b> .....	<b>4</b>
<b>ENGINE COMPARTMENT CURBSIDE DOOR</b> .....	<b>6</b>
<b>ENGINE COMPARTMENT DOOR</b> .....	<b>6</b>
<b>EXHAUST AFTERTREATMENT SYSTEM ACCESS DOOR</b> .....	<b>7</b>
<b>MAIN POWER COMPARTMENT</b> .....	<b>7</b>
<b>RADIATOR DOOR</b> .....	<b>8</b>
<b>SCR CATALYTIC CONVERTER ACCESS HATCH</b> .....	<b>8</b>
<b>A/C CONDENSER COMPARTMENT</b> .....	<b>8</b>
<b>EVAPORATOR COMPARTMENT</b> .....	<b>9</b>
<b>FRONT ELECTRICAL AND SERVICE COMPARTMENT</b> .....	<b>10</b>
<b>BAGGAGE COMPARTMENTS</b> .....	<b>11</b>
<b>RECLINING BUMPER COMPARTMENT</b> .....	<b>11</b>
<b>FUEL AND DIESEL EXHAUST FLUID (DEF) FILLER NECK ACCESS</b> .....	<b>11</b>
<b>ENTRANCE DOOR</b> .....	<b>12</b>
OUTDOOR OPERATION .....	12
INSIDE OPERATION .....	13
<b>KEYLESS ENTRY SYSTEM</b> .....	<b>13</b>
<b>EXTERIOR REAR-VIEW MIRRORS</b> .....	<b>13</b>
<b>BACK-UP CAMERA</b> .....	<b>14</b>
<b>120-VOLT CONNECTOR</b> .....	<b>14</b>
<b>TRAILER HITCH</b> .....	<b>14</b>
TRAILER HITCH LOAD .....	15

## 2-2 Coach Exterior

### EXTERIOR VIEW

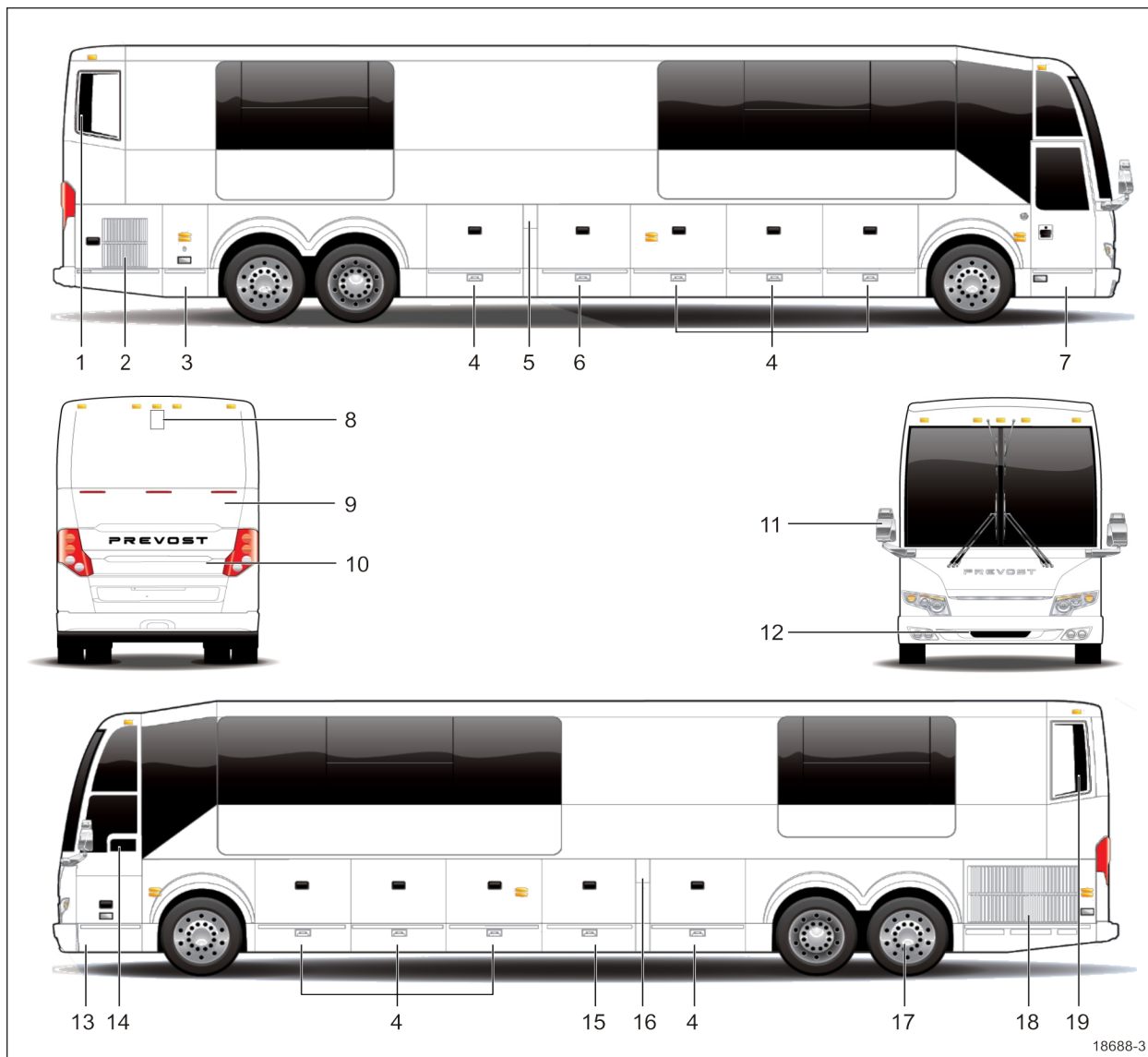

H3-45 VIP EXTERIOR VIEW

1. Engine air intake
2. Engine R.H. side access door
3. Main power compartment (battery compartment)
4. Baggage compartment
5. Fuel filler neck access door
6. A/C condenser or baggage compartment
7. Entrance door
8. Retractable backup camera (optional)
9. Diesel Particulate Filter (DPF) access door
10. Engine compartment rear door
11. Rear-view mirror
12. Reclining bumper compartment
13. Front electrical and service compartment
14. Driver's power window
15. Heating, ventilating and air conditioning compartment (HVAC) or baggage compartment
16. Fuel filler neck and diesel exhaust fluid (DEF) filler neck access door
17. Auxiliary axle (TAG)
18. Engine radiator door
19. SCR catalytic converter access door

## 2-4 Coach Exterior

### ENGINE COMPARTMENT COMPONENTS

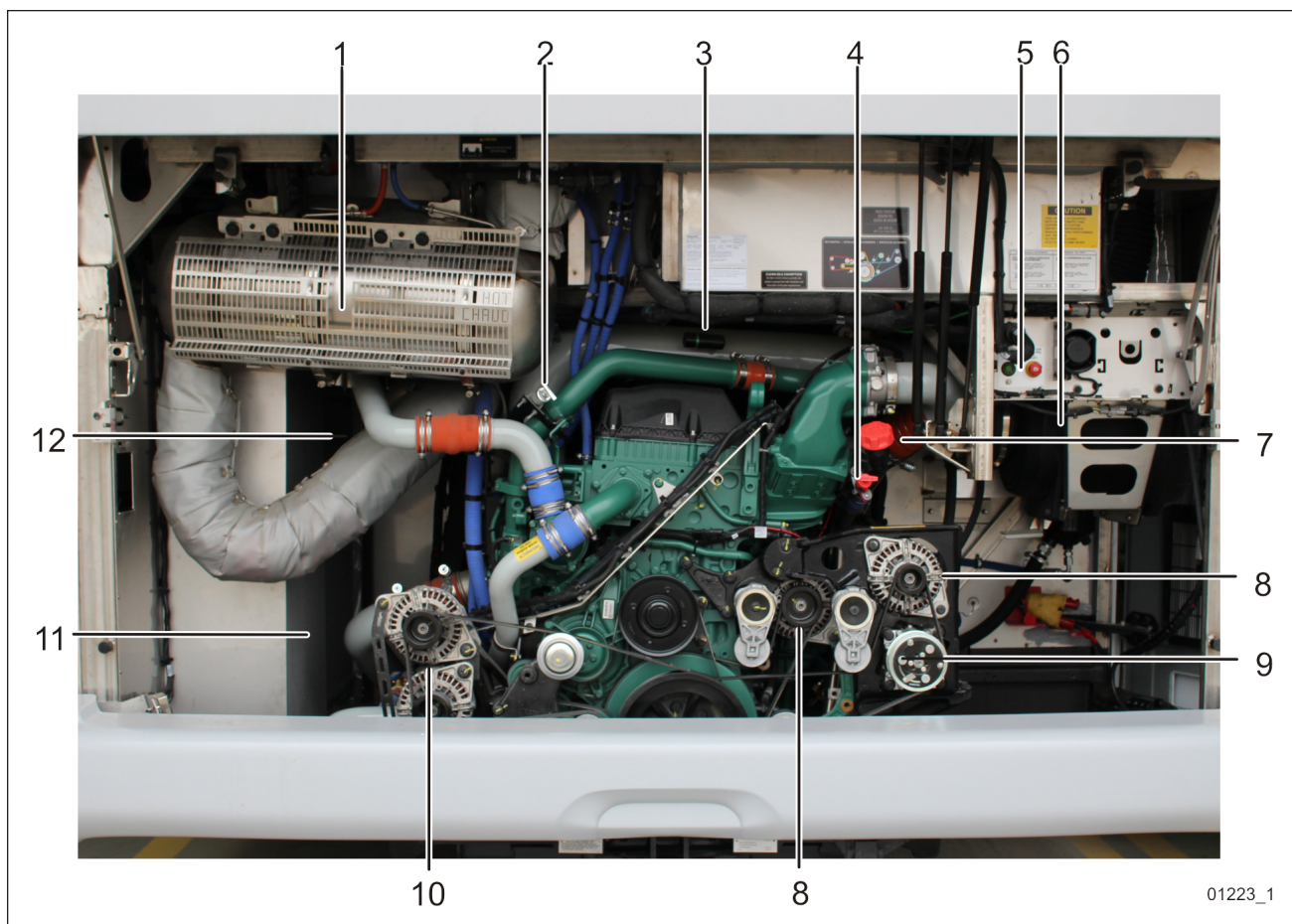

ENGINE COMPARTMENT FEATURING VOLVO D13 ENGINE

1. Diesel Oxidation Catalyst (DOC) & Diesel Particulate Filter (DPF) Assembly;
2. Transmission fluid dipstick (if equipped with Allison transmission);
3. Air filter restriction indicator;
4. Engine oil dipstick;
5. Rear start / stop panel;
6. Air filter;
7. Engine oil filler tube and cap;
8. Alternators, Curb side;
9. Small A/C compressor;
10. Alternators, Road side;
11. Radiator;
12. Charge air cooler (CAC).

## 2-6 Coach Exterior

### ENGINE COMPARTMENT CURBSIDE DOOR

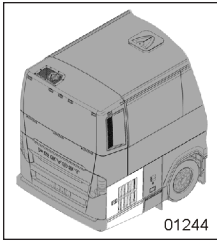

Lock this door using the exterior compartment key. To open, pull up the door handle to release the latch and then pull the door open.

The curbside door also has a safety catch to prevent it from closing inadvertently. Release the catch before attempting to close.

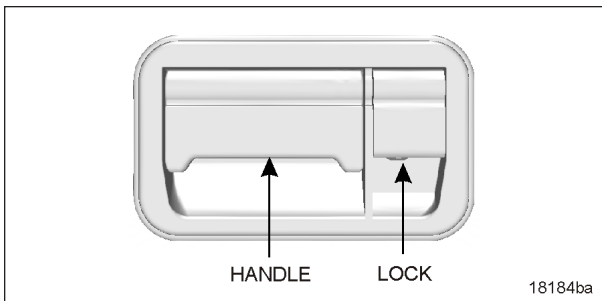

#### DOOR HANDLE

The engine compartment curbside door provides access to the following (if equipped):

- Engine compartment rear door release lever
- Davco Fuel Pro 382 filtration system
- Primary & secondary air system fill valve
- Power steering fluid tank
- Booster block terminals
- Wet air tank drain cock
- Engine air filter
- Battery charger 110-120 volts connector
- Engine block heater 110-120 volts connector



#### WARNING

Unless otherwise stated, do not run the engine when the engine compartment curbside door is open.

### ENGINE COMPARTMENT DOOR

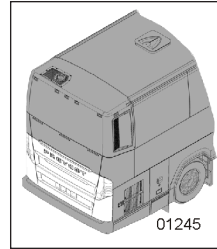

To open the engine door, first open the curbside door. Lift the latch release lever. Unlatch the door and pull it out and up.

The door should stay open by itself but it is recommended to always use the safety catch as shown. The lighting in the engine compartment turns on automatically when the door is open. When open or not closed properly, a pictogram appears on the instrument cluster DID. To close the door, lift it slightly and release the safety catch.

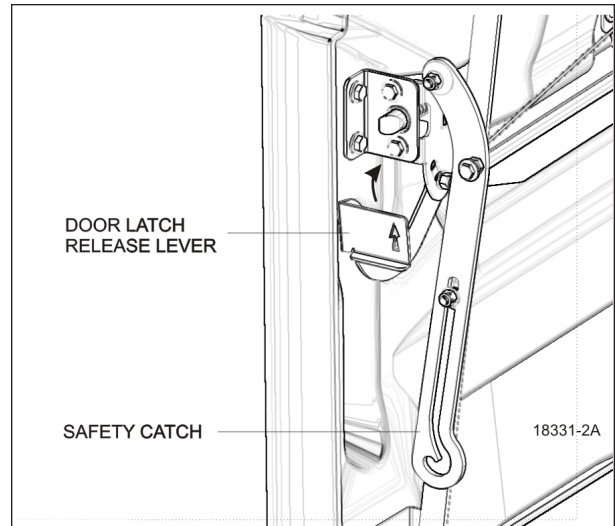

#### OPENING THE ENGINE COMPARTMENT DOOR

This door provides access to the following equipment:

- Engine
- Alternators
- Belts and belt tensioners
- Compressor(s)
- Rear starter switch (see "[STARTING FROM THE ENGINE COMPARTMENT](#)" on page 3 in Section 6 Starting and Stopping Procedures)
- Engine certification plate
- Air filter restriction indicator
- Engine oil dipstick and filler cap

- Transmission oil dipstick
- Cooling fluid surge tank level tube



### WARNING

Unless otherwise stated, do not run the engine when the engine compartment door is open.

## EXHAUST AFTERTREATMENT SYSTEM ACCESS DOOR

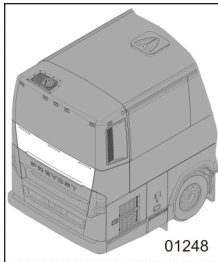

The engine door must be opened before opening the DPF access door. To open the DPF access door, press the latch release lever. Using both hands, push the door up until it locks in place.

To close the door, press the latch release lever again and lower the door, holding it with both hands.

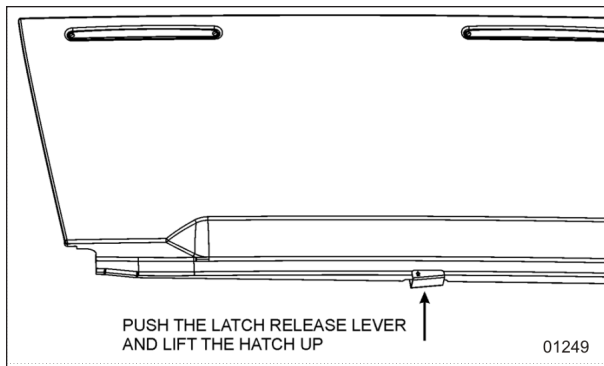

EXHAUST AFTERTREATMENT SYSTEM ACCESS DOOR

## MAIN POWER COMPARTMENT

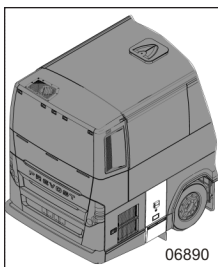

To unlock the main power compartment door, use the exterior compartment door key. The door will pop open.

The compartment light turns on automatically when the door is open and the ignition switch is in the ON position. A telltale light indicating that a compartment door is open will illuminate on the dashboard.

This compartment is closed off from the engine compartment and is used to house the batteries and electrical components. The following items are located in the main power compartment:

- (4x) 12-volt batteries
- Main circuit breakers (12 & 24 volts)
- Battery charger (optional)
- Vanner battery equalizer
- Rear multiplex modules
- Transmission Electronic Control Module for Allison transmission or Volvo I-Shift
- Rear fuse box (VECR)
- Relays
- Electronic ground stud

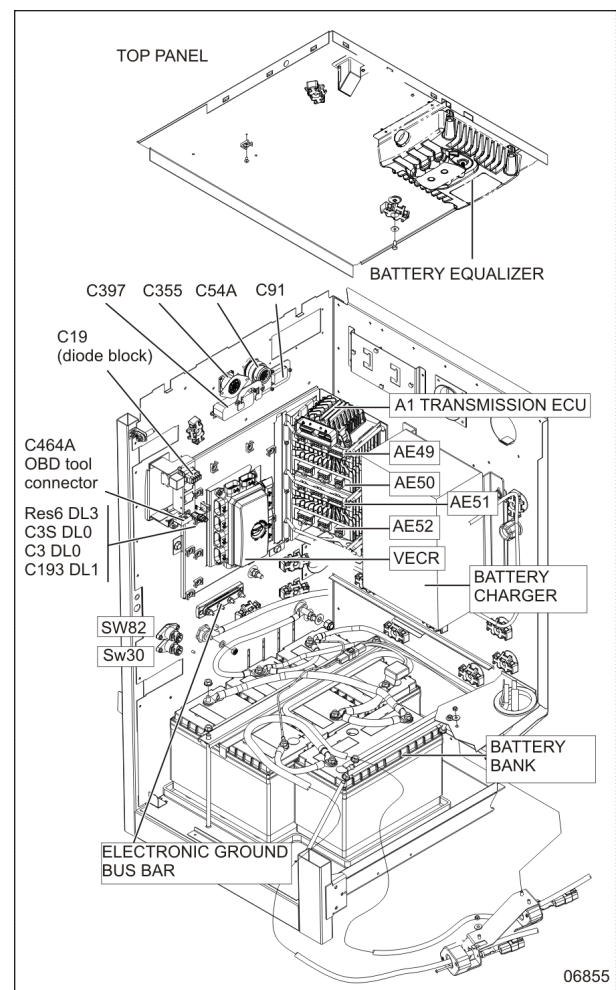

VIEW OF MAIN POWER COMPARTMENT (TYPICAL)

## 2-8 Coach Exterior

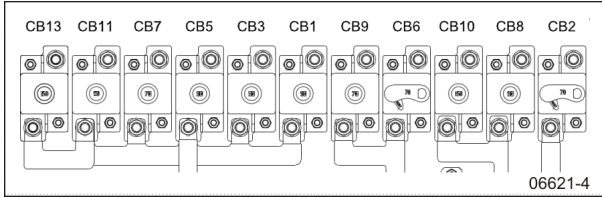

MAIN CIRCUIT BREAKERS 12 & 24 VOLTS (TYPICAL)

### RADIATOR DOOR

Open the engine compartment rear door to access the engine radiator door release handle.

Open the engine radiator door by pulling on the latch release lever from inside the engine compartment left pillar.

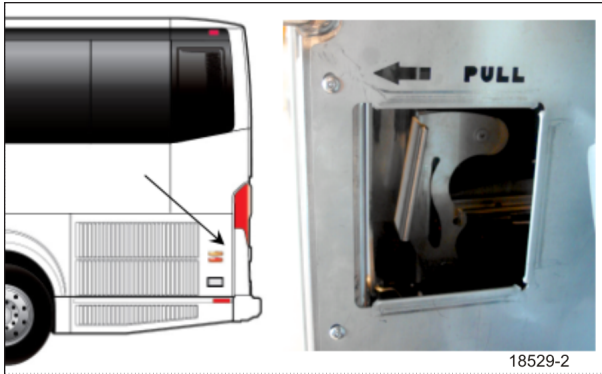

RADIATOR DOOR LATCH RELEASE LEVER LOCATION



### WARNING

WHEN THE ENGINE IS RUNNING...

Cooling fans may activate at any moment.

Keep hands away from cooling fans or keep the radiator door closed



### WARNING

Cooling fans may be running when the engine is shut down in the following conditions:

- If a High Exhaust Temperature condition exists (e.g. following regeneration). The CAC fans will keep running for a maximum of 15 minutes.
- During the electric Motor Test Sequence, the cooling fans will start running briefly.

### SCR CATALYTIC CONVERTER ACCESS HATCH

The hatch is located on the road side (left side) above the radiator door.

To gain access to the SCR catalytic converter:

1. Open the radiator door first;
2. Pull the catch connecting rod to unlock the access hatch;
3. Lift the hatch open;
4. Hold the door open by inserting the support rod free end into the receptacle.



### WARNING

After inserting the support rod into the receptacle, make sure the rod supports the door securely from falling down on to your head or body.



### WARNING

External and internal temperatures remain hot long after the engine has been shut down. Allow the Exhaust Aftertreatment System to cool before handling. Wear protective clothing and gloves while servicing.

### A/C CONDENSER COMPARTMENT

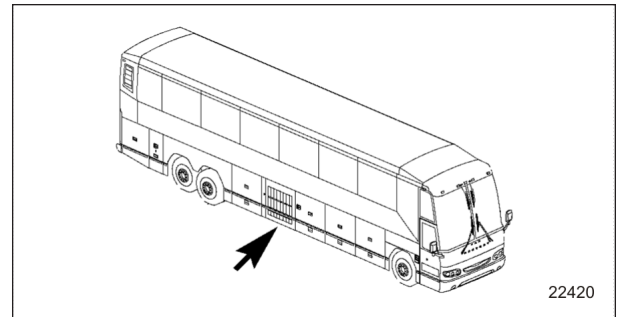

A/C CONDENSER COMPARTMENT



The following information is for vehicle equipped with a central A/C system.

To open the condenser compartment door:

1. Open the fuel filler door first;
2. Move the latch bolt pin to the right as shown (step 1 on image);
3. Rotate the latch handle as shown (step 2);
4. Open the door on the right side when facing it.

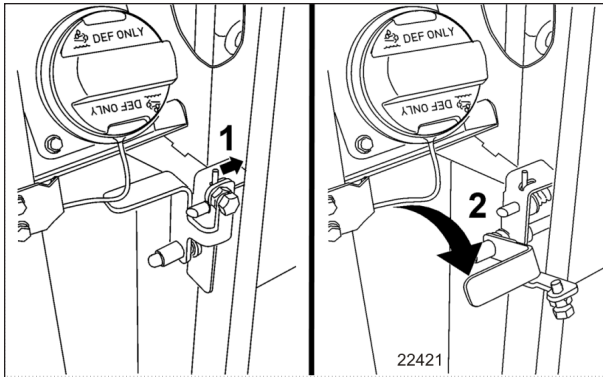

**A/C CONDENSER COMPARTMENT DOOR OPENING**

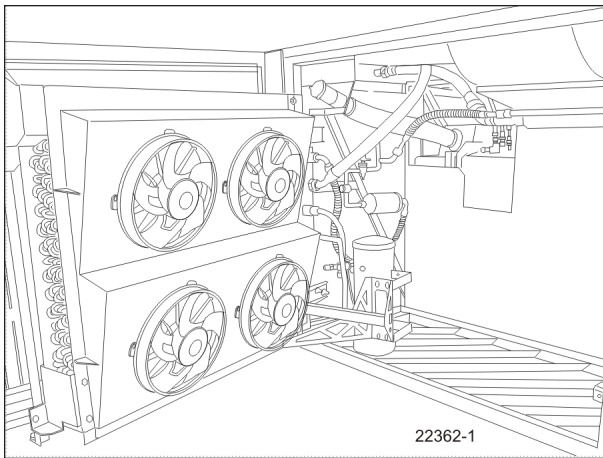

**CONDENSER COMPARTMENT**

**EVAPORATOR COMPARTMENT**

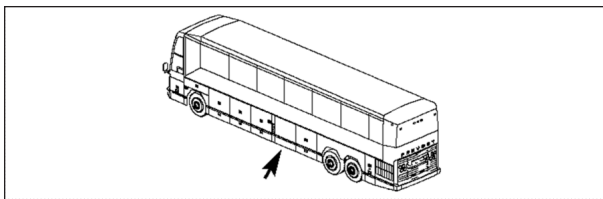

The following information is for vehicle equipped with a central A/C system.

To access the evaporator compartment, pull the release latch located on the left side wall of the rearmost baggage compartment.

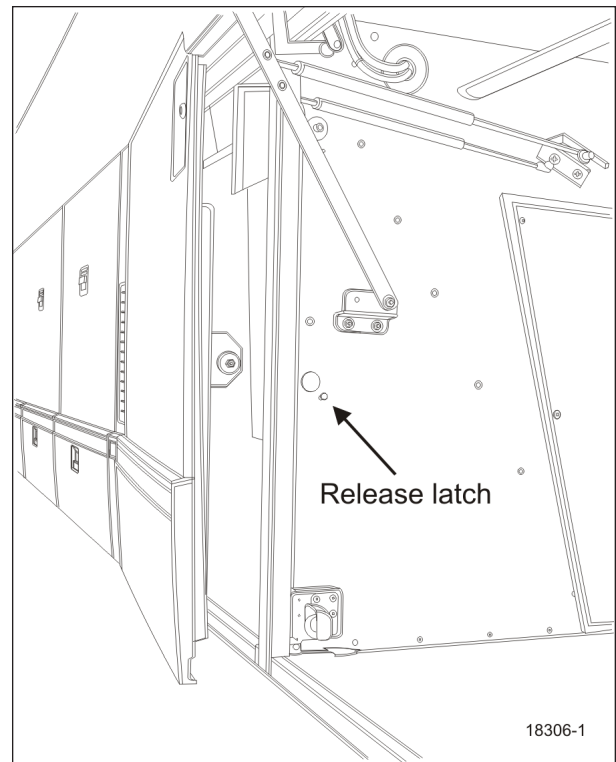

**EVAPORATOR COMPARTMENT ACCESS**

The evaporator compartment contains relays, diodes and a multiplex electronic module mounted on a panel located on the R.H. side wall when facing the compartment.

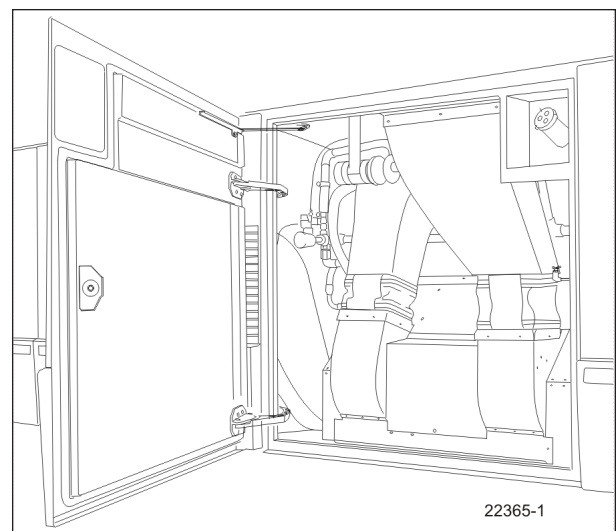

**EVAPORATOR COMPARTMENT**

## 2-10 Coach Exterior

### NOTE

It is important to keep the evaporator compartment door closed while checking the HVAC system to prevent faulty readings.

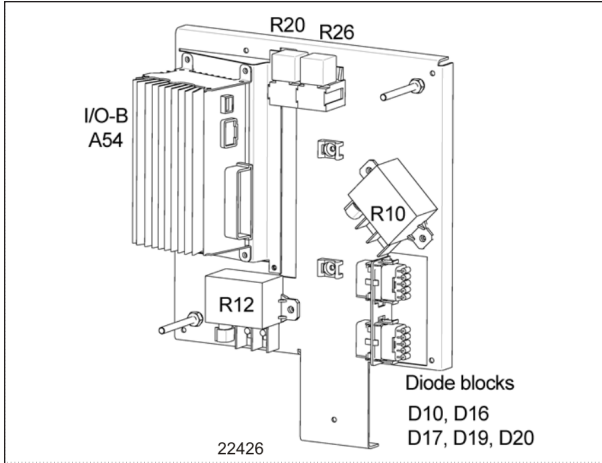

HVAC COMPONENTS PANEL

## FRONT ELECTRICAL AND SERVICE COMPARTMENT

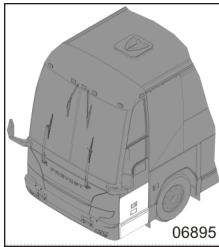

Unlock this compartment door using the exterior compartment key. The light in the front service compartment turns on automatically when the door is open.

The front electrical and service compartment provides access to the following:

- Front fuse box (VECF) & spare fuses
- ABS module
- VECU
- Front multiplex modules I/O-A, I/O-B
- Relays & resistors
- Kneeling audible alarm
- Emergency door opening unlock valve
- Windshield washer reservoir
- Headlights washer reservoir
- Reclining bumper opening handle
- Accessories air tank purge valve
- Accessories air tank fill valve

- MCM module
- Electronic ground stud
- Tire Pressure Monitoring System module
- Keyless module

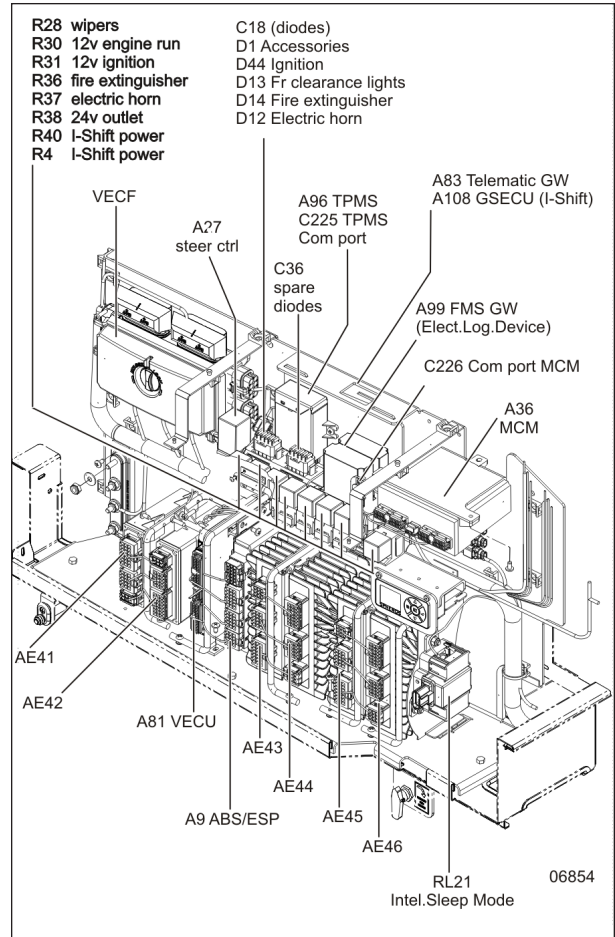

FRONT ELECTRICAL COMPARTMENT

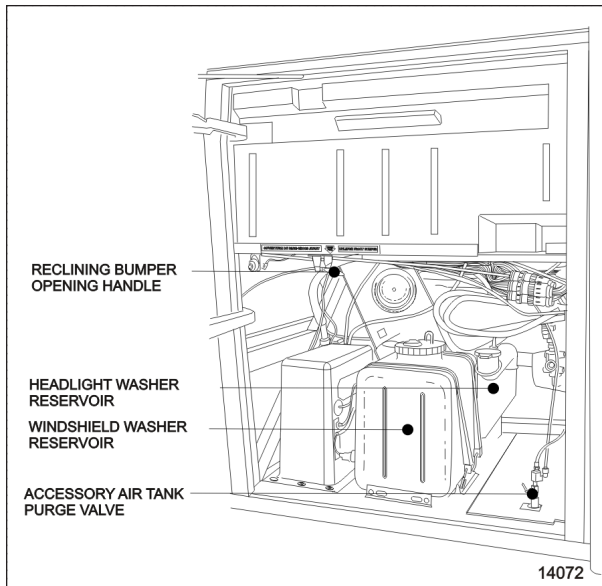

FRONT ELECTRICAL &amp; SERVICE COMPARTMENT

## BAGGAGE COMPARTMENTS

The baggage compartment doors can be locked and unlocked using the exterior compartment key. Lift up the cover to gain access to the lock. Pull up door handle to release the latch and then pull the door open. Pressurized cylinders assist the opening and closing of the baggage compartment doors and hold the doors open.

The lighting in the baggage compartments turns on automatically when the door is opened if the ignition key is set to ON or ACC.



### WARNING

To avoid injury, keep hands clear of door edge and door frame when closing

### NOTE

To prevent theft and vandalism, always lock all doors before leaving the vehicle unattended.

### NOTE

The baggage compartment doors can also be locked and unlocked using:

- The baggage compartments central locking system switch on the L.H. dashboard (refer to Controls and Instruments chapter).
- The keyless entry system.
- The remote entry transmitter (refer to Controls and Instruments chapter).

### NOTE

To prevent the door from closing in case of defective cylinders, lock the door in open position by pushing it further towards the body of the vehicle, until it locks in place.

## RECLINING BUMPER COMPARTMENT

The front bumper can be tilted downward to give access to the bumper compartment. Pull the release handle located inside front service compartment to unlock. Tilt down the entire bumper assembly to access the compartment. Push the bumper back up firmly in place to lock in position.

Check that bumper is securely closed shut before driving.

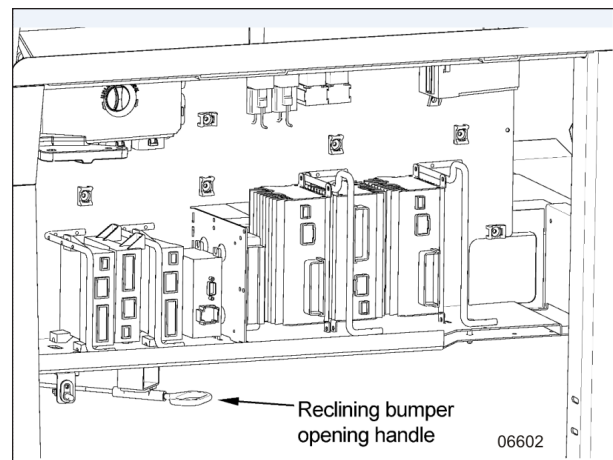

RECLINING BUMPER OPENING HANDLE



### WARNING

The compartment behind the bumper is not designed for miscellaneous storage. Never store loose objects in this compartment since they can interfere with the steering linkage mechanism.



### WARNING

Although a powerful spring assists in reclining the bumper, it remains heavy and rests low when open. Caution should be used when reclining.

## FUEL AND DIESEL EXHAUST FLUID (DEF) FILLER NECK ACCESS

These access doors must be opened with the exterior compartment key. To open, turn the key ¼

## 2-12 Coach Exterior

turn clockwise. Hold the door with your hand as you open the door. Open the street side filler neck access door to gain access to the DEF filler neck.

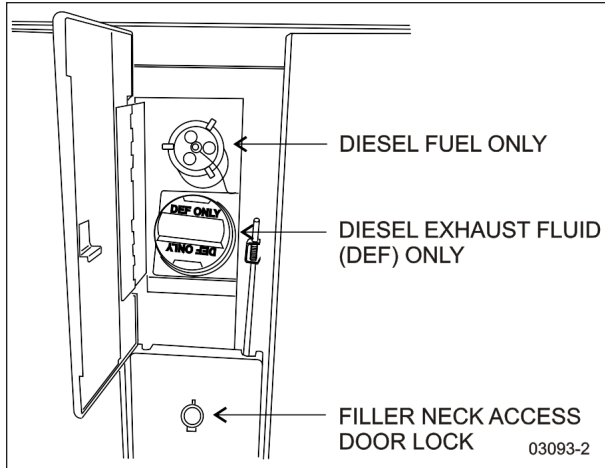

**STREET SIDE FUEL AND DEF FILLER NECK ACCESS**

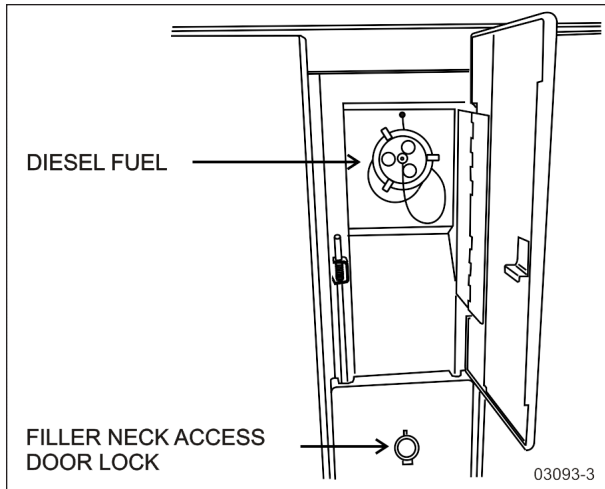

**CURBSIDE FUEL FILLER NECK ACCESS**

### **NOTE**

*Provided the vehicle is parked on level ground, an automatic nozzle will automatically shut off when tank is approximately 95% full.*



### **CAUTION**

Do not fill to more than 95% of the tank capacity. Do not "top off" the tank, doing so may result in fuel spillage when the fuel expands.



### **CAUTION**

#### **DEF – Do not overfill**

If an automatic nozzle is used for filling diesel exhaust fluid (DEF), do not add further DEF after the nozzle has automatically shut off flow a first time.

If such nozzle is not available, use the DEF level gage on the instrument panel to control the quantity during filling.

Diesel exhaust fluid DEF will begin to crystallize and freeze at 12°F (-11°C) and expand by 7% when frozen. To allow expansion without damaging the DEF tank, do not fill the tank with more than 16 gallons (60 liters).

During vehicle operations, the SCR system is designed to provide heating for the DEF tank and supply lines. If DEF freezes when the vehicle is shut down, start up and normal operation of the vehicle will not be inhibited. The SCR heating system is designed to quickly return the DEF to liquid form and the operation of the vehicle will not be impacted.

## **ENTRANCE DOOR**

### **OUTDOOR OPERATION**

Lock or unlock the entrance door from outside the vehicle by either turning the key in the door lock (counterclockwise to lock, clockwise to unlock), by using the outside key pad, or by using the remote control (electronic key). Open the door by pulling on the lever. Close by pushing the door shut.

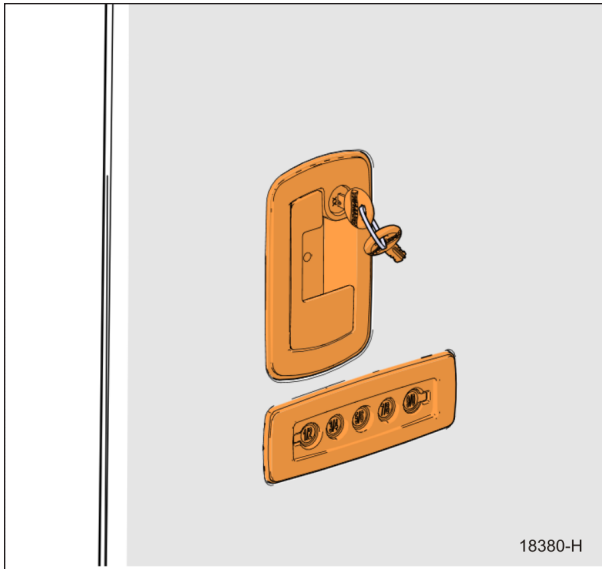

18380-H

**OUTSIDE LOCKING DEVICES****NOTE**

*The stepwell lights and entrance overhead light turn on as the door opens.*

**INSIDE OPERATION**

There are two ways of unlocking the entrance door from the inside. The first consists in actuating the rocker switch on the R.H. dashboard panel. This operation will also operate the baggage compartment locking devices.

It is also possible to unlock the entrance door by sliding its lock lever to the left.

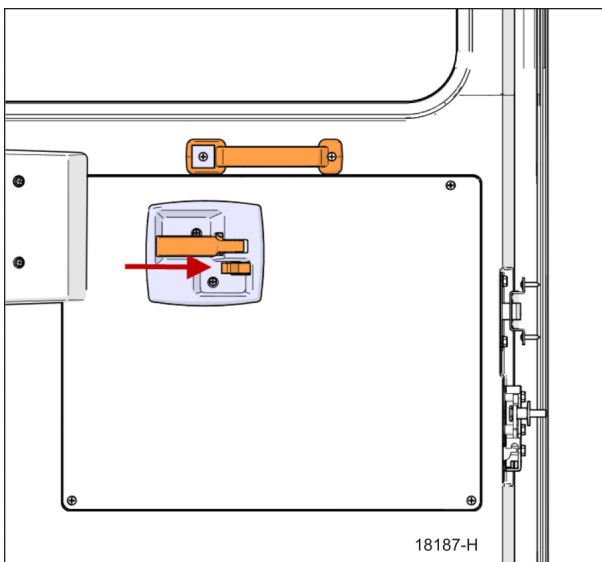

18187-H

**INSIDE LOCKING DEVICES****NOTE**

*If the alarm system is armed, unlocking the entrance door from the inside by sliding its lock knob will not disarm the alarm system. The alarm will sound.*

**NOTE**

*For complete information regarding the Keyless Entry System & Anti-theft Alarm System, refer to the document included in your vehicle's "publication box".*

**KEYLESS ENTRY SYSTEM**

This system, located below the entrance door handle, is used to lock or unlock the entrance door, the baggage compartment and the service compartment. A default 4-digit access code is permanently preprogrammed in the module by the manufacturer. A 6-digit authority code will also be supplied to the owner and will be used to store up to 40 new personal access codes (4-digit).

**NOTE**

*Refer to "Other Features" chapter for complete keyless system operating instructions.*

**EXTERIOR REAR-VIEW MIRRORS**

The vehicle is equipped with flat-type and convex-type rear-view mirrors. Convex mirrors give a wide-angle view. Objects viewed in convex-type rear-view mirrors appear smaller and are actually closer than they appear.

## 2-14 Coach Exterior

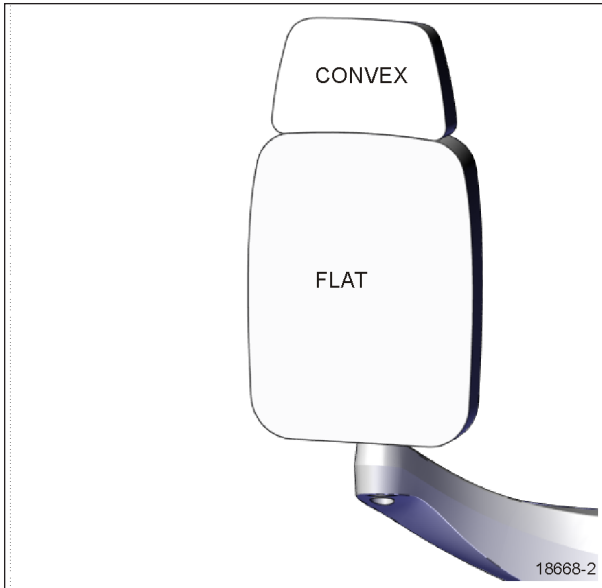

**EXTERIOR REAR-VIEW MIRROR**

To provide good visibility in cold weather, the mirrors can be equipped with heating elements. The elements are activated by a rocker switch located on the dashboard. Refer to "Controls & Instruments" chapter. Thermostats are used to prevent continuous operation of the heating elements.

### **CAUTION**

Do not attach stick-on type convex mirror accessories to the heated mirror glass. This could impede uniform heat distribution on the mirror surface and could break the mirror glass.

As an option, the mirrors may be equipped with LED turning signal lights to give an additional signal light when turning or changing lane for extra safety or for other drivers to see your signal when driving too close, in rain, fog or when in blind spot.

The mirrors are adjusted using the controls located on the L.H. control panel. Refer to "Controls & Instruments" chapter. Manual adjustment is also possible.

Adjust the side-view mirrors until the side of the vehicle is visible. Adjust the flat-type mirror until the road behind is in full view.

## **BACK-UP CAMERA**

An optional back-up camera is available which provides the driver with visual assistance when backing-up. The back-up camera is mounted in a housing with a retractable cover. For additional

information, refer to Controls and Instruments and Care and maintenance chapters.

### **NOTE**

A switch located in the rear electric compartment is used to retract the back-up camera cover for cleaning or maintenance.

### **CAUTION**

Never try force to rotate by hand the retractable cover. Damage may occur.

## **120-VOLT CONNECTOR**

This connector is used with a 120 volts supply and is connected to the optional engine block heater. Refer to Starting and Stopping Procedures chapter.

## **TRAILER HITCH**

Your vehicle may be equipped with a factory-installed trailer hitch which has been designed to meet the following rating:

**Maximum gross trailer weight:**

**20,000 lbs. (9072 kg)**

**Maximum tongue weight at 6 1/2 inches (165 mm) or less from coupling receiver:**

**1,500 lbs. (680 kg)**

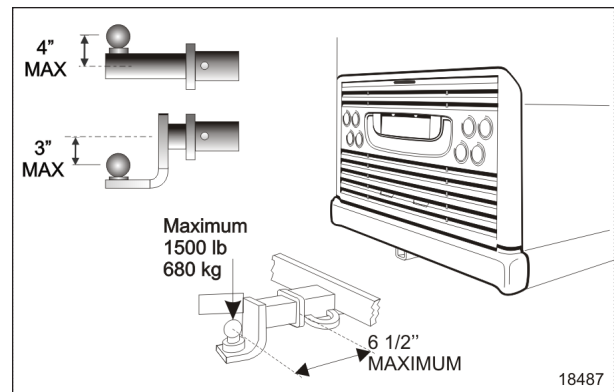

**TRAILER HITCH**

### **DANGER**

The draw bar and the ball used for towing the trailer should be rated for 20,000 lbs. capacity or more.

**WARNING**

Pulling a trailer weighing more than the recommended *maximum gross weight* may cause engine and transmission overheating, and a possible hitch failure.

**NOTE**

*Pulling a trailer over long distances is considered as a "severe operating condition" for the vehicle. The engine will require more frequent servicing.*

*socket, or the occurrence of a metal fracture of either coupling ball or coupling assembly, which results in separation of the ball from the coupling ball socket.*

4. Two lengths of safety chain shall be used. The strength rating (minimum breaking force) of each individual chain and its connecting means shall be equal to, or exceed the trailer's Gross Weight Rating (GTWR).
5. Towing vehicle must be equipped with engine or transmission retarder. The engine or the transmission retarder on the vehicle must be functional at all time (to be inspected frequently).

**TRAILER HITCH LOAD**

The minimum requirement for a trailer weighing up to 20,000 lbs. when coupled to a 20,000 lbs. Prevost Trailer Hitch is as per the following:

1. Trailer must comply with **Federal Motor Carrier Safety Regulations 393.52** regarding trailer braking capability.
2. The trailer coupling attachments must meet the following minimum static test load requirements. Use the indicated Gross Trailer Weight Rating (GTWR) of your trailer and multiply by the indicated value below.
  - Longitudinal tension and compression: (1.5 x GTWR)
  - Transverse thrust: (0.5 x GTWR)
  - Vertical tension and compression: (0.5 x GTWR)

*Loads indicated must be applied without incurring loss of attachments or distortion or failure which could affect the safe towing of trailer.*

3. The ball and trailer coupling must meet the following minimum test load requirements without incurring failure. Use the indicated Gross Weight Rating (GTWR) of your trailer and multiply by the indicated value below.
  - Longitudinal tension and compression: (GTWR x 3)
  - Transverse thrust: (GTWR x 1)
  - Vertical tension and compression: (GTWR x 1.3)

*In this case, failure is identified as the point at which the coupling or ball will accept no additional test load without separation of the ball from the coupling ball*

