

PREVOST

Instruction Sheet

IS-04063A

CONDENSER (XL, XLII & H3) AND EVAPORATOR FAN (H5-60) DRIVE MOTOR REPLACEMENT

REVISION : A

Kit #453626 (H5-60) is not necessary anymore, use kit #453624 instead.

Note: This instruction sheet replaces Is-00051A (Ref. ECN2000051 & ECN2004063).

MATERIAL

Kit #453624 includes the following parts:

Part No.	Description	Qty
453685	SHIM	1
453686	SHIM	2
453687	SHIM	1
500462	WASHER, FLAT 5/16 X 1 ½	6
563595	TAB RECEPTACLE TERMINAL 12-10 AWG-M/P 480	2
563596	TAB TERMINAL 12 AWG-M/P 480	2
563597	SEAL, PED CONNECTOR M/P 480	4
563599	CPA LOCK, PED CONNECTOR M/P 180 2 CIR.	1
563600	PED CONNECTOR M/P 480 2C SOCKET HOUSING	1
563601	PED CONNECTOR M/P 480 2C PIN HOUSING	1
563602	TPA LOCK, PED CONNECTOR M/P 480 2 CIR	2
563943	MOTOR T114 0.57HP, 24-VOLT DC, LONG SHAFT	1
IS-04063A	INSTRUCTION SHEET	1
FI-04063A	FEUILLE D'INSTRUCTION	1

Kit #453625 includes the following parts:

Part No.	Description	Qty
453685	SHIM	1
453686	SHIM	2
453687	SHIM	1
500462	WASHER, FLAT 5/16 X 1 ½	6
563454	MOTOR T114 0.57HP, 24-VOLT DC, SHORT SHAFT	1
563595	TAB RECEPTACLE TERMINAL 12-10 AWG-M/P 480	2

563596	TAB TERMINAL 12 AWG-M/P 480	2
563597	SEAL, PED CONNECTOR M/P 480	4
563599	CPA LOCK, PED CONNECTOR M/P 180 2 CIR.	1
563600	PED CONNECTOR M/P 480 2C SOCKET HOUSING	1
563601	PED CONNECTOR M/P 480 2C PIN HOUSING	1
563602	TPA LOCK, PED CONNECTOR M/P 480 2 CIR	2
IS-04063A	INSTRUCTION SHEET	1
FI-04063A	FEUILLE D'INSTRUCTION	1

PROCEDURE

Warning: Park vehicle safely, apply parking brake, stop engine and set battery master switch(es) to the OFF position prior to working on the vehicle.

1. Remove the drive motor protective cover. Disconnect the power supply cable connected to the drive motor screw terminals.
2. Dismount the drive motor and separate the fan from the shaft. Keep hardware for later use.
3. Using pliers, remove the power cable ring terminals.

Note: Before undertaking the next step, it is necessary to proceed to the following verification for H5-60 type vehicles. On that vehicle, some motors must have a CCW direction of rotation while other motors must have a CW direction of rotation. In order to validate the proper electrical connections, temporarily connect motor and run to check if the direction of rotation is as required.

4. On each wire, remove a piece of insulating sheath. Place a seal and then crimp tab or tab receptacle terminal (see the annexed instructions). Assemble connectors. Use figure 4, 5 & 6 as reference for proper electrical connections.
5. Fix the fans onto the shaft and install the new drive motor as per figure 1, 2 or 3 depending on the type of vehicle. Use the included shims or flat washers if needed to center the fan in the circular opening.

Note: On older vehicles, new motor base holes and support plate holes do not coincide so it is necessary to drill new holes in the support plate.

6. Fix the protective cover to #453687 shim where applicable. If more clearance is needed, shim the protective cover using flat washers.
7. Test the functioning of the system and check for proper direction of rotation.

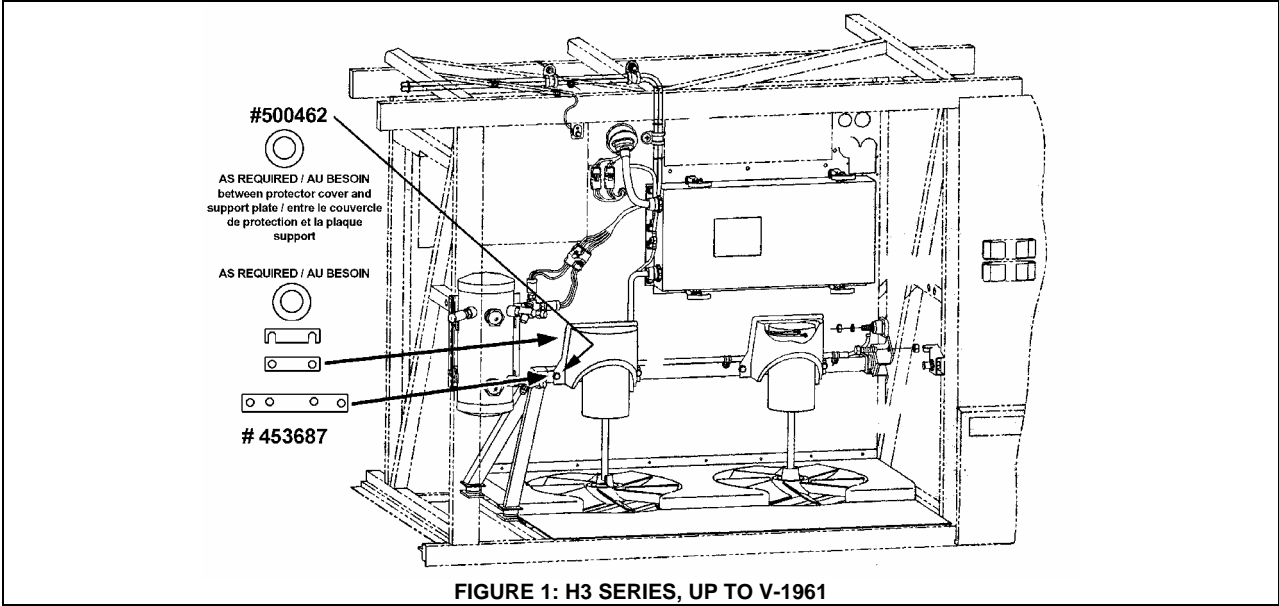

FIGURE 1: H3 SERIES, UP TO V-1961

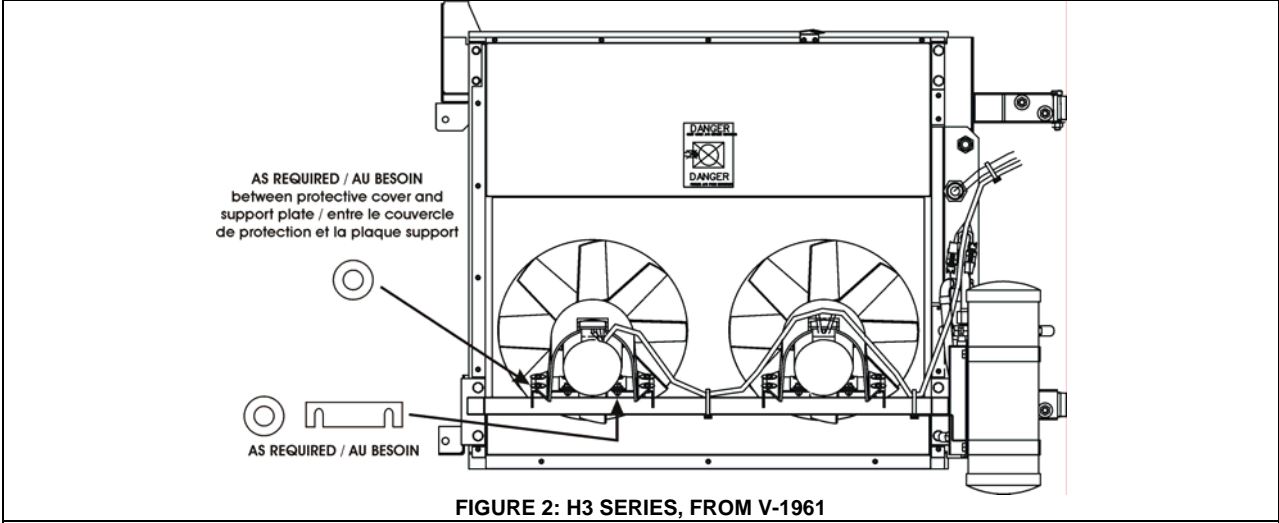

FIGURE 2: H3 SERIES, FROM V-1961

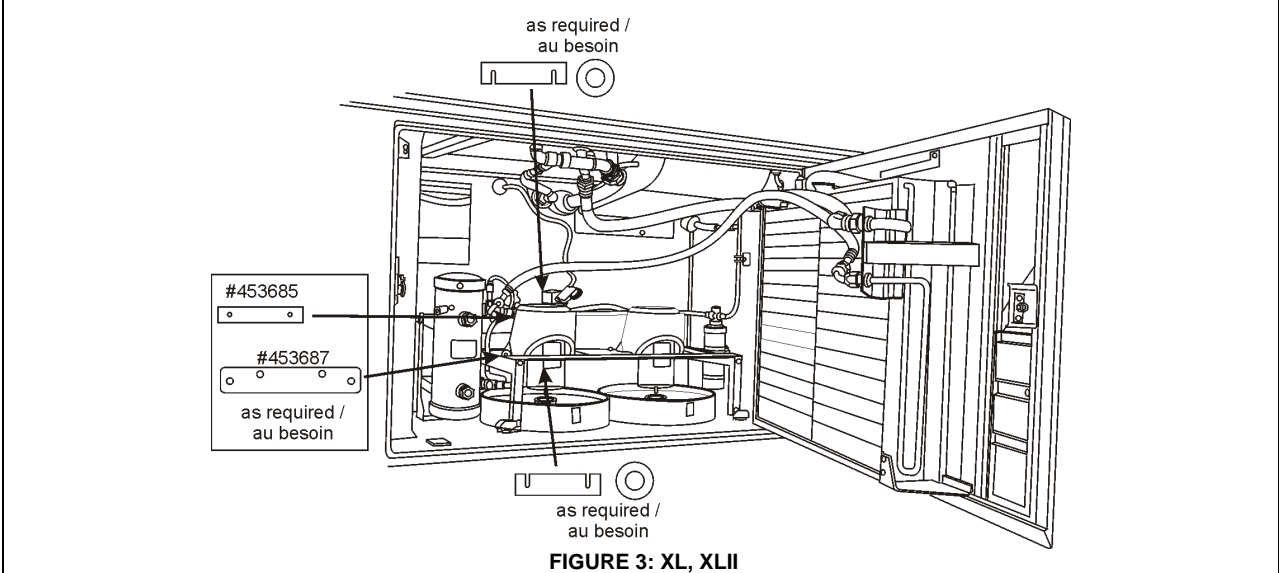

FIGURE 3: XL, XLII

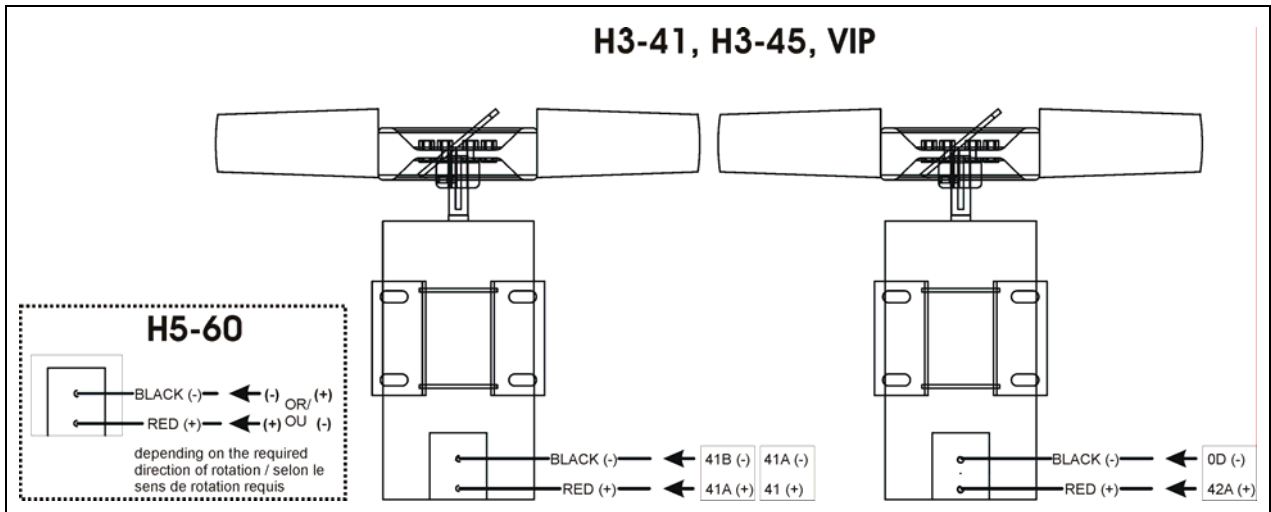

FIGURE 4: CONNECTIONS

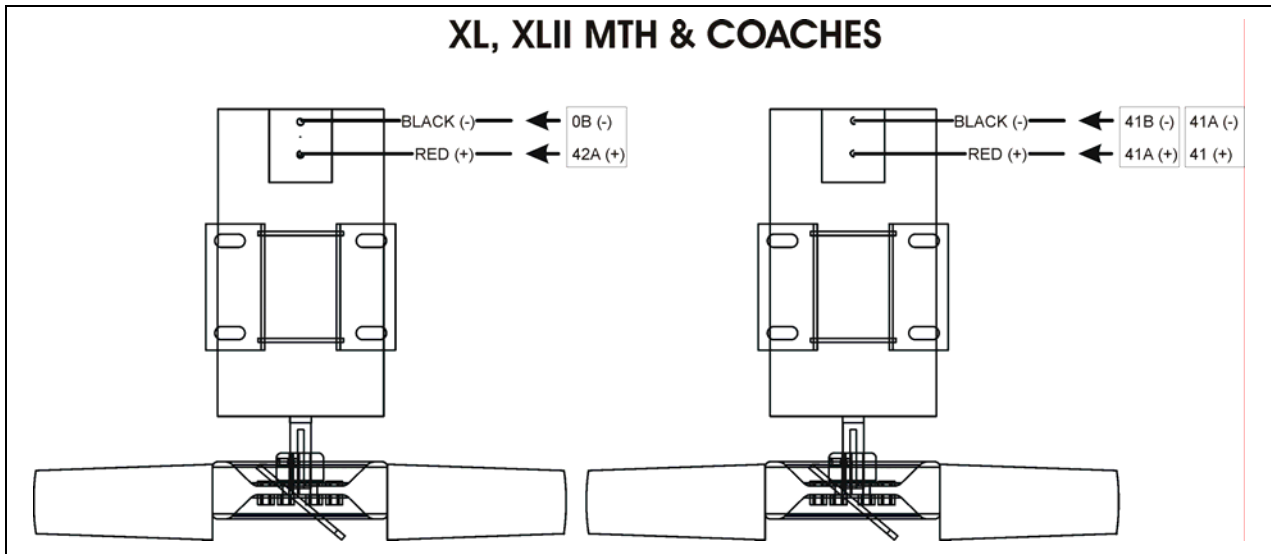

FIGURE 5: CONNECTIONS

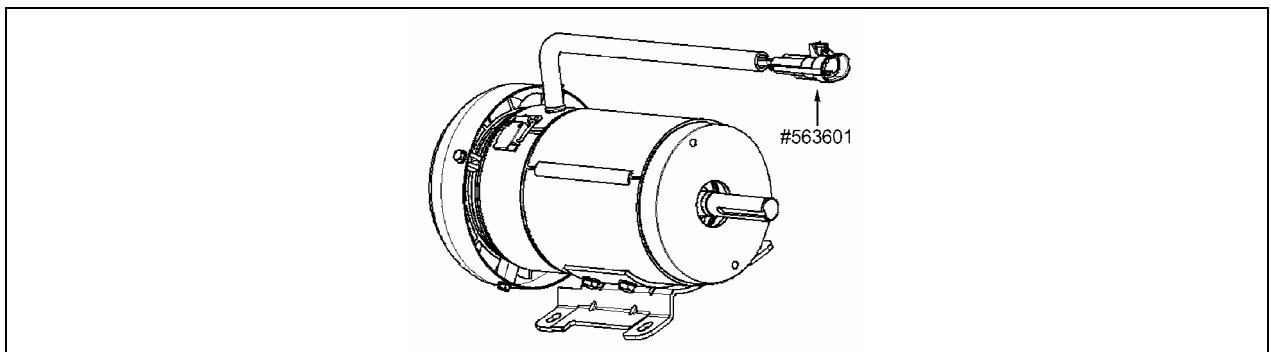
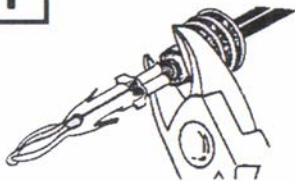

FIGURE 6: CONNECTIONS

TERMINAL REPLACEMENT SEALED WEATHER PACK AND METRI-PACK

1



CUT OFF TERMINAL BETWEEN
CORE AND INSULATION CRIMP.
(MINIMIZE WIRE LENGTH LOSS)
REMOVE SEAL

2



APPLY CORRECT SEAL PER GAUGE
SIZE OF WIRE. SLIDE BACK TO
ENABLE REMOVAL OF INSULATION.
STRIP 1/4" OF INSULATION.
**CAUTION MUST BE USED NOT TO
CUT STRANDS**

3



ALIGN SEAL WITH CABLE
INSULATION

4

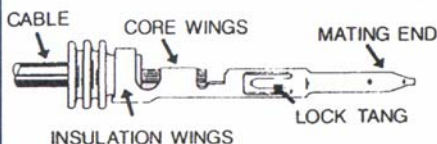

POSITION STRIP AND SEAL IN
TERMINAL AS SHOWN. CAUTION
MUST BE USED NOT TO POSITION
STRIP TOO FAR FORWARD. IT MAY
INTERFERE WITH MATING PORTION
OF TERMINAL.

TERMINAL REPLACEMENT SEALED WEATHER PACK AND METRI-PACK

(cont)

5



HAND CRIMP CORE WINGS FIRST, THEN INSULATION WINGS USING ONE OF THE APPROVED CRIMPING TOOLS. USE CRIMP MATRIX IN THE TABBED SECTIONS TO DETERMINE CORRECT TOOL COMBINATION.

6

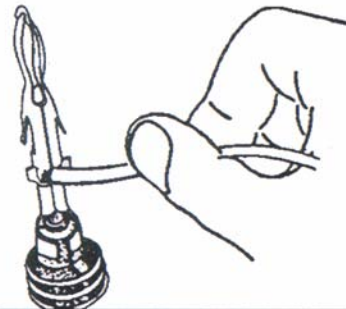

SOLDER ALL HAND CRIMPED TERMINALS.

CAUTION: USE EXTREME CARE ON ALL MICRO-PACK AND 150 METRI-PACK TERMINALS. AVOID SOLDER ON INTERFACE OR BOX AREA.

7

ELECTRICALLY CHECK REPAIRED TERMINAL FOR CONTINUITY.

USE J 39200-A MULTIMETER OR EQUIVALENT.

MAKE SURE TERMINAL IS REPLACED IN CORRECT CONNECTOR CAVITY TO ASSURE PROPER INDEXING.