

PREVOST

Instruction Sheet

IS-05903

MAINTENANCE REQUIRED ON EVAPORATOR MOTOR

MATERIAL

Kit # 453830 includes the following parts:

Part No.	Description	Qty
562951	Brush	4
680309	Stone, Brush seater and commutator cleaner (medium grade)	2
IS-05903	Instruction Sheet	1
FI-05903	Feuille d'instructions	1

PROCEDURE

WARNING

Park vehicle safely, apply parking brake, stop engine and set battery master switch(es) to the OFF position prior to working on the vehicle.

The evaporator motor is installed in the evaporator compartment (L.H. side of vehicle). It is a 27.5 volt, 2 HP (1.5 kW) motor which activates a double blower fan unit.

REMOVAL

1. Open the last L.H. side baggage compartment door. Pull the black release button located on the L.H. side in order to unlock and open the evaporator compartment door.
2. Identify the L.H. side discharge duct inside compartment and remove the Phillips head screws retaining the flexible member to duct.
3. Repeat step 2 for the R.H. side air duct.
4. Disconnect the discharge air sensor connector. Remove the cable tie securing wire.
5. From under the vehicle, remove the eight bolts retaining the evaporator fan motor support. Remove the complete unit from the evaporator compartment (Fig. 1).

CAUTION

Never support evaporator motor by its output shafts while moving it.

On a work bench, unscrew the fan square head set screws, the Phillips head screws retaining cages to support and slide out the assemblies from the evaporator motor output shaft.

INSTALLATION

To reinstall the evaporator motor, reverse "Evaporator Motor Removal" procedure.

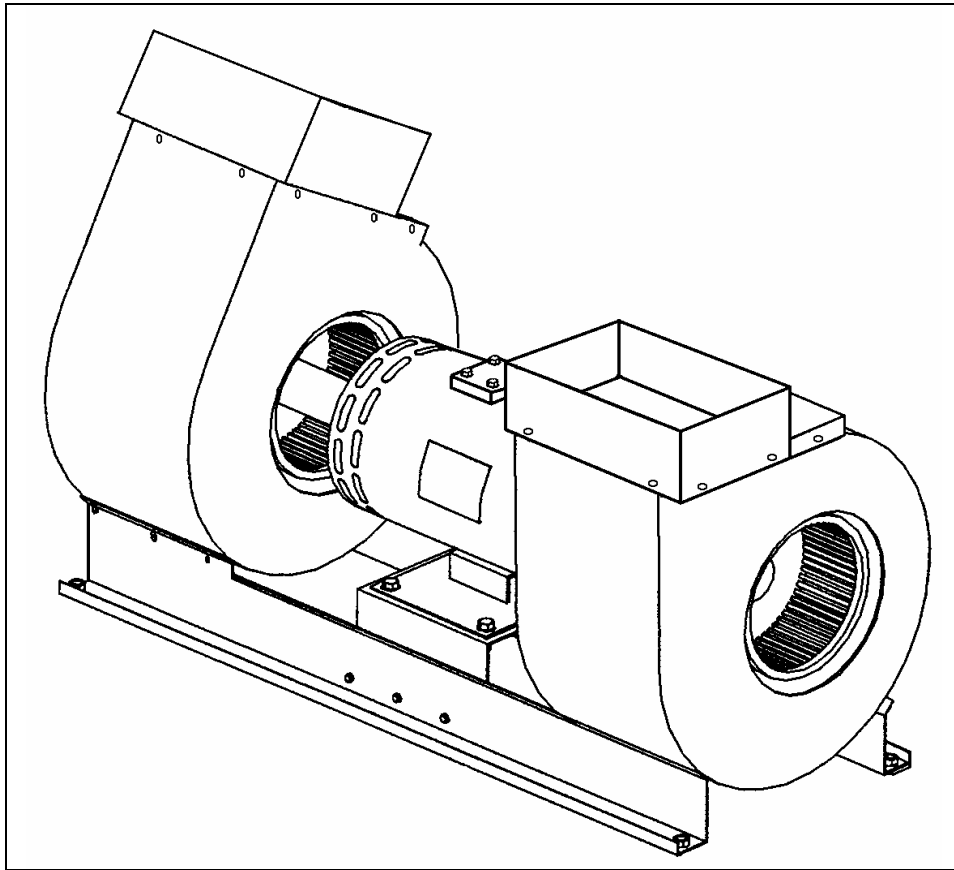

FIGURE 1: EVAPORATOR MOTOR ASSEMBLY

22208

CHECKING OPERATION OF BRUSH IN HOLDER

Lift brush slightly 1/8 inch (3 mm) and release it. Brush must produce a dry noise.

BRUSH WEAR INSPECTION AND REPLACEMENT



Only use replacement brushes recommended by the manufacturer. Not doing so will void warranty.

Replace the brushes if less than 3/4 inch (19 mm). New brush length is 1-1/4 inch.

To replace brushes, proceed as follows:

1. Set battery master switch to the "OFF" position.
2. Remove the protective screen band from the motor housing by pulling down the spring loaded fastener.
3. Lift the spring, remove and replace brushes as per the following procedure: "SEATING BRUSHES".
4. Reverse installation procedure.

SEATING BRUSHES

Grinding consists in giving to the seating face of a new brush the exact curve of the commutator or ring so that good mechanical and electric contact of the brush is ensured upon startup.

For best results, remove oil and grease from commutator before applying brush seater.

NOTE

The new motor brushes are provided with preformed seating face, i.e. with curved face machined with the required radius. This curve is only approximate and does not exempt further grinding. The advantage of preforming is to appreciably shorten the time required for grinding.

Grinding is generally done on the machine itself, in accordance with various processes' and conformably to the importance and the type of machines:

- a. Grinding with abrasive cloth medium grit (sandpaper) (grit 60) applied to a part of the commutator by hand. The new brushes installed in their brush holder and pressing against the cloth, one makes oscillate the rotor until complete grinding of the seating faces (Refer to figure 2). It is necessary to avoid raising the cloth under the brushes otherwise it would result, after grinding, to reduce and badly definite surfaces (Refer to figure 3).

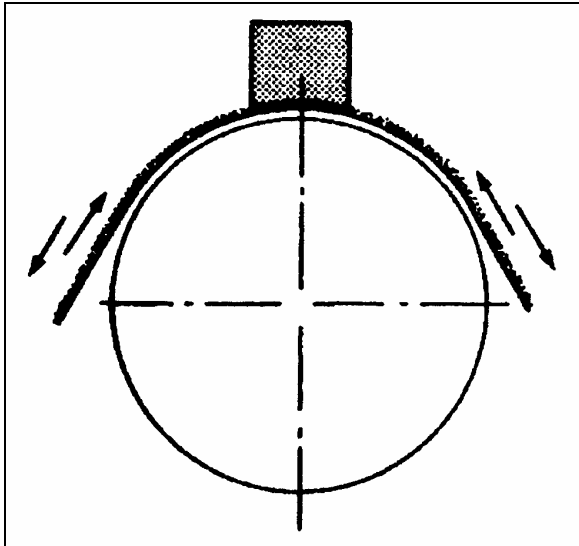

FIGURE 2

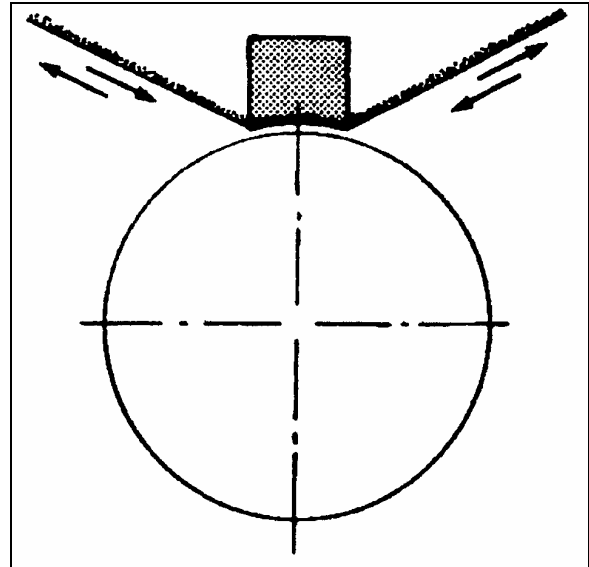

FIGURE 3

⚠ CAUTION ⚠

If grinding with a brush seater, you must disconnect the time delay in order to keep the motor in 1st speed. If you prefer, you may also install a jumper on the evaporator motor between terminal E2 and A1 to bypass relay R60 and keep the motor in 1st speed as well.

- b. Grinding with the brush seater stone is always done under no or much reduced voltage. Dust particles act like abrasive and wear down the brushes exactly with the profile of the commutator. **Do not misuse this method because grinding removes some metal from the commutator. It is applicable only to grinding requiring only reduced wear of the brushes.**

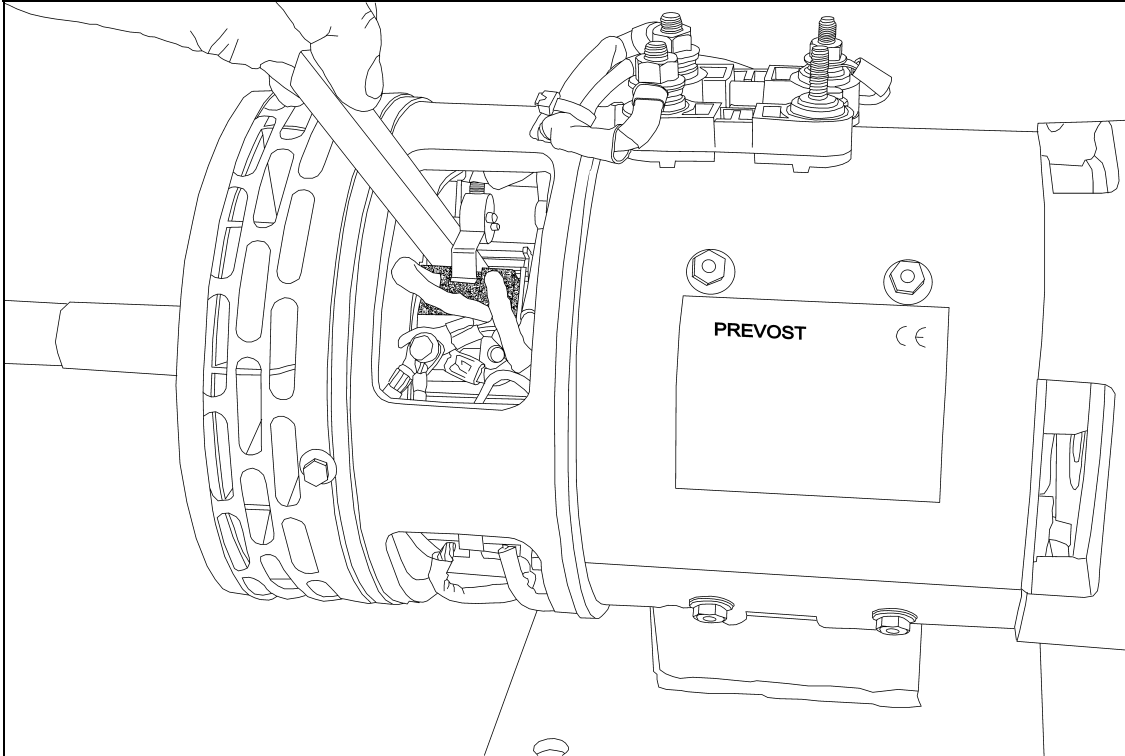

FIGURE 4

- c. Repeat method a or b until brushes are fully seated. **Seating surface of the brush must be no less than 80% of the face (Refer to figure 5).**

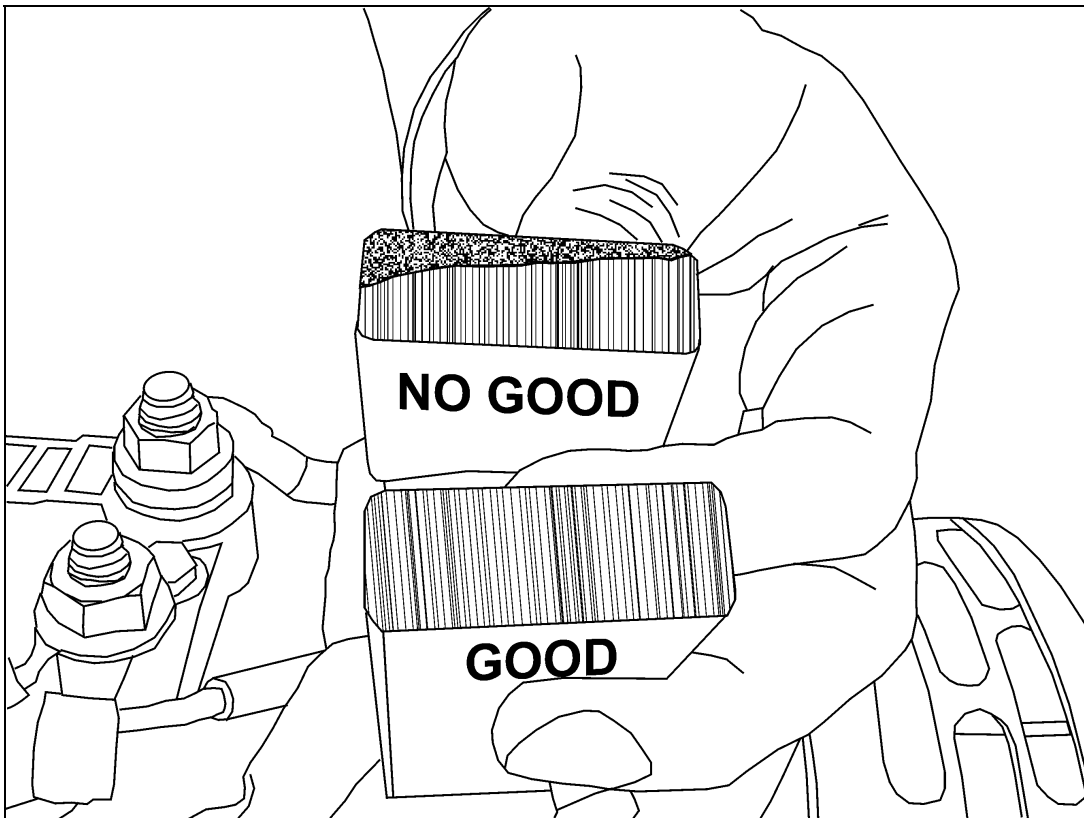

FIGURE 5

⚠ CAUTION ⚠

After grinding with the sandpaper or the seater stone, it is necessary to remove the brushes from the brush holders and vigorously clean with an air gun the commutator and the seating faces of the brushes to eliminate abrasive dust and dust from brushes.

⚠ WARNING ⚠

Use a dust mask to prevent inhalation of dust particles. Protect against electrical shock when working on energized equipment. Protect against falling or slipping when working on rotating equipment.

⚠ CAUTION ⚠

If grinding is not carried out or is carried out in an incorrect way, the brush may seat against a restricted zone only, which will support the entire load. The consequences risk to be serious for the commutator as for the brush and to seriously damage the motor.

After grinding is completed, it is necessary to check the evaporator motor amperage in 1st speed and in 2nd speed. **Make sure that the evaporator compartment door is closed and that the reading is 30 A ± 3 in 1st speed.**

Confirm that the reading is 64 A ± 4 (MAX 68 A) in 2nd speed.

BRUSH HOLDER ADJUSTMENT

NOTE

The brush holders are mounted on a support that can rotate. Rotating that rocker ring will move all the brush holders at the same time.

1. Remove the screws securing the grid and remove the grid. Locate the 2 bolts fixing the mechanism permitting the rotation of the brush rocker ring.
2. Loosen (do not remove) the bolts just enough to release the mechanism.
3. Move gently the exposed brush holder in order to have **30 A ± 3 in 1st speed and 64 A ± 4 in 2nd speed when the door is closed** and a maximum distance of 10 mm (3/8 inch) between the brush face and a reference line passing through the center of the 2 bolts on the motor housing.

⚠ CAUTION ⚠

If rotating the rocker ring is necessary, it is preferable to mark off the angular position of the rocker ring before unfastening the bolts fixing the mechanism in order to get back to the factory setting at the end of the operation.

NOTE

Take a final reading in 1st and in 2nd speed after tightening the brush holder bolts. The amperage may have changed.

⚠ CAUTION ⚠

To avoid damaging the motor, make sure all vehicle doors are closed when taking the readings.

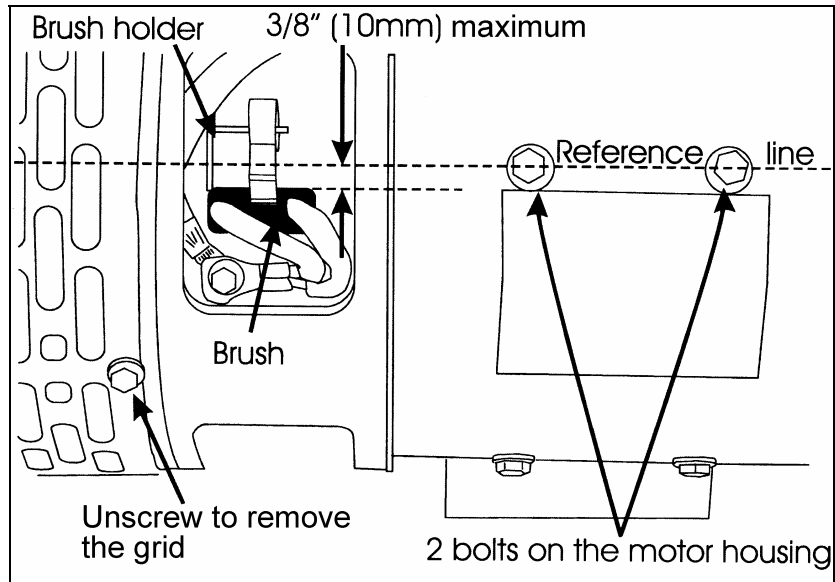

FIGURE 6: EVAPORATOR MOTOR

CHECKING COMMUTATOR

The surface must be polished. A brown-black colored surface is normal and indicates a good switching. Ensure there is no evidence of arcing or metal chips.