

Instruction Sheet

"CRUISAIR" AIR CONDITIONER

Description

The following instructions relate to the connection of a shutter to the "Cruisair" condensing units. Shutter will automatically open when "Cruisair" is on and will remain closed in all other cases. Shutter is normally opened and closed by air pressure.

Material

Gauge 16 approved stranded wires

125 V AC relay "Granger" #2W918 or equivalent

Relay socket "Granger" #5 x 852 or equivalent

12 V DC solenoid valve "Norgren" K41-EA00 KV2-KS6 or equivalent

NOTE: Solenoid valve must be provided with 3 ports to vent shutter cylinder when turning on A/C units.

Procedure

1. Install relay sockets at selected locations, then insert relays.

NOTE: Relays can be mounted inside the electric compartment of each A/C unit to provide some weather protection.

2. Install solenoid valve at selected location.

NOTE: Solenoid valve can be mounted on the forward side of one A/C unit for easy servicing.

3. Connect red wire on positive terminal of relay socket and with red wire on condensing unit terminal strip. Use an appropriate length of gauge 16 red wire, strip both extremities and crimp ring terminals. Refer to figure 1.

NOTE: When performing connection, make sure that condensing unit terminal number matches with relay number.

4. Connect white wire on negative terminal of relay socket and with white wire on condensing unit terminal strip. Use an appropriate length of gauge 16 white wire, strip both extremities and crimp ring terminals. Refer to figure 1.

5. Connect the 12 volt "house current" to the relay socket input. Use an appropriate length of gauge 16 wire, strip both extremities and crimp ring terminals.

NOTE: Do not use Prevost chassis battery system.

6. Connect the 12 volt relay output to the solenoid valve. Use an appropriate length of gauge 16 wire, strip both extremities and crimp ring terminals.

7. Connect solenoid ground wire to chassis.

8. Connect accessory manifold block air line to solenoid valve then from solenoid valve to air cylinder.

NOTE: Check that the air line is connected to the accessory manifold block.

9. Repeat steps 3, 4, 5 and 6 to connect other relay(s).

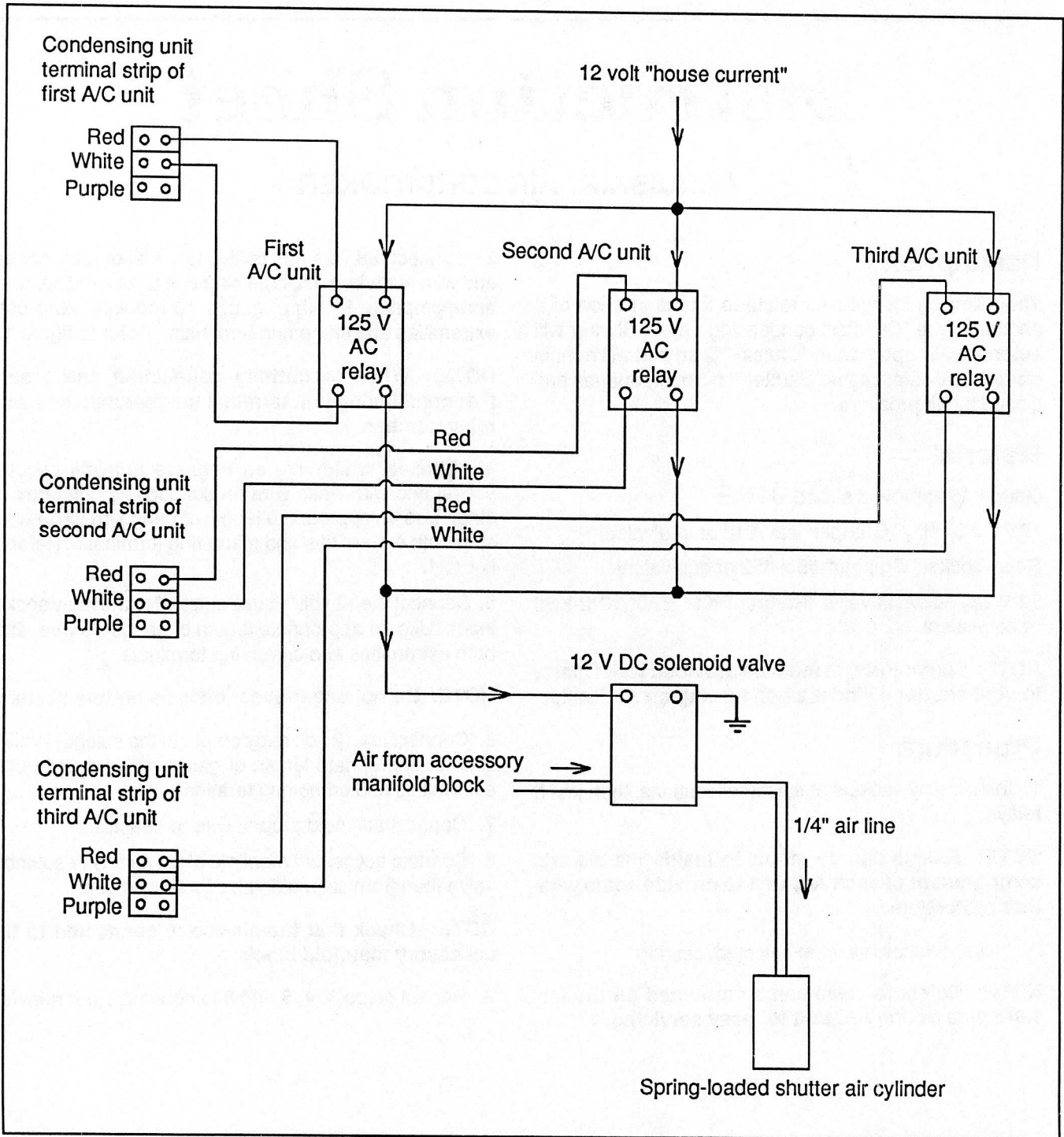

IS902201

Figure 1 - "Cruisair" condensing unit wiring diagram for operating Prevoist automatic shutter behind bumper