

Instruction Sheet

INSTALLATION OF A "QUICK-LOUNGE" SYSTEM IN A H3-40 COACH

Material

Part no	Description	Qty
-----	Hex head cap screw 3/8"-16 x 1"	16
-----	Flat washer 3/8" I.D.	16
-----	Lock washer 3/8" I.D.	16
-----	Hex head cap screw 5/16"-18 x 1 1/2"	16
-----	Hex head cap screw 5/16"-18 x 1"	50
-----	Countersunk head cap screw 5/16"-18 x 3/4"	8
-----	Hex nut 5/16"- 18	8
-----	Flat washer 5/16" I.D.	70
-----	Lock washer 5/16" I.D.	24
-----	Wood screw #10 x 1"	8
-----	Wood insert (Murakoshie) 1/4"-20	1
-----	Hex socket head cap screw 1/4"-20 x 1"	1
36-2627	Floor rail fastener	16
36-2355	Wall rail fastener	16
86-0702	L-shape table assy (12" wide)	1
86-0697	L-shape table assy (6" wide)	1
-----	Rectangular table stand	2
86-0655	Rectangular table shelf	2
86-0654	Straight seat module	4
86-0653	Corner seat module	2
-----	Seat module support	8
-----	Longitudinal finishing panel	2
86-0701	End finishing panel	1
IS-91770	Instruction Sheet	1
FI-91770	Feuille d'instructions	1

NOTE: On vehicles where card tables have to be relocated, kit #36-3083 consisting of fasteners and a special card table bracket is required to fit card table to its new position. One kit is required per card table.

Procedure

NOTE: To ease assembly, refer if need, to the illustration on promotional sheet annexed, showing Quick-Lounge system final set-up mounted in a "Le Mirage" coach. (There are only slight differences between a "Le Mirage" and "H3-40" Quick-Lounge set-up).

1. Park vehicle safely, then set battery main disconnect switches to the "OFF" position.
2. Disconnect the aisle lamp mounted under the last but one row of seats on the L.H. side.
3. Remove the 3 last rows of seats on each side of vehicle.
4. Remove the seat pedestals and the seat pedestal fasteners from floor rails. To remove fasteners, first remove the rail covers located in the quick lounge area.
5. Cut an opening in the floor rail to enable removal of seat pedestal fasteners. Perform the opening under the trash container on the right side and close to vehicle back wall on the left side. Cut the opening just large enough to ease installation and removal of fasteners.

NOTE: On some vehicles, it is possible that openings have been performed at factory.

6. Insert (8) floor rail fasteners in each rail opening.
7. Referring to measures given in figure 1, position approximately the (8) seat module supports.
8. Attach each seat module support to wall rail using (2) wall rail fasteners, 5/16" x 1 1/2" bolts, flat and lock washers. **DO NOT TIGHTEN.** Refer to figure 2 to correctly assemble support to wall rail.

NOTE: Attach the last L.H. support to wall rail using the same fasteners even if rail configuration is different.

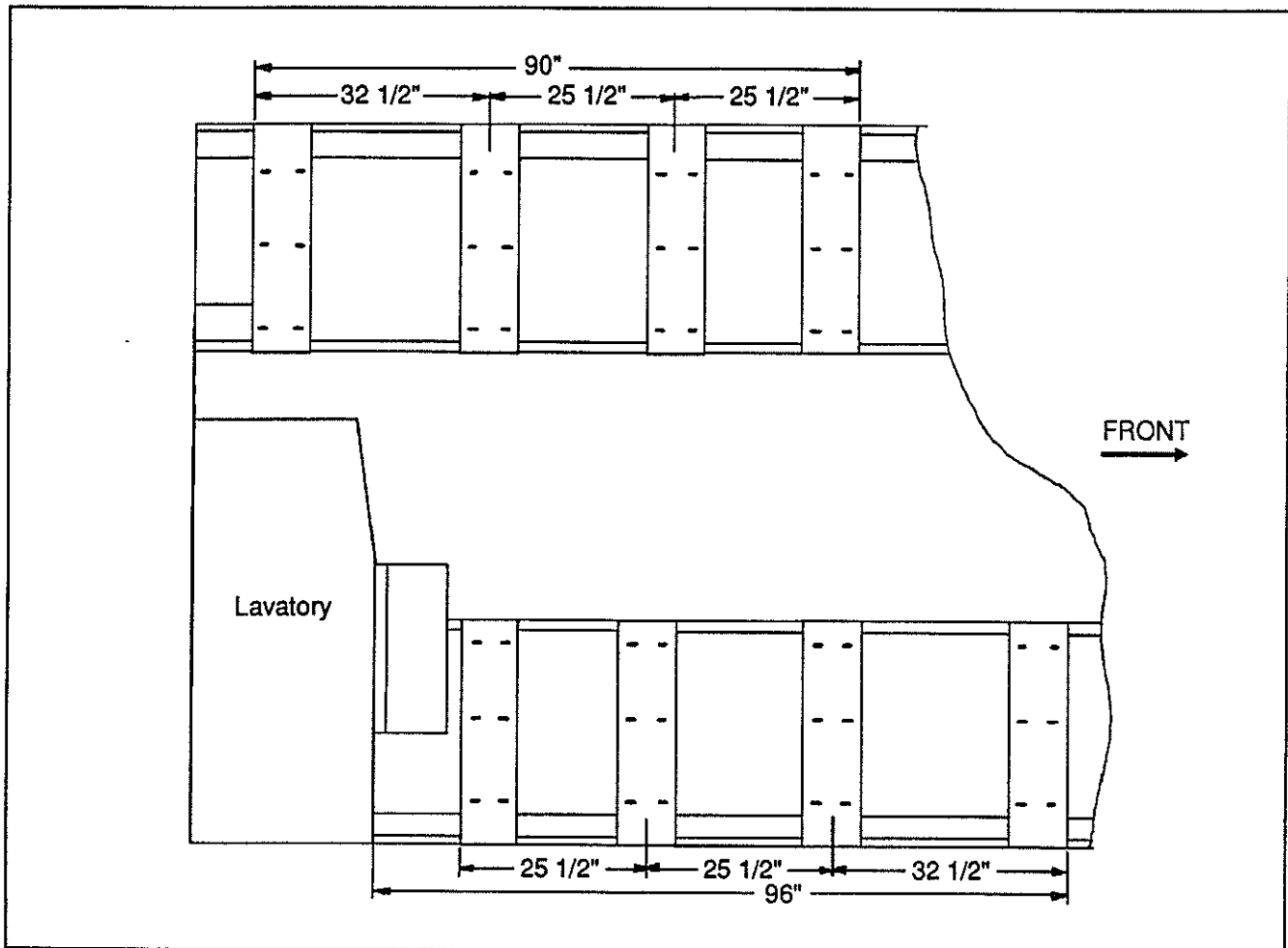

Figure 1 - Seat module supports lay-out (Top view)

IS917701

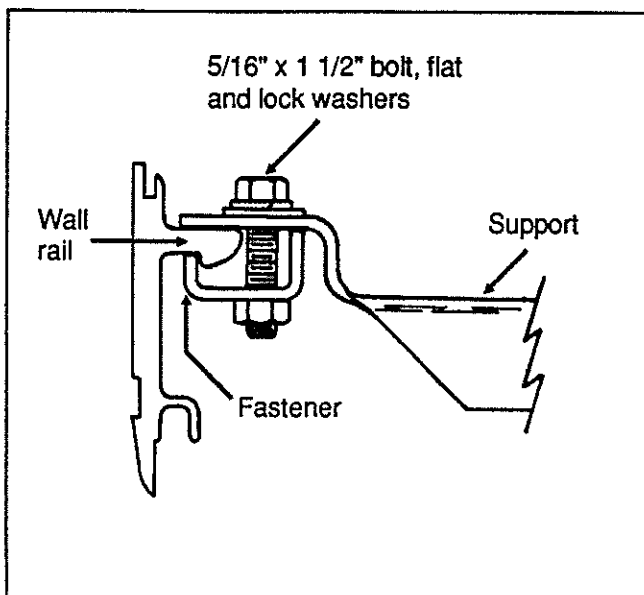

Figure 2 - Installation of support to wall rail

IS917702

9. Attach each seat module support to floor rail using (2) floor rail fasteners (previously inserted in rail), 3/8" x 1" bolts, flat and lock washers. **DO NOT TIGHTEN.**

NOTE: Be sure vehicle is parked at level before to proceed with following step.

10. Position L-shape table assy (12" wide) over trash container, align table stand flush with floor rail (refer to fig. 3), then using table bracket as a template, mark position of hole to drill on lavatory wall. Be sure to keep table at level while marking.

11. Remove L-shape table assy then make a slight horizontal incision (about 1/2" long) in wall carpet just over and under hole to drill.

12. Drill a 1" (25,4 mm) deep blind hole using a 19/64" (7,5 mm) drill bit.

13. Screw the wood insert (Murakoshie) in blind hole.

14. Reposition L-shape table assy, attach table bracket to lavatory wall using the 1/4" x 1" hex socket head cap screw. **DO NOT TIGHTEN.**

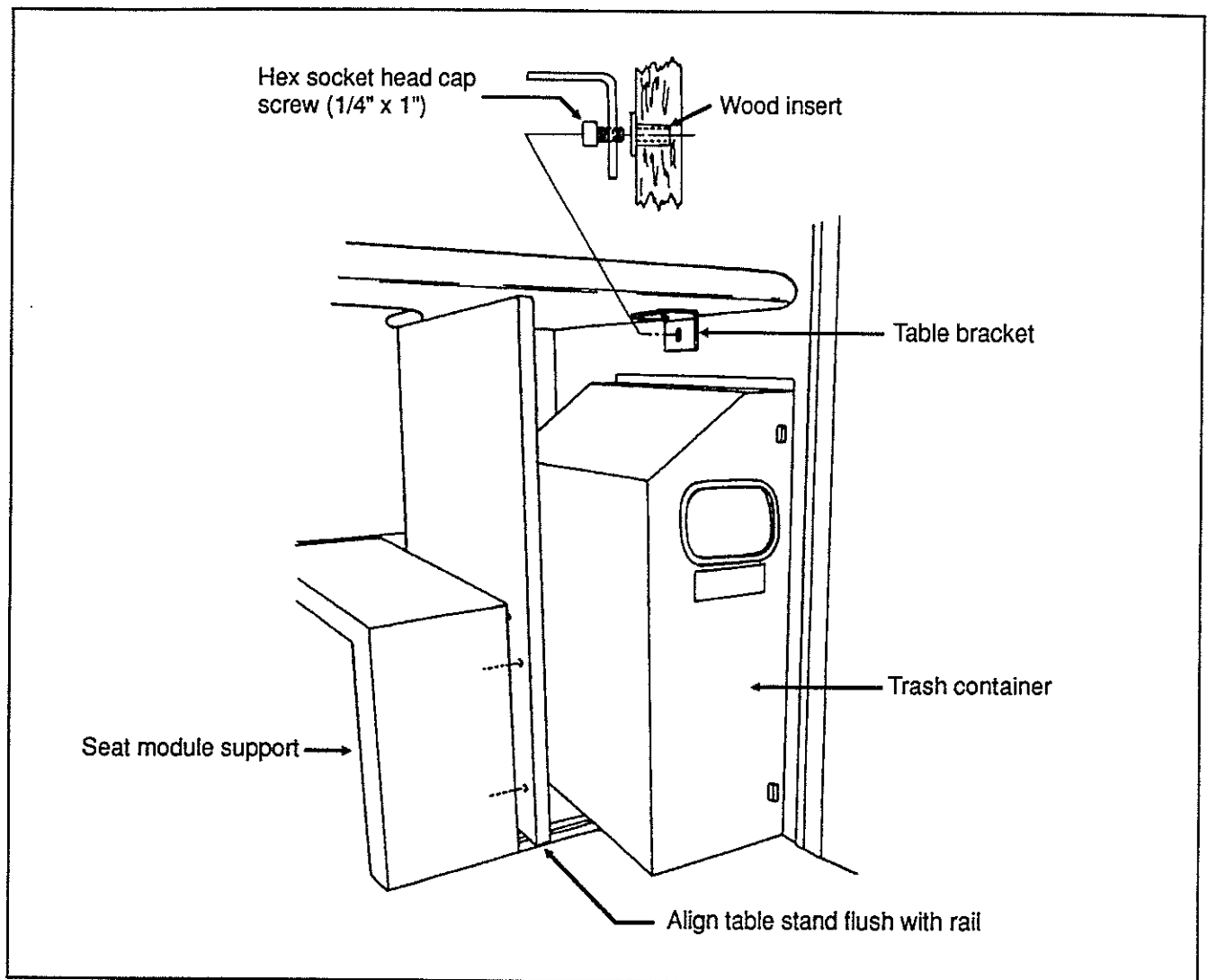

Figure 3 - L-shape table assy (12" wide) Installation

IS917703

15. Attach L-shape table assy to seat module support using (5) 5/16" x 1" bolts and flat washers. Tighten adequately.

16. Complete tightening the (2) bolts retaining seat module support to wall rail then the one retaining table bracket to lavatory wall.

17. Position L-shape table assy (6" wide) then fix it to seat module support using (5) 5/16" x 1" bolts and flat washers. Tighten adequately.

NOTE: Do not tighten at this stage fasteners retaining seat module support to wall rail and floor rail, as support will need to slide according to straight seat module position.

18. Position a straight seat module over the 2 last R.H. side supports, then from underneath, fix seat module to supports using (3) 5/16" x 1" bolts and flat washers per support. Tighten adequately.

NOTE: The straight seat module must occupied only the half-section of the last but one support as remaining section will be occupied by the second straight seat module.

19. Complete tightening fasteners retaining the last but one R.H. seat module support to wall rail.

20. Position the second straight seat module next to the first one, and from underneath, attach seat module to supports using (3) 5/16" x 1" bolts and flat washers per support. **DO NOT TIGHTEN.**

21. Mount an appropriate C-Clamp against the second and third seat module support (see fig. 4) then screw it to obtain the best possible fit between seat modules.

22. Complete tightening fasteners retaining seat module to seat supports then those retaining support to wall rail, remove C-Clamp.

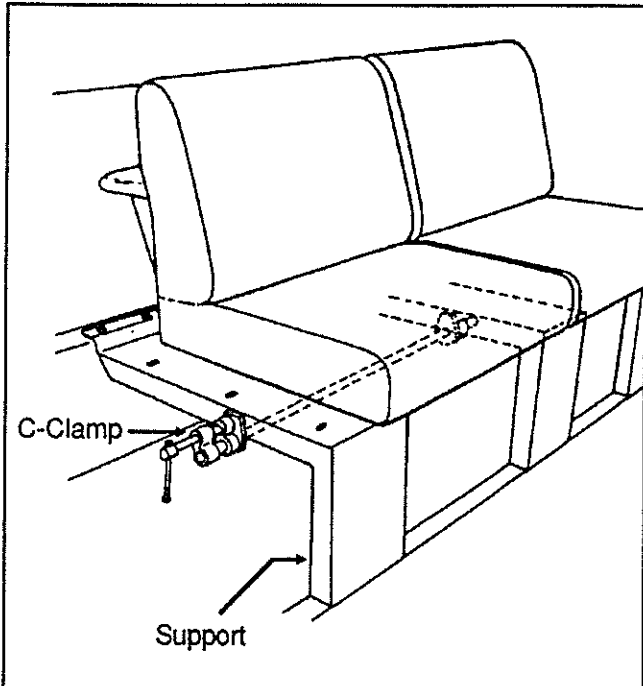

Figure 4 - Straight seat module Installation IS917704

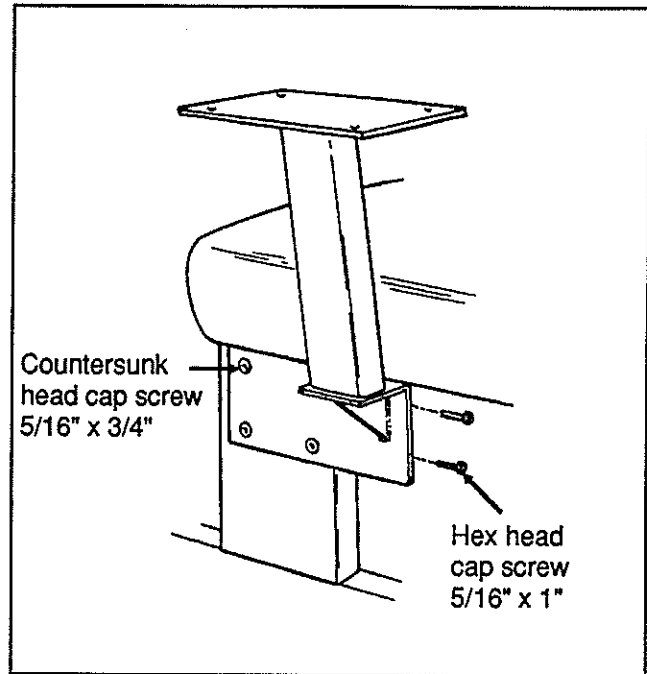

Figure 5 - Table stand Installation IS917705

23. Position corner seat module then repeat previous steps to fix it.
24. Repeat installation sequence to mount L.H. seat modules starting with corner seat module.
25. Complete tightening fasteners retaining each seat module support to floor rail.
26. Position rectangular table stand against seat module support as illustrated in figure 5, attach loosely using (4) 5/16" x 3/4" countersunk head bolts, nuts, flat and lock washers then (2) 5/16" x 1" bolts.
27. Position shelf over table stand, align it with corner table using a straight edge as illustrated in figure 6, then fix it to table stand using (4) #10 x 1" wood screws.
28. Adjust table shelf to level with corner table then complete tightening fasteners retaining stand to seat support.
29. Repeat previous steps for the installation of the second rectangular table.

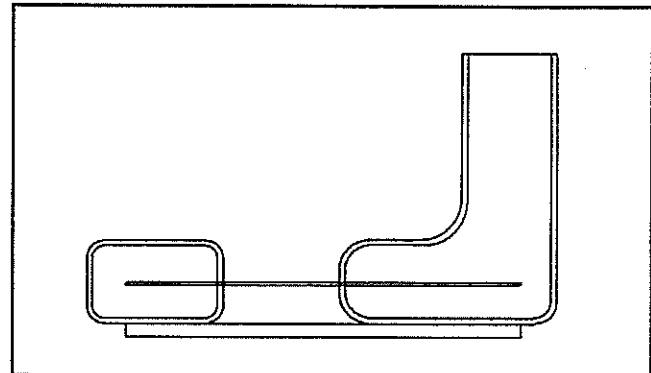

Figure 6 - Rectangular table alignment (Top view) IS917706

30. Peel off protective paper from "Velcro" pieces mounted at back of longitudinal finishing panel, position panel under seat modules then push firmly on panel to allow sticking face of "Velcro" to stick on seat module supports.
31. Repeat previous step for the installation of the second longitudinal finishing panel then for the end finishing panel.

REVERSE INSTALLATION PROCEDURE TO REMOVE QUICK-LOUNGE SYSTEM AND INSTALL SEATS.