



PREVOST

SAFETY RECALL

Sr00-25

ENREGISTRÉ - REGISTERED
ISO 9001 & ISO



DATE : September-2000	SECTION : 22
SUBJECT : MISSING COMBUSTION CHAMBERS IN WEBASTO COOLANT HEATERS	

APPLICATION

All vehicles with **Webasto DBW 2010, 45000Btu** Coolant Heater among the following

Model	VIN	
XLII-45 Coaches Model Year : 2000 – 2001	From 2PCX33490Y1027117 up to 2PCX3349011027379 incl.	
H3-41, H3-45 Coaches Model Year : 2000 – 2001	From 2PCH33496Y1013484 up to 2PCH3349711014035 incl.	

DESCRIPTION

It has come to the attention of Prévost Car Inc. that some Webasto DBW 2010, 45000Btu Coolant Heaters may have been shipped to vehicle manufacturers without a Combustion Chamber (a.k.a. Burner Tube) assembled in them. This notice encompasses all new DBW 2010 Coolant Heaters manufactured beginning **October 1999 through April 2000 (find the manufacturing date on a round sticker affixed on the burner). See label on top of burner for model, ID number and serial number.**

SITUATION

When a unit is defective, a flame will be noticed exiting the exhaust pipe at the bottom of the unit. Damage to the heater and the vehicle in which it is installed is possible if a DBW 2010 Coolant Heater is missing a combustion chamber.

MATERIAL

Order the following part :

Part No.	Description
871128	Combustion chamber for Webasto DBW 2010 Coolant Heater

Note : Material can be obtained through regular channels.

PROCEDURE

Warning : Park vehicle safely, apply parking brake, stop engine and set battery master switch(es) to the OFF position prior to working on the vehicle.

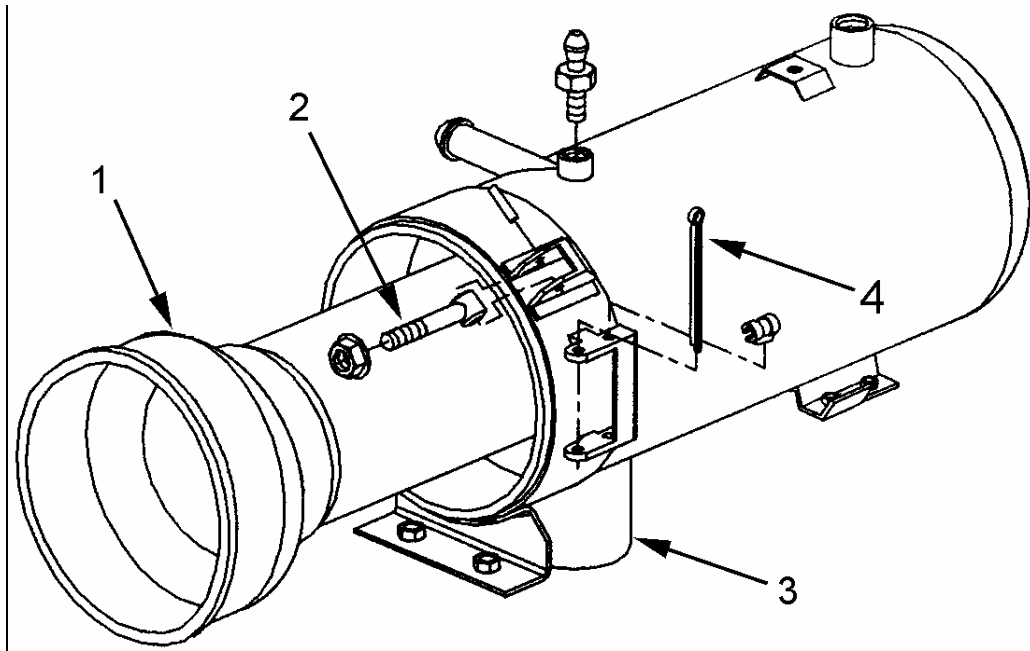

FIGURE 1 : HEAT EXCHANGER SIDE OF WEBASTO DBW 2010 (BURNER NOT SHOWN)
 1 : combustion chamber, 2 : eye bolt, 3 : exhaust pipe , 4 : cotter pin

VERIFICATION

1. Locate the coolant heater in the engine compartment.

Note : For H3 series vehicles, to have access to the heater, remove the lower panel in the rear electric compartment, for XLII series vehicles, open the rear service compartment.

2. Loosen the eye bolt nuts (item 2 figure 1) to release the eyebolts, and swing out the burner unit without stretching the fuel lines and electric cables.

Check all DBW 2010 Coolant Heaters that are in your stock or inboard to insure that Combustion Chambers are present (units manufactured beginning October 1999 through April 2000 only, see round sticker affixed on the burner). If a Combustion Chamber is missing from a heater, under no circumstances should the heater be used until the Combustion Chamber has been inserted.

INSTALLATION

1. Loosen the eye bolt nuts (item 2 figure 1) to release the eyebolts. (do not stretch the fuel lines and electric cables). Remove the cotter pin (item 4 figure 1) and remove the burner. Be careful not to hurt the ignition electrode.
2. Push the combustion chamber (item 1 figure 1) into the heat exchanger. If it is not possible to push it in all the way, use a plastic mallet and lightly tap all around the edge.
3. Close the burner unit, place the cotter pin and tighten the nuts on the eye bolts.
4. Turn on the switch and check function.

WARRANTY

This modification is covered by Prévost Car's normal warranty. We will reimburse a half hour (0.5) of labor for the installation of the burner upon receipt of a completed A.F.A. form on which you must specify as per "Safety Recall 00-25" plus the heater identification number and the fabrication number (serial number). **You also have to fill the "Safety Recall Certification Sheet" provided with this bulletin and return it with your A.F.A. form to be reimbursed.**



PREVOST

**Safety Recall
Certification Sheet
(Ref: Sr00-25)**

ENREGISTRÉ - REGISTERED
ISO 9001 & ISO 14001



SERIAL NUMBER: _____

PERFORMED BY		OWNER/OPERATOR	
We hereby certify that Safety Recall Instructions with regards to Safety Recall #00-25 have been performed.			
Name: _____		Name: _____	
Addr: _____		Addr: _____	
Phone: _____		Phone: _____	
Fax: _____		Fax: _____	
Signature :	_____	Signature :	_____
Date:	_____	Date:	_____

If the information mentioned above is incorrect or you are not the owner of this vehicle anymore, please fill this section and return to sender..

NEW OWNER: _____

BUSINESS: _____

ADDRESS: _____

TELEPHONE: _____ **FAX:** _____

**Please return this completed document with your
A.F.A. form**