

**PREVOST**

ENREGISTRÉ - REGISTERED  
**ISO 9001 & ISO 14001**

**WARRANTY  
 BULLETIN**

Wb02-12



<b>DATE :</b> January 2003	<b>SECTION :</b> 16 - Suspension
<b>EXPIRATION:</b> January 2004	
<b>SUBJECT :</b> NEW CAP FOR BELL CRANK AND IDLER ARM BALL JOINT	

**APPLICATION**

Model	VIN
VIP 45 Model Year : 2003	From 2PCV334933 <u>1014345</u> up to 2PCV334933 <u>1014443</u> incl.
H3-45 Coaches Model Year : 2003	2PCH3349X <u>31014436</u>
XL2 MTH W0, W5, Y5 Model Year : 2002	From 2PCW33494 <u>21027804</u> up to 2PCW33497 <u>21027862</u> incl.
XL2-45 Coaches Model Year : 2002	2PCX33492 <u>21027854</u>

**DESCRIPTION**

For the above-mentioned vehicles equipped with an independent suspension system (ISS), it is necessary to replace the ball joint cap on the idler arm and bell crank with a new more adjusted cap in order to ensure watertightness.

**MATERIAL**

Part No.	Description	Qty
161175	Cap, Ball Joint	2

**Note :** Material can be obtained through regular channels.

## PROCEDURE

**Warning :** Park vehicle safely, apply parking brake, stop engine and set battery master switch(es) to the OFF position prior to working on the vehicle. Prior to working under an air-suspended vehicle, it is strongly recommended to securely support the body at the recommended jacking points. Only the recommended jacking points must be used as outlined in Section 18 of Maintenance Manual: "Body" under heading "Vehicle jacking points" or in Operator's Manual.

1. Clean area around previous cap if required.
2. Remove previous caps and install new ones.

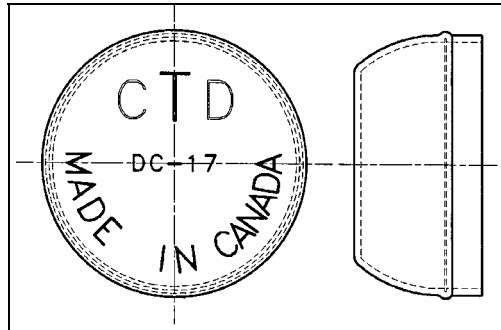

FIGURE 1: NEW CAP

3. Lubricate ball joint if required. Refer to section 18 in Maintenance manual for more information.

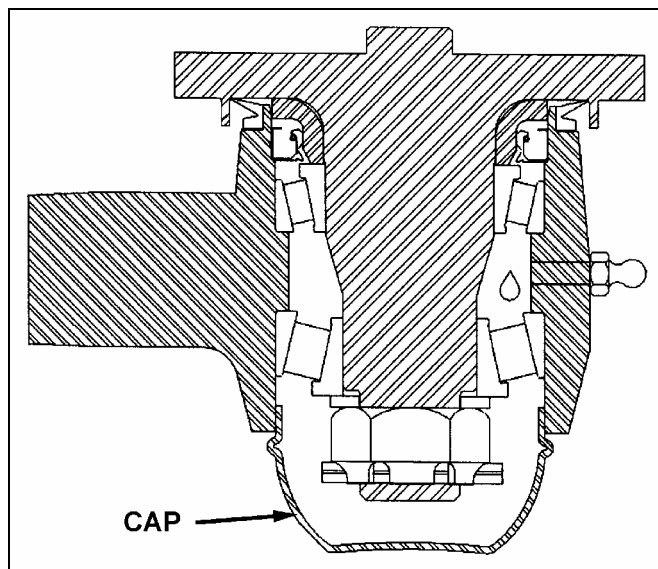

FIGURE 2: INSTALLATION OF NEW CAP

## WARRANTY

This modification is covered by Prévost Car's normal warranty. We will reimburse you the parts and half an hour (0.5) of labor upon receipt of a completed A.F.A. form on which you must specify as per "Warranty Bulletin 02-12".

### Parts / Waste disposal:

Discard waste according to applicable environmental regulations (Municipal/State[Prov.]/ Federal)