

PREVOST

**WARRANTY
BULLETIN**

WB13-48A

DATE :	AUGUST 2013	SECTION :	07 - Transmission
EXPIRATION:	AUGUST 2015		
SUBJECT :	RETARDER COOLER PIPING SUPPORT - WELD INSPECTION AND REPLACEMENT		

Revision A THIS BULLETIN SUPERSEDES PREVIOUS VERSIONS
September 18, 2013: Suspect range modification for H3-45 VIP

APPLICATION

NOTICE TO SERVICE CENTERS

*Verify vehicle eligibility by checking warranty bulletin status with **SAP** or **Vehicle Warranty Information** tool found on Prevost–Systems tab of the Volvo Trucks Dealer Portal*

Model	VIN
H3-45 Coach Model Year : 2013	Single vehicles 2PCH33494 <u>DC712269</u> and 2PCH3349X <u>DC712275</u>
H3-45 VIP Motorhome Model Year : 2013	From 2PCVS349X <u>DC712170</u> up to 2PCVS3499 <u>DC712452</u> incl.

This bulletin does not necessarily apply to all the above-mentioned vehicles, some vehicles may have been modified before delivery. The owners of the vehicles affected by this bulletin will be advised by a letter indicating the Vehicle Identification Number (VIN) of each vehicle concerned.

DESCRIPTION

On the vehicles affected by this bulletin a weld may be missing on a coolant piping support located on the retarder oil cooler support. In a first step, inspect the support for the presence of the weld. If there is no weld, perform the replacement of the piping support.

MATERIAL

If required, order the following parts:

Part No.	Description	Qty
071676	Oil cooler support	1

NOTE
Material can be obtained through regular channels.

PROCEDURE



DANGER

Park vehicle safely, apply parking brake, stop engine and set battery master switch(es) to the OFF position prior to working on the vehicle.

INSPECTION

1. Lift the vehicle and locate the oil cooler pipe support. It is located left of the transmission

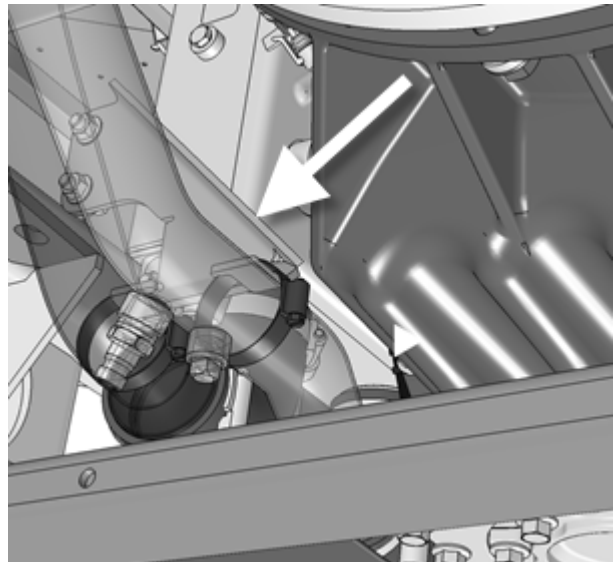
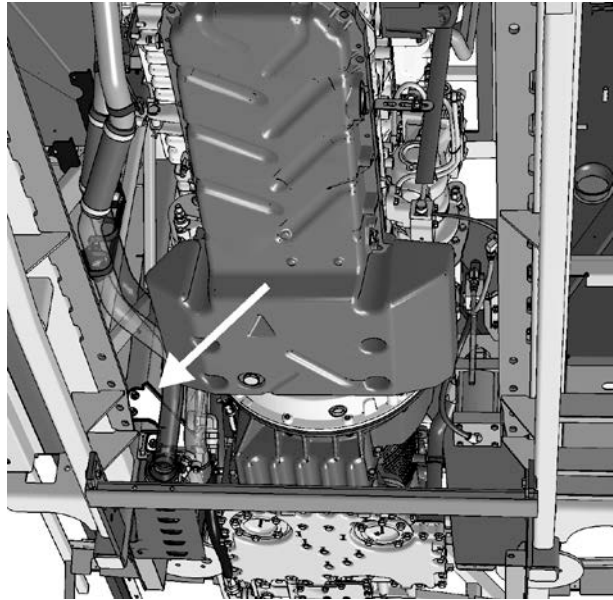

2. Using a telescopic inspection mirror, Make sure there is a weld fillet at this location on the piping support.

If there is a weld present, no further action is required.

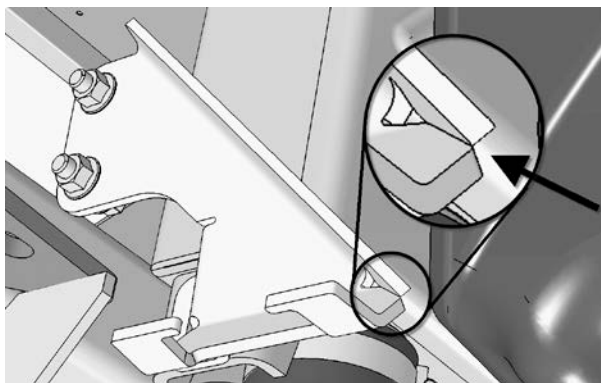

(Piping removed for clarity)

REMOVAL AND REPLACEMENT

If there is no weld, the part should be replaced.

1. Close the heating valves and make sure vehicle has cooled down for next steps.
2. Empty the coolant in an appropriate container.
3. Create some working space by removing the piping clamps, inlet and outlet piping and elbows. Collect any coolant left at this point.

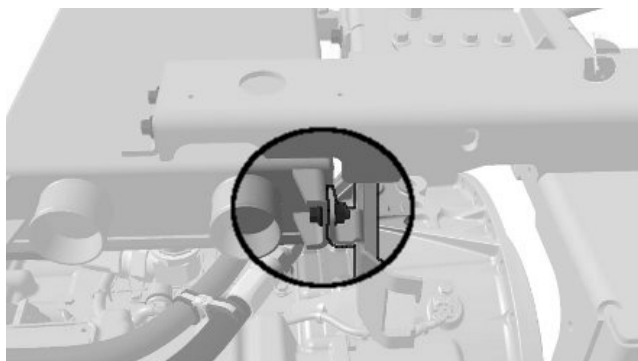

View from bottom

This should give you access to the support bolts.

Refer to images for mounting bolt locations

4. Remove and discard the piping support and replace with the new part.
Tighten to 32 lbf-ft (44 N-m)
5. Re-install the piping and elbows.
6. Fill the coolant system.
7. Re-open heating valves.
8. Check cooling system for leaks and vehicle for proper operation.

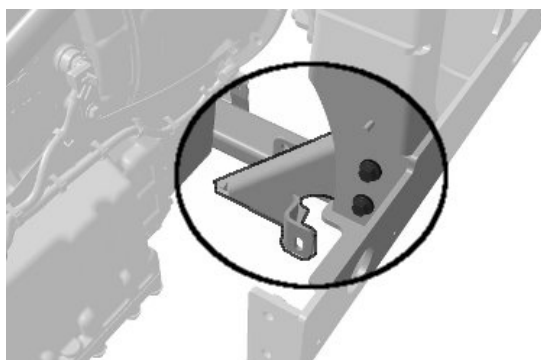

Reverse angle.

PARTS / WASTE DISPOSAL

Return replaced parts to Prevost with A.F.A. for full reimbursement.

WARRANTY

This modification is covered by Prevost's normal warranty. We will reimburse you fifteen minutes (15min) of labor **for inspection only**, parts or one hour (1h) of labor **for inspection and replacement** upon receipt of the replaced parts and a completed A.F.A. form on which you must specify as per "Warranty Bulletin WB13-48A".

OTHER

VBC Bulletin	N/A
Fail Code	07.04
Defect Code	09
System Condition	B
Causal Part	071676

Access all our Service Bulletins on
<http://prevostparts.volvo.com/technicalpublicatios/en/pub.asp>
Or scan the QR-Code with your smart phone.

E-mail us at technicalpublications_prev@volvo.com and type
"ADD" in the subject to receive our warranty bulletins by e-mail.

