

**PREVOST**

**WARRANTY  
BULLETIN**

Wb98-04



<b>DATE :</b> March 1998	<b>SECTION :</b> 06
<b>SUBJECT :</b> REPLACEMENT OF REAR START SWITCH BOX	

**APPLICATION**

Model	VIN
All H3 Series Vehicles Model Year: 1990 - 1996	 From 2P9V33402L1001030 up to 2PCH33493T1011474 incl.

**DESCRIPTION :**

On the above-mentioned vehicles, rear start switch box is replaced with a watertight assembly.

**MATERIAL**

Part No.	Description	Qty
381804	Box assembly, rear start switch	1
562566	Connector	1
561608	Pin, contact	5

**Note:** Material can be obtained through regular channels.

**PROCEDURE**

**Warning:** Park vehicle safely, apply parking brake, stop engine and set battery master switch(es) to the OFF position prior to working on the vehicle.

1. Open engine compartment door (refer to fig. 1).
2. Cut wires as close as possible to rear start switch input connector (refer to fig. 2).
3. Unfasten rear start switch box attaching parts and remove the box, keep attaching parts aside.
4. Secure new rear start switch box (Prévost #381804) using attaching parts.
5. Remove about 3/8 inch of sheath covering each wire and crimp a contact pin (Prévost #561608) onto each wire.

**Note :** It is recommended to use crimping tool (Prévost #682247) to crimp contact pins.

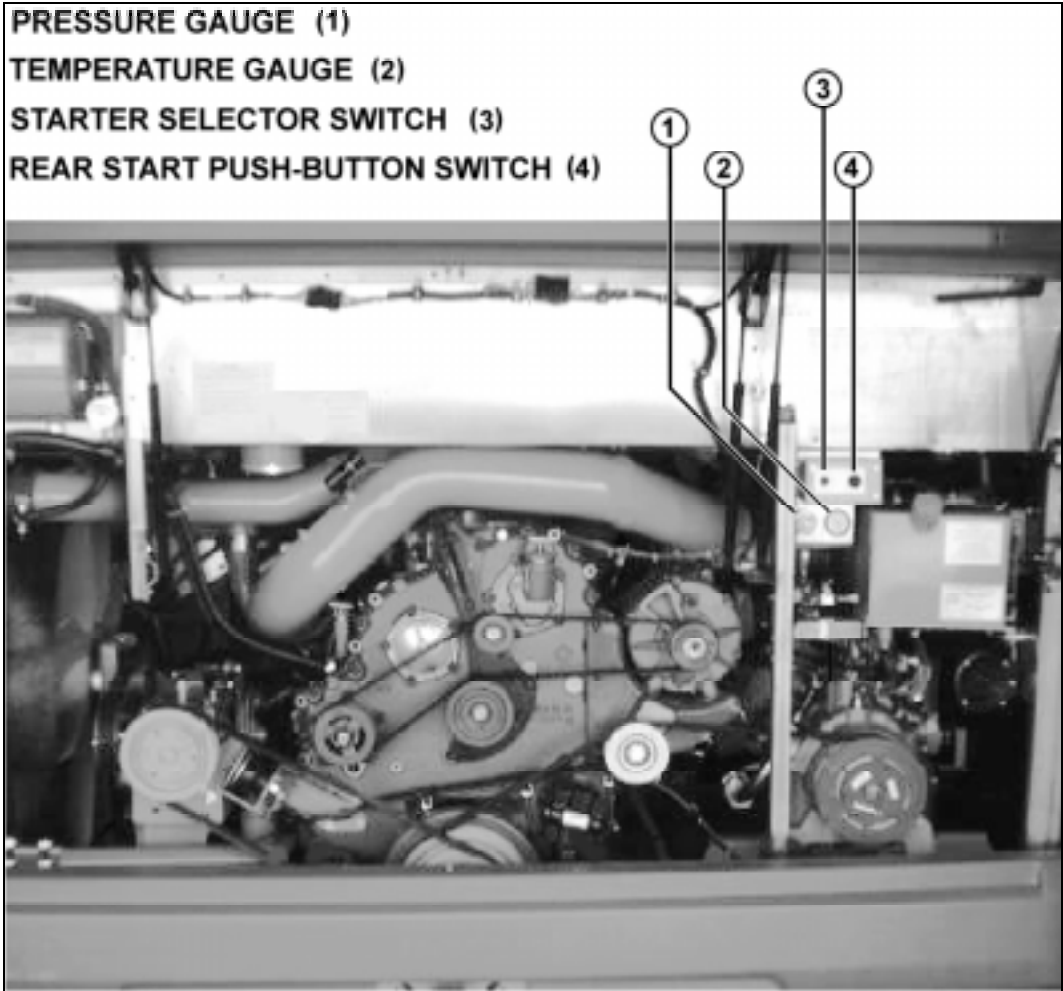

FIGURE 1 : ENGINE COMPARTMENT

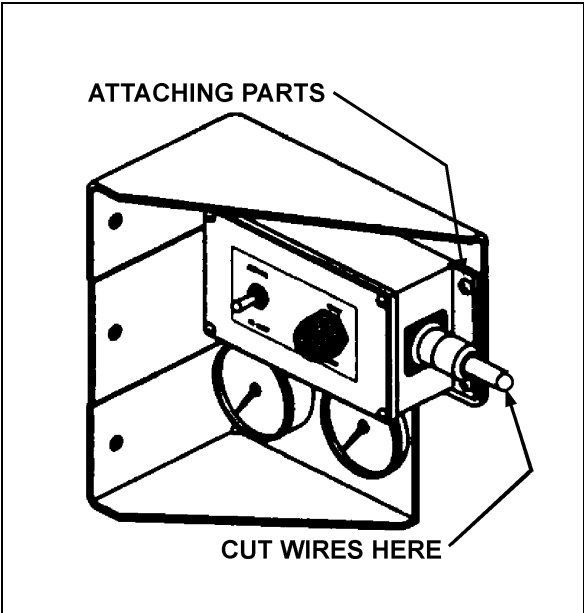

FIGURE 2 : REAR START SWITCH BOX

- Carefully insert contact pins into connector housings (Prévoist #562566) as per figure 3 and join connector with rear start switch box input connector.

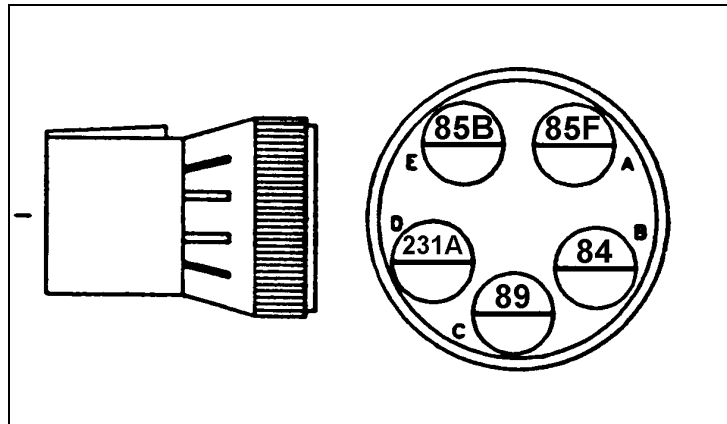

FIGURE 3 : CONNECTOR

## WARRANTY

This modification is covered by the manufacturer's normal warranty. We will reimburse you the parts and one hour (1.0) of labor upon receipt of a completed A.F.A. form on which you must specify as per "Warranty Bulletin 98-04".

### Parts disposition:

- Discard according to applicable environmental regulations (Municipal/State[Prov.]/ Federal)

Expiration date : March 1999