

MATERIAL

X3-45 coaches, XLII Entertainer, X3-45 VIP: order kit "WB14-28" which includes the following parts:

Part No.	Description	Qty
069020	HARNESS, INTERFACE	1
069041	LTD (Linear Thermal Detector)	1
406701	SUPPORT, IR SENSOR	1
563457	SENSOR, INFRARED	1
500321	WASHER, BEL SPR .331x.827x.098 ZG603	1
502851	NUT, HEX M8-1.25 ZG603	1
5001742	SCREW, CAP HEXF M8-1.25x30 G8.8 ZG603	1
561565	SEAL 20-18 g	2
561578	TERMINAL, SOCKET 16-14 g	1
561689	TERMINAL, SOCKET 20-18 g	2
561782	CONNECTOR, SOCKET HOUSING PED WEATHER PACK	1
561786	SEAL 16-14 g	1
563588	TERMINAL, PIN	2
563589	CONNECTOR, SOCKET HOUSING DTM 06-2S	1
563590	CONNECTOR, PIN HOUSING DTM 04-2P PH 2C	1
563604	LOCK, SECONDARY	1
563606	PLUG, SEALING	2
5001017	SCREW, THREAD CUTTING HEX #10-24x1/2	6
564534	EDGE CLIP, CABLE TIE	1
500964	WASHER, FLAT .203 x .500 x .047 ZP	6
504013	TIE MOUNT, 1/4 x 1/4	6
507664	CABLE TIE, NYLON 3/16" x 11" DOUBLE LOOP HEAD	18
504637	CABLE TIE, NYLON 3/16" x 13"	20
502841	NUT, HEX NYRT M5-0.8 ZG603	2
5001146	SCREW, CAP HEX M5-0.8x20 SS EMN	2

H3 series coaches: order kit "WB14-28-2" which includes the following parts:

Part No.	Description	Qty
069020	HARNESS, INTERFACE	1
069041	LTD (Linear Thermal Detector)	1
217797	SUPPORT, IR SENSOR	1
504379	RIVET POP, DOME SS 3/16" x 1/4"	3
563457	SENSOR, INFRARED	1
502570	WASHER, SPLIT LOCK 6.1 x 11.8 x 1.6	2
5001146	SCREW, CAP HEX M5-0.8x20 SS EMN	2
561565	SEAL 20-18 g	2
561578	TERMINAL, SOCKET 16-14 g	1
561689	TERMINAL, SOCKET 20-18 g	2
561782	CONNECTOR, SOCKET HOUSING PED WEATHER PACK	1
561786	SEAL 16-14 g	1
563588	TERMINAL, PIN	2
563589	CONNECTOR, SOCKET HOUSING DTM 06-2S	1
563590	CONNECTOR, PIN HOUSING DTM 04-2P PH 2C	1
563604	LOCK, SECONDARY	1
563606	PLUG, SEALING	2
507664	CABLE TIE, NYLON 3/16" x 11" DOUBLE LOOP HEAD	18
504637	CABLE TIE, NYLON 3/16" x 13"	20

<i>NOTE</i>
<i>Material can be obtained through regular channels.</i>

 <b style="font-size: 1.2em;">DANGER
<p>Park vehicle safely, apply parking brake, stop engine and set battery master switch(es) to the OFF position prior to working on the vehicle.</p>

PROCEDURE

PART 1 - LTD INSTALLATION GUIDELINES	5
PART 2 – PREPARATION	7
PART 3 – REMOVAL OF EXISTING IR SENSOR AND SUPPORT	10
PART 4 – INSTALLATION OF NEW IR SENSOR (XLII & X3 SERIES).....	11
PART 5 – INSTALLATION OF NEW IR SENSOR (H3 SERIES).....	12
PART 6 – REMOVAL OF EXISTING LTD (Linear Thermal Detector).....	13
PART 7 – HOOKING UP ON EXISTING HARNESS	15
PART 8 – INSTALLATION OF NEW LTD	16
PART 9 – ROUTING INTERFACE HARNESS UP TO THE IR SENSOR (XLII & X3 SERIES).....	19
PART 10 – ROUTING INTERFACE HARNESS UP TO THE IR SENSOR (H3 SERIES).....	23

PART 1 - LTD INSTALLATION GUIDELINES

IMPORTANT: WHEN INSTALLING THE "LTD", THE FOLLOWING GUIDELINES MUST BE FOLLOWED.

NOTE
Always use double loop cable ties to secure LTD. LTD must be tied alone, with no other cables in the loop.

NOT ALLOWED

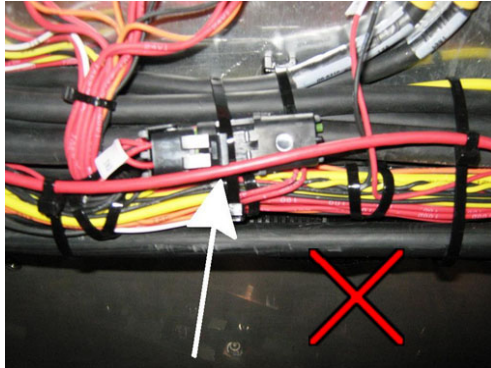

Possible contact or rubbing against screws, edges, etc.

CORRECT

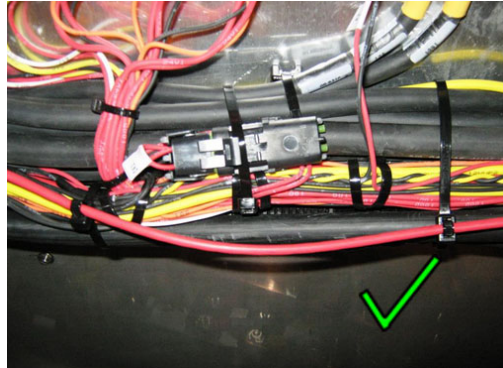

LTD must be routed clear of screws, sharp edges, etc.

NOT ALLOWED

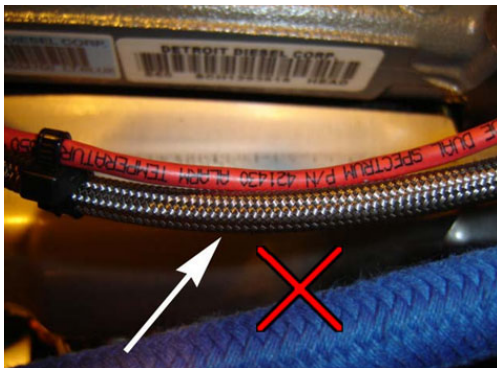

Rubbing or possible rubbing against abrasive surfaces

CORRECT

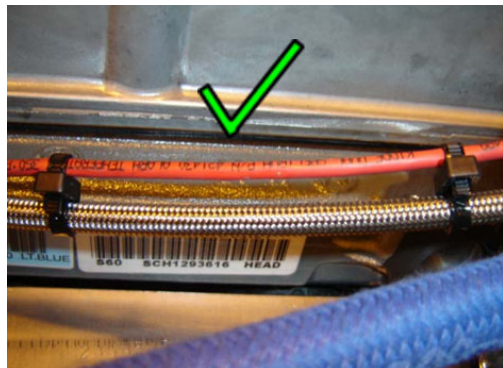

LTD must be secured with double loop cable ties. Distance between cable ties must not exceed 4 inches (100mm) max

NOT ALLOWED

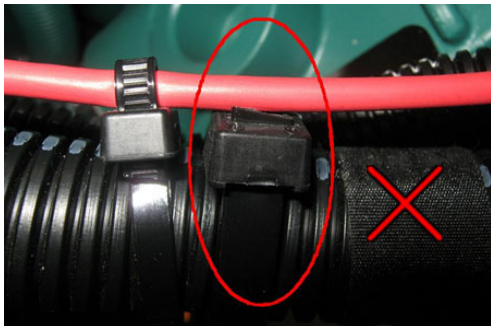

LTD touching cut cable tie

NOT ALLOWED

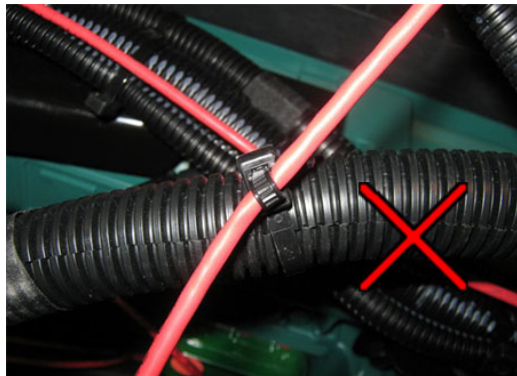

LTD extending slantingly from the cable tie

CORRECT

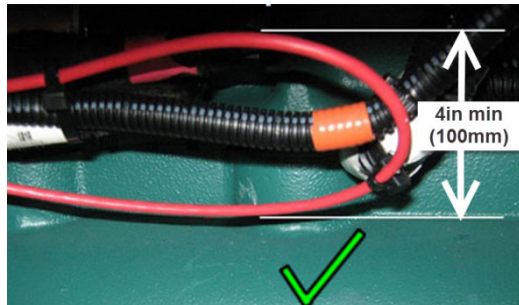

LTD is not a flexible harness. Avoid tight bends and kinks which could short circuit the LTD. Loops must have a minimum radii of 4 inches (100 mm)

NOT ALLOWED



Cable tie tighten in excess on the LTD. Tighten cable tie on LTD by hand only. Tighten just enough to prevent LTD from slipping from once side to the other inside the cable tie loop

CORRECT

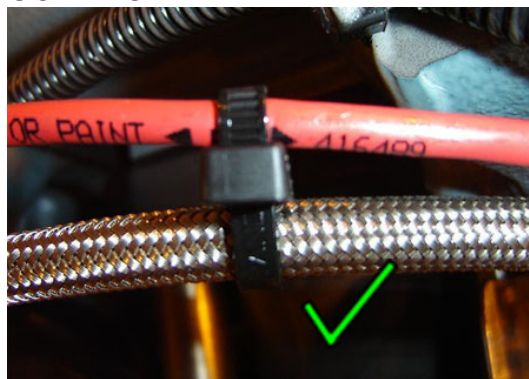

Proper tightening of the cable tie on the LTD

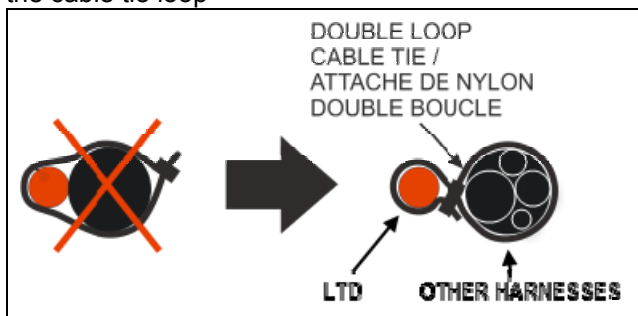

PART 2 – PREPARATION

- 1) With the battery master switch to the ON position and the ignition switch to the ON position, check that there are no trouble conditions on the AFSS system. Check that the driver's area AFSS protection panel SYSTEM OK green lamp is illuminating. If it is not illuminating, then the TROUBLE lamp should blink or illuminate steady. You must troubleshoot and correct that situation prior proceeding to this bulletin.
- 2) Disconnect the extinguisher bottle connector. If available, plug special device Kidde Valve Simulator (Prevost #685128).

The Valve Simulator is used to simulate the squib and discharging of an extinguisher. It plugs into the wiring harness of the extinguishing circuit and provides an audible warning (chirp) when a signal is received from the control panel to discharge the extinguisher.

Failure to do so may result in extinguisher discharge at time of resetting the system if the LTD is short circuited due to improper manipulations and/or faulty installation.



FIGURE 1

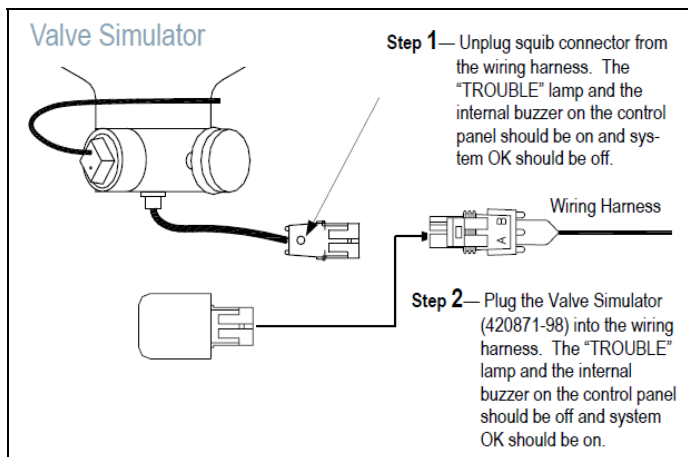

FIGURE 2

- 3) Turn the ignition switch to the OFF position. Set the battery master switch to the OFF position.
- 4) Inside the front electrical compartment, pull fuse F45 to cut electrical supply to the AFSS protection panel (see FIGURE 3).

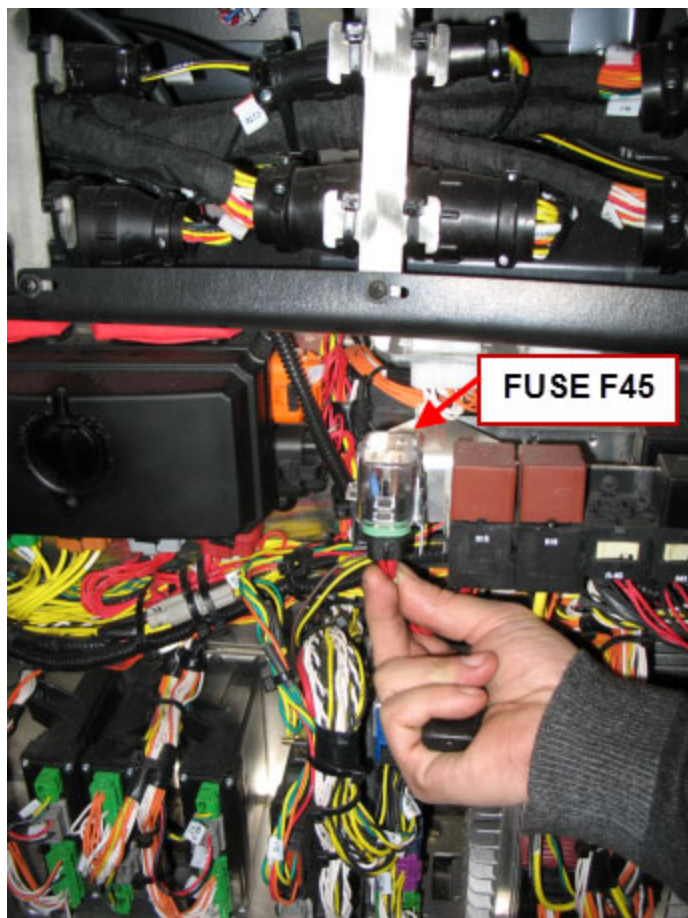

FIGURE 3: FUSE F45 INSIDE FRONT ELECTRICAL COMPARTMENT

- 5) **H3 SERIES:** To ease access to the engine, remove the rectangular access hatch located at the rear end of the passenger's area central aisle.
- 6) **X3 SERIES:** To ease access to the engine, remove the rectangular access hatch (figure 4) located under the rear seats shown on FIGURE 5. To do so, remove the seats, unscrew one nut each side of the seat cushions (FIGURE 6) and remove the seat cushions (use 10mm socket). Then, unscrews the four seat frame mounting bolts, use 17mm socket (FIGURE 7).



FIGURE 4

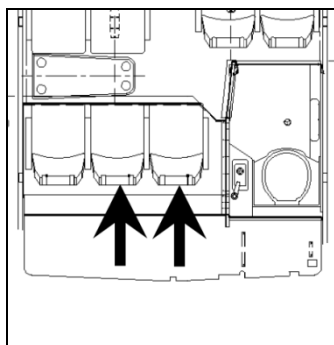

FIGURE 5

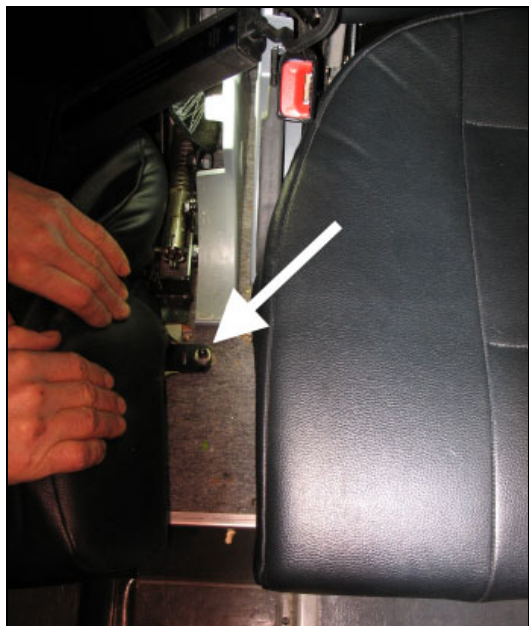

FIGURE 6 (X3 SERIES ONLY)



FIGURE 7 (X3 SERIES ONLY)



FIGURE 8 (X3 SERIES SHOWN)

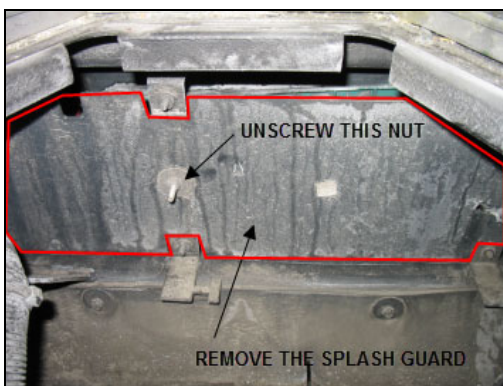

FIGURE 9: REMOVE SPLASH GUARD SHOWN

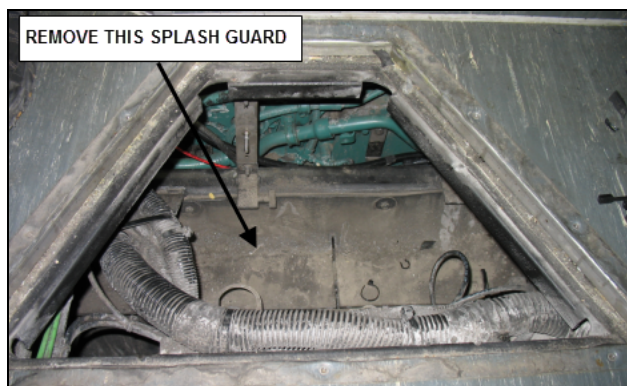

FIGURE 10: REMOVE SPLASH GUARD SHOWN

- 7) **X3 SERIES:** Remove the trapezoidal access hatch located at the rear of the passengers' area (FIGURE 8).
- 8) If applicable, remove the splash guard (see FIGURE 9, may differ on H3 series). To do so, unscrew one nut (use 10mm socket).
- 9) If applicable, remove the other splash guard (FIGURE 10, may differ on H3 series). To do so, remove 4 screws (use 10mm socket).

PART 3 – REMOVAL OF EXISTING IR SENSOR AND SUPPORT

- 1) Locate the IR sensor and support above the turbo (FIGURE 11).
- 2) Disconnect A131A & A131B at the IR sensor (A, FIGURE 12).
- 3) Cut the nylon cable ties along the support and cut the nylon cable ties securing the engine compartment light cable up to the light (B, FIGURE 12).

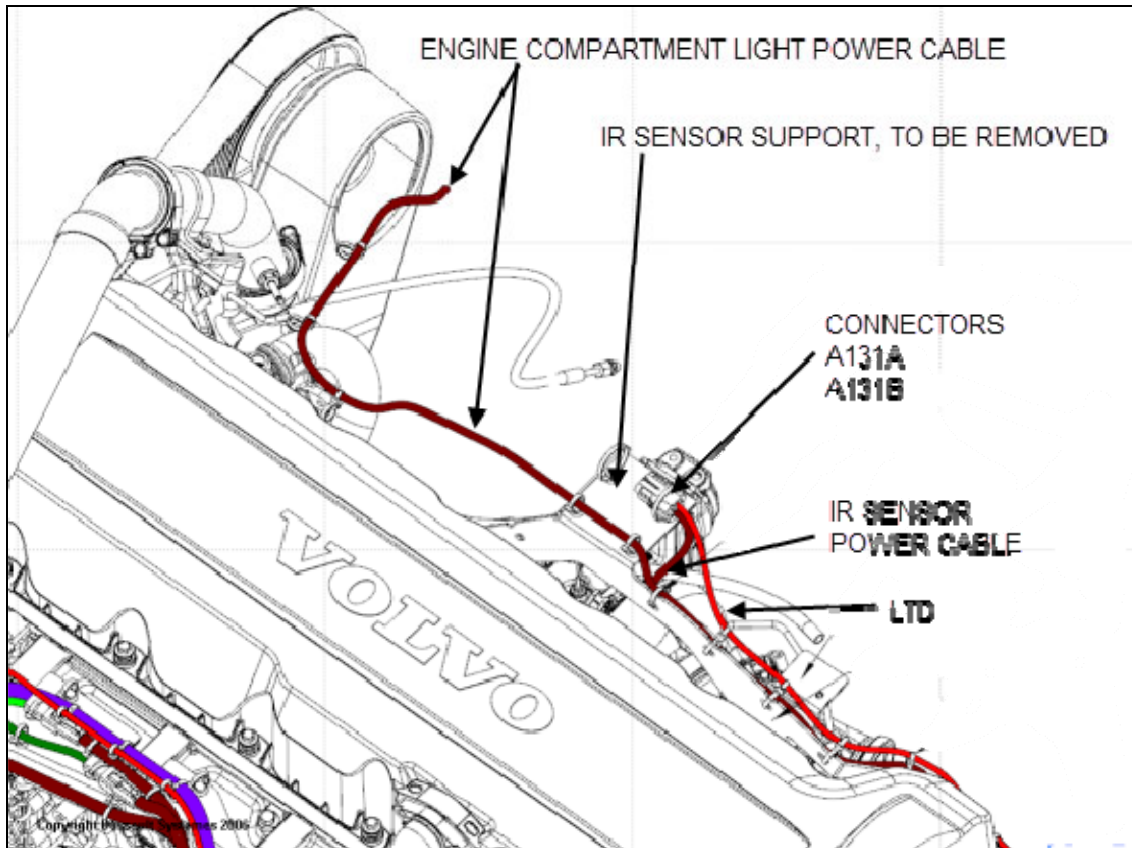

FIGURE 11: IDENTIFICATION OF COMPONENTS AND HARNESSES

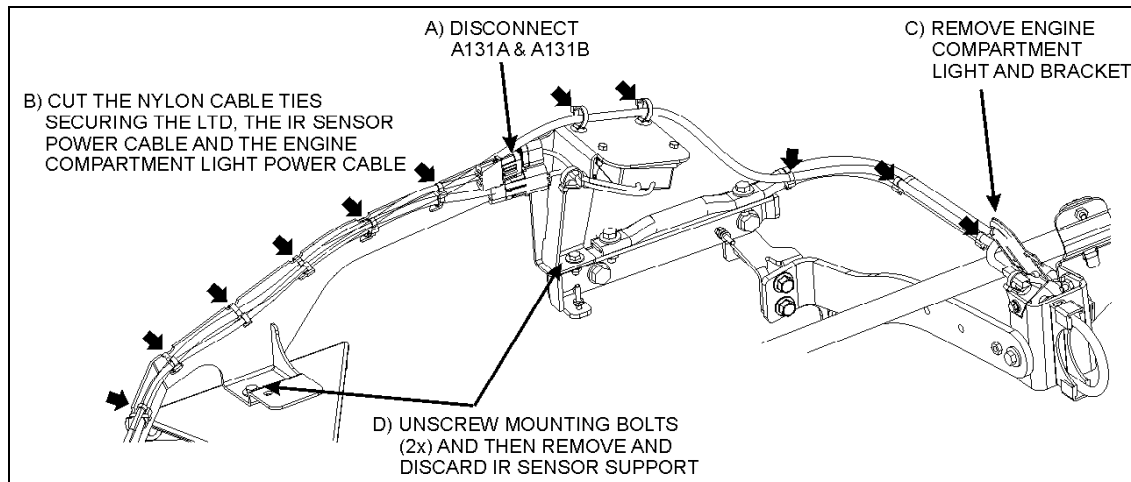

FIGURE 12

- 4) Remove and discard the engine compartment light and bracket (C, FIGURE 12).
- 5) Remove and discard the IR sensor support (D, FIGURE 12).



CAUTION

Do not reuse the old IR sensor as it may fail prematurely and offer no protection.

PART 4 – INSTALLATION OF NEW IR SENSOR (XLII & X3 SERIES)

- 1) Unscrew the bolt at the turbo inlet pipe support bracket (FIGURE 13).
- 2) Mount the new IR sensor onto the new support #406701 (FIGURE 14). Install IR sensor and support assembly onto turbo inlet pipe support bracket as per FIGURE 13. Take note that the sensor cables must be placed on the exterior side of the engine compartment.

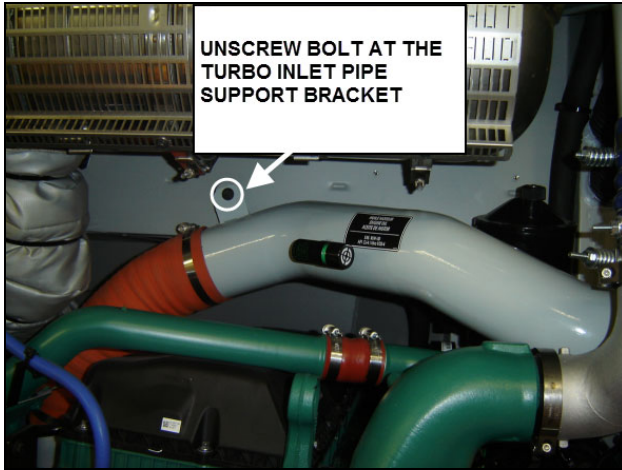

FIGURE 13

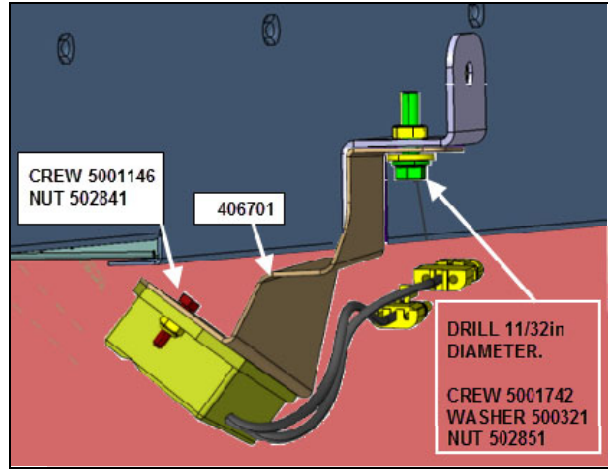

FIGURE 14

PART 5 – INSTALLATION OF NEW IR SENSOR (H3 SERIES)

- 1) Install the new IR sensor at new location as shown on FIGURE 15. The IR sensor will be installed on the stainless steel panel on top of the engine.

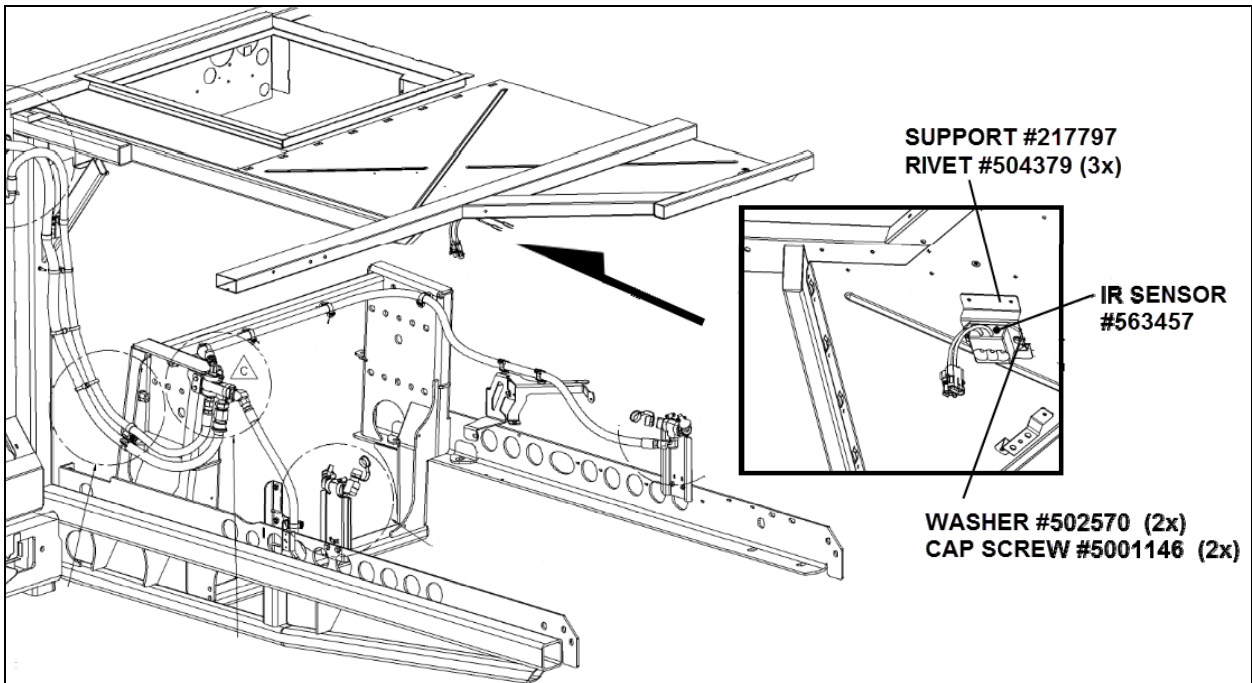

FIGURE 15

- 2) First, install support #217797 as shown on FIGURE 16. Locate the support according to measurements of FIGURE 17.

- 3) Pre-drill three 7/32" holes for the installation of the support. Secure support using three pop rivets #504379.

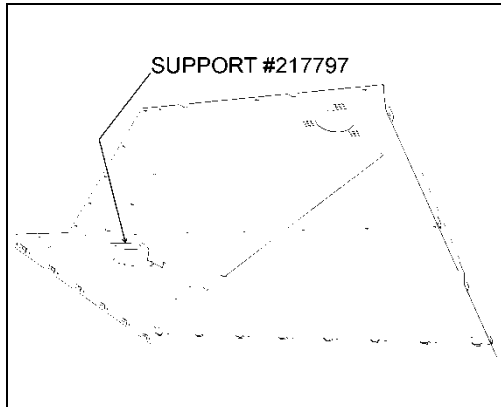

FIGURE 16

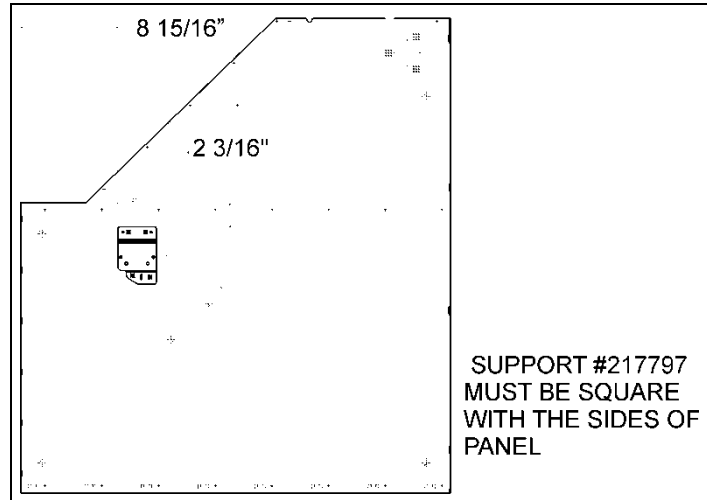

FIGURE 17

- 4) Fix IR sensor onto support as shown on FIGURE 18, using two split lock washers #502570 and two cap screws #5001146. IR sensor must be oriented so that the cables exiting the sensor body are located aft of the engine compartment.

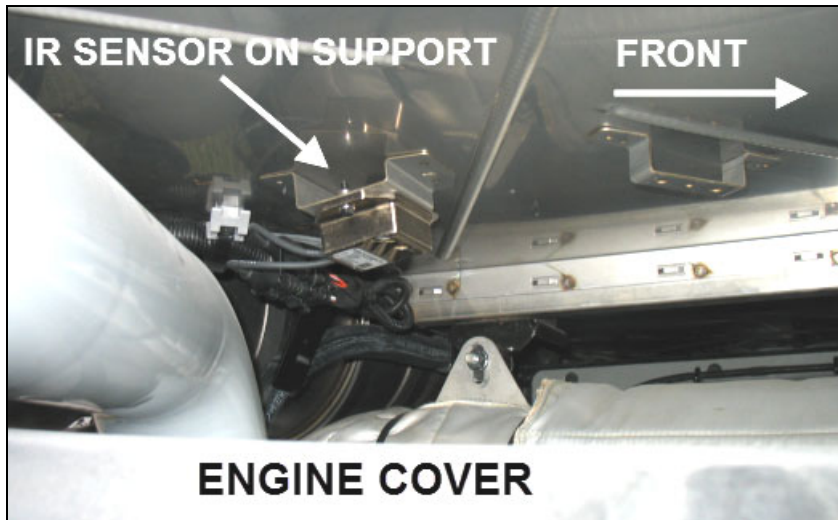

FIGURE 18

PART 6 – REMOVAL OF EXISTING LTD (Linear Thermal Detector)

- 1) Cut all nylon cable ties and remove the entire LTD (cable with red sheath). On the engine hot side, the LTD may be routed under the starter and forms a loop and then comes back and runs to the cold side of the engine (FIGURE 19). On the cold side, the LTD is routed as shown on FIGURE 20. Keep the termination (a.k.a. EOL End of Line device) connector found at the end of the LTD for reused.

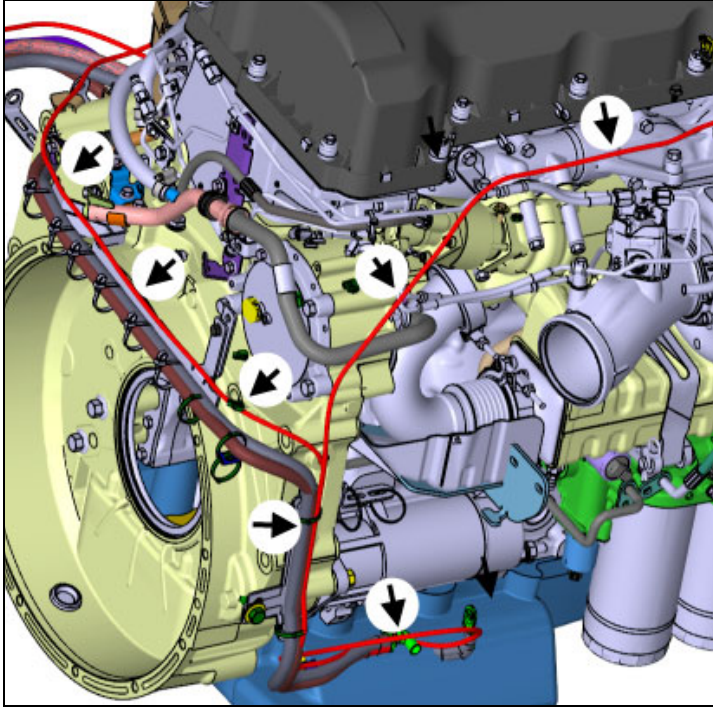

FIGURE 19: REMOVE LTD

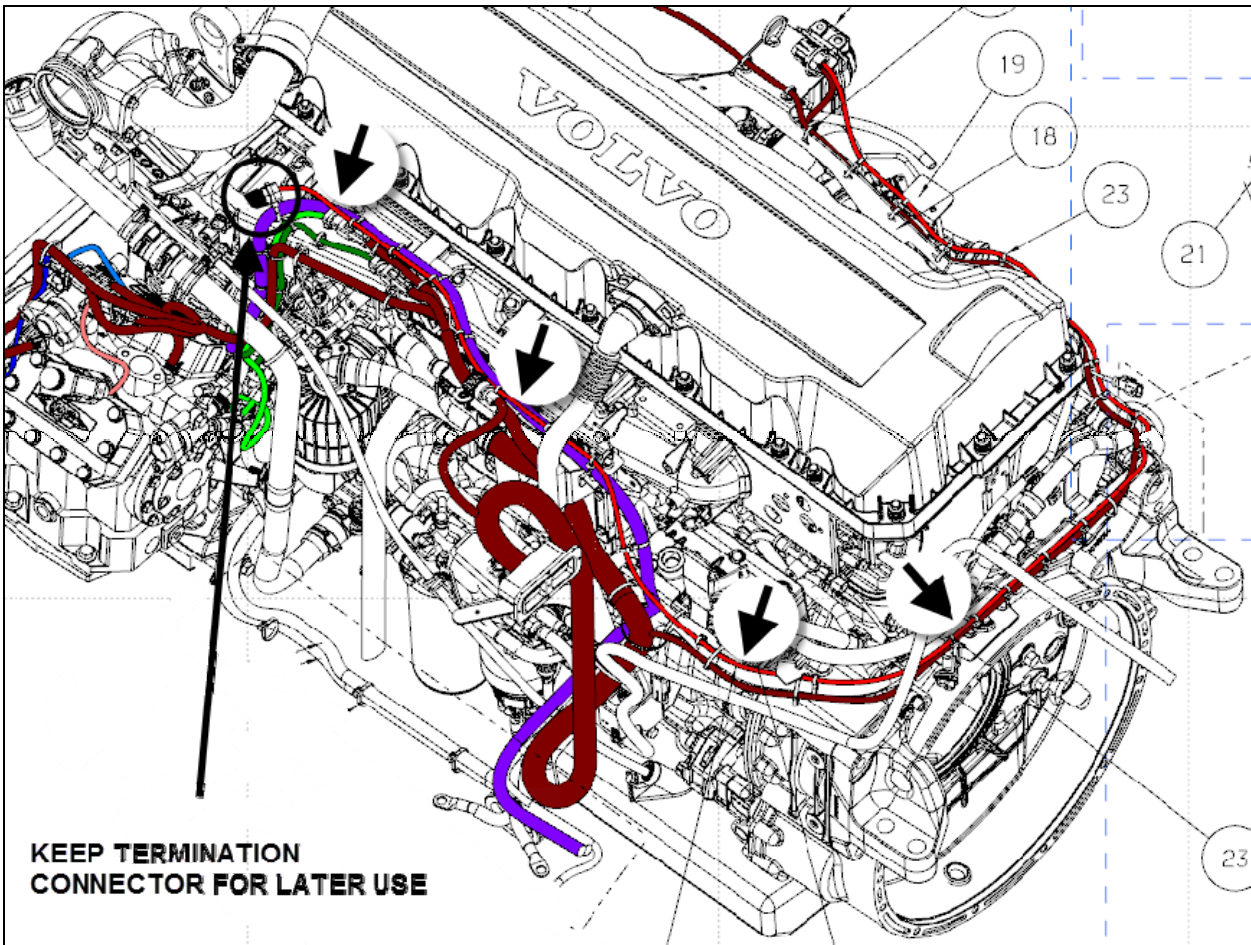

FIGURE 20: REMOVE LTD. KEEP TERMINATION CONNECTOR (A.K.A. EOL)

PART 7 – HOOKING UP ON EXISTING HARNESS

- 1) The engine compartment light power cable and the IR sensor power cable are joined together in one single harness. Locate this harness and cut it close to the bracket shown on FIGURE 21. Discard the section of this harness that runs on the turbo side.

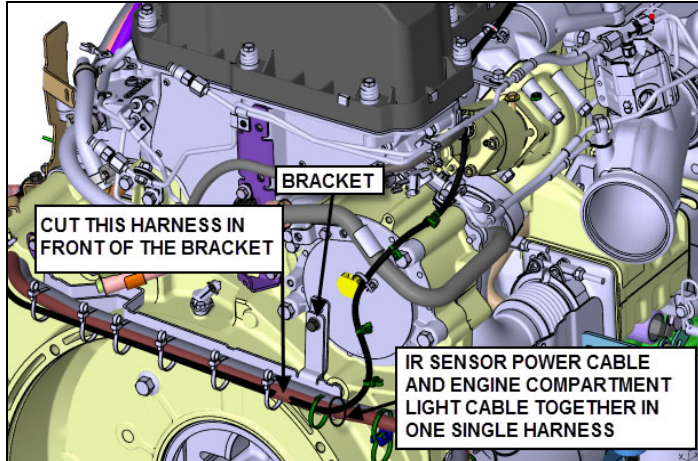

FIGURE 21: CUT THE HARNESS CLOSE TO THE BRACKET

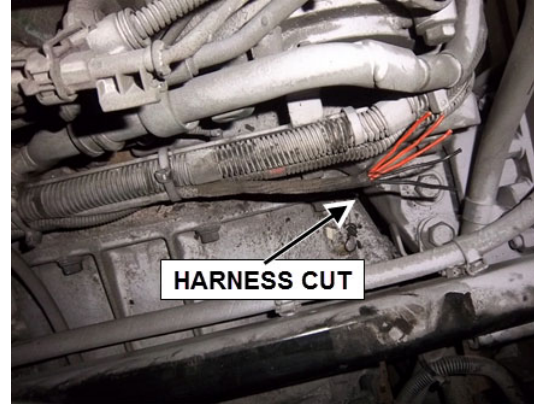

FIGURE 22: EXISTING HARNESS

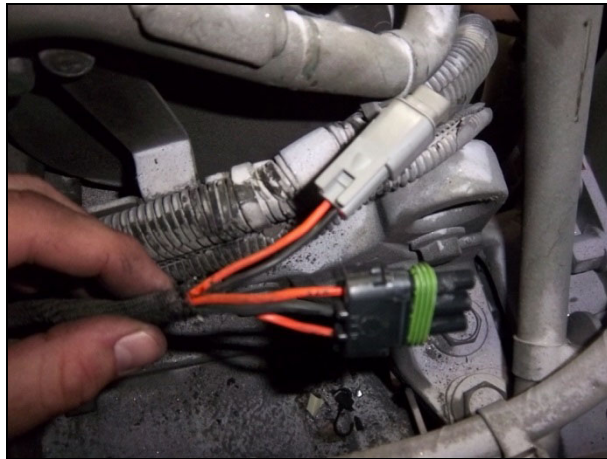

FIGURE 23

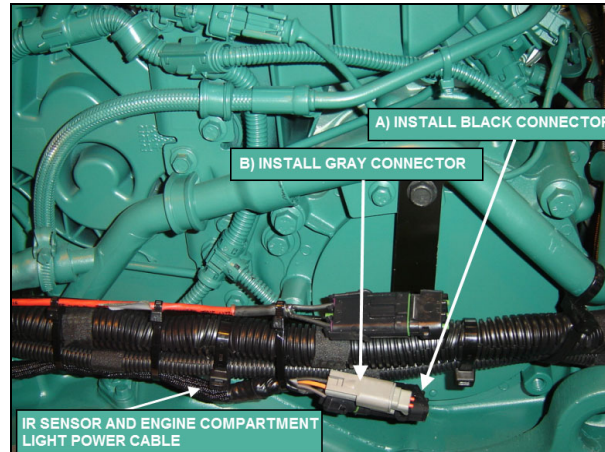

FIGURE 24

- 2) **Installation of black connector** (FIGURE 23, FIGURE 24). Inside the remaining section of previous step harness, identify and separate circuits 346, 0FE (ground) and 347. Install a PED Weather Pack connector.

Use:

1x TERMINAL, SOCKET 16-14 g #561578 (for ground wire 0FE)
 2x TERMINAL, SOCKET 20-18 g #561689
 1x CONNECTOR, SOCKET HOUSING #561782
 1x SEAL 16-14 g #561786 (for ground wire 0FE)
 2x SEAL 20-18 g #561565

circuit	cavity
346	A
0FE	B
347	C

- 3) **Installation of gray connector** (FIGURE 23, FIGURE 24, FIGURE 25). Inside the remaining section of the harness (previous steps), identify separate circuits 9B and 0RA2. Install a Deutsch DTM connector. This connector is installed as provision for further use if needed.

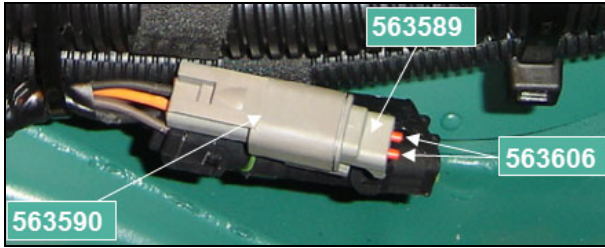

FIGURE 25: DEUTSCH CONNECTOR

Use:

- 2x #563588 TERMINAL, PIN
- 1X #563589 CONNECTOR, SOCKET HOUSING DTM 06-2S
- 1X #563590 CONNECTOR, PIN HOUSING DTM 04-2P PH 2C
- 1X #563604 LOCK, SECONDARY
- 2X #563606 PLUG, SEALING

circuit	cavity
9B	2
0RA2	1

PART 8 – INSTALLATION OF NEW LTD

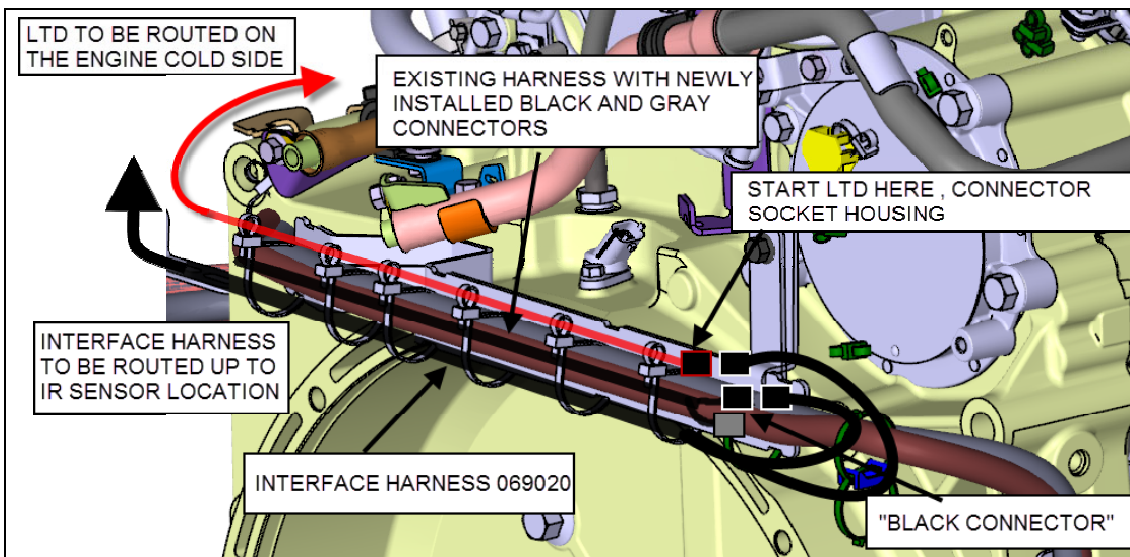

Figure 26

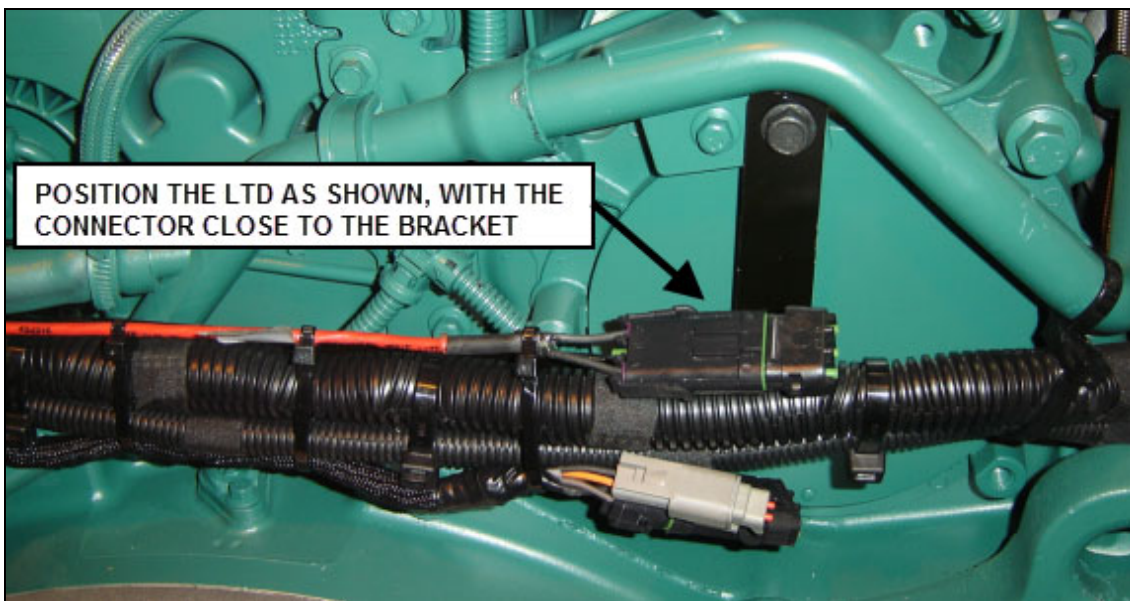

Figure 27

- 1) Secure LTD to existing nearby harnesses (see Figure 26 for proper installation) using 6 double loop head nylon cable ties 507664. Use the second loop to attach the LTD (Figure 26 and Figure 27). Tighten the loop fixing the LTD by hand only. Follow the general recommendations.
- 2) Connect the interface harness #069020 to black and newly installed LTD as shown on Figure 28 , Figure 29 & FIGURE 30.

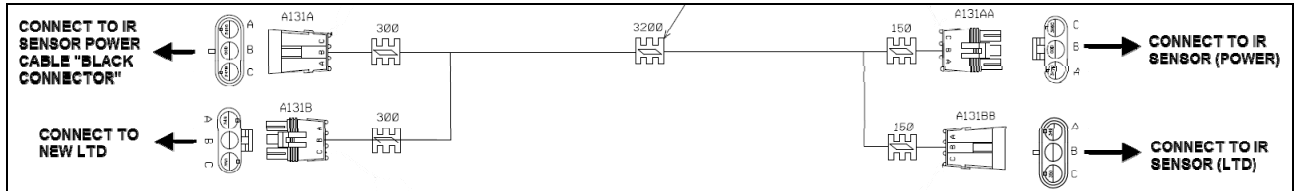

Figure 28: INTERFACE HARNESS #069020

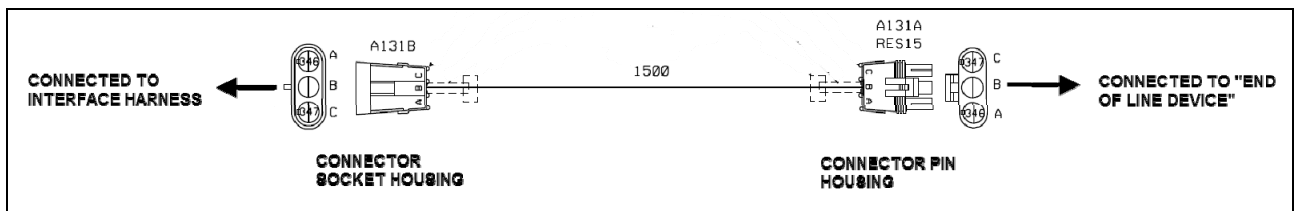

Figure 29: NEW LTD #069041

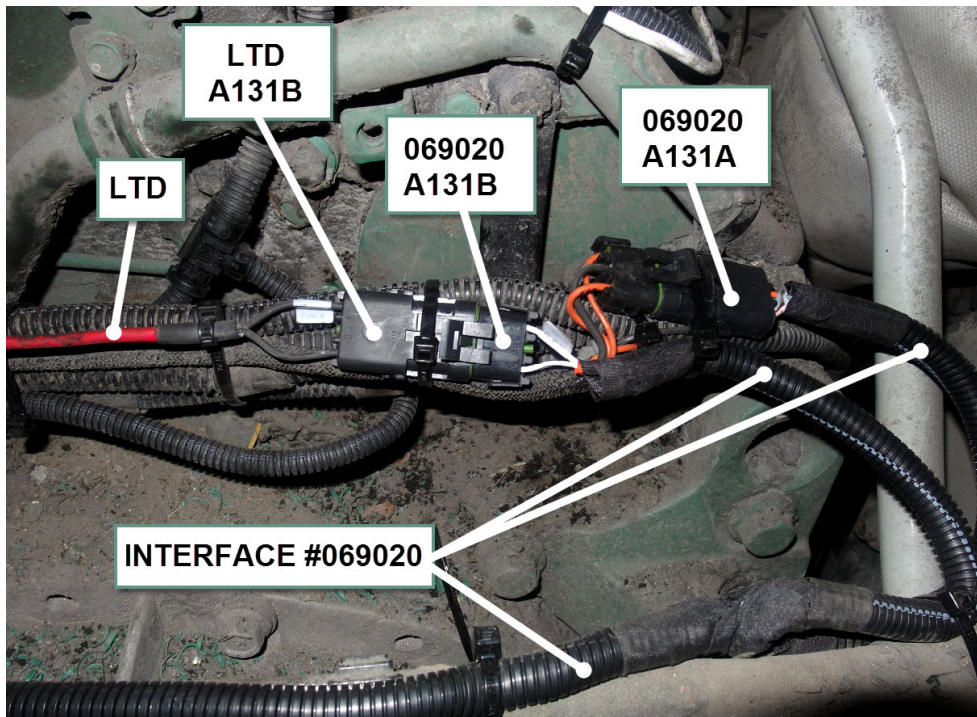
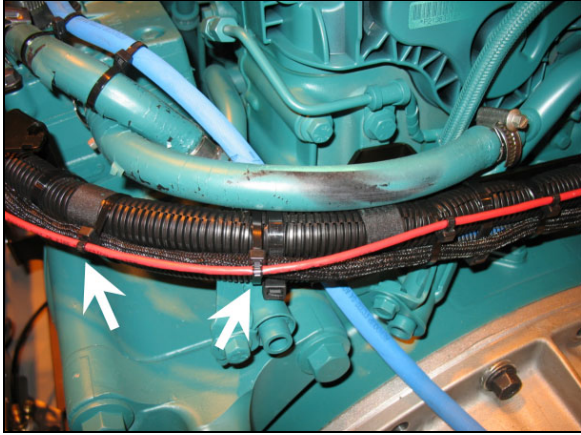

FIGURE 30 : CONNECTIONS COMPLETED – TAKE NOTE THAT THE GREY CONNECTOR IS NOT VISIBLE ON THIS PICTURE

- 3) Route the LTD using double loop nylon cable ties. For each attachment point of the LTD, fix one loop of the cable tie around the close harnesses corrugated sleeve. Use the second loop to attach the LTD. Tighten the loop fixing the LTD by hand only. Follow the general recommendations.
- 4) Refer to the following pictures for proper attachment point location and installation method (consult the PDF color version of this document).



STEP 3 A



STEP 3 B

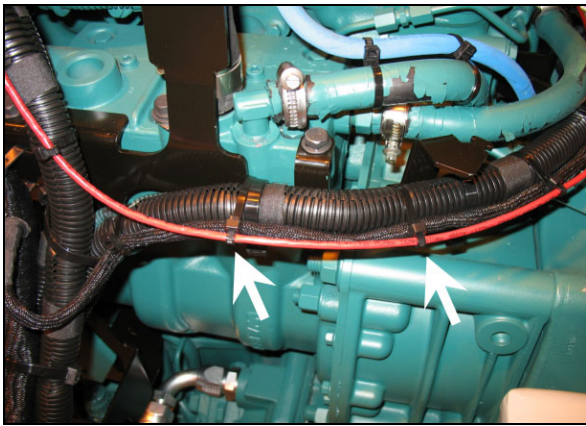

STEP 3 C

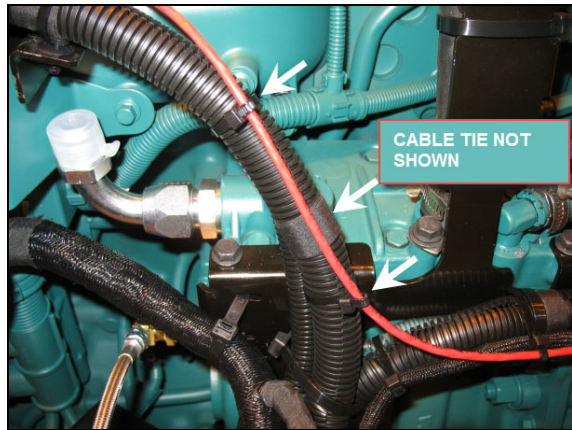

STEP 3 D

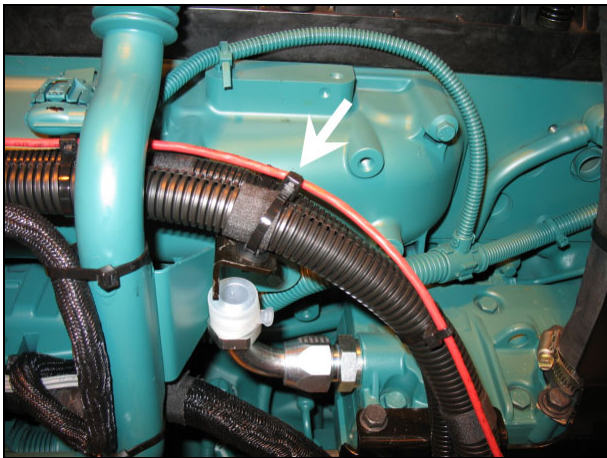

STEP 3 E

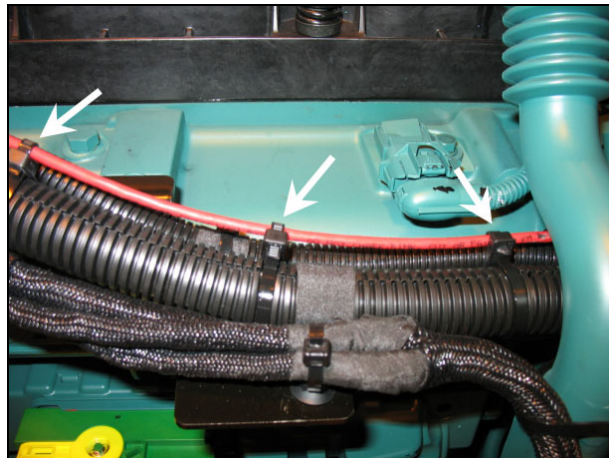

STEP 3 F



STEP 3 G



STEP 3 H: TERMINATION CONNECTOR

PART 9 – ROUTING INTERFACE HARNESS UP TO THE IR SENSOR (XLII & X3 SERIES)

- 1) Route the interface harness up to the IR sensor new location. Unlike the LTD, the interface harness is route on the vehicle structure, curbside. See images below.

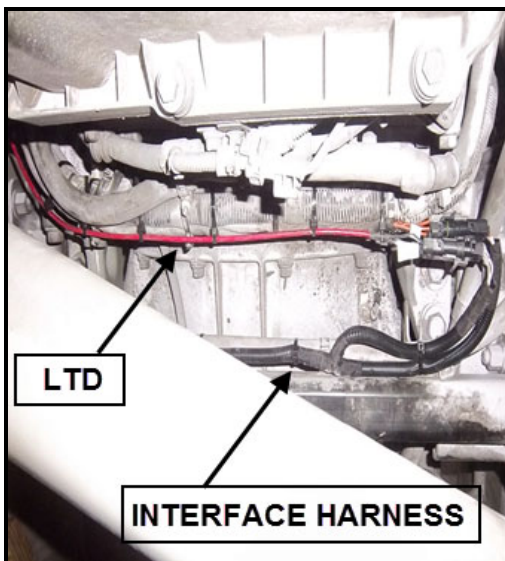

STEP 1-A

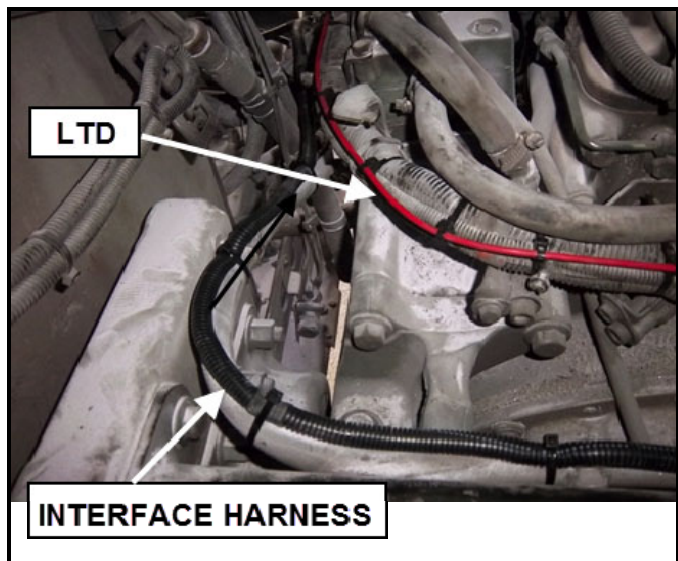

STEP 1-B

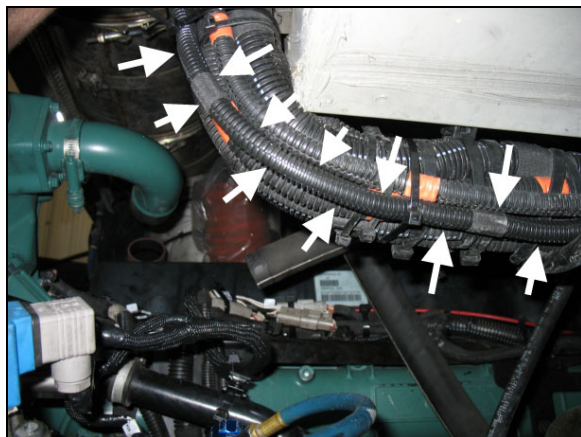
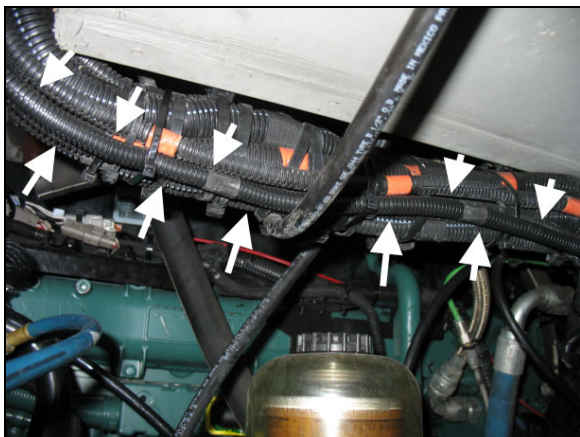
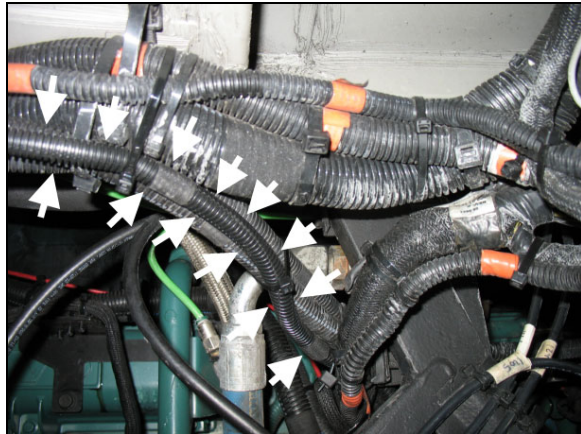
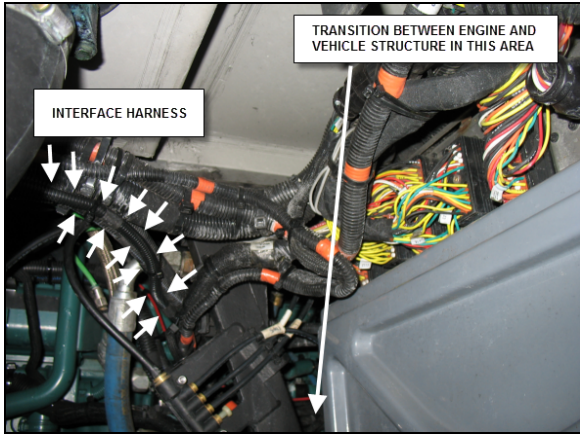



STEP 1-G

- 2) At this point, the end of the interface harness should be connected to the IR sensor in order to avoid having the interface harness extra length tied up close to the IR sensor. The extra-length will be looped and tied to close harnesses later on as shown on FIGURE 31.



FIGURE 31

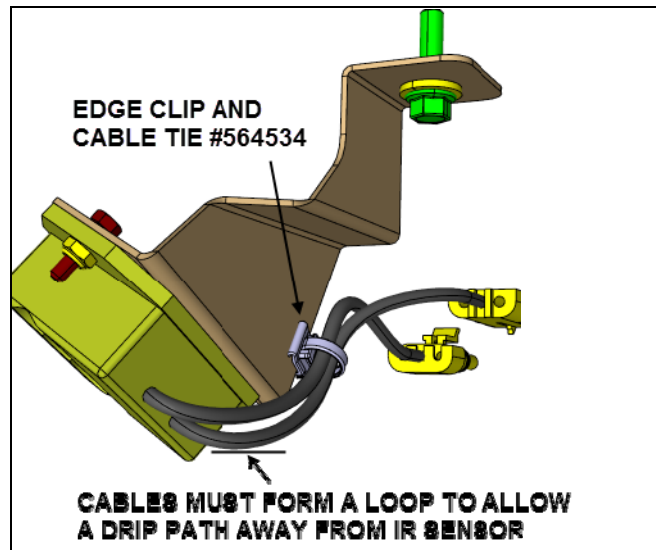

FIGURE 32

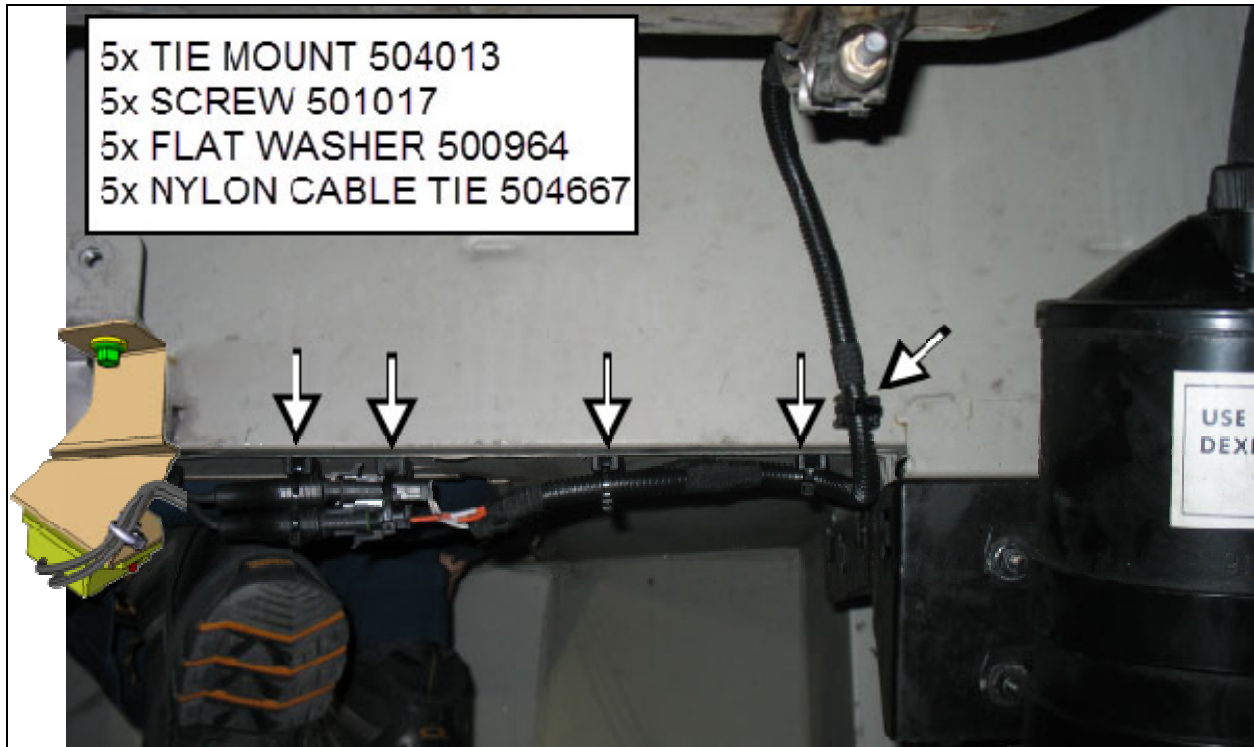

FIGURE 33

- 3) Connect the interface harness to the IR sensor. Secure IR sensor connectors as shown on FIGURE 32 and FIGURE 33 using 5 screws 501017 (pre-drilling diameter= 1/8 in), 5 flat washers 500964, 5 tie mounts 504013, 5 nylon cable ties 504637 and 1 edge clip 564534. The IR sensor cables must form a loop to allow a drip path away from the IR sensor.
- 4) Secure the extra-length of interface harness to close harnesses as shown on FIGURE 31, using nylon cable ties 504637.
- 5) Put fuse F45 back in place. Set the battery master switch to the ON position.
- 6) Set the ignition switch to the ON position and check that the driver's area AFSS protection panel SYSTEM OK green lamp is illuminating and that no fire detected/extinguisher discharge condition has been triggered. If no Kidde valve simulator is installed, the TROUBLE lamp should illuminate steady, indicating there is a fault in the extinguishing circuit, which is normal if the extinguisher circuit is not connected to the extinguisher bottle. The TROUBLE lamp will blink if there is a fault in the detection circuit.

If the ALARM lamp illuminates steady, a fire detected and extinguisher discharge conditions exist. Do not connect the extinguisher bottle to the extinguishing circuit.
- 7) If no fire detected/discharge condition exists, you can disconnect the valve simulator and plug the extinguisher bottle to the wiring harness of the extinguishing circuit.

PART 10 – ROUTING INTERFACE HARNESS UP TO THE IR SENSOR (H3 SERIES)

- 1) Route the interface harness up to the IR sensor new location. Unlike the LTD, the interface harness is routed on the curbside vehicle structure, attached to existing harnesses using nylon cable ties. See images below.

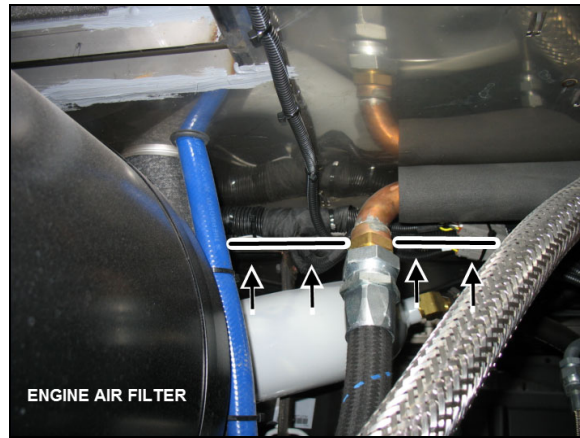
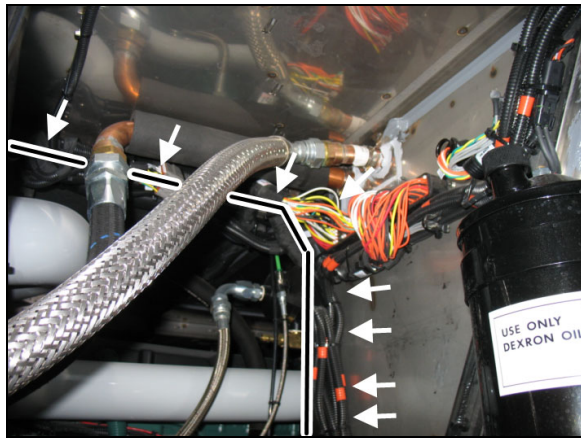
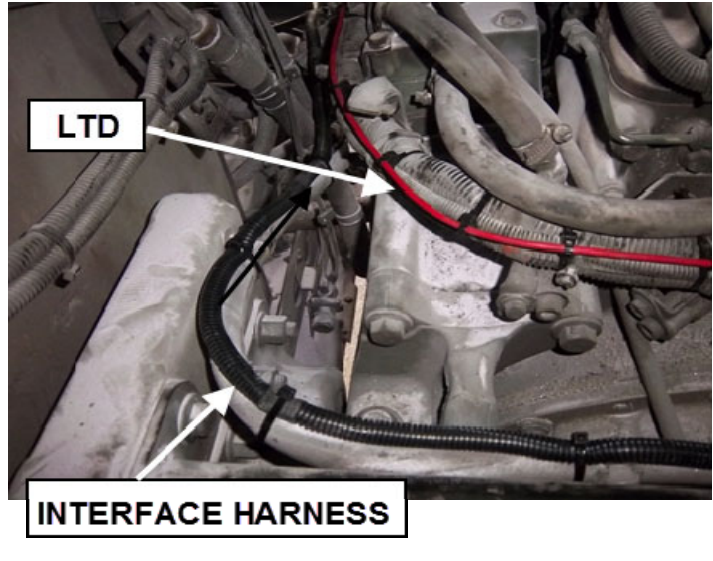
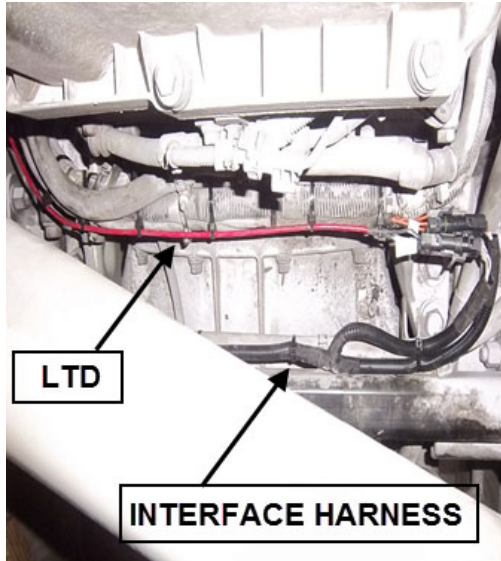

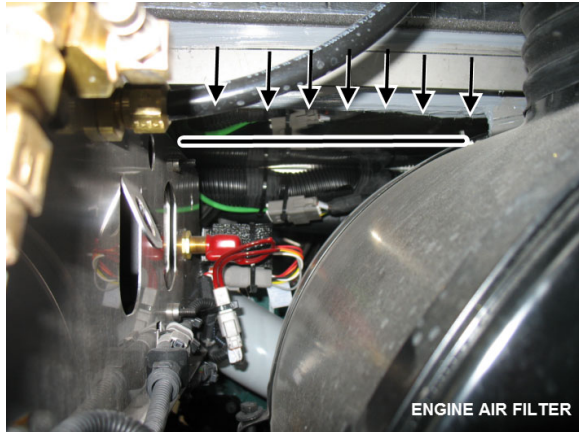

STEP 1 E

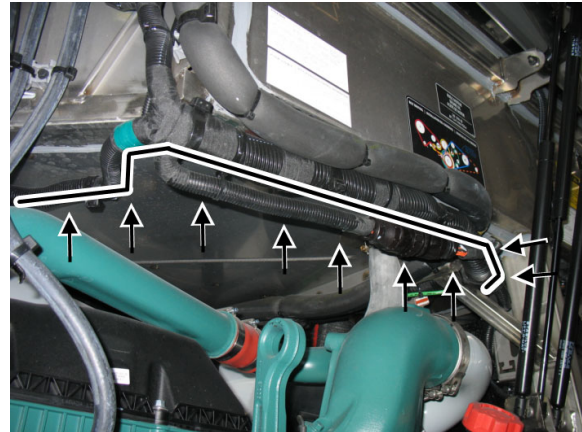

STEP 1 F



STEP 1 G

- 2) Connect the interface harness to the IR sensor (FIGURE 34).
- 3) Secure the interface harness connectors to close existing harness using three nylon cable ties #504637. The IR sensor cables must form a loop to allow a drip path away from the IR sensor (FIGURE 34, FIGURE 35).
- 4) Put fuse F45 back in place. Set the battery master switch to the ON position.
- 5) Set the ignition switch to the ON position and check that the driver's area AFSS protection panel SYSTEM OK green lamp is illuminating and that no fire detected/extinguisher discharge condition has been triggered. If no Kidde valve simulator is installed, the TROUBLE lamp should illuminate steady, indicating there is a fault in the extinguishing circuit, which is normal if the extinguisher circuit is not connected to the extinguisher bottle. The TROUBLE lamp will blink if there is a fault in the detection circuit.

If the ALARM lamp illuminates steady, a fire detected and extinguisher discharge conditions exist. Do not connect the extinguisher bottle to the extinguisher circuit.

- 6) If no fire detected/discharge condition exists, you can disconnect the valve simulator and plug the extinguisher bottle to the wiring harness of the extinguishing circuit.

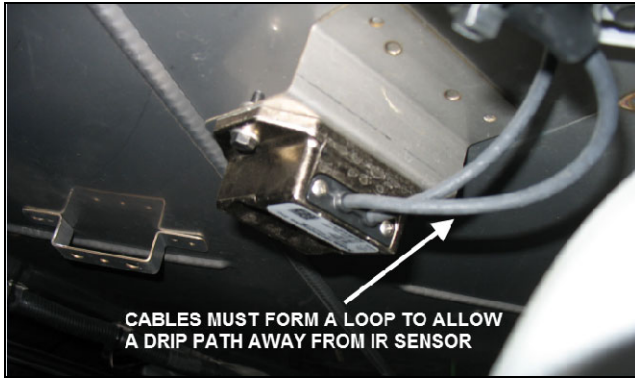

FIGURE 34

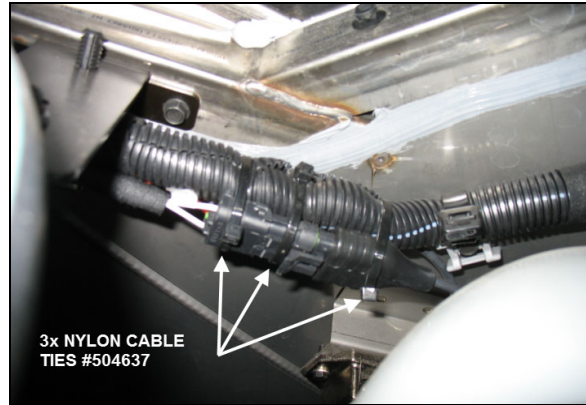

FIGURE 35

PARTS / WASTE DISPOSAL

Discard waste according to applicable environmental regulations (Municipal/State[Prov.]/ Federal)

Do not reuse the old IR sensor as it may fail prematurely and offer no protection.

WARRANTY

This modification is covered by Prevo's normal warranty. We will reimburse you the parts and 4 ½ hour(s) (4.5) of labor upon receipt of a warranty claim. Please submit claim via our Online Warranty System, available at www.prevo.com (under Service \ Warranty section). Use Claim Type: "Bulletin/Recall" and select "Warranty Bulletin SR15-30A".

OTHER

VBC Bulletin	N/A
Fail Code	23.08
Defect Code	09
Syst.Cond	R
Causal Part	068552

Access all our Service Bulletins on <https://secureus5.volvocars.com/technicalpublications/en/pub.asp> or scan the QR-Code with your smart phone.

E-mail us at technicalpublications_prev@volvo.com and type "ADD" in the subject to receive our warranty bulletins by e-mail.



INTENTIONALLY LEFT BLANK

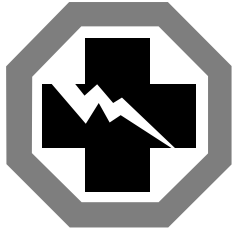

Safety Recall Certification Sheet (Ref: SR15-30A)

VEHICLE SERIAL NUMBER:

2	P	C																	
---	---	---	--	--	--	--	--	--	--	--	--	--	--	--	--	--	--	--	--

PERFORMED BY		OWNER/OPERATOR	
We hereby certify that Safety Recall Instructions with regard to Safety Recall SR15-30A have been performed.			
Name: _____	Name: _____		
Addr: _____	Addr: _____		
Phone: _____		Phone: _____	
Fax: _____		Fax: _____	
Signature : _____	Signature : _____		
Date: _____	Date: _____		

If the information mentioned above is incorrect or you are not the owner of this vehicle anymore, please fill this section and return to sender.

NEW OWNER: _____

BUSINESS: _____

ADDRESS (including County): _____

TELEPHONE: _____ **FAX:** _____

Please return this completed document with your A.F.A. form