

PREVOST

WARRANTY BULLETIN

WB15-53A

DATE :	NOVEMBER 2015	SECTION :	04 - Exhaust
EXPIRATION:	NOVEMBER 2017		
SUBJECT :	DIESEL PARTICULATE FILTER (DPF) – LOOSE PLUGS		

APPLICATION

NOTICE TO SERVICE CENTERS <i>Verify vehicle eligibility by checking warranty bulletin status with SAP or via ONLINE WARRANTY SYSTEM available on Service / Warranty tab of Prevost website.</i>		
Model	VIN	
H3-41, H3-45 coaches Model Year : 2015 - 2016	From 2PCH33497FC71 <u>2818</u> up to 2PCH33497GC71 <u>3095</u> incl.	
H3-45 VIP motorhomes Model Year : 2015 - 2016	From 2PCVS3498FC71 <u>2820</u> up to 2PCV33490GC71 <u>3071</u> incl.	
X3-45 coaches Model Year : 2015 - 2016	From 2PCG33497FC73 <u>5799</u> up to 2PCG33499GC73 <u>5949</u> incl.	
X3-45 VIP motorhomes Model Year : 2015 - 2016	2PCBS3498FC73 <u>5808</u> 2PCBS3491FC73 <u>5892</u> 2PCBS3497FC73 <u>5816</u> 2PCBS3493FC73 <u>5909</u> 2PCBS3490FC73 <u>5818</u> 2PCBS3499FC73 <u>5915</u> 2PCBS3496FC73 <u>5838</u> 2PCBS3496FC73 <u>5922</u> 2PCBS3493FC73 <u>5859</u> 2PCBS3493GC73 <u>5927</u> 2PCBS3499FC73 <u>5865</u> 2PCBS3492GC73 <u>5935</u>	
X3-45 VIP commercial use Model Year : 2015 - 2016	From 2PCCS3498FC73 <u>5800</u> up to 2PCC33499GC73 <u>5951</u> incl.	
This bulletin does not necessarily apply to all the above-mentioned vehicles, some vehicles may have been modified before delivery. The owners of the vehicles affected by this bulletin will be advised by a letter indicating the Vehicle Identification Number (VIN) of each vehicle concerned.		

DESCRIPTION

On the vehicles covered by this bulletin, two DPF (diesel particulate filter) plugs may be loose. If a plug is loose, it may fall out under the effect of vibration. This may cause leakage of hot exhaust gases.

It is therefore necessary to check if the plugs are tight and to tighten them properly if applicable.

PROCEDURE



DANGER

Park vehicle safely, apply parking brake, stop engine. Prior to working on the vehicle, set the ignition switch to the OFF position and trip the main circuit breakers equipped with a trip button. On the Commuter type vehicles, set the battery master switch (master cut-out) to the OFF position.

FIRST PLUG

1. Check if the M20 hexagonal plug located to the right side of the DPF (see image at right) is properly tightened.

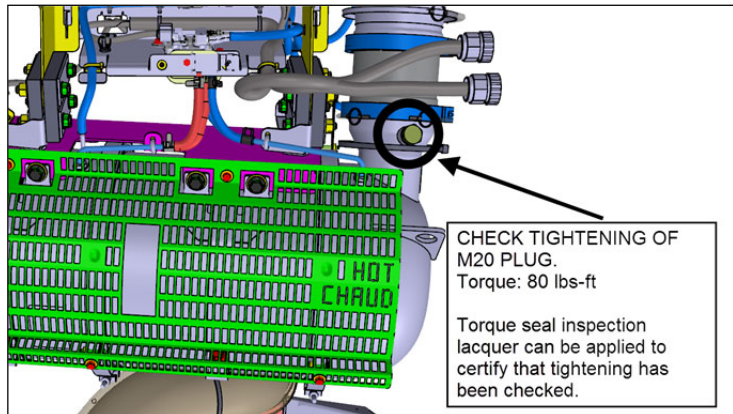

Note: To gain access to the plug, detach the Velcro strip on the insulating sleeve.

2. Apply a torque of **80 lbf - ft**.

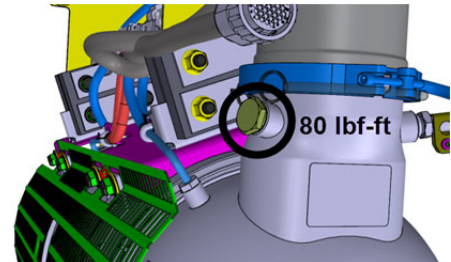

DANGER

If the plug is missing, order plug #20565546 and copper seal #947625.

THE VEHICLE MUST NOT BE USED IF A PLUG IS MISSING.

Note: You can apply torque seal inspection lacquer or similar product to certify that tightening has been checked.

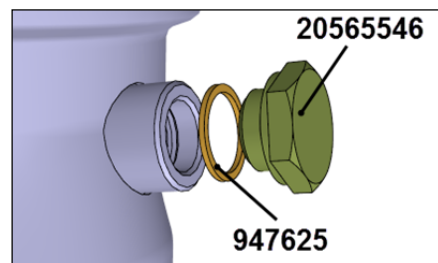

3. Attach the Velcro strip on the insulating sleeve once done.

SECOND PLUG

1. Check if the 1/8-27 NPT plug located to the left side of the DPF (at the inlet of DPF) is properly tightened.

Note: To gain access to the plug, detach the Velcro strip on the insulating sleeve.

2. Tighten 2 turns from finger tight (2 T.F.F.T.).

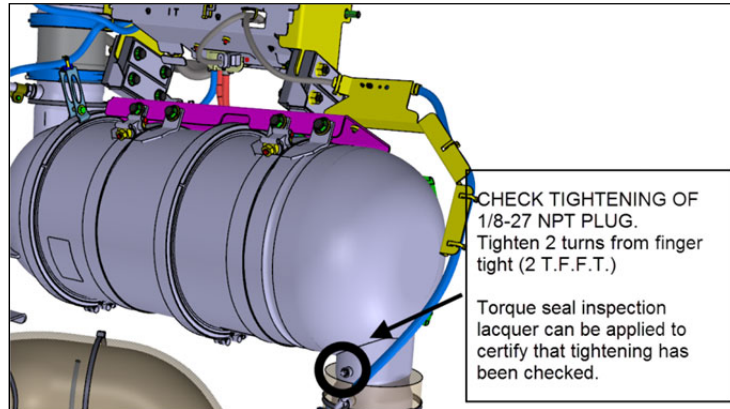

If the plug is missing, order plug #21305581.

THE VEHICLE MUST NOT BE USED IF A PLUG IS MISSING.

Note: You can apply torque seal inspection lacquer or similar product to certify that tightening has been checked.

Note: Copper anti-seize compound can be applied on this particular plug if necessary.

3. Attach the Velcro strip on the insulating sleeve once done.

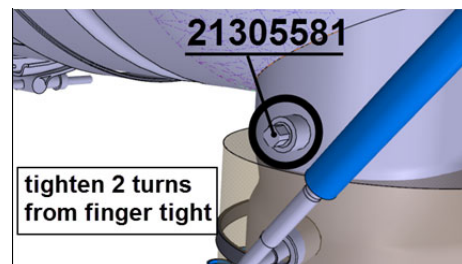

If one of the plugs was not adequately tightened or was missing, we would like to know. Please send a short message mentioning :

- The warranty bulletin number : WB15-53
- The vehicle serial number
- Please indicate if the plug was partially screwed, insufficiently tightened only or if the plug was missing (Please specify which plug)

Send to this address : technicalpublications_prev@volvo.com

WARRANTY

This modification is covered by Prevost's normal warranty. We will reimburse you 1/2 hour (0.5) of labor upon receipt of a warranty claim. Please submit claim via our Online Warranty System, available at www.prevostcar.com (under Service \ Warranty section). Use Claim Type: "Bulletin/Recall" and select "Warranty Bulletin WB15-53".

OTHER

VBC Bulletin	N/A
Fail Code	04-04-1
Defect Code	09
Syst. Cond	B
Causal Part	20565546

Access all our Service Bulletins on
<https://secureus5.volvo.com/technicalpublications/en/pub.asp>
or scan the QR-Code with your smart phone.
E-mail us at technicalpublications_prev@volvo.com and type
"ADD" in the subject to receive our warranty bulletins by e-mail.

