



**MAINTENANCE
INFORMATION**

MI17-03

| | | | |
|-----------|--|-----------|---------------|
| DATE : | January 2017 | SECTION : | 06 ELECTRICAL |
| SUBJECT : | Dash backlights always on after MUX update | | |

IMPORTANT NOTICE
This modification is recommended by PrevoSt to increase your vehicle's performance. Note that no reimbursement will be awarded for carrying out this modification.

APPLICATION

| Model | VIN |
|---|---|
| X3-45 coaches Model Year : 2010 - 2013 |  2PCG33498 <u>AC729907</u> , 2PCG33491 <u>AC729926</u> , 2PCG33499 <u>BC729965</u> , 2PCG33491 <u>BC729992</u> And From 2PCG33491 <u>BC735002</u> up to 2PCBS3490 <u>DC735458</u> incl. |

DESCRIPTION

After the installation of the latest Multiplex system update on US10 X3-Series coaches, the instrument panel and switches backlighting may stay constantly on due to an output (J1:4) on the A44 module sending constant current to the 114A circuit via the 2mph wire. This wire should be connected only for Commuter application and must be removed on coaches. To retain gateway module watchdog timer (WDT) function, a new wire must be routed and connected between module A44 output and the Gateway module. Refer to page 2 & 3 for complete instructions.

MATERIAL

Order the following parts:

| Part No | Description | Qty |
|---------|--|-------------|
| 562935 | Splice connector 22-18 w/shrink (bulk) | 2 |
| 562593 | Wire, Yellow 18ga (bulk) | 6ft / 1.80M |

NOTE
Material can be obtained through regular channels.

PROCEDURE



DANGER

Park vehicle safely, apply parking brake, stop engine. Prior to working on the vehicle, set the ignition switch to the OFF position and trip the main circuit breakers equipped with a trip button.

1. Inside the vehicle, remove the dash cover and locate the Gateway module.
2. Cut wire 12-439-18 going to the Gateway connector (leave about 3 inches of wire at the connector).
3. Inside the front junction box (FJB), locate module I/OB A44 and cut 2mph wire, leaving about 3 inches of wire at the connector end.
4. Using a splice connector #562935, connect a 6 ft. yellow 18ga wire (#562993) to the 2mph wire (connector side).
5. Pass the wire under the dash inside the driver's compartment (reach the Gateway module).
6. Connect the wire to the remaining 12-439-18 wire at the Gateway connector using a #562935 splice connector.

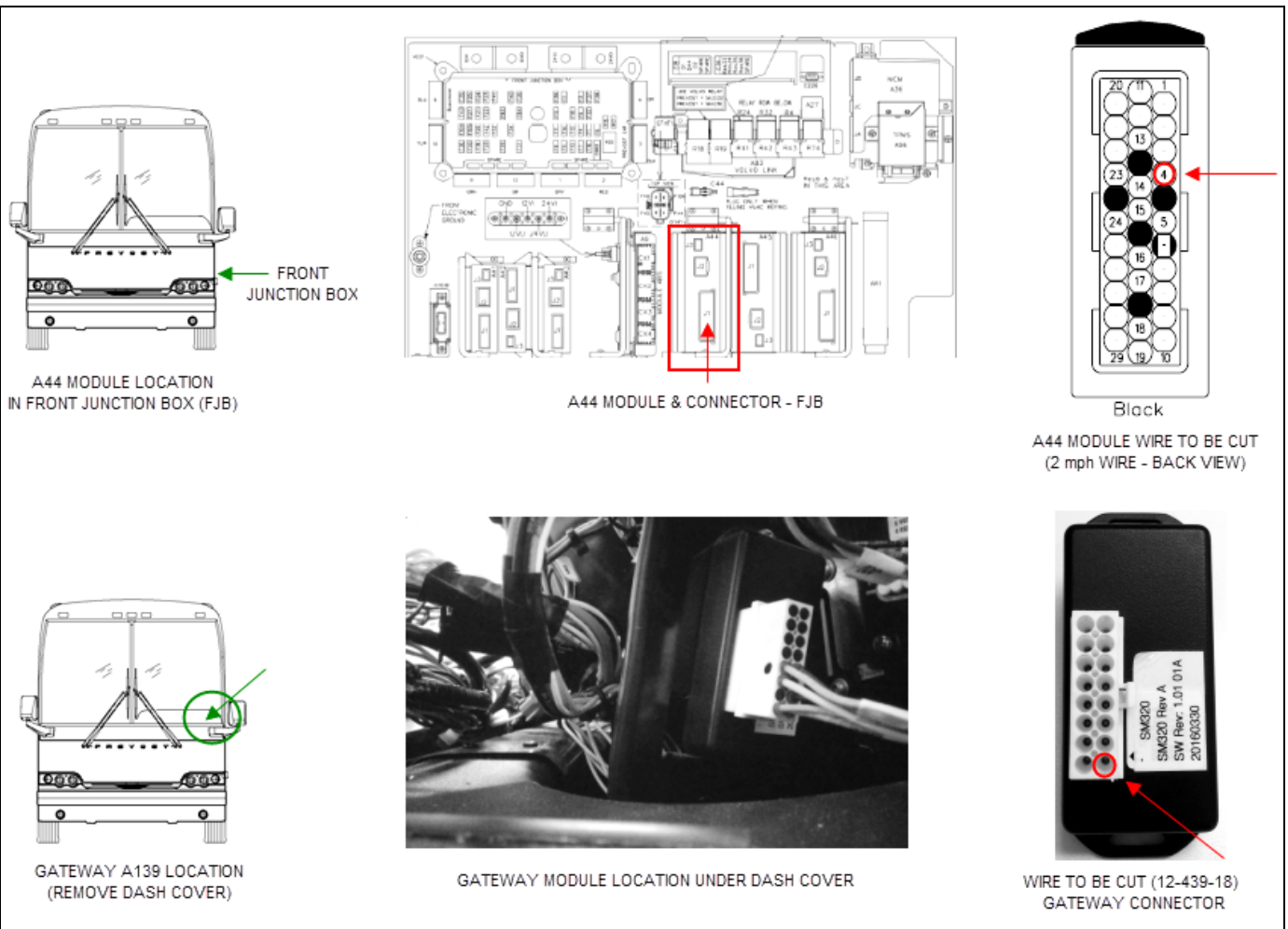

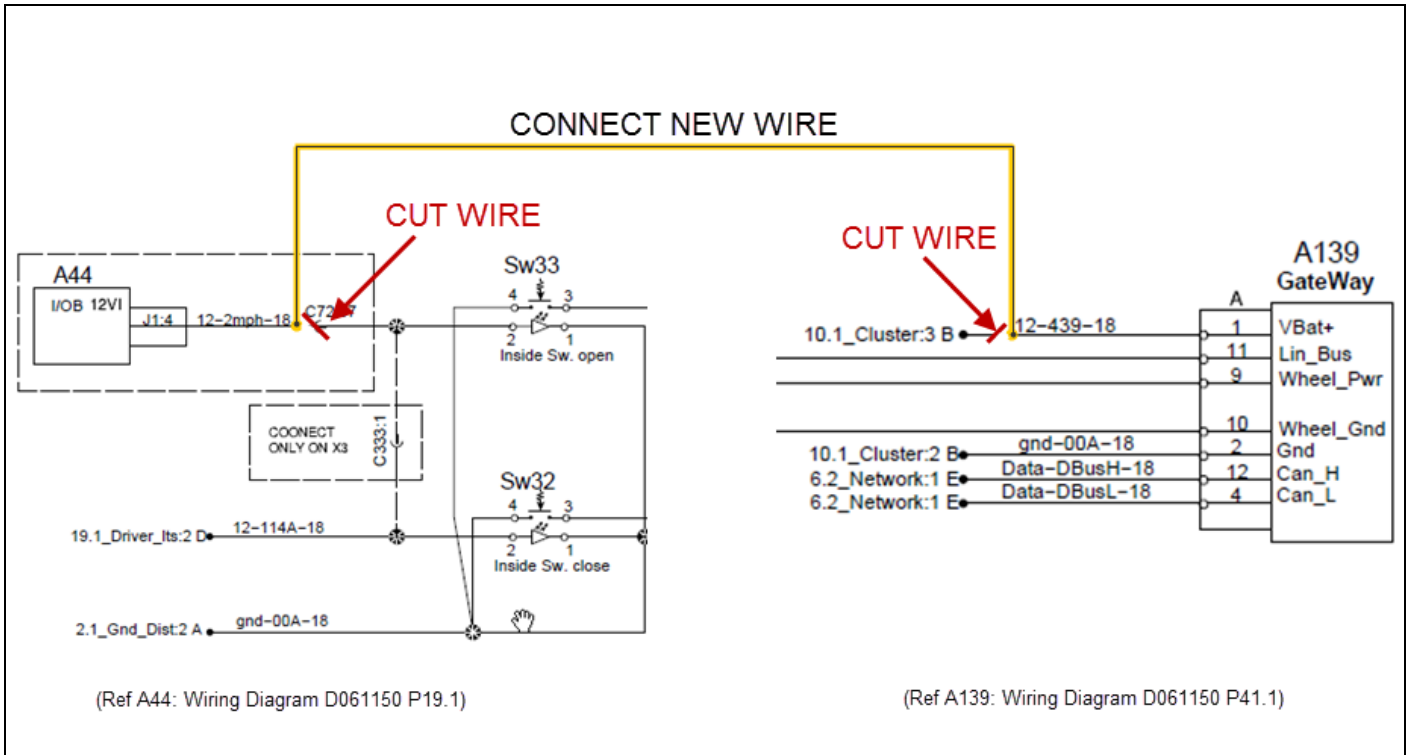

PARTS / WASTE DISPOSAL

Discard according to applicable environmental regulations (Municipal/State[Prov.]/ Federal)



Access all our Service Bulletins on <http://techpub.prevostcar.com/en/>
Or scan the QR-Code with your smart phone.

E-mail us at technicalpublications_prev@volvo.com and type "ADD" in the subject to receive our warranty bulletins by e-mail.