

PREVOST

Instruction Sheet

IS-17906A

ELD interface kit for Prevost Vehicles & Multiplex Detroit Diesel Engines

Revision A Connection to A45 module – simplified procedure

03-15-2019

APPLICATION

Model	VIN
H3 Series Vehicles Model Year : 2005 to 2008	From 2PCH33499 <u>5</u> 101 <u>0168</u> up to 2PCH334918 <u>8</u> C71 <u>1201</u> incl.
X3 Series Vehicles Model Year : 2007 to 2008	From 2PCG33494 <u>7</u> 102 <u>8933</u> up to 2PCG334918 <u>8</u> C72 <u>9449</u> incl.

MATERIAL

Kit #069798 includes the following parts:

Part No.	Description	Qty
061889	ELD Harness Pre-OBD13 (9 pin)	1
20890176P	Control Unit FMS Gateway – <i>pre-programmed*</i>	1
380120	Connector Bracket	1
380121	FMS Gateway Bracket	1
390038	ELD Decal	1
390039	OBD Decal	1
500855	Washer Flat N500 .188X.438X.049	2
502868	Screw TC TR PH N500 #10-16 X 1/2	6
504637	Cable tie Nylon STD Black	20
566004	Panel Nut Size 18	1
566006	Lock Washer for Panel Nut	1
560587	Ground terminal – Round (16-14) 1/4"	1
FI-17906	Instruction Sheet (FR)	1
IS-17906	Instruction Sheet (EN)	1

*FMS Gateway module was pre-programmed is ready to be installed in any vehicle using a Detroit Diesel engine.

NOTE

Material can be obtained through regular channels.

PROCEDURE



DANGER

Park vehicle safely, apply parking brake, stop engine. Prior to working on the vehicle, set the ignition switch to the OFF position and trip the main circuit breakers equipped with a trip button.

PART 1: FMS GATEWAY MODULE AND HARNESS INSTALLATION

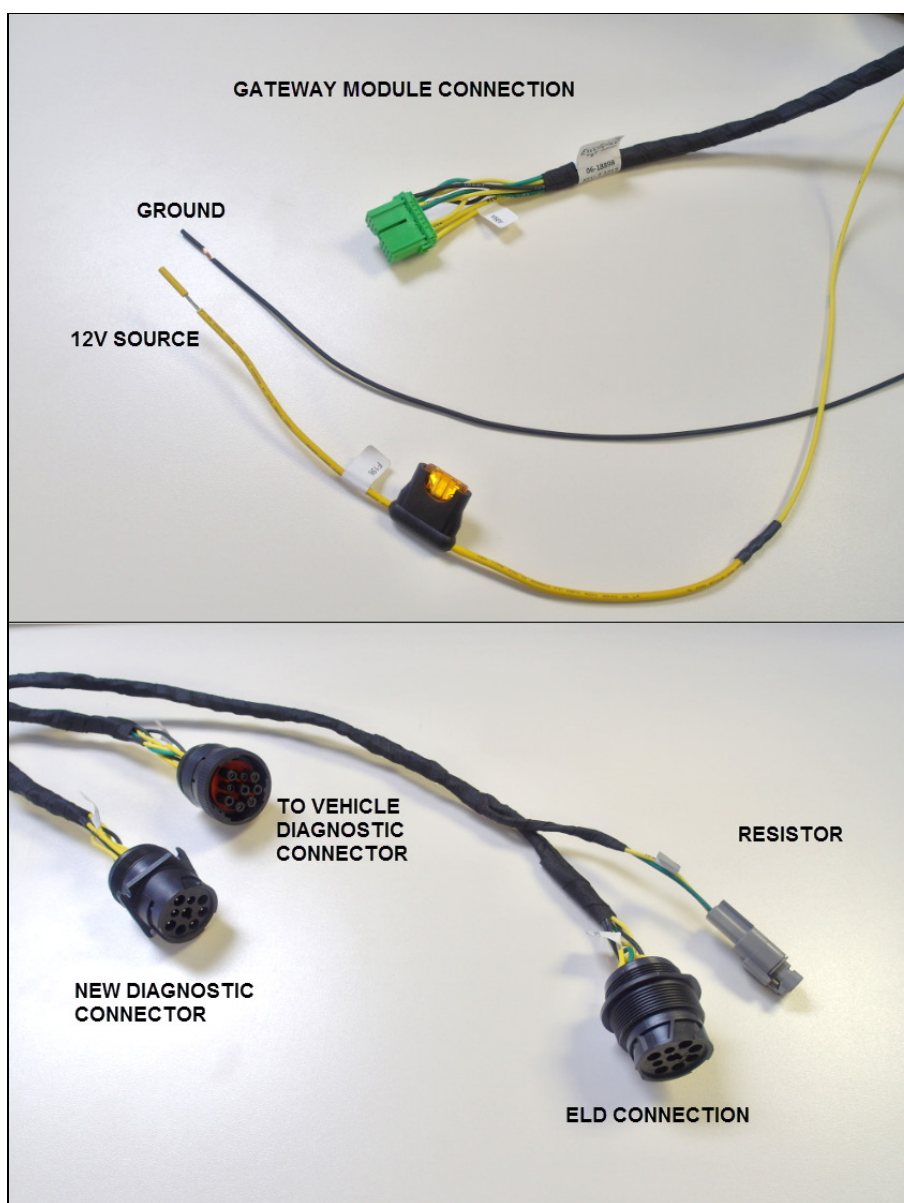

061889 - HARNESS CONNECTION IDENTIFICATION

1. Open the vehicle front electrical compartment door and remove/open the junction box protective panel.



FRONT JUNCTION BOX PROTECTIVE PANEL (H3 VEHICLE SHOWN)

2. Locate the future ELD gateway module (**20890176**) position at the left corner of the front junction box.



MODULE POSITION IN FRONT JUNCTION BOX (H3 SHOWN, X3 SIMILAR LOCATION)

3. Install the gateway module bracket (**380121**) on the “floor” of the junction box.
 - Bracket should be positioned as far rearward as possible (temporary install the module on the bracket – module should almost touch the back panel).

NOTE

Vehicles may already have two pre-drilled holes for bracket installation
– Make sure holes are positioned properly (far back) to clear vehicle harness and plastic protective panel before securing bracket/module.

- If no holes are factory drilled or if holes are not positioned properly, mark the bracket lower tab and screw hole positions with a sharpie and drill the two screw holes using an angle drill and a 9/64" (3mm) drill bit.
- Secure the bracket to the junction box floor using two of the supplied #10 screws (**502868**).

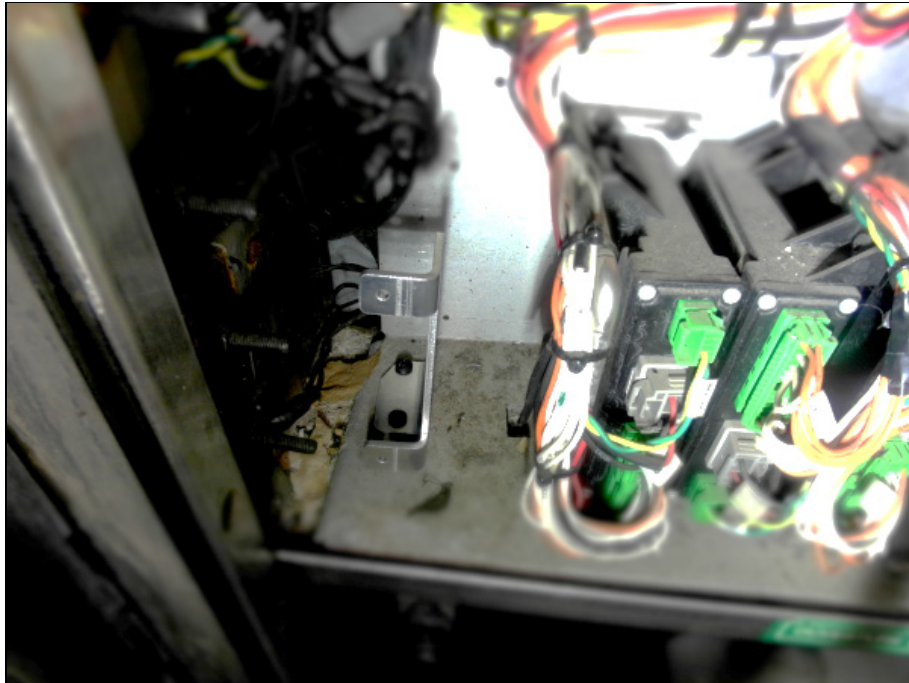

BRACKET POSITION

4. Secure the gateway module to the bracket using two supplied screws (**502868**) and flat washers (**500855**).



GATEWAY MODULE ON BRACKET – USE FLAT WASHERS

5. On H3 vehicles, remove the front junction box plastic gutter panel to allow direct access to the under dash area.

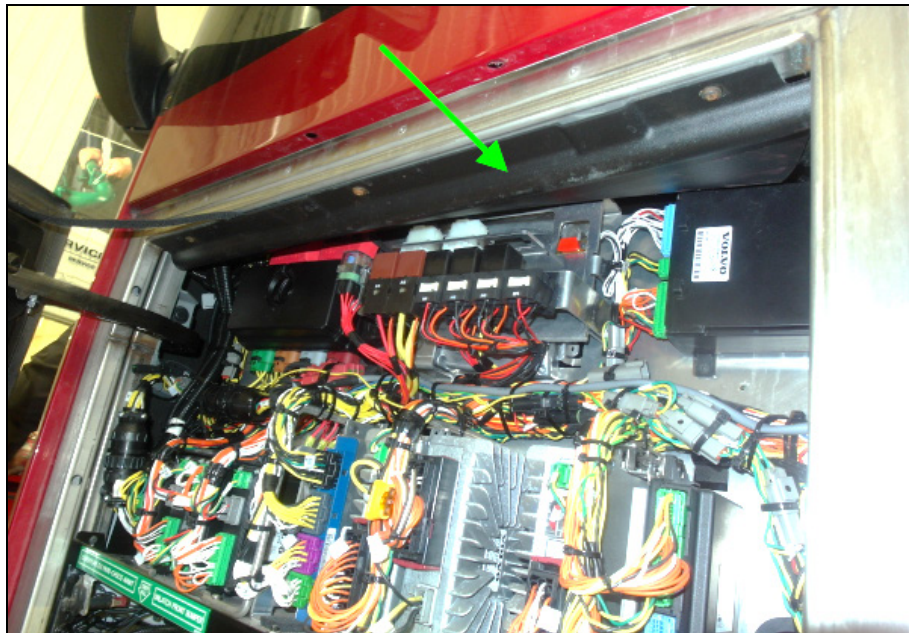

GUTTER PANEL; H3 VEHICLES ONLY

6. In the upper left corner of the front electrical compartment, locate the backside of the vehicle diagnostic connector. On X3 vehicles, the connector is easily accessible just below the side window. On H3 vehicle the connector is hidden under the vehicle body panel (above the fuse box, gutter panel must be removed).

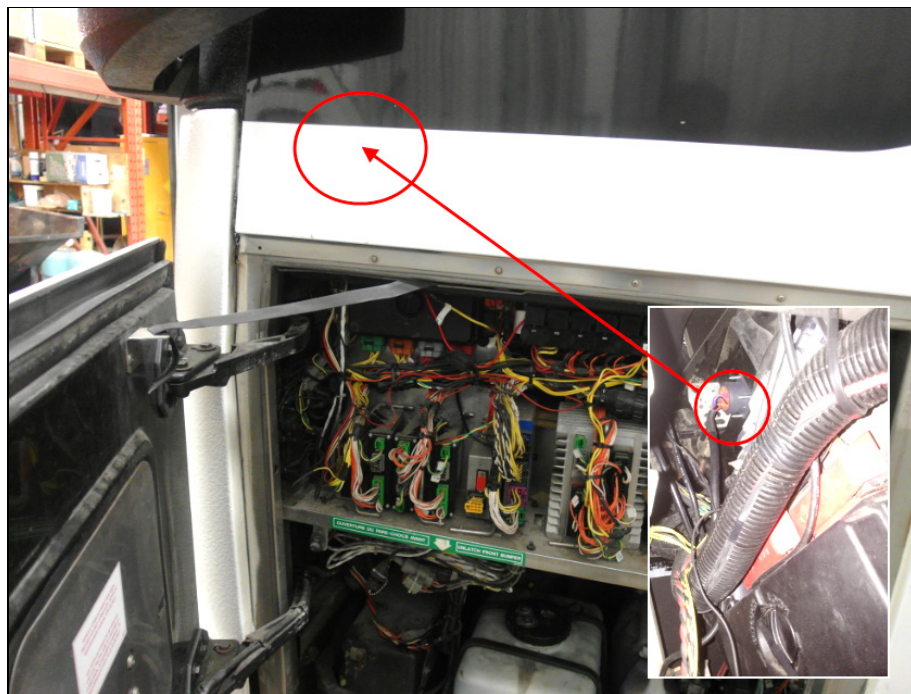

DIAGNOSTIC CONNECTOR POSITION (H3 VEHICLES)

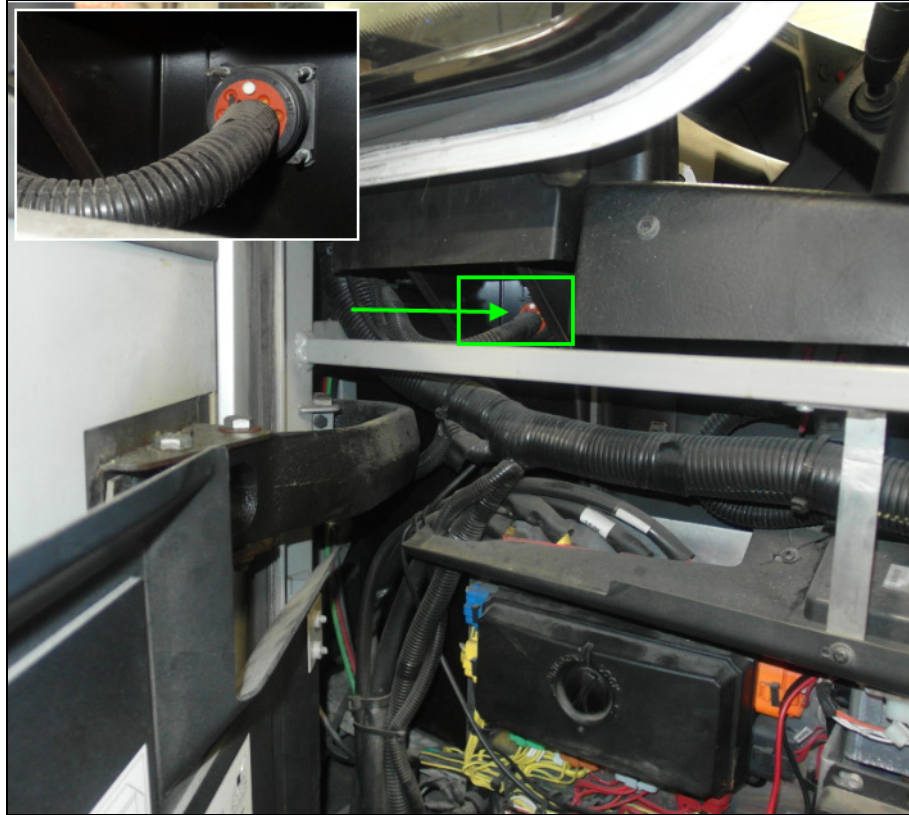

DIAGNOSTIC CONNECTOR POSITION (X3 VEHICLES)

7. Unscrew the connector from the vehicle lateral panel and remove from the opening. On H3 vehicles, the help of an assistant will be necessary to hold the screws in the driver area.



DIAGNOSTIC CONNECTOR SCREWS; BOTH SIDES

- Secure the ELD harness (061889) diagnostic connector (9 pin, square mounting plate with 4 holes) in the opening where the original vehicle diagnostic connector was (lateral panel). This connector will now be used for diagnostic procedure.

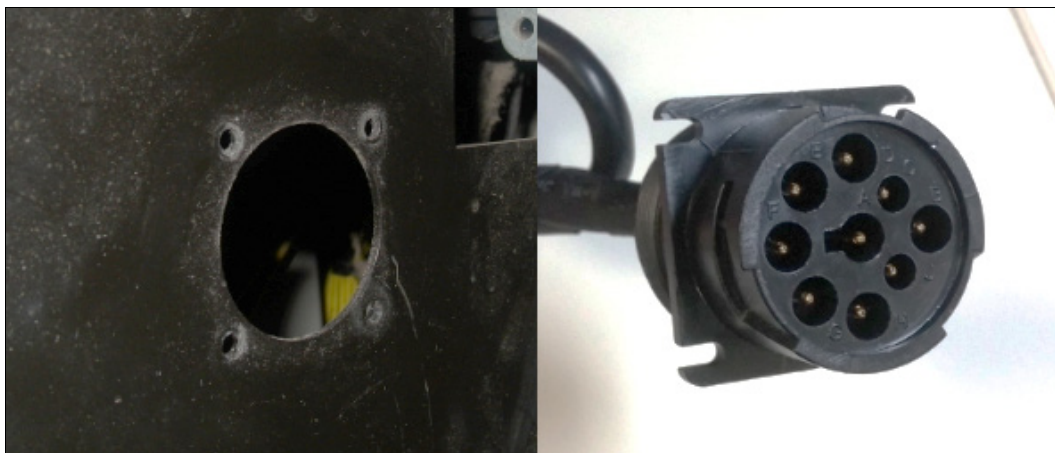

ELD HARNESS DIAGNOSTIC CONNECTOR OPENING

- Connect the ELD harness lockable (with lock ring) 9 pin connector to the original vehicle diagnostic connector (connector previously removed from opening). Secure this part of the harness with supplied cable ties (504637) so no parts are hanging.

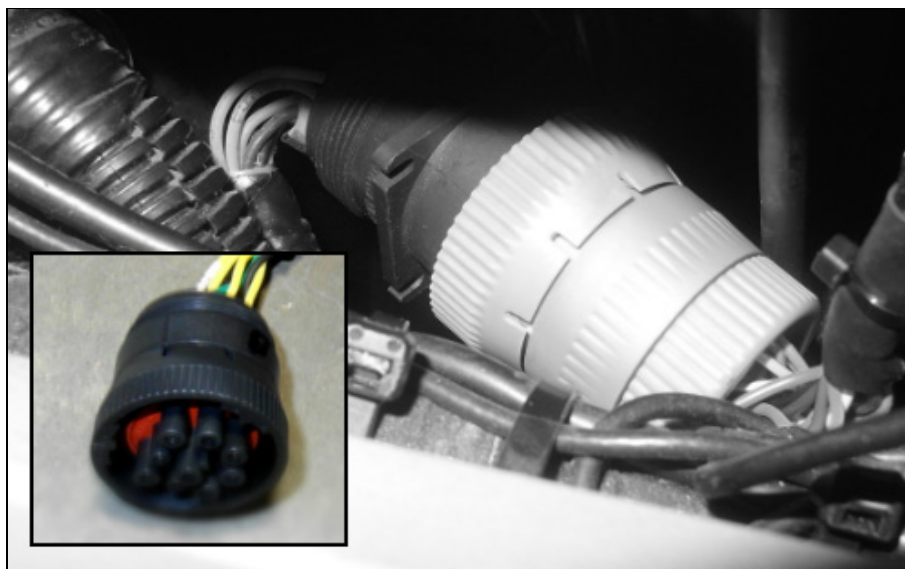

LOCK RING CONNECTOR: CONNECT TO ORIGINAL DIAGNOSTIC CONNECTOR

10. Route the last ELD 9 pin connector and the resistor part of the harness inside the vehicle (under dash area).

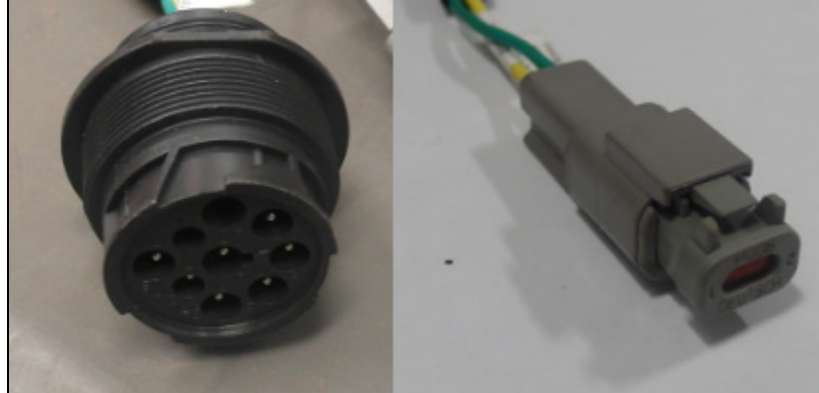

PASS INSIDE VEHICLE – UNDERDASH AREA

11. Connect the green harness connector to the gateway module.

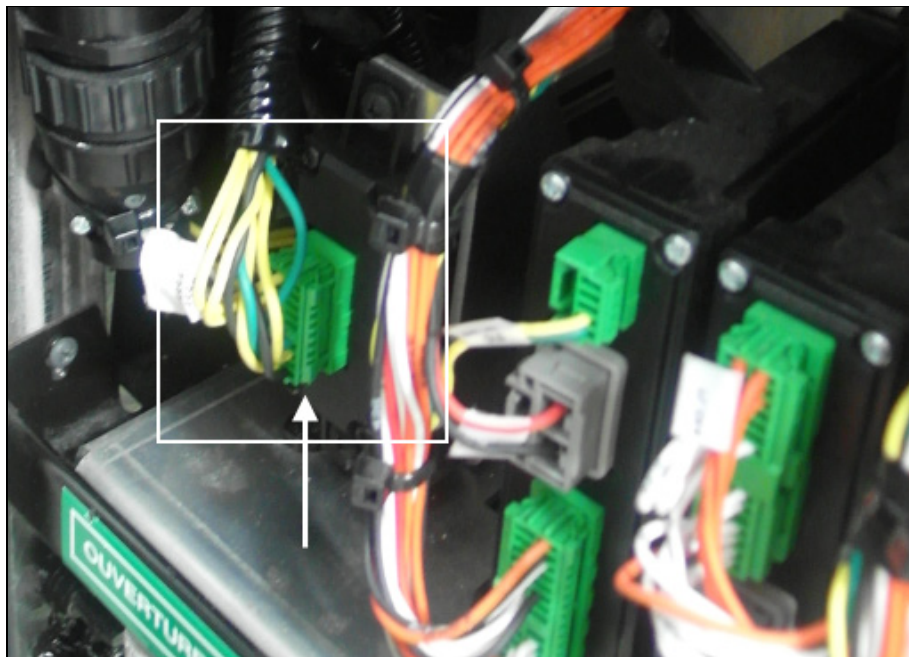

CONNECTED GATEWAY MODULE

12. Connect the 12V supply wire (fused - yellow wire) to the J2:2 wire of the A45 module connector.

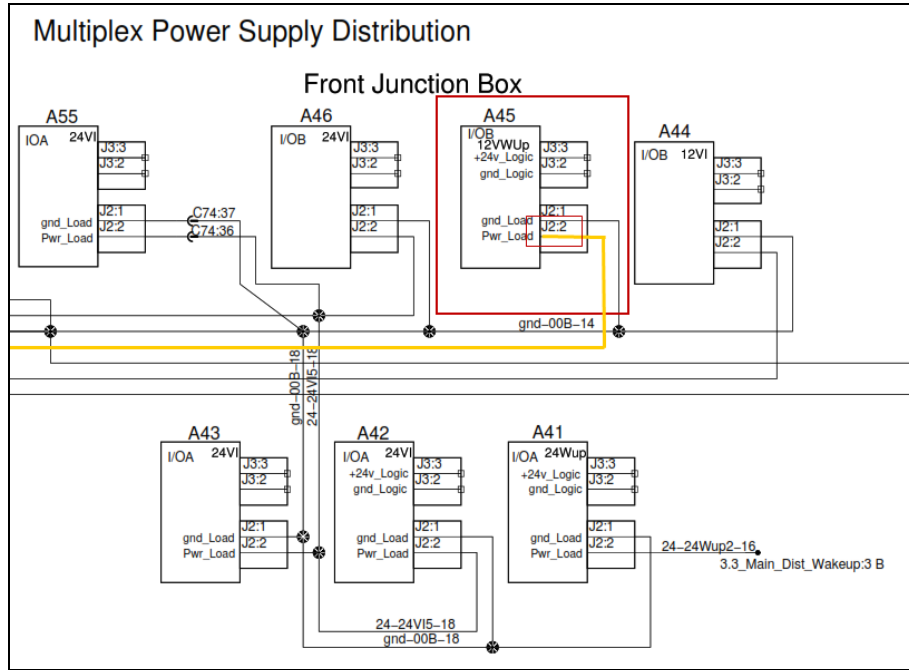

A45 MODULE & WAKE UP 12V POWER

p 7.1

- Disconnect the A45 module power (12V wake-up) connector (grey plug with yellow & black wires).

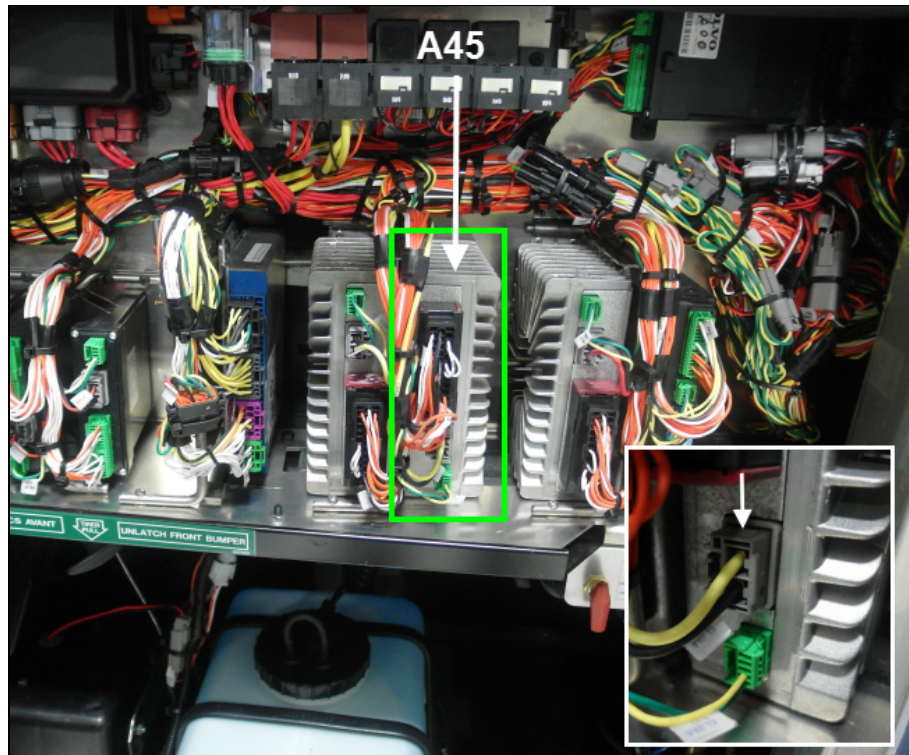

A45 MODULE AND GREY CONNECTOR (12V WAKE-UP)

- Lift the white locking bar located at the tip of the gray connector.

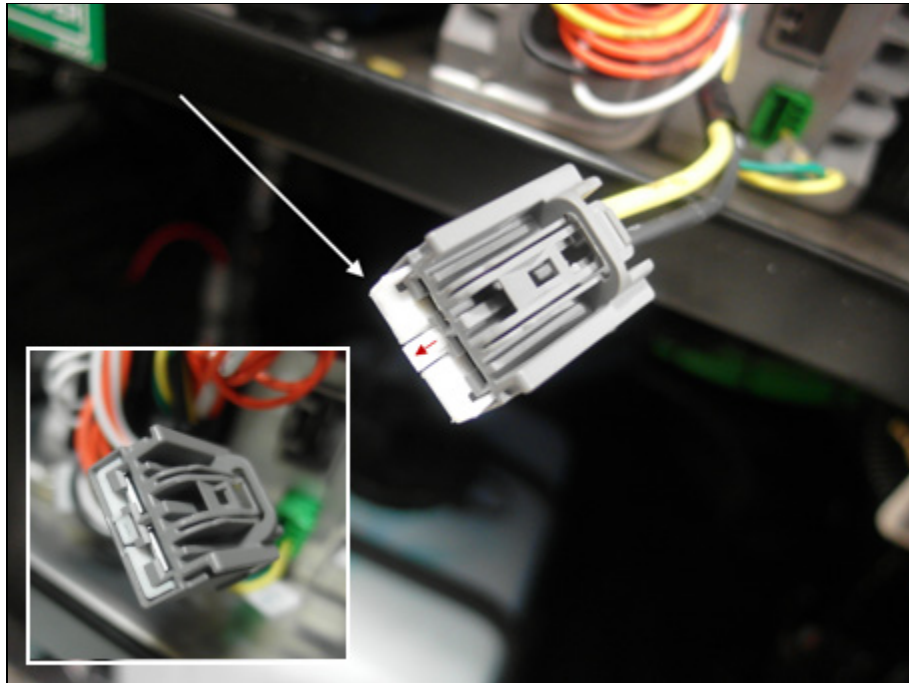

A45 MODULE CONNECTOR LOCKING BAR

- With a small flat screwdriver, press on the small tab located behind the locking bar to free the *J2:2 yellow wire* terminal.

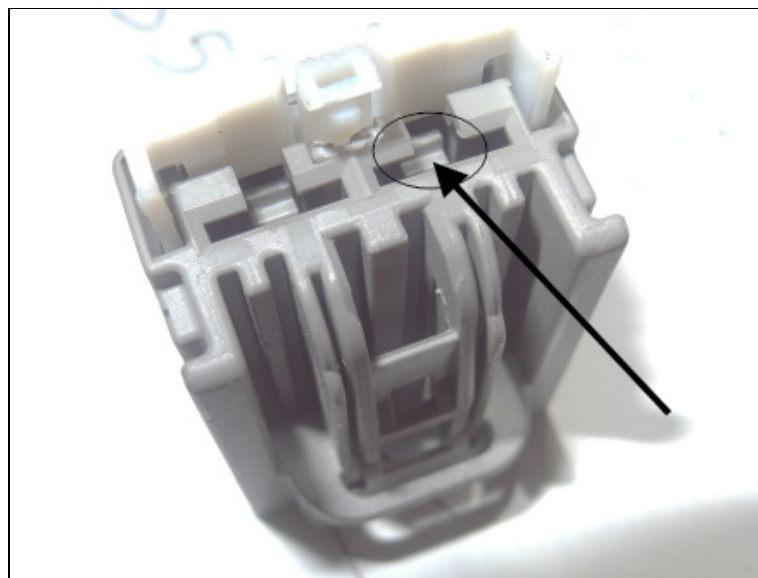

PRESS ON TAB TO FREE TERMINAL

- Cut a small section of the J2:2 yellow wire insulator +/- one inch below the terminal and splice it (Y-splice) with the ELD harness fused wire end. Solder the connection and add some heat shrink tubing to protect the connection.

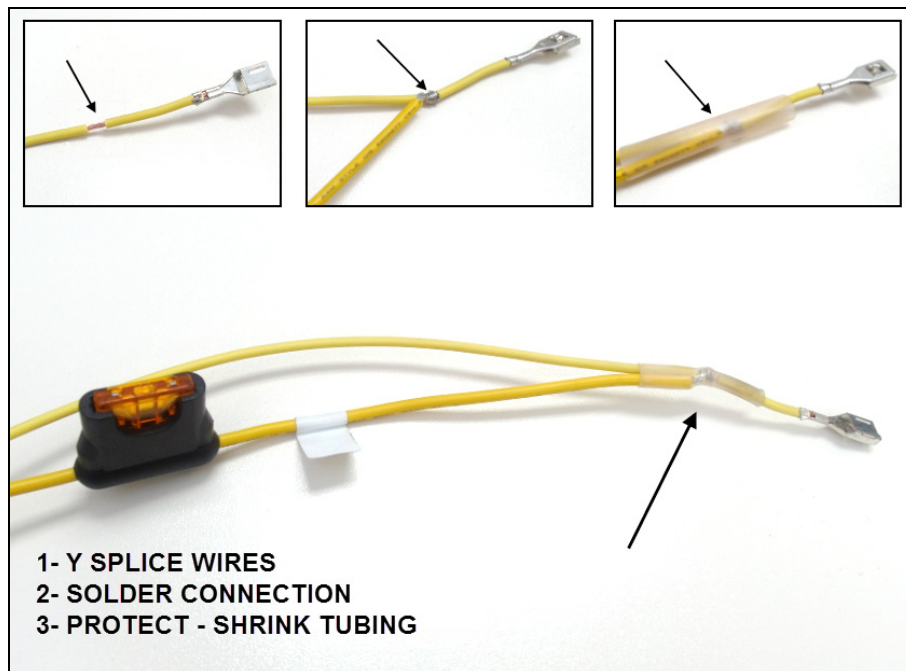

J2:2 WIRE & ELD FUSED WIRE JOINTED TOGETHER

- Reinsert terminal in the grey A45 module connector and push back the white locking bar.

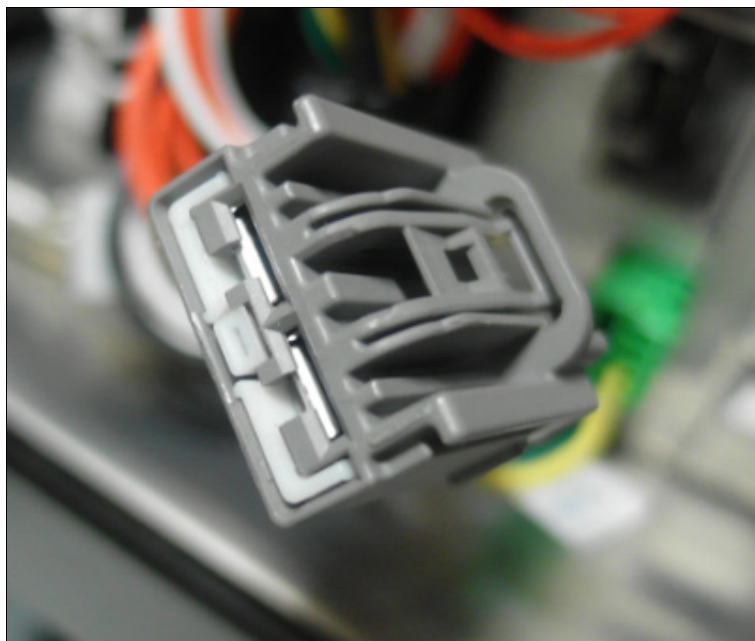

INSERT TERMINAL & LOCK

- Reconnect the A45 module.



A45 MODULE & ELD GATEWAY MODULE CONNECTION

13. Connect the ground (black) wire to one of the ground stud provided in the electrical compartment.
 - Locate ground studs located on the frame, next to the newly installed gateway module (H3 Vehicles) or just below the junction box floor (X3 Vehicles).

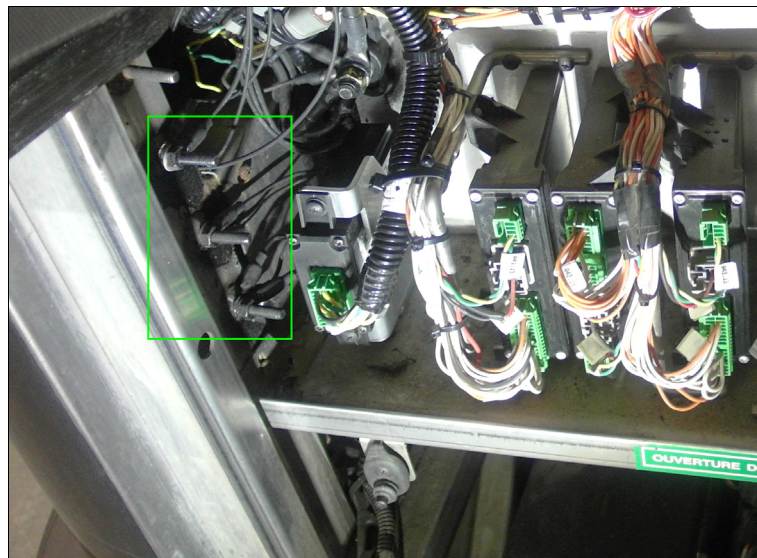

GROUND STUDS LOCATION IN FRONT COMPARTMENT H3 VEHICLES

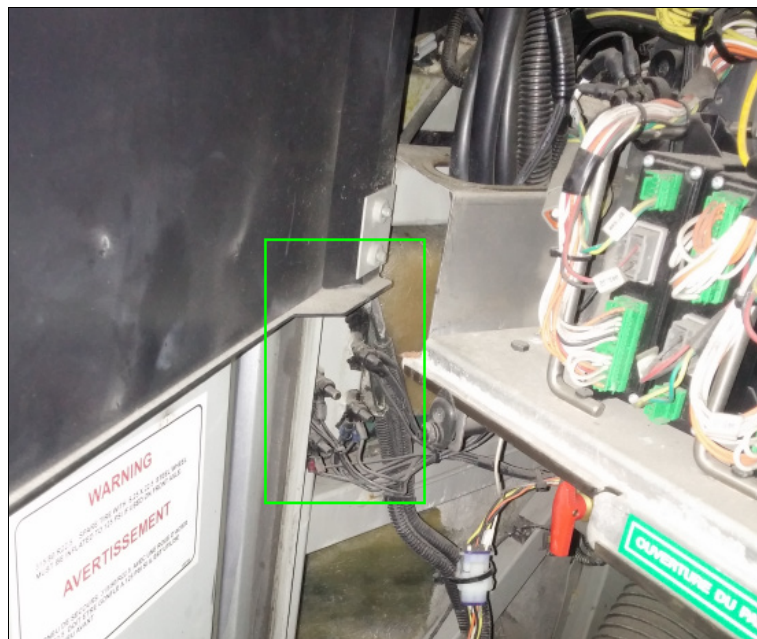

GROUND STUDS LOCATION IN FRONT COMPARTMENT (X3 VEHICLES)

- Clean one of the ground studs (remove black rubber guard protector).
- Crimp the supplied round terminal (**560587**) to the ELD harness black ground wire (cut/adjust length of the wire before crimping).

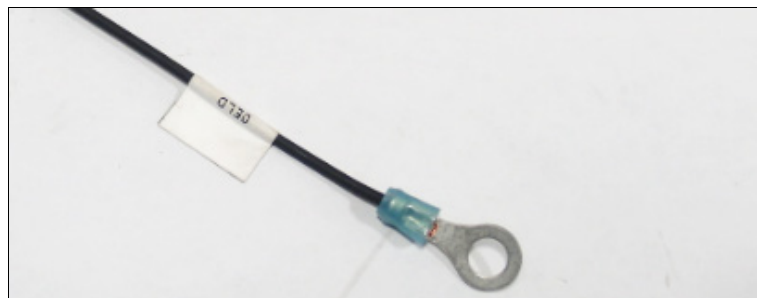

ROUND TERMINAL ON GROUND WIRE

- Connect the black wire to the chosen ground stud (re-apply rubber guard protector).



GROUND WIRE CONNECTED

14. Secure the harness in several places inside the front junction box using some of the supplied cable ties (504637). Harness should follow closely original harness in the front junction box and not hang or rub against components (pay close attention to contact between harness and upper door hinge).

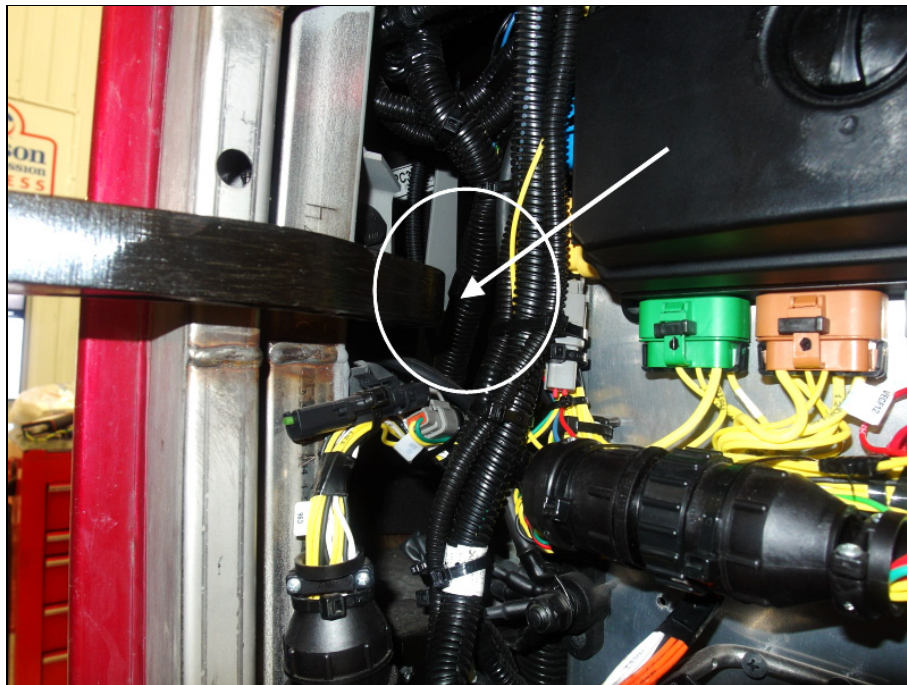

CHECK FOR CONTACT BETWEEN HINGE AND HARNESS (H3 SHOWN)

15. Reinstall the gutter panel (H3 vehicles). Check for interferences/contact between the ELD harness and the panel.



AVOID CONTACT HERE ON H3 VEHICLES

16. Put back/close the junction box protective panel (make sure the panel does not interfere with the gateway module wires and connector).

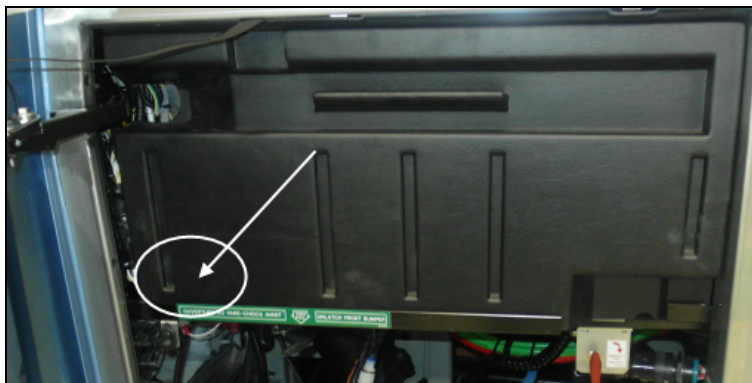

CHECK FOR INTREFERENCE – INSIDE PANEL & MODULE HARNESS

17. Inside the vehicle, install the ELD connector support bracket (**380120**) under the dashboard (left side close to the steering column) using the remaining #10 screws.



BRACKET POSITION UNDER DASH

18. Secure the ELD connector to the bracket using the provided plastic panel nut (**566004**) and washer (**566006**).

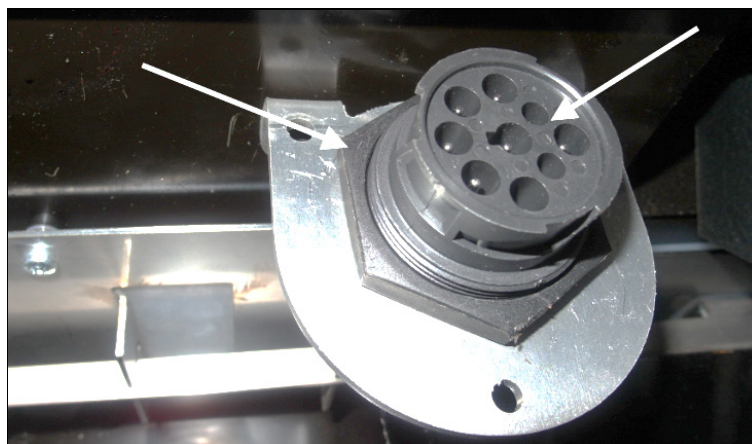

ELD CONNECTOR & BRACKET

19. Apply ELD decal (**390038**) on the dash just over the ELD connection and apply the diagnostic decal (**390039**) on the left molding, close to the diagnostic connector to finish the module and harness installation.

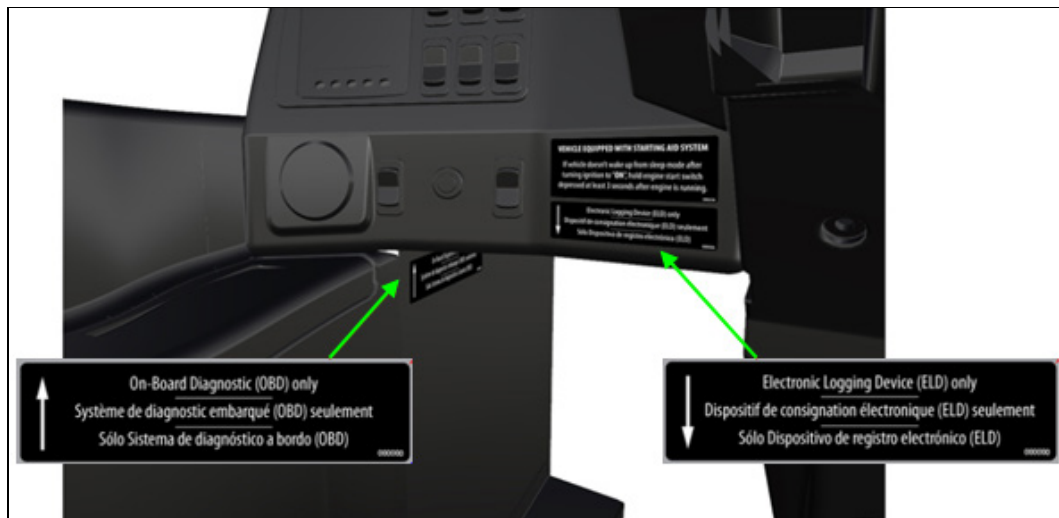

DIAGNOSTIC (OBD) & ELD DECALS

20. Refresh and delete codes.

PARTS / WASTE DISPOSAL

Discard waste according to applicable environmental regulations (Municipal/State[Prov.]/ Federal)