

PREVOST

Instruction Sheet

IS-16080

DRAIN HOLES IN WEILER SLIDE-OUT BASE SEAL

First release :

02-28-2019

MATERIAL

Order one of the following kits:

Part No.	Description	Qty
479427	Seal 1 VIP 45 Assy	1
479428	Seal 4 VIP 45 Assy	1
479429	Seal 4 VIP 45 Assy	1
479430	Seal 1 WE Assy	1
479431	Seal 2 WM Assy	1
479432	Seal 2 WM Assy	1
479433	Seal 1 WM Assy	1
479434	Seal 1 WM Assy	1
479435	Seal 2 WM Assy	1
479437	Seal 2 WM Assy	1
479438	Seal 2 WM Assy	1
479439	Seal 1 WM Assy	1

Other parts that may be required:

Part No.	Description	Qty
N/A	Hollow Punch – 1/2" (13mm)	1

NOTE

Material can be obtained through regular channels.

PROCEDURE



DANGER

Park vehicle safely, apply parking brake, stop engine. Prior to working on the vehicle, set the ignition switch to the OFF position and trip the main circuit breakers equipped with a trip button.

NOTE

When replacing slide-out seals on PrevoSt motorhomes and converted vehicles, the drain and air supply holes must be punched out of the base seal to allow proper draining of the seal and allow the inflatable seal hose to be connected to the air supply.

It is important to puncture these holes before installing the inflatable seal inside the base seals.

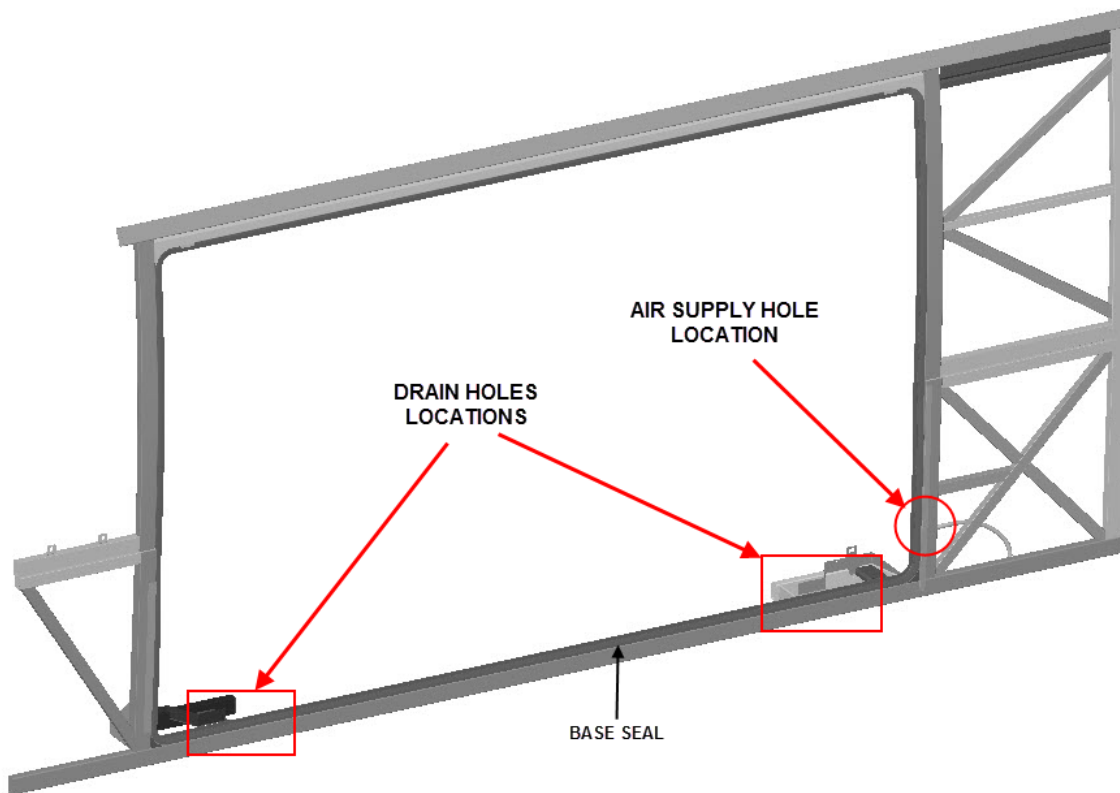

1. Before the installation of the base seal, mark the holes location on the vehicle slide-out frame.

- Mark the center of the drain holes locations on the frame. There are four holes on each extremity (lower left and right) of the frame as identified on the picture below. Also mark on which side (in or out) of the frame the holes must be drilled.

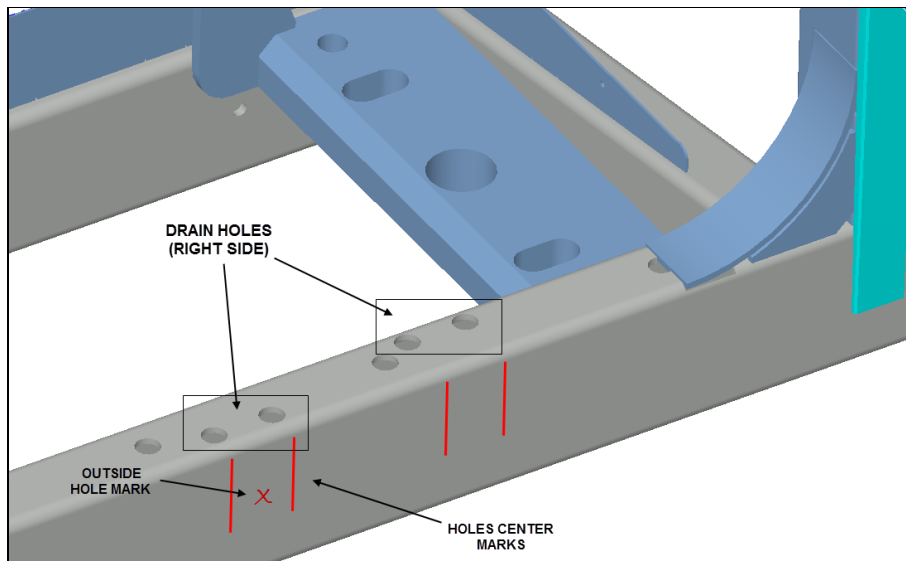

- Also mark the inflatable seal air supply hole on the side of the frame (this hole is centered).

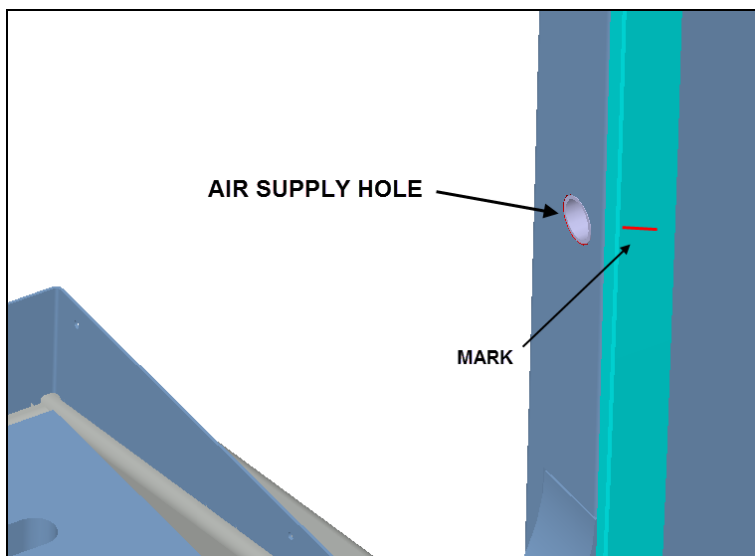

2. Install the base seal following current Prevest procedures (see [MI19-27](#)).

- Using a sharp blade or knife (X-Acto style) cut the inner lip passing over the drain holes on both side of the frame. Cut just enough clear the drain holes (42mm / 1.65in).

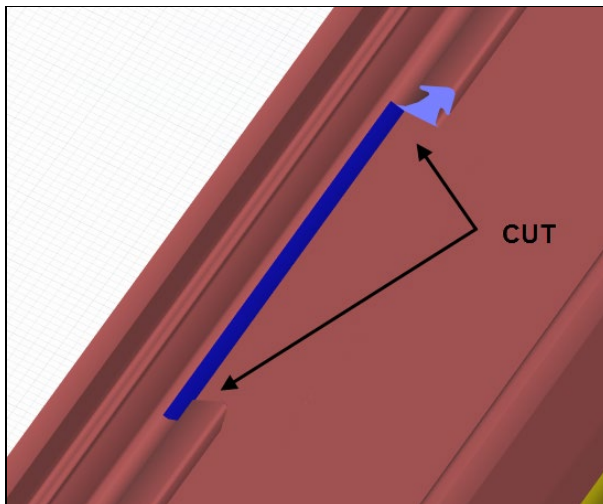

- Using a 1/2in (13mm) hollow punch, puncture the seal to relieve the drain holes and the air supply hole. Apply hand pressure and twist from left to right to cut through the seal.



WARNING

Do not hit the punch with a hammer to cut through the seal. Using this method could rupture or damage the seal.

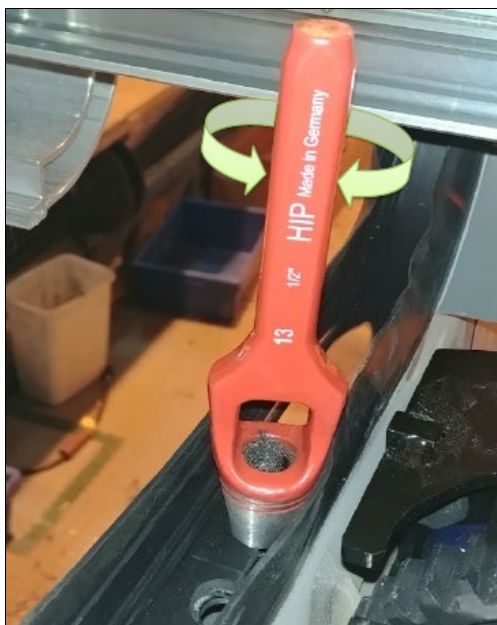

PARTS / WASTE DISPOSAL

Discard waste according to applicable environmental regulations (Municipal/State[Prov.]/ Federal)