

PREVOST

WARRANTY BULLETIN

WB23-16B

DATE :	November 2023	SECTION :	06 ELECTRICAL
EXPIRATION:	January 2026		
SUBJECT :	SOLUTION FOR BATTERY DRAIN ON VEHICLE NOT EQUIPED WITH A PREHEATER		

Revision: B

Vehicle range change

01-22-2025

APPLICATION



NOTICE TO SERVICE CENTERS	
<i>Verify vehicle eligibility by checking warranty bulletin status with SAP or via ONLINE WARRANTY SYSTEM available on Service / Warranty tab of Prevost website.</i>	
Model	VIN 
H3-45 coaches Model Year: 2019 - 2023	From 2PCH33490 <u>KC720656</u> up to 2PCH3349X <u>PC721451</u> incl.
X3-45 coaches Model Year: 2019 - 2023	From 2PCG33491 <u>KC736456</u> up to 2PCG33498 <u>PC736851</u> incl.
X3-45 coaches Model Year: 2019 - 2021	From 4RKG3349X <u>K9737620</u> up to 4RKG33496 <u>M9737763</u> incl.
X3-45 Commuter Model Year: 2019	From 4RKJ3349X <u>K9737543</u> up to 4RKJ33497 <u>K9737547</u> incl.
This bulletin does not necessarily apply to all the above-mentioned vehicles, some vehicles may have been modified before delivery. The owners of the vehicles affected by this bulletin will be advised by a letter indicating the Vehicle Identification Number (VIN) of each vehicle concerned.	

DESCRIPTION

On the vehicles affected by this bulletin, unplug connector CSX1 and CSX3 to prevent battery drain. This bulletin applies to vehicles not equipped with a preheater.

MATERIAL

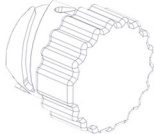
Order kit **WB23-16** which contains the following parts:

Part No.	Description	Qty
564069	SEALED CAP 	1
564660	CAP, PROTECTOR 	1
504637	CABLE TIE, NYLON BLK (STD)	4

NOTE

Material can be obtained through regular channels.

SAFETY PRECAUTIONS

- Eye protection should always be worn when working in a shop.
- Rules for Personal Protection Equipment should always be respected. Wear your PPE including but not limited to the following:



Safety First!



PROCEDURE



DANGER

Park vehicle safely, apply parking brake, stop the engine. Prior to working on the vehicle, set the ignition switch to the OFF position and trip the main circuit breakers equipped with a trip button. On the Commuter type vehicles, set the battery master switch (master cut-out) to the OFF position.

Lockout & Tag out (LOTO) must be performed during set-up, maintenance or repair activities. Refer to your local procedure for detailed information regarding the control of hazardous energy.

1. Locate the connector on the vehicle harness: refer to **figure 1** or **figure 2**

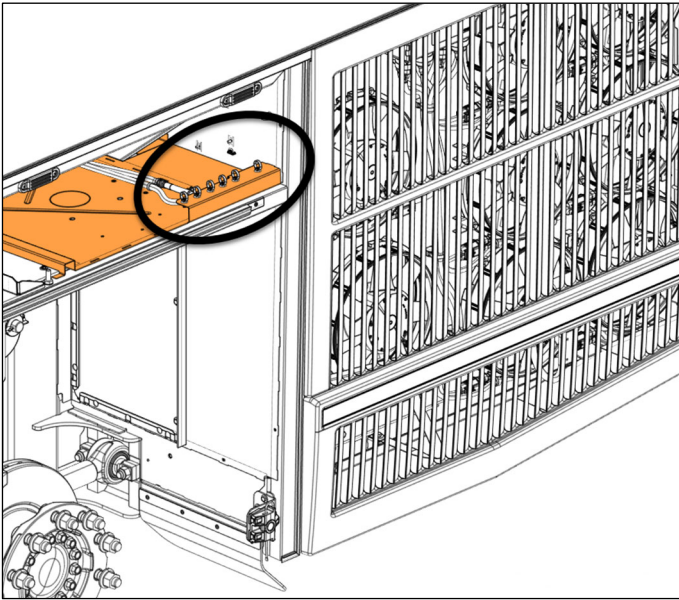

Figure 1: H3-45 Harness location

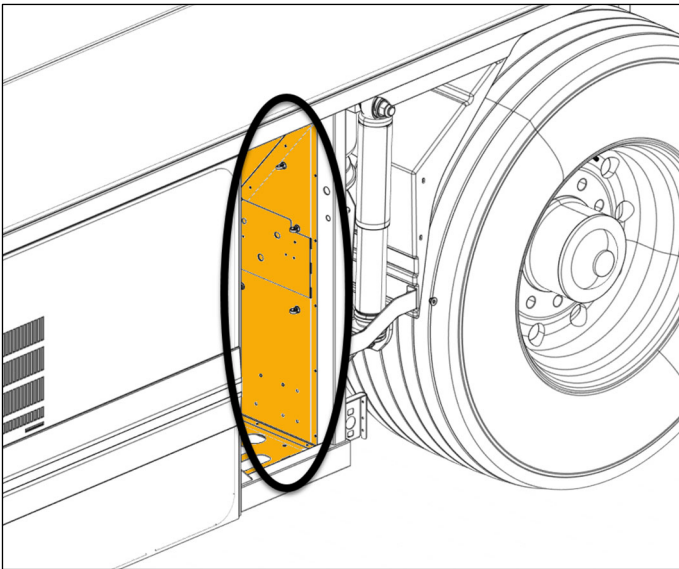
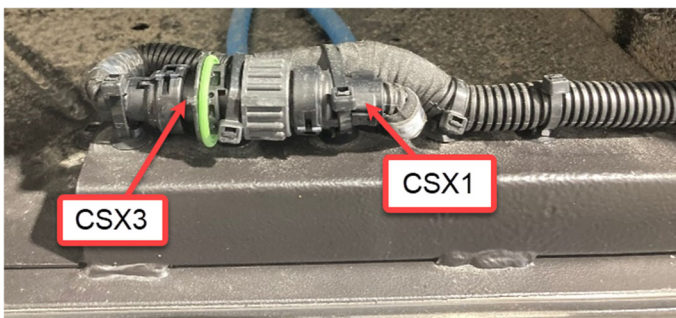
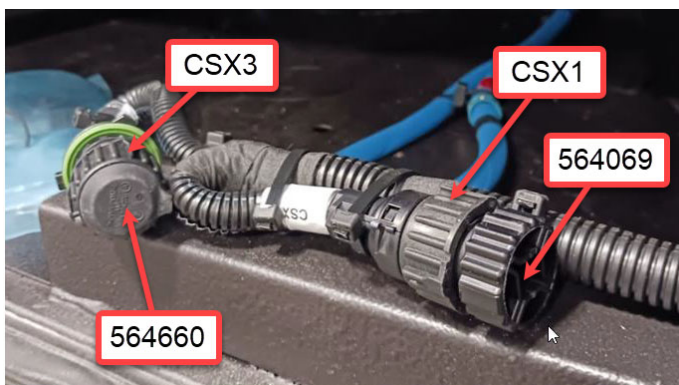

Figure 2: X3-45 Harness location

2. Unplug connector CSX1 and CSX3



3. On connector CSX1 install cap 564069. On connector CSX3 install cap 564660.



4. Secure harness with cable ties 504637 (4x).

WARRANTY

This modification is covered by Prevo's normal warranty. We will reimburse you the parts and 1/2 hour(s) (0.5) of labor upon receipt of a warranty claim. Please submit claim via our Online Warranty System, available at www.prevo.com (under Service \ Warranty section). Use Claim Type: "Bulletin/Recall" and select "Warranty Bulletin WB23-16B".

OTHER

VBC Bulletin	N/A
Fail Code	06.15
Defect Code	09
Syst. Cond	B
Causal Part	564069

Access all our Service Bulletins on
<http://techpub.prevo.com/en/>
or scan the QR-Code with your smart phone.



Are you a Vehicle owner? E-mail us at technicalpublications_prev@volvo.com and type "ADD" in the subject to receive warranty bulletins applicable to your vehicle(s) by e-mail.