



Service Data

SD-06-1804

Bendix® SL-5™ Stop Light Switch & Bendix® DS-2™ Combined Stop Light Switch & Double Check Valve

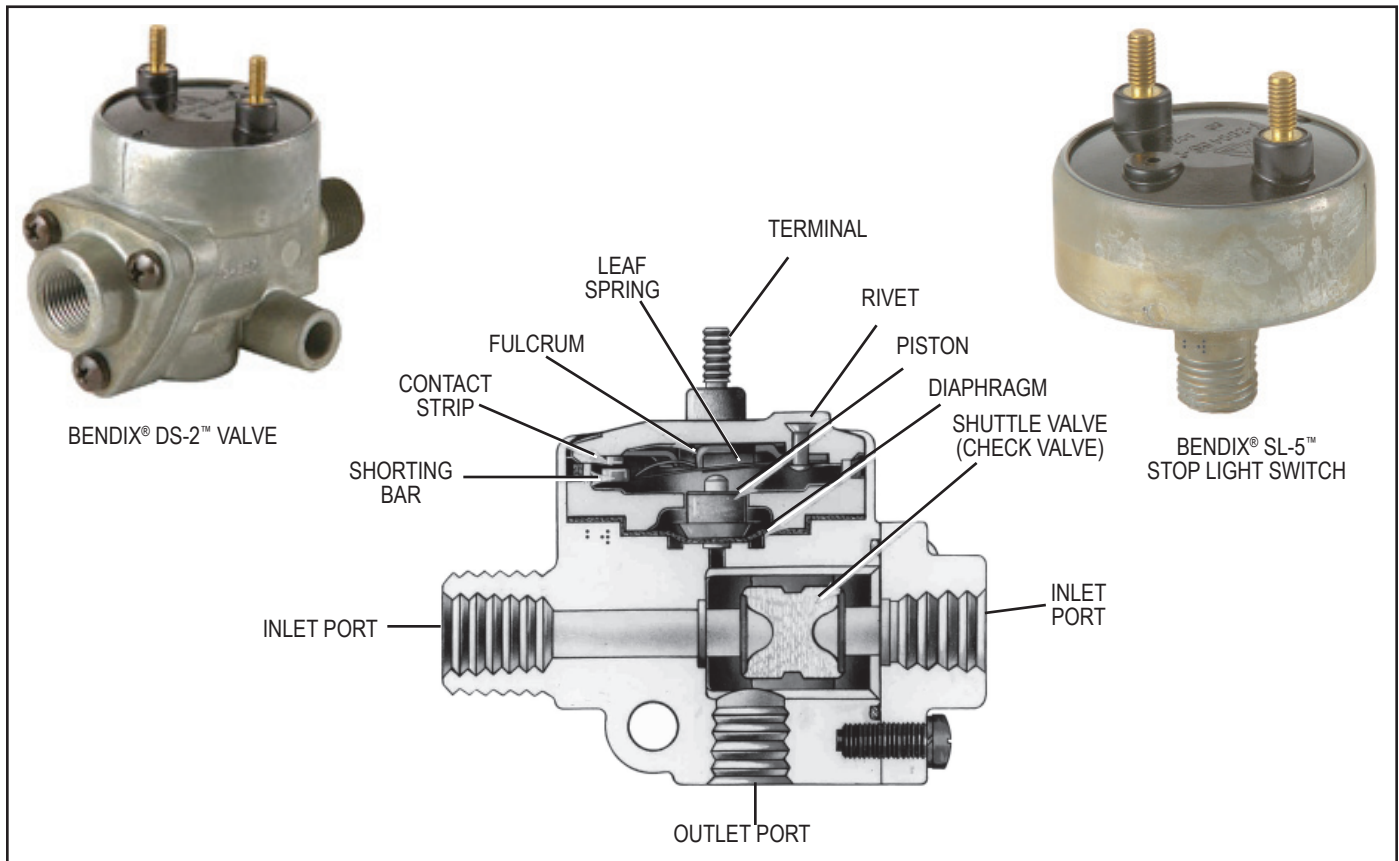

FIGURE 1 - BENDIX® DS-2™ COMBINED STOP LIGHT SWITCH & DOUBLE CHECK VALVE SECTIONAL

DESCRIPTION

The Bendix® SL-5™ stop light switch is an electro-pneumatic, 5 psi, non-grounded switch that operates in conjunction with the brake valve and stop lights. By completing the electrical circuit, the SL-5 switch illuminates the stop lights when a brake application is made.

The Bendix® DS-2™ combined stop light switch and double check valve—as the name implies—combines a Bendix SL-5 stop light switch with a Bendix® DC-4® double check valve to perform the function of both. It operates in conjunction with the brake valve and hand control valve by directing the flow of air, from whichever delivers the higher pressure, into a common delivery line and to the stop light switch, closing the electrical circuit to the stop lamps.

The stop light switch can be used with either 12 or 24 volt systems.

The stoplight switch is not a serviceable item. If found defective in either device, the complete unit must be replaced.

The shuttle valve in the DS-2 valve is serviceable and may be replaced.

Both the SL-5 switch and the DS-2 valve have been tested and meet the requirements of FMVSS 121.

OPERATION

The stop switch mechanism is identical in the SL-5 switch and the DS-2 valve.

When a brake application is made, air pressure from the brake valve enters the cavity below the diaphragm. The air pressure below the diaphragm moves the piston until it contacts the leaf spring. The leaf spring travels past a fulcrum at which point the leaf spring snaps a shorting bar

which mates with the contact strips. The stop light electrical circuit is completed, illuminating the stop lights before the brake application pressures reach 6 psi.

Note that the snap action spring design minimizes arcing.

The double check valve is activated by air being introduced through either of the two (2) inlet ports. The greater pressure pushes the shuttle along its guides and closes the opposite inlet port. The air is then directed out the common delivery line and to the stop light switch.

PREVENTIVE MAINTENANCE

Important: Review the Bendix Warranty Policy before performing any intrusive maintenance procedures. A warranty may be voided if intrusive maintenance is performed during the warranty period.

No two vehicles operate under identical conditions; as a result, maintenance intervals may vary. Experience is a valuable guide in determining the best maintenance interval for air brake system components. At a minimum, the Bendix® DS-2™/SL-5™ valve should be inspected every six (6) months or 1500 operating hours, whichever comes first, for proper operation and electrical connections. Should the DS-2/SL-5 valve not meet the elements of the operational tests noted in this document, further investigation and service of the valve may be required.

OPERATING AND LEAKAGE TEST

1. Install an accurate air gauge in the service line (or brake chamber). Apply the brake valve gradually. The stop lamps should light at 6 psi or less, and go out after the brake application is released. This checks the electrical function of the stop light switch in either the SL-5 switch or DS-2 valve.
2. DS-2 valve only – Apply the foot valve and coat the exhaust port of the hand valve (or other alternate source). Reverse the above, applying the hand valve or other alternate source, and coat the exhaust port of the foot valve. In either mode, leakage must not exceed 100 sccm or a 1” bubble in not less than five (5) seconds.
3. SL-5 switch or DS-2 valve – When pressurized, leakage must not exceed 20 sccm or a 1” bubble in not less than 10 seconds.

If the SL-5 switch or DS-2 valve does not function as described above, or if leakage is excessive, the valve or switch should be replaced with a new unit. In the case of the double check portion of the DS-2 valve, it must be repaired with genuine Bendix® service replacement parts.

REMOVING AND INSTALLING

REMOVING

1. Block the vehicle wheels or hold by means other than the vehicle service brakes.
2. Disconnect the electrical connections from terminal screws.
3. SL-5 switch – Remove the switch using a wrench on the hex portion of the body.
4. DS-2 valve – Disconnect the air lines and remove the DS-2 valve.

INSTALLING

1. Replace the SL-5 switch or DS-2 valve in the port from which it was removed. Do not install with the terminals pointing down.
2. Secure the electrical connections.
3. Reinstall the air line connections to DS-2 valve.

DISASSEMBLY (Double Check Valve)

1. Remove three cap screws and cap.
2. Remove the o-ring seal from cap.
3. Remove the shuttle valve.

CLEANING AND INSPECTION

1. Blow dust or other foreign material out of the body. Do not immerse in cleaning fluid.
2. Inspect the shuttle valve and o-rings for excessive wear or deterioration. Inspect the valve seats for nicks or burrs.

Replace all parts that were discarded, along with any parts not found to be serviceable during inspection, using only genuine Bendix replacement parts.

ASSEMBLY

Before assembling the DS-2 double check valve, lubricate all o-rings and o-ring grooves with Bendix silicone lubricant (Pc. No. 291126) or the equivalent.

NOTE: When using pipe thread sealant during assembly and installation, take particular care to prevent the sealant from entering the valve itself. Apply the sealant beginning with the second thread back from the end.

TEST

Repeat the “OPERATING AND LEAKAGE TEST” listed in this document.

GENERAL SAFETY GUIDELINES

WARNING!

PLEASE READ AND FOLLOW THESE INSTRUCTIONS TO AVOID PERSONAL INJURY OR DEATH:

When working on or around a vehicle, the following general precautions should be observed at all times.

1. Park the vehicle on a level surface, apply the parking brakes, and always block the wheels. Always wear safety glasses.
2. Stop the engine and remove ignition key when working under or around the vehicle. When working in the engine compartment, the engine should be shut off and the ignition key should be removed. Where circumstances require that the engine be in operation, **EXTREME CAUTION** should be used to prevent personal injury resulting from contact with moving, rotating, leaking, heated or electrically charged components.
3. Do not attempt to install, remove, disassemble or assemble a component until you have read and thoroughly understand the recommended procedures. Use only the proper tools and observe all precautions pertaining to use of those tools.
4. If the work is being performed on the vehicle's air brake system, or any auxiliary pressurized air systems, make certain to drain the air pressure from all reservoirs before beginning ANY work on the vehicle. If the vehicle is equipped with a Bendix® AD-IS® air dryer system or a dryer reservoir module, be sure to drain the purge reservoir.
5. Following the vehicle manufacturer's recommended procedures, deactivate the electrical system in a manner that safely removes all electrical power from the vehicle.
6. Never exceed manufacturer's recommended pressures.
7. Never connect or disconnect a hose or line containing pressure; it may whip. Never remove a component or plug unless you are certain all system pressure has been depleted.
8. Use only genuine Bendix® brand replacement parts, components and kits. Replacement hardware, tubing, hose, fittings, etc. must be of equivalent size, type and strength as original equipment and be designed specifically for such applications and systems.
9. Components with stripped threads or damaged parts should be replaced rather than repaired. Do not attempt repairs requiring machining or welding unless specifically stated and approved by the vehicle and component manufacturer.
10. Prior to returning the vehicle to service, make certain all components and systems are restored to their proper operating condition.
11. For vehicles with Automatic Traction Control (ATC), the ATC function must be disabled (ATC indicator lamp should be ON) prior to performing any vehicle maintenance where one or more wheels on a drive axle are lifted off the ground and moving.

