



**PARTS AND SERVICE INSTRUCTIONS FOR S84 STEER AXLE
WITH KNORR AIR DISC BRAKE
(OIL FILLED HUBS)**

ILLUSTRATION No.F68

MANUAL SECTION B



PARTS AND SERVICE INSTRUCTIONS FOR TYPE S84 STEER AXLE
DESCRIPTION

The axle is of 'Reverse Elliot' type comprising a girder section axle bed or beam with stub axles. Each stub axle is carried on a parallel king pin, with a steep angle taper roller bearing at its top and a plain phosphor bronze bush at bottom.

Hub taper roller bearings are of a generous size and, adjusted by means of special split nut with 'D' washer.

Brakes may be of Kirkstall or proprietary manufacture which can be serviced without disturbing the hub. Steering ball joints with hardened balls and rubbing pads incorporate compression springs which automatically take up any wear.

SECTION 1 ROUTINE MAINTENANCE

Note :- Manufacturers of crimped metal or nylon ring lock nuts recommend that they are replaced after being re-used one time.

1.1 Hub bearing adjustment

- a) An inspection should be made after first 3,000 miles (4,800 km) and then at intervals of 25,000 miles (40,000km). With wheels raised they should revolve quite freely without roughness.
- b) Hub bearings should have a slight end float movement within limits 0.0005" to 0.002" when oscillated backwards and forwards on axle stub. See section 10, page B11 if any adjustment is required.

1.2 To check front wheel ' Toe In '

- a) To preserve correct steering and avoid excessive tyre wear, tracking (or alignment) of the front wheels should be checked periodically, as follows :-
Set front wheels in straight ahead position and at points level with wheel centre, measure distance over wheel rims / hub flanges, both in front and behind axle centre.
For correct 'Toe In', front measurement 'B' should be 0" to $\frac{1}{32}$ " smaller than rear measurement 'A'. See fig.no.1.
- b) To allow for inaccuracies in wheels, the same check should be made with vehicle moved an equivalent to half of wheel revolution. Any adjustment required can be effected by slackening clamp bolts in ball sockets and rotating tie (track) rod tube.
After adjustment, tighten clamp bolts to 65 / 75 lbs. ft. (88 / 102Nm.) torque.

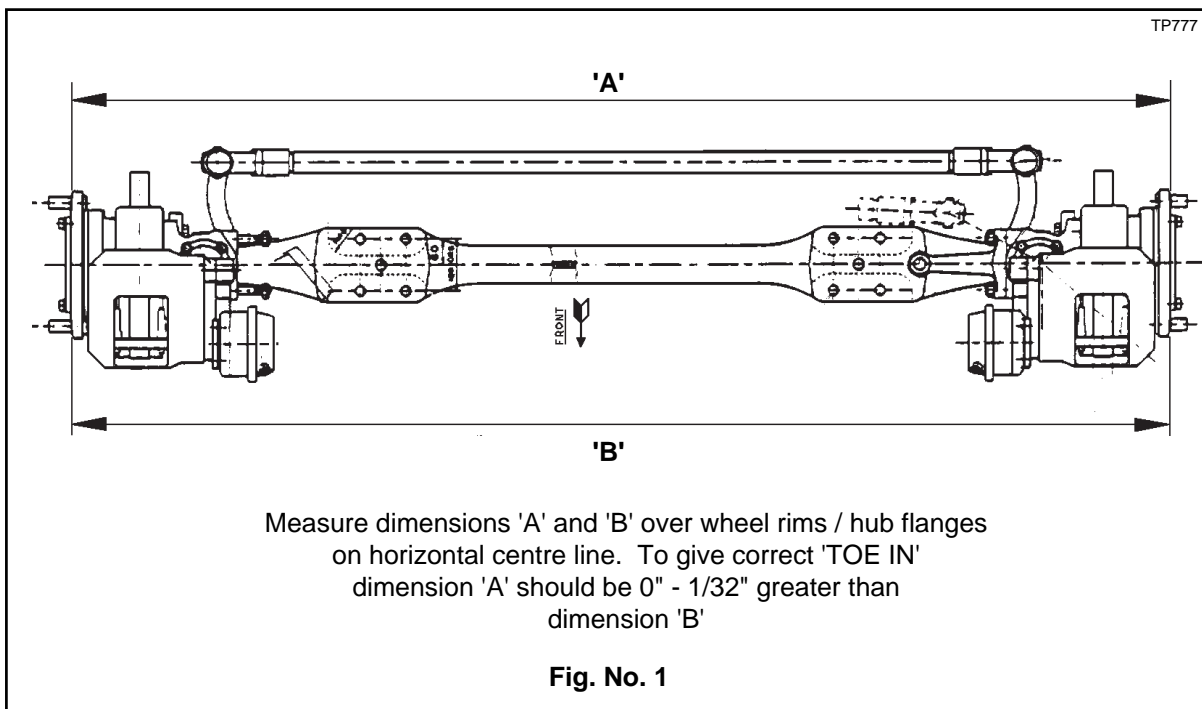

SECTION 1 ROUTINE MAINTENANCE Cont.

- 1.3 Check permissible slackness in swivel (king) pins every 25000 miles (40000 km) as follows :-
Aspects to be considered are :-

- a) Lateral slackness.
- b) Vertical slackness.

Before commencing checks, apply parking brake, raise wheels off the ground and support axle on stands.

a) **Checking lateral slackness**

Whilst this is being carried out the brake must be applied.

Place a set-square with its stock on ground and its blade against the tyre wall.

Place a mark on the ground to indicate position of stock end.

Insert a lever through bottom cut-out of wheel and lever it upwards thus moving set-square outboard.

Mark the changed position of the stock end.

Maximum allowable stock displacement (for 22.5" wheels) is **8mm**.

If displacement exceeds 8mm then the need for bush / bearing attention and possible renewal, is in evidence.

b) **Checking vertical slackness**

This is measured by a dial indicator anchored to the axle beam and having its pointer placed vertical against the swivel top.

Place a jack against the underside of the swivel and, whilst applying a lifting force, observe any movement on indicator dial.

If vertical movement is evident and it exceeds **0.030" (0.76mm)** then re-adjustment of swivel is required.

1.4 **VITON 'O' RINGS AND SEALS (FLOURO-ELASTOMERS) - SAFETY HAZARDS.**

It has been brought to our attention that 'Viton' material used in manufacture of oil seals and 'O' rings, produces a highly corrosive acid (hydroflouric) when subjected to temperatures above 315° C. The resulting contamination can have extreme consequences on human tissue since it is almost impossible to remove after contact.

We therefore recommend the following procedure when it is necessary to inspect any equipment that has been subjected to a high temperature i.e. fire.

- a) **Visually** inspect for any gaskets or seals which have suffered from heat ; they will appear black and sticky.
- b) If this is affirmed :- **Do Not Touch**.
- c) Make enquiries to ascertain material composition.
Any flouro-elastomer (Viton, Flourel or Tecmoflon) should be considered dangerous but natural rubber and nitrile are non-hazardous.
- d) If flouro-elastomer seals have been used, then the affected area **MUST** be decontaminated before undertaking further work.
- e) Disposable heavy duty gloves (neoprene) **MUST** be worn and the affected area decontaminated by washing thoroughly with limewater (calcium hydroxide solution).
- f) Any cloths, residue and gloves used **MUST** be safely discarded after use.

Note:- Burning of discarded items is NOT RECOMMENDED, except in an approved incineration process where gaseous products are treated by alkaline scrubbing.

1.5 **TOOLING / SEALING COMPOUND LIST**

Swivel pin dummy nut	SL225/15
Swivel pin oil seal bumper	E592
Loctite Superflex	
Loctite 638	
Loctite 405	
Loctite 7070 cleaning fluid	

SECTION 2 DRAINING THE OIL

- 2.1 Before attempting to remove road wheels, drive vehicle onto a level concrete floor, preferably after a short run to warm the oil.
- 2.2 Chock road wheels to be left on ground and apply parking brake.
- 2.3 Back off, but **do not remove** wheel nuts (7 pos.).
- 2.4 Raise vehicle and support on axle stands.
- 2.5 Remove wheel nuts (7) followed by road wheels.
- 2.6 Place a drip tray under hub unit, turn hub until drain plug in hub cap (74) is at B. D.C. then remove filler and drain plugs to drain oil.
- 2.7 When hub unit is completely drained of oil remove drip tray and dispose of old oil.

SECTION 3 TO REMOVE HUB UNIT

- 3.1 Disconnect air line from brake caliper (13).
- 3.2 Remove brake caliper setscrews with washers (16 & 15) then lift off brake caliper assembly (13).
- 3.3 Remove hub cap setscrews and washers (1 & 2).
- 3.4 Remove hub cap / adaptor assembly (3, 4, 74 to 76) from hub (8).
- 3.5 Remove and discard hub cap adaptor 'O' ring (4).
- 3.6 Remove hub cap setscrews with washers (76 & 75) then pull hub cap (74) from adaptor (3).
- 3.7 Remove hub bearing pinch bolt nut (5) and bolt (72), then remove hub bearing nut (73) along with hub bearing washer (6).
- 3.8 Pull hub / brake disc assembly (8 to 12, 69 to 71) from axle stub (65), place on clean bench and lift out outer bearing cone (70A).
- 3.9 Remove brake disc bolts (71) then pull brake disc (69) from hub (8).
- 3.10 Remove pole wheel (12) using suitable drift.
- 3.11 Remove seal (11) and inner bearing cone (10A) from hub (8).
- 3.12 Drive out hub bearing cups (10 & 70/70A) from hub (8).

SECTION 4 TO REMOVE THE STUB AXLE ASSEMBLY

- 4.1 Disconnect steering levers (31 & 54) from steering gear and tie rod & socket assembly (43 & 44).

Note :- When separating ball joint from steering lever, an extractor tool MUST be used. DO NOT strike areas around ball pin tapers with hammer blows under any circumstances due to possible ball pin taper deformation.

- 4.2 Remove swivel top cap setscrews and washers (25, 26 & 24, 27), enabling swivel top cap (23) to be removed.
- 4.3 Remove sealant from mating faces of top cap and swivel (23 & 65) using Loctite Chisel Gasket Remover or by carefully scraping from faces.
- 4.4 Remove bottom cap setscrews and washers (59 & 60).
- 4.5 Pull off swivel bottom cap and 'O' ring (61 & 62).
- 4.6 Remove swivel pin nut and washer (22 & 21).
- 4.7 Remove cotter pin nut (39) and washer (40), then tap out cotter pin (42) enabling swivel pin (63) to be driven out downwards, thus releasing it from axle bed (41).
- 4.8 The swivel assembly can now be removed from axle bed (41).
- 4.9 Take out swivel pin bearing (20 / 20A), swivel bearing adjustment shims (19), swivel bearing sleeve (17) and swivel bearing seal (18) from top of swivel (65).
- 4.10 Take out swivel 'V' ring seal (57) also sealing ring (58) from bottom of swivel (65).
- 4.11 Inspect swivel bottom bush (64) for wear / damage and knock out for replacement if required.
- 4.12 Remove top steering lever nuts (32) then pull off top steering lever (31) (if fitted). Care must be taken not to damage top steering lever studs (30).
- 4.13 Remove bottom lever nuts (47), then pull off bottom lever (54). Care must be taken not to damage bottom lever studs (55 & 56).
- 4.14 Check condition of swivel stop nut (35), and adjusting washers (34).

Inspection

Thoroughly clean all parts, inspect for wear and renew if required.

SECTION 5 DISMANTLING BALL SOCKET SEE FIG No 2.

- 5.1 Remove dirt seal (15) also dirt seal (pressing) (16) from ball pin.
- 5.2 Back off pinch bolt nut (10) then unscrew and remove ball socket assembly from tie rod having first marked ball socket body and tie rod to enable tracking on re-assembly.
- 5.4 Remove adjuster split pin (9) from ball socket body (3).
- 5.5 Remove cap (8) then using a suitable tool ie: a piece of 1 " x 1/8 " x 9 " flat bar, remove adjusting piece (7). Waggle ball (2) to free thrust cap (5).
- 5.6 Remove compression spring (6) also thrust cap (5) from ball socket body.
- 5.6 Relieve peening on socket body top (3) then using a hide faced mallet, tap ball pin (2) out of body.
- 5.7 Rubbing pad (4) can now be removed from body (3).

Thoroughly clean all parts and check for wear, renewing where necessary.

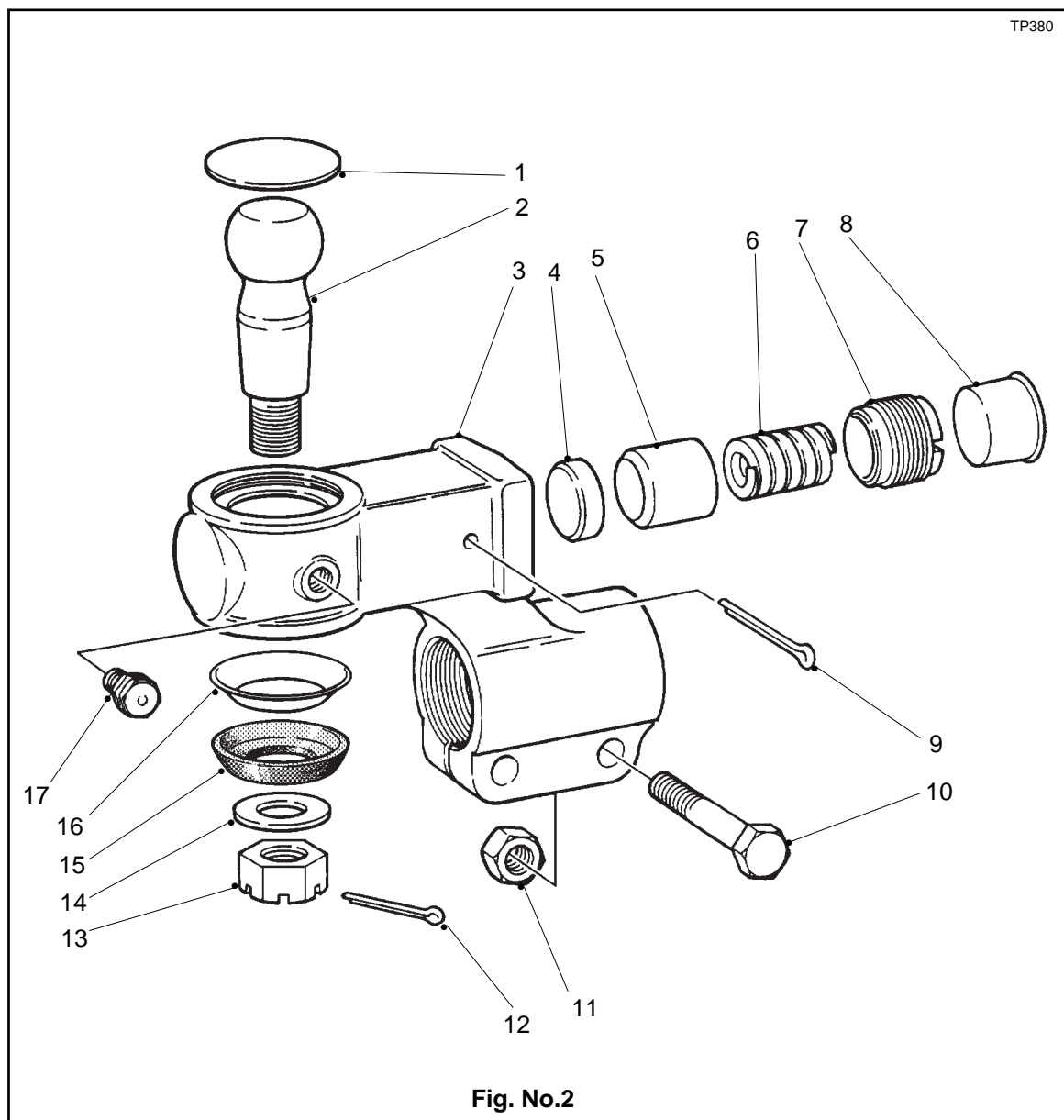

SECTION 6 ASSEMBLY OF BALL SOCKET AND TIE ROD Fig No 3.

Note :- Method of assembling ball socket is same for drop type shown and alternative straight body type.

- 6.1 Apply a bead of Loctite 638 sealant to mating corner of rubbing pad (4) in socket body (3) then knock rubbing pad (4) into its recess in ball socket body.
- 6.2 Thoroughly grease rubbing pad (4) and ball pin (2) with Shell 'Retinax LX' or equivalent.
- 6.3 Insert ball pin (2) into body.
- 6.4 Insert thrust cap (5), compression spring (6) and adjuster piece (7) into body.
- 6.5 Using a suitable tool ie: a 1" x 1/8" x 9" long flat bar, tighten adjuster piece (7) fully home (**SOLID**) locating thrust cup (5) onto ball pin (2).

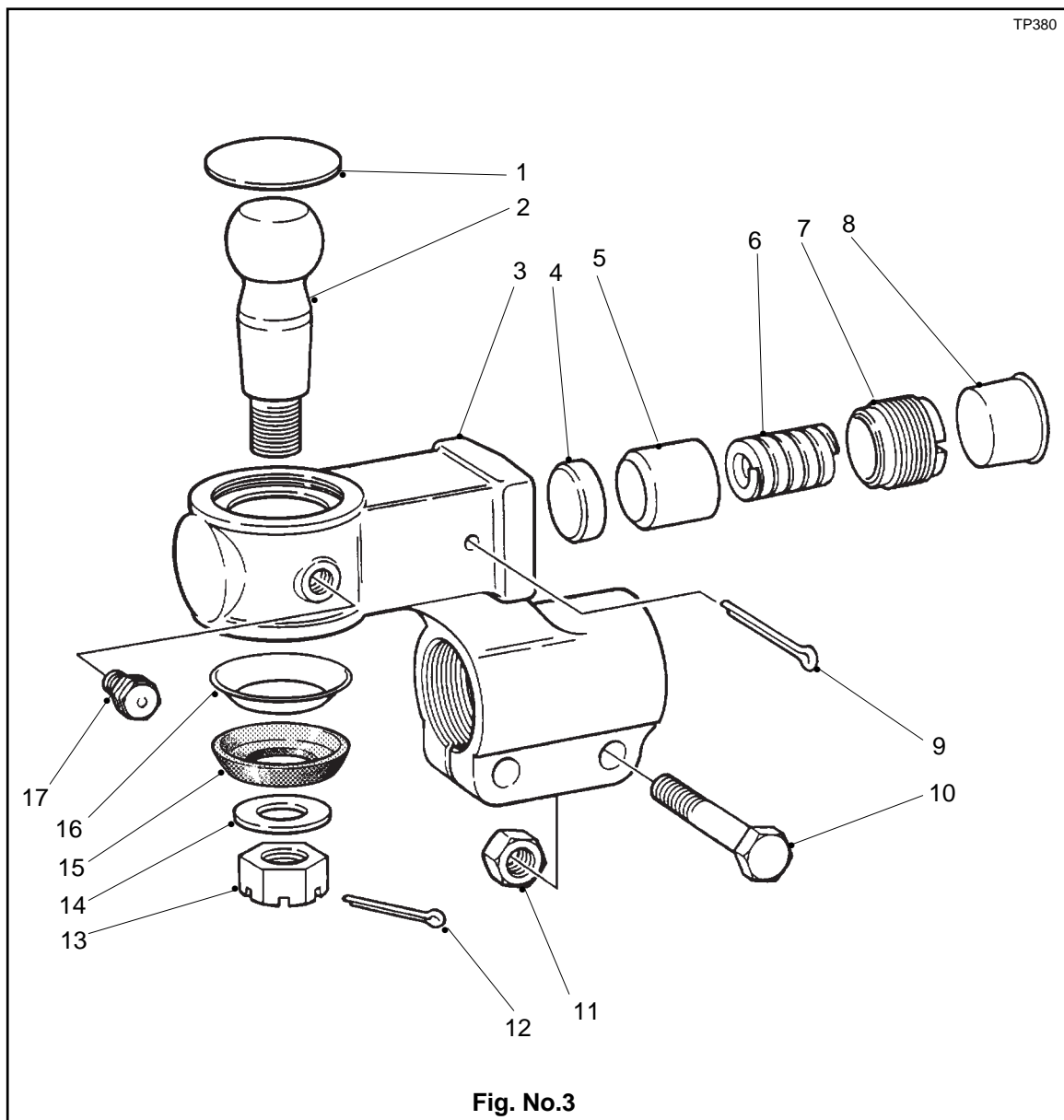

SECTION 6 ASSEMBLY OF BALL SOCKET AND TIE ROD Cont.

- 6.7 Still with tool located on adjuster piece (7), back off carefully (**LEAST AMOUNT**) until adjuster piece split pin (9) is allowed to pass through body, and that ball pin shank can be moved by force of hand, then remove tool.

Note :- If ball pin (2) does not rotate when re-adjusted in line with above instructions, this suggests that ball pin has local worn flats as shown in fig.no.4. In this instance ball pin (2), thrust cup (5) and rubbing pad (4) **MUST** be replaced, if not **FAILURE** could occur in service, ie ball pin (2) not being able to move in assembly when turning from lock to lock as shown in fig 5.

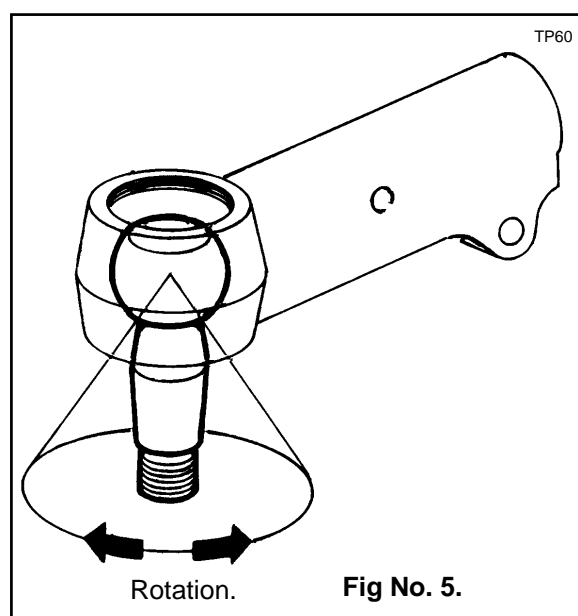
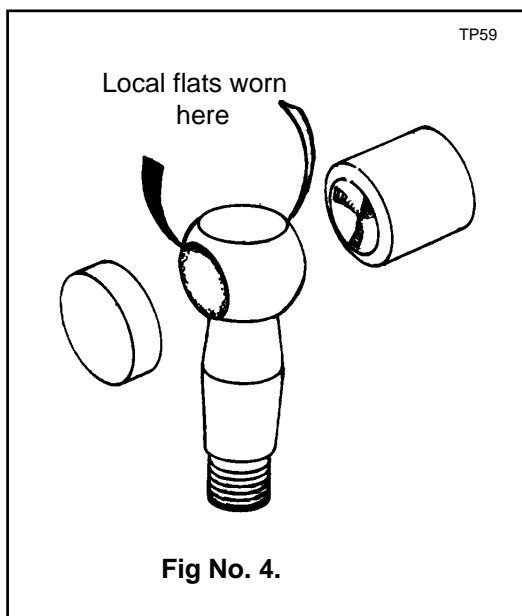

- 6.8 Fit cover plate (1) into top of ball socket body, re-peen using a cold chisel to secure.
- 6.9 Screw assembled ball socket onto tie rod. Lining up marks on both body and tie rod previously made, or retracting using manual Instructions.
- 6.10 Fit pinch bolts (10) and nuts (11) then tighten nuts (11) alternately and progressively to 65 / 75lbs.ft. (88 / 102Nm.) thus securing ball joint to tie rod.
- 6.11 Fit dirt seal (pressing) (16) and dirt seal (rubber) (15) onto ball pin (2).
- 6.12 Locate ball socket and tie rod assembly with steering lever, carefully align and fit ball pin (2) into hole in steering lever.

Note :- Ball pin (2) and ball pin tapers in bottom steering levers (49 - F68) must be clean, dry and free from oil prior to assembly.

- 6.13 Fit pin washer (14) onto ball pin (2).
- 6.15 Screw pin nut (13) onto ball pin (2) then tighten to 175 lbs. ft. (237Nm.) torque.
- 6.16 Using a 2lb hammer, tap steering lever to 'Shock' ball pin (2) into taper hole.
- 6.17 Re-torque pin nut (13) to 175 lbs. ft. (237Nm).
- 6.18 Fit split pin (12), if slot / hole are not in line, adjust up to next slot.

Min pin nut torque 175 lbs. ft. (237Nm.). Max pin nut torque 200 lbs. ft. (271Nm).

- 6.19 Re-charge ball socket with Shell 'Retinax LX' or equivalent grease through lubricator (17).

SECTION 7 REFITTING SWIVEL ASSEMBLY

- 7.1 Prior to assembly pack swivel pin bearing (20 / 20A) with lithium base grease (Shell 'Retinax LX' or equivalent) using a bearing packer or manually knead grease between rollers, race and cage.
- 7.2 Fit swivel pin top seal (18) open end first into position in top swivel bore (65) using tool no. E592 or similar.
- 7.3 Fit swivel pin bearing cup (20) into position in swivel bore (65).
- 7.4 Press swivel pin bottom bush (64) into position in swivel bore (65) until bush protrudes from swivel between 5.0 to 5.5mm. also ensuring that lubrication holes in swivel and bush line up when assembled together. See figure no.6.

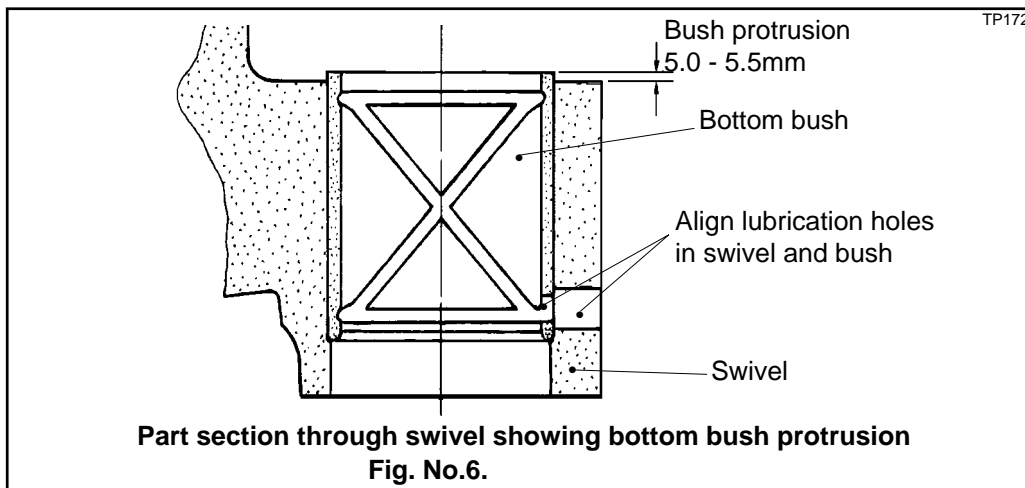

- 7.5 Apply a bead of 'Loctite no.405' all around protruding outside diameter of swivel pin bottom bush (64) then fit bottom 'V' ring seal (57) followed by sealing ring (58) into position abutting bush and swivel. (See fig.no.7.).

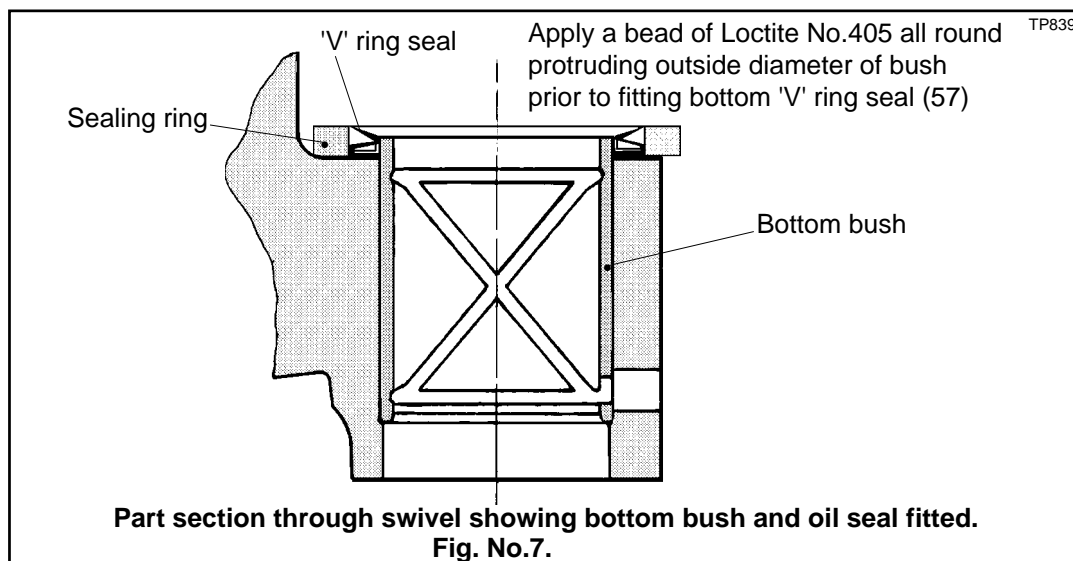

- 7.6 Position swivel assembly onto axle beam (41).
Note :- Care must be taken during this operation so as not to roll or trap swivel bush seal (57). Suggest a thin piece of card or plastic placed on seal during operation. Make sure that swivel pin bore is free of burrs and corrosion, then smear bore with lithium base grease (Shell Retinax LX or equivalent).
- 7.7 Push swivel pin (79) through swivel (30) and axle beam (56) ensuring that machined groove in swivel pin (63) is aligned with cotter pin hole, then fit cotter pin (42), washer (40) and nut (39).
Note :- Do not tighten nut (39) at this stage.
- 7.8 Place swivel bearing sleeve (17) down over swivel pin (63) and into position resting on top face of axle bed (41).
- 7.9 Select swivel bearing adjustment shims (19) with a total thickness of approximately 0.020 " and place in position on top of swivel bearing sleeve (17).
- 7.10 Fit swivel pin bearing cone (20A) to abut bearing cup (20).
- 7.11 Fit swivel pin washer (21) and dummy nut (use old nut with worn / ineffective locking portion) and tighten to 500 / 700 lbs.ft. (678 / 949Nm.).
Note :- If dummy nut is not available then use a slotted nut (SL225/15), tightening to 500lbs.ft. (678Nm.) max.
- 7.12 Using a 7/14 lbs. hammer, shock load axle beam (42) in swan neck area then re-check torque tightness of swivel pin nut (22).

SECTION 8 SWIVEL BEARING ADJUSTMENT

8.1 With nominal shim (19) thickness of 0.020 " placed between bearing (20 / 20A) and bearing sleeve (17), attach a cord and spring balance capable of reading 25 lbs (11 1/2 kg) to end of stub axle (65). See fig. no.8.

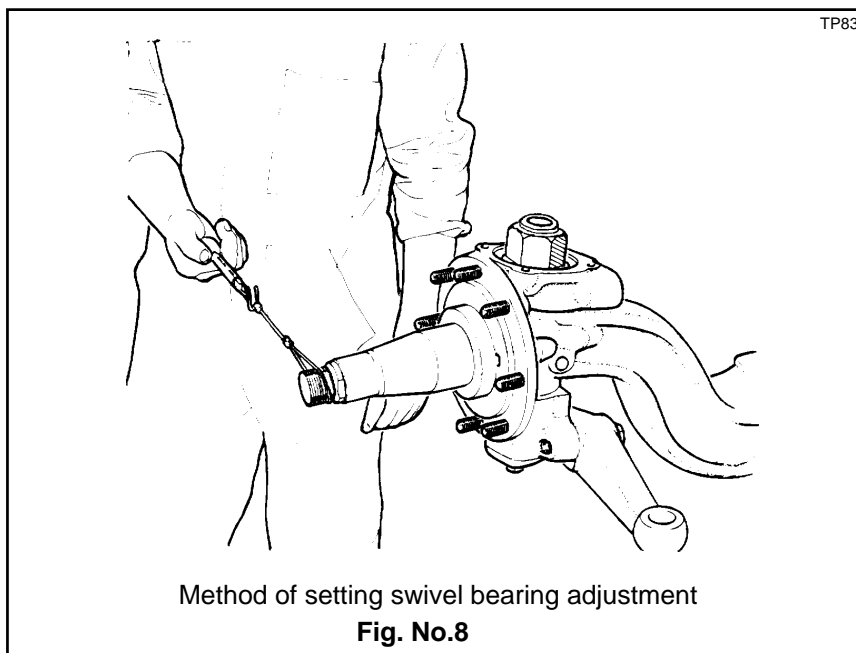

8.2 Pull swivel from lock to lock, noting spring balance reading, ignoring force needed to start movement. Correct reading should be between 12 to 24 lbs. (5 1/2 to 11kg.) pull, which equates to 10 to 20 lbs ft. (13.6 to 27Nm.) pre-load. If reading is outside these limits, it will be necessary to alter shim thickness (19) between bearing cone (20A) and its sleeve (17).

To increase load required, remove shims from nominal pack.

To decrease force required, add shims to nominal pack.

Add or subtract shims as required until a reading of 10 to 20 lbs. ft. (13.3 to 27Nm.) is obtained.

8.3 When swivel is set correctly, remove dummy / slotted nut and fit all metal stiff. nut (22) then tighten to 500 / 700 lbs ft. (678 / 949 Nm.) torque.

Note :- Manufacturers of crimped metal or nylon ring locknuts recommend that they are replaced after being re-used one time.

8.4 Tighten cotter pin nut (39) to 51 / 62 lbs.ft. (69 / 74Nm.).

8.5 Re-fit lock stops with adjusting washers (35 & 34) and set to dimensions shown in fig. no. 9.

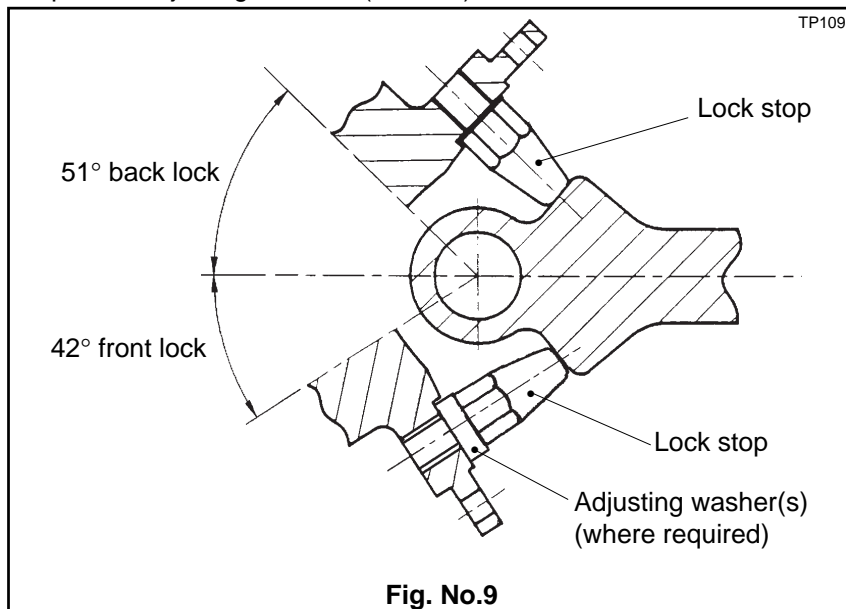

SECTION 9 SWIVEL FINAL ASSEMBLY

- 9.1 Apply a thin layer ($\frac{1}{16}$ " - 1.5mm) of lithium base grease (Shell 'Retinax LX' or equivalent) to inside of swivel top cap (23).
- 9.2 Clean mating faces of swivel and top cap (65 & 23) with Loctite 7070 or equivalent cleaning fluid then apply a 1/8" bead of Loctite Superflex (black) around base of top cap before fitting to swivel within 5 minutes of applying Loctite. See fig. no. 10.

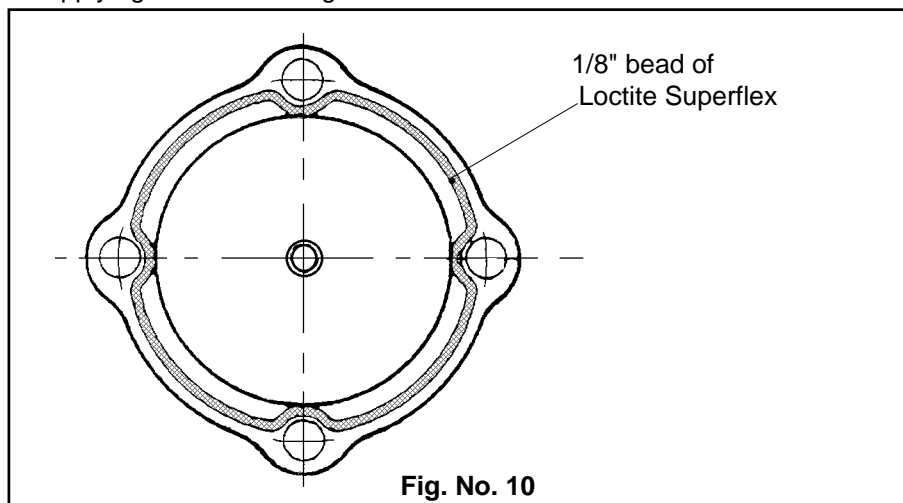

- 9.3 Place swivel top cap (23) in position on swivel (65).
- 9.4 Secure top cap (23) with swivel top cap setscrews and washers (25, 26 & 24, 27) and tighten to 51 / 62 lbs. ft. (69 / 74Nm.).
- 9.5 Place a new swivel bottom cap 'O' ring (62) in position on swivel bottom cap (61) and fit assembly into position on swivel (65).
- 9.6 Secure bottom cap (61) with swivel bottom cap setscrews and washers (59 & 60) then tighten to 26 / 32 lbs ft. (35 / 42Nm.).
- 9.7 Check tightness of bottom lever studs (55 & 56) is as shown in fitting procedure on page B14.
- 9.8 Fit bottom steering lever (54) onto studs (55 & 56).
- 9.9 Fit steering lever nuts (47) and tighten to 190 / 275 lbs. ft. (258 / 373Nm.).
- 9.10 Fit lubricator extension and lubricator (50 & 49) into position on bottom lever (54).
- 9.11 Secure nuts in position with lockwire as shown in fig. no.11.

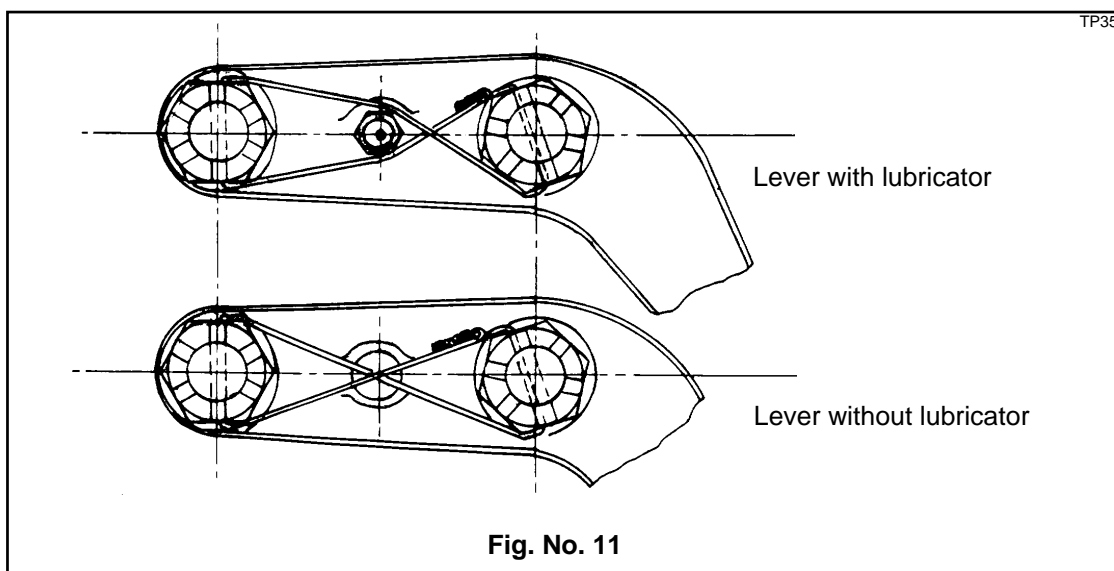

- 9.12 Check tightness of top lever studs (30) is as shown in fitting procedure on page B14.
- 9.13 Fit top steering lever (31), if fitted, onto studs (30) then fit nuts (32).
Tighten nuts to 190 / 275 lbs. ft. (258 / 373Nm.).
- 9.14 Fit new lubricator (28) into position in swivel top cap (23).

SECTION 9 SWIVEL FINAL ASSEMBLY Cont.

- 9.15 Charge swivel assembly with grease.
Swivel is full when grease seeps from between **upper face** of axle beam (41) and swivel jaw (65) in top half and from between swivel seal (18) and **lower face** of axle beam (see fig. no.12).

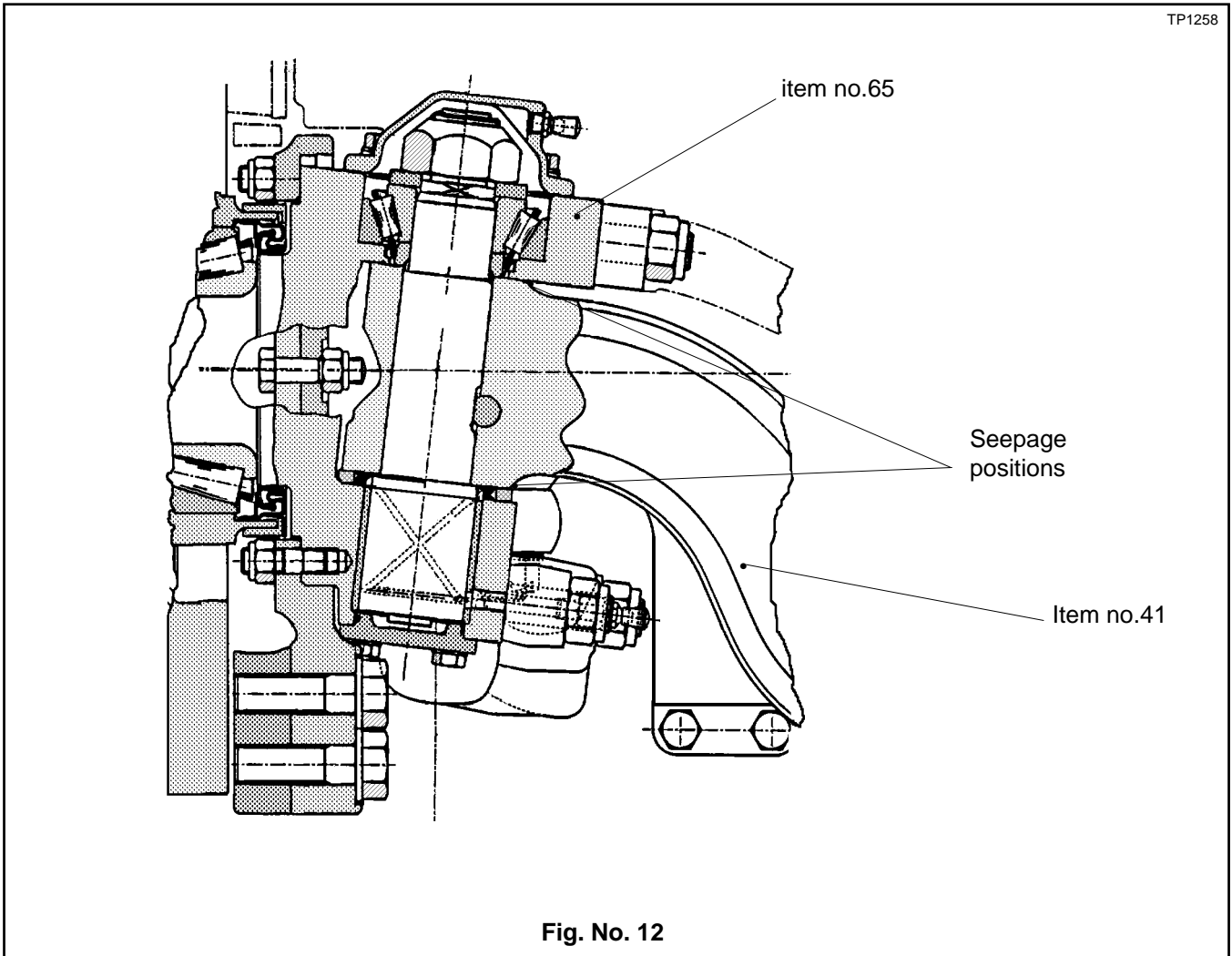

- 9.16 Reconnect ball socket and tie rod (44 & 43) to steering lever (54).

Note :- Ball pin (44) and ball pin tapers in bottom steering levers (54) must be clean, dry and free from oil prior to assembly.

SECTION 10 TO ASSEMBLE THE HUB

Prior to assembly, pack hub bearings (10/10A & 70/70A) with lithium base grease (Shell Retinax LX or equivalent) using a bearing packer or manually knead grease between rollers, race and cage.

- 10.1 Assemble brake disc (69) onto its position on hub (8) then secure with bolts (71), tightening to 222 / 246lbs.ft. (301 / 334Nm.).
- 10.2 Fit inner and outer hub bearing cups (10 & 70) onto their bores in hub (8).
- 10.3 Fit inner hub bearing cone (10A) into its cup in hub (8).
- 10.4 Press hub seal (11) into position in hub (8) using a suitable bumper tool which locates on outer part of seal to prevent damage on assembly.
- 10.5 Press pole wheel (12) fully into position on hub (8).
- 10.6 Fit hub assembly onto swivel stub axle (65).
- 10.7 Fit outer bearing cone (70A) into its cup (70).
- 10.8 Fit hub bearing washer and hub bearing nut (6 & 73). Tighten nut hard with the aid of a small tommy bar just enough to take up bearing slack.
- 10.9 Fit hub bearing nut pinch bolt and nut (72 & 5), tighten finger tight.
- 10.10 Adjust hub 'End Float' as follows :-
Rotate hub and using a hide faced mallet, knock hub backwards and forwards along axle arm to 'Shock Load' and thus settle bearings in position.

Note :- It is very important to rotate and ' shock load ' the hub because :-

- a) Rotation serves to ensure that bearing rollers settle into running in their correct tracks.
- b) ' Shock Load ' is to ensure that bearings are seated correctly up to their abutment shoulders.
Test tightness of hub bearing nut (73), if loose, re-tighten hard.
Rotate and ' Shock Load ' the hub again.
Continue this procedure until hub bearing nut (73) cannot be tightened further after hub has been rotated and ' Shock Loaded ' .
Back off hub bearing nut (73) by approximately 30° then rotate again and knock hub outward along axle arm to release bearings.
Mount a dial indicator on hub flange (8) and position its pointer on end of axle stub (65) (see fig. no. 13.).
Oscillate hub backwards and forwards along axle arm, taking a reading on dial indicator.
Correct ' End Float ' is between limits 0.0005 " to 0.002 " (0.013 to 0.050 mm).
Tighten hub bearing pinch bolt nut (5) to 26 / 32 lbs ft. (35 / 43Nm.).
Check ' End Float ' again, using above procedure, and adjust if outside specified limits.

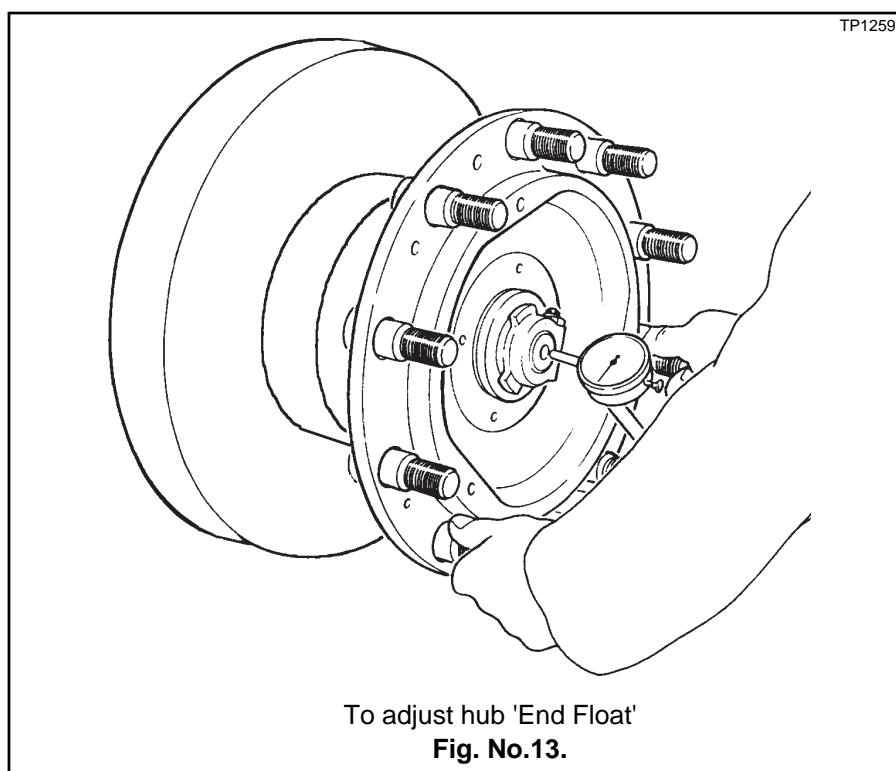

SECTION 10 TO ASSEMBLE THE HUB Cont.

- 10.11 Assemble hub cap (74) and adaptor (3) together then secure with washers and setscrews (75 & 76), tightening setscrews to 26 / 32lbs.ft. (35 / 43Nm.).
- 10.12 Smear 'O' ring (4) with clean grease then position on its register on hub cap adaptor (3).
- 10.13 Fit hub cap assembly, then secure with hub cap adaptor setscrews and washers (1 & 2) tightening setscrews to 65 / 71 lbs. ft. (88 / 96Nm.).

SECTION 11 FINAL ASSEMBLY

- 11.1 Position brake caliper unit (13) over brake disc (69) and secure with bolts and washers (16 & 15), tightening bolts to 433 / 479lbs.ft. (587 / 649Nm.).
- 11.2 Re-connect brake caliper to air system.
- 11.3 Refit road wheels, securing with wheel nuts (7 posn.).
Tighten nuts to 475 / 525 lbs. ft. (644 / 712 Nm).
- 11.4 Check axle supports then lower vehicle to ground.
- 11.5 Remove chocks and jacks.
- 11.6 Fill hub units with clean gear oil - see lubrication instructions at front of this manual, page A2.
- 11.7 Fit filler plug in hub cap (74).
- 11.8 Check wheel alignment as follows:-
Set wheels in a straight ahead position, and at points level with wheel centre, measure distance over wheel rims / hub flanges, both in front and behind axle centre.
For correct alignment, front measurements should be 0" to $\frac{1}{32}$ " smaller than that of rear
ie : 'Toe In' to allow for inaccuracies in the wheels, the same checks should be made with vehicle moved so that wheels have moved a further half a revolution (see fig. no.14).
Adjust if required by slackening ball joint clamp bolts and rotating track rod tube.

DO NOT forget to re-tighten the clamp bolts to 65 / 75lbs. ft. (88 / 102Nm.) after adjusting.

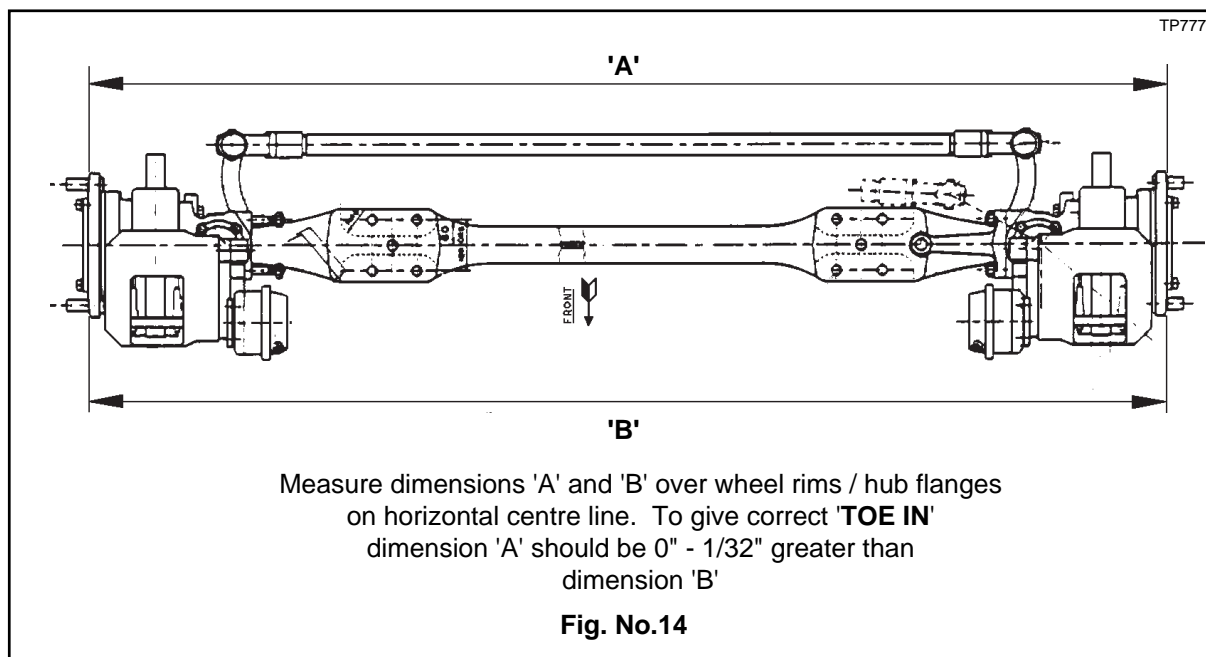

**TORQUE TABLE FOR S 84 STEER AXLE WITH KNORR AIR DISC BRAKE**

Item No	Description	Torque
1	Hub cap adaptor setscrew	65 / 71 lbs ft (88 / 96 Nm)
5	Hub pinch bolt nut	26 / 32 lbs ft (35 / 43 Nm)
7	Wheel nut	475 / 525 lbs. ft. (644 / 712 Nm)
16	Brake caliper setscrew	433 / 479lbs. ft. (587 / 649Nm.)
22	Swivel pin nut	500 / 700lbs.ft. (678 / 949Nm.)
25 & 26	Top cap setscrew	51 / 62 lbs. ft. (69 / 84 Nm)
32	Top lever nut	190 / 275 lbs. ft. (258 / 373 Nm)
33	Caliper bracket nut	85 / 103lbs.ft. (115 / 140Nm)
35	Stop nut	85 / 103lbs.ft. (115 / 140Nm)
44	Bottom lever nut	190 / 275 lbs ft (258 / 373 Nm)
49	Ball socket nut	100 / 170 lbs ft (136 / 231Nm)
55	Bottom cap setscrew	26 / 32 lbs ft (35 / 43 Nm)
63	Caliper bracket nut	85 / 103lbs.ft. (115 / 140Nm.)
66	Brake disc setscrew	222 / 246lbs.ft. (301 / 334Nm.)
71	Hub cap setscrews	26 / 32 lbs ft (35 / 43 Nm)

For stud fitting / setting procedures see page B14.



STANDARD STUDS - FITTED INTO MACHINED CHAMFERED HOLES

STUDS TO BE INSERTED UNTIL THREAD RUN-OUT LOCKS INTO PARENT METAL

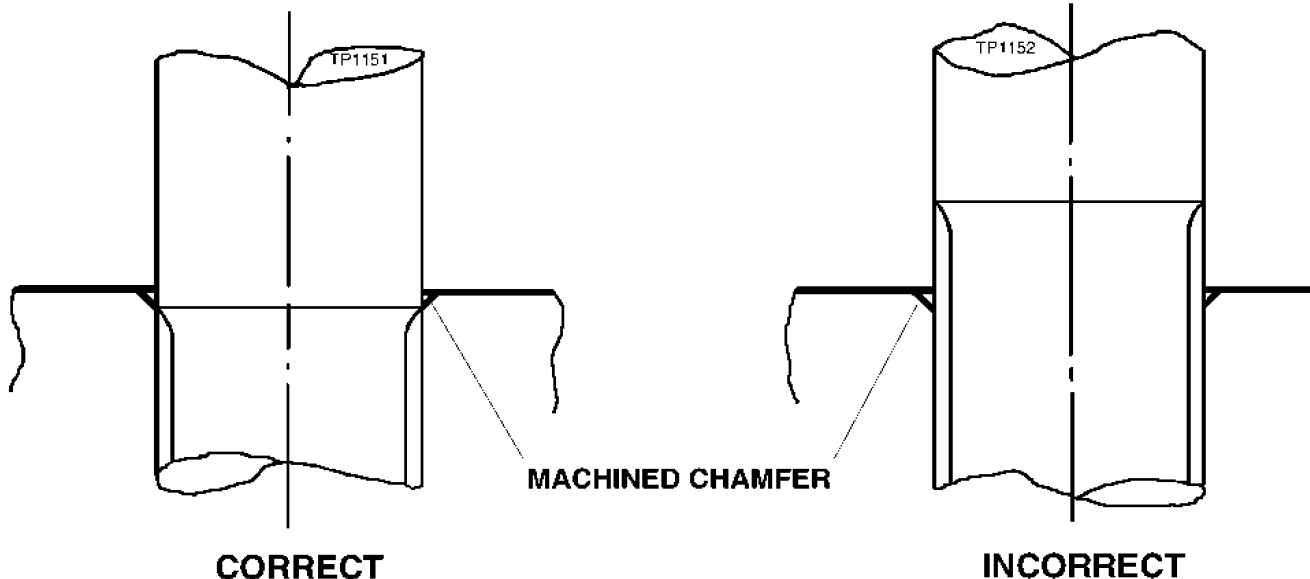

IMPORTANT :- THIS STUD FITTING PROCEDURE IS TO BE USED IN LIEU OF STATE TORQUE VALUES ON EXISTING ARRANGEMENTS.

NEW ARRANGEMENTS WILL SPECIFY TD183/1 FROM THE DATE OF ISSUE.

SPECIAL STUDS - FITTED INTO MACHINED PARALLEL COUNTERBORE

STUDS TO BE INSERTED UNTIL CORRECT TORQUE VALUE IS OBTAINED - AS SHOWN ON RELEVANT ARRANGEMENT DRAWING

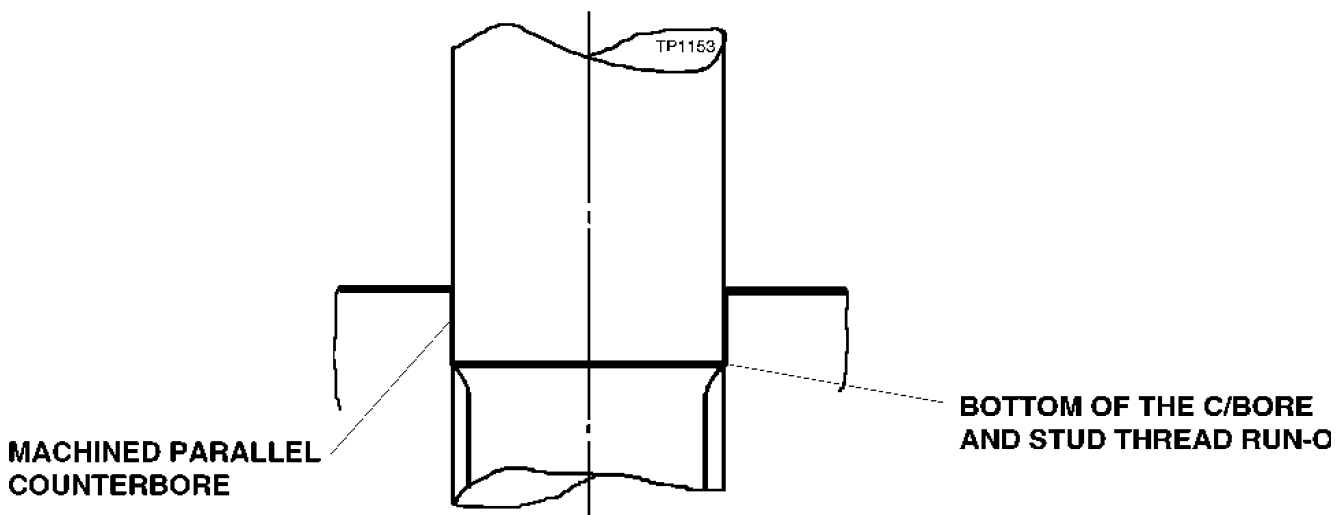

**THIS SPECIFICATION IS FOR STUD FITTING ONLY ;
NUTS & SETSCREWS MUST BE TORQUED TO VALUE SPECIFIED**

Alteration Numbers

ISSUE A								
---------	--	--	--	--	--	--	--	--

DISTRIBUTION	STUD FITTING	TD183/1
--------------	---------------------	----------------



PARTS LIST FOR S84 STEER AXLE (WITH KNORR DISC BRAKE)
CUSTOMER PREVOST **AXLE ASSEMBLY No.26551**

ILLUSTRATION No.F68

Item No	Description	Qty.Per Axle	Part No.	Recommended Spares Holding Per		
				25 Axles	50 Axles	100 Axles
1	Hub cap adaptor setscrew	10	ML6012/35S	10	10	20
2	Hub cap adaptor spring washer	10	ML5712/1	10	10	20
3	Hub cap adaptor	2	F4683/63	2	4	6
4	Hub cap 'O' ring	2	R9434/149	2	2	4
5	Bearing nut pinch nut	2	SL228/4	2	4	6
6	Hub bearing 'D' washer	2	7786/30	2	4	6
7	Wheel stud protective cover - not supplied by Kirkstall					
8	Hub	2	F4937/28	2	4	6
9	Wheel stud - not supplied by Kirkstall					
10	Hub Inner bearing cup	2	SL320/45	4	8	16
10A	Hub Inner bearing cone	2	SL320/46	4	8	16
11	Hub oil seal	2	R8585/187	4	8	16
12	Pole wheel	2	F4683/100	2	4	6
13	Brake caliper RH	1	SM486/14K	1	2	3
	Brake caliper LH	1	SM486/15K	1	2	3
14	Caliper mounting bracket RH	1	F4651/86	1	2	3
	Caliper mounting bracket LH	1	F4651/87	1	2	3
15	Brake caliper retaining washer	12	N70040	12	12	24
16	Brake caliper retaining bolt	12	N70251	12	12	24
17	Swivel pin bearing sleeve	2	F4477/19	2	4	6
18	Swivel pin oil seal	2	F4477/32	4	8	16
19	Adjusting shim (0.005")	min	4493/119	6	12	24
	Adjusting shim (0.010")	as	4493/119A	6	12	24
	Adjusting shim (0.015")	reqd	4493/119B	6	12	24
	Adjusting shim (0.008")	"	4493/119D	6	12	24
	Adjusting shim (0.006")	"	4493/119E	6	12	24
20	Swivel bearing cup	Kit no. 2	SL289/47	4	8	16
20A	Swivel bearing cone	17898/75	SL289/48	4	8	16
21	Swivel pin 'D' washer	2	7433/30	2	4	6
22	Swivel pin nut	2	F4477/15	2	4	6
23	Top cap	2	F4651/16	2	4	6
24	Top cap setscrew spring washer	6	SL241/5	6	6	12
25	Top cap setscrew	6	SL554/5	6	6	12
26	Top cap setscrew	2	F4651/40	2	2	4
27	Top cap setscrew spring washer	2	SL241/5	2	2	4
28	Lubricator	2	SL1000/1	2	2	4
29	Lubricator protective cap	2	SL1000/76	2	2	4
30	Top steering lever stud LH	2	SL778/11	2	2	4
	Top steering lever stud RH	2	SL778/21	2	2	4
31	Top lever (LH)	1	F4651/9	1	2	3
32	Top lever nut	4	SL222/9	4	4	8
33	Brake caliper bracket nut	6	SL228/6	6	6	12
34	Stop screw adjusting washer - as required		SL246/151 SL246/152 SL246/153			
35	Swivel stop screw LH	1	F4693/44B	1	2	3
	Swivel stop screw RH	2	F4693/44H	2	4	6
36	Supplied within item 65					
37 & 38	Not required on this application					
39	Cotter pin nut	2	SL221/5	2	2	4
40	Cotter pin washer	2	SL241/5	2	2	4
41	Axle bed	1	F4865/1	1	2	3
42	Cotter pin	2	F4722/57	2	4	6
43	Tie rod (assy with itm 44 - 25632/1)	1	F4560/12			



PARTS LIST FOR S84 STEER AXLE (WITH KNORR DISC BRAKE)
AXLE ASSEMBLY No.26551
ILLUSTRATION No.F68

Item No	Description	Qty.Per Axle	Part No.	Recommended Spares Holding Per		
				25 Axles	50 Axles	100 Axles
44	Socket assembly	1	25630			
	Socket assembly	1	25631			
45	Lubricator	2	SL1000/54	2	2	4
46	Lubricator protective cap	2	SL1000/76	2	2	4
47	Steering lever stud nut	4	SL222/9	4	4	8
48	Lubricator protective cap	2	SL1000/76	2	2	4
49	Lubricator	2	SL1000/7	2	2	4
50	Lubricator extension	2	SL1000/31	-	-	2
51 - 53	Supplied within item 44					
54	Bottom lever RH	1	F4651/7	1	2	3
	Bottom lever LH	1	F4651/8	1	2	3
55	Steering lever stud - (3 5/8" long)	2	SL778/18	2	2	4
56	Steering lever stud - (3" long)	2	SL778/13	2	2	4
57	Swivel pin seal ('V' ring)	2	LS1060/64A	6	12	24
58	Sealing ring	2	F4278/107	6	12	24
59	Bottom cap setscrew	4	SL553/4	4	4	8
60	Spring washer	4	SL242/4	4	4	8
61	Swivel bottom cap	2	F4477/34	2	4	6
62	Bottom cap 'O' ring	2	R3937/149	6	12	24
63	Swivel pin	2	F4477/14	2	4	6
64	Swivel pin bottom bush	2	F4477/20	2	4	6
65	Swivel assembly RH	1	SF4744/2	1	2	3
	Swivel assembly LH	1	SF4744/3	1	2	3
66	Brake caliper bracket stud	10	SL785/110	10	10	20
67	Brake caliper bracket bolt	6	SL795/68	6	6	12
68	Brake caliper bracket nut	10	SL228/6	10	10	20
69	Brake disc	2	F4683/88	2	4	6
70	Hub outer bearing cup	2	SL320/119	4	8	16
70A	Hub outer bearing cone	2	SL320/120	4	8	16
71	Brake disc bolt	20	ML7916/50V	20	20	40
72	Bearing nut pinch bolt	2	SL553/17	2	4	6
73	Hub bearing nut	2	7786/77A	2	4	6
74	Hub cap	2	F4744/29	2	4	6
74	Hub cap washer	12	ML5708/2	12	12	24
76	Hub cap setscrew	12	ML6008/16S	12	12	24



KIRKSTALL SPECIALITY AXLE DIVISION

Note :- 'Loctite Superflex Sealant' or an equivalent sealant to be applied to Cylinder Bracket / Top Cap clamp face before assembling to the Swivel.

TP822

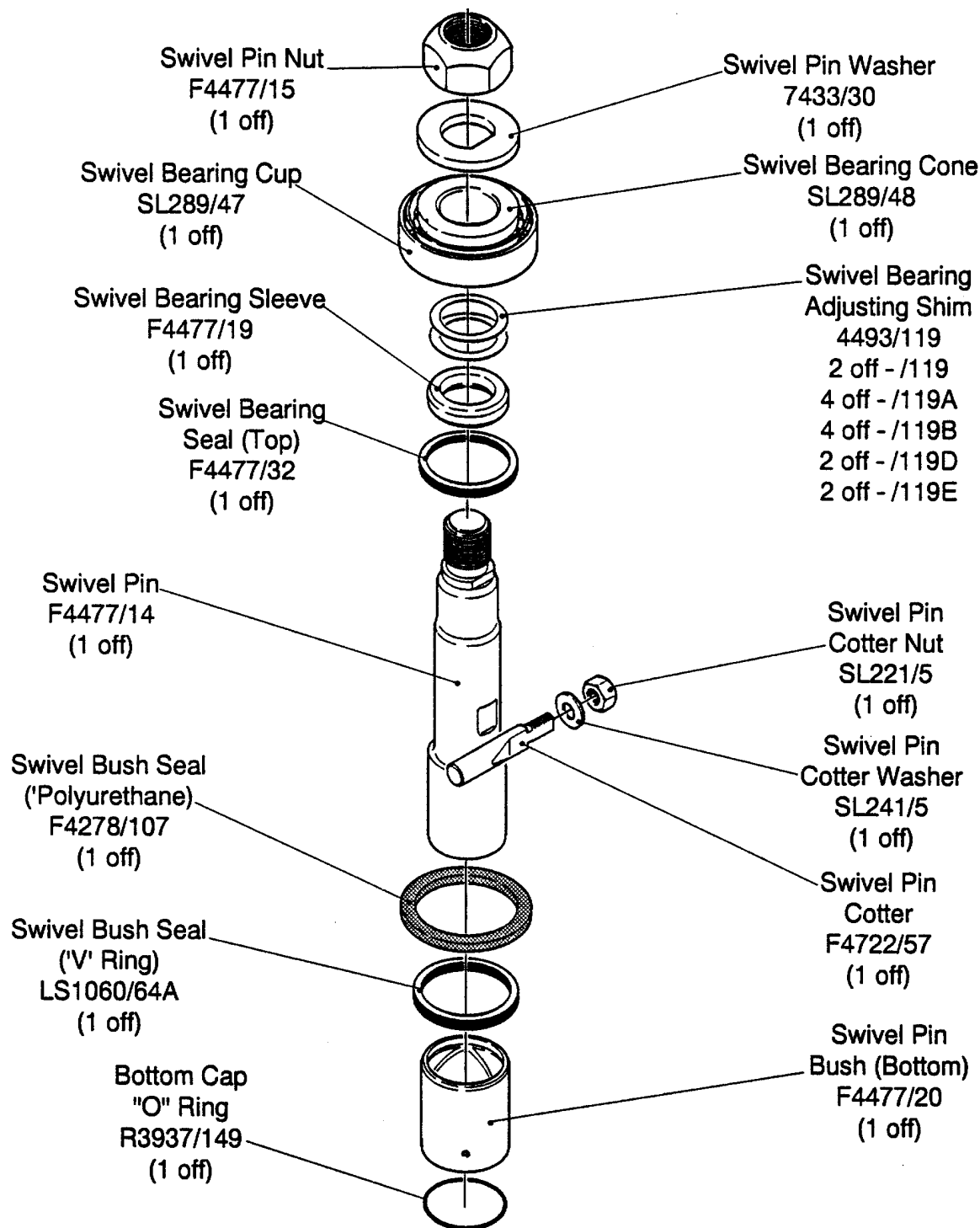

IMPORTANT :- It is recommended that a Dummy Nut is used to set the Swivel Bearing Pre-load, before fitting F4477/15. The Stiff Nut should only be removed & re-fit one time - after which, a new nut must be used.
Tightening Torque for Stiff Nut is 500 - 700lbs.ft. (678 - 949Nm.)

Alteration Numbers

Issue A	5168	5505	ECN6446			
---------	------	------	---------	--	--	--

Distribution :- Spares dept. Service	Swivel Pin Kit List No. 10280/1	Axle Type S75	Kit Arrgt. No 10280/1A
--	---	-------------------------	----------------------------------





KIRKSTALL SPECIALITY AXLE DIVISION

TP82

Note :- 'Loctite Superflex Sealant' or an equivalent sealant to be applied to Cylinder Bracket / Top Cap clamp face before assembling to the Swivel.

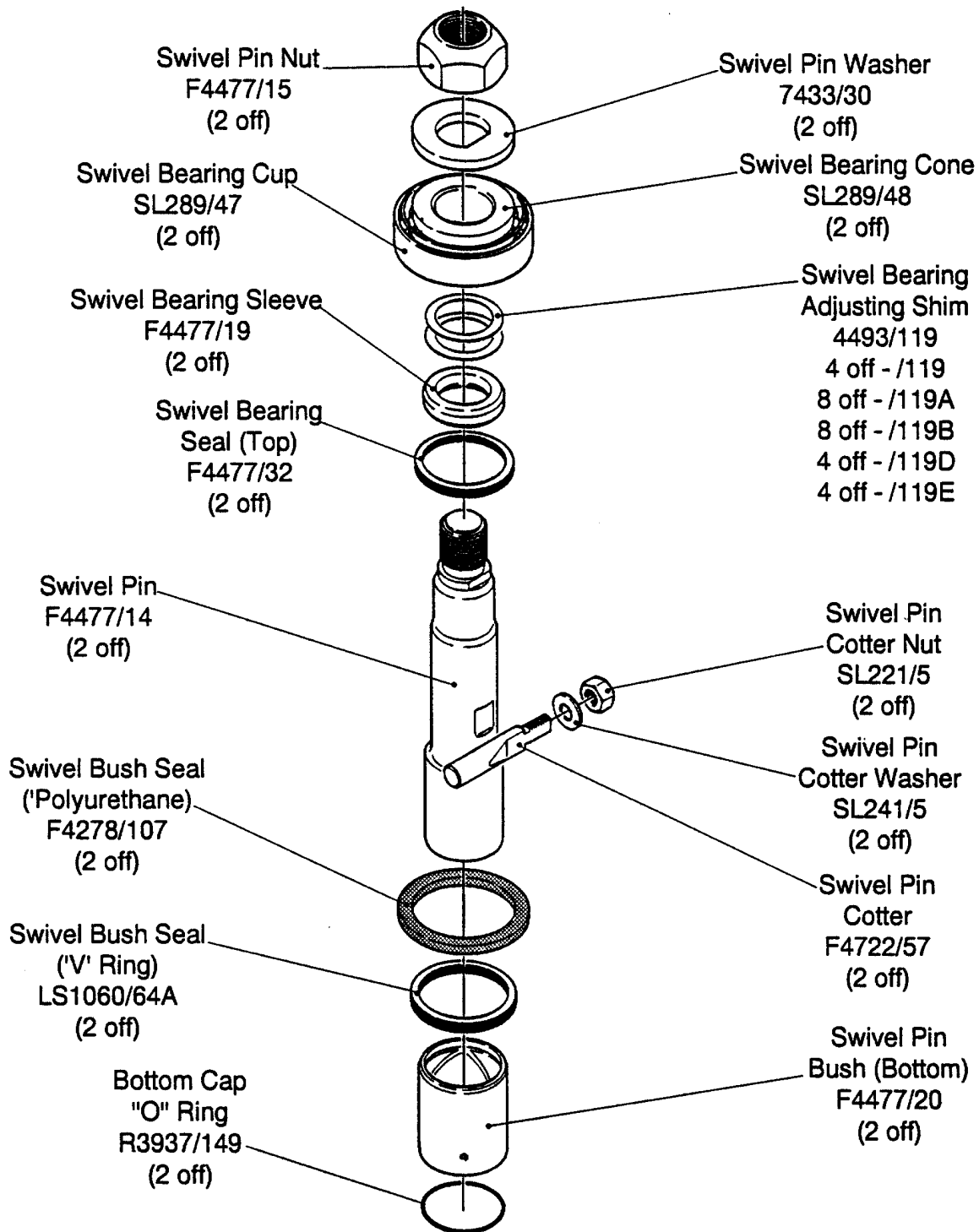

IMPORTANT :- It is recommended that a Dummy Nut is used to set the Swivel Bearing Pre-load, before fitting F4477/15. The Stiff Nut should only be removed & re-fit one time - after which, a new nut must be used. Tightening Torque for Stiff Nut is 500 - 700lbs.ft. (678 - 949Nm.)

Alteration Numbers

Issue A	5168	5505	ECN6446			
Distribution :- Spares dept.	Swivel Pin Kit		Axle Type	Kit Arrgt.		
	List No. 10280/0		S75	No. 10280/0A		





KIRKSTALL SPECIALITY AXLE DIVISION

Note :- 'Loctite Superflex Sealant' or an equivalent sealant to be applied to Cylinder Bracket / Top Cap clamp face before assembling to the Swivel.

TP1

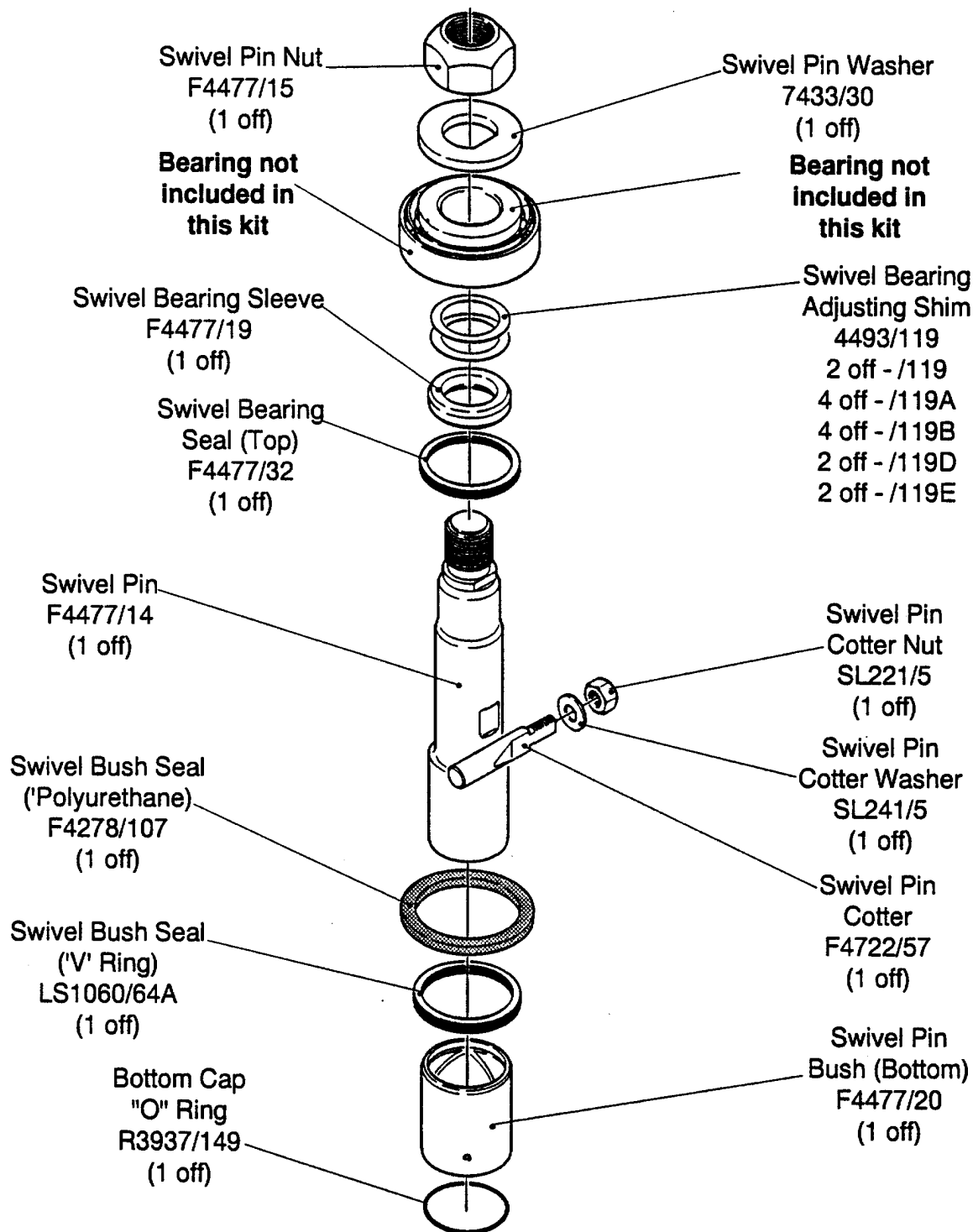

IMPORTANT :- It is recommended that a Dummy Nut is used to set the Swivel Bearing Pre-load, before fitting F4477/15. The Stiff Nut should only be removed & re-fit one time - after which, a new nut must be used. Tightening Torque for Stiff Nut is 500 - 700lbs.ft. (678 - 949Nm.)

Alteration Numbers

Issue A	5168	5505	ECN6446			
---------	------	------	---------	--	--	--

Distribution :- Spares dept. Service	Swivel Pin Kit List No 10280/3	Axle Type S75	Kit Arrgt. No 10280/3A
--	--	-------------------------	----------------------------------





KIRKSTALL SPECIALITY AXLE DIVISION

Note :- 'Loctite Superflex Sealant' or an equivalent sealant to be applied to Cylinder Bracket / Top Cap clamp face before assembling to the Swivel.

TP822

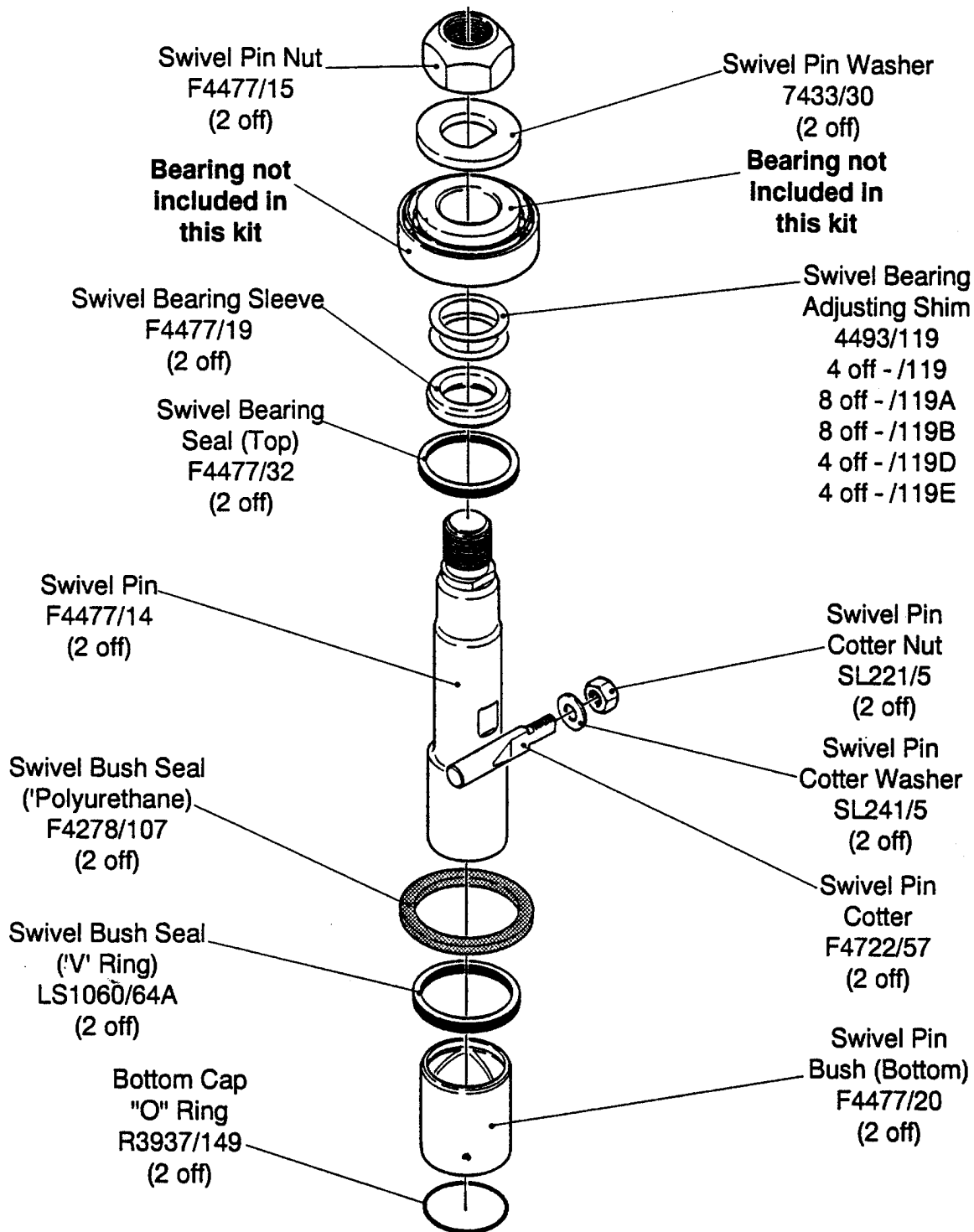

IMPORTANT :- It is recommended that a Dummy Nut is used to set the Swivel Bearing Pre-load, before fitting F4477/15. The Stiff Nut should only be removed & re-fit one time - after which, a new nut must be used. Tightening Torque for Stiff Nut is 500 - 700lbs.ft. (678 - 949Nm.)

Alteration Numbers

Issue A	5168	5505	ECN6446			
Distribution :- Spares dept.	Swivel Pin Kit List No. 10000/1		Axle Type 675	Kit Arrgt. No. 10000/1A		





Notes



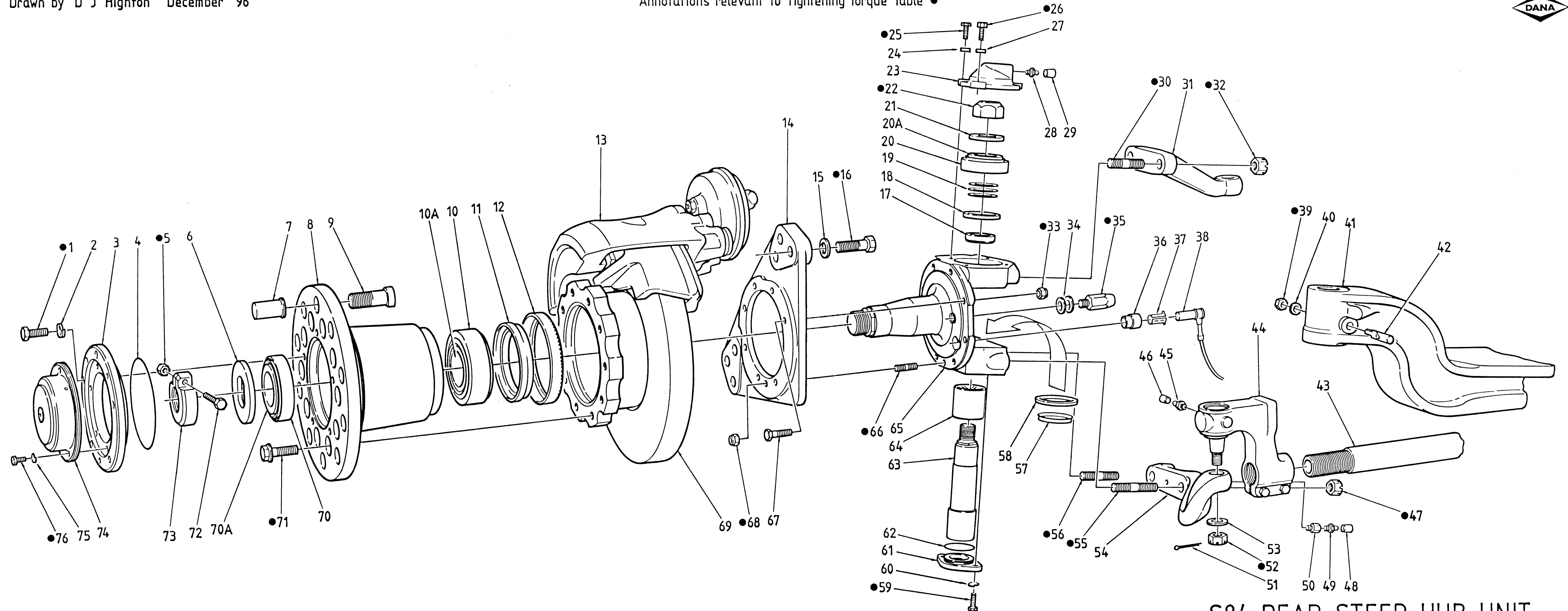

S84 DEAD STEER HUB UNIT
OIL FILLED