



### Threaded sleeve

Art.-Nr.: 21971 01

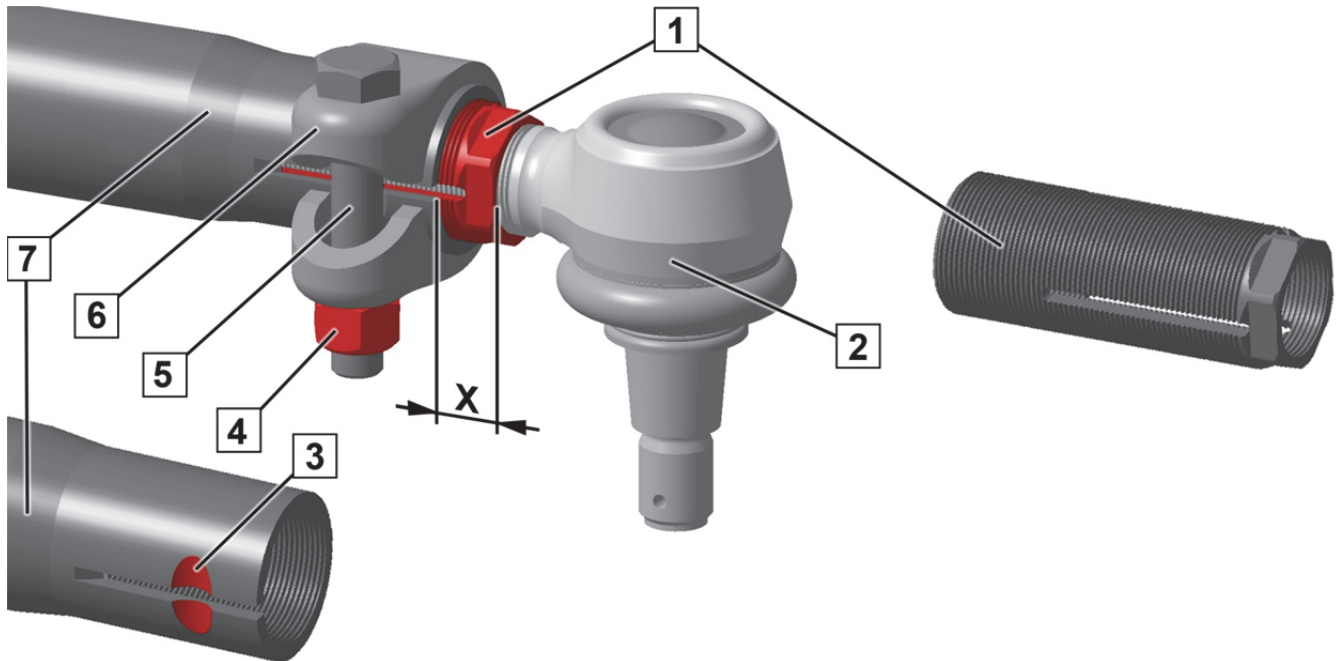

Fig. 1: Fine-tuning system

- |   |                   |   |       |
|---|-------------------|---|-------|
| 1 | Threaded sleeve   | 5 | Screw |
| 2 | Angle joint       | 6 | Clamp |
| 3 | Groove            | 7 | Tube  |
| 4 | Nut, self-locking |   |       |

### WARNING!



Too little pressure on the clamp (6) on the angle joint (2) can destroy the threaded sleeve (1).

The connection between the angle joint (2) and the threaded sleeve (1) can loosen. Heed information about the fine-tuning of the spur (page 2). The screw (5) may not touch the tube (7). Tighten the nut (4) to the prescribed tightening torque.

Do not use **any** screws with collar or **any** nuts with collar!

### NOTE



After adjusting the spur, the threaded sleeve (1) must protrude by the dimension **X** from the tube (7). Dimension **X** (Fig. 1):

- minimum 11 mm
- maximum 25 mm



### Adjusting the spur

1. Check screw (5):
  - If the screw (5) is bent or corroded: → replace screw (5).
2. Check clamp (6):
  - The wear pattern on the clamp (6) from the screw (5) and nut (4) must be even.
  - If the wear pattern on the clamp (6) is uneven: → replace clamp (6).
3. Check bearing surface of the clamp (6) on the tube (7).
4. Check threaded sleeve (1):
  - If the threaded sleeve (1) is damaged or corroded: → replace threaded sleeve (1).
5. Check angle joint (2):
  - If the angle joint (2) has axial play: → replace angle joint (2).
  - If the rubber boot on the angle joint is damaged: → replace angle joint (2).
  - If the threaded sleeves on the angle joint are corroded: → replace angle joint (2).
6. Adjusting the spur:
  - Heed dimension **X**.
7. Check fit of the clamp (6).
8. Position screw (5) in the groove (3). The screw (5) may **not** touch the tube (7).
9. Tighten new self-locking nuts (4) with the prescribed tightening torque.  
If the OEM does **not** prescribe tightening torque: 180 Nm.



<http://www.zf.com/serviceinformation>