

Electromagnetic compressor clutches

Service manual:

KK 73.1 / KK73.2, all types

1. Mounting the clutch on the compressor

The flange (6) and the shaft end (7) of the compressor must be free from dirt. Apply an high temperature approved assembly grease on the shaft end (7) for easy dismounting of the clutch.

Attention: We recommend the use of Molykote G-rapid-plus or Molykote P 40.

Slip the coil (1) on the retainer on the compressor flange. Fasten the coil with 4 screws (5) M8 to the compressor. Do not buckle the cable. When connecting the coil to the tension source, pay attention to the correct tension value (embossed at the cable entrance of the coil).

Attention: Pay attention to the precise seat of the coil. A non-observance may cause the destruction of the clutch components during operation.

Slip the rotor (2) carefully by hand on the shaft end (7) of the compressor till reaching the stop. The feather key (8) on the shaft end and the groove in the location hole of the rotor must be flush. Never use a hammer for pressing the rotor on.

Fasten the rotor to the shaft end by using a screw (3) M12 (SW 19), a straining washer (3a) and by holding-up with a wrench (SW 41) on the rotor.

Turn rotor by hand and pay attention to the free run and the generation of noises. In case of grinding or similar noises, dismount the clutch and check it.

2. Operation of clutch

The clutch does not need any maintenance during operation. During cleaning or other work on the compressor, the clutch must be covered to prevent the penetration of greasy liquids, grease or dirt particles in the working gap of the clutch. No high pressure cleaning.

3. Dismounting the clutch

Loosen and remove the straining screw (3) and hold it up on the rotor with a wrench (SW 41). Use a screw M16 as pulling-off screw and screw it in the straining washer (3a). Due to the back pressure the rotor (2) detaches from the shaft end (7) of the compressor. Loosen the fastening screws (5) of the coil und pull the coil (1) off the retainer (6).

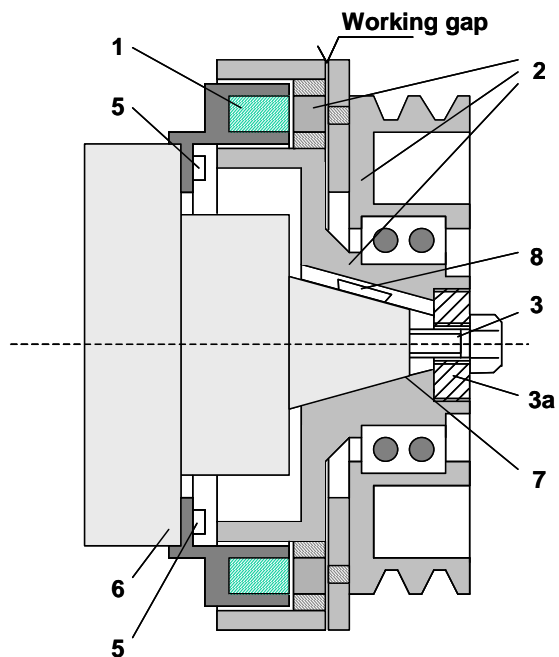

Attention: Do not apply any pulling-off or similar devices to the pulley. This will destroy the clutch components.

Electromagnetic compressor clutches

4. Specifications of clutch KK73.1

Appropriate compressors	FK(X)40, FK(X)50, FK(X)4, manufacturer: Bock 4UFCY, 4TFCY, 4PFCY, 4NFCY, manuf.: Bitzer KV4, KV5, KV6, manufacturer: Konvekta 4T-39 bis -65, manufacturer: Dorin
Admissible coolants for the air conditioning equipment	R12, R22 and R134a
Working voltage U of the coil:	12V/24V (see identification at the cable exit of the coil)
Current consumption I of the coil:	5,17A (12V) / 2,6A (24V) direct current at 20°C
Ohm resistance R of the coil:	2,3Ω (12V) / 9,2Ω (24V) at 20°C
Electric power P of the coil:	62W at 20°C
Protection class of coil:	IP64
Transferable torque M	450Nm at 20°C and 24V working voltage
Clutch operating voltage	20-28V (24V plant)
Guaranteed torque at 20V and 100°C	400Nm
Operation temperature	Max. +140°C
Distance between friction partners (working gap)	0.60 – 0.90mm
Property class of straining screw M12	8.8
Starting torque of straining screw	60Nm

Product in conformity with the following EC directions. Tested as per EN 50081-2 and EN 50082-2.
89/336 EEC direction

Electromagnetic compressor clutches

5. Trouble shooting, possible defects, elimination

Error	Cause	Elimination
Clutch does not close any more, no current stream	Intermittent contact in the plug	Check plug
	Contact corroded	Clean contact
	Connection cable defect	Repair cable, replace coil
Clutch does not close in spite of current stream	Short-circuit in the coil	Replace coil
	Insufficient voltage supply	Check supply from dynamo
Clutch slips when switched on (causes a destruction of the clutch by premature wear),	Impurities in the friction gap (foreign matters)	Disassemble clutch, remove foreign matters and assemble it again
	Insufficient voltage supply	Check supply from dynamo
	Friction surface polluted by small quantities of greasy or oleiferous substances	Disassemble clutch, clean friction surfaces with alcohol and assemble it again.
	Heat penetration in the clutch by slipping V-belts thus grease penetration in the bearing or overheating of the clutch	Disassemble clutch. Clean friction surfaces or replace already damaged components. After reassembly of the clutch, tension V-belts correctly
	Incorrect distance between coil and rotor (coil not in line with rotor), thus the switchable torque is reduced	Disassemble clutch, check cone for cleanness. Check the seat of the feather key, check the seat of the coil.
	Clutch worn, working gap to big (app. 1,2mm), friction partner blue	Replace clutch or component
Clutch does not open immediately when switched off, this will cause a premature wear of the clutch), shrieking noise	Voltage supply not completely interrupted	Check circuit element for switching the coil ON/OFF and replace it if necessary
Clutch does not open any more, voltage supply is in order	Clutch worn and friction partners welded to each other on the friction surface	Replace clutch
Permanent grinding noise	Coil not correctly centered or not firmly screwn down	Check coil, screw it down, or replace it if damaged. Check clutch for consequential damages, eventually disassemble clutch, check bearing and friction surfaces, replace eventually damaged components.
	Compressor bearings defect, causes friction between coil and rotor.	Replace bearings. Check coil function. Replace it if damaged. If clutch slips, replace whole clutch due to friction damage.

Electromagnetic compressor clutches

	Friction surface polluted by greasy or oleiferous substances	Disassemble the clutch, replace bearing, if necessary, clean friction surfaces with alcohol and assemble them again.
	Blockade of compressor. Clutch slips, both components blue due to friction heating.	Clutch destroyed, replace it.
Untrue run of the pulley, loud running noise	Bearing damaged due to wear or incorrect seat of the feather key	Check whether feather key and groove are flushing. If not, change clutch as the components will be permanently damaged, or disassemble the clutch and replace bearing.

6. Spare parts list

Description	Part number	DIN
Hexagon head screw	M12x40-8.8	933
Retaining ring for bores	90x3	472
Retaining ring for shafts	50x2	471
Button head socket screw	M8x8-10.9	ISO-7380
Cover disk	026.0005	
Bearing	022.0001	
Disk spring	020.0001	
Tension disk	KK73.007.0025	For wrench up to 3116A
Magnetic coil	KK73.005.0001	
Anchor disk	KK73.004.0005	
Rotor	KK73.003.0021	
Pulley	See declaration on the clutch	