

# **H5-60**

# **Maintenance**

# **Manual**

---

PREVOST CAR INC.  
Technical Publications  
After-Sales Service Department

Handwritten text, mostly illegible due to extreme fading and bleed-through from the reverse side of the page. Some faint words like "and" and "the" are visible.

Handwritten text, mostly illegible due to extreme fading and bleed-through from the reverse side of the page. Some faint words like "and" and "the" are visible.

Small handwritten mark or characters.

Small handwritten mark or characters.

Small handwritten mark or characters.

This manual contains operation, maintenance and overhaul information on Prévost H5-60 articulated vehicle models. Repair procedures and adjustments for major or special units are often included in additional manufacturer's booklets annexed to the corresponding section. Information in this manual pertains to standard and most commonly used optional equipments offered on these vehicles.

Vehicle operation from the driver's standpoint is contained in a separate operator's manual. For information on the diesel engine as well as on the automatic transmission, refer to the current *"Detroit Diesel Engines, Series 92 Service Manual"*, reference number 6SE380 and *"Allison Transmissions, HT, HTB 700 ATEC Series Service Manual"*, reference number SA2004. Troubleshooting manual for DDEC (Detroit Diesel Electronic Control) engines can be obtained from distributor under reference number 6SE477 (DDEC I) or 6SE489 (DDEC II), and troubleshooting manual for Allison transmission under reference number SA2048A.

A "full size" master of wiring diagrams is included in the technical publication box, supplied at vehicle delivery and an air line diagram is included in section 10 *"Brakes and Air System"*. Furthermore, a *"Lubrication and Service Check Points"* chart is annexed to section 19 *"Lubrication"* as a reminder.

Every effort has been made to include timely and adequate information on the various units and systems used on the articulated vehicles. The maintenance and repair procedures in the various sections are the result of extensive service experience. This information should serve not only as a reference for the experienced mechanical force, but also as a comprehensive text for training purposes.

In some cases, considerable space is devoted to describing the operation of a unit or system. The use of this space is justified by the presumption that in order for a mechanic to maintain a unit or system in a serviceable condition, he must first understand *"how the unit or system should function"*.

All information contained in this manual is based on the latest product information available at time of publication. Prévost reserves the right to make publication changes or add improvements at any time.

## IMPORTANT SAFETY NOTICE

Proper maintenance is important to the safe, reliable operation of all Prévost vehicles. The service procedures recommended and described in this manual are effective methods for performing service operations. In some instances, the use of special tools is recommended. These tools should be used when and as recommended.

It is important to note that this manual contains various **WARNINGS, CAUTIONS, AND NOTES** \* which should be carefully read in order to minimize the risk of personal injury or the possibility that improper service methods may be used which could damage the vehicle and render it unsafe. It is also important to understand that these warnings, cautions, and notes are not exhaustive. We could not evaluate and advise users of all conceivable ways in which service might be done or of the possible hazardous consequences of each way. Consequently, we have not attempted to do this. Accordingly, anyone who uses a service procedure or tool not recommended by the manufacturer must first convince himself that neither his safety nor vehicle safety will be jeopardized by the particular method he selects.

\* **WARNING:** Identifies instructions which if not followed, could result in personal injury.

**CAUTIONS:** Denotes instructions which if not followed, could cause serious damages to vehicle components.

**NOTE:** Indicates supplementary information needed to fully complete an instruction.

1942  
1943  
1944  
1945  
1946  
1947  
1948  
1949  
1950  
1951  
1952  
1953  
1954  
1955  
1956  
1957  
1958  
1959  
1960  
1961  
1962  
1963  
1964  
1965  
1966  
1967  
1968  
1969  
1970  
1971  
1972  
1973  
1974  
1975  
1976  
1977  
1978  
1979  
1980  
1981  
1982  
1983  
1984  
1985  
1986  
1987  
1988  
1989  
1990  
1991  
1992  
1993  
1994  
1995  
1996  
1997  
1998  
1999  
2000  
2001  
2002  
2003  
2004  
2005  
2006  
2007  
2008  
2009  
2010  
2011  
2012  
2013  
2014  
2015  
2016  
2017  
2018  
2019  
2020  
2021  
2022  
2023  
2024  
2025

1942  
1943  
1944  
1945  
1946  
1947  
1948  
1949  
1950  
1951  
1952  
1953  
1954  
1955  
1956  
1957  
1958  
1959  
1960  
1961  
1962  
1963  
1964  
1965  
1966  
1967  
1968  
1969  
1970  
1971  
1972  
1973  
1974  
1975  
1976  
1977  
1978  
1979  
1980  
1981  
1982  
1983  
1984  
1985  
1986  
1987  
1988  
1989  
1990  
1991  
1992  
1993  
1994  
1995  
1996  
1997  
1998  
1999  
2000  
2001  
2002  
2003  
2004  
2005  
2006  
2007  
2008  
2009  
2010  
2011  
2012  
2013  
2014  
2015  
2016  
2017  
2018  
2019  
2020  
2021  
2022  
2023  
2024  
2025

1942  
1943  
1944  
1945  
1946  
1947  
1948  
1949  
1950  
1951  
1952  
1953  
1954  
1955  
1956  
1957  
1958  
1959  
1960  
1961  
1962  
1963  
1964  
1965  
1966  
1967  
1968  
1969  
1970  
1971  
1972  
1973  
1974  
1975  
1976  
1977  
1978  
1979  
1980  
1981  
1982  
1983  
1984  
1985  
1986  
1987  
1988  
1989  
1990  
1991  
1992  
1993  
1994  
1995  
1996  
1997  
1998  
1999  
2000  
2001  
2002  
2003  
2004  
2005  
2006  
2007  
2008  
2009  
2010  
2011  
2012  
2013  
2014  
2015  
2016  
2017  
2018  
2019  
2020  
2021  
2022  
2023  
2024  
2025

1942  
1943  
1944  
1945  
1946  
1947  
1948  
1949  
1950  
1951  
1952  
1953  
1954  
1955  
1956  
1957  
1958  
1959  
1960  
1961  
1962  
1963  
1964  
1965  
1966  
1967  
1968  
1969  
1970  
1971  
1972  
1973  
1974  
1975  
1976  
1977  
1978  
1979  
1980  
1981  
1982  
1983  
1984  
1985  
1986  
1987  
1988  
1989  
1990  
1991  
1992  
1993  
1994  
1995  
1996  
1997  
1998  
1999  
2000  
2001  
2002  
2003  
2004  
2005  
2006  
2007  
2008  
2009  
2010  
2011  
2012  
2013  
2014  
2015  
2016  
2017  
2018  
2019  
2020  
2021  
2022  
2023  
2024  
2025

# GENERAL INFORMATION

---

## HOW TO USE THIS MANUAL

This manual is divided into major sections in the sequence shown on the table of contents. All major sections are divided into sub-sections containing descriptions, operation, maintenance, replacement, overhaul and specification informations on related systems and components. A numbered tab on the first page of each section separate each section according to the table of contents. Furthermore, a "*Contents of this section*" appears on the first page of each major section.

## PAGE AND ILLUSTRATION NUMBERS

Pages and illustrations are numbered consecutively within each major section.

## SPECIFICATIONS

Service data, torque limits and tolerances are listed at the end of most sections under the heading "*Specifications*". Manufacturer's model or part numbers are provided where applicable for component identification. All detail service part numbers must be obtained from the "*Prévost H5-60 Parts Manual*".

## SERVICE BULLETINS AND SERVICE INFORMATION LETTERS

Service Bulletins and Service Information Letters are issued from time to time to acquaint users with the latest service procedures, to supplement or to supersede information in this manual. Information in the Service Bulletins and Service Information Letters should be noted in the text, and the Service Bulletins and Service Information Letters annexed to the corresponding section for future reference.

## SERVICE TOOLS

A service tool and equipment list is annexed to each section. These tools are specially designed to accomplish certain operations efficiently and readily. Such tools are identified in the text by the vendor's tool number. These tools are not offered for sale by Prévost and should be ordered from the supplier.

## ALPHABETICAL INDEX

Important subjects, with the manual section and page number reference, are alphabetically listed in section 20 "*Index*".

## SERIAL NUMBER LOCATIONS

Delay and confusion can be avoided when correct vehicle identification number (VIN), engine and transmission serial numbers are written on parts orders and correspondence. Locations of these serial numbers can be found in the "*Operator's Manual*" under heading "*Data plate and attestation*" in the Technical Description section.

Handwritten notes at the top of the page, including a date and some illegible text.

Handwritten notes in the middle section, possibly a list or a set of instructions.

Handwritten notes at the bottom of the page, including a date and some illegible text.

# TECHNICAL DATA

The data below includes only general information on Prévost H5-60 articulated vehicles. For specific data and specifications refer to headings "Specifications" annexed to each section. Furthermore, a light bulb data is annexed to the section 15 (Electrical system) and a list of lubricant is given on the "Lubrication Chart and Servicing Check Points" annexed to section 19 (Lubrication) under heading "Recommended lubricant code".

## DIMENSIONS AND WEIGHTS

Overall length (over bumpers)	60'0" (18 288 mm)
Overall height (over closed roof hatches)	12'0" (3 568 mm)
Overall width (max.)	102" (2 590 mm)
Wheelbase (center of first steering axle to center of tandem drive axles)	23'11" (7 290 mm)
Overhang, front	72" (1 829 mm)
Overhang, rear	69" (1 753 mm)
Track, front (Axles 1 & 2)	85,7" (2 176 mm)
Track, drive (Axles 3 & 4)	83" (2 107 mm)
Track, rear (Axle 5)	85,7" (2 176 mm)
Turning circle diameter (exterior front corner)	42'0" (12 802 mm)
Front section length	34' 5" (10 490 mm)
Accordion length	4' 4" (1 321 mm)
Rear section length	21' 3" (6 477 mm)
Floor height from ground	63" (1 600 mm)
Headroom	77" (1 956 mm)
Aisle width	14" (355 mm)
Seating	71 passengers (w/full recliners and two card tables in rear section) 76 passengers (w/semi-recliners) 48 passengers (w/full recliners) 2/1 layout
Interior storage compartments	140 cu. ft (4 m <sup>3</sup> )
Underfloor baggage compartments	546 cu. ft (15,5 m <sup>3</sup> )
Vehicle curb weight (dry)	45,900 lbs (20 820 kg)
G.V.W.R.*	59,840 lbs (27 143 kg)
G.A.W.R.*	
Axle 1 & 2, front	13,000 lbs (5 900 kg)
Axle 3 & 4, drive	14,000 lbs (6 360 kg)
Axle 5, rear	13,000 lbs (5 900 kg)

# TECHNICAL DATA (CONT.)

## Tire size (Recommended)

Firestone	315/80 R 22.5
Goodyear	12.75 R 22.5
Michelin	XZA12 R 22.5 or 315/80 R 22.5
Yokohama	12 R 22.5

\* The vehicle curb weight, the Gross Vehicle Weight Rating (G.V.W.R.), and the Gross Axle Weight Ratings (G.A.W.R.) for front, drive and rear axles, are listed on certification plate located behind driver's seat.

The gross vehicle weight rating includes the weight of the basic vehicle plus full fuel tank, oil and coolant, plus maximum load with combines passenger (150 pounds/68 kg per designated seating position) and the baggage weight (3 pounds/ cu.ft, 48 kg/m<sup>3</sup>).

The gross axle weight rating is the maximum load that can be applied on each axle of the vehicle.

## CAPACITIES

### LIQUID

Windshield washer reservoir	.5 U.S. gal/ 19 liters
Lavatory sump tank	30 U.S. gal/ 114 liters
Lavatory fresh water tank	24 U.S. gal/90 liters
Cooling system (includes heating system)	58 U.S. gal/ 220 liters

### OIL

#### Engine crankcase

Crankcase	25 U.S. qts (24 liters)
Oil filter	2 U.S. qts (2 liters)
Engine oil cooler	1,5 U.S. qts (1,4 liters)
Engine oil reserve tank	2,5 U.S. gal/ 9,45 liters

#### Automatic transmission and retarder

System fill (after overhaul)	38 U.S. qts/ 36 liters
Refill (after drain)	33 U.S. qts/ 31 liters

#### Hydraulic system (for power steering and condenser motor)

Tank only	6,5 U.S. gal/ 24,6 liters
Tank and hoses	10 U.S. gal/ 38 liters
A/C compressor (crankcase)	1,13 U.S. gal/ 4,3 liters

### Differential

Forward/rear differential	.40 pints/ 19 liters
Rear/rear differential	.37 pints/ 17.5 liters



# TECHNICAL DATA (CONT.)

---

## FUEL

Total capacity . . . . . 200 U.S. gal/ 757 liters  
Large tank . . . . . 125 U.S. gal/ 473 liters  
Small tank . . . . . 75 U.S. gal/ 284 liters

## REFRIGERANT

Freon type 22 . . . . . 44 lbs/ 20 kg



# FREQUENTLY SERVICED PARTS

DESCRIPTION	SUPPLIER NUMBER	PREVOST NUMBER
<b><u>OIL FILTERS</u></b>		
Engine oil filter (AC Spark Plug)	25013192 model PF-911L	51-0373
Transmission oil filter (AC Spark Plug)	25010643 model HD-223	57-1457
Hydraulic oil filter (Vickers)	573082	66-0671
Forward/rear differential oil filter (Fram)	model PH-30	62-1323
<b><u>FUEL FILTERS</u></b>		
Fuel filter/water separator element cartridge (Racor)	20205M-OR	53-0194
Secondary fuel filter (AC Spark Plug)	25010778 model TP-916	51-0128
Preheater fuel filter (Fram)	C-1110-PB	87-0894
<b><u>COOLANT FILTER</u></b>		
Coolant filter (Perry filter)	PFC-24A	55-0276
<b><u>AIR CLEANER</u></b>		
Air filter element cartridge (Nelson)	70337-N	53-0197
HVAC unit air filters (Carrier)	38-00143-00	87-0951
<b><u>BELTS</u></b>		
Hydraulic pump (Gates)	9N1145 model V80 3V450	50-6317
A/C compressor (Gates)	CX85 model V80 (288D)	50-6600
Fan transfer (Gates)	CX75 model V80 (358D)	50-6601



# PARTS SERVICE

---

For customer's satisfaction, Prévost Car Inc. has a part distribution center in Canada for Canadian customers, as well as U.S. centers for American customers. Each distribution center listed below can supply you with genuine H5-60 parts.

## U.S.A.

### **Central States**

Expar Inc.  
124 Joe Drive  
Elk Grove Village, Illinois 60007  
Phone Number: (312) 640-1877  
Toll free: (800) 621-5519

### **Western States**

Prévost Car Inc.  
22831 Frampton Avenue  
Torrance, California 90501  
Phone Number: (213) 325-6643

### **Eastern States**

Prévost Car Inc.  
862 Valley Brook Avenue  
P.O. Box 268  
Lyndhurst, New Jersey 07071  
Phone Number: (201) 933-3900  
Toll free: (800) 223-0807 New Jersey  
(800) 223-0830 Out of state

Prévost Car Inc.  
7451 Wilson Boulevard  
Jacksonville, Florida 32210  
Phone Number: (904) 778-4499  
Toll free: (800) 322-2057 Florida  
(800) 874-7740 Out of state

## CANADA

Prévost Car Inc.  
35, boul. Gagnon  
Sainte-Claire, Québec  
Canada, G0R 2V0  
Phone Numbers: Day (418) 883-3391 Ext: 239  
After 5 p.m. (418) 883-2276  
Toll free: (800) 463-8876



# TABLE OF CONTENTS

---

ENGINE . . . . .	01
FUEL SYSTEM . . . . .	02
COOLING SYSTEM . . . . .	03
EXHAUST SYSTEM . . . . .	04
TRANSMISSION . . . . .	05
PROPELLER SHAFTS . . . . .	06
FRONT AXLES (1 & 2) . . . . .	07
DRIVE AXLES (3 & 4) . . . . .	08
REAR AXLE (5) . . . . .	09
BRAKES AND AIR SYSTEM . . . . .	10
WHEELS, HUBS AND TIRES . . . . .	11
STEERING . . . . .	12
ARTICULATION . . . . .	13
SUSPENSION . . . . .	14
ELECTRICAL SYSTEM . . . . .	15
HEATING AND AIR CONDITIONING . . . . .	16
BODY . . . . .	17
ACCESSORIES . . . . .	18
LUBRICATION . . . . .	19
INDEX . . . . .	20

---





# 01

# ENGINE

## CONTENTS OF THIS SECTION

DESCRIPTION . . . . .	1-1
POWER PLANT ASSEMBLY REMOVAL . . . . .	1-1
ENGINE REMOVAL AND INSTALLATION . . . . .	1-5
POWER PLANT ASSEMBLY INSTALLATION . . . . .	1-7
ENGINE MOUNTS . . . . .	1-7



## DESCRIPTION

This vehicle is powered by a 8 V-92, two-cycle Detroit Diesel engine, provided with an electronic control system (DDEC I or II). Maintenance and repair information on the engine will be found in the current engine manufacturer's maintenance manual. Engine controls, accessories and related components are covered in the applicable sections of this maintenance manual. For more information about the electronic control system, refer to the troubleshooting guide # 6SE477 published by Detroit Diesel for engine equipped with DDEC I, and # 6SE489 for engine equipped with DDEC II.

## POWER PLANT ASSEMBLY REMOVAL

The vehicle power plant assembly must be removed as a whole unit by means of a slide-out cradle on the L.H. side of vehicle, thus providing access to the engine or related components. The power plant assembly includes the following items:

- Engine
- Air intake system
- Exhaust system
- Transmission assembly including retarder
- Radiator and fan drive
- Preheating unit
- Transmission oil cooler
- Air compressor
- Alternator
- Engine oil reserve tank

Follow the procedure hereafter to remove the power plant assembly.

**CAUTION:** All hoses and cables must be properly identified prior to their disconnection, to facilitate their reinstallation. Plug all openings to prevent dirt from entering the system.

1. Set the battery main disconnect switches to the "Off" position.
2. Drain the engine cooling system as explained in section 03 - "Cooling system" under heading "Draining cooling system".
3. Drain the hydraulic fluid tank by removing the drain plugs located in L.H. side rear fender of front section.
4. Remove tension on A/C compressor belts by means of the belt tensioner two-way control valve, located in the engine compartment (refer to the "Operator's Manual" for more details).

5. From inside the first baggage compartment, remove the six (6) retaining screws of the engine front access panel, then the access panel.

6. Remove both V belts from A/C compressor.

7. Exhaust air from the air system according to the procedure given in section 10 - "Brakes & air system".

**CAUTION:** During the next step, the first L.H. side baggage compartment door must remain closed in order to provide additional clearance when opening the condenser door.

8. Open the condenser door to its maximum position, push the retaining bar upwards in order to free its locking mechanism, then open further condenser door and block in position (see fig. 1).

**CAUTION:** Take care not to damage the first baggage compartment door, since the receiver pipes can interfere with the lower section of the baggage compartment door.

9. Disconnect the hydraulic supply hose from the condenser motor, then unscrew the fasteners on retaining clips in order to separate the hoses (see fig. 1).

10. Unscrew the four (4) retaining bolts of the radiator panel, then remove the panel (see fig. 2).

11. Unbolt both brackets securing the radiator panel to the side wall.

12. Remove the fasteners holding the central post adjacent to the radiator (see fig. 2).

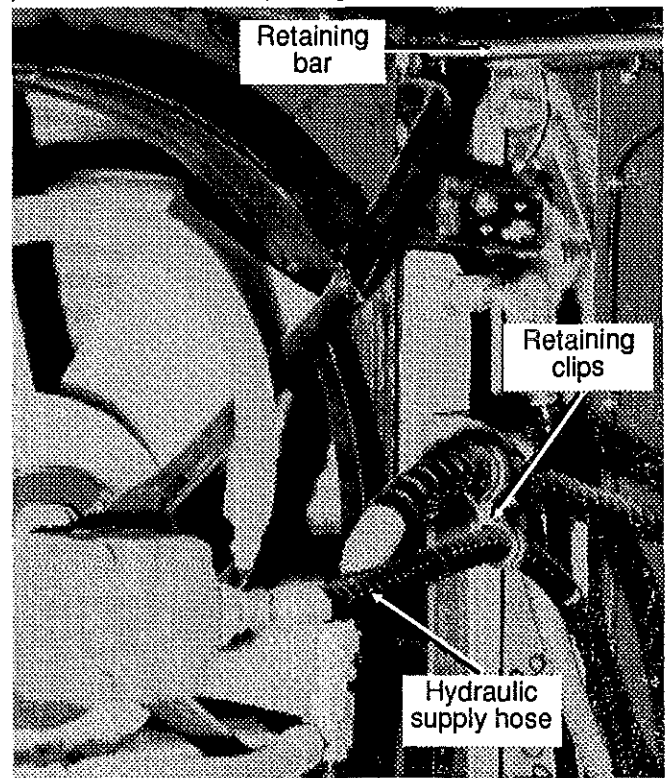

FIG. 1

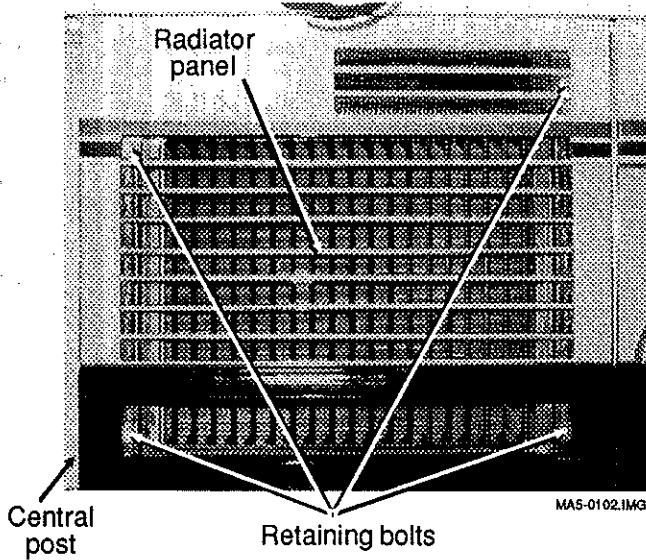

FIG. 2

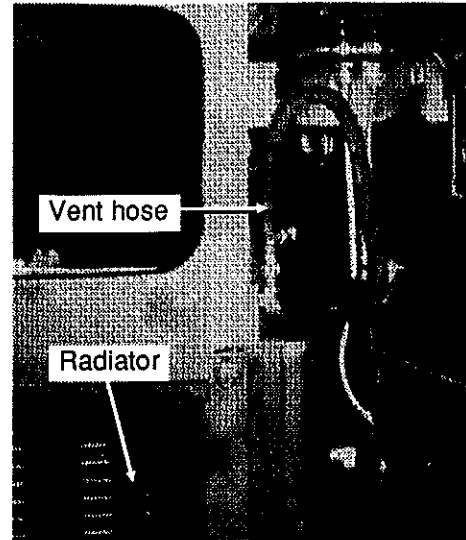

FIG. 3

13. Disconnect the radiator vent hose located in the upper section of the radiator (see fig. 3).
14. Remove the fasteners securing the radiator upper bracket to the structural member (fig. 4).
15. Disconnect the air compressor discharge and governor air lines (see fig. 5).
16. Disconnect the steering pump oil discharge hose (see fig. 5).
17. Disconnect the surge tank hose from the pressure cap which is located behind the radiator near the floor, then remove ties and retaining clips in order to free the hose.

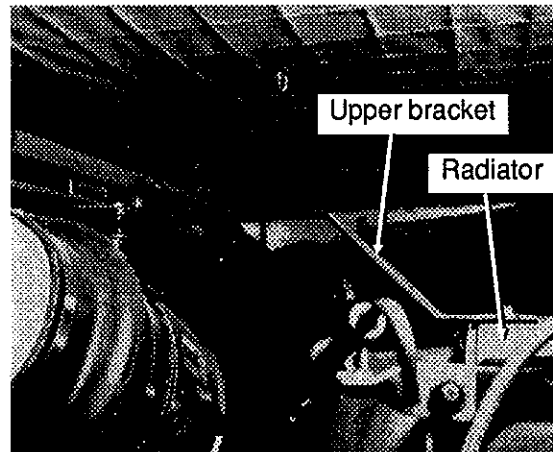

FIG. 4

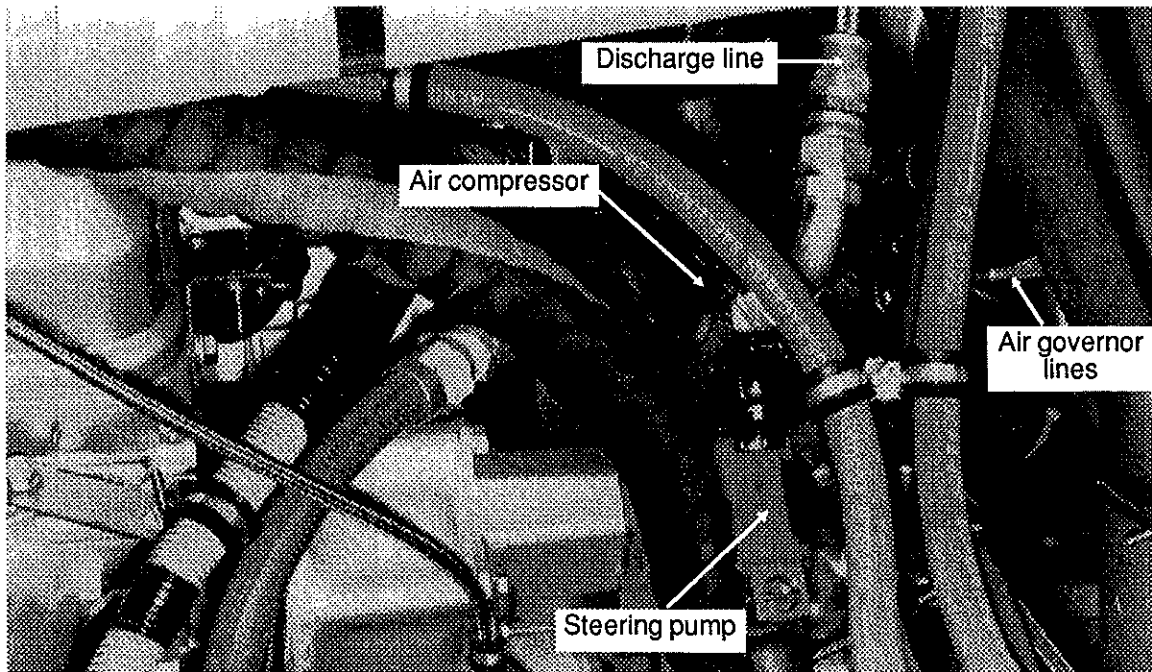

FIG. 5

18. Close the two (2) fuel shut-off valves, then disconnect hoses from valves (see fig. 6).
19. Remove the fasteners securing the air intake duct bracket to the ceiling (see fig. 6).
20. Disconnect hose from oil pressure gauge (see fig. 7).
21. Disconnect the shutterstat air line from the air manifold (see fig. 7).
22. Disconnect from air intake duct, the ether discharge hose of the electrically operated cold starting aid (if vehicle is so equipped).
23. Disconnect the mechanical water temperature sending unit from thermostat housing.
24. Disconnect both fuel hoses from fitting on ceiling (see fig. 7).

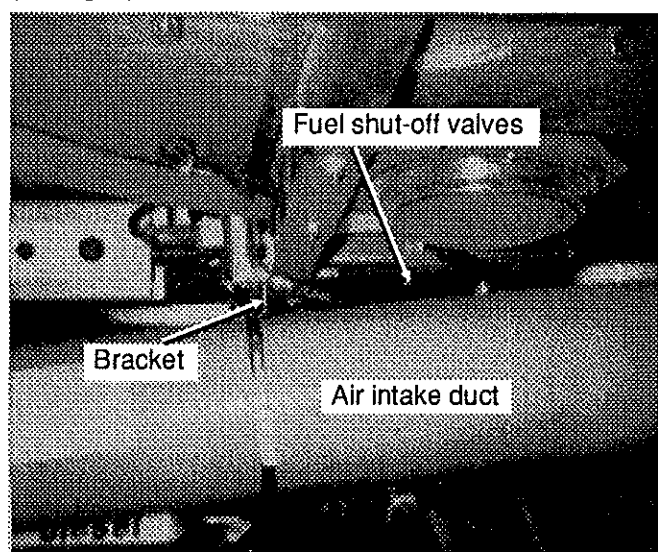

FIG. 6

MA5-0106.IMG

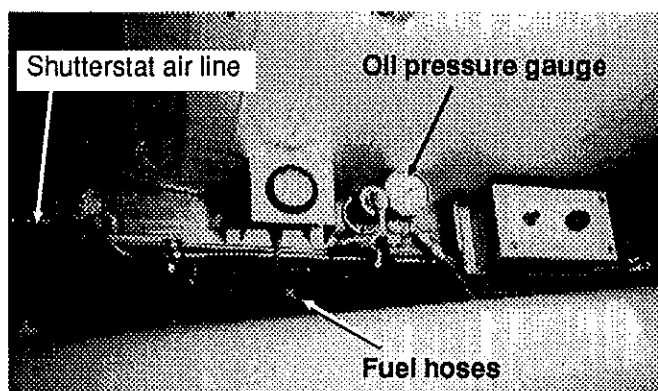

FIG. 7

MA5-0107.IMG

25. From access in front of engine, disconnect both air supply lines leading to the belt tensionner air cylinders (see fig. 8).
26. Disconnect the coolant return pipe located in front of engine (see fig. 8).

27. Disconnect the section of the coolant pipe between the transmission oil cooler and the next connection (see fig. 8); remove the fasteners holding the coolant pipe bracket to the engine cradle, then remove the pipe.
28. Unbolt the belt tensionner air cylinder from the A/C compressor.
29. Open the second and third R.H. side baggage compartment doors, unscrew 1/4 of a turn the five (5) retaining screws of the engine access panel, then open and hold panel with the provided hook.
30. Disconnect both engine coolant vent hoses located on the thermostat housing and on the coolant return pipe.
31. Disconnect the four (4) coolant pipes as illustrated in figure 9.
32. Disconnect the air supply line from the retarder cylinder.

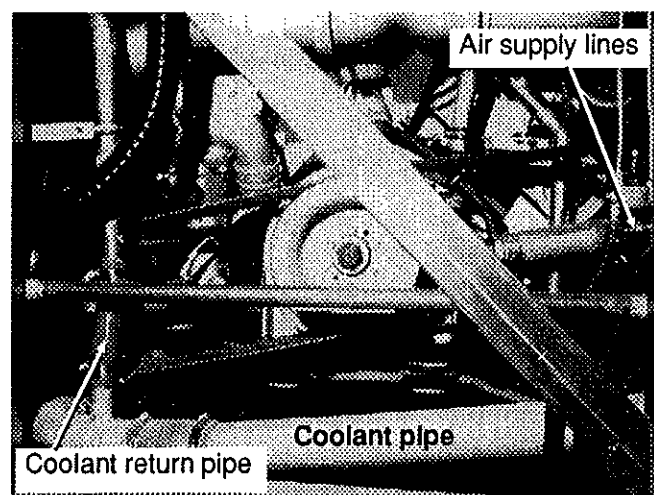

FIG. 8

MA5-0108.IMG

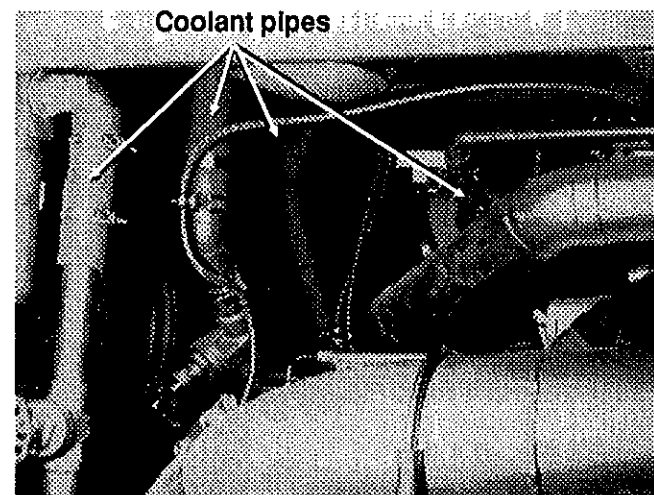

FIG. 9

MA5-0109.IMG

## 01. ENGINE

33. Disconnect the engine cradle ground cable from the structural member (see fig. 10).
34. Disconnect the wiring harness connectors (C-25, C-26, C-28) from "Engine" junction box (see fig. 10).
35. Disconnect the main feeder cable from the engine junction box (see fig. 10).
36. Disconnect the lower hydraulic hose from the Tee fitting of the hydraulic oil filter (see fig. 10).
37. To perform the following steps in the propeller shaft area, disconnect both hydraulic oil delivery hoses from the hydraulic oil tank (see fig. 11).
38. Disconnect the coolant make-up hose running along the rear wall (see fig. 11).
39. Disconnect the propeller shaft as detailed in section 06 - "Propeller shafts".

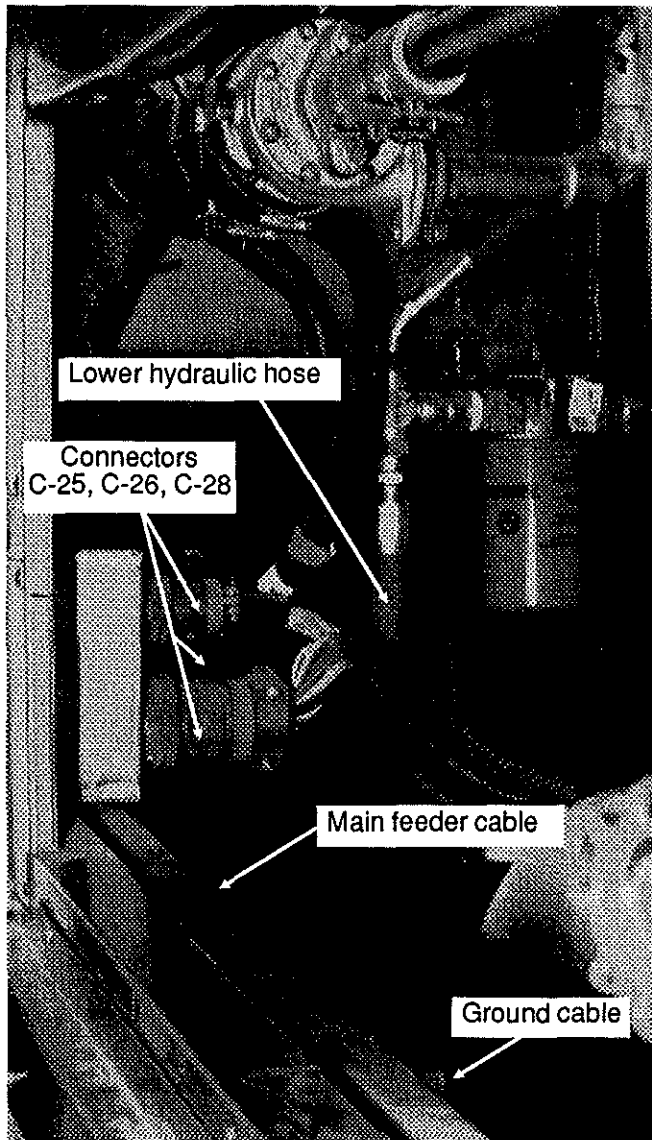

FIG. 10

MA5-0110.IMG

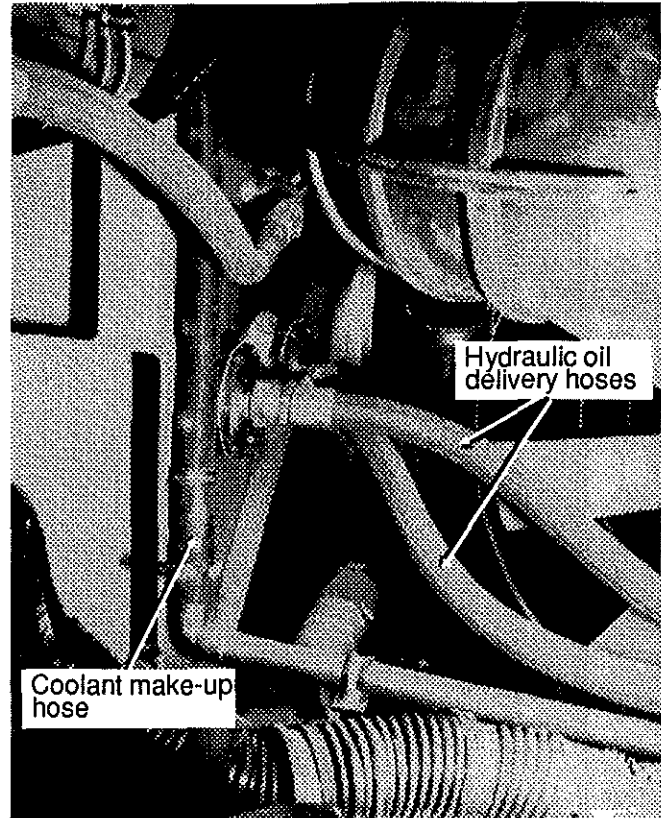

FIG. 11

MA5-0111.IMG

40. Inspect the power plant assembly to ensure that nothing will interfere when sliding out the cradle towards L.H. side of the vehicle.

41. Remove the eight (8) retaining bolts and nuts securing the power plant cradle to the vehicle frame as detailed in figure 12.

42. Using a forklift which minimum capacity must be 5000 lbs (2 300 kg), raise slightly the engine cradle, then pull it out slowly of the engine compartment.

**CAUTION:** Due to the minimum clearance between the power plant equipment and the top of the engine compartment, extreme care should be taken when raising the engine cradle. Clearance between engine cradle and mounting rail should range between 1/4" and 1/2" (6 - 12 mm).

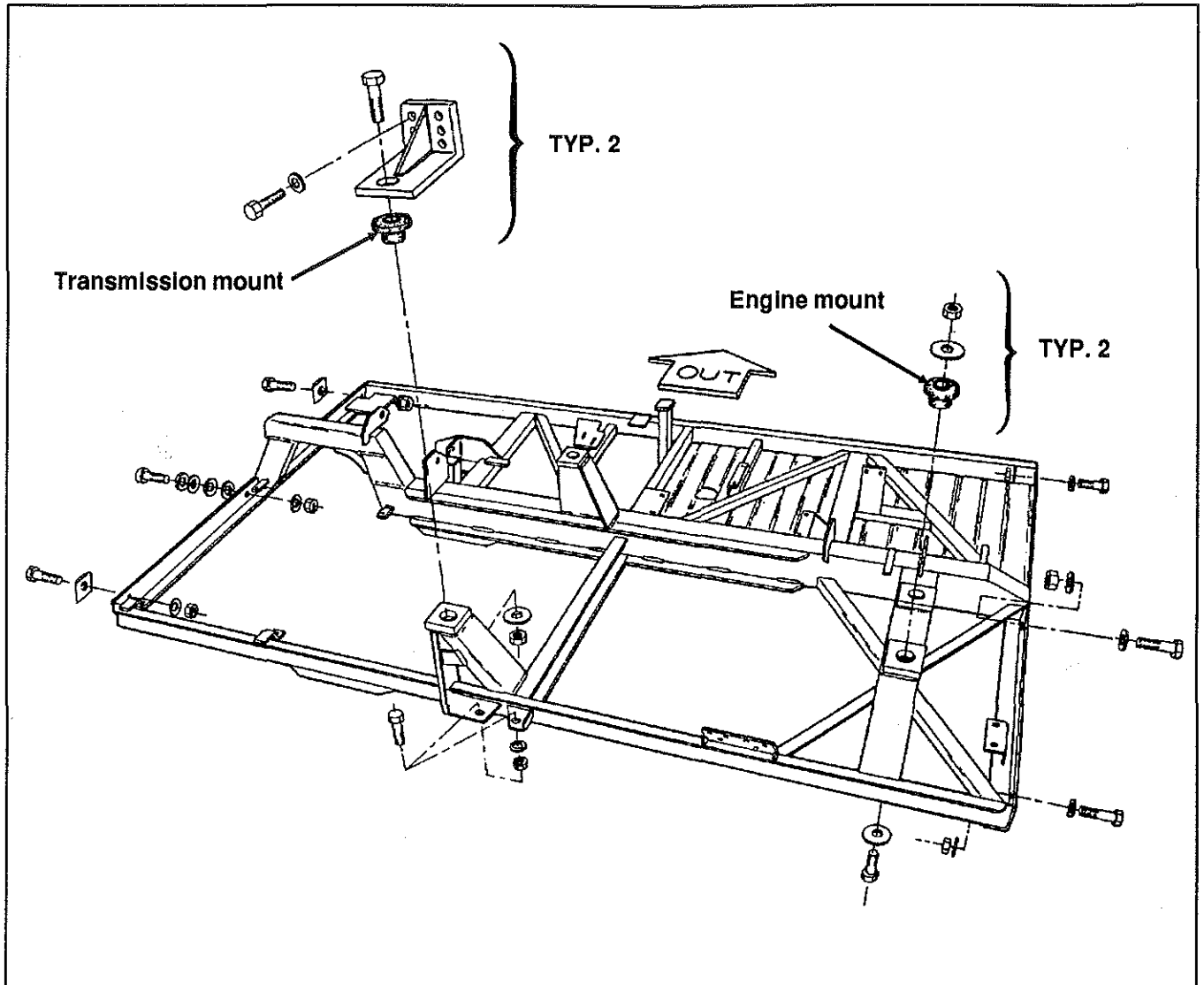

FIG. 12 - Power plant cradle

MA5-0112.IMG

## ENGINE REMOVAL AND INSTALLATION

As engine and transmission are part of the power plant assembly, you must remove the latter as previously instructed, before proceeding with the engine removal and installation.

1. Disconnect the air compressor supply hose from the intake duct.
2. Remove as a unit, the air cleaner housing and the intake duct located between the air cleaner housing and the turbocharger.

**CAUTION: Cover the turbocharger inlet opening to prevent foreign material from entering, as it could damage the parts.**

3. Remove the air cleaner housing retaining bracket located over the transmission.
4. Disconnect the coolant pipe from the water pump (see fig. 13, item 1).
5. Disconnect the coolant pipe located behind the engine turbocharger (see fig. 13, item 2).
6. Disconnect the main coolant return pipe at the three (3) connection points illustrated by items 3,4,5, on figure 13; remove the bracket securing the pipe to the engine, then remove the whole pipe.
7. Disconnect the coolant pipe at points illustrated by items 6, 7, 8 on figure 13, then remove the pipe.
8. Disconnect the coolant pipe located just after the coolant filter (see fig. 13, item 9).
9. Disconnect wiring connector (C-276) from solenoid control relief valve.
10. Disconnect wiring connector (C-277) from fuel filter/water separator.
11. Disconnect wiring harness connector (C-278) from preheating unit.
12. Disconnect wire #57C from preheating unit.
13. Disconnect wiring connector (C-279) from water recirculating pump.
14. Disconnect wiring connectors (C-280, C-281, C-282) from the three (3) water solenoid valves.
15. Remove all retaining clips from the wiring harnesses previously disconnected, then fold the harnesses back on the engine.
16. Disconnect both ground cables from cradle near the solenoid control relief valve.
17. Remove the brackets retaining the hydraulic oil hose to the transmission.

18. Disconnect from fuel filter/water separator, the fuel hose leading to the fuel pump, then remove the retaining clips in order to free the hose.

19. Disconnect the delivery hose from engine oil reserve tank.
20. Disconnect the delivery hose from hydraulic pump.
21. Disconnect air supply lines from belt tensioner air cylinder.
22. Unbolt the belt tensioner air cylinder from the fan transfer shaft bracket.
23. Remove both V belts from radiator fan transfer shaft pulley.
24. Remove the exhaust pipe (refer to section 02 - "Exhaust system").

**CAUTION: Cover the turbocharger outlet opening to prevent foreign material from entering, as it could damage the parts.**

25. Unbolt the bracket holding the retarder hoses to the engine oil pan.
26. Disconnect both coolant hoses from "Perry filters" if vehicle is so equipped.
27. Remove the four (4) engine and transmission mounting bolts (refer to fig. 12 for location of engine and transmission mounts.)
28. Inspect the assembly to ensure that nothing will interfere when lifting the assembly from its base.
29. Use a spreader bar with a suitable sling and an adequate chain hoist to lift the assembly from its base. To prevent bending of the engine lifter brackets, the lifting device should be adjusted so the lifting hooks are vertical. To ensure proper weight distribution, the three (3) engine lifter brackets should be used to lift the engine and transmission assembly.

**WARNING: When lifting the engine and transmission assembly, make sure the lifting device is fastened securely. The lifting device must have a minimum capacity of 4000 lbs (1 800 kg).**

30. Mount the engine and transmission assembly on a suitable stand, then separate the transmission from engine following the procedure given in section 05 - "Transmission".
31. Reinstall the engine and transmission assembly on cradle by reversing the above procedure. Recommended torque for engine and transmission mounting bolts on cradle is 132 - 170 lbs.ft (180 - 230 N.m).



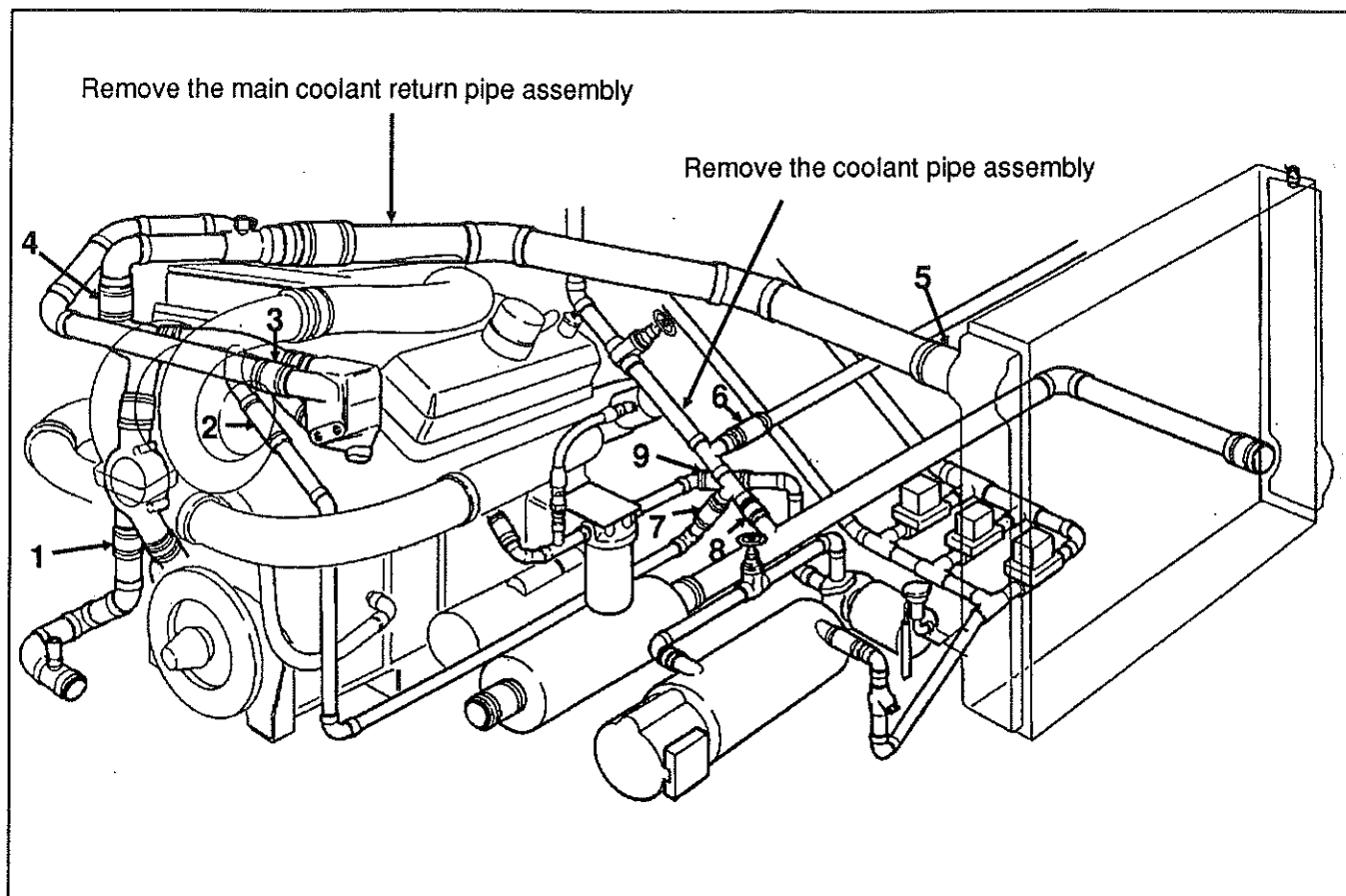

FIG. 13 - Engine disconnect points

MA5-0113.IMG

## POWER PLANT ASSEMBLY INSTALLATION

Installation of the power plant assembly is the reverse of the removal procedure described above plus the following:

1. Apply "Lubriplate #105" grease on mounting rails before reinstalling the engine cradle. Recommended torque for cradle mounting bolts is 132 - 170 lbs.ft (180 - 230 N.m).
2. Refill cooling system and hydraulic fluid tank. If engine fuel system has been drained, it will aid restarting if fuel filters are filled with clean fuel oil. Remove vent plugs and pour clean fuel oil into filter housing until filters are full (refer to section 02 - "Fuel system" for more details).
3. Start engine and check operation. Check fuel, cooling and hydraulic system connections for leakage. Test operation of engine controls and accessories.

## ENGINE MOUNTS

The engine and transmission assembly is mounted to the cradle by means of four (4) rubber mounts, one on each side of the transmission and two at front of engine.

It is recommended that new rubber mounts be installed whenever the engine is removed from the vehicle.

Before installation of new rubber mounts, mounting and socket should be lightly lubricated only with rubber lubricant or water. A special rubber lubricant, "P-80", is available from International Products Corporation, Trenton, New Jersey.

**CAUTION: No other lubricant should be used.**

Improper installation of the press fit type motor mounts can contribute to excessive engine vibrations. When new mounts are installed, mount bolts should be left loose until engine can be run for a short period of time. If engine is accelerated a few times, the rubber mount will find its correct position and then mount bolts can be torqued to 132 - 170 lbs.ft (180 - 230 N.m).



# 02

# FUEL SYSTEM

---

## CONTENTS OF THIS SECTION

FUEL TANK . . . . .	2-1
TANK REMOVAL/INSTALLATION . . . . .	2-2
FILTERS AND WATER SEPARATOR . . . . .	2-2
PRIMING FUEL SYSTEM . . . . .	2-4
FUEL VALVES . . . . .	2-4
FUEL LINE MAINTENANCE . . . . .	2-4
FUEL JUMPER LINE MAINTENANCE AND REUSE . . . . .	2-4
FUEL PUMP FITTING INSTALLATION . . . . .	2-6
FUEL OIL SPECIFICATIONS . . . . .	2-6
AIR CLEANER (DRY TYPE) . . . . .	2-7
AIR CLEANER ASSEMBLY REMOVAL . . . . .	2-7
GENERAL RECOMMENDATIONS . . . . .	2-7
AIR CLEANER RESTRICTION INDICATOR . . . . .	2-7
SPECIFICATIONS . . . . .	2-8



## FUEL TANK

The vehicle is provided with two fuel tanks: one 125 U.S. gallons (473 litres) tank is mounted over the front wheels, while a smaller tank with a capacity of 75 U.S. gallons (284 litres) is located between the side members behind the second front axle, for a total capacity of 200 U.S. gallons (757 litres).

The fuel filler neck is accessible through a hinged access door located over the R.H. side front wheels, while a drain plug in bottom of the smaller tank is accessible from under the vehicle.

The figures 1 and 2 show a schematic layout of the fuel system components.

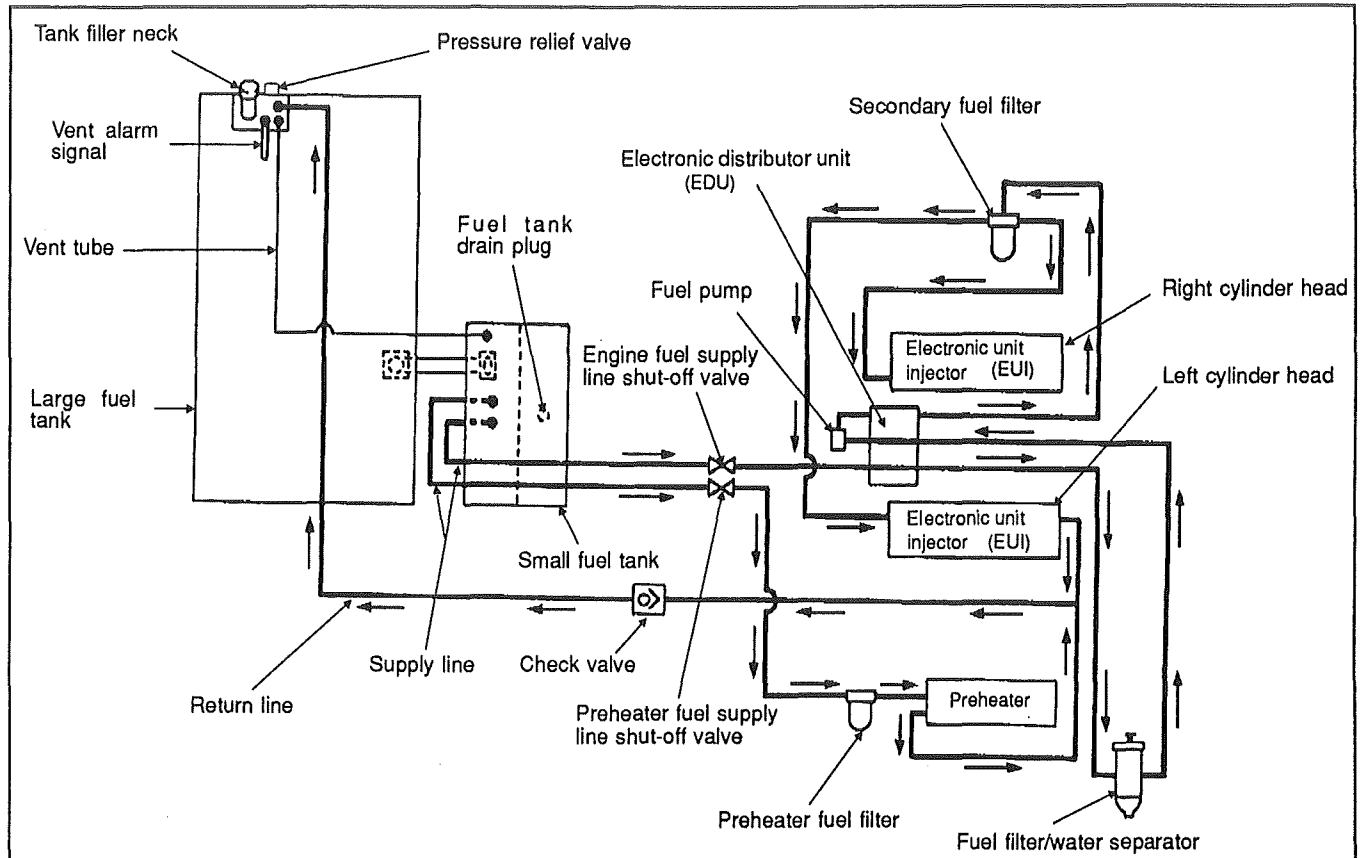

FIG. 1 - Fuel system schematic

MA5-0201.IMG

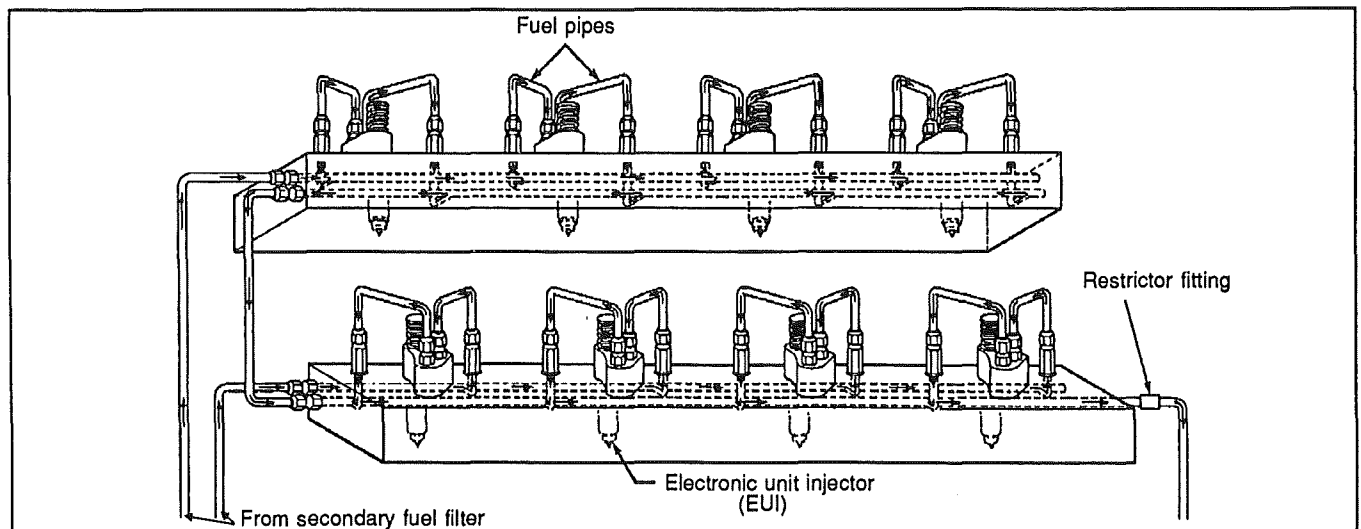

FIG. 2

MA5-0202.IMG

The larger tank is equipped with a vent alarm signal which produces a whistling sound when tanks are 95% full. Afterwards, provided vehicle is parked on level ground, the restrictive vent do not allow to continue filling. A pressure relief valve in the tank relieves high pressure buildup, and an air vent allows offset air in the tanks to escape as the tanks are being filled.

## TANK REMOVAL/INSTALLATION

**NOTE:** Prior to removal, the fuel tanks should be completely drained by unscrewing the drain plug under the small tank. Ensure that you have an adequate container which capacity is equal to the amount of the remaining fuel in the tank(s).

### Removal of the 125 U.S. gallons (473 litres) tank

1. Remove the R.H exterior panel over the front wheels and the fuel tank door. Refer to section 17 under "Panel removal/installation" and "Door removal/installation".
2. Unscrew the four retaining bolts in front of tank, then unscrew the fuel return line and air vent collars over the tank.
3. Disconnect these hoses.
4. From under the vehicle, loosen the nut on the threaded hook located on the L.H. side of vehicle at the back of tank, then push on hook to free the tank.
5. Unscrew the four (4) retaining bolts of the 45° elbow, then remove it.

**CAUTION:** Before proceeding with the following step, ensure that the tank is supported adequately. Failure to do so could result in personal injury as well as damage to the tank.

6. Pull tank from the R.H. side until it is removed from vehicle.

### Installation of the 125 U.S. gallons (473 litres) tank

Reverse removal procedure. However, change the 45° elbow gasket and check for leaks after final installation.

### Removal of the 75 U.S. gallons (284 litres) tank

1. Disconnect the fuel supply lines, the alarm and fuel gauge connector.
2. Unscrew the collar and remove the tube from the 45° elbow.
3. Remove both retaining clips of the air hoses (one on each side).

**CAUTION:** Before proceeding with the following step, ensure that the tank is supported adequately. Failure to do so could result in personal injury as well as damage to the tank.

4. Unscrew the six (6) retaining bolts (3 on each side) of the tank, then pull it lightly in order to remove it from its former position.
5. Unscrew and disconnect the air vent hose over the tank.

### Installation of the 75 U.S. gallons (284 litres) tank

Reverse removal procedure and check for leaks after final installation.

## FILTERS AND WATER SEPARATOR

The fuel system is equipped with a fuel filter/water separator and a secondary fuel filter for additional protection of the injectors. The filter/water separator, as well as its brackets and fuel line connections, are shown in figure 3. Neither of their element or cartridge is cleanable and must be replaced when dirty or clogged. For maximum efficiency, service filters as follows:

**NOTE:** The service intervals of the filter/water separator element and the secondary fuel filter cartridge are determined by the operating conditions and cleanliness of the type of fuel used.

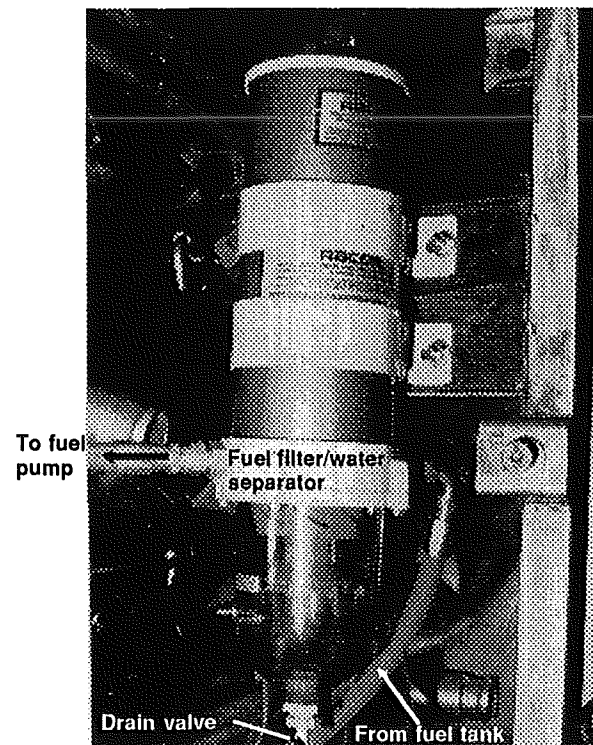

FIG. 3

MA5-0203.IMG

## "Racor" fuel filter/water separator servicing

The "Racor" fuel filter/water separator, model 1000 FG, is located in engine compartment along the radiator. The water separator must be drained periodically or when the indicator light on central dashboard panel turns on. Proceed as follows to drain the water separator.

1. With engine off, close the valve of the engine fuel supply line. Refer to "Fuel valves" for location of the fuel supply line valve.
2. Turn drain valve under water separator a quarter of a turn counterclockwise to drain accumulated water and contaminants.
3. Close the drain valve.
4. Open the valve of the engine fuel supply line.

**CAUTION: If the water separator continuously requires draining, it is possible that water or sediment is accumulated in the fuel tanks. To correct this situation, open the drain plug under the smaller tank when the fuel gauge indicates the tank is 1/4 full in order to drain any contaminant.**

Proceed as follows to replace the water separator element.

1. Drain the fuel filter/water separator as stated previously.
2. With engine off and the engine fuel supply line valve closed, remove T-handle and the water separator lid.
3. Twist and pull out element.
4. Install new element.
5. Prime unit by pouring clean fuel into filter/water separator housing until full.
6. Replace water separator lid and hand tighten T-handle.
7. Open the engine fuel supply line valve.

Refer to the "Racor" service manual annexed at the end of this section for instructions on disassembly, cleaning and other service procedure.

## Secondary fuel filter servicing

The secondary fuel filter is located on the R.H side of engine behind the oil filter. It is a spin-on type, and must be replaced at 10,000 miles (16 000 km) intervals.

**CAUTION: Do not attempt to clean and reinstall a filter element.**

Proceed as follows to change the filter cartridge.

1. Stop engine, close the engine fuel supply line valve, then unscrew the filter and discard it.
2. Fill new filter replacement cartridge about two-thirds (2/3) full with clean fuel oil. Apply a thin coat of clean fuel oil on gasket.

3. Install the new filter assembly and tighten it to one half (1/2) turn after gasket contact.
4. Open the engine fuel supply line valve.
5. Start the engine and check for leaks.

**NOTE: To improve starting of DDEC engines, have replacement filters filled with fuel and ready to install immediately after used filters are removed. This will prevent possible siphoning, causing fuel system aeration.**

**NOTE: If the engine fails to start after replacement of the fuel filter element(s), the fuel system will require priming with tool J 5956, or equivalent.**

## Preheater filter servicing (Webasto)

The preheater has an independant fuel supply line which is provided with a fuel filter (see fig. 4) located in the engine compartment near the preheater, and connected in series with the preheater fuel supply line.

The cartridge element should be changed according to the use of the preheater, or after two years.

Proceed as follows to change the cartridge element.

1. Stop engine, close the preheater supply line valve located over the air compressor in engine compartment. Refer to "Fuel valves" for location of the fuel supply line valve.
2. Place a suitable container under the filter and open the drain cock. Loosen the cover nut sufficiently to allow the fuel oil to drain freely, then close drain cock.
3. While supporting the housing, unscrew the cover bolt, then remove the housing and its element.
4. Remove and discard the filter element.
5. Wash the housing thoroughly with clean fuel oil and dry with compressed air.

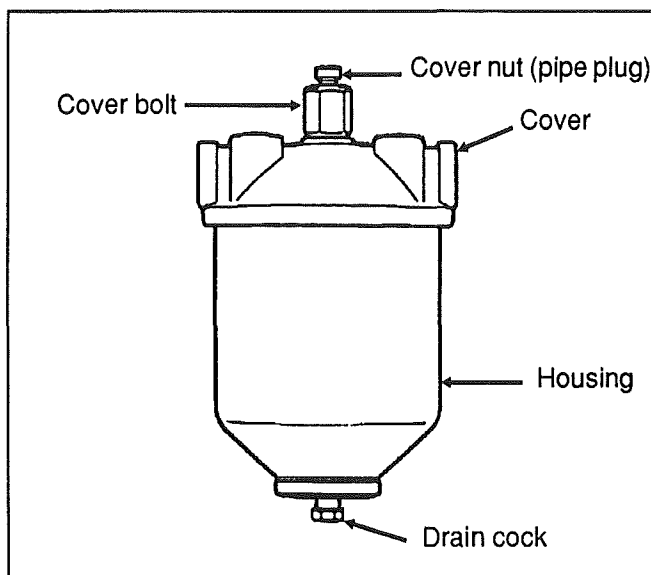

FIG. 4

MA5-0204.IMG

6. Inspect the element seat and the retaining ring to ensure they have not slipped out of place. Check the spring by pressing on the element seat. The seat must return against the retaining ring when released; if necessary, replace the spring.

7. Place a new element (with the inscription "Top" facing upward) over the center stud and push it down against the element seat. Ensure the drain cock is closed, then fill the housing about two-third (2/3) full with clean fuel oil.

**NOTE: Thoroughly soak the density-type element in clean fuel oil before installing it. This will expel any air entrapped in the element and is conducive to a faster initial preheater start.**

8. Place the housing and its element in position under the cover, then tighten the cover bolt in the center stud.

9. With the housing and the gasket properly positioned, torque the cover bolt to 12-14 ft.lbs (16-19 N.m).

10. Remove the cover nut (pipe plug) on top and complete filling of the housing with clean fuel oil.

11. Start the preheater and check for fuel oil leaks.

## PRIMING FUEL SYSTEM

The problem with restarting an engine that has run out of fuel, is that after the fuel is exhausted from the tank, it is pumped from the fuel filter/water separator and sometimes partially removed from the secondary filter before the fuel supply is insufficient to sustain engine firing. The fuel filter/water separator and secondary filter must be free of air in order for the systems to provide adequate fuel for the injectors. When the engine runs out of fuel, the following procedures must be performed before restarting.

1. Fill the fuel tank with the recommended fuel oil. If only partial filling is possible, add a minimum of 10 gallons (38 liters) of fuel.

2. Prime or purge the system by blocking or disconnecting the line from the fuel pump, then apply fuel under pressure 60-80 psi (410-550 kPa) to the inlet of the secondary filter. If the system is to be purged of air as well, allow fuel to flow freely from the fuel return line until a solid stream without air bubbles is observed.

3. Start the engine and check for leaks.

**NOTE: It may be necessary to remove a valve cover and loosen a fuel pipe nut in order to bleed any trapped air from the fuel system. Ensure the fuel pipe nut is retightened before installing the valve cover.**

## FUEL VALVES

Two manual valves, located on engine compartment ceiling above the air compressor, are provided for the servicing and maintenance of the fuel system. The first

one opens and closes the engine supply line, while the second one opens and closes the preheater supply line.

To close one or both valves, turn the control a quarter of a turn (1/4) in the clockwise direction, using a wrench or if vehicle is so equipped, the red button.

## FUEL LINE MAINTENANCE

The three (3) fuel lines and their connectors must be checked periodically to prevent leaks or loose connections. There are two supply lines routed from the smaller tank to the engine and preheater, while the other from the large tank works as a return line.

For further details, refer to the schematic diagram of the fuel system in figure 1.

## FUEL JUMPER LINE MAINTENANCE AND REUSE

Maintenance and service personnel should be aware that severe engine damage could result from fuel oil leakage into the lubricating oil, and should therefore follow proper procedures when removing, handling and installing fuel jumper lines (fuel pipes).

The fuel jumper lines which carry fuel to and from the fuel injectors must be handled and installed very carefully to prevent line damage that can result in fuel leaks and subsequent dilution of the lubricating oil. Fuel diluted lubricating oil can result in severe engine damage. Severe fuel leakage, if not detected, can also result in an overfilled crankcase (oil pan) which can cause an abnormal amount of fuel and lubricating oil vapor to escape from the engine and crankcase breathers. An abnormal concentration of fuel and lube oil vapors is flammable and could ignite in a closed engine compartment.

The following are some of the conditions that can result in fuel jumper line leakage:

1. Improper handling and storage of jumper lines when servicing the engine can result in physical damage and contamination.

2. Careless use of special tool (socket) during removal or installation can cause a jumper line to bend and be permanently distorted.

3. Reuse of a bent or distorted jumper line can result in excessive stress and cause the line to crack or fracture at or above the flared ends of the jumper line. A fuel leak will ultimately result.

4. Excessive tightening of the jumper line nut will distort and fracture the flared end of the jumper line, resulting in a fuel leak. (See NOTE following step 6.)

5. Damaged threads and flare seats on the injector and cylinder head jumper line connectors can also result in fuel leakage.



6. Leaks can also occur at injector filter nut gaskets and/or cylinder head connector washers due to distortion, damage, or incorrect torque.

Fuel jumper lines are preformed to facilitate easy installation on the injector and cylinder head jumper line connectors. Do not attempt to straighten distorted or bent jumper lines for reuse, because the straightening process may cause the jumper line to weaken or fracture and result in fuel leakage.

**NOTE:** When installing fuel jumper lines, use Detroit Diesel special tool socket (J8932-01). Do not exceed the following torque: 12-15 ft.lbs (16-20 N.m) on standard jumper lines.

**CAUTION:** Damage to the jumper line flares and connector seats can result from excessive tightening, causing fuel leakage into the lubricating oil.

Figure 5 depicts specific conditions which servicing personnel should look for when determining if a fuel jumper line is suitable for reuse.

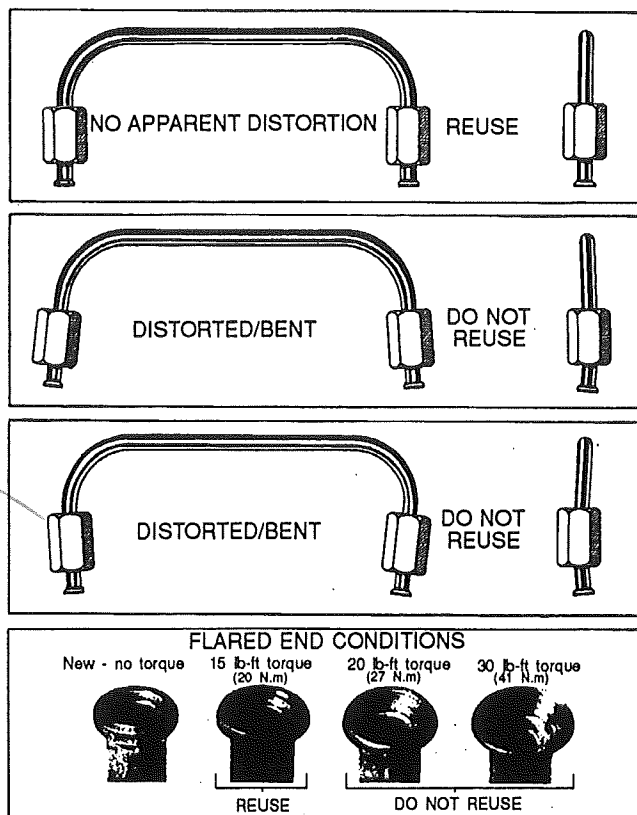

FIG. 5 - Fuel pipe conditions

MA5-0205.IMG

## Checking for fuel leaks

The following troubleshooting procedure is recommended after installation of fuel jumper lines and/or connectors to determine if fuel leakage is present.

Always check the fuel system for leaks after injector or fuel jumper line replacement and any time the fuel connections under the rocker cover are suspected for leak-

ing. Failure to correct a fuel leak in this area can lead to dilution of the lube oil. **Use one of the following methods to check for leaks.**

### Method A

**Use when the engine has been operating 20-30 minutes.** After operating the engine, shut it off and remove the rocker covers. Inspect the lube oil puddles that normally form where the fuel connectors join the cylinder head and where the fuel jumper lines join the fuel line nuts. If there is any leakage at these connections, the lube oil puddles will be smaller or thinner than the puddles on the connectors that are not leaking. Disassemble, inspect and correct or replace the suspect part (connector washer, connector, injector or jumper line). Test and reinspect.

### Method B

**Use when the engine is not operating such as during or after repairs.** Remove the rocker covers. Pour clean lube oil over the fuel jumper lines and connectors which would normally be splashed with oil during engine operation. This will cause oil puddles to form at the joining surfaces as mentioned in Method A. Plug the fuel return line at a convenient location (cylinder head or fuel tank, for example). Disconnect the fuel pump supply line at the inlet of the secondary filter. Connect an external source of pressurized fuel (60-80 psi (410-550 kPa)) to the inlet of the secondary filter cover. Install a pressure gauge (0-100 psi (0-700 kPa)) at the outlet of the filter cover.

Gauge installation can be accomplished by installing a "T" fitting between the filter cover and outlet line or by removing the pipe plug at the outlet in the cover. Use of a gauge will allow ready reference to the fuel pressure being maintained for this test. Severe leaks are immediately visible and minor leaks take longer to appear. It may be necessary to maintain fuel pressure for a period of 20 to 30 minutes in order to find minor leaks. Leaks may be repaired by replacing damaged parts or determining if the part is loose and below torque specifications. Test and reinspect.

If injectors are suspected of leaking and contributing to dilution of the lube oil, they should not be tested by pressurizing the fuel system as in Method B. Injectors should be removed from the engine and high pressure tested as outlined in the Detroit Diesel Service Manual.

### Method C

**Use while the engine is operating at 400-600 rpm.** Apply an outside fuel source capable of 60-80 psi (410-550 kPa) to the outlet side of the secondary filter. Pour lube oil over the fuel jumper lines and connectors so that oil puddles form where jumper lines and connectors meet. Install a valve and a pressure gauge in the fuel

return line. With the engine idling, close the valve enough to raise the engine fuel pressure to 60-80 psi (410-550 kPa). After 10-20 minutes, inspect the oil puddles to see if any have become smaller or run off completely. The undiluted oil will hang the same as when the oil was poured on. Repair and retest.

Slightly worn injector plungers may leak more under these conditions. This leakage will not occur while the engine is running because of the dynamic and pressure conditions that exist.

## Method D

**Fluorescent dye fuel leak testing.** When testing an engine that has been in service, it will be preferable to use the fluorescent dye and black light method of testing. Proceed as follows:

1. Mix 4 oz. (120 ml) of fluorescent additive (Detroit Diesel #J28431) with 4 U.S. gallons (15 l) of clean diesel fuel (#1 or #2) in a clean container. The container should be marked "Test Fuel" and be resealable so that it won't be contaminated when not being used.
2. Isolate the engine fuel system so that the supply and return fuel lines are connected only to the test fuel container. It will be necessary to intermittently check the fuel level to maintain an adequate supply.
3. Warm up the engine by operating it at maximum no-load speed for approximately 15 minutes.

**WARNING:** When operating the engine in a service garage or in a closed area, the exhaust must be vented to the outside. Place the shop vent over the exhaust outlet pipe. Avoid contacting the engine exhaust pipe, as this could cause severe burns. Moreover, stay away from moving parts during the following steps.

4. With the engine idling and the rocker covers removed, shine the black light over the head assembly. The lube oil will show a dull blue. If a fuel leak is present, the fuel with the fluorescent dye will glow a bright yellow.
5. After the cause of the fuel leak has been determined and corrected, wipe the area and fuel connections clean and recheck with the black light. When no leaks are present, reassemble the unit with the original fuel lines and normal fuel source. It is not necessary to change the fuel filters. Run the engine to purge the air from the fuel system.

**With the engine at rest, all injectors will leak to some extent when pressurized. The leakage occurs because there is no other place for the pressurized fuel to go. When the low and high pressure cavities in the injector are subjected to the high test pressure, fuel is forced past the plunger into the rack and gear cavity. Result: Droplets of fuel form at the rack and drip off. Special consideration must be given to this weepage. If considered to be excessive, the injector**

**should be removed and tested for pressure holding capacities.**

**NOTE:** Since all leakage or spillage of fuel during leak detection testing dilutes the lube oil, the final step in maintenance of this type should include lube oil and lube oil filter changes.

## Points to remember:

1. Lube oil puddle inspection is one method of testing the fuel system for internal leaks. The missing puddles show where the leaks are. This test can be performed any time the rocker covers are removed, after the fuel jumper lines and connectors have been splashed with clean lube oil and there is normal fuel pressure in the system.
2. All leakage or spillage of fuel during leak detection testing further dilutes the lube oil.
3. The final step in maintenance of this type should include lube oil and lube oil filter changes if a fuel leak is detected.
4. Oil level above the dipstick "full" mark or a decrease in lube oil consumption may indicate internal fuel leaks.
5. Improper storage, handling, or installation of jumper lines can cause fuel leakage, resulting in lube oil dilution and severe engine damage.

## FUEL PUMP FITTING INSTALLATION

Before installing inlet or outlet fittings on the fuel pump, coat the threads lightly with "Gasolite, Permatex II", or an equivalent non-hardening sealant. To prevent sealant from entering the fuel system, do not apply sealant on the first two (2) threads of the fittings. Torque fittings to 20-25 ft.lbs (27-34 N.m).

**CAUTION:** Do not install fittings with Teflon tape or paste, since this can result in fuel pump cover damage (cracking) before the required torque is reached.

## FUEL OIL SPECIFICATIONS

The quality of fuel oil used for high speed diesel engine operation is a very important factor in obtaining satisfactory engine performance, long engine life, and acceptable exhaust emission levels.

The fuel oil should meet ASTM designation D-975. Grade 1-D is recommended, but grade 2-D is also acceptable. Note that these grades are very similar to grade DF-1 or DF-2 of Federal Specifications VV-F-800.

For detailed fuel recommendations, refer to "Detroit Diesel Service Manual".

## AIR CLEANER (DRY TYPE)

The vehicle is equipped with a two stage dry-type, replaceable element air cleaner, located in the engine compartment. To service the air cleaner, open the second and third R.H. compartment doors of the front section, then open the engine access door.

Engine air enters the air cleaner through an intake duct located over the radiator on the L.H. side of vehicle, then flows through a pre-cleaner and finally, through the air cleaner. The pre-cleaner consists of a centrifugal air cleaner in series with a replaceable impregnated paper filter element (air cleaner). Dust and moisture will be drained by means of a discharge tube at the bottom of pre-cleaner.

### Pre-cleaner servicing

The first stage centrifugal air cleaner tends to be self-cleaning; however, it should be inspected and any accumulated foreign material removed during the periodic replacement of the impregnated paper filter element.

### Air cleaner servicing

Stop the engine and loosen the wing nut retaining the air cleaner element to the air cleaner. Remove the element by pulling on handle in center of air cleaner element.

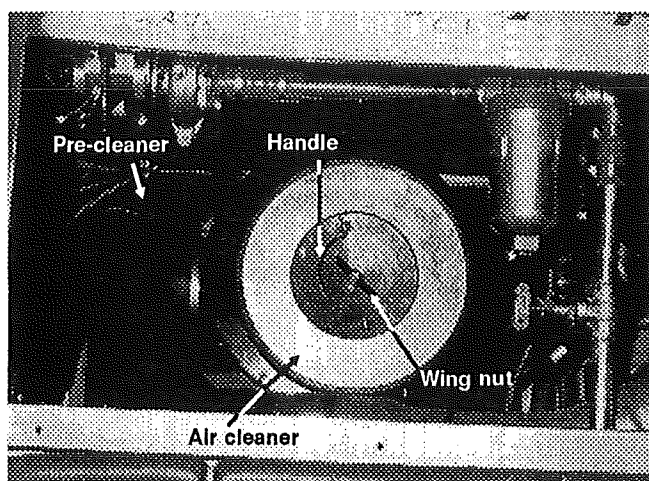

FIG. 6

### Installation of new element

1. Inspect the gasket sealing surface inside the air cleaner. It must be smooth, flat and clean.
2. Install the air cleaner element.
3. Be certain element seals securely.
4. Inspect element cover gasket and replace if necessary.

## AIR CLEANER ASSEMBLY REMOVAL

Whenever it becomes necessary to remove the air cleaner assembly (dry type) for maintenance or other repair in this area, great care should be taken when installing air cleaner assembly. The pre-filter should be installed snugly in the air duct and clamped tightly to the air cleaner inlet to prevent any dust infiltration into air cleaner.

## GENERAL RECOMMENDATIONS

1. Never operate the engine without an element in the air cleaner assembly.
2. Use only original equipment filter elements.
3. Whenever element has been removed from air cleaner housing, inside surface of housing must be cleaned with a soft clean cloth.
4. Do not ignore the warning given by the air restriction indicator, as this could result in serious engine damage.
5. Store new elements in a closed area free from dust and possible damage.
6. Use recommended air cleaner element when replacement is required.

## AIR CLEANER RESTRICTION INDICATOR

A resettable restriction indicator is installed on engine air intake duct over the oil reserve tank in engine compartment, to constantly monitor the level of vacuum between the air cleaner and engine, in order to detect and indicate an abnormal increase in vacuum due to a dirt-laden and therefore restricted air cleaner element.

When red signal locks in full view, the air cleaner element must be replaced and the indicator must be reset by pressing on its extremity.

## SPECIFICATIONS

### FUEL FILTER/WATER SEPARATOR

Make . . . . . Racor  
Type . . . . . 1000 FG  
Fuel filter Prévost Number . . . . . 53-0150  
Element cartridge Prévost Number . . . . . 53-0194

### SECONDARY FUEL FILTER

Make . . . . . AC  
Type . . . . . Spin-on  
Element & gasket AC Number . . . . . 25010778 (TP-916)  
Element Prévost Number . . . . . 51-0128  
Element torque . . . . . 1/2 turn after gasket contact

### PREHEATER FUEL FILTER

Make . . . . . Fram  
Model . . . . . FB M1110-PB  
Fuel filter Prévost Number . . . . . 87-0895  
Element cartridge Fram Number . . . . . C-1110-PB  
Element cartridge Prévost Number . . . . . 87-0894  
Element torque . . . . . 12-14 ft.lbs (16-19 N.m)

### FUEL TANKS

#### Large Tank

Capacity . . . . . 125 U.S. gal (473 liters)

#### Small Tank

Capacity . . . . . 75 U.S. gal (284 liters)

### AIR CLEANER

#### Air cleaner

Make . . . . . Nelson  
Air cleaner Prévost Number . . . . . 53-0199  
Element cartridge Nelson Number . . . . . 70337-N  
Element cartridge Prévost Number . . . . . 53-0197

#### Pre-cleaner

Make . . . . . Donaldson  
Model . . . . . PVH001230  
Pre-cleaner Prévost Number . . . . . 53-0195

**AIR RESTRICTION INDICATOR**

Make . . . . . Donaldson  
Model . . . . . RBX00-2220  
Indicates . . . . . at 20" (508 mm) of water  
Restriction indicator Prévost Number . . . . . 53-0161









# 03

# COOLING SYSTEM

---

## CONTENTS OF THIS SECTION

DESCRIPTION . . . . .	3-1
ROUTINE MAINTENANCE . . . . .	3-1
LOCATION OF COOLING SYSTEM DRAIN POINTS . . . . .	3-7
DRAINING COOLING SYSTEM . . . . .	3-9
REFILLING COOLING SYSTEM . . . . .	3-9
SPIN-ON TYPE COOLANT FILTER . . . . .	3-9
RADIATOR . . . . .	3-9
RADIATOR SHUTTER . . . . .	3-10
SHUTTER . . . . .	3-10
SHUTTERSTAT . . . . .	3-10
RADIATOR VARIABLE SPEED FAN . . . . .	3-11
FAN GEAR BOX . . . . .	3-12
FAN TRANSFER SHAFT . . . . .	3-12
BELT TENSIONER . . . . .	3-13
BELT REPLACEMENT . . . . .	3-13
SPECIFICATIONS . . . . .	3-15



## DESCRIPTION

The engine is cooled by a liquid which is circulated within the cooling system. This includes the water pump, radiator, surge tank, pressure cap and the engine thermostats. A oil driven fan, mounted on side of the transmission, pulls air through the radiator cores for cooling.

A pressure cap located in engine compartment between the radiator and the preheating system unit (fig. 1), is used to maintain a constant pressure within the cooling system. Temperature of the coolant is controlled by two thermostats located in housings at front of engine. The cooling system is filled through a filler cap at the surge tank. A small access door located on left side of vehicle is used for this purpose (fig. 2).

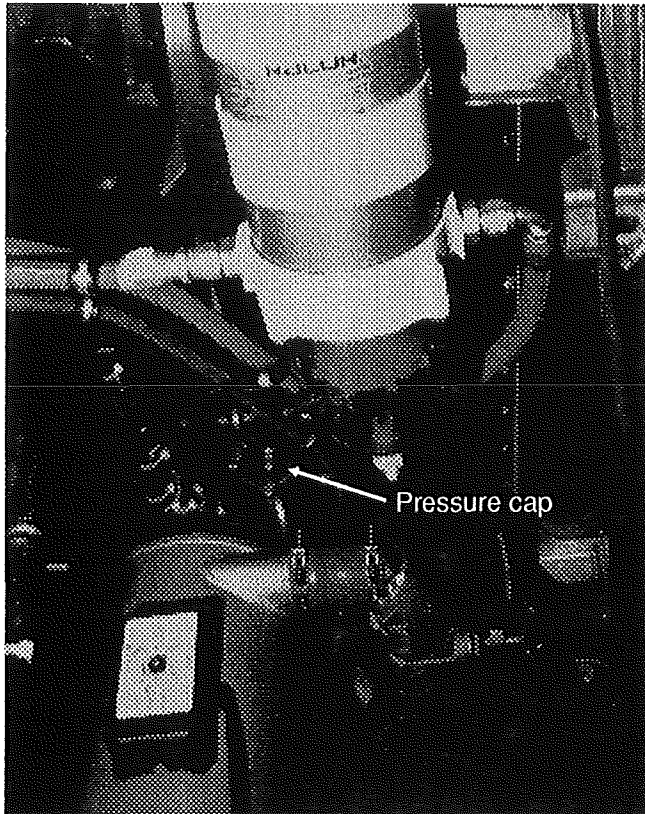

FIG. 1

MA5-0301.IMG

A defective thermostat which remains closed, or only partially opened, will restrict coolant flow and cause overheating of the engine. A thermostat, which is stuck in the fully open position, may prevent the engine from reaching its operating temperature.

Coolant from the bottom of the radiator is circulated through the oil transmission heat exchanger to absorb heat from the transmission fluid.

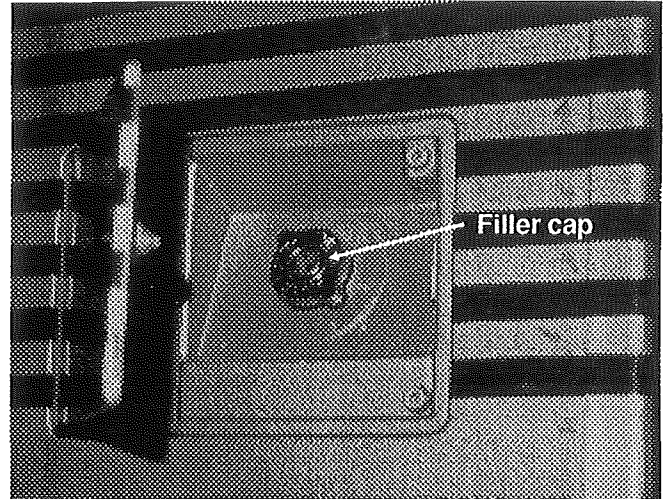

FIG. 2

MA5-0302.IMG

The engine cooling system is also used to provide hot coolant for the coach heating system. Refer to "Heating and air conditioning" (SECTION 16) for information relative to water circulation within the coach heating system.

A warning device consisting of an indicator probe mounted in the surge tank is designed to warn the driver when there is a low level of engine coolant. The device will light the "Check Engine" tell-tale lamp in the central dashboard panel if the coolant level is too low, and the engine will stop after a few minutes.

## ROUTINE MAINTENANCE

A systematic routine inspection of cooling system components is essential to ensure maximum engine and heating system efficiency.

Check coolant level in the surge tank daily, and correct if required. Check antifreeze strength.

Rustproof the cooling system twice a year; drain and fill the system once a year with a properly inhibited water/antifreeze solution. (Refer to "Corrosion inhibitor vital".)

Check belts for proper tension; adjust as necessary and replace any frayed or badly worn belts.

Check radiator cores for leaks and ensure that the cores are not clogged with dirt or insects. Clean cores with a low pressure air hose to avoid damaging the fins. Steam clean if required.

Inspect the water pump operation. A leaky pump sucks in air, increasing corrosion.

Repair all leaks promptly. Unchecked leaks can lead to trouble. Inspect and tighten radiator mounts periodically. Test and replace thermostats regularly.

Leaks at the thermostat housing hose connections may be caused by deformation and rough surfaces on the castings of the hose mounting surfaces. It is recommended that "Dow Corning RTV-102 Compound" or any equivalent product be applied on cast surfaces prior to hose installation.

**CAUTION: Castings should be clean and free of oil and grease before applying compound. No other sealer should be used with RTV-102 compound.**

### Hose inspection

Rotten, swollen, and worn out hoses or loose connections are frequent causes of cooling system problems.

Serious overheating is often caused by old hose collapsing or from rotten rubber shedding from hoses and clogging the coolant passages.

Connections should be inspected periodically and hose clamps tightened. Replace any hose found to be cracked or swollen. When installing a new hose, clean pipe connections and apply a thin layer of a non-hardening sealing compound. Replace worn out clamps or clamps that pinch hoses.

### Testing antifreeze solutions

Always test the solution before adding water or antifreeze. The engine should be warmed up to operating temperature. Fill and empty the tester several times to warm before using. Keep the tester clean inside and out. Some testers will indicate correct freezing point only when the test is made at a specific temperature. Other testers are provided with thermometers and tables and indicate freezing points corresponding to readings made at various temperatures. Disregarding temperature of the solution may cause an error as large as 30 °F (16,6 °C). Read and follow the instructions furnished by the tester manufacturer.

### Thawing cooling system

If the cooling system becomes frozen solid, place the coach in a warm area until the ice is completely thawed. Under no circumstances should the engine be operated when the cooling system is frozen, as it will result in engine overheating due to insufficient coolant.

### Coolant requirements

Successful engine operation depends on the correct selection and maintenance of the coolant. A suitable coolant must meet the following requirements:

1. Provide for adequate heat transfer.
2. Provide a corrosion-resistant environment within the cooling system.

3. Prevent formation of scale or sludge deposits in the cooling system.
4. Be compatible with cooling system hose and seal materials.
5. Provide adequate freeze protection during cold weather operation and boil-over protection in hot weather.

### Water

Whether of drinking quality or not, any water will produce a corrosive environment in the cooling system, and the mineral content may permit scale deposits to form on internal cooling system surfaces. Therefore, water selected as a coolant must be properly treated with inhibitors to control corrosion and scale deposition.

To determine if a particular water is suitable for use as a coolant when properly inhibited, the following characteristics must be considered: the concentration of chlorides and sulfates, total hardness, and dissolved solids.

Chlorides and/or sulfates tend to accelerate corrosion, while hardness (percentage of magnesium and calcium salts broadly classified as carbonates) causes scale deposits. Total dissolved solids may cause scale deposits, sludge deposits, corrosion, or a combination of these. Chlorides, sulfates, magnesium, and calcium are among the materials which make up dissolved solids. Water within the limits specified in Table 1 is satisfactory as an engine coolant when proper inhibitors are added. The procedure for evaluating water intended for use in a coolant solution is shown in Table 2.

	PARTS PER MILLION	GRAINS PER GALLON
Chlorides (Maximum)	40	2.5
Sulfates (Maximum)	100	5.8
Total Dissolved Solids (Max.)	340	20
Total Hardness (Maximum)	170	10

TABLE 1

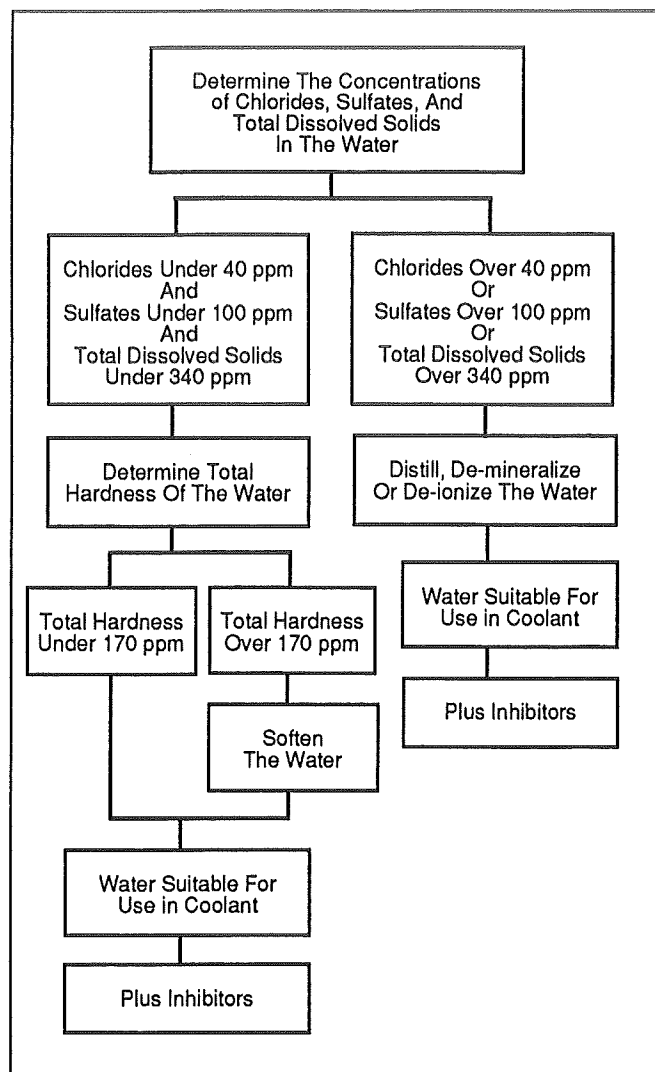

TABLE 2

## Corrosion inhibitors vital

A corrosion inhibitor is a water-soluble chemical compound which protects the metallic surfaces of the cooling system against corrosive attack. Some of the more commonly used corrosion inhibitors are chromates, borates, nitrates, nitrites, and soluble oil. (Soluble oil is not recommended as a corrosion inhibitor.) Depletion of all types of inhibitors occurs through normal operation. Therefore, strength levels must be maintained by adding inhibitors as required after testing the coolant.

The importance of a properly inhibited coolant cannot be overstressed. A coolant which has insufficient inhibitors, the wrong inhibitors, or worse no inhibitors at all invites the formation of rust and scale deposits within the cooling system. Rust, scale, and mineral deposits can wear out water pump seals and coat the walls of the cylinder block water jackets and the outside walls of the cylinder liners. As these deposits build up, they insulate the metal and reduce the rate of heat transfer. For example, a 1/16" deposit of rust or scales on 1" of cast iron is equivalent to 4 1/4" of cast iron in heat transferability (see fig. 3).

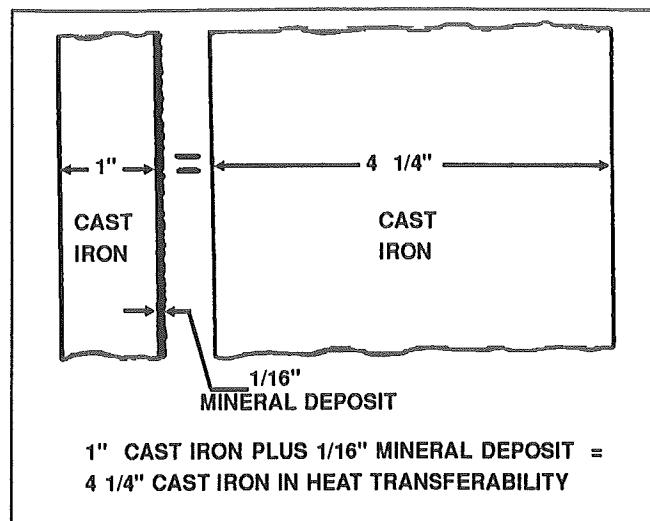

FIG. 3 - Heat transfer capacity

MA5-0303.IMG

An engine affected in this manner overheats gradually over a period of weeks or months. Liner scuffing, scoring, piston seizure, and cylinder head cracking are the inevitable results. An improperly inhibited coolant can also become corrosive enough to "eat away" coolant passages and seal ring grooves and cause coolant leaks to develop. If sufficient coolant accumulates on top of a piston, a hydrostatic lock can occur while the engine is being started. This, in turn, can result in a bent connecting rod.

An improperly inhibited coolant can also contribute to cavitation erosion. Cavitation erosion is caused by the collapse of bubbles "vapor pockets" formed at the coolant side of an engine component. The collapse results from a pressure differential in the liquid caused by the vibration of the engine part. As bubbles collapse, they form pin points of very high pressure. Over a period of time, the rapid succession of millions of tiny bursting bubbles can wear away "erode" internal engine surfaces.

Components such as water pump impeller and cylinder liners are especially susceptible to cavitation erosion. In extreme cases, their surfaces can become so deeply pitted that they appear to be spongy, and holes can develop completely through them.

## Chromates

Sodium chromate and potassium dichromate are two of the best and most commonly used water system corrosion inhibitors. Care should be exercised in handling these materials due to their toxic nature.

Chromate inhibitors should not be used in antifreeze solutions. Chromium hydroxide, commonly called "green slime", can result from the use of chromate inhibitors with antifreeze. This material deposits on the cooling system passages, reducing the heat transfer rate and resulting in engine overheating. Engines which

have operated with a chromate-inhibited water must be chemically cleaned before the addition of antifreeze. A commercial heavy-duty descaler should be used in accordance with the manufacturer's recommendation for this purpose.

### Soluble oil

Soluble oil has been used as a corrosion inhibitor for many years. It has, however, required very close attention relative to the concentration level due to adverse effects on heat transfer if the concentration exceeds 1% by volume. For example, 1.25% of soluble oil in the cooling system increases fire deck temperature by 6%, and a 2.50% concentration raises fire deck temperature up to 15%. Soluble oil is not recommended as a corrosion inhibitor.

### Non-chromates

Non-chromate inhibitors (borates, nitrates, nitrites, etc.) provide corrosion protection in the cooling system with the basic advantage that they can be used with either a water or a water-and-antifreeze solution.

### Inhibitor systems

An inhibitor system is a combination of chemical compounds which provide corrosion protection, pH control, and water-softening ability. Corrosion protection is discussed under the heading, "*Corrosion inhibitors vital*". pH control is used to maintain an acid-free solution. The water-softening ability deters formation of mineral deposits. Inhibitor systems are available in various forms, such as coolant filter elements, liquid and dry inhibitor additives, and as integral parts of antifreeze. Inhibitor additives

Commercially packaged inhibitor systems are available which can be added directly to the engine coolant. Both chromate and non-chromate systems are available, and care should be taken regarding inhibitor compatibility with other coolant constituents. Non-chromate inhibitor systems are recommended for use in Detroit Diesel engines. These systems can be used with either water or water-and-antifreeze solutions and provide corrosion protection, pH control, and water softening. Some non-chromate inhibitor systems offer the additional advantage of a simple on-site test to determine protection level. Since they are added directly to the coolant, they require no additional hardware or plumbing.

All inhibitors become depleted through normal operation, and additional inhibitor must be added to the coolant as required to maintain original strength levels. Always follow the supplier's recommendations on inhibitor usage and handling.

### Test methods

Test kits and test strips are commercially available to check engine coolant for corrosion inhibitor strength level. Coolant should be tested to determine the need for corrosion inhibitor supplements and the amount required. Do not use one manufacturer's test to measure the inhibitor strength level of another manufacturer's product. Always follow the manufacturer's recommended test procedures.

### Silicate dropout from antifreeze

When the use of aluminum parts increased in automobile engine cooling systems, many antifreeze manufacturers reformulated their products to include increased amounts of silicates to protect these components from corrosion. As a consequence, most automotive grade antifreeze formulations sold today contain three to eight times as much silicate as they did several years ago. The corrosion inhibitor supplements used to maintain corrosion protection in heavy-duty diesel engine coolants also contain silicates.

If an antifreeze solution is overconcentrated and/or unnecessarily large amounts of corrosion inhibitor supplements are used, the excess silicate will "*drop out*" of the coolant, and silica gel will build up in the cool, low-flow zones of the engine, especially the radiator, oil cooler core, heater core, and aftercooler. The reduced coolant flow that results from silica gel buildup can lead to engine overheating and serious engine damage.

In the wet state, the silica gel takes on the color of the antifreeze or inhibitor supplement used in that system. Although silica gel is non-abrasive, it can pick-up solid particles in the coolant and become a gritty, abrasive deposit that can cause excessive wear of water pump seals and other cooling system components. When dried, the silicate appears as a white powdery deposit.

These conditions can also contribute to silicate dropout:

1. Air entrapment in the coolant.
2. Improper (low) coolant level in the system.
3. Insufficient maintenance of cooling system.
4. A reduced flow condition caused by kinked hoses.
5. Poor pressure cap seal or improper pressure rating.
6. Use of extremely hard water in coolant solutions.
7. Unusually high engine operating temperatures.

### Antifreeze solutions

An ethylene glycol base permanent type antifreeze solution is recommended for several reasons. This type of antifreeze provides excellent freeze and overheat protection and also contains a corrosion inhibitor. Solutions of less than 30% of antifreeze do not provide sufficient corrosion protection, while solutions with an

antifreeze concentration greater than 67% by volume adversely affect freeze protection and heat transfer (see fig. 4).

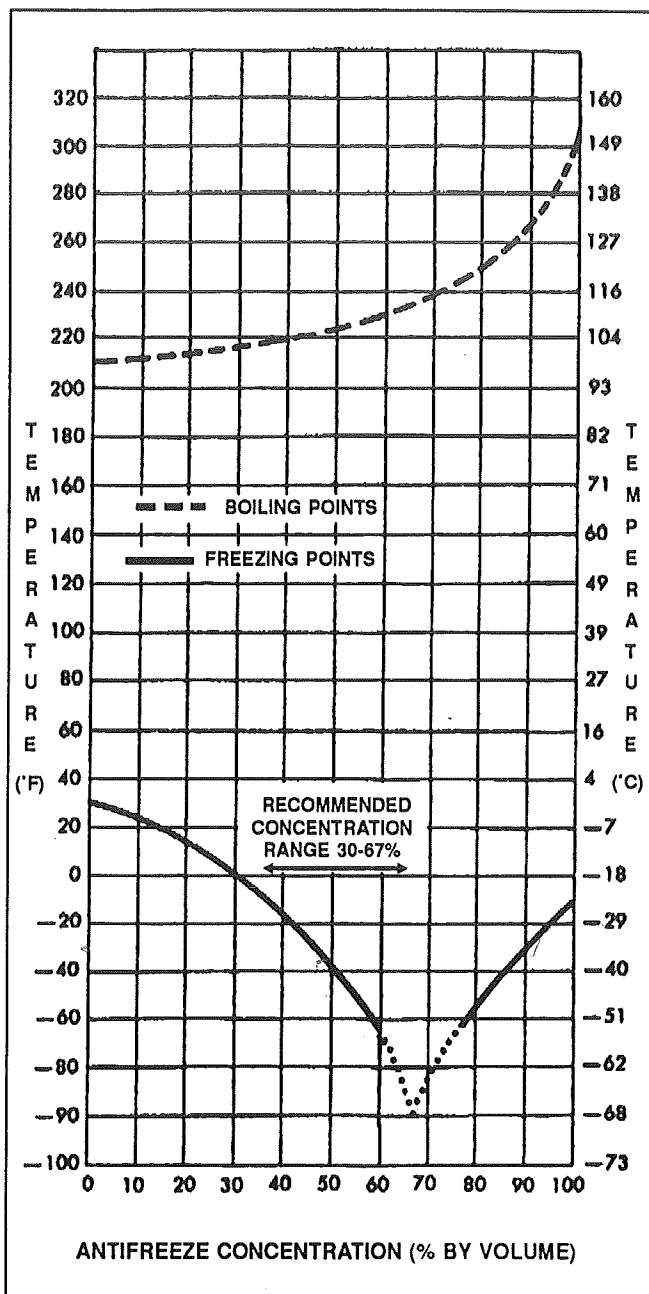

FIG. 4 - Coolant freezing and boiling temperatures vs. antifreeze concentration (sea level)

Inhibitor depletion will occur in ethylene glycol base antifreeze through normal service. The inhibitors should be replenished at approximately 500 operating hours or 20,000 miles (32,000 km) intervals with a non-chromate inhibitor system, such as NALCOOL 2000. Several brands of permanent antifreeze containing various types of sealer additives are available. In the past, coaches operating with these types of antifreeze have experienced plugging problems in various areas of the cooling system. For this reason antifreeze containing sealer additives is not recommended.

For optimum engine performance the following conditions should be met:

1. Use an antifreeze that meets the GM 6038M formulation which limits the amount of silicate to 0.15 percent maximum. Other antifreeze formulations meeting the 0.15 percent maximum silicate level and the GM 1899M performance specifications are also acceptable.
2. Use antifreeze solutions at the concentration required for freeze protection in your operational area. Do not use more than 67% antifreeze, since this can adversely affect coolant freezing and boiling temperatures, increase silicate levels, and reduce heat transfer.
3. Never use 100% antifreeze for makeup coolant. Mix the makeup solution at the same concentration as the original fill.
4. Do not add corrosion inhibitor supplements to new antifreeze solutions, except for the initial fill of Series 92 engines.
5. Use corrosion inhibitor supplements only as required to maintain proper system protection. Always test the coolant first to determine the need for additional inhibitor. Test systems are commercially available. Contact the inhibitor manufacturer for his recommendations. **Do not overinhibit.**
6. Use water that meets the recommended limits (refer under the heading "Water").

When engine overheating can be traced to silicate dropout and plugging of engine coolant passages, a commercial non-acid cleaner should be used to remove the silica gel from the engine cooling system. This can be done without disassembling the engine. Among these non-acid cleaners are the following:

- A- Nalprep 2001 - Nalco Chemical Co.
- B- Fleet Restore - Fleetgard, Inc.
- C- Peak professional Cooling System Cleaner - Northern Petrochemical Co.

The specific manufacturer's recommendations for use of these materials and safe handling practices must be followed.

If the non-acid cleaner fails to remove the silicate deposits as evidenced by continued engine overheating, the individual affected components must be disassembled and placed in an agitated caustic solution and/or cleaned mechanically (rodded out or ultrasonically cleaned).

**NOTE: Do not flush the engine cooling system with caustic solutions, since this can result in damage to both metallic and non-metallic components.**

**WARNING: To avoid personal injury, use extreme care when handling caustic solutions. Wear safety glasses or face shield and the appropriate protective clothing (rubber gloves, apron, boots, etc.).**

## Low silicate antifreezes that meet GM 6038M formulation specification

Company	Product	Packaging	Contact
TEXACO (1)	2055 (Was JC-04)	DRUM/BULK	TEXACO 713-650-4359
BASFWYANDOTTE (1)	241-7	DRUM/BULK	BASF 800-526-1072
INTER. HARVES. (1)(5)	I.H. ANTIFREEZE	GALLON	I.H. DEALER
OLD WORLD	FULL FORCE	GAL/DRUM/BULK	OLD WORLD
TRADING CO. (1)	ADVANCE	GAL/DRUM/BULK	ILLINOIS 312-699-2000 ELSEWHERE 800-323-5440
NORTHERN PETRO- CHEMICAL (2)	ALL WEATHER (NPC 220)	GAL/DRUM/BULK	S.W. REG. 214-659-1636 EAST. REG. 210-823-1884 MID. REG. 312-298-1800
DOW CHEMICAL CANADA (3)	731	DRUM/BULK	DOW 519-339-3130
HOUGHTON CHEMICAL CORP. (4)	SECURITY (701)	GAL/DRUM/BULK	HOUGHTON 617-254-1010

(1) Generally available in U.S.A.

(2) Generally available within 750 mile radius of Chicago.

(3) Generally available in Canada.

(4) Generally available in northeastern U.S.A.

(5) I.H. antifreeze in Canada has high silicate content.

**NOTICE: This is a partial listing as there may be other suppliers who can make available low silicate antifreeze.**



# LOCATION OF COOLING SYSTEM DRAIN POINTS

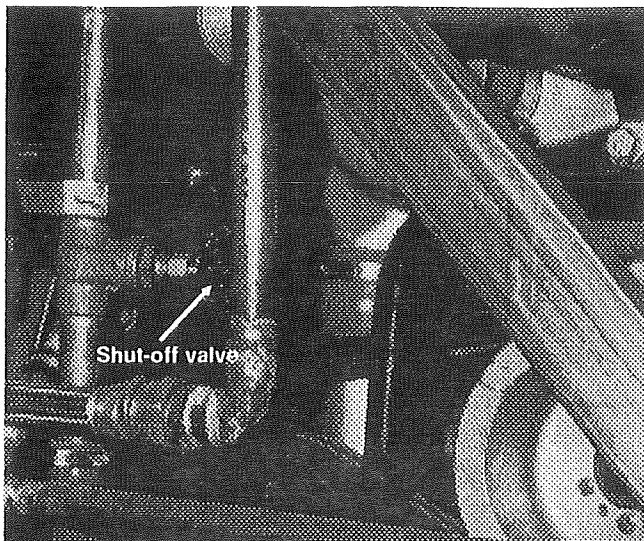

FIG. 5

MA5-0305.IMG

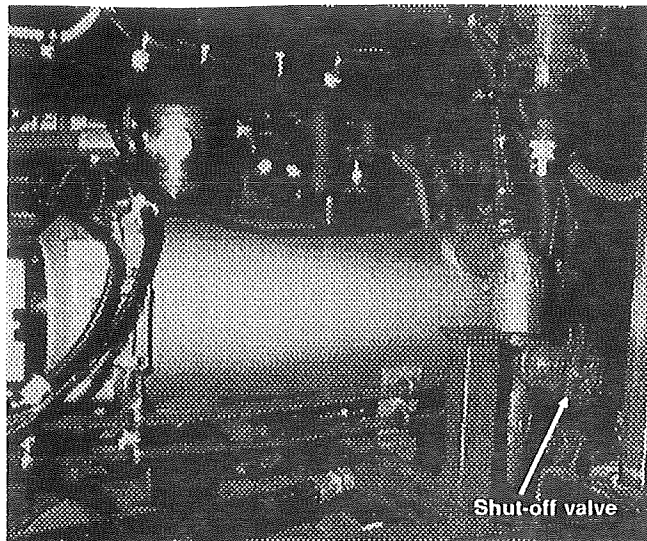

FIG. 6

MA5-0306.IMG

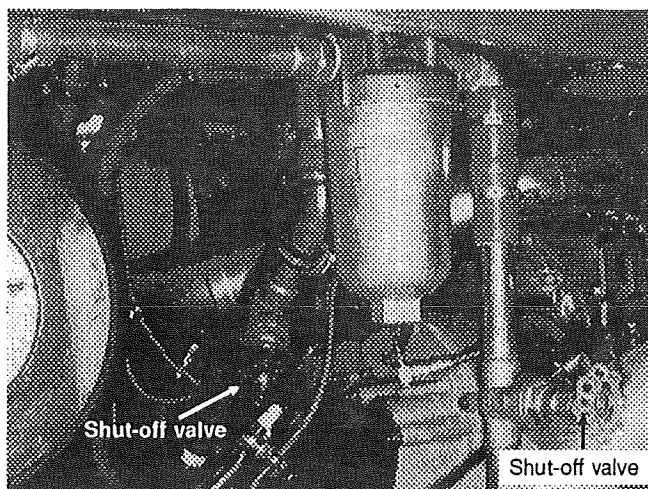

FIG. 7

MA5-0307.IMG

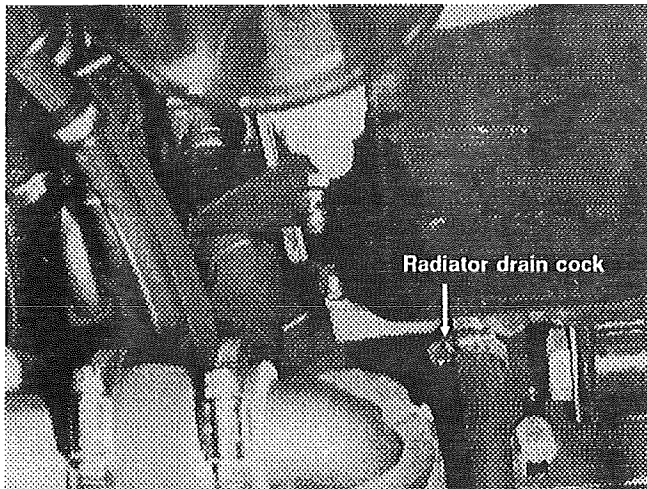

FIG. 8

MA5-0308.IMG

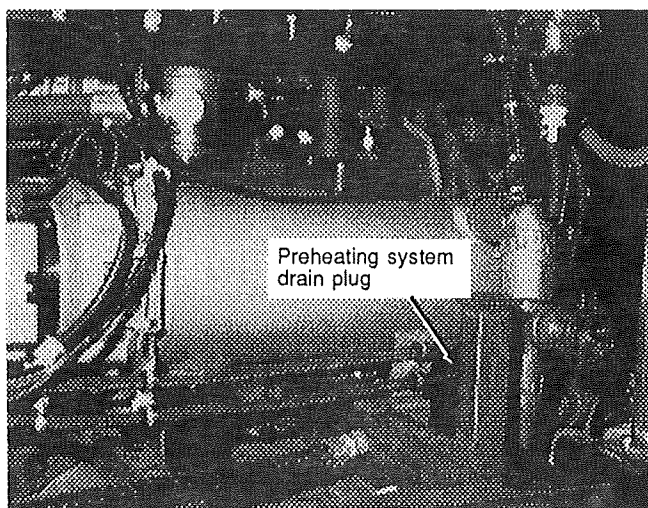

FIG. 9

MA5-0306.IMG

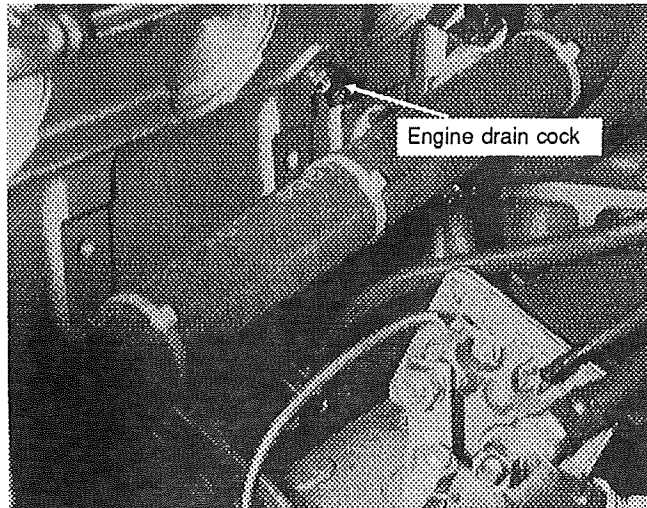

FIG. 10

MA5-0310.IMG

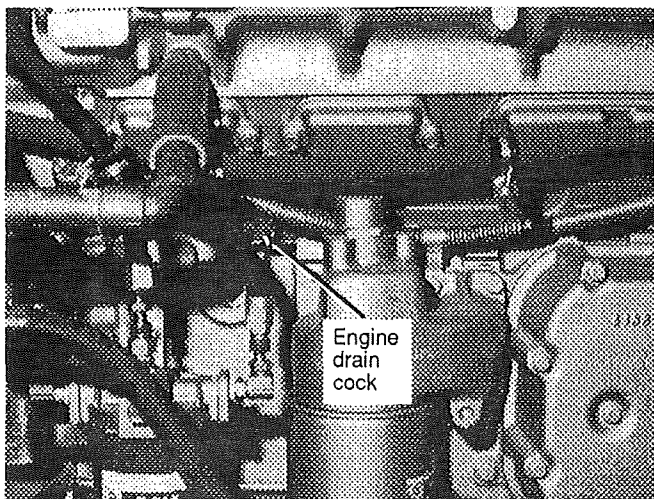

FIG. 11

MA5-0311.JPG

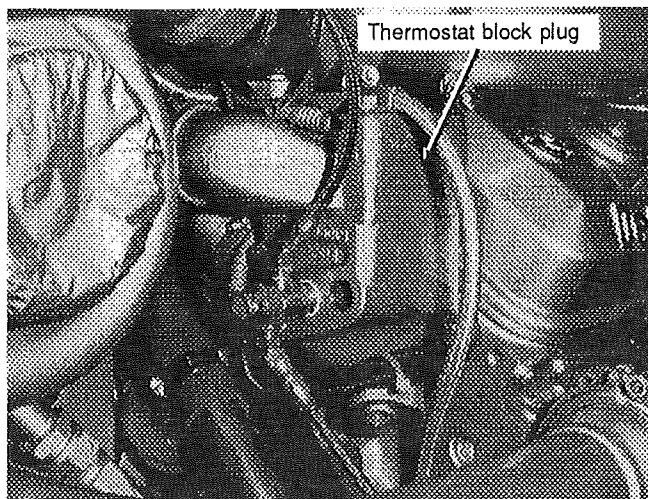

FIG. 12

MA5-0312.JPG

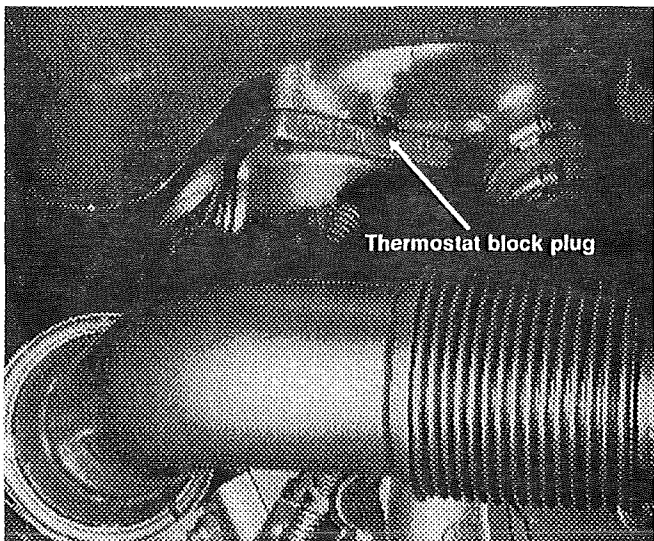

FIG. 13

MA5-0313.JPG

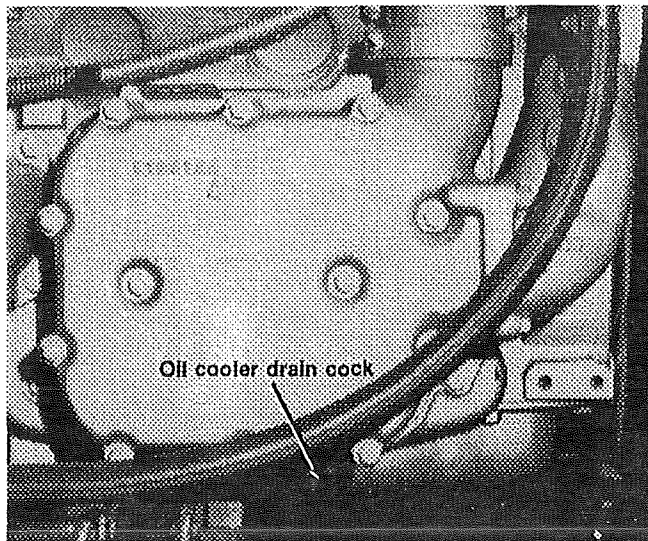

FIG. 14

MA5-0314.JPG

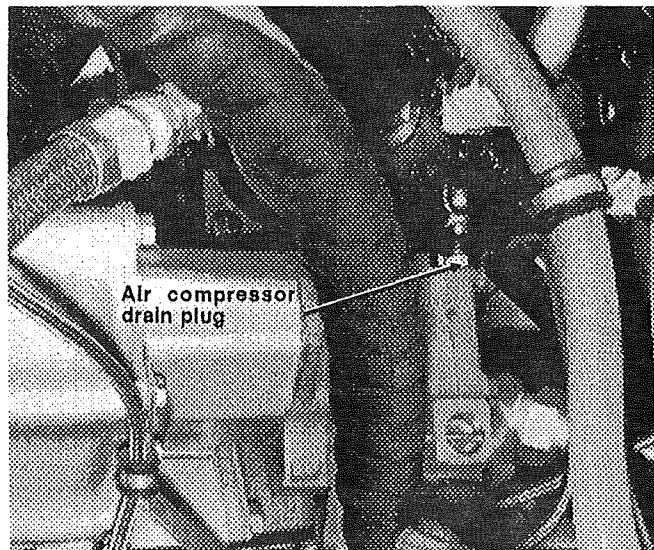

FIG. 15

MA5-0315.JPG

*Handwritten mark*

## DRAINING COOLING SYSTEM

The cooling system may be completely or partially drained by using the following procedures.

To drain only the engine and related components, proceed as follows:

1. Stop engine and allow engine to cool. Close shut-off valve located in front of the engine, near the water pump (see fig. 5). This valve is accessible by removing the front engine access panel located in the first baggage compartment.
  2. Close shut-off valve located in the engine compartment in front of the pre-heating system right under the fuel filter/water separator (see fig. 6).
  3. Close shut-off valve located behind the alternator. This valve is accessible by the small engine access door on the R.H. side of vehicle (see fig. 7).
  4. Close shut-off valve located near the coolant filter of the rear heating unit (see fig. 7).
  5. Remove the surge tank filler cap. Removal of the filler cap permits air to enter the cooling passages and the coolant to drain completely from the system.
- WARNING: Use extreme care when removing the surge tank filler cap. The sudden release of pressure from a heated cooling system can result in loss of coolant and possible personal injury (scalding) from the hot liquid.**
6. Open the radiator drain cock located at the bottom of the radiator (see fig. 8).
  7. Remove drain plug under the pre-heating system (see fig. 9).
  8. Open both engine side drain cocks (see fig. 10 et 11).
  9. Remove plugs on both cylinder head thermostat blocks (see fig.12 et 13).
  10. Open oil cooler drain cock ( see fig. 14).
  11. Remove air compressor drain plug (see fig. 15).

To drain the entire system, resume the previous steps while maintaining the shut-off valves in their "open" position, and follow the procedure under the heading "*Draining the heating system*" in section 16, to drain simultaneously the heating units.

## REFILLING COOLING SYSTEM

To fill the system, close all drain plugs and cocks. (Refer to previous heading "*Draining cooling system*" for location of drain points.) If the heater line shut-off valves are closed, they should be opened. Fill the system through the surge tank filler neck located behind a small access door on L.H. side of vehicle.

**NOTE: The cooling system is completely filled when coolant reaches the surge tank filler neck.**

When the cooling system is filled to capacity, expansion of the coolant takes place as it heats up. During this initial warm up period it is possible to lose as much as a gallon and a half of coolant. No further excessive coolant loss should be experienced after this period.

**CAUTION: Never pour cold coolant into a hot engine. The sudden change in temperature may crack the cylinder heads or block.**

## SPIN-ON TYPE COOLANT FILTER

### Description

Two spin-on type coolant filters, located near the engine oil cooler, are available as optional equipment (see fig.16). The filters should be replaced every 500 hours, or 20,000 miles (32 000 km). PREVOST recommends the use of Perry Filter PFC-24A (PREVOST P.N. 55-0276).

### Replacement

Close the two shut-off cocks at the filter mounting heads and unscrew the old filters from under the vehicle.

Clean the areas around the mounting heads and screw the replacement filters on. Be sure to follow the manufacturer's instructions when installing a new filter. Open the two shut-off cocks at the filters.

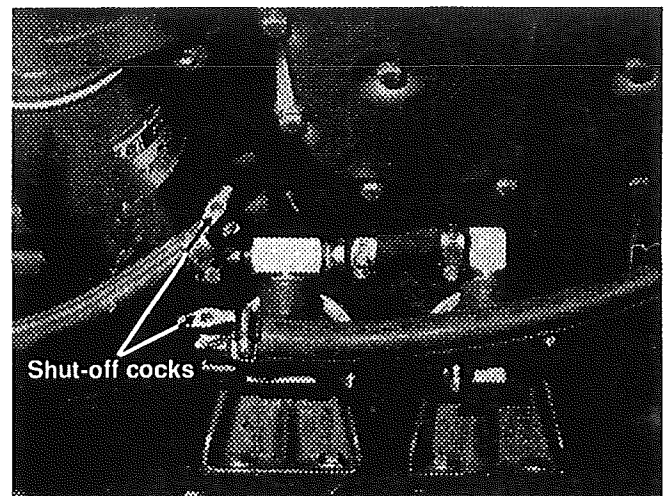

FIG. 16

MA5-0316.IMG

## RADIATOR

The radiator is mounted on L.H. side of vehicle. The inspection of the inside face of the radiator core is made through the condenser & engine compartment door. The radiator is designed to reduce the temperature of the coolant under all operating conditions. It is essential that the radiator core be kept free from corrosion and scale at all times in conjunction with the regular maintenance of the other components of the cooling system.

## RADIATOR SHUTTER

### Description

An air operated shutter assembly is provided on the intake side of the radiator core. The shutter assembly is controlled by an air cylinder (see fig. 17). The air supply to the cylinder is controlled by the shutterstat, which is mounted on the thermostat housing.

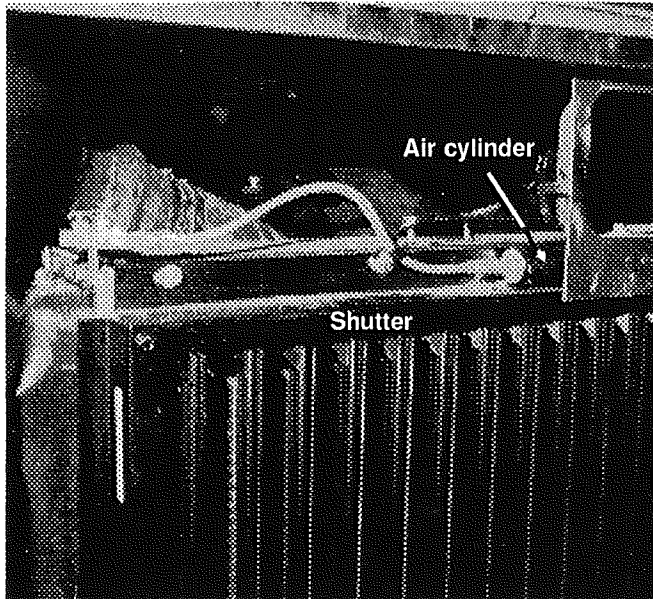

FIG. 17

MA5-0317.IMG

## SHUTTER

### Operation

When the engine coolant temperature reaches 180 °F (82 °C), the shutterstat cuts off the compressed air supply to the radiator air cylinder and the shutter opens, allowing cool air to flow through the radiator fins. When the engine coolant temperature is below the setting of the shutterstat, compressed air is allowed to flow to the radiator air cylinder, closing the shutter.

The radiator shutter can be opened manually by using the following procedure:

1. Close the compressed air supply cock of the shutter air cylinder (see fig. 18).
2. Open the drain cock of the shutter air cylinder.

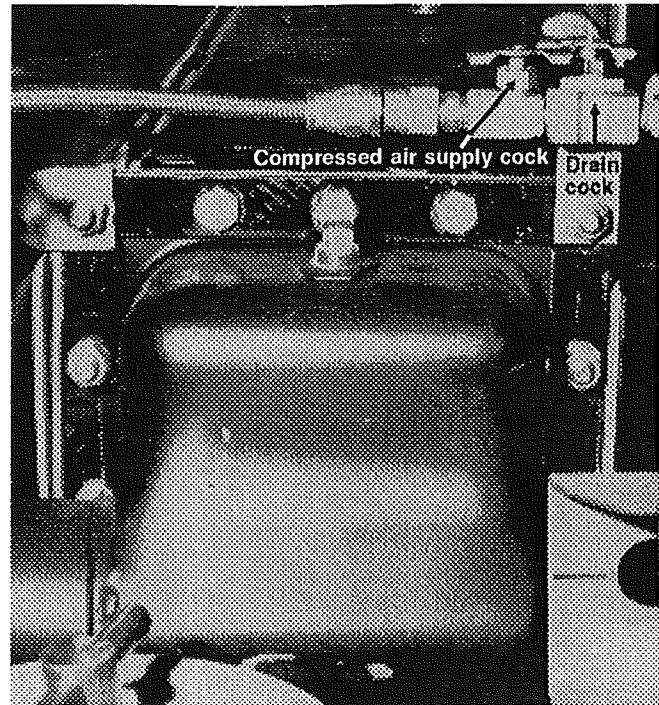

FIG. 18

MA5-0318.IMG

## SHUTTERSTAT

### Description & operation

The shutterstat controls the supply of compressed air to the radiator shutter air cylinder. The shutterstat is mounted on the thermostat housing, condenser side, and can be reached either by the condenser & engine compartment door or the front engine access panel (fig. 19).

When the engine coolant reaches the temperature of the shutterstat setting, the shutterstat cuts off the air supply to the radiator shutter air cylinder, and the shutter opens. When the coolant temperature is below the setting of the shutterstat, air is allowed to enter the radiator shutter air cylinder, closing the shutter.

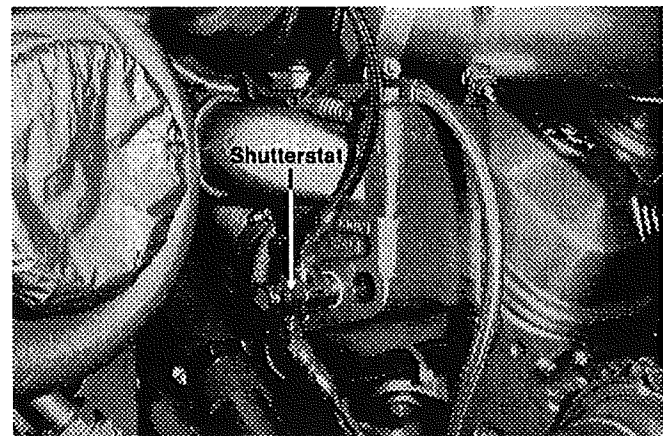

FIG. 19

MA5-0312.IMG

## Maintenance

Remove plug, inject 1-1/2 oz U.S. (45 ml) of special "KYSOR" fluid at each 5000 miles (8 000 km), then ensure that the air exhaust holes are kept free of dirt.

## Removal

Before removing the shutterstat, it is necessary to lower the coolant level in the engine; refer to "Draining cooling system" outlined previously in this section.

1. When the coolant has drained, disconnect the shutterstat air lines and plug or tape them to prevent the entry of dirt.
2. Unscrew and remove the shutterstat.
3. The shutterstat is non-serviceable, and if it is found to be defective, it should be discarded and replaced with a new one.

After replacing the shutterstat, connect the air lines and refill the cooling system. Refer to, "Refilling cooling system", outlined previously in this section.

## RADIATOR VARIABLE SPEED FAN

### Description & operation

The fan drive clutch is a fluid coupling containing silicone oil. Fan speed is regulated by the torque-carrying capacity of the silicone oil. The more silicone oil in the coupling the greater the fan speed, and the less silicone oil the slower the fan speed.

A bi-metallic strip (see fig. 20) regulates the amount of oil entering the fluid coupling, and consequently, the speed of the fan. Both extremities of the bi-metallic strip are held on the fan drive by fasteners. The bi-metallic strip bows outward with an increase in surrounding temperature and allows a control piston to move outward. This outward movement of the control piston allows a greater flow of oil into the fluid coupling, thus increasing the fan speed and engine cooling. As the surrounding temperature decreases, the bi-metallic strip bows inward, thus forcing the control piston inward. This drives the oil out of the fluid coupling, thus decreasing the fan speed.

### Function test

1. Start the engine, allow to run at fast idle until its operating temperature is reached.
2. The radiator being provided with shutter, opening should occur at or before 180 °F (82 °C). Note indicated temperature at which this occurs.
3. With strobe light, note input shaft and output fan speeds as coolant temperature approaches an indicated

195 °F (87 °C). Fan speed should reach 85% of input shaft speed.

**CAUTION:** Indicated coolant temperature should not exceed 200 °F (93 °C) under any condition. Temperatures in excess of 200 °F (93 °C) can cause extensive engine damage.

4. Return engine to idle condition. Allow to cool while running for at least three minutes before shutdown.

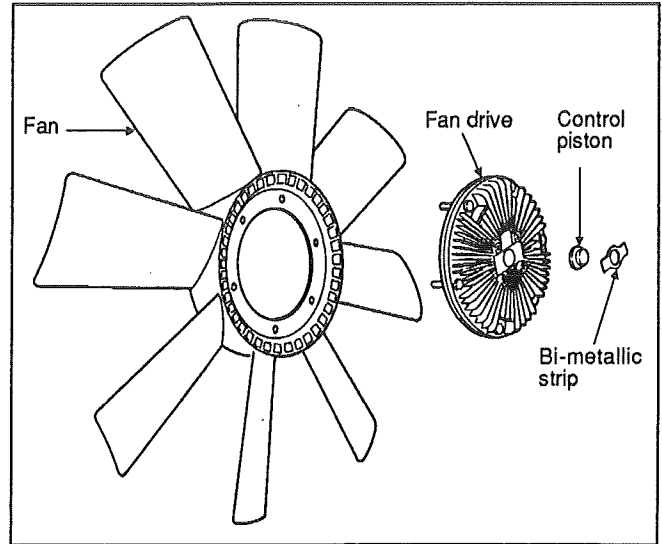

FIG. 20

MA5-0320.IMG

### Maintenance & use

1. Do not clean around drive with steam or high pressure jet.
2. Do not add any fluids or lubricants to the fan drive.
3. Do not restrict fan rotation during engine operation for any reason.
4. Do not operate a drive with a damaged fan assembly. Replace a damaged fan as soon as the fault is noted.
5. Do not disassemble any drive that is still within the warranty coverage period.
6. Immediately investigate and correct any operator complaint involving drive or cooling system performance.
7. When question arise, obtain answers before proceeding. Assistance is available through the authorized Field Sales distributor serving your area.

### 25,000 miles (40 000 km) routine inspection

**WARNING:** Place the "Engine control switch" in the engine compartment, in the "Off" position to prevent accidental starting of the engine.

1. Check security of fasteners holding fan blade assembly to fan drive.
2. Check security of fasteners holding fan drive to fan gear box.

3. Visually examine fan drive, fan blade assembly, shroud, radiator, and surrounding area for evidence of contact between rotating and non-rotating parts.
  4. Check fan transfer belt for fraying, cracking, and proper tension.
  5. Turn fan through at least 360 of rotation. It should turn smoothly, although with some resistance. The amount of resistance varies depending of coolant temperature at the time of engine shutdown. If there is any binding, jerkiness, or if the fan spins freely, the fan drive should be replaced.
  6. Grasp one blade tip and move alternately toward and away from radiator. Allowable fore and aft movement is 1/16" at 10" radius from the centerline. If movement greater than this is evident and it cannot be traced to loose fasteners or fan gearbox wear, the fan drive is defective and should be replaced.
- CAUTION: When making this check, do not use force sufficient to cause deflection of blade assembly as this will give a distorted measurement.**
7. Check fan drive for fluid leakage. It is normal to have very slight misting and dust accumulation around the pin in the center of the front cover. Any other leakage is abnormal and will result in impaired performance.

## FAN GEAR BOX

### Description

The radiator fan is belt driven from the engine crankshaft pulley through a drive shaft and a gearbox. The gearbox is equipped with a dipstick to verify oil level inside the gearbox (see fig. 21).

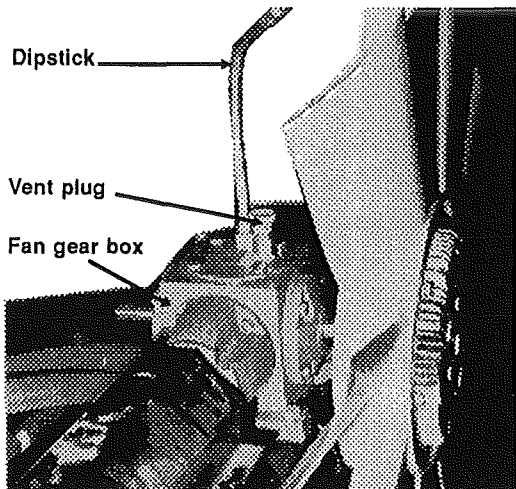

FIG. 21

MA5-0321.JPG

### Maintenance

Under normal conditions, the gearbox should be relubricated at intervals of 2500 hours of operation or six months, whichever occurs first.

## Oil verification procedure

1. Stop engine, and open the condenser and engine door.
2. Remove the dipstick located in the upper L.H. side corner of radiator, and wipe with a clean rag.
3. Reinsert dipstick, then remove it again to check level.
4. If required, add oil (SAE 90 general purpose lubricant) in filler neck with an oilcan until proper level is reached.
5. Replace the dipstick, and close the door.

## FAN TRANSFER SHAFT

### Description

A fan transfer shaft, located in the engine compartment, transmits the power supplied by the pulley to the fan gearbox. The fan transfer shaft assembly is rubber mounted; an universal joint (which can be greased), located on each end of the shaft, enables the linking of the shaft with its component.

### Maintenance

The fan transfer shaft assembly is provided with four (4) grease fittings (see fig. 22). Grease should be added monthly or at every 10,000 miles (16 000 km). To perform maintenance, proceed as follows:

1. Place the "Engine control switch" in the engine compartment, to the "Off" position to prevent accidental starting of the engine.
2. Remove air pressure in the belt tensioner air cylinder by following the procedure given under the heading "Belt replacement" hereafter.
3. Rotate manually the fan transfer shaft pulley in order that the grease fittings be easily accessible with a grease gun.

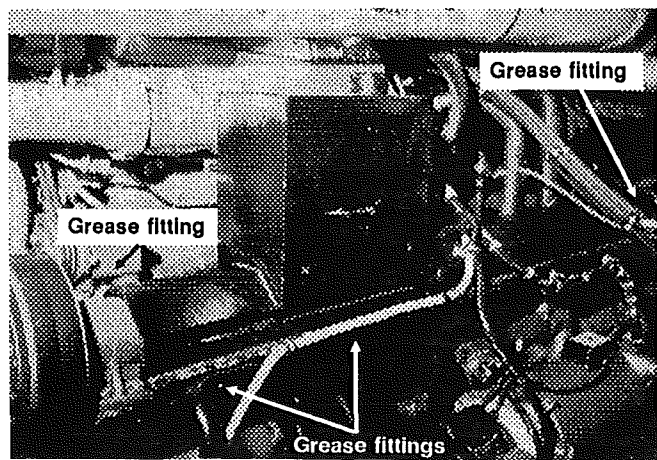

FIG. 22

MA5-0322.JPG

*5000 cycles only high melting point grease should be used there...*

## BELT TENSIONER

### Description

Radiator transfer fan and air conditioning compressor are driven by V belts equipped with an air operated tensioner cylinder (see fig. 23). Access to the air cylinder can be gained through the front engine access panel located in the first baggage compartment.

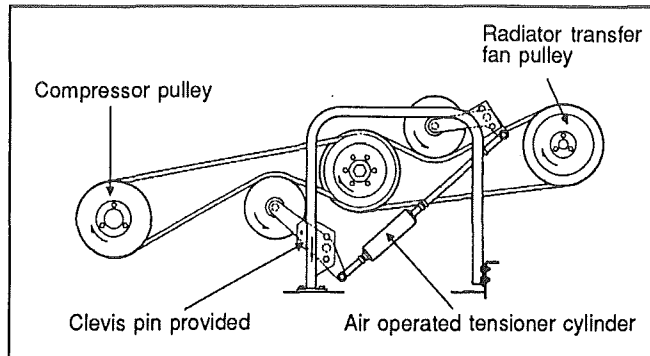

FIG. 23

MA5-0323.JPG

### Adjustment

To maintain the correct tension on the radiator transfer fan and compressor belts, two adjustments are required:

1. Cylinder air pressure
2. Cylinder shaft length

#### Cylinder air pressure adjustment:

With the pneumatic system under normal pressure, connect a pressure gauge in the pressure regulating valve check port located in the upper left corner of the engine compartment (see fig. 24). Reading must indicate 40 psi (275 kPa); if reading is different, set the regulating valve air pressure as follows:

1. Loosen the jam nut on the regulating valve.
2. Turn the set screw until the proper air pressure is obtained.
3. Tighten the jam nut.

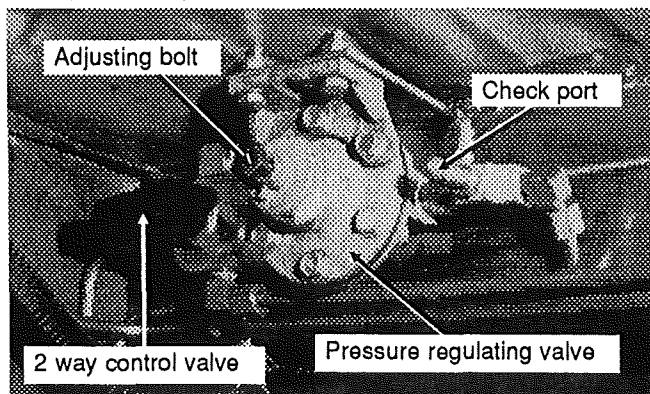

FIG. 24

MA5-1014.JPG

#### Cylinder shaft adjustment:

With the pneumatic system under normal pressure, and the pressure regulating valve set at 40 psi (275 kPa), the shaft length must be  $1\frac{1}{2} \pm \frac{1}{8}$ " (38 mm  $\pm$  3 mm) as shown in figure 23. To perform adjustment, proceed as follow:

1. Loosen the jam nut on the shaft end of the cylinder.
2. Rotate the shaft to obtain the specified length.
3. Tighten the jam nut.

**NOTE:** At compressor or fan transfer belt replacement, it may be difficult to adjust the cylinder tensioner shaft to the specified length. A new drive belt stretches with normal wear, and after approximately 500 miles (800 km), the shaft length should return to  $1\frac{1}{2} \pm \frac{1}{8}$ " (38 mm  $\pm$  3 mm). At the end of this run-in period, the shaft length should be checked and, if necessary, adjusted.

## BELT REPLACEMENT

**WARNING:** Place the "Engine control switch" in the engine compartment to the "Off" position to prevent accidental starting of the engine.

**NOTE:** In case of compressor belt failure, it is possible to operate vehicle without the air conditioning compressor belt by performing the following procedure:

1. Shut off the air supply to the tensioner cylinder by turning the two-way control valve handle (see fig. 24). This will compress the cylinder spring and release the tension on the compressor and transfer belts.
2. Remove front engine access panel located in the first baggage compartment.
3. Rotate pulley tensioner bracket in order that its mounting hole meets the tensioner bracket hole, then lock the system with the provided clevis pin (see fig. 25).
4. Replace the front engine access panel and reset the two-way control valve.

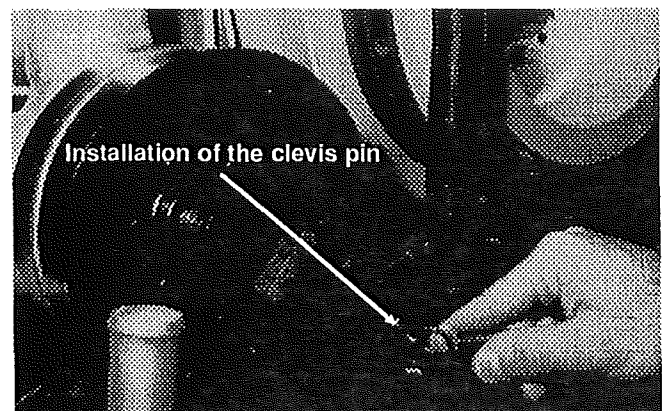

FIG. 25

MA5-0325.JPG

### **Air conditioning compressor belt replacement**

1. Shut off the air supply to the tensioner cylinder by turning the two-way control valve handle (see fig. 24). This will compress the cylinder spring and release the tension on the compressor and transfer belts.
2. Remove front engine access panel located in the first baggage compartment.
3. Remove air conditioning compressor belt and replace by a new one.
4. Refer to previous note under heading "*Cylinder shaft adjustment*".
5. Replace the front engine access panel and reset the two-way control valve.

### **Radiator fan transfer belt replacement**

1. Shut off the air supply to the tensioner cylinder by turning the two-way control valve handle (see fig.24). This will compress the cylinder spring and release the tension on the compressor and fan transfer belts.
2. Remove the front engine access panel located in the first baggage compartment.
3. Remove the compressor belt from the crankshaft pulley.
4. Remove fan transfer belt and replace by a new one.
5. Replace the compressor belt on the crankshaft pulley.
6. Replace the front engine access panel and reset the two-way control valve.
7. Refer to previous note under heading "*Cylinder shaft adjustment*".



## SPECIFICATIONS

### COOLING SYSTEM CAPACITY (Approx.)

Includes heating system . . . . . 58 U.S. gal (220 liters)

### THERMOSTAT

Number used . . . . . 2

Start to open . . . . . 180 °F (82 °C)

Fully open . . . . . 195 °F (91 °C)

### COOLANT FILTER

Number used . . . . . 2

Make . . . . . Perry Filter

Type . . . . . Spin-on

Supplier Number . . . . . PFC-24A

Prévost Number . . . . . 55-0276

### RADIATOR

Make . . . . . Long

Type . . . . . Fins & Tube

Location . . . . . L.H. side of coach

### RADIATOR PRESSURE CAP

Make . . . . . Stant

Supplier Number . . . . . R 12

Prévost Number . . . . . 55-0606

Pressure setting . . . . . 14 psi (96,53 kPa)

### RADIATOR FAN DRIVE

Make . . . . . Schwitzer

Type . . . . . Variable speed

Supplier Number . . . . . 187739

Prévost Number . . . . . 55-0604

### FAN GEAR BOX

Make . . . . . Boston Gear

Ratio . . . . . 1:1

Supplier Number . . . . . R 146-1-J-79

Prévost Number . . . . . 55-0027

**SHUTTERSTAT**

Make . . . . . Kysor  
Supplier Number . . . . . 1047-36000-28  
Prevost Number . . . . . 55-0023  
Opening temperature . . . . . 180 °F (82 °C)

**TEMPERATURE GAUGE (In Engine Compartment)**

Make . . . . . Stewart Warner  
Supplier Number . . . . . 491-BS-72  
Prévost Number . . . . . 56-1011  
Operating Range . . . . . 100-265 °F (40-130 °C)

**TEMPERATURE GAUGE (On Instrument Panel)**

Make . . . . . Datcon  
Supplier Number . . . . . 07177-01  
Prévost Number . . . . . 56-1594  
Operating range . . . . . 100-280 °F (38- 138 °C)

**FAN TRANSFER BELT**

Make . . . . . Gates  
Model . . . . . V80 (358D)  
Type . . . . . V belt  
Supplier Number . . . . . CX75  
Prévost Number . . . . . 50-6601  
Quantity . . . . . 2





# COOLING SYSTEM

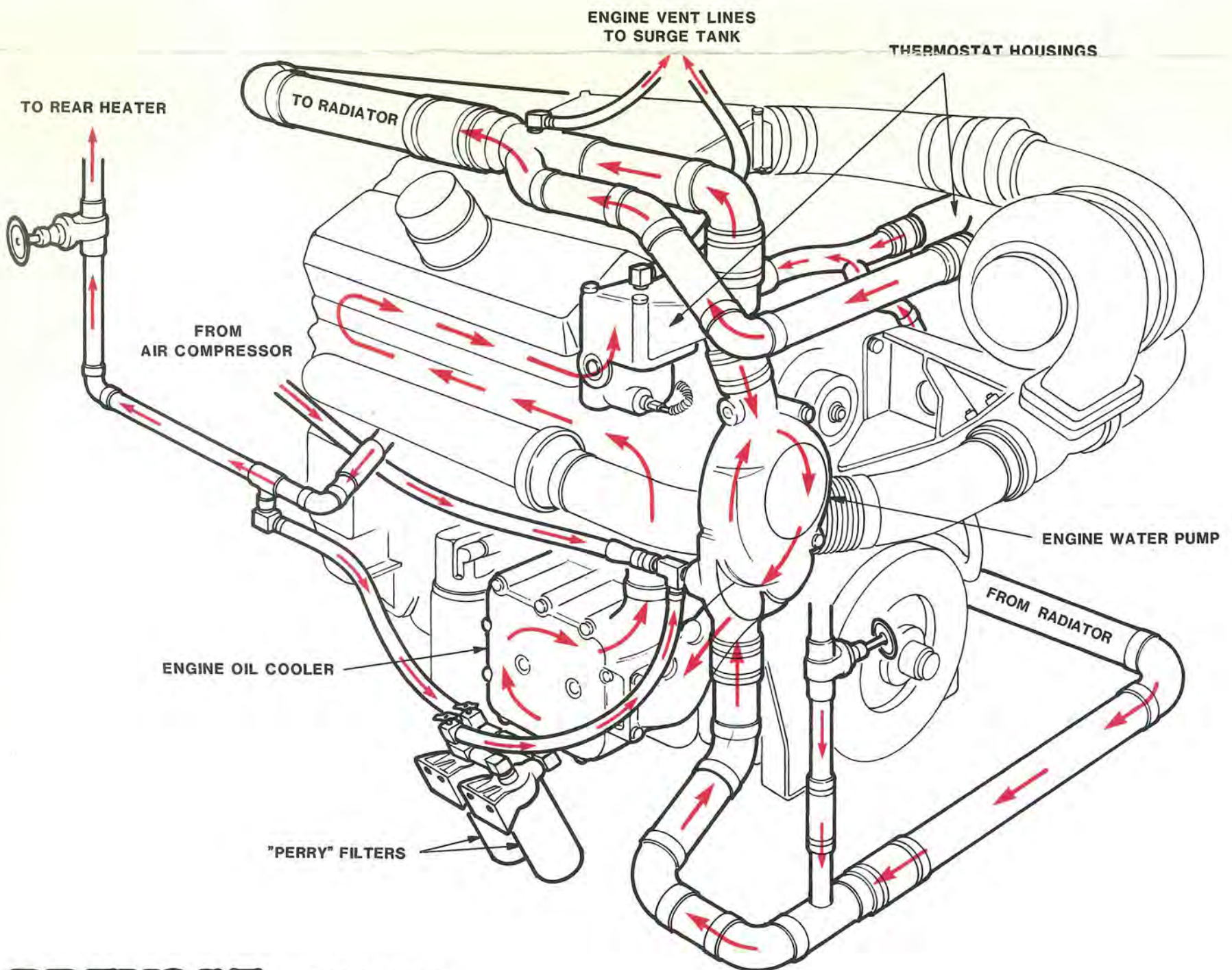
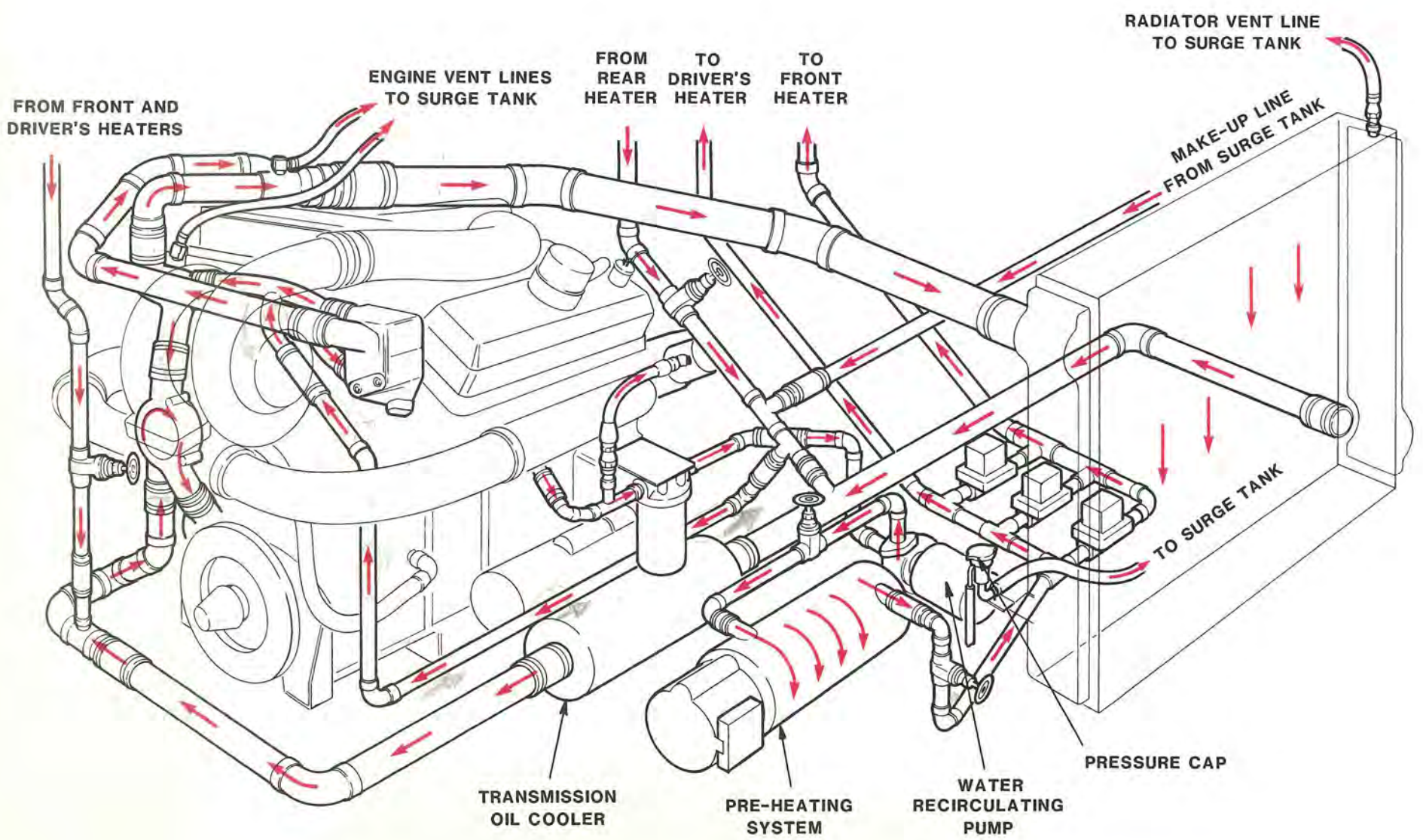

# 04

# EXHAUST SYSTEM

## CONTENTS OF THIS SECTION

MAINTENANCE . . . . .	4-1
MUFFLER REMOVAL/INSTALLATION . . . . .	4-2



# 04 EXHAUST SYSTEM

## MAINTENANCE

Exhaust system should be inspected periodically for restrictions and leaks. Restrictions such as kinked or crimped pipes result in excessive back pressure which can lead to increased fuel consumption, power loss, and possible damage to engine combustion chamber components. Exhaust leaks are commonly the result of loose clamp bolts, corroded pipes, or a punctured muffler. In addition to objectionable noise, a leaking exhaust system could allow toxic gases to enter the vehicle. It is recommended that the exhaust system be inspected as follows:

- At vehicle inspection interval
- Whenever a change is noticed in the sound of the exhaust system
- Whenever the exhaust system is damaged

Damaged or corroded exhaust system components should be replaced without delay.

When operating the engine in a service garage or in a closed area, the exhaust must be vented to the outside. Place the shop vent hose over the exhaust outlet pipe.

**WARNING: Avoid breathing exhaust gases as they contain carbon monoxide which by itself is odorless and colorless, but harmful. Carbon monoxide is a dangerous gas which can cause unconsciousness and can be lethal. If at any time you suspect that exhaust fumes are entering the vehicle, determine and correct the cause(s) as soon as possible.**

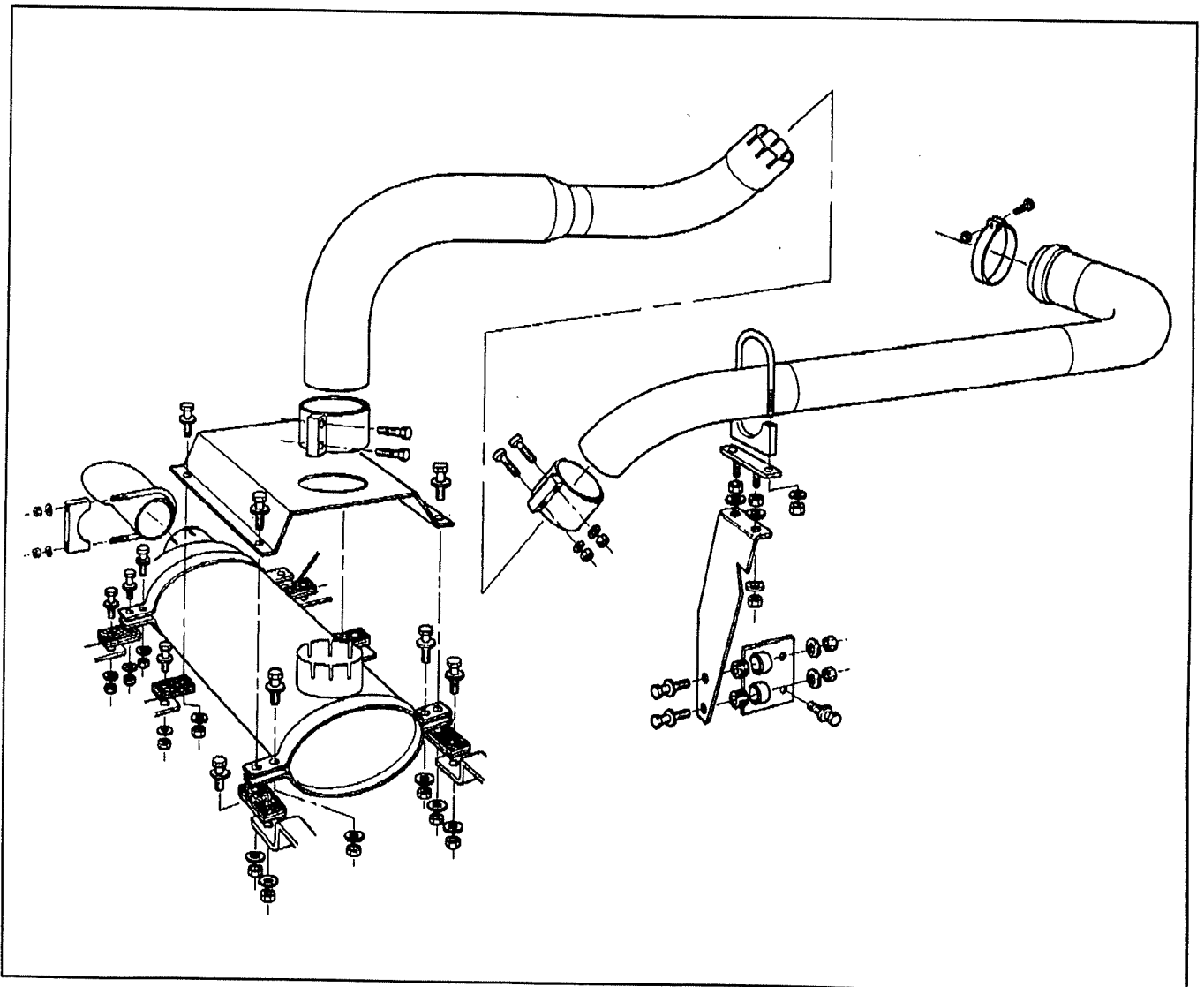

FIG. 1 - Exhaust system

MA5-0401.IMG



## MUFFLER REMOVAL/INSTALLATION

1. Remove bolts and clamp which secure the exhaust pipe to the muffler (see fig. 1).
2. Support weight of the muffler from under the vehicle.
3. Remove the fasteners holding the six (6) rubber mounts to the engine cradle bracket, then remove the muffler from under the vehicle.
4. Remove parts which are fixed to the muffler: U-clamp, tail pipe, heat shield, two (2) muffler retaining clamps, then six (6) rubber mounts. Inspect the parts for damage and replace if necessary; install the parts on the new muffler.
5. Reverse removal procedure to install the muffler on vehicle.

**WARNING: Ensure that muffler and components are cold before performing any work procedure on these parts.**



# 05

# TRANSMISSION

## CONTENTS OF THIS SECTION

DESCRIPTION . . . . .	5-1
TRANSMISSION OIL AND FILTER CHANGE . . . . .	5-1
TRANSMISSION REMOVAL . . . . .	5-2
TRANSMISSION DISASSEMBLY . . . . .	5-3
TRANSMISSION INSTALLATION . . . . .	5-3
TRANSMISSION OIL COOLER . . . . .	5-4
SPECIFICATIONS . . . . .	5-4



## DESCRIPTION

This vehicle is provided with an Allison HT 755 CR electronic controlled automatic transmission (ATEC) (see fig. 1). An input retarder, located between the torque converter and transmission gearing, is also provided to reduce the speed of the vehicle when required. For information about the ATEC transmission, refer to the "Operator's Manual" provided with the vehicle. If detailed instructions for troubleshooting the transmission and its electronic control components are required, refer to the "Troubleshooting Manual # SA 1960" published by Allison Transmission.

**CAUTION:** Internal lubrication of the transmission is inadequate when the vehicle is towed. This is why the propeller shaft or all axle shafts must be removed to avoid transmission damage.

## TRANSMISSION OIL AND FILTER CHANGE

### Intervals

The transmission oil and filter change intervals are determined by severity of transmission service. The intervals given in the lubrication chart (section 19) act as a general guide. More frequent changes may be required when components are subject to high levels of contamination or overheating.

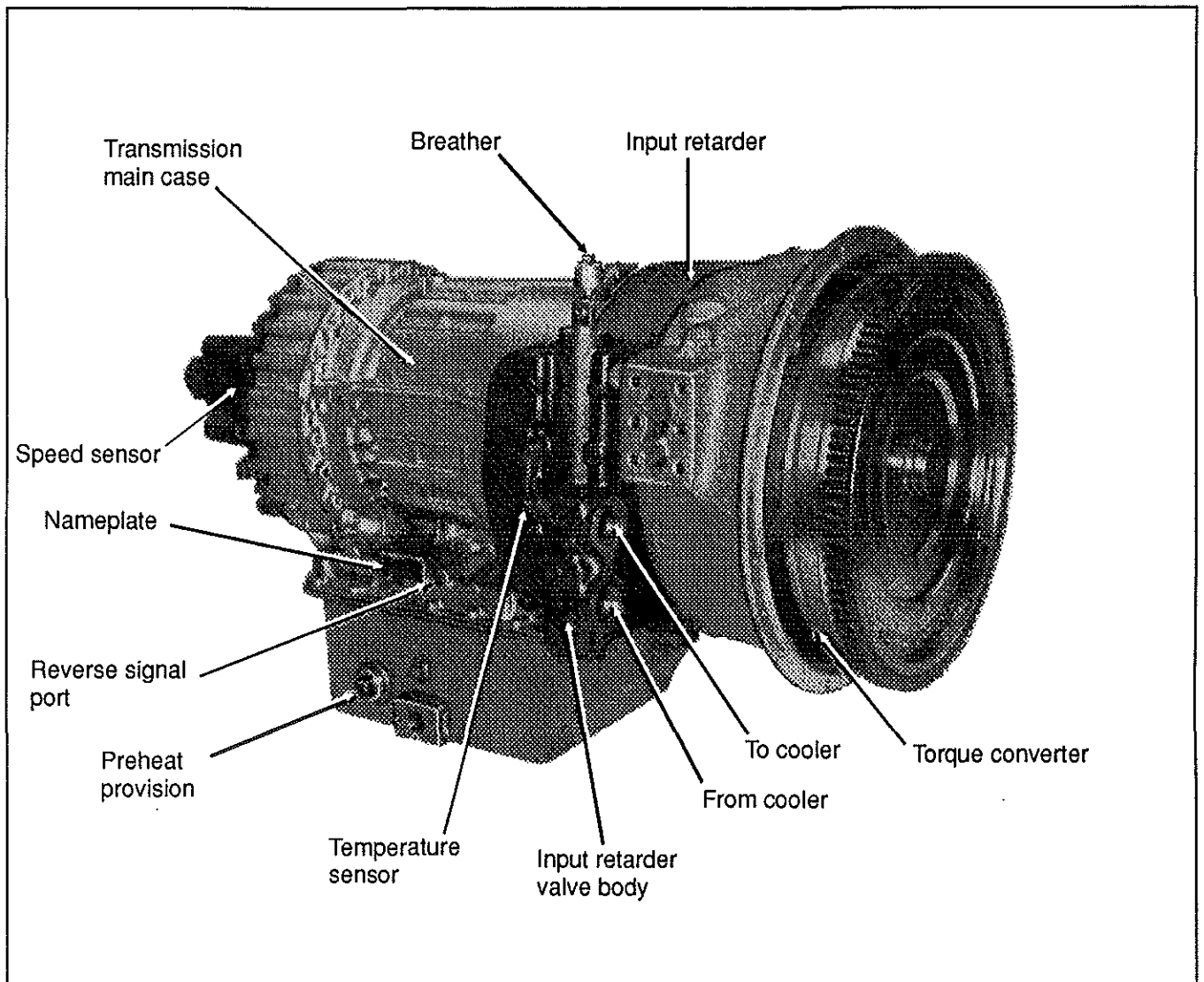

FIG. 1

MA5-0501.IMG

## Procedure

1. Warm up the transmission at its normal operating temperature (160-200 °F (71-93 °C)); this will ensure quicker and better oil drainage. Stop engine and apply parking brake.

2. From under the vehicle, remove the transmission drain plug and allow oil to drain.

**WARNING: Avoid contacting the transmission oil as it can be very hot and cause personal injuries.**

3. Remove the oil filter by turning it counterclockwise, then discard filter.

4. Thoroughly clean dirt and oil from filter base casting with a clean cloth.

5. Coat the new filter gasket with clean transmission oil.

6. Install the new filter and tighten 2/3 of a turn after gasket contact with filter base casting.

7. Inspect the drain plug gasket and replace if necessary. Reinstall the drain plug and tighten to 15-20 ft.lbs (20-27 N.m).

8. Remove the transmission dipstick and pour approximately 33 US quarts (31 liters) of transmission oil (Dexron II or Dexron) into the transmission through the filler tube. Check the oil level using the procedure given in the "Operator's Manual", then add oil as required.

**CAUTION: Do not overfill the transmission. Overfilling can cause oil aeration (milky appearance). If overfilling occurs, drain oil as required to bring it to the proper level.**

## TRANSMISSION REMOVAL

The transmission can be removed without removing the power plant cradle from engine compartment. Follow the procedure hereafter to remove transmission.

**NOTE: To separate transmission from engine when power plant has already been removed from cradle, follow the procedure hereafter and perform only the applicable steps.**

1. Apply parking brake, then set the main battery disconnect switches to the "Off" position.

2. Drain the transmission oil.

**NOTE: For best results, warm to normal operating temperature, remove drain plug and allow oil to drain overnight.**

3. Disconnect the propeller shaft as detailed in section 06 - "Propeller shafts".

4. Remove the muffler and its heat shield (refer to section 02 - "Exhaust system").

5. Remove the transmission oil dipstick and the filler tube.

6. Disconnect from transmission, the main wiring harness connector (C-285) located near the transmission oil filter.

7. Disconnect wiring connector (C-283) from the ATEC speed sensor, then remove its retaining clips.

8. Disconnect wiring connector (C-267) and its retaining clips from the speedometer sensor (located at the rear end of transmission and on the opposite side of the ATEC speed sensor), then remove sensor in order to avoid interference with the exhaust pipe.

9. Disconnect the transmission oil temperature sending unit located on retarder valve body, then remove ties and retaining clips in order to free the wire.

10. Unbolt the bracket holding the coolant pipe to the retarder valve body.

11. Disconnect the air supply line from the retarder air cylinder.

12. Disconnect both transmission oil hoses from the retarder valve body.

**WARNING: A significant amount of oil may drain from the oil lines when they are disconnected from the retarder.**

**NOTE: Hoses must be properly identified prior to their disconnection to ease their reinstallation. Plug all openings to prevent dirt from entering the oil system.**

13. Unbolt all wiring harness retaining brackets from the transmission casing, then position assemblies so they will not interfere with transmission removal.

14. Remove from the engine flywheel housing, the access plug located over the starter, then disconnect the torque converter at the flex disc assembly by removing the 12 retaining bolts through the access opening. To align retaining bolts through the access opening, rotate crankshaft pulley clockwise until bolt is accessible.

**CAUTION: Do not rotate crankshaft pulley counterclockwise to avoid loosening the crankshaft pulley retaining bolt.**

15. Using a safe lifting equipment, which has a minimum capacity of 23,000 lbs (10 455 kg) for the drive axles, 16,000 lbs (7 270 kg) for the front axle and 10,000 lbs (4 545 kg) for the rear axle, raise vehicle in order to gain access under transmission.

16. Using a suitable jack, support adequately rear end of engine.

17. Support the transmission on a suitable removal equipment, then remove the 23 retaining bolts of the torque converter housing.

18. Remove both transmission side bracket bolts retaining transmission to cradle.

19. Remove the 12 bolts (6 on each side) retaining the side brackets to the transmission, then remove brackets to ease transmission removal.

**WARNING: Ensure that rear end of engine is adequately supported when removing transmission. Severe damages and/or injuries may occur if engine is not supported.**

20. Move the transmission away from engine until completely clear of engine.

21. Lower the transmission as necessary to remove it from under the vehicle.

**CAUTION: When removing or reinstalling the transmission, special care must be taken to avoid tilting the transmission forward to prevent the torque converter from falling off the transmission.**

## TRANSMISSION DISASSEMBLY

Refer to "Service Manual # SA 2004" published by Allison Transmission for rebuild or overhaul of the transmission.

**CAUTION: When a transmission failure introduces debris into the oil system, a repeated cleaning and flushing of the transmission oil cooler and lines is recommended.**

## TRANSMISSION INSTALLATION

1. Align one of the twelve bolt holes in the flex plate with the access opening at the front of the engine flywheel housing (over the starter).

2. Install a headless 1/2"-20 guide bolt into one of the flex disc bolt holes in the flywheel. Align the guide bolt with the flex plate hole at the access opening.

3. Lubricate the center pilot boss with molybdenum disulfide grease (Molycote G, or equivalent).

4. Using a suitable transmission jack, lift and push the transmission toward the engine while guiding the pilot boss on the flywheel into the flex plate hub (adapter), and the guide bolt into the hole in the flex plate.

**WARNING: Ensure that rear end of the engine is adequately supported when installing transmission. Severe damages and/or injuries may occur if engine is not supported.**

5. Seat the transmission squarely against the engine flywheel housing. No force is required; if interference is encountered, move the transmission away from the engine and investigate the cause.

6. Align the bolt holes in the converter housing with those in the engine flywheel housing. Install all of the bolts, finger tight, that retain the transmission to the engine.

**CAUTION: The converter housing must be flush against the engine flywheel housing before tightening any bolt. Do not use the bolts to seat the housing.**

7. Tighten four bolts at 90° degree intervals around the converter housing bolt circle. Tighten the remaining bolts. Recommended torque is 45 ft.lbs (61 N.m).

8. Remove the guide bolt through the access opening in the engine flywheel housing. Replace it with a 1/2"-20 X 1" self-locking bolt into the flywheel, finger tight. When all bolts are in place, tighten to 96-115 ft.lbs (131-156 N.m).

9. Install the flywheel housing access plug.

10. Position and secure both side brackets to the transmission using the 12 bolts (6 on each side); tighten to 160-190 ft.lbs (217-260 N.m). This recommended torque applies to grade 8 bolts.

11. Secure the transmission side brackets to the cradle with the 2 bolts, then tighten to 132-170 ft.lbs (180-230 N.m).

12. Connect both transmission oil hoses to the retarder valve body. Tighten fittings to 40-50 ft.lbs (54-68 N.m).

13. Connect the transmission oil temperature sending unit to the retarder valve body.

14. Connect the main wiring harness connector (C-285) to the transmission (near the transmission oil filter).

15. Inspect the drain plug gasket and replace if necessary. Reinstall the drain plug and tighten to 15-20 ft.lbs (20-27 N.m).

16. Remove jacks which secure the transmission and the engine, then lower the vehicle.

17. Connect the air supply line to the retarder air cylinder.

18. Secure the bracket holding the coolant pipe to the retarder valve body.

19. Reinstall the speedometer sensor located at the rear end of the transmission, then connect its wiring connector (C-267) and install retaining clips.

20. Connect the ATEC speed sensor wiring connector (C-283) (located at the rear end of transmission and on the opposite side of speedometer sensor), and install retaining clips.

21. Reinstall the transmission oil filler tube.

22. Secure in place all wiring harness retaining brackets to the transmission casing.

23. Reinstall the heat shield and muffler (refer to section 02 - "Exhaust system").

24. Connect the propeller shaft as detailed in section 06 - "Propeller shafts".

25. Fill the transmission and check oil level using procedure given in the "Operator's Manual".

## TRANSMISSION OIL COOLER

### Description

The transmission oil cooler, located between the engine and the preheating unit, is used to cool the transmission oil by transferring heat to the engine coolant. Hot oil from the retarder is cooled as it circulates around a tube bundle within the oil cooler before returning to the retarder. Coolant from the bottom of the radiator is circulated through the tube bundle where it absorbs heat before returning to the engine.

### Maintenance

The oil cooler and external connections should be inspected at regular intervals, for evidence of coolant or oil leaks. As the oil cooler is factory sealed, only a repeated flushing using a suitable cleaning solvent is recommended when inspection indicates leakage or malfunction, or at time of major transmission repair or overhaul.

## SPECIFICATIONS

### TRANSMISSION

Make . . . . . Allison  
 Model . . . . . HT 755 CR  
 Type . . . . . Five speeds, automatic transmission electronic controls (ATEC)

#### Rating:

Maximum input torque (net installed) . . . . . 1300 ft.lbs (1 762 N.m)  
 Input speed (full load gov.) . . . . . 1900 rpm (min.)  
 . . . . . 2400 rpm (max.)  
 Idle speed in range . . . . . 500 rpm (min.)  
 Lubrication pressure . . . . . 30 psi (207 kPa) @ 1900 rpm

#### Drive:

Direct mount . . . . . Flex disc

#### Torque converter:

Type . . . . . TC 496 single stage, polyphase, 3 elements  
 Lockup clutch . . . . . Automatic in selected ranges

#### Rotation: (viewed from Input)

Input . . . . . Clockwise  
 Output (in forward ranges) . . . . . Clockwise

#### Dry weight:

Standard . . . . . 940 lbs (426 kg)  
 Input retarder package (housing, rotor, valve body) . . . . . 190 lbs (86 kg)



**Main oil pressure:**

Idle 600 rpm in forward or reverse	. . . . .	90 psi (621 kPa) min.
Stall 1200 rpm in forward	. . . . .	140-175 psi (965-1 206 kPa)
Stall 1200 rpm in reverse	. . . . .	235-270 psi (1 620-1 861 kPa)
1500-2000 rpm in all fwd ranges	. . . . .	140-175 psi (965-1 206 kPa)

**Ratios:**

1st	. . . . .	3.69
2nd	. . . . .	2.00
3rd	. . . . .	1.58
4th	. . . . .	1.25
5th	. . . . .	1.00
Rev	. . . . .	9.65
Converter	. . . . .	1.81

**OIL SYSTEM**

Oil type . . . . . Dexron II or Dexron

**Oil filter: (External)**

Make . . . . . A.C. Spark plug  
 Type . . . . . Disposable  
 Supplier number . . . . . 25010643  
 Prévost number . . . . . 57-1457

**Oil capacity: (Approximate)**

System fill (after overhaul) . . . . . 38 US quarts (36 liters)  
 Refill (after drain) . . . . . 33 US quarts (31 liters)

**RETARDER**

Make . . . . . Allison  
 Model . . . . . Input  
 Type . . . . . Hydraulic  
 Absorption capacity . . . . . 375 hp (280 kW)

**OIL COOLER**

Make . . . . . Stewart Warner  
 Type . . . . . Factory sealed  
 Supplier number . . . . . 3-1179A  
 Prévost number . . . . . 55-0598



# 06

# PROPELLER SHAFTS

---

## CONTENTS OF THIS SECTION

DESCRIPTION . . . . .	6-1
MAINTENANCE . . . . .	6-2
DISASSEMBLY OF UNIVERSAL JOINT . . . . .	6-5
CLEANING AND INSPECTION . . . . .	6-6
REASSEMBLY . . . . .	6-6
LUBRICATION . . . . .	6-6
TROUBLESHOOTING . . . . .	6-7
SPECIFICATIONS . . . . .	6-8



## DESCRIPTION

The propeller shafts transmit power from the transmission to the forward/rear differential (axle #3) and from this point to the rear/rear differential (axle #4). Refer to figure 1.

The first propeller shaft is a "Dana 1810", while the other, located between both differentials, is a "Dana 1710". Refer to heading "Specifications" at the end of this section for details. Both are tubular-type shafts provided each with two heavy-duty needle bearing universal joints.

Furthermore, a slip joint on each propeller shaft compensates variations in distance between transmission and differential, or between both differentials. These variations are brought about by the rise and fall of the drive axles as the vehicle passes over uneven surfaces. The slip joints also facilitate the removal of the transmission or drive axles. Refer to figure 2.

Each propeller shaft has a splined yoke at each end for attachment to the transmission and differentials.

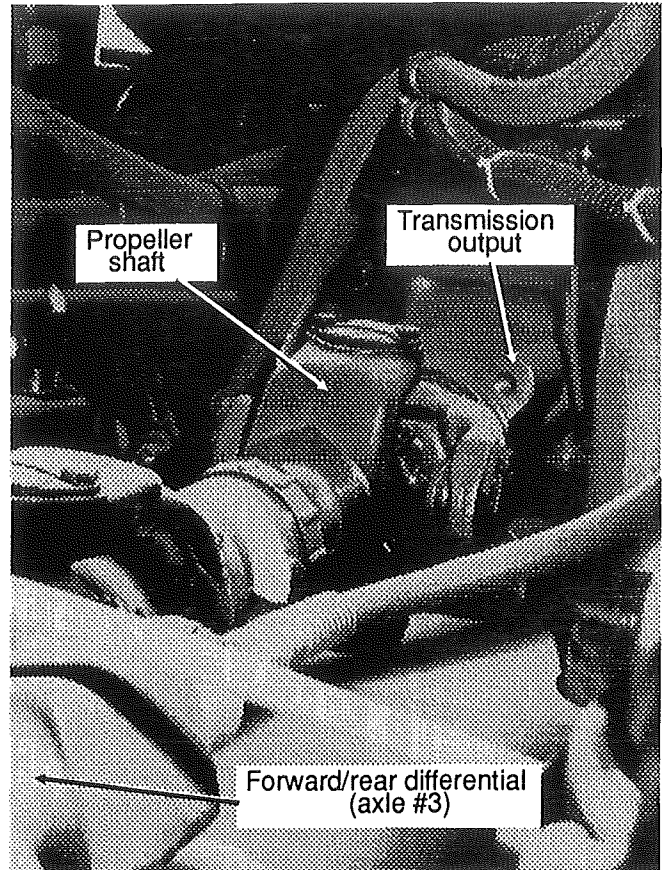

**FIG. 1 - Propeller shaft installation between transmission and forward/rear differential**

MA5-0601.IMG

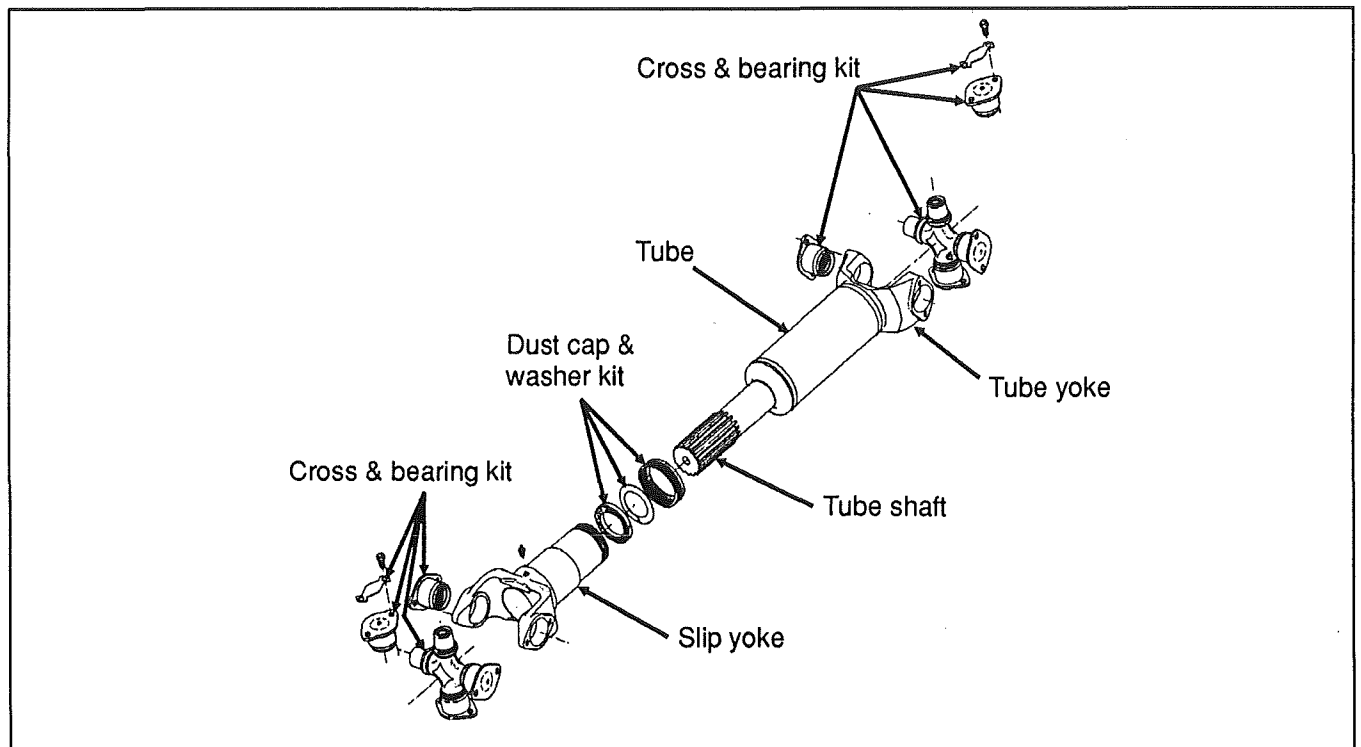

**FIG. 2**

MA5-0602.IMG

## MAINTENANCE

### Lubrication

Universal joints and slip joints of both propeller shafts are provided with lubrication fittings, which should be serviced according to the "Lubrication Chart and Service Check Points" in section 19 (Lubrication) of this manual.

### Inspection

Propeller shaft inspection should be performed during routine servicing, and when detecting a propeller shaft vibration or suspecting a problem. The following inspection steps are recommended when suspecting a propeller shaft problem.

#### 1. Check output/input end yoke looseness.

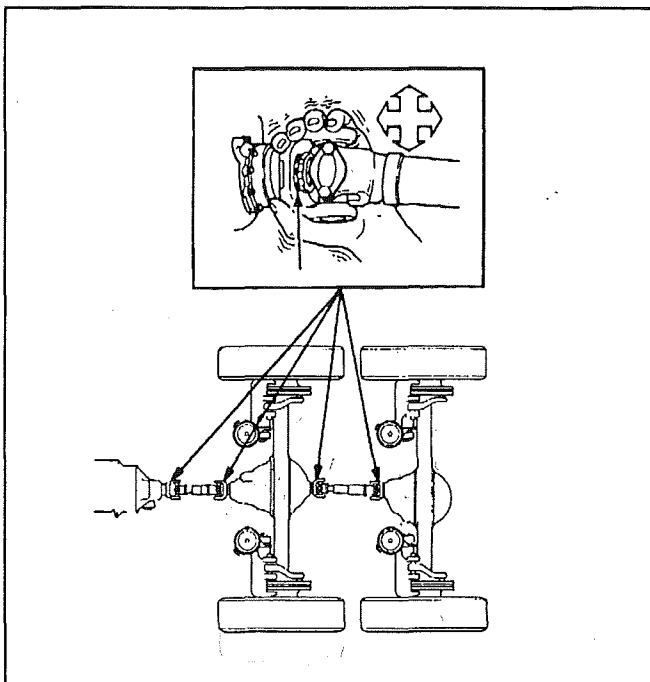

FIG. 3

MA5-0603.IMG

- Check all output/input end yokes on transmission and axles.
- If loose, determine and correct cause.
- If necessary, replace yoke.

#### 2. Check output/Input shafts for radial looseness.

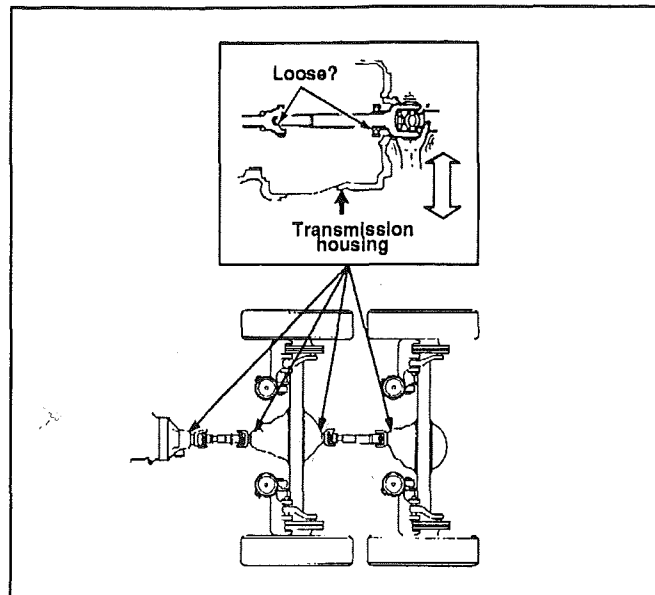

FIG. 4

MA5-0604.IMG

- If yoke ends are tight, check transmission output and axle input and output shafts for radial (up and down, side to side) looseness.
- Check manufacturer's specifications for looseness limits, checking methods, and if necessary, replacement procedures.

#### 3. Check for looseness at ends of U-joints.

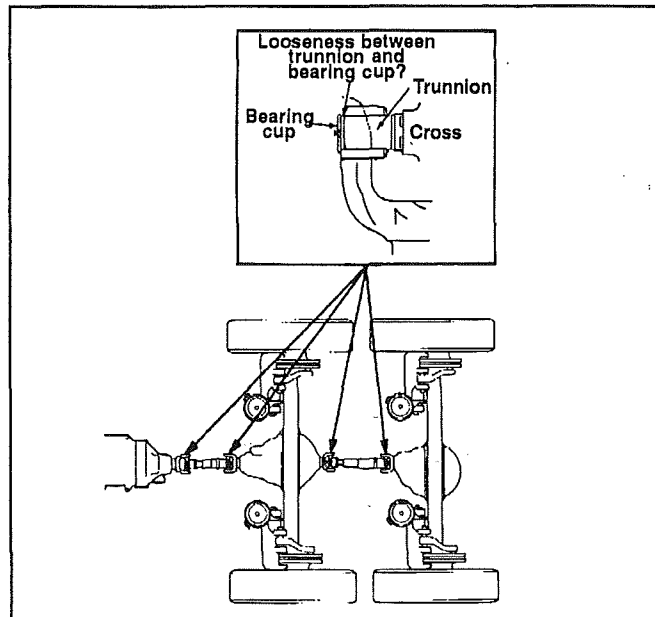

FIG. 5

MA5-0605.IMG

- Check for excessive looseness between bearing cups and trunnion ends of all U-joints.
- Consult manufacturer's specifications for limits.
- Retorque or replace if necessary.

#### 4. Check slip splines for excessive radial looseness.

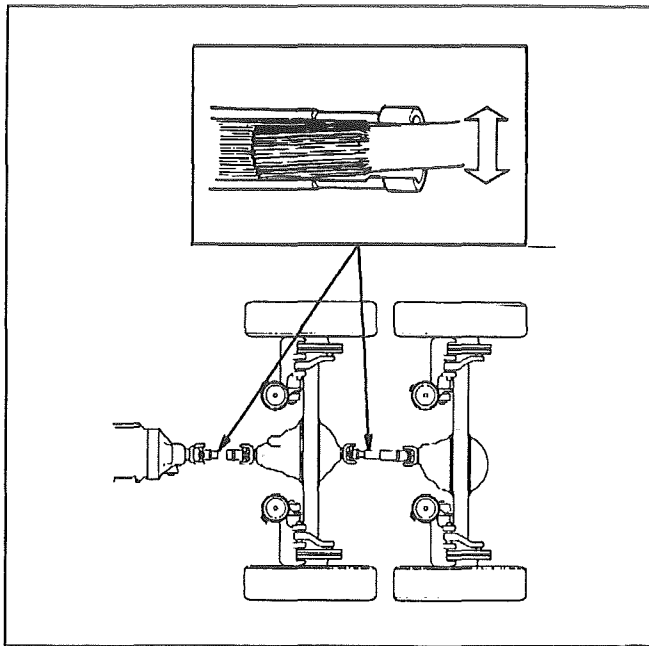

FIG. 6

MA5-0606.IMG

- Check slip splines for any radial looseness.
- If there is any looseness, replace the worn spline members.

#### 5. Check shafts for damage, or foreign material.

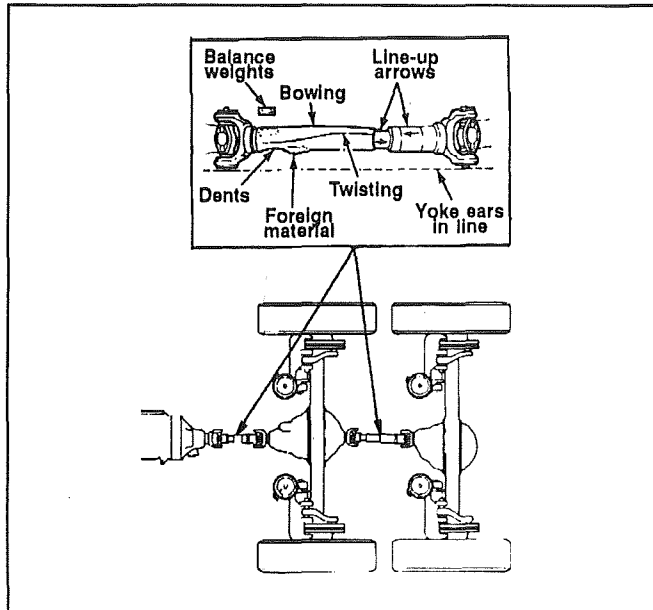

FIG. 7

MA5-0607.IMG

- Check shaft for dents or damage.
- Check to be sure yoke lugs and line-up arrows are properly aligned, and that shaft is not bent or twisted.
- Check to be sure there is no buildup of foreign material such as concrete, asphalt, or undercoating. If there is, remove any material buildup.

**CAUTION:** If shaft is warped or broken, it should be replaced. Welding of broken shafts is not recommended.

#### 6. Check for loose or missing welch plug.

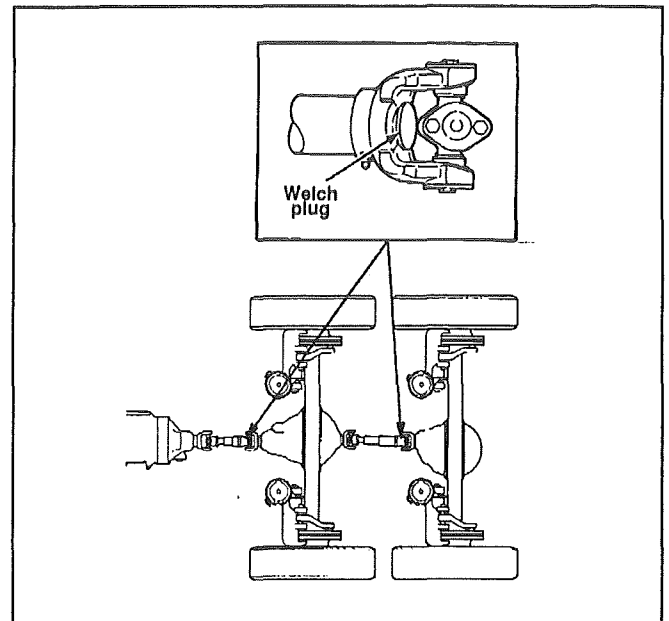

FIG. 8

MA5-0608.IMG

- Check to be sure that welch plug is not loose or missing. If it is, repair or replace it.
- If welch plug is loose or missing, check propeller shaft length to be sure spline plug is not hitting welch plug and knocking it out.

### Explanation of common damages

**1. Cracks:** Stress lines due to metal fatigue. Severe and numerous cracks will weaken the metal until it breaks.

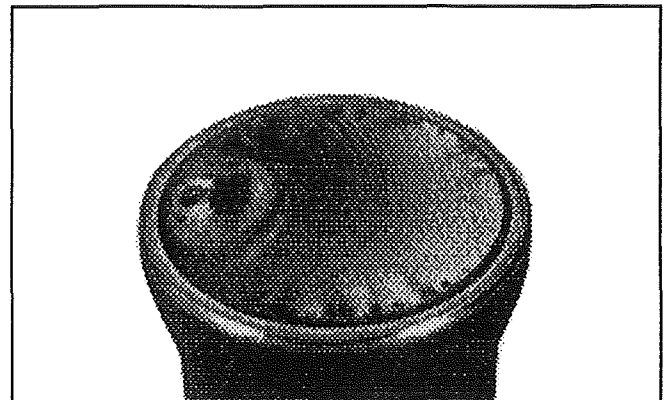

FIG. 9 - Cracks

MA5-0609.IMG

**2. Galling:** Scraping off metal or metal displacement due to friction between surfaces. Commonly found on trunnion ends.

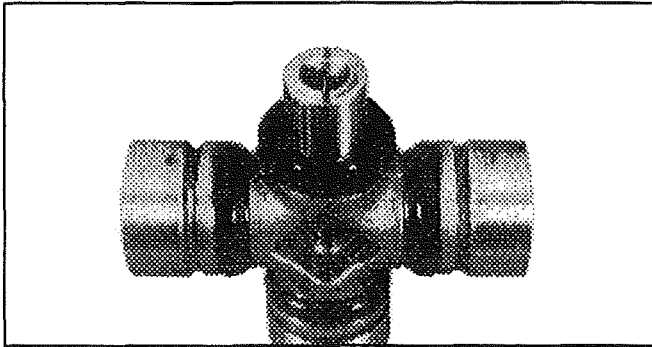

FIG. 10 - Galling

MA5-0610.JPG

**3. Spalling (surface fatigue):** Breaking off of chips, scales, or flakes of metal due to fatigue rather than wear. It is usually found on splines and U-joint bearings.

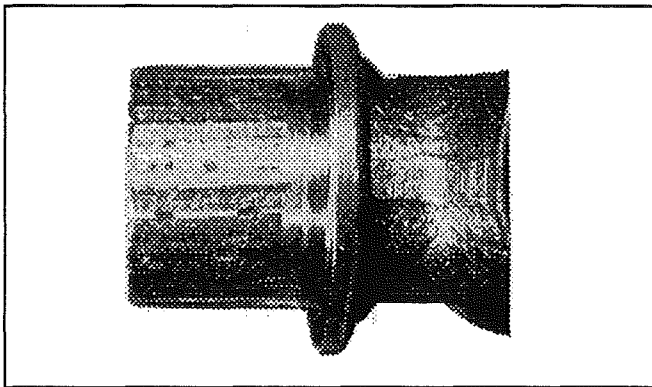

FIG. 11 - Spalling

MA5-0611.JPG

**4. Pitting:** Small pits or craters in metal surfaces due to corrosion. If excessive, pitting can lead to surface wear and eventual failure.

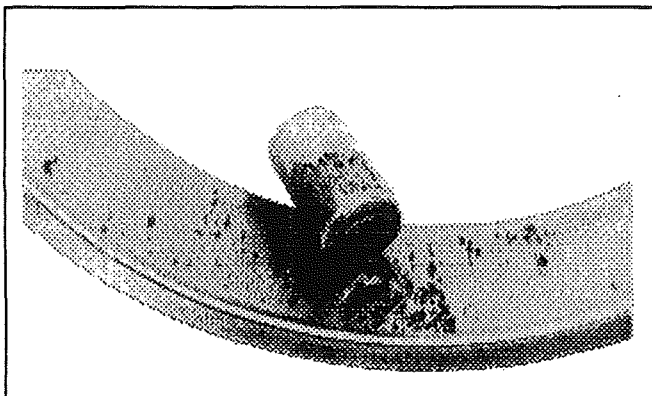

FIG. 12 - Pitting

MA5-0612.JPG

**5. Brinelling:** Surface wear failure due to the wearing of grooves in metal. It is often caused by improper installation procedures. Do not confuse the polishing of a surface (false brinelling) where no structural damage occurs with actual brinelling.

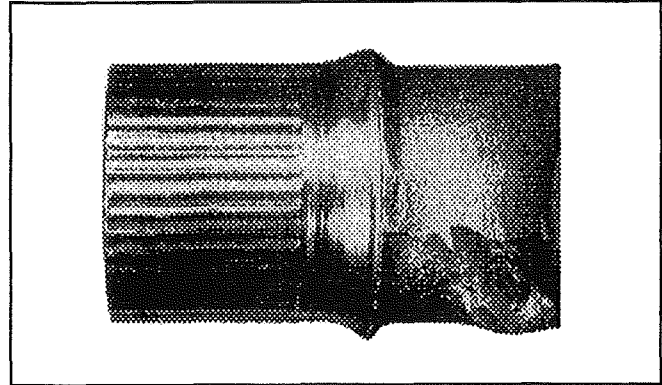

FIG. 13 - Brinelling

MA5-0613.JPG

**6. Structural overloading:** Structural overloading is a failure caused by a load greater than the component can stand. A structural overload may cause propeller shaft tubing to twist under strain or it may cause cracks or breaks in U-joints and spline plugs.

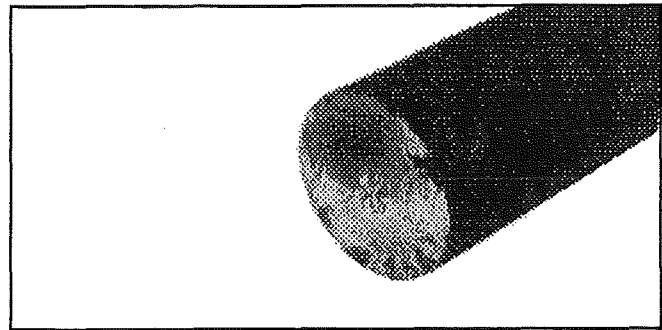

FIG. 14 - Structural overloading

MA5-0614.JPG

## Removal and replacement

**NOTE:** Before attempting to remove propeller shafts, note that slip yoke and shaft are marked with arrows to insure correct alignment of trunnions. If these arrows are not clearly identified, mark yoke and shaft before disconnecting slip joint.

Proceed as follows to remove propeller shafts from vehicle:

1. Disconnect slip yoke from splined yoke at differential and transmission or at both differential extremities (between rear/rear and forward/rear differentials) by removing the two (2) bearings from the splined yoke. To proceed, remove the two (2) bolts retaining the bearing at each end of the splined yoke, as outlined under heading "Disassembly of universal joint", later in this section. Refer to figure 15 for details.



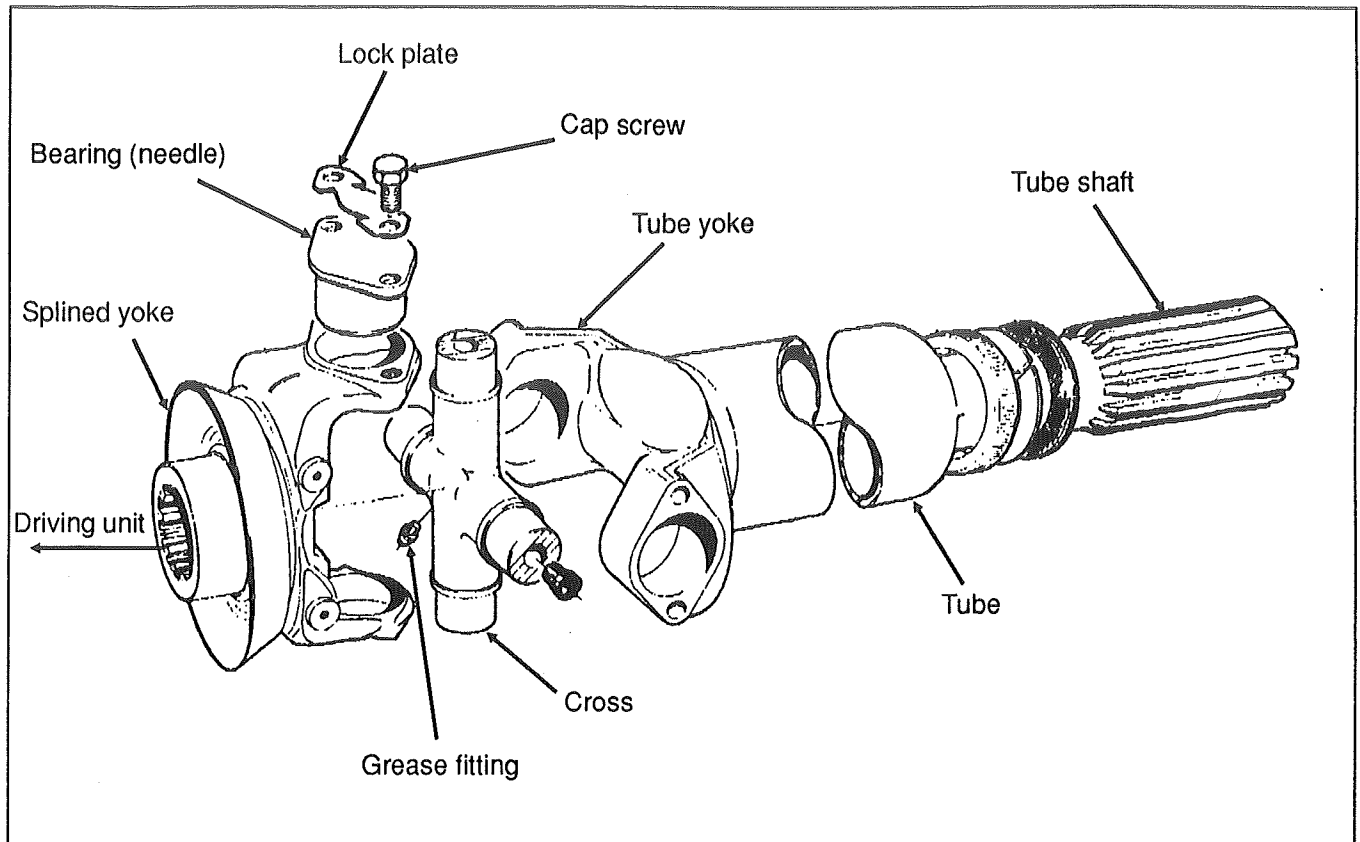

FIG. 15

MA5-0615.IMG

**CAUTION:** Remove bearings slowly in order to retain loose bearing needles in the housing. If one or more needles is lost, replace complete bearing assembly. Never mix needles of a bearing with needles of another bearing.

2. To separate slip yoke from shaft, unscrew dust cap from slip yoke and telescope the propeller together at the slip joint. The shaft can then be removed.

**CAUTION:** In order to prevent entry of foreign material and loss of bearing needles, replace cross bearings to their proper positions and tape them together with the extremity.

3. Reverse removal procedure to replace propeller shaft.

**NOTE:** This procedure is applicable for both propeller shafts on vehicle.

**NOTE:** When replacing needle bearings, be sure to coat them with grease to retain them in their housing.

## DISASSEMBLY OF UNIVERSAL JOINT

1. Use a chisel or a screwdriver and bend tabs of lock plate away from cap screws.

2. Unscrew cap screws and remove lock plate.

3. Remove the needle bearings and retaining cap sub-assembly. Use a large pair of channel lock pliers on retaining cap edges, turn retaining cap and bearing subassembly. In the same time, lift upward to remove the subassembly from the journal trunnion diameter and out of the yoke hole.

4. Turn the joint over and tap with a plastic or rawhide hammer, the exposed end of the journal until the opposite needle bearing is freed. Use a soft round flat face drift approximately 1/32" (.79 mm) smaller in diameter than the hole in the yoke.

**NOTE:** Never use a steel hammer when removing the bearings, and avoid dropping the bearings on the floor, as it may seriously damage the bearings.

5. Remove the journal cross by sliding it to one side of the yoke and tilting it over the top of the yoke lug.

## CLEANING AND INSPECTION

Thoroughly clean grease from bearings, journals, and other parts. Clean all lubricant passages in the journal, and the lubrication fittings. Needle bearing assemblies may be soaked in a cleaning solution to soften hard grease particles. It is extremely important that bearing assemblies be absolutely clean and blown out with compressed air, since small particles of dirt or grit can cause rapid bearing wear. Do not attempt to disassemble needle bearings.

Bearing journal areas should be inspected for roughness or grooving. If light honing does not remove roughness, the entire bearing assembly should be replaced. Excessive wear of the needle bearing is indicated if the needles drop out of the retainer, or if marks are present on the journal bearing surface. In such case, replace bearing assembly.

**NOTE:** Universal joint repair kit are available for overhaul of these assemblies.

Finally, inspect yokes for cracks, wear or distortion.

## REASSEMBLY

Pack needle bearing assemblies with clean grease. Insert one trunnion of the journal into the yoke as far as possible from the inside, and tilt until opposite trunnion clears the yoke and drops into position. Install lubrication fittings and lubricate bearing approximately 1/3 full with the lubricant specified in the "Lubrication Chart and Service Check points" annexed to section 19 "Lubrication".

Insert bearing assemblies from outside of yoke and tap into place with a plastic hammer. Do not use a steel hammer for this purpose. The joints should move freely in the bearings and not bind. If new needle bearing assemblies are not being installed, care should be taken to replace bearing assemblies in the same locations from which they were removed. Install bearing caps, new lock plates, and capscrews. Tighten cap screws to a torque of 33-38 ft.lbs (45-52 N.m), then lock screws by bending lock plate tabs against cap screw heads.

## LUBRICATION

### Universal joints

To insure proper lubrication of all four bearing assemblies on universal joints, it is essential to add lubricant until it appears at all journal cross bearing seals. Refer to figure 16. This ensures removal of dirt particles and other contaminants that may find their way into the bearings and indicate that the bearings are fully lubricated.

Do not assume that bearing cavities have been filled with new lubricant unless flow is noticed around all four bearing seals.

Journal cross seals are designed to relieve. However, if all the seals do not "pop" when being lubed, move the propeller shaft laterally in all four directions, and pull or push on the propeller shaft in the direction opposite to the journal cross seal not relieving, while lube gun pressure is being applied to the alemite fitting. An increase in line pressure may also be necessary.

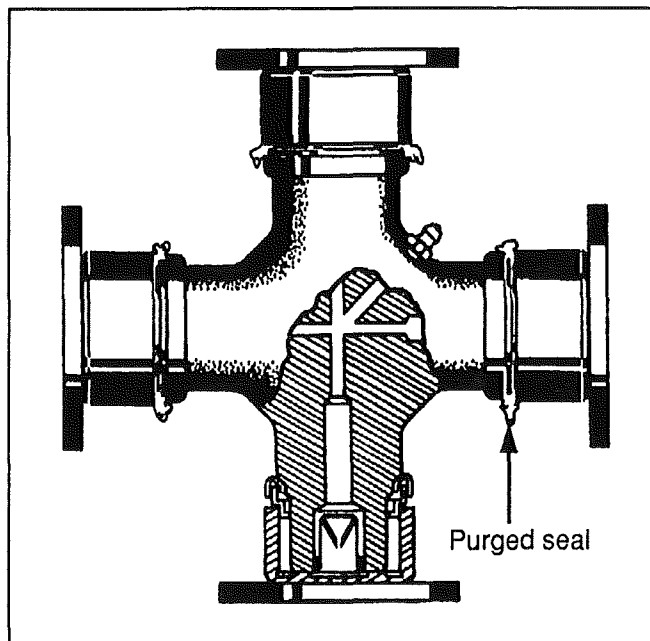

FIG. 16

MA5-0616.IMG

### Propeller shaft assembly

Factory assembled propeller shafts are factory lubricated prior to shipment. When installing spare part replacement assemblies, it is recommended that all universal joints be lubricated after installation of the propeller shaft prior introducing vehicle in service. High quality extreme pressure (EP) grease is recommended for universal joints. Lithium soap base greases meeting NLGI Grade 1 and 2 specifications are preferred. The use of greases that tend to separate and cake should be avoided. Refer to the "Lubrication Chart and Service Check Points" annexed to section 19 "Lubrication" for lubrication intervals and recommended grease.

### Periodic lubrication

Relubrication cycles for propeller shaft universal joints and slip joints vary with operating conditions, such as high ambient temperatures or extremely rough road conditions. In such case, lubrication intervals must be increased (ex. a 5000 mile interval (8000 km) must be divided by 2, thus resulting in a 2500 mile interval (4000 km)).

## TROUBLESHOOTING

Noise and vibration in the drive line often originate from the propeller shaft. Noise and vibration originating in the universal joint and propeller shaft assembly appear only at certain speeds, and usually come and go as the vehicle speed is increased or decreased. Noises produced by the rear axle, on the other hand, are generally present throughout the vehicle's speed range.

When propeller shaft assembly noise and vibration become excessive, the cause should be determined and corrected immediately, since rear axle pinion failure is often a direct result. Propeller shaft noise and vibration often appears to originate in the rear axle.

Common causes of propeller shaft and universal joint vibration are:

- a) Propeller shaft assembly out of balance.
- b) Excessive flange runout or distorted yokes.
- c) Loose yoke nut.
- d) Universal joint yoke misalignment.

If an out-of-balance condition is suspected, the assembly may be tested using a balancing machine. If a balancing machine is not available, the check may be made of each component of the assembly individually on the vehicle. Substitute one component at a time, road testing as each new part is installed. Continue this procedure until the entire assembly meets the required standard of performance.

## SPECIFICATIONS

### PROPELLER SHAFTS

#### Between transmission & forward/rear differential

Make	Spicer Clutch Div. (DANA)
Serie	1810
Collapsed length	13" (33,02 cm)
Slip	.3.38" (8,59 cm)
Splines	16
Prévost Number	58-0047
Supplier Number	.907877-2
U-joint kit, Prévost Number	58-0043
U-joint kit, Supplier Number	.5-281X
Dust cap & washer kit, Prévost Number	58-0052
Dust cap & washer kit, Supplier Number	D8A

#### Between forward/rear differential and rear/rear differential

Make	Spicer Clutch Div. (DANA)
Serie	1710
Collapsed length	18.25" (46,36 cm)
Slip	5.50" (13,97 cm)
Splines	16
Prévost Number	58-0048
Supplier Number	.905545-1
U-joint kit, Prévost Number	58-0031
U-joint kit, Supplier Number	.5-280X
Dust cap & washer kit, Prévost Number	58-0051
Dust cap & washer kit, Supplier Number	D10A





# 07

## FRONT AXLES (1 & 2)

### CONTENTS OF THIS SECTION

DESCRIPTION . . . . .	7-1
LUBRICATION . . . . .	7-1
MAINTENANCE . . . . .	7-2
REMOVAL AND REPLACEMENT . . . . .	7-2
DISASSEMBLY OF FRONT AXLE . . . . .	7-2
PREPARATION FOR ASSEMBLY . . . . .	7-3
ASSEMBLY OF FRONT AXLE . . . . .	7-3
TROUBLESHOOTING GUIDE . . . . .	7-3
FRONT END ALIGNMENT . . . . .	7-3
FRONT END INSPECTION . . . . .	7-3
FRONT WHEEL CAMBER . . . . .	7-3
FRONT WHEEL TOE-IN . . . . .	7-5
FRONT WHEEL CASTER . . . . .	7-6
DRAG LINK TRANSFER LEVER ADJUSTMENT . . . . .	7-6
TRANSFER LEVER CONNECTING ROD ADJUSTMENT . . . . .	7-7
PITMAN ARM . . . . .	7-7
STEERING STOP SCREW ADJUSTMENTS (Axle 1 and 2) . . . . .	7-8
STEERING GEOMETRY . . . . .	7-8
FRONT WHEEL ALIGNMENT SPECIFICATIONS . . . . .	7-9
SPECIFICATIONS . . . . .	7-9
TORQUE SPECIFICATIONS . . . . .	7-9





# 07 FRONT AXLES (1 & 2)

## DESCRIPTION

The H5-60 vehicle is equipped with two front axles mounted in tandem. They are manufactured by Rockwell and each consists of a square beam construction using tempered seamless steel tube center sections, with heat-treated, forged steel knuckle pin ends. Knuckle pin ends are integral parts of the axle center.

Steering knuckles are bushed in the upper and lower pin bosses, so they may turn freely about the pins. Bronze bushings with inner grooves allow grease to flow uniformly to high pressure areas. Grease fittings are installed at both upper and lower knuckle pin bosses.

On both axles, the steering knuckle assemblies are connected to each other by a tie rod, which is threaded at each end and held securely in position by clamps. Right-hand and left-hand threads are provided to simplify toe-in adjustment.

Wheel bearings, air suspension, steering, and brake parts which are mounted on the front axles are described in the applicable sections of this manual.

## LUBRICATION

Perform periodic lubrication according to the recommendations given in Rockwell Field Maintenance Manual No 2 annexed to the end of this section under heading "Greasing procedure". Points which require lubrication on the front axles, are shown on the lubrication and servicing chart annexed to section 19. These points, such as steering knuckle pins, tie rod ends and drag link ends are provided with grease fittings for pressure lubrication.

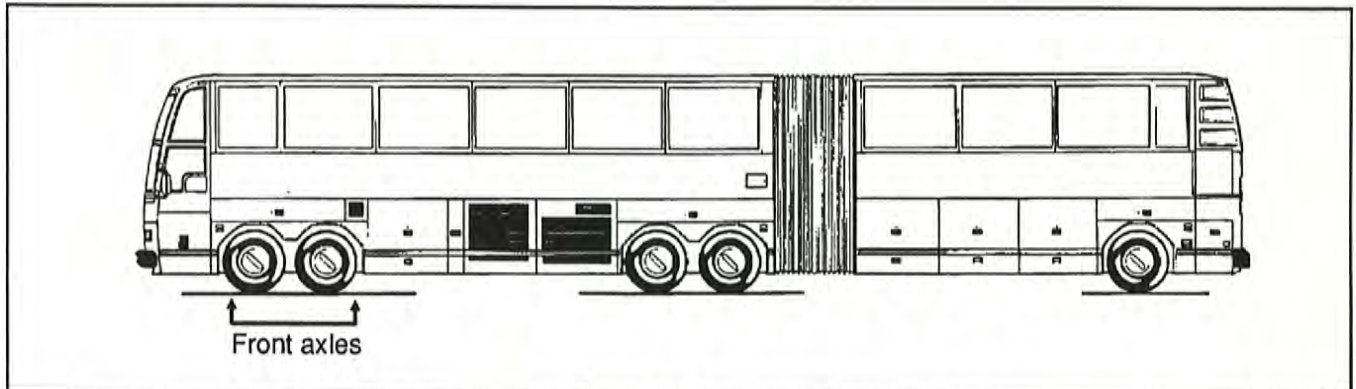

FIG. 1

BUSH560B.IMG

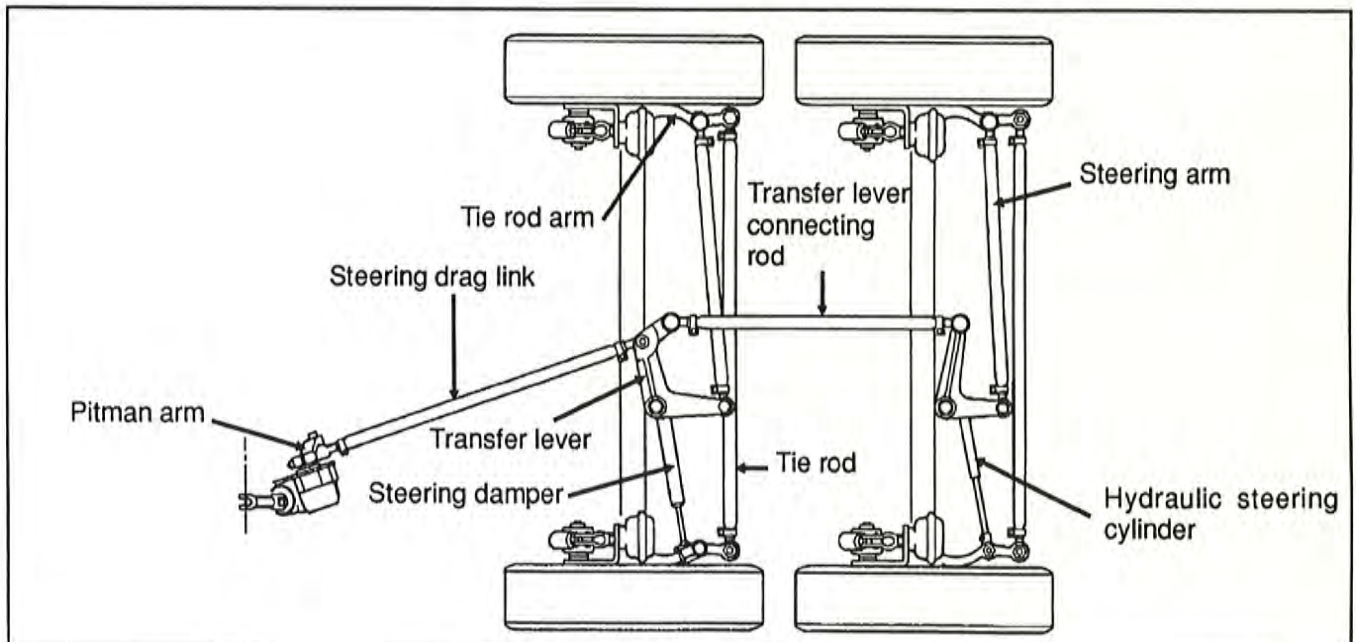

FIG. 2

MA5-1201.IMG

## MAINTENANCE

A periodic inspection of the front axle assembly should be made to check that all bolts are tight, and that no damage and distortion have taken place. Suspension support stud nuts, U-bolt nuts, tie rod arms, steering arm nuts, and stop screws should be checked and tightened if necessary to the torque specifications given at the end of this section. Check also the condition of the steering knuckle pins and bushings. In case of excessive looseness, the bushings and pins should be replaced.

Any looseness in the steering linkage under normal steering loads is a sufficient cause to check immediately all pivot pins for wear, regardless of accumulated mileage. Steering linkage pivot points should be checked each time the axle assemblies are lubricated. Looseness at the steering linkage pivot points can be visually detected during rotation of the steering wheel.

Steering knuckles, knuckle pins, and bushings may be replaced without removing the axles from the vehicle. However, if extensive overall work or straightening of the front axle centers is necessary, the axles should be removed.

## REMOVAL AND REPLACEMENT

The following procedure deals with the removal of the front tandem axle assembly along with the suspension components. The method used to support the axle and suspension components during removal and disassembly, depends upon local conditions and available equipment.

### Removal of axle 1

1. Raise the vehicle by its jacking points on the body (see Section 17 (Body) under heading "*Vehicle jacking points*") until vehicle body is approximately 20" (508 mm) from the floor. Place jack stands under frame. Remove the wheels and tires (if required, refer to section 11 (Wheels, Hubs and Tires).

**CAUTION:** Do not raise vehicle so that the entire weight of the axle is supported by the suspension air bellows and the shock absorber pins, as damage to these components will result.

2. Exhaust compressed air from the air supply system by opening the drain valve of each air reservoir.

3. Install jacks under axle jacking points to support the axle weight.

**WARNING:** To help prevent personal injury caused by the axle rolling off the jacks, jack lifts should be equipped with U-adapters, or similar precautions should be taken.

4. Remove the transfer lever connecting rod and the steering drag link (located between pitman arm and the first transfer lever). Refer to figure 2 for details.

5. Remove cable ties retaining the ABS cables, and disconnect ABS sensor connections near the ABS solenoid control valves.

**NOTE:** When you remove cable ties to ease operation, remember to replace them afterwards.

6. Disconnect the height control valve link from the overtravel lever, then pull down the height control valve lever to exhaust compressed air from the air bellows.

7. Disconnect the hoses from brake chambers.

**NOTE:** Position the air lines so they will not be damaged when removing the axles.

8. Remove sway bar links from suspension supports as outlined in section 14 (Suspension) under "*Sway bar removal*".

9. Remove shock absorbers from suspension supports as outlined in section 14 (Suspension) under "*Shock absorber removal*".

10. Remove the lower, upper, and transversal radius rod supports from subframe as outlined in section 14 (Suspension) under "*Radius rod removal*".

11. Unscrew the two air bellows retaining nuts on each suspension support.

12. Use the jacks to lower axle to the floor. Carefully pull away the jacks and axle assembly from under the vehicle.

### Replacement

Reverse removal procedure to reinstall the axle.

**NOTE:** Refer to section 14 "*Suspension*" for proper tightening torques of suspension components.

### Removal of axle 2

Perform removal procedure of axle 1 along with the following additional steps.

1. Step 5 is not applicable on this axle.

2. Following step 7, disconnect power steering cylinder hoses.

**NOTE:** Identify hoses to ease reassembly procedure.

## DISASSEMBLY OF FRONT AXLE

Disassembly of front axle is explained under applicable heading in "*Rockwell Field Maintenance Manual No. 2*" annexed to this section.

## PREPARATION FOR ASSEMBLY

Preparation for assembly of front axle is explained under applicable heading in "Rockwell Field Maintenance Manual No. 2" annexed to this section.

## ASSEMBLY OF FRONT AXLE

Assembly of front axle is explained under applicable heading in "Rockwell Field Maintenance Manual No. 2" annexed to this section.

## TROUBLESHOOTING GUIDE

A troubleshooting guide of front axle is given in "Rockwell Field Maintenance Manual No. 2" annexed to this section.

## FRONT END ALIGNMENT

Correct front end alignment must be maintained for ease of steering and satisfactory tire life. Road shocks, vibrations, normal stresses and strains on the front end system under average operation can result in loss of front end alignment.

If incorrect front end alignment is suspected, front wheel balance should first be checked to ensure that the difficulties are not originating from out-of-balance front wheels. A check of tire inflation, wheel installation and run-out, wheel bearing adjustment, tie rods and drag link end wear should also be made. Correct front end alignment can only be maintained when parts in the steering knuckle are in satisfactory condition.

## FRONT END INSPECTION

Before checking front end alignment, make the following inspection:

1. Check that vehicle is at normal ride height. Refer to section 14 (Suspension) under heading "Suspension Height Adjustment".
2. Check the tires for proper inflation.
3. Check wheel installation and run-out.
4. Check wheel bearing adjustment.
5. Check tie rod and drag link ends for looseness.
6. Check knuckle pins for looseness.

## FRONT WHEEL CAMBER

### Description

Camber is the amount in inches or degrees that front wheels are tilted outward at top from the vertical plane (see "C" or "B minus A", figure 3). Camber offsets wheel deflection, due to wear of front axle parts, and prevents a "negative" camber condition.

A "negative" camber is an inward ~~or outward~~ inclination of wheels at the top. Camber variations may be caused by wear at the wheel bearings, wheel knuckle bushings, or bent suspension parts. If camber is extreme or unequal between the wheels, improper steering (steering ease is affected by any deviation from proper camber) and excessive tire wear will result. Excessive positive camber results in irregular wear of the tires at the outer shoulders, and negative camber causes wear at the inner shoulders.

### Camber check

Before checking camber, check wear at knuckle pins according to step 1.

1. Jack slightly front of vehicle, pull bottom of wheel outward and take a camber reading. If reading varies more than 1/4 of 1 degree, perform adjustments given in step 2.
2. Adjust the wheel bearings and repeat the check. If reading still varies over 1/4 of 1 degree, replace steering knuckle bushings and knuckle pins as instructed in front axle "Field Maintenance Manual No 2", annexed to the end of this section.
3. Check the wheel run-out as instructed in section 11 "Wheels, Hubs and Tires". If run-out is excessive, straighten or replace wheel(s).
4. With normal weight of vehicle on a level surface, place front wheels on turning plates in a straight ahead position. Attach alignment gauge to each wheel spindle. Record the camber readings for each wheel and compare with specifications. If camber gauge is not available, readings can be taken as shown on "Front wheel alignment chart", figure 3. Place square as illustrated and measure distances "A" and "B". Distance "B" should exceed distance "A" by the specified amount. Camber readings of R.H. wheel should not vary over 3/32" (2,38 mm) from camber readings of L.H wheel. If final camber reading is incorrect, either steering knuckle or axle center is bent.
5. To determine which part is bent, check knuckle pin inclination (K minus J) as shown on "Front wheel alignment chart" in figure 3 or "D". If knuckle pin inclination is correct, the trouble is a bent steering knuckle which should be replaced.

**NOTE: Perform this procedure on both front axles.**

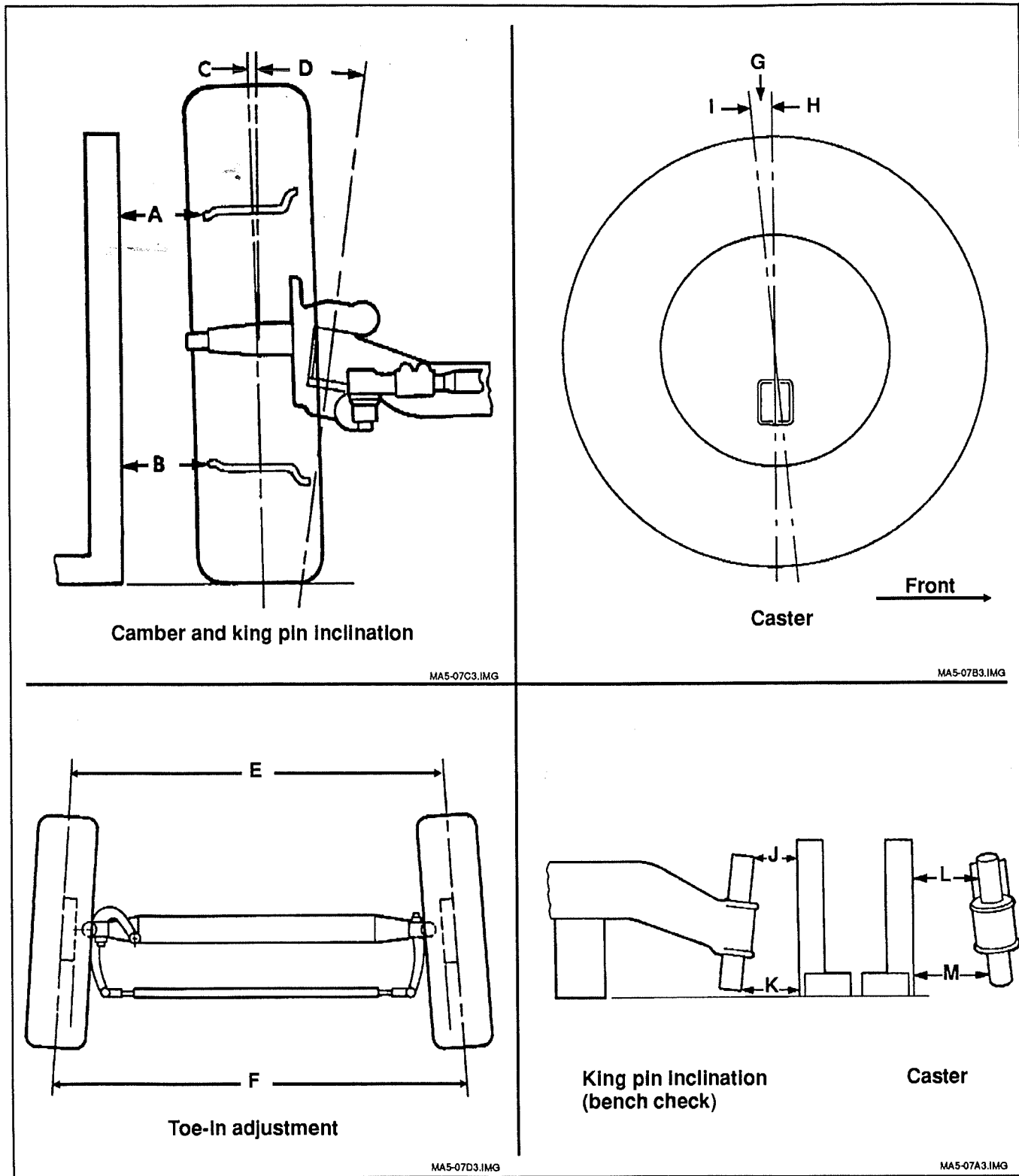

B minus A . . . . . Camber (Inches)  
 C . . . . . Camber (Degrees)  
 D . . . . . King Pin Inclination (Degrees)  
 F minus E . . . . . Front End Toe-In (Inches)  
 G . . . . . Caster angle (Degrees)

H . . . . . Vertical  
 I . . . . . Centerline of King Pin (Knuckle)  
 K minus J . . . . . King Pin Inclination (Inches)  
 L minus M . . . . . Caster (Inches) (measure at front of axle)

Refer to heading "Specifications" later in this section for numerical values.

**FIG. 3 - Front wheel alignment chart**

## FRONT WHEEL TOE-IN

### Description

*Take measurements*

Wheel toe-in is the degree (usually expressed in fractions of an inch) to which the forward part of the vehicle front wheels are closer together than the rear part, measured at hub weight with the wheels in the normal "straight ahead" position of the steering gear. Incorrect toe-in results in excessive tire wear caused by side slippage and also steering instability with a tendency to wander. Toe-in may be measured from center of tire treads or from inside of tires. Measurements at both front and rear of axle (see "E" and "F" on the "Front wheel alignment chart" in figure 3.)

When setting "toe-in" adjustment, the front suspension must be neutralized; that is, all component parts must be in the same relative position when making the adjustment as they will be when in operation. To neutralize the suspension, the vehicle must be rolled forward 12 to 15 feet. By rolling the vehicle forward, all tolerances in the front suspension are taken up and the suspension is then in its normal operating position. Neutralizing the front suspension is extremely important, especially if the vehicle has been jacked up in order to mark the tires, otherwise the front wheels will not return to their normal operating position due to the tires gripping the floor surface when the vehicle jack is lowered.

**NOTE:** "Toe-in" measurements must be taken at the horizontal axis of the wheel.

### Checking and correcting front wheel toe-in

1. Check the camber adjustment and correct if required.
2. Raise the front of vehicle (both axles), then remove the connecting rod between both drag link transfer levers (refer to figure 2).
3. Use paint or chalk and whiten the center area of front tires around the entire circumference.
4. Position a scribe or pointed instrument against the whitened part of each tire and rotate the tires. The scribe must be held firmly in place so that a single straight line is scribed all the way around the tire.
5. Lower vehicle on floor and then move the vehicle back and forth approximately 12 to 15 feet, in order to neutralize front suspension.
6. Position wheels perpendicular to axles by placing pins on axle (see figure 4); measure the distance between pin and rims on each side. The distance should be the same on each side. If not, adjust distance by pushing inside or outside of tires as required. For example, if the distance on one side is 7 1/4" and is equal to 7" on the other side, the final reading should be 7 1/8" on each side.
7. Position trammel bar at rear of tires, adjust pointers to line up with scribe lines and lock in place (scale should be set to zero). Pointers must be raised to spindle height on the tire.

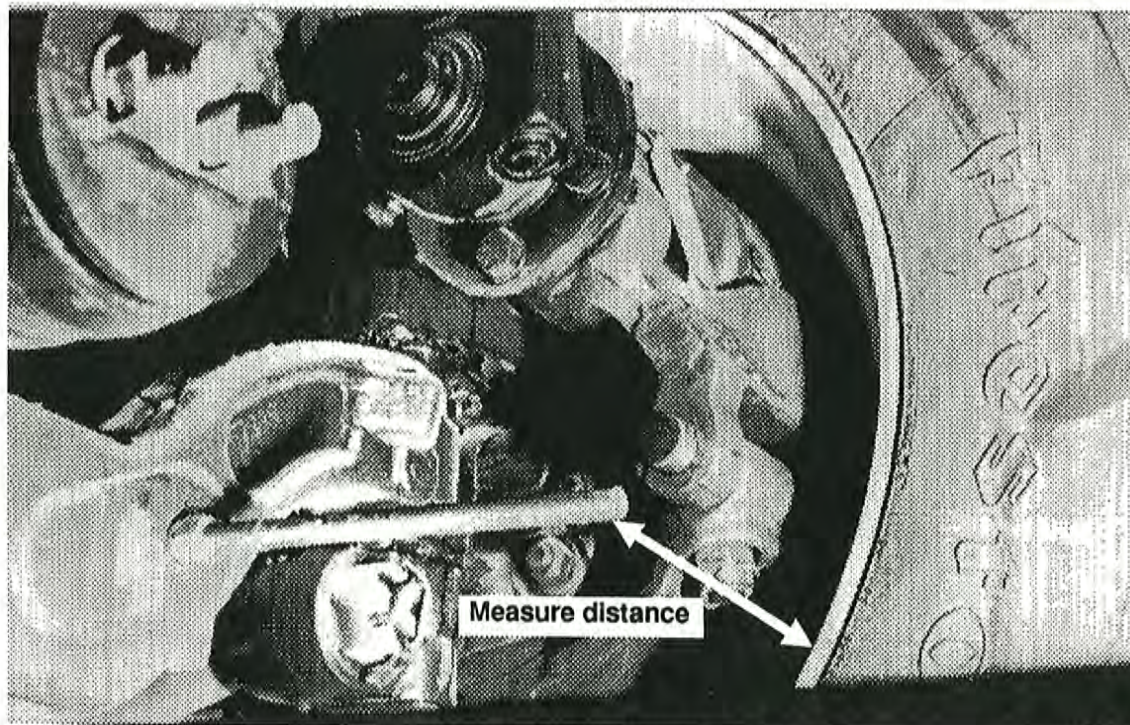

FIG. 4 - Pin Installation on axle

MAS-0903.JMG

8. Position the trammel bar at front of tires. Adjust scale end so that pointers line up with scribe marks.
9. Read toe-in (or toe-out) from scale (see figure 5).

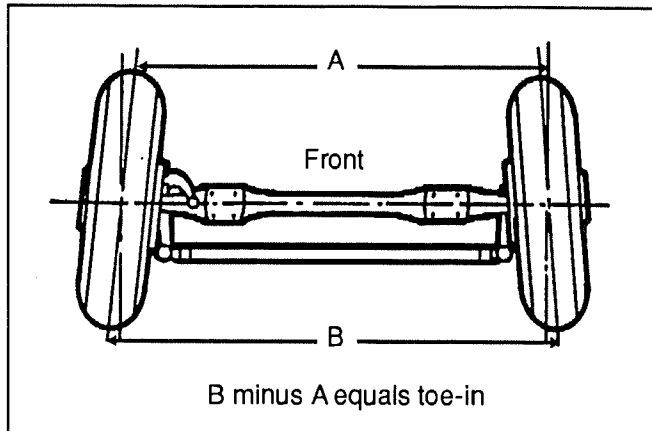

FIG. 5

MA5-0904.JPG

10. These two measurements must be taken at the same height above the floor. Toe-in (or toe-out) is the difference between the measurements taken at the front and rear of the tires (see figure 3). The toe-in measurement should be  $3/32" \pm 1/32"$  ( $2,38 \text{ mm} \pm 0,8 \text{ mm}$ ).

**NOTE:** The same measurements can be taken with a steel tape at spindle height.

11. If an adjustment is necessary, toe-in is adjusted by loosening the clamp bolts on the tie rod ends, and by rotating the tie rod as required until wheels have the proper toe-in.

**NOTE:** The use of a pipe wrench may be necessary when tie rod ends are jammed.

12. With both tie rod ends in the same plane, tighten clamp bolts securely. Refer to heading "Specifications" at the end of this section for correct toe-in and clamp bolt torque. Move vehicle backward and then forward about 12 to 15 feet. This is particularly important when setting the toe-in on vehicles equipped with radial tires.

13. Recheck toe-in setting to make sure it is correct.

**NOTE:** Perform this procedure on both front axles.

## FRONT WHEEL CASTER

### Description

Positive caster is the rearward tilt from the vertical of the knuckle pin. Negative caster is the forward tilt from the vertical of the knuckle pin. This vehicle is designed with positive caster. The purpose of caster angle is to give a trailing effect. This results in a stabilized steering and a tendency of the wheels to return to the straight ahead position after taking a turn.

Excessive caster results in hard steering around corners. A shimmy may also develop when returning to the straight ahead position (pulling out of curves).

Insufficient caster will cause wandering and steering instability. Caster variations may be caused by a bent axle, tilting or distortion of the side suspension supports, damaged radius rod bushings, or unequal tightening of the front and rear suspension support bolts. Incorrect caster must be corrected by replacing the damaged suspension parts. A precision instrument should be used to measure caster.

**NOTE:** The caster of this vehicle is factory set and is nonadjustable. However, if after replacing damaged parts on vehicle or in case of improper caster due to an irregular setting, the caster of axles 1, 2 and 5, can be adjusted by means of shims on the upper radius rods.

## DRAG LINK TRANSFER LEVER ADJUSTMENT

### Description

Before reinstalling the drag link transfer lever connecting rod (rod which joins steering linkage of axle 1 to axle 2), you must proceed with the adjustment of drag link transfer lever angle. This angle should be adjusted to  $90^\circ$  as outlined in the following steps.

### Adjustment

1. Refer to figure 6 before adjusting the angle. Using a square, scribe a reference mark in center across top of steering arm end bolt on transfer lever.
2. With one extremity of the square on mark and the other on axle beam, adjust the angle to  $90^\circ$  by rotating or loosening the steering arm.
3. Tighten and torque steering arm clamps when the proper angle is reached.
4. Repeat this operation on the other front axle.

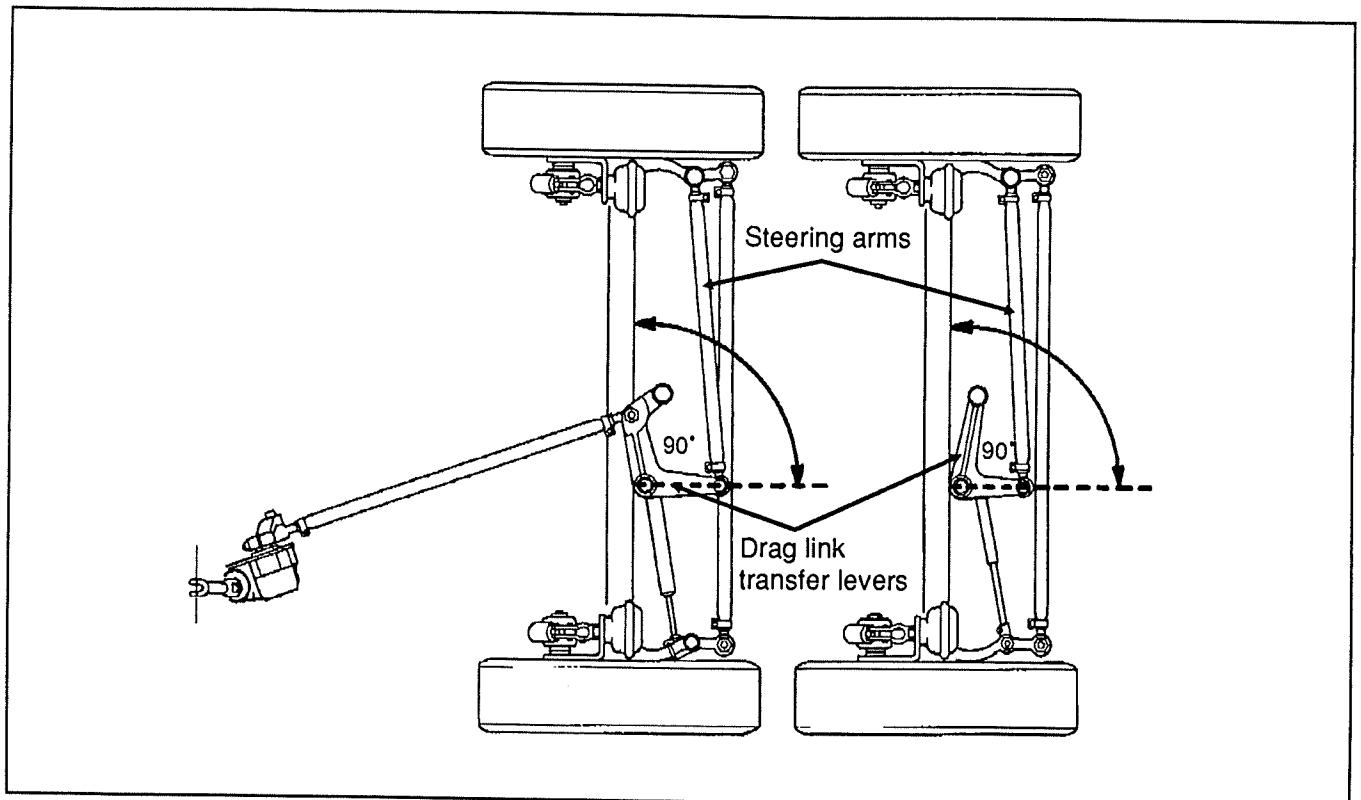

FIG. 6 - Drag link transfer lever adjustment

MA5-0708.IMG

## TRANSFER LEVER CONNECTING ROD ADJUSTMENT

### Description

The final adjustment of the front axles consists in adjusting the connecting rod joining both transfer levers. After proceeding with the drag link transfer lever adjustment on both front axles, these ones have to be assembled with the connecting rod as per the following procedure:

1. Measure the distance from center to center, between both transfer lever connecting rod extremities.
2. Adjust the connecting rod according to this measure.
3. Slide slowly the connecting rod ends. Adjust if required by rotating or loosening the rod. When installed, tighten connecting rod clamps and nuts to the specified torque given at the end of this section under heading "Specifications".

## PITMAN ARM

### Removal (clamp bolt type)

1. Remove cotter pin, nut and washers (2) from drag link ball stud at pitman arm.
2. Disconnect drag link from pitman arm, using jaw style pullers (pressure screw type).

**CAUTION: Do not drive pitman arm on or off pitman shaft as this can damage the steering gear.**

Always wear an approved eye protection equipment when operating pullers.

Heating of components to aid in disassembly is not allowed because it has detrimental effect on axle components and steering linkages.

3. Remove pitman arm clamp bolt nut, washer, and bolt.
4. Check the radial position of the pitman arm in relation to the sector shaft prior removal of pitman arm.
5. Add reference marks to the arm and shaft if necessary to insure correct alignment at reassembly.
6. Remove pitman arm. If necessary, use a jaw style puller (pressure screw type).

**NOTE: A chisel will help you loosen the pitman arm. Use only a puller if you cannot remove manually the pitman arm.**

## Installation

1. Position pitman arm on sector gear shaft with reference marks aligned, while ensuring the clamp bolt groove is matching.
2. Install bolt, washer and nut, then tighten nut to 280-300 ft.lbs (380-408 N.m).
3. Connect drag link to pitman arm. Install washers (2), nut and tighten to 200-220 ft.lbs (272-300 N.m). Afterwards, install a new cotter pin.

## Adjustment

1. Disconnect the drag link from pitman arm, then center steering wheel by dividing in two the total number of steering wheel turns. Scribe a reference mark on steering gearbox at the center previously determined.
2. Using a protractor, check the angle of the pitman arm (refer to figure 7 for details).

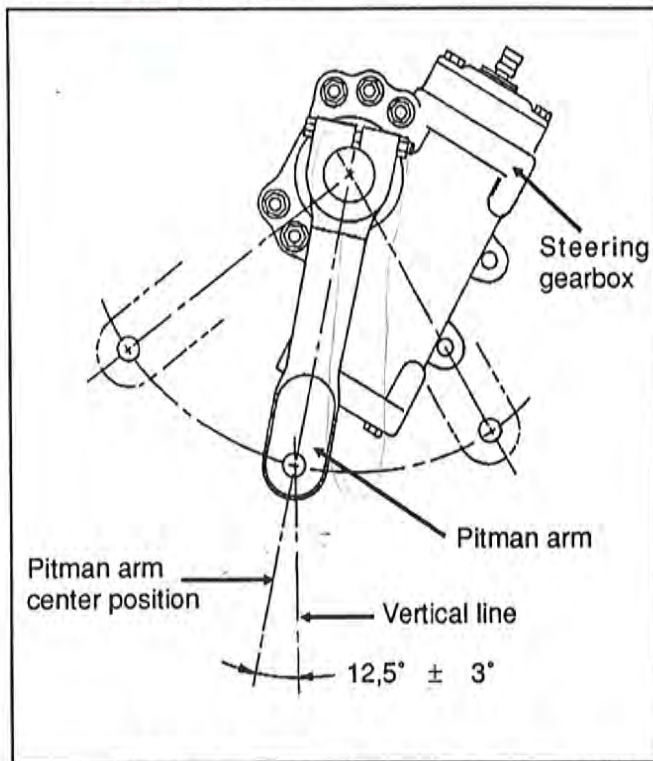

FIG. 7 - Pitman arm adjustment

MAS-0707.IMG

3. The pitman arm should be adjusted to an angle of  $12,5^\circ \pm 3^\circ$  in relation with the vertical axis (facing backwards of vehicle). If not, unscrew and remove bolt, nut and washer. Remove the pitman arm according to the procedure outlined under previous heading "pitman arm removal", then adjust to the proper angle.

**NOTE:** As a reference, each spline on the sector gear shaft affects the angle by  $6^\circ$ .

4. When adjustment is achieved, replace bolt, nut and washer, and torque to 280-300 ft.lbs (380-408 N.m).

## STEERING STOP SCREW ADJUSTMENTS (Axles 1 and 2)

This vehicle is provided with steering stop screws. The steering stop screws are factory adjusted to accommodate chassis design. Steering stop screw adjustments on new vehicles are therefore not required.

The adjustments of both axle steering stops should be checked and corrected any time any part of the steering system is disassembled, replaced, added or adjusted. Adjust the left and right knuckle steering stops to contact when the maximum turning angle of the specific axle is reached, and tighten the locknut afterwards.

Proceed with the following method to check steering stop screw adjustments.

1. Turn the steering wheel to its maximum turning angle.
2. Verify the nearest point of contact of the tie rod with the axle. At this point, measure the distance between axle beam and tie rod.
3. This distance should be  $1/8"$  (3 mm). If not, the steering stop screws must be readjusted. Unscrew the locknut, then loosen or tighten the set screw according to the proper measure. Tighten the locknut afterwards.
4. This must be done for full left and full right turns.

**CAUTION:** On the left side of axle 1, the measure should be taken between the steering damper cylinder and suspension support. The  $1/8"$  (3 mm) distance must be respected in order that the steering damper cylinder do not interfere with the suspension support.

5. As for axle 2, turn axle 1 wheels to their full left and right turns, then adjust the steering stop screws according to axle 1 adjustments. Loosen locknuts, adjust stop screws and retighten locknuts.

## STEERING GEOMETRY

Steering geometry depends on the design of the front end components. Field adjustments are not possible, but a check should be made to see that steering arms, linkage and other parts are properly installed, and are not bent and distorted. Bent or damaged parts should be replaced. The alignment chart includes measurements which can be taken to determine satisfactory condition of the front end parts.



## FRONT WHEEL ALIGNMENT SPECIFICATIONS

Camber (B minus A), degrees	Right 0° ± 3/8°
	Left 3/8° ± 3/8°
Caster (G) Degrees or (L minus M) Inches	Positive 3° ± 1°45'
	-30'
Toe-in (F minus E)	3/32" ± 1/32 / 2,38 mm ± 0,8 mm
Knuckle pin inclination (K minus J), degrees	Right 6°15'
	Left 5°45'
Track	.85.67" (2176 mm)
Pitman arm adjustment angle	12,5° ± 3° (facing backwards of vehicle)

## SPECIFICATIONS

### FRONT AXLE

Make	Rockwell International
Series	FF-952 CA (mounted in tandem)
Wheel Track	85.67" / 2 176 mm
Capacity (each)	13,000 lbs / 5 900 kg

## TORQUE SPECIFICATIONS

Tie rod end stud nuts	160-215 ft.lbs / 218-292 N.m
Tie rod end clamp bolt nuts	.50-65 ft.lbs / 68-88 N.m
Steering arm end stud nuts	160-215 ft.lbs / 218-292 N.m
Tie rod arm nut	550-740 ft-lbs / 748-1006 N.m
Transfer lever connecting rod end stud nuts	160-215 ft.lbs / 218-292 N.m
Transfer lever connecting rod end clamp bolt nuts	.50-65 ft.lbs / 68-88 N.m
Drag link end stud nut (on transfer lever)	160-215 ft.lbs / 218-292 N.m
Drag link end stud nut (on pitman arm)	200-220 ft.lbs / 272- <sup>308</sup> <del>292</del> N.m
Drag link end clamp bolt nuts	.50-65 ft.lbs / 68-88 N.m
Pitman arm nut	280-300 ft-lbs / 380-408 N.m





# 08

## DRIVE AXLES (3 & 4)

---

### CONTENTS OF THIS SECTION

DESCRIPTION . . . . .	8-1
LUBRICATION . . . . .	8-1
MAINTENANCE . . . . .	8-1
REMOVAL AND REPLACEMENT . . . . .	8-2
REMOVAL AND DISASSEMBLY OF DRIVE UNITS . . . . .	8-2
REASSEMBLY OF DRIVE UNITS . . . . .	8-2
PREPARATION FOR REASSEMBLY (CLEAN, INSPECT & REPAIR) . . . . .	8-2
GEAR SET IDENTIFICATION . . . . .	8-3
TANDEM AXLE TIRE MATCHING . . . . .	8-3
TORQUE CHART . . . . .	8-3
DRIVE AXLE ALIGNMENT (AXLES #3 AND #4) . . . . .	8-3
SPECIFICATIONS . . . . .	8-6



## DESCRIPTION

The vehicle is equipped with Rockwell, type SQ-100P tandem drive axles, with front mounted, single-reduction, through drive type units with a two-gear helical transfer train. These units use single-reduction hypoid gears and incorporate bevel type gearing in the main and inter-axle differential assemblies.

These forward-rear drive units are mounted with single wheels, and the standard final drive ratio is 3.55:1.

## LUBRICATION

Lubrication recommendations are given in section 19 "Lubrication" of this manual, under heading "Differential". Additional lubrication information are covered in "Field Maintenance Manual No. 5K" annexed to the end of this section.

## MAINTENANCE

A proper vehicle operation is the beginning of a preventive maintenance, such as good lubrication and good differential use. The most common types of drive axle carrier failures are spinout, shock, fatigue and lubrication. Avoid neglecting these points as it would be the first

step to improper maintenance, expensive repairs, and excessive downtime. The following recommendations will serve you as a guide to prevent possible damage to the differentials.

1. Anticipate slippery conditions. Pre-engage the differential lock (DLO) when wheel spinning is anticipated.
2. Never engage the DLO with one or more wheel(s) spinning.
3. Do not exceed 20 mph (32 km/h) when wheel(s) is(are) spinning.

**CAUTION:** As an example: If the DLO is not in operation, with a wheel spinning and the speedometer indicating 20 mph (32 km/h), the spinning wheel speed is in fact multiplied by four(4), i.e 80 mph (140 km/h), thus resulting in damages to differentials, axle bearings and tires.

4. Always operate the vehicle with the lock control in the "Unlocked" position on normal road conditions.

Inspect the pinion oil seal, axle shaft flange and carrier to housing gaskets for evidence of lubricant leakage. Tighten the bolts and nuts, or replace the gaskets and seals to correct leaks. Maintenance of the axle mountings consists primarily in a regular and systematic inspection of the air suspension units, radius rods and sway bars as directed in section 14 "Suspension".

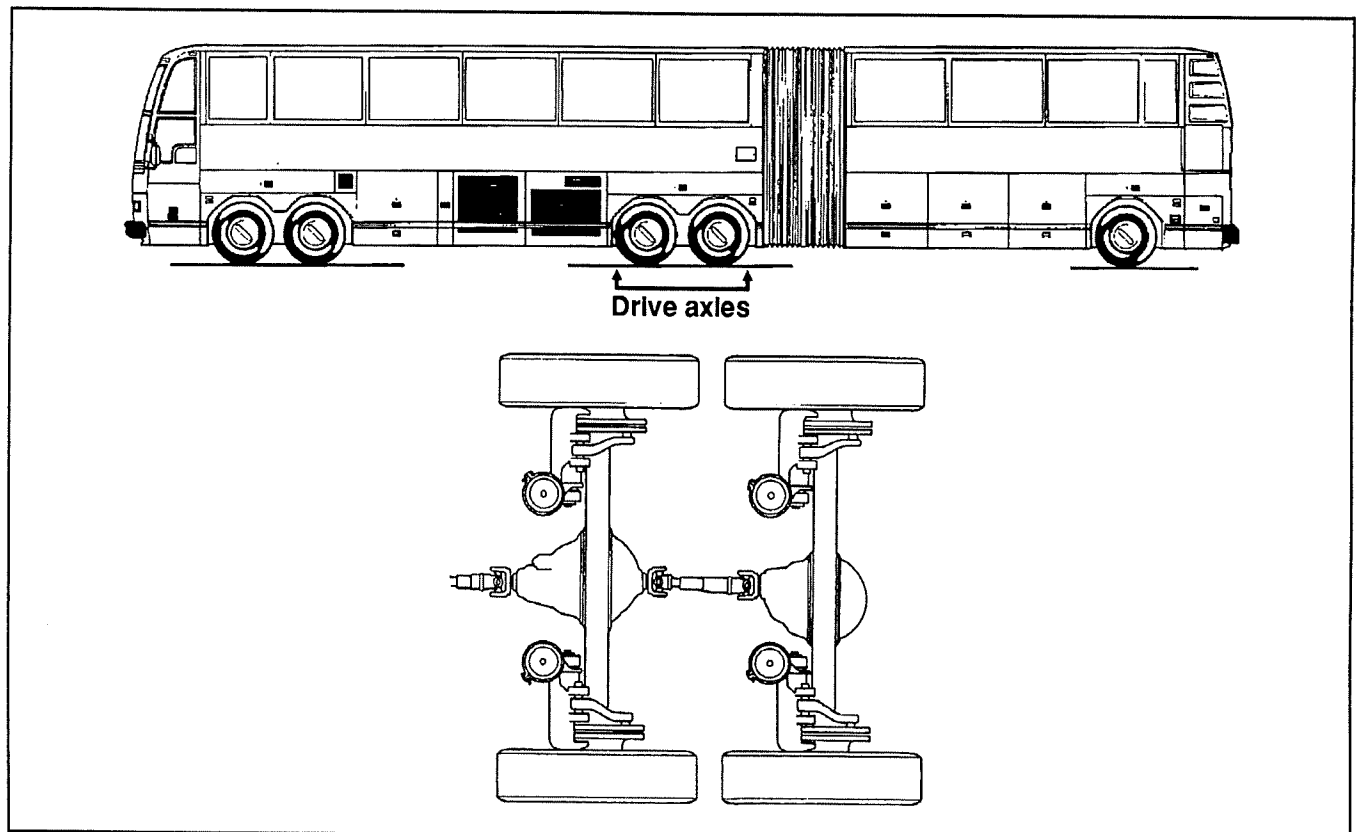

FIG. 1 - Drive axles (3 & 4)

MA5-0601.IMG

## REMOVAL AND REPLACEMENT

The following procedure deals with the removal of the drive axle assembly along with the suspension components. The method used to support the axle and suspension components during removal and disassembly depends upon local conditions and available equipment.

### Removal of axle 3

1. Raise the vehicle by its jacking points on the body (see Section 17 "Body" under heading "Vehicle jacking points") until vehicle body is approximately 20" (508 mm) from floor. Place jack stands under frame. Remove the wheels and tires (if required, refer to section 11 "Wheels, hubs and tires").

**CAUTION: Do not raise vehicle so that the entire weight of the axle is supported by the suspension air bellows and the shock absorber pins, as damage to these components may result.**

2. Exhaust compressed air from the air supply system by opening the drain valve of each air reservoir.

3. Cage brake chamber power springs of axles 3 & 4, then disconnect the hoses routed to the service brake unions (the unions with green hoses) from the ABS valves and the hose routed to the parking brake union (the union with yellow hoses) from valve R14. Position the air lines so they will not be damaged when removing the axles.

4. Disconnect the hose routed to the inter-axle differential lock shift cylinder on the forward unit (the union with a black hose).

**NOTE: Identify all hoses to ease reassembly procedure.**

5. Disconnect propeller shafts (the one between the transmission and the forward/rear differential and the other between the forward/rear and rear/rear differentials) as directed in section 6 "Propeller shafts" of this manual.

6. Install jacks under the axle jacking points to support the axle weight.

7. Disconnect both height control valve links from the overtravel lever, then pull down the height control valve levers to exhaust compressed air from the air bellows.

8. Remove sway bar links from suspension supports as outlined in section 14 under "Sway bar removal".

9. Remove shock absorbers from suspension supports as outlined in section 14 under "Shock absorber removal".

10. Remove the lower and upper radius rods from their support on subframe as outlined in section 14 under "Radius rod removal".

11. Unscrew the two air bellows retaining nuts on each suspension support.

12. Use the jacks to lower the axle to the floor. Carefully pull away the jacks and axle assembly from under the vehicle.

**CAUTION: Be careful not to damage the air dryer when removing axle 4.**

### Replacement

Reverse previous removal procedure to reinstall axle.

**NOTE: Refer to section 14 "Suspension" for proper tightening torques of suspension components.**

### Removal of axle 4

Use removal procedure of axle 3 along with the following additional steps:

1. After step 3, remove cable ties retaining the ABS cables and disconnect ABS sensor connections near the ABS solenoid control valve on R.H. side, and the connection attached to the service brake hose on the L.H. side.

**NOTE: When you remove cable ties to ease operation, remember to replace them afterwards.**

2. Step 4 is not applicable for axle 4.

3. At step 5, remove only the propeller shaft located between the forward and rear differentials.

### Replacement

Reverse previous removal procedure to reinstall axle.

## REMOVAL AND DISASSEMBLY OF DRIVE UNITS

Remove and disassemble drive units as explained under applicable headings in "Rockwell Field Maintenance Manual No. 5K" annexed to this section.

## REASSEMBLY OF DRIVE UNITS

Reassemble drive units as explained under applicable headings in "Rockwell Field Maintenance Manual No. 5K" annexed to this section.

## PREPARATION FOR REASSEMBLY (CLEAN, INSPECT & REPAIR)

Preparation for reassembly is explained under applicable headings in "Rockwell Field Maintenance Manual No. 5K" annexed to this section.

## GEAR SET IDENTIFICATION

Gear set identification is explained under applicable headings in "Rockwell Field Maintenance Manual No. 5K" annexed to this section.

## Adjustments

Adjustments are explained under applicable headings in "Rockwell Field Maintenance Manual No. 5K" annexed to this section.

## TANDEM AXLE TIRE MATCHING

Tandem axle tire matching is explained under applicable headings in section 11 (Wheels, hubs and tires) of this manual.

## TORQUE CHART

A differential torque chart is given in "Rockwell Field Maintenance Manual No. 5K" annexed to this section.

## DRIVE AXLE ALIGNMENT (AXLES #3 AND #4)

### Description

The axle alignment consists in aligning the axles according to the frame. The axles must be perpendicular to the frame and both must be parallel to each other. Axles #3 and #4 are provided with setscrews to achieve a perfect alignment. Drive axle alignment is factory set and is not subject to any change, except if vehicle has been damaged by an accident or if there is excessive wear on suspension components.

**CAUTION:** If this setting is altered significantly, the differential and the universal joint angles will be modified, and will cause excessive tire wear and/or steering wanderings.

If axles have been removed for repair or servicing and are replaced without changing the suspension supports, the axle alignment is not necessary. However, if the suspension supports have been replaced, proceed with the following instructions to verify or adjust the drive axle alignment.

**NOTE:** If only one of both drive axles has been removed, this axle tracking can be adjusted according to the other axle.

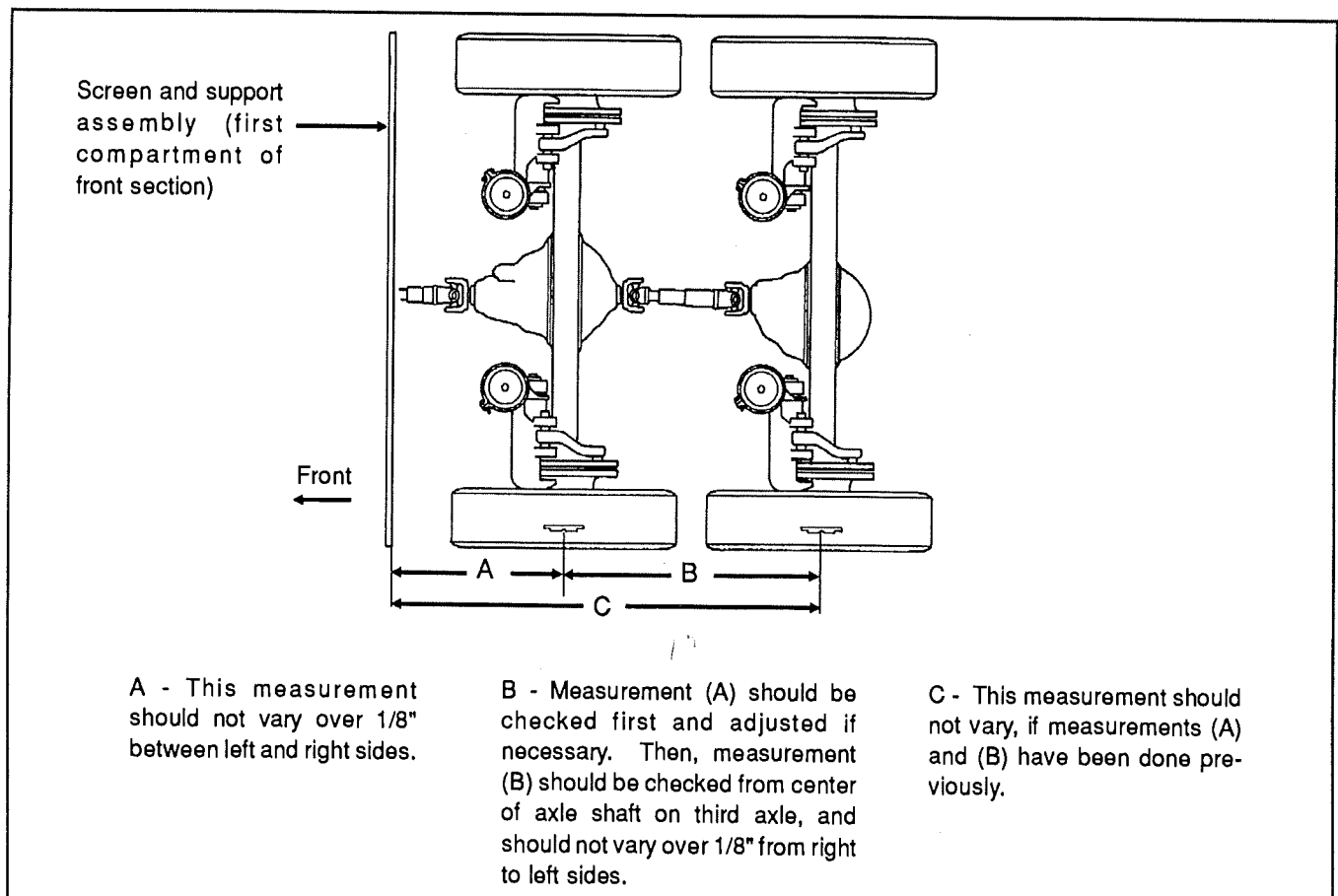

FIG. 2 - H5-60 drive axle alignment diagram

MA5-0801.IMG



## Axle to frame alignment

If drive axles are suspected to be out of alignment, perform the following procedure to inspect, adjust, and ensure that both axles are correctly aligned with frame, as well as being parallel to each other (refer to figure 2).

### Axle 3 alignment

1. Park vehicle on level floor, then using jacking points on body (refer to section 17 "Body" under heading "Vehicle jacking points"), raise vehicle sufficiently so that wheels do not touch the ground, then release parking brake.
2. Using an optical toe & tracking system installed on each side of axle 3, fix and position the projector in center of wheel. Measure the distance on each side of projector on the mounting rods; distance should be equal on both sides. If not, loosen wing nut, adjust projector to the proper distance, then tighten wing nut. Refer to figure 3.

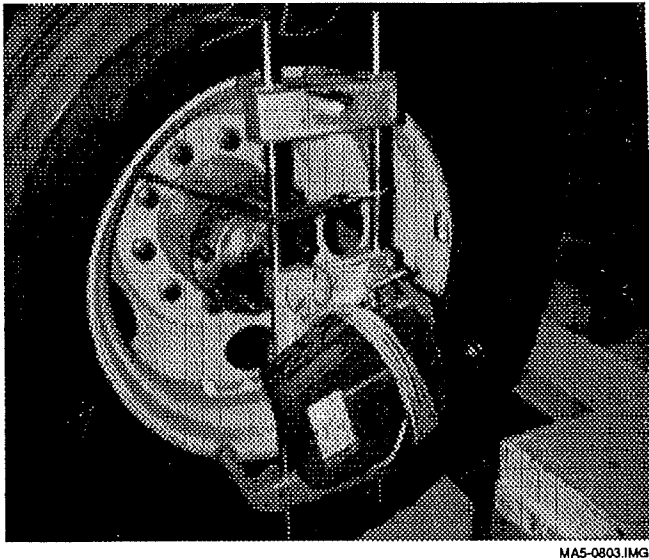

FIG. 3 - Optical toe and tracking system installation

3. Install the screen and support assembly in the first baggage compartment of front section. Assembly must be installed at an equal distance of compartment frame on both sides (about 16" (406 mm) from baggage compartment frame). Refer to figure 4 for details. Fix assembly with C-clamps.

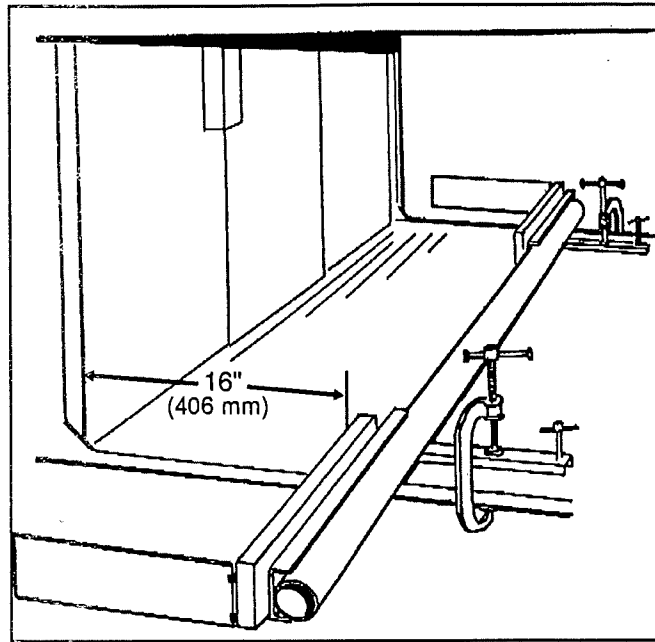

FIG. 4 - Installation of screen and support assembly in first baggage compartment of front section

4. Connect the projectors and set to zero; rotate the wheel, and set projectors to zero at four opposite positions. It is important that mark remains to zero when rotating the wheel in order to eliminate wheel run-out.
5. Lower the vehicle and remove the screen in front of mirror on each side. Aim projector at mirror, then take reading on projector. Repeat this operation on the opposite side of axle, and compare readings. If readings are identical or have a variance of 1/8" or less, adjustment is adequate. If readings is higher than 1/8", adjustment of axle is necessary.
6. Loosen suspension support retaining bolts (4) on each side of axle.
7. Loosen locknuts, then adjust (tighten or loosen) setscrew on axle so that the mark on projector will be equal on both sides; refer to figure 5 for details.

**NOTE:** Work out the average of both readings. If a difference of 1/8" or less is noted, alignment is satisfactory. If reading average is higher, the off-tracking value from axle 1 to axle 4 will be higher than the correct off-tracking. Refer to heading "Specifications" at the end of this section for off-tracking tolerance.

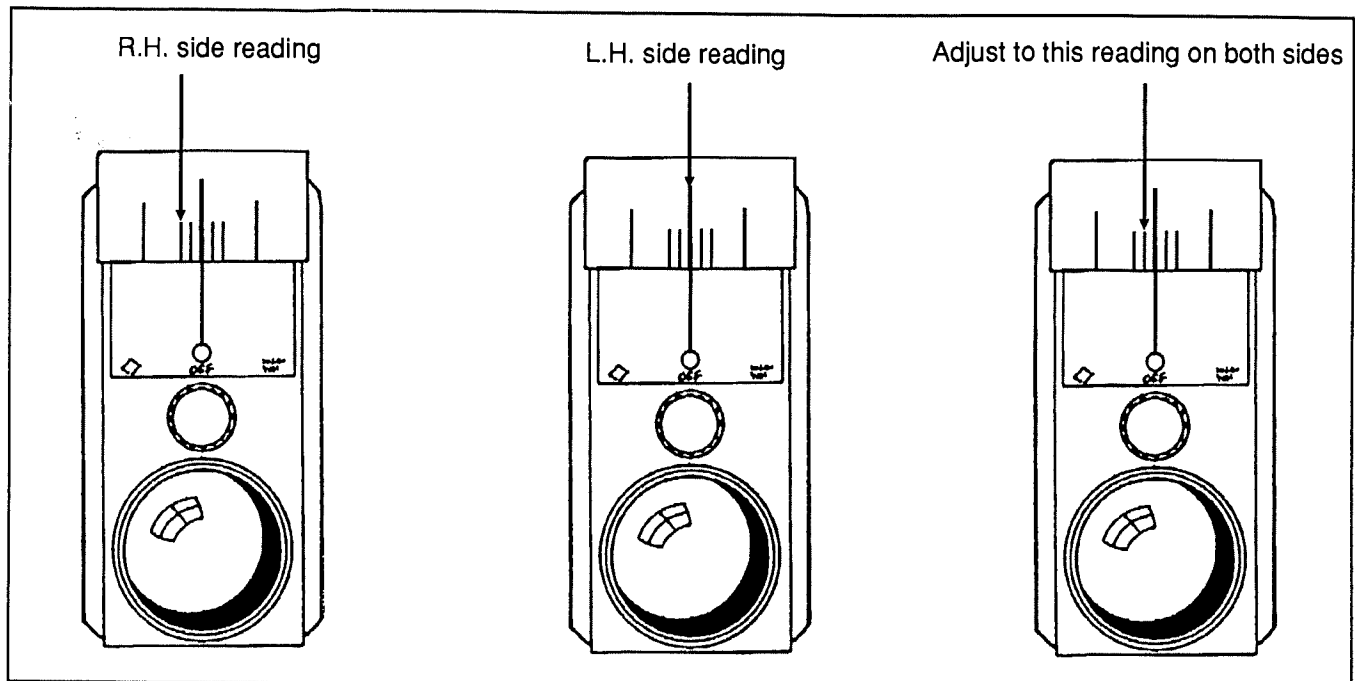

FIG. 5 - Readings on projector

MA5-0908.IMG

8. Tighten locknuts and recheck setting to make sure it is correct.
9. If correct, retighten the suspension support retaining bolts to the proper torque.

**NOTE: Refer to section 14 "Suspension" for proper tightening torques of suspension components.**

### Axle 4 alignment

If the above measurements indicate a satisfactory axle 3 to frame alignment, check alignment of axle 4 as follows:

1. Measure distance from center of axle 4 shaft to center of axle 3 shaft (forward tandem axle). See figure 6.

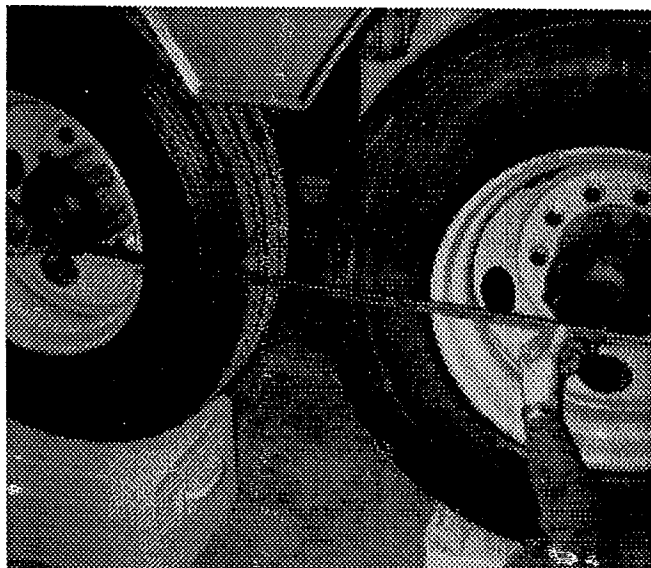

FIG. 6 - Axle #4 alignment

MA5-0806.IMG

2. Repeat operation on the opposite side and compare measurements. If a difference of 1/8" or less is noted, alignment is satisfactory. If a difference of over 1/8" is noted, axle 4 (rear tandem axle) must be aligned.
3. Loosen suspension support retaining bolts on each side.
4. Loosen the locknut on setscrew, then loosen or tighten the setscrew on axle in order to reach the proper measure. Tighten the setscrew locknut afterwards.
5. Retighten the retaining bolts on suspension support, then recheck the setting to make sure it is correct.

## SPECIFICATIONS

### REAR AXLE

Make . . . . . Rockwell International  
Series . . . . . SQ-100P  
Wheel Track . . . . . 82.95" (2 107 mm)  
Gear type . . . . . Hypoid  
Axle Type . . . . . Full floating when DLO (Differential Lock) not engaged.  
. . . . . Two positive drives with DLO engaged.  
Rear axle ratio (Std) . . . . . 3.55:1  
Rear axle lube capacity:  
- Forward axle . . . . . 40 pints (19 liters)  
- Rear axle . . . . . 37 pints (17,5 liters)



# 09

## REAR AXLE (5)

### CONTENTS OF THIS SECTION

DESCRIPTION . . . . .	9-1
REMOVAL AND REPLACEMENT . . . . .	9-1
DISASSEMBLY OF REAR AXLE . . . . .	9-2
PREPARATION FOR ASSEMBLY . . . . .	9-2
ASSEMBLY OF REAR AXLE . . . . .	9-2
REAR END ALIGNMENT (axle #5) . . . . .	9-2
REAR END INSPECTION . . . . .	9-3
REAR WHEEL CAMBER AND CASTER . . . . .	9-3
REAR WHEEL TOE-IN (axle #5) . . . . .	9-3
DIVIDER PIVOTING ARM ADJUSTMENT . . . . .	9-4
DRAG LINK PIVOT ADJUSTMENT . . . . .	9-5
REAR WHEEL ALIGNMENT IN RELATION WITH FRAME (AXLE #5) . . . . .	9-5
SPECIFICATIONS . . . . .	9-7
TORQUE SPECIFICATIONS . . . . .	9-7
REAR WHEEL ALIGNMENT SPECIFICATIONS . . . . .	9-7



## DESCRIPTION

The rear axle of this vehicle is similar to the front axles and is steered by the articulation mechanism. For maintenance and lubrication points, refer to section 09 "Front axles" under the appropriate headings. These lubrication points are also identified on the "Lubrication chart and service check points" annexed to section 19 (Lubrication).

Wheel bearings, air suspension, steering, and brake parts which are mounted on the rear axle are described in the applicable sections of this manual.

## REMOVAL AND REPLACEMENT

The following procedure deals with the removal of the rear axle assembly along with the suspension components. The method used to support the axle and the suspension components during removal and disassembly, depends upon local conditions and available equipment.

**NOTE:** It is not necessary to raise vehicle completely to remove the fifth axle, but only the rear section.

**WARNING:** When jacking only the rear section, the angle between the front and rear sections must never exceed a twelve degree (12°) angle, and the front wheels must be blocked to prevent the vehicle from rolling.

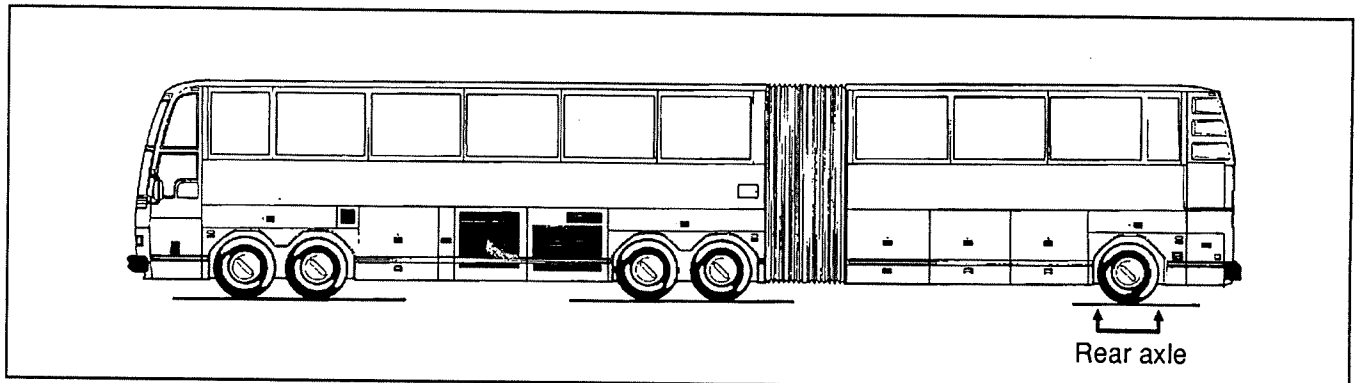

FIG. 1

BUSH560B.IMG

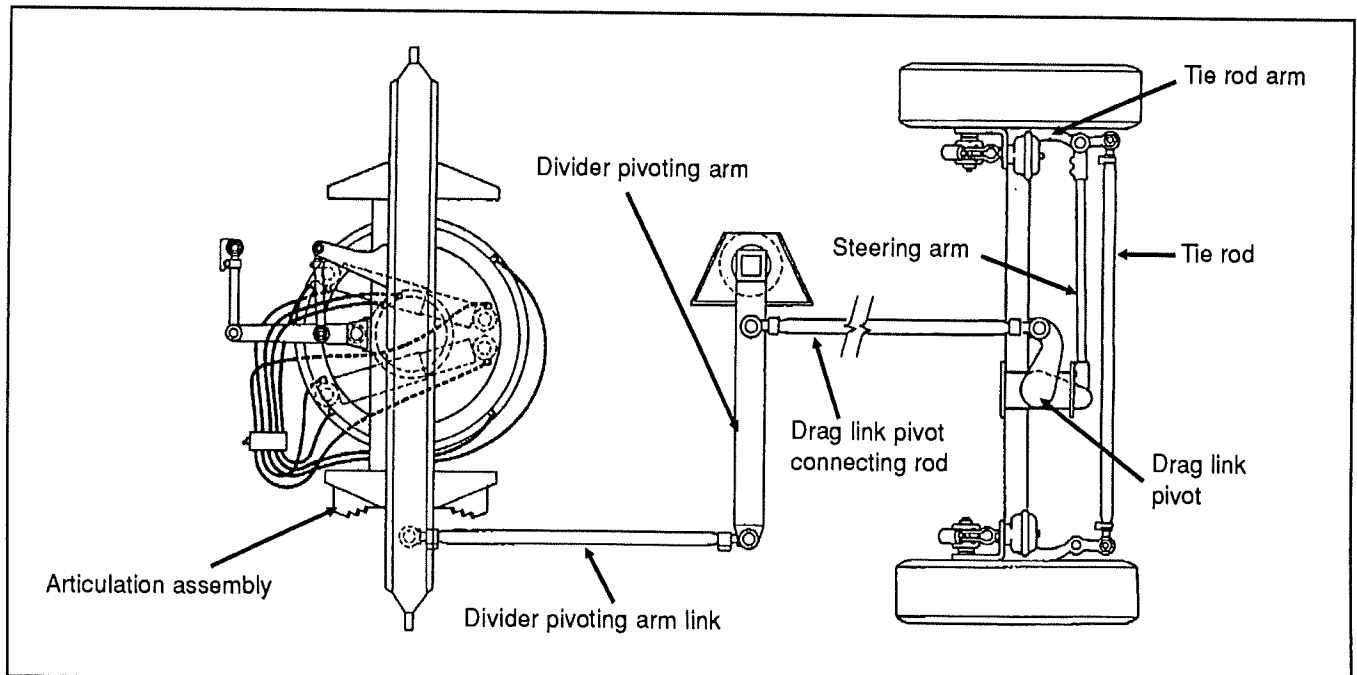

FIG. 2

MA5-0902.IMG

## Removal of axle 5

1. Raise the vehicle by its jacking points on the body (see Section 17 "Body" under heading "Vehicle jacking points"), until vehicle body is approximately 20" (508 mm) from floor. Place jack stands under frame. Remove the wheels and tires (if required, refer to section 11 under heading "Wheel and tire removal").

**CAUTION: Do not raise vehicle so the entire weight of the axle is supported by the suspension air bellows and the shock absorber pins, as damage to these components will result.**

2. Exhaust compressed air from the air supply system by opening the drain valve of each air reservoir.

3. Install jacks under axle jacking points to support the axle weight.

4. Remove the steering arm from the drag link pivot (located between the tie rod arm and the drag link pivot as shown on figure 2), then attach it to the tie rod so it will not be damaged when removing the axle.

5. Remove the cable ties retaining the ABS cables, and disconnect ABS sensor connections near the ABS solenoid control valve.

**NOTE: When removing cable ties to ease operation, remember to replace them afterwards.**

6. Disconnect the height control valve link from the overtravel lever, then pull down the height control valve lever to exhaust compressed air from the air bellows.

7. Disconnect the brake chamber hoses.

**NOTE: Position the air lines so they will not be damaged when removing the axle.**

8. Remove sway bar links from suspension supports as outlined in section 14 (Suspension) under "Sway bar removal".

9. Remove shock absorbers from suspension supports as outlined in section 14 (Suspension) under "Shock absorber removal".

10. Remove lower, upper, and transversal radius rod supports from subframe as outlined in section 14 under "Radius rod removal".

11. Unscrew the two air bellows retaining nuts on each suspension support.

12. Use the jacks to lower axle to the floor. Carefully pull away the jacks and axle assembly from under the vehicle.

## Replacement

Reverse the removal procedure to reinstall the axle.

**NOTE: Refer to section 14 "Suspension" for proper tightening torques of suspension components.**

## DISASSEMBLY OF REAR AXLE

Refer to section 07 "Front axles" under the corresponding heading for disassembly procedure.

## PREPARATION FOR ASSEMBLY

Refer to section 07 "Front axles" under the corresponding heading.

## ASSEMBLY OF REAR AXLE

Refer to section 07 "Front axles" under the corresponding heading.

## REAR END ALIGNMENT (axle #5)

### Description

Like the front wheels, the rear wheels are steerable. The only difference is that the steering of the wheels is ensured through a linkage fixed to the central joint and independent from the front steering system. When the front section turns, the central joint of the articulation will reach an angle and the rear wheels will turn by means of a divider pivoting arm and a drag link pivot. Refer to figure 2 for details.

The rear axle is identical to the front axles. Correct rear end alignment must be maintained for ease of steering and satisfactory tire life. Road shocks, vibrations, normal stresses and strains on the rear end system under average operating conditions will result in loss of rear end alignment.

If incorrect rear end alignment is suspected, rear wheel balance should first be checked to ensure that the difficulties are not originating from out-of-balance rear wheels. A check of tire inflation, wheel installation and run-out, wheel bearing adjustment, tie rod and steering arm end wear should also be made. Correct rear end alignment can only be maintained when parts in the steering knuckle are in satisfactory condition. Furthermore, pivoting arm angle as well as drag link pivot angle, should be adjusted to 90° according to the procedure given later in this section under applicable heading, and the alignment of rear section in relation with front section must be performed before proceeding with rear end alignment.



## REAR END INSPECTION

Before checking rear end alignment, inspect the following items:

1. Check that vehicle is at normal ride height.
2. Check the tires for proper inflation.
3. Check wheel installation and run-out.
4. Check wheel bearing adjustment.
5. Check tie rod and drag link ends for looseness.
6. Check knuckle pins for looseness.
7. Check alignment of section two in relation with section one.
8. Check divider pivoting arm angle.
9. Check drag link pivot angle.

## REAR WHEEL CAMBER AND CASTER

On the articulated vehicle, the rear axle is identical to the front axles. Consequently, the camber and caster are nonadjustable. However, for description and procedure to check camber and caster, refer to section 07 "Front axles" under applicable heading.

## REAR WHEEL TOE-IN (axle #5)

### Checking and correcting rear wheel toe-in

1. Check the camber adjustment and correct if required.
2. Raise the rear section of vehicle, then remove the steering arm (refer to figure 2 for steering arm location).
3. Use paint or chalk and whiten the center area of each tire around the entire circumference.
4. Position a scribe or pointed instrument against the whitened part of each tire and rotate the tires. The scribe must be held firmly in place so that a single straight line is scribed all the way around the tire.
5. Lower vehicle on floor and then move the vehicle back and forth approximately 12 to 15 feet, in order to neutralize front suspension.
6. Position wheels perpendicular to axle by placing pins on axle (see figure 3); measure the distance between pin and rim on each side. The distance should be the same on each side. If not, adjust distance by pushing inside or outside of tires as required. For example, if the distance on one side is 7 1/4" and is equal to 7" on the other side, the final reading should be 7 1/8" on each side.
7. Position trammel bar at rear of tires, adjust pointers to line up with scribe lines and lock in place (scale should be set to zero). Pointers must be raised to spindle height on the tire.

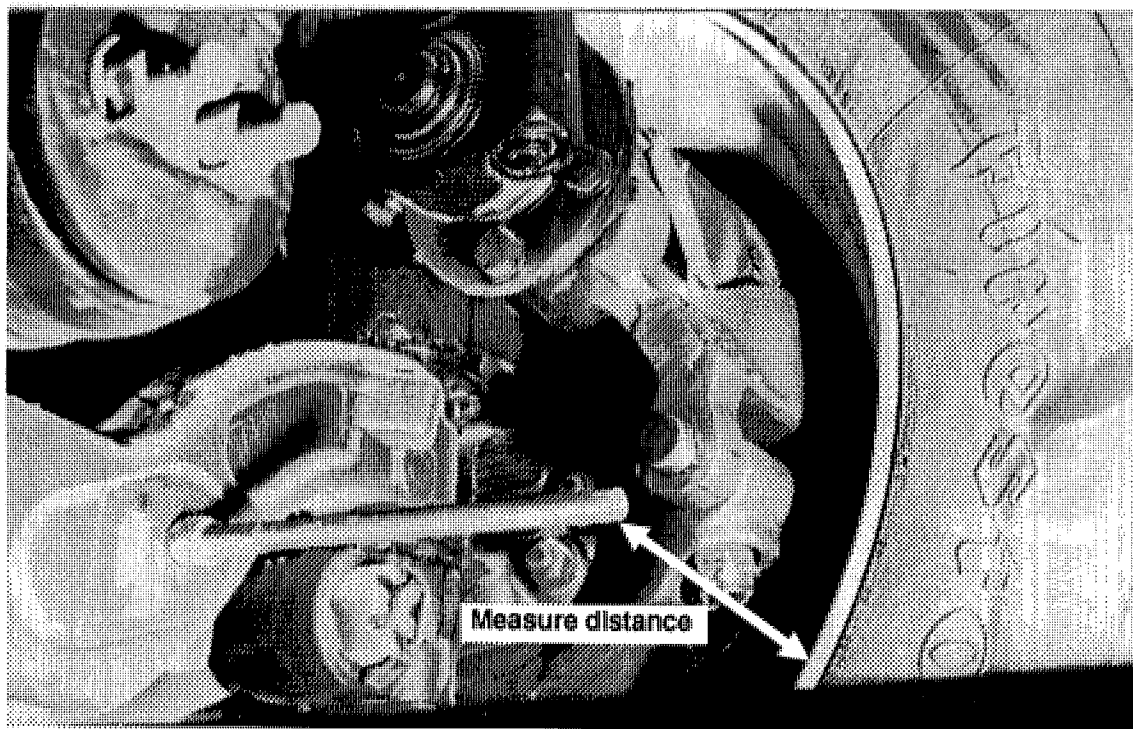

FIG. 3 - Pin Installation on axle

MA5-0903.IMG

8. Position the trammel bar at front of tires. Adjust scale end so that pointers line up with scribe marks.
9. Read toe-in (or toe-out) from scale (see figure 4).

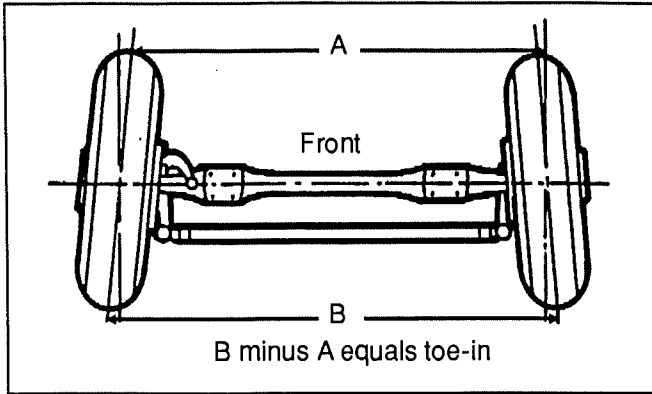

FIG. 4

10. These two measurements must be taken at the same height above the floor. Toe-in (or toe-out) is the difference between the measurements taken at the front and rear of the tires (see figure 4). The toe-in measurement should be  $3/32'' \pm 1/32''$  ( $2,38 \text{ mm} \pm 0,8 \text{ mm}$ ).

**NOTE: The same measurements can be taken with a steel tape at spindle height.**

11. If an adjustment is necessary, toe-in is adjusted by loosening the clamp bolts on the tie rod ends, and by rotating the tie rod (clockwise or counterclockwise) as required until wheels have the proper toe-in.

**NOTE: The use of a pipe wrench may be necessary when tie rod ends are jammed.**

12. With both tie rod ends in the same plane, tighten clamp bolts securely. Refer to heading "*Specifications*" at the end of section 07 "*Front axle*" for correct toe-in, and clamp bolt torque. Move vehicle backward and then forward about 12 to 15 feet. This is particularly important when setting the toe-in on vehicles equipped with radial tires.

13. Recheck toe-in setting to make sure it is correct.

## DIVIDER PIVOTING ARM ADJUSTMENT

**NOTE: Before performing this procedure, ensure the rear section is aligned with the front section. Refer to section 13 "*Articulation*" under heading "*Alignment of rear section in relation with front section*".**

Proceed as follows to adjust the divider pivoting arm angle.

### Divider pivoting arm angle adjustment.

1. Open the first baggage compartment of rear section, then remove the protective metal sheet by unscrewing each retaining screw.
2. Using a square, place one extremity against divider pivoting arm and the other extremity against the vehicle frame. Refer to figure 5 & 6 for more details. The angle of divider pivoting arm should be adjusted to  $90^\circ$ .

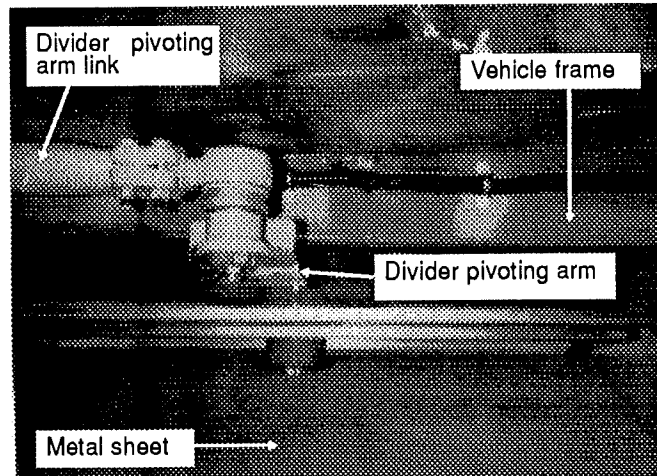

FIG. 5

3. If not, adjust angle by loosening the clamp bolts on the divider pivoting arm link ends, then by rotating it (clockwise or counterclockwise) as required, until the divider pivoting arm reaches the proper angle.
4. When proper angle is obtained, retighten the divider pivoting arm link ends to the proper torque; refer to heading "*Specifications*" at the end of this section for torque recommendations.

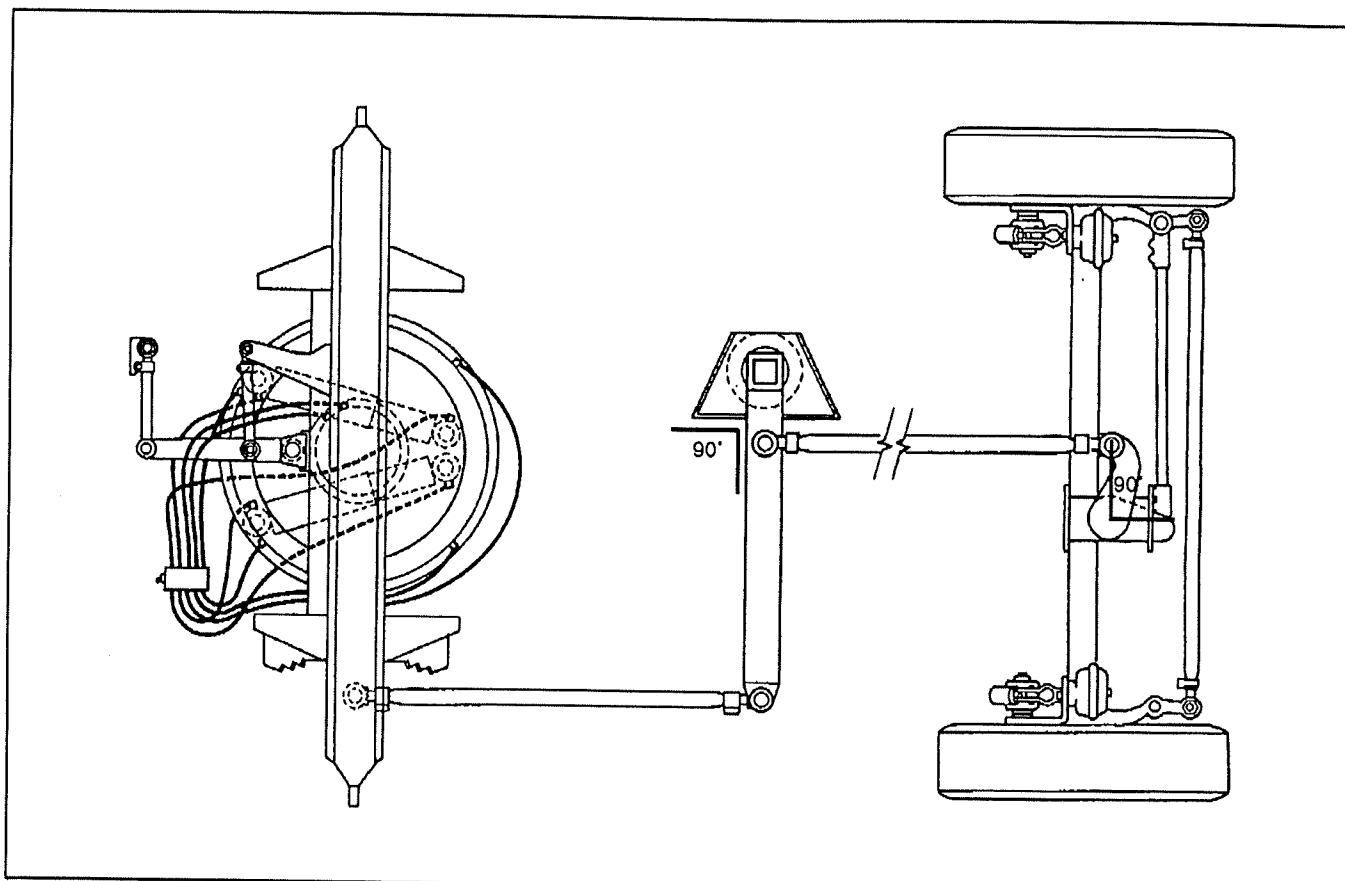

FIG. 6 - Divider pivoting arm and drag link pivot alignment

MAS-0902.IMG

## DRAG LINK PIVOT ADJUSTMENT

**NOTE:** Before performing this procedure, ensure the rear section is aligned with the front section. Refer to section 13 "Articulation" under heading "Alignment of rear section in relation with front section".

Proceed as follows to adjust the drag link pivot angle.

### Drag link pivot angle adjustment

1. At rear axle, using a square, scribe a reference mark across top center of drag link pivot connecting rod end bolt on drag link pivot extremity.
2. With one extremity of the square positioned on mark and the other on axle beam, measure the angle. The angle should be adjusted to 90° (refer to figure 6 for details).
3. If angle is incorrect, loosen drag link pivot connecting rod clamp bolts and rotate (clockwise or counterclockwise) the drag link pivot connecting rod in order to obtain the desired angle.
4. Tighten and torque drag link pivot connecting rod clamps when proper angle is reached, according to the torque recommendations given at the end of this section under heading "Specifications".

## REAR WHEEL ALIGNMENT IN RELATION WITH FRAME (AXLE #5)

### Description

The rear wheel alignment consists in aligning the wheels of axle 5 according to the frame. It is important to use the rear section frame. Proceed as follows to align rear wheels.

### Rear wheel alignment

**NOTE:** Before performing this procedure, ensure the rear section is aligned with the front section. Refer to section 13 "Articulation" under heading "Alignment of rear section in relation with front section".

1. Park vehicle on level floor, then using jacking points on body (refer to section 17 "Body" under heading "Vehicle jacking points"), raise vehicle sufficiently so that wheels do not touch the ground.
2. Using an optical toe & tracking system installed on each wheel of axle 5, fix and position the projector in center of wheel. Measure the distance on each side of projector on the mounting rods; distance should be equal

on both sides. If not, loosen wing nut, adjust projector to the proper distance, then tighten wing nut.

3. Install the screen and support assembly in the first baggage compartment of rear section. Assembly must be installed at an equal distance of compartment frame on both sides (about 16" (406 mm) in front of baggage compartment frame). Refer to figure 7 for details. Fix assembly with C-clamps.

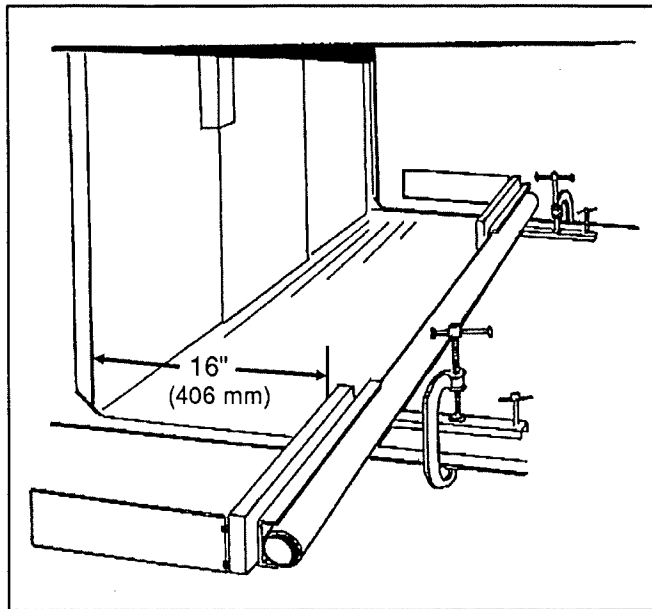

MA5-0907.IMG

FIG. 7 - Installation of screen and support assembly (inside first compartment of rear section)

4. Connect the projectors and set to zero; rotate the wheel, and set projectors to zero at four opposite positions. It is important that mark remains to zero when rotating the wheel in order to eliminate wheel run-out.

5. Lower the vehicle and remove the screen in front of mirror on each side. Aim projector at mirror, then take reading on projector. Repeat this operation on the opposite side of axle, and compare readings. If readings are identical or have a variation of 1/8" or less, alignment is correct. If variation is higher than 1/8", alignment of rear wheels is necessary.

6. Loosen steering arm end clamp bolts, then rotate (clockwise or counterclockwise) the steering arm until the proper alignment is achieved; the mark on projector should be equal on both sides. Work out the average of both readings; refer to figure 8 for details.

7. Afterwards, retighten the steering arm clamp bolts to the recommended torque given at the end of this section under heading "Specifications".

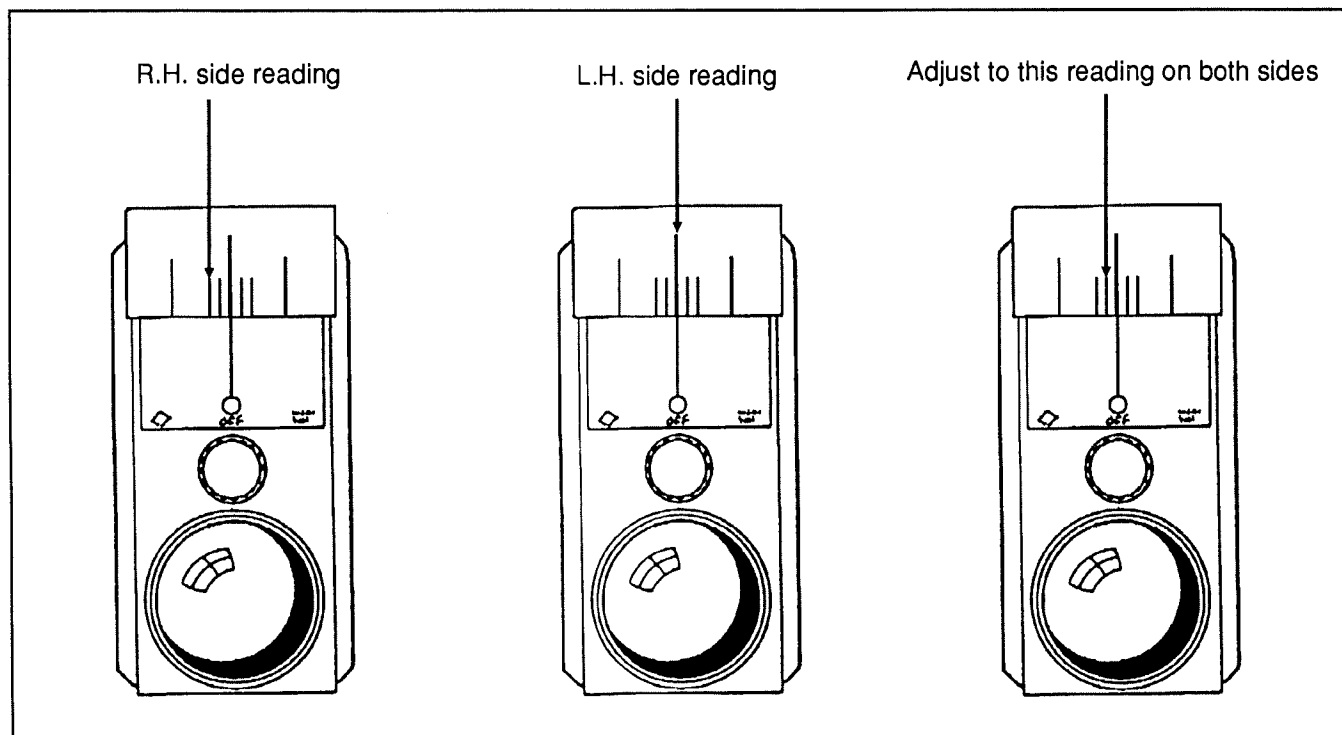

FIG. 8 - Readings on projector

MA5-0908.IMG

## REAR WHEEL ALIGNMENT SPECIFICATIONS

Camber (B minus A), degrees	Right 0° ± 3/8°
	Left 3/8° ± 3/8°
Caster	Positive 3°
Toe-in (J minus H)	3/32" ± 1/32" / 2,38 mm ± 0,8 mm
Knuckle pin inclination (U minus V), degrees	Right 6°15'
	Left 5°45'
Track	.85.67" (2176 mm)

## SPECIFICATIONS

### REAR AXLE (Same as front axles)

Make	Rockwell International
Series	FF-952 CA
Wheel Track	85.67" / 2 176 mm
Capacity (each)	13,000 lbs / 5 900 kg

## TORQUE SPECIFICATIONS

Tie rod end stud nut	160-215 ft.lbs / 218-292 N.m
Tie rod end clamp bolt nut	.50-65 ft.lbs / 68-88 N.m
Steering arm nut	160-215 ft.lbs / 218-292 N.m
Steering arm end clamp bolt nut	.50-65 ft.lbs / 68-88 N.m
Tie rod arm nut	550-740 ft.lbs / 748-1006 N.m
Drag link pivot connecting rod ends	775-1050 ft.lbs / 1054-1428 N.m
Drag link pivot connecting rod end clamp bolt nuts	.40-55 ft.lbs / 54-75 N.m
Divider pivoting arm link ends	775-1050 ft.lbs / 1054-1428 N.m
Divider pivoting arm link end clamp bolt nuts	.40-55 ft.lbs / 54-75 N.m









# 10

## BRAKES AND AIR SYSTEM

---

### CONTENTS OF THIS SECTION

AIR SYSTEM . . . . .	10-1
AIR LINES . . . . .	10-1
BRAKE OPERATION . . . . .	10-4
AIR COMPRESSOR . . . . .	10-4
GOVERNOR . . . . .	10-4
PUSH-PULL CONTROL VALVE (PP-1) . . . . .	10-4
DUAL BRAKE APPLICATION VALVE (E-10) . . . . .	10-4
BRAKE RELAY VALVES (R-12 and R-14) . . . . .	10-5
COMBINED STOP LIGHT SWITCH & DOUBLE CHECK VALVE (DS-2) . . . . .	10-5
PRESSURE PROTECTION VALVE (PR-4) . . . . .	10-5
LOW PRESSURE INDICATORS (LP-3) . . . . .	10-5
SHUTTLE TYPE DOUBLE CHECK VALVE (DC-4). . . . .	10-5
AIR GAUGES (PRIMARY AND SECONDARY) . . . . .	10-5
DOOR EMERGENCY RELEASE VALVES (FRONT AND REAR) . . . . .	10-6
FRONT BRAKE CHAMBER . . . . .	10-7
DRIVE AXLE BRAKE CHAMBER . . . . .	10-9
REAR BRAKE CHAMBER . . . . .	10-10
AIR RESERVOIRS . . . . .	10-10
DRAIN COCK . . . . .	10-11
ACCESSORY AIR FILTER . . . . .	10-12
AIR DRYER (AD-4) . . . . .	10-12
AIR PRESSURE REGULATOR . . . . .	10-12
AIR DISC BRAKES . . . . .	10-14

(SEE OVER)

## CONTENTS OF THIS SECTION (CONTD)

BRAKE PAD REPLACEMENT (SUPPLEMENT) . . . . .	10-14
BRAKE PAD CONDITIONING ("BURNISHING") . . . . .	10-14
RECOMMENDED BRAKE SERVICE PROCEDURES TO REDUCE EXPOSURE TO NON-ASBESTOS FIBER DUST . . . . .	10-15
BRAKE RELINE . . . . .	10-15
BRAKE INSPECTION AND OVERHAUL . . . . .	10-15
BRAKE INITIAL ADJUSTMENT . . . . .	10-15
BRAKE LUBRICATION AND PREVENTIVE MAINTENANCE . . . . .	10-15
TROUBLESHOOTING CHART . . . . .	10-15
BRAKE SPECIFICATIONS AND ADJUSTMENTS . . . . .	10-15
AUTOMATIC SLACK ADJUSTER . . . . .	10-15
ANTI-LOCK BRAKING SYSTEM (ABS) . . . . .	10-16
ABS COMPONENTS . . . . .	10-16
SENSOR INSTALLATION . . . . .	10-18
ABS TEST EQUIPMENT . . . . .	10-19
SPECIFICATIONS . . . . .	10-20

## AIR SYSTEM

### Description

The air system of the vehicle provides a means for braking, suspension, and for operating controls and accessories. This section deals with brake operation. Details of the suspension system are covered in section 14 of this manual. The other air operated controls and accessories are covered in their own section.

The basic air system consists of a compressor (which is mounted on and driven by the engine), air reservoirs, valves, filters, and the necessary fittings and piping.

## AIR LINES

### Air line diagram

For the complete description and location of all air system components, fittings and tubings, refer to the air line diagram annexed to this maintenance manual.

### Air lines

Copper tubing, nylon reinforced tubing, and flexible hoses are used to connect the units in the pressurized air system, including air brake system, suspension system, and accessory systems such as doors, fresh air damper cylinders, air horns etc. Furthermore, the nylon tubing is color coded to ease identification. Refer to figure 1 for the complete color identification code. Service instructions for each type of air line are also provided under the applicable subtitles.

COLOR	CIRCUIT
Red	Secondary
Green	Primary & Delivery
Yellow	Parking Brake
Blue	Suspension
Black	Accessory
White	Entrance Door

FIG. 1 - Air line color code chart

### Copper tubing

Annealed copper tubing with three-piece compression type fittings are used in the engine compartment where nonflexible hoses are required, but must be heat resistant. Connections should be checked for leakage at least every 5,000 miles (8 000 km), and tightened or replaced if necessary. When replacing copper tubing, the tubing must be free of burrs, copper cuttings, and dirt. Blow out tubing with compressed air. Any of the above-mentioned particles will destroy sealing seats in air control units. New tubing must be of the same size as the old one.

Always use new tubing ring when replacing a tubing. When tightening tube connector nuts, tighten to the specified torque to ensure an airtight connection (refer to heading "*Tightening torque for fittings*" at the end of this section). Overtightening will cause leakage. Apply SAE 10 oil or spray white grease (Prévost part No. 68-0343) to ball sleeves, tubes, and male threads, then torque to the minimum value and check for leaks. If leaking, back off tube nut about 1/2 turn and retorque to a higher than minimum value.

### Nylon tubing

Nylon tubing is used for air lines in areas where usage of this material is suitable. Nylon tubing is flexible, durable, and weather resistant. When replacing an air line, use nylon tubing only where it has been used previously. Teflon braided stainless steel hoses used in the engine compartment must be replaced only with similar hoses.

**CAUTION: Nylon air lines should be used to replace existing nylon lines only, and must comply with the color identification code to ease pneumatic system troubleshooting.**

Nylon air lines must never be routed in areas where temperature could exceed 200 °F (93 °C).

### Flexible hoses

A flexible hose is used normally where it is impractical to use copper or nylon tubing due to constant flexing during operation, such as brake chamber hoses or belt tensioner air cylinder hoses. Hose connections should be tested for leakage at least every 5,000 miles (8 000 km), and tightened or replaced if necessary. Any hose which is chafed, worn or kinked should be replaced.

## Air line serviceability test

### Operating test

If any trouble symptom such as slow brake application or slow brake release indicates a restricted or clogged air line, disconnect the suspected tube or hose at both ends and blow through it to clear the passage. Inspect tubing and hose for partial restriction that may be caused by dents or kinks. If such a condition is found, the tubing or hose should be replaced.

### Leakage test

With air system fully charged and the brakes applied, coat all tubing and hose connections with a soap solution, or use a leak detector to check for air leakage. No leakage is permissible. Leakage can sometimes be corrected by tightening the connection. If this fails to correct the leakage, new fittings, nylon tubing, copper tubing, teflon braided stainless steel and flexible hoses must be installed, as applicable.

### Maintenance

Inspect all lines for cuts, swelling, kinks or other damage or deterioration. Check for lines being pinched by other components. Retaining clips and ties must be in place. Any support or bracket should be in good condition and mounted firmly in position. Hose spring guards should be in usable condition and not distorted. Particular attention should be given to long lines. Any supporting component (clips, ties, grommets, etc.) must be secured to prevent unnecessary vibrations and eventual loosening of connections. Any leak detected should be attended to. Be sure nylon lines are not near areas of intense heat. Check for any missing grommets or loom material where chafing or cutting may occur. Replace with new material as required. In general, lines should be securely located in position and free from any binding condition which would hinder air flow.

### Air brake troubleshooting

The following tests and check lists have been designed to identify the cause(s) of a sluggish performance and/or leaks in the system. These tests require very little time to perform, and give you a general idea of the system condition. Each test is provided with a corresponding check list, that will guide you to the most common causes of problems.

Perform the following checks before carrying out the tests:

1. Examine all tubing for kinks or dents.
2. Examine all hoses for signs of wear, drying out or overheating.

**WARNING:** When working on or around brake system and its related components, the following precautions should be observed.

1. Always block vehicle wheels. Stop engine when working under a vehicle. Depleting vehicle air system pressure may cause vehicle to roll. Keep hands away from chamber push rods and slack adjusters as they may apply as system pressure drops.
2. Never connect or disconnect a hose or line containing air pressure. It may whip as air escapes. Never remove a component or pipe plug unless you are sure all system pressure has been depleted.
3. Never exceed recommended air pressure and always wear safety glasses when working with air pressure. Never look into air jets or direct them at anyone.
4. Never attempt to disassemble a component until you have read and understood the recommended procedures. Some components contain powerful springs and injury can result if not properly disassembled. Use only proper tools and observe all precautions pertaining to the use of those tools.
5. Always clean connecting piping and/or fittings, and coat pipe threads with teflon pipe sealant before installing any air brake system component.

### Pressure buildup / low pressure warning / cutoff point / governor cut-out

**CONDITION:** Vehicle parked, wheels chocked

1. Drain air reservoirs to 0 psi (0 kPa).
2. Start engine, run at fast idle; low pressure warning lights should be "ON".
3. Build up time. Start timing at 50 psi (344 kPa).
4. Low pressure warning lights should go off at or above 60 psi (413 kPa).
5. Build up time. Pressure builds from 50-90 psi (413-620 kPa) in 5 minutes.
6. Governor cutout. Cuts out at correct pressure 120-125 psi (826-861 kPa).
7. Governor cut-in. Reduce service air pressure to governor cut-in. The difference between cut-in and cut-out pressure should not exceed 25 psi (172 kPa).

For common corrections, see the following check list.

**If the low-pressure indicator cutout point is high or low:**

1. Check dash gauge with a test gauge known to be accurate.
2. Repair or replace the defective low pressure indicator switches.
3. Repair or replace buzzer or light bulb, and check wiring.

**If the governor cutout is early or late:**

1. Check dash gauge with a test gauge known to be accurate.
2. Adjust governor to desired cutout.

OR

3. Repair or replace governor as necessary after checking that compressor unloader mechanism is operating correctly.

**If pressure requires more than 5 minutes to build up from 50 to 90 psi (413-620 kPa):**

1. Check dash gauge.
2. If compressor strainer or inlet line is restricted, clean or replace element or faulty line.
3. If compressor head or discharge line is carbonized or otherwise restricted, clean or replace.
4. If discharge valves are leaking, pull head and correct or replace cylinder head.
5. If drive is slipping, change gear as indicated.
6. If inlet valves are stuck, open or leaking severely, replace unloader kit, inlet valves and/or seats as necessary.
7. If drain cock is found open, close it.
8. If governor leaks when "unloaded", clean or replace inlet valve, or replace governor.
9. Listen for air leaks and repair.

**Retest to check out all items repaired or replaced.**

**Leakage reservoir air supply**

**CONDITION:** Full pressure, engine stopped, parking brake applied

1. Allow pressure to stabilize, at least 1 minute.
2. Observe pressure gauge, time for 2 minutes and note any pressure drop.
3. Pressure drop should not be more than 3 psi (20 kPa) in 1 minute.

For common corrections, see the following check list.

**If there is excessive leakage on reservoirs:**

1. If discharge valves and/or discharge line check valve is leaking, repair or replace cylinder head and/or check valve as necessary.
2. If stop light switch is leaking, repair or replace as necessary.
3. If foot brake is leaking, repair or replace inlet valve or exchange unit.
4. If supply or inlet valve, or relay or relay emergency valve is leaking, replace the defective parts or replace valve.

5. If safety valve is leaking, clean or replace parts or replace valve.

6. If governor leaks when "unloaded", clean or replace parts or replace valve.

7. Listen for leaks in "pressure" or "reservoir" side of system, and correct as required.

**Retest to check out all items repaired or replaced**

**Leakage service air delivery**

**CONDITION:** Full pressure, engine stopped, parking brake released

1. Apply foot brake, allow pressure to stabilize for at least 1 minute.
2. Hold foot valve application, observe gauge and time for 2 minutes.
3. Pressure drop should not be more than 4 psi (27 kPa) in 1 minute.

For common corrections, see the following check list.

**If there is excessive leakage on the service side, do this:**

1. If foot exhaust valve is leaking, repair or replace valve or replace unit. If one or the other valves leaks in released position when other valve is applied, check for leaking double check valve, and repair or replace device.
2. If stop light switch is leaking, repair or exchange as necessary.
3. If exhaust valve, relay piston, or diaphragm in relay is leaking, clean or replace parts or replace as necessary.
4. If quick release valve is leaking, clean or replace parts or replace as necessary.
5. If brake chamber diaphragm is leaking, replace it.
6. Listen for any other leakage in "application" side of system and correct as necessary.

**Retest to check out all items repaired or replaced**

## BRAKE OPERATION

### Description

The vehicle braking system uses both service and parking air-operated brakes. The air system is divided in three (3) independent circuits to isolate the front axle brakes, the drive axle brakes and the rear axle brakes, thus providing safe braking operation in the event that one circuit of the system fails. The primary circuit is connected to the drive axle brakes (3 & 4), the secondary circuit to the front axle brakes (1 & 2), and the third circuit to the rear axle brakes (5). The spring type emergency brakes are located on the two drive axles, and will apply automatically in case of primary system failure. The optional parking brake override system can cancel the parking brakes, in order that the driver moves the vehicle to a safe parking place. To operate this system, push down and hold the control knob located on the R.H. lateral console (see "Operator's Manual").

Furthermore, the brake application sequence, which is sped up by a pneumatic relay valve (R-12), will start with the rear section axle, the drive axles, and finally the front axles, thus providing uniform braking on a very slippery road. The vehicle is also equipped with an Anti-lock Braking System (ABS), which is detailed later in this section.

## AIR COMPRESSOR

Maintenance and repair information on TU-FLO 700 air compressor is supplied in the applicable booklet, annexed to this section under reference number SD-01-5.

## GOVERNOR

Maintenance and repair information on D-2 governor is supplied in the applicable booklet, annexed to this section under reference number SD-01-16.

## PUSH-PULL CONTROL VALVE (PP-1)

Maintenance and repair information on the push-pull control valve is supplied in the applicable booklet, annexed to this section under reference number SD-03-61.

## DUAL BRAKE APPLICATION VALVE (E-10)

### Brake pedal adjustment

After brake pedal replacement or repair, install the pedal to its proper position according to the following procedure:

**Situation 1:** The dual brake application valve (E-10) has been changed.

1. Without the linkage between brake pedal and service brake valve (E-10), adjust according to the figure 2, the brake pedal maximum travel. When maximum travel ends, pedal resistance will increase abruptly.
2. If maximum travel is incorrect, unscrew the locknut at the bottom of valve pivot (refer to figure 2) and loosen or tighten the adjusting screw to obtain a maximum travel of 9/16" (15 mm), then tighten the locknut.

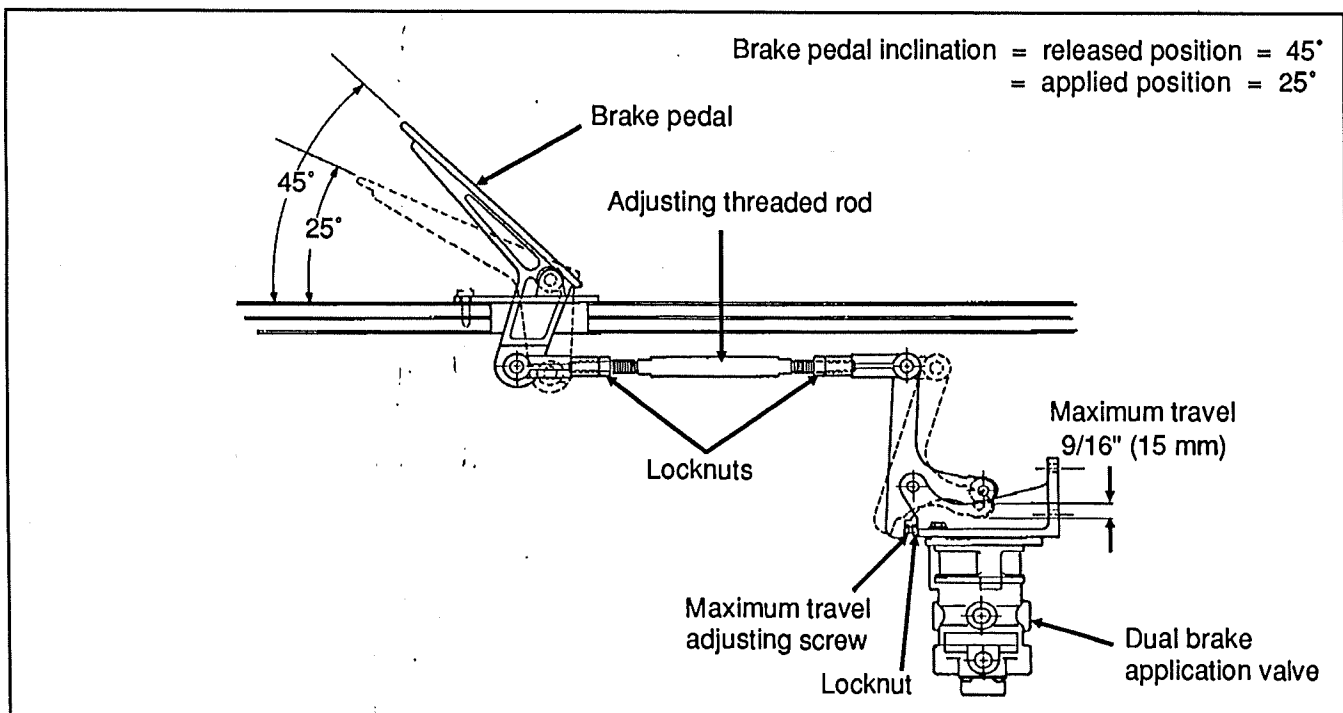

FIG. 2 - Brake pedal adjustment

MA5-1002.IMG

3. Replace the linkage, loosen threaded rod locknuts, and screw or unscrew the adjusting threaded rod in order to obtain a brake pedal inclination corresponding to 45° (refer to figure 2). Tighten threaded rod locknuts.

**Situation 2:** Only brake pedal has been changed

1. When only the brake pedal has been removed, proceed with step 3, i.e the adjustment of brake pedal inclination (45° angle).

## Dual brake application valve maintenance

Maintenance and repair information on the E-10 dual brake application valve is supplied in the applicable booklet, annexed to this section under reference number SD-03-5.

## BRAKE RELAY VALVES (R-12 and R-14)

Maintenance and repair information on the brake relay valves is supplied in the applicable booklet, annexed to this section under reference number SD-03-31.

## COMBINED STOP LIGHT SWITCH & DOUBLE CHECK VALVE (DS-2)

Maintenance and repair information on the combined stop light switch & double check valve is supplied in the applicable booklet, annexed to this section under reference number SD-06-7. This valve is located inside the front service compartment, mounted to the dual brake application valve (see figure 3 for details).

## PRESSURE PROTECTION VALVE (PR-4)

Maintenance and repair information on the pressure protection valve is supplied in the applicable booklet, annexed to this section under reference number SD-03-55. This valve is mounted on a board, which is located on the R.H. side inside the front service compartment (see figure 3 for location, and 4 for details).

## LOW PRESSURE INDICATORS (LP-3)

Maintenance and repair information on the low pressure indicators is supplied in the applicable booklet, annexed to this section under reference number SD-06-2. This valve is mounted on a board, which is located on the R.H. side inside the front service compartment (see figure 3 for location, and 4 for details).

## SHUTTLE TYPE DOUBLE CHECK VALVE (DC-4).

Maintenance and repair information on the shuttle type double check valve is supplied in the applicable booklet, annexed to this section under reference number SD-03-67. This valve is mounted on a board, which is located on the R.H. side inside the front service compartment (see figure 3 for location, and 4 for details).

## AIR GAUGES (PRIMARY AND SECONDARY)

The air pressure gauges, located on the central dashboard panel (see "Operator's Manual"), are connected to the DC-4 double check valve, which is located on the R.H. side of the front service compartment. The latter is connected to the air lines running from the primary and secondary air tanks, as shown on the pneumatic system diagram annexed to this manual.

The vehicle should never be set in motion until the buzzer alarm and warning lights turn off, i.e when air pressure registers 65 psi (448 kPa) or less. Moreover, if pressure drops below 65 psi (448 kPa), the "Low air pressure" warning lights will turn "ON", and the "Low air pressure" buzzers will sound. Stop the vehicle immediately, determine and correct the cause(s) of pressure loss. Check the gauges regularly with an accurate test gauge. Replace the gauge with a new unit if there is a variation of 4 psi (28 kPa) and over in reading.

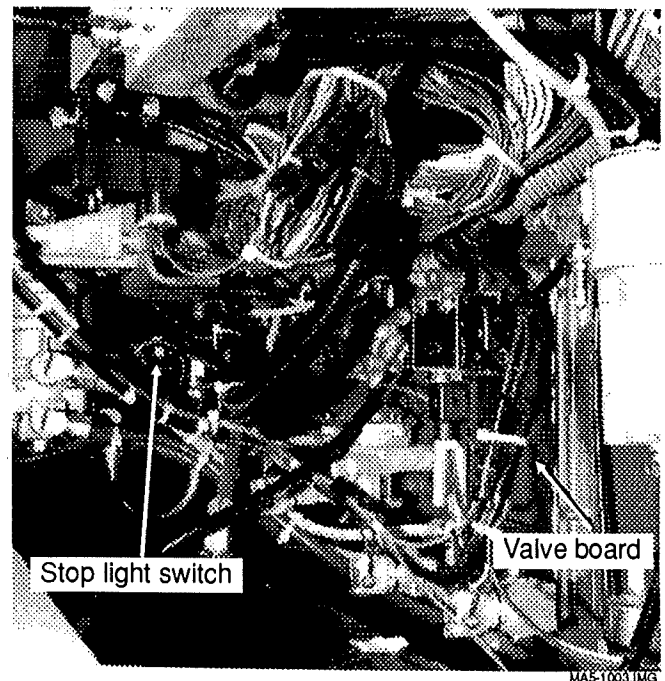

FIG. 3 - Front service compartment

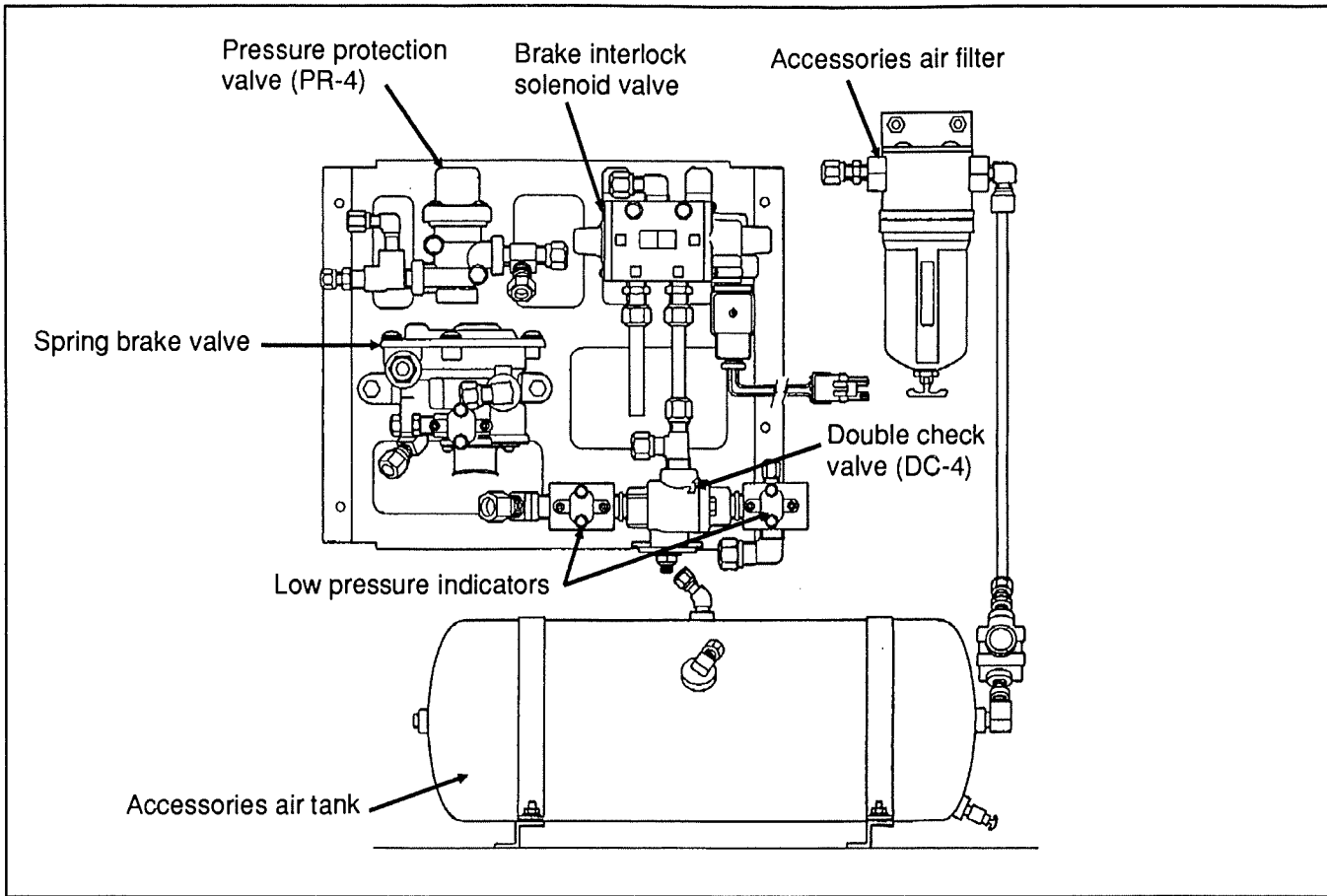

FIG. 4 - Valve identification on board

MA5-1004.IMG

## DOOR EMERGENCY RELEASE VALVES (FRONT AND REAR)

Each door of the vehicle is provided with an emergency release valve, in the event of possible malfunction of its main control or failure of its internal components. The emergency release valve cuts off the air supply to the front or the rear door spindle drive motor, and simultaneously exhaust the delivery line air and the spindle drive motor remaining air, thus allowing door to be manually operated during an emergency. The rear door emergency release valve control is located inside the safety equipment box, on the R.H. wall of rear stepwell (see figure 5). To open it, unscrew both 1/4 turn latches and remove access panel. The front door control is located on the R.H. lateral console, beside parking brake control knob (see figure 6).

The door emergency release valves should be checked periodically for leakage by applying a soap solution to the exhaust ports while the valve is closed. Internal leakage will be evident by the appearance of bubbles. If leakage is noted, or either valve fails to operate properly, remove and repair, or replace the malfunctioning valve.

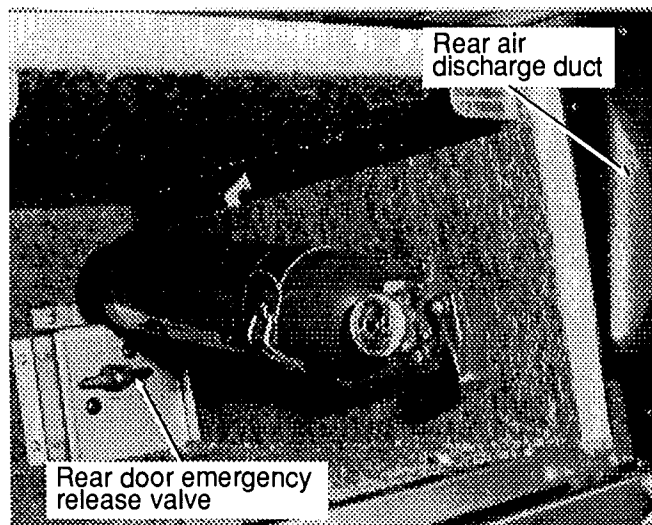

FIG. 5 - Rear safety equipment box

MA5-1005.IMG



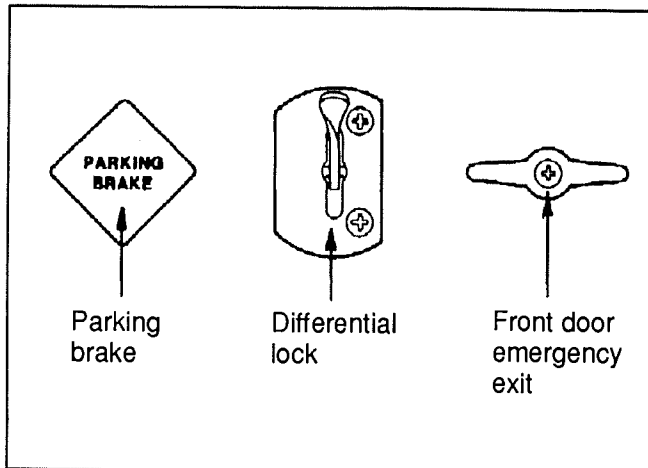

FIG. 6 - R.H. lateral console (standard)

## Removal and installation

### Rear door emergency release valve

1. Open rear safety equipment box by unscrewing the two (2) 1/4 turn latches and remove the access panel.
2. Remove the extinguisher, and locate the valve at bottom of the box.
3. Remove the four (4) retaining screws of the valve support, then remove the valve from its support by unscrewing the two (2) retaining nuts on support.
4. Remove the screw securing the T-handle to the valve.
5. Disconnect the supply and delivery air lines of valve.
6. Remove and repair, or replace as necessary.

### Front door emergency release valve

1. Remove the four (4) retaining screws on the R.H. lateral console cover and the one retaining the valve T-handle.
2. Pull and turn over the cover, then unscrew the two (2) nuts retaining the emergency release valve.
3. Disconnect the supply and delivery air lines of valve.
4. Remove and repair, or replace as necessary.

## FRONT BRAKE CHAMBER

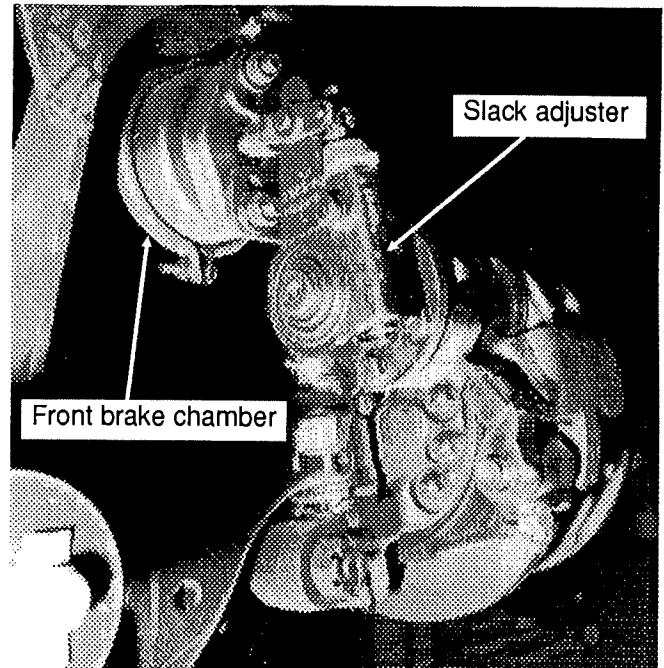

FIG. 7 - Front brake chamber and slack adjuster installation

## Preventive maintenance

### Every 8000 miles (13 000 km) or 300 operating hours, depending on type of operation.

1. Check push rod travel and adjust travel at the slack adjuster if required. Push rod travel should be as short as possible without brakes dragging. Excessive push rod travel reduces braking efficiency, shortens diaphragm life, gives slow braking response and wastes air.
2. Check push rod to slack adjuster alignment from release to full stroke position, to ensure push rod moves out and returns properly without binding, to the non-pressure plate hole or with other structures.
3. Check tightness of mounting nuts. Ensure that cotter pins are in place.
4. Check all hoses and lines. They should be secure and in good condition.

### Every 100,000 miles (160 000 km) or 3600 operating hours, depending on type of operation.

1. Disassemble and clean all parts.
2. Install new diaphragm or any other part if worn or deteriorated. When the diaphragm, spring, or both are replaced, they should be replaced in the corresponding chamber on the same axle.

## Operating and leakage tests

### Operating test

1. Apply brakes and observe the push rods move out promptly without binding.
2. Release brakes, and observe that the push rods return promptly and without binding, to the released position.
3. Check push rod travel. Push rod travel should be as short as possible without brakes dragging. Adjust travel of push rod at slack adjuster if necessary.

### Leakage test

1. Make and hold a full brake application.
2. Coat clamping ring(s) with a soap solution. If leakage is detected, tighten clamping ring only enough to stop leakage. **Do not overtighten** as this can distort sealing surface or clamping ring. Coat area around push rod hole (loosen boot if necessary). No leakage is permitted. If leakage is detected, the diaphragm must be replaced.

## Removing and installing

### Removing

1. Block vehicle wheels.
2. Release air pressure in all reservoirs.
3. Disconnect the chamber air hose.
4. Remove the yoke pin.
5. Remove the brake chamber.

### Installing

1. Mount brake chamber to mounting bracket.
2. Install yoke (if removed) and yoke pin.
3. Check the angle formed by the centerline of the push rod and slack adjuster. This angle should be greater than 90° in released position and near 90° after adjustment of stroke.
4. Connect air hose to chamber. Check that hoses are properly supported and clamped as necessary to provide proper clearance.

## Disassembly

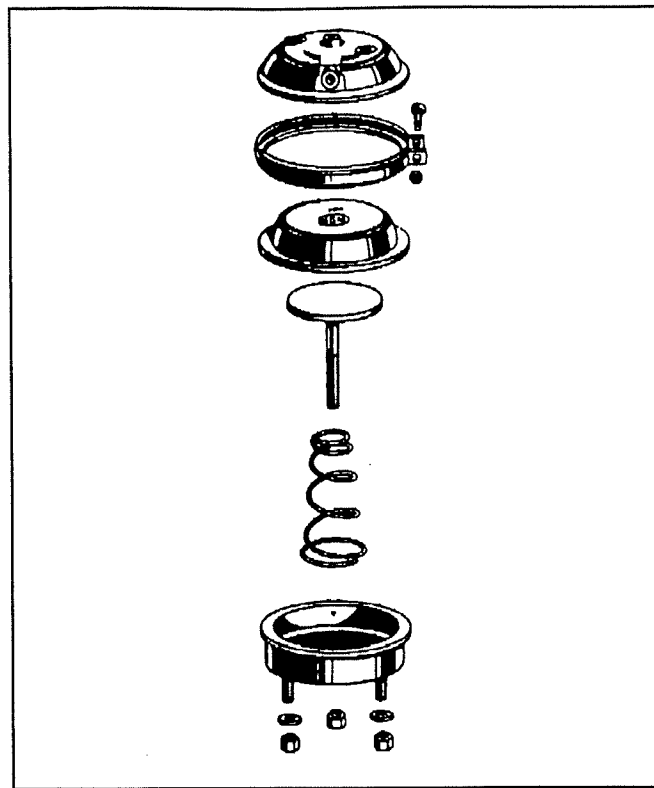

FIG. 8 - Disassembly of front brake chamber

**WARNING:** Refer to the previous "WARNING" before proceeding with each of the following steps.

Clean exterior of brake chamber and mark position of parts with respect to each other, so that it may be reassembled in the same way.

**NOTE:** If the brake chamber is to be dismantled without removing the non-pressure plate from vehicle, slack adjuster should be backed-off.

### Clamping type chamber:

1. Pull out (or push out with air pressure) push rod and clamp it to the non-pressure plate. If using "vise-grip" pliers, push rod should be protected so that it will not be damaged.
2. Remove clamp ring nut and bolt (refer to figure 8 for details).
3. Spread the ring slightly, just enough to slip it off the plate. Care should be used so that clamp ring is not distorted.
4. Remove pressure plate and diaphragm.
5. Remove yoke lock nut and yoke from push rod, and release pressure on push rod, being careful to hold the push plate and the non-pressure plate until the return spring load is released.
6. Remove push rod assembly and spring.
7. Remove boot or O-ring (if applicable).

## Cleaning and inspection

1. Clean all metal parts in cleaning solvent, taking care to remove all rust and scale. All diaphragm sealing surfaces should be smooth and clean.
2. Inspect carefully all metal parts for cracks, distortion or damage.
3. Replace all rubber parts and any other part not considered serviceable.

## Assembly

1. Place push rod assembly upright on a flat surface.
2. Position return spring on push rod.
3. Install boot or O-ring (if applicable) on non-pressure plate.
4. Position non-pressure plate on push rod, and press plate down against spring tension until plate bottoms on flat surface. Clamp rod with "vise grip" pliers (while protecting rod) to the plate.
5. Position ring over clamping surface of non-pressure plate.
6. Check alignment marks (made before disassembly), position diaphragm in pressure plate and place assembly on non-pressure plate.
7. Work the clamp ring over the clamping surface of the pressure plate and draw the clamp lugs together with "vise grip" pliers or a similar tool. Install bolt and nut in clamp and tighten, tapping with a soft faced mallet to center the clamp ring if necessary. Release pressure on push rod and install remaining bolt and nut.
8. Tighten nut and bolt evenly and sufficiently to eliminate leakage.

## Testing of a rebuilt brake chamber

Perform tests outlined under "Operating and Leakage Tests" heading.

## DRIVE AXLE BRAKE CHAMBER

### Description

The drive axle brake chamber combines the functions of a conventional service brake chamber, along with a secondary diaphragm and locking mechanism to give emergency and parking operation (see figure 9 for details).

**WARNING:** Spring brake chambers contain an extreme high pressure spring, which can possibly cause serious injuries if special precautions are not taken when working around this area. To avoid such injuries, the following recommendations must be applied:

- 1) Prévost recommends the installation of a new spring brake chamber if it is found defective.
- 2) Spring brake chamber maintenance and/or repairs must be performed by a trained and qualified personnel only.
- 3) Before manually releasing spring brakes, visually check spring brake chambers for cracks and/or corrosion.
- 4) Check that the cross pin of the release tool is securely inserted and seated in pressure plate receptacle before turning the nut to cage the spring.
- 5) Never stand in the axis line of the spring brake chambers, especially when compressing the spring.

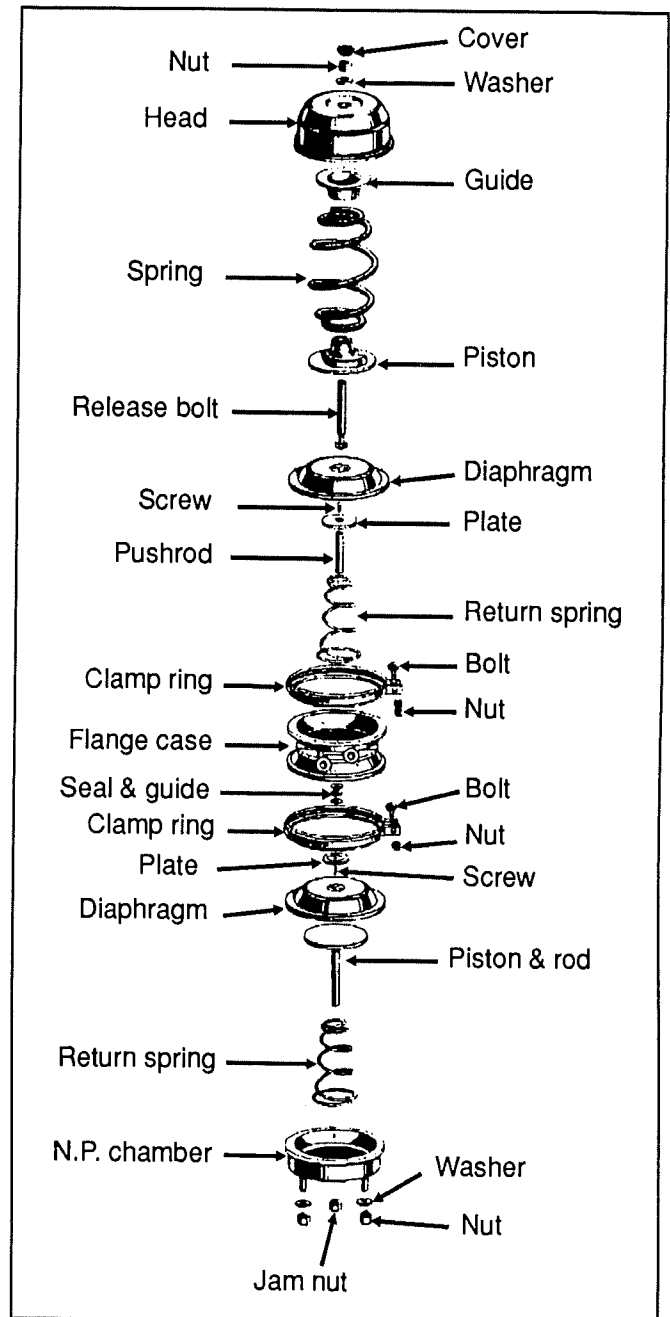

FIG. 9 - Disassembly of spring brake chambers

MA5-1009.IMG

## Maintenance

Every 5,000 miles (8 000 km) depending on type of operation:

- 1) Check push rod travel and adjust travel at the slack adjuster as necessary. Push rod travel should be as short as possible without brake dragging.
- 2) Check push rod to slack adjuster alignment from release to full stroke position, to ensure that push rod moves out and returns properly without binding. Also check the angle formed by the slack adjuster arm and the push rod. It should be 90° or greater when the chamber is in the applied or released position.
- 3) Check tightness of mounting nuts. Check that cotter pins are in place.
- 4) Check all hoses and lines. They should be secure and in good condition.

Every year or after 100,000 miles (160 000 km), depending on type of operation:

- 1) Disassemble and clean all parts.
- 2) Install new diaphragm or any other part if worn or deteriorated.

**NOTE: When the diaphragm, spring, or both are replaced, they should be replaced with the corresponding chamber on the same axle.**

## Leakage test

- 1) Make and hold a full brake application.
- 2) Coat clamping ring(s) with a soap solution. If leakage is detected, tighten clamping ring(s) only enough to stop leakage. **Do not overtighten** as this can distort clamping ring. Coat area around push rod hole. No leakage is permitted. If leakage is detected, the diaphragm must be replaced.

## Removal and installation

### Removal

- 1) Block and hold vehicle wheels by means other than the parking brake.
- 2) Apply parking brake.
- 3) Release spring brakes mechanically.
- 4) Disconnect air lines from chamber.
- 5) Remove the yoke pin.
- 6) Unscrew brake chamber retaining bolts, then remove the brake chamber.

## Installation

- 1) Mount brake chamber to mounting bracket and tighten retaining bolts.
- 2) Install yoke pin.
- 3) Check the angle formed by the push rod and the slack adjuster arm. It should be greater than 90° in both applied and release positions.
- 4) Connect air lines to chamber. Check that hoses are properly supported in order to provide proper clearance.

## Diaphragm replacement

- 1) Clean exterior of brake chamber and mark port position with respect to each other so that it may be assembled in the same manner.
- 2) Release spring brakes mechanically.
- 3) Remove spring brake clamps and/or service brake clamps depending on which diaphragm has to be replaced.
- 4) Remove chamber assembly and diaphragm.
- 5) Discard old diaphragm from chamber and replace with new diaphragm.
- 6) To reassemble the unit, reverse the procedure. Tap clamps to insure proper seating.

## REAR BRAKE CHAMBER

Since the rear brake chambers on axle 5 are identical to those on axle 1, refer to previous heading "*Front Brake Chambers*" in this section for maintenance and service.

## AIR RESERVOIRS

### Location & function

Refer to figure 10 for location of the six (6) air reservoirs. Each reservoir has a specific function: one for the primary brake system, one serves as the wet tank, one for the secondary brake system (secondary), one serves as the service tank for the rear axle brakes (5), and the remaining two are respectively for the pneumatic accessories and the kneeling system.

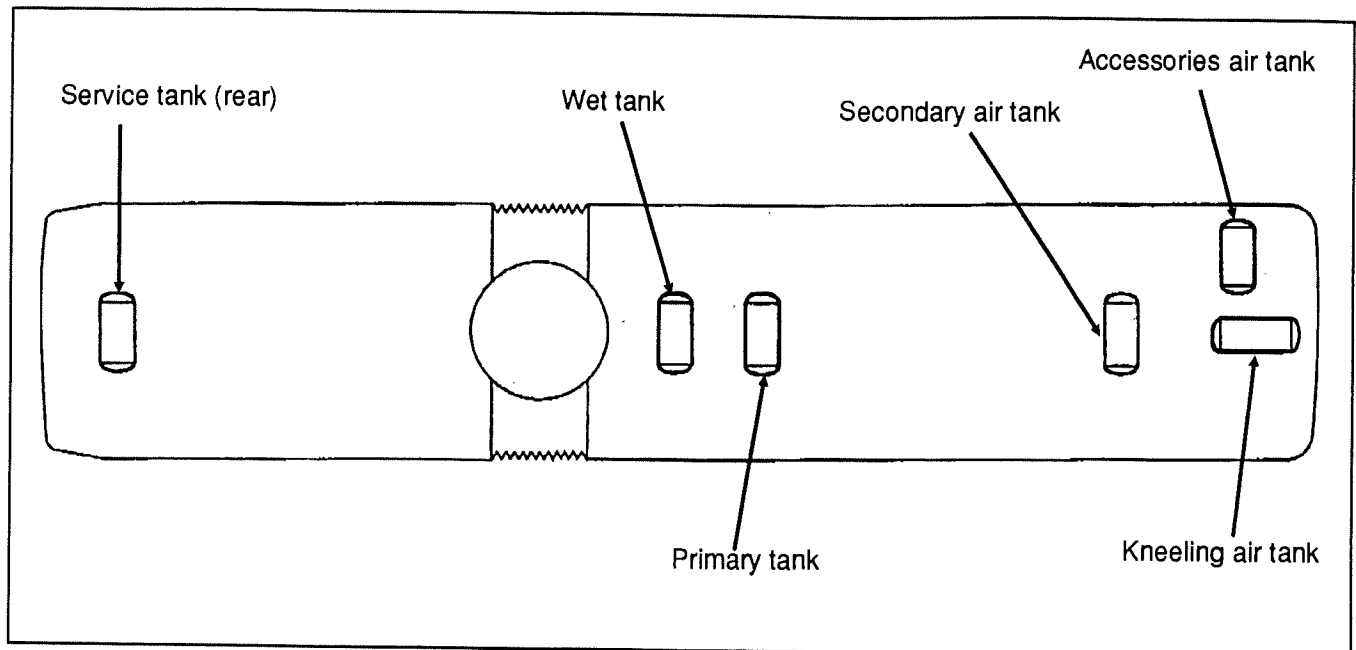

FIG. 10 - Location and function of air reservoirs

MA5-1010.IMG

## Maintenance

The reservoirs on this vehicle need not be drained daily, as an air dryer (AD-4) eliminates most of the humidity in the system. However, the reservoirs should be manually drained periodically to verify the proper functioning of the air dryer and remove the remaining humidity in the system. A filter, which is provided with a sight glass indicator and located in the front service compartment, shows at a glance the system's condition, thus enabling to make the necessary corrective measures.

Reservoirs, which have collected a considerable oily emulsion, should be drained completely by slowly opening the drain cock at the bottom of each tank. Leave the drain cock open until all air is exhausted from the reservoir and until drainage has stopped.

Moreover, reservoirs mounting bolts should be checked for tightness at regular intervals and tightened as required. The inside and outside surfaces of the reservoirs may be cleaned with steam or hot water. Inspect for corrosion or other damage. Replace any reservoir that is not in good condition.

**WARNING:** Always wear an adequate safety equipment to perform this operation as hot water or steam can cause severe burns.

## DRAIN COCK

A drain cock is installed at the bottom of each air reservoir (see figure 11). The unit should be checked periodically for leakage with a soap solution. No leakage is permitted. Ensure that the spring is in good condition and has enough force to hold the valve shut. In case of leakage or other damage, replace the drain cock assembly.



FIG. 11 - Drain cock

MA5-1011.IMG

## ACCESSORY AIR FILTER

### Description

This filter is located inside the front service compartment, and its main function consists in straining the air supply of the accessory air reservoir, when it is connected to an external air supply line. The filter is also provided with a sight glass indicator, thus giving the condition of the pneumatic system at a glance. Refer to figure 12 for more details.

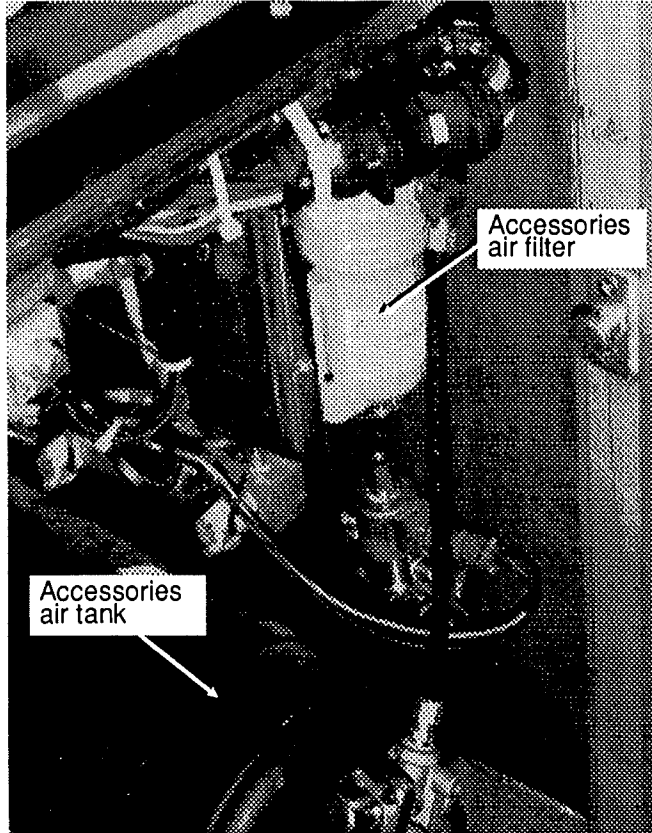

FIG. 12 - Front service compartment

### Maintenance

Maintenance of this filter is limited to the replacement of the cartridge element, whenever differential pressure exceeds 15 psi (100 kPa) between the inlet and the outlet.

### Cleaning

1. Clean bowl using warm water only. Clean other parts using warm water and soap.
2. Dry parts and blow out internal passages in body using clean dry compressed air. Blow air through filter element from the inside towards the outside to dislodge surface contaminants. Replace filter element when plugged.
3. Inspect all parts carefully and replace damaged parts.

## AIR DRYER (AD-4)

Maintenance and repair information on the air dryer is supplied in the applicable booklet, annexed at the end of this section under reference number SD-08-4. Air dryer is located on the wall rearwards drive tandem axles (see figure 13).

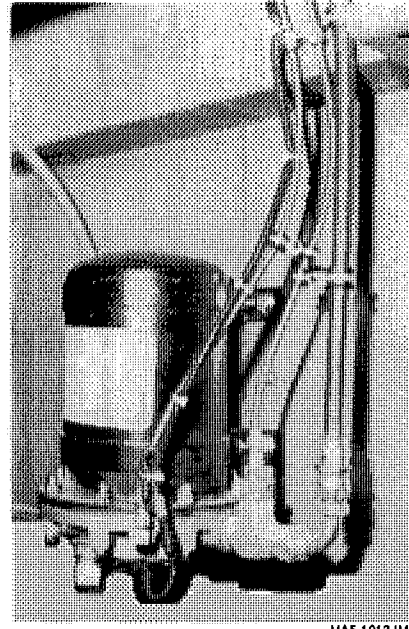

FIG. 13 - Air dryer installation (AD-4)

## AIR PRESSURE REGULATOR

### Adjustment

The pressure setting is determined by the tension of the spring, which in turn is controlled by an adjusting screw at the top of the valve. Turning the adjusting screw clockwise raises the pressure setting, while counterclockwise reduces the setting (see figure 14). The locknut must be tightened after final adjustment is accomplished.

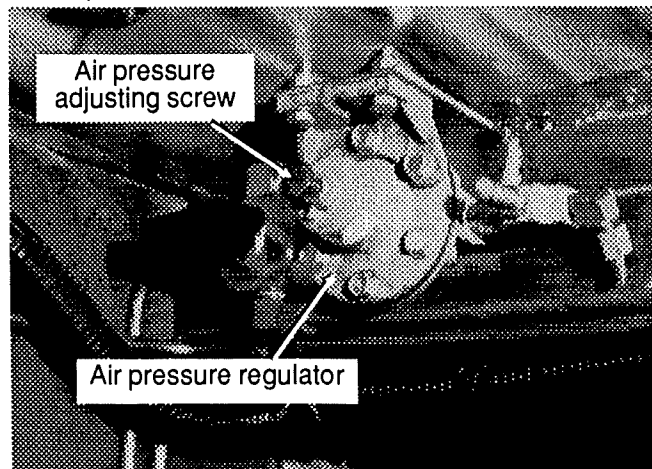

FIG. 14

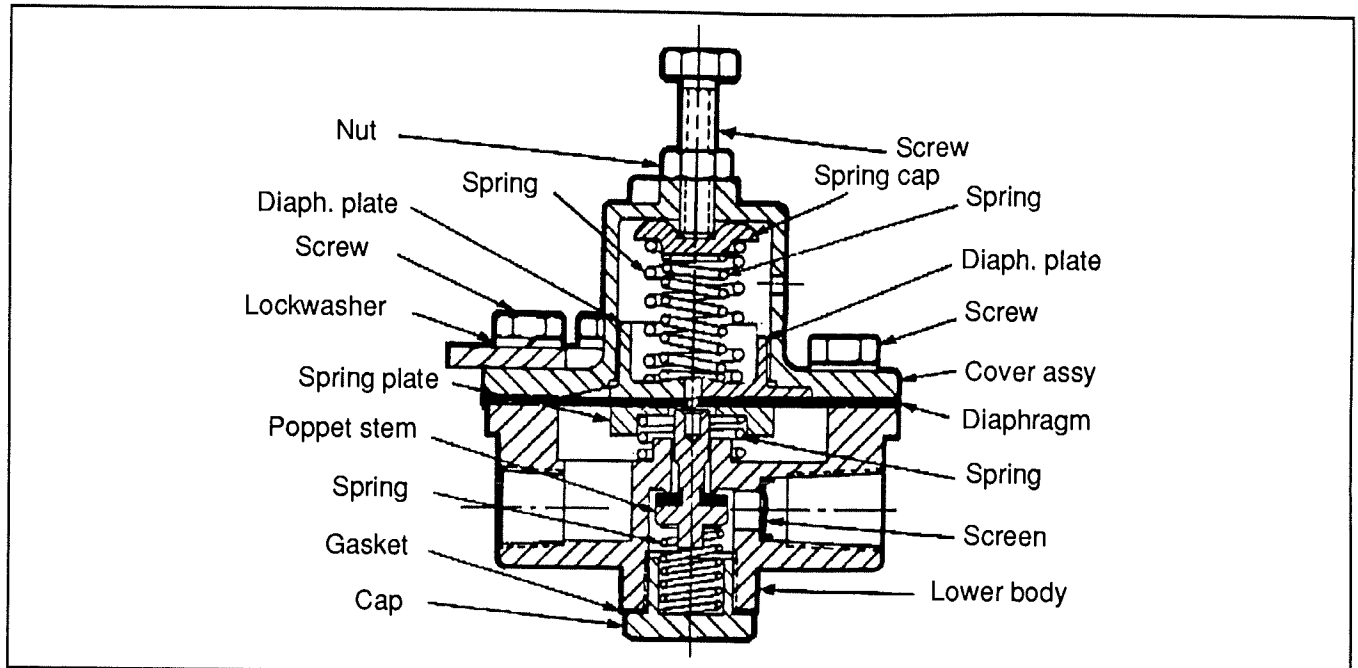

FIG. 15 - Air pressure regulator

MA5-1015.IMG

## Maintenance

Every 50,000 miles (80 000 km) or yearly, check that the mounting bolts and pressure adjusting screw are secure, and there is no air leakage. Disassemble the pressure regulating valve and clean all parts (refer to figure 15 for more details). Replace diaphragm. After valve is assembled, check the pressure setting of the valve with a test gauge. Adjust the valve to the specified pressure setting.

## Testing

A tee fitting and a test fitting are installed in the outlet port of the pressure regulating valve (see figure 16), which enable to adjust or check the pressure regulating valve setting.

## Adjustment

Remove the dust cap from the test fitting. At this test point, use a pressure gauge and check the pressure reading. If the pressure reading is not correct, it can be adjusted by means of the screw on top of the regulating valve as follows:

1. Loosen the locknut, turn the adjusting screw "counterclockwise" to decrease pressure approximately 10 psi (69 kPa) below the required pressure.
2. Turn the adjusting screw "clockwise" to increase the pressure slowly until the required pressure setting is reached. Tighten the locknut.
3. Replace dust cap on the test fitting.

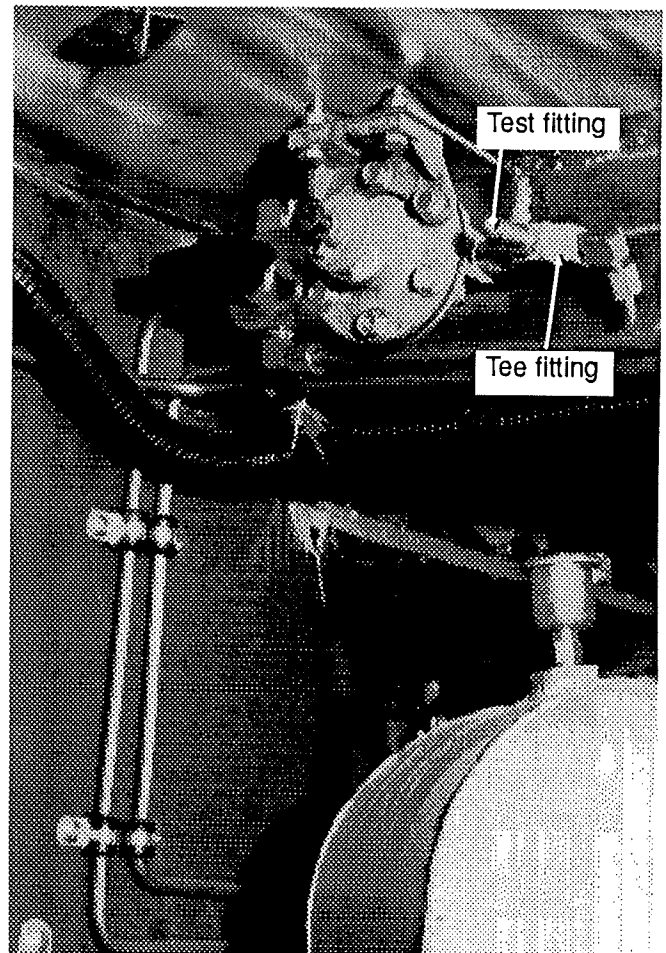

FIG. 16 - Belt tensioner air cylinder pressure regulator

MA5-1014.IMG

## AIR DISC BRAKES

### Description

The axles are provided with Rockwell "Dura-Master" air disc brakes; two different types of rotor are used on the axles. The two front axles and the rear section axle are equipped with solid disc type rotors, (see figure 17) actuated by 20 square inch effective area air brake chambers. As for the drive axles, they are provided with ventilated disc brakes, actuated by 24-30 square inch effective area spring brake chambers. All axles are equipped with standard automatic slack adjusters. Furthermore, from a maintenance point of view, brake pad replacement is much more easier, since only the wheels have to be removed to gain access to the brake pads; the brake pads are identified (inner & outer), and wear indicators are provided to ease inspection.

The manufacturer's brochure (Field Maintenance Manual No 4M), annexed to this section, will give you all the necessary information related to the maintenance of the brakes as well as the brake pad replacement.

## BRAKE PAD REPLACEMENT (SUPPLEMENT)

### Recommendations

Special care must be taken when installing new pads on this vehicle. Follow the instructions hereafter.

1. Before replacing brake pads on the drive axles (axles 3 & 4), you must remove the lower slide pins, and raise caliper so the spring brakes will not interfere with the vehicle sub-frame. Lift the vehicle by its jacking points on the body instead of the axles. This is essential to provide additional space for the caliper clearance.
2. The gap between the pads and the disc must vary between .030" (0,76 mm) and .045" (1,14 mm) on each side of the disc, or between .060" (1,52 mm) and .090" (2,29 mm) for a total gap.
3. After each pad replacement, the pads should have a conditioning ("*burnishing*") in order to reach the normal friction coefficient. This conditioning is obtained by rubbing the pads against the rotor. Perform the procedure hereafter following pad replacement.

### BRAKE PAD CONDITIONING ("*BURNISHING*")

**WARNING:** Proceed with brake pad "*burnishing*" on a road where there is very light traffic, and ensure there is no vehicle following you during this procedure to avoid possible accident.

1. Run the vehicle at an approximative speed of 20 mph (32 km), then apply a moderate pressure on the service brake pedal to decrease speed to 10 mph (16 km). Repeat this operation several times until brake pads overheat and produces smoke.
2. Perform four (4) successive maximum braking applications (vehicle speed must decrease from 20 to 0 mph (32 to 16 km)).
3. Allow pads and discs to cool at least 10 minutes with vehicle cruising at normal speed.

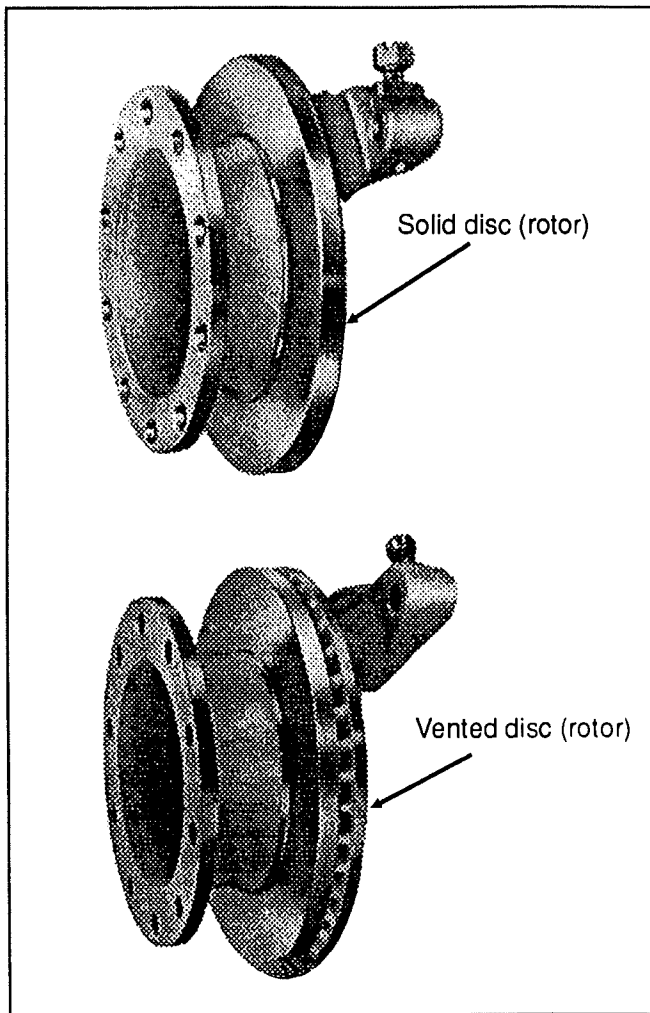

FIG. 17

MASA1017.IMG  
MASB1017.IMG



## RECOMMENDED BRAKE SERVICE PROCEDURES TO REDUCE EXPOSURE TO NON-ASBESTOS FIBER DUST

### Description

Most brake linings no longer contain asbestos fibers. Non-asbestos brake linings use one or more of the following fibers instead of asbestos: fiberglass, mineral wool, aramid, ceramic or carbon. Current OSHA (Occupational Safety and Health Administration) regulations do not cover all non-asbestos fibers. Medical experts do not agree about the possible long term risks of working with and breathing non-asbestos fibers. However, some experts think that long term exposure to some non-asbestos fibers could cause pneumoconiosis, fibrosis and cancer. Therefore, lining suppliers recommend that workers use caution to avoid dust when working on brakes that contain non-asbestos materials.

#### WARNING:

1. Whenever possible, work on brakes in a separate area away from other operations.
2. Always wear a respirator approved by NIOSH (National Institute of Occupational Safety and Health) or MSHA (Mine Safety and Health Administration) during all brake service procedures. Wear the respirator from removal of the wheels through assembly.
3. NEVER use compressed air or dry brushing to clean brake parts or assemblies. OSHA recommends that you use cylinders that enclose the brake. These cylinders have vacuums with high efficiency (HEPA (Health and Environment Protection Agency)) filters and worker's arm sieves. But, if such equipment is not available, carefully clean parts and assemblies in the open air.
4. Clean brake parts and assemblies in the open air. During disassembly, carefully place all parts on the floor to avoid getting dust into the air. Use an industrial vacuum cleaner with an HEPA filter system to clean dust from the brake drums, backing plates and other brake parts. After using the vacuum, remove any remaining dust with a rag soaked in water and wrung until nearly dry.
5. Grinding or machining brake linings. If you must grind or machine brake linings, take additional precautions because contact with fiber dust is higher during these operations. In addition to wearing an approved respirator, do such work in an area with exhaust ventilation.
6. Cleaning the work area. NEVER use compressed air or dry sweeping to clean the work area. Use an industrial vacuum with an HEPA filter and rags soaked in water and wrung until nearly dry. Dispose of used rags with care to avoid getting dust into the air. Use an approved respirator when emptying vacuum cleaners and handling used rags.
7. Worker clean-up. Wash your hands before eating, drinking or smoking. Do not wear your work clothes home. Vacuum your work clothes after use and then launder them separately, without shaking, to prevent fiber dust from getting into the air.
8. Material safety data sheets on this product, as required by OSHA, are available from Rockwell.

### BRAKE RELINE

Refer to "Rockwell Field Maintenance Manual No 4", annexed to this section.

### BRAKE INSPECTION AND OVERHAUL

Refer to "Rockwell Field Maintenance Manual No 4", annexed to this section.

### BRAKE INITIAL ADJUSTMENT

Refer to "Rockwell Field Maintenance Manual No 4", annexed to this section.

### BRAKE LUBRICATION AND PREVENTIVE MAINTENANCE

Refer to "Rockwell Field Maintenance Manual No 4", annexed to this section.

### TROUBLESHOOTING CHART

Refer to "Rockwell Field Maintenance Manual No 4", annexed to this section.

### BRAKE SPECIFICATIONS AND ADJUSTMENTS

Refer to "Rockwell Field Maintenance Manual No 4", annexed to this section.

### AUTOMATIC SLACK ADJUSTER

The manufacturer's brochure ("Field Maintenance Manual No 4B"), annexed to this section, will give you all the necessary information related to the maintenance of this type of slack adjuster.

## ANTI-LOCK BRAKING SYSTEM (ABS)

### Description

This device has been designed to ensure stability and steerability of vehicle during braking, and to minimize its stopping distance whatever the road conditions. On slippery roads and more generally in emergency situations, over braking frequently induces wheel locking. The anti-lock braking system provides maximum braking performance while maintaining adequate steerability on slippery roads.

The ABS monitors continuously the wheel behaviour during braking. Sensors on each wheel of axles 4, and 5 transmit data to a six channel electronic processor which senses when any wheel is about to lock. Modulator valves quickly adjust the brake pressure (up to 5 times per second) to prevent wheel locking. Each wheel is therefore controlled according to the grip available between its tire and the road.

With this device, the vehicle is brought to a halt in the shortest possible time, while remaining stable and under the driver's control.

Just as the vehicle braking system itself has dual circuits, the ABS provides a secondary system should a fault develop in the ABS. Anti-lock systems are fail safe. Should the system cut out due to a malfunction, the braking system reverts to normal non anti-lock controlled operation. But since ABS consists of two diagonally related circuits, only the half system which has sustained damage or other fault is switched off (i.e. wheels return to normal non-ABS braking). The other diagonal half remains under full ABS control.

## ABS COMPONENTS

The main components of the ABS system are listed hereafter. Refer to each component for its specific function in the system and its maintenance.

### Electronic control unit

This control unit is located in the front electric compartment (see "Operator's Manual" for compartment location). According to the data transmitted by the sensors (number of pulses/sec is proportional to the speed of each wheel), the electronic control unit determines which wheel is accelerating or decelerating. It then establishes a reference speed (average speed) from each wheel data, and compares the speed of each wheel with this reference speed to determine which wheel is accelerating or decelerating.

As soon as wheel deceleration or wheel slip threshold values are exceeded, the electronic control unit signals a solenoid control valve to limit the excessive brake pressure produced by the driver in the brake chamber.

### Maintenance

No specific maintenance is required for the electronic control unit. When it is defective, replace it.

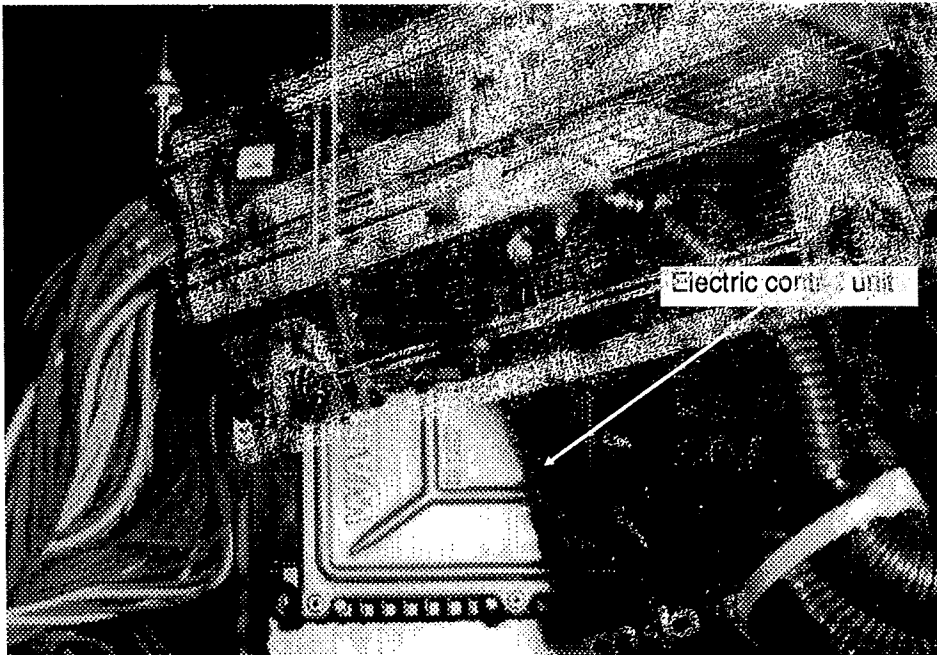

FIG. 18 - Front electric junction box compartment

MA5-1018.JPG

## Solenoid control valve

This ABS system is equipped with six (6) series mounted solenoid control valves, located between the brake chamber and the relay valve (R-12) refer to figure 19. Note that, on the front steering axles and on the drive axles, there is only one (1) valve controlling two wheels on the same side. This is an "On/Off" type valve, i.e., at brake application, the valve exhausts air in the brake chamber when the electronic unit senses that the corresponding wheel speed decreases according to the other wheels.

## Maintenance

Like the electronic control unit, no specific maintenance is required for the solenoid control valve.

## Sensors

The sensors are located on the wheel hubs of the first steering axle, on the second drive axle and on the rear axle according to the following manner: Two on axle 1, two on axle 4 and two on axle 5 (see figure 20). The inductive sensors consist essentially of a permanent magnet with a round pole pin and a coil. The rotation of the toothed wheel alters the magnetic flux picked up by the coil, and thereby produces an alternating voltage, the frequency of which is proportional to the wheel speed. When a wheel has a tendency to decrease due to the braking coefficient, the magnetic flux produced and sensed afterwards by the electronic control unit will be less. Consequently, the electronic control unit will command the solenoid control valve to decrease the pressure at the corresponding brake chamber.

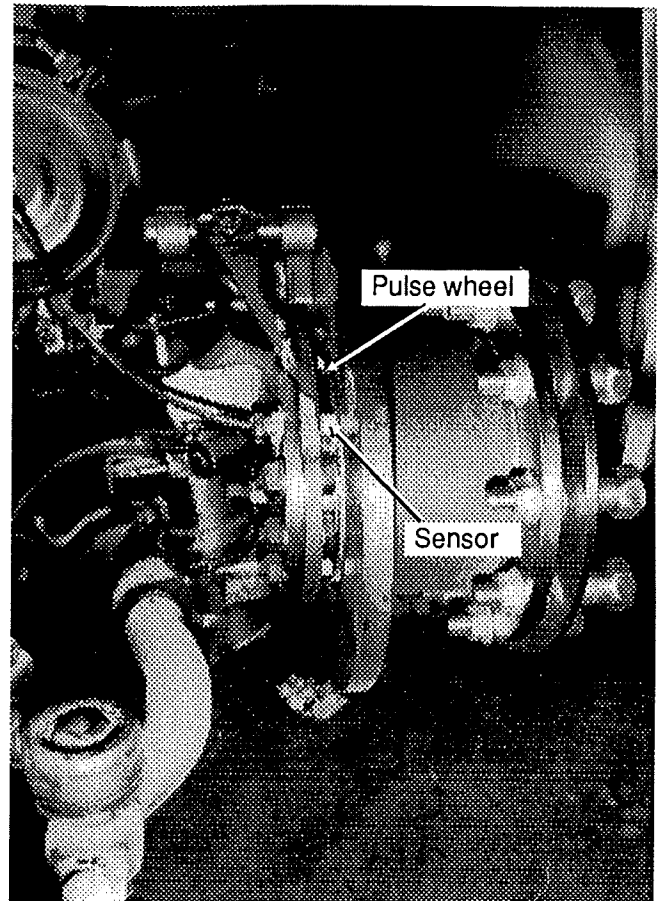

FIG. 20 - Sensor installation on wheel hub

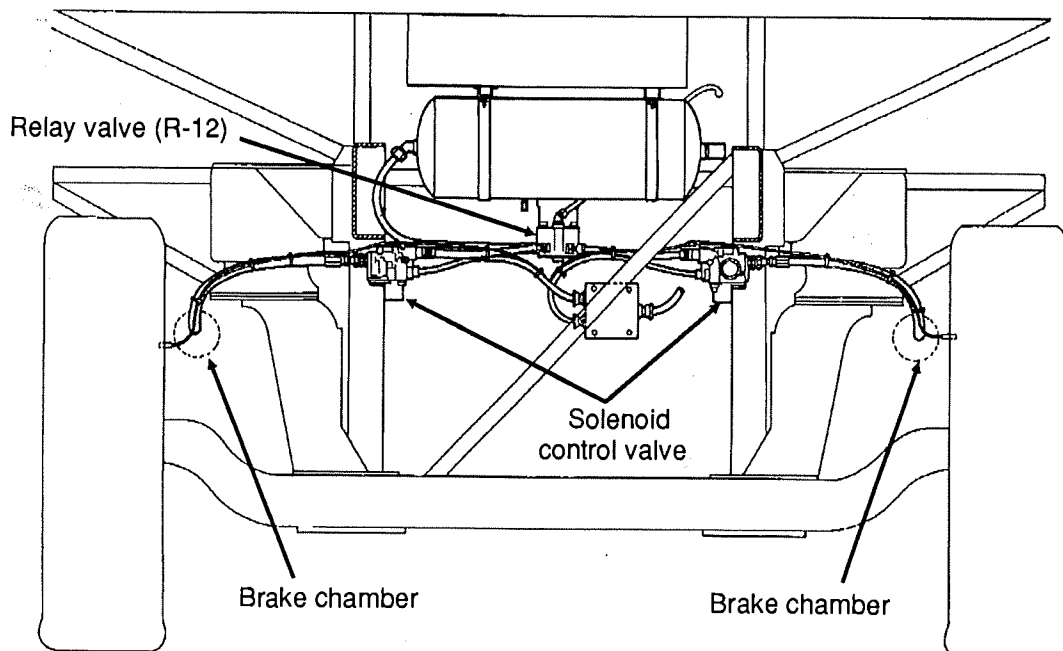

FIG. 19

MA5-1019.IMG

**Maintenance**

No specific maintenance is required for sensors, except if the sensors have to be removed for axle servicing. In such case, sensors should be lubricated with a special grease before their reinstallation. Refer to the "Lubrication chart and service check points" for more details.

**NOTE: The resistance value, when sensors are checked as a unit, must be equal to 1,75 kOhms.**

**SENSOR INSTALLATION**

The following procedure deals with sensor installation on the axle wheel hubs. Read procedure carefully before reinstalling a sensor, as its installation must comply with operational tolerances and specifications. Sensor and pulse wheel installation varies with axle design; figure 21 illustrates installation of sensors on axles 1 & 5, and figure 22 on axle 4. Refer to the appropriate figure for details.

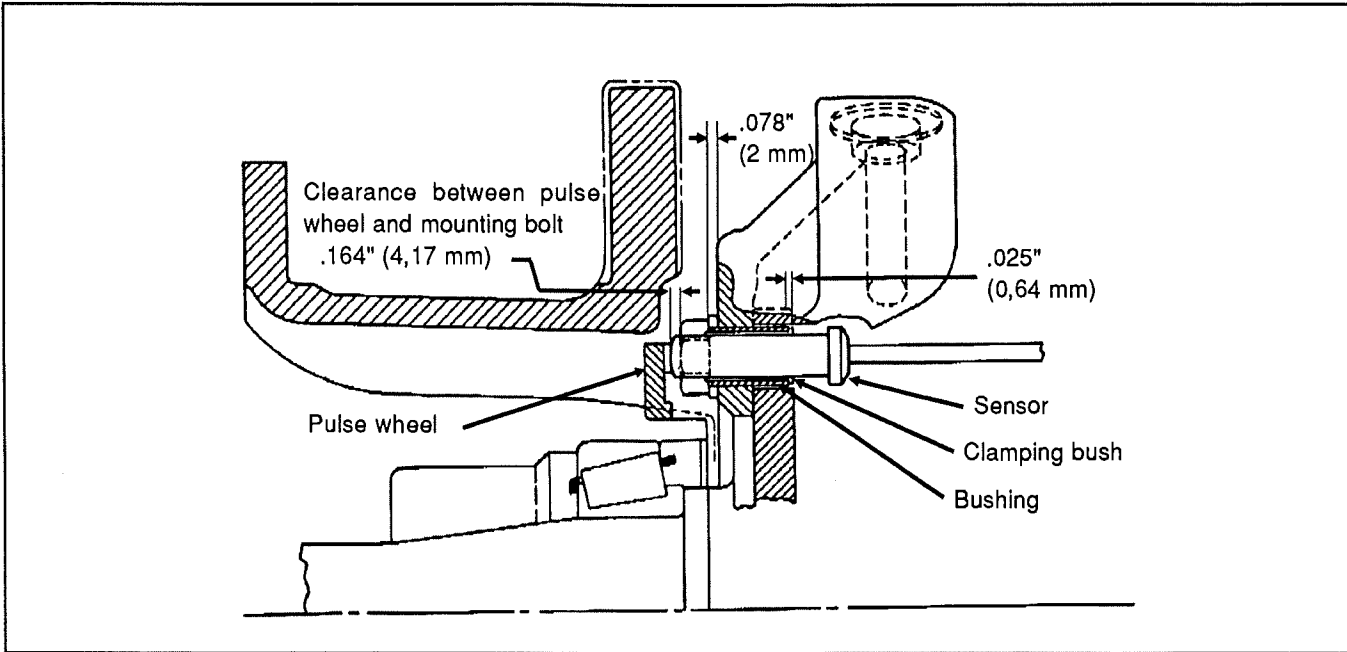

FIG. 21 - Sensor installation on axles 1 and 5

MA5-1026.IMG

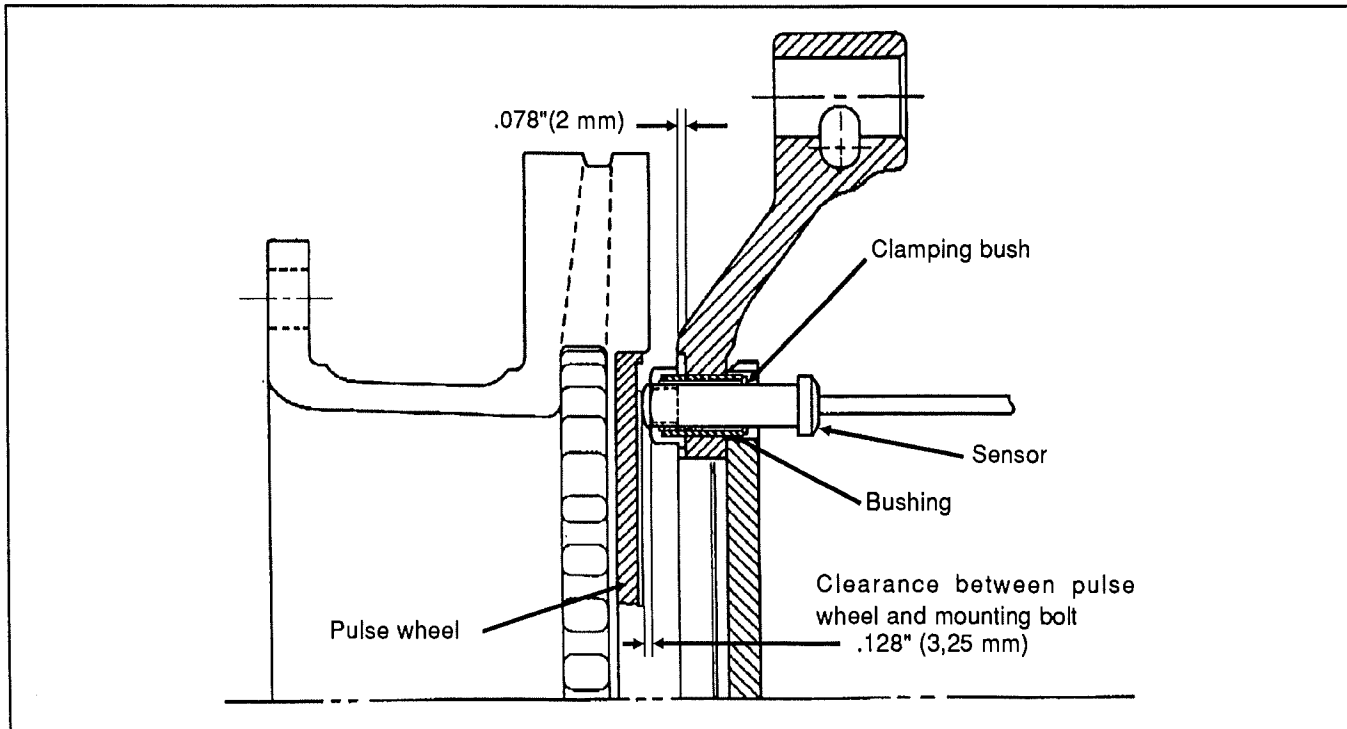

FIG. 22 - Sensor installation on axle 4

MA5-1027.IMG

1. Dip clamping bush into the special grease (Prévost part number #68-0460), press clamping bush and insert in the bushing on hub.

**CAUTION:** Use only this type of grease on the sensors.

2. Install sensor inside the clamping bush, then push on assembly to seat it on the pulse wheel. Ensure mounting is rigid, as it is an important criterion for a good sensor operation.

**NOTE:** This installation should be of the "press fit" type.

### Clamping bush

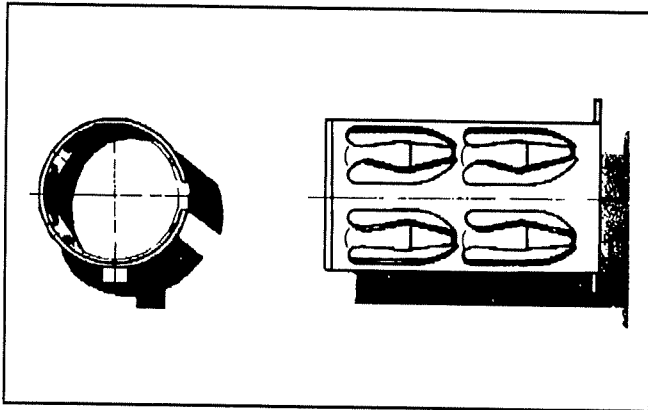

FIG. 23 - Clamping bush

MAS-1021.IMG

The clamping bush retains the sensor in its mounting bracket close to the toothed pole wheel. The gap between the sensor end and teeth is set automatically by pushing the sensor in its bush hard up against the pole wheel, and the latter knocks back the sensor to its adjusted position.

### Maintenance

The clamping bush requires no specific maintenance.

## ABS TEST EQUIPMENT

Testing the Anti-lock Braking System is made easy with the specially developed test device. Wabco's manual of step by step test instructions provides a schedule for routine checking or diagnostic tests, in the event of a malfunction being indicated by the vehicle warning light.

Each page explains to the technician what is being tested, which buttons on the test unit should be pressed and the correct digital display. An incorrect reading indicates the area of the fault. The electronic control unit is self checking; the functioning of all other components and the integrity of the wiring is checked by the test device.

Refer to "Wabco, Step by Step Test Instructions" manual which is supplied when ordering "Test Unit" from supplier.

# SPECIFICATIONS

## TIGHTENING TORQUES FOR FITTINGS

**1. 45° flare and inverted flare:** Tighten assembly with a wrench until a solid feeling is encountered. From that point, tighten a 1/6 turn.

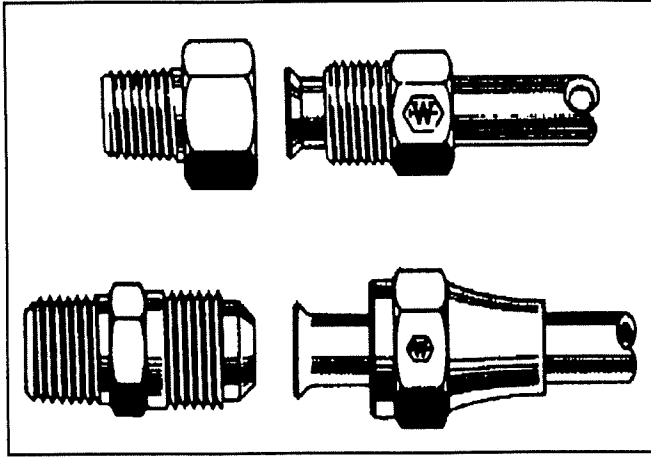

MA5-1022.IMG

**2. Compression:** Tighten nut hand tight. From that point, tighten with a wrench the number of turns indicated in the chart hereafter.

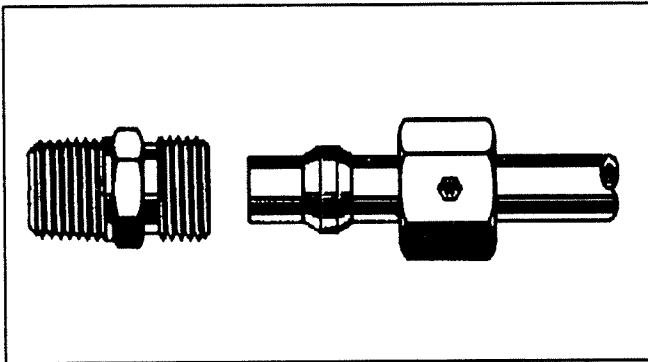

MA5-1023.IMG

Fitting size	Pipe diameter	Number of additional turns required following manual tightening
2	1/8"	1 1/4
3	3/16"	1 1/4
4	1/4"	1 1/4
5	5/16"	1 3/4
6	3/8"	2 1/4
8	1/2"	2 1/4
10	5/8"	2 1/4
12	3/4"	2 1/4
16	1"	2 1/4

**3. NTA-type plastic tubing:** Tighten nut hand tight. From that point, tighten with a wrench the number of turns indicated in the chart hereafter.

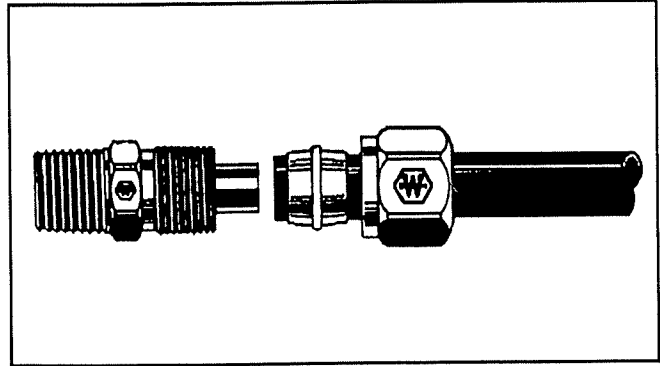

MA5-1024.IMG

Tubing diameter	Number of additional turns required following manual tightening
1/4"	3
3/8 to 1/2"	4
5/8 to 3/4"	3 1/2

**4. AB-type copper piping:** Tighten nut hand tight. From that point, tighten with a wrench the number of turns indicated in the chart hereafter.

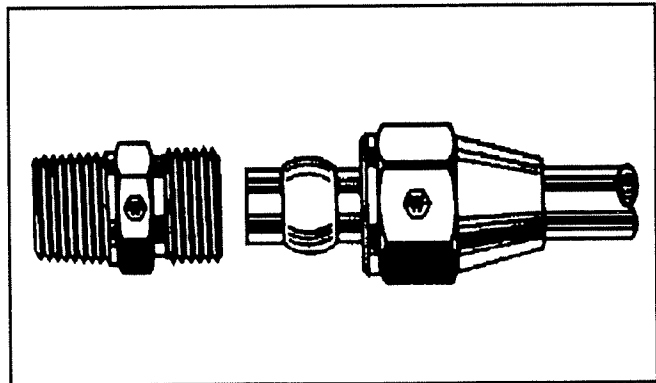

MA5-1025.IMG

Piping diameter	Number of additional turns required following manual tightening
1/4", 3/8", 1/2"	2
5/8", 3/4"	3

**5. Piping tightening:** All connections must be tightened hand tight. From that point, tighten a minimum of 2 1/2 additional turns.

**AIR COMPRESSOR**

Make . . . . . Bendix Westinghouse  
 Model . . . . . Tu-Flo 700  
 Supplier Number . . . . . 289868  
 Prévost Number . . . . . 64-0937  
 Capacity (at 1250 rpm) . . . . . 15.5 cu.ft. (439 m<sup>3</sup>)

*min* *max*

**GOVERNOR**

Make . . . . . Bendix Westinghouse  
 Model . . . . . D-2  
 Supplier Number . . . . . 284358  
 Prévost Number . . . . . 64-0964  
 Cut-in pressure . . . . . .95-105 psi (655-724 kPa)  
 Cutout pressure . . . . . 120-125 psi (827-861 kPa)

**PUSH-PULL CONTROL VALVE (Parking Brakes)**

Make . . . . . Bendix Westinghouse  
 Model . . . . . PP-1  
 Supplier Number . . . . . 287325  
 Prévost Number . . . . . 64-1128  
 Automatic release pressure . . . . . 40 psi (275 kPa) nominal

**DUAL BRAKE APPLICATION VALVE**

Make . . . . . Bendix Westinghouse  
 Model . . . . . E-10  
 Supplier Number . . . . . 101270  
 Prévost Number . . . . . 64-1122

**BRAKE RELAY VALVES**

Make . . . . . Bendix Westinghouse  
 Model . . . . . R-12H  
 Supplier Number . . . . . 102852  
 Prévost Number . . . . . 64-1088

Make . . . . . Parker Hannifin Canada Ltd.  
 Model . . . . . R-14  
 Supplier Number . . . . . 102858  
 Prévost Number . . . . . 64-1120

**COMBINED STOP LIGHT SWITCH WITH DOUBLE CHECK VALVE**

Make . . . . . Bendix Westinghouse  
Model . . . . . DS-2  
Supplier Number . . . . . 286445  
Prévost Number . . . . . 64-1123

**LOW PRESSURE INDICATOR**

Make . . . . . Bendix Westinghouse  
Model . . . . . LP-3  
Supplier Number . . . . . 276599  
Prévost Number . . . . . 64-1174  
Contact close . . . . . 30 ± 3 psi (206 ± 20 kPa)

**SHUTTLE TYPE DOUBLE CHECK VALVE**

Make . . . . . Bendix Westinghouse  
Model . . . . . DC-4  
Supplier Number . . . . . 277988  
Prévost Number . . . . . 64-1015

**PRESSURE PROTECTION VALVE**

Make . . . . . Bendix Westinghouse  
Model . . . . . PR-4  
Supplier Number . . . . . 288323  
Prévost Number . . . . . 64-1137  
Nominal closing pressure . . . . . 70 psi (482 kPa)

**AIR DRYER**

Make . . . . . Bendix Westinghouse  
Model . . . . . AD-4  
Supplier Number . . . . . 103386  
Prévost Number . . . . . 64-1138  
Dessicant cartridge kit Supplier Number . . . . . 103981  
Dessicant cartridge kit Prévost number . . . . . 64-1139

**AIR PRESSURE REGULATOR**

Make . . . . . Williams Air Controls  
Supplier Number . . . . . WM-279-E1  
Prévost Number . . . . . 64-0938  
Adjustable output range . . . . . 0-80/85 psi (0-552/586 kPa)  
Maximum output . . . . . 85 psi (586 kPa)



**PNEUMATIC AIR FILTER**

Make . . . . . Norgren  
Model . . . . . F12  
Supplier Number . . . . . F12-300-M3D  
Prévost Number . . . . . 64-1135

**FRONT BRAKE CHAMBER (Axles 1 & 2)**

Make . . . . . Rockwell  
Type . . . . . 20  
Effective Diaphragm Area . . . . . 20 sq.in. (129 sq.cm)  
Supplier Number . . . . . V30-3276-T-20  
Prévost Number . . . . . 61-0886

**DRIVE BRAKE CHAMBER (Axle 3 & 4)**

Make . . . . . Rockwell  
Type . . . . . 24-30  
Effective Diaphragm Area . . . . . 24 sq.in. (154.8 sq.cm) as service  
.30 sq.in . (193.5 sq.cm) as emergency  
Supplier Number . . . . . K2-3276-X-24  
Prévost number . . . . . 61-0885

**REAR BRAKE CHAMBER (Axle 5)**

Make . . . . . Rockwell  
Type . . . . . 20  
Effective Diaphragm Area . . . . . 20 sq.in. (129 sq.cm)  
Supplier Number . . . . . V30-3276-T-20  
Prévost Number . . . . . 61-0886

**KIT SHOE AND LINING ASSY (Axles 1, 2 & 5)**

Make . . . . . Rockwell  
Supplier Number . . . . . 15409 RM  
Prévost Number . . . . . 61-0841

**KIT SHOE AND LINING ASSY (Axles 3 & 4)**

Make . . . . . Rockwell  
Supplier Number . . . . . 15612 RM  
Prévost Number . . . . . 62-1371

**AUTOMATIC SLACK ADJUSTER**

Make . . . . . Rockwell  
Supplier Number (L.H. side) . . . . . A29-593-86TB-051  
Prévost Number (L.H. side) . . . . . 61-0881  
Supplier Number (R.H. side) . . . . . A29-599-86TB-077  
Prévost Number (R.H. side) . . . . . 61-0880

**SOLENOID CONTROL VALVE (ANTI-LOCK BRACKING SYSTEM)**

Make . . . . . Wabco  
Supplier Number . . . . . 472 195 006 0  
Prévost Number . . . . . 64-1097



# 11

# WHEELS, HUBS AND TIRES

---

## CONTENTS OF THIS SECTION

DESCRIPTION .....	11-1
WHEEL NUT TIGHTENING PROCEDURE .....	11-1
WHEEL MAINTENANCE .....	11-1
WHEEL STUDS .....	11-2
SPARE WHEEL .....	11-2
FRONT AND REAR AXLE WHEEL HUBS .....	11-3
DRIVE AXLE WHEEL HUBS .....	11-3
TIRE MAINTENANCE .....	11-4
TIRE MATCHING .....	11-5
WHEEL AND TIRE BALANCING .....	11-5
TIRE ROTATION .....	11-6



# 11 WHEELS, HUBS AND TIRES

## DESCRIPTION

This vehicle is equipped with stud-mounted wheels on all axles. Wheel studs and nuts on left side of vehicle have left-hand threads, while wheel studs and nuts on right side of vehicle are provided with right-hand threads. The vehicle is provided with standard steel wheels, and aluminum polished wheels are available as optional equipment.

Both steel and aluminum wheels are 22.50 x 8.25" (571,5 x 209,5 mm) for the following recommended tires:

- Firestone: 315/80 R 22.5
- Goodyear: 12.75 R 22.5
- Michelin: XZA12 R 22.5 or 315/80 R 22.5
- Yokohama: 12 R 22.5

## WHEEL NUT TIGHTENING PROCEDURE

It is important that wheel nuts be tightened alternately on opposite sides of wheel. Refer to figure 1 for recommended tightening sequence and to the following procedure.

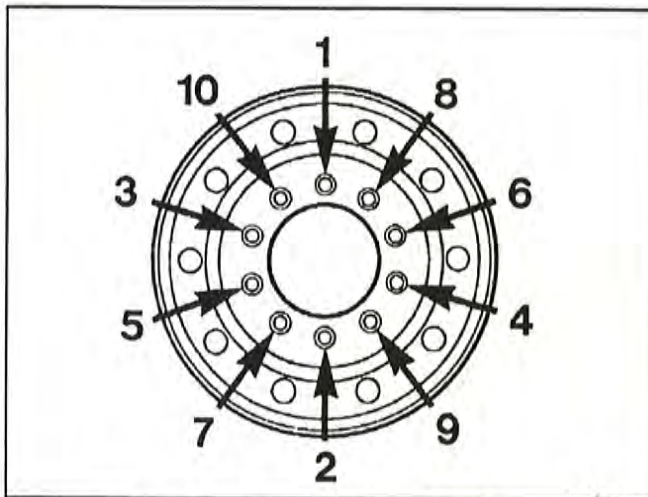

FIG. 1 - Wheel nut tightening sequence

1. Run in lightly the wheel nuts referring to figure 1 for sequence, so that wheel will position itself concentrically with hub. This is important, otherwise wheel may be eccentric with hub and will not run concentric. In this initial step, run the nuts up only as necessary to correctly position wheel.

2. Tighten wheel nuts progressively as shown in figure 1. The final tightening should be done with a torque wrench. Tighten wheel nuts to 450 - 500 ftlbs (610 - 678 Nm) for aluminum as well as steel wheels.

## WHEEL MAINTENANCE

Wheel maintenance consists of periodic inspections to ensure that wheel nuts are tightened to the proper torque. In the case of a new vehicle, or after a wheel installation, wheel nuts should be tightened every 100 miles (160 km) for the first 500 miles (800 km) to allow setting in of clamping surfaces.

Wheel studs and nuts must be kept free from grease and oil. No lubricant whatsoever should be used. Cleanliness of wheel and rotor mating surfaces is important for proper wheel mounting.

## Corrosion protection of aluminum wheels

1. Clean wheels often by means of a high pressure water jet. Cleaning may be accelerated with mild soap. Do not use concentrated alkaline cleaning products.

2. When tire is removed, clean and inspect wheel completely. Remove foreign matters on rim by means of a wire brush. Do not use a wire brush to remove dirt and corrosion on the outer surface of wheel.

3. Take the following measures to maintain original appearance of the aluminum wheels:

a. Use a sponge, a soft cloth, or a soft fiber brush, and a mild soap and warm water solution to wash the wheel outer surfaces.

b. Rinse thoroughly with clean water.

c. Wipe and dry thoroughly to prevent water stains.

d. Wax surface with "Simonize Body Guard", "Dupont 7 New Car Wax", or an equivalent product.

e. Clean aluminum wheels as required to maintain original look.

**WARNING:** Wheel surfaces may have sharp or cutting edges which may cause injuries to the hands. To prevent contacting sharp edges, it is strongly recommended to wear rubber gloves when washing or polishing wheels.

## Checking for distorted wheel on vehicle

1. Raise axle at side to be checked and place a safety support underneath.

2. Check the rim for lateral runout. Install a dial gauge as shown in figure 2, then rotate the wheel one full turn. As the wheel turns, note any variation on the dial gauge.

**CAUTION:** Take care not to damage the dial gauge as it may interfere with the weights of the wheel.

3. The variation should not exceed .125" (3 mm). If the rim is distorted beyond this dimension, the wheel must be replaced.

4. If doubt exists whether wheel or hub is distorted, hub may be checked as follows:

Replace the existing wheel with a wheel known to be correct. Revolve the wheel and make the previously mentioned tests. If tests are within limits, the hub is satisfactory, but the wheel is sprung.

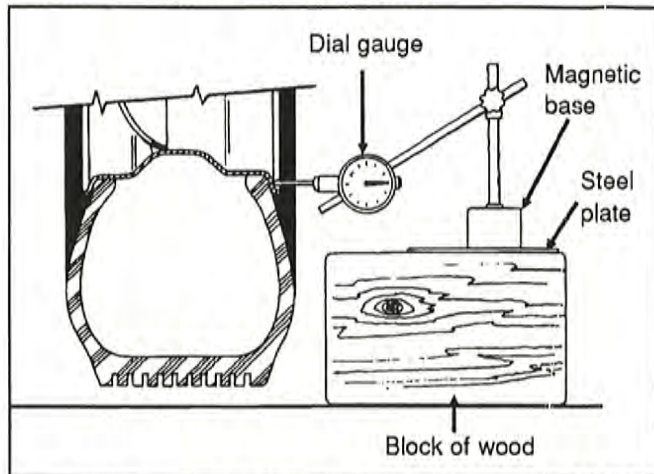

FIG. 2 - Suggested dial gauge installation

## WHEEL STUDS

Stripped threads may be the result of excessive torquing, or a result of damage during wheel installation, when placing the wheel over the studs. Where a damaged thread is discovered, the stud must be replaced. Broken studs are a direct result of operating with loose stud nuts or improperly seated wheels. When a broken stud is replaced, the adjacent studs on each side of the broken stud must also be replaced because they could have been subjected to excessive strain and may have become fatigued.

When installing wheel studs to hubs, check nuts retaining the wheel stud to wheel hub and if they are deformed, damaged or severely corroded, install new parts. Install nut to new stud and torque to 110 - 130 ftlbs (150 - 177 Nm).

## SPARE WHEEL

The spare wheel is stored under vehicle in back of rear section. A winch located in the lavatory tank compartment is provided to ease removal and installation of spare wheel. Refer to figure 3 for winch and spare wheel assembly installation.

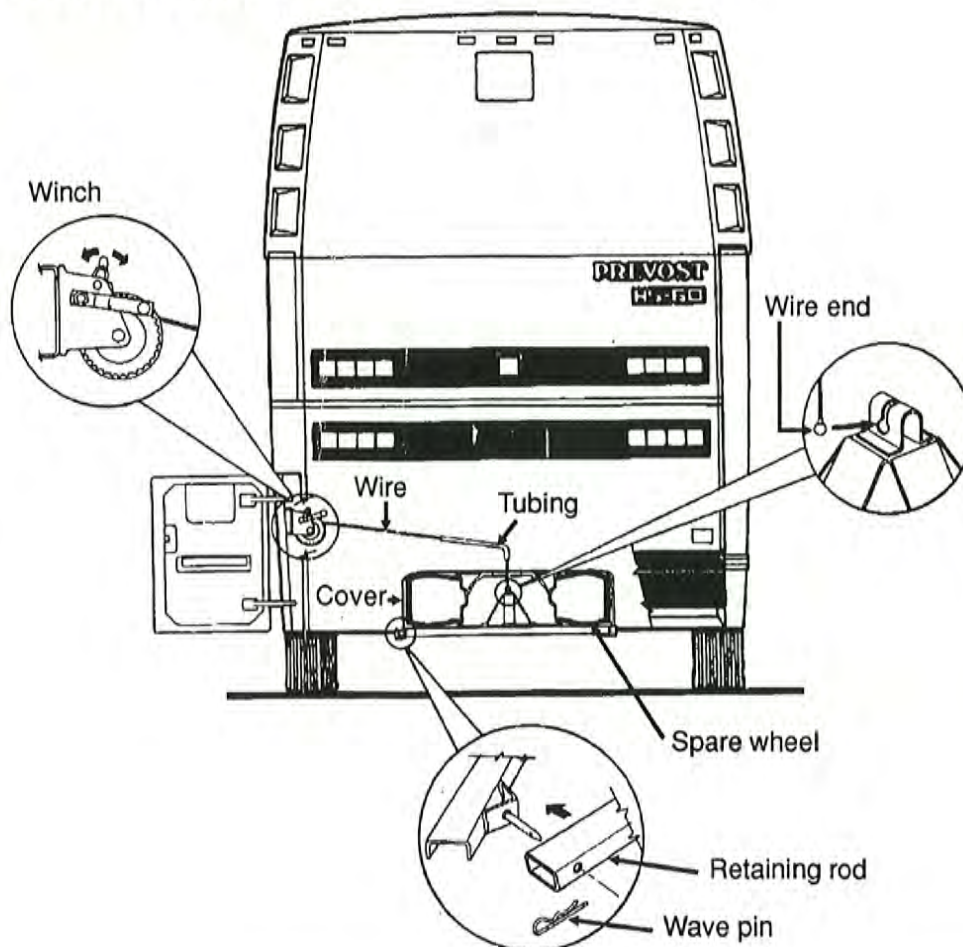

FIG. 3

MA5-1104.IMG

## Spare wheel maintenance

Maintenance of spare wheel consists in ensuring that tire is inflated to the recommended pressure: 115 psi (790 kPa). Check rim also to ensure there is no important corrosion, then check if spare wheel cover is in good condition.

**CAUTION:** If spare wheel must be installed elsewhere than on a drive axle, deflate tire to the recommended pressure as outlined under heading "*Recommended tire inflation pressure*".

## Winch maintenance

Once a year, apply molybdenum disulphide grease on winch gears, ratchet mechanism, rotating shafts and wire. To grease the section of wire inside the tubing, it is necessary to lower the spare wheel on ground; proceed as follows:

1. Open lavatory tank access door at rear end on L.H. side of vehicle, then locate the winch (see fig. 3).
2. Crank winch to support spare wheel weight.
3. From under vehicle, remove wave pin and spare wheel retaining rod (see fig. 3).

**WARNING:** Never work under vehicle if retaining rod is not securely in place.

4. Release winch and lower spare wheel on ground.

Reverse removal procedure to reinstall spare wheel.

**NOTE:** To avoid undesirable movement of spare wheel, crank winch until wheel seats against compartment wall, then crank winch two additional notches to increase pressure of wheel against compartment wall. If winch handle interferes with compartment door, remove handle retaining nut, handle, then position handle on the opposite side, i.e. 1/2 turn further, and fix it with the nut removed previously.

## FRONT AND REAR AXLE WHEEL HUBS

### Description

Front and rear axle wheel hubs use oil lubrication which eliminates periodic repacking of the hubs. A sight glass is provided for convenient check of oil level. Level should be checked daily. If oil is not visible through the sight gauge, general purpose gear lubricant SAE 90 (A.P.I. spec GL5) must be added through the snap plug hole at the center of the hub cap to bring oil to the correct level.

## Maintenance

For the maintenance of the wheel hub bearing, refer to "*Rockwell Field Maintenance Manual no. 2*" entitled "*Non-Driving Front Axles*", annexed to the end of section 07 in this maintenance manual.

## DRIVE AXLE WHEEL HUBS

### Description

Drive wheels use a single oil-seal assembly and are lubricated from the oil supply in the differential housing. Bearings are tapered roller, adjustable to compensate wear. Maintain differential oil levels with general purpose gear lubricant (refer to "*Lubrication Chart*" in section 19 for proper oil grade selection) to ensure adequate oil supply to wheel bearings at all times.

### Bearing adjustment

To adjust drive wheel bearings, raise vehicle by axle #3 jacking points (front drive axle), until both wheels on axle #4 (rear drive axle) may be turned freely (approximately 6" from ground). Position jack stands under axle #4, then lower vehicle approximately 2" in order to avoid that entire weight of the axle be supported by the suspension air bellows and the shock absorber pins.

**CAUTION:** Never lift vehicle by rear drive axle as it may damage suspension components.

**CAUTION:** Never exceed a twelve degree (12°) angle or thirty-six inches (36") between front and rear sections when jacking vehicle.

Remove axle shaft as indicated in "*Rockwell Field Maintenance Manual no. 5P*" entitled "*Tandem Axle Forward Rear Drive Units*" annexed to the end of section 08 in this maintenance manual. Remove gaskets. Unscrew lock nut and remove adjusting nut lock ring.

To adjust, tighten adjusting nut until the wheel binds, rotate the wheel while tightening so that all surfaces are in proper contact. Back off adjusting nut approximately 1/8 turn to ensure that wheel turns freely. Replace lock ring, and adjust nut dowel pin in one of the holes. The ring may be turned over if necessary to allow more accurate adjustment of bearings. Tighten lock nut and recheck bearing adjustment. Replace the axle shaft using a new gasket.

### Disassembly and repair

Jack vehicle as outlined above under heading "*Bearing adjustment*" and remove axle shaft as indicated in "*Rockwell Field Maintenance Manual no. 5P*" entitled "*Tandem Axle Forward Rear Drive Units*" annexed to the end of section 08 in this maintenance manual. Remove wheels and tires.



**CAUTION:** Always mark the position of the wheel on the axle prior removal, so you can replace wheel at the same location, thus avoiding a new balancing of wheel.

Swing away caliper as indicated in "Rockwell Field Maintenance Manual no. 4M" entitled "Dura-Master Air Disc Brakes" annexed to the end of section 10 in this maintenance manual. Remove lock nut, lock ring and adjusting nut from axle housing, taking care to prevent the outer bearing from falling out. Remove outer bearing cone and roller assembly. Remove screws attaching inner oil seal retainer to hub, and remove inner oil seal assembly. Remove inner bearing cone and roller assembly. Bearing cups can be removed from the hub using a hammer and a long brass drift.

All parts should be thoroughly cleaned. Bearing cone and roller assemblies can be cleaned in a suitable cleaning solvent using a stiff brush to remove old lubricant.

If excessive wear, deterioration, cracking, or pitting are present on the bearing cups, rollers, or cones, the bearings should be replaced. Seals should be replaced every time they are removed from the hub. To install new oil seal, use a suitable adapter and drive the seal into the retainer bore until it bottoms.

When installing wheel on spindle, center the wheel hub with spindle to avoid damaging the seal with end of the spindle. Push wheel straight over the spindle until inside diameter of seal pressfits on wiper ring. Pre-fill hub cavity with general purpose gear lubricant (refer to

"Lubrication Chart" in section 19 for proper oil grade selection). Lubricate outer bearing cone and assemble. Adjust bearing and lock. Assemble axle flange to axle using a new gasket. Apply sealant in stud area. After both wheels have been assembled according to above procedure, fill the differentials to the proper factory recommended level. Clean vent thoroughly.

## TIRE MAINTENANCE

The most critical factor in tire maintenance is proper inflation. No tire is completely impervious to loss of air pressure. To avoid the hazards of underinflation, lost air must be replaced.

**WARNING: Driving on any tire that does not have the correct inflation pressure is dangerous and will result in tire damage.**

Any underinflated tire builds up excessive heat that may result in sudden tire destruction. Check inflation pressures on all the tires, including spare, at least once a week before driving when tires are cold. This is especially important in cases where vehicle is operated by more than one driver.

**WARNING: Failure to maintain correct tire inflation pressure may result in sudden tire destruction, improper vehicle handling, and will cause rapid and irregular tire wear. Therefore, inflation pressures should be checked weekly and always before long distance trips.**

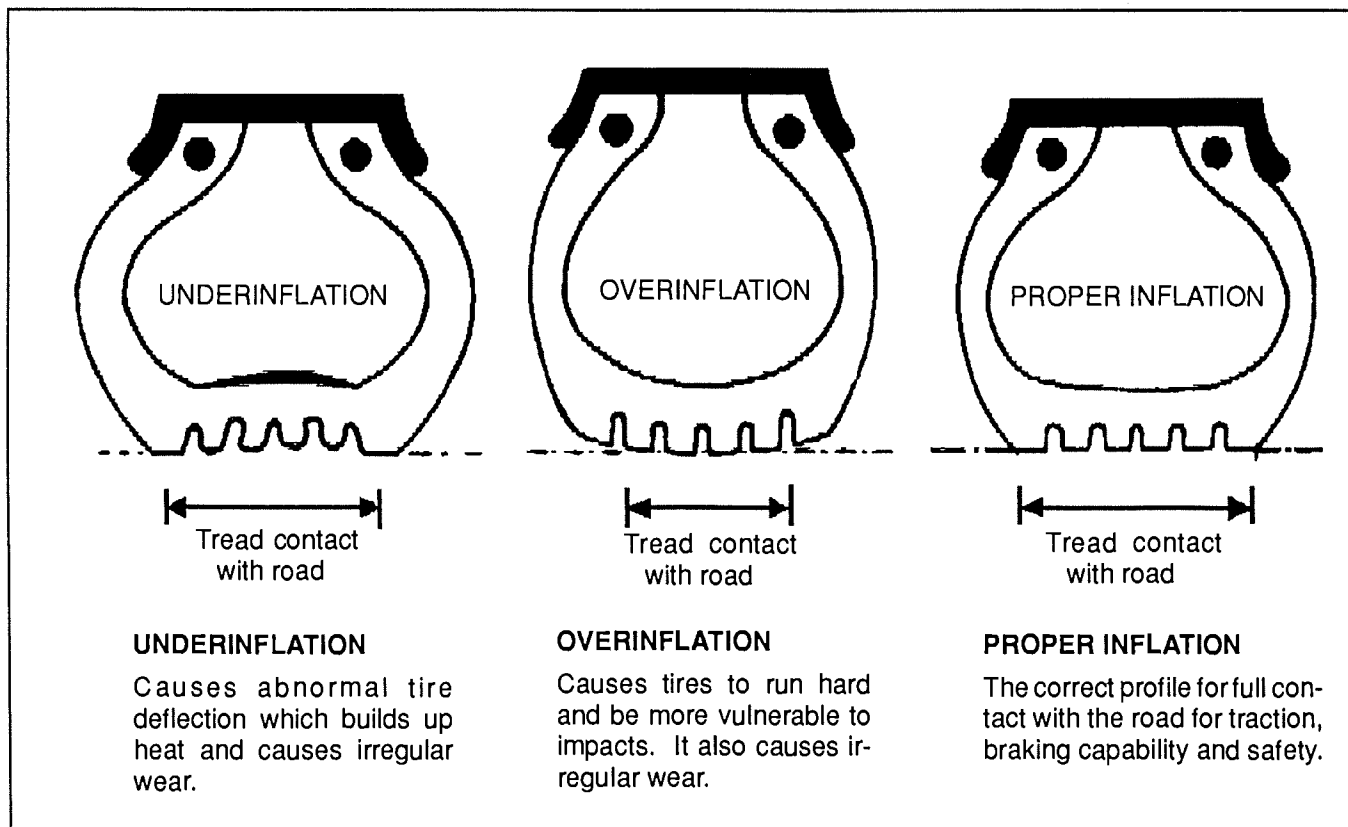

FIG. 4

MA5-1103.IMG

Pressures should be checked when tires are cold; in other words, before they have been driven on. Driving, even for a short distance, causes tires to heat up and air pressures to increase.

Never bleed air from hot tires as tires will then be underinflated. Use an accurate tire gauge to check pressures. (Do not hit tires as an inflation check; this is an unreliable method).

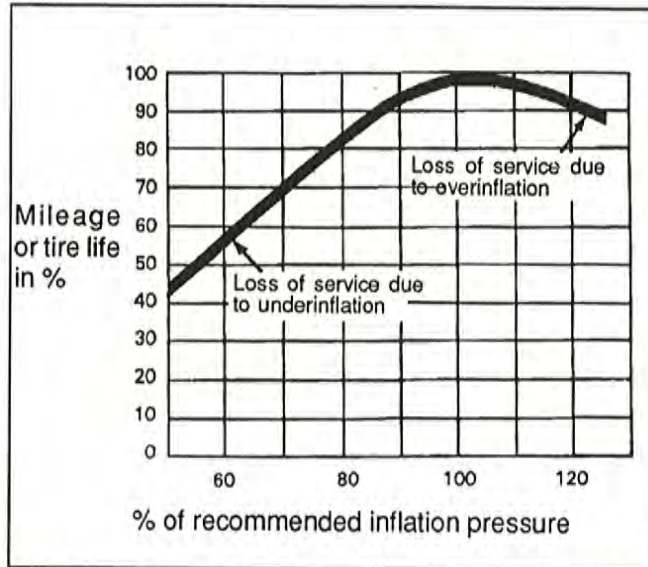

FIG. 5 - Effects of inflation pressure on tire life

## Recommended tire inflation pressure (cold)

Rear section axle: 105 psi (725 kPa)

Drive axles: 115 psi (790 kPa)

Steering axles: 100 psi (690 kPa)

## TIRE MATCHING

Unmatched tires on drive axles will cause tire wear and scuffing, as well as possible damage to the drive units. Consequently, we recommend that tires be matched within 1/8" of the same rolling radius, and 3/4" of the same rolling circumference.

**CAUTION:** The four drive axle tires must have identical specifications as regards diameter and width; different tire specifications will cause an inter-axle "fight", unusually high axle lubricant temperatures, that result in premature lubricant breakdown, and possible costly axle service.

**CAUTION:** Keep tires inflated at the recommended air pressure, so the lubricant temperature of both axles is within 30 °F (18 °C) of each other and not in excess of 200 °F (93 °C). This will usually result in uniform tire loading and good tire life.

## WHEEL AND TIRE BALANCING

Balance tires on vehicle following the equipment manufacturer's instructions carefully. Balance drive axle tires as follows:

1. Raise vehicle sufficiently by its jacking points on the body (see section 17 "body" under heading "Vehicle jacking points") so that wheels do not touch the ground, install balancing equipment under the wheel, then chock the three other drive axle wheels.

2. Be sure the differential lock control is set to the "unlock" position.

**WARNING:** Do not attempt to balance a tire with the differential lock control set to the "lock" position, since the vehicle may move through the other drive axle wheels.

3. With engine running, release the parking brake, select second range of transmission, then balance the wheel by spinning it to a maximum of 17 mph (27 km/h) as indicated on the speedometer.

**WARNING:** This speed limit is necessary because speedometer indicates only a quarter of the actual wheel speed when the three other drive wheels are stopped. Unless care is taken in limiting drive wheel spinning, the spinning wheel can reach excessive speeds, resulting in possible tire damage or differential failure, which could cause personal injury or extensive vehicle damage.

**CAUTION:** When wheel balancing, a maximum of 16 ounces in weights may be required for each wheel; however, if more than 16 ounces are required on a wheel, check and correct cause.

## TIRE ROTATION

Tires should be interchanged at 25,000 mile (40 000 km) intervals to ensure maximum tire life. When the running-position of radial tires is changed, the direction of tire rotation should not be reversed. Refer to figure 6 for the recommended tire rotation pattern.

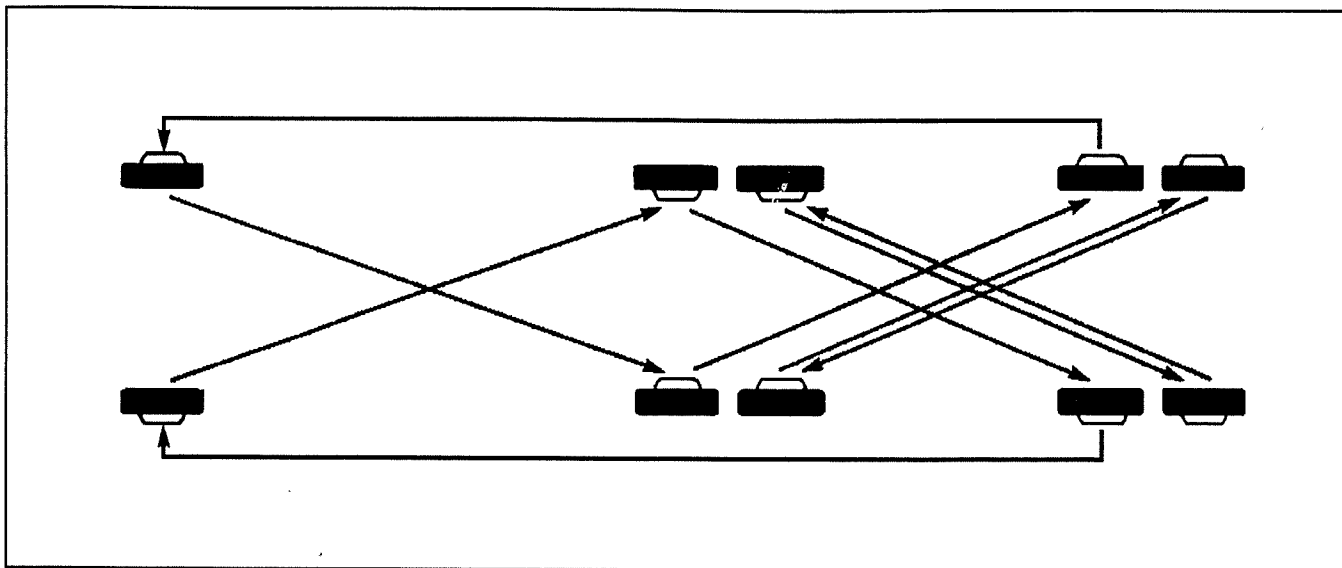

FIG. 6 - Tire rotation pattern

MA5-1106.JPG

**CAUTION:** The direction of radial tire rotation should never be reversed.



# 12

# STEERING SYSTEM

---

## CONTENTS OF THIS SECTION

DESCRIPTION . . . . .	12-1
OPERATION . . . . .	12-1
MAINTENANCE . . . . .	12-2
POWER STEERING GEARBOX . . . . .	12-3
BLEEDING POWER STEERING HYDRAULIC SYSTEM . . . . .	12-3
HYDRAULIC PRESSURE TEST . . . . .	12-3
TROUBLESHOOTING . . . . .	12-3
TROUBLESHOOTING CHECK LIST . . . . .	12-3
POWER STEERING HYDRAULIC PUMP . . . . .	12-3
HYDRAULIC OIL TANK . . . . .	12-3
HYDRAULIC OIL TANK STRAINERS . . . . .	12-4
HYDRAULIC OIL FILTER . . . . .	12-5
STEERING WHEEL . . . . .	12-5
STEERING COLUMN . . . . .	12-5
TURNING ANGLE ADJUSTMENT . . . . .	12-7
STEERING LINKAGE ADJUSTMENT . . . . .	12-7
PITMAN ARM . . . . .	12-7
REAR AXLE STEERING CONTROL . . . . .	12-7
POWER STEERING CYLINDER . . . . .	12-7
STEERING DAMPER . . . . .	12-7
LUBRICATION . . . . .	12-7
SPECIFICATIONS . . . . .	12-8



# 12 STEERING SYSTEM

## DESCRIPTION

This vehicle is provided with a HFB-70 integral power steering gearbox which steers the tandem front axles. It is assisted by a hydraulic steering cylinder mounted on the second axle. The steering system has its own gear driven hydraulic pump, but shares the hydraulic oil tank and return line filter with the condenser fan hydraulic system. To see the interrelation between the power steering system and the condenser fan hydraulic system, refer to figure 18 in section 16 "Heating and Air Conditioning".

The steering wheel transmits the steering motion through the steering column, and then to the steering gearbox. The pitman arm, located on the steering gearbox, actuates the drag link which moves the transfer lever on the first axle. Afterwards, a connecting rod transmits movement to the transfer lever on the second axle.

Steering and tire wear are affected by air suspension, brakes, wheel bearings, front suspension and front end alignment. These items are covered in their respective sections of this manual.

## OPERATION

Power steering is accomplished by hydraulic pressure. Steering fluid is supplied by a vane type hydraulic pump, mounted at rear of engine, directly under the air compressor. One hydraulic fluid line is routed from the hydraulic oil tank to the pump. Fluid displaced by the pump flows through flexible lines to the power steering gearbox. A return line is connected from the steering gearbox to the oil filter, and then back to the hydraulic oil tank.

When the steering wheel is turned, the steering shaft turns the power steering gear actuating shaft. This motion, combined with hydraulic pressure supplied to the gear by the pump, provides the rotating action of the gear output shaft which is connected to the pitman arm. This hydraulic pressure is also transmitted to the steering cylinder on the second axle in order to assist the power steering gearbox.

A strainer, mounted at the hydraulic oil tank outlet, ensures that foreign matter does not enter the pump. A return line filter (10 microns) is also installed against the rear wall of the engine compartment.

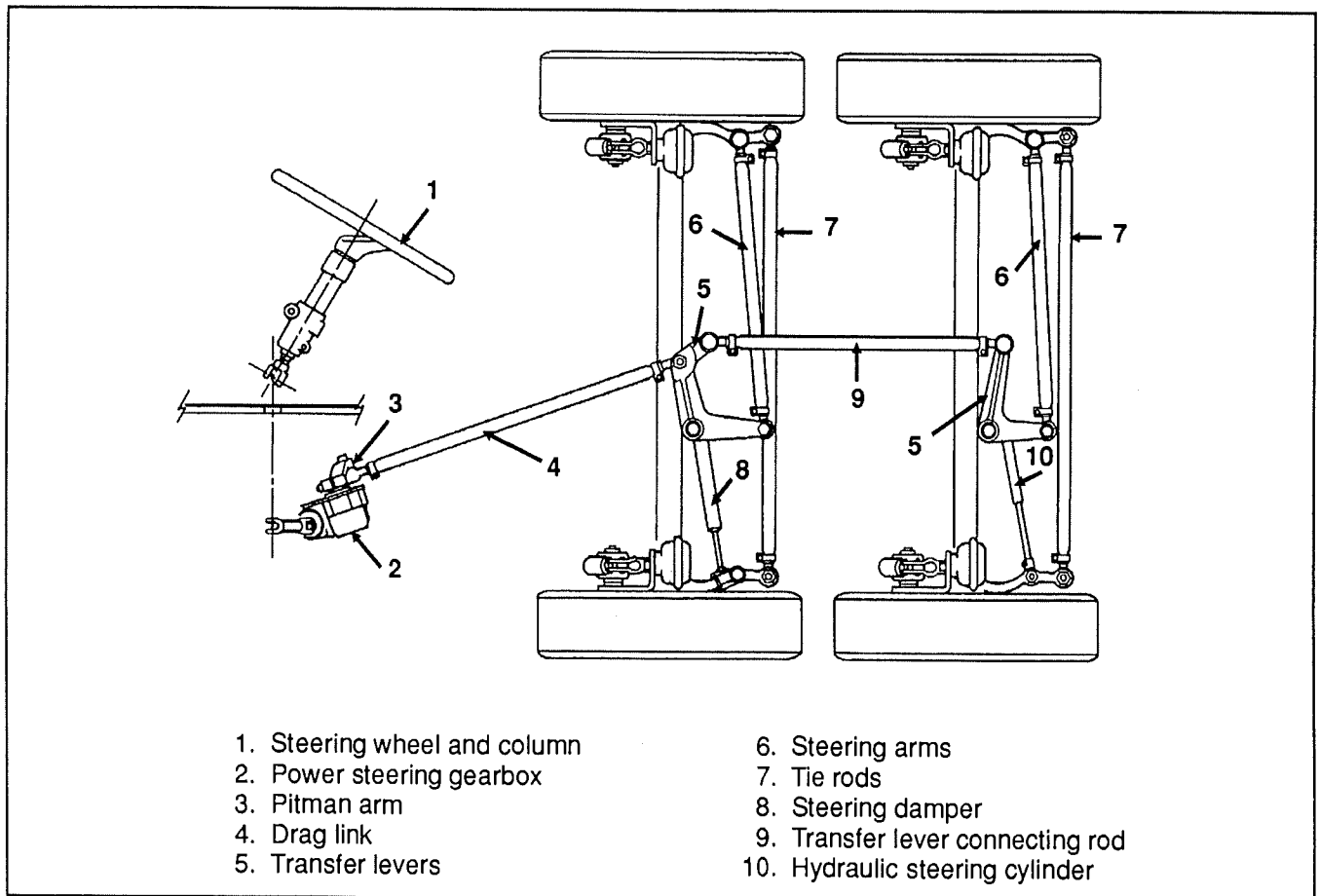

FIG. 1 - Steering system components

MAS-1201.IMG

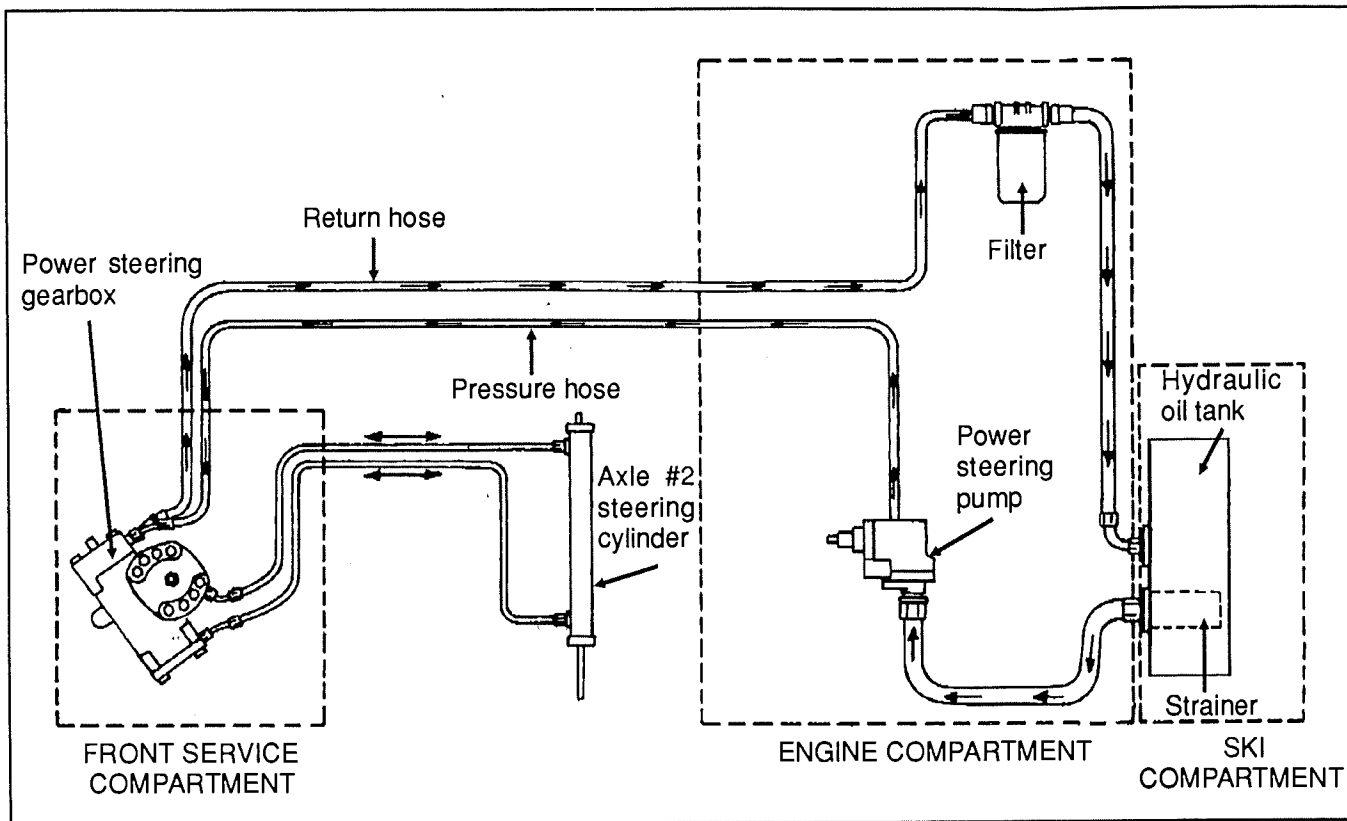

FIG. 2 - Power steering hydraulic system

MA5-1202.IMG

## MAINTENANCE

The power steering system requires little maintenance. However, the system should be kept clean to insure maximum operating performance and troublefree service. Periodic inspection should also be made to check for leaks.

At regular intervals, fluid level in the hydraulic oil tank should be checked and fluid added when required. Refer to "Hydraulic oil tank" later in this section. When the slightest evidence of dirt, sludge or water is discovered in the system, the power steering hydraulic system and condenser fan hydraulic system must be drained as follows:

1. Remove both drain plugs under hydraulic oil tank.
2. Disconnect both delivery hoses from hydraulic oil tank.
3. Disconnect hoses from steering gearbox.
4. Disconnect hoses from the solenoid control relief valve of the condenser fan hydraulic system.
5. Replace the hydraulic oil filter (Refer to "Hydraulic oil filter" later in this section).
6. Clean both hydraulic oil tank strainers (Refer to "Hydraulic oil tank strainers" later in this section).
7. Allow oil to drain completely from hoses and tank, reinstall drain plugs and hoses, then refill tank with clean oil as outlined in "Hydraulic oil tank" later in this section.

Air in the hydraulic system will cause spongy action and noisy operation. When any hose has been disconnected or when oil has been lost for any reason, the system must be bled. Bleed system as outlined under heading "Bleeding power steering hydraulic system" later in this section.

**WARNING: Do not operate the pump without fluid in the hydraulic oil tank.**

If the steering linkage between the steering gear and the four front wheels is out of adjustment, bent, twisted or worn, the steering of the coach will be seriously impaired. Whenever any steering linkage part is repaired, replaced or adjusted, steering geometry and front wheel alignment must be checked and necessary corrections made. Refer to section 07 entitled "Front Axles" for front end alignment.

At regular lubrication intervals, the steering linkage should be thoroughly inspected for worn or loose components. Refer to "Lubrication Chart and Service Check Points" in section 19.

After the vehicle has been operated continually and high mileage figures have been reached, overhaul of the various steering units will be required. General overhaul procedure normally requires removal of the entire assembly, cleaning and inspection of all parts and final assembly. Careful inspection of all parts during overhaul is very important and must not be neglected.



## POWER STEERING GEARBOX

Refer to the "HFB-70 Service Manual" annexed to this section for the complete description and the maintenance procedure of the power steering gearbox.

**ATTENTION:** Before attempting to adjust the poppet valves of the power steering gearbox, properly set the steering stop screws as outlined in section "07 Front axles (1 & 2)" under heading "Steering stop screw adjustments (Axles 1 and 2)".

## BLEEDING POWER STEERING HYDRAULIC SYSTEM

To bleed the power steering hydraulic system, refer to the "HFB-70 Service Manual" under heading "Filling and air bleeding the system" annexed to this section.

## HYDRAULIC PRESSURE TEST

Perform a pressure test as outlined in the "HFB-70 Service Manual" under heading "Troubleshooting information" annexed to this section.

## TROUBLESHOOTING

Perform troubleshooting of the steering gearbox as outlined in the "HFB-70 Service Manual" under heading "Troubleshooting guide" annexed to this section.

## TROUBLESHOOTING CHECK LIST

Refer to the form "TRW Troubleshooting check list" annexed to this section.

## POWER STEERING HYDRAULIC PUMP

### Description

The power steering pump is a vane type, hydraulic unit which supplies hydraulic pressure for the operation of the steering gear. The pump is mounted on the engine flywheel housing directly under the air compressor.

**CAUTION:** At removal of the power steering pump, inspect carefully the drive coupling (fiber component located between the engine gearing and the pump), and replace if necessary. Ensure that drive coupling is correctly positioned before reinstalling steering pump.

## Removal and installation

The pump is accessible through the engine compartment door. To remove the pump, remove the cable tie retaining the engine breather hose to the pump, disconnect the inlet and outlet hoses from the pump, then remove the two mounting bolts. Mounting flange gasket should be replaced whenever pump is removed. To install pump, reverse the removal procedure.

## Maintenance

For the maintenance of the power steering hydraulic pump, refer to the "Overhaul Manual" annexed to this section.

## HYDRAULIC OIL TANK

### Description

The hydraulic oil tank is located in the L.H. side drive axle wheelhouse. This reservoir feeds oil to the hydraulic circuits of the power steering and the condenser motor (for more details, refer to figure 18 in section 16 "Heating and Air Conditioning"). This reservoir has been specially designed with the adjunction of an inside partition and the location of the oil returns. Thus, if an oil leak should occur on the hydraulic circuit of the condenser fan motor, this section of the reservoir would empty, while the other section of the tank would not be affected. The power steering hydraulic circuit would operate normally and safely. The opposite is not applicable if a leak should occur in the power steering hydraulic system. The section of this tank will drain completely, and as soon as the solenoid control relief valve on the condenser motor is deactivated, the remaining oil in reservoir would drain gradually. The total capacity of the tank is 10 U.S. gal (38 liters) including the hoses.

## Oil checking

1. Stop engine, and open L.H. side ski compartment.
2. Remove the twist dipstick located in the L.H. side corner and wipe with a clean rag (see fig. 3).
3. Insert dipstick in tank, then remove it again to check level.
4. Bring level to the "Full" mark with SAE 5W30 engine oil for moderate weather areas, and SAE 10W30 engine oil for other areas.
5. Replace and screw the twist dipstick.

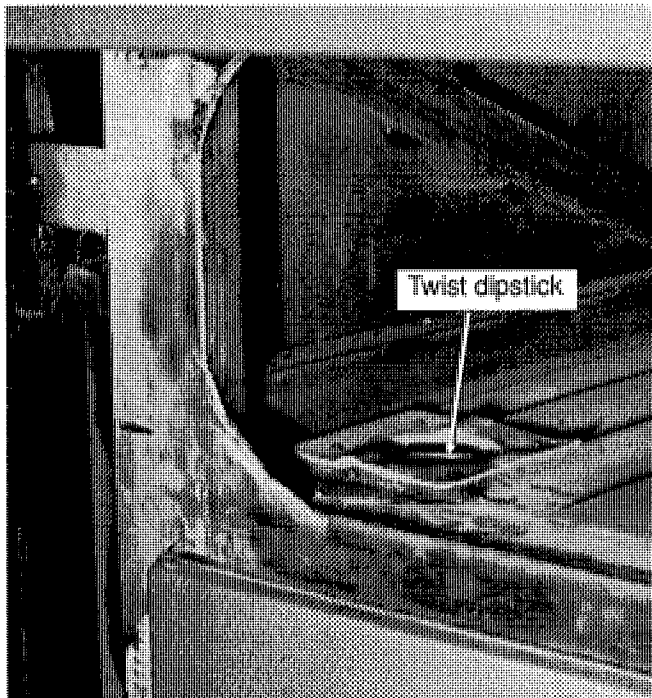

FIG. 3 - Hydraulic oil tank

OPFIG41.IMG

## HYDRAULIC OIL TANK STRAINERS

### Description

The hydraulic oil tank is provided with two identical strainers (25 microns) without a bypass, which are located at the bottom of the tank and accessible by the engine compartment. The strainer located near the radiator, filters oil before it flows to the hydraulic pump (for the condenser motor), while the other filters the power steering pump oil.

### Maintenance

Cleaning of the strainers is required only in case of an important failure of the hydraulic system components, or when the slightest evidence of dirt, sludge or water is discovered in the system. Proceed as follows to clean strainers:

1. Drain the hydraulic oil tank by removing both drain plugs located under the tank and accessible by the wheelhouse.
2. Disconnect the delivery hose from tank.
3. Remove the six (6) bolts retaining the flange to the hydraulic oil tank adaptor (see fig. 4).
4. Unscrew the strainer from flange.
5. Clean strainer by washing thoroughly in a suitable solvent, blowing air from the inside towards the outside.
6. Reinstall by reversing the above procedure. Use a new gasket.
7. Repeat the above procedure for the other strainer.
8. Wrap threads of drain plugs with teflon tape, then screw plug in place.
9. Fill hydraulic oil tank. (Refer to previous heading "Hydraulic oil tank").

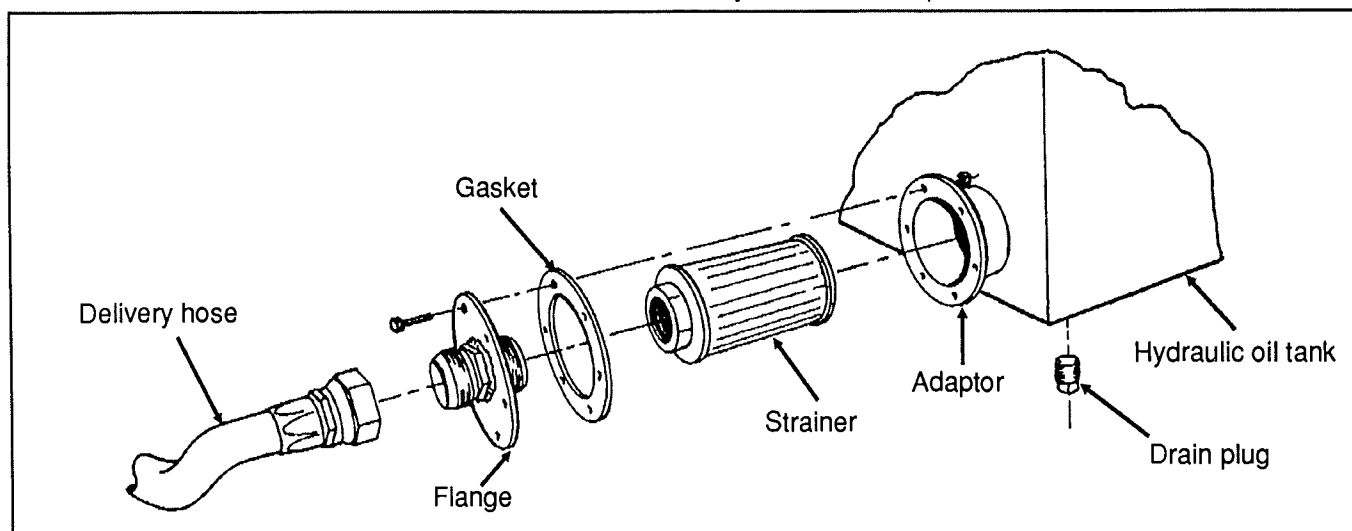

FIG. 4

MA5-1204.IMG

## HYDRAULIC OIL FILTER

### Description

The spin-on type filter used in the power steering and condenser fan motor hydraulic circuits is mounted on the return line of these two components in the engine compartment. To gain access, open the third R.H. side baggage compartment door and raise the engine access panel; the filter is located on the left side near the rear wall.

### Replacement

Replace filter at 50 000 mile (80 000 km) intervals according to the following procedure:

1. Stop engine.
2. Unscrew the filter and discard it.
3. Clean the filter base surface.
4. Apply clean oil on gasket of new filter.
5. Tighten filter 7/8 to 1 turn after gasket contacts base.
6. Check for leaks.

## STEERING WHEEL

### Removal

1. Set the battery main disconnect switches to the "Off" position.
2. Using a tool, such as a little flat head screwdriver, pry away the electric horn cap.
3. Loosen the small screw in center of cap and the one retaining the black wire, then disconnect the white terminal. Remove horn cap.
4. Loosen and remove the steering wheel nut and washer.
5. Using a suitable puller, remove the steering wheel.

### Installation

To install, reverse the removal procedure then torque steering wheel nut to 35 - 45 lbs.ft (47 - 60 N.m).

## STEERING COLUMN

To disassemble the steering column, refer to figure 5 as a guide. The steering column has 3 points of lubrication:

### 1. Lower steering column U-joint

This U-Joint must be lubricated every 5000 miles (8000 km) with molybdenum disulphide grease. The grease fitting is accessible through the front service compartment.

### 2. Upper steering column U-joint

This U-Joint must be lubricated every 5000 miles (8000 km) with molybdenum disulphide grease. To gain access to the grease fitting, proceed as follows:

- a. From the driver's compartment, unfasten and lift the steering column boot, then remove the four (4) snap caps on front of upper steering column cover.
- b. Unscrew the four (4) retaining screws on upper steering column cover, then remove cover.
- c. Unscrew the three (3) retaining screws on lower steering column cover, then remove cover.
- d. Position the steering wheel in order to gain access to the U-joint grease fitting.

### 3. Lower steering column slip joint

The slip joint must be lubricated once a year with molybdenum disulphide grease. To lubricate the slip joint, proceed as follows:

- a. Remove the upper and lower steering column covers as outlined previously.
- b. Pull down the handle located on the left hand side of the steering column, lift steering wheel to its maximum position, then push handle up to lock the steering mechanism in this position.
- c. Remove the "Allen" screw (see fig. 5). Install a grease fitting and lubricate as required.
- d. Remove the grease fitting, then reinstall the "Allen" screw.

**WARNING: Do not forget to remove grease fitting immediately after lubrication, as it will interfere with floor and could cause sudden loss of vehicle control.**

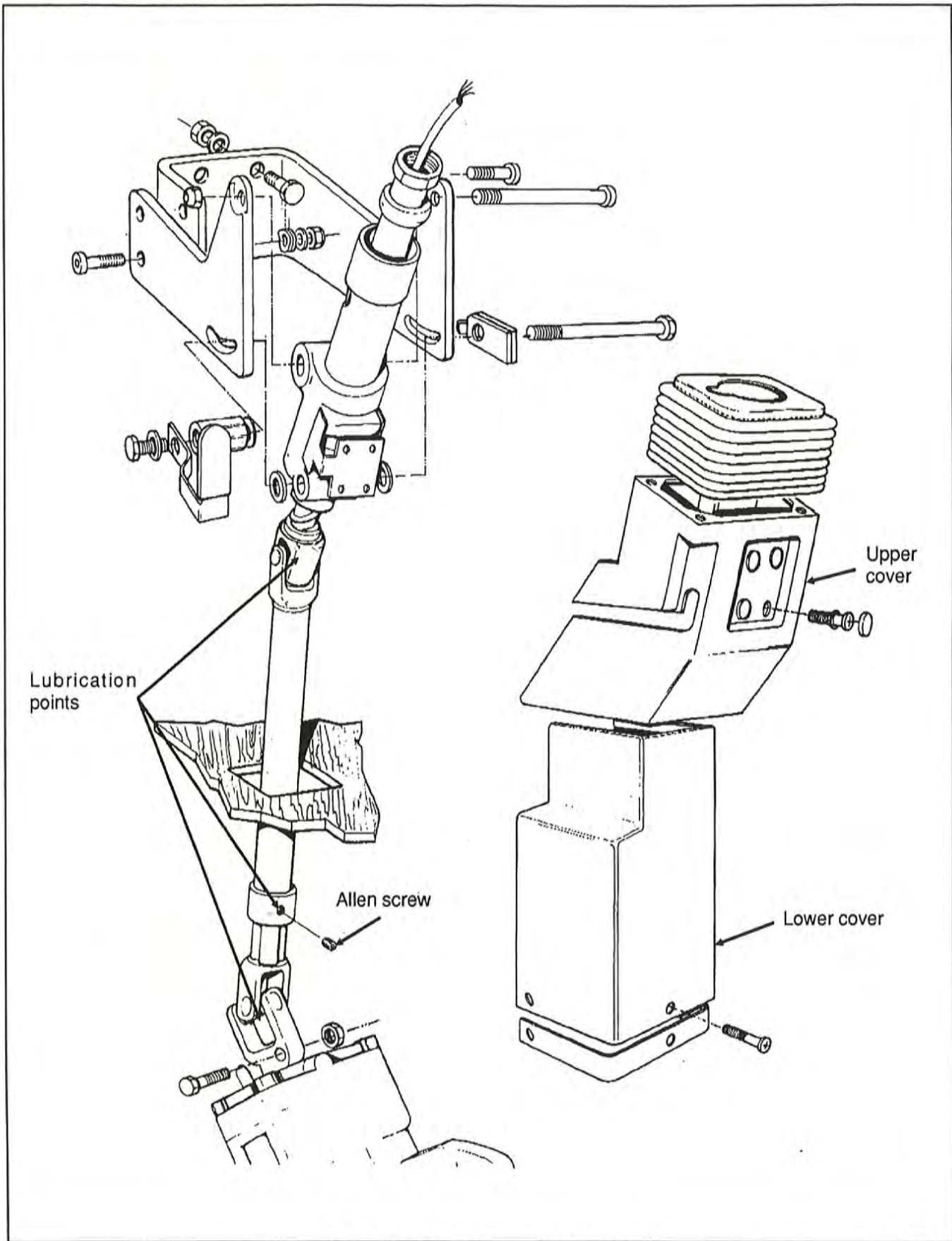

FIG. 5 - Steering column disassembled

MA5-1205.IMG

## TURNING ANGLE ADJUSTMENT

To adjust the turning angle, refer to section "07 Front Axles (1 & 2)" under heading "Steering stop screw adjustments (Axles 1 and 2)".

## STEERING LINKAGE ADJUSTMENT

To adjust the steering linkage, refer to section "07 Front Axles (1 & 2)" under heading "Front end alignment".

## PITMAN ARM

To properly adjust the pitman arm on the sector shaft of the steering gearbox, refer to section "07 Front Axles (1 & 2)" under heading "Pitman arm".

## REAR AXLE STEERING CONTROL

As the rear axle steering is not controlled by the power steering system, but by means of a linkage connected to the central joint (articulation), refer to section 09 "Rear Axle" under heading "Rear end alignment" for further details on the steering of this axle.

## POWER STEERING CYLINDER

### Description

The power steering cylinder acts as an auxiliary power source to assist the mechanical steering. Flexible hoses carry hydraulic fluid to the power steering cylinder to actuate the cylinder piston for right and left turns. When the steering wheel is turned, the control valve on the steering gear housing, directs hydraulic fluid under pressure from the hydraulic pump to either side (depending on whether a right or left turn is being made) of the power cylinder piston. This produces movement of the piston and its related steering linkage.

When turn is completed, reduced effort in the steering wheel allows steering geometry of the vehicle to return wheel to a neutral or straight-ahead position. When returning to a neutral position, oil on one side of the cylinder piston is forced back to the hydraulic oil tank by oil on other side of the piston, thus equalizing the oil pressure. This constant amount of oil in the cylinder acts as a shock absorber or cushion against road shocks.

## Removal and installation

1. Clean area around hose connections on power steering cylinder.
2. Disconnect the two hydraulic hoses from the power steering cylinder and drain fluid into a container. Do not reuse this fluid. Cover hose fittings and ports in cylinder. Tag hoses to ease reinstallation.
3. Remove cotter pin, nut and washer securing cylinder end to the tie rod arm, discard cotter pin, then separate the cylinder end from the tie rod arm using a fork-type separator.
4. Remove cotter pin, nut and washer securing cylinder end to the axle bracket, discard the cotter pin, separate the cylinder end from the axle bracket using a fork-type separator, then remove the cylinder from its location.
5. Reinstall the power steering cylinder by reversing the above procedure. Recommended torque for cylinder ends is 160 - 215 lbs.ft (218 - 290 N.m). Always replace cotter pins with new ones. Apply teflon pipe sealant on hose fitting threads.

## STEERING DAMPER

This vehicle is provided with a steering damper cylinder installed on left hand side of axle #1. The cylinder is non-repairable, so if oil leakage is evident or cylinder has no resistance, the complete unit must be replaced. Lubricate the steering damper cylinder end every 5000 miles (8000 km) with molybdenum disulphide grease.

## LUBRICATION

All lubrication fittings must be clean before applying lubricant. Also, always be sure equipment used in applying lubricant is clean. Every precaution should be taken to prevent entry of dirt, grit, lint or other foreign matter into lubricant containers. Replace fittings that have become broken or damaged. Lubrication intervals, as well as the recommended lubricants for the steering components, are given in section 19 of this manual in the "Lubrication Chart and Service Check Points". The intervals given in the chart are recommended for normal service. More frequent intervals may be required under severe operating conditions.

**SPECIFICATIONS****POWER STEERING GEARBOX**

Make . . . . . Ross gear  
Model . . . . . HFB70029  
Ratio . . . . . 23.3:1  
Prévost number . . . . . 66-0785

**POWER STEERING PUMP**

Make . . . . . Vickers  
Model . . . . . VTM-42-50-55-15-ME-RI-14S4.  
Type . . . . . Vane  
Maximum output pressure . . . . . 1500 psi (10 342 kPa)  
Maximum delivery . . . . . 5.5 gal/min. (25 l/min.)  
Prévost number . . . . . 66-0767

**HYDRAULIC OIL TANK**

Make . . . . . Prévost  
Oil capacity . . . . . 6.5 U.S. gal (24,6 l)  
Prévost number . . . . . 16-0670

**HYDRAULIC OIL STRAINERS**

Make . . . . . Vickers  
Model . . . . . 0F3-10-10  
Type . . . . . Cleanable  
Filter size . . . . . 25 microns  
Rated . . . . . 20 U.S. gal/min (75,8 l/min)  
Supplier number . . . . . 215240  
Prévost number . . . . . 66-0769

**HYDRAULIC OIL FILTER**

Make . . . . . Vickers  
Type . . . . . Disposable cartridge  
Filter size . . . . . 10 microns  
Supplier number . . . . . 573082  
Prévost number . . . . . 66-0671

**POWER STEERING CYLINDER**

Make . . . . . Lessard  
 Model . . . . . L-5 Special  
 Bore . . . . . 1.5" (38,1 mm)  
 Stroke . . . . . 15" (38,10 cm)  
 Rod diameter . . . . . .875" (22,23 mm)  
 Collapsed length . . . . . 24.125" (61,28 cm)  
 Supplier number . . . . . 006-8816-0  
 Prévost number . . . . . 16-0689

**STEERING DAMPER CYLINDER**

Make . . . . . Gabriel  
 Extended length . . . . . .32.73" (83,13 cm)  
 Collapsed length . . . . . .20.26" (51,46 cm)  
 Stroke . . . . . .12.47" (31,67 cm)  
 Supplier number . . . . . 651535  
 Prévost number . . . . . 66-0885

**STEERING DAMPER CYLINDER ROD END**

Make . . . . . Aurora  
 Supplier number . . . . . AW 12Z  
 Prévost number . . . . . 66-0884







# ARTICULATION

## CONTENTS OF THIS SECTION

DESCRIPTION . . . . .	13-1
LUBRICATION . . . . .	13-1
ARTICULATION DAMPERS . . . . .	13-2
MULTI-DISC BRAKE REMOVAL . . . . .	13-2
MULTI-DISC BRAKE INSPECTION . . . . .	13-4
MULTI-DISC BRAKE INSTALLATION . . . . .	13-6
ALIGNMENT OF FRONT SECTION IN RELATION WITH REAR SECTION . . . . .	13-6
REAR AXLE STEERING CONTROL . . . . .	13-7
SPECIFICATIONS . . . . .	13-8

*[Faint, illegible text, possibly bleed-through from the reverse side of the page]*

## DESCRIPTION

This vehicle is provided with an articulation section located at 60% of the vehicle length. The articulation turntable actuates the rear steering axle. A combination of both components ensures a turning radius which is less than for a conventional vehicle.

The articulation section consists in a turntable, a multi-disc brake, dampers, articulation safety system controls and rear section pivot pins. As the articulation is integrated to the structure, it permits vertical and horizontal axis control freedom, while limiting motion of one section in relation to the other. This working efficiency, along with other controls in the articulation section, enable the vehicle to achieve a formidable stability at cruising speed.

Here are in few words, the specific functional aspects of features provided in the articulation section.

A) A turntable, which steers the rear axle wheels through a divider pivoting arm, rods and a drag link pivot.

B) A multi-disc brake centrally located at the articulation level, acts as a controlled braking force against rear section movements as well as an anti-jackknife device. It is important to note that pressure on the multi-disc brake will be applied only when these situations occur.

1. It is activated with **full pressure** when actuating service brakes.
2. It is activated with **full pressure** when driving faster than 40 miles per hour (65 km/h).
3. It is activated with **full pressure** when driver actuates the anti-jackknife switch on the L.H. side control panel (see "*Operator's Manual*" for more details).

C) Two heavy-duty dampers increase steadiness of the rear section, thus preventing lateral movement of the latter.

D) A safety system which advise the driver of rear section position in relation with front section of vehicle. Refer to heading "*Articulation safety system*" in section "*Safety*" of the "*Operator's Manual*" for more details.

E) Two rear section pivots attached to the turntable which link the rear section to the front one.

## LUBRICATION

The articulation mechanism should be lubricated every 7,000 to 20,000 mile (10 000 to 30 000 km) interval, according to operating conditions, or every three months, whichever occurs first. This part of the maintenance is carried out by means of a grease manifold, located on the L.H. side of the articulation frame. The grease manifold is accessible through an access panel located in the first L.H. side baggage compartment of rear section. Refer to figure 1 for details.

Major lubrication points are connected to this grease manifold; another grease fitting for the central joint lever bearing, which is accessible from inside the vehicle under the front turntable, should be lubricated separately as an individual service point. Finally, the contact surfaces of the turntable should be greased manually, in order to prevent a noisy articulation. All other articulation components and linkages are prelubricated and require no further lubrication. For recommended lubricant and frequency, refer to the "*Lubrication chart and service check points*" annexed to section 19 "*Lubrication*".

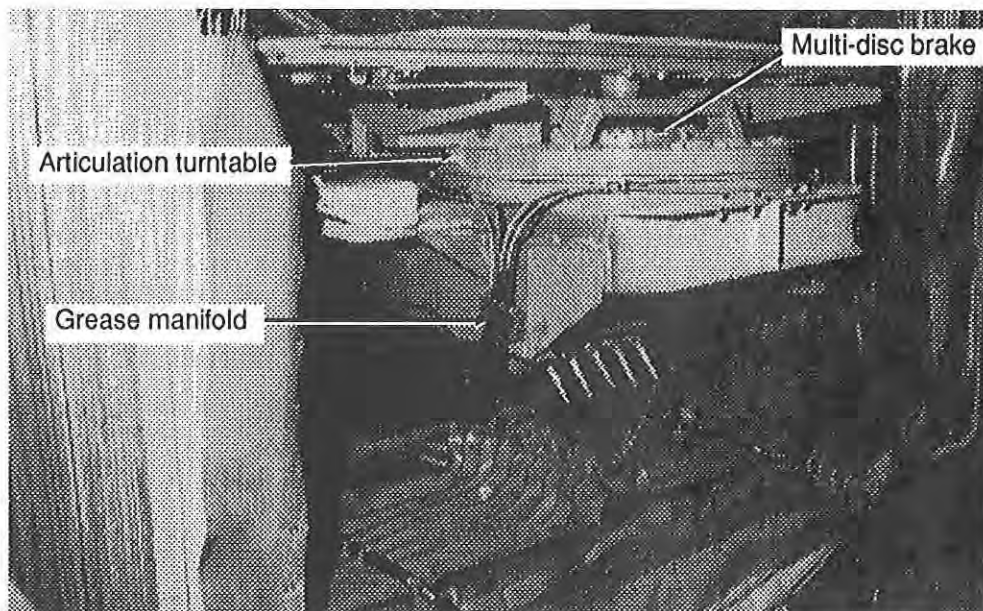

FIG. 1 - Articulation view

MAS-1301.IMG

## ARTICULATION DAMPERS

### Description

Two heavy-duty articulation dampers ensure steadiness of the rear section, thus preventing lateral movement of the latter. Inspect dampers periodically for leaks. Leaking units should be replaced. Extremities of these dampers are provided with a grease fitting connected to the grease manifold. These are automatically lubricated when proceeding to the articulation lubricating procedure.

### Removal and replacement

1. Open the first L.H. side baggage compartment of rear section, then remove the articulation access panel.
2. Locate articulation dampers (below articulation multi-disc brake). Disconnect the grease fitting hose routed from the grease manifold to the damper extremities.

**NOTE:** Identify hoses to ease reassembly procedure.

**NOTE:** Position the grease lines so they will not be damaged when removing dampers.

3. On each extremity, remove cotter pins, then unscrew the retaining nuts.
4. Remove articulation dampers.
5. Install new articulation dampers with tag facing rear section and red point facing the ground. Refer to figure 2 for details. Place washers and nuts, then tighten securely.

**CAUTION:** Ensure the dampers are correctly installed in the right direction, as it may alter damper operation.

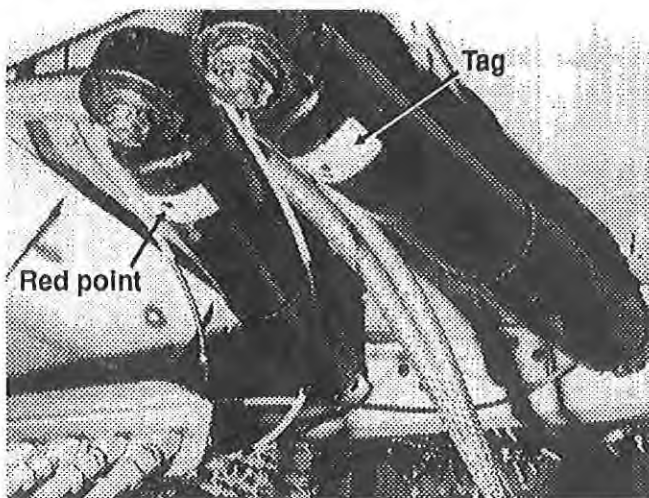

FIG. 2 - Articulation damper installation

6. Reconnect grease lines to their corresponding damper extremities.
7. Use a grease gun at grease manifold to lubricate damper extremities.

## MULTI-DISC BRAKE REMOVAL

1. From inside the vehicle, open the halves of turntable discs and locate the connection tube of the air line as well as the grease lines of the central lubrication on the multi-disc brake.
2. At the rear half of turntable, disconnect the air line at the multi-disc brake, then remove the fitting from the multi-disc brake cover. Refer to figure 3 for details.

**CAUTION:** This fitting must be removed to provide additional space when removing the multi-disc brake. Fitting can be damaged if it remains on the multi-disc brake cover.

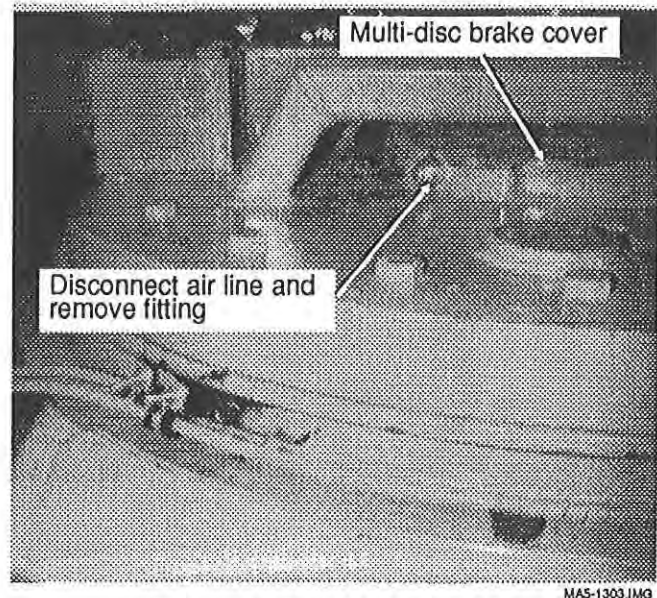
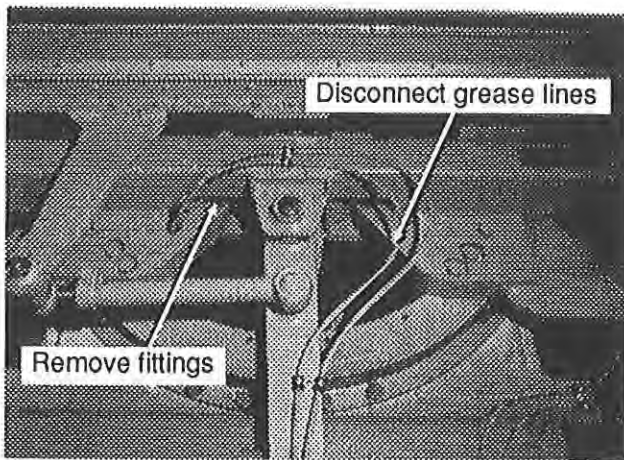

FIG. 3 - Rear half of turntable

3. At the front half of turntable, disconnect the lubrication lines (2 grease connections on the multi-disc cover). Refer to figure 4. Remove the fittings afterward to provide additional space when removing multi-disc brake.
4. Open the first L.H. compartment of rear section, then open the articulation access panel. Place safety protecting truss, as a plywood panel, on bottom of articulation during removal of multi-disc brake.

**CAUTION:** This operation is important in order to protect articulation bellows. Never attempt to walk on the pleated material without having previously taken the appropriate precautions.



MA5-1304.IMG

FIG. 4 - Front half of turntable

**WARNING:** Before beginning work in the articulation area, ensure that all preventive measures have been taken, such as setting the remote control switch in engine compartment to the "OFF" position, in order to prevent accidental moving of vehicle.

5. Remove the articulation dampers as described under previous heading "Articulation damper removal and replacement" in this section.

6. Remove the bolt retaining rear of multi-disc brake arm to the frame (see figure 5).

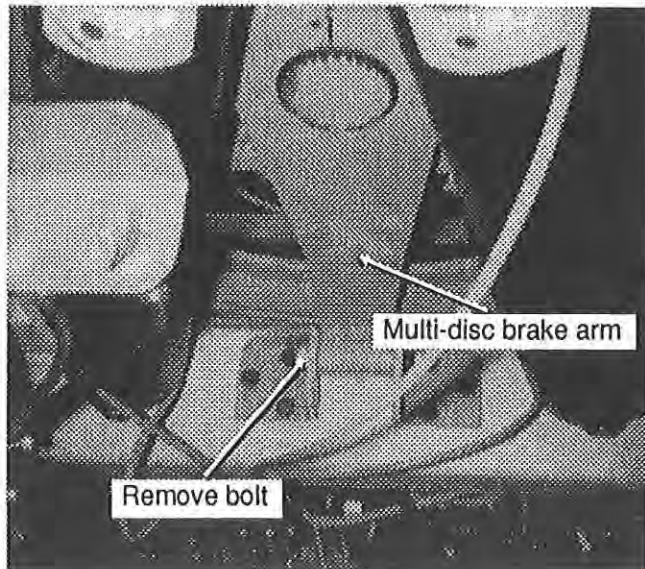

MA5-1305.IMG

FIG. 5

7. Support securely the multi-disc brake, then loosen and remove the wire protection of both rear retaining screws.

**WARNING:** Additional assistance may be required to remove multi-disc brake, in order to prevent personal injury.

8. Remove the multi-disc brake from the mounting by unscrewing the two (2) retaining screws and two (2) securing nuts.

## MULTI-DISC BRAKE INSPECTION

### Disassembly

1. After removal of the multi-disc brake, put the device with lever below, on a clean working surface (see figure 6).
2. Remove the 8 retaining bolts, 2 screws and 2 dowels. Refer to figure 7 for details.
3. Remove the cover carefully and check that linings are not spoiled by grease from the bearings.
4. Check that the O-rings are clean, lightly greased, and located correctly in the grooves, then push the piston back into the cover carefully.
5. Remove linings and steel discs from the multi-disc brake body and put them on a clean cloth.
6. Remove dust from multi-disc brake body, steel discs, linings and grooves by vacuum cleaning.

7. Check steel discs and linings. If the linings are contaminated by grease, or if their surfaces are glazed, they have to be replaced completely.

8. Clean bearings and check the whole multi-disc brake for wear or damage; replace parts if necessary.

### Reassembly

1. When all parts are serviceable, grease the bearings slightly.
2. Reinstall linings and steel discs in the opposite order.
3. Grease and reinstall O-rings.
4. Replace the cover and piston; make sure that it is in the correct position. Replace the 2 screws, 2 dowels, and 8 retaining bolts and washers. Torque the 8 retaining bolts to 80 ft.lbs (110 N.m).

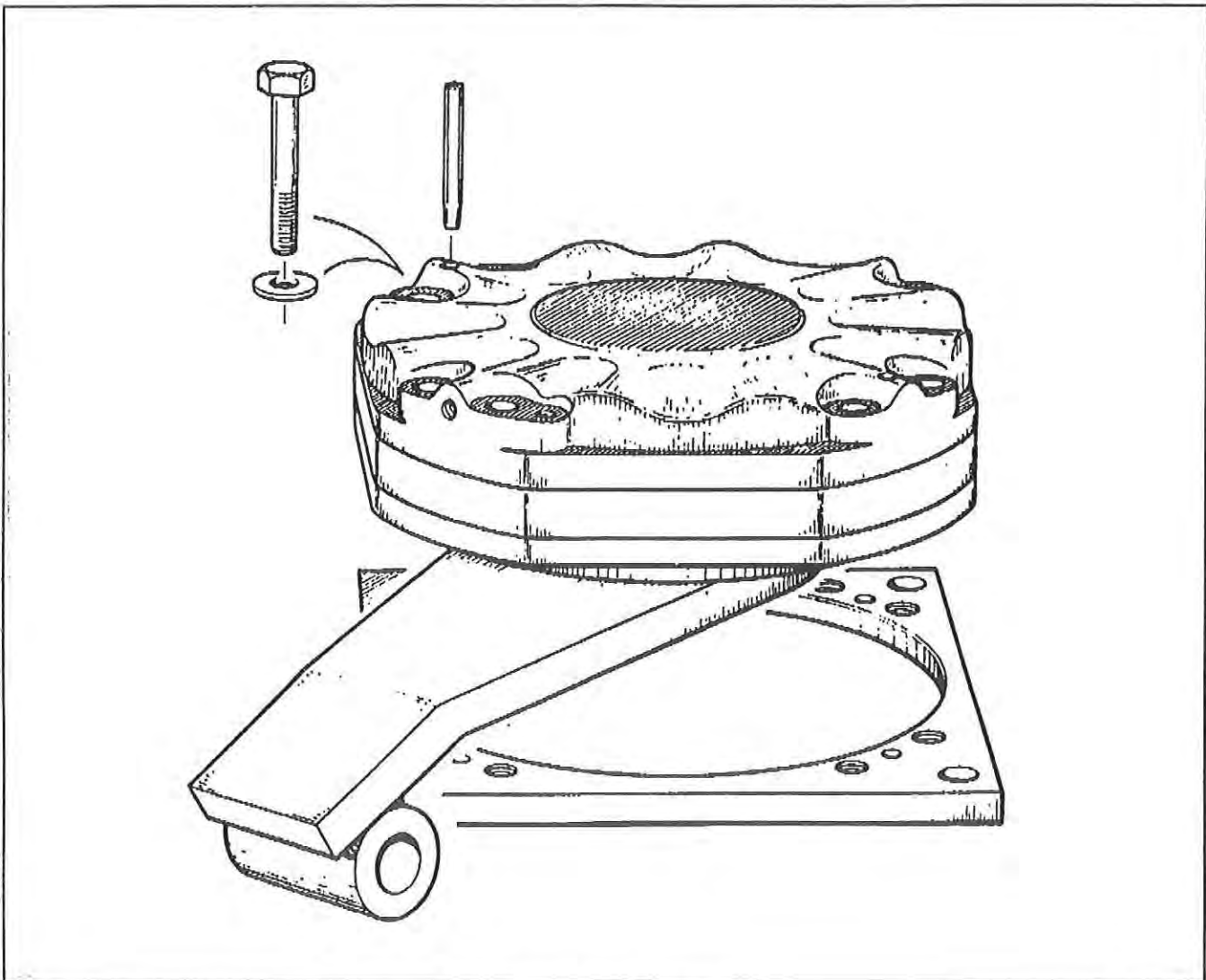
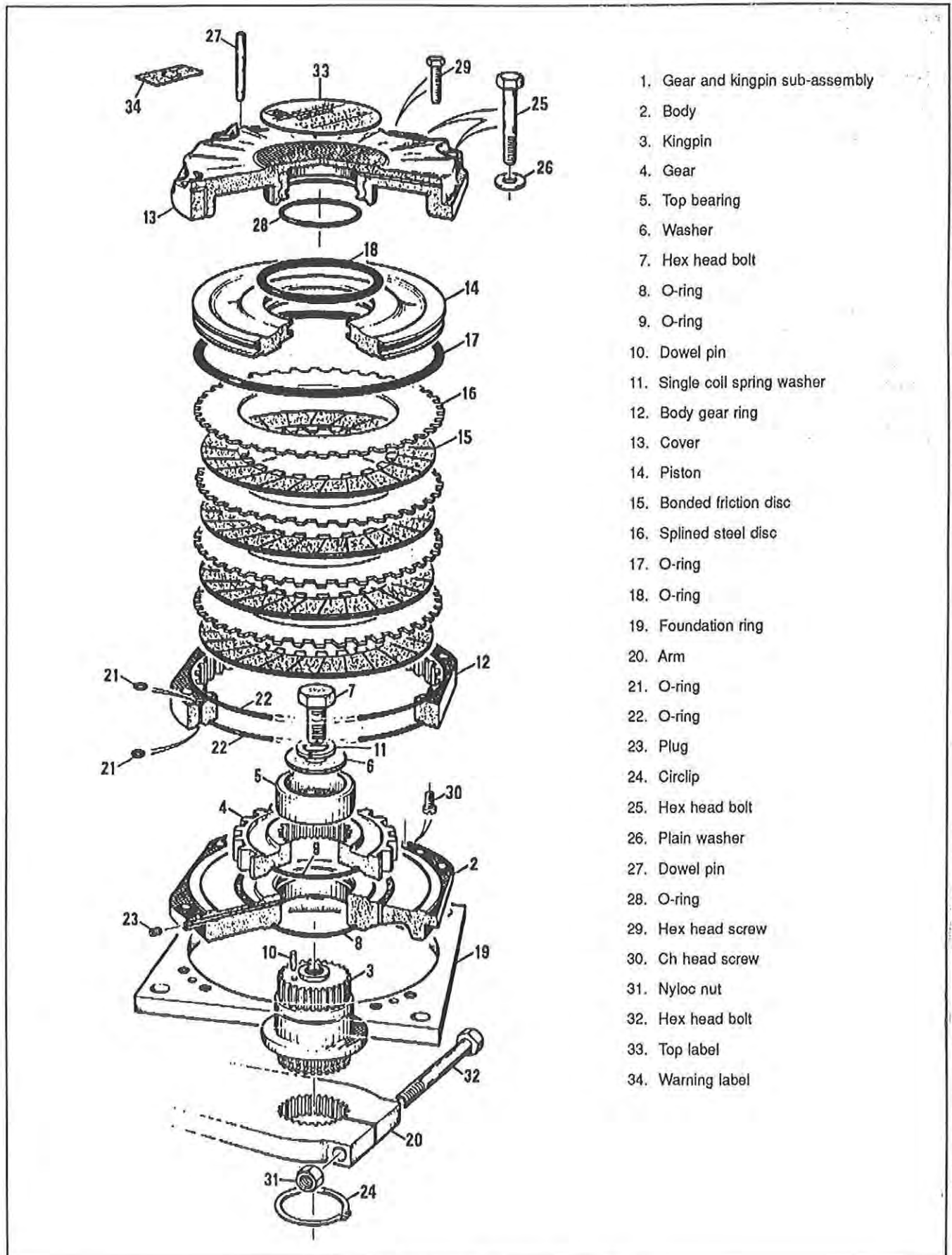

FIG. 6 - Multi-disc brake with lever

MA5-1306.IMG



1. Gear and kingpin sub-assembly
2. Body
3. Kingpin
4. Gear
5. Top bearing
6. Washer
7. Hex head bolt
8. O-ring
9. O-ring
10. Dowel pin
11. Single coil spring washer
12. Body gear ring
13. Cover
14. Piston
15. Bonded friction disc
16. Splined steel disc
17. O-ring
18. O-ring
19. Foundation ring
20. Arm
21. O-ring
22. O-ring
23. Plug
24. Circlip
25. Hex head bolt
26. Plain washer
27. Dowel pin
28. O-ring
29. Hex head screw
30. Ch head screw
31. Nyloc nut
32. Hex head bolt
33. Top label
34. Warning label

FIG. 7 - Disassembly of multi-disc brake

MA5-1307.IMG



## MULTI-DISC BRAKE INSTALLATION

1. Reinstall the multi-disc into the mounting from below. Replace the two (2) retaining bolts at rear, and nuts at front, then torque to 300 ft.lbs (410 N.m).

**WARNING: Additional assistance is required when reinstalling multi-disc brake, in order to prevent personal injury.**

2. Install a new wire protection at both rear retaining bolts at the same time. Reconnect and secure the multi-disc brake arm with the retaining bolt.

3. Replace the articulation dampers according to the procedure given under previous heading "*Articulation damper removal and replacement*".

3. From inside the vehicle, raise the rear half of turntable and reinstall the air line fitting on the multi-disc cover, then connect the air line to this fitting.

4. Raise the front half of turntable, and reinstall the grease line connection fittings. Reconnect the grease lines to the fittings. When grease lines are reinstalled, lower the halves of turntable discs.

5. Lubricate the multi-disc brake by means of the grease manifold on the L.H. side of articulation frame. Overflow grease will be expelled by the relief hole in the cover for the top bearing, and by another relief hole on the underside of the body near the kingpin for the bottom bearing.

6. Remove the safety truss, replace the access panel and close the baggage compartment door.

## ALIGNMENT OF FRONT SECTION IN RELATION WITH REAR SECTION

### Description

On the articulated vehicle, there is some particularities to respect when proceeding with this alignment procedure. In addition to toe-in and drive axles to frame alignment, you must proceed with the alignment of rear section in relation with the front one. This procedure is very important and must be done before proceeding with rear axle (5) alignment procedure.

Proceed as follows to align rear section in relation with front section.

1. Using the jacking points on the body (refer to section 17 "*Body*" under heading "*Vehicle jacking points*"), raise vehicle sufficiently so that wheels do not touch the ground.

2. Place heavy-duty portable turntables under rear axle (axle 5) wheels, then lower the vehicle on plates (see figure 8).



FIG. 8 - Turntable Installation

MA5-1308.IMG

3. Attach a string along the vehicle body (R.H. or L.H. side). At rear of vehicle, loosen one screw of the flasher, then loop string around the screw. Retighten screw.

4. Place tape on hip of the rear corner to protect the paint. Install a 1" spacer at the extremity of straight line body (refer to figure 9 for details).

5. At front of vehicle, attach the string to the wiper arm at the same height than at rear, then install a 1" spacer rearward of the front door or driver's window, according to the side where the procedure is done.

6. Using another 1" spacer, measure each side of the accordion bellows (front and rear). The distance between string and body should be equal to 1" on each side. If this distance is not equal, slide the rear section on the turntables until the proper distance on each side is achieved.

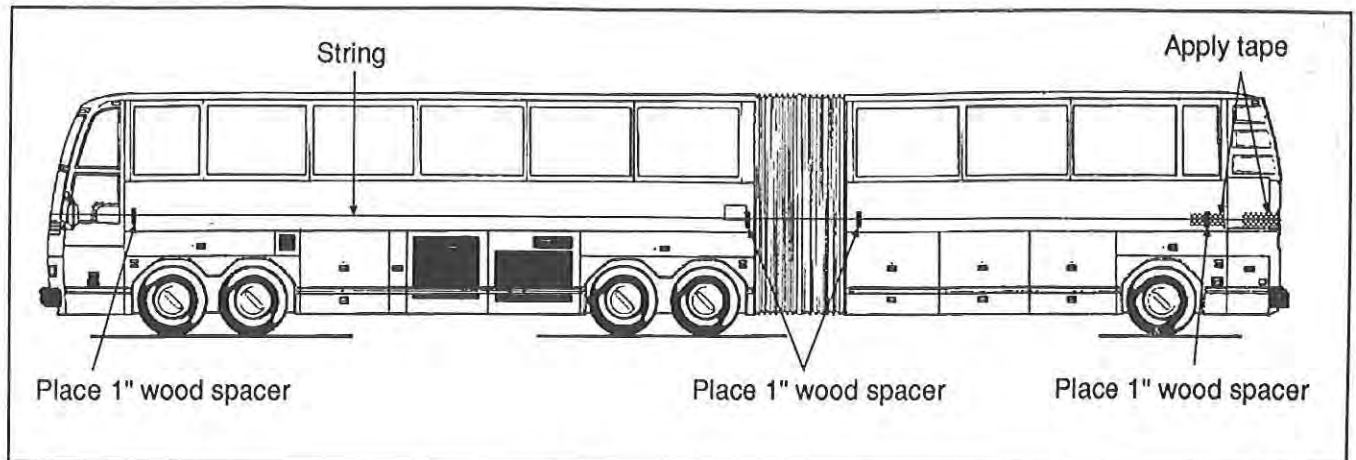

FIG. 9 - String Installation

BUSH5608.IM3

## REAR AXLE STEERING CONTROL

### Description

The rear axle, like the front axles, is a steering axle. The rear section axle is connected to the articulation turntable by means of a drag link pivot, rods and a divider pivoting arm (refer to figure 10 for details). When the front section turns, the articulation will reach an angle and the rear axle wheels are actuated by the articulation turntable motion transmitted through the rods.

### Maintenance

The divider pivoting arm and rods connected to the articulation, as well as those located between the articulation and the rear axle require no lubrication, with the exception of the central joint lever bearing and drag link pivot (see items #36 & #37 on the "Lubrication chart and service check points" annexed to section 19 "Lubrication". The central joint lever bearing is accessible by the front half of turntable inside the vehicle.

Regular maintenance of rods and pivoting arm consists mainly in a periodic inspection to check that all rod nuts are tight, that cotter pins are securely in place, and that no damage has taken place. Attention should also be given to the condition of the rod ends. In case of excessive looseness, replace the loose rod ends.

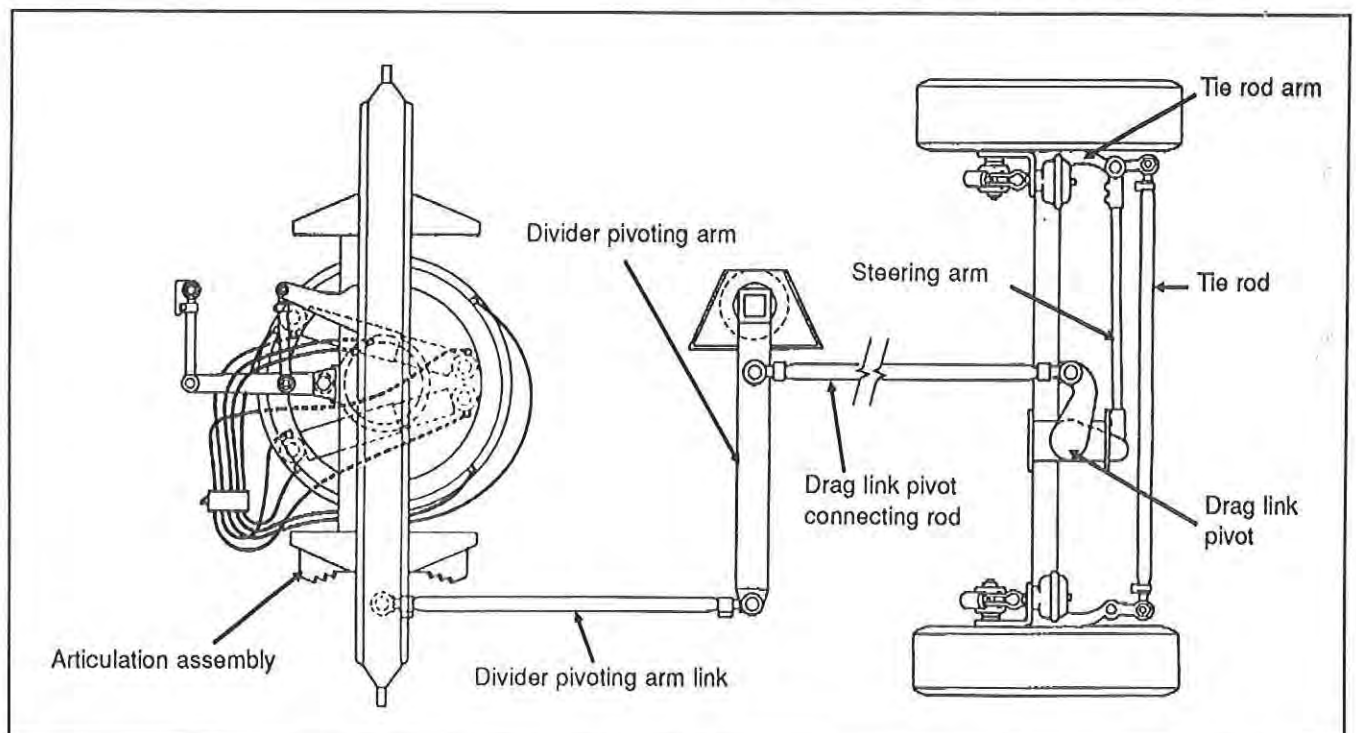

FIG. 10

MAS-0902.IM3

## SPECIFICATIONS

### MULTI-DISC BRAKE

Make . . . . . Hymer-Leichtmetallbau  
Prévost number . . . . . 66-0795  
Prévost number:  
Set of 4 splined steel discs . . . . . 64-1162  
Set of 4 bonded friction discs . . . . . 64-1161

### DAMPER

Make . . . . . Hymer-Leichtmetallbau  
Prévost number . . . . . 66-0798

### GREASE MANIFOLD

Make . . . . . Hymer-Leichtmetallbau  
Prévost number . . . . . 66-0813

# 14

# SUSPENSION

---

## CONTENTS OF THIS SECTION

DESCRIPTION . . . . .	14-1
AIR SPRING MAINTENANCE . . . . .	14-4
SHOCK ABSORBER MAINTENANCE . . . . .	14-7
RADIUS ROD MAINTENANCE . . . . .	14-8
SWAY BAR MAINTENANCE . . . . .	14-10
SUSPENSION AIR SYSTEM MAINTENANCE . . . . .	14-10
SUSPENSION HEIGHT ADJUSTMENT . . . . .	14-11
HEIGHT CONTROL VALVE OPERATION . . . . .	14-12
KNEELING/HI-BUOY SYSTEM . . . . .	14-14
SUSPENSION TROUBLESHOOTING . . . . .	14-14
SPECIFICATIONS . . . . .	14-16
TORQUE SPECIFICATIONS . . . . .	14-18



# 14 SUSPENSION

## DESCRIPTION

The vehicle is provided with an air suspension system. The system consists of air springs, height control valves, radius rods, sway bars and shock absorbers. The system operation is fully automatic and maintains a constant vehicle height regardless of load, or load distribution. The air springs are of the "rolling lobe" type and made from a special compound rubber molded to the proper contour and dimensions. The entire vertical load of the vehicle is supported by these springs. Each of the five axles is provided with identical air springs, which are attached to the subframe and to the axles. The other suspension components, with the exception of the shock absorbers and the upper retainers, are identical on axles 1, 2 and 5.

Radius rods are used to secure the axles in the proper transverse and longitudinal position. Ten (10) radius rods are provided on the front axle suspension (five per axle: four longitudinal and one transversal), eight (8) on the drive axle suspension (four per axles: two longitudinal and two diagonal) and five on the rear axle suspension with a layout identical to the front axle. Refer to figure 2, 3 and 4 for details. These rods transmit both braking and driving forces from the axles to the vehicle body.

Double-action, telescoping type shock absorbers ensure a smooth ride and enhance vehicle stability on the road. Each axle is provided with two shock absorbers with eye type mountings. Yet, axles 1 and 2 are provided with softer shock absorbers (refer to heading "Shock absorber installation" for more details, later in this section).

Sway bars are provided on each axle to control lateral motion, thus increasing vehicle stability.

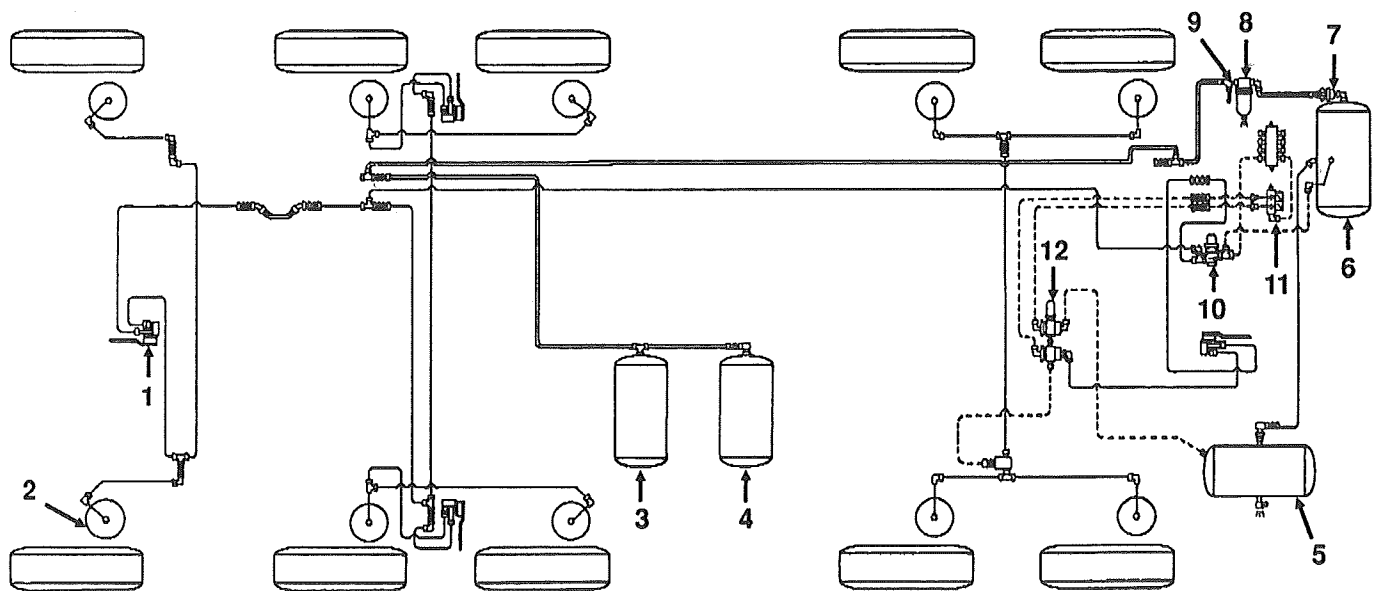

## LEGEND

- |                          |  |
|--------------------------|--|
| 1. Height control valve  | 7. Pressure protection valve (PR-4)          |
| 2. Air spring            | 8. Accessories air filter                    |
| 3. Wet tank              | 9. Accessories air tank fill valve           |
| 4. Primary tank          | 10. Pressure protection valve (PR-4)         |
| 5. Kneeling/Hi-buoy tank | 11. Bellows & exhaust control solenoid valve |
| 6. Accessories tank      | 12. Poppet valve                             |

- Kneeling circuit = Black tubing  
——— Suspension circuit = Blue tubing  
——— Supply circuit = Green tubing

FIG. 1 - Suspension component locations

MA5-1401.IMG

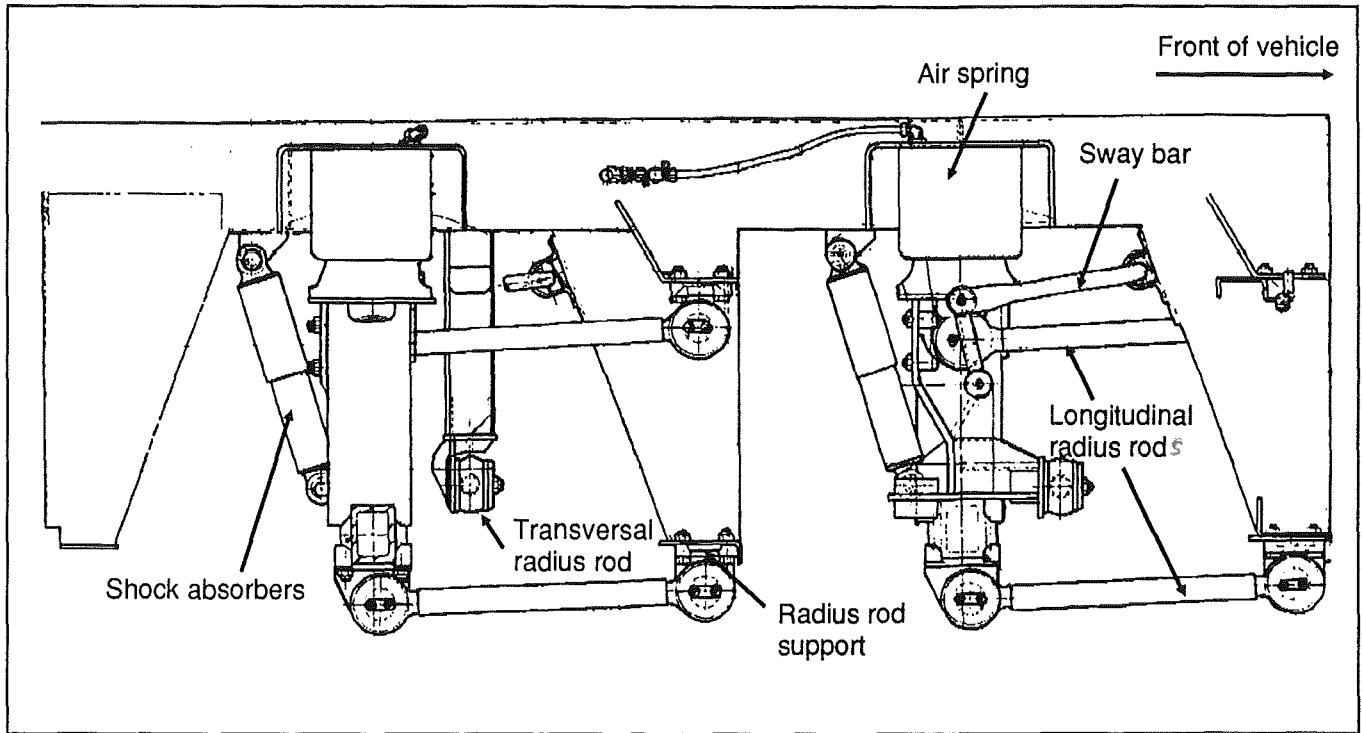

FIG. 2 - Front axle suspension components

MA5-1402.IMG

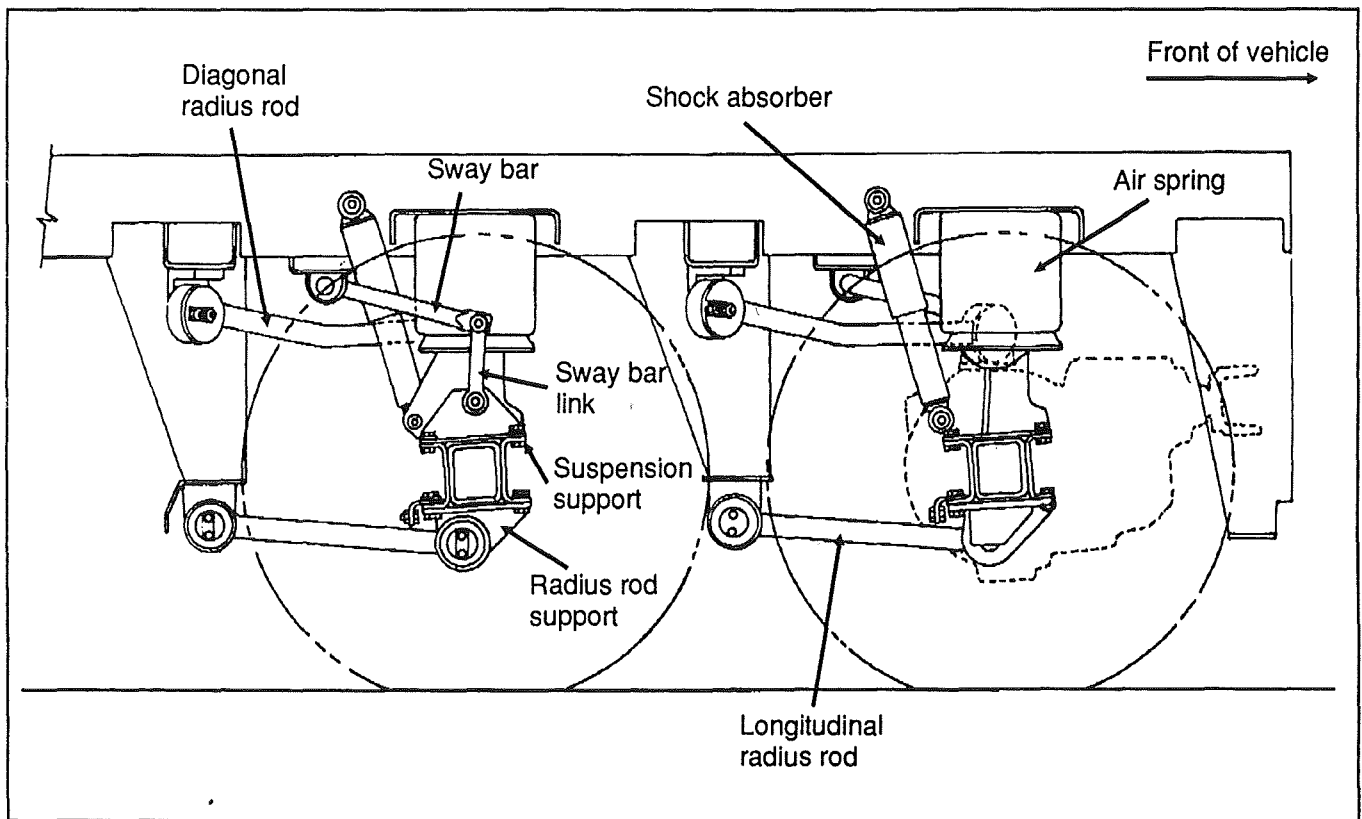

FIG. 3 - Drive axle suspension components

MA5-1403.IMG

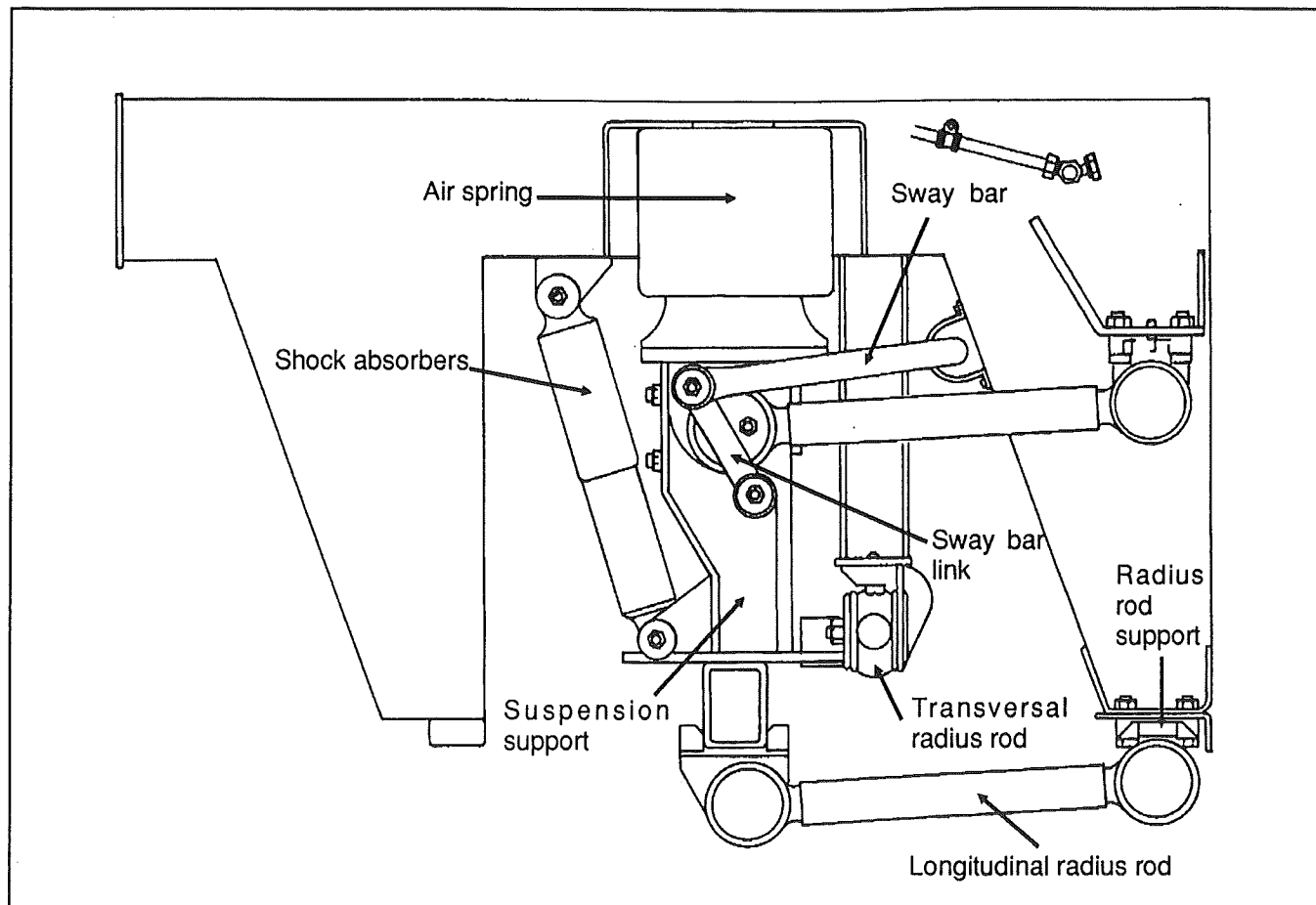

FIG. 4 - Axle 5 suspension components

MA5-1423.IMG

Delay-type height control valves increase or decrease the air pressure in the suspension system as required. One height control valve is located at center of axle 1, and regulates air to axle 1 and 2 air springs in order to maintain the vehicle to the required height (see figure 5). Two are located at the drive axles (axle 4), one on each side, and another valve is mounted in center of rear section axle.

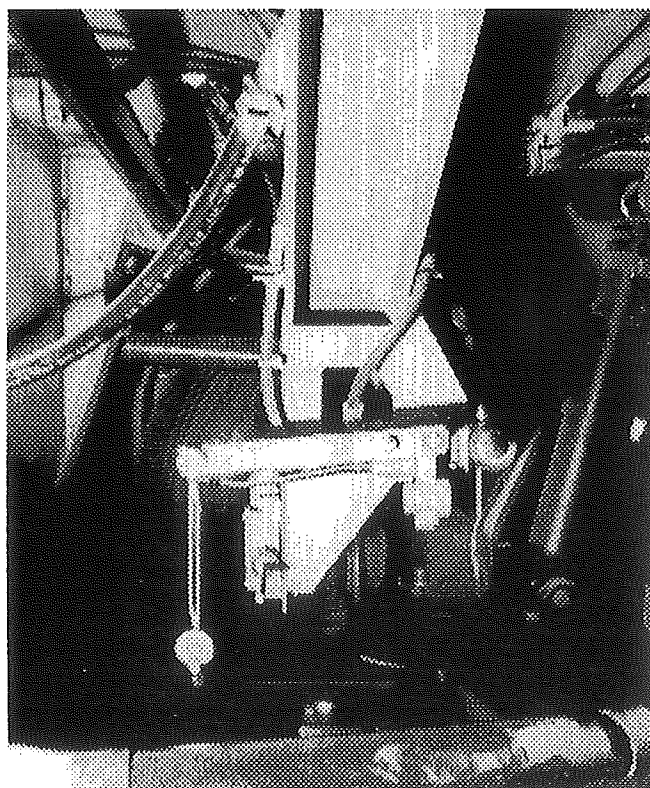

FIG. 5 - Axle 1 height control valve installation

MA5-1405.IMG



## AIR SPRING MAINTENANCE

### Air spring removal

**NOTE:** Suspension air springs (front, drive, and rear axles) may be removed without removing the entire axle assembly.

1. Raise and block the vehicle body on axle which has the defective air spring, according to the procedure outlined under "Axle removal and replacement" in the proper section.

2. If the system is under pressure, disconnect the height control valve link and pull down the overtravel lever to exhaust air from the air spring.

**NOTE:** When proceeding with this step, do not change the height control valve overtravel lever adjustment.

3. When air is exhausted, disconnect the air line from the air spring by unscrewing the fitting on top of air spring.

4. At top of air spring, remove the two (2) nuts and washers from the studs which secure the air spring to the subframe.

5. Remove the two (2) air spring lower nuts from suspension support, then the air spring.

### Air spring disassembly

**WARNING:** Use tool #19-0002 to disassemble air spring (see figure 6).

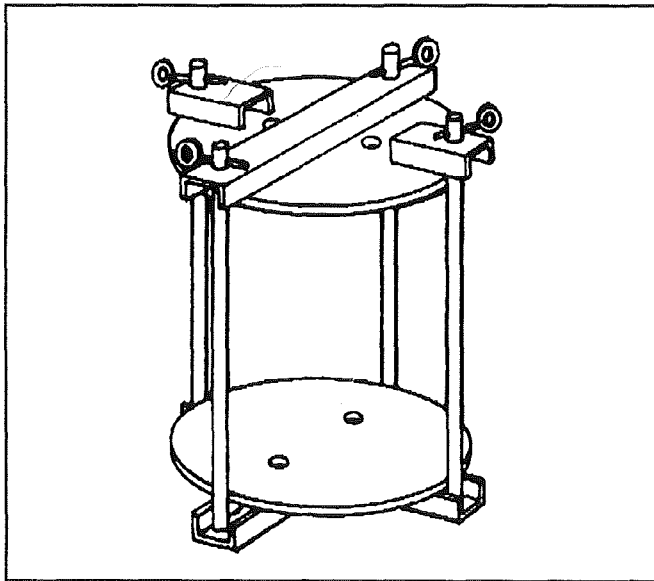

FIG. 6 - Tool #19-0002

MA5-1406.IMG

1. Install the air spring as shown, and slowly add air pressure through the fitting in the upper retainer plate. This will disassemble the lower retainer from the bellows (see figure 7 and 8).

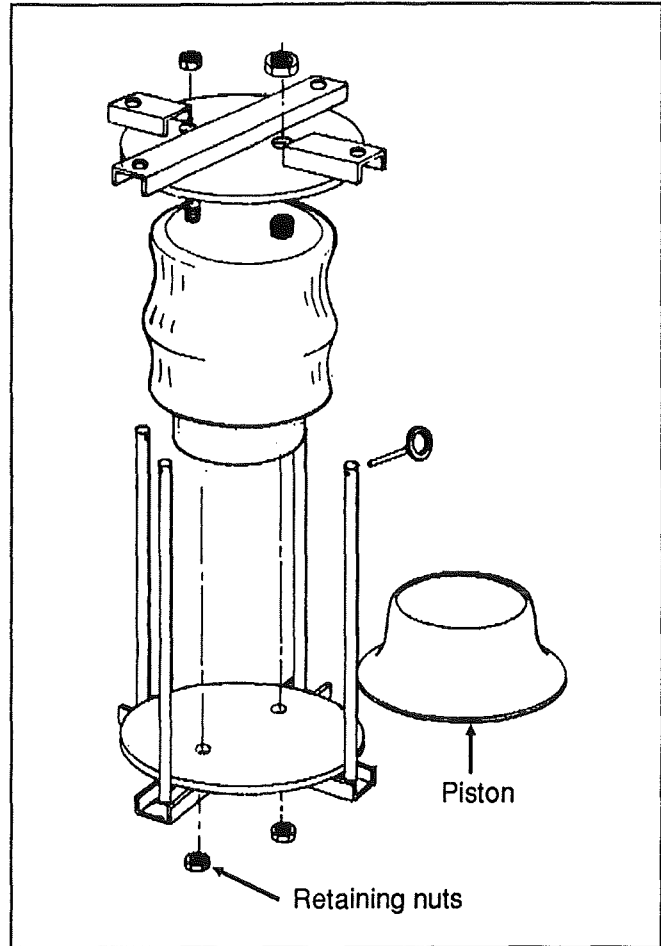

FIG. 7

MA5-1407.IMG

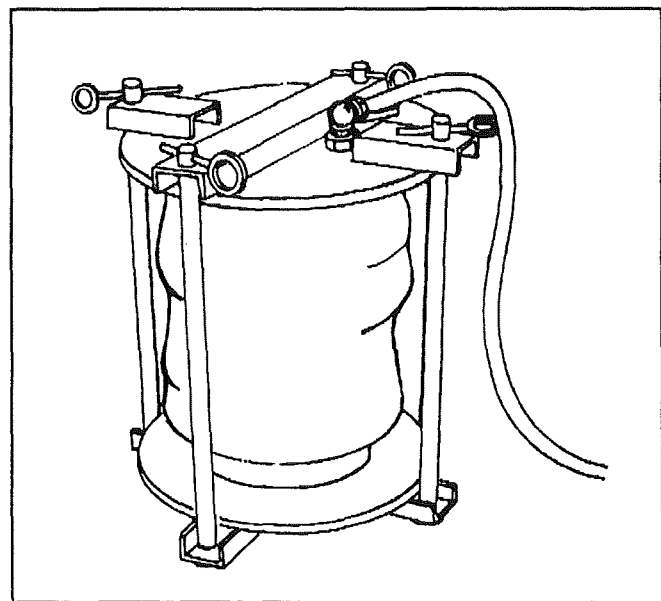

FIG. 8

MA5-1408.IMG

- Remove air spring from tool #19-0002.
- Proceed with the removal of the upper retainer. Use a rubber hammer and tap on the upper retainer until it is loosened from the bellows bead (see figure 9).

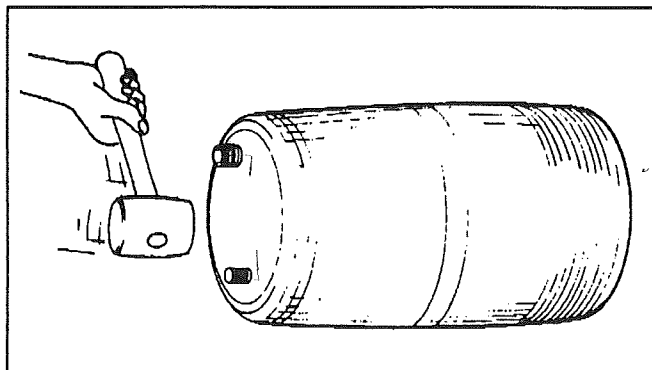

FIG. 9

MA5-1409.IMG

- Rotate upper retainer in order to align its two (2) flat surfaces with the wall of bellows, then press on it to elongate the opening and remove the upper retainer by pulling it out (see figure 10).

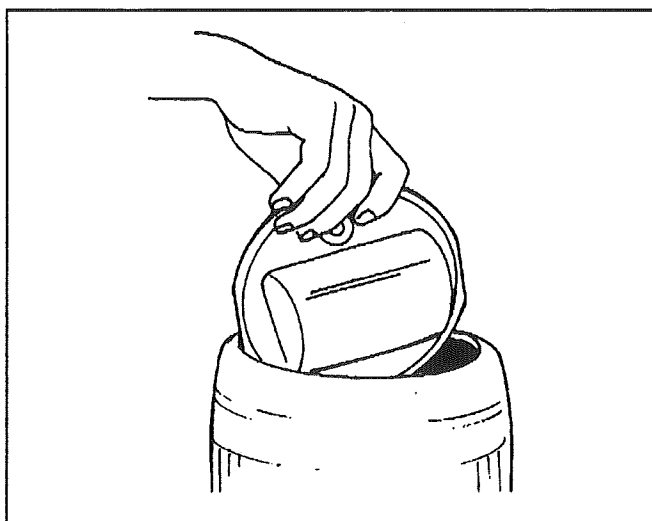

FIG. 10

MA5-1410.IMG

MA5-1410.IMG

- Apply liquid soap or glycerine to the lower retainer surface at the point of contact with the bellows. Force a screwdriver between the bellows bead and the retainer to allow the fluid to lubricate the bead.
- When bead is loosened around the entire surface of the lower retainer, the retainer can be forced into the bellows and removed through the upper opening (see figure 11).

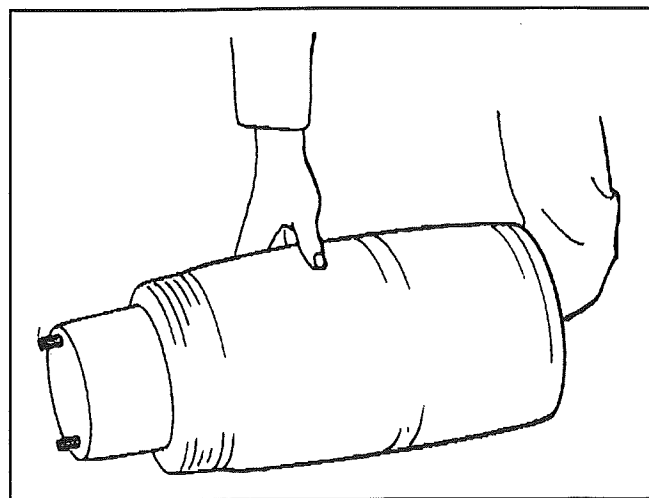

FIG. 11

MA5-1411.IMG

### Air spring inspection

- Clean bellows and bellows bead plates thoroughly.
- Inspect bellows inside and out for evidence of cracks, punctures, deterioration, or chafing. Replace the bellows if any damage is evident.
- Inspect the lower and upper bellows bead plates and the piston for dents, cracks, burrs or other damage that could cause air leaks. All surfaces contacting the bellows must be smooth to prevent damage to the bellows.
- Check mounting studs on bead plates for damaged or stripped threads. Threads on fitting holes should be in good condition.

**NOTE:** Bellows can be lightly inflated and submerged in water to detect any leakage. If any leakage is detected between bellows and bead plates, or in the rubber section, replace the bellows assembly.

**WARNING:** To prevent personal injury, do not apply more than 10 psi (69 kPa) air pressure with the air spring unmounted.

### Air spring reassembly

- Install the lower retainer through the upper opening of the bellows and position it in the lower opening, seating it as nearly as possible by hand.

**NOTE:** The use of silicone lubricant is recommended to facilitate this procedure, and we suggest that you apply a slight pressure on the lower retainer to ensure its complete seating in the bellows skirt.

- Apply silicone lubricant at top of the skirt, then press the bellows to elongate the opening and insert the upper retainer into the bellows. Position the upper retainer so that the bead will seat when air is applied (see figure 12).

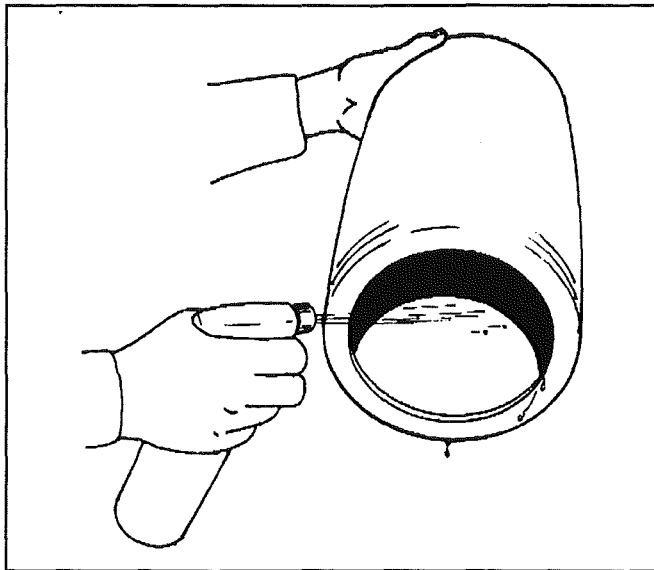

FIG. 12

MA5-1412.IMG

**CAUTION:** Ensure the upper and lower studs and nuts are positioned 90° apart, i.e, top studs must be perpendicular to bottom studs.

3. Slowly apply air (10 psi/69 kPa) through the opening in the upper retainer stud to properly seat the lower and upper retainers in the bellows.

4. Release the pressure from the air spring, then place partially assembled air spring on the piston (see figure 13).

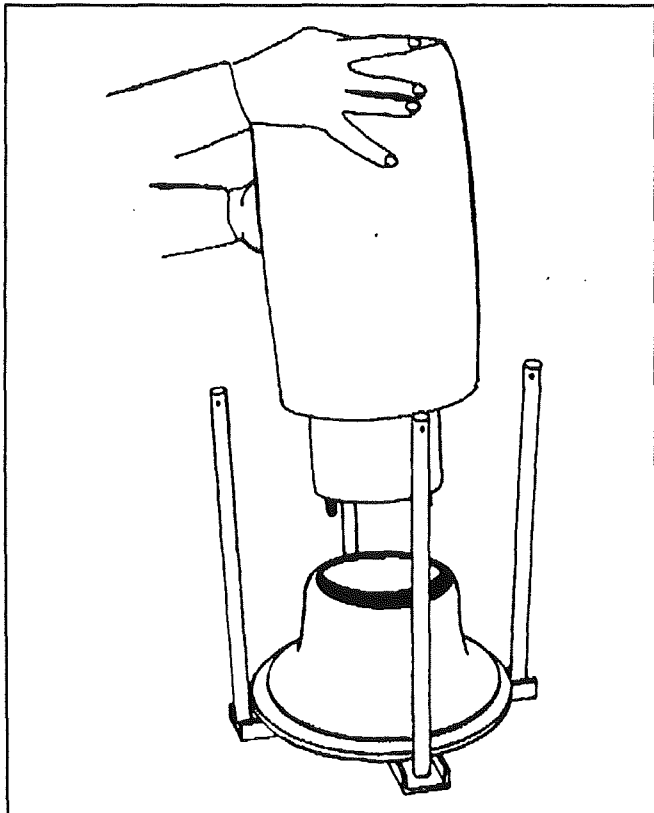

FIG. 13

MA5-1413.IMG

5. Use tool #19-0002, place the bellows inside the tool and apply air pressure (90 psi/620 kPa) in order to seat the bellows assembly components (see figure 14, 15 and 16).

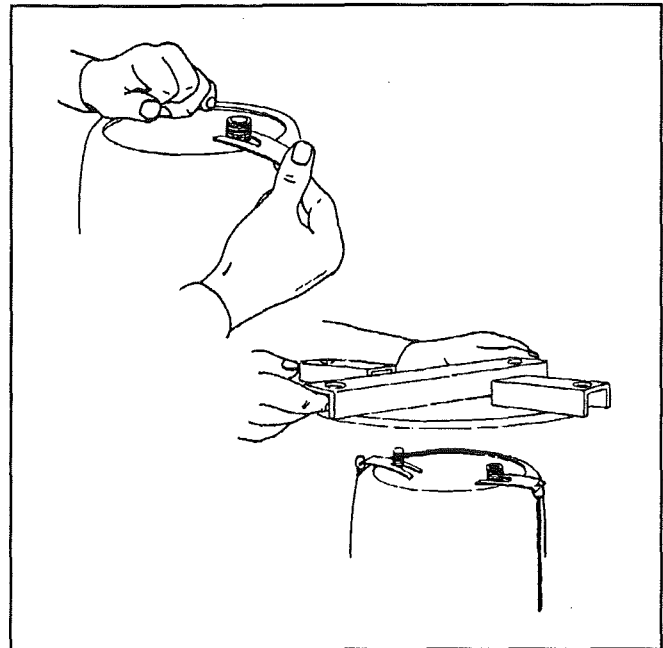

FIG. 14

MA5-1414.IMG

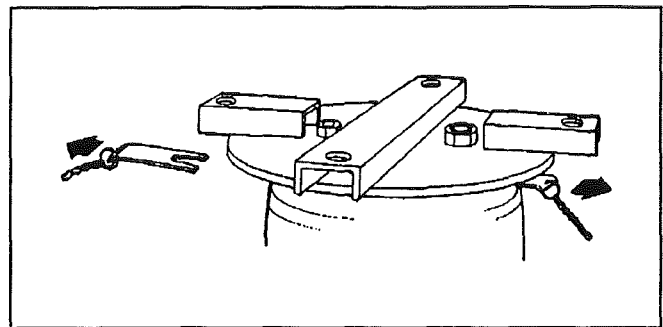

FIG. 15

MA5-1415.IMG

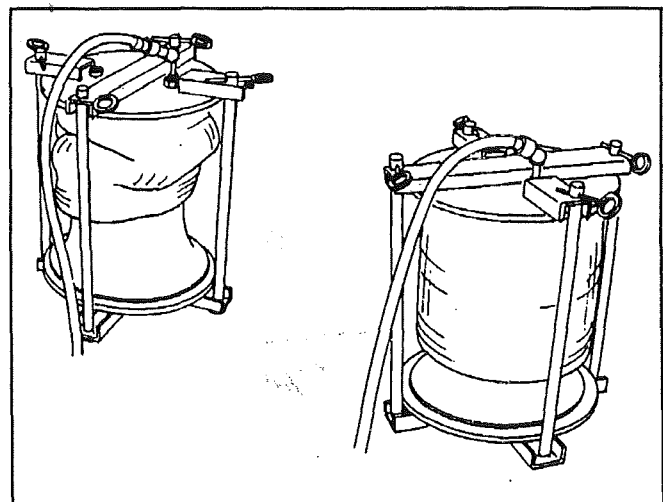

FIG. 16

MA5-1416.IMG

6. Remove bellows from tool #19-0002, then roll it down over the piston by placing a thumb over the air fitting, and while pressing down on the bellows with the heel of the hands, allow air to slowly escape from under the thumb.

**CAUTION:** Be careful not to dislodge the upper retainer from the bellows during this operation.

## Air spring installation

1. Compress the air spring assembly, then place the rubber pad on top of the air spring with the upper retainer studs through the holes in the rubber pad.
2. Position the air spring on the bellows support (with air fitting facing you) with the lower bellows bead plate studs through holes in lower support; start nuts to retain bellows to lower support.
3. Position the upper mounting studs through the upper bellows support on subframe, then install and start the nut on small stud.
4. Tighten and torque the lower stud nuts of bellows to 15 - 20 ft.lbs (20 - 27 N.m).
5. Torque the upper small stud nut to 8 - 12 ft.lbs (11 - 16 N.m).
6. Install the nut on the large hollow stud. Torque the nut to 95 - 120 inch.lbs (10,5 - 13 N.m).
7. Connect the air line to the hollow stud at the top of the air spring.
8. Reconnect the height control valve link.
9. Build up air pressure in the spring to normal operating pressure.

**NOTE:** To accelerate this operation, air reservoirs can be filled from an exterior air supply connected to the accessories tank fill valve or to the emergency fill valve.

10. Remove the jack stands from under the vehicle and lower it to the floor.
11. Check operation of bellows, and check for air leaks by coating the upper and lower mountings of the air spring with a soap and water solution. Any leak, showing up as bubbles, must be corrected. No leakage is permissible.

## SHOCK ABSORBER MAINTENANCE

Shock absorbers are nonadjustable and nonrepairable. Maintenance requirements involve replacement of the rubber mounting bushings, and tightening of all shock absorber pins at the proper torque when shock absorber replacement occurs. If a shock absorber becomes inoperative, complete unit must be replaced.

**CAUTION:** Always replace shock absorbers on each side of an axle when replacement occurs, except when covered mileage between both is very close. The following method will help you in determining if both shock absorbers on the same axle have to be replaced.

Loosen lower mounting of both shocks, then carefully attempt to raise and lower the bottom portion of each shock. Note the rate of effort-for-distance of travel. Replace both shocks if a definite differential rate is found.

The shock must be bench checked in an upright, vertical position. If checked in any other position, air will enter the cylinder tube and make the shock absorber appear defective.

**CAUTION:** On this vehicle, the front axles (1 & 2) are provided with softer shock absorbers, which are red colored or provided with a red tag. Thus, it is very important to replace shock absorbers with an identical model.

## Shock absorber diagnosis

Proceed as follows to check shock absorbers:

1. With the shock absorber in a vertical position (top end up), clamp the bottom mount in a vise.

**CAUTION:** Do not clamp the reservoir tube or the dust tube.

2. Rotate the dust tube. Notice any binding condition (may be compared with new unit). Binding condition indicates a scored rod. Units with scored rods should be replaced.
3. Fully extend shocks and examine for leaks in the seal cover area. Shock fluid is a very thin hydraulic fluid which has a characteristic odor and dark brown tint. A slight trace of shock fluid around the seal cover area is not a cause for replacement. The shock seal is designed to permit a very slight seepage to lubricate the rod. Units which leak should be replaced.
4. Visually check shock for dents which could cause the shock to bind. Also, check for a bent rod.
5. Extend and collapse shock to determine that it has control (resistance) in both rebound and compression.
6. Visually inspect the shock mountings and vehicle mountings for:
  - a) Broken mounts.
  - b) Extreme bushing wear.
  - c) Shifted bushing or sleeve.
  - d) Deep cracks in bushing material (shallow surface cracks are normal).
  - e) Loose shock absorber pins.
  - f) Presence of convex washers, and position of them according to the rubber bushing.

## Shock absorber removal

1. Remove nuts and washers from shock absorbers on upper and lower mounting pins, taking care to identify the inner and outer washers to ease reinstallation. Refer to figure 17 for details.

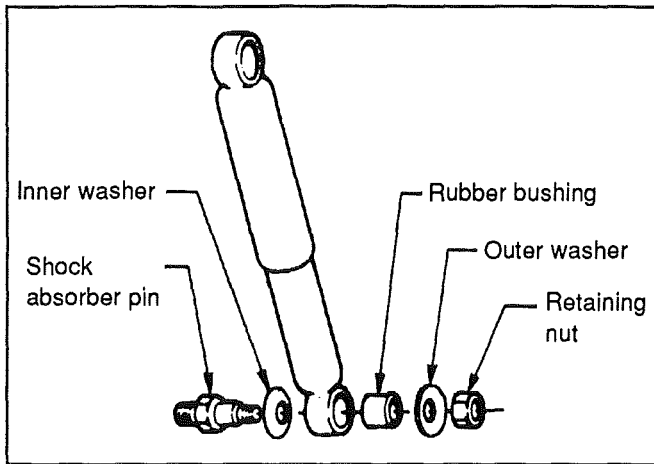

FIG. 17

MA5-1417.IMG

2. Remove the shock absorber assembly from pins.
3. Remove the two inner bushings from the shock absorber, then discard them.

## Shock absorber installation

1. Ensure that the shock absorber mounting pins are tight and that the threads are not stripped.
2. Install new rubber mounting bushings on shock absorbers (upper & lower).
3. Place the inner washers (with washer convex side facing the shock absorber rubber bushing) on each shock absorber pin (see figure 18).

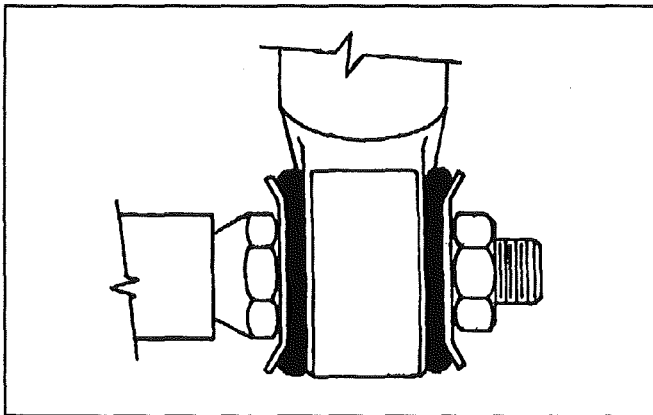

FIG. 18

MA5-1418.IMG

4. Install the shock absorber eyes over the mounting pins, then the outer washers (with washer convex side facing the shock absorber rubber bushing) on each shock extremities.

5. Place the lower and upper mounting pin stud nuts and tighten them to the recommended torque specifications (see heading "Specifications" at the end of this section).

## RADIUS ROD MAINTENANCE

### Radius rod inspection

The following instructions apply to all radius rods used on this vehicle.

1. Clean all parts thoroughly.
2. Inspect radius rods for distortion and cracks. We recommend the "Magnaflux" process to detect cracks in the radius rod. Any damaged part should be replaced with a new one.

**NOTE: New bushings should be used when rods are replaced.**

3. The radius rod bushings should be checked periodically for signs of shearing, deterioration, or damage. Any defective part should be replaced with a new one.

### Radius rod removal

1. Flatten the tab washer which secure the two retaining nuts, then unscrew the nuts at each extremity (see figure 19).
2. Remove the retaining plates and radius rod ends from anchor pins, then remove the radius rod.

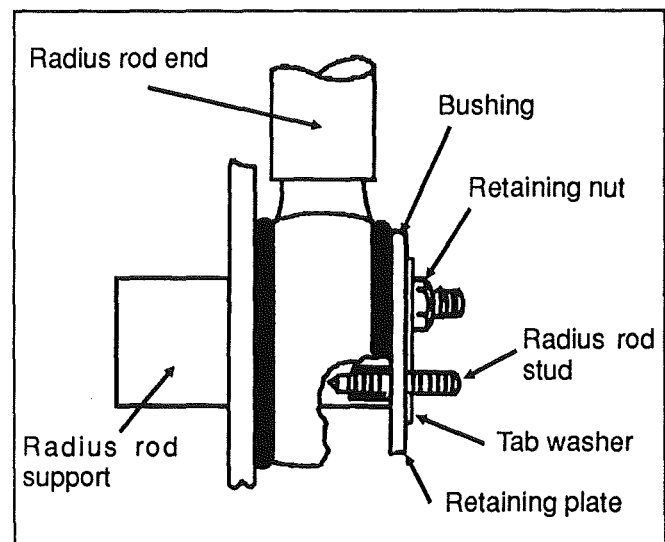

FIG. 19

MA5-1419.IMG

## Radius rod bushing removal

1. Safely support the radius rod as shown in figure 20.
2. Place a flat steel disc, slightly smaller than the outside diameter of the bushing (see figure 20).

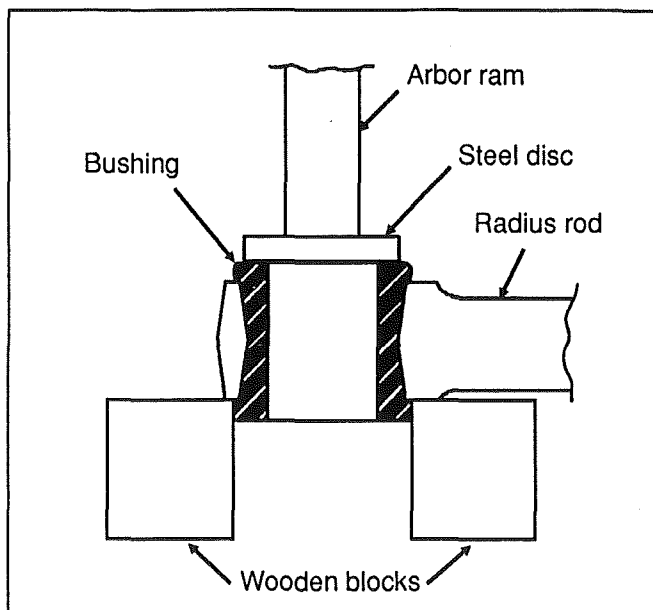

FIG. 20 - Removing radius rod bushings

3. Using an arbor press or a suitable driving tool, press or drive the old bushing out of the rod and discard the bushing.

## Radius rod bushing installation

1. Spray lightly the inner and outer diameters of radius rod bushing with water.

**CAUTION: No lubricant whatsoever is to be used on the rubber bushing.**

2. Safely support the radius rod, and place new bushing on top of the radius rod end.
3. Place a block of wood on top of bushing and press on it manually.
4. If necessary, use an arbor press or a suitable driving tool; press or drive the bushing into the radius rod end until it extends equally on both sides of the rod.
5. It is also possible to proceed differently. Place radius rod bushing on a plane surface, then spray a light coat of water on the inner and outer diameter surfaces of radius rod and bushing.
6. Take radius rod, align the bushing, then tap radius rod on bushing until latter is positioned correctly.

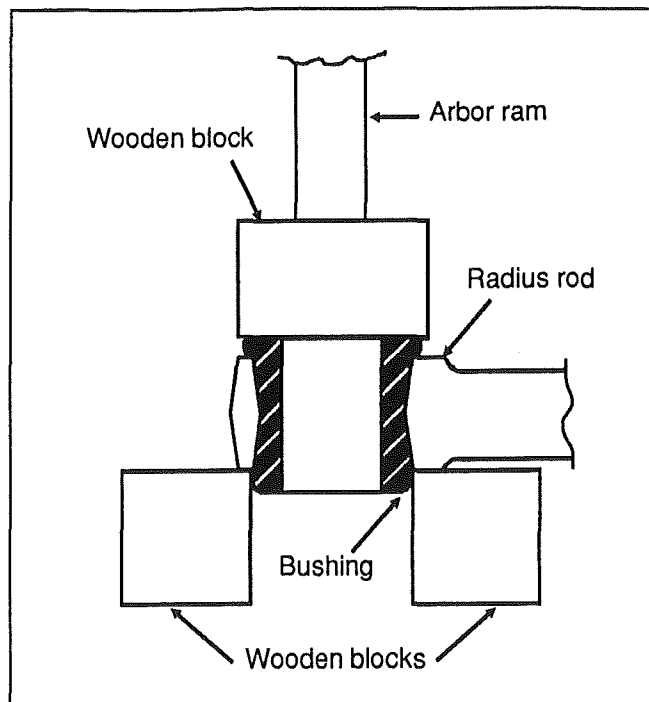

FIG. 21 - Installing radius rod bushings

## Radius rod installation

1. Spray lightly the anchor pin with water, then place the radius rod end over the anchor pin.
2. Position the retaining washer, then install the tab washer and nuts.

**CAUTION: Always use new tab washers at installation.**

3. Tighten the nuts lightly, and repeat at the other end.
4. Refer to heading "*Suspension height adjustment*" later in this section, and set the vehicle to normal ride height.
5. With the vehicle at normal ride height, tighten all radius rod anchor pin nuts to the torque listed under the heading "*Specifications*" later in this section.

**CAUTION: It is extremely important upon reconnection of the rods that the proper clearance height between the axle and body is maintained, otherwise the rubber bushings in radius rod ends will become preloaded, thus reducing the life of these parts.**

## SWAY BAR MAINTENANCE

### Sway bar removal

1. Remove the nuts and washers from the upper and lower ends of the sway bar link.
2. Repeat step 1 at the opposite side of the sway bar, then remove both sway bar links.
3. Remove the washers on the lower sway bar link studs.
4. Support the sway bar and remove the eight (8) retaining bolts which secure the four (4) sway bar bushing collars to the subframe, then remove the bushing collars.
5. Remove the sway bar from beneath the vehicle.
6. If necessary afterwards, the sway bar bushings may be removed from the sway bar by splitting them apart.

### Sway bar installation

1. After replacing bushings, ensure they are properly positioned on the sway bar, then position the sway bar under the vehicle. While supporting the sway bar, mount the sway bar to the vehicle subframe by positioning the four (4) sway bar bushing collars over the four (4) bushings, and secure them to the subframe with the eight (8) retaining bolts. Tighten them manually.
2. Remove any dirt, grease or other foreign matter from the sway bar studs.
3. With the vehicle at normal ride height, replace the washer on the lower sway bar link stud, then install the links on each side (see figure 22).

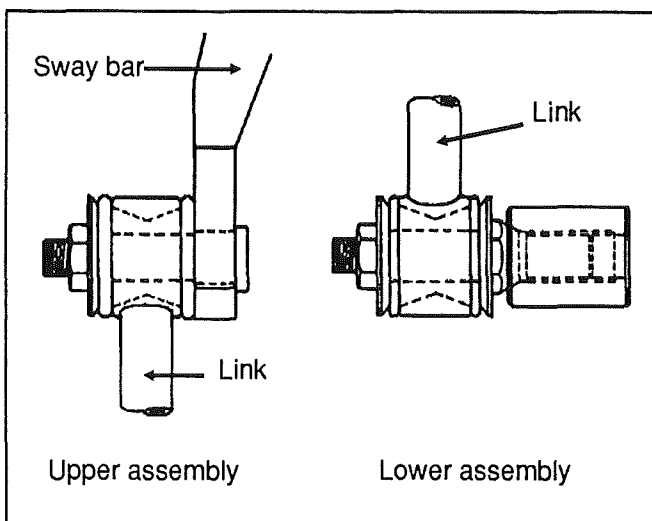

FIG. 22 - Sway bar line installation

4. Replace the washers and nuts.
5. Tighten the sway bar bushing collar bolts (8), the lower and upper link pin stud nuts to the torque given under heading "Specifications" at the end of this section.

## SUSPENSION AIR SYSTEM MAINTENANCE

### System description

The suspension air system has its own air reservoir (accessory tank) which receives pressurized air from the main air supply reservoir. Air from the main air system is filtered by a filter (located in front service compartment), and then flows through a pressure protection valve (PR-4). This valve closes if suspension tank air pressure is depleted due to a severe leak in the suspension air system.

The flow of pressurized air from the air tank (accessory tank) to the air springs is controlled by four (4) height control valves. These valves are mounted to the subframe and connected to the axles through an arm and link connection. This connection allows the valves to apportion air pressure in the springs to the vehicle load, maintaining normal ride height. A delay piston in each valve causes time lapse reponse of the valves, so that air pressure in the springs is adjusted only during changes in vehicle load and not during intermittent road bumps. The front height control valve is interconnected with the kneeling system; when the kneeling system is in use, it will bypass the height control valve. This prevents the height control valve from supplying air to raise the vehicle, while the kneeling system is attempting to lower the front of vehicle. Refer to figure 1 for more details.

### Suspension system inspection

The following inspection should be performed at established service inspection periods. Performing the procedures will allow substandard performance to be discovered before the condition becomes bad enough to cause operator complaints and failure on a run.

1. Visually inspect the suspension air lines for evidence of chafing on metal parts or other damage.
2. Visually inspect the air springs for cracks, abrasion or other damage.
3. Replace any parts found to be damaged.

### Suspension air line test

With the main air system at normal operating pressure, coat all suspension air line connections and air spring mountings with a solution of soap and water. Air leakage will produce soap bubbles. Any leak found must be corrected as no air leakage is permissible.

## Suspension air tank maintenance

Refer to section 10 "Brakes and air system" under heading "Air reservoir maintenance" for complete instructions on air tank maintenance.

## SUSPENSION HEIGHT ADJUSTMENT

To ensure correct vehicle ride height, it is necessary to check and adjust, if required, the height control valves. The right vehicle body height which should be maintained is shown in figure 23. It should not be necessary to make an adjustment at this point under normal service conditions. However, if an adjustment is necessary, it is made by changing the position of the overtravel lever in relation to the overtravel control body. The lever should be moved up to raise the level of the vehicle, and down to lower it. Check that main air pressure is at normal operating pressure and raise the vehicle to the specified height.

**CAUTION:** Always adjust on "fill cycle". If it is necessary to lower vehicle height, release sufficient air to be well below height, and adjust to height or fill cycle.

To adjust suspension height, proceed as follows:

1. With the vehicle at normal operating air pressure, check the clearance between the axle and the body (refer to figure 23). This dimension should be 12" (305 mm)  $\pm$  1/8" (3 mm) on all axles.

**NOTE:** The measure should be taken from under the upper air spring support on subframe to top of the lower air spring support on axle (refer to figure 23 for more details).

2. If dimension is incorrect, remove the nut and washer which attach the height control valve link to the link mounting bracket on the axle (see figure 24).

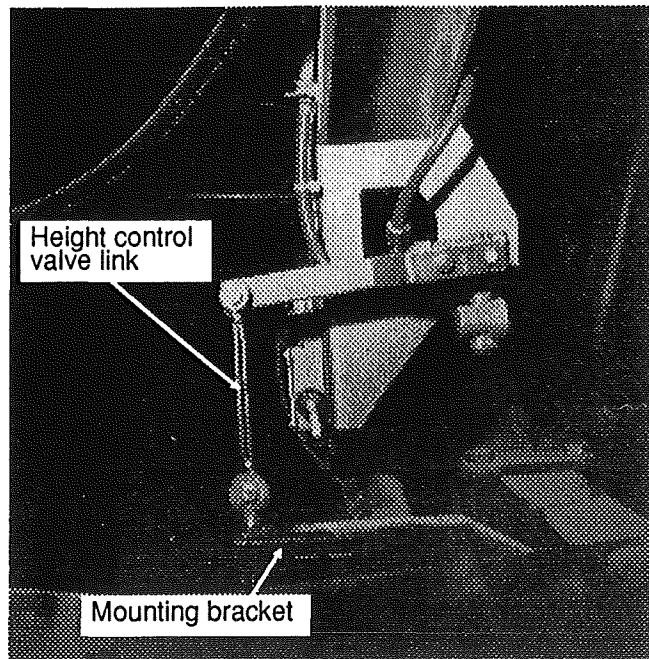

FIG. 24

MA5-1424.IMG

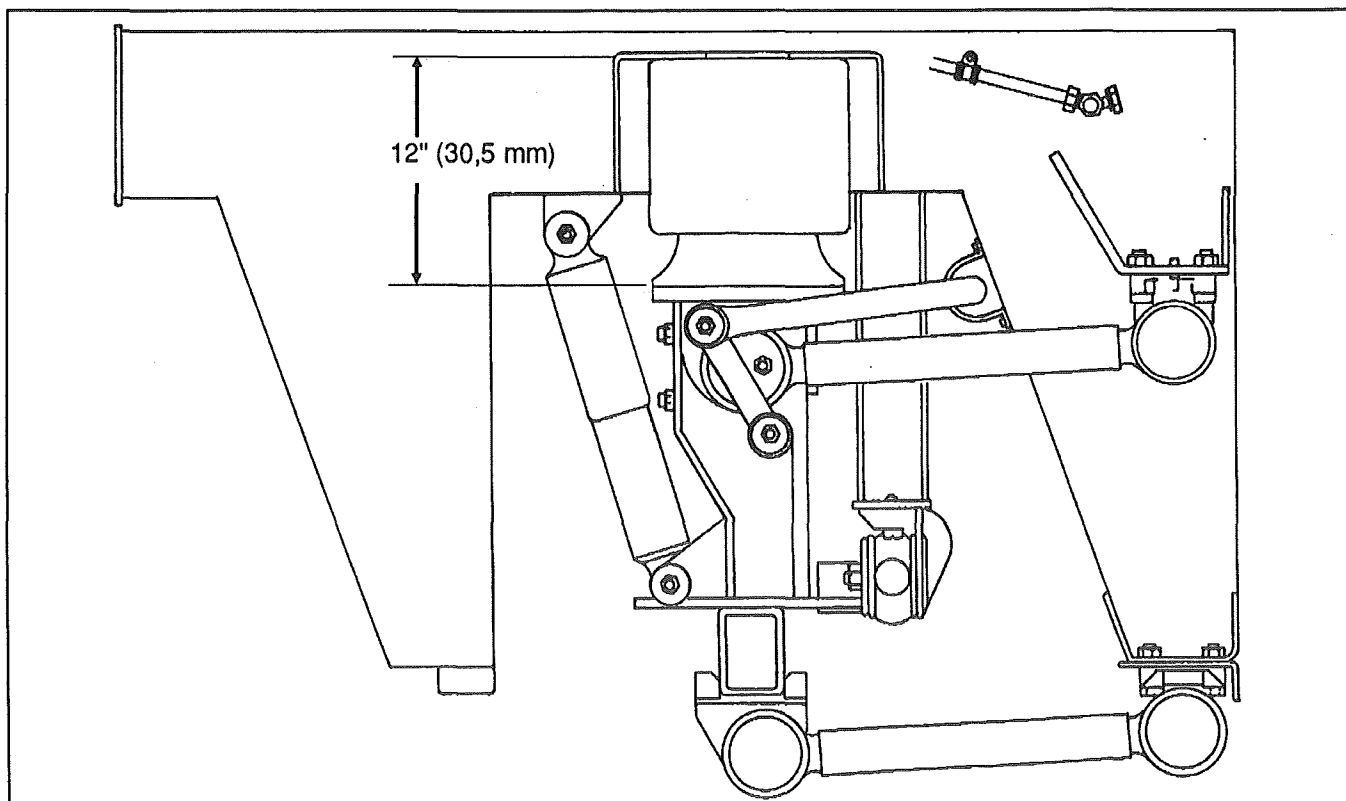

FIG. 23 - Clearance between axle and body (same on all axles)

MA5-1423.IMG



3. Raise or lower the overtravel lever to cause the vehicle body to raise or lower until the desired dimension is reached.

**NOTE: Allow suspension to stabilize before taking reading.**

4. When the proper height is obtained, adjust the nut on the threaded rod attached to the overtravel lever, replace the washer and nut which attach the threaded rod to the link mounting bracket, then tighten this nut.

## HEIGHT CONTROL VALVE OPERATION

Figure 25 shows a cross-section of a height control valve in its three operating phases. Valve operation is illustrated as the vehicle is unloaded, at normal ride height, and as the vehicle is loaded. Each valve adjusts independently according to the following conditions:

### LOADING POSITION

When loaded, body of vehicle settles. Since valve is linked to suspension, and valve is mounted to vehicle body, valve moves downward with body during loading. As overtravel lever and control shaft turn, intake valve lever presses against pin of valve core. As pin is depressed, air pressure flows through height control valve and into air springs. Increased air pressure expands air springs and raises body of vehicle. Intake valve is protected by a check valve which permits air to travel in one direction only.

### NEUTRAL POSITION

Increased pressure expands air springs, thus lifting vehicle body and height control valve. The overtravel lever returns to "NEUTRAL" as vehicle body approaches normal ride height. Intake valve lever also moves closing valve. The exhaust valve remains closed, and the check valve in intake adapter prevents air escape from valve body and air springs. This condition remains static until vehicle load is altered, moving overtravel lever to "NEUTRAL" for one second or longer, actuating intake or exhaust valve.

### UNLOADING POSITION

When load is lightened, pressure in air springs raises vehicle body. Overtravel lever is pulled downward from "NEUTRAL". This applies a force that slowly moves the delay piston, and opens exhaust valve when lever moves beyond free travel range. Intake valve remains closed, thus allowing air from air springs to exhaust to atmosphere. As air is exhausted from air springs, the vehicle body is lowered until overtravel lever returns to "NEUTRAL" position.

When vehicle is in motion with body at normal ride height, overtravel lever is in "NEUTRAL" position. Small movements of lever may occur without activating control valve as it must move in excess of 3/16" (4,7 mm) before either valve is opened.

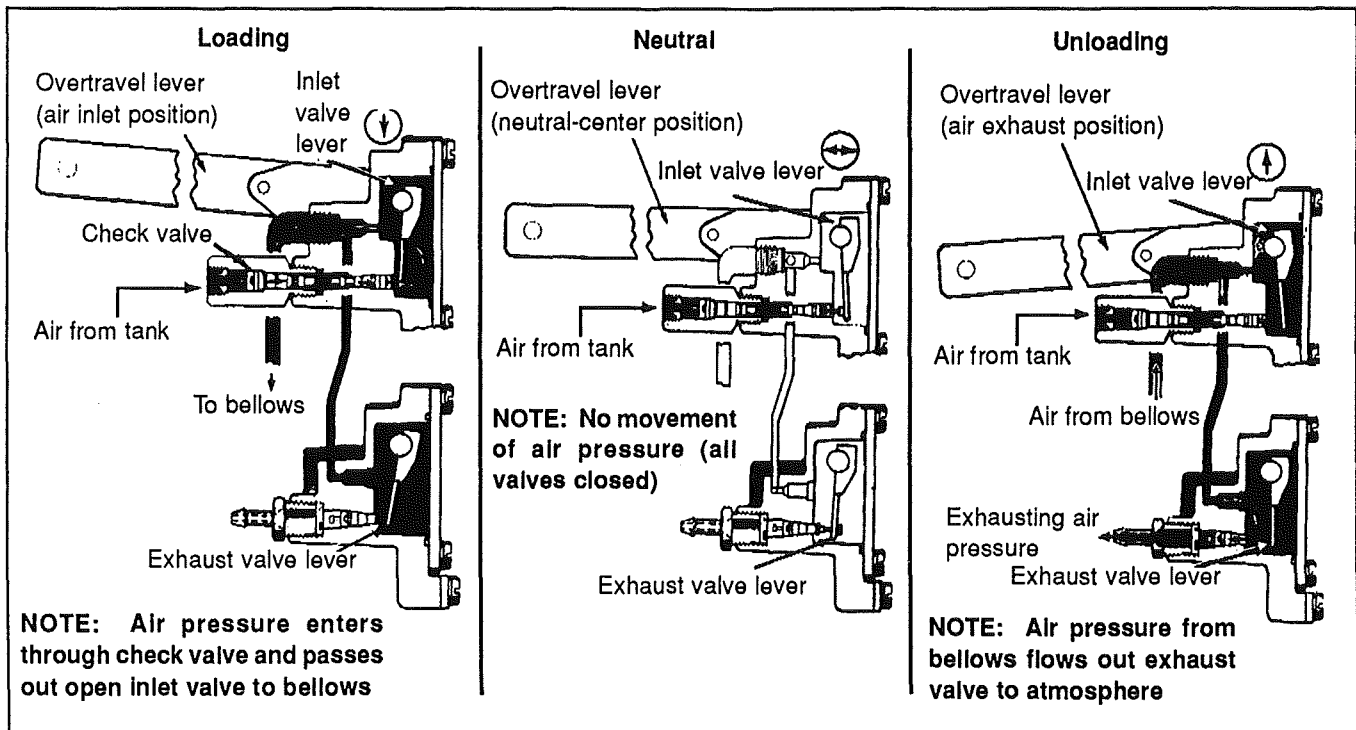

FIG. 25 - Operation of height control valve

MA5-1425.IMG

The delay piston, connecting through a pin to the overtravel shaft is contained in a cylinder of silicone-type fluid. The slowing action of this fluid delays from 1 to 6 seconds between the closing of one valve and the opening of the other. The flapper valves allow both valves to close from full-open position within 1 second.

The overtravel piston is held against shaft by two springs (one inside the other) and keeps shaft in proper position relative to the overtravel lever. Purpose of the piston is to prevent damaging the parts inside control valve if lever exceeds normal travel, and to allow the lever to move without moving parts inside the valve.

## Height control valve maintenance

The height control valve requires no periodic maintenance. Height control valve linkage operates on rubber bushings and no lubrication at this point should be attempted.

## Height control valve removal

Before disconnecting any height control valve air lines, securely support the vehicle by its jacking points on the body. Refer to heading "*Vehicle jacking points*" in section 17 "*Body*".

1. Exhaust the air from the air supply system by opening the drain cock on each air reservoir. Remove height control valve as follows.
2. Disconnect overtravel lever from link and pull down lever to exhaust remaining air from air springs.
3. Disconnect air supply and delivery lines from the height control valve, then cover ends of the lines with tape.
4. Remove the two (2) nuts retaining the height control valve to the mounting bracket, then remove valve assembly.

## Height control valve installation

Reverse removal procedure to replace height control valve. After installation, check for leakage using soap and water.

## Height control valve air leakage check

**NOTE:** The following procedure applies when valve assembly has been removed from vehicle.

1. Clean the exterior of valve assembly.
2. Connect air pressure line to air inlet port, then open the air pressure (70-100 psi/480-690 kPa).
3. Dip the valve assembly in a container of water, and watch for air bubbles when the overtravel lever is in the center position. No air should escape from any point of the valve assembly.
4. If bubbles appear from the air spring port, this is an indication that the air inlet valve assembly is defective and must be replaced.
5. Remove air pressure line from air inlet fitting and connect it to the air spring port. If bubbles appear at the air inlet check valve port, this is an indication that check valve unit is defective and must be replaced.
6. If bubbles appear at the exhaust port, this is an indication that the exhaust valve assembly is defective and must be replaced.
7. If bubbles appear around edge of valve cover plate, the cover plate gasket must be replaced.
8. If no leaks are found, remove valve assembly from water, then with air pressure still connected to the air spring port, actuate overtravel lever to remove any excess water which may have entered exhaust valve chamber. Remove air line, connect it to the air inlet port, and repeat operation to remove water from the air inlet valve chamber.

## SUSPENSION TROUBLESHOOTING

MALFUNCTION	POSSIBLE CAUSE	CORRECTIVE MEASURE
Bellows deflate over time.	Defective check valve assembly. Defective exhaust valve assembly. Leak in air line and/or bellows. Defective valve cover rubber O-rings or gasket.	Replace check valve assembly. Replace exhaust valve assembly. Replace air line or bellows. Replace valve cover, O-rings or gasket.
Bellows raise to full height and fail to exhaust air pressure.	A clogged exhaust screen in height control valve assembly. A combination clogged exhaust screen and defective air inlet valve assembly.	Remove and clean screen.  Clean exhaust screen and replace air inlet valve assembly.
Intermittent hissing noise at height control valve during operation.	Loss of time delay action fluid in height control valve assembly.	Add fluid, then install new cover and delay piston plug, gasket, O-rings.
Erratic valve action.	Dirt or foreign matter in the air valve lever chamber. Defective valves.	Remove valve cover and blow out dirt. Install cover using new gasket. Overhaul height control valve assembly.
Vehicle body fails to level to satisfactory ride height.	Improper height control valve over-travel lever adjustment.	Adjust lever as directed.

## KNEELING/HI-BUOY SYSTEM

### Description

The kneeling system is used to lower front of vehicle. This allows passengers to board the vehicle with greater ease. The kneeling action is accomplished by exhausting air from the front air springs (bellows). On this vehicle, the kneeling system is provided with an interlock braking system which applies automatically the parking brake when kneeling system is activated. The air outlets of air springs on axles 1 & 2 have a greater diameter which increase air flow during front kneeling operation. A large auxiliary tank located in reclining bumper compartment, provides a sufficient air supply to the system for at least two successive operations. Furthermore, these components allow a faster system operation: only five (5) seconds are required to lower vehicle from normal level to the lower position, and seven (7) seconds to raise the vehicle from lower position to one (1) inch lower than normal position. The hi-buoy system is the opposite of the kneeling system as it is used to raise the vehicle to allow an extra ground clearance for particular situations (ferryboat, avoiding a sidewalk curb, etc.).

### Maintenance

As these systems are interrelated with the air and electrical systems, refer to its applicable maintenance in sections 10 (Brakes and air system) and 15 (Electrical system) of this manual. Furthermore, problems resulting from an electrical defective part or circuit can often be solved by a careful analysis of the wiring diagram.

For the electric circuits of this system, refer to diagram #21/24 of the master wiring diagrams; as for the pneumatic circuits, refer to the air line diagram annexed to the end of section 10 "Brakes and Air System".

*BELLOWS CONTROL AND EXHAUST SOLENOID VALVES*

**Bellows and exhaust control solenoid valve**

**Removal**

1. Inside front service compartment, locate bellows and exhaust control solenoid valve (see figure 26), then disconnect the three (3) black hoses connected to this valve: two routed to the poppet valve at right, and the other at back routed to the accessories block manifold.

**NOTE: Identify each air hose (black) before disconnection, in order to ease reinstallation procedure.**

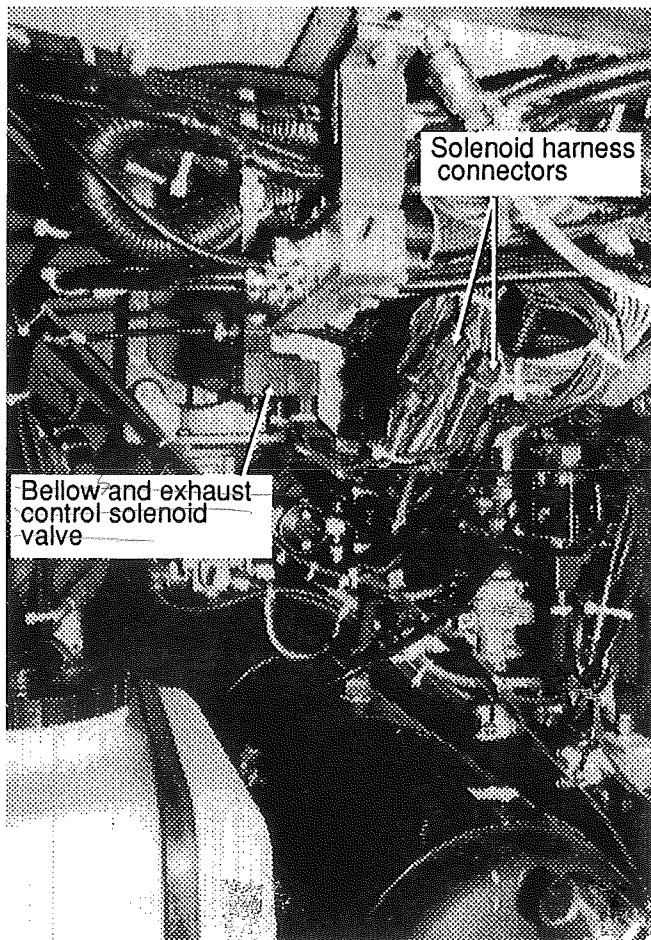

**FIG. 26 - Front service compartment**

2. Unscrew the two (2) retaining screws on valve mounting bracket, and remove cable ties on solenoid harness to remove valve assembly.
3. Disconnect the two solenoid harness connectors.
4. Remove valve assembly.

**Replacement**

1. Reverse removal procedure to install this valve.

**NOTE: If cable ties have been removed to ease operation, remember to replace them afterwards.**

**Kneeling sense switch assembly**

**Removal**

1. Disconnect the switch wiring connector, then unscrew the three (3) bolts, washers, and nuts (see figure 27) which attach the switch assembly to the mounting bracket.

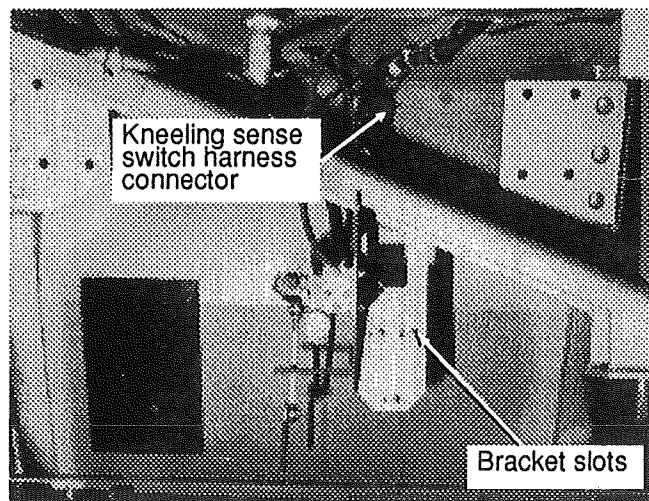

**FIG. 27 - Kneeling sense switch installation**

2. Remove switch assembly from vehicle.

**Replacement**

1. Fix the switch assembly to the mounting bracket with the three bolts, washers, and nuts. Then, torque the nuts to 95 - 120 inch-pounds.
2. Reconnect the switch harness connector.
3. Adjust the switch assembly in the bracket slots (refer to figure 27).
4. With the vehicle at normal ride height, check that there is 2 3/4" (70 mm) clearance between the bottom of the sense switch actuator and the actuator bracket.

*→ devrait être 1 1/4"  
selon dossier d'atelier*

## SPECIFICATIONS

### FRONT AXLE AIR SPRINGS

Make . . . . . Goodyear Tire and Rubber  
Model . . . . . Roll-over volume can  
Type . . . . . 1100  
Diameter . . . . . .11" (279 mm)  
Prévost Number . . . . . 63-0079 (Larger exit port)  
Supplier Number . . . . . .566-22-2-050

### DRIVE AXLE AIR SPRINGS

Make . . . . . Goodyear Tire and Rubber  
Model . . . . . Roll-over volume can  
Type . . . . . 1100  
Diameter . . . . . .11" (279 mm)  
Prévost Number . . . . . 63-0070  
Supplier Number . . . . . .1R11-044

### REAR AXLE AIR SPRINGS

Make . . . . . Goodyear Tire and Rubber  
Model . . . . . Roll-over volume can  
Type . . . . . 1100  
Diameter . . . . . .11" (279 mm)  
Prévost Number . . . . . 63-0079  
Supplier Number . . . . . .566-22-2-050

### FRONT AXLE SHOCK ABSORBERS

Make . . . . . Gabriel  
Collapsed Length . . . . . 15.4" (39,12 cm)  
Extended Length . . . . . 24.4" (61,98 cm)  
Quantity used . . . . . .4 (2/per axle)  
Prévost Number . . . . . 68-0080  
Supplier Number . . . . . 680223-40T  
Color . . . . . .Red





# 15

# ELECTRICAL SYSTEM

---

## CONTENTS OF THIS SECTION

GENERAL DESCRIPTION . . . . .	15-1
WIRING AND MISCELLANEOUS ELECTRICAL . . . . .	15-1
FRONT SERVICE COMPARTMENT . . . . .	15-4
BATTERY MAINTENANCE . . . . .	15-11
GEAR DRIVEN OIL-COOLED ALTERNATOR . . . . .	15-15
DIODE END COVER INSTALLATION . . . . .	15-22
ALTERNATOR REPLACEMENT . . . . .	15-22
ALIGNMENT OF ALTERNATOR ADAPTER ("8-SHAPED" ADAPTER) . . . . .	15-25
BATTERY EQUALIZER . . . . .	15-25
VOLTAGE REGULATOR . . . . .	15-26
STARTING MOTOR . . . . .	15-30
ENGINE HEATERS . . . . .	15-34
LIGHTING SYSTEM . . . . .	15-34
EXTERIOR LIGHTING EQUIPMENT . . . . .	15-35
INTERIOR LIGHTING EQUIPMENT . . . . .	15-39
SPECIFICATIONS . . . . .	15-43
LIGHT BULB DATA . . . . .	15-45





## GENERAL DESCRIPTION

The coach uses a dual voltage system to obtain two different voltages (12 & 24 volts) for various electrical controls and accessories. The main power source incorporates four maintenance-free "Delco" model 1150 batteries connected in series-parallel. All batteries are kept uniformly charged by means of two 50 amp battery equalizers, giving a maximum possible output supply of 100 amps on the 12 volt system. Both the 12 and 24 volt systems are controlled through individual main disconnect switches. A 24 volt self-rectified alternator is gear driven from the engine, and can be reached through an access panel in the A/C breaker & engine junction box & baggage compartment.

## WIRING AND MISCELLANEOUS ELECTRICAL

### Wiring diagrams

A master wiring diagram of the electric circuits, covering standard and optional accessories and systems, is supplied with the technical publication kit. Usually, a separate wiring diagram is provided for each major function or system. In some cases, a circuit on one diagram is tied into a circuit on another diagram and a cross reference is made to the other diagram. When this happens, a cross reference number is made to the other diagram. When a diagram consists of more than one sheet, the number(s) at the extremity of diagram title will indicate the sheet reference number. Refer to the "Wiring diagram index" to ensure the correct diagram is being used to trace the circuit in question.

### Wiring diagram symbols

Various symbols are used on the wiring diagrams to depict different types of electrical components. It is essential to become familiar with these symbols in order to understand the diagrams. The major symbols shown on the diagrams are identified under "Wiring diagram codes".

### Wire sizes and colors

Each wire in the electrical system has a specific size as designated on the wiring diagram. When replacing a wire, the correct size must be used. Never replace a wire with one of a smaller size.

On vehicles, taking into account that the electric system is provided with different voltages, the insulation on each wire is distinctly colored in order to determine visually the wiring voltage and to assist in making connections. The wires are color coded as follows:

Red	24 volt system
Yellow	12 volt system
Black	grounded wire
Blue	110 V ac system (live)
White	110 V ac system (neutral)
Green	110 V ac system (ground)
Orange	speakers (+)
Brown	speakers (-)

**NOTE:** The wires are still identified at each extremity by a printed number.

Each wire on a diagram is patterned to assist in tracing and testing circuits; the wire number is designed in order to identify at first, the voltage rating, then the wire identification number, and finally the basic wire gauge. Refer to example given in figure 1.

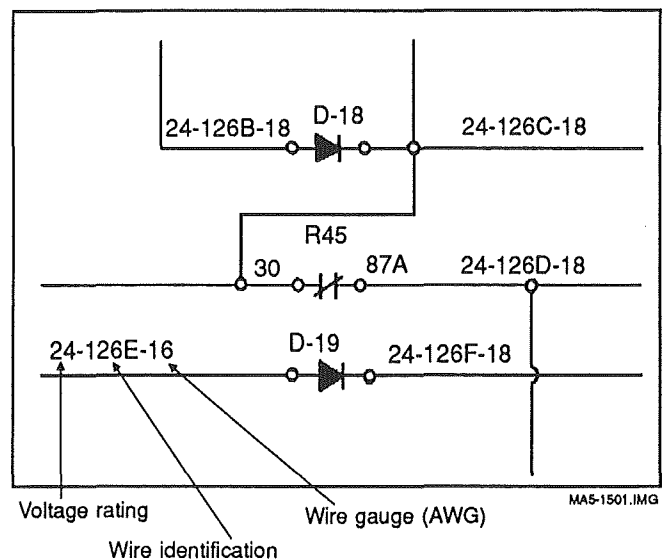

FIG. 1

### Using the wiring diagrams

Two methods are used to "work" with electric wiring diagrams.

1. You have identified the defective part (breaker, diode, relay, etc.), and you wish to locate its corresponding circuit.

**Problem:** Circuit breaker #56 is released (open circuit) and you don't know which circuit is affected.

- Refer to page A of main index, and look for "Circuit breaker code", pages D-1 and D-2.
- You will find that circuit breaker #56 is on page D-1; refer to this page.

c) At the item C.B #56, you will find in the first column, the breaker amperage, in the second column the breaker voltage, and in the third column, the page on which you will find the corresponding diagram. The other columns gives you the location and the function of the breaker.

d) Refer to page 13 keeping in mind the function of the breaker, i.e. rear section water pump.

e) When you have located "water pump rear", follow wiring until you come across C.B #56 and its circuit.

2. You have a problem with a specific system and you want to find the corresponding diagram.

**Problem:** The rear section speakers are inoperative and you must trace their electric circuit.

a) Refer to page A of main index and look for "Wiring diagram index", page L.

b) Refer to page L and look for the item corresponding to the defective system (in this case sound system, page 24).

c) You will find on page 24 the components as well as the electric wiring, thus providing you with a complete understanding of this circuit.

## Testing circuits

A careful study of the wiring diagrams should be made to determine the source and flow of current through each circuit. When a circuit is thoroughly understood, a point-to-point check can be made with the aid of the applicable wiring diagrams. Any circuit can be tested for continuity or short circuits with a multimeter or a suitable voltmeter.

All electrical connections must always be kept clean and adequately tight. Loose or corroded connections can result in discharged batteries, difficult starting, dim lights and improper functioning of other electric circuits. Inspect all wiring connections at regular intervals. Make sure knurled nuts on all amphenol-type plugs are securely tightened. Knurled nuts on the plastic amphenol-type connectors will click into a detent when properly tightened. Line connectors, which have the side locking tabs, must have the locks latched in place to ensure a proper electrical connection.

## Cleaning connectors with a Freon-base solvent

When the pins and sockets of connectors become dirty, clean them with a good quality solvent containing at least 90% Freon as its active ingredient. Freon has two qualities that recommend it. First, it does not conduct electricity and therefore, will not cause shorting between connector pins and sockets. Second, it evaporates quickly, eliminating the possibility of condensation within the connectors.

Always shake out or gently blow out any excess Freon before assembling a connector to its mating connector or hardware. Freon trapped in the connector can affect the connector seal.

**WARNING: Freon-based compounds should always be used in a naturally well-ventilated area, never in a confined space.**

## Circuit breakers

All electric circuits are protected by circuit breakers of the "Manual reset" type. The main circuit breakers, as well as those protecting the air conditioning system blower motors, are located in the third baggage compartment on R.H. side of the front section. The amperage rating of each breaker is given in figure 2.

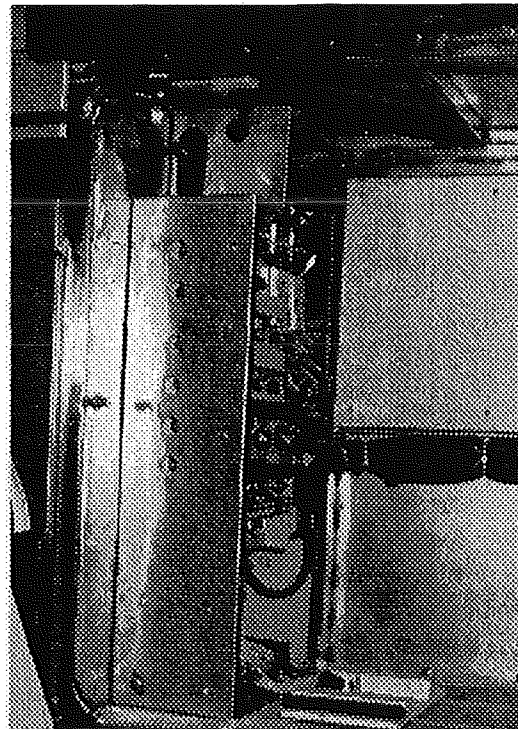

OPFIG17.JPG

- 1- Front junction box 70 amps - 12 volts
- 2- Articulation junction box 70 amps - 12 volts
- 3- Front junction box 90 amps - 24 volts
- 4- Rear junction box 70 amps - 24 volts
- 5- Front evaporator fan motors 90 amps - 24 volts
- 6- Rear evaporator fan motors 90 amps - 24 volts

**FIG. 2 - Breakers (from top to bottom)**

The smaller circuit breakers can be reached in all junction boxes. This type of circuit breaker deenergizes the circuit without disconnecting any wire. Simply press down the red button on breaker to open circuit, repair defective circuit, and afterwards depress black button in center of breaker to close circuit.

## Relays

Relays are used to automatically energize or deenergize a circuit from a remote location. The relay draws a very low current to energize its coil. Once the coil is energized, it develops a magnetic field which pulls a switch arm closed or open, to either energize or deenergize a given component. As the control current required for the coil is very low, the relay allows a remote station to control a high energy circuit without running great lengths of costly high capacity cable, and also eliminates the need for high amperage switches and heavy connectors.

Many systems on the H5-60 are provided with control relays, which are all located in the junction boxes.

**NOTE:** The magnetic relays for the engine run, starting motor and both evaporator motors (front and rear sections) should have the 5/16" stud nuts torqued to  $50 \pm 5$  Inch.lbs ( $5,6 \pm 0,5$  N.m).

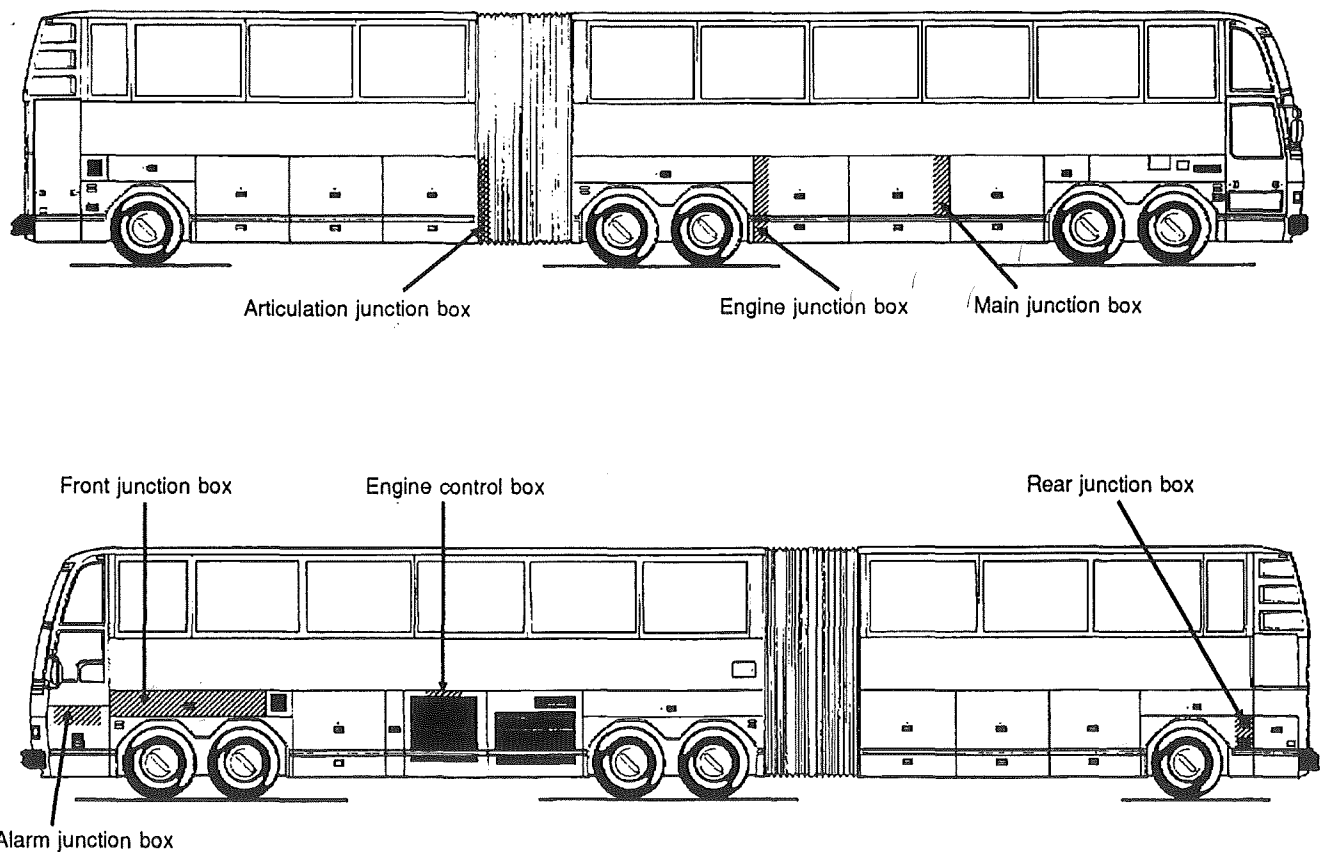

MA5-152A.IMG

### JUNCTION BOX LOCATIONS

## FRONT SERVICE COMPARTMENT

### Alarm junction box

The alarm junction box is located in the front service compartment, under the driver's window. To gain access, open the service compartment door (see fig. 3). This junction box contains the following items:

- Flasher unit
- Circuit breakers
- All alarm units
- ATEC test switch
- ATEC-DDEC DDL reader connector
- 110 volt connector
- 110 volt engine block heater switch

- 110 volt immersion heater switch for the lavatory fresh water reservoir

- 110 volt in-station lighting switch

Unscrew the 1/4 turn screws (2) and open the hinged panel to gain access to the following components located inside the alarm junction box (see fig. 4).

- The pulse generator for the intermittent mode of the upper windshield washer motor

- The 12 to 5 volt transformer for the back-up camera TV monitor

- The module for the dashboard brightness setting

- The junction terminals

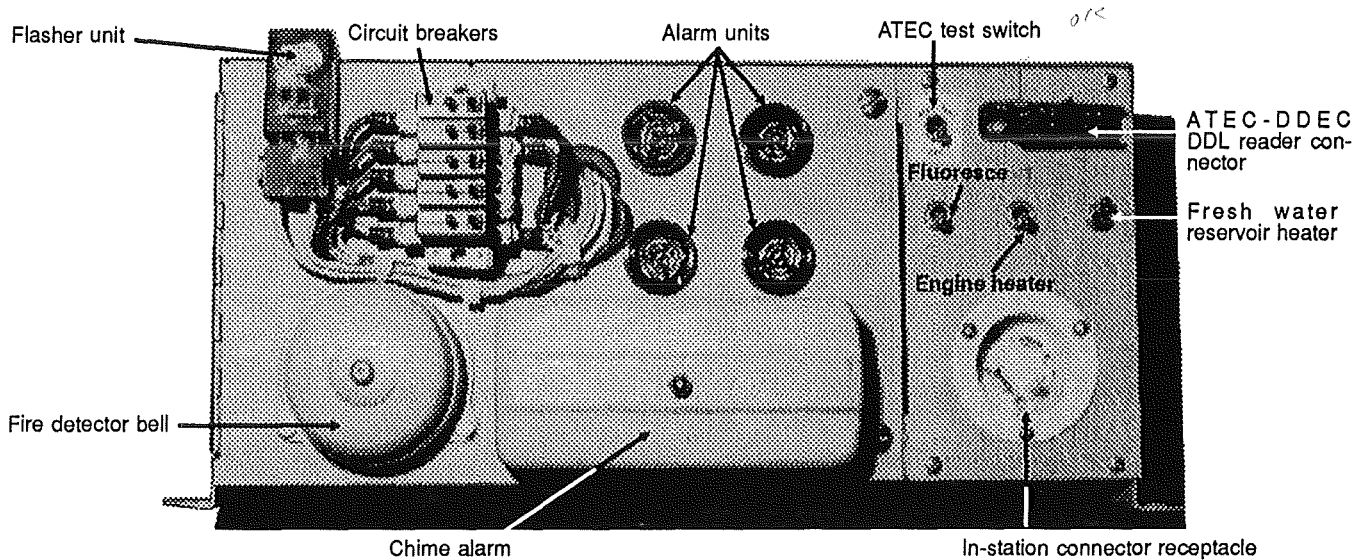

FIG. 3 - Alarm junction box

MA5-1503.IMG

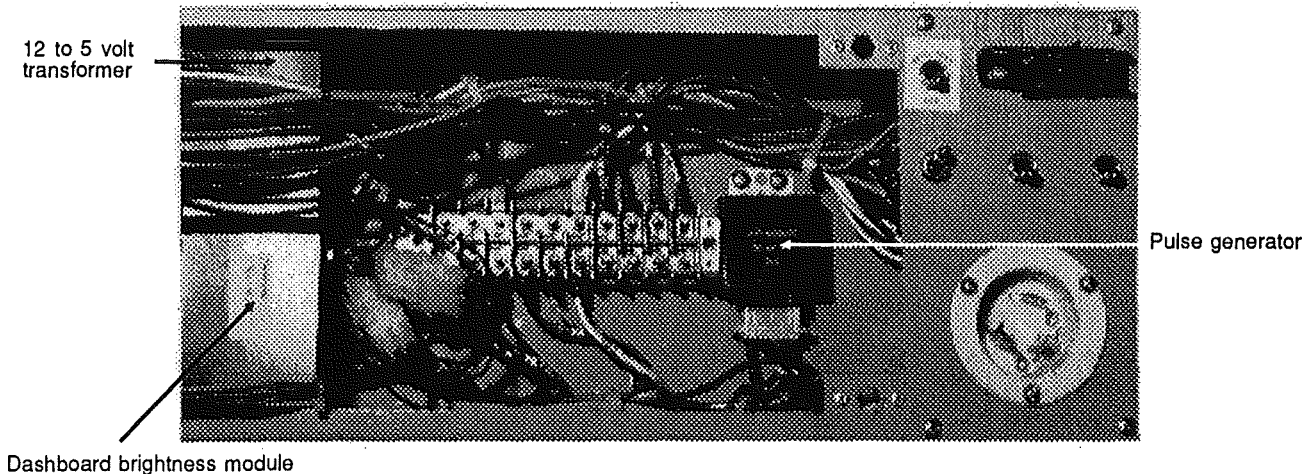

FIG. 4 - Alarm junction box (open)

MA5-1504.IMG

### Front junction box

The front junction box is located over the front axle on the left side of vehicle. The front of box is divided in two panels: the left panel includes cubic relays, one magnetic relay and some circuit breakers; the right panel consists of circuit breakers, diodes, and two paralleled resistors for the cornering lights. To gain access inside junction

box, unscrew the 1/4 turn screws (2). There are many spare terminals for connecting optional or additional accessories, as well as the speed switch for the rear door safety mechanism and for the articulation brake (see fig. 5).

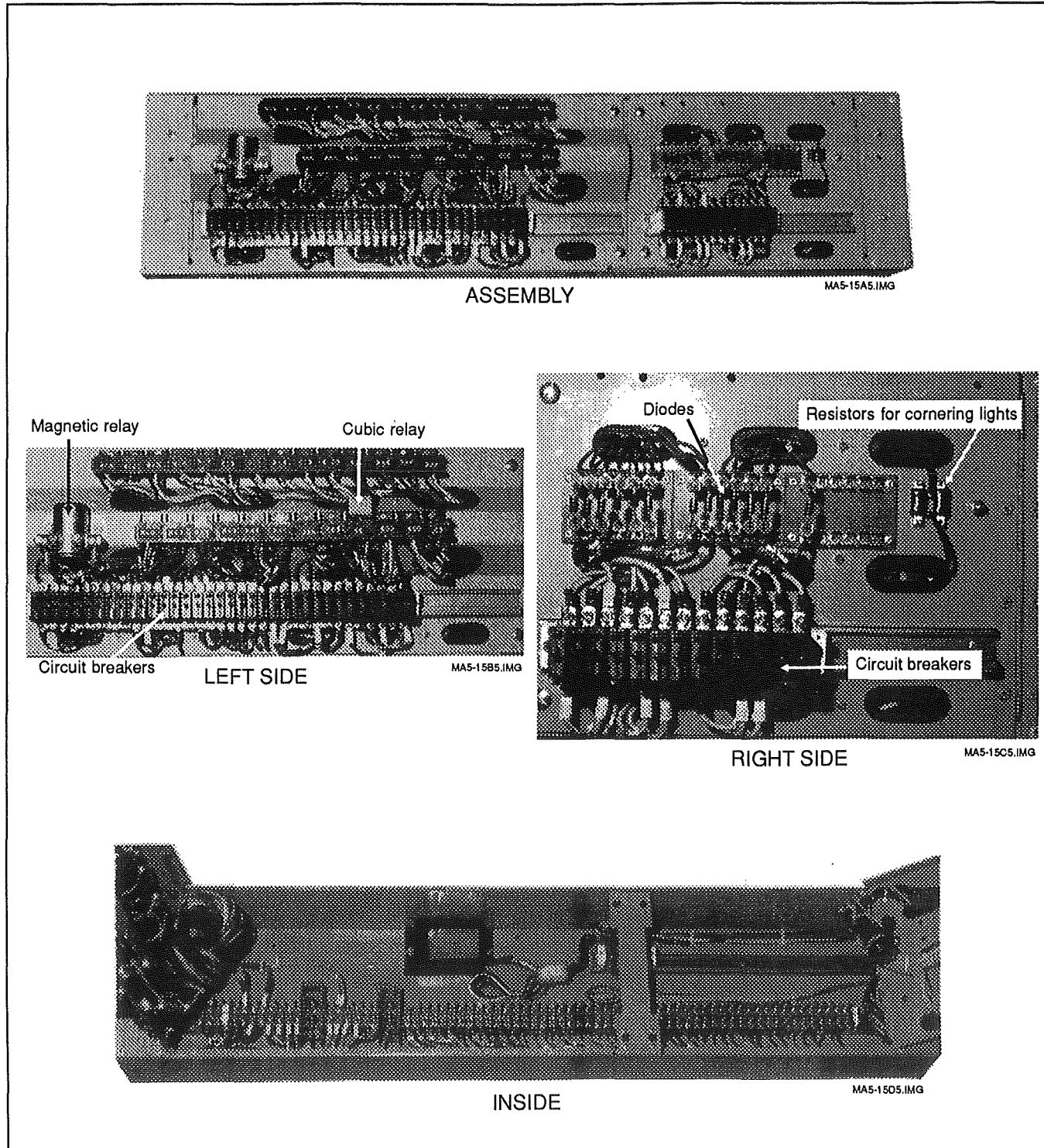

FIG. 5 - Front junction box

## Rear junction box

The rear junction box is located inside the lavatory reservoir service compartment on the left side of vehicle. To gain access to the box components, open the compartment door, unscrew the 1/4 turn screws (3) retaining the box panel, then remove panel to gain access to the following components:

- Junction terminals
  - 2 paralleled resistors for the left side docking light
  - 2 paralleled resistors for the right side docking light
- (see fig. 6)

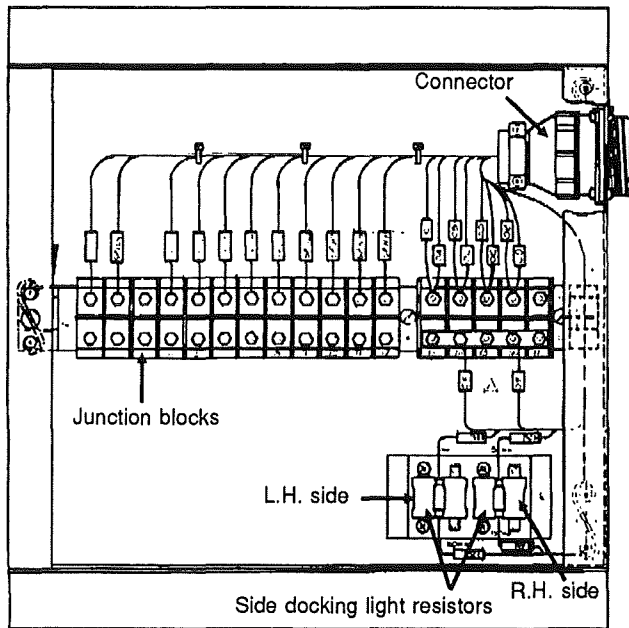

FIG. 6

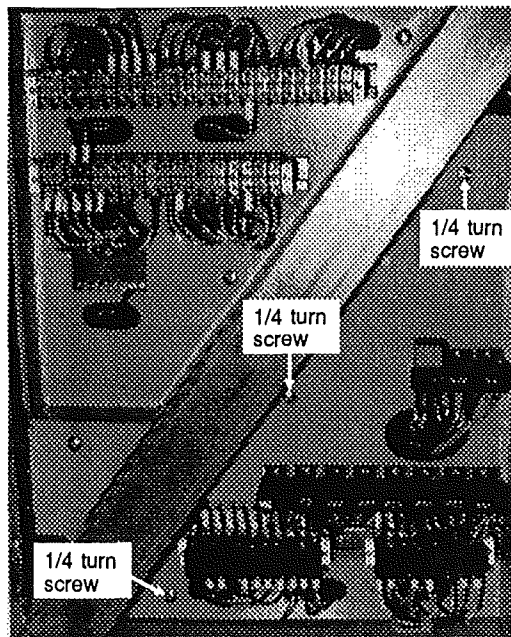

FIG. 7 - Articulation junction box

## Engine junction box

The engine junction box is so called, because it is located in the baggage compartment next to the engine, in front of the drive axles. To gain access, open baggage compartment door, remove the screws retaining the panel on side of box, and remove panel. The inside of junction box is divided in three sections. The upper section holds three magnetic relays, one for the starting motor solenoid feeding, and the other two for the feeding of the blower /evaporator motors (one for the front section unit and the other for the rear section unit). The center section contains the A/C-heating system light emitting diodes (LED), the printed circuit boards T7067B, the junction terminals, the DDEC-ATEC resistors, the diodes, the cubic relays and the breakers. Finally, the lower section contains the voltage regulator, the DDEC and ATEC modules.

To gain access to the components inside the engine junction box, unscrew the 1/4 turn screws (2) and open the hinged panel. The following components are located in this box: the junction terminals, the A/C and heating system control panel, the control modules (W973B), a junction battery terminal, junction boxes and the evaporator fan motor breakers (see fig. 8).

## Articulation junction box

The articulation junction box is located at the beginning of rear section on the right side of vehicle. To gain access, open the R.H. side rear section baggage compartment door located next to the articulation bellow, and unscrew the 1/4 turn screws (3) retaining panel. There are two hinged panels consisting of cubic relays, diodes, junction terminals, as well as breakers (see fig. 7). All these components control, energize, and protect the rear section accessories. Junction terminals are located behind these panels. To gain access, unscrew the turn screws (3) on each panel, and open the panels.

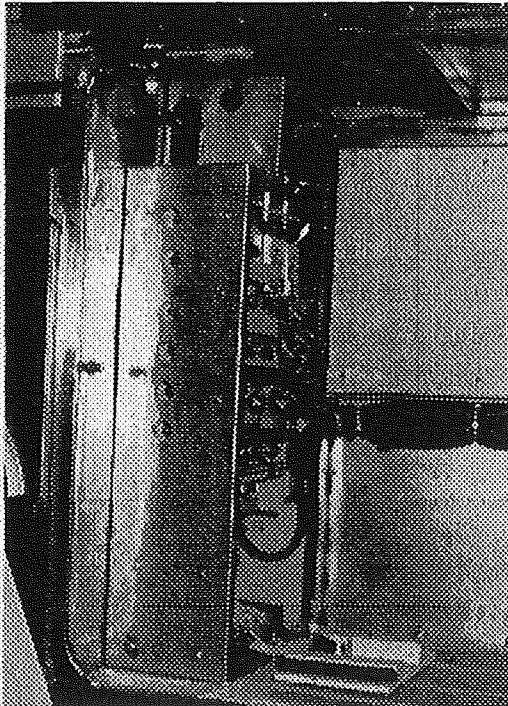

FIG. 8

OPFIG17.JPG

### Main junction box

The main junction box is located inside the second baggage compartment on the right side of vehicle, over the A/C compressor compartment (see fig. 9). Open baggage compartment door, unscrew the 1/4 turn screws (4), and remove panel to gain access to the following box components:

- two battery voltage equalizers (Vanner)
- 12 and 24 volt circuit breakers
- 12 volt main disconnect switch
- 24 volt main disconnect switch

### Engine control box

This control box is located in the engine compartment over the engine, and includes the engine remote control switch as well as the push button to start engine from compartment (see fig. 10).

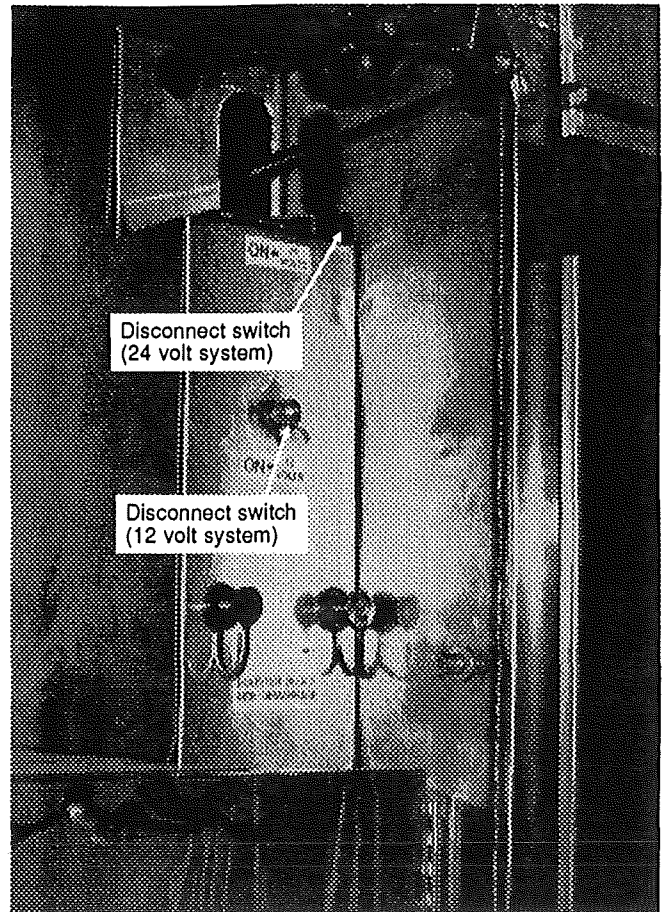

FIG. 9

OPFIG01.JPG

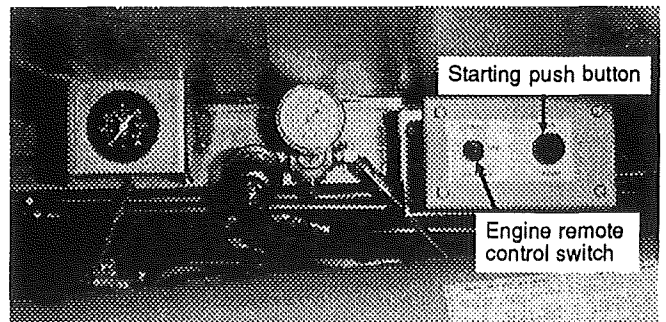

FIG. 10 - Engine control box

MA5-1510.JPG



## Main battery disconnect switches

Two main disconnect switches are provided for this vehicle: one for the 12 volt system and one for the 24 volt system. The two switches are located in the second R.H. side baggage compartment over the A/C compressor compartment. The 24 and 12 volt systems operating independently from each other, it is **necessary** to move the two disconnect switches to the "Off" position to deenergize both systems.

**NOTE:** When the main battery disconnect switches are turned to the "Off" position, all electrical supply from the batteries is cut off, with the exception of the tachometer clock, fire detectors, and radio programming memory.

To disconnect the batteries from the electrical system, slide the 24 volt disconnect switch lever forward to the "Off" position and rotate the 12 volt disconnect switch lever counterclockwise to the "Off" position.

Both battery main disconnect switch levers should be in the "Off" position before disconnecting cables from the batteries.

**CAUTION:** When the battery cables have been removed from the batteries, wrap the battery terminals and cable ends with electric tape to prevent accidental grounding. The ground cables should always be disconnected first and replaced last.

In replacing batteries, only batteries of the same specification should be used. Refer to "Specifications" at the end of this section for further details.

**CAUTION:** Ensure that connections are not reversed when reinstalling batteries, since damage to electrical system components will result.

When reinstalling batteries, battery connections must be torqued to 10-15 ft.lbs (13-20 N.m). A torque wrench is required to ensure an accurate tightening torque.

**WARNING:** To prevent possible electric shocks or sparking, the battery main switches must be set to the "Off" position before tightening an electrical connection.

A protective coating should be applied on all terminals that have been disconnected, and this coating should be clear of silicone. We recommend the use of "Clear Flex Guard" (68-0545) on all electrical connections of the coach.

## Battery general description

The vehicle is provided with four (4) *Maintenance-free* 12 volt "Heavy-Duty" batteries connected in series-parallel. The top mounted negative and positive terminals are tightly sealed to prevent leaks. Water never needs to be added to this type of battery. There are no filler caps in the cover. The battery is sealed, except for small vent holes in the cover. The vents must not be

restricted as they allow small amount of gasses that are produced in the battery to escape. The special chemical composition inside the battery reduces gassing to a very small amount at normal charging voltages. Besides reducing gassing, the special chemistry greatly reduces the possibility of overcharge damage.

The vents require keeping the battery in an upright position to prevent electrolyte leakage. Tipping the battery beyond a 45° angle in any direction can allow a small amount of electrolyte to leak out the vent holes.

**CAUTION:** *DO NOT* exceed this 45° angle when carrying or installing the battery.

Evidence of electrolyte leakage does not necessarily mean the battery is defective.

With special cables properly attached to batteries, the metal surfaces that carry the current are completely sealed from the atmosphere. This prevents terminal oxidation and corrosion that may cause starting and charging problems. If new cables are needed, sealed terminal cable replacements should be used to retain the reliability of the original maintenance-free connections.

**WARNING:** All lead-acid batteries generate hydrogen gas which is highly flammable. If ignited by a spark or flame, the gas may explode violently, causing spraying of acid, fragmentation of the battery, and possible severe personal injuries. Wear safety glasses when working near batteries. In case of contact with acid, flush immediately with water.

The battery has four (4) major functions which consist in:

1. Providing a source of current for starting the engine.
2. Stabilizing the voltage in the electrical system.
3. Supplying current for a limited time, when electrical demands of the equipment exceed the power output of the alternator.
4. Providing a limited source of power for connected accessories, when the engine is not running.

## Battery rating

Each of the 12 volt batteries has the following rating:

- Reserve capacity: 180 minutes
- Cold cranking (amps):
  - 625 @ 0 °F (-18 °C)
  - 490 @ -20 °F (-29 °C)
- Weight filled: 60 lbs (27,2 kg)

The reserve capacity is defined as the number of minutes a new, fully charged battery at 80 °F (26,6 °C) can be discharged at 25 amperes and maintain a minimum of 1.75 volts per cell (10.5 volts total for one 12 volt battery). This rating can be used as a basis for determining how long a vehicle might run after an alternator failure.

The cold cranking rating is defined as the minimum discharge current a battery will deliver in amperes for 30 seconds at 0 °F (-18 °C) while maintaining a minimum of 1.2 volts per cell (7.2 volts total for one 12 volt battery). This rating can be used as a basis for comparing starting performance.

## Battery installation

All batteries are mounted side by side in a sliding tray. The battery compartment, which is always locked, is located on the right side, over the second front axle. Ventilation is provided by two openings inside the compartment. To gain access, open the first R.H. side baggage compartment; pull and hold the lever in the upper R.H. corner, and with the other hand pull the compartment door, which will slide outwards (see fig. 11). To close, push in sliding tray completely, and the door will lock automatically.

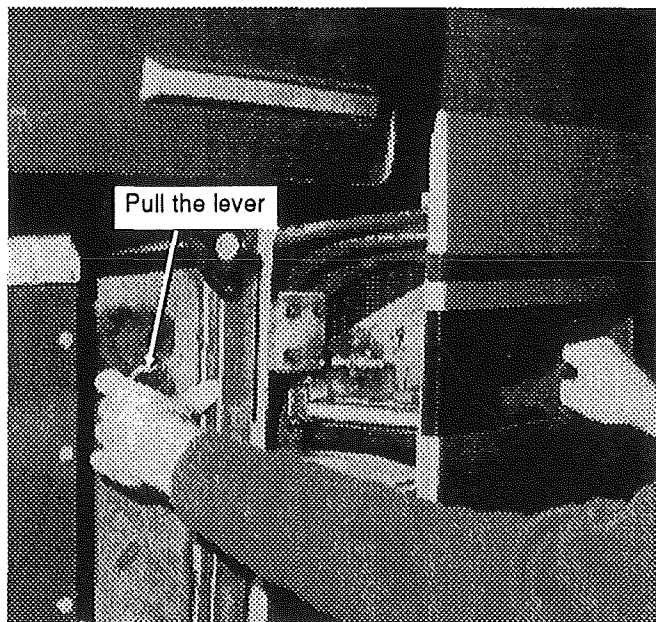

FIG. 11

OPFIG07.IMG

## Battery test indicator

The maintenance-free battery has a strong ability to withstand the damaging effects of overcharge. The test indicator in the cover is used only to determine if the battery can be tested in case of a cranking problem.

The test indicator in the battery cover is to be used with accepted diagnostic procedures only (see fig. 12). It must not be used to determine if the battery is good or bad, or charged or discharged. The test indicator is a built-in hydrometer in one cell which provides visual information for battery testing. Refer to the heading "Testing the maintenance-free battery" later in this section.

It is important when observing the test indicator, that the battery be relatively level and has a clean indicator top to see the correct indication. A light may be required in some poorly lit areas. Under normal operation, two indications can be observed.

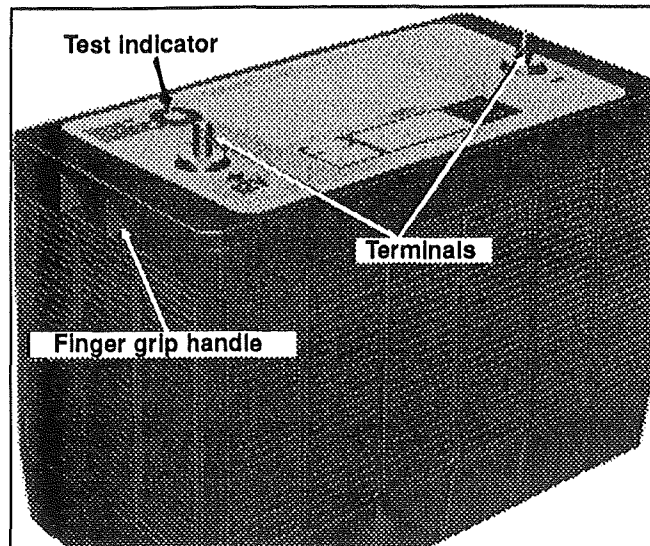

FIG. 12

MA5-1512.IMG

## Green dot visible

Any green appearance is interpreted as a "green dot", and the battery is ready for testing. On rare occasions, following prolonged cranking, the green dot may still be visible when the battery is obviously discharged. Should this occur, charge the battery as described under "Battery Charging Procedures" in "Battery maintenance" later in this section.

## Dark-green dot not visible

If a cranking complaint is encountered, the battery should be tested as described under "Testing maintenance-free battery" later in this section. On rare occasions, the test indicator may turn light yellow. In this case, the integral charging system should be checked. Normally, the battery is capable of further service; however, if a cranking complaint has been reported, replace the battery. **Do not charge, test, or jump-start.**

*1 DARK - GREEN DOT NOT VISIBLE...  
voir HS pour tests.*

## Testing maintenance-free battery

### Visual inspection

1. Check the outside of the battery for a broken or cracked cover or case that could permit loss of electrolyte. If obvious physical damage is noted, replace the battery.
2. Check for loose terminal posts, cable connections, damaged cables, and for evidence of corrosion; correct conditions as required before proceeding with tests (see fig. 13).

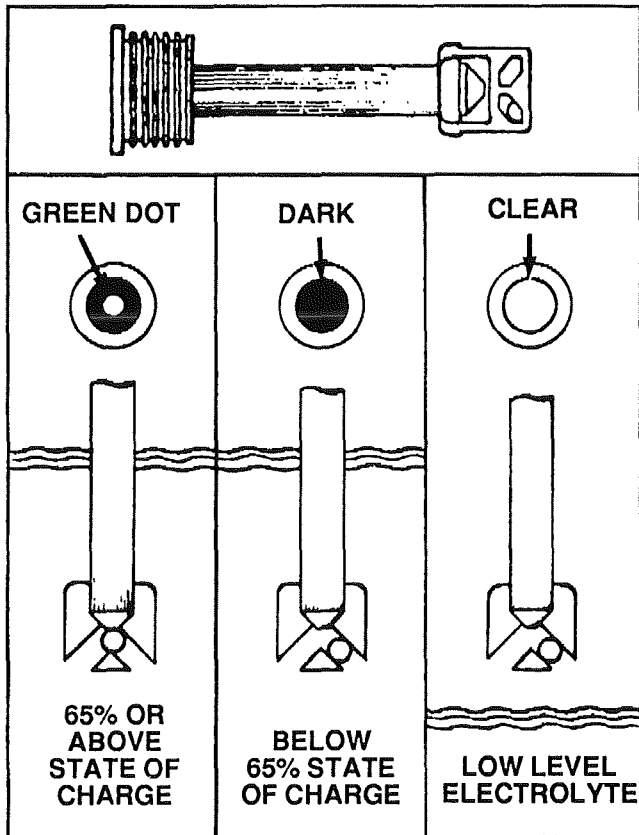

FIG. 13 - Hydrometer operation

### Test indicator

#### Green dot visible

If the indicator is dark and has a green dot in the center, the battery is ready for testing. Proceed with "Removing surface charge" as described later in this section.

**NOTE:** On rare occasions, such as after a prolonged cranking, the green dot may still be visible when the battery is obviously discharged. Should this occur, charge the battery as described under "Removing surface charge" hereafter.

*"BATTERY CHARGING PROCEDURE" later in this section*

### Removing surface charge

Disconnect cables from the battery and attach alligator clamps to the contact lead pad on the battery as shown in figure 16. Connect a 300 ampere load across the terminal for 15 seconds to remove surface charge from the battery.

### Load test

This test is one means of checking the battery to determine its ability to function as required in the vehicle.

To make this test, use test equipment that will take a heavy electrical load from the battery, such as a carbon pile resistor or other suitable means.

1. Connect a voltmeter, ammeter, and a variable load resistance as illustrated in figure 14.

**NOTE:** Observe polarity of the meters and the battery when making connections, and select the correct meter range.

2. Apply a 290 ampere load to the battery for 15 seconds.
3. With an ammeter reading specified load, read voltage. The voltage should be at least 9.6 volts. Disconnect the load.

If the voltmeter indicates 9.6 volts or more, the battery is good. If the voltmeter reading is less than 9.6 volts, replace the battery.

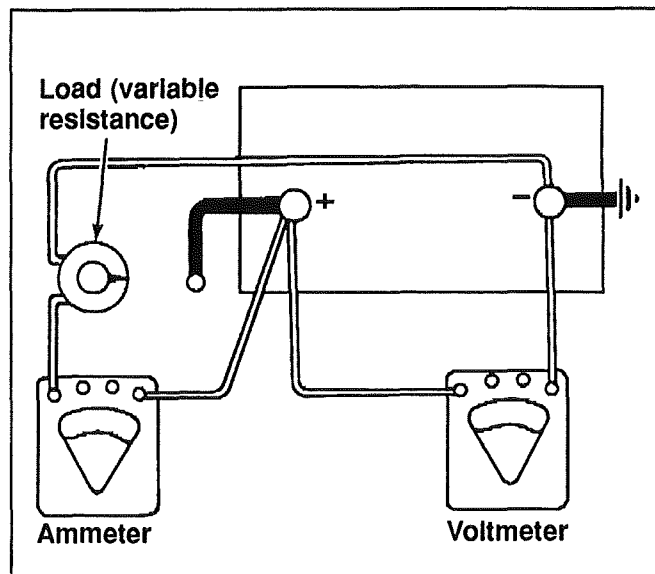

FIG. 14 - Connections for battery load test

This voltage is to be used for battery ambient temperatures of 70 °F (21 °C) and above. For temperatures below 70 °F (21 °C), refer to the following "Voltage and Temperature Chart" (see fig. 15).

**NOTE:** The accuracy of this test procedure is dependent upon close adherence to the proper load, time and temperature specifications.

## VOLTAGE AND TEMPERATURE CHART

Ambient Temperature	Minimum Voltage
70 °F (21 °C) and above . . . . .	9.6
60 °F (16°C) . . . . .	9.5
50 °F (10 °C) . . . . .	9.4
40 °F (4 °C) . . . . .	9.3
30 °F (-1 °C) . . . . .	9.1
20 °F (-7 °C) . . . . .	8.9
10 °F (-12 °C) . . . . .	8.7
0 °F (-18 °C) . . . . .	8.5

FIG. 15

### Battery precautions

During charging of the batteries, an explosive gas mixture forms in each cell. Part of this gas escapes through the vent holes and may form an explosive atmosphere around the battery itself if ventilation is poor. This explosive gas may remain in or around the battery for several hours after it has been charged. Sparks or flames can ignite this gas causing an internal explosion which may shatter the battery.

1. Do not smoke near a battery which is being charged or which has been recently charged.
2. Do not break live circuits at battery terminals because a spark usually occurs at the point where a live circuit is broken. Care must always be taken when connecting or disconnecting booster leads or cable clamps on chargers. Poor connections are a common cause of electric arcs which cause explosions.
3. The electrical system on this vehicle is **negative ground**. Installing the batteries with the positive terminals grounded or incorrect use of the booster battery and jumper cables will result in serious damage to the alternator, batteries and battery cables.

### Common causes of battery failure

When a battery fails, the cause of failure may be outside the battery. For this reason, when a battery failure is encountered, do not be satisfied with merely recharging or replacing battery. Locate and correct the cause of the failure to prevent recurrence. Some common external causes of battery failure are as follows:

1. Defect in charging system such as high resistance or a faulty alternator or regulator.
2. A malfunction within the 12 volt system (equalizers).
3. Overloads caused by a defective starter or excessive use of accessories.
4. Dirt and electrolyte on top of the batteries causing a constant drain.
5. Hardened battery plates, due to battery being in a low state of charge over a long period of time.
6. Shorted cells, loss of active material from plates.
7. Driving conditions or requirements under which the vehicle is used only for short drives.
8. A constant drain caused by a shorted circuit such as an exposed wire or water infiltration in junction boxes causing ground fault.
9. Extended operation of preheating system (Webasto) without engine running.
10. Omission of closing disconnect switches during overnight.

## BATTERY MAINTENANCE

### Cleaning and inspection

The external condition of the battery and the battery cables should be checked periodically. The top of the battery should be kept clean and the battery hold-down clamp bolts should be kept properly tightened. For best results when cleaning the battery, wash first with a diluted solution of ammonia or soda to neutralize any acid present, then wash out with clean water. The battery hold-down bolts should be kept tight enough to prevent the batteries from moving, but they should not be tightened to the point that excessive strain is placed on the battery hold-down cover.

To insure good contact, the battery cable ring terminals should be tight on the battery posts. If the posts or cable ring terminals are corroded, the cables should be disconnected and the posts and clamps cleaned separately with a soda solution and a wire brush. Install cable ring terminals on battery posts and tighten to a torque of 10-15 ft.lbs (13-20 N.m), then replace protective caps to prevent corrosion and sparks.

## Battery cables

Check all cable ring terminals and connections to determine if they are in good condition. Excessive resistance, generally caused by poor connections, produces an abnormal voltage drop which may lower voltage at the starting motor to such a low value that normal operation of the starting motor will not be obtained. An abnormal voltage drop can be detected with a low-reading voltmeter as follows:

**WARNING:** To prevent the engine from starting, the DDEC engine circuit, which is protected by a 5 amp breaker (CB-13) located in the engine junction box, must be deenergized during these tests; afterwards, depress black button to close circuit.

1. Check voltage drop between grounded (negative) battery terminal and vehicle frame by placing one prod of the voltmeter on the battery terminal and the other on a good ground (unpainted surface) on the vehicle. With the starting motor cranking the engine at a temperature of 70 °F (21,1 °C), voltage reading should be less than 0.3 volt. If the voltage reading exceeds 0.3 volt, there is excessive resistance in this circuit.

2. Check voltage drop between the positive battery terminal and the starting motor positive terminal stud while the motor is operated. If the reading is more than 2.5 volts, there is excessive resistance in this circuit.

**NOTE:** If it is necessary to extend the voltmeter lead for this test, use a #16 (AWG) or larger wire.

3. Check voltage drop between the starting motor housing and a good ground on the vehicle. The reading should be less than 0.2 volt.

**WARNING:** Any procedure other than the following could cause personal injuries or damages to the charging system resulting from battery explosion or electrical burns.

Wear adequate eye protection when working on or near the batteries. Ensure that metal tools or jumper cables do not contact the positive battery terminal (or a metal surface in contact with it) as a short circuit will result.

Do not attempt to jump start a vehicle suspected of having a frozen battery because the battery may rupture or explode.

Both the booster and discharged batteries must be treated carefully when using jumper cables. Follow exactly the procedure outlined later in this section, being careful not to cause sparks.

## Battery charging procedure

The batteries used on this vehicle can be charged either on or off the vehicle; however, when they are removed from the vehicle, it is recommended that an adapter kit, which is available from any A/C Delco dealer, be used in charging sealed-terminal batteries. Use the booster

block to charge the batteries when they are left on vehicle.

The alligator clamps of the tester or charger must be placed between the terminal nuts and the lead pads of the terminal studs (see fig. 16) after the vehicle cables are detached. The alligator clamps should make firm contact with the lead pads.

**NOTE:** If this connection cannot be made because of the alligator clip design, the load value for testing must be reduced from 290 to 260 amperes.

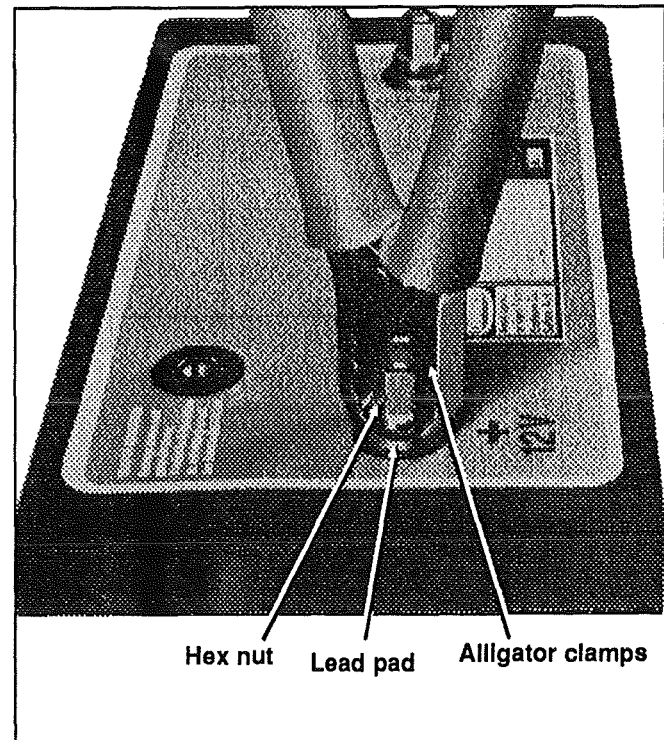

FIG. 16 - Testing and charging terminal adapter

On rare occasions, such as those that occur following prolonged cranking, the green dot in the test indicator may still be visible when the battery is obviously discharged. Should this occur, a boost charge of 20 ampere-hours is recommended. Under normal operating conditions, do not charge battery if the green dot is visible. The battery should never be charged if the test indicator (hydrometer) is clear or light yellow. If this occurs, replace the battery.

A charge rate between 3 and 50 amperes is generally satisfactory for any maintenance-free battery as long as spewing of electrolyte does not occur or the battery does not feel excessively hot (over 125 °F (52 °C)). If spewing or violent gassing of electrolyte occurs or battery temperature exceeds 125 °F (52 °C), the charging rate must be reduced or temporarily stopped to allow cooling and to avoid damaging to the battery.

Battery temperature can be estimated by touching or feeling the battery case. The battery is sufficiently charged when the green dot in the built-in hydrometer is visible. No further charging is required. Shake or tilt the

battery at hourly intervals during charging to mix the electrolyte and see if the green dot appears.

**CAUTION:** Always turn off the charger before connecting or disconnecting it to or from a battery.

**NOTE:** The charge rate must be doubled when the batteries are charged by the booster block, since we have a series-parallel circuit.

Battery charging consists of a charge current in amperes for a period of time in hours. Thus, a 25 ampere charging rate for 2 hours would be a 50 ampere-hour charge to the battery. Most batteries, whose load test values are greater than 200 amperes, will have the green dot visible after at least a 75 ampere-hour charge. In the event that the green dot does not appear, replace the battery.

## Battery charging guide

### Fast charging rate

20 amps @ 3 3/4 hours  
 30 amps @ 2 1/2 hours  
 40 amps @ 2 hours  
 50 amps @ 1 1/2 hours

### Slow charging rate

5 amps @ 15 hours  
 10 amps @ 7 1/2 hours

The time required for a charge will vary according to the following factors:

### Size of battery

For example, a completely discharged large heavy-duty battery requires more than twice the recharging time of a completely discharged small passenger car battery.

### Temperature

For example, a longer time will be needed to charge any battery at 0 °F/-18 °C than at 80 °F/26,6 °C. When a fast charger is connected to a cold battery, the current accepted by the battery will be very low at first, then in time, the battery will accept a higher rate as it warms.

### State of charge

For example, a completely discharged battery requires more than twice as much charge than a half-charged battery. Since the electrolyte is nearly pure water and a poor conductor in a completely discharged battery, the current accepted is very low at first. Later, as the charging current causes the electrolyte acid content to increase, the charging current will likewise increase.

## Charger capacity

For example, a charger which can supply only 5 amperes will require a much longer period of charging than a charger that can supply 30 amperes or more.

## Emergency jump starting with auxiliary (booster) battery

**WARNING:** Do not jump start coaches equipped with maintenance-free batteries if the test indicator is light yellow.

Both booster and discharged batteries should be treated carefully when using jumper cables. A vehicle with a discharged battery may be started by using energy from a booster battery or the battery from another vehicle.

**WARNING:** Jump starting may be dangerous and should be attempted only if the following conditions are met.

1. The booster battery or the battery in the other vehicle must be of the same voltage than the battery in the vehicle being started, and must be negative grounded.
2. If the booster battery is a sealed-type battery without filler openings or caps, its test indicator must be dark or a green dot must be visible. Do not attempt jump starting if the test indicator of the booster battery or the discharged battery has a light or bright center.

**WARNING:** Follow exactly the procedure outlined hereafter, being careful not to cause sparks.

1. Wear eye protection and remove rings, watches with metal bands and other metal jewelry.
2. Apply parking brake and place the transmission shift lever or push-button pads in Neutral (N) position in both vehicles. Turn off lights, heater and other electrical loads. Observe the charge indicator. If the indicator in the discharged battery is light, replace the battery. **Do not** attempt jump starting when indicator is light. If the test indicator is dark and has a green dot in the center, failure to start is not due to a discharged battery and the cranking system should be checked. If charge indicator is dark but the green dot does not appear in center, proceed as follows:
3. Connect one end of one red jumper cable to the positive (+) terminal of the booster power source and the other end to the positive (+) terminal of the booster power block, located in second R.H. side baggage compartment of the front section (see fig. 17).
4. Connect one end of the remaining negative jumper cable (black) to the negative (-) terminal of the booster power source, and the other end of the black jumper cable to the negative (-) terminal of the booster power block.
5. Take care that the clips from one cable do not inadvertently touch the clips on the other cable. Do not lean over the battery when making connections. The ground

connection must provide good electrical conductivity and current carrying capacity.

6. Start the engine in the vehicle that is providing the jump start. Let the engine run for a few minutes, then start the engine in the vehicle that has the discharged batteries.

7. When removing the jumper cables, perform the above procedure exactly in reverse order, and replace protective caps on booster block terminals.

**WARNING:** Any procedure other than the above could result in personal injury, property damage due to battery explosion, or damage to the charging system of the booster vehicle or of the boosted vehicle.

**NOTE:** Jumper cables must withstand 500 cranking amperes. If cable length is 20 feet (6 m) or less, use 2/0 (AWG) gauge wires. If cable length is between 20-30 feet (6-9 m), use 3/0 (AWG) wires.

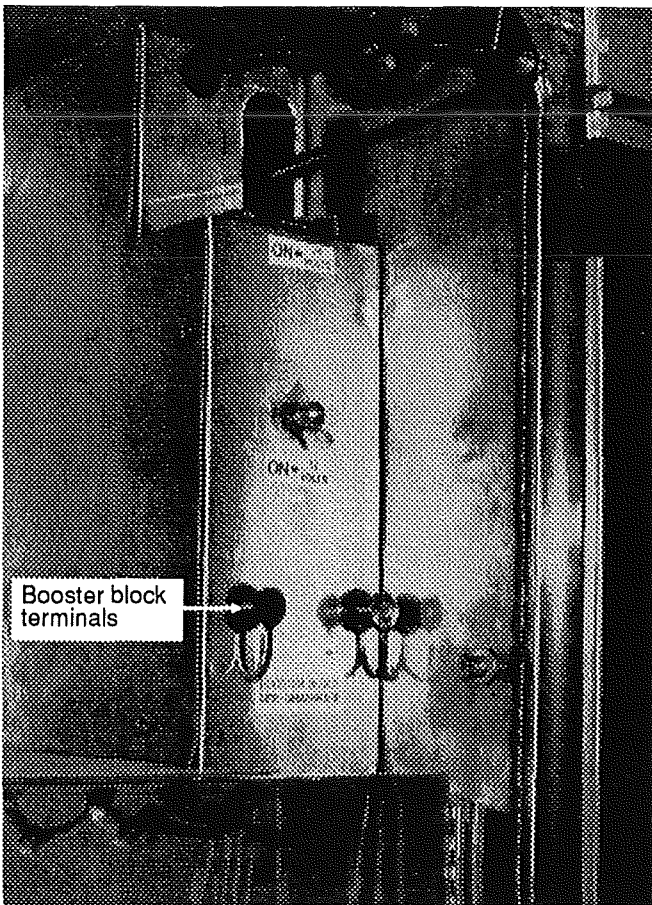

FIG. 17

OPFIG01.IMG

## Troubleshooting

If a battery has tested good and then has not performed satisfactorily in service for no apparent reason, the following factors may point to the cause of trouble:

1. Vehicle accessories and disconnect switches inadvertently left on overnight.
2. Defects in the charging system, such as high wiring resistance, faulty alternator or regulator.
3. A vehicle electrical load exceeding the alternator capacity, with the addition of electrical devices, such as CB radio equipment, a cellular phone or additional light system.
4. Defects in the electrical system, such as shorted or pinched wires.
5. Extended slow speed driving with many accessories turned on.
6. Loose or poor battery cable-to-post connections, previous improper charging of a run-down battery, or loose hold-down clamp bolts.
7. High-resistance connections or defects in the cranking system.

## GEAR DRIVEN OIL-COOLED ALTERNATOR

The 24 volt charging system consists of a gear driven, oil-cooled, brushless alternator, a 24 volt voltage regulator, an alternator relay and a 12 volt system that includes two (2) 12 volt, 50 amp equalizers. The components used in this system are described under the applicable headings hereafter.

This oil-cooled alternator is of the self-rectifying type in which all current carrying members, windings, built-in diodes, and field coils are stationary. The only moving component is the rotor. The alternator is a totally enclosed unit, cooled and lubricated by engine oil. The oil inlet is on the diode end cover. The oil drains back into the engine crankcase through the drive end frame and drive adapter housing (see fig. 18 and 19). The alternator should never be operated with the oil supply line disconnected. A continuous flow of engine oil flows through the alternator to lubricate the bearings and cool the assembly.

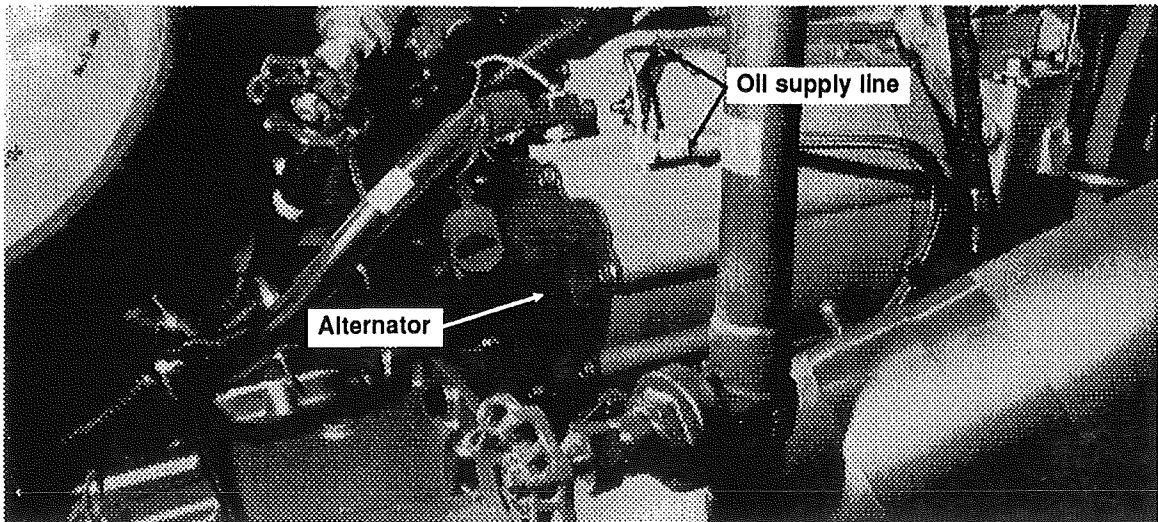

FIG. 18 - Alternator Installation

MA5-1518.IMG

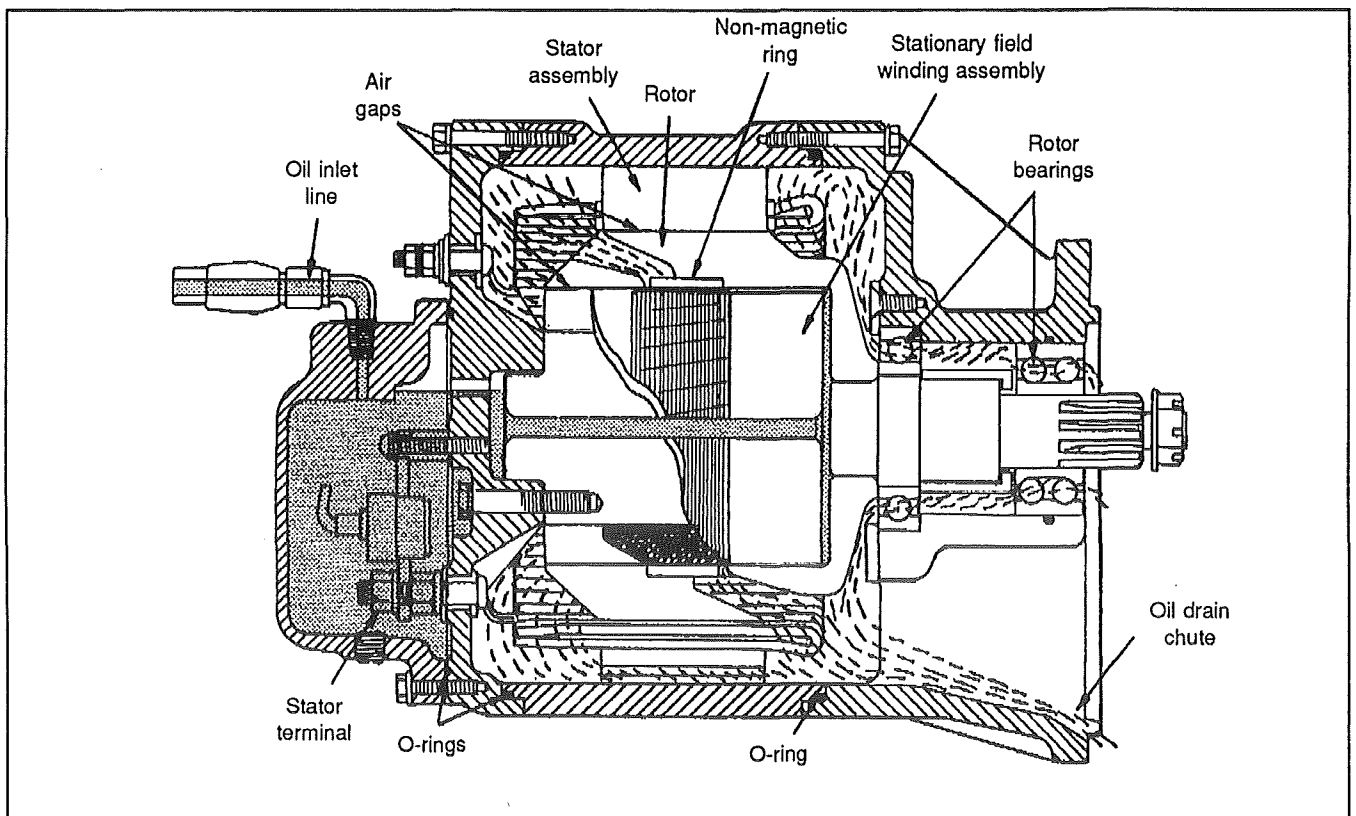

FIG. 19 - Oil circulation through alternator

MA5-1519.IMG



Four terminals are used on this alternator: the DC output terminal, two field terminals, and a relay terminal. The alternator output voltage is regulated by a separate 24 volt regulator that controls the alternator field current (see fig. 20).

**CAUTION:** The electrical system is *Negative ground*. Connecting the batteries or a battery charger with the positive terminal grounded will endanger the alternator diodes and vehicle wiring by high current flow. Burned wiring harness and burned "open" diodes will result. Always ensure that the alternator and battery polarities are matched prior to installation. *The alternator will not reverse to accept inverse polarity.* Also, do not ground or short across any of the alternator or regulator terminals.

Since there are no brushes, slip rings, or rubbing seals, the alternator requires no periodic maintenance other than the following:

1. Check alternator-to-engine mounting bolts for looseness and tighten to the proper torque.
2. Check all electrical connections for tightness and corrosion. Clean and tighten connections as necessary. Be sure wiring insulation is in good condition and that all wiring is securely clipped to prevent chafing the insulation.

3. With the engine running, listen for noise and check the alternator for vibration. If the alternator is noisy or vibrates excessively, it should be removed for inspection and repair.

4. Ensure that battery terminals are clean and tight.

## Alternator on-vehicle checks

Abnormal operation of the alternator, the 24 volt regulator, and the 12 volt equalizers is indicated by a 12 and a 24 volt voltmeters located on the L.H. dashboard control panel. Normally, the voltmeters will indicate a charge condition when the engine is started and the alternator is charging. If the voltmeters do not indicate a charging condition during operation, or if the "Battery" warning light illuminates, trouble is indicated in the alternator, the 24 volt regulator, or the 12 volt equalizers.

The most common problems encountered within the alternator are:

- Open or shorted alternator diodes.
- Open, shorted, or grounded stator winding.
- Open, shorted, or grounded field winding.
- Excessive alternator noise.

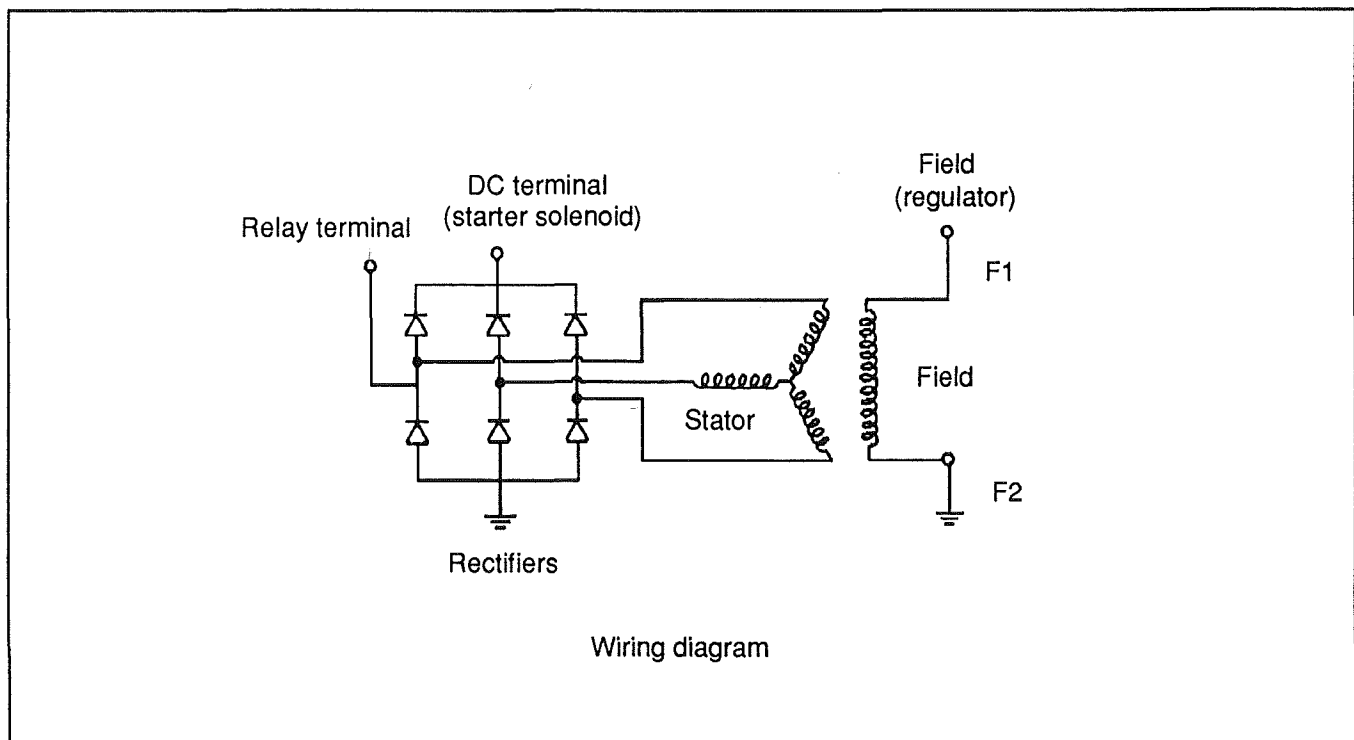

FIG. 20 - Alternator schematic diagram

MA5-1520.IMG

## Diagnosis of charging system problems

Condition of the charging system is monitored by a 12 and a 24 volt voltmeters located on the L.H. dashboard control panel. The most common problems encountered within the charging system are:

- The 12 and 24 volt voltmeters indicate a normal charge and the "Battery" warning light is illuminated
- The 12 and 24 volt voltmeters indicate a low charge, or the batteries are in a low state of charge
- The 12 volt voltmeter indicates a low charge and the 24 volt voltmeter indicates a normal charge
- The 12 and 24 volt voltmeters indicate an overvoltage

### 12 and 24 volt voltmeters indicate a normal charge and the "Battery" warning light is illuminated

This is an indication that the trouble is located in the blower cut-in relay or in a defective connection within the circuit. Current is supplied to the operating coil of the blower cut-in relay terminal #86 from the "R" terminal of the alternator when the engine is running and the alternator is charging. To check if it is the blower cut-in relay or defective connection, proceed as follows:

1. Connect a voltmeter lead to terminal #86 on the relay and to ground on the coach.
2. Start the engine and note voltmeter reading. A reading between 12 and 14 volts is normal, and indicates there is an adequate feed to energize the relay. Following this test, you know that the problem is not located in a defective connection but in a defective blower cut-in relay. If there is no reading, proceed with step 3 to

determine which of the connection or the alternator is defective.

3. Connect voltmeter leads to the alternator relay terminal and to ground on the coach. The voltmeter should read between 12 and 14 volts when the alternator is charging. No voltage indicates a problem with the alternator or regulator. If reading is between 12 and 14 volts at the "R" terminal, and there is no voltage at terminal #86 of the blower "Cut-in relay", the problem is in the connections between both terminals. Refer to "Engine control" wiring diagram in "Wiring diagrams" page 1/24 for electric circuits and connections.

### 12 and 24 volt voltmeters indicate a low charge

This is an indication that the problem is in the wiring, the 24 volt regulator, or the alternator. To determine which unit is faulty, proceed as follows:

1. Start the engine and momentarily connect a jumper from the "F1" field terminal to "DC (+)" terminal. For connections, refer to figure 21.

**CAUTION: Do not feed the alternator field "F1" terminal for more than 10 seconds. High voltage could burn out the wires and components of charging system, and seriously damage the alternator.**

**Do not jump the "F2 (-)" terminal with the "DC (+)" terminal on the alternator. This will result in a direct short circuit.**

- a) If the voltmeter readings increase, trouble is located in the 24 volt regulator or wiring. Check the regulator as explained under "Voltage regulator" later in this section.
- b) If the voltmeter readings do not increase, the problem may be in the alternator.

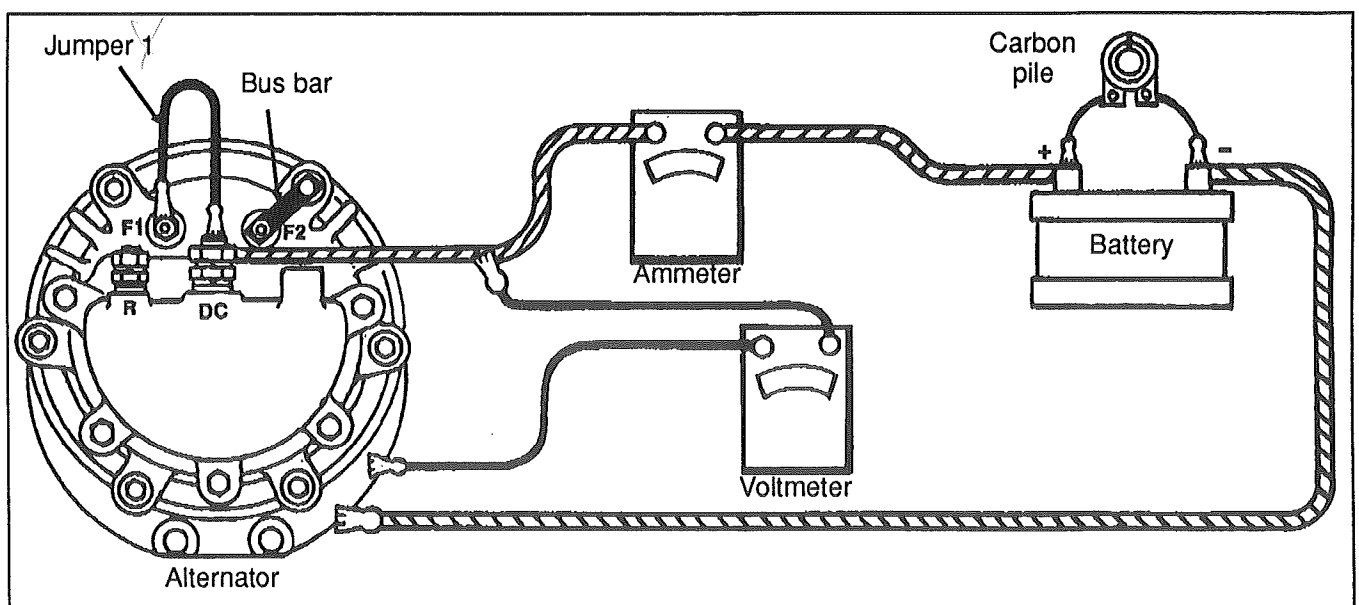

FIG. 21 - Connections for checking alternator output

MAS-1521.IMG

### **12 volt voltmeter indicates a low charge and the 24 volt voltmeter indicates a normal charge**

This is an indication that the trouble is in the 12 volt equalizers or in their wiring.

**NOTE: The 12 volt equalizers are equipped with a manual reset-type circuit breaker; push down the reset button to reset the circuit breaker.**

For further information about the equalizers, refer to "Equalizer troubleshooting" later in this section.

### **12 and 24 volt voltmeter indicate an overvoltage**

This is an indication that the problem is in the voltage regulator.

Refer to "Voltage regulator" later in this section.

## **Alternator diagnosis**

**CAUTION: Before checking the alternator, TURN OFF the battery main disconnect switches.**

It is not necessary to disassemble completely the alternator to make electrical checks. All electrical checks are made at the diode end of the assembly without having to remove the rotor, drive end frame, or bearing. If the electrical components are not defective, but bearing replacement is necessary, this can be done at the drive end without having to disassemble the diode end of the unit.

The components in the alternator which require electrical checks are the field winding, the six diodes, and the stator winding.

### **Diode checks**

Before proceeding with diode checks, the following procedure must be performed to remove the diode end cover.

1. Ensure the battery main disconnect switches are disconnected.
2. Remove the pipe plug from underneath the end housing to drain the oil in the rectifier engine oil supply.
3. Remove the cap screws (7) and lock washers which attach the diode end cover to the end housing. Remove the end cover from the end housing.

**NOTE: Do not operate the alternator unless this unit is completely reassembled.**

4. Remove seal from the end housing, detach and remove "DC" and relay terminals, stud, insulating sleeves and O-rings.

5. Disconnect all diode flexible leads, i.e. three from the output terminal stud and three from the diode supports. See figure 22 for more details.

Each diode may be checked for shorts and opens with an ohmmeter.

**NOTE: The ohmmeter polarity may be determined by connecting its leads to voltmeter leads. The voltmeter will read up-scale when the negative leads are connected together and the positive leads are connected together. The polarity of the voltmeter leads may be determined by connecting the leads to the identified terminals on a battery.**

### **Diode checks (negative ground alternator)**

**NOTE: Use an ohmmeter with a single 1.5 volt cell. Most accurate reading will be determined when the 300 ohm value is calibrated to the center one-third of the scale. Do not use high voltage, such as a 110 volt test lamp to check diodes.**

### **Diodes mounted in supports**

To check diodes mounted in the supports for shorts or opens, connect the positive ohmmeter lead to each diode lead and the ohmmeter negative lead to each support as shown in "A", "B", and "C" of figure 23. Note the reading, then reverse the ohmmeter lead connections, and note again the reading. The ohmmeter readings may vary considerably when checking diodes for shorts, but if both readings are less or greater than 300 ohms, the diode is likely defective and should be replaced. Replace defective diodes as explained later in this section.

**NOTE: A good diode will give one very low and one very high reading.**

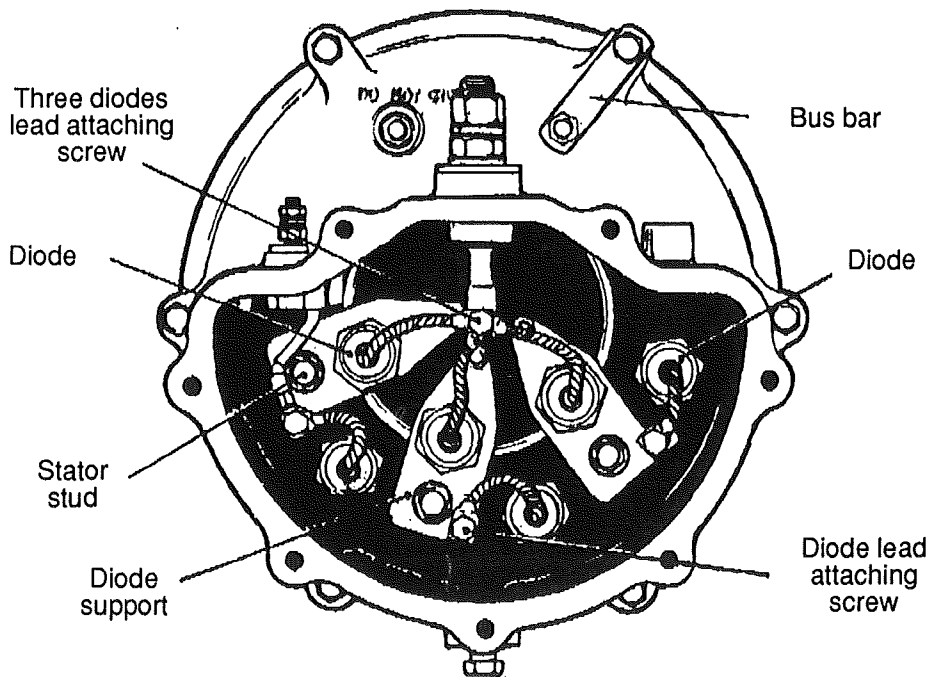

FIG. 22 - View of rectifier end frame with cover removed

MA5-1522.IMG

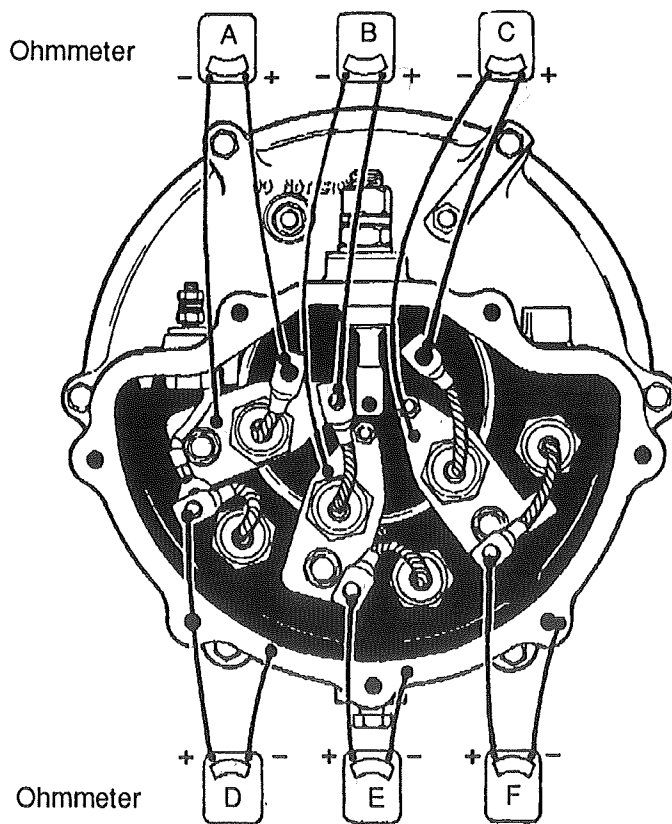

FIG. 23 - Checking diodes with ohmmeter on a typical oil-cooled alternator (end cover removed)

MA5-1523.IMG

## Diodes mounted in end frame

To check diodes mounted in the end frame for shorts or opens, connect the ohmmeter negative lead to each diode lead and the ohmmeter positive lead to the end frame as shown in "D", "E", and "F" of figure 24. Note the reading, then reverse the ohmmeter lead connections and note the reading. The diode is defective if both readings are less or greater than 300 ohms. Diodes can be replaced by following the procedure outlined under the headings "Disassembly" and "Reassembly".

**NOTE: A good diode will give one very low and one very high reading.**

When reinstalling diodes, torque to 9-11 ft.lbs (12-15 N.m). Re-stake next to the threads in an arbor press with an 1/8 inch (3,2 mm) round punch. Press the punch with gradual pressure; do not strike as the shock may damage the diodes.

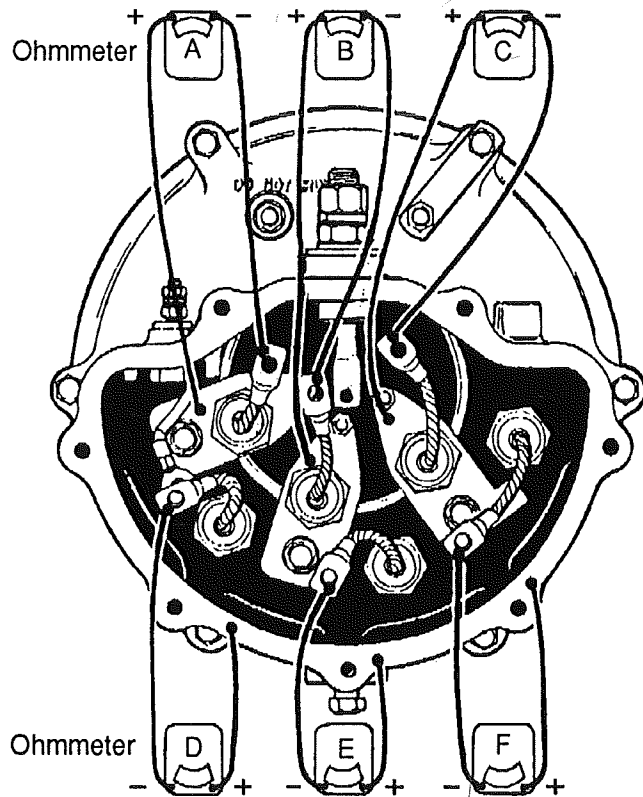

MA5-1524.IMG

FIG. 24 - Checking diodes with ohmmeter on a typical oil cooled alternator (end cover removed)

## Field winding

The field winding may be checked for shorts and opens with an ohmmeter. To check the field winding, connect the ohmmeter to field terminal and to ground. A resistance reading above normal indicates an open, and a reading less than normal indicates a short. The normal resistance value is 3.0 to 3.3 ohms at 80 °F (27 °C). An alternate method of checking is to place a battery of

specified voltage, and an ammeter in series with the field winding. The current should register 7.2 to 8.3 amperes at 24 volts. Coil resistance is approximately 3.1 ohms. Amperage readings, other than the above, indicate an open, grounded, or shorted field. A defective field coil can be replaced by removing the end frame on which the field terminal is located and then removing the four field coil mounting screws. See the headings "Disassembly" and "Reassembly" for a detailed procedure.

## Stator winding

The stator winding may be checked for opens and shorts with an ohmmeter as follows:

### Opens

Connect the ohmmeter leads to two pairs of diode supports as shown in parts "A", "B", and "C" of figure 25. Polarity of the leads must be observed. The ohmmeter should indicate a low resistance. If an infinite or a high resistance is measured in either one or both checks, the stator windings are open.

### Grounds

To check the stator windings for grounds, connect an ohmmeter to the diode support and diode end frame as shown in view C of figure 25. The ohmmeter should indicate a very high or infinite resistance. If zero, or a very low resistance is measured, the windings are grounded.

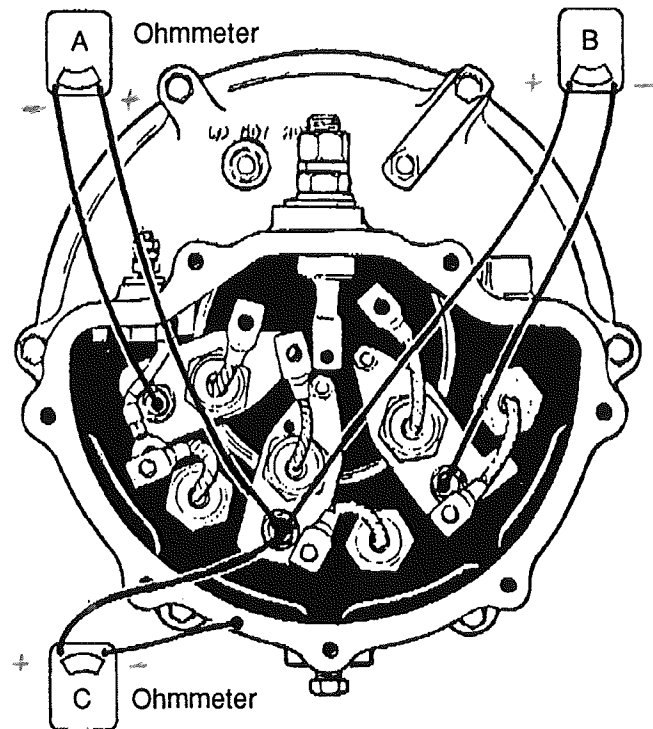

MA5-1525.IMG

FIG. 25 - Checking stator windings for "Opens" and "Grounds"

## Shorts

The stator windings are difficult to check for shorts without finely calibrated laboratory test equipment due to the very low resistance values of the windings. However, if all other alternator checks are satisfactory, yet the unit fails to perform to specifications, shorted stator windings are likely.

## Diode replacement

The following replacement procedures are based on the assumption that the diode end cover is still removed and diode leads were disconnected as explained earlier in this section.

**NOTE: When replacing a diode, make sure it is designed for a negative ground system. The diode can be identified by the symbol stamped on the diode case. The arrow must point toward the diode flexible lead.**

To replace the three diodes which are mounted in the supports attached to the stator lead studs, it is necessary to remove the diode and support assembly. The two outer diode and support assemblies are identical and can be installed on either side. The center unit has a different support, with 2 inches (50,8 mm) between the mounting hole centers.

**NOTE: The outer supports are provided with 2 1/4" (57,15 mm) center holes.**

## Diode (in support) replacement

1. Remove nut with lock washer attaching the diode support to the stator lead stud.
2. Remove nut, lock washer, and flat washer attaching support to the small stud in the end frame.
3. Remove the diode and support assembly, then remove insert from small hole in support or from small stud in the end frame.
4. Remove nut and flat washer from diode mounting stud, then remove diode from the support.
5. Place a new diode in the support and install a flat washer and nut on the diode mounting stud. Hold the diode with a wrench placed over flats on the diode, while tightening nut on the mounting stud to a torque of 160-180 inch.pounds (17-20 N.m).
6. Place diode and support assembly over the stator lead stud and the small mounting stud. Place insert over small stud inside the hole in the support. Install flat washer, lock washer, and nut on the small stud, and tighten to a torque of 22-25 inch.pounds(2-3 N.m). Install nut with lock washer on stator lead stud and tighten firmly.

## Diode (in end frame) replacement

To remove diode, use a thin 1 inch open end wrench on flats of the diode case to unscrew diode from the end frame. Thread the new diode into the end frame and tighten to a torque of 160-180 inch.pounds (17-20 N.m). If no other parts are to be replaced, refer to "Diode end cover installation" later in this section.

## Field replacement

### Removal

1. Remove three diode and support assemblies from the end frame to provide access to the two lower field to end frame bolts.
2. Remove nut with lock washer and flat washer from three stator lead studs.
3. Remove the six (6) bolts and lock washers attaching the diode end frame to the stator frame.
4. Separate the end frame from the stator frame, and remove the end frame and field assembly from the rotor while pushing the stator lead studs out of the end frame.
5. Remove nut, lock washer, flat washer, and insulating washer which secure the field lead terminal stud in the end frame. Push the stud out of the end frame.
6. Remove field terminal stud insulating bushing and seal from the end frame. Remove insulating sleeve from the field terminal stud.
7. Remove the four bolts and lock washers attaching the field to the end frame.
8. To separate the field from the end frame, install four 3/8-24 X 3 inch bolts in place of the 3/8-24 X 2 inch bolts removed in step 7. Thread bolts in to equal heights. Support the end frame in an arbor press, then using a suitable press plate to exert pressure on all four bolt heads, press the field out of the end frame.

### Installation

1. Position the field assembly on the end frame, insert four 3/8-24 X 3 inch bolts through the end frame and thread into the field to keep holes aligned.
2. Support the end frame on an arbor press bed in such a manner that the diodes will not be damaged, and press the field into the end frame. Press in until shoulder on field coil bottoms against the end frame.
3. Remove the four guide bolts. Install four 3/8-24 X 2 inch bolts, using new lock washers to attach the field to the end frame. Tighten bolts securely.

4. Place insulating sleeve in inner side of the field terminal stud hole in the end frame, and insert the terminal stud through the sleeve. Place two O-rings and insulating bushing over the terminal stud and push into hole in the end frame. Install insulating washer, flat washer, toothed lock washer, and nut on terminal stud and tighten firmly.

5. Install each stator lead stud in the end frame as follows: Place insulating washer over the stud and insert the stud through the end frame. Place the insulating bushing over the stud and position in end frame hole. Install flat washer, lockwasher, and nut on the stud, and tighten firmly.

6. Install three diode and support assemblies on the end frame as previously directed under "*Diode replacement*".

7. Install a new seal in notch around end of the stator frame. Insert field into the rotor and position the end frame against the stator frame. Attach end frame to the stator frame with six bolts and lock washers. Tighten bolts firmly.

8. If no other parts require replacement, refer to "*Diode end cover installation*" later in this section to complete the assembly.

## Stator replacement

If tests performed under "*Stator winding checks*" earlier in this section indicated an open circuit or short in the stator, the stator and frame assembly must be replaced.

## Removal

1. Remove diode end frame and field assembly as previously directed in Steps 1 through 4 under "*Removal*" in "*Field replacement*" procedure.

2. Remove the six (6) bolts and lock washers attaching the stator frame to the drive end frame.

3. Separate the stator frame from the drive end frame and remove the stator frame from the end frame and rotor.

## Soldering stator terminal leads

1. Using a wire brush, thoroughly clean the wire and terminal.

2. Silver solder the stator lead to the terminal using a torch.

3. Thoroughly clean the silver solder connection with a wire brush.

4. Using a high grade energized rosin flux, coat the silver soldered connection with an 80-20 tin-lead solder or pure tin solder to prevent deterioration of the silver solder by engine oil.

**NOTE: The silver solder will provide the required mechanical strength which will not be affected by temperature. The tin-lead solder will protect the silver solder connection from deterioration by engine oil.**

## Installation

1. Position new seal in notch around the drive end of the stator frame.

2. Position the stator and frame assembly over the rotor against the drive end frame. Attach the stator frame to the drive end frame with six bolts and lock washers. Tighten bolts firmly.

3. Install diode end frame and field assembly as directed in Steps 5, 6 and 7 under "*Installation*" in "*Field replacement*" procedure.

4. Install rectifier end cover as directed later.

## DIODE END COVER INSTALLATION

1. Make sure all diodes are properly installed and securely tightened. Leads from diodes threaded into the end frame must be securely attached to the diode supports. The relay terminal lead must also be attached to the left diode support.

2. Connect leads from the three diodes mounted in supports to output terminal stud. Tighten the attachment screw firmly. Place insulating bushing over relay terminal stud.

3. Place a new seal in the diode end frame.

4. With the end cover in place against the end frame, install the cap screws (7) and lock washers. Tighten the cap screws evenly and firmly.

5. Make sure the drain plug was installed in bottom of the end cover and was securely tightened.

## ALTERNATOR REPLACEMENT

### Removal

1. Place "*Engine control switch*" in engine compartment to the "*Off*" position.

2. Place the 12 and 24 volt battery main disconnect switches to the "*Off*" position.

3. Remove drain plug from bottom of the diode end cover and drain oil into a suitable container. Install drain plug after draining.

4. Disconnect wires #25A from the relay "R" terminal, #107 from the field "F1" terminal regulator and disconnect battery cable from the "DC" terminal on the diode end cover. Tape ends of the battery cable and wires to

prevent short circuits, and tag wires removed from other terminals to aid in identification at time of installation.

5. Disconnect oil supply line from elbow on diode end cover and tape elbow and line to prevent entry of foreign matter. Remove clip securing flexible oil line to bracket on alternator drive end frame.
6. Remove nuts and lock washers from the six mounting studs. Pull the alternator straight back off mounting studs to complete removal.
7. If a new or rebuilt alternator is to be installed, remove driven gear from the alternator for installation on the replacement unit.

### Disassembly of alternator

After diode, field or stator winding checks, the alternator can be disassembled to repair a faulty component, such as field, stator, or to proceed with bearing or rotor replacement. The alternator may be disassembled by following the steps hereafter:

1. Remove nuts and washers from "DC" terminal on diode end frame.
2. Separate the diode cover plate from the diode end frame by removing mounting screws.
3. Remove the washer, nut and lock washer attaching the diode supports to the end frame, the three screws connecting the diode leads to the diode supports, and the three nuts which attach the stator studs to the diode supports.
4. Separate the diode support assemblies from the diode end frame, and the three nuts which connect the studs to the diode end frame.
5. Mark the position of the drive end frame and diode frame with respect to the stator assembly so that the parts can be reassembled in the same position.
6. Detach the diode end frame and field assembly from the stator assembly by removing the attachment screws.
7. Separate the field assembly from the diode end frame by removing the four attachment screws.
8. Separate the rotor assembly and drive end frame from the stator assembly by removing the attachment screws.
9. Remove the shaft nut and washer, and the pinion gear. Press the rotor shaft out of the drive end frame.
10. Remove the retainer plate and pull the bearings from the drive end frame.

## Alternator cleaning and inspection

Whenever the alternator is disassembled, it should be cleaned and inspected as follows:

### Cleaning

If sludge has accumulated on the stator, a light mineral oil should be used to clean the stator.

### Inspection

When the alternator has been disassembled to a point that the stator is exposed, the stator should be checked for the following:

- a) Adequate varnish.
- b) Proper spacing of conductors so that "near shorts" do not exist.
- c) Proper phase lead placement.
- d) Strong conductor and cross-over welds.

## Bearing or rotor replacement

Whenever the rotor and drive end frame are disassembled for any reason, the single-row ball bearing must be replaced with a new one due to the probability of its being damaged during disassembly.

### Removal and disassembly

1. If the driven gear was not removed from the rotor shaft at time of alternator removal, remove the nut and flat washer from the shaft and pull the gear off the shaft.
2. Remove the six (6) bolts and lock washers attaching the drive end frame to the stator frame. Separate the drive end frame from the stator frame, then remove the drive end frame and support assembly.
3. Support the drive end frame in an arbor press in such a manner that the rotor can be pressed down out of the end frame. Using a suitable adapter against the end of the rotor shaft which will pass through the inner race of the double-row ball bearing, press the rotor down out of the end frame and bearings. Since the single-row bearing outer race is held in the end frame by the retainer plate, and the inner race is a press fit on the rotor shaft, the bearing is likely to be damaged when the shaft is pressed out and must be replaced with a new part.
4. Remove the six (6) screws attaching the bearing retainer plate to the drive end frame. Remove the retainer plate, the single-row bearing and the bearing spacer from the end frame.



5. Support the drive end frame in an arbor press, with the double-row bearing down, in such a manner that the bearing can be pressed down out of the end frame. Using a suitable driver which will exert a force on the bearing outer race, press the bearing out of the end frame.

6. Remove the rubber bearing clamp from groove in the end frame.

### Assembly and installation

1. Install a new single-row ball bearing into inner side of the drive end frame. Install the bearing retainer plate and attach with six (6) screws. Stake screws in place after tightening.

2. Position the rubber bearing clamp in groove in bearing bore in the drive end frame. Lubricate the clamp to permit the bearing to be pressed in without dislodging or damaging the clamp.

3. Position the rotor in an arbor press with the shaft end up. Install the drive end frame and single-row bearing assembly over the rotor shaft. Using a driver over the rotor shaft which will exert a force on the bearing inner race, press the bearing onto the shaft until it bottoms against the rotor.

4. Install bearing spacer over the rotor shaft. Position the double-row bearing over the rotor shaft at end frame bore. Using an adapter which will exert a force on both the inner and outer races of the bearing, press the bearing onto the shaft and into the end frame until the inner race bottoms against the bearing spacer.

5. Place a new seal around the drive end of the stator frame.

6. Insert the rotor between the stator and field, and position the drive end frame against the stator frame. Attach the end frame to the stator frame with six bolts and lock washers. Tighten the bolts to a torque of 5 to 5.4 ft.lbs (6-7 N.m).

**NOTE: When replacing the alternator on coach, ensure that an alternator with the proper drive ratio is used. Installation of an alternator with any other drive ratio will result in severe and costly damage to the alternator and engine.**

### Reassembly

Reassembly is the reverse of disassembly. When installing the single-row bearing into the drive end frame, press against the outer race **only** to avoid loading the bearings. Attach the bearing retainer plate, and press against the bearing inner race to force the assembly over the shaft. To avoid pressure on the bronze ring in the rotor, support the inside of the rotor against the shaft, and place the shaft in an upright position to facilitate the assembly procedure. Press against the inner race to force the double-row bearing over the shaft. When attaching the field to the diode end frame, make sure the mating surfaces are perfectly clean and tighten the mounting screw securely.

**NOTE: When tightening the outside nut on the "DC" output terminal, torque the nut to 30-35 ft.lbs (41-47 N.m). The lower nut should be supported while tightening the top nut.**

**NOTE: When reinstalling diodes, tighten to a torque of 9-11 ft.lbs (12-15 N.m).**

### Output check

When removed from the engine, the alternator may be checked on a test bench without circulating oil, providing the output is limited to 100 amperes or less. The alternator may be bench tested without circulating oil at outputs exceeding 100 amperes, as long as the period of operation is limited to less than 15 seconds.

**NOTE: Operating the alternator at outputs greater than 100 amperes for periods exceeding 15 seconds without adequate oil circulation, will cause the alternator to overheat, resulting in damage to the winding and diodes.**

If the alternator is to be operated at an output greater than 100 amperes for longer than 15 seconds, circulating oil must be provided. An SAE 30 engine oil must be supplied to the connection on the diode end cover at a pressure of 35 psi and at a temperature of 60 °F to 220 °F (16 °C to 104 °C). This will provide an oil flow of about one gallon per minute.

To check the alternator on a test bench, make electrical connections as shown in figure 21. Be sure to connect the negative battery terminal to the alternator frame.

## ALIGNMENT OF ALTERNATOR ADAPTER ("8-SHAPED" ADAPTER)

**NOTE:** This procedure applies only to models with alternator mounted on engine without geared adapter housing.

1. Position gasket, ring and "8-shaped" adapter on flywheel housing.

**NOTE:** Gasket must have a notch on inside edge of large circle for proper internal oil drainage. Refer to figure 26 for details.

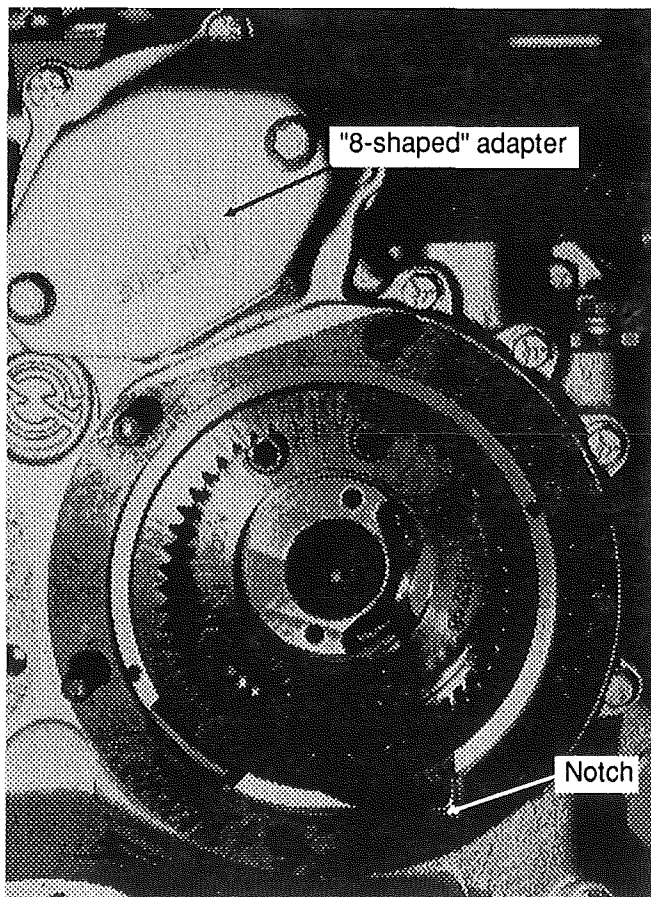

FIG. 26 - Alternator adapter

2. Center the "8-shaped" adapter over cam gear using feeler gauge or other means. Install and tighten the four upper adapter bolts to a torque of 45-50 ft.lbs (54-61 N.m). Adjust the two setscrews to contact flywheel housing.

3. Place magnetic base (for dial indicator) on the hex-head capscrew mounting cam gear to camshaft. Install dial indicator on base and set stylus to contact inside edge of "8-shaped" adapter bore. Set dial indicator to zero.

**NOTE:** A tool, which quickly mounts a dial indicator on the 53-tooth alternator drive gear for alignment of "8-shaped" adapter, is available from Kent-Moore Corporation Service Tool Division (part no J29893) or through a Detroit Diesel Corporation distributor.

**CAUTION:** Engine must always be rotated in a clockwise direction when viewed from engine front. Barreng the engine in the wrong direction will loosen the crankshaft end bolt. Engine damage will result when engine is started. An assistant is necessary to bar engine over while dial indicator is read.

4. Bar engine over. Dial indicator must rotate clockwise at least 180 of one revolution. The "8-shaped" adapter is centered if dial indicator reads within  $\pm .002$  TIR. If satisfactory, proceed with step 6.

5. If runout is more than  $\pm .002$  TIR, loosen the four upper adapter bolts. Back off the two set screws ("Allen screws") and readjust them until dial indicator reads within tolerance when engine is barreng over. Repeat the procedure until the required reading is attained, or until it is determined that the "8-shaped" housing is out-of-round or otherwise defective. Replace as necessary.

6. Remove dial indicator and magnetic base. Tighten the four upper mounting bolts to a torque of 40-50 ft.lbs torque (54-61 N.m).

## BATTERY EQUALIZER

### Description

The battery equalizer is an energy transfer device. It allows power to be taken from a 24 volt battery system at 12 and 24 volts simultaneously. The equalizer is designed to be connected to the batteries continuously much like an alternator. The amount of continuous duty 12 volt current is limited to the capacity (number of amps) of the equalizer. The equalizer causes the 12 volt current draw to be taken from the batteries of the 24 volt system. For example, if a 10 amp, 12 volt load is presented to the system, 5 amps would be supplied by each of the batteries. Any imbalance between the batteries is automatically equalized.

### Battery equalizer troubleshooting

1. Carefully remove the ground (GND) cable from the equalizers. Do not allow this cable to touch any other connection on the equalizer as the other terminals are connected to the batteries.

2. Make sure there is approximately 12 volts between the + 24 and + 12 terminals of the equalizers.

3. Connect a 12 volt load (example: headlights, turn signal, etc.) between the + 12 volt and GND terminals of the equalizers. The lamp should light and stay lit. If the lamp does not light, or light then goes out, the equalizers requires repair.

4. Further verification may be made by measuring the voltages on the equalizer terminals. The lamp used earlier needs to remain connected between the + 12 and GND terminals.
5. Measure the voltage between + 24 and + 12 terminals. Note this reading.
6. Measure the voltage from the + 12 terminal to GND. Note this reading.
7. Compare the two readings by subtracting the + 12 to GND reading from the + 24 to + 12 reading. A properly functioning equalizer is one where the difference is between - 0.5 and + 0.13 volts. For example, the + 24 to + 12 reading might be 12.85 volts. The + 12 to GND voltage might read 12.75 volts. This equalizer would be functioning properly with a 0.10 difference (12.85 minus 12.75 volts) which is within specs.

## VOLTAGE REGULATOR

### Location

The 24 volt regulator is located in the lower section of the A/C breaker & engine junction box near the ATEC and DDEC I modules (DDEC II has only one module which is on the engine).

### Description

The transistor regulator illustrated in figure 27 is an assembly consisting mainly of diodes, capacitors, resistors and transistors. These components are mounted on a printed circuit panel board to form a completely static unit containing no moving parts. Regulators of this type have only **three** (3) terminals which are marked "NEG", "FLD" and "POS".

The regulator components work together to limit the alternator voltage to the preset value by controlling the alternator field current. This is the only function that the regulator performs in the charging system.

The voltage at which the alternator operates is determined by the regulator adjustment. Once adjusted, the alternator voltage remains constant, since the regulator is unaffected by length of service, changes in temperature, or changes in alternator output and speed.

A typical wiring diagram of a negative ground system is illustrated in figure 28. This diagram shows only the basic charging system components, and does not show any components such as the control relays. Refer to "Engine Control" wiring diagram page 1 of 24 in "Wiring diagrams" for the electric circuits and connections.

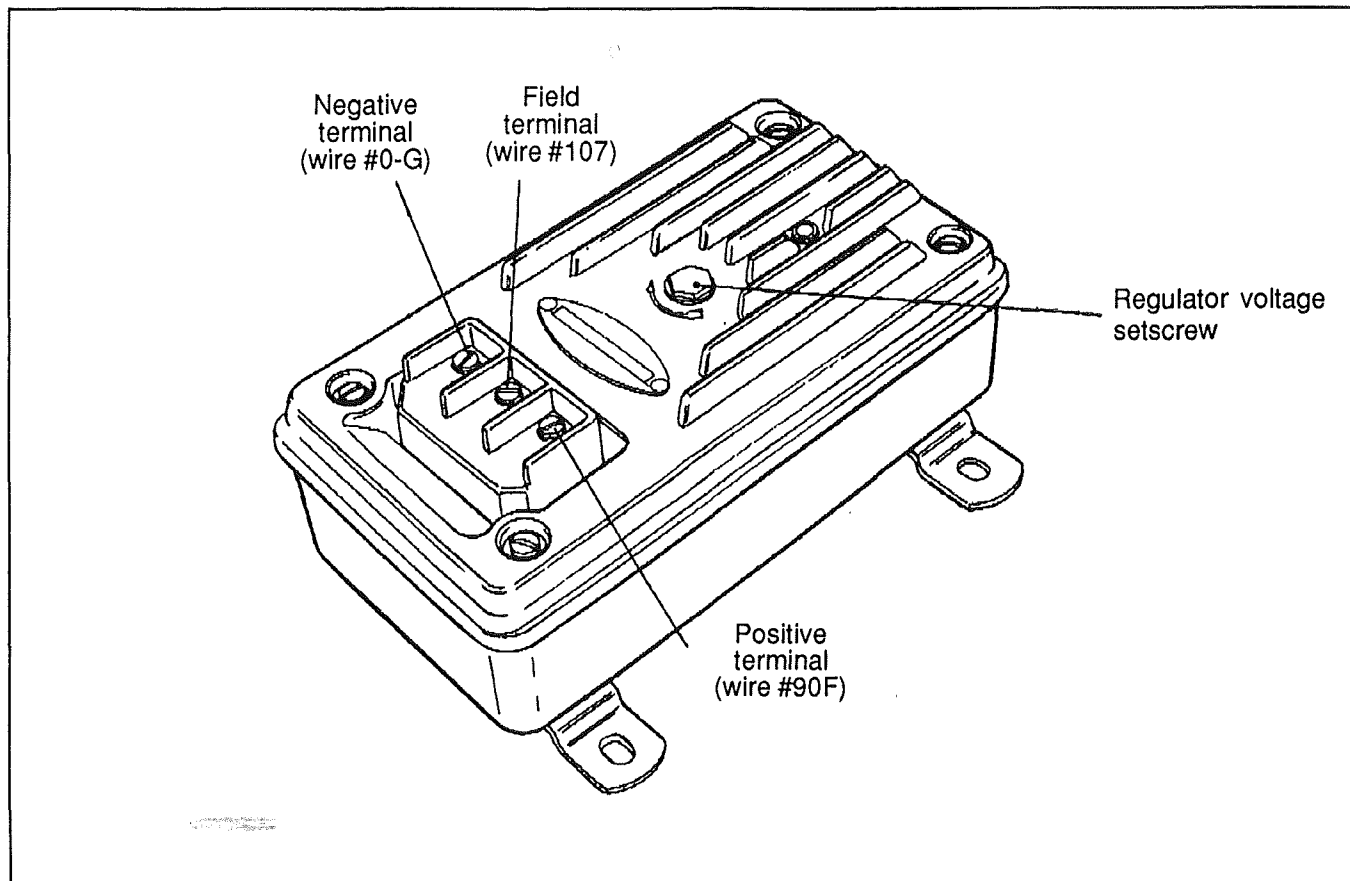

FIG. 27 - 24 volt regulator

MA5-1527.IMG

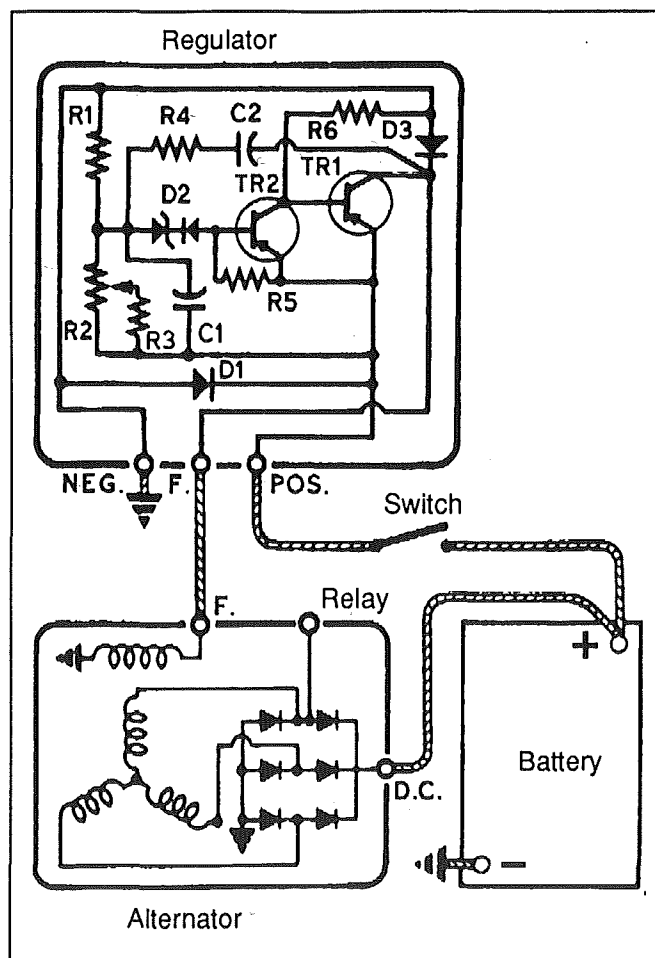

FIG. 28

MA5-1528.JPG

4. If not, the desired setting can be obtained by removing the plug from the voltage regulator cover and turning lightly the adjusting screw inside the regulator; clockwise to increase or counterclockwise to decrease to setting voltage. See figure 30 for details.

**NOTE:** If regulator voltage cannot be adjusted to the specified setting, remove the regulator, repair and/or replace it.

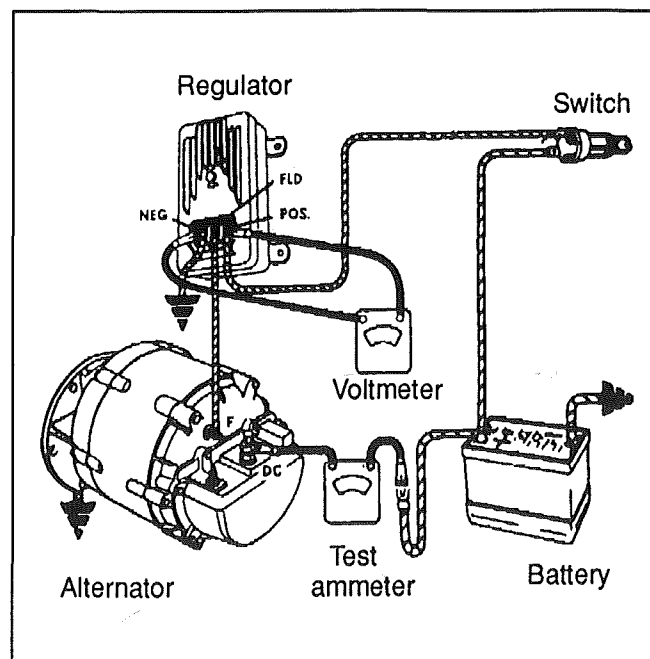

FIG. 29

MA5-1529.JPG

## Troubleshooting procedures

Trouble in the electrical system will usually be indicated by one of these two conditions: an undercharged or an overcharged battery. Either condition can result from an improper voltage regulator setting.

The absence of gassing at the continuous appearance of the green dot in the battery built-in hydrometer indicates that the voltage setting is satisfactory.

## Checking regulator voltage setting

1. To check the voltage setting, connect a voltmeter across the "POS" and "NEG" terminals on the regulator, and an ammeter at the "DC" terminal on the alternator. Refer to figure 29.

2. Operate the engine at approximately 1000 rpm (about 2900 alternator rpm) with accessories turned on to obtain an alternator output of 20-200 amperes.

3. Note the voltage setting; it should be steady at 27.5 volts.



FIG. 30 - Adjusting regulator voltage setting

MA5-1530.JPG

## Undercharged battery

If the voltage setting as checked above is steady and reasonably close to the specified value and the battery is undercharged, raise the setting by 0.3 volt, then check for an improved battery condition over a minimum service period of 48 hours. If the voltage cannot be adjusted to the desired value, the alternator should be checked as follows:

1. Stop alternator, turn off all accessories and disconnect battery ground cable.
2. Disconnect all leads from the regulator and from the alternator field. **Do not allow leads to touch ground.**
3. Connect a voltmeter and an ammeter in the circuit at the alternator "DC" terminal.
4. Connect a jumper lead from the alternator "DC" terminal to the alternator field terminal.
5. Connect a carbon pile resistor load across the battery. Turn to the "Off" position.
6. See the figure 31 for the wiring connections.

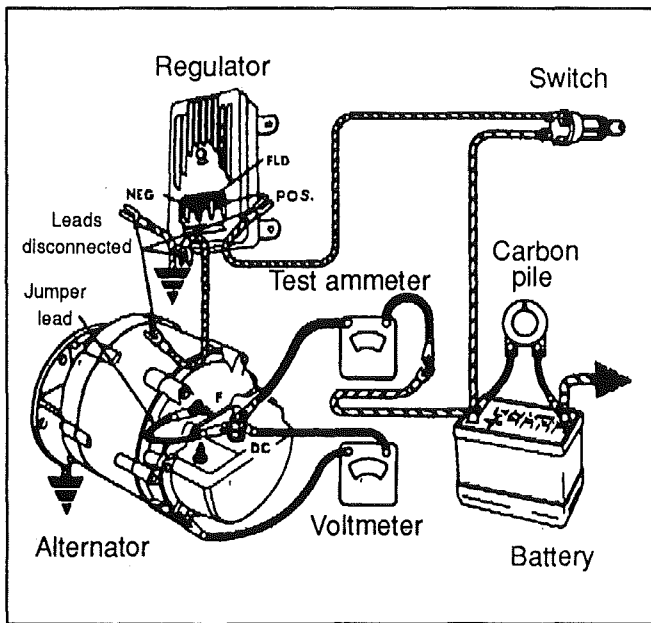

FIG. 31

7. Reconnect battery ground cable.
8. Turn on all vehicle accessories.
9. Operate alternator and adjust carbon pile resistor load as required to check for rated output as given in Delco-Remy Service Bulletin 1G-187 or 1G-188.
10. Check the alternator field winding as follows:

Disconnect the lead from the field terminal and connect an ohmmeter from the field terminal to ground. A resistance reading above normal indicates an open, and a resistance reading less than normal indicates a short or ground. The normal resistance can be calculated by dividing the voltage by the field current published in Delco-Remy Service Bulletin 1G-186, 1G-187, or 1G-

188. The normal resistance value should be at or near midscale on the ohmmeter for accuracy. An alternate method of checking is to connect a battery of specified voltage and an ammeter in series with the field winding and compare readings with published specifications in Delco-Remy Service Bulletin 1G-186, 1G-187, or 1G-188. An alternator is defective if it does not produce rated output or if field windings are faulty. If the alternator provides rated output, and field windings check satisfactorily, the regulator should be checked as covered under heading "Regulator checks".

DEVAIT ÊTRE MÊME CARACTÈRE

## Overcharged battery

If the voltage setting as checked above is steady and reasonably close to the specified value, lower the setting by 0.3 volt and check for an improved battery condition over a minimum service period of 48 hours. If the voltage cannot be adjusted to the desired value, proceed as follows:

Where the alternator field is grounded internally in the alternator as shown in figure 28, a shorted or grounded field or a defective regulator can cause an overcharged battery. The field winding can be checked as covered in "Undercharged battery" section. If the field winding is found not to be defective, the alternator is not defective, and the regulator should be checked as covered under heading "Regulator checks".

## Regulator checks

Separate the cover from the base, and then remove the panel assembly from the cover. Carefully note the location of all washers and lock washers.

The component parts are keyed to figure 28. Before making electrical checks, visually inspect the components and make sure all soldered connections are secure. Various electrical checks with an ohmmeter can be made to determine which components are defective.

The ohmmeter **must** be accurate, and should be a scale-type meter with a 1.5 or 3 volt cell. Most digital ohmmeters can not be used to check semiconductors; however, some digital ohmmeters are specially designed to test semiconductors and can be used to test components in the regulator. Consult the ohmmeter manufacturer concerning the capabilities of his meter.

It is important that all of the following checks be made. If a defective part is found, replace it before proceeding with the remaining checks. Be sure to make all the checks as more than one component may be defective.

A defective regulator can be repaired according to the following methods:

- a) By changing the printed circuit board into the regulator. Unscrew the retaining screws on printed circuit and remove it. Then, install a new printed circuit board. This method is the most commonly used.

b) By removing any retaining screws involved and unsoldering the connections. When resoldering, limit solder time to a minimum as excessive heat may damage the printed circuit and component parts. However, good soldered connections are essential for satisfactory operation. A resin core 63% tin 37% lead solder with a 360 °F (182 °C) melting point is recommended along with a soldering iron rated at 50 watts or less. Use extreme care to avoid overheating. Before checking the printed circuit board, remove transistor TR1, which must be checked separately. Connect the ohmmeter as shown in figure 32, and then reverse the ohmmeter leads to obtain two (2) readings on the same component. Use the middle scale on scale-type meters where the 300 ohm value should be within, or nearly within, the middle third of scale.

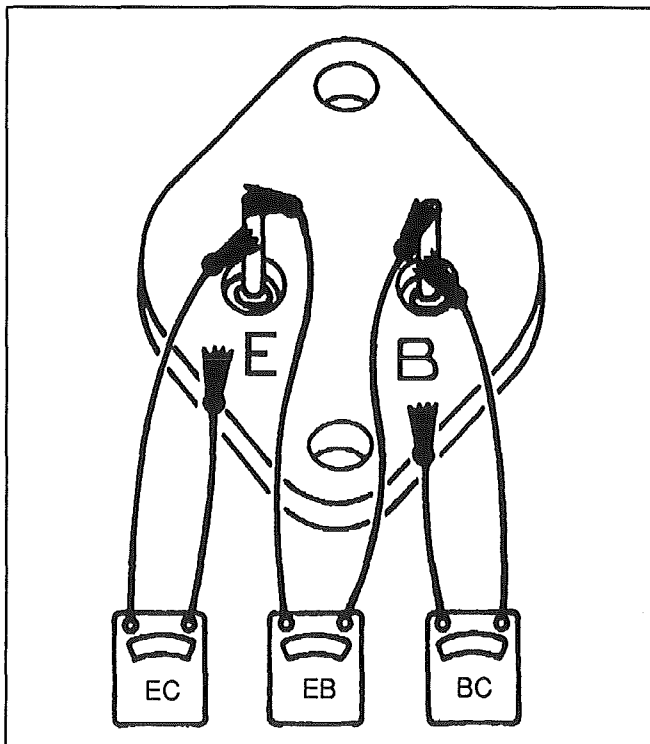

FIG. 32 - Checking transistors TR1

**Capacitors C1 and C2** = The ohmmeter should read high and low on each capacitor. If not, replace capacitor.

**Diodes D1, D2, and D3** = Each diode should give one high and one low reading. If not, replace diode.

**Resistor R2** = Turn voltage adjustment screw (identified in figure 30) with ohmmeter connecting each way. Reading should change as slotted screw is turned. If not, replace R2.

**Transistor TR2** = Change the ohmmeter to use the low scale. Check EB should read low and high. Check BC should read low and high. Check EC should both read high. If not replace TR2 (see fig. 33).

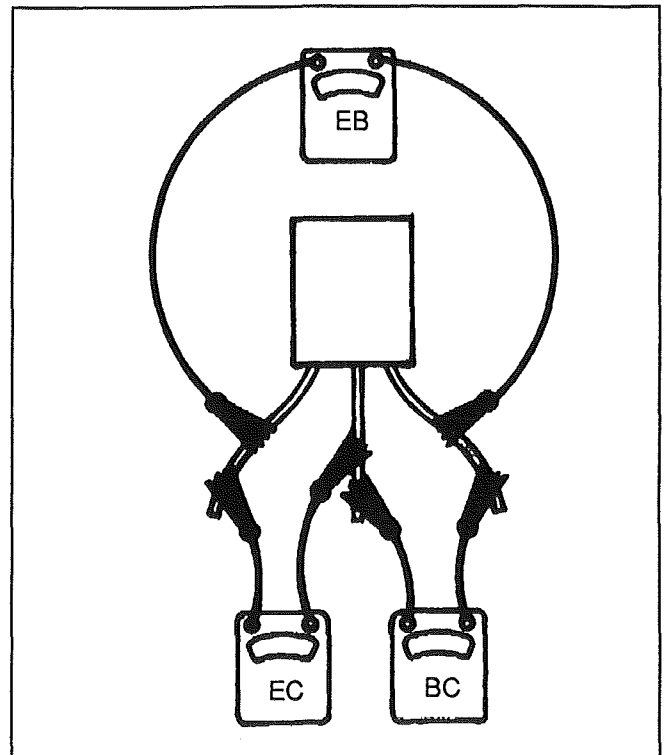

FIG. 33 - Checking transistors TR2

**Transistor TR1** = See figure 32. Use the low scale. Each of the three checks should read low and high. If not replace TR1.

### Adjusting voltage

After repair, the regulator must be adjusted to the desired voltage setting. Follow the procedure under previous heading "Checking voltage setting". Turn **slowly** the adjusting screw full range and observe the voltmeter to insure that the voltage is being controlled, then adjust, **always slowly**, to the desired setting.

## STARTING MOTOR

### Description

The starting motor has the shift lever and solenoid plunger that are totally enclosed to protect them from exposure to dirt, icing conditions and splash.

Positive lubrication is provided to the bronze bushing located in the commutator end frame, in the lever housing and in the hose housing, by an oil saturated wick that projects through each bushing and contacts the armature shaft.

The clutch is a "Positork" drive type, moved into mesh with the ring gear by the action of the solenoid. Once engaged, the clutch will not disengage during intermittent engine firing, which prevents damage to pinion and ring gear teeth. The pinion remains engaged until starting is assured and the solenoid circuit is interrupted. Refer to figure 34 for more details.

### Maintenance

All wicks and oil reservoirs should be saturated with SAE 10 oil, and the splines underneath the clutch should be lubricated with a light coating of SAE 10 oil. Other than

normal periodic lubrication and keeping cable connections clean and tight, the starting motor should require no periodic maintenance. However, under normal operating conditions, the starting motor should be disassembled, inspected, cleaned and tested at time of engine overhaul.

### Starting motor tests

To obtain full performance data on a starting motor, or to determine the cause of abnormal operation, the starting motor should be subjected to the following tests. These tests are performed with the starting motor removed from the engine. Check the armature for freedom of rotation by prying on the pinion with a screwdriver. Tight bearings, a bent armature shaft, or a loose pole shoe screw will prevent the armature from turning freely. Failure of the starting motor to perform according to specifications will require disassembling the motor for further checks and adjustments. However, if the armature does rotate freely, the motor should be given a no-load test before disassembly.

**CAUTION:** Never operate the starting motor more than 30 seconds at a time without pausing to allow it to cool for at least 2 minutes. Overheating, caused by excessive starting will seriously damage the starting motor.

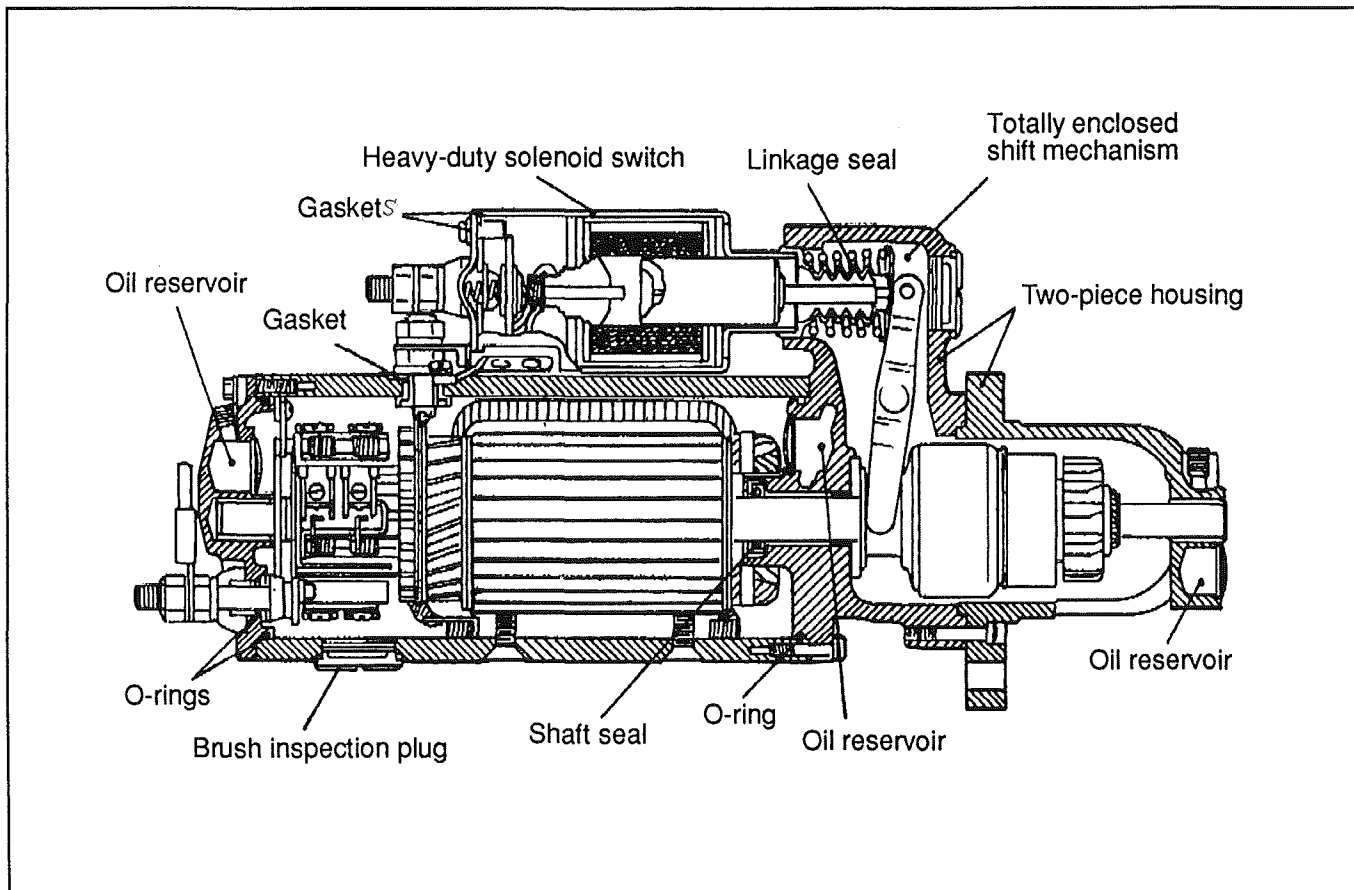

FIG. 34 - Starting motor construction

MA5-1534.IMG

## No-load test

Before disassembling the starting motor, the following check of starting motor operation should be made to determine condition which may require special attention during overhaul. Make test connections at the starting motor as follows:

Connect the starting motor in series with fully charged batteries to give 24 volts, an ammeter capable of reading several hundred amperes, and a variable resistance. Also connect a voltmeter as illustrated in figure 35 from the battery terminal to the motor frame. A rpm indicator is necessary to measure armature speed. Proper voltage can be obtained by varying the resistance unit.

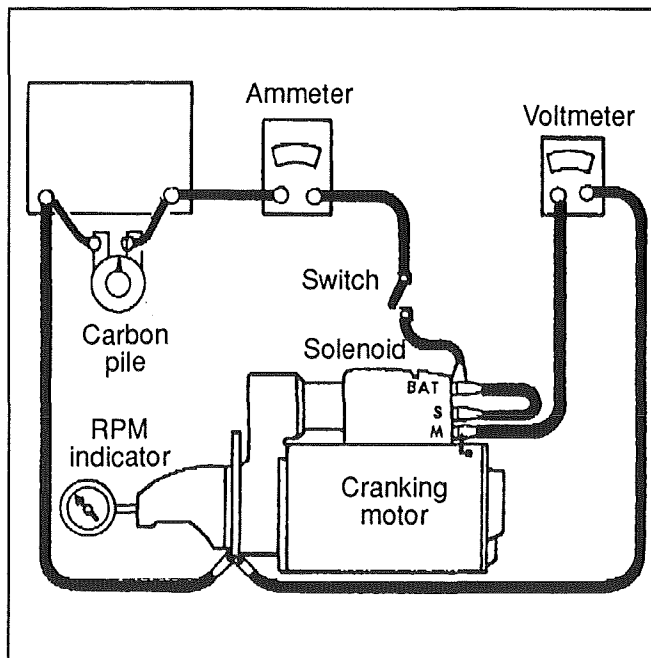

FIG. 35 - Circuit for no-load test

## No-load test results

- Rated current draw and no-load speed indicate normal condition of the starting motor.
- Low free-speed and high current draw indicate the following:
  - Excessive friction; tight, dirty, or worn bearings, bent armature shaft, or loose pole shoes allowing the armature to drag.
  - Shorted armature. This can be further checked on a growler after disassembly of the starting motor.
  - Grounded armature or fields. Check further after disassembly.
- Failure of the starting motor to operate with high current draw indicates the following:
  - A direct ground in the terminal or fields.
  - "Frozen" bearings. This should have been determined by turning the armature by hand.

4. Failure to operate with no current draw indicates:

- Open field circuit. This can be checked after starting motor disassembly by inspecting internal connections and tracing circuit with a test lamp.
- Open armature coils. Inspect the commutator for badly burned bars after disassembly.
- Broken brush springs, worn brushes, high insulation between the commutator bars or other causes which would prevent good contact between the brushes and commutator.

5. Low no-load speed and low current draw indicate high internal resistance due to poor connections, defective leads, dirty commutator and causes listed previously in step 4.

6. High free-speed and high current draw indicate shorted fields. If shorted fields are suspected, replace the field coil assembly and check for improved performance.

## Lock-torque test

The lock-torque test requires the equipment illustrated. A variable resistance with a high current capacity should be used. The starting motor should be securely mounted and a brake arm hooked to the drive pinion. When specified current is applied, the torque can be computed from the reading on the scale. A one foot brake arm will directly indicate foot-pounds.

**WARNING: This test requires extreme caution. Follow instructions carefully.**

## Disassembly

Normally the starting motor should be disassembled only so far as is necessary to make repair or replacement of the defective parts. As a precaution it is suggested that safety glasses be worn when disassembling or assembling the cranking motor.

- Note the relative position of the solenoid, lever housing, and nose housing so the motor can be reassembled in the same manner.
- Disconnect field coil from solenoid motor terminal, and lead from solenoid ground terminal.
- On motors with brush inspection plugs, remove the plugs and then remove the brush lead screws. This will disconnect the field leads from the brush holders.
- Remove the attaching bolts and separate the commutator end frame from field frame.
- Separate the nose housing and field frame from lever housing by removing attaching bolts.
- Remove armature and clutch assembly from lever housing.
- Separate solenoid from lever housing by pulling apart.



## Cleaning

The driving mechanism armature and fields should not be cleaned in any degreasing tank, or with grease dissolving solvents, since these would dissolve the lubricants in the drive mechanism and damage the insulation in the armature and field coils. All parts except the drive should be cleaned with mineral spirits and a brush. The drive can be wiped with a clean cloth.

If the commutator is dirty, it may be cleaned with No. 00 sandpaper.

**CAUTION: Never use emery cloth to clean commutator.**

## Armature servicing

If the armature commutator is worn, dirty, out of round, or has high insulation, the armature should be put in a lathe so the commutator can be turned down. The insulation should then be cut 1/32" (0,79 mm) wide and 1/32" (0,79 mm) deep, and the slots cleaned out to remove any trace of dirt or copper dust. As a final step in this procedure, the commutators should be sanded lightly with No. 00 sandpaper to remove any burrs left as a result of the undercutting procedures.

The armature should be checked for opens, short circuits and grounds as follows:

### Opens circuit test

Opens are usually caused by excessively long starting periods. The most likely place for an open to occur is at the commutator riser bars. Inspect the points where the conductors are joined to the commutator bars for loose connections. The poor connections cause arcing and burning of the commutator bars as the starting motor is used. If the bars are not too badly burned, repair can often be performed by resoldering the leads in the riser bars (using rosin flux), and turning down the commutator in a lathe to remove the burned material. The insulation should then be undercut.

**CAUTION: Do not undercut the insulation between the commutator segments after turning down the commutator.**

### Short circuit test

Short circuits in the armature are located by means of a growler. When the armature is revolved in the growler with a steel strip such as a hacksaw blade held above it, the blade will vibrate above the area of the armature core in which the short circuit is located. Shorts between bars are sometimes produced by brush dust or copper between the bars. These shorts can be eliminated by cleaning out the slots.

## Ground test

Grounds in the armature can be detected by the use of a 110 volt test lamp and test points. If the lamp lights when one test point is placed on the commutator with the other point on the core or shaft, the armature is grounded. Grounds occur as a result of insulation failure, which is often brought about by overheating of the starting motor produced by excessively long starting periods, or by accumulation of brush dust between the commutator bars and the steel commutator ring.

## Field coil checks

The field coils may be checked for grounds and opens by using a test lamp.

### Grounds

If the motor has one or more coils normally connected to ground, the ground connections must be disconnected during this check. Connect one lead of the 110 volt test lamp to the field frame and the other lead to the field connector. If the lamp lights, at least one field coil is grounded, and it must be repaired or replaced.

### Opens

Connect test lamp leads to ends of field coils. If lamp does not light, the field coils are open.

## Field coil removal

Field coils can be removed from the field frame assembly by using a pole shoe screwdriver. A pole shoe spreader should also be used to prevent distortion of the field frame. Careful installation of the field coils is necessary to prevent shorting or grounding of the field coils as the pole shoe is tightened into place. Where the pole shoe has a long lip on one side and a short lip on the other, the long lip should be assembled in the direction of armature rotation so it becomes the trailing (not leading) edge of the pole shoe.

## Reassembly

The reassembly is the reverse of disassembly.

To reassemble the end frame with brushes onto the field frame, pull the armature out of the field frame just far enough to permit the brushes to be placed over the commutator. Then push the commutator end frame and the armature back against the field frame.

The recommended torque for the cross-slotted pole shoe screws is 25-35 ft.lbs (34-47 N.m).

## Lubrication

All wicks and oil reservoirs should be saturated with SAE 10 oil. The splines underneath the drive (on the shaft) should be wiped clean but not oiled. Oil in this area may cause failure to engage at very cold temperatures.

## Pinion clearance

Pinion clearance should be checked after reassembly of motor to ensure the clearance is within specifications. To check pinion clearance (starting motor off engine), first disconnect the motor field connector from the solenoid motor terminal. Connect 24 volt battery with the positive battery lead to the solenoid switch terminal (5), and the negative battery lead to the grounded (G) solenoid terminal. Momentarily flash a jumper lead from the solenoid motor terminal to the grounded (G) solenoid terminal. The pinion gear will now shift into cranking position and remain so until the battery is disconnected. Push the pinion or drive back towards the commutator end to eliminate slack movement. Measure the distance between pinion and pinion stop. This should be  $\frac{23}{64}'' \pm \frac{1}{32}''$  ( $9,5 \text{ mm} \pm 0,79 \text{ mm}$ ). Pinion clearance is adjusted to these limits by turning the solenoid shaft nut after removing access plug in shift housing (see fig. 36).

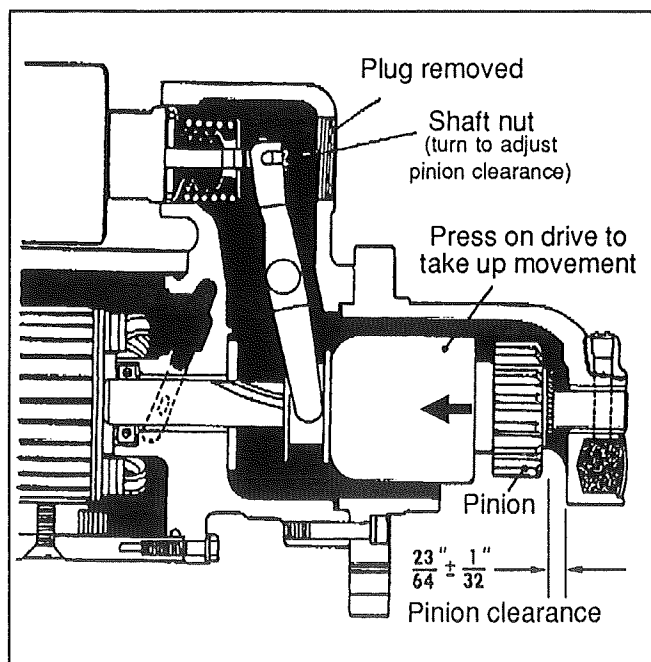

FIG. 36

## Starter solenoid

### Description

The starting motor solenoid shifts the starting motor pinion into mesh with the flywheel ring gear and also closes the electric circuit to energize the starting motor.

There are two windings in the solenoid: a pull-in winding and a hold-in winding. Both windings are energized when the external control switch is closed. They produce a magnetic field which pulls the plunger in so that the drive pinion is shifted into mesh, and the main contacts in the solenoid switch are closed to connect the battery directly to the starting motor. Closing of the main switch contacts shorts out the pull-in winding since this winding is connected across the main contacts. The magnetism produced by the hold-in winding is sufficient to hold the plunger in, and shorting out the pull-in winding reduces drain on the battery. When the control switch is opened momentarily, the pull-in winding and the hold-in winding are connected in series between the battery and common ground.

The polarity of the pull-in winding is reversed and opposes the magnetic pull of the hold-in winding. All magnetic holding force on the solenoid plunger is thus cancelled. The return spring then quickly pulls the solenoid plunger back, opening the solenoid switch contacts and at the same time withdrawing the pinion gear from the meshing position. Proper operation of the switch depends on maintaining a definite balance between the magnetic strength of the pull-in and hold-in windings.

This balance is established in the design by the size of wire and the number of turns specified. An open circuit in the hold-in winding or attempts to start with a discharged battery may cause the switch to chatter.

### Disassembly

To disassemble the solenoid, remove nuts, washers, and insulators from the switch terminal and battery terminal. Unscrew cover screws and remove cover. Take out the contact disk assembly.

### Solenoid maintenance

The solenoid requires no periodic maintenance other than keeping the terminals clean and tight. Always check action of the solenoid if it has been removed. If the unit fails to function, first check wiring before condemning the solenoid. Solenoid windings can be checked for current draw, open circuit, or shorts.

## Solenoid tests

Two tests must be made to determine the current draw of (1) both windings in parallel and (2) the hold-in winding alone. The solenoid windings can be tested with the solenoid either off or on the starting motor. However, when the solenoid is checked on the starting motor, it is necessary to disconnect both leads at the main solenoid terminals to prevent interference. The main solenoid terminal which is normally connected to the starting motor must then be grounded to the solenoid base by means of a jumper lead. For the first test, connect a source of variable voltage (battery and a variable resistance) in series with an ammeter between the solenoid base and the solenoid small switch terminal. Connect a voltmeter between the same two points. Slowly increase voltage and note the current draw. This should be 55-63 amps at 24 volts. Disconnect the jumper lead grounding the main solenoid terminal and readjust the variable resistance to obtain the specified voltage of 24 volts. This should not exceed 6.8 amperes.

When the solenoid has been removed from the starting motor for repair or replacement, the linkage must be adjusted to provide the correct pinion clearance when the solenoid is remounted on the starting motor. See "Starting motor" earlier in this section for correct pinion clearance adjustment.

## Recommendations

1. Tag each lead to ensure correct connections when the starting motor is reinstalled.
2. Tighten the 5/8"-11 starter attachment bolts to a torque of 137-147 ft.lbs (186-200 N.m).
3. Keep all the electrical connections clean and tight.
4. When installing wiring terminal leads to the starting motor and the solenoid switch, torque the No. 10-32 connections to 16-30 in.lb (2-3 N.m) and the 1/2"-13 connections to 20-25 ft.lbs (27-34 N.m).

## ENGINE HEATERS

### Block heater

An engine block heater is available as standard equipment. It consists of a 115 volt, 1500 watt, single loop element type, fitted on front left side of engine block forwards the crankcase dipstick. It is plugged into a socket on the engine, but is operated by a switch located in front ~~left~~ side service door.

WV H3-40  
COMPARTMENT

### Oil pan heater

*Demande spéciale de Voyagers ??*

An oil pan immersion heater is available as optional equipment. It consists of a 115 volt, 150 watt single loop element type fitted on the oil pan side. Refer to the following procedure when installing an oil heater.

### Installation

1. Drain oil pan.
2. Remove 1/2" NPT plug nearest bottom of oil pan. If pipe plug is larger, use a reducer bushing.

**NOTE: Maximum results are obtained when heater is installed as low as possible in the oil.**

3. Coat heater threads with gasket cement or teflon tape and install heater securely.
4. Insert cord connector into heater receptacle.
5. Run power supply cord as required, placing cable ties where necessary to eliminate cord pull and contact with moving parts and exhaust manifold.
6. Refill oil pan.
7. To eliminate possibility of oil carbonizing on heater element, heater should be connected to power source while engine oil is warm.

**WARNING: Before connecting heater to power source make sure that the element is immersed in oil. Never energize heater in air. If so energized, element sheath could burst causing personal injury.**

### Maintenance

An annual inspection of the oil heater is necessary. Remove and clean heater element.

## LIGHTING SYSTEM

Circuits for interior and exterior lights as well as their control switches, relays and circuit breakers are shown on the applicable wiring diagrams further in this section under "Electric circuit diagrams".

## EXTERIOR LIGHTING EQUIPMENT

### Headlights

Each headlight assembly consists of two 12 volt halogen rectangular sealed-beam units. Outer lamps are double-filament units, having high and low beams. Inner lamps have single-filament and operate with high beam of outer units. For identification purposes, outer units are molded with "2A" and inner units are molded with "1A" in top of the lens.

### Headlight dimmer switch

The multifunction lever located on the steering column is used to select proper lighting. High beams or low beams can be selected by respectively pushing the lever towards the dashboard or pulling it towards the driver. A high beam indicator on the central dashboard panel is illuminated when the high beam circuit is energized.

**NOTE: High beams can be flashed momentarily by pulling the lever completely towards the driver and then releasing it.**

### Maintenance

Clean with soap and water and a good glass cleaner whenever dirty. For maximum illumination, headlight connections must be coated with a dielectric grease to prevent oxidation and proper voltage must be maintained. Low battery voltage, loose or dirty contacts in wiring system and poor ground contribute to a decrease in voltage. Check wiring and connections regularly and keep battery properly charged. When a headlight burns out, a complete new sealed-beam unit must be installed.

Headlights must be properly aimed to provide maximum allowable road illumination. When using mechanical aimers, follow manufacturer's instructions.

Headlight aim should be checked after installing a new sealed-beam unit. Aiming can be performed without removing headlight bezels. Horizontal and vertical aiming of each sealed-beam unit is provided by two adjusting screws which move the mounting ring in the body against the tension of the coil spring (see fig. 37). There is no adjustment for focus since the sealed-beam unit is set for proper focus during manufacturing assembly.

### Headlight adjustment

The following is a general procedure for headlight adjustment using a mechanical equipment, such as a "Bear 47-132 headlight aligner". If your mechanical equipment is different, refer to the manufacturer's instruction manual.

### Setting aligner according to slope

The floor level offset dial must match with slope to ensure a precise alignment.

1. Park vehicle on a level floor.
2. Fix one (1) calibration fixture to each aligner.
3. Install aligner in center of each wheel on one side of vehicle. Unit B must be installed besides the first (1) axle wheel with its viewing port facing rearward, and unit A besides the fourth (4) axle wheel with its viewing port facing forward. See figure 38 for more details.

**NOTE: Be sure that the three (3) indicators on each module are set to the zero point.**

4. Level each unit by means of the thumb adjusting screw on the fixture until level-vial bubble is centered.
5. Look through the top port hole of unit A, and turn horizontal knob until split images are aligned (see fig. 39).

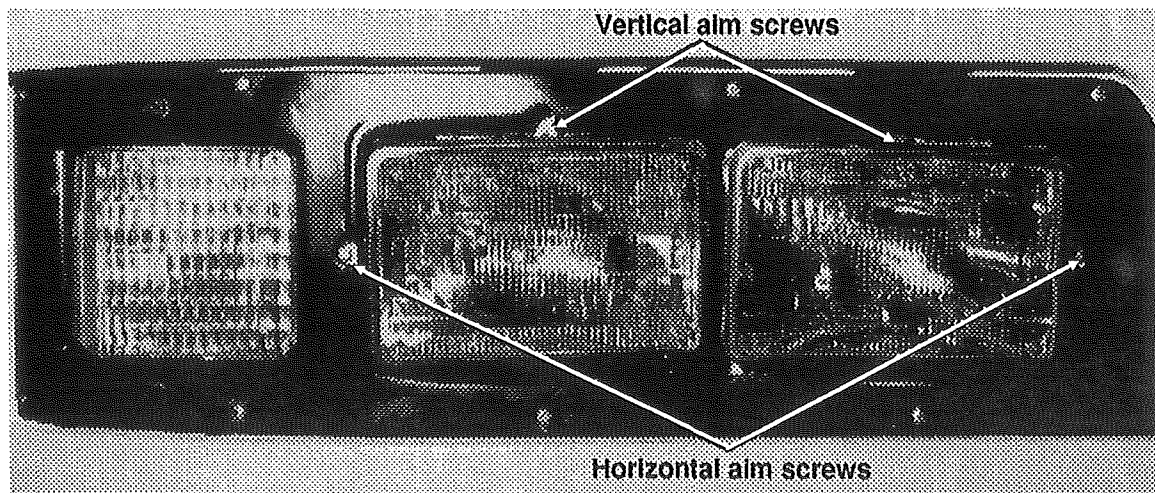

FIG. 37 - Headlight assemblies

MA5-1537.IMG

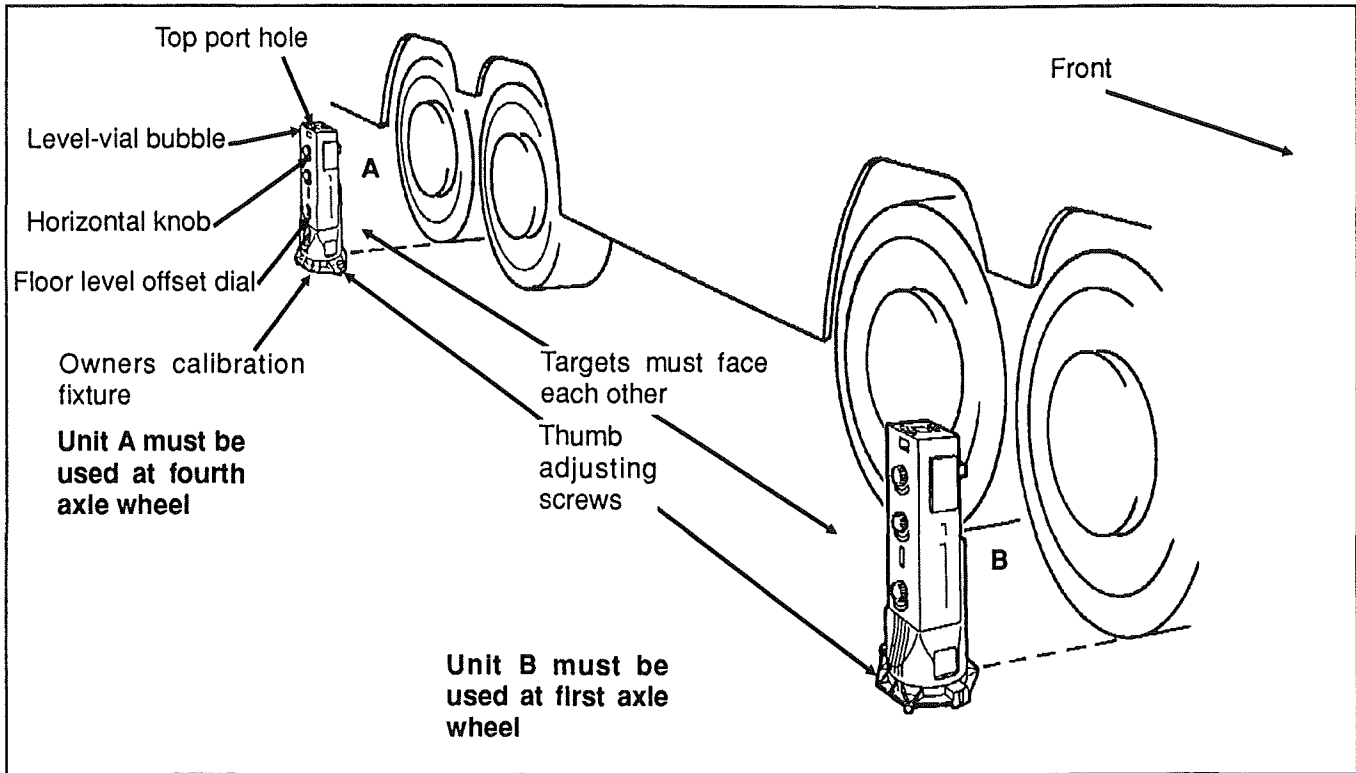

FIG. 38

MA5-1538.IMG

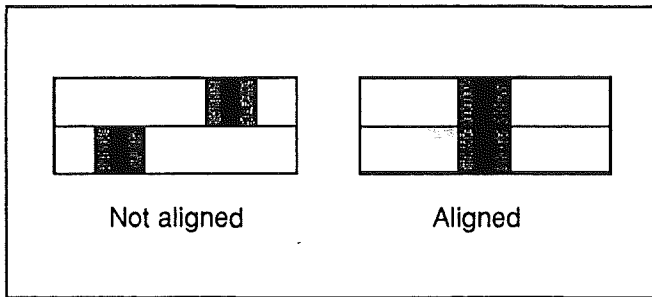

FIG. 39

MA5-1539.IMG

6. Set according to floor slope. Transfer positive (+) or negative (-) reading of horizontal dial to the floor level offset dial to offset floor slope on each aligner (see fig. 40). Push on the floor level offset dial to register reading.

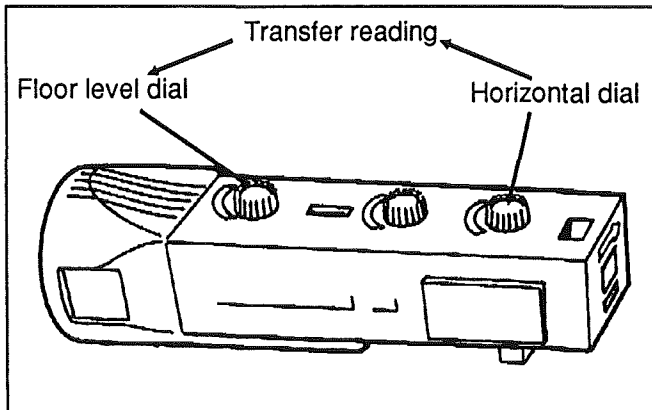

FIG. 40

MA5-1540.IMG

7. Remove calibration fixture from each unit.

**NOTE: If vehicle remains stationary during the headlight alignment procedure, avoid checking floor slope each time.**

**Headlight alignment**

The aligner is provided with adaptors for different sizes of headlights which are always aligned in pairs.

1. Fix the adequate adaptor on each headlight.

**NOTE: The adaptors are equipped with steel inserts, thus providing a good seating for a precise headlight adjustment.**

2. Install aligners on headlights (unit A on driver's side and unit B on other side with the sight openings facing each other), by pushing the handle forward to secure rubber suction disc, then pull handle until it locks. Refer to figure 41.

**NOTE: Ensure that floor level offset dial is set adequately before aligning headlights.**

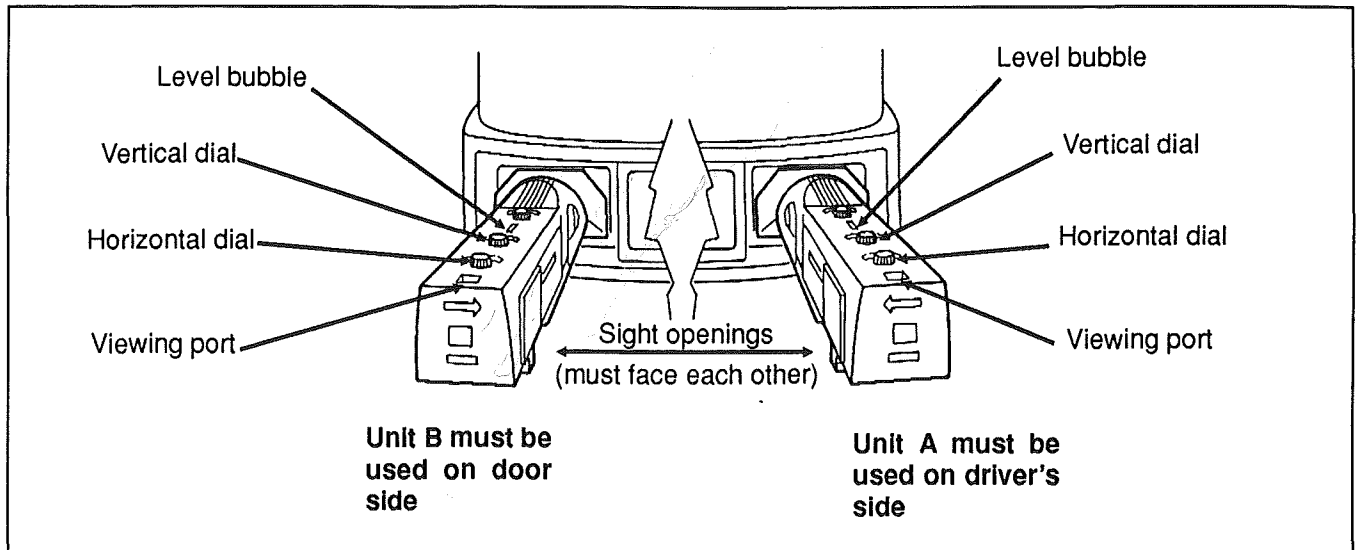

FIG. 41

MA5-1541.IMG

### Horizontal alignment

1. Reset horizontal dial to zero.
2. Check that split image is visible in the viewing port. If not, replace aligner by turning it.
3. Turn the horizontal aim adjusting screw of each headlight until split image is aligned (see fig. 42).

### Vertical alignment

1. Reset vertical dial to zero.
2. Turn the adjusting screw of the headlight vertical aim until bubble is centered (see fig. 42). Repeat operation on other headlight.

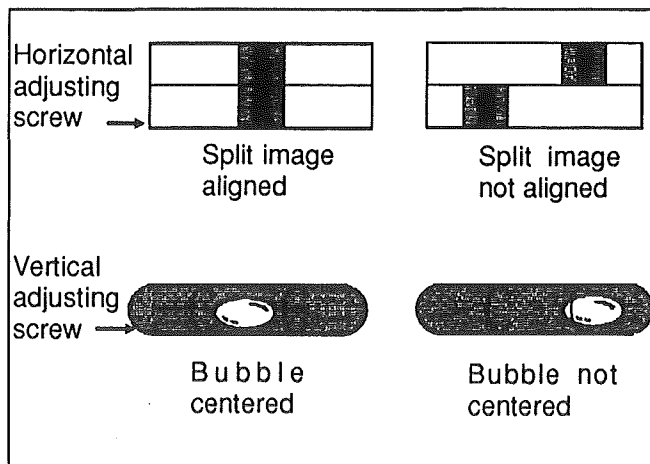

FIG. 42

MA5B1542.IMG

3. Recheck the horizontal alignment.
- Remove aligners by pressing on vacuum release button.
- Repeat the same procedure for the high beams.

If mechanical equipment is not available, perform adjustments as described below:

1. Park vehicle on level floor so headlights are 25 feet (7,6 m) from a smooth surface preferably of light color. A door or wall is suitable. Center line of vehicle should be perpendicular to this vertical surface.
2. Draw a horizontal line on vertical surface at height of light center. Locate point on this horizontal line at which projected centerline of vehicle intersects. Measure distance between light centers and divide this distance equally on either side of center mark. Then draw two vertical lines directly ahead of each light center.
3. Switch on high beams and cover one headlight while adjusting other.
4. When aiming headlights, beam may appear distorted. A new sealed-beam unit must be installed to correct this condition.
5. After headlight is properly aligned, cover it and proceed in the same manner as above with opposite headlight.

### Sealed-beam unit replacement

#### Removal

1. Remove screws attaching headlight bezel to front panel (12 "Phillips" screws) and remove bezel.
  2. Remove four (4) mounting screws attaching sealed-beam unit retaining ring to mounting ring.
- NOTE: Do not disturb headlight adjusting screws.**
3. Remove sealed-beam unit and pull wiring connector off back of unit.

## Replacement

1. Install wiring connector on back of sealed-beam unit. Position unit in mounting ring with molded lens number at top.

**NOTE: Sealed-beam units with number "1A" molded in top of the lens must be used at inside light positions. Units identified by number "2A" molded in top of the lens must be used at outside light positions.**

2. Position the retaining ring over the lens and secure it to the mounting ring with four screws.

**NOTE: The headlight aim must be checked and adjusted even if it was properly adjusted before the sealed-beam unit was replaced, and adjusting screws were not removed.**

3. After installing and adjusting the headlight assembly, install the headlight bezel.

## Front turn signal

The front turn signal is a part of the front headlight cluster. The turn signal lens is located on each front corner and shares a common bezel with the headlights. Turn signal is visible from both front and side.

## Removal and replacement

1. Remove the twelve (12) "Phillips" screws attaching the headlight bezel, then remove it.
2. Remove socket from headlight bezel.
3. Remove the bulb by pushing and rotating it out of the socket.
4. Replace the new bulb by reversing sequence of the previous step.

## Stop, tail, directional, back-up, and hazard warning lights

A combination stoplight, taillight, directional signal light and back-up light assembly is mounted on each side at rear of vehicle. Furthermore, when braking, a center stoplight will illuminate simultaneously with the stoplights for increased safety.

The stop, tail, directional signal and back-up lights consist of individual bulbs mounted in a common housing, and each light is serviced individually as a complete unit and need only to be plugged into or unplugged from socket after removing proper light lens.

The hazard warning flashing system uses simultaneously the front, side, and rear directional lights. This system is energized by a switch on the L.H. dashboard control panel.

## Removal and replacement

1. Unscrew the retaining lens screws (2), then remove the lens.

2. Remove the bulb by pushing and then rotating it counterclockwise out of the socket.

3. Place the new bulb by pushing and rotating it clockwise, then replace the lens; the inscription "Hella" molded on the lens must be located upwards.

**NOTE: Taillights are provided with a different candle power bulb. Be sure to replace defective bulb by the appropriate one.**

## License plate light

A license plate sealed unit is mounted above the license plate at rear of vehicle. In case of burn out, the sealed unit must be changed according to the following procedure.

1. Pry out the rubber seal with a little screwdriver, then pull on the sealed unit and disconnect it.
2. Reconnect new sealed unit, place rubber seal, and press on it until it is seated in its former position.

## Clearance and marker lights

This vehicle is equipped with marker and clearance lights. The clearance lights are mounted at each corner of the coach near the top and in upper center of rear and front sections. They are red at the rear and yellow at the front.

The yellow marker lights are mounted near the center of vehicle on each side of the coach.

## Marker light bulb removal and replacement

The marker light bulbs can be replaced as per the following procedure:

1. Unscrew both "Phillips" screws retaining the side marker lens.
2. Push and rotate the bulb counterclockwise in order to remove it from its socket.
3. Push new bulb into the socket, then rotate clockwise.
4. Position lens on housing, then place and screw the "Phillips" screws.

## Clearance light bulb removal and replacement

The clearance light bulb can be replaced as per the following procedure.

1. Unsnap the lens.
2. Push and rotate the bulb counterclockwise to remove it.

3. Push new bulb into the socket, turn clockwise, then replace the lens and press on it.

## Docking and cornering lights

Four (4) halogen headlights are installed on this vehicle. Two on rear section for docking lights and two on front section for cornering lights. Both docking lights are mounted behind the rear section wheels and light automatically when reverse range is selected to facilitate reverse or docking procedure.

One cornering light is mounted on the L.H. side steering compartment door, while the other is located between the front wheel and the entrance door on the R.H. side. The main function of these lights is to increase lateral visibility when turning a corner. These lights are energized simultaneously with the directional lights.

## Removal and replacement

Both docking and cornering headlights can be changed according to the following procedure:

1. Unscrew the two "Phillips" screws of the retaining ring.
2. Disconnect the light unit connection.
3. Press on each tab of retaining clip, bring both tabs together, then lift the retaining clip.
4. Remove the bulb.
5. Position new bulb, place the retaining clip, then bring both tabs together; when the retaining clip is in position, release the tabs.

**CAUTION:** During this step, avoid contacting the bulb with your fingers, otherwise this could alter the bulb life.

6. Connect and then position the light unit.
7. Finally, place and screw the retaining ring.

## Fog lamps

Optional halogen fog lamps can be mounted on this vehicle to allow the driver a better visibility in foggy weather, or to improve the range of vision just ahead of the coach.

## Removal and replacement

1. Remove the protector cap on light unit (if so equipped), then unscrew the light unit retainer screw and slide upward the retainer.
2. Remove the light unit, then disconnect the light unit connection.
3. Move the tabs of retaining clip out of its notches, then lift the retaining clip and remove the bulb.

4. Place the new bulb, then replace the retaining tab of clip to its position into the notches.
5. Reconnect the light unit connection, then place the light unit to its proper position.
6. Replace the retainer and screw it.
7. Replace the light unit cover (if so equipped).

## INTERIOR LIGHTING EQUIPMENT

The instrument gauges and switches mounted on all control panels are energized whenever the exterior light switch is pushed to the first position. A control dimmer at the extremity of the L.H. side control panel is used to vary the brightness of the panel gauges, switches and indicator lights.

The gauge lights, panel lights, switch lights and indicator lights have a different bulb arrangement. So, the procedure to change a defective bulb can vary according to the application.

## Switch bulb replacement

1. Pull slightly the switch with a defective bulb away from the control panel.
2. Using a little screwdriver, press the tab on top of the switch housing, then pull the switch away from the control panel.
3. Use the same screwdriver and press on the light bulb housing tab in order to remove it from the switch.
4. The light bulb may be removed by pulling it away.
5. Push the new bulb into the socket to install it.
6. Place the light socket and push to its former position.
7. Replace the switch on control panel.

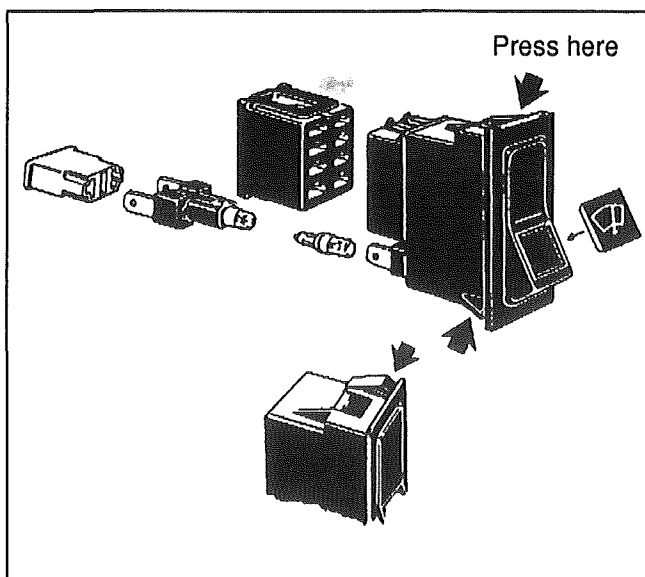

FIG. 43 - Panel switch

MA5-1543.IMG



## Indicator light bulb replacement

1. Remove the indicator light symbol cover.
2. With a ballpoint pen cap or manually, push the bulb into the socket, then twist off the bulb as it pulls out of the housing.
3. Place a new bulb, push on and twist it counterclockwise with a ballpoint pen cap or manually.
4. Replace the symbol cover, then push on until it snaps.

**NOTE:** The bulbs of the "Check engine" and "Stop engine" warning lights are 12 volts instead of 24 volts as in the case of all other indicator/warning lights.

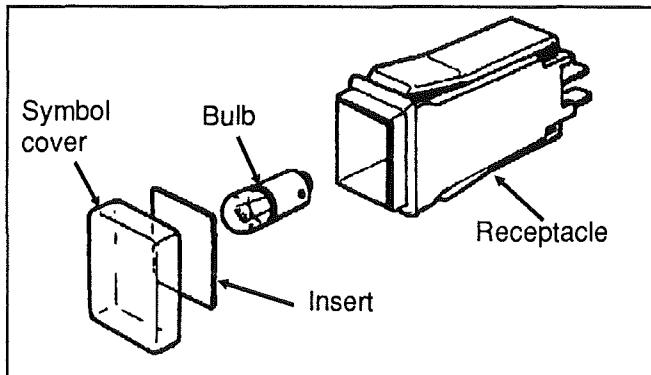

FIG. 44 - Indicator light

MA5-1544.JPG

## Gauge light bulb replacement

1. For any gauge light bulb replacement, the rear dashboard housing must be removed in order to have access to the rear of gauges.
2. Remove bulb socket from the gauge, turn the defective bulb counterclockwise and pull it out of the socket.
3. Push a new bulb into the socket and turn it clockwise to lock the bulb in place.
4. Replace bulb socket in gauge and replace the rear dashboard housing.

## Panel light bulb replacement

Panel light bulbs are mounted under the dashboard panel in sockets and serve to illuminate control switches such as the heating and A/C switches.

1. To replace a panel light bulb, the rear dashboard housing must be removed.
2. Push and turn the bulb counterclockwise, then pull it out of the socket.
3. Place the new bulb into the socket, then push and turn clockwise to lock in position.
4. Replace the rear dashboard housing.

## Front and rear stepwell lights

Rear and front stepwell lights are illuminated when the door opening system is activated. The light bulbs are accessible after removal of the light lens which is held to the housing with two screws.

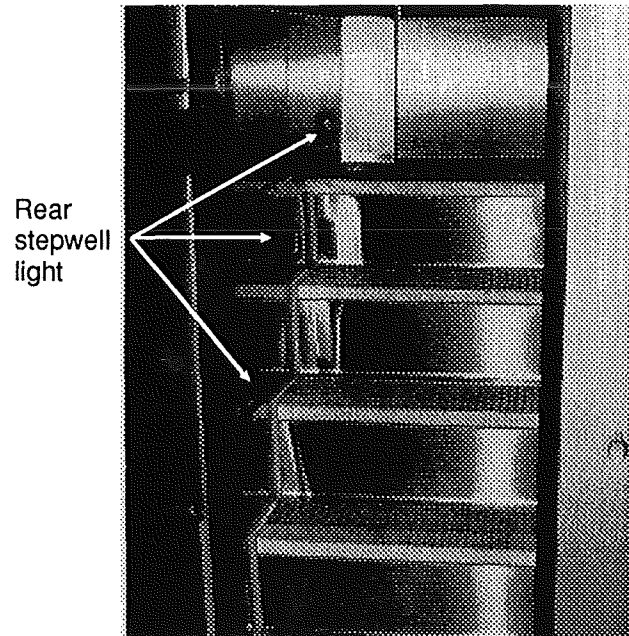

FIG. 46

MA5-1546.JPG

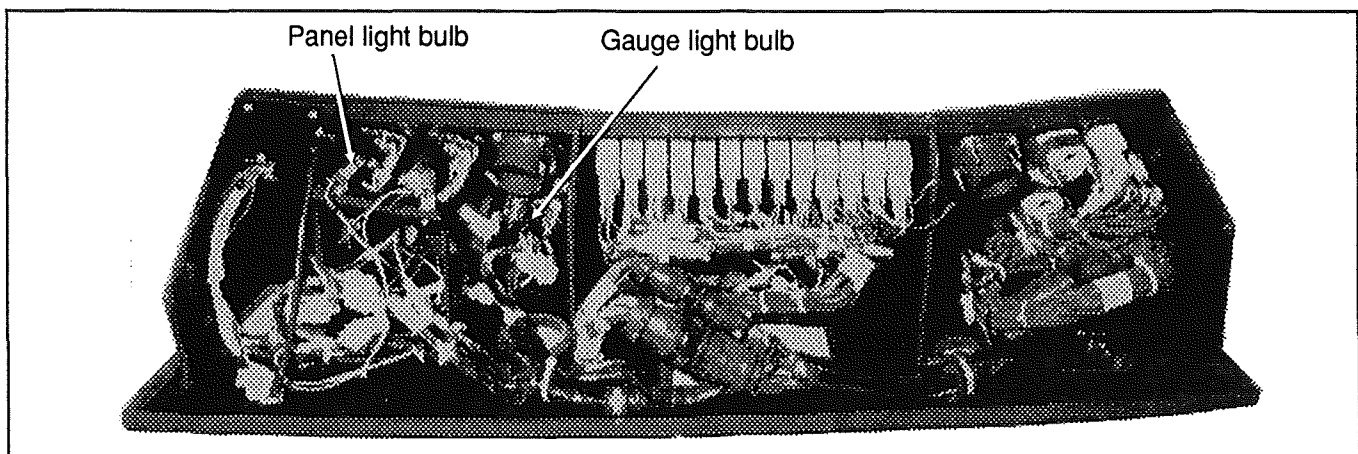

FIG. 45 - Back of dashboard with rear housing removed

MA5-1545.JPG

## Removal and replacement

1. With the light lens removed, push and turn the bulb counterclockwise, then pull it out of the socket.
2. Place the new bulb into the socket, then push and turn clockwise to lock in position.
3. Place the light lens and screw it in place.

## Engine compartment light

Three (3) engine compartment lights controlled by a microswitch upon opening of the engine door, are provided in the engine compartment, two on the L.H. side and one on the R.H. side. The bulbs are accessible after removing the light lens which is attached to the housing with a retaining ring and two screws.

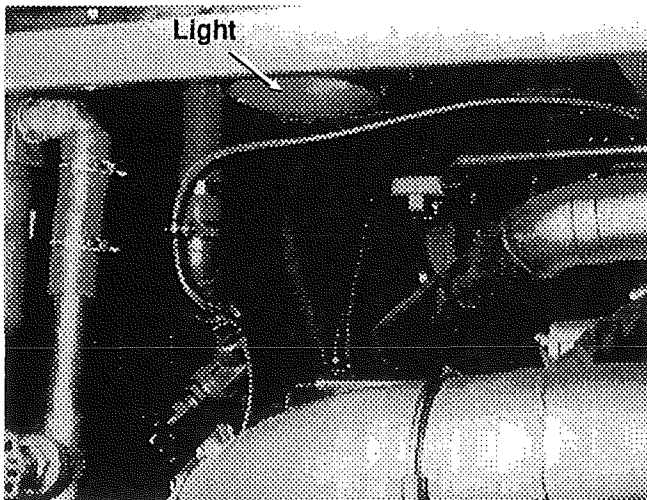

FIG. 47 - Engine compartment light

MA5-1547.IMG

## Removal and replacement

1. Remove the retaining ring of lens by unscrewing the two screws.
2. Push and turn the defective bulb counterclockwise, then pull it out of the socket.
3. Place the new bulb into the socket, then push and turn clockwise to lock bulb in position.
4. Place the lens, then the retaining ring and screw it in place.

## Fluorescent lighting system

The interior of vehicle is lighted by two types of fluorescent tube lamps installed on parcel racks.

The aisle bulb lights are located on front of parcel racks, while fluorescent lights for general and in-station lighting are located under the parcel racks. A dual power system is available for this lighting either from the 24 volt vehicle power supply or from a 110 volt outlet supply. In order to save batteries during extended periods of in-station lighting, no current is drawn from the batteries as soon as the 110 volt circuit is connected.

Moreover, adjustable reading lamps are installed under parcel racks for passenger accommodation.

## Removal and replacement of aisle fluorescent light

1. Remove the front lens by unscrewing the four (4) "Phillips" side screws (two each side), then the lens.
2. Pull out the fluorescent from its base.
3. Place a new fluorescent and push on until the proper position is reached.
4. Replace front lens and screw it.

## Removal and replacement of fluorescent light

1. Push on the screen lens of fluorescent in order to unsnap it.
2. Rotate and pull out the fluorescent tube from its socket.
3. Place the new fluorescent tube and rotate the tube to secure it in its socket.

## Removal and replacement of reading lamp bulb

1. Slide lightly the reading lamp and pull in order to unsnap it.
2. Turn over the reading lamp and unscrew both screws of the retaining socket support.
3. Push and turn bulb counterclockwise, then pull it out of the socket.
4. Place new bulb into the socket, then push and turn clockwise to lock bulb in position.
5. Place retaining socket support and screw in place.
6. Place the reading lamp to its position and press until it snaps.

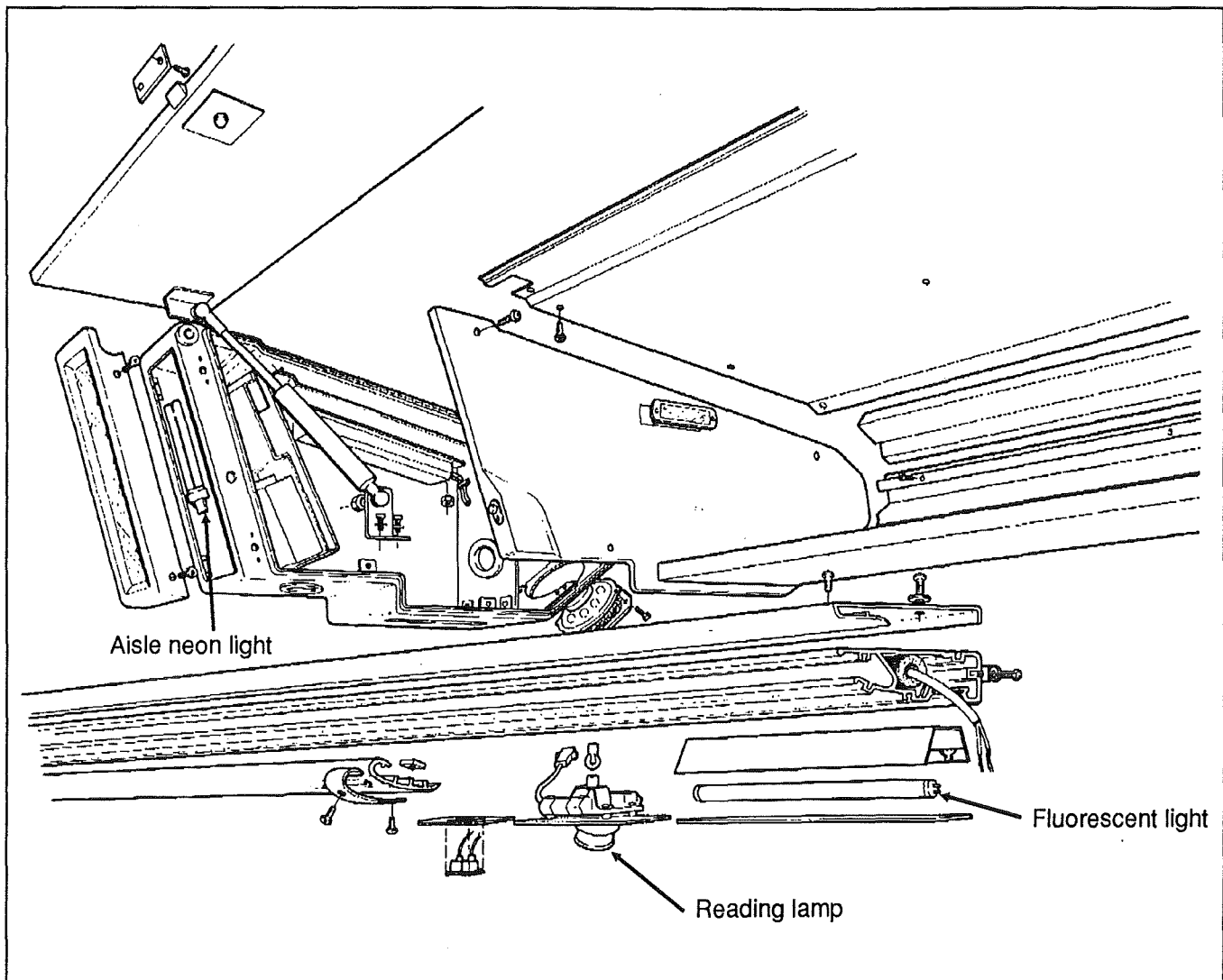

FIG. 48

MA5-1548.IMG

## Dome lights

Two dome lights are installed over the stepwell and the driver in driver's compartment, and one over the rear stepwell. These lights are frequently used for nighttime operation when passengers board or leave coach.

## Removal and replacement

1. Unsnap the lens and remove it.
2. Push and turn bulb counterclockwise, then pull it out of the socket.
3. Place the new bulb, push and turn clockwise until it locks in position.
4. Replace the lens and snap it back in place.

## Light bulb data

When replacing a light bulb, special attention must be paid to the voltage rating.

**NOTE:** Note that all exterior lights are 12 volts and that all interior lighting are 24 volts, except for the "Check engine" and "Stop engine" tell-tale lights, and the lavatory ballast.

## SPECIFICATIONS

### BATTERY

Make	Delco-Remy
Model	1150
Type	Maintenance-free
Terminal type	Top Stud
Group size	.31
Volts	.12
Load test amperage*	290
Reserve capacity (minutes)	180
Cold cranking (in amps)	
- At 0 °F (-18 °C)	625 (each battery)
- At -20 °F (-29 °C)	490 (each battery)
Maximum dimensions (inches/mm)	
- Length (including flange)	13.0/330,2
- Width	6.8/172,7
- Height (including top posts)	9.4/238,8
- Approximate weight (lbs/kg)	60/27,2

\* Battery tester cable clamps should be between terminal nuts and lead pads of terminals. If not possible, load value should be 210 amperes.

### TORQUE SPECIFICATIONS

Battery cable to post	10-15 ft.lbs (13-20 N.m)
Battery cover	45-50 in.lbs (5-6 N.m)

### ALTERNATOR

Make	Delco-Remy
Prévost Number	.56-1723
Model Number	.1117702
Series	.50 DN
Type	600
Field current at 80 °F (27 °C)	
- Amperes	.7.2 - 8.0
- Volts	.24
Hot output	
- Amperes	270 at 80 °F (27 °C) ambient
- Volts	28
- Approximate rpm	3000
Ground	Negative

**REGULATOR**

Make . . . . . Delco-Remy  
Prévost Number . . . . . 56-0030  
Model Number . . . . . 1118447  
Type . . . . . Transistor  
Voltage adjustment . . . . . External screw

**STARTING MOTOR**

Make . . . . . Delco-Remy  
Model Number . . . . . 1990269  
Series . . . . . 50 MT  
Type . . . . . 400  
Rotation (viewing drive end) . . . . . CW  
Brush tension . . . . . 5 lbs (2,2 kg) Min.  
Voltage . . . . . 24  
No-load test  
- Volts . . . . . 23  
- Min. current draw . . . . . 60 amperes  
- Max. current draw . . . . . 90 amperes  
- Min. rpm . . . . . 7000 rpm

**STARTING MOTOR SOLENOID**

Make . . . . . Delco-Remy  
Model Number . . . . . 1115557  
Current Draw 80 °F (27 °C)  
- Hold-in winding . . . . . 7.35 - 8.2 amps  
- Pull-in winding . . . . . 48 - 54.5 amps  
Volts . . . . . 24

**BATTERY EQUALIZER**

Make . . . . . Vanner  
Prévost Number . . . . . 56-1016  
Model . . . . . 60-50A  
Amperes . . . . . 50 amps

**LIGHT BULB DATA**

Trade number	Application	Watts or candle power	Volts	Qty
H4651	Hi-beam, headlamp	50 W	12	2
H4656	Lo-beam, headlamp	35 W	12	2
H-3	Docking & cornering lamp	55 W	12	4
H-3	Fog lamp	55 W	12	2
93-0266	Licence plate light	----	12	1
1893	Side directional light	----	12	12
1893	Side marker light	----	12	12
1893	Clearance light	----	12	28
1157 NA	Front directional light	32/3	12	2
Hella	Rear directional light	32	12	4
Hella	Stop light	32	12	4
Hella	Back-up light	32	12	4
Hella	Center stop light	32	12	1
Hella	Tail light	10W	12	4
HR464	Kneeling indicator light	----	24	1
3796	Check engine telltale lamp	2W	12	1
3796	Stop engine telltale lamp	2W	12	1
623	Compartment light	6	24	64
623	Engine compartment light	6	24	6
623	Step light (front & rear)	6	24	7
623	Lavatory light	6	24	1
1820	Baggage compartment light	1.6	24	20
1820	Instrument light - 1/unit	1.6	24	AR
Hella	Dome light	10W	24	4
Hella	Rear entrance ceiling light	10W	24	2
1843	Emergency exit lamp	0.2	24	32
456	Lavatory occupied lamp	2	24	2
456	Watch your step lamp	2	24	4
1251	Aisle lamp	3	24	9
2741	Switch light - 1/unit	1W	24	AR
3797	Indicator light - 1/unit	2W	24	AR
961-4140	Reading lamp	8W	24	76
F15T8 CW	Lighting fluorescent	15W	----	34
F15T8 CW	Lavatory fluorescent	15W	----	2
F30T8 CW4	Destination sign fluorescent	20W	----	1
PL7	Parcel rack front Neon	7W	----	22









# 16

# HEATING AND AIR CONDITIONING

---

## CONTENTS OF THIS SECTION

GENERAL DESCRIPTION . . . . .	16-1
AIR CIRCULATION . . . . .	16-1
SYSTEM OPERATION . . . . .	16-3
CONTROL . . . . .	16-3
DIAGNOSIS OF MAIN HVAC UNIT PROBLEMS . . . . .	16-5
MAIN HVAC UNIT TROUBLESHOOTING GUIDE . . . . .	16-7
MAIN HVAC UNITS . . . . .	16-12
BLOWER MOTOR . . . . .	16-13
AIR CONDITIONING SYSTEM . . . . .	16-15
A/C SYSTEM COMPONENTS . . . . .	16-18
HUMIDISTAT . . . . .	16-22
CONDENSER FAN HYDRAULIC SYSTEM . . . . .	16-22
HEATING SYSTEM . . . . .	16-26
HEATING SYSTEM COMPONENTS . . . . .	16-29
SPECIFICATIONS . . . . .	16-36



# 16 HEATING AND AIR CONDITIONING

## GENERAL DESCRIPTION

The coach interior is pressurized by its Heating, Ventilation, Air Conditioning (HVAC) units. Air flow and controls divide the vehicle in three interrelated zones:

- Driver's zone
- Front section
- Rear section

The interior of vehicle should always be slightly pressurized to prevent dust and moisture from entering vehicle. Each section has its own fresh air, returning air and discharge air ducting. The exhaust is mainly done through the lavatory ventilator and through normal air-tightness losses (see fig. 1).

## AIR CIRCULATION

### Driver's zone

Fresh air is taken from a plenum behind the bumper and enters the mixing box through an adjustable damper. Returning air is taken through a front dash panel into the mixing box. The "Driver A/C-heating air recirculation" control is located on the R.H. dashboard control panel. Mixed air goes through cooling and heating coils, a fan and a discharge duct.

The right discharge duct will defrost about 2/3 of the lower windshield. The left discharge duct will defrost the rest of the lower windshield in front of the driver. The driver can also with the "A/C-heating main windshield defroster" control divert this air flow to the console, from which he can direct vent to his feet, knees and/or breast (see fig. 2).

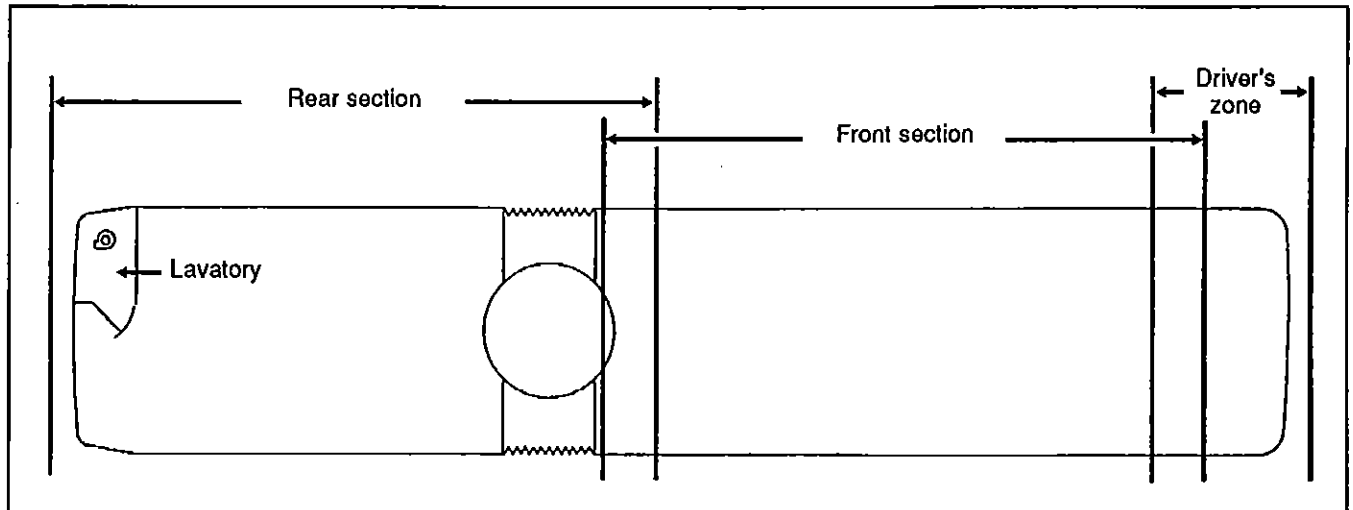

FIG. 1 - Heating, ventilation, air conditioning (HVAC) zones

MA5-1601.IMG

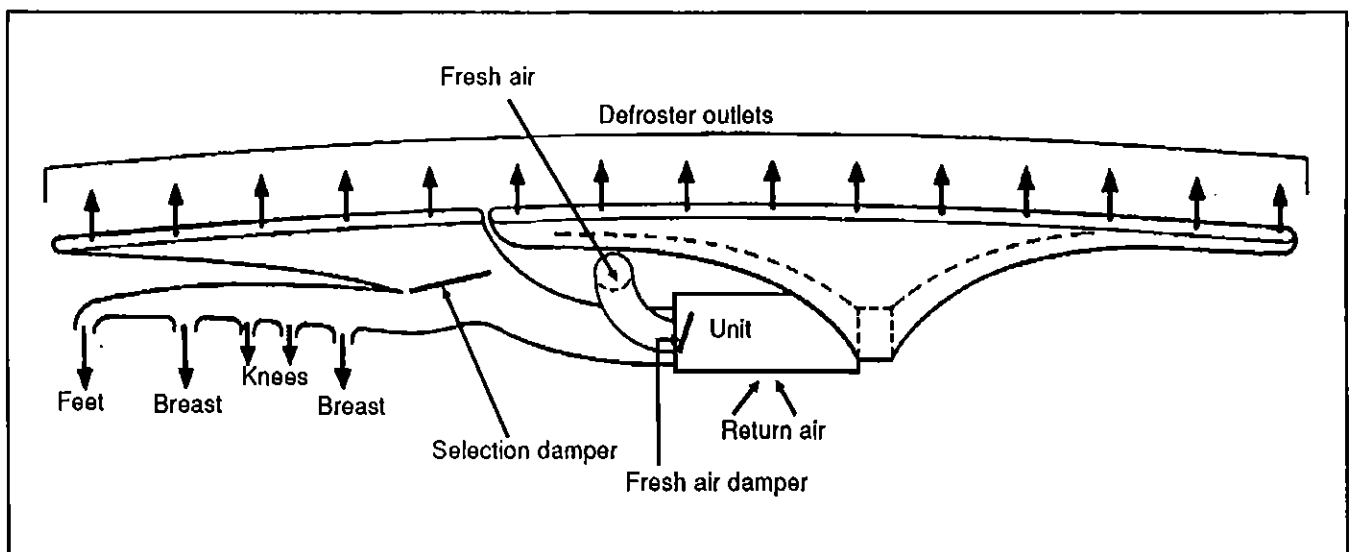

FIG. 2 - Driver's air circulation

MA5-1602.IMG

### Front zone

Fresh air is taken from the left side through a two position damper. The pneumatically controlled damper can be fully opened for normal operation or partially closed for extreme weather or highly polluted areas; the "Fresh air damper" switch, located on the R.H. side lower control panel, controls both front and rear dampers simultaneously.

Return air is drawn from two underseat air return boxes and through an entrance step riser (see fig. 3).

Mixed air then passes through cooling and heating coils and goes to two separate blowers just underneath the inside ventilation duct; then, it follows the usual path in the ventilation duct, between the walls and exhaust at the bottom of the windows.

### Rear zone

The HVAC unit of rear section is identical to the front section unit. Air flow follows about the same path as in the front zone, except that the returning air is drawn from the ventilation duct inlets, located on both sides of the floor near the articulation and in the step riser near the lavatory (see fig. 3). Part of the air is also discharged in the articulation area.

In this zone, there is also an exhaust ventilator in the lavatory that serves two purposes. First, it eliminates odors and in the second place, heats or cools the lavatory with the vehicle ambient air.

The ventilator acts as the main exhaust for the whole vehicle. Thus, if a smoking compartment is desired, we recommend the use of the rear section.

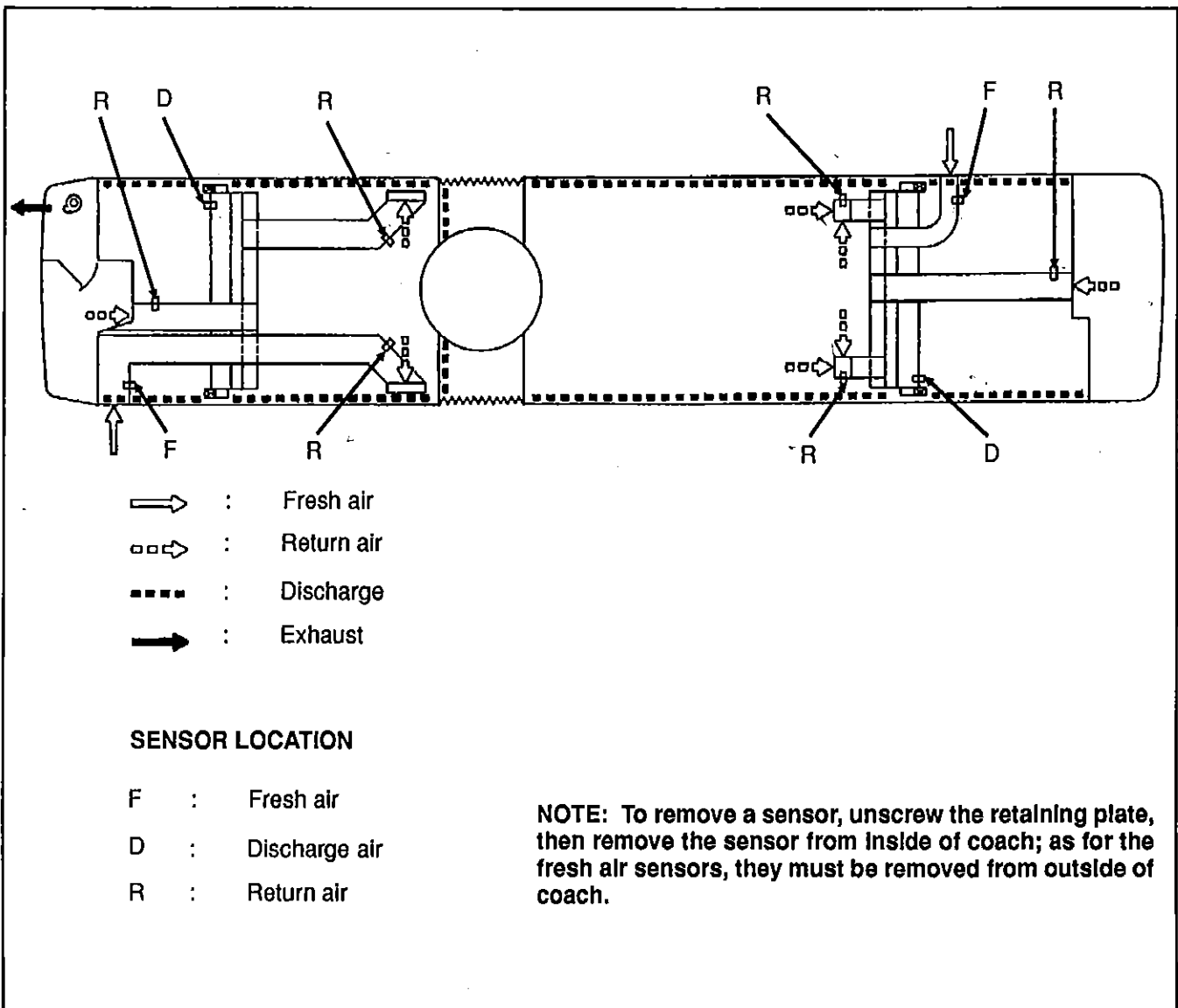

FIG. 3 - Main system air circulation

MAS-1603.IMG

## SYSTEM OPERATION

The "Passenger A/C-heating" switch, located on the R.H. side lower control panel, operates the A/C-heating and ventilation systems (HVAC) in both front and rear zones simultaneously.

In addition, the "A/C-heating temperature" controls, located on the R.H. side dashboard control panel, enable the independent selection of the temperature in each of the three zones. In case of A/C system failure, switch off "Passenger A/C-heating" and push to the "On" position the "Passenger ventilation" switch, located on the R.H. side lower control panel to activate ventilation only. Furthermore, ventilation may be increased by opening roof mounted emergency vents.

Each main unit of the HVAC system is equipped with two (2) independent fan motors, which are protected by a manual reset 40 amp breaker. The feeder circuit of these two breakers is protected by a 90 amp breaker, which is located in the "Engine" junction box.

To operate air conditioning system when vehicle is stationary, engine should run at fast idle. During operation of air conditioning system, windows should be kept closed and doors not left opened longer than necessary. In order to prevent battery discharge, HVAC system will

not operate if vehicle charging system is not working properly.

## CONTROL

### Main system

Temperature control of each main system is connected to a Honeywell W973B control module (see fig. 4). Air temperature is picked up by three (3) identical sensors, each one located in one of the three (3) returning air ducts, and by another sensor located in the ventilation duct (see fig. 3). As shown on figure 6, the sensors are series-parallel connected. The printed circuit board T7067B (see fig. 5) detects the sensor signal and then compares it with the driver's setpoint (A/C-heating control).

This will result in a voltage range (see fig. 7) for the control module W973B. At this point, a fresh air sensor located in the fresh air damper on side of vehicle, can modify this range to anticipate any major change in the outside temperature. Afterwards, the control module W973B will select the appropriate staging according to the actual conditions.

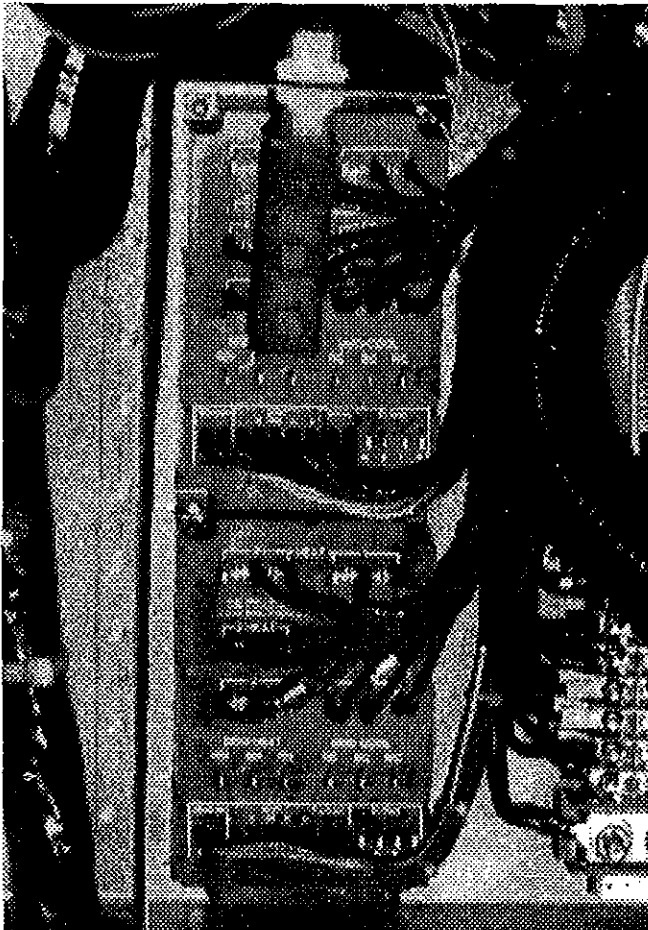

FIG. 4 - Control modules W973B

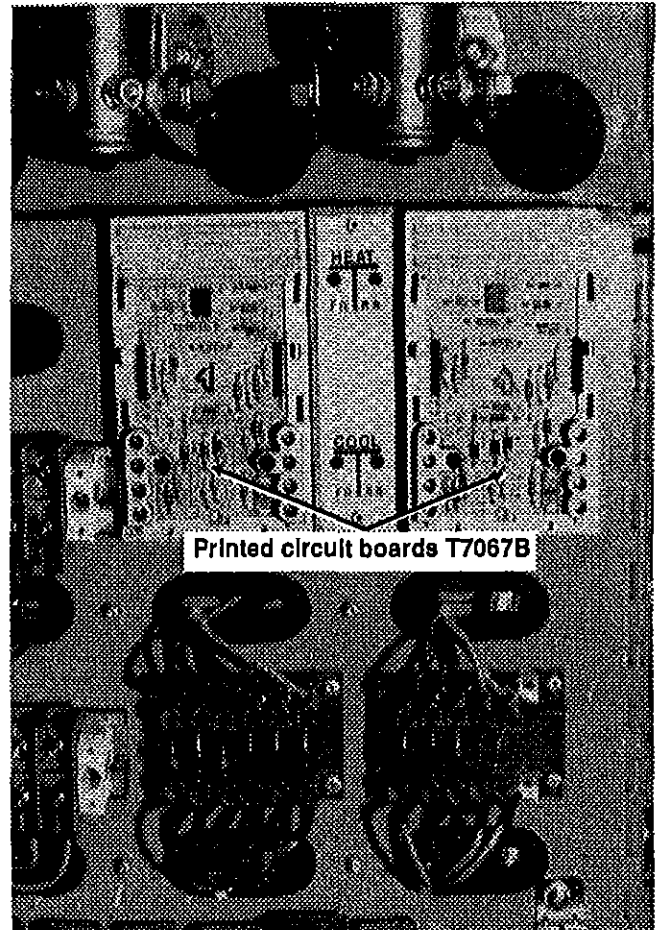

FIG. 5

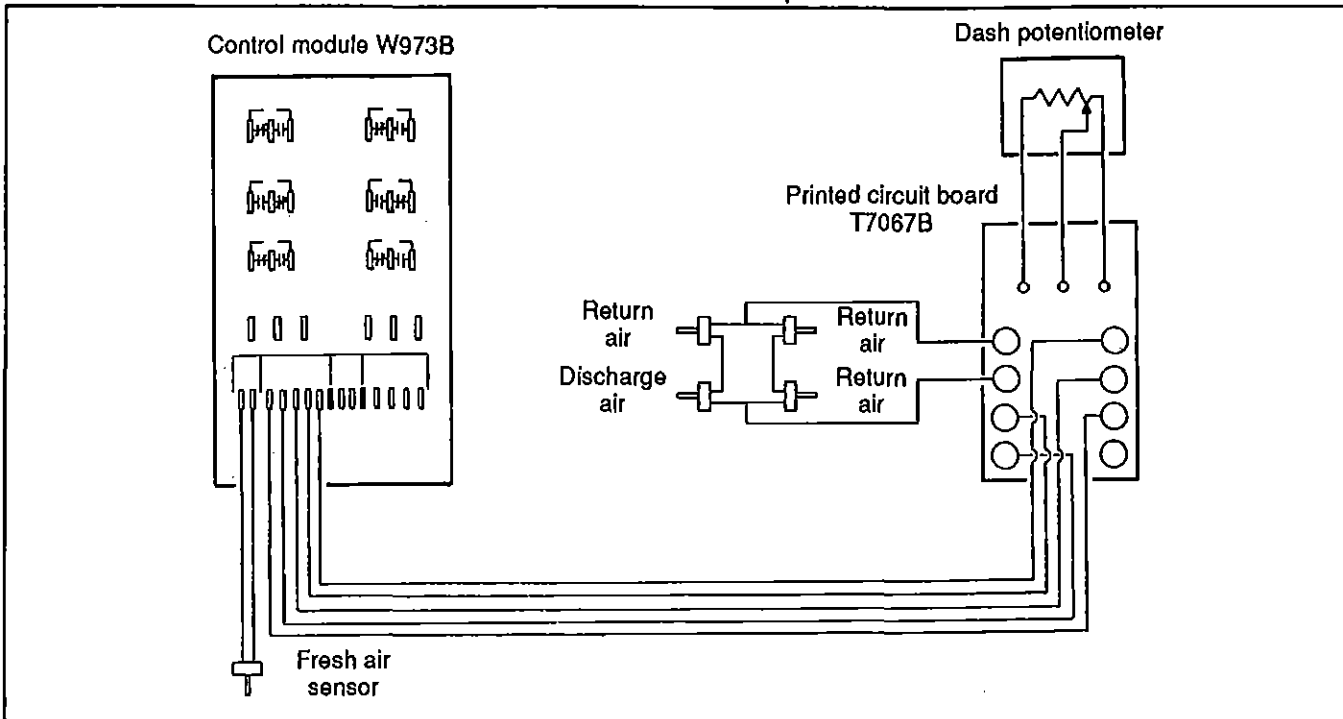

FIG. 6

MA5-1605JMG

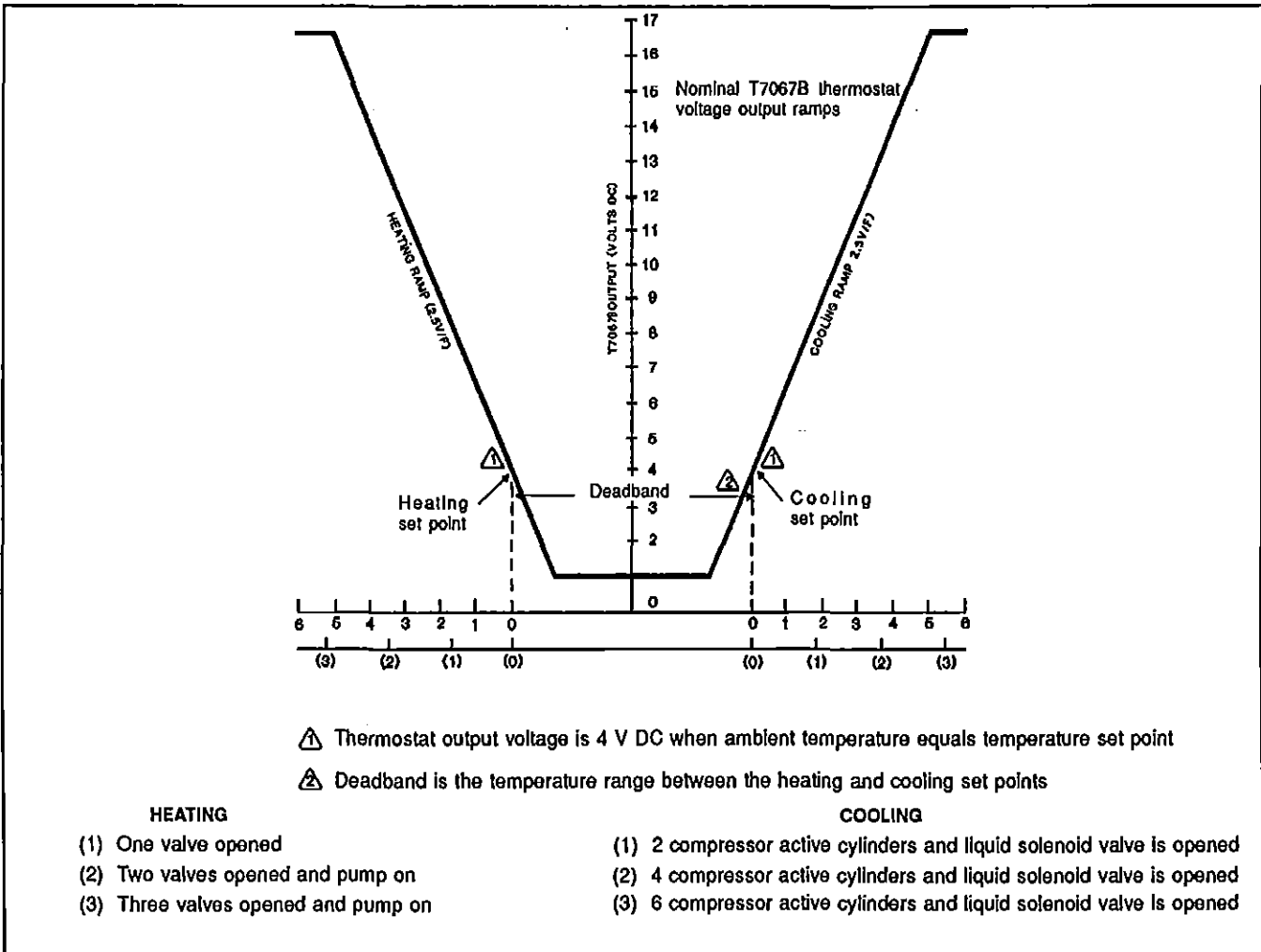

FIG. 7 - T7067B output voltage ramps

MA5-1607,IMG

In the heating mode, the stages will be provided by three (3) paralleled water solenoid valves (normally-closed) and a water recirculating pump (see fig. 8). Staging will be defined as follows:

STAGE 1 : 1 water solenoid valve is opened, thus activated

STAGE 2 : 2 water solenoid valves are opened and water recirculating pump is activated

STAGE 3 : 3 water solenoid valves are opened and water recirculating pump is activated

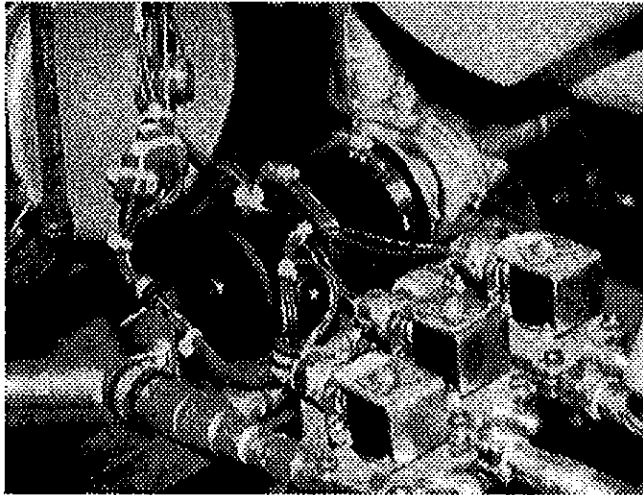

FIG. 8 - Three (3) paralleled water solenoid valves

In the cooling mode, the number of active cylinders in the compressor will vary according to the stages by means of electric unloaders. Staging may be defined as follows:

STAGE 0 : Compressor clutch is disengaged

STAGE 1 : 2 active cylinders and refrigerant solenoid valve is closed

STAGE 2 : 4 active cylinders and refrigerant solenoid valve is opened

STAGE 3 : 6 active cylinders and refrigerant solenoid valve is opened

### Driver's system

The temperature control in the driver's system is provided by the "Driver A/C-heating temperature" control, and by a thermistor sensor located under dashboard. At extreme clockwise position, the temperature control will deliver full heat without any control.

The fan speed will be set by the position of the "Driver A/C-heating ventilation speed" control which has two functions. The clicking noise produced while turning the control, activates the heating or A/C system according to the "Driver A/C-heating temperature" control position, which also acts as a potentiometer. Consequently, it is possible to gradually increase speed of fan motor from 25% to maximum speed. An electronic module, mounted on the HVAC unit, analyses the value sent by the potentiometer, and thus sets the motor speed. This installation ensures economical operation, and a wide speed range.

The driver's A/C and heating system piping is paralleled with the main HVAC unit pipings. The three units use the same refrigerant and coolant, and are linked to the same condenser and compressor, even if they are individually controlled (with the exception of the humidistat which controls the two main units). It requires at least one main unit to engage the compressor magnetic clutch. Consequently, the driver's unit cannot be operated alone.

### DIAGNOSIS OF MAIN HVAC UNIT PROBLEMS

Troubleshooting the HVAC system is made easier with the LEDs (light-emitting diodes) integrated in the system, and acting as indicator lights.

Each main HVAC unit is equipped with three (3) LEDs to indicate the heating mode, and are located as follows:

One (1) red LED located on printed circuit board T7067B and identified "Heat" (see fig. 9). The printed circuit board picks up the sensor signal, and compares it with the setpoint established by the driver. After analysis, a voltage signal, which value is proportional to the analysis result (sensor vs driver's setpoint), is transmitted to the control module W973B. The LED on the printed circuit board will be illuminated according to the voltage value, i.e. LED may not be illuminated at first, and then may gradually reach its maximum brightness or vice versa.

Two (2) other red LEDs connected in parallel are located as follows:

One LED is located on the R.H. console under the thermometer, while the other one is located between the two (2) printed circuit boards T7067B (see fig. 9). The two (2) LEDs are connected in parallel and operate simultaneously; unlike the other LED, they are illuminated or not ("On" or "Off"). Their function is to indicate the output of the control module W973B.



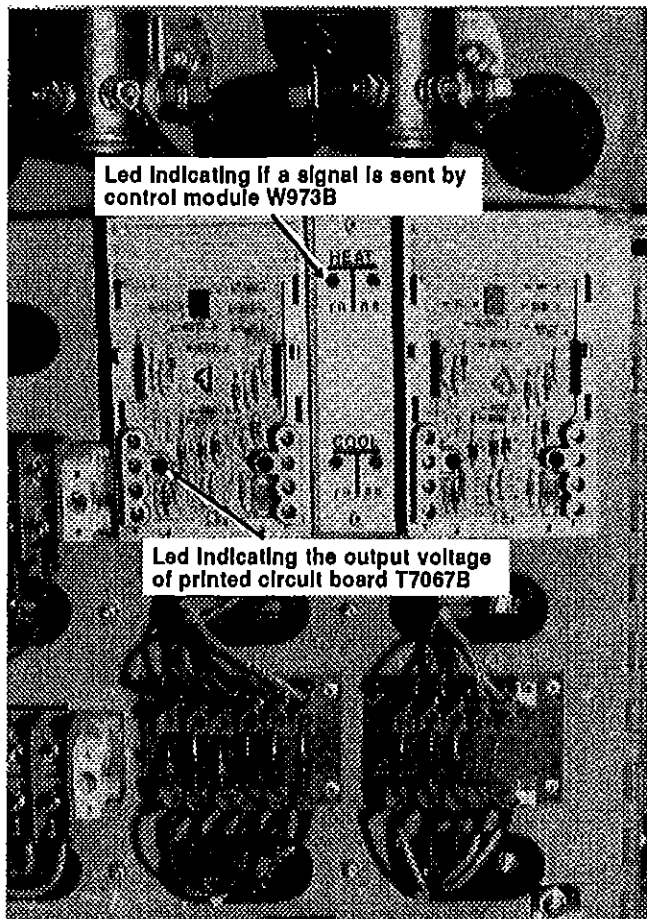

FIG. 9

When the humidistat requests the operation of the A/C system to dry ambient air inside of vehicle, the two (2) green LEDs will illuminate to indicate the operation of this system. However, the "Cool" red LED on the printed circuit board will not illuminate, because the humidistat control bypasses printed circuit board T7067B. It is thus normal for the driver who requests heat by means of the "A/C-temperature" switch, that the red and green LEDs illuminate simultaneously. This corresponds to the operation of the heating system to heat vehicle, and to the operation of the A/C system to dry air.

The control module W973B reads the voltage from the printed circuit board, and as soon as the voltage reaches 4.6 volts, the control module W973B sends a signal to activate stage 1 of the heating system, i.e. one solenoid valve is activated. At this stage, the two (2) red LEDs will illuminate to indicate that W973B has sent a signal to activate heating system. If the other stages are activated, the two (2) LEDs will remain illuminated.

The red LED on the R.H. console advises the driver that the heating system is operating. The red LED, located between the two printed circuit boards, enables the technician to quickly diagnose the problem.

As for the A/C mode, it is almost the same installation, except that the red LED on printed circuit board T7067B is identified "Cool". Its operation is, however, identical.

The significant difference lies in the fact that the two (2) other LEDs connected in parallel are green. One (1) LED is located on the R.H. console for the driver, and the other one between the two printed circuit boards for diagnostic purposes. These two (2) LEDs indicate the operation of the A/C system.

## MAIN HVAC UNIT TROUBLESHOOTING GUIDE

System does not operate with the "Passenger A/C- heating" switch to the "On" position

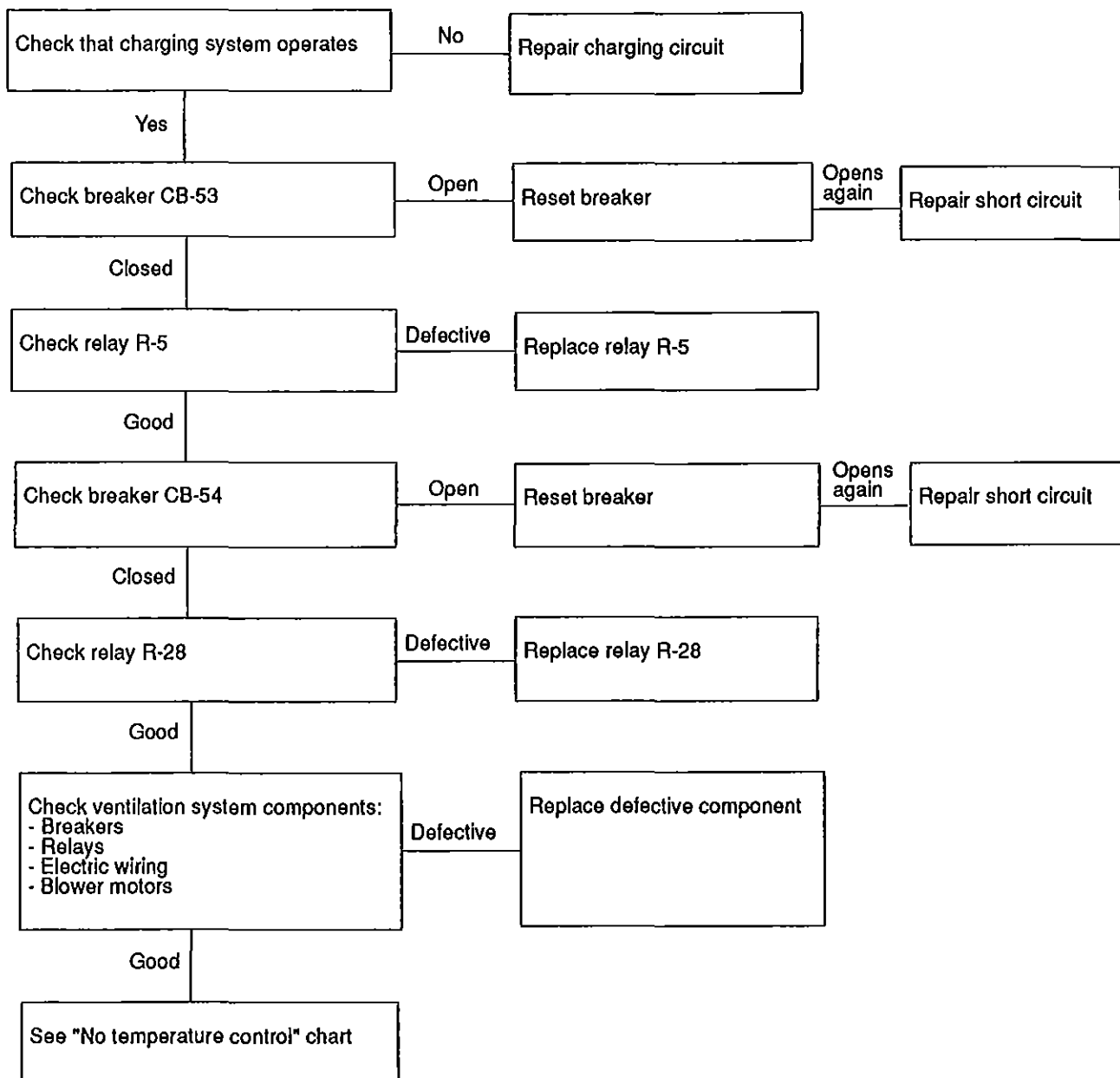

## No temperature control chart

Ventilation operates, but there is *"no temperature control"*

Turn *"A/C-heating temperature"* control to extreme clockwise or counterclockwise position (warm or cold)

Set humidistat to its maximum clockwise position to inhibit operation of A/C system which could alter data.

Check if LED, located on printed circuit board T7067B, is very bright when it indicates the selected mode.

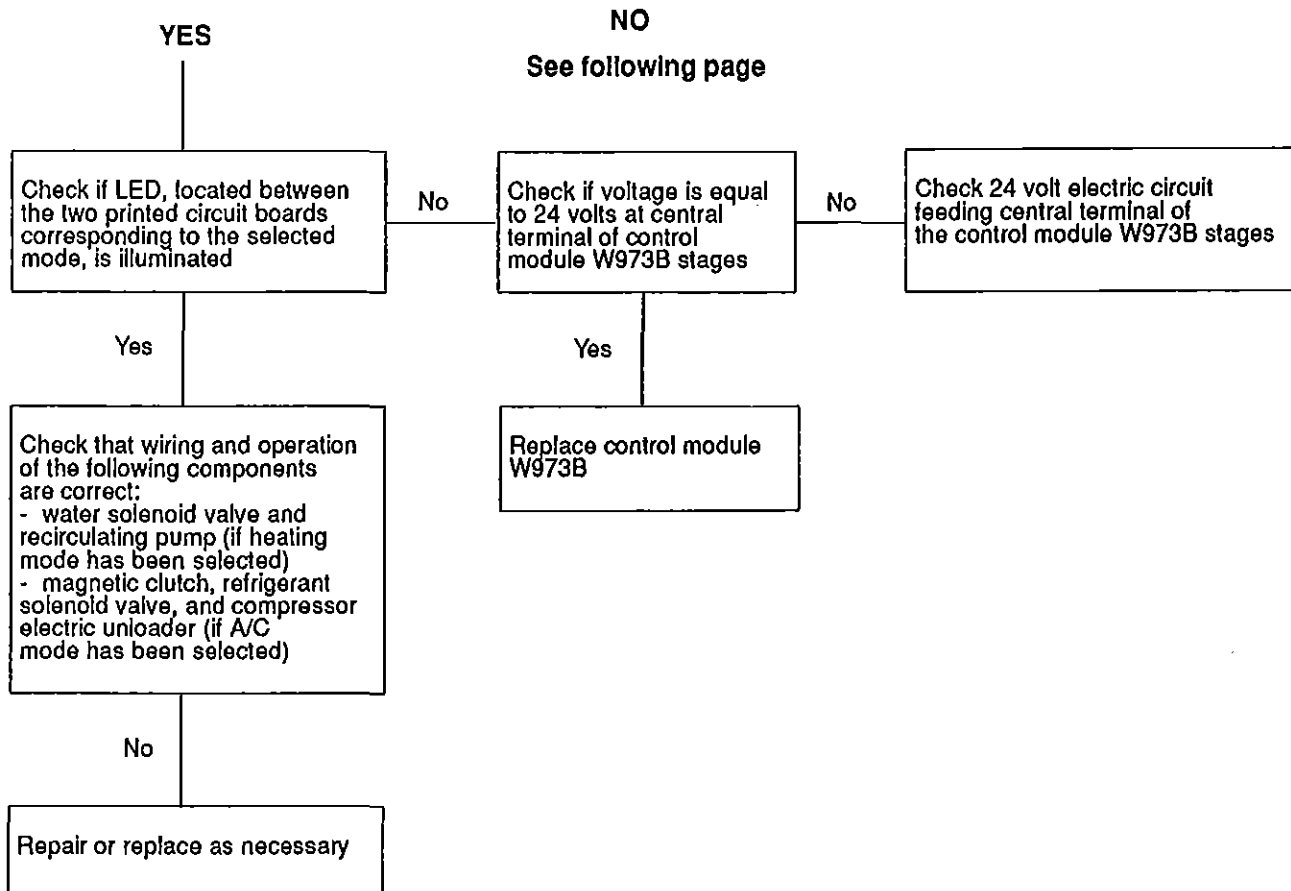

The LED, located <sup>ON</sup> ~~between~~ printed circuit board T7067B, is dimmed or not illuminated

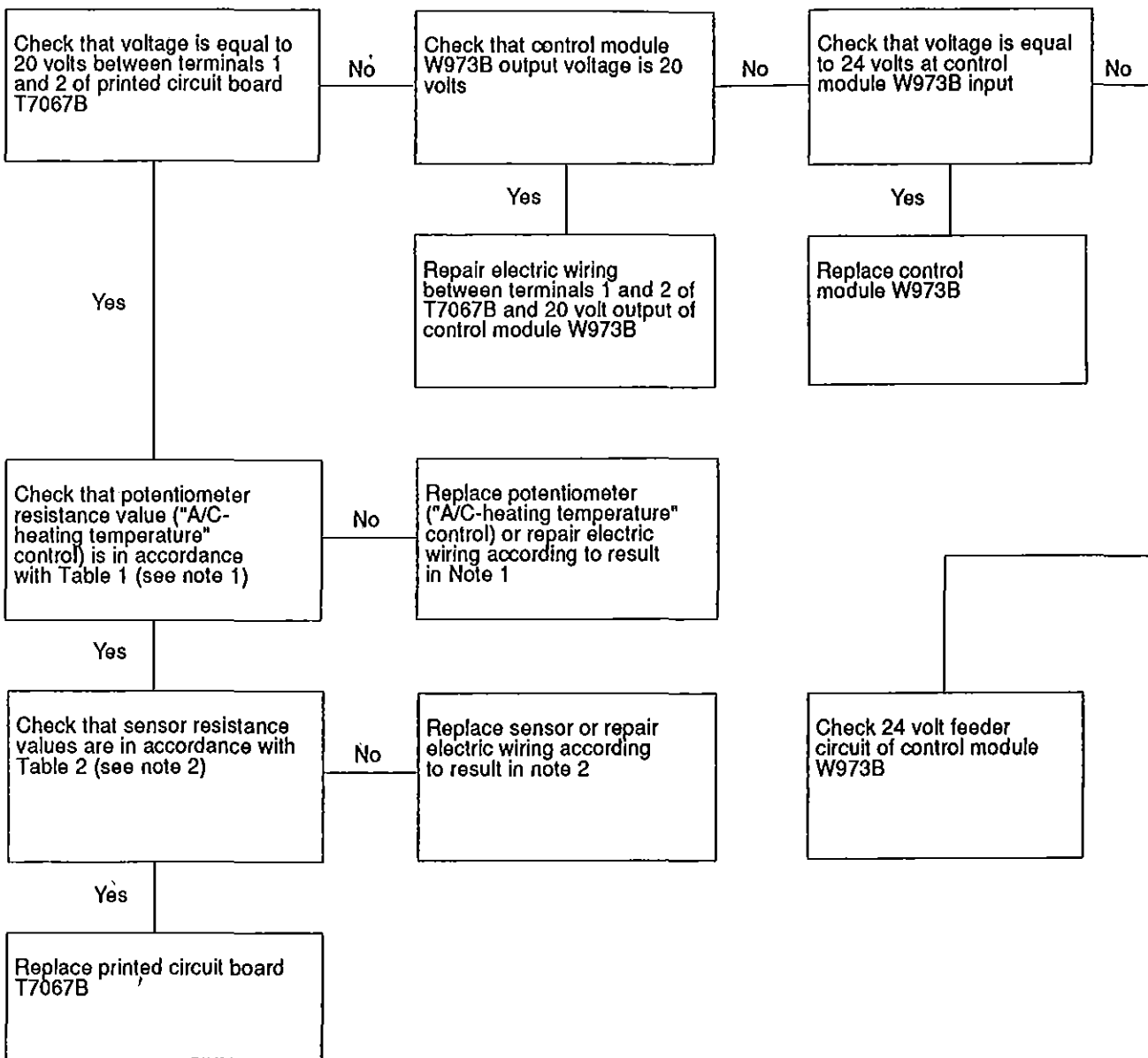

**Note 1: Checking potentiometer resistance value**

Disconnect 2 pin connector located inside "Engine" junction box on back of printed circuit board T7067B. Locate the two (2) female terminals (which were connected to male terminals P1 and P2), and using an ohmmeter connected according to the indications given in Table 1, check if readings match with data of Table 1. At item P3, place the ohmmeter probe on head of screw #1 of printed circuit board.

**NOTE:** Readings may be slightly higher than those in Table 1 due to the length of the wires routed between printed circuit board T7067B and the potentiometer.

If reading does not match, check if potentiometer or wiring between potentiometer and printed circuit board is defective. In such case, proceed as follows:

Disconnect connector C356 under dashboard, right behind potentiometer. Locate terminals corresponding to the green (P3), red (P1), and brown (P2) wires on male connector. Using an ohmmeter connected according to the indications given in Table 1, check if readings match with data of Table 1.

If readings match, trouble is located in wiring between printed circuit board T7067B and connector C356. If reading does not match, potentiometer is defective.

**CIRCUIT DIAGRAM OF DUAL POTENTIOMETER (A/C-HEATING TEMPERATURE CONTROL)**

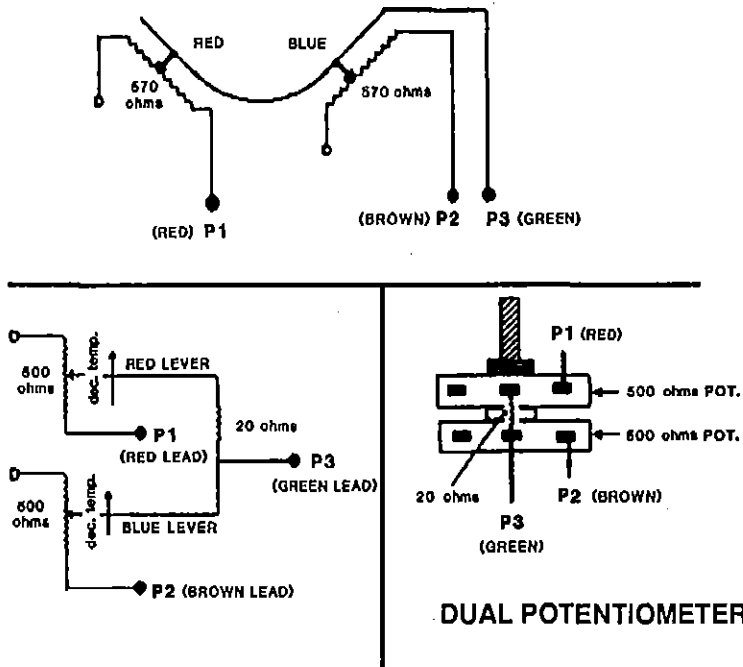

CONNECTIONS		POTENTIOMETER RESISTANCE			
		P3 / P1		P3 / P2	P2 / P1
heating ↓ Max.	Mln.	534 ohms	19 ohms	515 ohms	1046 ohms
	Max.	493	20	473	964
cooling ↑ Mln.	Mln.	426	24	402	825
	Max.	352 ohms	27 ohms	325 ohms	673 ohms
	Mln.	284	32	252	532
	Max.	210	34	176	383
	Mln.	143 ohms	39 ohms	104 ohms	243 ohms
	Max.	76	45	31	103

TABLE 1

MA5-16T1,IMG

**Note 2: Checking the sensor resistance values**

Remove the eight (8) screws (#1 to #8) on the printed circuit board and move it away from its support, which holds the junction terminals. Locate terminals #6 and #7 on support, and using an ohmmeter, note the reading between these two terminals. (The board is moved away from its support to isolate the sensor electric circuit from the printed circuit board). Compare reading with data of Table 2 given in the "Recirculating Air Sensor" curve. Temperature at the bottom of Table 2 is the temperature picked up by the sensor at the time of verification.

Reading between terminals 6 and 7 corresponds to the total resistance of the four (4) series-paralleled sensors. Thus, if reading does not match with Table 2, check if problem is located in sensor or wiring.

**Testing each sensor**

Remove screen over the air return box inside the vehicle (refer to fig. 3 for sensor location), disconnect the sensor connector, and with an ohmmeter, note sensor reading. Compare reading with data of Table 2 given in the "Recirculated Air Sensor" curve. The four (4) sensor curve is again used, since each sensor, taken individually, has the same resistance than the four (4) series-paralleled sensors taken together.

Repeat this procedure for each of the four (4) sensors in order to locate defective unit.

If all sensors check good, the problem is located in wiring, between terminals 6 and 7 and the sensors.

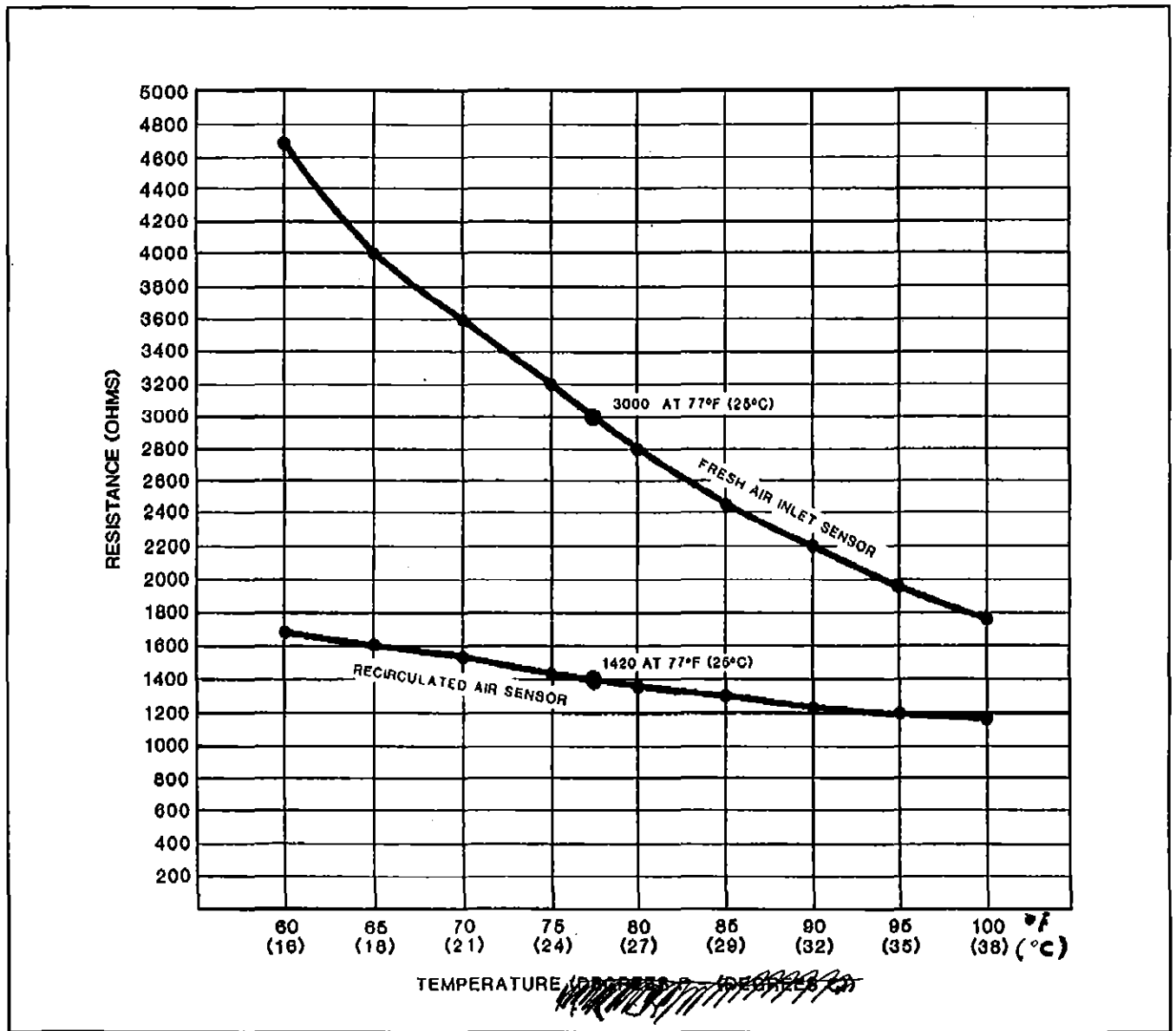

TABLE 2 - Resistance range according to ambient temperature sensors

MAS-16T2JMG

## Fresh air inlet sensor

### Description

Each main HVAC unit is provided with a fresh air sensor, located in the fresh air damper. The fresh air sensor consists in a thermistor sensing element mounted in a tubular probe. The negative temperature coefficient characteristic of the thermistor element causes its resistance to decrease as the sampled air temperature increases. The fresh air sensor provides heating and cooling anticipation to the system at a sensitivity ratio of 25:1. In other words, a 25 °F (14 °C) increase in fresh air inlet temperature corresponds to a 1 °F (0,6 °C) decrease in set temperature. Thus, if sensor is short-circuited or in an open circuit condition, the control system will be slightly affected, i.e. the temperature inside of vehicle will be about 2 or 3 °F (1 or 2 °C) lower or higher than the temperature selected by the driver with the "A/C-heating temperature" control.

### Checkout

1. Set the ohmmeter scale to R X 1000.
2. Disconnect terminal T1 connector from the sensor located on control module W973B.
3. Connect a wire of the ohmmeter to terminal T of control module W973B, and the other wire of the ohmmeter to the loose wire of sensor.
4. The ohmmeter reading will vary according to the temperature picked up by the sensor. The fresh air inlet sensor resistance must vary between 1600 and 4800 ohms. Refer to Table 2 for the resistance readings at different temperatures. If reading does not match with the data of Table 2, replace fresh air inlet sensor.

## MAIN HVAC UNITS

### Description

Two main identical HVAC units are provided, and are respectively located in the first baggage compartment and in the last baggage compartment. Each main unit contains:

- 2 electric blower motors
- 2 forty (40) amp circuit breakers
- 2 heater cores
- 2 evaporators
- 2 thermostatic expansion valves
- 2 air filters
- 1 temperature sensor

The blower motor draws air through an air filter, then through the evaporator coil where it is cooled and dehumidified; afterwards, it goes through the heater core where the air temperature is raised to the temperature level as determined by the "A/C-heating temperature" control.

### Maintenance

No special maintenance is required on a main HVAC unit, with the exception of cleaning the two (2) air filters every 10,000 miles (16 000 km) or as required according to operating conditions, using the following procedure:

1. Unscrew the six 1/4 turn screws retaining the access panel.
2. Pull on the filter and discard it (see fig. 10).
3. Place a new filter with the arrow pointing in the same direction of air flow (**down**).
4. Reinstall the access panel and secure with the six 1/4 turn screws.
5. Repeat the same procedure for the other filter located at the other end of the unit.

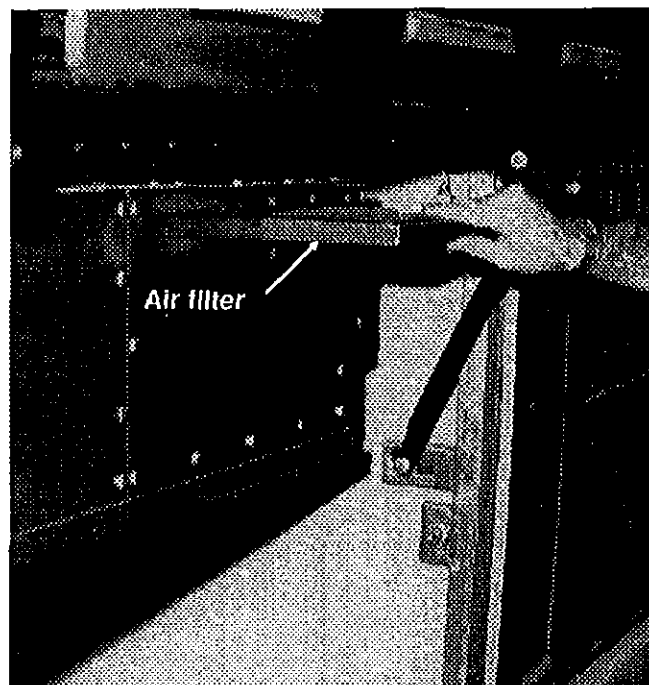

FIG. 10

OPFIG45.IMG

## Main HVAC unit removal

1. Drain the heating system as explained under "Draining the heating system".
2. Pump down the refrigeration system as explained under "Pumping down".
3. Set the 24 volt main disconnect switch to the "Off" position.
4. Disconnect the feed wire (+24 volts) on side of unit near the circuit breaker.
5. Disconnect the ground wire on side of unit near the other circuit breaker.
6. Disconnect the two sensor connectors.
7. Loosen clamp on each drain hose, then remove hoses from the unit.
8. Loosen the two clamps retaining the flexible air duct, then remove duct. Refer to figure 11.

**NOTE:** Perform steps 9 and 10 on side where the unit will be removed.

9. Remove the twelve (12) screws retaining the molding on unit, then the molding.
10. Remove the two (2) nuts securing the retainer plate, then the plate.

**NOTE:** The retainer plate is located at rear of duct and is accessible only when duct has been removed.

11. Repeat step 8 on other side of HVAC unit.
12. Disconnect and remove the two refrigerant lines connecting the existing lines to those of the HVAC unit. Cap open ends of the lines and open fittings to prevent further contamination of the system.

**WARNING:** Always wear goggles when handling refrigerant lines to prevent personal injury. Crack the lines and allow refrigerant to escape from the system before completely disconnecting the lines.

13. The HVAC unit is provided with glides. As unit can slide out of its compartment from either side of vehicle, push on one of its extremities. If unit does not slide easily, remove the angle iron screwed to the compartment ceiling and seated against the unit.

**WARNING:** Use an adequate supporting device (preferably a forklift truck) to support the unit at the other extremity during removal.

## Main HVAC unit installation

Reverse removal procedure. Fill the heating system as described under "Filling heating system" and add refrigerant as described under "Adding refrigerant".

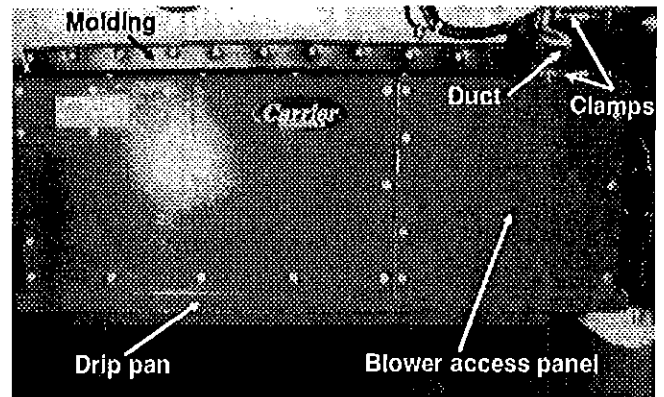

FIG. 11

MAS-1611.IMG

## BLOWER MOTOR

### Removal

1. Set the 24 volt main disconnect switch to the "Off" position.
2. Unfasten the six (6) latches securing the drip pan under the HVAC unit, then remove pan.
3. Remove the nine (9) bolts retaining the blower access panel (fig. 11).
4. Remove the set screw securing the blower to the motor shaft, then separate blower from shaft.
5. From under the HVAC unit, note position of the two (2) wires on the motor terminal board, then disconnect wires.
6. Loosen and remove the four (4) motor bracket retaining bolts and washers, while supporting the motor to prevent it from falling. Note quantity and position of shims under motor bracket, then remove motor.

**NOTE:** The left and right motors inside the HVAC unit are identical; however, the direction of rotation and their electric connections are different; the blowers are different and are not interchangeable; thus, note position of each blower before removal in order to replace them in their appropriate location.



**Disassembly** *S. A. 10/10*

**Preliminary disassembly** *S. A. 10/10*

1. Remove the brushes.
2. Unscrew the flange retaining screws on the shaft end side (opposite to the commutator end frame), and separate flange from frame (see fig. 12).
3. Remove flange and rotor assembly by pushing bearing shaft toward the commutator end frame.
4. Separate flange from rotor.

**Disassembly**

1. Perform preliminary disassembly.
2. Note carefully the position of the brush holder ring and the connections on the flange support.
3. Unscrew and remove the flange on the commutator end frame.
4. Remove the brush holder ring.
5. Finally, separate the following parts: brush holders, brush boxes, terminal board, bearings, etc...

**Maintenance** *S. A. 10/10*

**Checking operation of brush in holder** *S. A. 10/10*

Lift brush slightly 1/8" (3 mm) and release it; brush must produce a dry noise.

**Checking brush wear**

Replace the brushes if less than one third of the <sup>INITIAL</sup> ~~usable~~ brush length is left (17/64" (7 mm)). Clean brushes with a clean cloth impregnated with gasoline or alcohol.

**WARNING:** Cleaning products are flammable and may explode under certain conditions. Always handle in a well ventilated area.

**Checking commutator**

The surface must be polished. A brown-black colored surface is normal and indicates a good switching. Ensure there is no evidence of arcing or metal chips.

**Lubrication**

The motor is provided with two (2) sealed bearings which require no maintenance.

**Reassembly**

Reverse disassembly procedure.

**Installation**

Reverse removal procedure. Apply grease on the motor shaft to ease blower installation. If wire connections are reversed on the motor terminal board, the direction of motor rotation will be changed, thus rendering the motor inefficient.

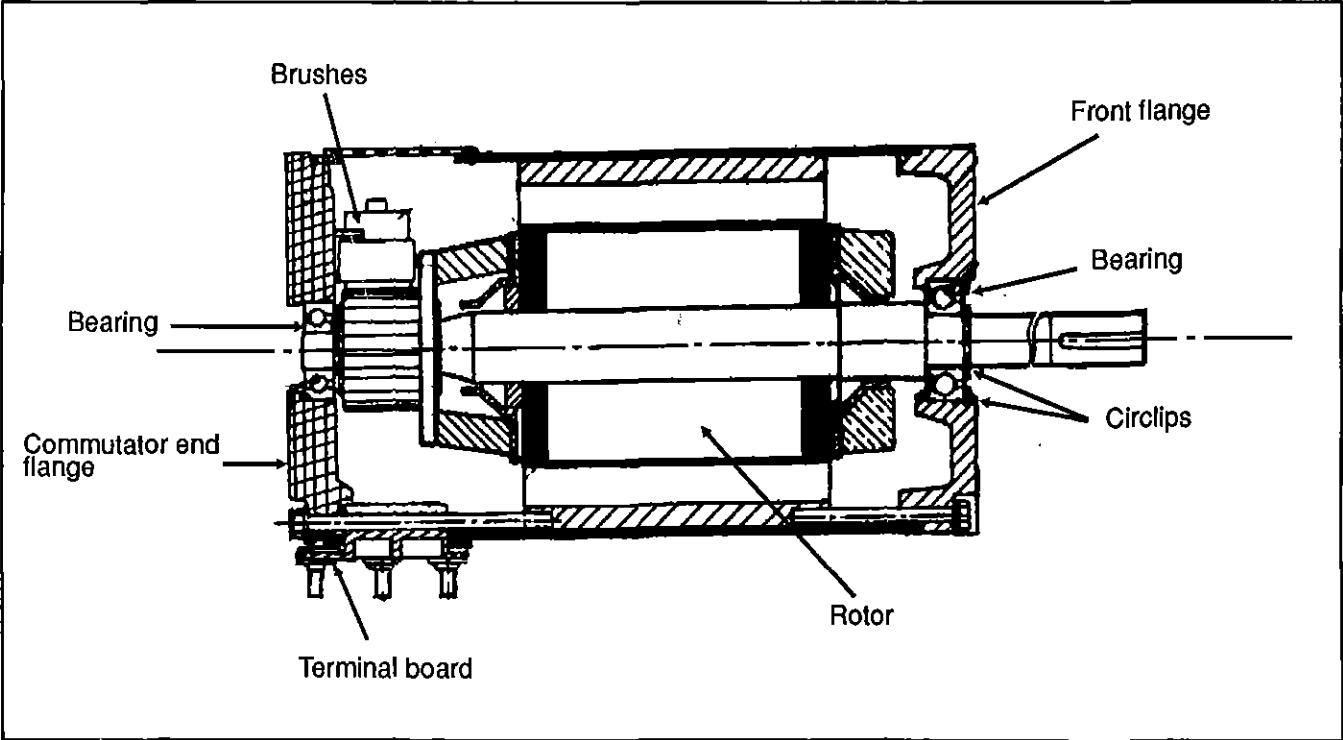

FIG. 12

MA5-1612.IMG

## AIR CONDITIONING SYSTEM

### Description

The schematic of figure 13 shows the A/C system and its components. The system is equipped with a 6 cylinder, 05G Carrier compressor and R-22 Freon, thus providing a 12 ton A/C capacity. The receiver is mounted underneath the condenser, with a sight glass pointing out when the condenser door is opened. A small access panel allows viewing of the filter dryer sight glass for an easy day-to-day refrigerant charge verification.

The refrigerant at the outlet of condenser flows in the receiver tank, then leaves again the receiver in order to circulate in subcooling rows of the condenser, and finally is routed to the evaporators. This recirculation ensures a liquid line to the evaporator.

The magnetic clutch will be engaged approximately 50 seconds after an A/C request, due to a time delay module. This time delay avoids continuous engaging and disengaging (cycling) of clutch.

### Refrigerant

The refrigerants used are commonly known by their trade name: Freon-22, Isotron-22, or Genetron-22. Regardless of the brand, refrigerant-22 must be used in this system. The chemical name for refrigerant-22 is monochlorodifluoromethane.

### Refrigerant characteristics

Refrigerant exists as a gas at atmospheric pressure and must be held under pressure to remain liquid. At ordinary temperatures, it will exist as a liquid under a pressure of about 75 psi (516,75 kPa). Refrigerant is colorless in both its liquid and gaseous states, and it has very little odor; however, a distinct odor may be detected in large concentrations.

Refrigerant is nonpoisonous, nonflammable, nonexplosive, as well as being noncorrosive to any of the ordinary metals. Goggles should be worn whenever there is the slightest possibility of refrigerant coming in contact with the face or eyes, because refrigerant evaporates and cools so rapidly that it will cause an injury similar to frostbite.

**WARNING: Refrigerant in itself is nonflammable, but if it contacts an open flame, it will decompose in phosgene gas which is toxic.**

### Procurement

Refrigerant is shipped and stored in metal cylinders. It is serviced in 22 and 100 pound (10 and 45 kg) cylinders. Approximately 44 pounds (20 kg) are used in the system.

It will be impossible to draw all the refrigerant out of the cylinder; however, the use of warm water when charging the system will ensure the extraction of a maximum amount of refrigerant from the cylinder.

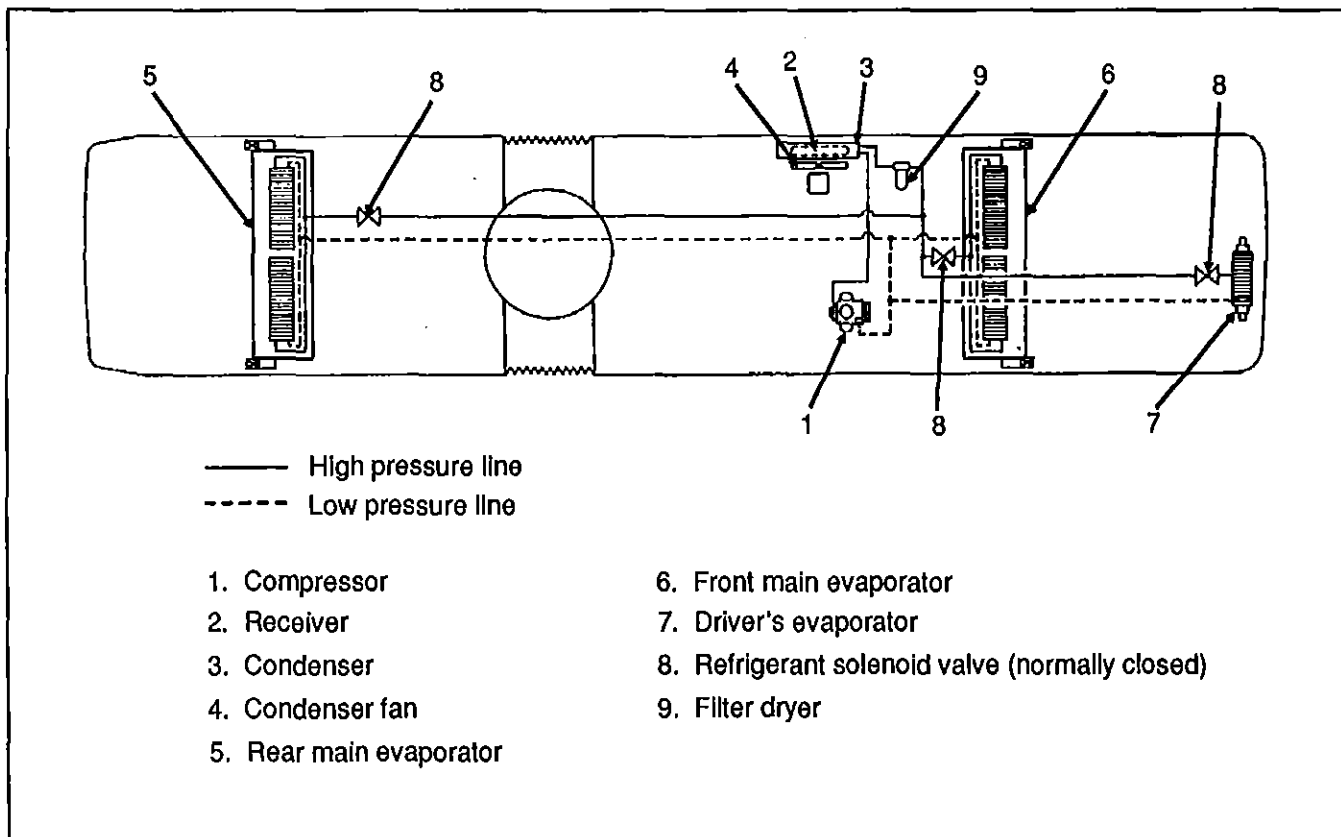

FIG. 13 - Refrigerant circuit

MA5-1613.MG

### Precautions in handling refrigerant

1. Do not leave a cylinder of refrigerant uncapped.
2. Do not subject the cylinder to high temperatures.
3. Do not weld or steam clean on or near the system.
4. Do not fill a cylinder completely.
5. Do not discharge vapor into an area where a flame is exposed.
6. Do not expose the eyes to liquid refrigerant.

All refrigerant cylinders are shipped with a heavy metal screw cap. The purpose of the cap is to protect the valve and safety plug from damage. It is a good practice to replace the cap after each use of the cylinder for the same reason. If the cylinder is exposed to the sun radiant heat, the resultant increase in pressure may cause the safety plug to release or the cylinder to burst.

For the same reason, the refrigerant cylinder should never be subjected to excessive temperature when charging a system. The refrigerant cylinder should be heated for charging purposes by placing it in 125 °F (52 °C) water. Never heat above 125 °F (52 °C) or use a blowtorch, radiator, or stove to heat the cylinder.

Welding or steam cleaning on or near any refrigerant line or components of the A/C system could build up dangerous and damaging pressures in the system.

If a small cylinder is ever filled from a large one, never fill the cylinder completely. Space should always be allowed above the liquid for expansion. Weighing cylinders before and during the transfer will determine the fullness of the cylinders.

**WARNING: One of the most important precautions when handling refrigerant consist in protecting the eyes. Any liquid refrigerant which may accidentally escape is approximately -40 °F (-40 °C). If refrigerant comes in contact with the eyes, serious injury could result. Always wear goggles to protect the eyes when opening refrigerant connections.**

Discharging large quantities of refrigerant into a ventilated room can usually be done safely as the vapor would produce no ill effects. However, this should not be done if the area contains a flame-producing device such as a gas heater. While refrigerant alone is nonpoisonous, heavy concentrations of it in contact with a live flame will produce a poisonous gas. The same gas will attack all metal surfaces.

### Treatment in case of injury

If liquid refrigerant comes in contact with the skin, treat the injury as if the skin was frost-bitten or frozen.

If liquid refrigerant comes in contact with the eyes, consult an eye specialist or doctor immediately. Give the following first aid treatment:

1. Do not rub the eyes. Splash eyes with cold water to gradually bring the temperature above the freezing point.
2. Apply drops of sterile mineral oil (obtainable at any drugstore) in the eyes to reduce the possibility of infection. The mineral oil will also help in absorbing the refrigerant.

### Precautions in handling refrigerant lines

1. All metal tubing lines should be free of kinks, because of the restriction that kinks will offer to the flow of refrigerant. The refrigeration capacity of the entire system can be greatly reduced by a single kink.

2. The flexible hose lines should never be allowed to come within a distance of 2 1/2" (6,3 cm) of the exhaust manifold.

3. Use only sealed lines from parts stock.

4. When disconnecting any fitting in the refrigeration system, the system must first be discharged of all refrigerant. However, proceed very cautiously, regardless of gauge readings. Open very slowly, keeping face and hands away so that no injury can occur, if there happens to be liquid refrigerant in the line. If pressure is noticed when fitting is loosened, allow it to bleed off very slowly.

**WARNING: Always wear safety goggles when opening refrigerant lines.**

5. In the event any line is opened to atmosphere, it should be immediately capped to prevent entrance of moisture and dirt.

6. The use of the proper wrenches when making connections on O-ring fittings, is important. The use of improper wrenches may damage the connection. The opposing fitting should always be backed up with a wrench to prevent distortion of connection lines or components. When connecting the flexible hose connections, it is important that the swaged fitting and the flare nut, as well as the coupling to which it is attached, be held at the same time using three different wrenches to prevent turning the fitting and damaging the ground seat.

7. The O-rings and seats must be in perfect condition. The slightest burr or piece of dirt may cause a leak.

8. O-rings should be coated with refrigeration oil (525 viscosity) and installed on the line before the line is inserted into the fitting to prevent damaging the O-ring. If leaks are encountered at the couplings or connectors, no attempt should be made to correct the leaks by tightening the connections beyond the recommended torque. The O-rings are designed to seal at the specified torque and overtightening the connection does not result in a satisfactory and permanently sealed connection. The connection must be disassembled and the cause of the leak (damaged O-ring, defective lines, etc.) corrected. Use new O-ring.

## Pumping down

### Description

This procedure is intended to reduce refrigerant (Freon 22) loss by isolating it in the compressor and the receiver tank, as well as in their connecting line, in order to carry out repairs on other sections of the air conditioning system (lines and components).

**WARNING:** When air conditioning system must be opened, refer to previous heading "*Precautions in handling refrigerant*" to prevent any injury.

### Procedure

1. Close the outlet valve on the receiver tank by turning it clockwise until the valve is frontseated, backseat the suction valve on the compressor, install an appropriate pressure gauge set, then turn the valve forward 1/4 turn to enable a visual check of the suction pressure.

2. Disconnect the connector at the "*Low pressure switch*", then install a jumper wire.

**NOTE:** This jumper wire will allow the clutch to remain engaged after pressure drops below 35 psi (241 kPa).

3. Open the third R.H. side baggage compartment door, locate "*Engine junction box*", remove the screws retaining the panel on side of box, then remove the panel. Using the decal at back of panel to ease identification of diodes, locate diodes D-6 and D-9, then connect a jumper wire at the bottom part of each diode (i.e. on the end opposite to the grey stripe). In fact, wire 2B will be connected to wire 31A (see fig. 14).

**NOTE:** The jumper wire will restrict compressor operation to two (2) cylinders.

4. Start the engine, turn "*On*" the "*Passenger A/C-heating*", then adjust "*A/C-heating*" controls to *maximum A/C position*.

5. Run the compressor until pressure reaches 1-2 psi (7-14 kPa).

**NOTE:** During this operation, care must be taken not to fill the receiver tank over the sight glass. It may be necessary to vent the tank. Always allow refrigerant piping and units to warm up to the ambient air temperature before opening system or sweating will take place inside the lines.

6. Stop engine, and close compressor outlet valve by turning it clockwise until properly seated.

7. Close compressor suction valve by turning it clockwise until it is properly seated.

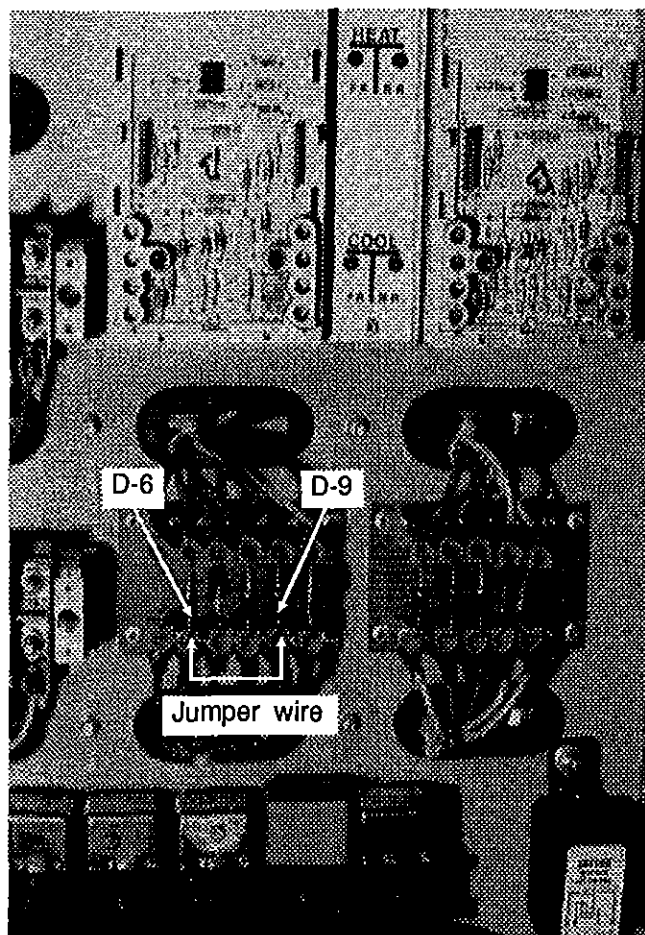

FIG. 14

MAS-1614.IMG

## Adding refrigerant

Use the suction service valve on the compressor to add refrigerant to the system. Backseat the valve and connect a charging line from the refrigerant cylinder to the valve loosely. Tighten connection at level of refrigerant cylinder and open tank end slightly to purge air from the charging line. Tighten the charging line at the compressor. Screw in the stem of suction valve approximately two turns. Start the engine and run at fast idle. Add refrigerant until the system inner pressure value matches the data of Table "*High pressure vs exterior temperature*" hereafter. Always charge the system with the cylinder upright and the valve on top to avoid drawing liquid out of the cylinder.

**NOTE:** Bubbles in the filter dryer sight glass do not always indicate a lack of refrigerant. It may be the starting of an evaporation as the filter dryer is located in a relatively warm compartment. Consequently, refer to the table "*High pressure vs exterior temperature*" before adding refrigerant to avoid overcharging system. When charging an empty system, weigh the amount of refrigerant put into the system. This will eliminate any possibility of overfilling. A full charge is exactly 44 pounds (20 kg).

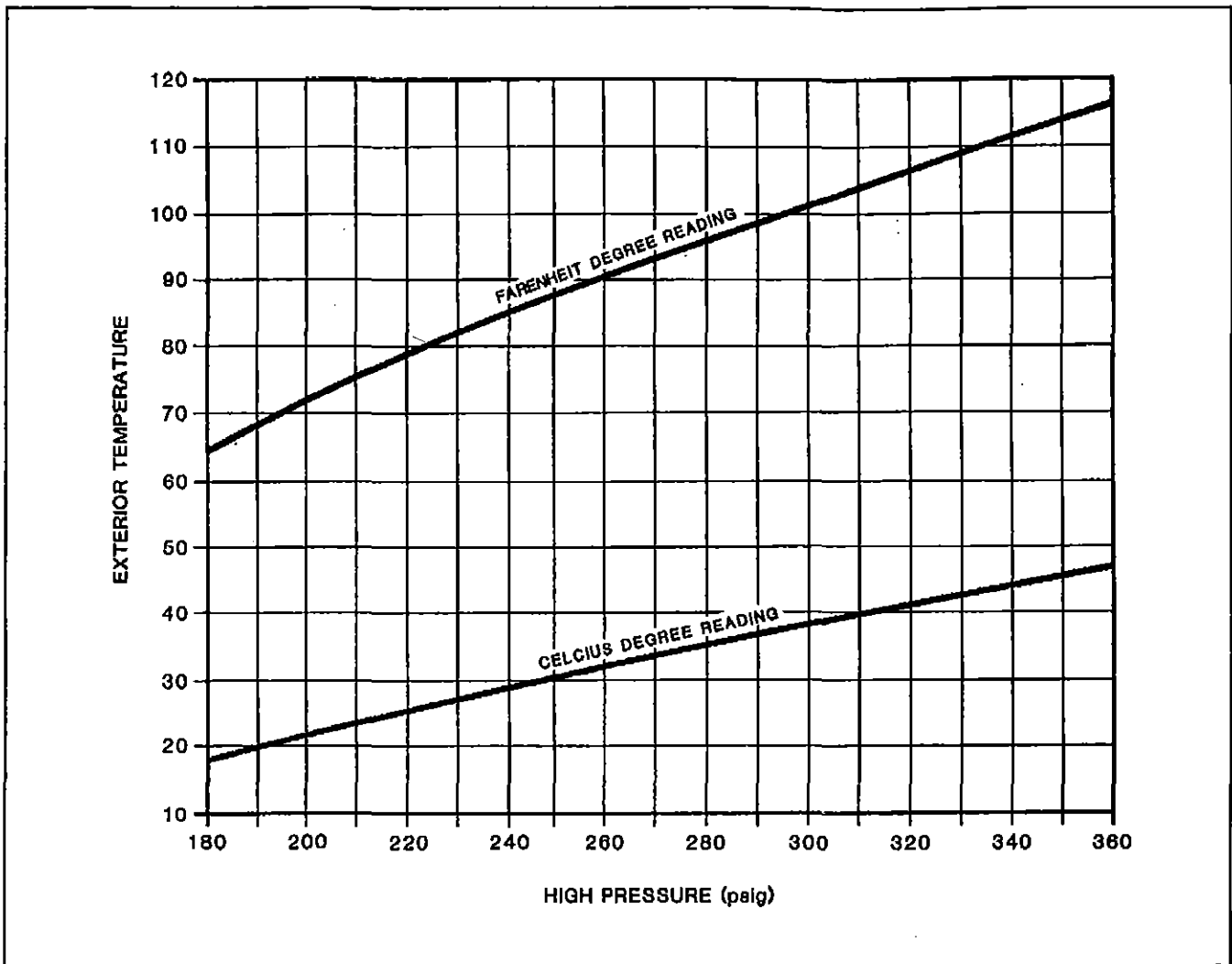

HIGH PRESSURE VS EXTERIOR TEMPERATURE

MA51614AJMG

## A/C SYSTEM COMPONENTS

### Compressor

#### Belt replacement

See "A/C compressor belt replacement" in section 3.

#### Troubleshooting guide

A preliminary check may be made by simply feeling the cylinder heads with the unit in operation at ambient temperatures of 35 °F (2 °C) and below. The cylinder heads are internally divided into suction and discharge halves; the lower half of the cylinder head is the suction side, and it should be relatively cool to the touch, as opposed to the hot upper discharge side. If a valve plate or head gasket is blown, or a compressor unloader is stuck open, partially compressed refrigerant vapor will be circulated between the suction and discharge sides of the head. The affected cylinder head will then have a relatively even temperature across its surface and be

neither as hot as the normal discharge temperature, nor as cool as the normal suction temperature.

Broken suction valves are probably the most difficult item to determine without opening the compressor. Depending on the condition of the cylinder walls and piston rings, a compressor in good condition should be able to pull a vacuum of 20" Hg with the suction service valve frontseated. Failure to reach this value would require disassembly of the compressor to determine actual component conditions.

#### Blown head gaskets:

Symptom: - Loss of unit capacity at low temperature

- Even cylinder head temperature

Cause: - Improperly torqued cylinder head bolts

- Improperly positioned gasket at assembly

- Warped cylinder head

- Severe liquid refrigerant floodback

**Blown valve plate gaskets:**

- Symptom: - Loss of unit capacity at medium and low temperatures
- Very hot cylinder head surface
  - Higher than normal suction pressure

- Cause: - Improperly torqued cylinder head bolts
- Severe liquid refrigerant floodback
  - Oil slugging caused by an overcharge of oil or flooded starts
  - Discharge valves not seating properly (liquid drainback during shutdown)

**Broken suction valves:**

- Symptom: - Loss of unit capacity at all temperatures
- Compressor unable to pull extremely low vacuum with suction service valve frontseated

- Cause: - Repeated liquid refrigerant floodback
- Flooded starts
  - Overcharge of oil
  - Discharge valves not seating properly (liquid drainback during shutdown)
  - Expansion valve not controlling properly

**Unloader valve stuck open:**

- Symptom: - Loss of unit capacity at all temperatures
- Higher than normal suction pressure
  - Even cylinder head temperature

- Cause: - Unloader body stem bent
- Foreign material binding unloader piston or plunger

**Cylinder wall wear - broken piston rings:**

- Symptom: - No apparent loss of capacity except at extreme low temperature applications
- 10 °F (-23 °C) and below
  - Low crankcase oil level during operation, oil returns to crankcase at unit shutdown

**Cause of erratic oil levels:**

- Broken piston rings
- Cylinder bore out of round
- Hole in piston
- Oil equalizer passage in crankshaft blocked
- Oil return check valve stuck closed

**Maintenance**

For the maintenance of A/C compressor, see the "Carrier Compressor Operation and Service Manual" included at the end of this section.

**Magnetic clutch**

Refer to Carrier service information entitled "Housing-mounted electric clutch" at the end of this section for the description and maintenance of the magnetic clutch.

**Time delay module**

A time delay module located inside the "Engine junction box" and mounted under the six (6) main circuit breakers, is connected in series with the feeder circuit of the compressor magnetic clutch. This module allows a 50 second delay following a compressor clutch request and its actual application, to avoid continuous engaging and disengaging (cycling) of clutch.

**Condenser**

The condenser coil is hinge mounted on the L.H. side of the engine compartment door. Since the condenser's purpose is to dissipate heat from the hot refrigerant, it is important to keep the cooling coils and fins clean. A clogged coil will cause high discharge pressure and insufficient cooling.

Check the external surface of the coil at regular intervals (5000 miles (8 000 km) or more often according to operating conditions) for dirt or any other foreign matter. Flush the condenser coil from inside out, using a water jet or water mixed with air pressure. Direct the pressure straight through the coil to prevent bending of fins.

**CAUTION:** Do not use high pressure to prevent bending of fins.

## Receiver tank

The receiver tank is located under the condenser and is fixed by four retaining bolts. The function of the receiver tank is to store the liquid refrigerant. The receiver tank is provided with an outlet valve on its outlet side which permits isolation from the rest of the system. In case of extreme pressure rise in the liquid receiver tank, a pressure relief valve (see fig.15) will break at 450 psi (3 103 kPa) and relieve the receiver tank pressure.

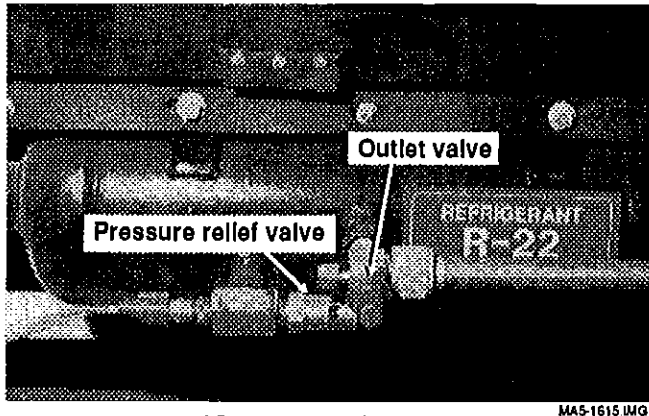

FIG. 15 - Receiver tank

## Filter dryer

### Description

A filter dryer located in the engine compartment, is installed on the circuit between the condenser and solenoid valves. It is used to absorb moisture from the refrigerant. The filter should be replaced if the system has been opened to prolonged exposure as shown by the moisture indicator sight glass.

### Replacement

The filter is of the disposable type. When replacement is required, remove and discard the complete unit and replace with a new unit of the same type according to this procedure:

1. Isolate the refrigerant in the receiver tank by following the "Pumping down" procedure stated previously.
2. Change the filter dryer as a unit.
3. Admit a small quantity of refrigerant (R-22) to the low side of the system. Check for leaks. Return the system to normal operation.

**CAUTION:** Do not use carbon tetrachloride or similar solvent to clean parts. Do not use steam guns. Use mineral spirits or naphtha. All parts should be thoroughly cleaned. Use a stiff brush to wash dirt from grooves, holes, etc.

**WARNING:** Cleaning products are flammable and may explode under certain conditions. Always handle in a well ventilated area.

## Moisture indicator

The moisture sensitive element consists of a color changing ring which is reversible from pink to blue and vice versa as the moisture content in the refrigerant changes. Pink indicates a wet refrigerant, light violet (caution) and blue indicates a dry refrigerant.

Since temperature changes affect the solubility, the color change will also vary with the refrigerant temperature. The following table shows the color change for R-22 at various moisture levels and liquid line refrigerant temperatures.

REFRIGERANT R-22			
INDICATOR COLOR			
TEMPERATURE	BLUE	LIGHT VIOLET	PINK
	(ppm)	(ppm)	(ppm)
75 °F (24 °C)	Below 30	30-120	Above 120
100 °F (38 °C)	Below 45	45-180	Above 180
125 °F (52 °C)	Below 60	60-240	Above 240

ppm = parts per million (moisture content)

A moisture level of 60 ppm for refrigerant 22, indicated in the blue color range of the above table, is generally considered dry and safe. A color indication of light blue to light violet indicates the caution range of moisture level. For positive protection, the drying of the system should be continued until the color of the element turns deep blue.

Moisture is one of the main causes of chemical instability or contamination in air conditioning systems. If moisture is present, it can corrode the valves, condenser and evaporator coils, compressor and other components causing a malfunction and eventual failure of the system. Uncontrolled moisture in the system can result in very expensive multiple component replacements if not corrected at an early stage. The moisture indicator permits an early detection of moisture in the system, and when corrected by a desiccant charge, system contamination is greatly minimized.

## Refrigerant solenoid valve

### Description

Three (3) identical normally-closed solenoid valves regulate the flow of refrigerant (see fig. 16). The driver's A/C unit valve is located on the ceiling of the compartment at rear of front bumper. The two (2) other ones are located near the main HVAC units (HVAC), and are accessible through the baggage compartments.

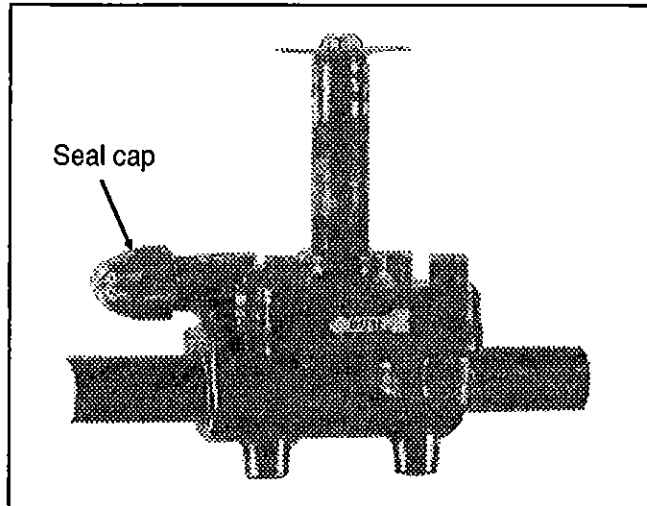

FIG. 16 - Refrigerant solenoid valve (without coil)

### Manual bypass

This type of solenoid valve is equipped with a manual operating stem. The 3/16" square stem located on the bonnet is exposed when seal cap is removed. To manually open valve, turn stem 1/2 turn counterclockwise. To manually close the valve, turn stem clockwise until tight against seat. Manual stem must be in closed position for automatic electric operation.

### Coil replacement

1. Disconnect connector from the coil connector.
2. Take out the retaining screw at the top of the coil housing. The entire coil assembly can then be lifted off the enclosing tube.
3. Place the new coil and yoke assembly on the enclosing tube; lay data identification plate in place.
4. Insert the coil retaining screw, rotate housing to proper position and tighten screw securely.
5. Connect connector from coil connector.

### Valve disassembly

1. Remove the coil as stated previously.
2. Pump down the system as stated earlier in this section.

3. Remove the four (4) socket head screws which hold the body and bonnet together (see fig.17).
4. Carefully lift off the bonnet assembly (upper part of the valve) so that plunger will not fall out. The diaphragm can now be lifted out.

**CAUTION:** Be careful not to damage the machined faces while the valve is apart.

**NOTE:** The above procedure must be followed before brazing solder type bodies into the line.

### Valve reassembly

1. Place the diaphragm in the body with the pilot port extension up.
2. Hold the plunger with the synthetic seat against the pilot port.
3. Make sure the bonnet O-rings are in place, then lower the bonnet assembly over the plunger, making sure that the locating sleeve in the bonnet enters the mating hole in the body.
4. Insert the four (4) socket head screws and tighten evenly.
5. Replace the coil as stated previously.
6. Admit a small quantity of refrigerant (R-22) to the low side of the system. Check for leaks. Return the system to normal operation.

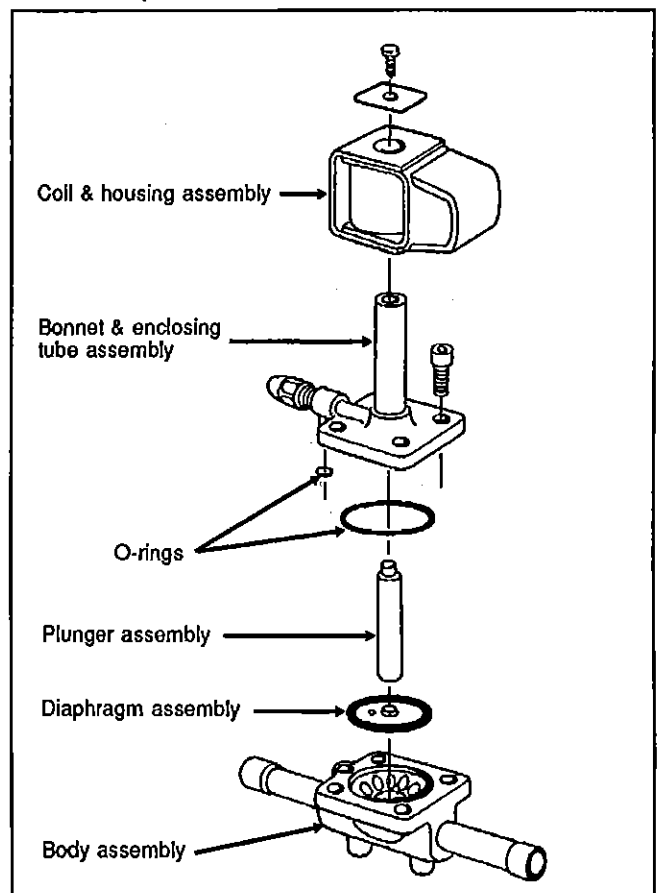

FIG. 17 - Refrigerant solenoid valve disassembly



## HUMIDISTAT

### Description

This control, which is frequently used in houses, activates a humidifier in cases where the humidity rate of ambient air in house is lower than the rate selected manually on the humidistat. The same control is used on this vehicle, with the exception that inside ambient air of vehicle must be dried when the humidity rate is too high. To do so, the signal transmitted by the humidistat is reversed by the use of normally-closed relays.

Air is dried by operating A/C systems. Thus, the humidistat is a control which enables the bypassing of the A/C system controls. The normally-closed relay R-32 bypasses the front main A/C unit control, and the R-30, the rear main A/C unit control. Both relays are located in the "engine" junction box. This means that when the heating system is operating, the A/C system can also operate simultaneously. Only one humidistat regulates the front and rear main A/C systems. The control is located on the ceiling of the first baggage compartment in front section, near the A/C-heating unit. The humidistat sensor is located in the plenum to the side of control.

### Setting

Set humidistat control to provide a humidity rate of 30%.

### Checkout

1. Start engine and switch on the "Passenger A/C-heating" switch.
2. Turn clockwise the two "A/C-heating temperature" controls in order that the two (2) main units operate in the heating mode. The two (2) red LEDs located under the R.H. side console should illuminate to indicate that the two (2) main heating units are operating.
3. Turn the control knob of the humidistat counterclockwise to the "Off" position. At this moment, the two (2) main A/C units should start operating. The two (2) green LEDs located under the R.H. side console should also illuminate to indicate that the two (2) main A/C units are operating.
4. Turn the control knob of the humidistat clockwise to its maximum position; the two (2) main A/C units should shut off immediately. The two (2) green LEDs should turn off.
5. Reset humidistat control in order to provide a humidity rate of 30 %.

## Maintenance

Do not apply oil to any part of the humidistat. To insure trouble-free performance, the nylon element should be inspected periodically. Dirt and grease will not damage the element, but may reduce its sensitivity. If necessary, remove accumulated dust and dirt with a soft bristled brush.

## CONDENSER FAN HYDRAULIC SYSTEM

### Description

The 26" diameter condenser fan is hydraulically driven (see fig. 18), and as the compressor, its speed will vary according to the engine rpm, since the pump is belt driven from the engine. The fan motor speed will vary almost accordingly to the engine speed, at about 50 rpm less.

The condenser fan motor normally functions along with the compressor, except in the two following conditions:

1. High pressure at compressor.
  - Fan is still operating.
  - Compressor magnetic clutch is disengaged.
2. Pressure in receiver tank has not build up to 150 psi (1 035 kPa).
  - Fan is not operating.
  - Compressor magnetic clutch is engaged.

The on/off control of the fan is provided by a normally-opened (NO) solenoid control relief valve. When solenoid is energized, the relief valve vent is blocked and the valve will work as a normal safety relief valve, and will only dump to the tank at an approximate pressure of 1250 psi (8 618 kPa).

When the solenoid is deenergized, the relief valve is vented, and a low pressure (about 15 psi (103 kPa)) will open the valve and divert the flow to the tank.

A heat exchanger is series mounted after the fan motor. Consequently, oil is cooled only when required, i.e. when the fan motor is operating. Moreover, a check valve which opening pressure is set at 5 psi (34 kPa), is located in a line paralleled with the heat exchanger line, in order that oil bypasses the heat exchanger in the event of clogging, or that oil is too thick.

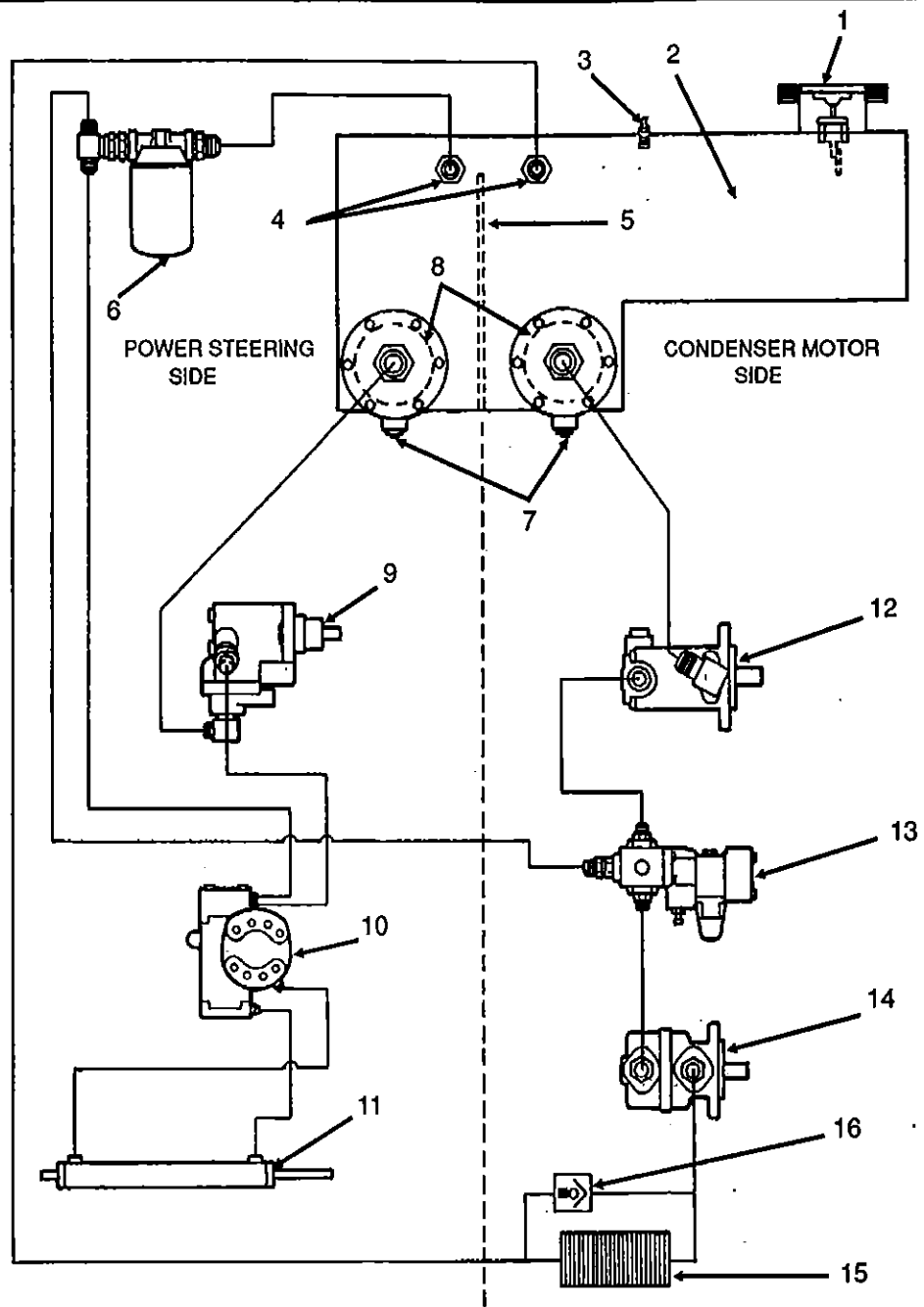

- |                                      |                                   |
|--------------------------------------|-----------------------------------|
| 1. Hydraulic oil tank cap & dipstick | 9. Power steering pump            |
| 2. Hydraulic oil tank                | 10. Steering gearbox              |
| 3. Reserve tank vent port            | 11. Steering cylinder             |
| 4. Return lines                      | 12. Hydraulic pump                |
| 5. Tank separator (inside tank)      | 13. Solenoid control relief valve |
| 6. Return line filter (10 microns)   | 14. Condenser fan motor           |
| 7. Drain plugs                       | 15. Oil cooler                    |
| 8. Strainers (25 microns)            | 16. Check valve                   |

FIG. 18 - Hydraulic circuit schematic

MA5-1618/JMG

## Hydraulic components

### Condenser fan motor

For the description, maintenance and troubleshooting of this motor, refer to the *"Vane Motors Overhaul Manual"* at the end of this section.

### Condenser fan motor rotation speed

To determine if the motor speed, and simultaneously the fan speed are appropriate, two procedures can be used according to the available instruments:

1. Using a strobe lamp, note fan speed, then the engine rpm; the fan speed must be 50 rpm less than the engine speed.

OR

2. Install an oil pressure gauge on the inlet of the condenser fan hydraulic motor. Run engine at full rpm (2100) with A/C system operating, then note gauge reading. A pressure range of 1000 to 1250 psi (6 895 - 8 618 kPa) indicates that fan speed is satisfactory.

## Hydraulic pump

### Description

The hydraulic pump of the condenser fan is mounted on engine side near the block heater, and is driven by two (2) belts connected to the engine camshaft pulley.

### Belt replacement

1. Set the 24 volt disconnect switch to the "Off" position.
2. Loosen the hydraulic pump bracket mounting and adjusting bolts (see fig. 19).
3. Push the hydraulic pump towards the engine.
4. Slip the old belts off and the new ones on.
5. Pry the hydraulic pump away from the engine to tighten the belts, then tighten the bolts. To check tension, press the belts midway between pulleys; the deflection must be approximately 1/2 - 3/4 " (13-19 mm).

**NOTE:** Both belts must always be replaced simultaneously to ensure an equal distribution of load on each of them.

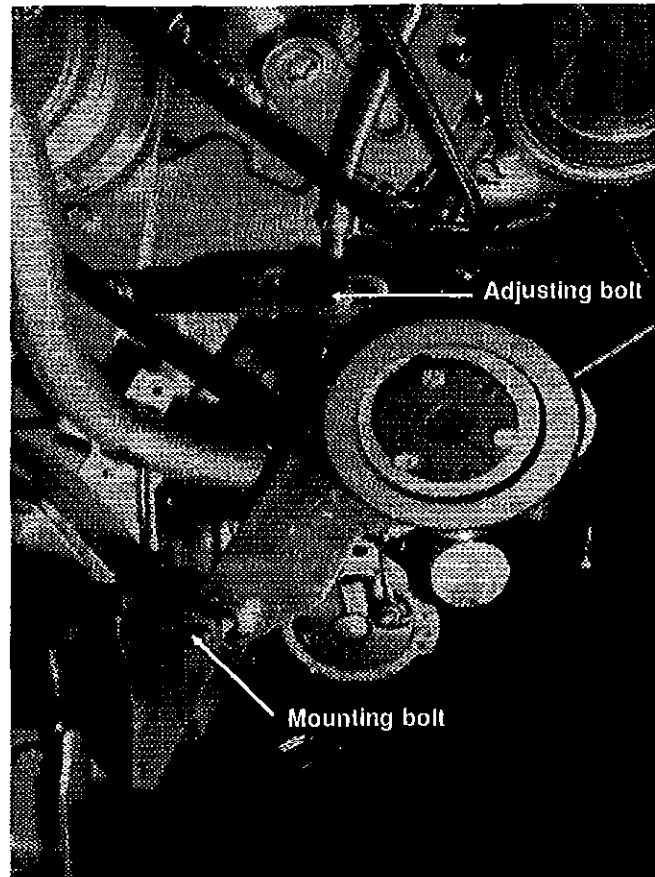

MAS-1619JMG

FIG. 19 - Hydraulic pump

### Maintenance

For the maintenance and troubleshooting of the hydraulic pump, refer to the *"Vane Pumps Overhaul Manual"* at the end of this section.

## Solenoid control relief valve

### Description

The solenoid control relief valve is mounted on the engine compartment floor (see fig. 20) near the preheater. This valve consists of several subassemblies such as balanced piston relief valve, directional control valve and solenoid. The hydraulic schematic of figure 21 indicates the interrelations between the valve and the different components of the condenser motor hydraulic system.

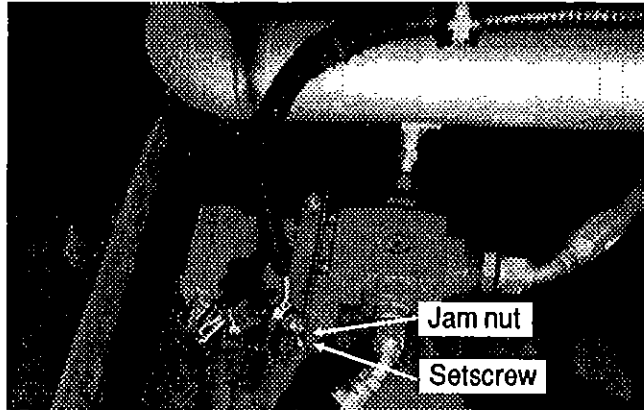

FIG. 20 - Solenoid control relief valve

### Maintenance

For the maintenance and troubleshooting of the solenoid control relief valve, refer to the two (2) enclosed overhaul

manuals at the end of this section: "Balanced Piston Relief Valve" and "Directional Control Valve".

### Adjustment

The maximum pressure in the condenser motor hydraulic system must be 1250 psi (8 618 kPa); proceed as follows to set relief valve:

1. Remove plug near the "Gauge" engraving on top of the relief valve, then install an appropriate pressure gauge.
2. Loosen jam nut, turn setscrew clockwise until seated, then unscrew it 1/2 of a turn.
3. Ensure transmission is in neutral range, apply parking brake, start engine and run at full rpm (2100); push down the "Passenger A/C-heating" rocker switch, then turn the two (2) "A/C-heating temperature" controls to their maximum cooling position.
4. During the condenser motor operation, note reading on pressure gauge.
5. If reading does not equal 1250 psi (8 618 kPa), complete adjustment by turning the setscrew clockwise to increase pressure, and counterclockwise to decrease pressure.
6. Lock the setscrew with the jam nut.

**NOTE:** If following this procedure, pressure is still not equal to 1250 psi (8 618 kPa), remove or add a spacer as required according to the spacer location in the exploded view of the "Balanced piston relief valve" given in the overhaul manual at the end of this section.

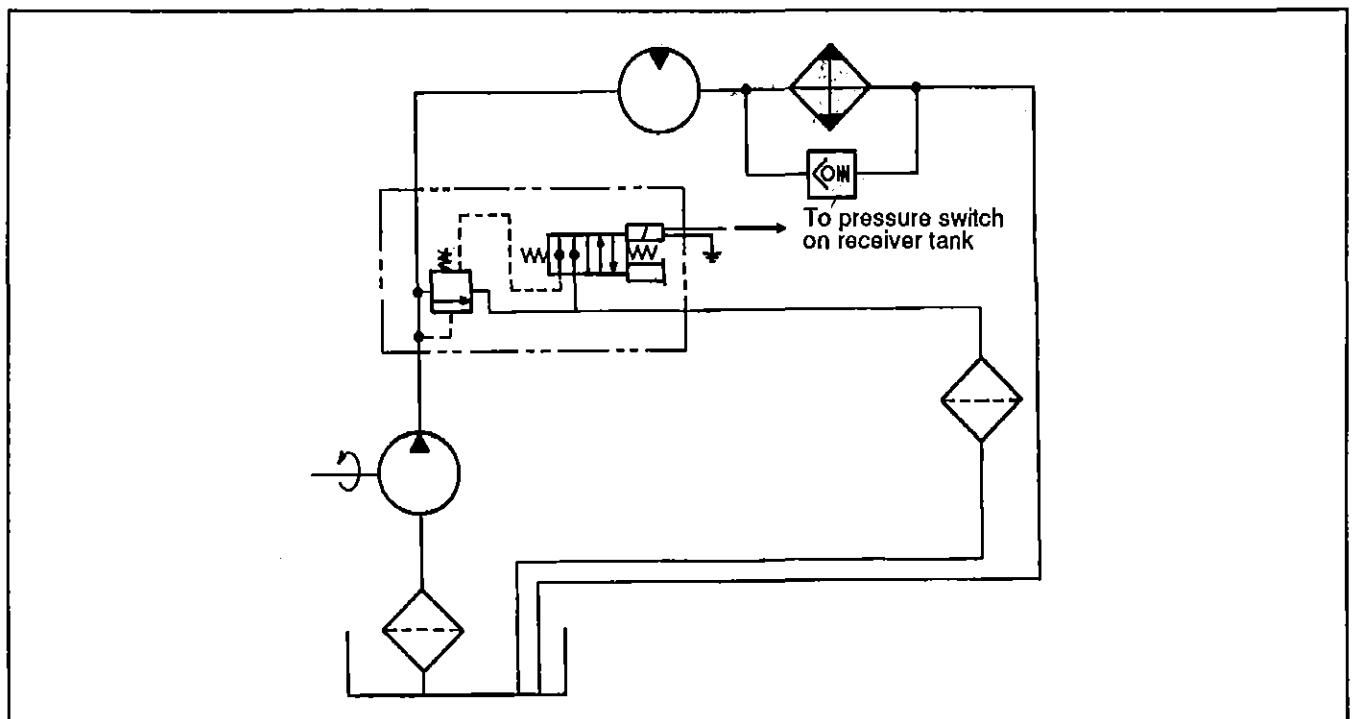

FIG. 21 - Hydraulic circuit of the condenser fan motor

MAS-1621 JMG

## Hydraulic oil filter

### Description

The spin-on type filter used in the power steering and condenser fan motor hydraulic circuits is mounted on the return line of these two components in the engine compartment. To gain access, open the third R.H. side baggage compartment door and raise the engine access panel; the filter is located on the left side near the rear wall.

### Replacement

Replace filter at 50,000 mile (80 000 km) intervals according to the following procedure:

1. Stop engine.
2. Unscrew the filter and discard it.
3. Clean the filter base surface.
4. Apply clean oil on gasket of new filter.
5. Tighten filter 7/8 to 1 turn after gasket contacts base.
6. Check for leaks.

## Hydraulic oil tank

### Description

The hydraulic oil tank is located into the L.H. side drive axle wheelhouse. This reservoir feeds oil to the hydraulic circuits of the power steering and the condenser motor (see fig. 18). This reservoir has been specially designed with the adjunction of an inside partition and the location of the oil returns. Thus, if an oil leak should occur on the hydraulic circuit of the condenser fan motor, this section of the reservoir would empty, while the other section of the tank would not be affected. The power steering hydraulic circuit would operate normally and safely. The opposite is not applicable if there is a leak in the power steering hydraulic system. The section of this tank will drain completely, and as soon as the solenoid control relief valve on the condenser motor hydraulic circuit is deactivated, the remaining oil in reservoir would drain gradually. The total capacity of tank is 8 U.S. gal (30,3 liters) including the hoses.

### Oil verification

1. Stop engine, and open L.H. side ski compartment.
2. Remove the twist dipstick located in the L.H. side corner and wipe with a clean rag (see fig. 22).
3. Insert dipstick in tank, then remove it again to check level.
4. Bring level to the "FULL" mark with SAE 5W30 engine oil for moderate weather areas and SAE 10W30 engine oil for the other areas.
5. Replace the twist dipstick and screw it.

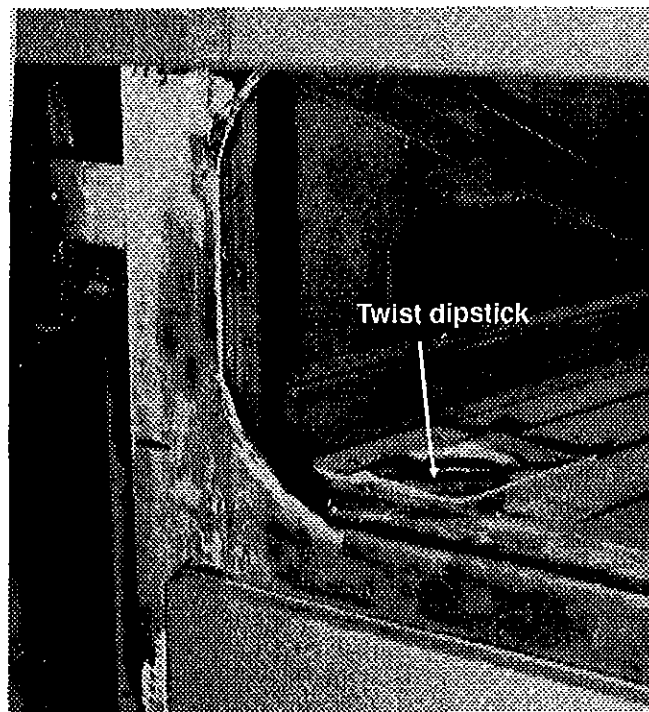

FIG. 22 - Hydraulic oil tank

OPFIG41.JPG

## HEATING SYSTEM

### Description

The schematic of figure 23 shows the heating system components and ducting.

In addition to the normal heating provided by the engine, a 103,000 BTU/hr preheating system has been installed in the engine compartment.

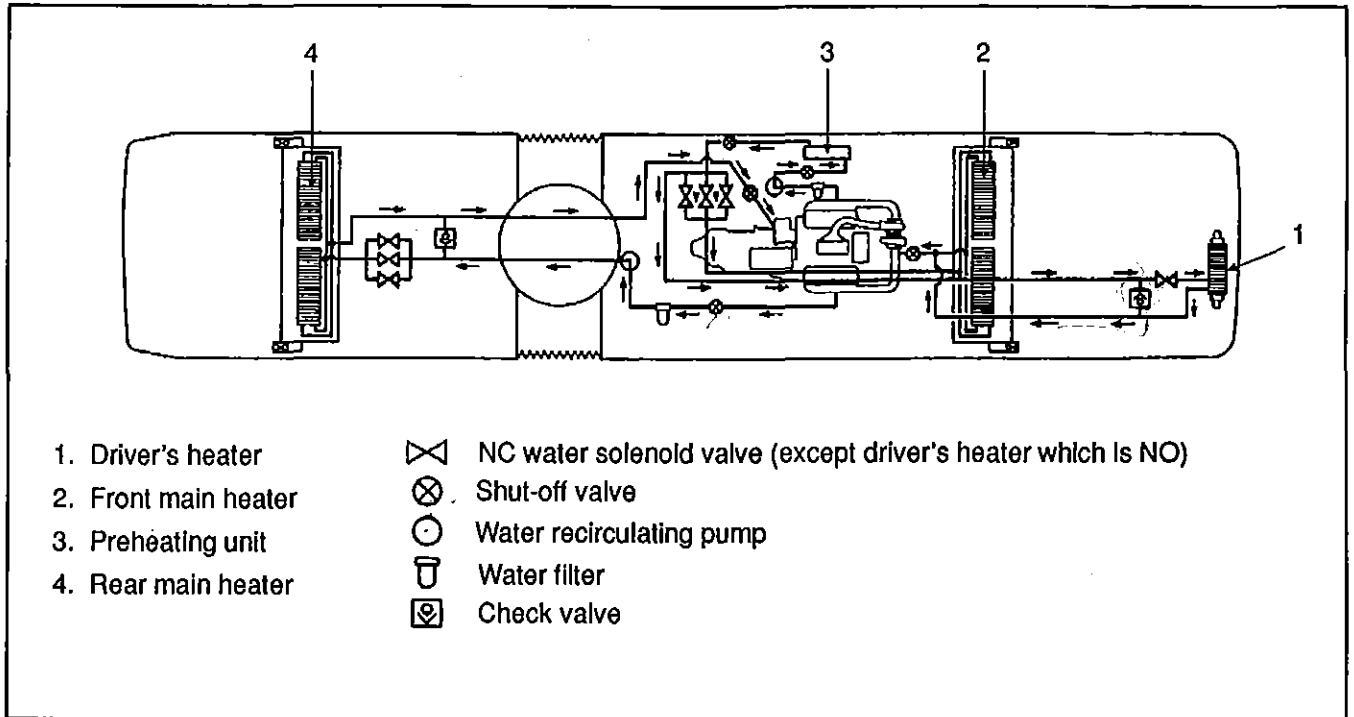

FIG. 23 - Heating system components

MAS-1623 IMG

## Draining heating system

### Main units

#### Front

1. Stop engine and allow engine coolant to cool.

**WARNING:** Never remove the filler cap immediately after stopping engine or during its operation. Boiling coolant may blow out and cause severe burns.

2. Remove the surge tank filler cap.

3. Remove the thirteen (13) bolts and washers securing the panel to the HVAC unit (see fig. 24).

4. Loosen clamp on the lower hose, separate hose from line, then direct hose in an appropriate container to recover coolant.

5. Open bleeder valve on upper section of heater core (see fig. 24).

6. The HVAC unit is provided with two (2) heater cores; thus, remove panel at other extremity of unit, then repeat previous steps to drain the other heater core.

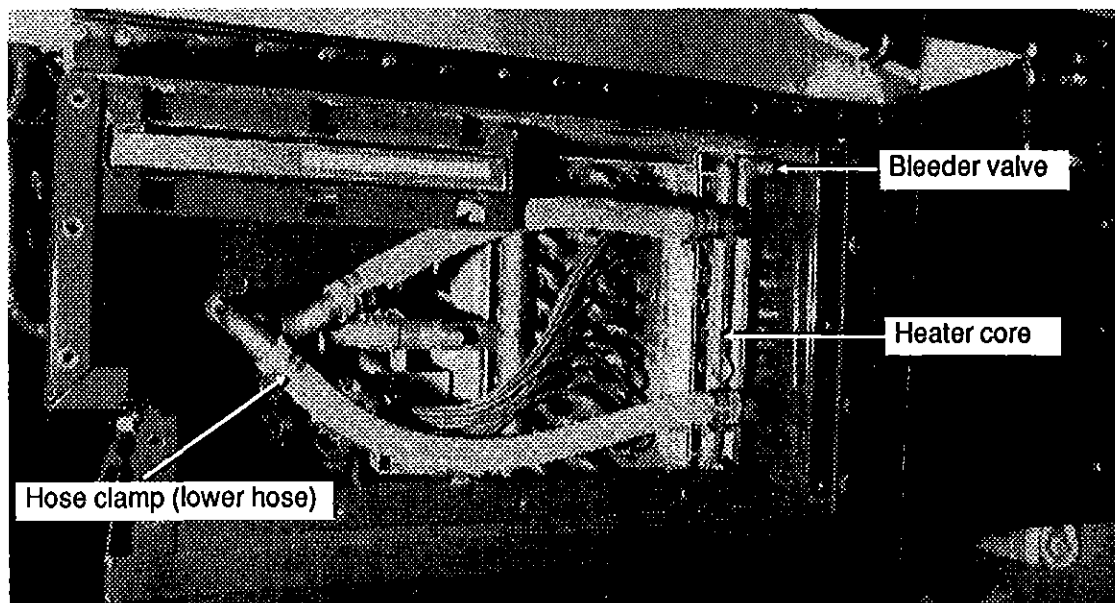

FIG. 24 - HVAC unit

MAS-1624 IMG

## Rear

The rear HVAC unit is identical to the front unit; follow the same draining procedure.

## Driver's unit

1. Stop engine and allow engine coolant to cool.

**WARNING:** Never remove the filler cap immediately after stopping engine or during its operation. Boiling coolant may blow out and cause severe burns.

2. Remove the surge tank filler cap.

3. Locate the normally-opened water solenoid valve on the ceiling of the compartment at rear of front bumper (see fig. 25), disconnect its wiring connector, then connect a 24 volt external power source, using jumper cables, to close valve.

4. Loosen hose clamp, install an appropriate container to recover coolant, then disconnect silicone hose from water solenoid valve.

5. From inside of vehicle, open the bleed valve on the coolant inlet line near the driver's heating unit (see fig. 26) to ensure an efficient draining.

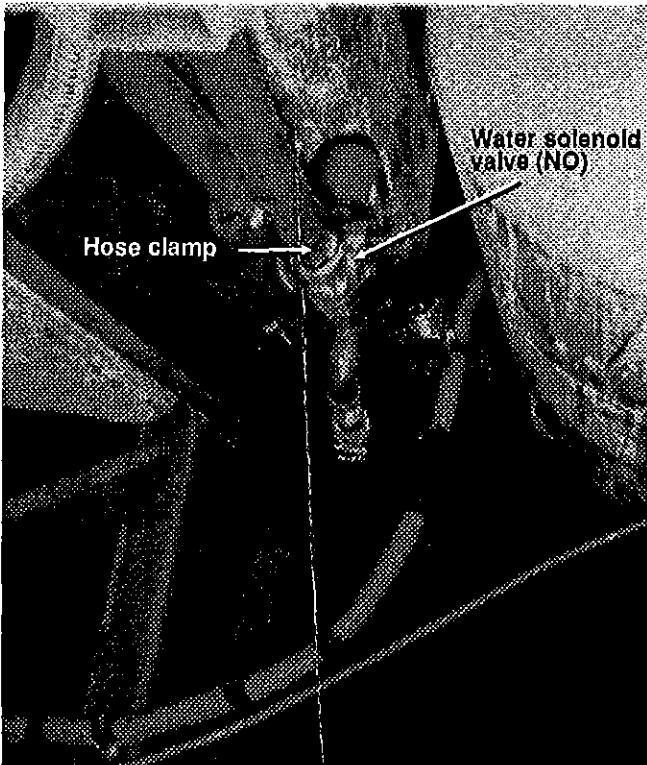

FIG. 25

MA5-1625.IMG

## Filling heating system

1. Ensure that all drain hoses are reconnected and bleed valves are closed.

2. Open the surge tank filler cap and slowly fill the system to level of filler neck.

3. After initial filling, the water solenoid valves should be opened and water recirculating pumps should be energized to assist in circulating coolant through the heating system. To perform this operation, start the engine, switch on the "Passenger A/C-heating" switch, then turn clockwise to their maximum position the three following controls: "Front section A/C-heating", "Rear section A/C-heating" and "Driver's A/C-heating temperature" in order to request the heating mode in each of these three zones.

4. When coolant level drops below the filler neck, slowly fill the system to level of filler neck.

5. Once level has been stabilized, replace surge tank filler cap.

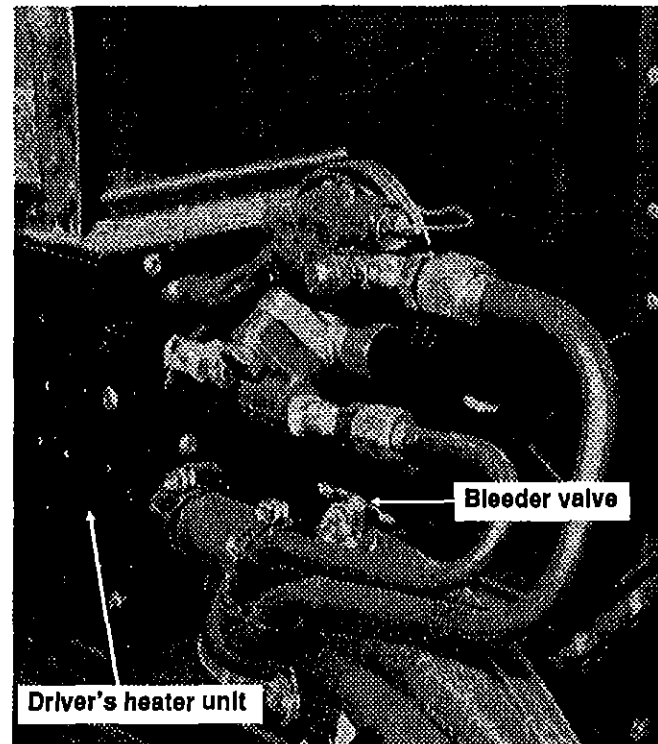

FIG. 26

MA5-1626.IMG

## Bleeding heating system

Whenever the heating system has been drained and refilled, or the system has run low of coolant and coolant has been added, it is necessary to bleed air from heating system. Bleed air from heating units according to the following procedure:

1. Refer to figures 24 and <sup>26</sup>25 to locate bleed valves.

**NOTE:** Each main HVAC unit is provided with 2 heater cores which operate independently from each other. Consequently, it is important to bleed air from the two (2) heater cores.

2. Open momentarily the bleed valve until no air escapes from the lines.

## HEATING SYSTEM COMPONENTS

### Water solenoid valves

#### Main heater

##### Description

Three (3) normally-closed water solenoid valves, connected in parallel, control the coolant flow through each of the two (2) main HVAC units. The three (3) valves controlling the water flow through the main front unit are located in the engine compartment right behind the radiator. The three (3) other valves for the rear unit are located on the ceiling of the second baggage compartment of rear section. To gain access to these valves, remove the Philipps head screws securing the panel to the compartment ceiling.

##### Manual bypass

This type of solenoid valve is equipped with a manual operating stem. The 3/16" square stem located on the bonnet is exposed when seal cap is removed (see fig. 27). To manually open valve, turn stem 1/2 turn counterclockwise. To manually close the valve, turn stem clockwise until tight against seat. Manual stem must be in closed position for automatic electric operation.

##### Maintenance

This type of valve, as regards its structure, is similar to the refrigerant solenoid valve; the dimensions and capacity are different. As for coil replacement, valve disassembly and reassembly, refer to the previous heading "Refrigerant solenoid valve".

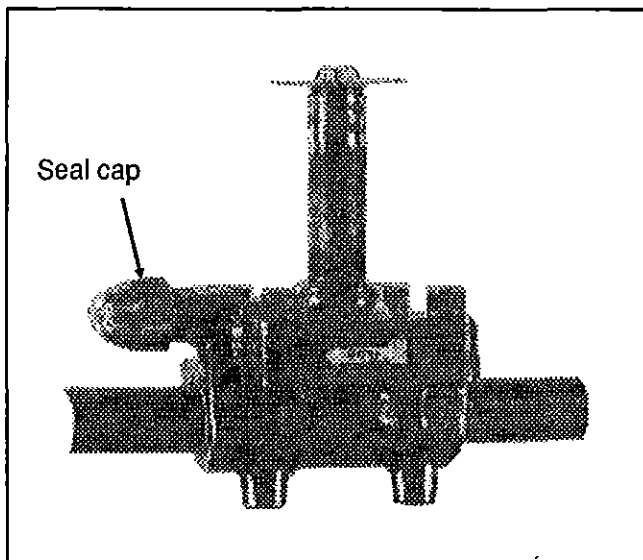

FIG. 27 - Water solenoid valve (without coil)

#### Driver's heater

##### Description

One (1) normally-open water solenoid valve is used to control the coolant flow through the driver's heating unit. The valve is mounted on the coolant inlet line of the driver's heating unit, and is accessible through the compartment at rear of the reclining bumper. The valve body and bonnet are made of brass; this valve can not be manually bypassed.

##### Improper operation

1. Faulty control circuit: Check the electric system by energizing the solenoid. A metallic clicking noise indicates that solenoid is operating; absence of clicking indicates a loss of power or a defective solenoid. Check for open breaker, open-circuited or grounded coil, broken lead wires.
2. Burned-out coil: Check for open-circuited coil. Replace coil if necessary.
3. Low voltage: Check voltage across the coil leads. Voltage must be at least 21 volts.
4. Excessive leakage: Disassemble valve and clean all parts. Replace worn or damaged parts with a complete spare parts kit for best results.

##### Coil replacement

1. Disconnect connector from coil connector.
2. Remove retaining clip, spacer, nameplate and housing (see fig. 28).

**WARNING:** When metal retaining clip disengages, it will spring upward.

3. Slip spring washer, insulating washer, coil and insulating washer off the solenoid base subassembly. Insulating washers are omitted when a molded coil is used.
4. Reassemble by reversing sequence of disassembly. Refer to exploded view for identification and location of parts.

**NOTE:** Solenoid must be completely reassembled, as the housing and internal parts are part of and complete the magnetic circuit. Place an insulating washer at each end of the coil, if required.

##### Valve disassembly

1. Drain driver's heating unit as explained under heading "Draining heating system" in this section.
2. Disassemble valve in an orderly fashion paying careful attention to exploded views (fig. 28) provided for identification of parts.
3. Remove retaining clip and slip the entire solenoid enclosure off the solenoid base subassembly.



**WARNING:** When metal retaining clip disengages, it will spring upward.

4. Unscrew solenoid base subassembly and remove core, plugnut gasket, plugnut assembly and solenoid base gasket.

5. Remove the four (4) bonnet screws, valve bonnet, disc holder subassembly, disc holder spring, diaphragm/spring subassembly and body gasket.

6. All parts are now accessible for cleaning or replacement. Replace worn or damaged parts with a complete spare parts kit for best results.

**CAUTION:** Do not damage valve seat in any manner, as its sealing feature will be affected, thus resulting in continuous leakage.

**Valve reassembly**

1. Reassemble by reversing sequence of disassembly paying careful attention to exploded views (fig. 28) provided for identification and location of parts.

2. Replace body gasket and diaphragm/spring subassembly. Locate bleed hole in diaphragm/spring subassembly approximately 45° from valve outlet.

**NOTE:** Should diaphragm/spring subassembly become disassembled, be sure to replace the diaphragm/spring support with lip facing upward towards the valve bonnet.

3. Replace disc holder spring and disc holder subassembly.

4. Replace valve bonnet and bonnet screws. Torque bonnet screws in a crisscross sequence to  $95 \pm 10$  inch-pounds ( $11 \pm 1$  N.m).

5. Install solenoid base gasket, plugnut assembly and plugnut gasket. Position core on plugnut assembly. Be sure plugnut assembly and core are installed with mating ends together.

6. Replace solenoid base subassembly and torque to  $175 \pm 25$  inch-pounds ( $20 \pm 3$  N.m).

7. Replace solenoid enclosure and retaining clip.

8. After maintenance, operate the valve a few times to be sure of proper opening and closing.

9. Refill heating system as previously stated under heading "Filling heating system", then bleed air from the driver's heating unit as stated previously under heading "Bleeding heating system".

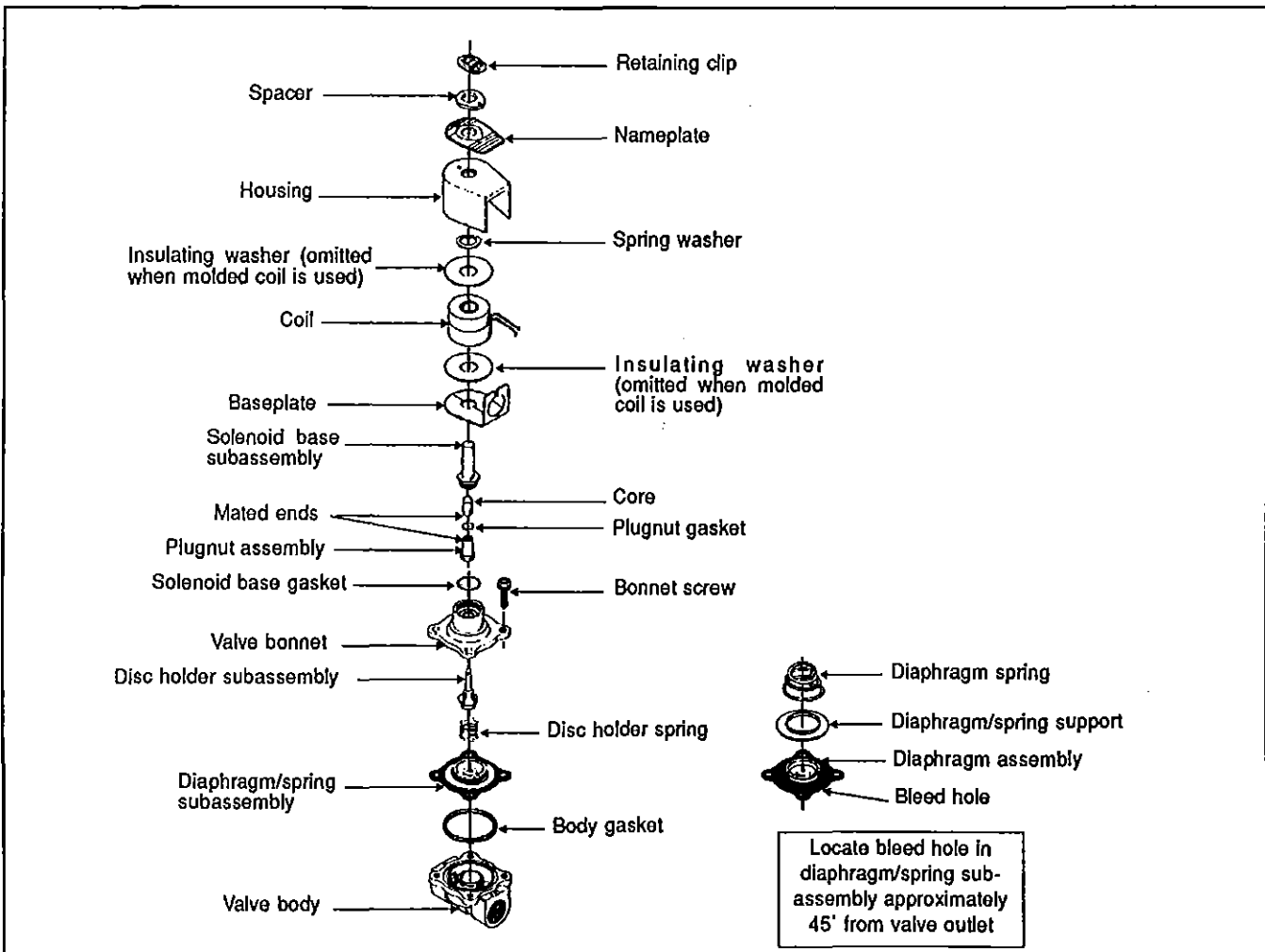

FIG. 28 - Water solenoid valve

MA5-1628, IMA3

## Water recirculating pump *-S-Text*

### Description *S-Text 1*

This vehicle is provided with two (2) identical water recirculating pumps, which are located in the engine compartment. The pump near the preheating system is used for the front and driver's heating units, while the other one at rear of compartment near the hydraulic system filter is used for the rear main heating unit. The water recirculating pump consists in a centrifugal pump and an electric motor, which are mounted on a common shaft in a compact assembly. A pilot between the pump end and motor cover ensures proper alignment of the complete assembly.

The motor is equipped with prelubricated sealed ball bearings which require no maintenance. A self-adjusting mechanical shaft seal is incorporated in this assembly to prevent coolant leakage between the pump cavity and armature shaft. This seal derives its lubrication from the liquid pumped, and it will be destroyed if permitted to operate dry.

This pump requires no periodic maintenance other than replacement of motor brushes. Replacement of motor brushes can be performed without removing the pump assembly. Visual inspection of the pump should be made while the pump is in operation to determine if the shaft seal is intact. If there is evidence of coolant leakage, the unit must be disassembled for corrective measures. Disassembly of the pump will be necessary only in the case of a seal leak, bearing failure, or motor failure.

### Removal *-S-Text 6*

#### Removing the front unit recirculating pump *S-Text 6*

1. Close shut-off valve on the line located between the pump and the preheating system.
2. Drain coolant from engine as stated in section 3 under heading "Draining cooling system".
3. Disconnect the electrical wiring from the motor.
4. Disconnect water lines from the pump at the flange connections.
5. Remove the two clamps holding the pump motor to its mounting bracket. Remove the pump with the motor as an assembly.

#### Removing the rear unit recirculating pump

Unlike the recirculating pump of the front heating units, the rear unit pump is located in the upper section of engine compartment; consequently, there is no need to drain engine coolant or close any shut-off valve to remove the pump. Perform only steps 3 to 5 under previous heading; loss of coolant will be minor.

#### Disassembly (refer to fig. 29) *S-Text 1*

1. Remove two brush caps (3) and two brush and spring assemblies (4). When removing brushes, note the position of the brush in the tube. Brush life is significantly decreased if brushes are not replaced properly.
2. Remove the pump cover (12) by removing eight (8) fillister head screws. Remove cover carefully to prevent damage to gasket (10).
3. Remove gasket (10).
4. Remove two hex nuts and lockwashers which hold pump assembly to the motor.
5. Remove the pump from the motor as follows:
  - a) Install puller tool assembly (MP Co. Part No. 24702 or equivalent) to pump body (8) using four screws removed from the pump cover (12).
  - b) Tighten the puller screw to press the motor shaft out of the impeller hub. The pump is now free of the motor.
6. Remove the puller tool.
7. Remove impeller (11) and components of the pump seal assembly (15) and seal seat assembly (16).

**CAUTION: Do not scratch or mar the sealing surface of this seat, as its sealing feature will be affected, thus resulting in continuous leakage.**

#### Pump inspection *-S-Text 1*

Components removed from the recirculating pump and motor assembly should be compared with new parts to determine the degree of wear.

#### Brushes *S-Text 2*

1. When removing brushes, note the position of the brush in the tube. Brush life is shortened if the brushes are not replaced properly.

2. Examine brushes for the following:

##### a) Wear

Replace the brushes if less than 25% of the usable brush is left (less than 0.300" (8 mm)).

##### b) Chipped edges

Chips can be caused by improper handling or installation. Badly chipped brushes should be replaced regardless of their length.

c) Annealed brush spring

This can be detected by noting the resiliency of the spring. Annealing is caused by failing to tighten the brush caps properly, thus not providing a good low resistance contact between the terminal and the brush tube. Replace brushes showing evidence of annealed springs.

d) Frayed or broken pigtail

An improperly installed brush may have the pigtail (shunt) pinched under the terminal or between the coils of the spring. If the pigtail is badly frayed or broken, replace the brush.

3. Observe the following factors when replacing brushes:

a) The face of a new brush is carefully cut to cause proper seating during the "wear-in" period.

b) Improper installation can harm both the brush and the commutator.

c) Replacement brushes should be of the proper grade.

d) New brushes have a 6 degree angle on the brush face. The brush should always be inserted so that the angle is open away from the pump end of the assembly (see inset, fig. 29).

e) Brush performance will be affected if the spring and terminal are not properly placed in the brush tube. The spring should be free over its entire length and the terminal should make good contact with the metal brush tube insert.

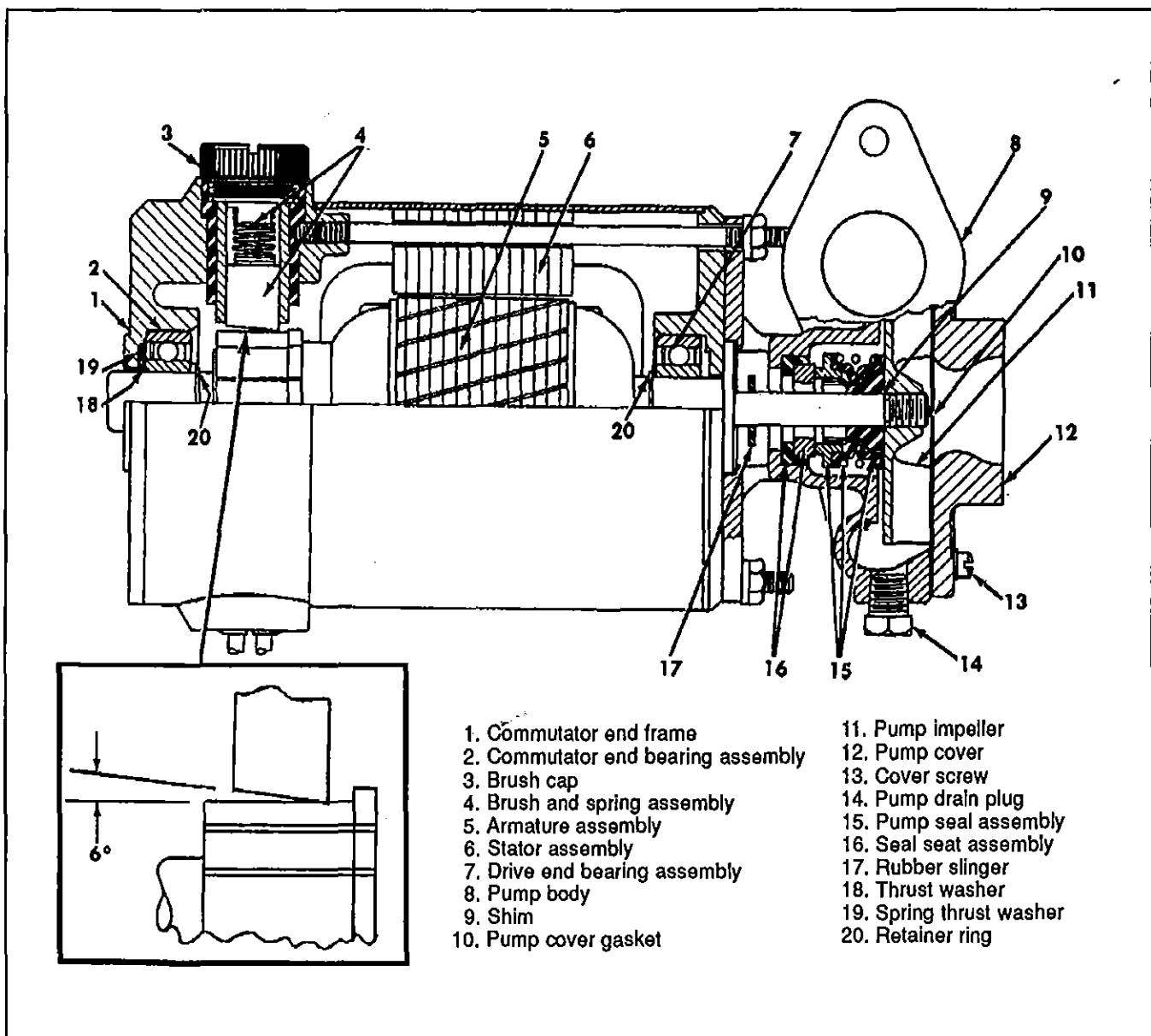

- |                                    |                          |
|------------------------------------|--------------------------|
| 1. Commutator end frame            | 11. Pump impeller        |
| 2. Commutator end bearing assembly | 12. Pump cover           |
| 3. Brush cap                       | 13. Cover screw          |
| 4. Brush and spring assembly       | 14. Pump drain plug      |
| 5. Armature assembly               | 15. Pump seal assembly   |
| 6. Stator assembly                 | 16. Seal seat assembly   |
| 7. Drive end bearing assembly      | 17. Rubber slinger       |
| 8. Pump body                       | 18. Thrust washer        |
| 9. Shim                            | 19. Spring thrust washer |
| 10. Pump cover gasket              | 20. Retainer ring        |

FIG. 29 - Water recirculating pump and motor

MAS-1629.IMG

**Bearings** (fig. 29) *S-Table 2*

1. Rotate the motor shaft. If the ball bearings show evidence of wear, they should be replaced.
2. When removing the armature from the motor, the number of washers and their arrangement should be noted. Improper number or installation of washers can cause improper tracking of brushes, which will result in excessive preloading of bearings and noisy operation. Position spring thrust washer (19) and retainer ring (20) as shown.
3. The use of a bearing puller is recommended when removing the bearings to help prevent damaging the armature winding or the commutator.
4. Replacement bearings should be pressed in to the same exact location as the original bearings.
5. It is recommended that a suitable sealant (such as Loctite or equivalent) be used between the shaft and the bearing, if the fit is not tight enough to prevent the shaft from spinning inside the inner race.
6. After replacing the bearings, check the position of the commutator in the motor by looking down into the brush tube. Neither the riser nor the edge of the commutator should be visible.

**Commutator** *S-Table 2*

1. The commutator is a precise assembly. Although it is solidly built of a fairly tough material, it can be easily ruined by careless handling.
2. The commutator should be refinished only on equipment which will provide good concentricity and the proper finish.
3. The commutator should be refinished if a micrometer reading shows a difference between "in track" and "off track" diameter of 0.0187" (4,7 mm) or more.
4. The commutator should be carefully undercut with a 0.025" (0,6 mm) or less slot width.
5. A 25 to 50 micromesh finish is desirable on a new or refinished commutator.
6. The commutator should not be touched with the fingers since sweat and body oils will rapidly discolor and oxidize the surface.

**Miscellaneous** *S-Table 2*

1. Check the rubber shaft slinger (17) to make sure it is tight on the motor shaft. If the slinger slips on the shaft, it should be replaced.
2. Inspect seal assemblies (15) and (16) to determine wear. If the seal has leaked, or is badly worn, it is recommended that a complete new seal assembly be installed.

3. The impeller (11) is a press fit on the armature shaft. This press fit must be maintained to prevent the impeller from slipping. Install a new impeller if necessary.

**Assembly** *S-Table 2*

1. Install floating seal seat (16) in pump body (8) in the following manner:
  - a) Clean the seal seat in a suitable cleaning solvent to remove dust or dirt.
  - b) Insert the seat in the proper recess in the pump body. This is a snug fit, but a drop of machine oil or a small amount of clean grease applied only to the neoprene ring and to the body cavity will ensure easy installation. Be sure the seat bottoms in the pump body around its entire circumference.
2. Install slinger (17) on the motor shaft.
3. Assemble body (8) to the motor.
4. Lubricate the pump shaft with a small amount of light oil, then slip the seal bellows and washer assembly (15) onto the shaft, so that the seal washer contacts the seal seat (16) in the pump body (18).
5. Install impeller (11) in the following manner:
  - a) Place the impeller on a flat surface with the vanes against the flat surface.
  - b) Invert the motor and pump body assembly, then pilot the pump shaft into the impeller bore. **Do not hammer** on the motor shaft extension at rear of the motor.
  - c) Press on motor and pump body until the machined face of the pump body is flush with the face of the flat surface on which the impeller is resting. The face of the impeller vanes must now be flush with the machined face of the pump body.
6. Install gasket (10). This gasket is 0.010" (0,25 mm) thick and serves both to seal the cover and to establish the proper clearance between the face of the impeller and the pump cover.
7. Attach cover (12) to the pump body using eight (8) fillister head screws (13).
8. Install motor brushes (4) and brush caps (3), observing the precautions mentioned previously under step 3 in "Inspection" procedure.

**Installation** *S-Table 2***Replacing the front unit recirculating pump**

1. Apply gasket cement to the pump body line adapter and to the line flanges, put in place the two (2) gaskets, then connect water lines from the pump at the flange connections. Position the pump and motor assembly on the mounting bracket, and position the mounting clamps over the motor and secure with mounting bolts.
2. Connect electrical wiring to the pump motor.

3. Open shutt-off valve located on the line routed from the pump to the preheating system.
4. Fill the cooling system as previously instructed in section 3 under "Refilling cooling system".

### Replacing the rear unit recirculating pump

1. Repeat steps 1 and 2 under previous heading "Replacing the front unit recirculating pump".
2. If for any reason whatsoever, coolant loss was significant, fill the cooling system as previously instructed in section 3 under "Refilling cooling system", then bleed air from rear heating unit as previously instructed in this section under "Bleeding the heating system".

## Water filters

### Description

This vehicle is provided with two (2) identical and cleanable water filters, which are both located in the engine compartment. The filter located near the preheating system, filters the liquid flowing to the main front heating unit and to the driver's heating unit, while the other one, located at rear of compartment near the hydraulic system filter, filters the liquid flowing to the rear heating unit. The filter element uses the micronic principle of filtration which utilizes a resin impregnated cellulose and an accordion pleated design for a maximum filtering area. A relief valve integrated to the filter element allows bypass of the filter in case it would be seriously restricted (see fig. 30).

### Maintenance

The filter maintenance consists in an initial cleaning after the first 3000 miles (4 800 km), and subsequently, every 100,000 miles (160 000 km).

**NOTE:** Each time <sup>SOLDERING</sup> welding is performed on any water pipe of the heating system, operate heating system a few minutes so that any foreign matter will be routed to the filters. Clean filters.

### Cleaning procedure

Before cleaning the filter located near the preheating system, lower coolant level as instructed in section 3 under heading "Draining cooling system". This operation is not required for the other filter; however, ensure that coolant has cooled before starting procedure.

1. Unscrew the filter casing with a 1 1/4" open end wrench.
2. Remove filter element, then clean inside of casing.
3. Using water under pressure, flush the element from inside towards the outside.
4. Replace element in casing, ensure that gasket and O-ring are still in place, then tighten casing on its cover.

5. Correct coolant level in surge tank as instructed previously in this section under "Filling heating system".

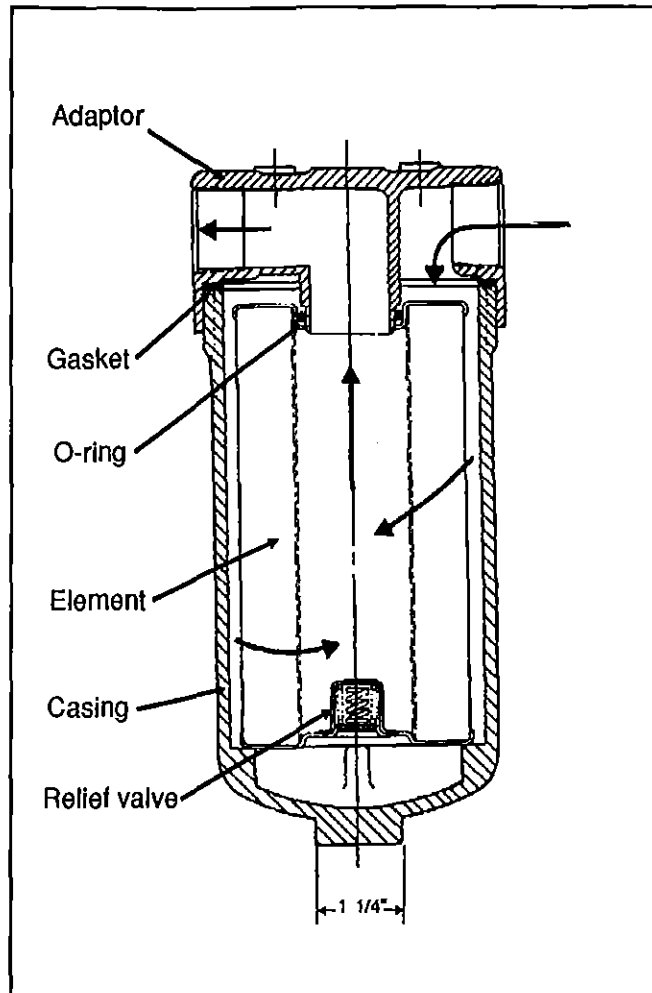

FIG. 30 - Water filter

MA5-1630JMG

## Preheating system

### Description

An auxiliary preheating system is used to preheat and maintain the heat in the engine coolant. The preheater works in conjunction with the heating system of the vehicle, which heats the interior of the coach.

The preheater operates independently of the vehicle engine. It is connected to the cooling and heating circuits, the fuel supply system and the vehicle electrical system.

The preheater contains a high pressure fuel nozzle and is thermostatically controlled, thus operating intermittently. It is switched "On" and "Off" by a rocker switch on the L.H. side lower control panel. An indicator light is fitted on the dashboard, to provide a visual indication of operation. When the preheater is switched on, the operation indicator light illuminates, the combustion air fan, the fuel pump and the water recirculating pump begin to run. After a period of about 15 seconds, fuel is sprayed into the combustion chamber through the high pressure nozzle, and is simultaneously ignited by a high tension spark. A photocell turns the ignition unit off after combustion has established.

If the combustion has not been established 30 seconds after the preheater was switched on, or if the flame goes out for more than 10 seconds during operation, the heater is switched off automatically. A breakdown switching also occurs when the heater is overheated and the temperature fuse melts, or in case of undervoltage. After correcting the cause of the malfunction, the heater can be restarted by first switching it "Off" and then switching it "On" again.

When operating temperature has been reached, the control thermostat is actuated and regulates the temperature by switching the heater "On" and "Off", and ensuring the temperature of the coolant remains at a constant level. If the temperature rises above the highest switching point of the control thermostat, the solenoid valve shuts off the fuel supply, thus extinguishing the flame. The purging cycle follows, while the combustion air blower and the fuel pump continue to operate for about 150 seconds, switching off automatically afterwards.

The water recirculating pump remains in operation during regulated intervals. The indicator light remains on. If temperature drops below the lowest switching point of the control thermostat, the starting procedure of the preheater will resume.

When the preheater is switched off, combustion stops. The operation indicator light goes out and the purging cycle begins. When this is completed, the water recirculating pump switches off independently.

It is permissible to switch the preheater on again during the purging cycle.

### Maintenance

For the maintenance and troubleshooting of this device, refer to the "*Webasto handbook*" at the end of this section. As for the preheater fuel filter and line servicing, refer to heading "*Preheater filter servicing (Webasto)*" in section 02 "*Fuel system*".

## SPECIFICATIONS

### CONTROL MODULE

Make . . . . . Honeywell  
 Model . . . . . W973B  
 Voltage rating . . . . . 24 volts  
 Switching (on-off stages) . . . . . Pilot duty spdt relays  
 Input signal (from printed circuit board) . . . . . to 16 V DC  
 Supplier number . . . . . W973B1016  
 Prévost number . . . . . 56-1805

### PRINTED CIRCUIT BOARD

Make . . . . . Honeywell  
 Model . . . . . T7067B (modified by Prévost)  
 Voltage rating . . . . . 20 volts (from control module)  
 Current draw . . . . . 20 milliamperes  
 Output signals . . . . . Two 1-16 volt signals (one each for cooling and heating) to control module  
 Output signal rate of change (upon deviation from set point) . . . . . 2.5 V DC/1 °F (0,5 °C)  
 Supplier number . . . . . T7067B1006  
 Prévost number . . . . . 38-0877

### FRESH AIR INLET SENSOR

Make . . . . . Honeywell  
 Model . . . . . C7046A  
 Sensing element . . . . . Carbon type, thermistor-resistor element  
 Nominal resistance . . . . . 3000 ohms at 77 °F (25 °C)  
 Nominal sensitivity . . . . . 70 ohms/°F (124 ohms/°C) at midrange  
 Supplier number . . . . . C7046A1004  
 Prévost number . . . . . 95-0082

### RETURN AIR SENSOR

Make . . . . . Honeywell  
 Model . . . . . T7047C  
 Supplier number . . . . . T7047C1025  
 Prévost number . . . . . 95-0088

### DISCHARGE AIR SENSOR

Make . . . . . Honeywell  
 Type . . . . . Non-adjustable thermistor sensor  
 Nominal resistance . . . . . 1420 ohms at 75 °F (24 °C)  
 Nominal sensitivity . . . . . 15 ohms/ °F (25 ohms/ °C) resistance increases as temperature falls  
 Supplier number . . . . . T7022A1010  
 Prévost number . . . . . 56-1806

**HVAC UNIT ASSY**

Make . . . . . Carrier Transicold  
 Supplier number . . . . . 62G2-1194  
 Prévost number . . . . . 95-0084

**MAIN HVAC UNIT BLOWER MOTORS**

Make . . . . . LeRoy-Somer  
 Type . . . . . Tap-12 permanent magnet  
 Voltage . . . . . 27.5 V DC  
 Current draw . . . . . 25 amps  
 Horsepower . . . . . 0.85  
 Revolution . . . . . 1950 rpm  
 Insulation . . . . . Type F  
 Brush life . . . . . 10 000 hours  
 Supplier number . . . . . Tap-12  
 Prévost number . . . . . 56-1558  
 Brush supplier number . . . . . 2.100.330  
 Brush Prévost number . . . . . 56-1914

**HVAC UNIT AIR FILTERS**

Make . . . . . Carrier Transicold  
 Type . . . . . Disposable  
 Supplier number . . . . . 38-00143-00  
 Prévost number . . . . . 87-0951

**DRIVER'S HEATER UNIT ASSEMBLY**

Make . . . . . Prévost  
 Prévost number . . . . . 37-2320

**DRIVER'S HEATER UNIT BLOWER MOTORS**

Make . . . . . Aurora  
 Type . . . . . RG500EF  
 Voltage . . . . . 24 V DC  
 Supplier number . . . . . 001.58.04  
 Prévost number . . . . . 56-1194

**DRIVER'S HEATER UNIT AIR FILTER**

Make . . . . . Spall-Bowman  
 Type . . . . . Permanent washable aluminum filter  
 Supplier number . . . . . N/A  
 Prévost number . . . . . 87-0840



**REFRIGERANT**

Type . . . . . Freon 22 (monochlorodifluoromethane)  
 Quantity . . . . . 44 lbs (20 kg)

**COMPRESSOR**

Make . . . . . Carrier Transicold  
 Model . . . . . 05G  
 No. of cylinders . . . . . 6  
 Bore . . . . . 2" (50,8 mm)  
 Stroke . . . . . 1-15/16" (49,2 mm)  
 Operating speed . . . . . 400 to 2200 rpm (1750 rpm, nominal)  
 Minimum speed (for lubrication) . . . . . 400 rpm  
 Nominal horsepower . . . . . 25  
 Oil pressure at 1750 rpm . . . . . 15 to 30 psi (103-207 kPa)  
 Oil capacity . . . . . 1.13 U.S. gal (4,3 liters)  
 Weight . . . . . 142 lbs (64,5 kg)  
 Approved oils:  
 - Calumet . . . . . R030  
 - Dupont . . . . . Zephron 150  
 - Sun oil Co. . . . . Suniso 3GS & Suniso 4GS  
 - Texaco . . . . . WFI 132  
 Supplier number . . . . . 05GC037310  
 Prévost number . . . . . 95-0097

**COMPRESSOR UNLOADER**

Make . . . . . Carrier  
 Type . . . . . Electric (AMC)  
 Voltage . . . . . 24 V DC  
 Watts . . . . . 15  
 Supplier number . . . . . 22-50030  
 Prévost number . . . . . 95-0096

**COMPRESSOR V BELTS**

Make . . . . . Gates  
 Model . . . . . V80 (288D)  
 Supplier number . . . . . CX 85  
 Prévost number . . . . . 50-6600  
 Quantity . . . . . 2

**MAGNETIC CLUTCH**

Make . . . . . Carrier Transicold  
 Type . . . . . Housing mounted 9" dia., 2-C groove  
 Voltage . . . . . 24 V DC  
 Coil resistance at 68 °F(20 °C) . . . . . 5.15 - 5.69 ohms  
 Supplier number . . . . . 50-01122-01  
 Prévost number . . . . . 95-0094

**TIME DELAY MODULE**

Make . . . . . Artisan Electronic  
 Delay time . . . . . 50 sec.  
 Exterior resistance . . . . . 470 kilohms  
 Supplier number . . . . . 438U  
 Prévost number . . . . . 56-0772

**CONDENSER COIL**

Make . . . . . Carrier Transicold  
 Tubing . . . . . 3/8" copper  
 Rows . . . . . 5 rows, 5 circuits  
 . . . . . 2 rows for sub-cooling  
 Fins . . . . . .008 aluminum (or .006 copper optional)  
 . . . . . 9 per inch  
 . . . . . Corrugated with straight edge  
 Supplier number . . . . . N/A  
 Prévost number . . . . . 45-9042 (aluminum type)  
 . . . . . 45-1465 (copper type)

**RECEIVER TANK**

Make . . . . . Standard Refrigeration  
 Supplier number . . . . . 45-1382  
 Prévost number . . . . . 45-1382

**FILTER DRYER ASSEMBLY**

Make . . . . . Purolator  
 Supplier number . . . . . 0F-12-10  
 Prévost number . . . . . 87-0834  
 Element supplier number . . . . . 0F-2-10  
 Element Prévost number . . . . . 87-0835

**REFRIGERANT SOLENOID VALVE**

Make . . . . . Parker  
 Type . . . . . Normally-closed with manual bypass  
 Nominal capacity with R-22 . . . . . 5 tons  
 Voltage . . . . . 24 V DC  
 Amperage draw . . . . . 0.67 amps  
 Watts . . . . . 16  
 Supplier number (without coil) . . . . . RB9ME5-MM  
 Prévost number (without coil) . . . . . 95-0087  
 Coil supplier number . . . . . R23MM-CB 24 V DC  
 Coil Prévost number . . . . . 95-0055

**HUMIDISTAT**

Make . . . . . Honeywell  
 Model . . . . . H402A  
 Scale range . . . . . 15 to 60 percent relative humidity with OFF and ON position  
 Sensing element . . . . . A thin (1 mil) moisture sensitive nylon ribbon  
 Supplier number . . . . . H402A1023  
 Prévost number . . . . . 56-1803

**CONDENSER FAN HYDRAULIC MOTOR**

Make . . . . . Vickers  
 Supplier number . . . . . M2U-1S18S-1C10  
 Prévost number . . . . . 95-0072

**HYDRAULIC PUMP**

Make . . . . . Vickers  
 Model . . . . . V10  
 Ring capacity at 1200 rpm and 100 psi (689,5 kPa) . . . . . 6 U.S.gal/min. (22,7 l/min.)  
 Supplier number . . . . . V10-1S6S1C20L  
 Prévost number . . . . . 95-0070

**HYDRAULIC PUMP V BELTS**

Make . . . . . Gates  
 Type . . . . . Super HC  
 Supplier number . . . . . 3V450  
 Prévost number . . . . . 50-6317  
 Quantity . . . . . 2

**OIL COOLER**

Make . . . . . Kool-Mor  
 Type . . . . . Copper tube with aluminum fins  
 Supplier number . . . . . DB-1240  
 Prévost number . . . . . 95-0109

**SOLENOID CONTROL RELIEF VALVE**

Make	Vickers
Voltage	.24 V DC
Current draw	1.7 amps
Watts	41
Relief valve adjustment	1250 psi (8 618 kPa)
Resistance at 68 °F (20 °C)	13.9 ohms
Supplier number	CS5-030A-C-MPA3-W-H-90
Prévost number	.95-0071

**HYDRAULIC OIL FILTER**

Make	Vickers
Type	Disposable cartridge
Filter size	10 microns
Supplier number	573082
Prévost number	.66-0671

**WATER SOLENOID VALVES (MAIN HEATER)**

Make	Parker
Type	Normally-closed with manual bypass
Voltage	.24 V DC
Amperage draw	0.67 amps
Watts	.16
Supplier number (without coil)	RB21ME7-MM
Prévost number (without coil)	.87-0886
Coil supplier number	R23MM-CB 24 V DC
Coil Prévost number	.95-0055

**WATER SOLENOID VALVE (DRIVER'S HEATER)**

Make	Asco
Type	Normally-open (without manual bypass)
Voltage	.24 V DC
Current draw	0.47 amps
Watts	11.2
Supplier number (with coil)	106-269-1
Prevost number (with coil)	.87-0812
Coil supplier number	27-463-4
Coil Prévost number	.87-0960

**WATER RECIRCULATING PUMP**

Make . . . . . M.P. pumps  
 Model . . . . . 12300  
 Voltage . . . . . 24 V DC  
 Current draw . . . . . 5.3 amps  
 Revolution . . . . . 3000 rpm  
 Supplier number . . . . . 22023  
 Prévost number . . . . . 87-0871

**WATER FILTER ASSEMBLY**

Make . . . . . Purolator  
 Type . . . . . 0F-15F ("T" type)  
 Relief valve setting . . . . . 17-19 psi (117-131 kPa)  
 Filter size . . . . . 10 microns  
 Filtering area . . . . . 430 sq.in. (2 774,188 cm<sup>2</sup>)  
 Supplier number (with element) . . . . . 0F-12-10  
 Prévost number (with element) . . . . . 87-0834  
 Element supplier number . . . . . 0F-2-10  
 Element Prévost number . . . . . 87-0835

**PREHEATING SYSTEM**

Make . . . . . Webasto  
 Type . . . . . High-pressure nozzle  
 Model . . . . . DBW 300.24  
 Capacity . . . . . 103 000 BTU/hr  
 Rated voltage . . . . . 24 V DC  
 Operating voltage . . . . . 20-28 V DC  
 Rated input (without water recirc. pump) . . . . . 130 watts  
 Fuel consumption . . . . . 6.7 U.S. plnts/hr (3,2 l/hr)  
 Supplier number . . . . . 475718  
 Prévost number . . . . . 87-0893

**17**

**BODY**









# 18

# ACCESSORIES

## CONTENTS OF THIS SECTION

HUBODOMETER . . . . .	18-1
SOUND SYSTEM . . . . .	18-1
SOUND SYSTEM TROUBLESHOOTING . . . . .	18-3
BACK-UP CAMERA . . . . .	18-3
MONITOR . . . . .	18-5
TACHOGRAPH . . . . .	18-5
COMFORT LEVEL INDICATOR . . . . .	18-6
COLD STARTING AID (ETHER) . . . . .	18-7
DESTINATION SIGN . . . . .	18-9
LAVATORY . . . . .	18-10
SPECIFICATIONS . . . . .	18-17



## HUBODOMETER

### Description

A wheel hubodometer (see fig. 1) is installed on the R.H. side of the fourth axle, and indicates the total distance in miles or kilometers covered by the coach since it has left the factory, including road testing.

### Operation

The hubodometer is calibrated for a specific wheel size (diameter). Wheel rotation causes a mechanism inside the hubodometer to record distance after a predetermined number of rotations. The unit should be serviced at a competent speedometer repair facility.

### Hubodometer removal

To remove the unit, remove the two nuts and lock washers that secure it to the wheel hub. Pull the unit off the studs.

### Hubodometer installation

Place the hubodometer unit over the wheel hub studs. Replace the lock washers and nuts. Torque stud nuts to 130-170 foot-pounds (177-231 N.m).

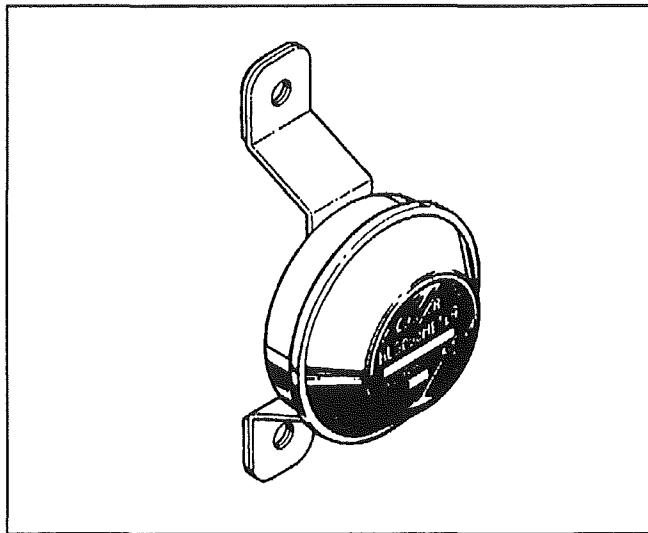

FIG. 1 - Hubodometer

OPH56023.IMG

## SOUND SYSTEM

The sound system consists of:

- Sixteen (16) Hi-Fi speakers.
- Two (2) additional Hi-Fi front speakers with stereo attenuator (for the driver).
- Blaupunkt AM/FM stereo cassette receiver.
- Two (2) 80 watt amplifiers.
- Public address system with volume control attenuator, including 2 microphone outlets in front section. Additional microphone outlets may have been installed as optional equipment.

**NOTE:** Before attempting to solve an electrical problem on the sound system, refer to diagram # 24/24 of the master wiring diagrams and to the "Sound system troubleshooting guide" later in this section.

### AM/FM stereo cassette receiver

Instructions for proper use of the radio are included in the technical publication box delivered with the vehicle. The radio is a serviceable component and should only be serviced by a qualified electronics technician. Refer to "Blaupunkt Service Centers" manual included in the technical publication box.

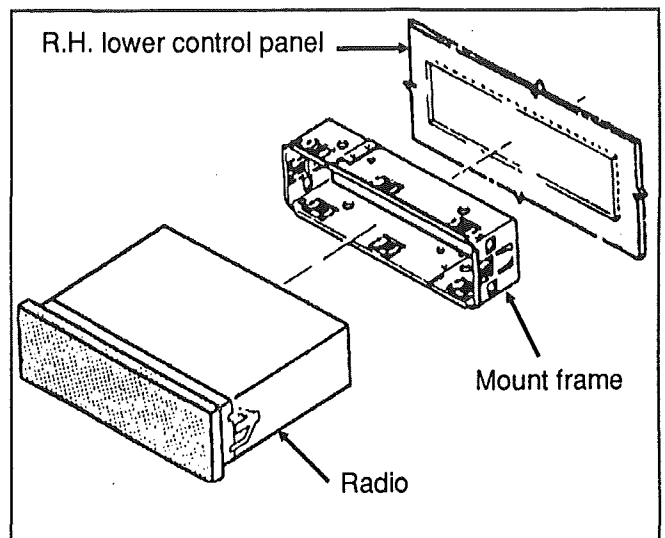

FIG. 2 - Radio Installation

MA5-1802.IMG

To remove radio from the dash, use dismantling brackets included in the technical publication box delivered with the vehicle. Insert two dismantling brackets in four holes on both sides of the radio until they firmly lock in position, then pull on both dismantling brackets to remove unit from the dash. Refer to figure 3 for more details. Disconnect the antenna and all other wiring connectors at back of the radio.

**NOTE:** Each time the vehicle batteries or the wiring connectors at back of radio are disconnected, the radio memory has to be reprogrammed according to the radio instruction manual.

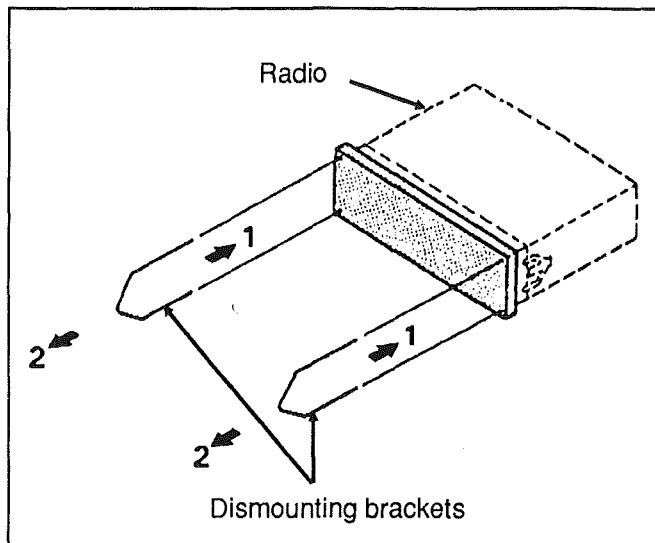

FIG. 3

MA5-1803.IMG

## Amplifiers

Two 80 watt amplifiers are provided for the sound system. Both are located over the driver's compartment and on front of the left parcel rack (see fig. 4). Remove the amplifiers as follows:

1. Set the battery main disconnect switches to the "OFF" position.
2. From the driver's compartment, locate the driver's dome light panel (see fig. 4).
3. Remove the four (4) snap caps and retaining screws from the driver's dome light panel, remove panel from its location and let it hang by the wires.
4. Remove the screws retaining the amplifiers to their mounting bracket, disconnect wiring connectors from amplifiers, then remove amplifiers from their location.
5. Reverse the above procedure to install the amplifiers.

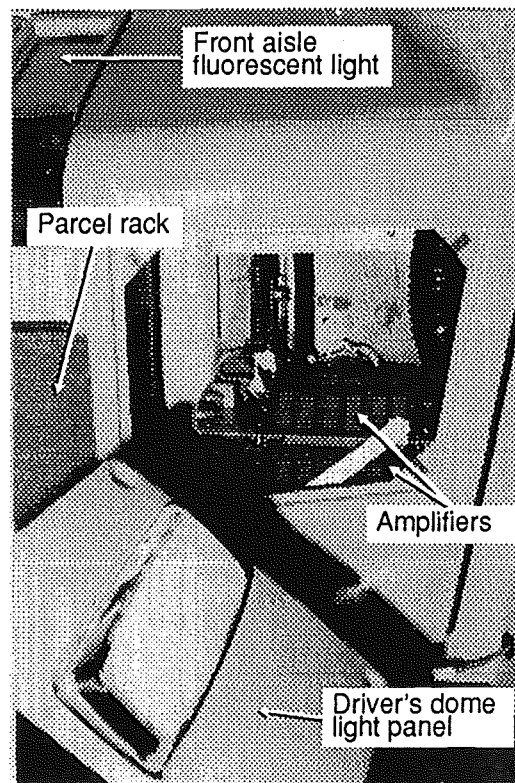

FIG. 4 - (View from under)

MA5-1804.IMG

## Public address control box (PA)

The public address control box is located in the left corner at driver's feet. Four (4) cartridge-type fuses are mounted in external holders of the box and may be checked without removing the box from its location (see fig. 5). To remove a fuse, unscrew the fuse cap, then remove the fuse from its holder with the cap as the cap is removed. The fuse may then be pulled from the cap. Always replace a fuse with a fuse of the same type and rating.

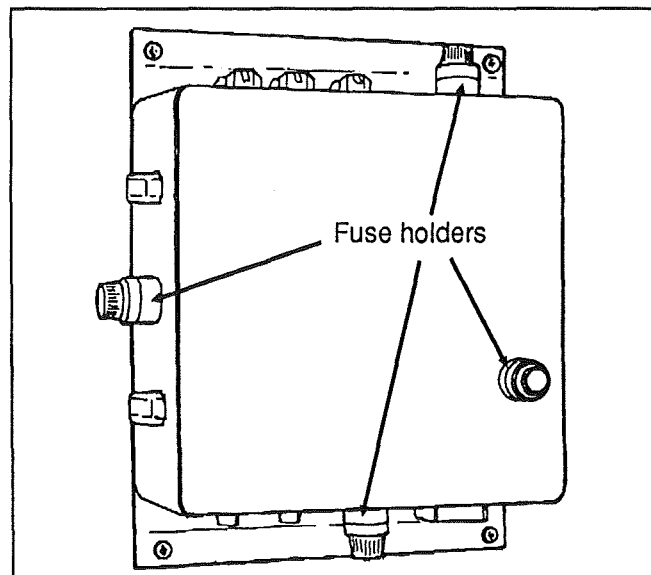

FIG. 5 - Public address control box

MA5-1805.IMG

## SOUND SYSTEM TROUBLESHOOTING

MALFUNCTION	POSSIBLE CAUSE	CORRECTIVE MEASURE
High-frequency continuous noise.	Speaker circuit grounded to the structure.	Locate and insulate wire grounded to the structure.
Auxiliary microphone outlet inoperative.	Faulty wiring inside P/A unit connector.	Replace P/A unit.
Extensive difference between driver's and passenger's speakers when speaker selection switch is activated.	"Fader" incorrectly set.	Push radio "Fader" control and turn to set required balance.
Malfunction of additional microphone outlet(s).	May be incorrect wiring in Y-connector of additional microphone outlet(s).	Verify Y-connector wiring.
Sound level in rear section is lower than in front section.	Output level of amplifier for rear section is not adjusted properly.	Readjust gain by turning clockwise the "Gain Adj." to the proper level.

## BACK-UP CAMERA

### General description

A back-up camera and monitor are provided as standard equipment. When the driver selects the reverse range, the camera and monitor will automatically switch on, thus allowing driver to view behind the vehicle. The monitor will switch off after the reverse range has been released.

The camera is retractable and is visible from the outside only when it is functioning. A switch located in a small compartment on the R.H. side of rear section stepwell (see fig. 6), enables the extension of the camera for maintenance or cleaning purpose. The camera enclosure is insulated with a thick foam, and a heating strip (52 watts) is wound around the camera and is controlled by a thermal switch. The camera is fed from the 12 volt circuit; for specific wiring information, refer to diagram # 22/24 of the master wiring diagrams.

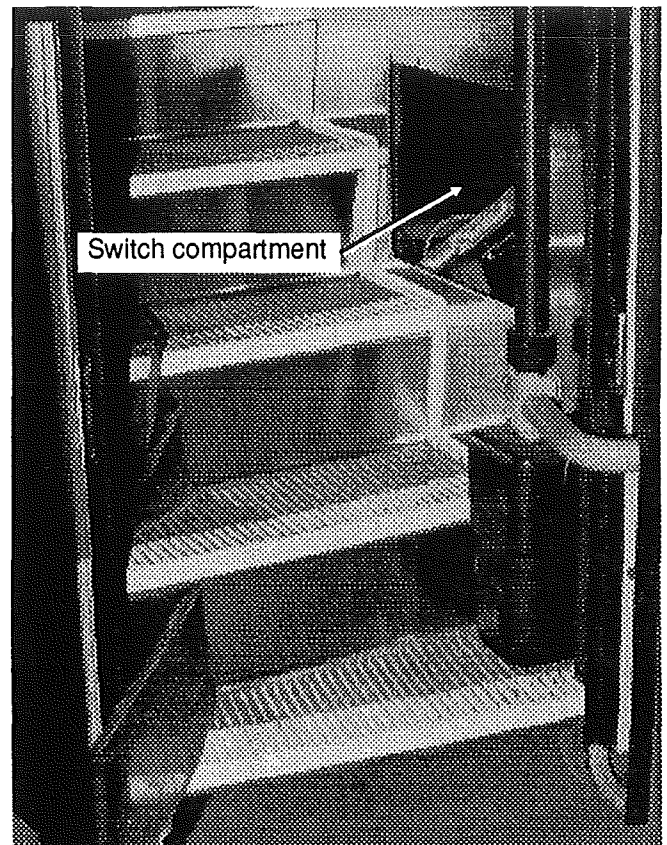

FIG. 6

OPFIG13.IMG

## Maintenance

Instructions for proper use of the camera are included in the "Operating instructions" manual provided in the technical publication box delivered with the vehicle. The adjustments or repairs of the camera should only be done by qualified video service personnel. Remove the camera from its location as follows:

1. Set battery main disconnect switches to the "ON" position.

**WARNING: Set the remote control switch in engine compartment to the "OFF" position to prevent accidental move of the vehicle by another person.**

2. Remove the three (3) screws retaining the switch compartment panel which is located on the R.H. side of rear section stepwell (see fig. 6). Remove panel, then set switch to the "ON" position to extend the back-up camera.

3. Working from outside of vehicle, remove the cotter pin from the clevis pin of the camera air cylinder extension rod.

4. Open and block the camera hinged panel to its maximum position.

5. Using a seven (7) mm wrench, remove the four (4) bolts securing the camera hinged panel to the rear cap, while retaining panel to prevent it from falling off vehicle. Carefully lower the camera hinged panel to disconnect the coaxial cable and wire connectors from rear cap.

6. Lay the camera hinged panel assembly on a clean work bench.

7. Remove the four (4) bolts retaining the camera mounting plate to its enclosure (see fig. 7).

8. Remove the two (2) center bolts to separate camera from its mounting plate.

9. Disconnect coaxial cable from camera, then disconnect wires from camera and thermal switch.

10. Send the camera to a qualified video service center.

Reverse the above procedure to reinstall the camera.

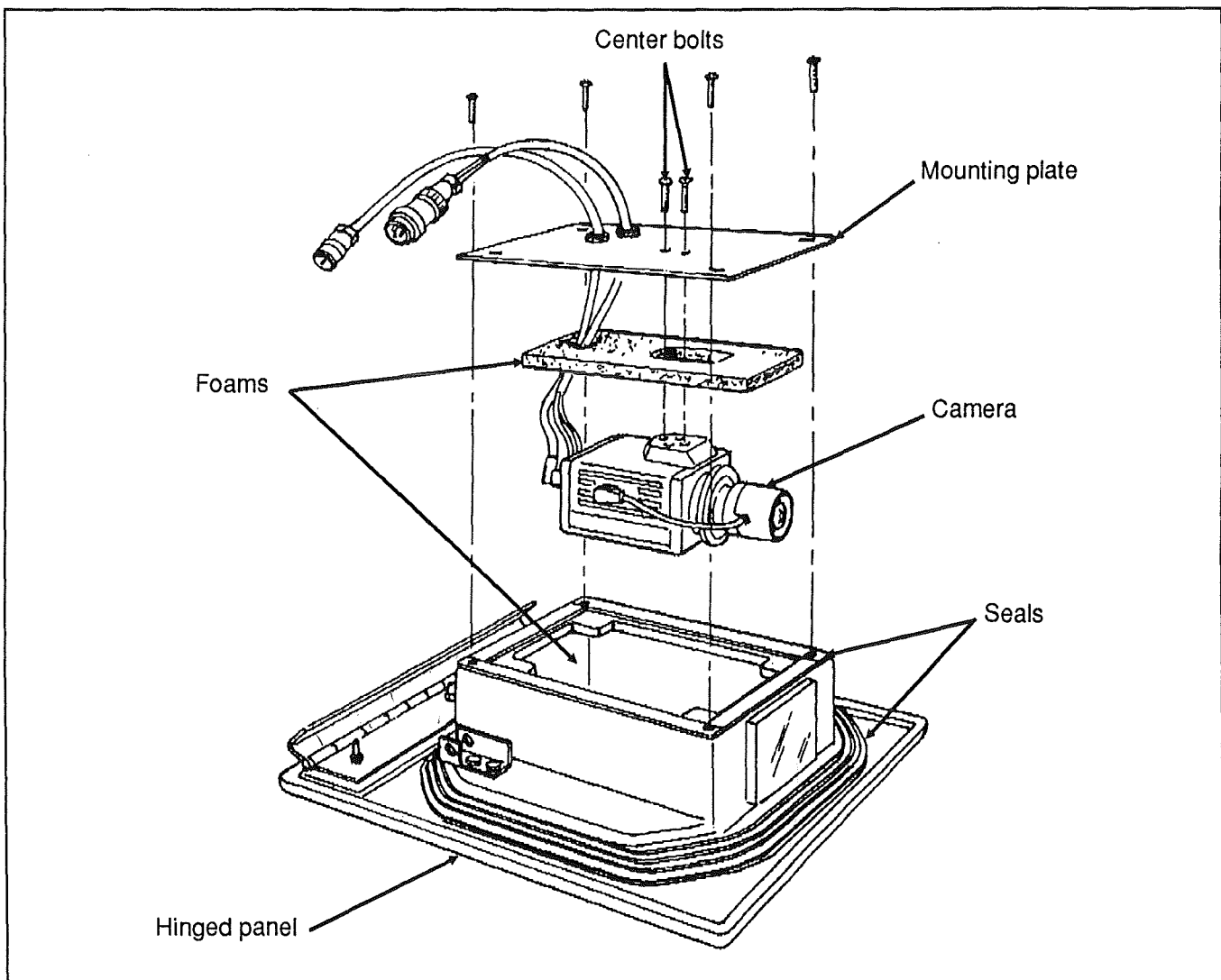

FIG. 7 - Back-up camera disassembly

MA5-1807.IMG

## MONITOR

### General description

A monitor is installed on the R.H. dashboard control panel; brightness and contrast controls located over the monitor enable the adjustment of the monitor as required. The monitor is fed by a 5 volt current, and is connected to a 12-5 volt transformer in the "Alarm junction box". For specific wiring information, refer to diagram # 22/24 of the master wiring diagrams.

### Maintenance

Repair of the monitor should only be done by a qualified service center. Remove the monitor from its location as follows:

1. Set battery main disconnect switches to the "OFF" position.
2. From driver's compartment, remove both snap caps and retaining screws, one on each side of dash cover, then remove the dash cover.
3. Disconnect the black connector from the top of monitor (see fig. 8).
4. Disconnect the 6 pin connector located behind the monitor.
5. Remove both screws on top of monitor bracket, then remove both screws, one on each side of monitor (see fig. 8).
6. Remove carefully the monitor from its location.

Reverse the above procedure to reinstall the monitor.

## TACHOGRAPH

### General description

The multi-purpose tachograph, which is available as optional equipment, includes the following items:

#### Speedometer

Indicates driving speed in m.p.h. or km/h.

#### Odometer

Indicates the accumulated vehicle distance.

#### Tachometer

Indicates engine speed in hundreds of revolutions per minute (rpm).

#### Clock

Operates even if the battery main disconnect switches are set to the "OFF" position.

#### Central joint indicator light

Lights when pressure is applied on the central joint to improve roadability of articulated coach.

#### Paper recording

The paper recording of speedometer and tachometer is available in a 24 hour or seven day period format.

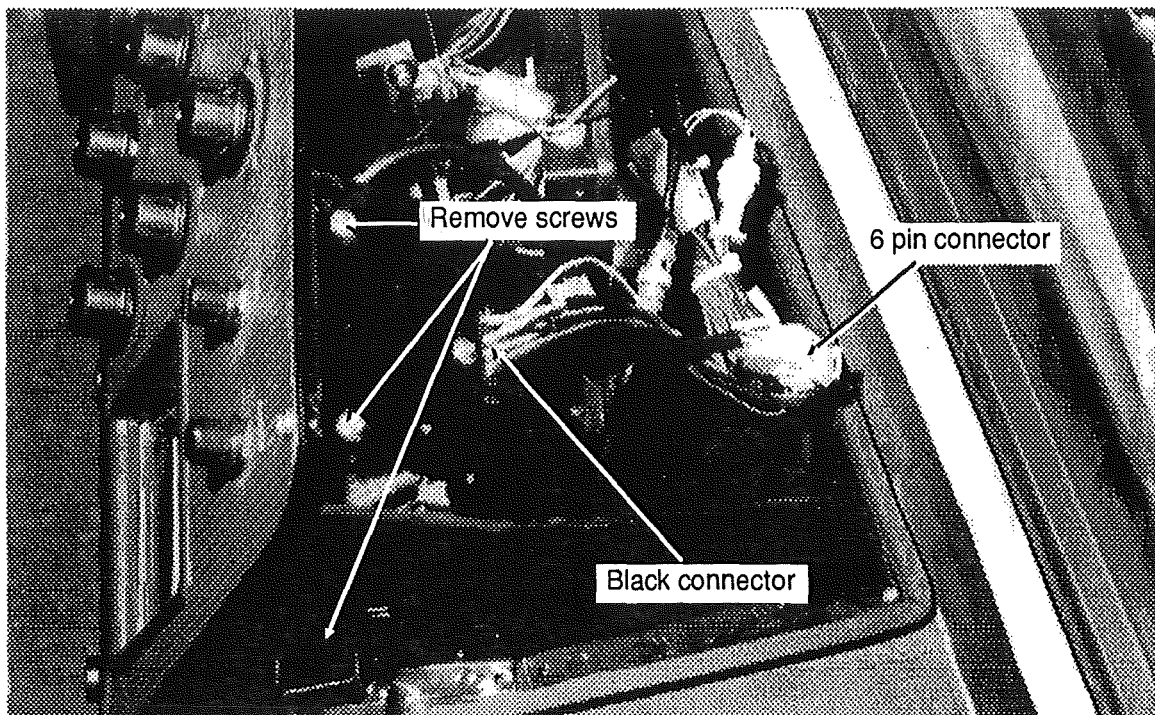

FIG. 8

MA5-1808.IMG



## Maintenance

To change card inside tachograph, open the tachograph cover using the key provided; lift the card retaining tab, and replace card with the m.p.h. or km/h side facing the tab. Then replace retaining tab and close cover.

**CAUTION:** Do not run engine without card or with damaged card in tachograph as it may damage tachograph mechanism. Install a plastic card (Prévost #59-0251) when vehicle has to be operated without a regular tachograph card.

To reset the clock, open the tachograph cover using the key provided, and turn the adjustment roller on L.H. side of tachograph.

To repair or troubleshoot the tachograph, refer to the "Service manual" annexed to this section.

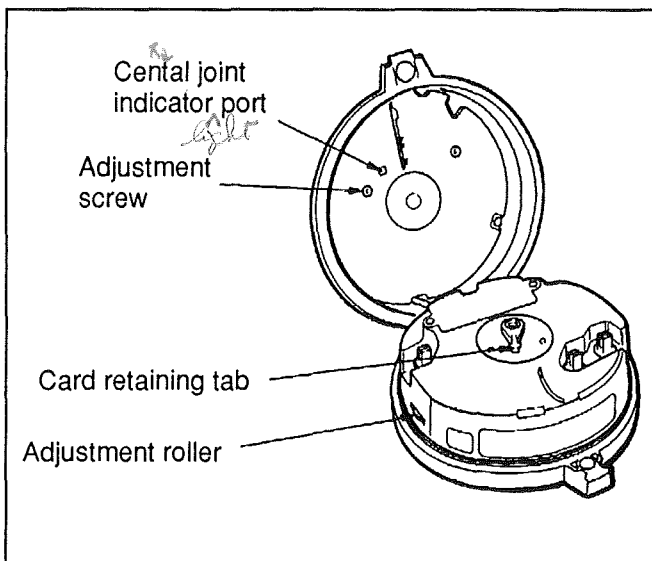

FIG. 9 - Tachograph

OPH5609.PCX

## COMFORT LEVEL INDICATOR

### Description

A comfort level indicating device is mounted on the lavatory outer wall beside the waste paper container. The purpose of this device is to advise the driver by an audible alarm when rear roadhandling or road conditions cause poor comfort level to the rear section passengers. In this case, the driver is invited to reduce speed. For specific wiring information, refer to diagram # 21/24 of the master wiring diagrams under heading "Articulation switch".

**NOTE:** The comfort level indicating device is fed by a signal from the "speed switch" which is activated at speeds of 40 m.p.h. (65 km/h) and over.

## Adjustment

Adjust the sensitivity of the comfort level indicating device as follows:

1. At last L. H. row of seats in rear section, remove wing nut under window seat cushion, then remove cushion.
2. Locate the comfort level indicator cover, remove the four (4) Phillips head screws and washers retaining cover to the lavatory wall, then remove cover.
3. Unscrew the adjusting screw (see fig. 10), raise the weight to decrease the sensitivity, or lower the weight to increase the sensitivity of the comfort level indicator, then tighten the weight rod with the adjusting screw.
4. Install the comfort level indicator cover, then secure with the four (4) Phillips head screws and washers.
5. Install the window seat cushion, then secure with the wing nut.

## Removal and installation

1. Repeat steps 1 and 2 above.
2. Remove cable tie, remove retaining clip screw, then disconnect wiring connector C-171.
3. Remove the four (4) screws retaining the comfort level indicator mounting plate to the lavatory wall.
4. Reverse the above procedure to reinstall the comfort level indicator.

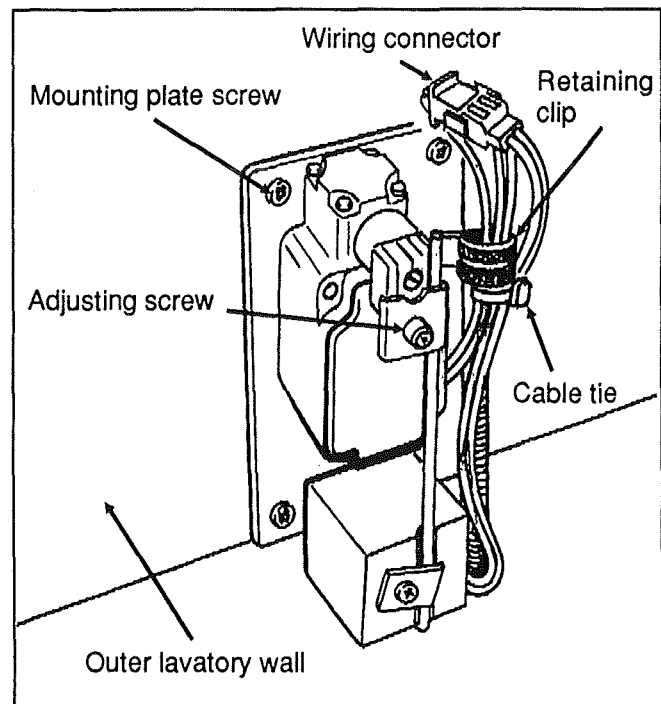

FIG. 10 - Comfort level Indicator

MA5-1810.IMG

## COLD STARTING AID (ETHER)

The vehicle is equipped with an ether cold starting aid designed to ease engine starting when temperature is below 35 °F (2 °C). A manually-operated type is installed as standard equipment, while an electrically-operated type is available as optional equipment.

### Manually-operated type

On vehicles equipped with a manually-operated cold starting aid, the system consists of a starting fluid cup located on top of the air intake duct. To use cold weather starting fluid, raise the cover of the starting fluid cup and force one 7 cc capsule down over pointed tube in cup and squeeze until all fluid enters cup. Remove capsule, shut cover tightly, and then start engine from engine compartment.

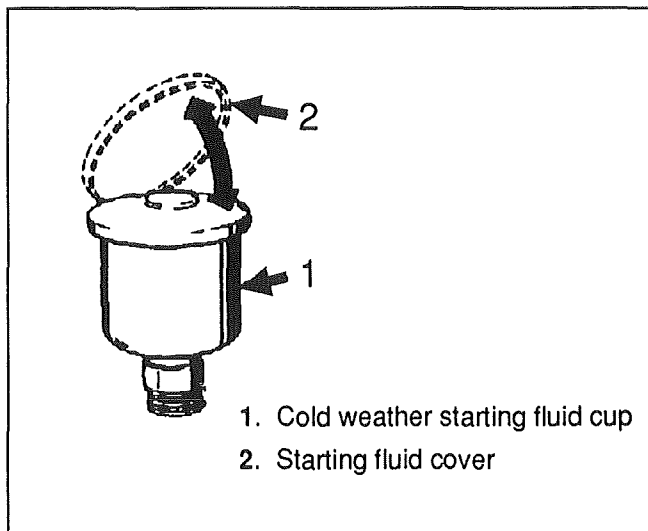

FIG. 11

OPH56030.PCX

**CAUTION:** This practice should be performed only when absolutely necessary. If required, we recommend that the starting fluid be used only in 7 cc capsule form, one at a time. Excessive use of fluid could result in serious engine damage.

**WARNING: FIRE HAZARD -** Starting fluid used in the capsules is highly flammable, poisonous and anesthetic. Do not smoke while using or handling capsules, and keep away from flame or high temperatures. Avoid inhaling fumes produced by starting fluid.

### Electrically-operated type

On vehicles equipped with an electrically-operated cold starting aid, the system consists of the main following parts:

- Ether starting aid switch
- Ether cylinder
- Solenoid valve (24 V)
- Thermal cutout valve
- Atomizer

The ether starting aid switch is located near the ignition switch on the L.H. lower control panel. To activate the ether starting aid, proceed as follows:

1. Prior to cranking engine, press switch three (3) seconds to fill solenoid valve.
2. Release switch to discharge shot.
3. Allow three (3) seconds for shot to discharge.
4. Start engine, use additional shots if necessary to keep engine running.

**CAUTION:** This practice should be performed only when absolutely necessary. Excessive use of fluid could result in serious engine damage.

The ether cylinder and solenoid valve assembly are mounted on the condenser hinged door and accessible from the refrigerant dryer compartment door (see fig. 12).

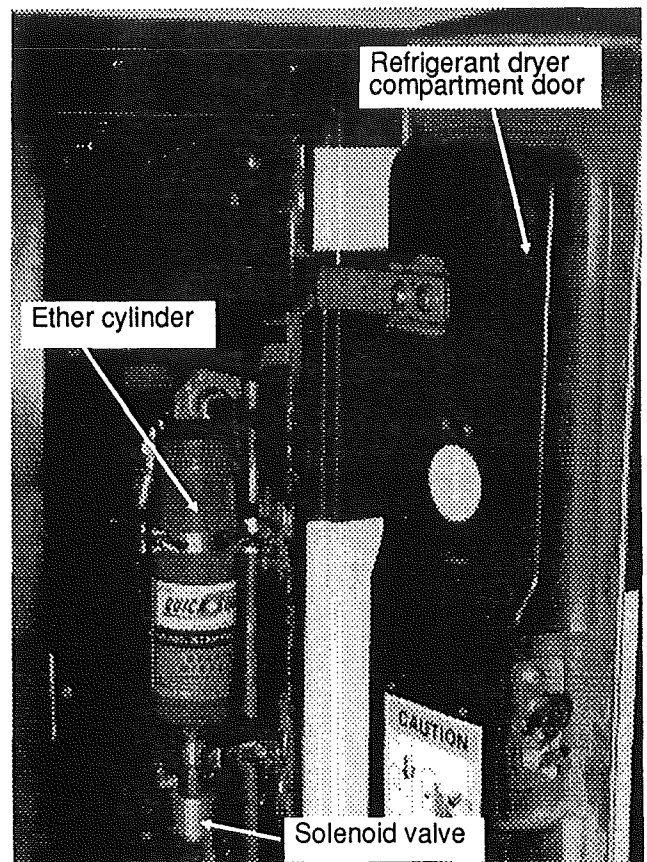

FIG. 12

MA5-1612.IMG

The thermal cutout valve is mounted on the engine R.H. side thermostat housing, and the atomizer is installed on top of air intake duct (refer to fig. 13).

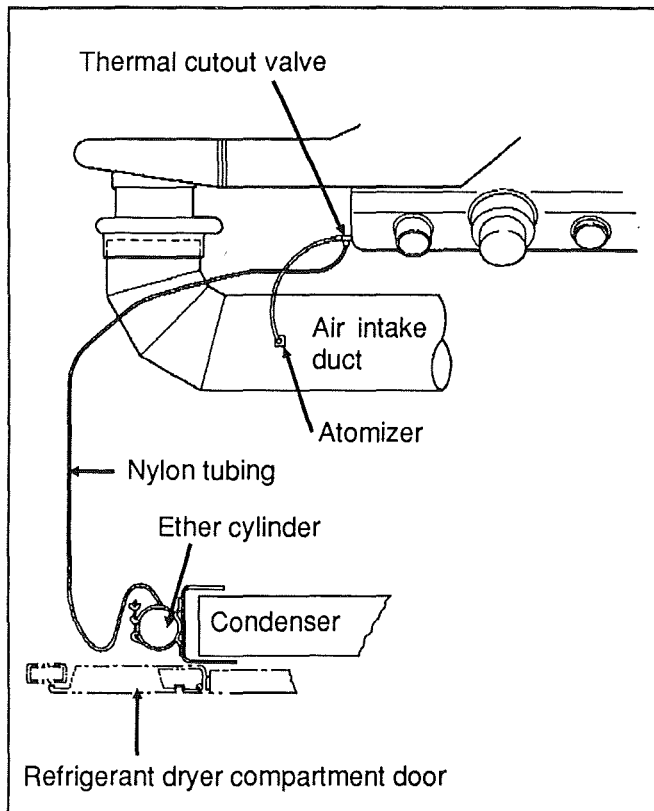

FIG. 13 - Electric cold starting aid installation

### Preventive maintenance

During the summer months, remove cylinder to avoid high temperature actuation of the cylinder safety relief device. Always screw valve cap into valve opening to prevent entrance of road dirt. When removing cylinder, always be careful to prevent dirt from entering the valve.

### Troubleshooting (if system is non-functioning)

**WARNING:** During the following test, direct free end of tube away from personnel and all sources of ignition as this fuel is extremely flammable. Avoid breathing vapors and contacting fuel with skin. Never smoke during test.

1. Check cylinder for hand tightness and fuel supply. (Empty cylinder weight is approximately 17 oz (480 g); full cylinder weight is approximately 35 oz (990 g). If cylinder is empty, replace it. Before replacing cylinder, install new valve gasket in solenoid valve.
2. If still not functioning, disconnect tubing at solenoid valve fitting. Actuate solenoid valve. (Ask an assistant to actuate solenoid valve by means of the switch on the dashboard.)

- If solenoid valve is non-functioning, check electric circuit, (refer to diagram # 21/24 of the master wiring diagrams); if sound, remove and replace the solenoid valve; if not, repair electric circuit.

- If valve is functioning, reassemble valve fitting and connect tube. Disconnect tube at thermal cutout valve from port "Tube from valve".

3. Actuate the solenoid valve.

- If fuel is not discharged from tube, remove tube and blow out or replace.

- If fuel is discharged, connect tube to thermal cutout valve, then disconnect other tube.

4. Actuate the solenoid valve.

- If fuel is not discharged, replace the cutout valve.

**NOTE:** If engine coolant temperature is 90 °F (32 °C) or over, it is normal that fuel is not discharged as the valve is in closed position.

- If fuel is discharged, connect tube to thermal cutout valve, then disconnect tube to atomizer.

5. Actuate the solenoid valve.

- If fuel is not discharged from tube, fuel line is clogged. Remove tube and blow out or replace.

- If fuel is discharged, replace the atomizer.

### Thermal cutout valve quick test

1. Engine coolant temperature must be below 90 °F (32 °C).

2. Temporarily, disconnect tube at thermal cutout valve from port "Tube to atomizer".

3. Actuate solenoid valve. (Ask an assistant to actuate solenoid valve by means of the switch on the dashboard.) Ether should be discharged through the thermal cutout valve.

**WARNING:** Avoid breathing vapors and contacting fuel with skin. Never smoke during test.

4. Reconnect tube to thermal cutout valve.

5. Start engine, using cold starting aid if necessary, then stop engine when it reaches operating temperature.

6. Disconnect tube at thermal cutout valve as in step 2, then repeat step 3. No ether should be discharged.

## DESTINATION SIGN

### Description

The destination sign, located at front of the vehicle at top of the upper windshield, is lighted and electrically controlled. The sign is activated by means of a rocker switch located on the L.H. side underneath destination sign (fig. 14).

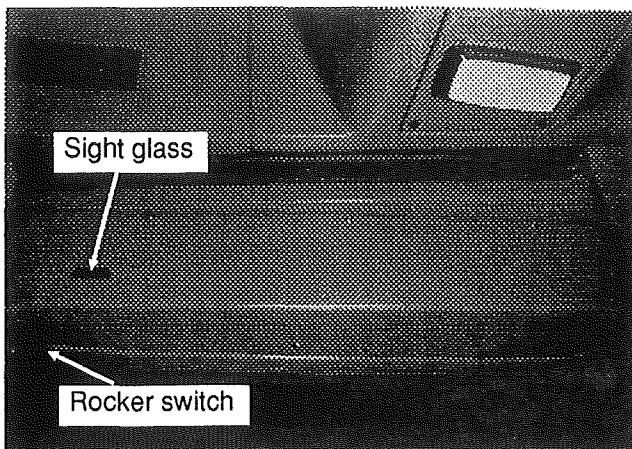

FIG. 14 - Destination sign

### Maintenance

Inspect regularly the following items:

1. Check for free and easy mechanism movement.
2. Check for loose item on the sign mechanism, such as wire, loose clips, hanging tape, etc.
3. Check tension and condition of the two drive belts; replace as required.
4. Periodic lubrication is not recommended.

### Fluorescent replacement

1. Remove the six (6) Phillips screws and washers retaining the destination sign cover, then carefully remove the cover from its location.
2. Remove both Phillips screws, one on each fluorescent assembly hinged bracket (see fig. 15), then lower assembly.
3. Push on tab located on each fluorescent pin receptacle while removing fluorescent.
4. Install new fluorescent, then reinstall the assembly by reversing the above procedure.

### Electric motor removal and installation

To remove the electric motor, repeat step 1 above, plus the following:

1. Disconnect both wires from electrical motor.
2. Remove both screws retaining motor to destination sign frame (see fig. 15).
3. Slide motor upwards, then remove the drive belt.
4. Remove motor through the provided opening.
5. Install the motor by reversing the above procedure.

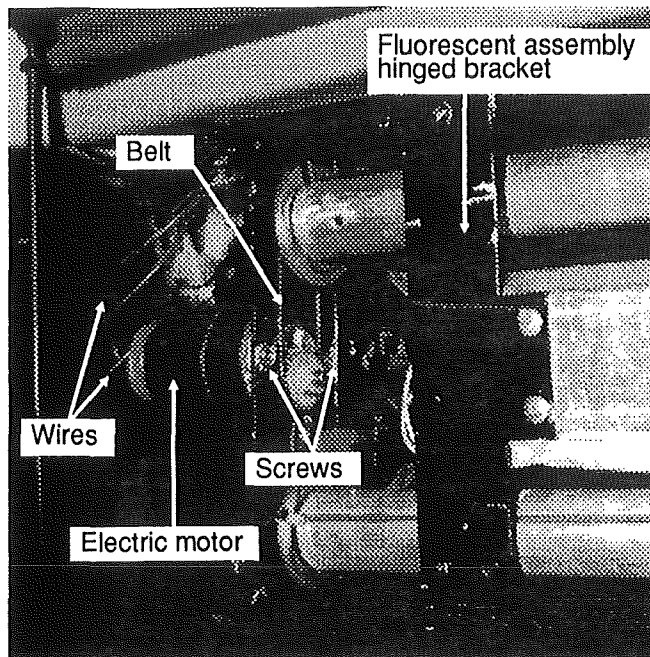

FIG. 15 - Electric motor

### Sign curtain repair

In the event a destination sign curtain is torn, it can be repaired with 3M polyester tape or any equivalent cellophane tape. When repairing a tear, the tape should be used on both sides of the curtain.

## LAVATORY

### Description

The lavatory is located at left rear corner of rear section, two (2) steps down from passenger's level. The lavatory consists of a stainless steel floor provided with antislip thread and stainless steel bright finish paneling on the lower half of the walls and sink partition. The upper half section of the lavatory is made of a single fiberglass panel. A large safety mirror is mounted above the wash bassin. Extreme care has been taken in the design of the washroom to eliminate corners where dirt may collect. The use of stainless steel enables an easy maintenance of the lavatory at all times.

**NOTE: A soap dispenser may have been installed as optional equipment.**

### Maintenance

The regular servicing procedure for the lavatory is described in the "Operator's Manual" under heading "Servicing the lavatory", included in the technical publication box delivered with the vehicle.

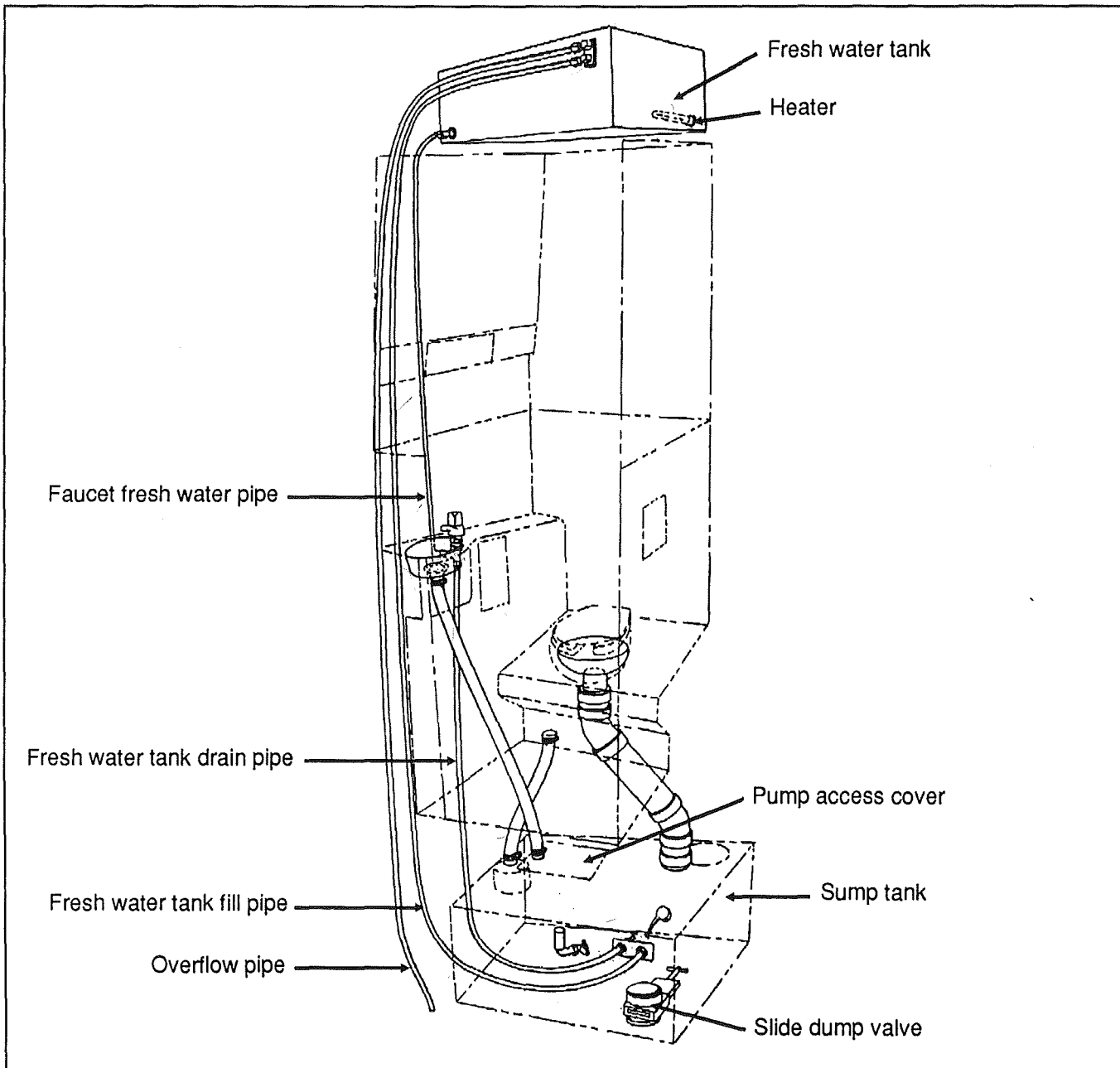
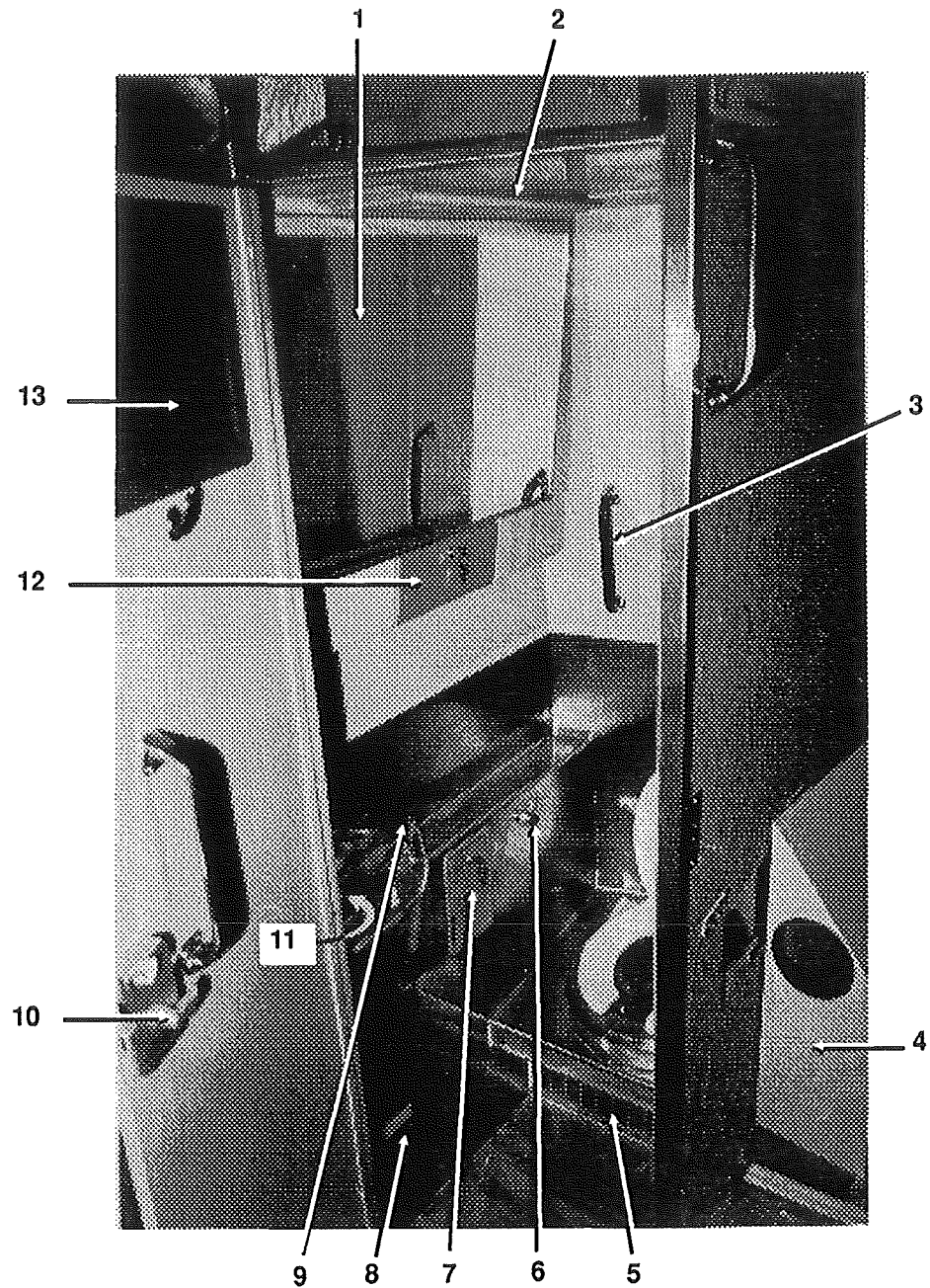

FIG. 16 - Lavatory Installation

MA5-1816.JPG



- |                            |                                |
|----------------------------|--------------------------------|
| 1. Mirror                  | 8. Night light                 |
| 2. Fluorescent assembly    | 9. Fresh water faucet          |
| 3. Grip handle             | 10. Door lock                  |
| 4. Waste container         | 11. Emergency call push button |
| 5. Exhaust air grille      | 12. Towel dispenser            |
| 6. Flush push button       | 13. Lavatory door grille       |
| 7. Toilet tissue dispenser |                                |

FIG. 17 - Lavatory

MA5-1817.IMG

## Emergency buzzer

The lavatory emergency buzzer is mounted on the alarm junction box in front service compartment, and sounds when the emergency call push button switch in the lavatory compartment is activated. For specific wiring information, refer to diagram #16/24 of the master wiring diagrams. To remove the emergency call push button switch, proceed as follows:

1. From outside the lavatory, remove the nine (9) snap caps and retaining screws from the outer lavatory wall located beside the lavatory door (see fig. 18), then remove the wall in order to gain access to the switch electric connections.
2. Disconnect wires from switch.
3. From inside the lavatory, remove the two (2) Phillips head screws retaining the emergency call switch to the lavatory inner wall, then remove the switch from outside the lavatory.

Reverse the above procedure to install the switch.

## Occupied signs

Closing and locking the lavatory door from inside will illuminate outside signs which are mounted on the rear wall of vehicle, over the windshield, and also the lavatory indicator light on the L.H. side dashboard control panel. To check circuit continuity, refer to diagram #16/24 of the master wiring diagrams.

## Door lock

Lavatory door lock has inside and outside handles, as well as an inside latch to lock door from inside the compartment. If the lock fails to release, the door can be opened from the outside with a special key which is supplied to the driver.

Lock assembly can be removed from the door, then readily disassembled and parts replaced, if necessary (see fig. 19). A thin coat of lubricant on all moving parts will ensure trouble-free operation.

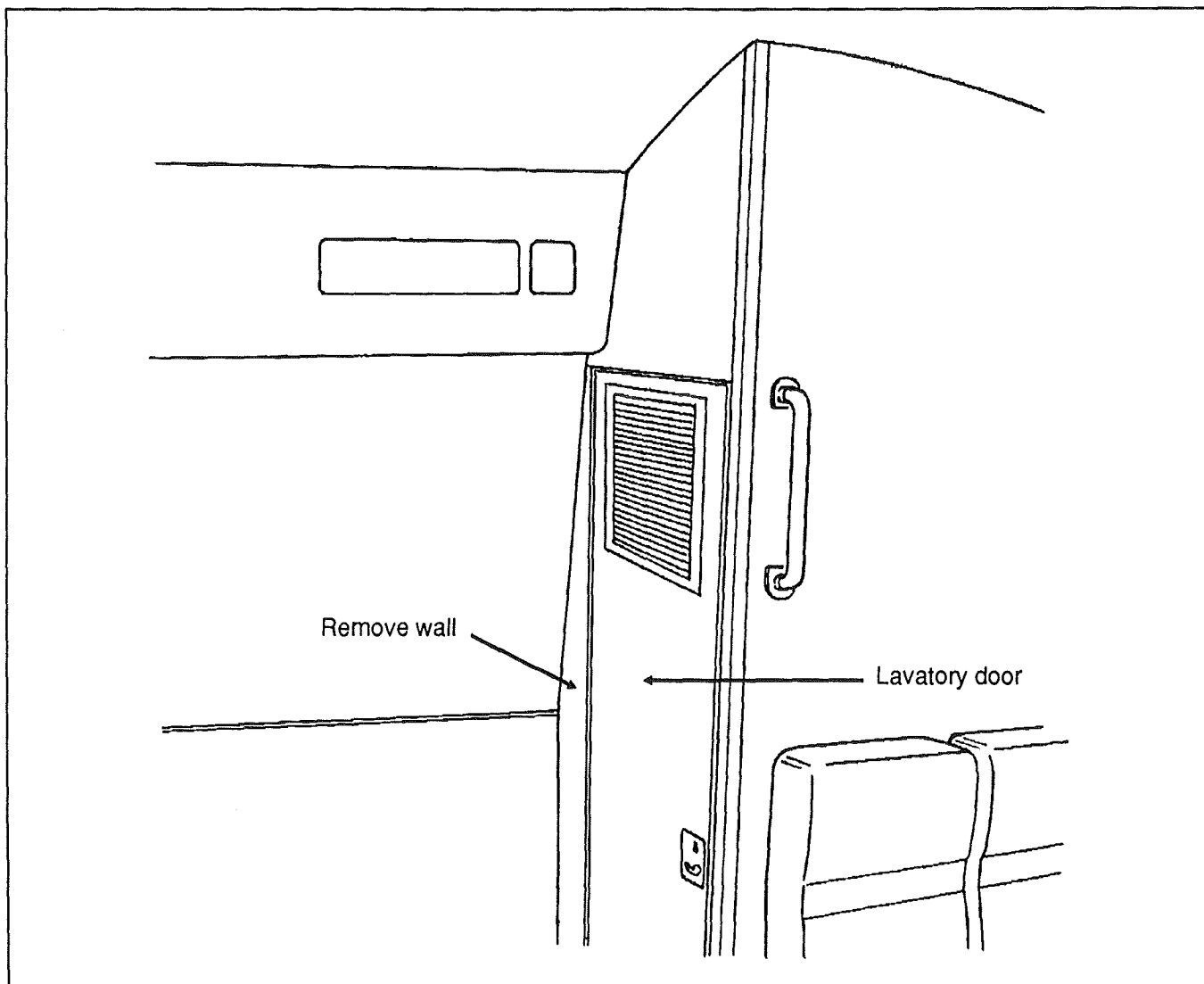

FIG. 18

MA5-1818.JPG

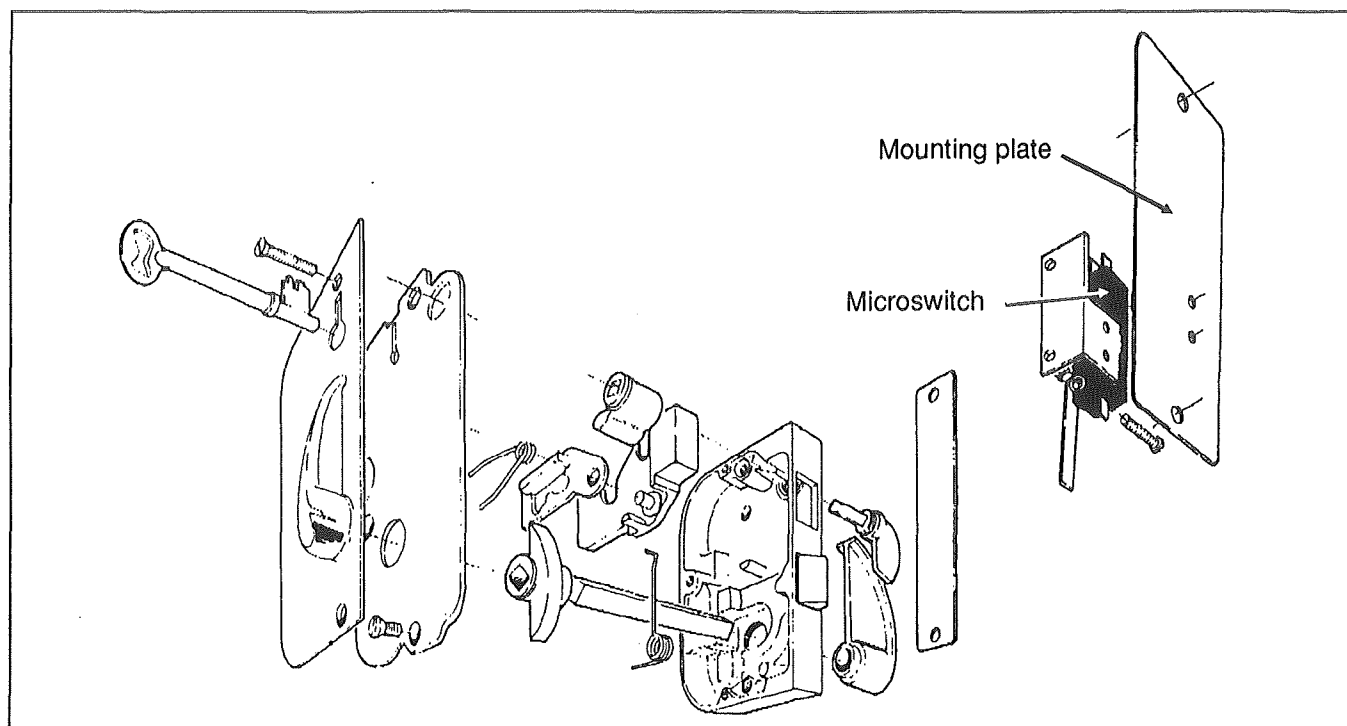

FIG. 19 - Lavatory door lock disassembly

MA5-1819.IMG

## Lavatory light

The lavatory light is installed on ceiling and is provided with two fluorescents. A microswitch, which is mounted in the door frame, is activated by the door lock mechanism upon locking to energize the lamp as well as the "lavatory occupied" signs in vehicle. This switch is readily serviced by removing the two Phillips head screws securing the mounting plate to the outer lavatory wall.

Proceed as follows to replace a fluorescent:

1. Press in side of lens opposite of mirror, free lens from its retaining groove, slide out other side, then lower and remove lens.
2. Unsnap defective fluorescent tube by pushing its both extremities simultaneously against felt discs (see fig. 20).
3. Holding the fluorescent with one hand, push inwards one of the pin receptacle steel plates to free tube extremity, then remove tube from its fixture.
4. Reverse above procedure to install new fluorescent tube.

If ballast is defective or a wire feed voltage check is required, ballast cover may be removed by performing the first three steps and the following:

**WARNING: Be careful when checking the ballast feed voltage as its output voltage is 600 volts.**

- a. Grasp and press inwards both cover extremities to free its edges from the four rivets.
- b. Reverse previous steps to install cover, fluorescent tubes and lens.

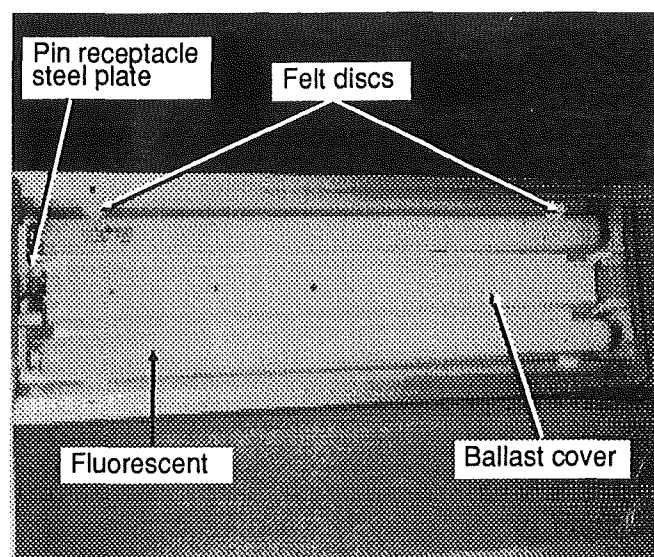

FIG. 20 - Lavatory fluorescent lamp assembly

MA5-1820.IMG

## Lavatory night light

The lavatory night light is illuminated as soon as the ignition switch is set to the "ON" position. Proceed as follows to replace defective bulb:

1. Unscrew the two (2) Phillips head screws retaining the lens to the lavatory wall, then remove it.
2. Push and turn the bulb counterclockwise, then pull it out of the socket.
3. Place the new bulb into the socket, then push and turn clockwise to lock in position.
4. Place the light lens and fix in place.



## Flush push button

The flush push button (red) is located near the toilet tissue dispenser. Press on push button to actuate a pneumatic timer located on the other side of wall; this timer allows an electric current flow during a preset time to a pump in the sump tank.

## Pneumatic timer removal and installation

1. Unscrew and remove the flush push button lock nut (see fig. 21).
2. Using the appropriate key, unlock and open the toilet tissue dispenser flap.
3. Remove all toilet tissues.
4. Unscrew the three (3) Phillips head screws retaining the toilet tissue dispenser assembly, then remove it from its location.
5. Remove pneumatic timer through this opening, taking care to disconnect electric wires.

**NOTE: Care must be taken to avoid losing the spacers installed on the mounting sleeve.**

6. Reverse the above procedure to reinstall timer. The recommended torque for the lock nut is 15 lbs.ft (21 N.m).

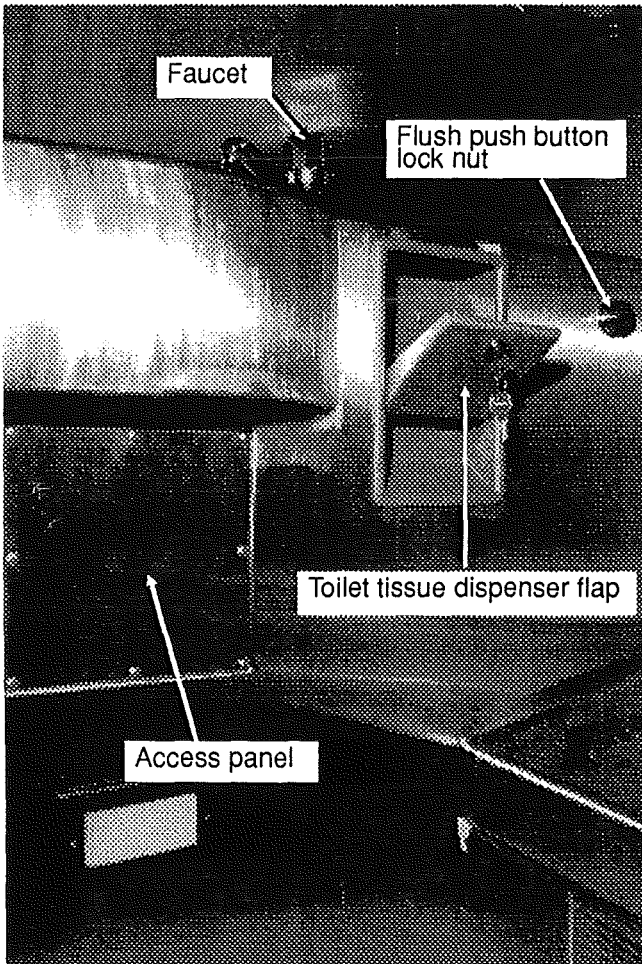

FIG. 21

## Timer adjustment

Timer may be adjusted from 0.2 second to 3 minutes by turning the time adjustment screw clockwise to increase time, and counterclockwise to decrease time. To gain access to the time adjustment screw, repeat previous steps 2, 3, and 4.

**NOTE: Washbasin and faucet plumbing is accessible by removing the access panel located under the wash basin (refer to fig. 21).**

## Fresh water tank

The fresh water tank located over the lavatory ceiling, supplies water to the wash basin by gravity. Two pipes are connected to the upper right corner of tank. The top overflow pipe runs along the rear wall to the underside of vehicle near rear bumper, while other pipe is connected to the fresh water fill valve which is installed under the sump tank. A third pipe located in the lower left corner is connected to the faucet. To gain access to the fresh water tank plumbing, remove the four (4) snap caps and screws securing the occupied sign panel to the rear wall, then remove panel. The panel located over the lavatory door can now be removed after removing the snap caps and screws retaining it to the fresh water tank framing.

## Fresh water tank heater

A water heater may have been installed as optional equipment. The heater as well as its connector (C-182) is accessible for a quick electrical check by the access panel located over the toilet. For specific wiring information, refer to diagram #23/24 of the master wiring diagrams.

## Ventilation fan and motor

### Description

The lavatory ventilation fan, mounted over the spare tire compartment in the rear section of vehicle, serves two purposes. It exhausts objectionable odors and provides a constant air circulation in the lavatory compartment by heating or cooling the lavatory with the vehicle ambient air. Air enters the lavatory compartment through a vent grille located over the lavatory door.

**NOTE:** This exhaust fan runs constantly whenever the ignition switch on the L.H. lower control panel is in the "ON" position.

### Maintenance

The frequency of preventive maintenance should be determined according to vehicle mileage and operating conditions. However, it is recommended to check this item approximately every 50,000 miles (80 000 km).

Remove fan and motor assembly. Free operation of fan housing wheel and motor is important. Check fan housing wheel and exhaust duct. If dirty, they should be cleaned. When defective motor occurs, new motor must be installed.

**NOTE:** This motor is similar to the driver's heater unit and the upper windshield defroster.

### Removal and installation.

1. Open the lavatory service compartment door, then remove the flexible drain hose container by unscrewing the two (2) hose clamps. This step is necessary to have access to the ventilator fan and motor assembly. Refer to figure 22 for details.

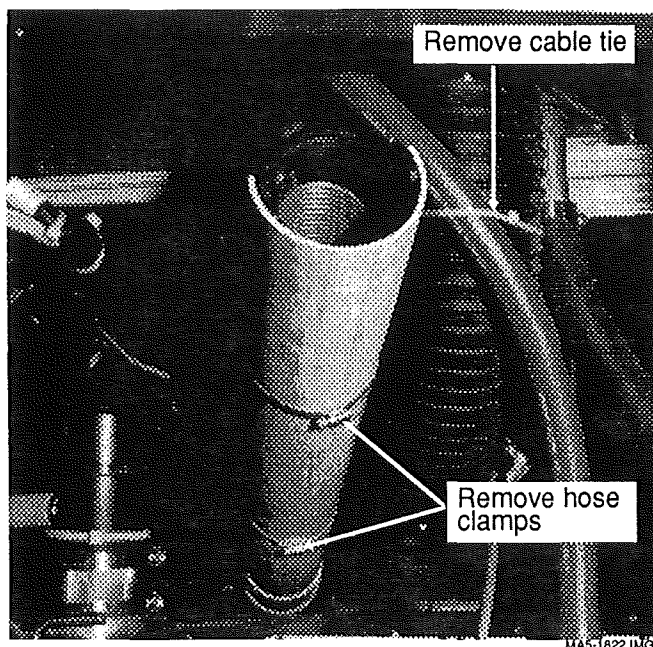

FIG. 22 - Lavatory service compartment

2. Remove the cable tie retaining the fresh water return hose (red) to the ventilator inlet duct. Then, remove the hose clamp retaining duct to the ventilator inlet.
3. Pull up the inlet duct, remove the outlet duct hose clamp, then remove the ventilator outlet duct from the ventilator housing.
4. Unscrew the ventilator support retaining bolts, disconnect the ventilator motor connector, and remove motor with fan assembly (see fig. 23).

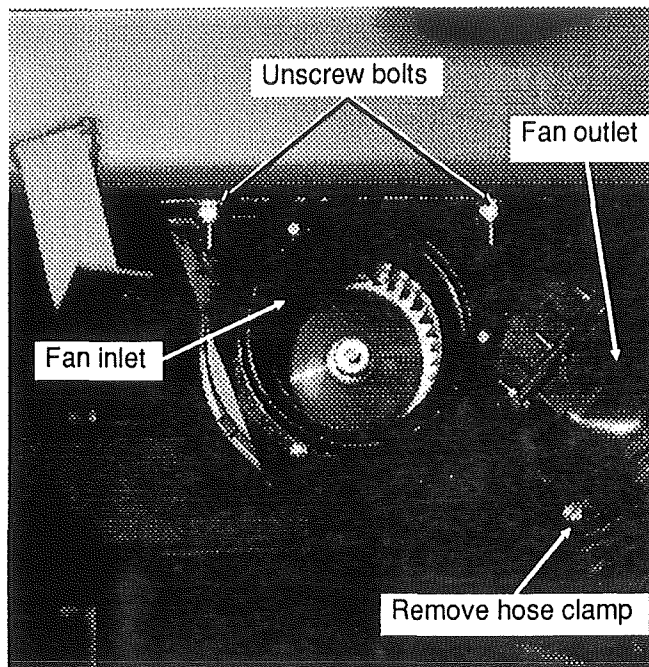

FIG. 23 - Lavatory ventilation fan and motor installation

5. Place the assembly on a plane surface, separate the motor from the housing and fan.
6. Remove the gasket at the outlet of housing assembly.
7. Separate the housing by removing the six (6) retaining clips.

**NOTE:** Remember location to ease reassembly procedure.

8. Unscrew the "Allen" screw retaining the fan wheel on the shaft and the three (3) retaining bolts of motor, then separate the motor from the housing. Refer to figure 24 for details.

9. Reverse previous steps to reinstall motor, then motor and housing assembly on vehicle.

**NOTE:** If cable ties have been removed to ease disassembly, remember to replace new ones afterwards.

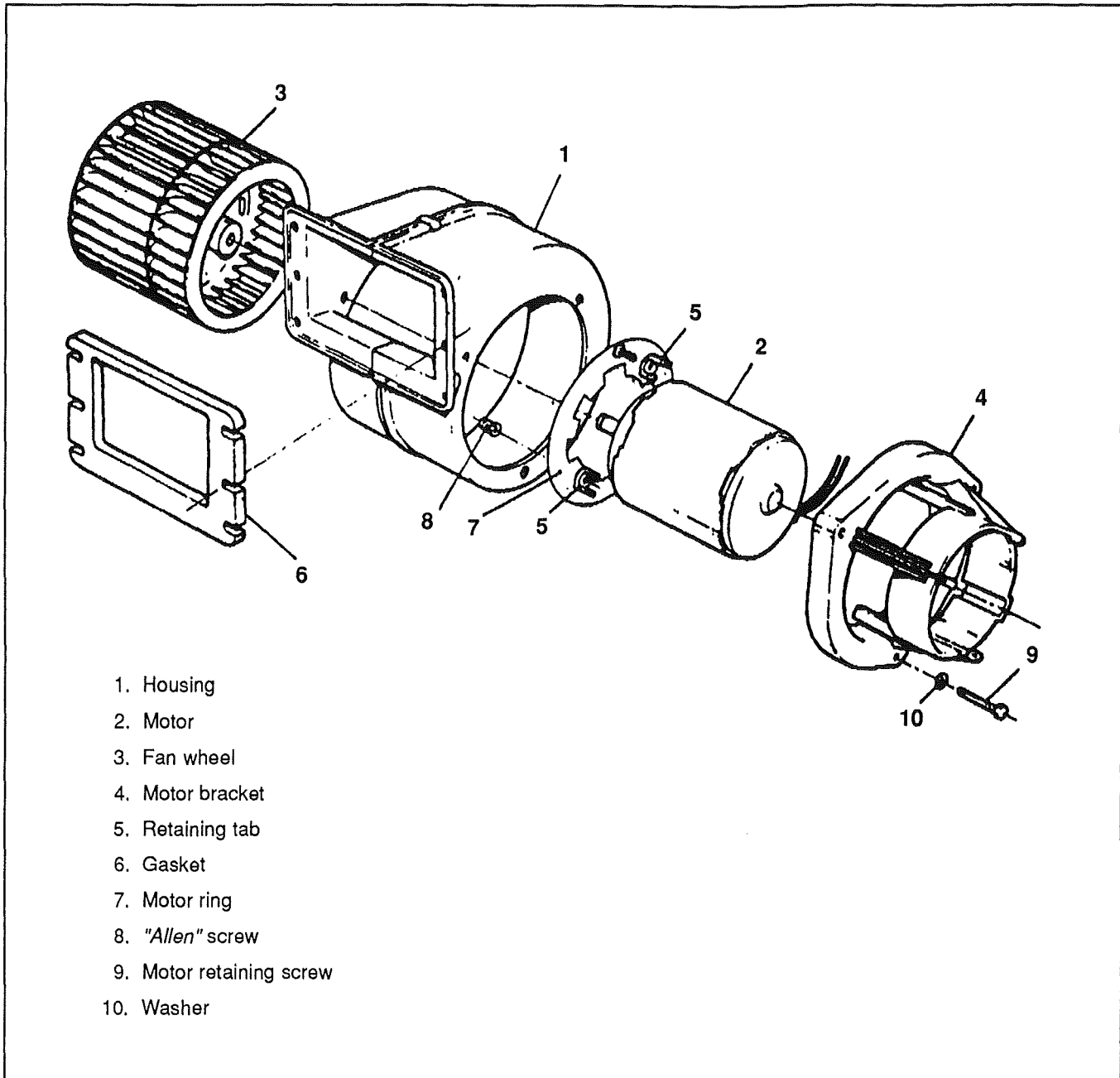

FIG. 24 - Lavatory ventilation fan and motor disassembly

MA5-1824.JPG

## SPECIFICATIONS

### HUBODOMETER (U.S. model: m.p.h.)

Make . . . . . Stemco  
 Supplier number . . . . . 650-0019  
 Prévost number . . . . . 65-0002

### HUBODOMETER (Canada model: km/h)

Make . . . . . Stemco  
 Supplier number . . . . . 650-0025  
 Prévost number . . . . . 65-0117

### SPEAKERS

Make . . . . . Blaupunkt  
 Model . . . . . DL 1230  
 Max. rating . . . . . 30 Watts  
 Resistance . . . . . 4 ohms  
 Prévost number . . . . . 90-0502

### TACHOGRAPH (U.S. model)

Make . . . . . VDO  
 Scale . . . . . 0 - 80 m.p.h.  
 . . . . . 0 - 3300 rpm  
 . . . . . 24 hours  
 Prévost number . . . . . 59-0240  
 Paper chart (Prévost number) . . . . . 59-0122  
 Plastic card (Prévost number) . . . . . 59-0251

### TACHOGRAPH (Canada model)

Make . . . . . VDO  
 Scale . . . . . 0 - 125 km/h  
 . . . . . 0 - 3300 rpm  
 . . . . . 24 hours  
 Prévost number . . . . . 59-0239  
 Paper chart (Prévost number) . . . . . 59-0179  
 Plastic card (Prévost number) . . . . . 59-0251

### ETHER START CYLINDER

Make . . . . . Quick start  
 Volume net . . . . . 22 U.S. fl. oz  
 Supplier number . . . . . LP-535  
 Prévost number . . . . . 51-0173

**DESTINATION SIGN FLUORESCENT TUBE**

Model . . . . . F30T8 CW4  
Length . . . . . .30" (76 cm)  
Wattage . . . . . 20  
Quantity . . . . . 1  
Prévost number . . . . . 83-0120

**EMERGENCY BUZZER**

Make . . . . . Mallory  
Frequency . . . . . 2900  
Supplier number . . . . . SC 628 W  
Prévost number . . . . . 56-1957

**LAVATORY FLUORESCENT TUBES**

Model . . . . . F15T8 CW  
Length . . . . . .18" (45 cm)  
Wattage . . . . . 15  
Quantity . . . . . 2  
Prévost number . . . . . 83-0102

**PNEUMATIC TIMER**

Make . . . . . Furnas  
Type . . . . . Resettable  
Time . . . . . .0,2 to 180,0 seconds  
Supplier number . . . . . 55-AA  
Prévost number . . . . . 90-0348

**FRESH WATER TANK**

Make . . . . . Prévost  
Capacity . . . . . 24 U.S gal. (90 liters)  
Prévost number . . . . . 40-9063

**FRESH WATER TANK HEATER**

Make . . . . . Temro  
Wattage . . . . . 50  
Voltage . . . . . 115  
Supplier number . . . . . 12632  
Prévost number . . . . . 56-1968

LAVATORY VENTILATION FAN MOTOR

Make . . . . . Aurora  
Type . . . . . RG500EF  
Voltage . . . . . 24 V DC  
Rotation . . . . . Right hand  
Supplier number . . . . . 001.58.04 / 24V  
Prévost number . . . . . 56-1194

*48Nc*









# LUBRICATION CHART AND SERVICE CHECK POINTS

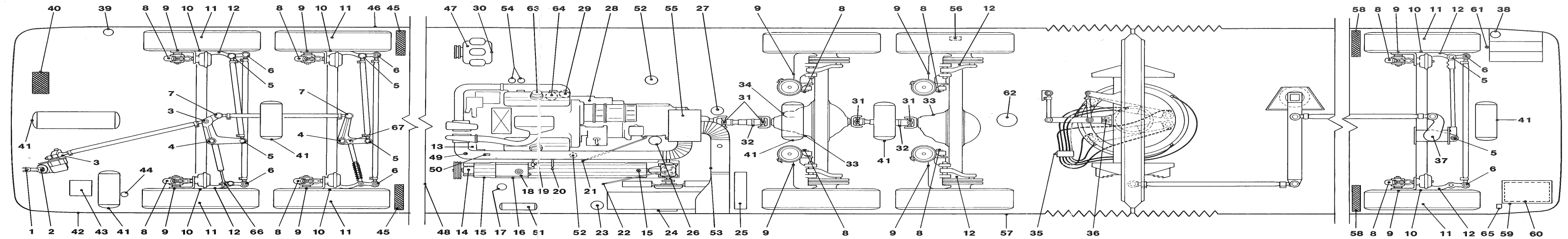

ITEM	DESCRIPTION	REMARKS	INTERVALS	LUBRICANT
1	Upper Steering Column U-Joint	One fitting	5000 miles (8 000 km)	L-5
2	Lower Steering Column U-Joint	One fitting	5000 miles (8 000 km)	L-5
3	Steering Drag Link Ends	One fitting on each end	5000 miles (8 000 km)	L-5
4	Drag Link Transfer Lever Bearings (axles 1 and 2)	One fitting per transfer lever bearing	5000 miles (8 000 km)	L-5
5	Steering Arm Ends (axles 1, 2 and 5)	One fitting on each end	5000 miles (8 000 km)	L-5
6	Tie Rod Ends (axles 1, 2 and 5)	One fitting on each end	5000 miles (8 000 km)	L-5
7	Transfer Lever Connecting Rod Ends	One fitting on each end	5000 miles (8 000 km)	L-5
8	Slack Adjusters (all wheels)	One fitting on each slack adjuster	5000 miles (8 000 km)	F-1
9	Disc Brake Power Shafts	One fitting on each power shaft	25,000 miles (40 000 km)	F-1 (see NOTE 1)
10	Steering Knuckle Pins (axles 1, 2 and 5)	Two fittings per knuckle	5000 miles (8 000 km)	L-5
11	Wheel Bearings (axles 1, 2 and 5)	Fill to mark	Daily	G-1 (see NOTE 2)
12	ABS Sensors	Apply	Only at sensor disassembly and assembly	A-2 (see NOTE 3)
13	Radiator Shutter Air Filter	Remove plug - inject 1 1/2 oz U.S. (45 ml) fluid	5000 miles (8 000 km)	F-2
14	Fan Transfer Pillow Block	One fitting on top	5000 miles (8 000 km)	L-5
15	Transfer Shaft U-Joints (both extremities)	One fitting on each end	5000 miles (8 000 km)	L-5 (see NOTE 4)
16	Transfer Shaft Slip Joint	One fitting	5000 miles (8 000 km)	L-5
17	Preheater Fuel Oil Filter	Change cartridge element	100,000 miles (160 000 km)	Fill with clean fuel oil
18	Oil Reserve Tank	Check daily	Daily	Fill with O-1
19	Starter	"Allen" plugs: 8 to 10 drops	During overhaul or 100,000 miles (160 000 km)	H-1 (see NOTE 5)
20	Check Engine Crankcase Oil Level	Keep to "FULL" mark on dipstick	Daily and change after 10,000 miles (16 000 km)	O-1
21	Check Transmission Oil Level	Keep to "FULL" mark on dipstick	Daily	O-5 (see NOTE 6)
22	Check Gearbox Oil Level	Keep to "FULL" mark on dipstick	5000 miles (8 000 km)	G-1
23	Fuel Filter/Water Separator	Drain accumulated water	When accumulated water or warning light illuminated	-----
24	Lubricate Shutter Rods and Cranks	Apply	5000 miles (8 000 km)	O-5
25	Power Steering and Condenser Fan Motor Oil Tank	Keep to "FULL" mark on dipstick	5000 miles (8 000 km)	H-2 (see NOTE 7)
26	Transmission Oil Filter	Change cartridge	After first 5000 miles (8 000 km) and after each 50,000 miles (80 000 km)	-----
27	Power Steering and Condenser Fan Motor Oil Filter	Change cartridge	50,000 miles (80 000 km)	-----
28	Retarder Valve Shaft	Apply	100,000 miles (160 000 km) or once a year	L-2
29	Secondary Fuel Oil Filter	Change cartridge	10,000 miles (16 000 km)	Fill with clean fuel oil
30	Pillow Block of A/C Compressor Support	Two (2) fittings	5000 miles (8 000 km)	L-5
31	Propeller Shaft U-Joints	Two (2) fittings on each extremity of both propeller shafts	5000 miles (8 000 km)	L-5
32	Propeller Shaft Slip Joints	One fitting on each propeller shaft	5000 miles (8 000 km)	L-5
33	Differential Oil Fill Plugs	Drain and refill differentials	Break-in period 1000 miles (1 600 km), then after each 25,000 miles (40 000 km) 5000 miles (8 000 km)	(see NOTE 8)
34	Rear Forward Differential Oil Filter	Change cartridge	25,000 miles (40 000 km) when differential oil change	(see NOTE 9)
35	Turning Table Grease Manifold	One fitting	10,000 miles (16 000 km)	L-5
36	Central Joint-Lever Bearing	One fitting	10,000 miles (16 000 km)	L-5
37	Drag Link Pivot Bearing	One fitting on center of pivot	5000 miles (8 000 km)	L-5
38	Rear Door Rotating Column	One fitting on center of rotating column	50,000 miles (80 000 km) or twice a year	L-1
39	Front Door Rotating Column	One fitting on center of rotating column	50,000 miles (80 000 km) or twice a year	L-1
40	Driver's A/C and Heating Unit Air Filter	Clean or replace	10,000 miles (16 000 km)	-----
41	Air Tank Drain Valves	Drain accumulated water	Daily	-----
42	In-Station Connector	Plug external power supply to use in-station lighting, engine and water tank heaters	As required	(see NOTE 10)
43	Windshield Washer Reservoir	Filler cap/reservoir	Daily	-----
44	Accessory Air Filter and Fill-Valve	Change cartridge element	As required	(see NOTE 11)

ITEM	DESCRIPTION	REMARKS	INTERVALS	LUBRICANT
45	Main Front A/C and Heating Unit Filters (L.H. and R.H.)	Replace	10,000 miles (16 000 km)	-----
46	Battery Terminals and Sliding Tray	Keep battery terminals coated and apply "Lubriplate" on slides of tray	5000 miles (8 000 km)	Battery terminal coating and L-3
47	Air Conditioning Compressor	Check oil level in sight glass	5000 miles (8 000 km)	A-1 (see NOTE 12)
48	Air System Emergency Fill Valve	Use to fill air system tanks	As required	(see NOTE 13)
49	Cold Weather Starting Fluid Cup	Use with ether capsule	Use when cold weather occurs	-----
50	Air Restriction Indicator	Check when red signal locks in full view	Daily (When red signal locks in full view, change air cleaner element)	(see NOTE 14)
51	Receiver Tank (R-22)	Check sight glass when filling	When adding refrigerant	-----
52	Coolant Filters (strainer)	Clean strainer	After first 3000 miles (5 000 km) and each 100,000 miles (160 000 km)	-----
53	Pre-Cleaner	Check discharge tube	5000 miles (8 000 km)	-----
54	Spin-On Type Coolant Filters ("Perry" filter)	Change both cartridges	20,000 miles (32 000 km)	-----
55	Air Cleaner (Dry type)	Replace element	5000 miles (8 000 km)	-----
56	Hubodometer	Check accumulated mileage	Daily	-----
57	Surge Tank	Use to add coolant	As required	(see NOTE 15)
58	Main Rear A/C and Heating Unit Filters (L.H. and R.H.)	Replace	10,000 miles (16 000 km)	-----
59	Sump Tank (filling and draining)	Fill or drain	Daily	-----
60	Fresh Water Reservoir (filling and draining)	Fill or drain	Daily	-----
61	Access panel for rear camera maintenance switch	Use when camera lens needs cleaning	Periodically	-----
62	Air Dryer (AD-4)	Inspect element and replace if necessary	25,000 miles (40 000 km)	-----
63	Crankcase breathers	Inspect and replace if necessary	30,000 miles (50 000 km)	-----
64	Engine Oil Filter	Change cartridge	10,000 miles (16 000 km)	Fill with O-1
65	Spare Tire Winch Gears and Ratchet Mechanism	Apply	Once a year	L-5
66	Steering Damper End	One fitting	5000 miles (8 000 km)	L-5
67	Power Steering Cylinder End	One fitting	5000 miles (8 000 km)	L-5

## NOTES

- A high temperature waterproof grease in NLGI grade #1 (Rockwell Material Specification Number 0-616-A) is recommended for lubricating Dura-Master Air Disc Brakes and Automatic Slack Adjusters. It should be a smooth textured, corrosion resistant grease, free of fillers and abrasives. The grease should maintain a satisfactory softness under normal parking and storage temperatures so the brakes can be applied and released. A suitable grease can be obtained under Prevost part number 68-0500 or Rockwell International, part number A-1779-W-283.
- Fill front and rear wheel bearings (axles 1, 2 and 5) to the level mark in cap with SAE 90 differential oil. Drive axle wheel bearings are lubricated by the oil in the differentials. Maintain differential oil levels to ensure adequate oil supply to rear wheel bearings at all times.
- Use ONLY special silicon grease Prevost part number 68-0460.
- On transfer shaft U-joints, at the extremity of reserve tank, the grease fitting must be filled from under the transfer shaft guard as well as the slip joint. However at the other extremity, there is a hole on top of transfer shaft guard to lubricate easily the fitting.
- When starter is removed for service, remove "Allen plugs" in nose housing and commutator end frame of starter and saturate wicks.
- Refer to page 6-4 in the "Operator's Manual", under heading "Automatic transmission oil level check" for cold and hot check procedures.
- Do not overfill; fill only to "HIGH" or "FILL" mark on dipstick.
- Multigrade gear lubricants which meet the requirements of military specification MIL-L-2105-C are recommended for use in drive axles. These lubricants perform well over broad temperature ranges, providing good gear and bearing protection in a variety of climates. The MIL-L-2105-C specification divides lubricants into three major categories according to their viscosity at various temperatures. These are 75W, 80W90 and 85W140. 80W140 lubricants are also available, but are listed with 80W90 in MIL-L-2105-C specification. Lubricants approved under MIL-L-2105-B are also acceptable for use.
- Replace differential cartridge each 25,000 miles (40 000 km), or whenever differential oil is changed. Use the Prevost part number 62-1323 or Rockwell International, part number PH-30.
- The external power supply must have a 110-120 volt, 30 amp minimum rating. Use only a three-prong grounded-type extension cord.
- Change element whenever differential pressure exceeds 15 psi (100 kPa) between the inlet and outlet of air filter.
- Use ONLY approved oils; refer to "Recommended Lubricant Code" or to the "Operation and Service Manual of 05G Bus Compressor" for lubricant type list.
- This vehicle is equipped with an air emergency fill valve to supplement air system when air pressure is low and engine cannot be operated. This air system emergency fill valve can be connected to any regular size external air supply line and will supply air for all systems, (brakes, suspension, kneeling, accessories). Pressure of the external air supply must be 120 psi (830 kPa) maximum.
- When red signal locks in full view, the air cleaner element must be replaced and the indicator must be reset by pressing on its extremity.
- On vehicles equipped with DDEC system, it is very important to keep surge tank coolant to a proper level. If coolant level becomes too low, a coolant sensor will inform the DDEC module which will shut off the engine.

## RECOMMENDED LUBRICANT CODE

- O-1 Heavy-duty engine oil MIL-L-2104-C or MIL-L-46152 (not MS)
  - O-2 Graphite grease
  - O-5 Dexron II or Dexron automatic transmission oil
  - L-1 Lubriplate #1242
  - L-2 High melting point, water resistant, lithium base grease
  - L-3 Lubriplate #105
  - L-5 Molybdenum disulphide grease
  - G-1 General purpose gear lubricant SAE 90 (A.P.I. spec GL5)
  - G-2 General purpose gear lubricant SAE 140 (A.P.I. spec GL5)
  - A-1 Air conditioning compressor oil
- Approved oils**
- |                 |                         |
|-----------------|-------------------------|
| <b>Marketer</b> | <b>Trade Name</b>       |
| Calumet         | R030                    |
| Dupont          | Zephron 150             |
| Sun Oil Co.     | Suniso 3GS & Suniso 4GS |
| Texaco          | WFI 132                 |
- A-2 ABS Sensors special silicon grease**
- F-1 Disc brakes, power shafts, and slack adjuster grease (NLGI grade #1)**
- Recommended greases**
- |                 |                   |
|-----------------|-------------------|
| <b>Marketer</b> | <b>Trade Name</b> |
| Texaco          | Thermotex EP#1    |
| Shell           | Shell Darina #1   |
| Sunoco          | Sunaplex #1EP     |
- F-2 Special "KYSOR" shutterstat air filter fluid**
- H-1 SAE 10 oil**
- H-2 SAE 10W30 or SAE 5W30 (moderate climate) oil**
- W-1 Windshield washer fluid**
- W-2 Engine coolant (ethylene glycol permanent type antifreeze solution, low silicate type)**

# 19

# LUBRICATION

## CONTENTS OF THIS SECTION

DESCRIPTION . . . . .	19-1
DIFFERENTIAL BREAK-IN PERIOD . . . . .	19-1
LUBRICATION INTERVALS . . . . .	19-1
OIL CHANGES . . . . .	19-1
OIL RESERVE TANK . . . . .	19-1
COLD WEATHER OPERATION . . . . .	19-1
FLEXIBLE HOSE MAINTENANCE . . . . .	19-1
ARTICULATION LUBRICATION . . . . .	19-2



## DESCRIPTION

A lubrication chart is included in this section to indicate the location of fittings and service points that require periodic lubrication.

Where cleaning, removal or disassembly are required for lubrication purposes, these procedures are covered in the applicable sections of this manual. The engine and transmission, as well as the power steering fluid reservoir and the fan gear box are provided with dipsticks for checking lubricant level.

## DIFFERENTIAL BREAK-IN PERIOD

Lubricant in the differentials is supplied as "Factory Fill" and should be drained and refilled after 1,000 miles (1 600 km) and must not exceed 3,000 miles (5 000 km) of initial operation. So, drain accordingly to break-in period, then the recommended lube change interval (after the initial change) should be every 25,000 -30,000 miles (40 000 - 48 000 km) when yearly mileage is in excess of 60,000 miles (96 000 km). If yearly mileage is less than 60,000 miles (96 000 km), change twice a year (spring and fall). When proceeding to lube change, drain and refill to top of filler neck or bottom of tapped hole.

## LUBRICATION INTERVALS

Lubrication intervals are based on recommendations for normal operating conditions. Where more severe service is encountered, more frequent intervals will be required. Engine crankcase oil should be checked daily or before the start of each run and oil added to bring the level to the "Full" mark on the dipstick. A new oil filter element should be installed each time the engine oil is changed.

## OIL CHANGES

The engine oil change period is related to the operating conditions, such as vehicle load, speed, etc., and may vary. It is recommended however, that the oil change be performed after every 300 operating hours at an average vehicle operating speed (12,000 miles or 20 000 km approx.).

The drain interval may then be gradually increased or decreased with experience on a specific lubricant, considering the recommendations of the oil supplier (analysis of drained oil can be helpful), until the most practical service condition has been established.

Solvents should not be used as flushing oils. Dilution of the fresh refill oil supply can occur, which may be

detrimental for the engine. A spin-on type oil filter is used on Detroit Diesel engines.

Engine oil temperature should be checked every 25,000 miles (40 000 km) to determine oil cooler efficiency. This check should be made by inserting a steel jacketed thermometer in the dipstick opening, immediately after stopping a hot, loaded engine. If the oil temperature exceeds the coolant temperature by more than 60 °F (33 °C), the oil cooler may be clogged.

For detailed oil specifications, refer to "Detroit Diesel Series 92 Service Manual" under heading "Lubricating oil for Detroit Diesel engines".

## OIL RESERVE TANK

An oil reserve tank with a capacity of 2.5 U.S. gallon (9.45 liters) is connected to the crankcase by a hose with a shut-off valve, allowing oil to be added to crankcase by opening valve. Comparison of oil levels in sight gauge, before and after adding oil to crankcase, shows approximately how much oil has been added.

Filling of this tank can be made by opening the condenser door in order to have access to the engine. The tank is over the transfer shaft beside the front of engine.

## COLD WEATHER OPERATION

Cold weather starting will be facilitated when immersion type electric coolant heaters can be used. Other practical considerations, such as the use of batteries, cables and connectors of adequate size, proper setting of voltage regulators, ether starting aids, oil and coolant heater systems, and proper fuel selection will accomplish starting with the use of SAE 40 or SAE 30 oils. For complete cold weather starting information, consult your operator's manual or an authorized Detroit Diesel service outlet.

## FLEXIBLE HOSE MAINTENANCE

The performance of engine and equipment are greatly related to the ability of flexible hoses to supply lubricating oil, air, coolant, and fuel oil. Maintenance of hoses is an important step to ensure efficient, economical, and safe operation of the engine and related equipment.

## Pre-starting inspection

Check hoses daily as part of the pre-starting inspection. Examine hose for leaks, and check all fittings, clamps, and ties carefully. Ensure that hoses are not resting on or touching shafts, couplings, heated surfaces including exhaust manifolds, any sharp edges, or other obviously damaging areas. Since all machinery vibrates and moves to a certain extent, clamps and ties can fatigue

with time. To ensure proper support, inspect fasteners frequently and tighten or replace them as necessary.

## Leaks

Investigate leaks immediately to determine if fittings have loosened or cracked, and also if hoses have ruptured or worn through. Take corrective action immediately. Leaks are not only potentially detrimental to machine operation, but can also result in added expenses caused by the need to replace lost fluids.

**CAUTION: Personal injury and/or property damage may result from fire due to the leakage of flammable fluids, such as fuel or lube oil.**

## Service life

The limited service life of a hose is determined by the temperature and pressure of the gas or fluid within it, the time in service, its installation, the ambient temperatures, amount of flexing, and the vibration it is subjected to. With this in mind, it is recommended that all hoses be thoroughly inspected at least every 500 operating hours or after 15,000 miles (24 000 km). Look for surface damages or indications of damaged, twisted, worn, crimped, brittle, cracked, or leaking lines. Hoses having the outer surface worn through or a damaged metal reinforcement should be considered unfit for further service.

It is also recommended that all hoses in this vehicle be replaced during major overhaul and/or after a maximum of five service years. Quality of replacement hose assemblies should always be equal to or superior to the Manufacturer's Original Equipment.

## ARTICULATION LUBRICATION

### Intervals

The articulation mechanism should be lubricated at every 7,000 to 20,000 miles (10,000 to 30,000 km) interval, according to the operating conditions, or every three months, whichever occurs first.

### Description

A grease fitting manifold is attached to the articulation frame on the L.H. side to provide lubricant to all grease fittings around the turning table. Furthermore, some lubrication lines, such as those for the articulation turning table, the pivot bearing and the articulation damper shock extremities are connected to this grease fitting manifold.

To ease lubrication procedure, a main fitting at the end of manifold has been provided and is accessible from two locations:

- a) a front access panel inside vehicle over the articulation
- b) a service panel in the first L.H. side baggage compartment of rear section.

Another grease fitting for the connecting arm pivot pin is also accessible under the front inside access panel. The contact surfaces of the turntable teflon ring should be greased by means of a small paintbrush, in order to prevent noisy operation. All other articulation components and linkages are prelubricated and require no further lubrication.

Refer to the lubrication chart for the lubrication intervals and the recommended lubricants.

# LUBRICATION CHART AND SERVICE CHECK POINTS

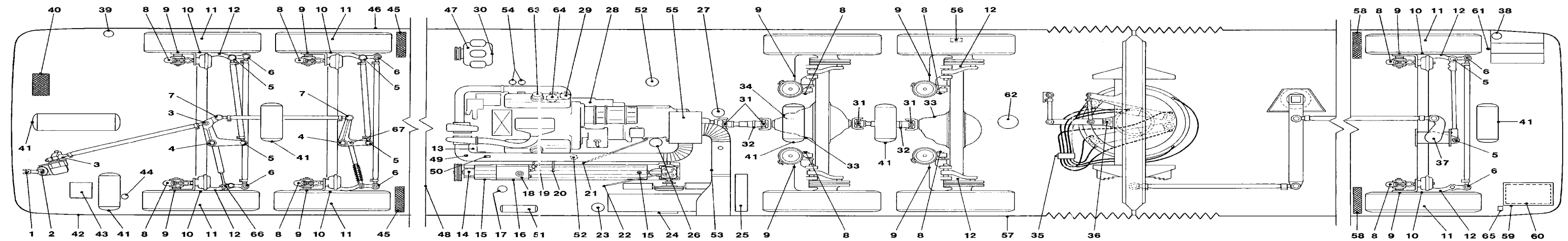

ITEM	DESCRIPTION	REMARKS	INTERVALS	LUBRICANT
1	Upper Steering Column U-Joint	One fitting	5000 miles (8 000 km)	L-5
2	Lower Steering Column U-Joint	One fitting	5000 miles (8 000 km)	L-5
3	Steering Drag Link Ends	One fitting on each end	5000 miles (8 000 km)	L-5
4	Drag Link Transfer Lever Bearings (axles 1 and 2)	One fitting per transfer lever bearing	5000 miles (8 000 km)	L-5
5	Steering Arm Ends (axles 1, 2 and 5)	One fitting on each end	5000 miles (8 000 km)	L-5
6	Tie Rod Ends (axles 1, 2 and 5)	One fitting on each end	5000 miles (8 000 km)	L-5
7	Transfer Lever Connecting Rod Ends	One fitting on each end	5000 miles (8 000 km)	L-5
8	Slack Adjusters (all wheels)	One fitting on each slack adjuster	5000 miles (8 000 km)	F-1
9	Disc Brake Power Shafts	One fitting on each power shaft	25,000 miles (40 000 km)	F-1 (see NOTE 1)
10	Steering Knuckle Pins (axles 1, 2 and 5)	Two fittings per knuckle	5000 miles (8 000 km)	L-5
11	Wheel Bearings (axles 1, 2 and 5)	Fill to mark	Daily	G-1 (see NOTE 2)
12	ABS Sensors	Apply	Only at senso disassembly and assembly	A-2 (see NOTE 3)
13	Radiator Shutter Air Filter	Remove plug - inject 1 1/2 oz U.S. (45 ml) fluid	5000 miles (8 000 km)	F-2
14	Fan Transfer Pillow Block	One fitting on top	5000 miles (8 000 km)	L-5
15	Transfer Shaft U-Joints (both extremities)	One fitting on each end	5000 miles (8 000 km)	L-5 (see NOTE 4)
16	Transfer Shaft Slip Joint	One fitting	5000 miles (8 000 km)	L-5
17	Preheater Fuel Oil Filter	Change cartridge element	100,000 miles (160 000 km)	Fill with clean fuel oil
18	Oil Reserve Tank	Check daily	Daily	Fill with O-1
19	Starter	"Allen" plugs: 8 to 10 drops	During overhaul or 100,000 miles (160 000 km)	H-1 (see NOTE 5)
20	Check Engine Crankcase Oil Level	Keep to "FULL" mark on dipstick	Daily and change after 10,000 miles (16 000 km)	O-1
21	Check Transmission Oil Level	Keep to "FULL" mark on dipstick	Daily	O-5 (see NOTE 6)
22	Check Gearbox Oil Level	Keep to "FULL" mark on dipstick	5000 miles (8 000 km)	G-1
23	Fuel Filter/Water Separator	Drain accumulated water	When accumulated water or warning light illuminated	-----
24	Lubricate Shutter Rods and Cranks	Apply	5000 miles (8 000 km)	O-5
25	Power Steering and Condenser Fan Motor Oil Tank	Keep to "FULL" mark on dipstick	5000 miles (8 000 km)	H-2 (see NOTE 7)
26	Transmission Oil Filter	Change cartridge	After first 5000 miles (8 000 km) and after each 50,000 miles (80 000 km)	-----
27	Power Steering and Condenser Fan Motor Oil Filter	Change cartridge	50,000 miles (80 000 km)	-----
28	Retarder Valve Shaft	Apply	100,000 miles (160 000 km) or once a year	L-2
29	Secondary Fuel Oil Filter	Change cartridge	10,000 miles (16 000 km)	Fill with clean fuel oil
30	Pillow Block of A/C Compressor Support	Two (2) fittings	5000 miles (8 000 km)	L-5
31	Propeller Shaft U-Joints	Two (2) fittings on each extremity of both propeller shafts	5000 miles (8 000 km)	L-5
32	Propeller Shaft Slip Joints	One fitting on each propeller shaft	5000 miles (8 000 km)	L-5
33	Differential Oil Fill Plugs	Drain and refill differentials	Break-in period 1000 miles (1 600 km), then after each 25,000 miles (40 000 km) 5000 miles (8 000 km)	(see NOTE 8)
34	Rear Forward Differential Oil Filter	To level of filler plug	25,000 miles (40 000 km) when differential oil change	(see NOTE 9)
35	Turning Table Grease Manifold	One fitting	10,000 miles (16 000 km)	L-5
36	Central Joint Lever Bearing	One fitting	10,000 miles (16 000 km)	L-5
37	Drag Link Pivot Bearing	One fitting on center of pivot	5000 miles (8 000 km)	L-5
38	Rear Door Rotating Column	One fitting on center of rotating column	50,000 miles (80 000 km) or twice a year	L-1
39	Front Door Rotating Column	One fitting on center of rotating column	50,000 miles (80 000 km) or twice a year	L-1
40	Driver's A/C and Heating Unit Air Filter	Clean or replace	10,000 miles (16 000 km)	-----
41	Air Tank Drain Valves	Drain accumulated water	Daily	-----
42	In-Station Connector	Plug external power supply to use in-station lighting, engine and water tank heaters	As required	(see NOTE 10)
43	Windshield Washer Reservoir	Filler cap/reservoir	Daily	-----
44	Accessory Air Filter and Fill-Valve	Change cartridge element	As required	(see NOTE 11)

ITEM	DESCRIPTION	REMARKS	INTERVALS	LUBRICANT
45	Main Front A/C and Heating Unit Filters (L.H. and R.H.)	Replace	10,000 miles (16 000 km)	-----
46	Battery Terminals and Sliding Tray	Keep battery terminals coated and apply "Lubriplate" on slides of tray	5000 miles (8 000 km)	Battery terminal coating and L-3
47	Air Conditioning Compressor	Check oil level in sight glass	5000 miles (8 000 km)	A-1 (see NOTE 12)
48	Air System Emergency Fill Valve	Use to fill air system tanks	As required	(see NOTE 13)
49	Cold Weather Starting Fluid Cup	Use with ether capsule	Use when cold weather occurs	-----
50	Air Restriction Indicator	Check when red signal locks in full view	Daily (When red signal locks in full view, change air cleaner element)	(see NOTE 14)
51	Receiver Tank (R-22)	Check sight glass when filling	When adding refrigerant	-----
52	Coolant Filters (strainer)	Clean strainer	After first 3000 miles (5 000 km) and each 100,000 miles (160 000 km)	-----
53	Pre-Cleaner	Check discharge tube	5000 miles (8 000 km)	-----
54	Spin-On Type Coolant Filters ("Perry" filter)	Change both cartridges	20,000 miles (32 000 km)	-----
55	Air Cleaner (Dry type)	Replace element	5000 miles (8 000 km)	-----
56	Hubodometer Surge Valve	Check accumulated mileage	Daily	-----
57	Hubodometer Surge Valve	Use to add coolant	As required	(see NOTE 15)
58	Main Rear A/C and Heating Unit Filters (L.H. and R.H.)	Replace	10,000 miles (16 000 km)	-----
59	Sump Tank (filling and draining)	Fill or drain	Daily	-----
60	Fresh Water Reservoir (filling and draining)	Fill or drain	Daily	-----
61	Access panel for rear camera maintenance switch	Use when camera lens needs cleaning	Periodically	-----
62	Air Dryer (AD-4)	Inspect element and replace if necessary	25,000 miles (40 000 km)	-----
63	Crankcase breathers	Inspect and replace if necessary	30,000 miles (50 000 km)	-----
64	Engine Oil Filter	Change cartridge	10,000 miles (16 000 km)	Fill with O-1
65	Spare Tire Winch Gears and Ratchet Mechanism	Apply	Once a year	L-5
66	Steering Damper End	One fitting	5000 miles (8 000 km)	L-5
67	Power Steering Cylinder End	One fitting	5000 miles (8 000 km)	L-5

## NOTES

- A high temperature waterproof grease in NLGI grade #1 (Rockwell Material Specification Number 0-616-A) is recommended for lubricating Dura-Master Air Disc Brakes and Automatic Slack Adjusters. It should be a smooth textured, corrosion resistant grease, free of fillers and abrasives. The grease should maintain a satisfactory softness under normal parking and storage temperatures so the brakes can be applied and released. A suitable grease can be obtained under Prevost part number 68-0500 or Rockwell International, part number A-1779-W-283.
- Fill front and rear wheel bearings (axles 1, 2 and 5) to the level mark in cap with SAE 90 differential oil. Drive axle wheel bearings are lubricated by the oil in the differentials. Maintain differential oil levels to ensure adequate oil supply to rear wheel bearings at all times.
- Use ONLY special silicon grease Prevost part number 68-0460.
- On transfer shaft U-joints, at the extremity of reserve tank, the grease fitting must be filled from under the transfer shaft guard as well as the slip joint. However at the other extremity, there is a hole on top of transfer shaft guard to lubricate easily the fitting.
- When starter is removed for service, remove "Allen plugs" in nose housing and commutator end frame of starter and saturate wicks.
- Refer to page 6-4 in the "Operator's Manual", under heading "Automatic transmission oil level check" for cold and hot check procedures.
- Do not overfill; fill only to "HIGH" or "FILL" mark on dipstick.
- Multigrade gear lubricants which meet the requirements of military specification MIL-L-2105-C are recommended for use in drive axles. These lubricants perform well over broad temperature ranges, providing good gear and bearing protection in a variety of climates. The MIL-L-2105-C specification divides lubricants into three major categories according to their viscosity at various temperatures. These are 75W, 80W90 and 85W140. 80W140 lubricants are also available, but are listed with 80W90 in MIL-L-2105-C specification. Lubricants approved under MIL-L-2105-B are also acceptable for use.
- Replace differential cartridge each 25,000 miles (40 000 km), or whenever differential oil is changed. Use the Prevost part number 62-1323 or Rockwell International, part number PH-30.
- The external power supply must have a 110-120 volt, 30 amp minimum rating. Use only a three-prong grounded-type extension cord.
- Change element whenever differential pressure exceeds 15 psi (100 kPa) between the inlet and outlet of air filter.
- Use ONLY approved oils; refer to "Recommended Lubricant Code" or to the "Operation and Service Manual of 05G Bus Compressor" for lubricant type list.
- This vehicle is equipped with an air emergency fill valve to supplement air system when air pressure is low and engine cannot be operated. This air system emergency fill valve can be connected to any regular size external air supply line and will supply air for all systems, (brakes, suspension, kneeling, accessories). Pressure of the external air supply must be 120 psi (830 kPa) maximum.
- When red signal locks in full view, the air cleaner element must be replaced and the indicator must be reset by pressing on its extremity.
- On vehicles equipped with DDEC system, it is very important to keep surge tank coolant to a proper level. If coolant level becomes too low, a coolant sensor will inform the DDEC module which will shut off the engine.

## RECOMMENDED LUBRICANT CODE

- O-1 Heavy-duty engine oil MIL-L-2104-C or MIL-L-46152 (not MS)
  - O-2 Graphite grease
  - O-5 Dexron II or Dexron automatic transmission oil
  - L-1 Lubriplate #1242
  - L-2 High melting point, water resistant, lithium base grease
  - L-3 Lubriplate #105
  - L-5 Molybdenum disulphide grease
  - G-1 General purpose gear lubricant SAE 90 (A.P.I. spec GL5)
  - G-2 General purpose gear lubricant SAE 140 (A.P.I. spec GL5)
  - A-1 Air conditioning compressor oil
- Approved oils**
- |                 |                         |
|-----------------|-------------------------|
| <b>Marketer</b> | <b>Trade Name</b>       |
| Calumet         | R030                    |
| Dupont          | Zephron 150             |
| Sun Oil Co.     | Suniso 3GS & Suniso 4GS |
| Texaco          | WFI 132                 |
- A-2** ABS Sensors special silicon grease
- F-1** Disc brakes, power shafts, and slack adjuster grease (NLGI grade #1)
- Recommended greases**
- |                 |                   |
|-----------------|-------------------|
| <b>Marketer</b> | <b>Trade Name</b> |
| Texaco          | Thermax EP#1      |
| Shell           | Shell Darina #1   |
| Sunoco          | Sunaplex #1EP     |
- F-2** Special "KYSOR" shutterstat air filter fluid
- H-1** SAE 10 oil
- H-2** SAE 10W30 or SAE 5W30 (moderate climate) oil
- W-1** Windshield washer fluid
- W-2** Engine coolant (ethylene glycol permanent type antifreeze solution, low silicate type)