

# PREVOST

## Instruction Sheet

## IS-21089A

### EFD H3 VIP CONDENSER REPOSITIONING





Revision: A



GENERAL REVISION AND ADD FRENCH VERSION

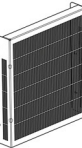
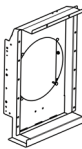
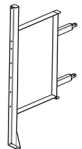

07-31-2024

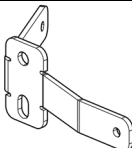

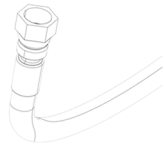
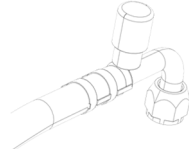
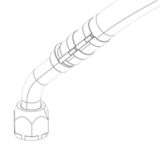
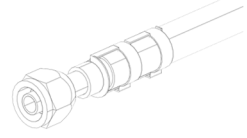

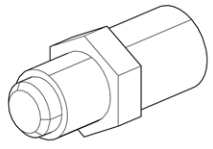
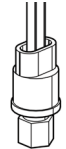
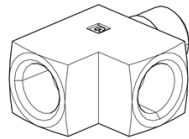
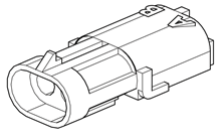
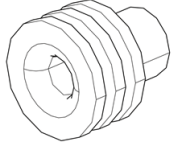
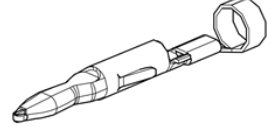

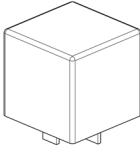
### MATERIAL

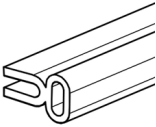
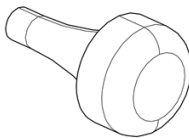
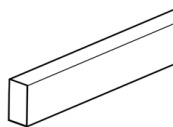
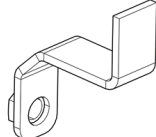
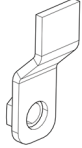
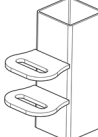
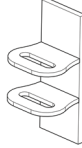
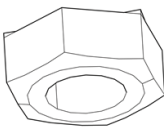
Kit #IS21089 includes the following parts:

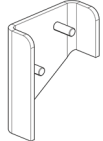
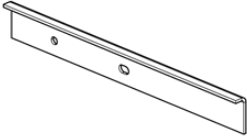
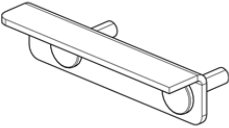
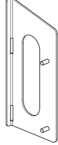
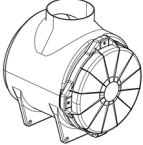

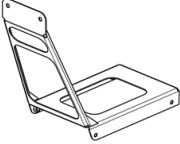

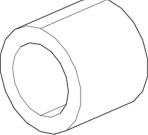
| Part No | Description             |   | Qty |
|---------|-------------------------|---|-----|
| 950552  | CONDENSER               |    | 1   |
| 565881  | FAN CONDENSOR 12"       |    | 1   |
| 454036  | PROTECTIVE PANEL        |   | 1   |
| 454037  | SHROUD ASSY.            |  | 1   |
| 454864  | CONDENSER SUPPORT ASSY. |  | 1   |
| 454888  | AIR DRYER BRACKET       |  | 1   |
| 454892  | TOP BRACKET             |  | 1   |
| 454893  | BRACKET                 |  | 1   |

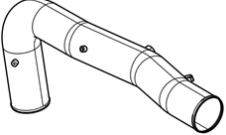

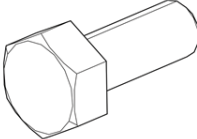
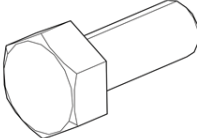
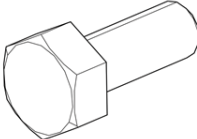
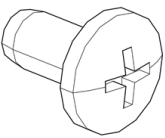
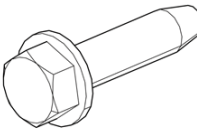
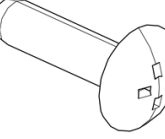
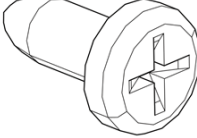
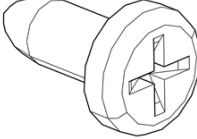

|        |                           |   |   |
|--------|---------------------------|---|---|
| 454032 | HOSE ASSEMBLY 3180MM      |    | 1 |
| 454031 | HOSE ASSEMBLY 2570MM      |    | 1 |
| 454030 | HOSE ASSEMBLY 1550MM      |    | 1 |
| 455031 | HOSE ASSEMBLY 3700MM      |    | 1 |
| 950370 | FILTRE DRYER              |    | 1 |
| 950249 | VALVE                     |   | 1 |
| 950270 | PRESSURE SWITCH           |  | 1 |
| 501338 | TEE 1/4PM x 1/4PF x 1/4PF |  | 1 |
| 561566 | CONNECTOR 2 PH            |  | 1 |
| 561565 | WIRE SEAL 20-16 GREEN     |  | 2 |
| 561567 | TERMINAL PIN 20-18        |  | 2 |

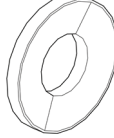

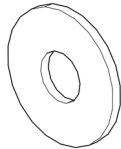
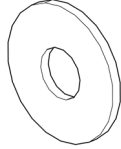
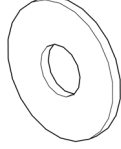
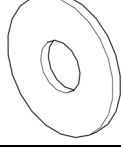

|         |   |   |        |
|---------|---|---|--------|
| 563332  | RELAY, 24V WITH RESISTOR                |    | 2      |
| 562101  | TERMINAL OCKET 16-14                    |    | 1      |
| 0610379 | HARNESS, DRIVER AIR CONDENSER           |   | 1      |
| 2810653 | PANEL, PERFORATED                       |    | 1      |
| 506302  | RUBBER EXTRUSION EPDM BLACK             |    | 7 ft   |
| 504709  | RUBBER BUMPER 9/32 X1 1/16 X 5/8 X 1/16 |    | 2      |
| 506228  | TAPE AD1 PE CC BK 1/4"X1/2"X37.5'       |   | 6.5 ft |
| 218982  | ANGULAR WELDED ASSY.                    |  | 1      |
| 218942  | ANGULAR WELDED ASSY.                    |  | 1      |
| 2810648 | CONDENSER HINGE BRACKET                 |  | 2      |
| 2810658 | CONDENSER HINGE BRACKET UP              |  | 1      |
| 502609  | NUT WELD HEX SS M8-1.25                 |  | 1      |

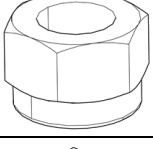
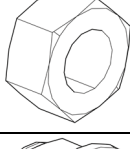
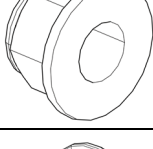
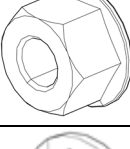
|        |                          |   |   |
|--------|--------------------------|---|---|
| 218948 | AIR DRYER BRACKET        |    | 1 |
| 218944 | AIR FILTER BRACKET       |    | 1 |
| 218943 | INTAKE TUBE BRACKET      |    | 1 |
| 218949 | OIL TANK BRACKET         |    | 1 |
| 531493 | AIR CLEANER              |    | 1 |
| 531363 | REDUCER 7" TO 5"         |   | 1 |
| 030292 | AIR FILTER REAR BRACKET  |  | 1 |
| 030293 | AIR FILTER FRONT BRACKET |  | 1 |
| 032540 | SPACER                   |  | 1 |
| 032541 | BRACKET                  |  | 1 |
| 030053 | AIR INTAKE PIPE          |  | 1 |

|         |                                       |   |   |
|---------|---------------------------------------|---|---|
| 030232  | ADAPTER ASSEMBLY.                     |    | 1 |
| 5011240 | ADAPTER STRAIGHT 3/4 NPT-M X 1"       |    | 1 |
| 030286  | HOSE 7" DIA. 270 MM                   |    | 1 |
| 030291  | HOSE 1016MM                           |    | 1 |
| 030045  | DECAL "NE PAS UTILISER D'ETHER"       |    | 1 |
| 030046  | DECAL "DO NOT USE ETHER"              |   | 1 |
| 034005  | DECAL "PLASTIC BOLT TORQUE"           |  | 1 |
| 286716  | SPACER                                |  | 4 |
| 5001981 | SCREW CAP HEX SS NSS M8-1.25X50       |  | 2 |
| 502862  | SCREW CAP HEX N500 M8-1.25X20 G8.8    |  | 8 |
| 502836  | SCREW CAP HEX N500 M8-1.25X35 G8.8 FT |  | 4 |

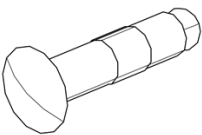
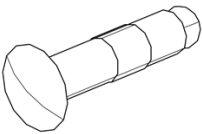
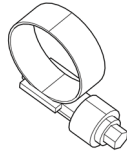
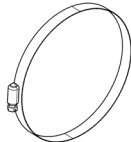
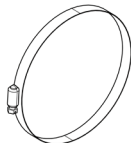
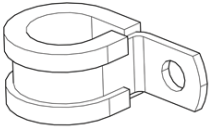
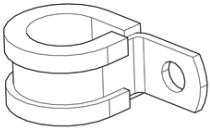
|         |   |   |    |
|---------|---|---|----|
| 5001990 | SCREW CAP HEX NYLON BK M8-1.25X30           |    | 4  |
| 5001697 | SCREW CAP HEX SS NSS M6-1.0X16              |    | 6  |
| 502780  | SCREW CAP HEX SS NSS M8-1.25X25             |    | 4  |
| 5001975 | SCREW TC BDG PH SS410 Z050 10-24X3/8        |    | 14 |
| 500266  | SCREW TC HEXW N500 1/4-20x1                 |    | 3  |
| 500283  | SCREW THREAD CUTTING TR PH SS 10-24X3/4     |   | 12 |
| 502868  | SCREW THREAD CUTTING TR PH N500 #10-16X 1/2 |  | 2  |
| 509805  | SCREW TAPPING PAN PH N050 #10X1/2           |  | 6  |
| 5001833 | WASHER BEL SPRING SS 301 6.65X17.4X1.27     |  | 4  |
| 5001868 | WASHER BEL SS 8.4X18X2                      |  | 4  |
| 500332  | WASHER FLAT N500 .328X.875 X.062            |  | 12 |

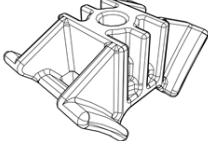
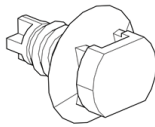
|         |                                   |   |    |
|---------|-----------------------------------|---|----|
| 5001736 | WASHER FLAT N500 8.4X18X2         |    | 10 |
| 5001137 | WASHER FLAT SS .203X.438X.06      |    | 14 |
| 500411  | WASHER FLAT SS .260X.697X.05      |    | 6  |
| 5001849 | WASHER FLAT SS 8.4X24X2           |    | 4  |
| 502853  | WASHER LOCK SPT N500 6.1X11.8X1.6 |    | 6  |
| 500942  | WASHER LOCK SPT N500 8.1X14.8X2   |   | 8  |
| 5001787 | NUT HEX NYRT SS M8-1.25X9.5       |  | 2  |
| 5001851 | NUT HEX SS NSS M6-1.0             |  | 4  |
| 5001931 | NUT HEXF NYRT NX500 M8-1.25 CP 8  |  | 6  |
| 502692  | NUT HEXF STO Z050 M8-1.25EX       |  | 4  |
| 502837  | NUT HEXF STO N500 M8-1.25         |  | 2  |

|        |   |   |    |
|--------|---|---|----|
| 504339 | RIVET POP DOME SS OE 1/8 (0.25-0.375)   |    | 3  |
| 504379 | RIVET POP DOME SS OE 3/16 (0.126-0.250) |    | 2  |
| 504291 | CLAMP HOSE LINER SS/CS 21-44            |    | 2  |
| 504324 | CLAMP HOSE SS/CS 114-165                |    | 1  |
| 504229 | CLAMP HOSE SS/CS 165-216                |    | 3  |
| 952629 | CLAMP / ZP RUB 15.9 ID                  |   | 4  |
| 952631 | CLAMP / ZP RUB 19 ID                    |  | 1  |
| 504013 | CABLE TIE MOUNT, BLACK 1/4"             |  | 2  |
| 509490 | TWO WAY SADDLE MOUNTS, GREY             |  | 1  |
| 509815 | FIR TREE MOUNTING (FT7 TYPE)            |  | 2  |
| 504016 | CABLE TIE, NYLON BLACK (LIGHT-HEAVY)    |  | 20 |

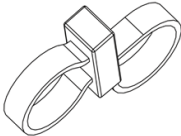

|          |                                    |   |
|----------|------------------------------------|---|
| 504637   | CABLE TIE, NYLON BLACK (STD)       | <br>40 |
| 504768   | CABLE TIE, NYLON BLACK DOUBLE LOOP | <br>15 |
| IS-21089 | Instruction Sheet                  | 1   |
| FI-21089 | Feuille d'instructions             | 1   |

|   |
|---|
| <b><i>NOTE</i></b>  |
| <i>Material can be obtained through regular channels.</i> |

## SAFETY PRECAUTIONS

- Eye protection should always be worn when working in a shop.
- Rules for Personal Protection Equipment should always be respected. Wear your PPE including but not limited to the following:



# Safety First!



## PROCEDURE



### DANGER

Park vehicle safely, apply parking brake, stop engine. Prior to working on the vehicle, set the ignition switch to the OFF position and trip the main circuit breakers equipped with a trip button. On Commuter type vehicles, set the battery master switch (master cut-out) to the OFF position.

Lock out & Tag out (LOTO) must be performed during set-up, maintenance or repair activities. Refer to your local procedure for detailed information regarding the control of hazardous energy.

### *NOTE*

Be aware before to start the project you must remove and relocate all converter appliance inside compressor compartment (ex.: heater, pressure washer... etc.)

## Table of contents

|   |    |
|---|----|
| GENERAL REVISION AND ADD FRENCH VERSION ..... | 1  |
| A. PARTS TO REMOVE .....                      | 12 |
| B. PARTS TO WELD .....                        | 16 |
| C. AIR FILTER INSTALLATION .....              | 32 |
| D. COMPRESSOR DOOR MODIFICATION .....         | 39 |
| E. CONDENSER INSTALLATION .....               | 40 |
| F. DRYER INSTALLATION.....                    | 45 |
| G. HOSES INSTALLATION .....                   | 47 |
| H. HOSES FASTENING .....                      | 49 |
| I. POWER STEERING TANK INSTALLATION.....      | 52 |
| J. WIRING HARNESS INSTALLATION.....           | 53 |
| K. VPG: PARAMETER SETTING .....               | 55 |
| Appendix A.....                               | 56 |

## A. PARTS TO REMOVE

1. Remove all appliances in the compartment, all those systems need to be relocated inside the vehicle.

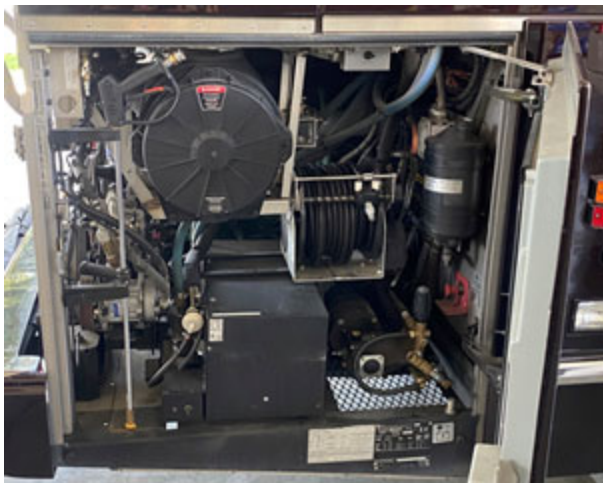

2. Remove air filter installation.

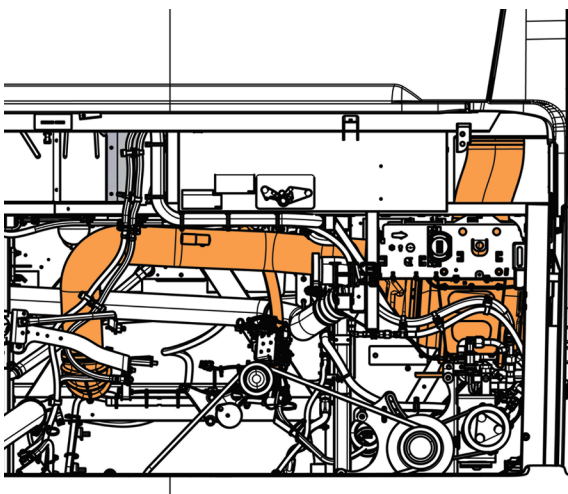

3. Remove those parts from the old turbo pipe connection. keep for re-use:

- Inlet hose
- Clamps

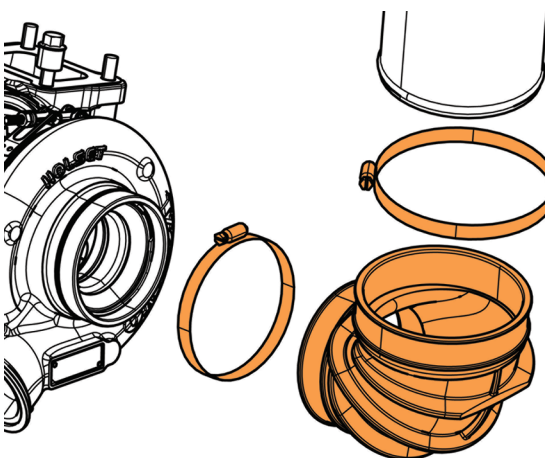

4. Remove the filter restriction indicator. Keep for re-use.

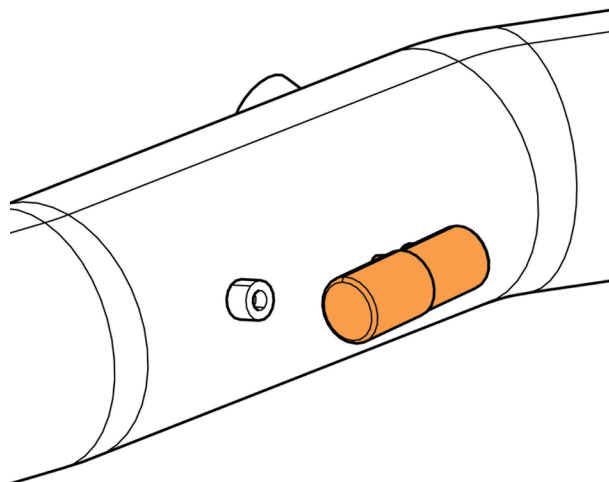

5. Discard the rest of the air intake (hose, pipe and air filter and hardware).

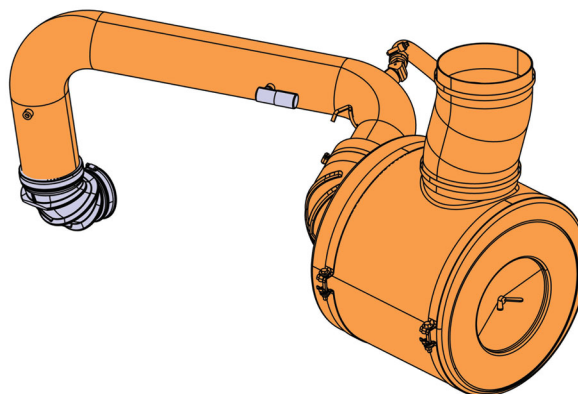

***Vehicle with reinforcement for the rear right slide-out***

6. Disconnect the power steering oil tank
7. Drain the power steering tank oil and remove it.
8. Remove the tank, keep for reuse.

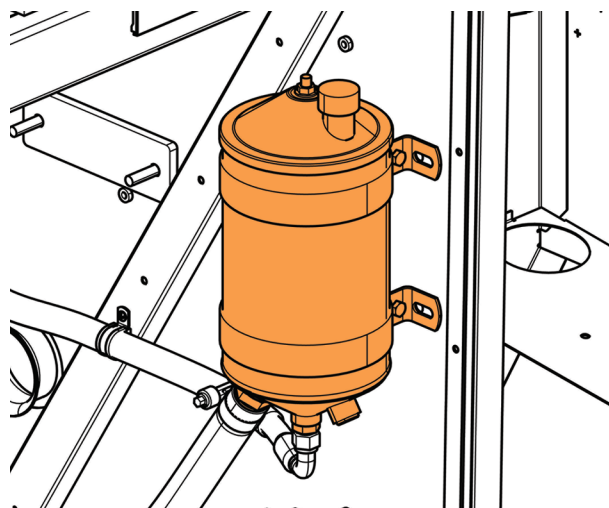

9. Recover refrigerant as required by local authorities.
10. Remove the system.
11. Avoid moisture from getting in the air condition circuit, add a plastic cap on all open fitting and remove it when you are ready to reinstall.

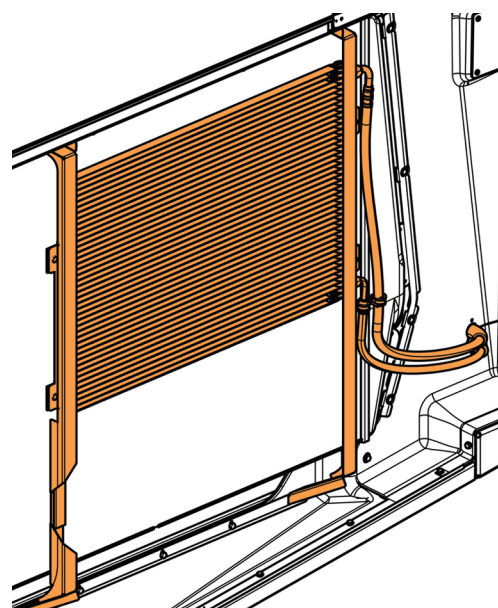
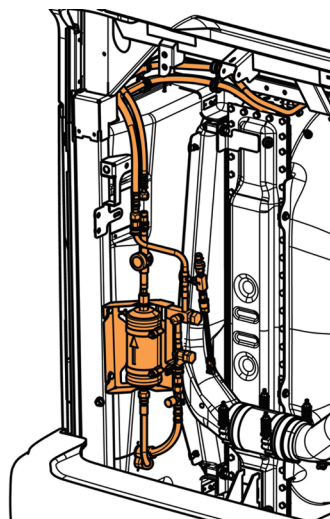

12. Reuse the dryer assembly.
13. Replace the filter dryer by a new one 950370.
14. Avoid moisture from getting in the air condition circuit Add plastic cap on all open fitting and remove it when you are ready to reinstall.

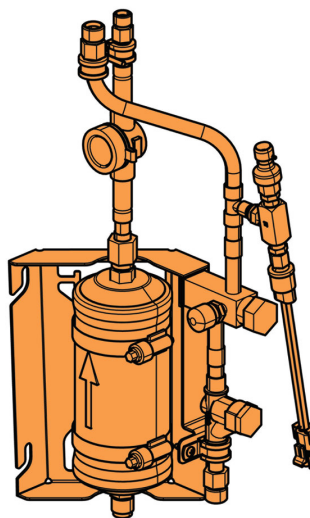

15. Discard the rest of the condenser, hoses, and hardware.

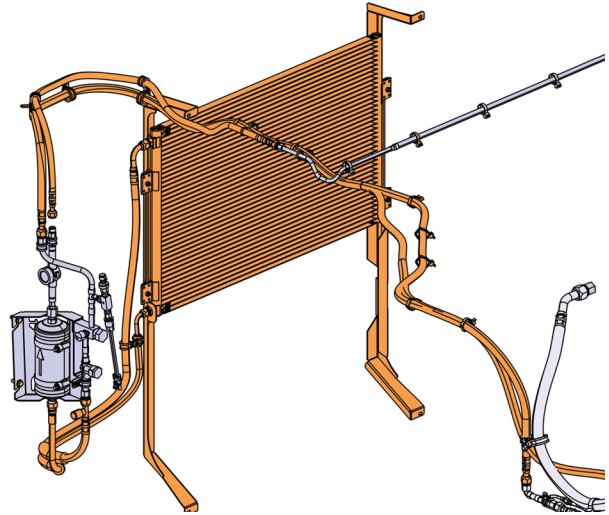

**Vehicle with reinforcement for the rear right slide-out**

16. If necessary, cut those structure tubes.

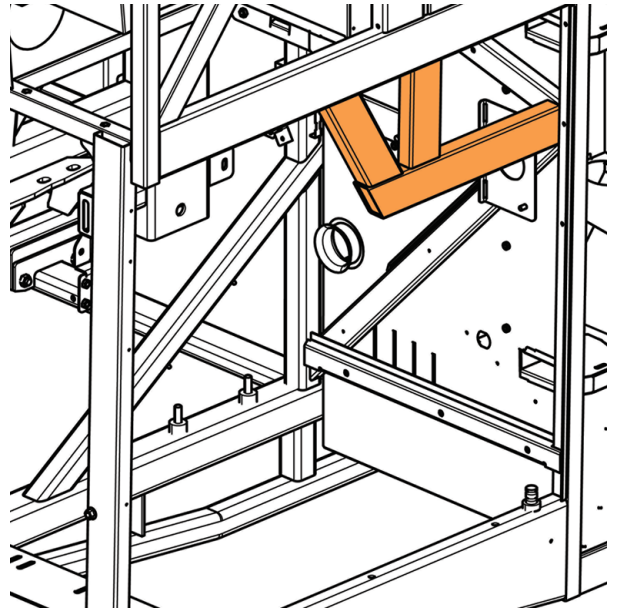

## B. PARTS TO WELD



### CAUTION

Disconnect all electronic modules to prevent any damage prior to welding.

Refer to MULTIPLEX MODULE DISCONNECTION PROCEDURE see maintenance manual section 00a for your vehicle.

Welding setting see Appendix A



### CAUTION

Welding should be performed by a qualified welder using the appropriate personal protection equipment.

Install OSHA safe portable welding screens or curtains around the work area to protect bystanders.

#### **Vehicle without reinforcement for the rear right slide-out**

1. Assemble the bracket 2810648 (2x) to the condenser support assembly 454764 with the bolts 5001981 (2x), the washers 5001849 (4x), the spacers 286716 (4x) and the nuts 5001787 (2x).
2. Assemble the angular 218982 to the condenser support assembly 454764 with the bolt 502862, the lock washer 500942 and the washer 500332.

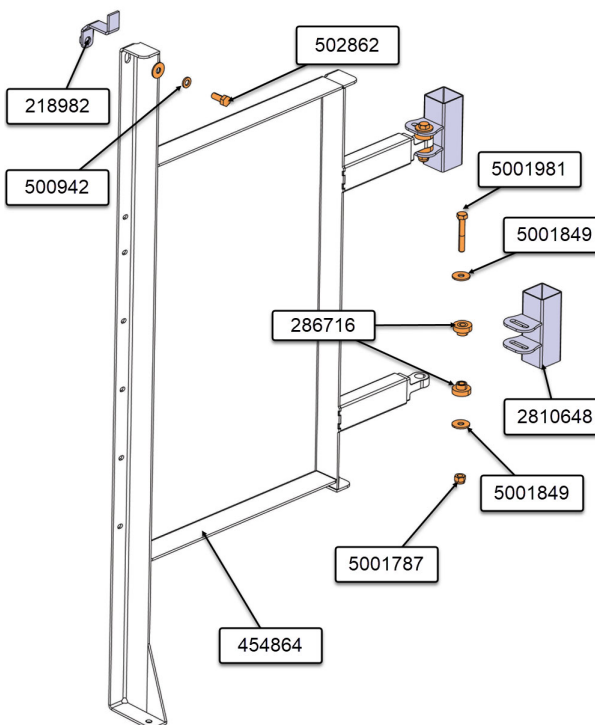



3. Secure the assembly with clamps.

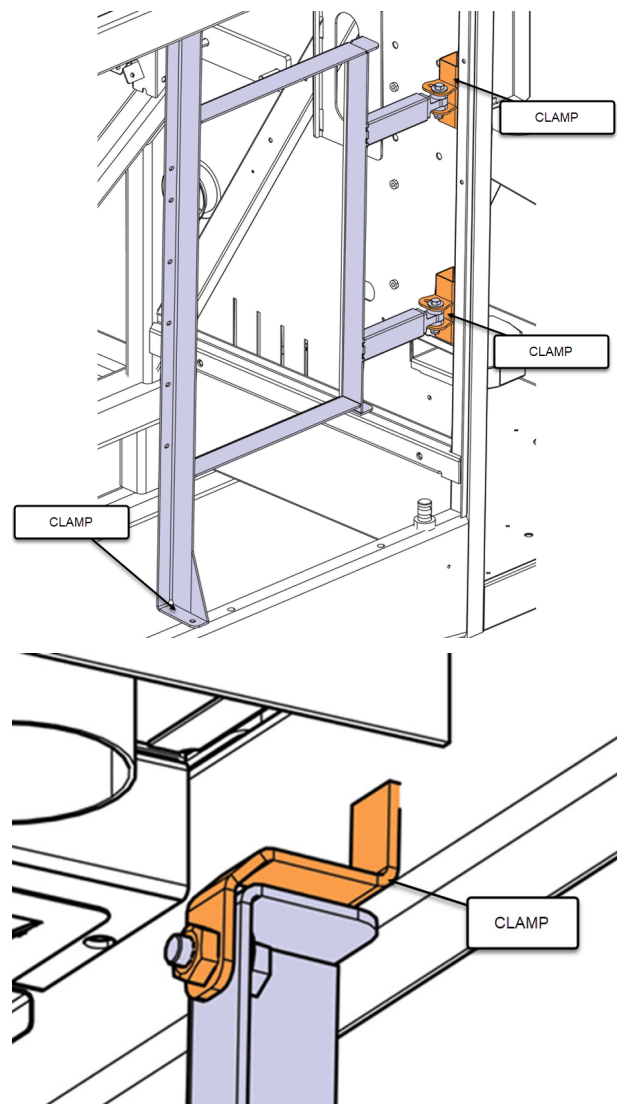

4. Tack welds the brackets 2810648 (2x) and the angular 218982 to the structure.

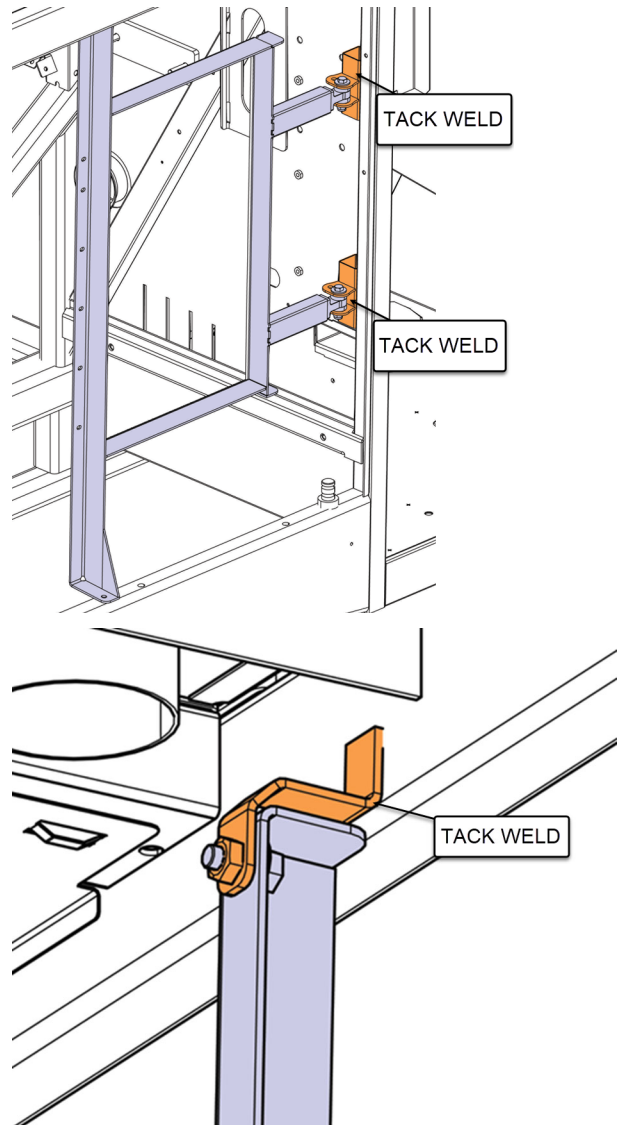

5. Drill 7/16"Ø hole using the frame as a guide.

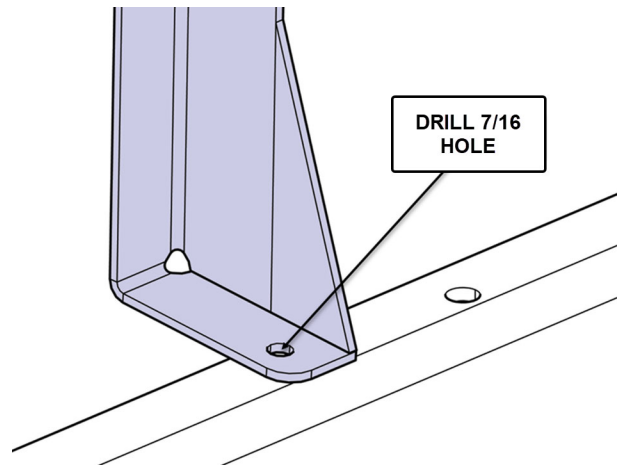

6. Remove the bolts 5001981 (2x), the washers 5001849 (4x), the spacers 286716 (4x), the nuts 5001787 (2x) and the condenser support assembly 454764.
7. Remove the bolt 502862, the lock washer 500942 and the washer 500332 that secure the top of condenser support assembly 454764.

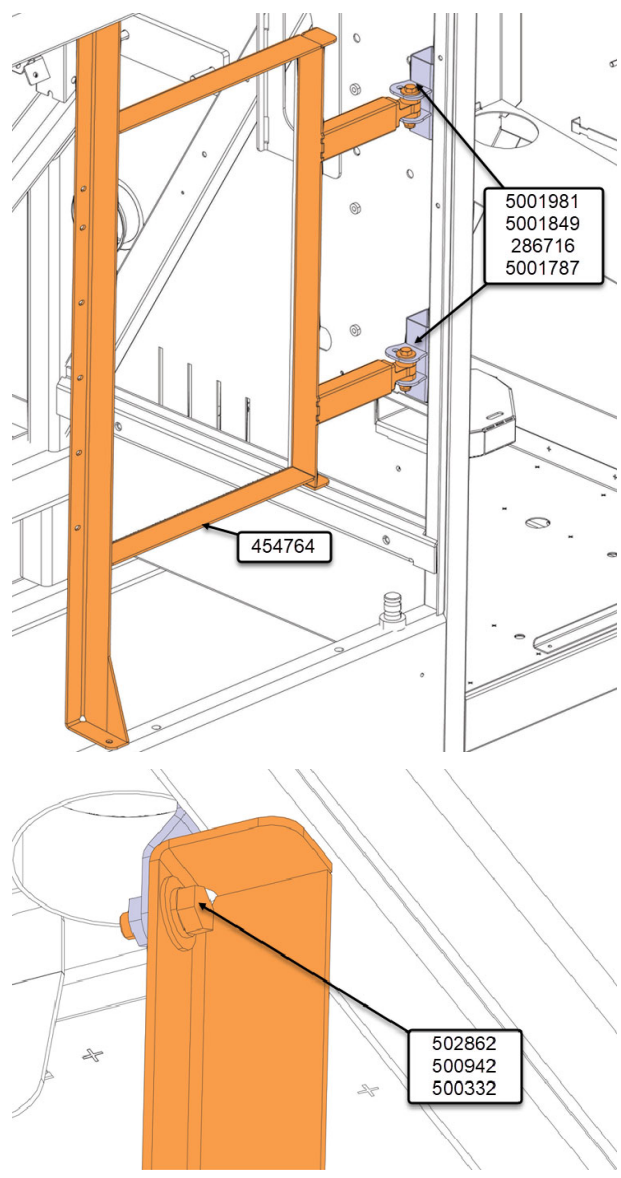

8. Weld the brackets 2810648 (2X), see the images.

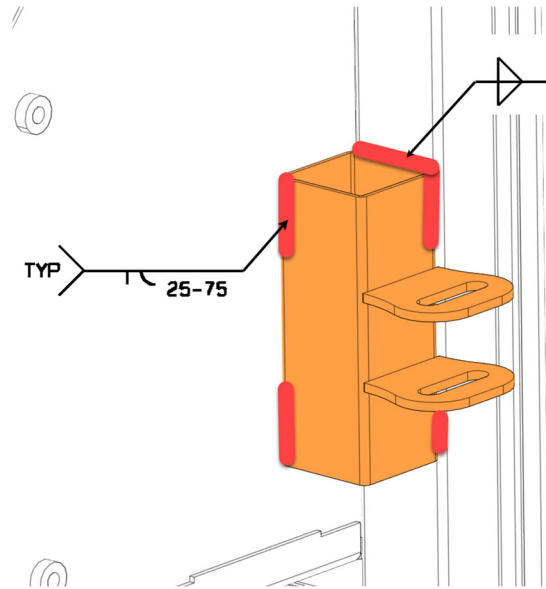
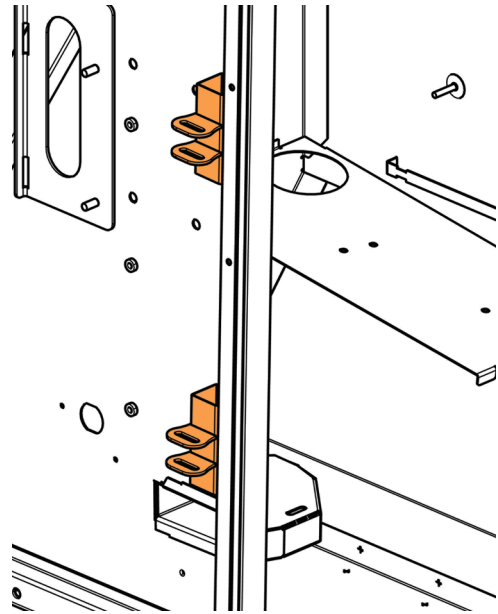

9. Weld the bracket 218982, see the image.

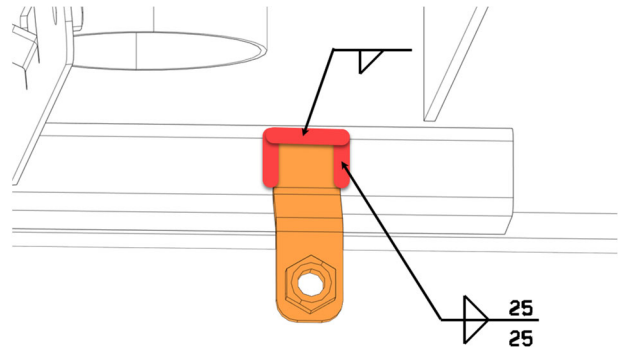

10. Weld the nut 502609 on two faces, see the image.

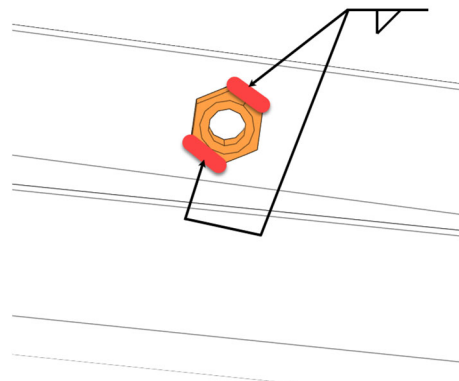

**Vehicle with reinforcement for the rear right slide-out**

1. Assemble the bracket 2810648 (lower) and the bracket 2810658 (upper) to the condenser support assembly 454764 with the bolts 5001981 (2x), the washers 5001849 (4x), the spacers 286716 (4x) and the nuts 5001787 (2x).
2. Assemble the angular 218942 to the condenser support assembly 454764 with the bolt 502862, the lock washer 500942, the washer 500332.

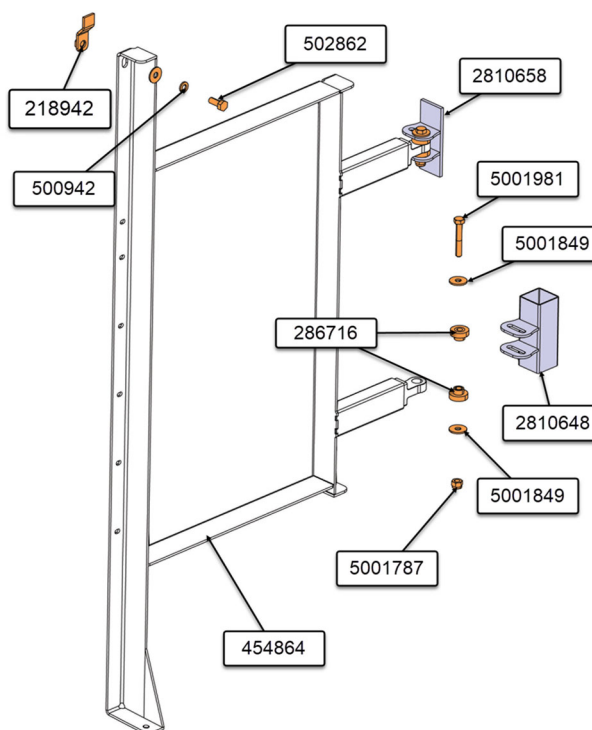

11. Secure the assembly with clamps.

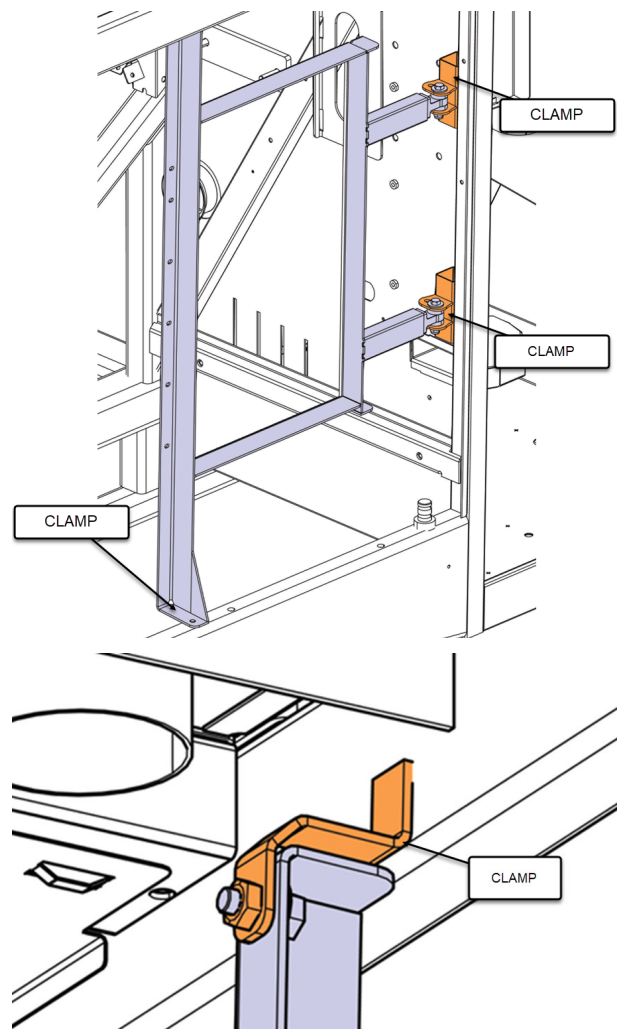

12. Tack weld brackets 2810648 and 2810658 and the angular 218942 to the structure.

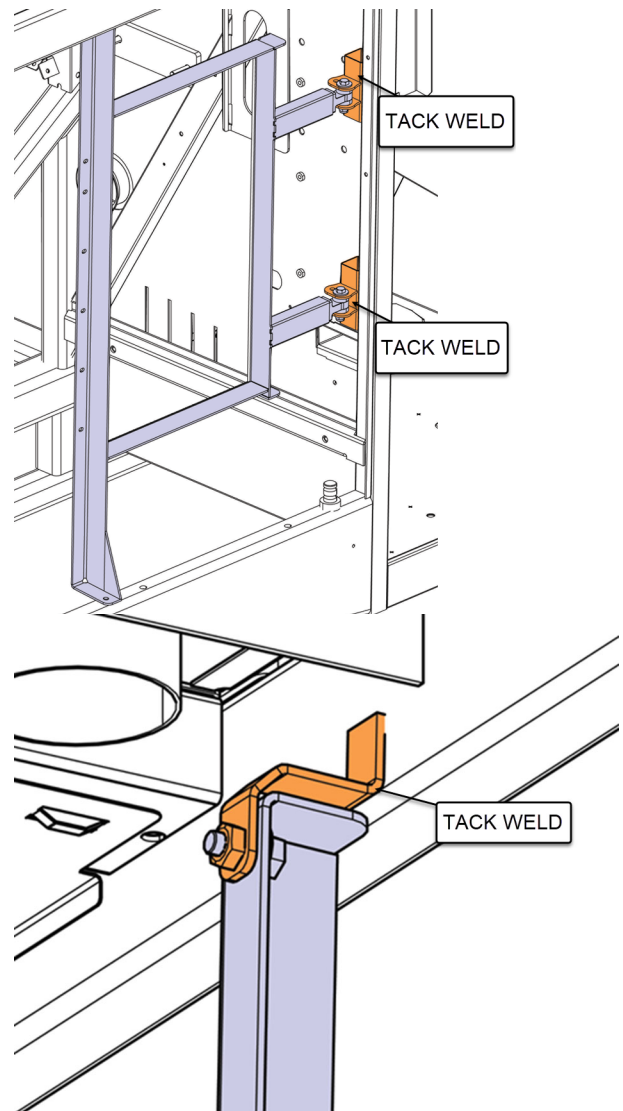

13. Drill 7/16"Ø hole using the frame as a guide.

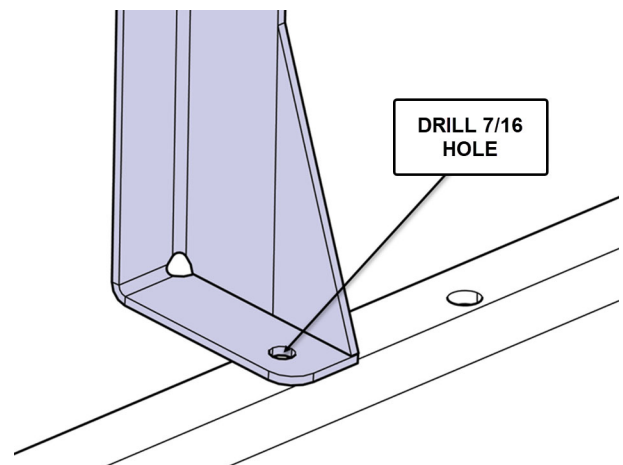

14. Remove the bolts 5001981 (2x), the washers 5001849 (4x), the spacers 286716 (4x), the nuts 5001787 (2x) and the condenser support assembly 454764.
15. Remove the bolt 502862, the lock washer 500942 and the washer 500332 that secure the top of condenser support assembly 454764.

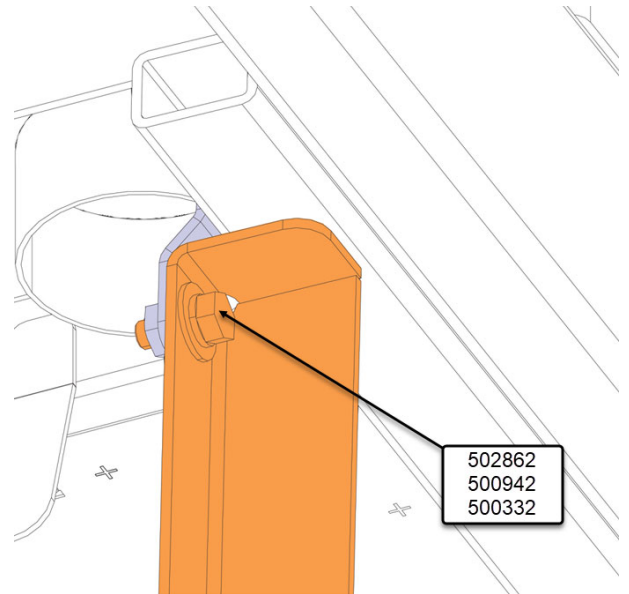
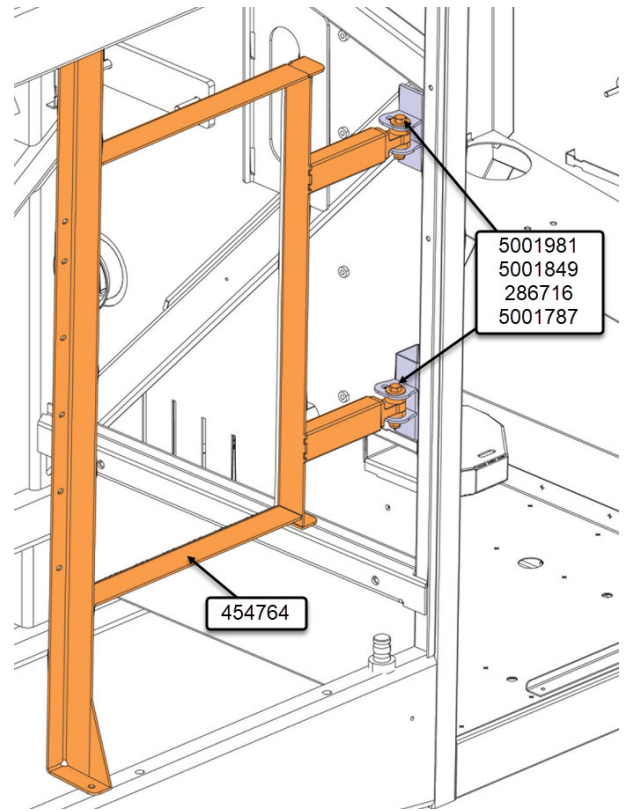



16. Weld the brackets 2810658 and 2810648, see the images.

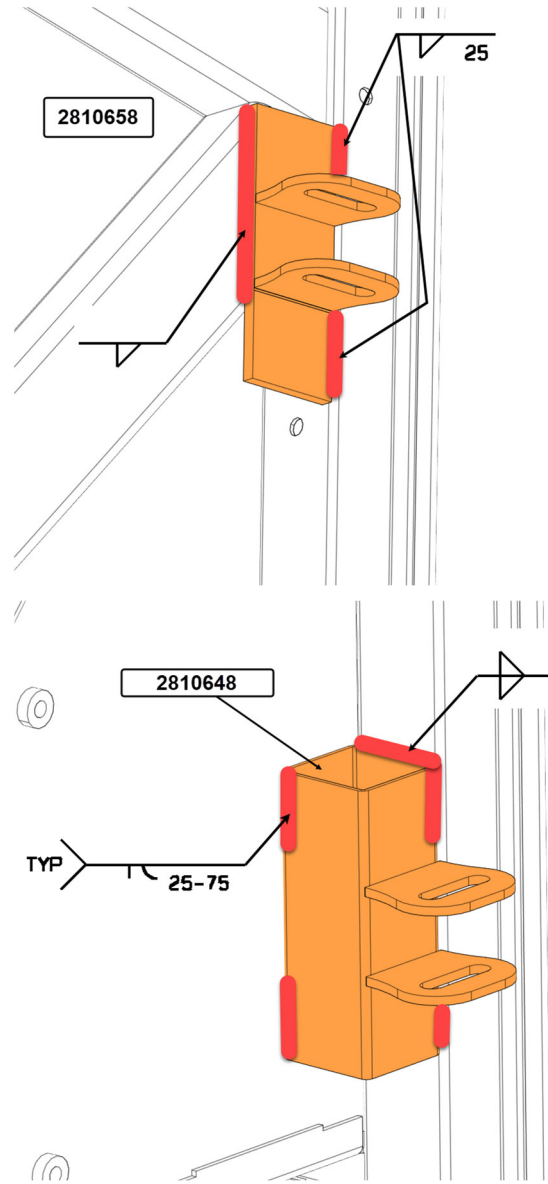

17. Weld the bracket 218982, see the image.

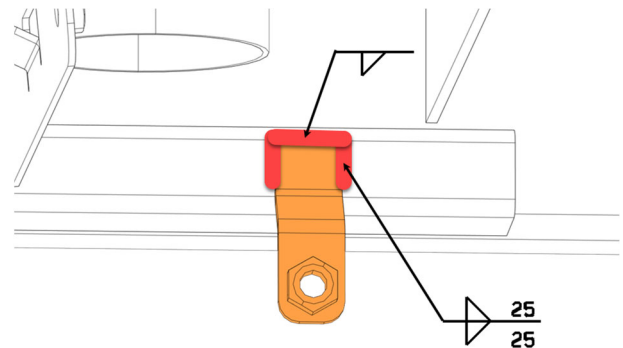

18. Weld the nut 502609 on two faces, see the image.

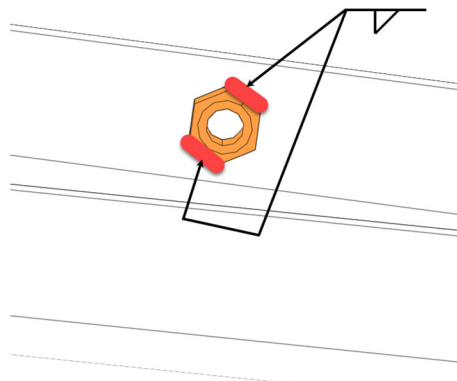

**Weld section Air Filter and Air Dryer**

19. Check that the air filter support does not interfere.

- If yes, go to step 20
- If no, go to step 21

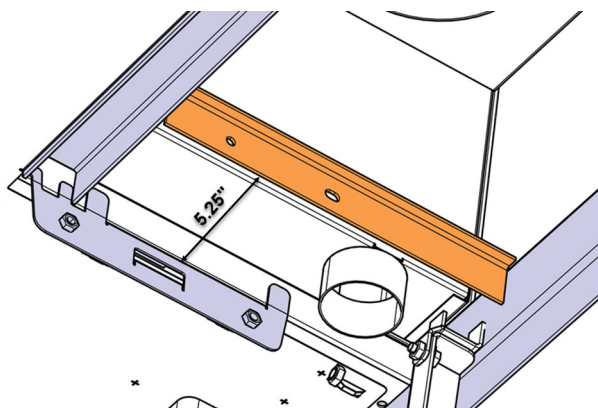

20. If the air filter support interferes. Cut according to the marking on the support.

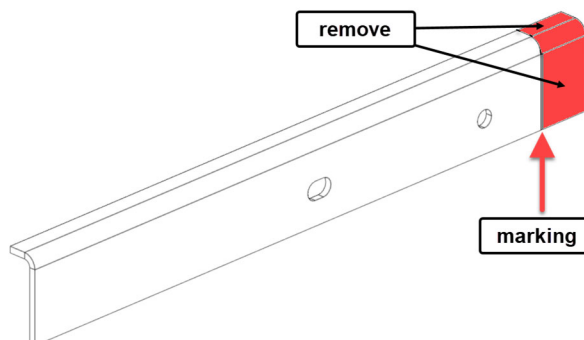

21. Weld the air filter bracket 218944 full at both ends, see the image.

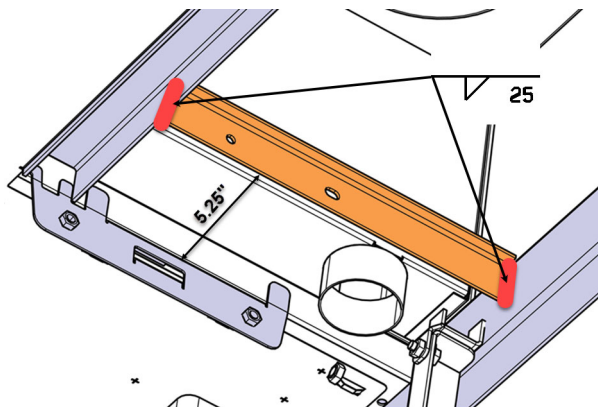

22. Assemble the air intake bracket 218943 to the top bracket 454892 with the washer 500332 and the nut 5001931.
23. Assemble the top bracket 454892 to the air dryer bracket 454888 with the washers 500332 (2x) and the nuts 5001931 (2x).
24. Assemble bracket 454893 to the air dryer bracket 454888 with the bolts 502780 (2x) and the washers 5001868 (2x).
25. Assemble lower bracket 218948 to the air dryer bracket 454888 with the washers 500332 (2x) and nuts 5001931 (2x).

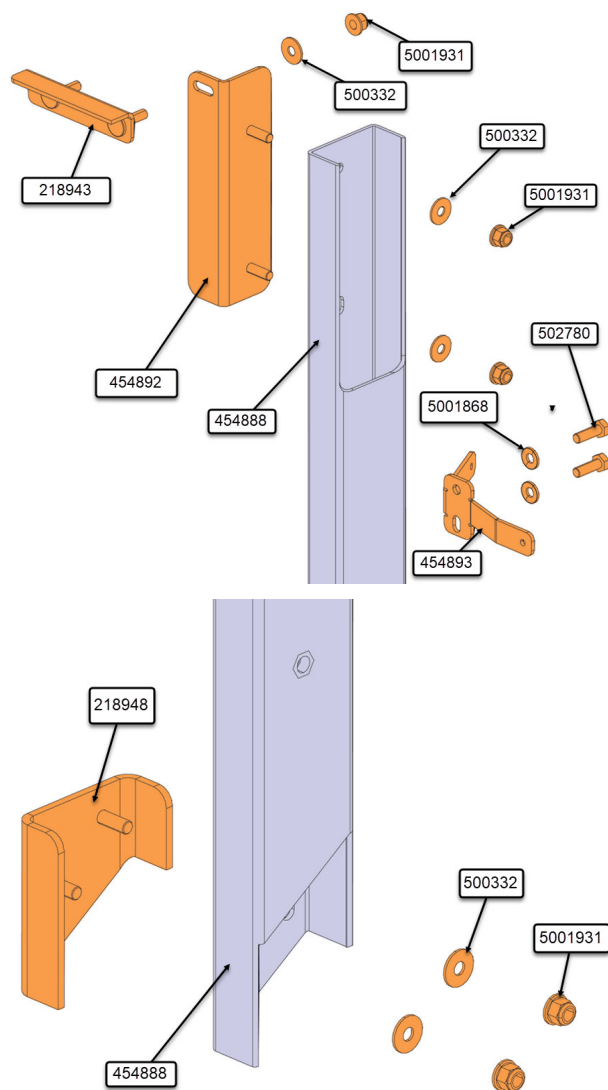

26. Tack weld lower section of the assembly.

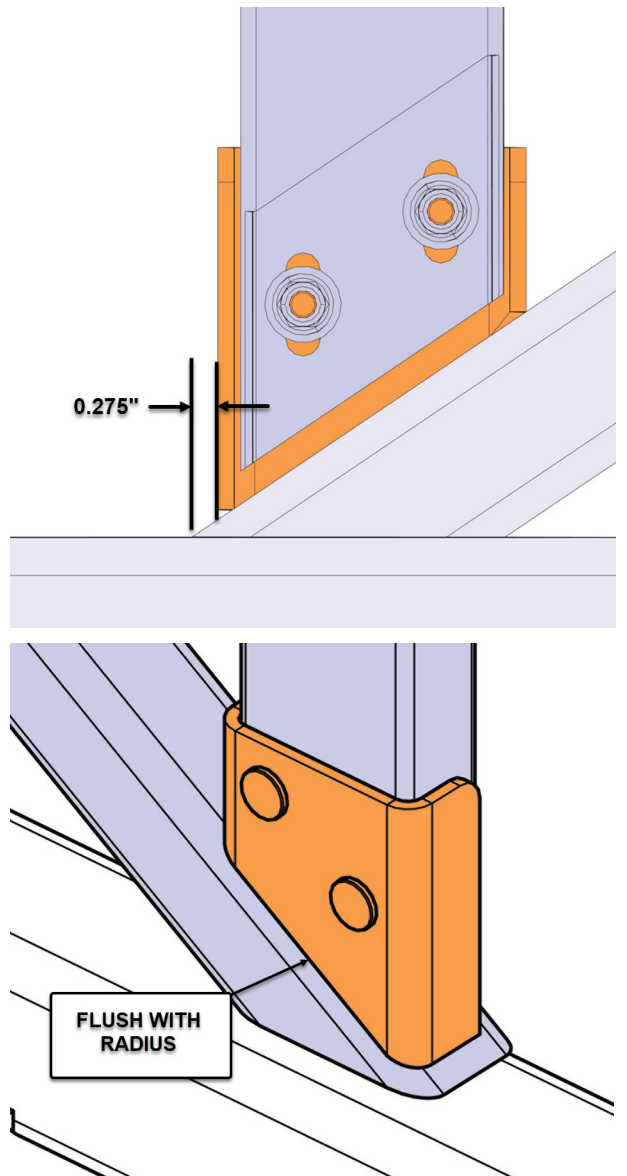

27. Tack weld lower section of the assembly.

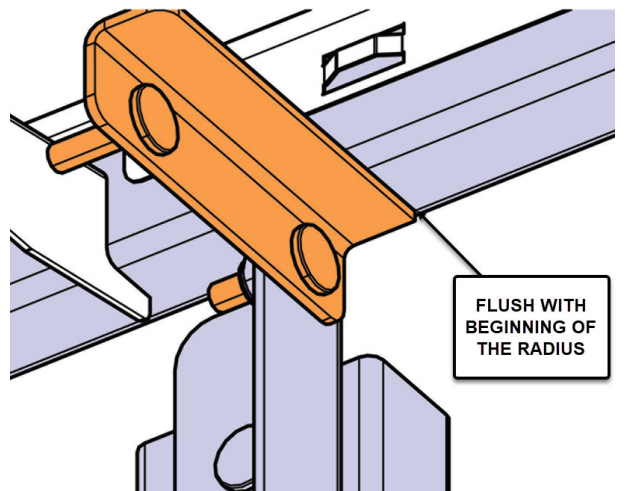

28. Remove the assembly, the nuts 5001931 (3x) and the washers 500332 (3x).

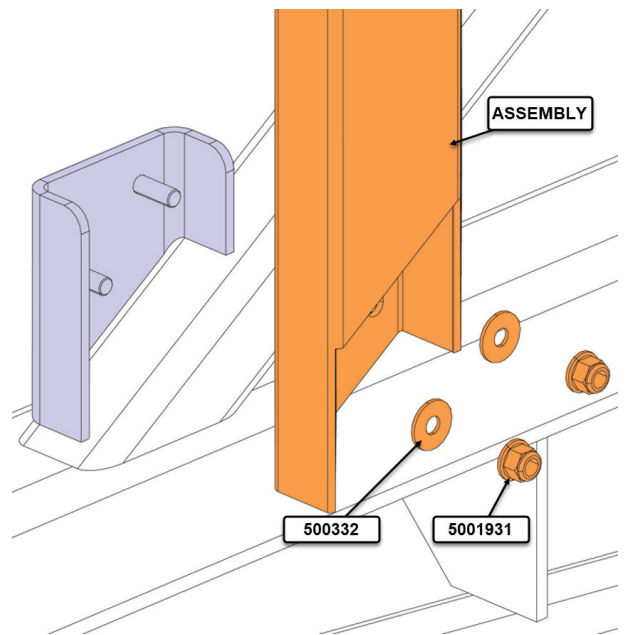
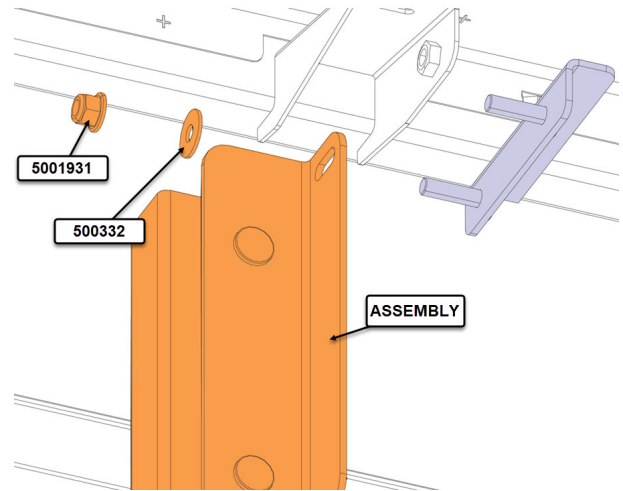

29. Weld the lower bracket 281948 full inside and outside, see the images.

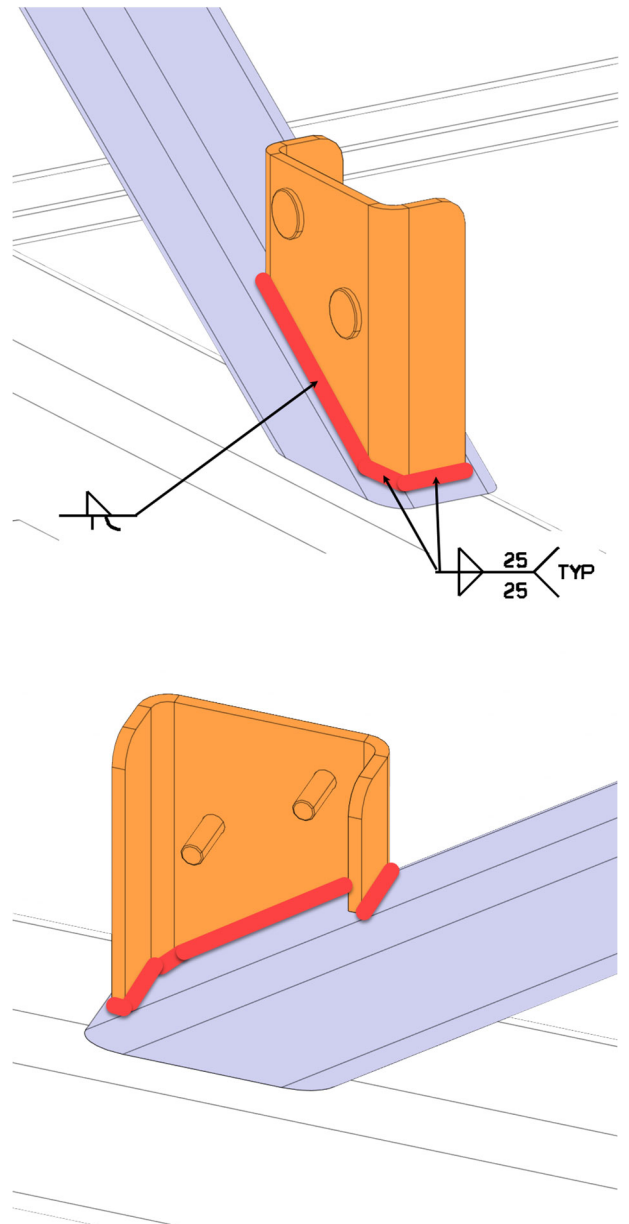

30. Weld the intake bracket 281943, see the image.

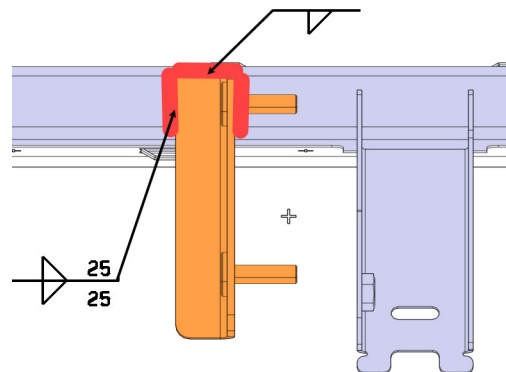

**Only vehicle with slide-out reinforcement**

31. Weld the new oil tank bracket 218949, see the image.

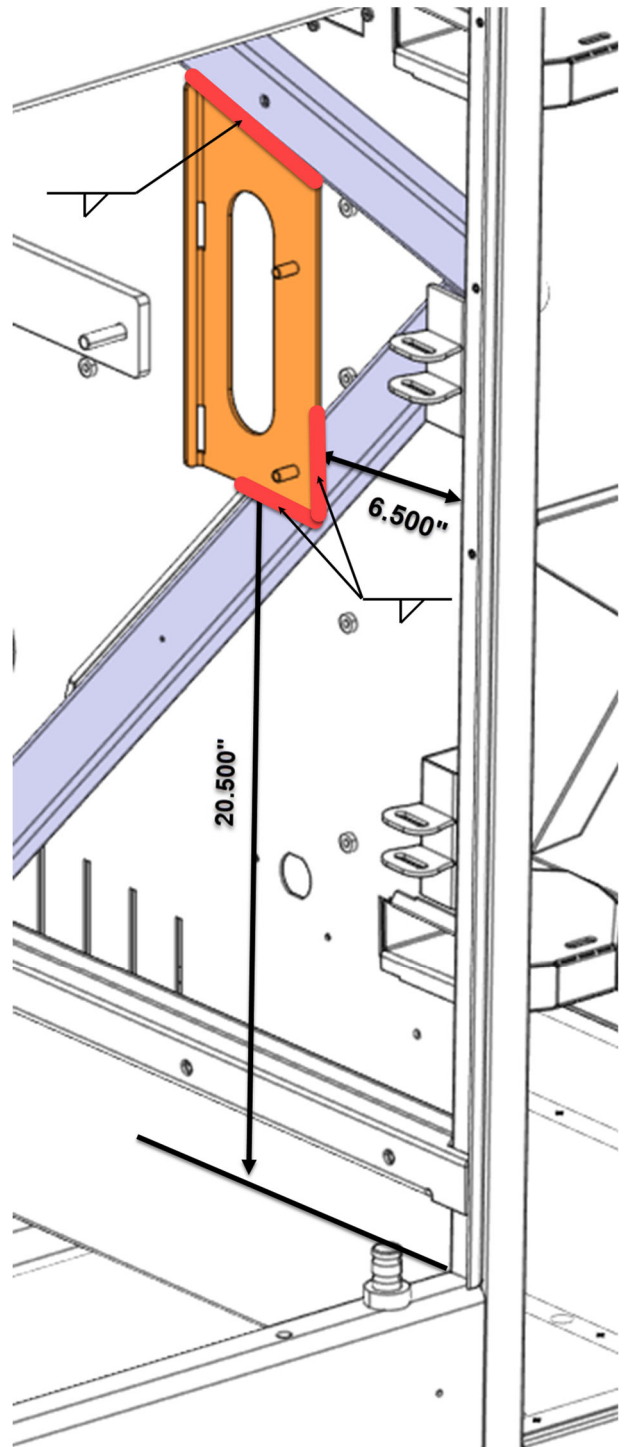

## C. AIR FILTER INSTALLATION

1. Install the assembly with the nuts 5001931 (3x) and the washers 500332 (3x).

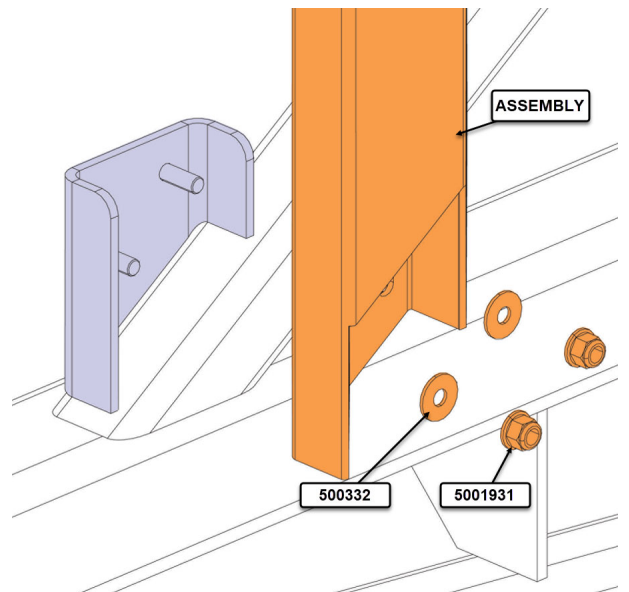
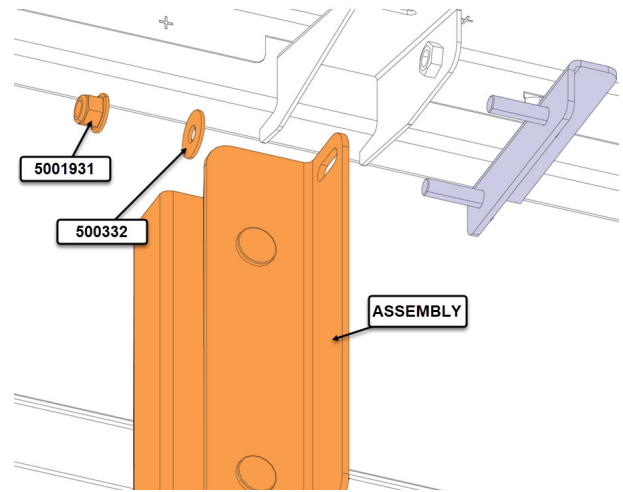

2. Drill 2 holes  $3/8"$ Ø for the installation of the rear air filter bracket 030292.

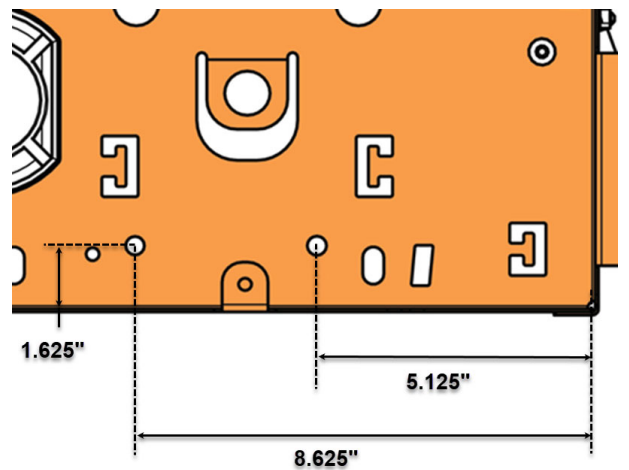



3. If your vehicle is built before GHG 2017, you need to install this adapter 030232.
4. Clamp the adapter and drill 3 holes with drill size #40.
5. Secure the adapter 030232 with the rivets 504339 (3x).

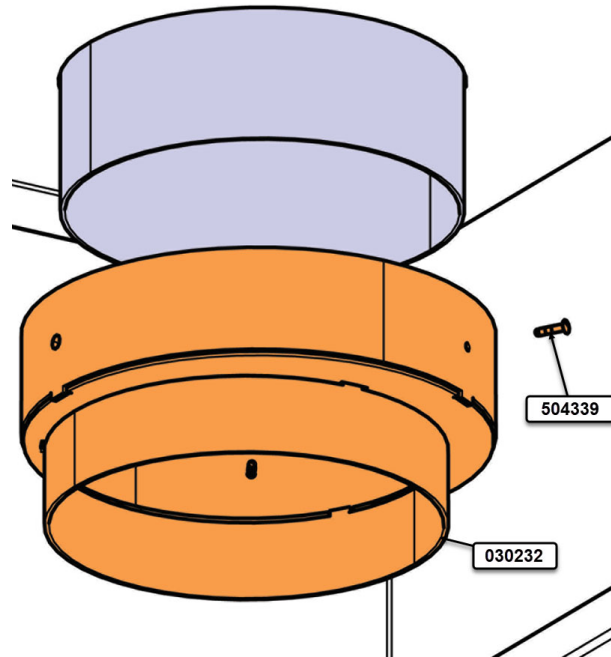

6. Install the front air filter bracket 030293 with the bolts 502862 (2x), the washers 500332 (2x) and the nuts 502692 (2x).

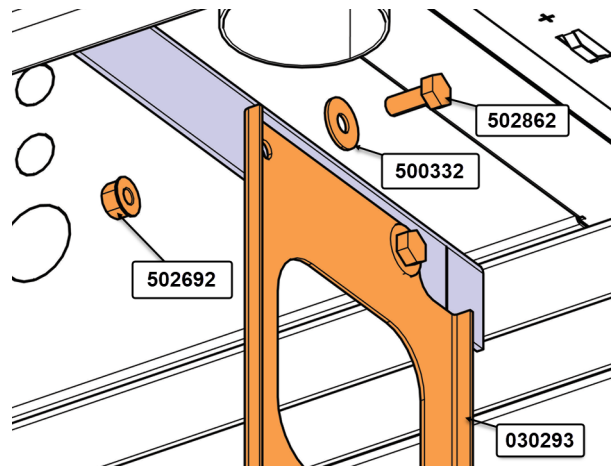

7. Install the rear air filter bracket 030292 with the bolts 502862 (2x), the washers 500332 (2x) and the nuts 502692 (2x).

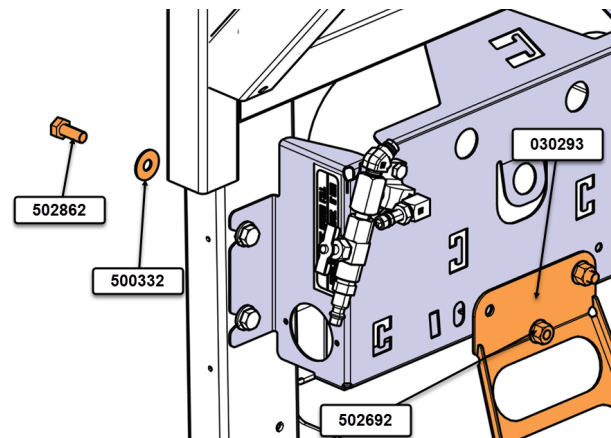

8. Fasten together the air filter brackets 030292 and 030293 with the bolts 502862 (2x), the lock washers 500942 (2x) and the washers 5001736 (2x).

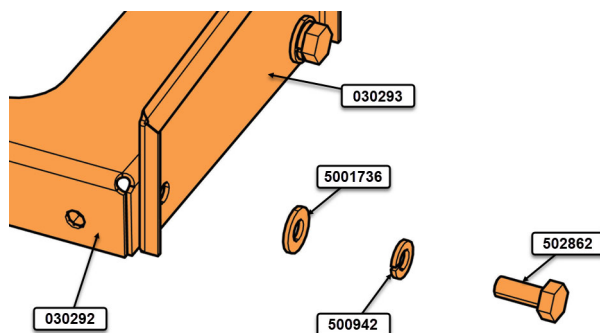

9. Remove bolts securing cover of air filter 531493 and discard  
10. Replace it with the new bolts 5001990 (4x) and the new washers 5001736 (4x).

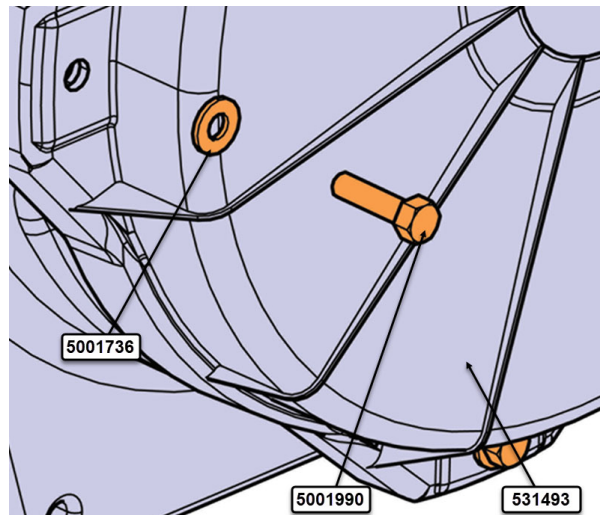

11. Install the air filter 531493 on the rear air filter bracket with the bolts 502836 (4x), the lock washers 500942 (4x) and the washers 5001736 (4x).

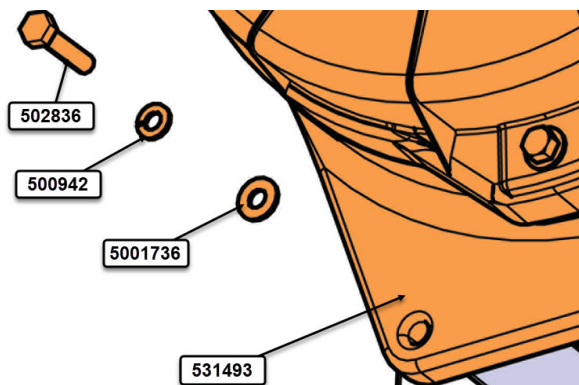

12. Install hose 030286 between vehicle air intake and air filter with the clamps 504229 (2x).

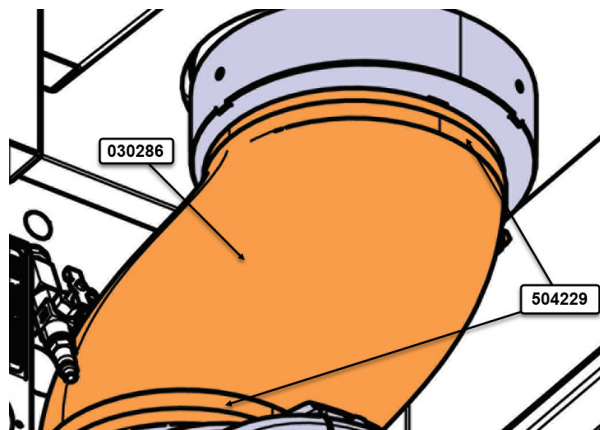

13. Install the reducer 531363 on the air filter 531493 with the clamp 504229.

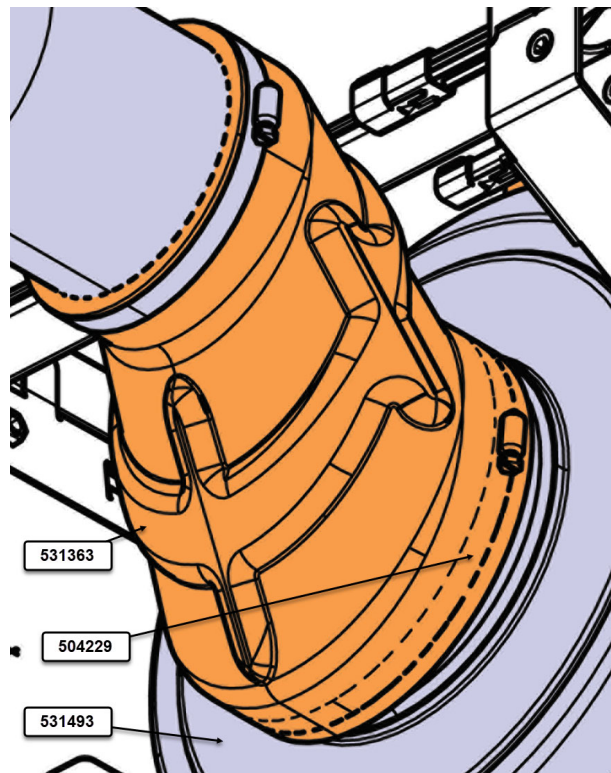

14. Re-install the inlet hose 21659720 with the clamp 504257.

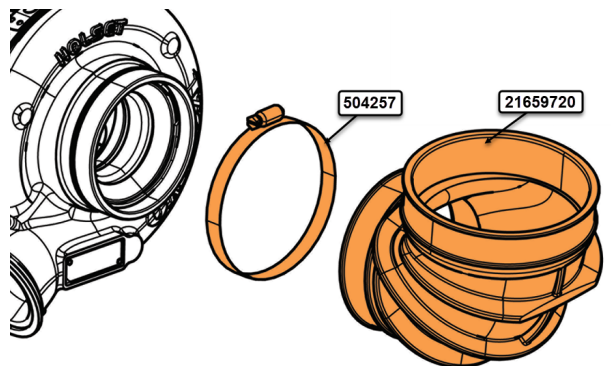

15. Install the air pipe 030053 on the reducer 531363 with the clamp 504324.

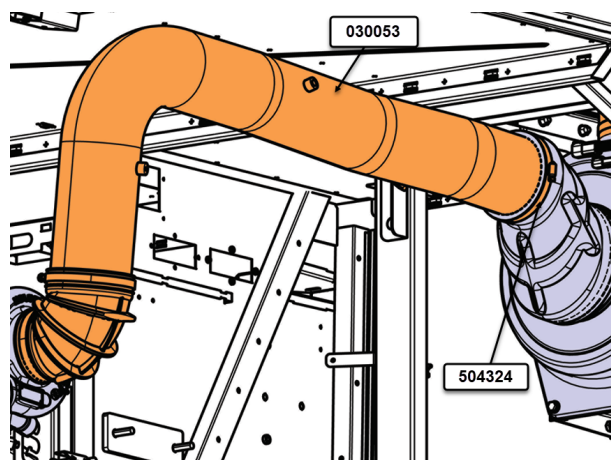

16. Install the air pipe 030053 on the inlet hose 21659720 reinstall clamp 504324.

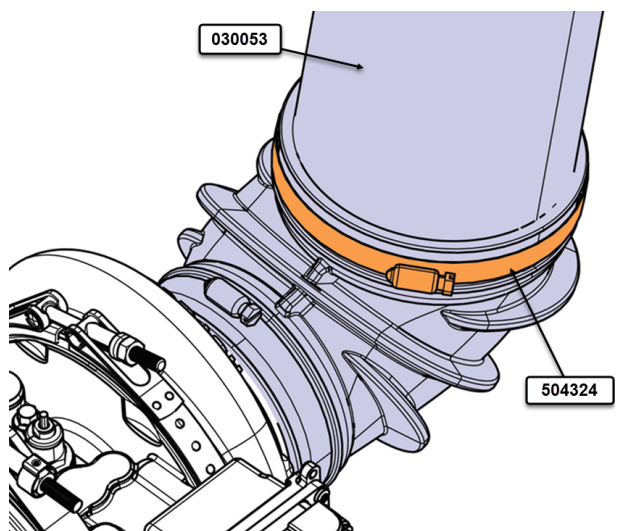

17. Install the bracket 032541 on the pipe 030053 with the spacer 032540, the washer 500332 and the nut 5001931.

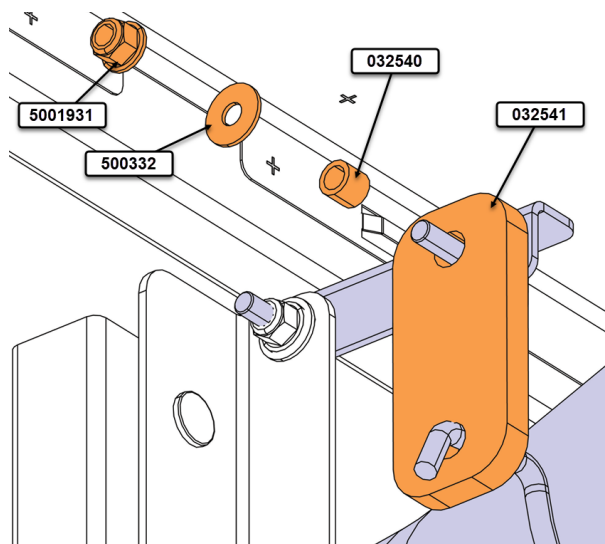

18. Re-install the filter restriction indicator 530161.

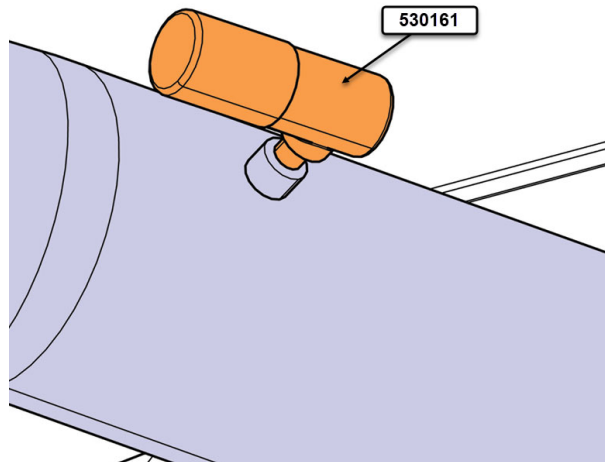

19. Install the hose 030291 between the pipe 030053 and the air compressor with the adapter 5011240 and the clamps 504291 (2x).

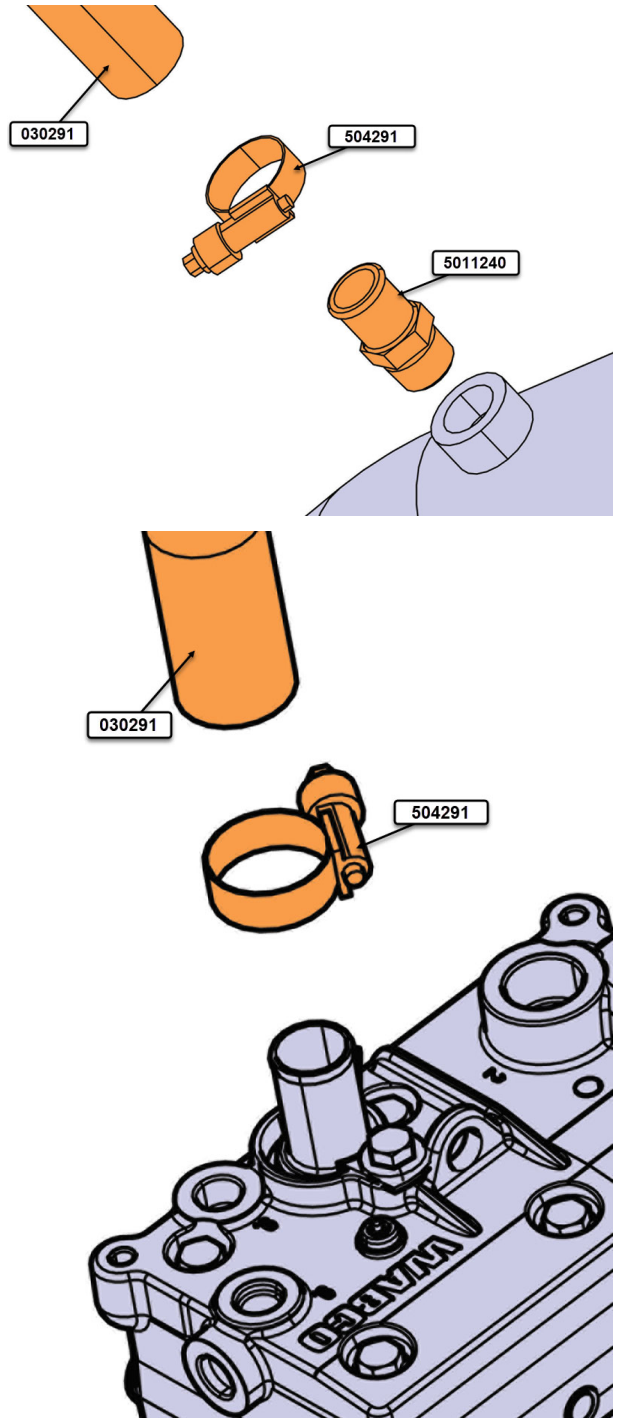

20. Install the decals 030045, 030046, 034005.

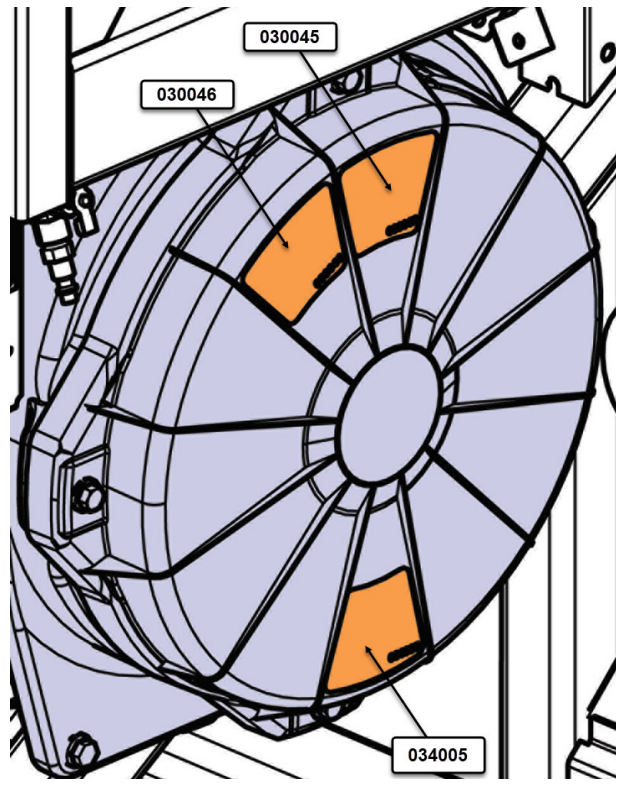

## D. COMPRESSOR DOOR MODIFICATION

1. Install the rubber plugs 504709 (2x) on the panel 2810653.

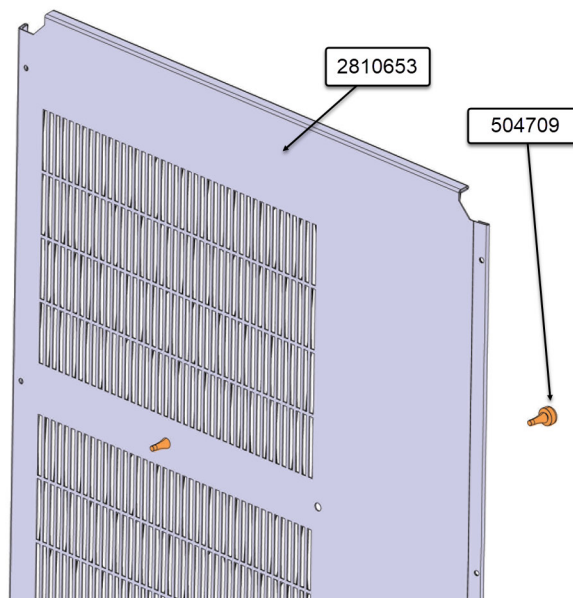

2. Install panel 2810653 on the compressor door with the screws 509805 (6x).

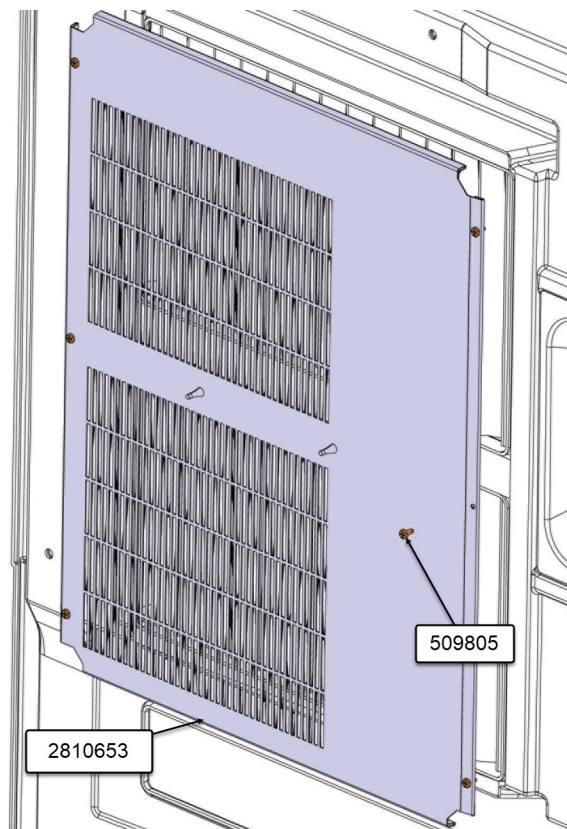

## E. CONDENSER INSTALLATION

1. Install the tape 506228 (6.5 ft) on condenser support assembly 454864.
2. Secure the condenser 950552 on the condenser support 454864 with the screws 500283 (12x).

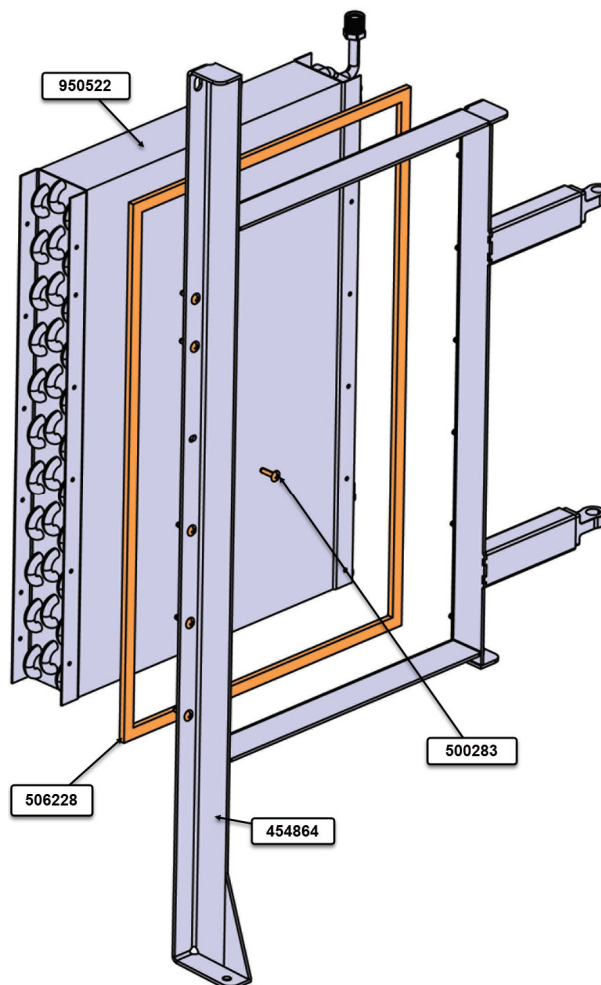



3. Install the rubber strip 506302 (7 ft) on condenser support assembly 454864.

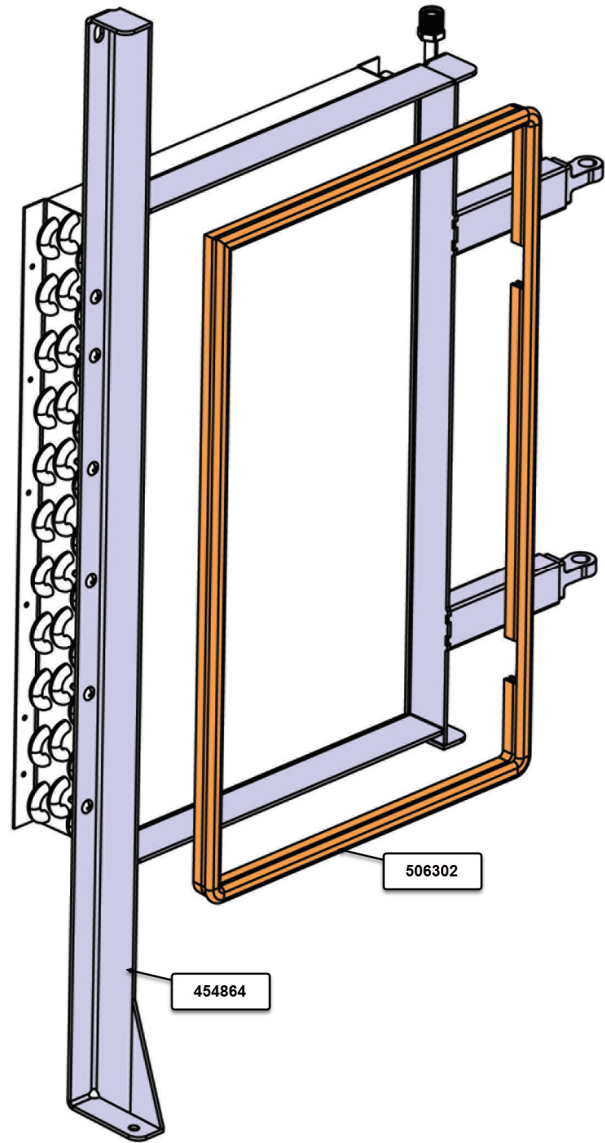

4. Install the shroud 454037 on the condenser 950552 with the screws 5001975 (14x) and the washers 5001137 (14x).
5. Install the clamps 952629 (3x).
6. Install the cable tie mounts 504013 (2x) with the rivets 504379 (2x).

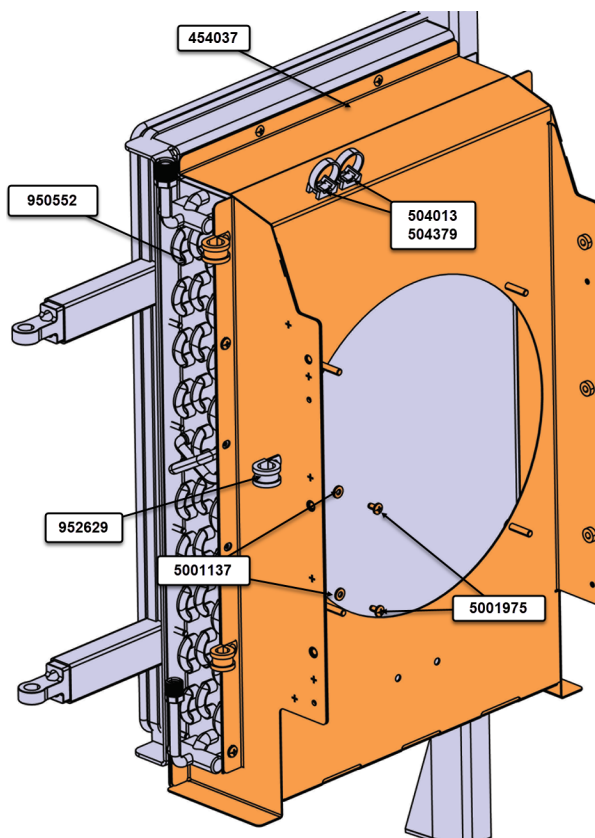

7. Install the fan 565881 on the shroud 454037 with the nuts 5001851 (4x) and the washers 5001833 (4x).
8. Install the fir tree mounting 509815 (2x).

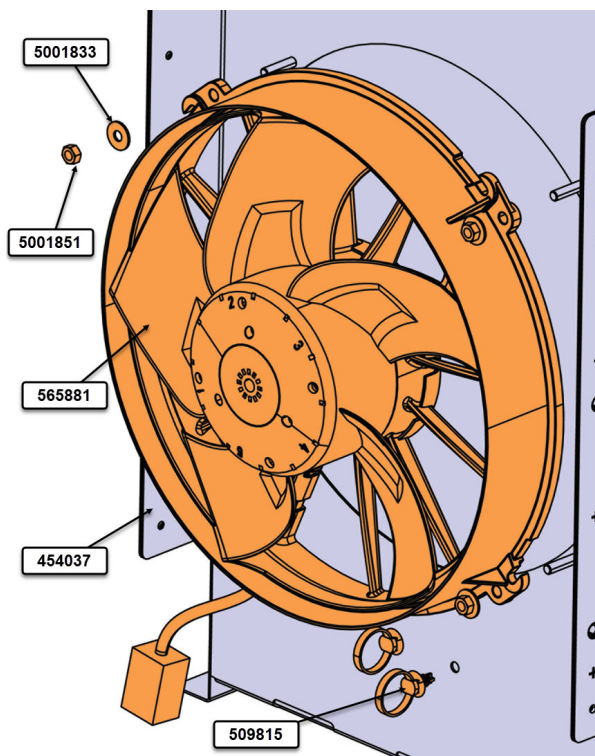

9. Install the protective panel 454036 on the shroud with bolts 5001697 (6x), the lock washers 502853 (6x) & the flat washers 500411 (6x).

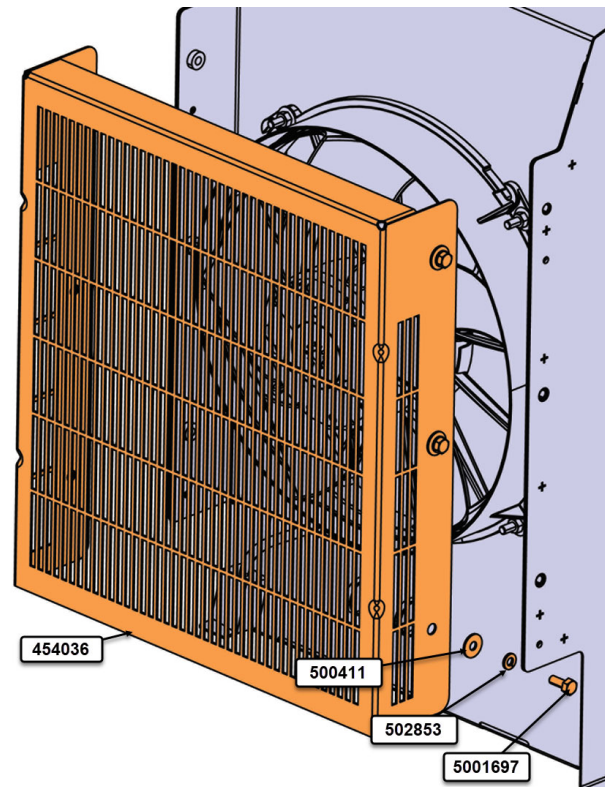

10. Install the right side of the condenser assembly on the vehicle with the bolts 5001981 (2x), the washers 5001849 (4x), the spacers 286716 (4x) and the nuts 5001787 (2x).

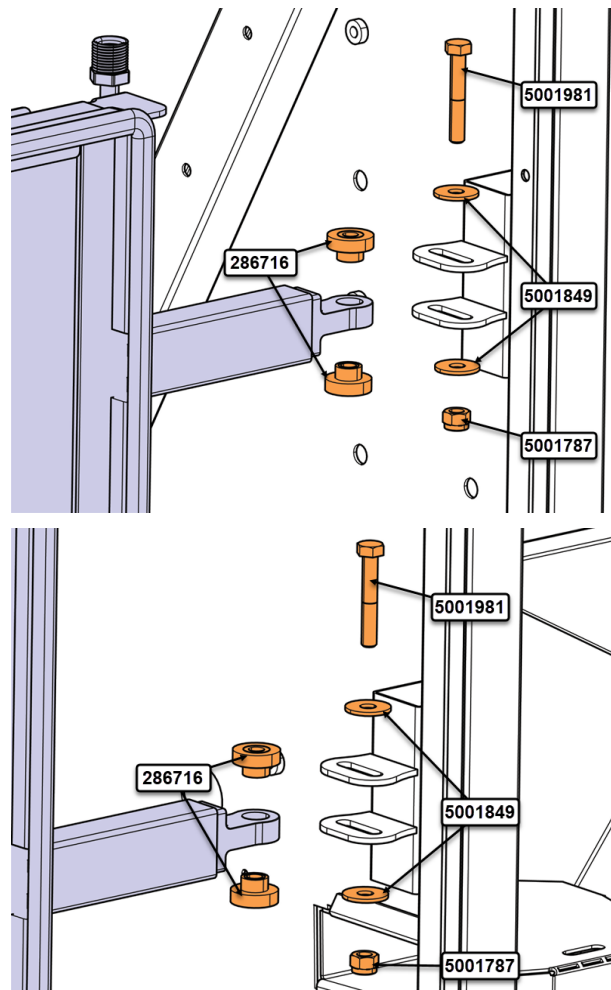

11. Install the left side of the condenser assembly on the vehicle with the bolts 502862 (2x), the lock washers 500942 (2x), the flat washer 500332 (2x).

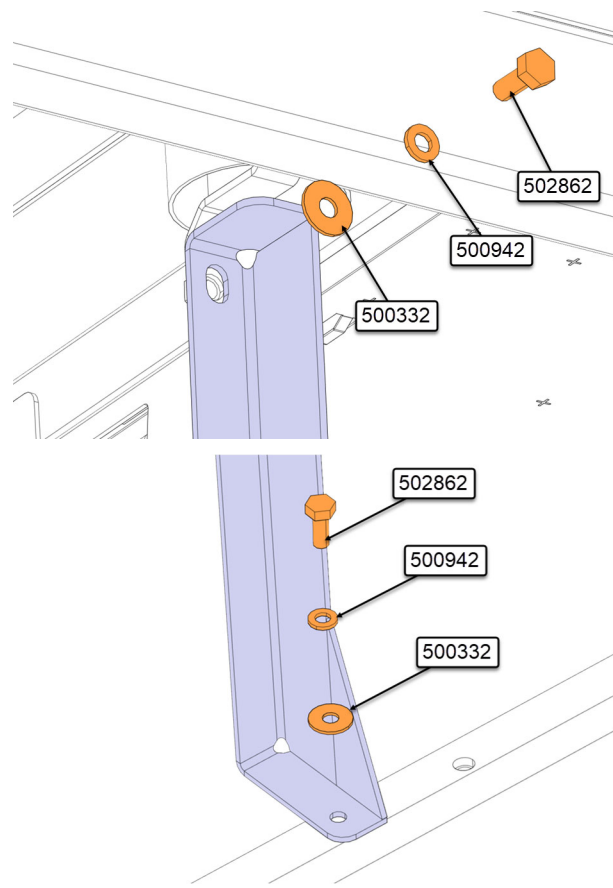

## F. DRYER INSTALLATION

1. Assemble the pressure switch 950270 with the connector 561566, the wire seals 561565 (2x) and the terminals 561567 (2x).

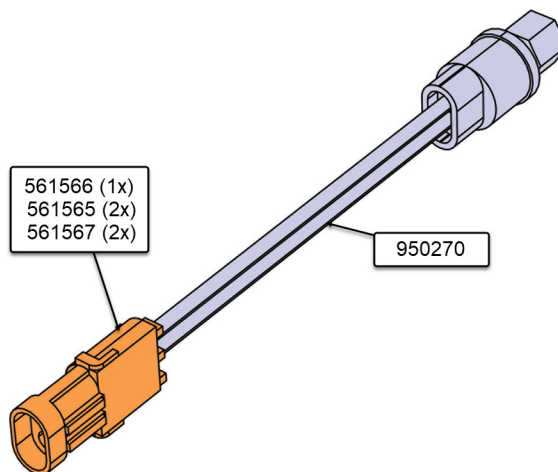

2. Uninstall the pressure transducer 563423 and the valve 950249.

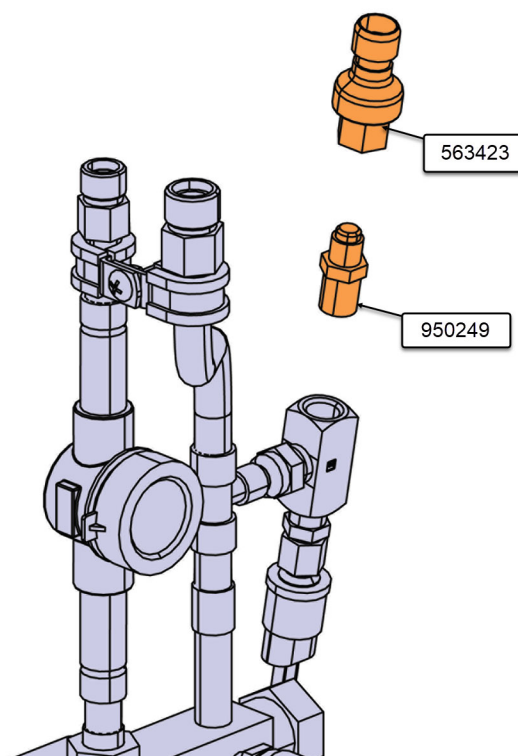

3. Modified the dryer assembly, add the adapter 501338, the valve 950249 and the new pressure switch assembly 950270. Reinstall the pressure transducer 563423 and the valve 950249.

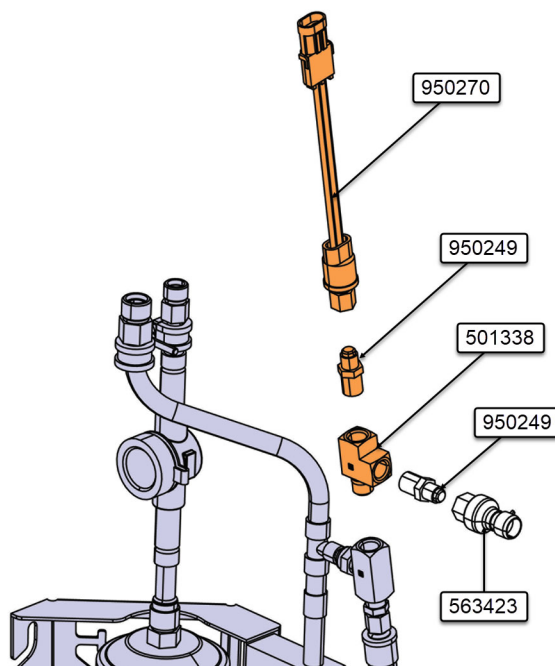

4. Secure the dryer assembly on the vertical post with the bolts 502780 (2x) and the washers 5001868 (2x).
5. Install the clamp 952629 with the bolt 500266.

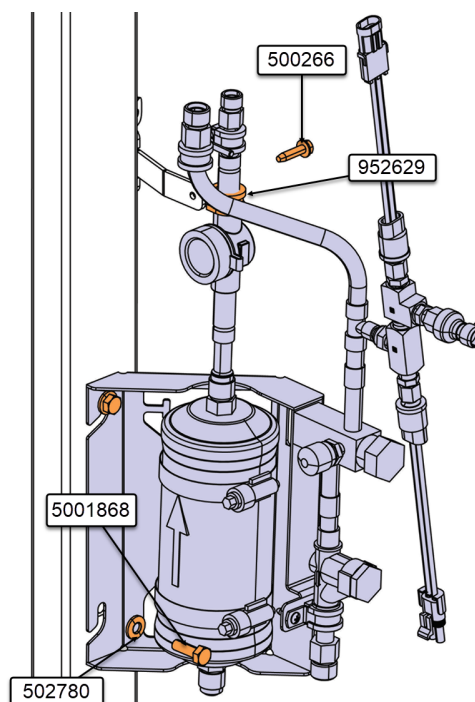

## G. HOSES INSTALLATION

Hoses overview:

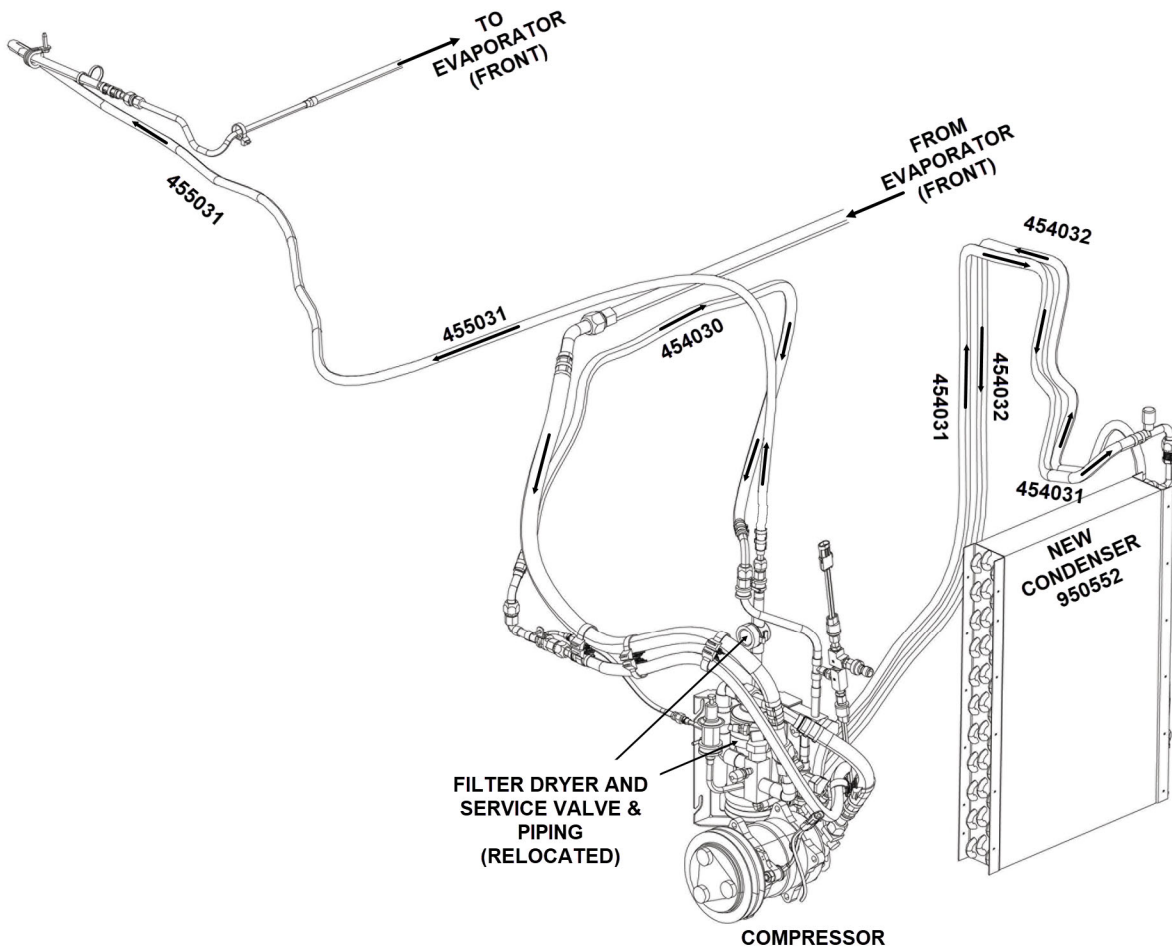

1. Connect the hose 454030.

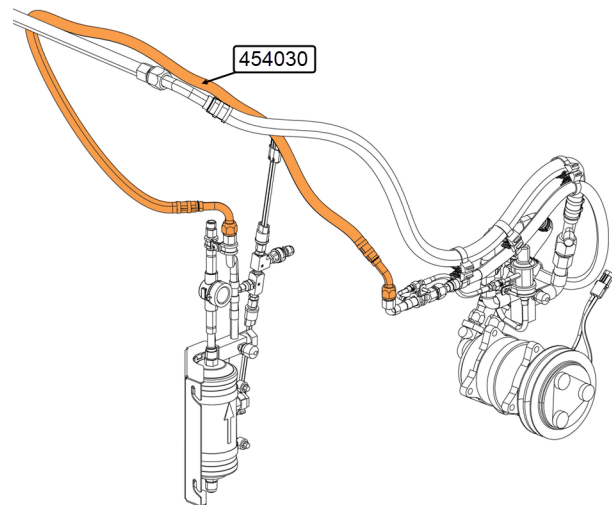

2. Connect the hose 454031.

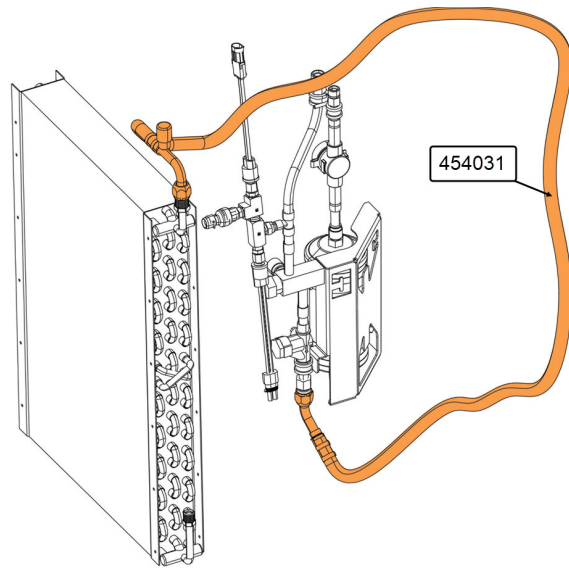

3. Connect the hose 454032.

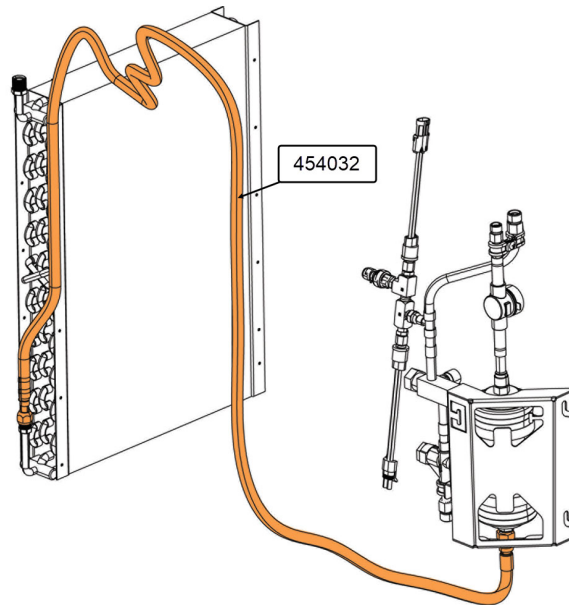

4. Connect the hose 455031.

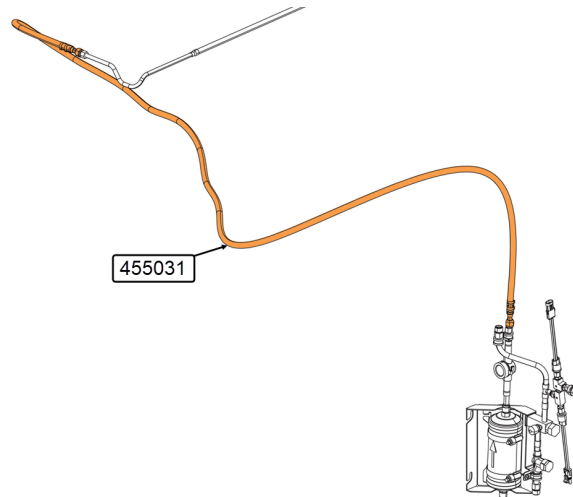



## H. HOSES FASTENING

Overview of hoses fastening:

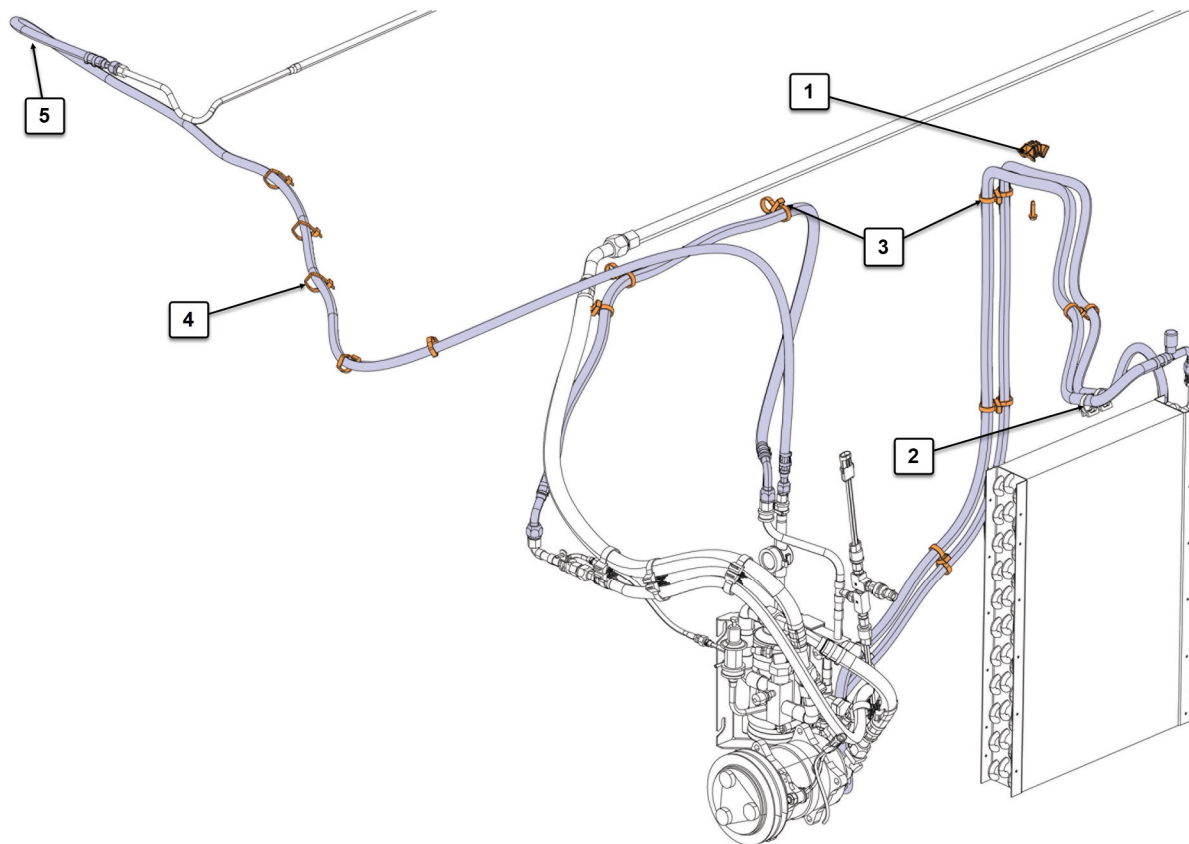

### CAUTION

Never attach any hose to harness

1. Secure the hoses 454031 and 454032 to the top of the compressor compartment with the two-way saddle mounts 509490 with the bolt 500266.
2. Attach hoses 454031 and 454032 with cable ties 504016 (2x).

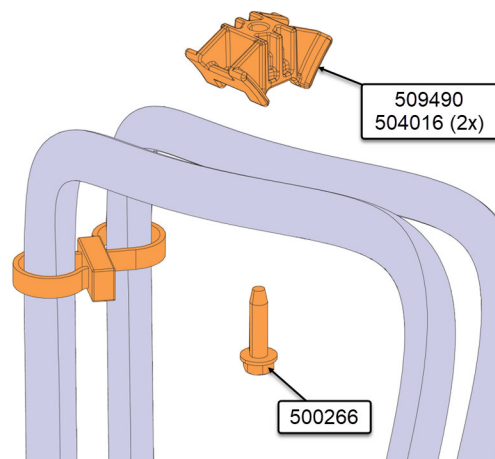

3. Secure the hoses 454031 and 454032 to the condenser assembly with the cable tie 504016 and the clamps 952629 (2x).

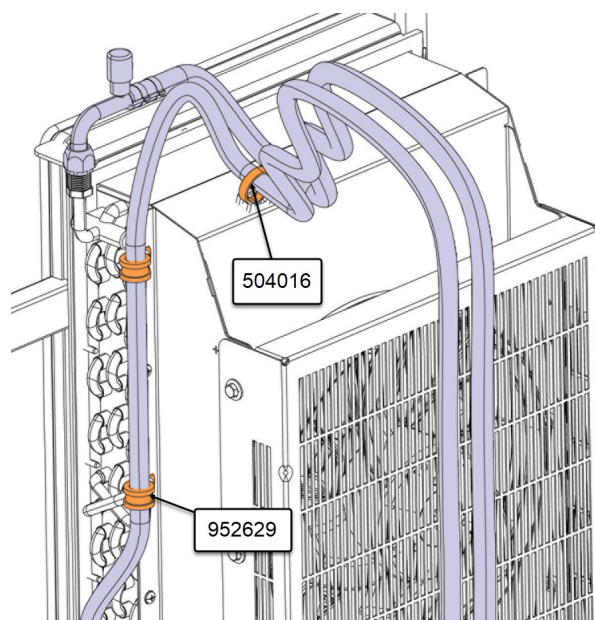

4. Secure all new hoses with the double loop cable ties 504768 (15x).

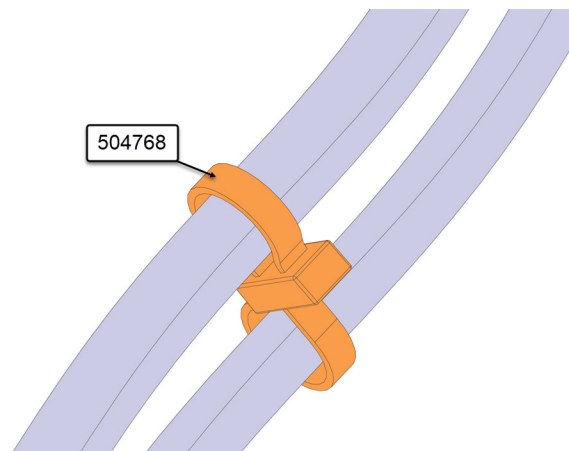

5. Secure the hose 455031 with the cable ties 504016 (10x) using the same routing of the older hose.

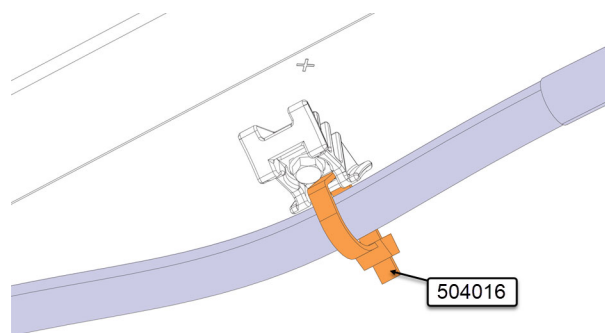

- Secure the hose 455031 with the clamp 952631 with the bolt 500266.

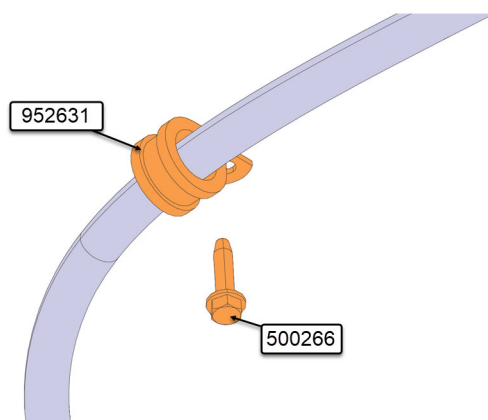

- Refill refrigerant liquid.

## I. POWER STEERING TANK INSTALLATION

**Vehicle with reinforcement for the rear right slide-out**

1. Reinstall the tank with the nuts 502837 (2x).

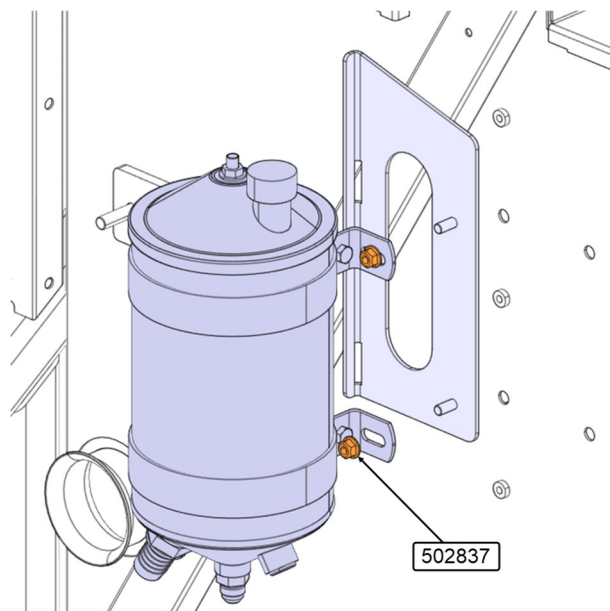

2. Reconnect the two power steering hoses.

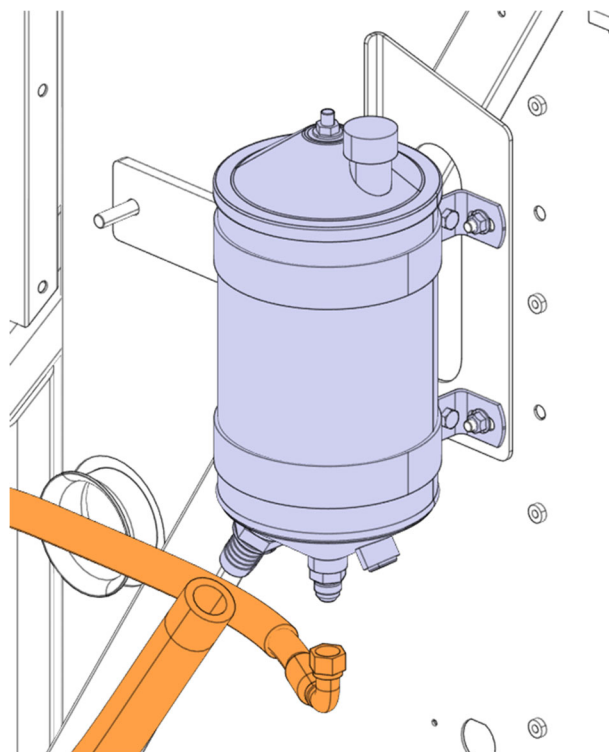

3. Refill the tank with recommended oil.

# J. WIRING HARNESS INSTALLATION

Wiring schematic

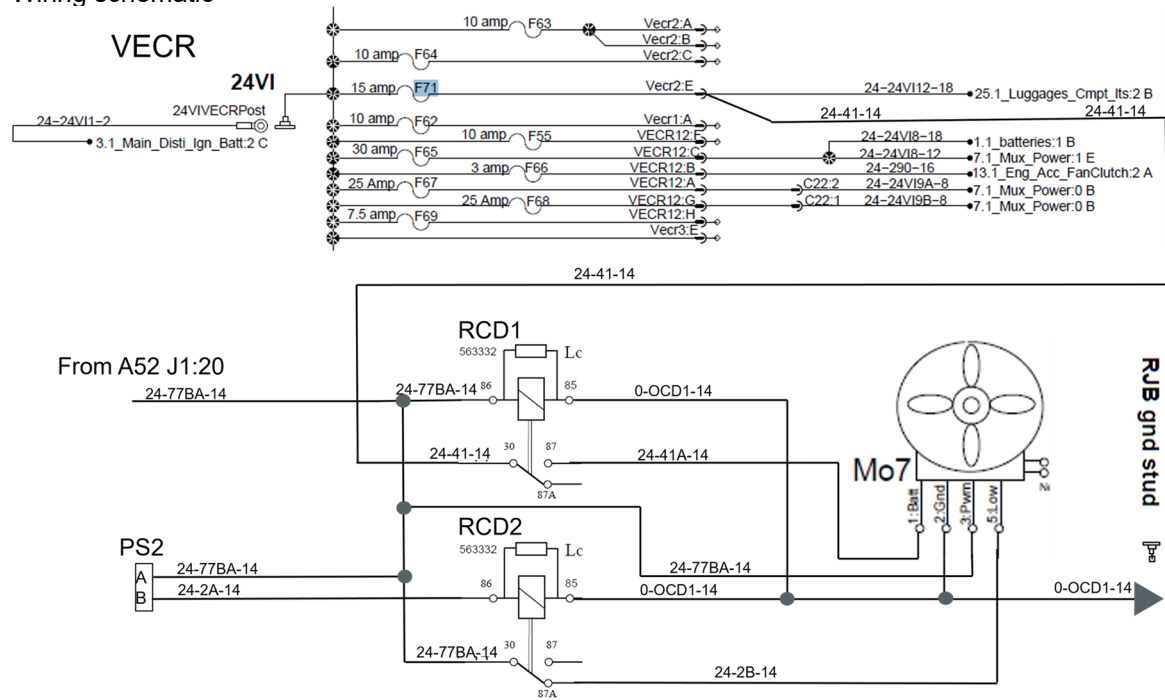

1. Install harness 0610379 with the cable ties 504637 (30x).
2. Secure the relay base with the screw 502868 (2x).
3. Install the relays 563332 (2x).

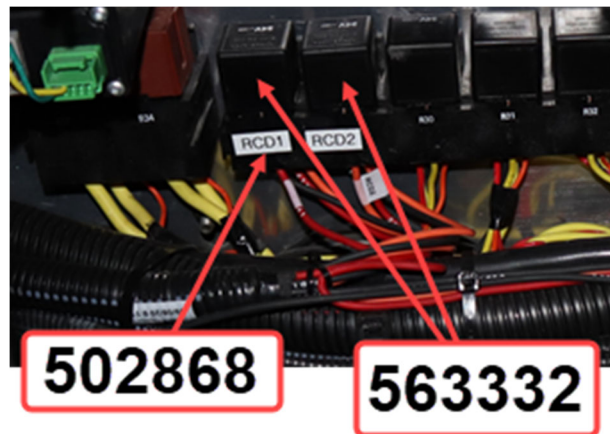

4. Secure the ground **OC1** to ground stud (beside the start relay).



5. Splice wire **77AB** with wire at **A52 J1:20**.



6. Crimp together wire **41** (the lamp wire and the harness 0610379) with the terminal 562101.



7. Plug fan condenser **Mo7**.  
8. Use the cable tie 504637 (2x) to fix the connector to the fan shroud.



9. Connect **PS2** to pressure switch 950270.

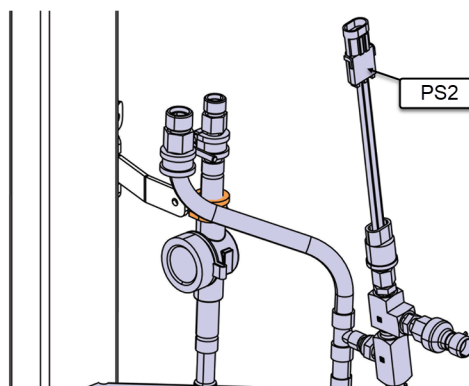

## K. VPG: PARAMETER SETTING

Vehicle ID#:   **Messages: \*\*\* Other version of programs available \*\*\***  
**RECOMMENDATION: Generate and Transfer the Multiplex program!**  
 Vehicle generic program has changed since last generation!

General | Vehicle Parameters | Program Generation | Transfer to the Vehicle | Vehicle History |

**Vehicle Info**

|                   |                   |                  |             |                      |       |
|-------------------|-------------------|------------------|-------------|----------------------|-------|
| VIN #:            | 2PCC33494FC735807 | Vehicle Type:    | MTH XL2 45E | MID 188              | SW ID |
| Sales Order:      | 0004046183 000010 | Statut:          | In Service  | 70403450P02*06100061 |       |
| Production Order: | 000007017979      | Production Date: | 2014/10/24  | P43*00155807A14*     |       |

**Software ID as shown in the Vehicle MCD**

**Vehicle Events Data**

|               | Current Data                | Last Generation               | Last Transfer                 |
|---------------|-----------------------------|-------------------------------|-------------------------------|
| User name:    | Jean Ruel (Service Rep.)    | MLO Service (Garage Miraloma) | MLO Service (Garage Miraloma) |
| Date/hour:    | 2020/01/17 15:49:44         | 2019/10/14 11:17:55           | 2019/10/14 08:38:55           |
| Parameters:   | 00155807 Rev:A15            | 00155807 Rev:A15              | 00155807 Rev:A14              |
| Program/Date: | 06100061 Rev:P44 2020-01-16 | 06100061 Rev:P43 2017-10-03   | 06100061 Rev:P43 2017-10-03   |

Description: Added parameter (EFDSAC) for aftermarket EFD option on Small A/C equipped vehicles. Parameter disables cooling request from A/C system to radiator fans.  
 Function 06200295 updated to P07  
 Function 06200367 updated to P12

Vehicle ID#:   **Messages: \*\*\* Other version of programs available \*\*\***  
**RECOMMENDATION: Generate and Transfer the Multiplex program!**  
 Vehicle generic program has changed since last generation!

General | Vehicle Parameters | Program Generation | Transfer to the Vehicle | Vehicle History |

Compare parameter values between  and

**Vehicle Parameters**

| Para   | Description                        | S | Default Value | Previous Value | Current Value | New Value |
|--------|------------------------------------|---|---------------|----------------|---------------|-----------|
| EFDSAC | Aftermarket EFD Kit on Small AC eq | N | Without       |                |               | With      |

## PARTS / WASTE DISPOSAL

Discard waste according to applicable environmental regulations (Municipal/State [Prov.]/ Federal)

## Appendix A

### STEEL – STEEL WELDING

**Caution:** Before welding, disconnect electronic modules and battery terminals.

**Warning:** Welding surfaces must be free of scale, slag, rust, paint, grease, humidity or other foreign material that would render welding impossible.

**Warning:** Only a qualified and experienced person must do welding.

- FCAW (Flux Cord Arc Welding) process;
- Electrode wire conforms to A5.20 AWS (American Welding Society) specifications;
- E4801T-9-CH, type electrode wire with 0,045 "diameter (1,14 mm);

| Material Thickness | Voltage      | Current  | Wire Feed Rate   | Shielding Gas                      |
|--------------------|--------------|----------|------------------|------------------------------------|
| 1/8" to 1/2"       | 26 ± 2 volts | 260 Amps | 450 ipm. approx. | 75% argon – 25% CO2<br>or 100% CO2 |

If necessary and with great care to prevent perforating the material, it is possible to use a conventional electric arc welding machine according to the following specifications:

- SMAW (Shielded Metal-Arc Welding) process;
- Welding rod conforms to A5.1 of AWS (American Welding Society) specifications; E 7018 type welding rod with 1/8" diameter (3,2 mm).
- Current: 100 amperes to 150 amperes; optimum at 120 amps.

It is important to grind weld bead starts and stops and also to grind arc strikes from surfaces.

### STEEL - STAINLESS STEEL OR STAINLESS STEEL - STAINLESS STEEL WELDING

**Caution:** Before welding, disconnect electronic modules and battery terminals.

**Warning:** Welding surfaces must be free of scale, slag, rust, paint, grease, humidity or other foreign material that would render welding impossible.

**Warning:** Only a qualified and experienced person must do welding.

- GMAW (Gas Metal-Arc Welding) process;
- Welding wire conforms to AWS (American Welding Standards) A5.9 specifications;
- 308LSi type welding wire with 0.035" diameter (0,9 mm);

### STEEL - STAINLESS STEEL WELDING

| Steel Thickness | SS Thickness | Voltage        | Current       | Wire Feed Rate  | Shielding Gas                |
|-----------------|--------------|----------------|---------------|-----------------|------------------------------|
| Less than 1/8"  | Any type     | 20 ± 1.5 volts | 130 ± 15 Amps | 290 ipm approx. | 90% He, 7.5% Ar,<br>2.5% CO2 |
| 1/8" and more   | Any type     | 22 ± 1.5 volts | 160 ± 15 Amps | 330 ipm approx. | 90% He, 7.5% Ar,<br>2.5% CO2 |

### STAINLESS STEEL - STAINLESS STEEL WELDING

| SS Thickness | Voltage        | Current       | Wire Feed Rate  | Shielding Gas                 |
|--------------|----------------|---------------|-----------------|-------------------------------|
| Any type     | 20 ± 1.5 volts | 130 ± 15 Amps | 290 ipm approx. | 90% He – 7.5% Ar,<br>2.5% CO2 |

If necessary and with great care to prevent perforating the material, it is possible to use a conventional electric arc welding machine according to the following specifications:

- SMAW (Shield Metal-Arc Welding) process;
- Welding rod conforms to AWS (American Welding Standards) A5.4 specifications; 308 L-17 type welding rod with 3/32" diameter (2,4 mm);
- Current: - 50 amperes to 90 amperes, optimum at 60 amperes.

It is important to grind weld bead starts and stops and also to grind arc strikes from surfaces.