

PREVOST

WARRANTY BULLETIN

WB25-02A

DATE :	January 2025	SECTION :	26 SLIDE-OUT
EXPIRATION:	January 2027		
SUBJECT :	SLIDE OUT PNEUMATIC MODULE MODIFICATION		

Revision: A

Change angle of the valve and the hoses routing

04-16-2025









APPLICATION

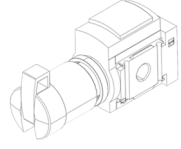
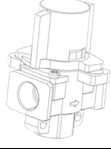

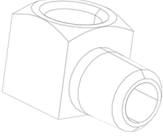
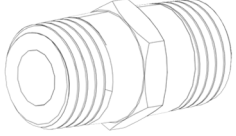

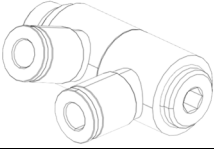
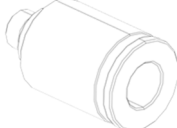

NOTICE TO SERVICE CENTERS <i>Verify vehicle eligibility by checking warranty bulletin status with SAP or via ONLINE WARRANTY SYSTEM available on Service / Warranty tab of Prevost website.</i>	
Model	VIN 
H3-45 VIP motorhomes Model Year: 2023 - 2024	From 2PCVS349X <u>PC721486</u> up to 2PCVS349X <u>RC721913</u> incl.
X3-45 VIP motorhomes Model Year: 2023 - 2024	From 2PCBS3497 <u>PC736885</u> up to 2PCBS3495 <u>RC736998</u> incl.
X3-45 VIP motorhomes Model Year: 2024	From 2PCBS3495 <u>RC734006</u> up to 2PCBS3496 <u>RC734063</u> incl.
X3-45 VIP commercial use Model Year: 2023 - 2024	From 2PCCS3494 <u>PC736878</u> up to 2PCCS3496 <u>RC736996</u> incl.
X3-45 VIP commercial use Model Year: 2024	From 2PCCS3499 <u>RC734000</u> up to 2PCCS3492 <u>RC734064</u> incl.
This bulletin does not necessarily apply to all the above-mentioned vehicles, some vehicles may have been modified before delivery. The owners of the vehicles affected by this bulletin will be advised by a letter indicating the Vehicle Identification Number (VIN) of each vehicle concerned.	

DESCRIPTION

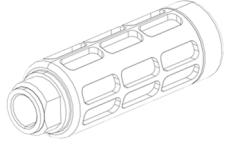
On the vehicles affected by this bulletin, you must modify the slide-out pneumatic module to avoid pneumatic problems.

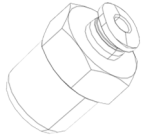
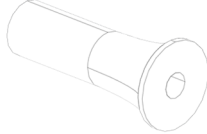
MATERIALOrder kit **WB25-02** which contains **142926** which contains the following parts:

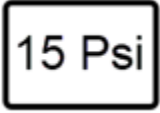
Part No	Description		Qty
640192 (527690)	AIR REGULATOR 0-203 PSI MAX		1
640143 (HVHS2000-02)	VALVE SHUT-OFF RELIEVING PORT		1
641373 (DPL1/2-N02S)	ELBOW 90° #8x1/4NPT-M		1
501332 (BFAPPX115B)	ELBOW 90° 1/4NPT-Mx1/4NPT-F		2
501264 (8008-04-04)	ADAPTER STRAIGHT 1/4NPT-M X 1/4 BSPT		1
501262 (8030282)	ADAPTER STRAIGHT 3/8 BSPT X 1/4 BSPT		1
640190 (558711)	ELBOW 90° 6MMx1/4 BSPP		1
501182 (3843)	PLUG M5 HEX		1
640124 (558840)	ELBOW 90° DUAL PORT 6MMx6MMx1/4 BSPP		1
640145 (558658)	ADAPTER STRAIGHT 6MMxM5-0.8		1
640144 (558782)	ELBOW 90° 6MMx6MM		1

640189 (534223)	MUFFLER		1
640139 (151547)	AIR FLOW REGULATOR		1
640193 (572306)	ADAPTER STRAIGHT #2x1/4NPT-M		1
640043 (564788)	PLUG 3/8 PUSH-IN		4
503040	TUBE, NYLON 6MM O.D. / WHITE 70mm		1
504273	CABLE TIE, NYLON BLACK (SMALL)		2
	DECAL 15 PSI		1
	DECAL 100 PSI		1
	SUPER GLUE		1

Other parts that required. **Note that these parts are not covered by this bulletin:**

Part No.	Description	Qty
680098	TEFLON LOCTITE 567 WHITE 250ML	AR
680038	THEREADLOCKER LOCTITE 243 BLUE 50 ML.	AR

NOTE
<i>Material can be obtained through regular channels.</i>

SAFETY PRECAUTIONS

- Eye protection should always be worn when working in a shop.
- Rules for Personal Protection Equipment should always be respected. Wear your PPE including but not limited to the following:



Safety First!



PROCEDURE



DANGER

Park vehicle safely, apply parking brake, stop the engine. Prior to working on the vehicle, set the ignition switch to the OFF position and trip the main circuit breakers equipped with a trip button. On the Commuter type vehicles, set the battery master switch (master cut-out) to the OFF position.

Lockout & Tag out (LOTO) must be performed during set-up, maintenance or repair activities. Refer to your local procedure for detailed information regarding the control of hazardous energy.

NOTE

Note that the modification shown is for a model with four slide-outs. It's the same modification regardless of the number of slide-outs.

NOTE

Note that one of the modifications to be made is to replace the dial-less pressure regulator with a dial-type regulator, which will facilitate adjustment.

REMOVE THE PNEUMATIC MODULE

1. Open the first street side baggage door.

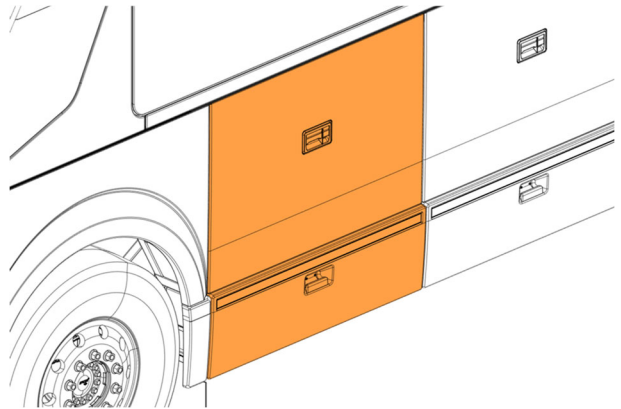

2. Locate the slide-out control panel.

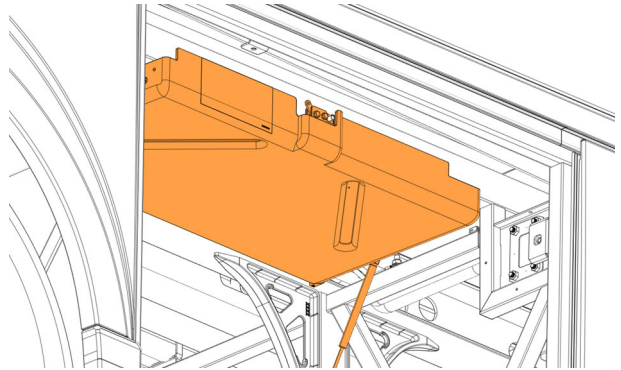

3. Open the control panel.

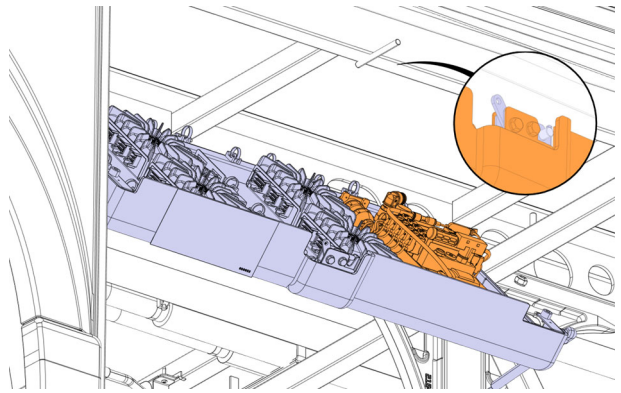

4. Disconnect the pneumatic module:

- The connector **CSo2**.
- The main air supply.

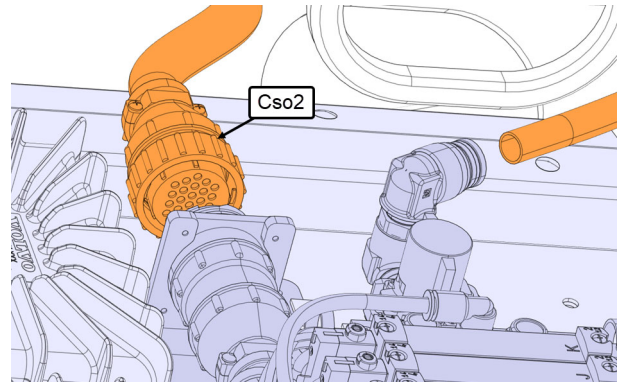

5. Mark the position of each slide-out seal hose on the pneumatic module.

6. Disconnect each slide-out seal hose from the pneumatic module.

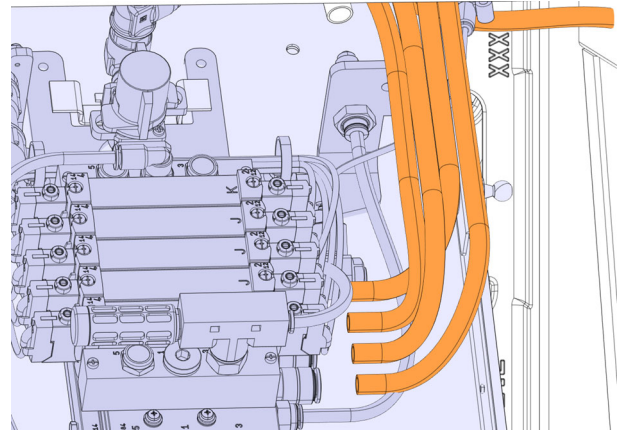

7. Disconnect security pin air supply from the pneumatic module.

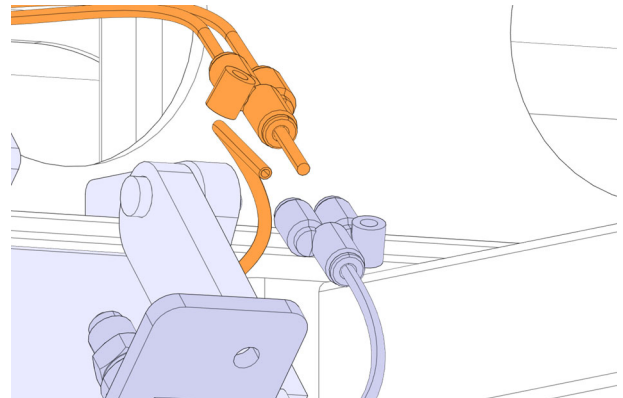

8. Remove the screws (3x) and remove the pneumatic module.

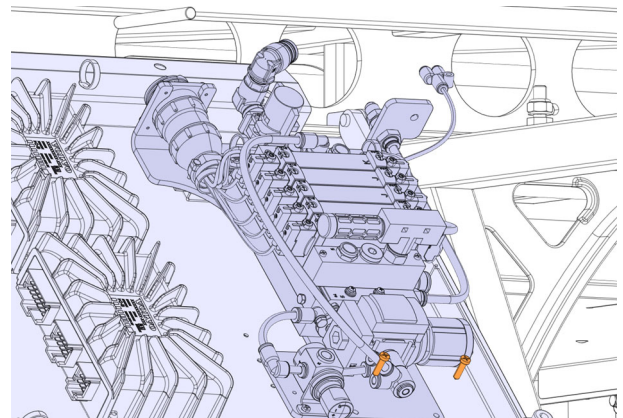

MODIFICATION OF THE REGULATOR 640192

1. Remove the plastic protector of the regulator 640192, holding it firmly at each end, with moderate pressure, lift with a bending movement. It is held in place by plastic clips.



2. Remove the lens of the regulator 640192, holding it firmly at each end, with moderate pressure, lift with a bending movement. It is held in place by plastic clips.



3. Apply a drop of glue to each fin (4x) and quickly replace the lens in its base.

Note: Be careful not to apply too much glue, as overfilling may cause the needle indicating the regulator pressure to stick and stop moving. And before reinstalling the lens, don't put too much weight on the needle. If it rubs against the cardboard, it creates a restriction that prevents it from moving.

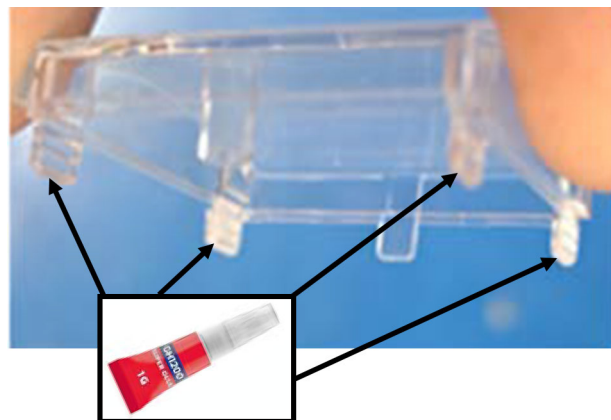

MODIFICATION OF THE PNEUMATIC MODULE

1. Apply thread sealant 680098 on the elbows 501332 (2x) and 641373 (1x) and adapter 501264.
2. Install the elbows 501332 (2x) on the shut-off valve 640143.
 - Install the inlet elbow parallel to the valve.
 - Install the outlet elbow perpendicular to the valve.
3. Install the elbow 641373 on the elbow 501332.
4. Install the adapter 501264 on the elbow 501332.

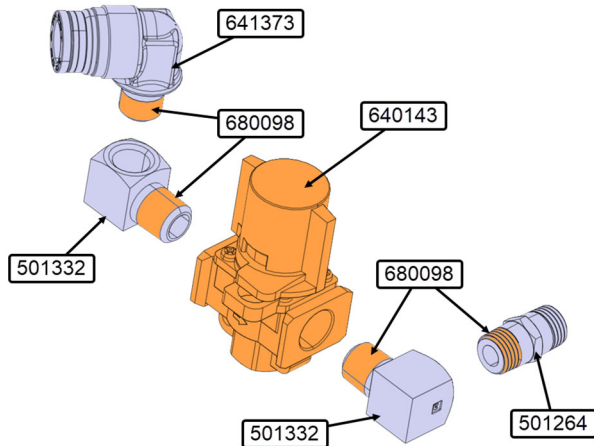

5. Apply thread sealant 680098 on the adapter 501264 of the valve assembly.
6. Install and position the valve assembly at an angle of approximately 20° degrees to the side of the port #1 of the regulator 640192, and make sure to secure it in place so that vehicle vibration does not displace it.

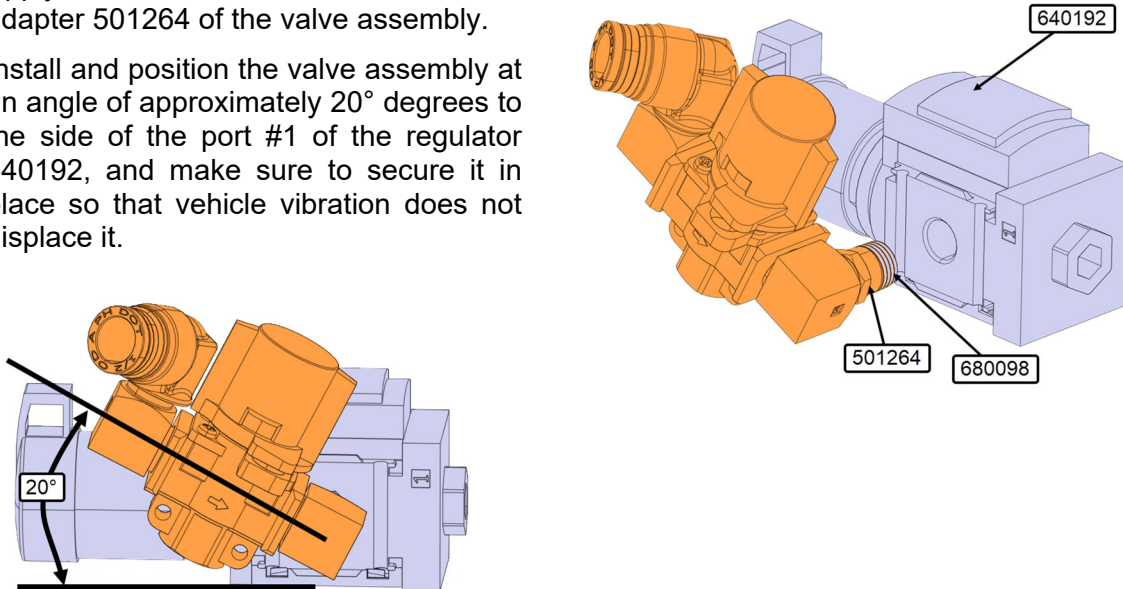

7. Remove the screws.
8. Disconnect the pressure regulator and discard.

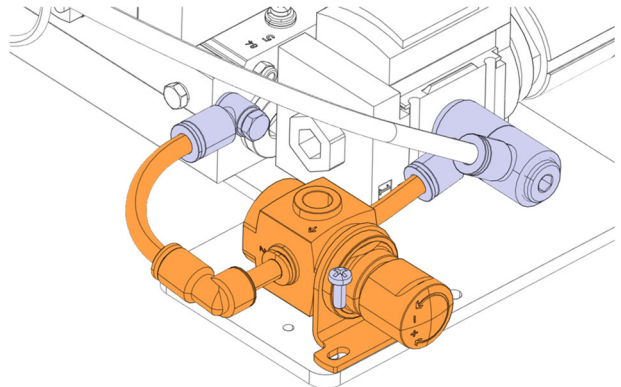

9. Remove the banjo union and discard.

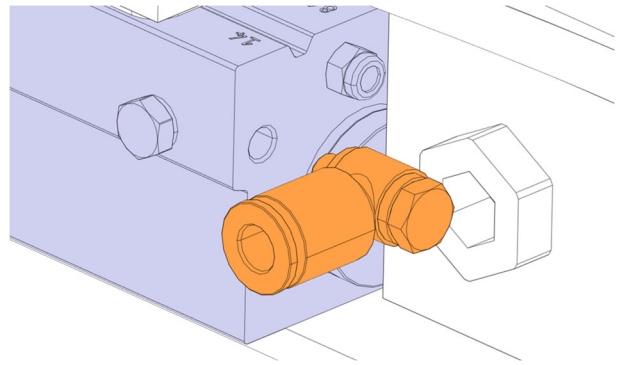

10. Install the adapter 640145 on the block valve.

11. Apply a torque of **13 lb-in.**

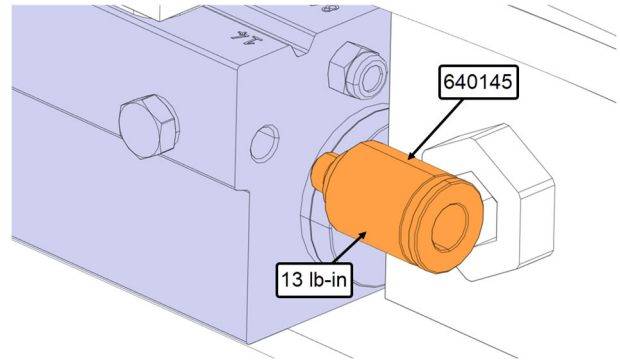

12. Disconnect the hose.

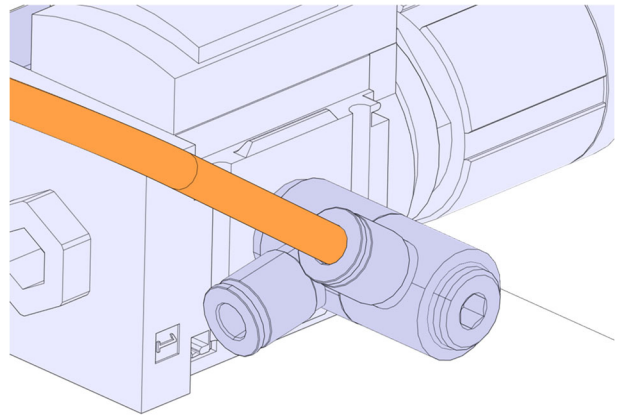

13. Reconnect the hose at the lower port of the fitting.

Note: Each time the tube is removed from a fitting, ideally cut back 5mm to remove the part damaged by the fitting.

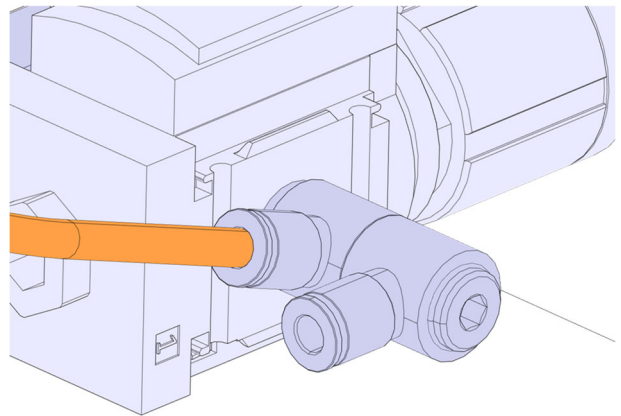

14. Connect the new hose 503040 (70mm) to adapter 640145.

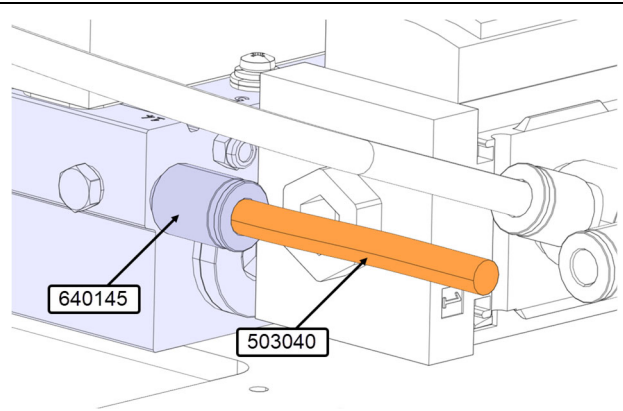

15. Connect the elbow 640144 to the hose 503040.

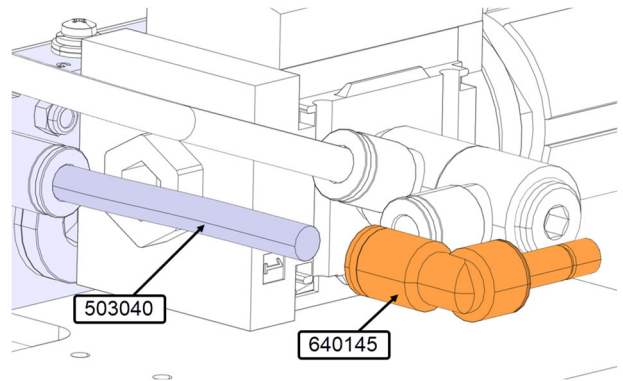

16. Reconnect the elbow 640144 at upper port of the fitting.

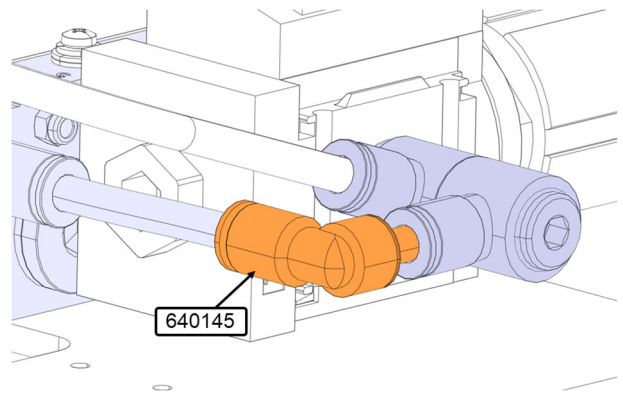

17. Remove the screws (4x) that secure the connector to the support.

18. Cut the cable tie.

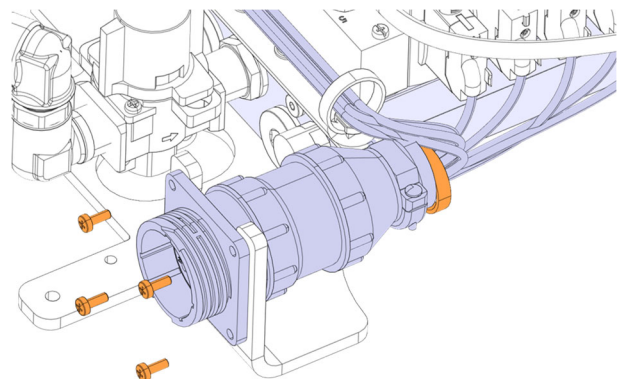

19. Unscrew the screws (2x) and the clamp from the connector.

Note: It is important to remove the clamp completely to avoid damaging the wiring when the connector is removed from its support.

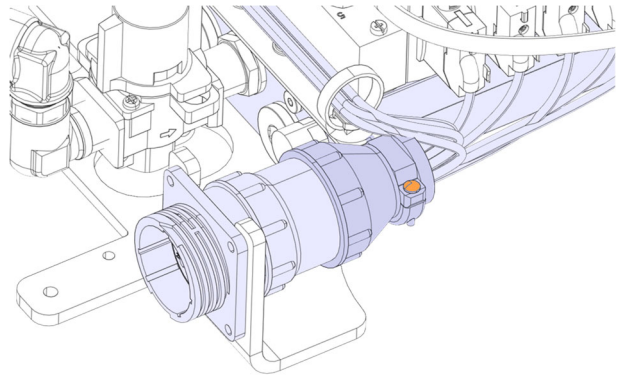

20. Unscrew the central section of connector, holding the connector firmly to prevent damage to the connectors and wiring, and then remove the connector assembly from its support.

Note: Do not over-pull/remove the central connector compartment to avoid damaging the wiring and connector.

It is advisable to screw the central compartment with the connector a little when it is removed from its support.

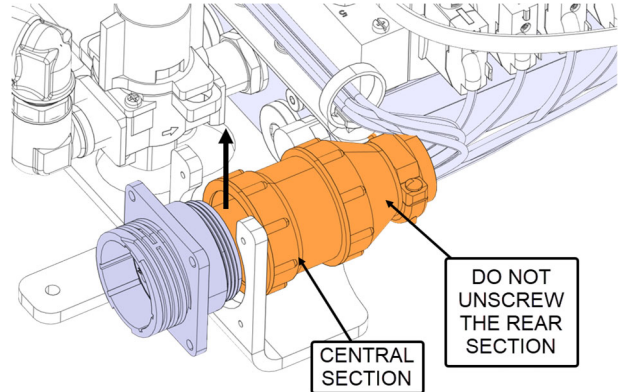

21. Disconnect the ¼ OD tube at both ends without turning it in the fitting cavities to avoid wearing away the outside of the tube and creating a leak

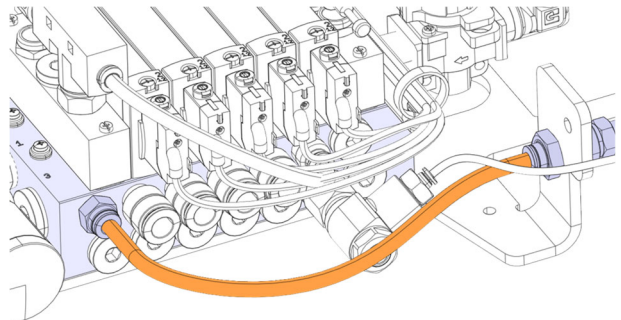

22. Remove the screws (4x), the lock washers (4x), the flat washer (6x) and the support.

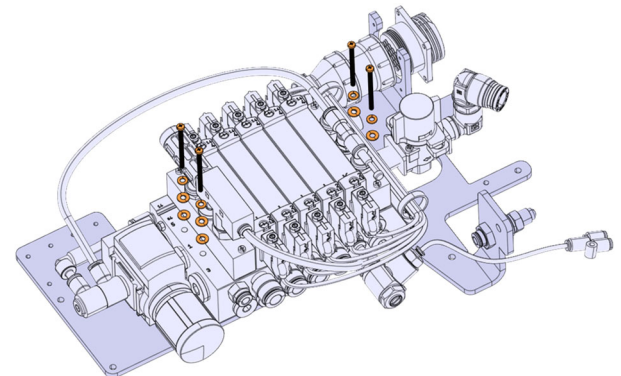

23. Remove the small pressure gauge and discard.

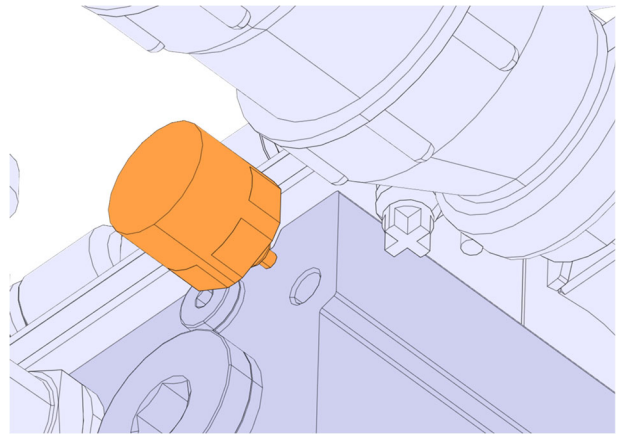

24. Install the plug 501182.
25. Apply a torque of **13 lb-in**

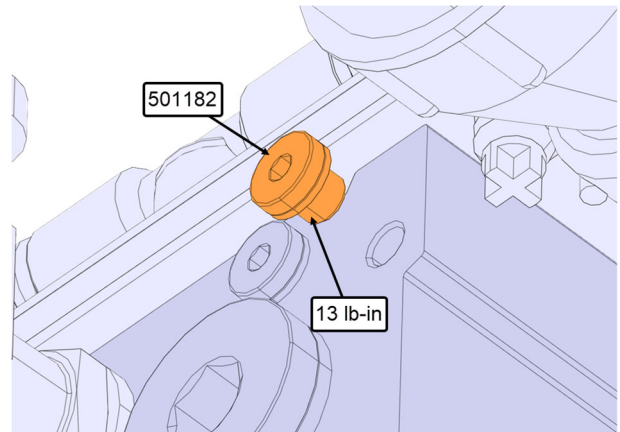

26. Verify if you have a T-connector.

- If yes go to next step.
- If no go to step 35.

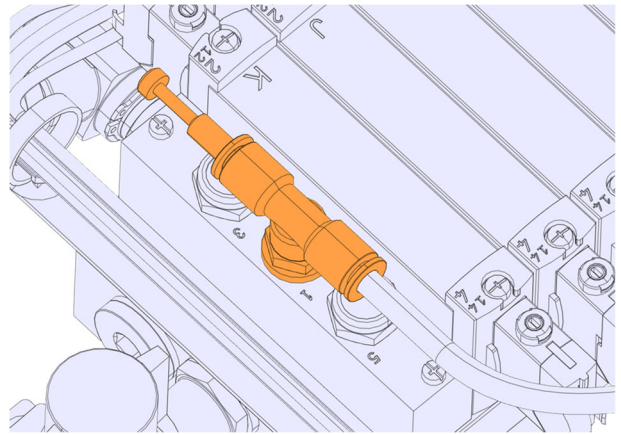

27. Disconnect the hose from the T-connector.

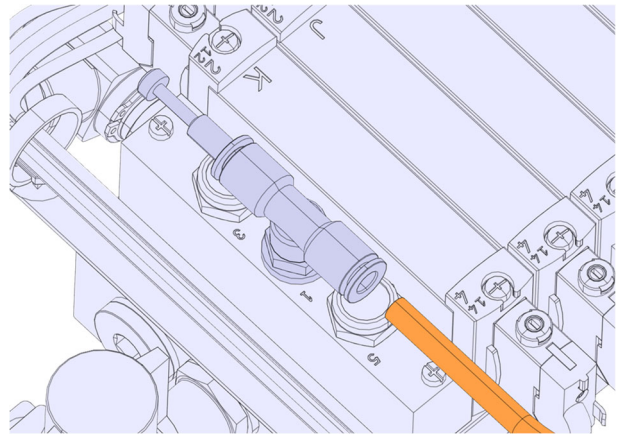

28. Remove the muffler.

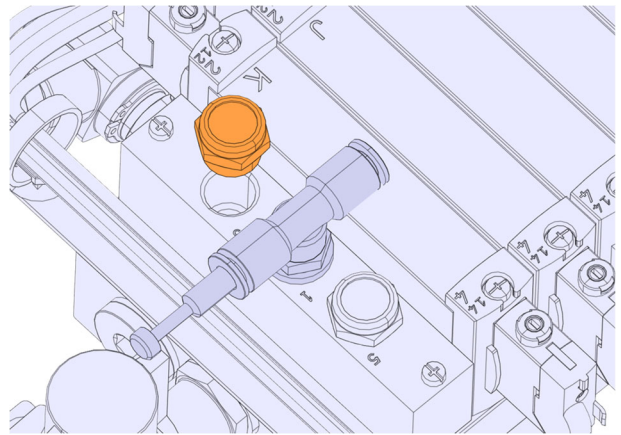

29. Remove the T-connector and discard.

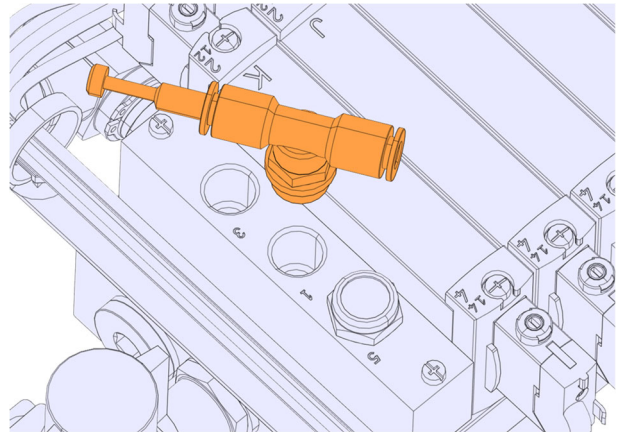

30. Install the elbow 640190.

31. Apply a torque of **7 lb-ft**.

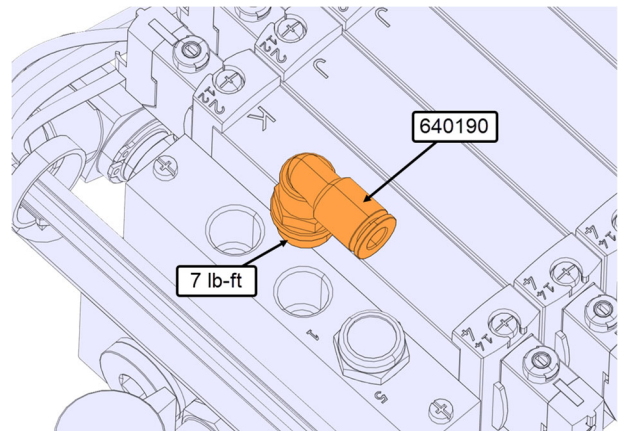

32. Reinstall the muffler.

33. Apply a torque of **11 lb-ft**.

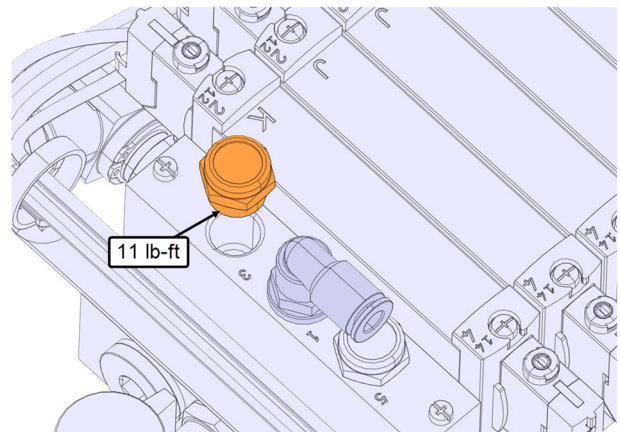

34. Reconnect the hose to the elbow 640190.

Note: Each time the tube is removed from a fitting, ideally cut back about 5mm to remove the part damaged by the fitting.

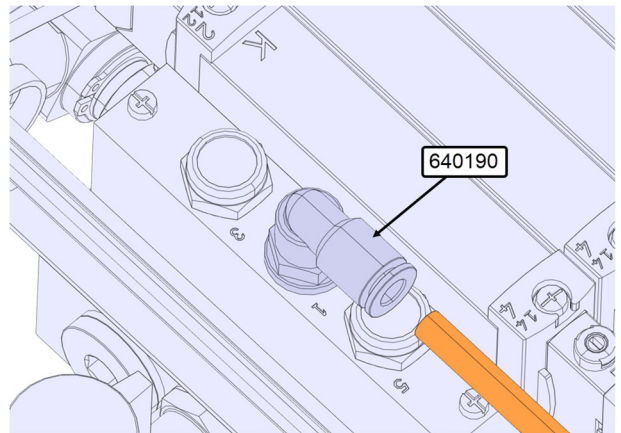

35. Remove the purge valve and discard.

Note: to remove the purge valve turn counterclockwise

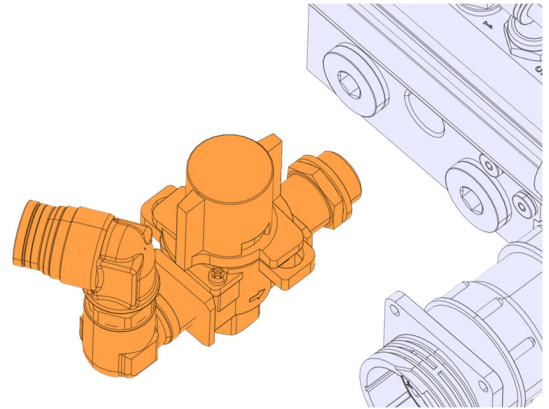

36. Apply thread sealant 680098 on the adapter 501262.

37. Install adapter 501262 on the new regulator assembly 640192.

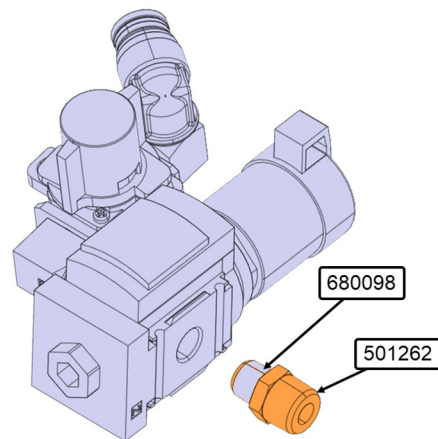

38. Apply thread sealant 680098 on the adapter 501262.

39. Install the new regulator assembly on the block valve.

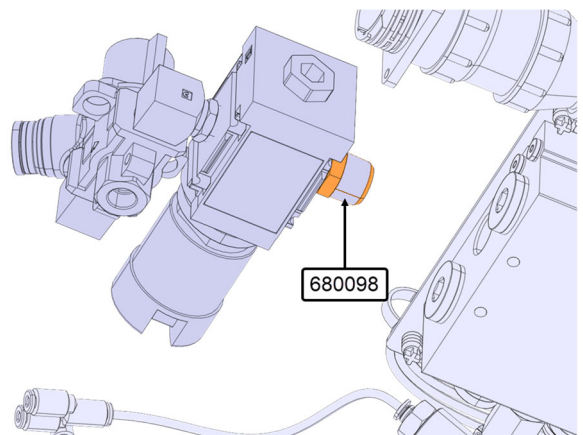

40. Reinstall the support on the block valve with the screws (4x), the lock washers (4x), the flat washer (6x).

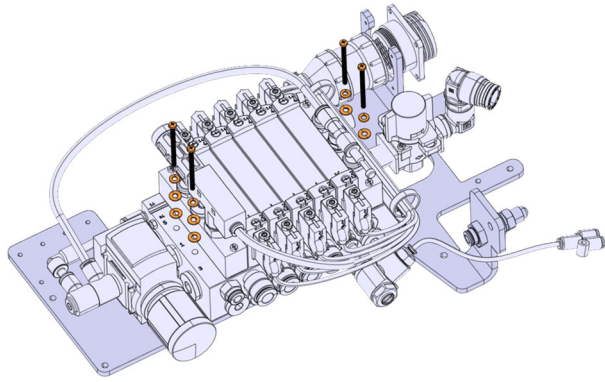

41. Reinstall the connector assembly on the support. Screw the central section of connector, holding the connector firmly.

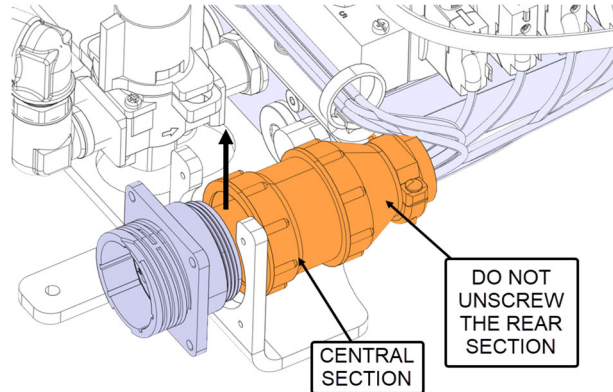

42. Reinstall the clamp on the connector with the screws (2x).

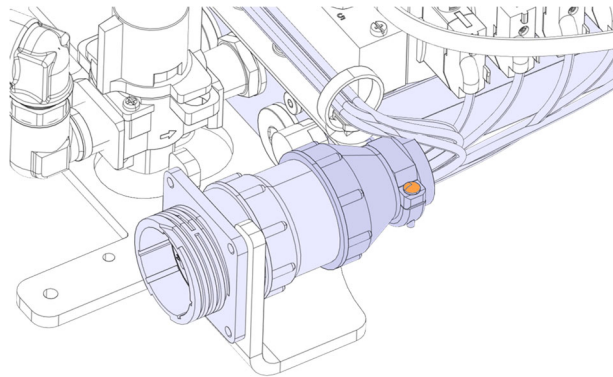

43. Secure the connector to the support with the screws (4x).

44. Install the new cable tie.

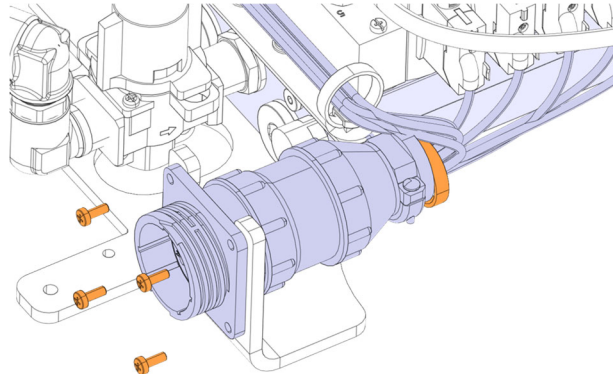

45. Verify the muffler model:

- If look like this, it is ok
- If not, replace by the new muffler 640189.

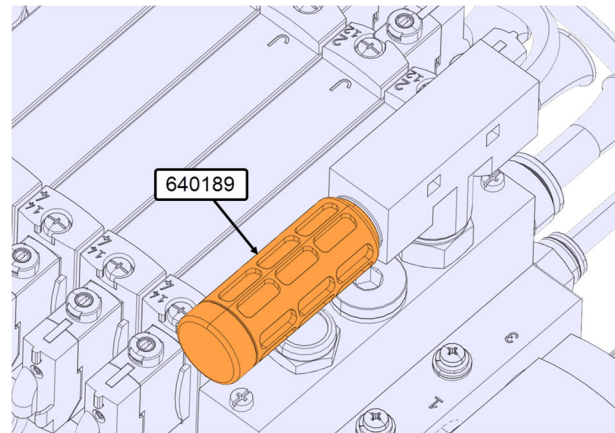

46. Verify the speed regulator model:

- If look like this, it is ok
- If not go to next step.

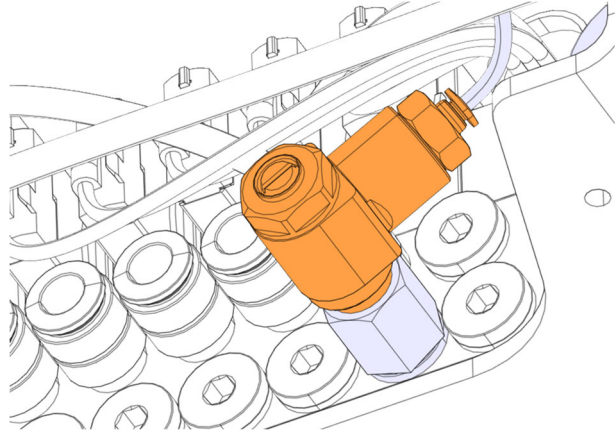

47. Disconnect the hose and remove the old speed regulator and discard.

48. Apply thread sealant 680098 on the speed regulator 640139 (2x) and on the adapter 640193 (1x).

49. Install the adapter 640193 on the new speed regulator 640139.

50. Install the assembly on the block valve.

51. Apply a torque of **7 lb-ft**

52. Reconnect the hose.

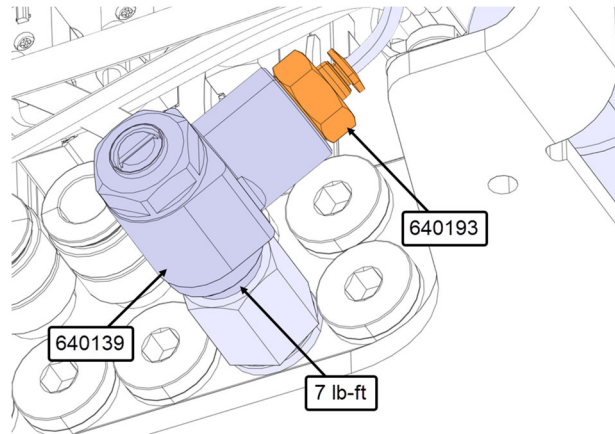

SET THE REGULATORS

1. Pressurize the system to +/- 140 psi as the vehicle pressure at the valve block inlet (Requires 1/2" OD tubing).

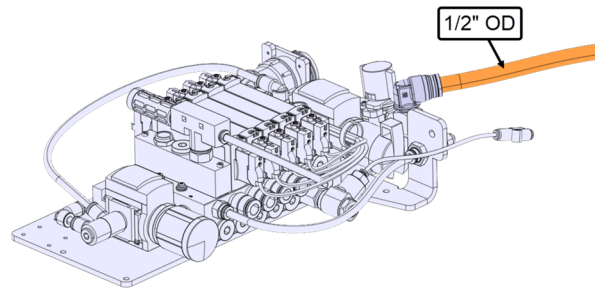

2. Position purge valve in closed position.

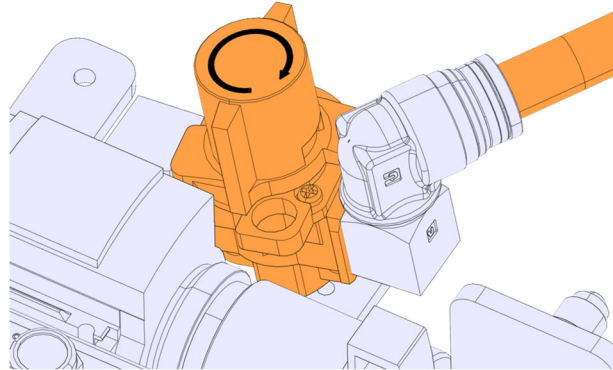

3. Install plugs 640043 (4x) in the fittings to prevent air from escaping when adjusting the pressure regulator.

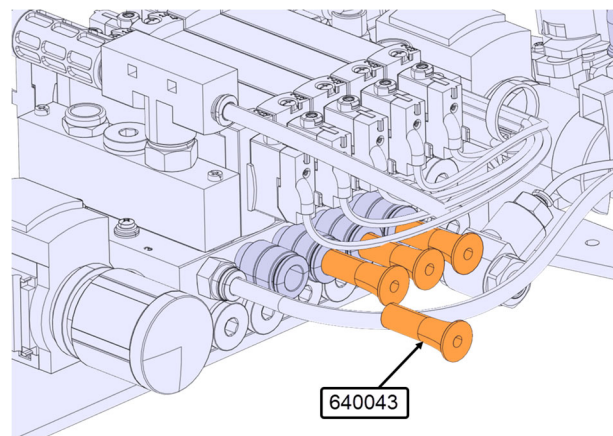

4. Verify if you have air leak with water with soap.

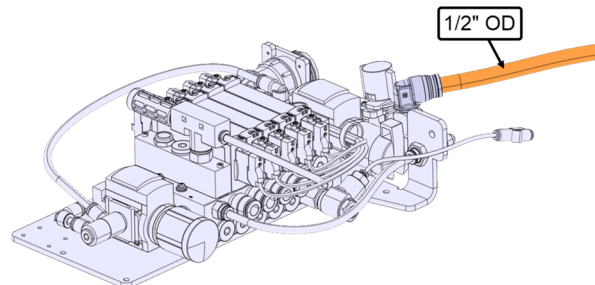

5. Lower the control knob to adjust pressure.

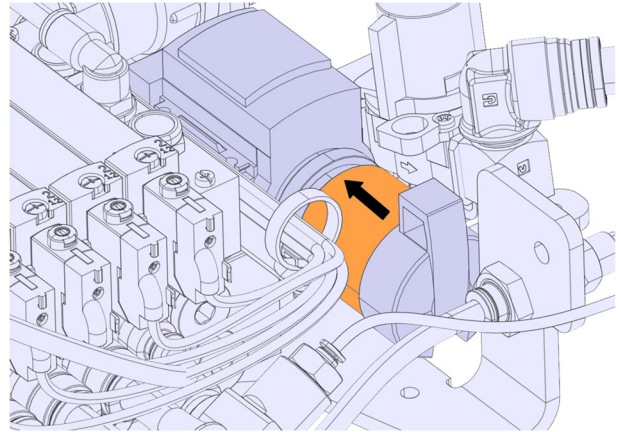

6. Turn clockwise (+) until pressure gauge needle reads **100 psi**.

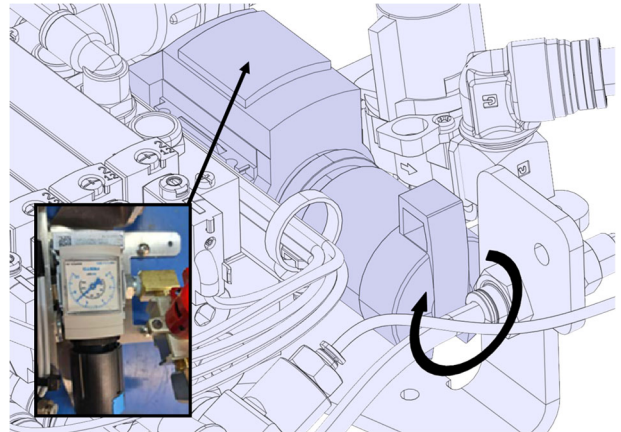

7. Push the knob into the locked position and install the cable tie on the lock mechanism as a safety device. It will then no longer be possible to turn the knob to change the regulator pressure.

8. Install the decal 100Psi.

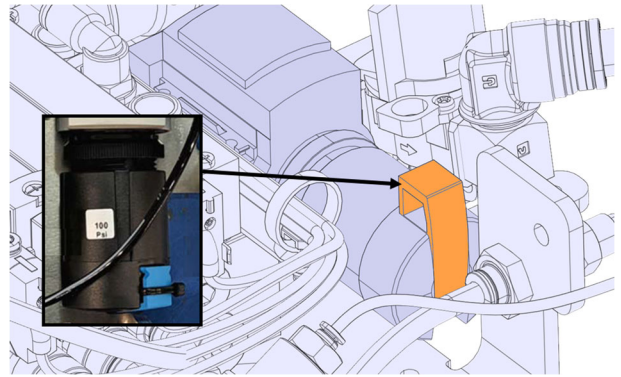

9. Check speed regulator adjustment, turn the speed regulator adjustment screw all the way clockwise to close the needle completely. Then turn counterclockwise only 1/2 turn to open the speed control needle a little, which will reduce the speed of the rod of the locking cylinders of the slide-out.

Note: It will be possible to check/test the output speed of the lock cylinders during installation and readjust if necessary.

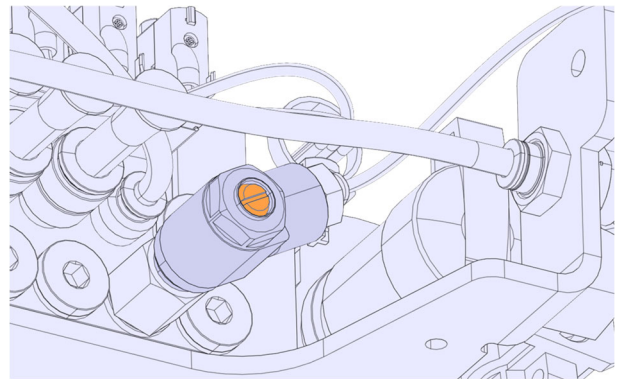

10. Before to adjust the secondary regulator, manually actuate a few times the two hand levers (Manuel-override) of each pilot of one of the valves used to inflate/deflate the slide-out seals (Valve #2 - #3- #4 - #5, except valve #1).

Note: Use a small precision screwdriver and apply a little pressure by pushing lightly to operate the pilot; it is possible to turn it when pushed to lock it in the continuous operating position.

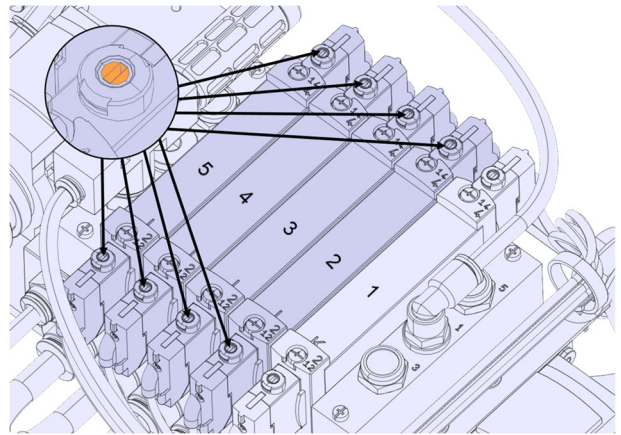

11. Verify if the pressure gauge needle reads **15 psi**.

- If not, got to next step.
- If yes, got to step 16

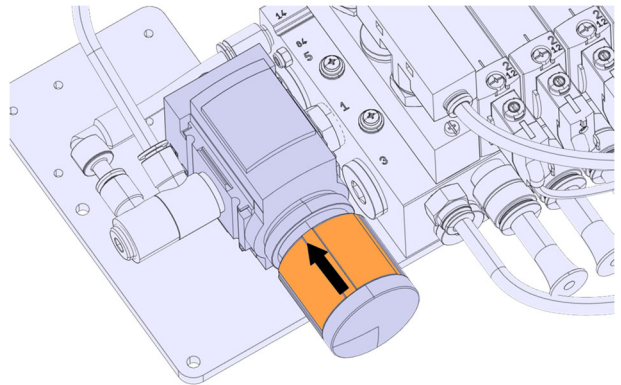

12. Turn clockwise (+) until pressure gauge needle reads **15 psi**.

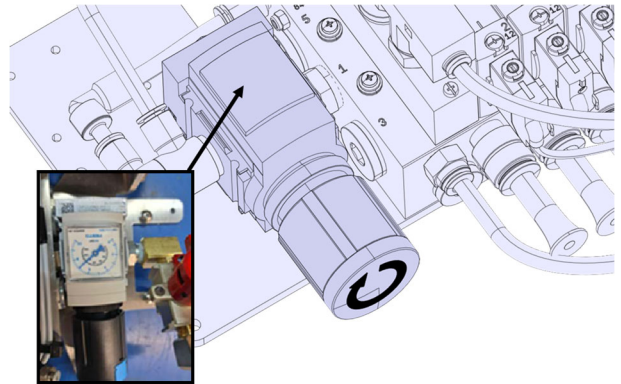

13. Push the knob into the locked position and install the cable tie on the lock mechanism as a safety device. It will then no longer be possible to turn the knob to change the regulator pressure.

14. Install the decal 15Psi.

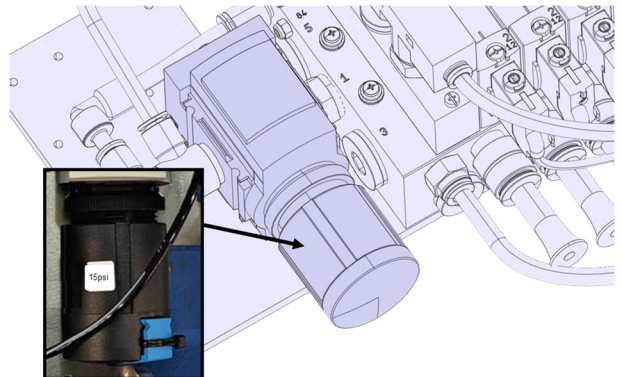

15. When adjustment is complete, remove the plugs 640043 (4x).

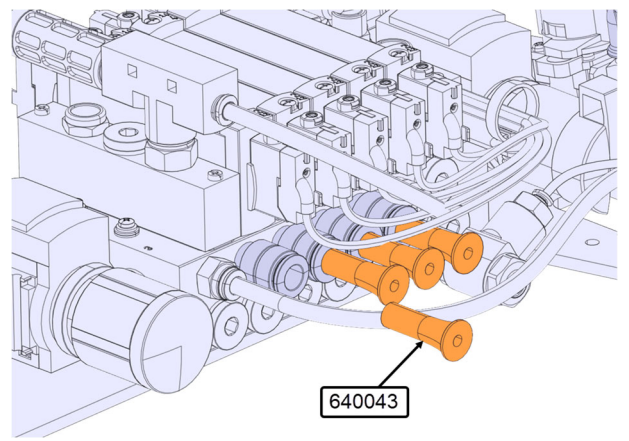

REINSTALL THE PNEUMATIC MODULE

1. Reinstall the pneumatic module with the screws (2x).

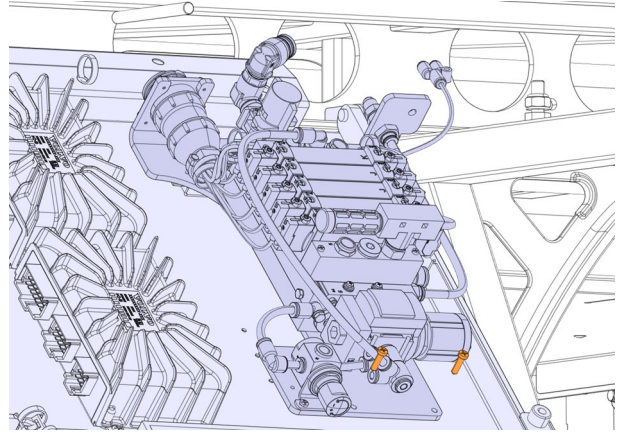

2. Reconnect the pneumatic module seal air supply of each side out at the same position on the module.

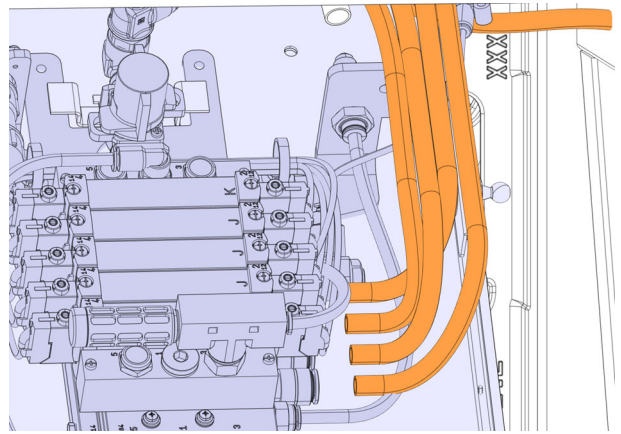

3. Reconnect the pneumatic module security pin air supply.

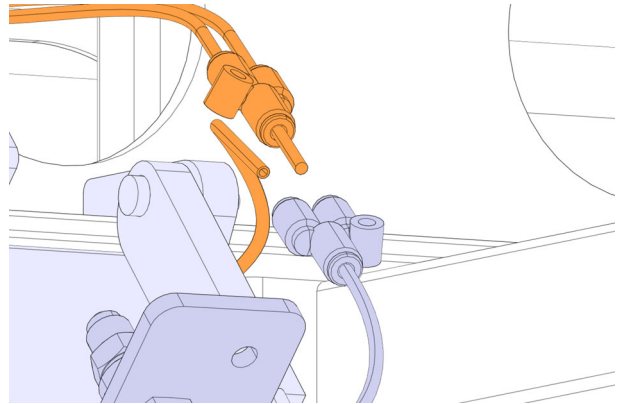

4. Reconnect the pneumatic module:
 - The connector **Cso2**.
 - The main air supply.

Note: the main air supply hose must pass under the seal air supply hose.

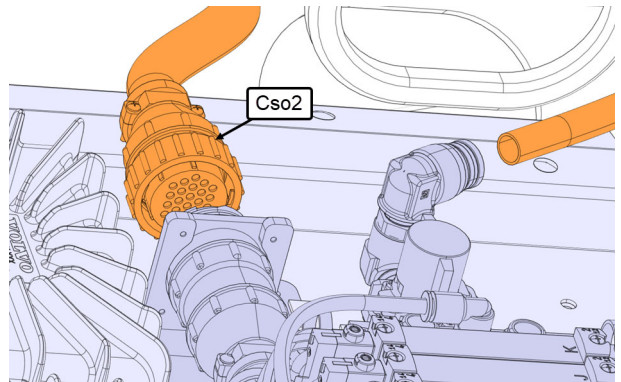

5. Verify all slide-out inflatable seal operation.

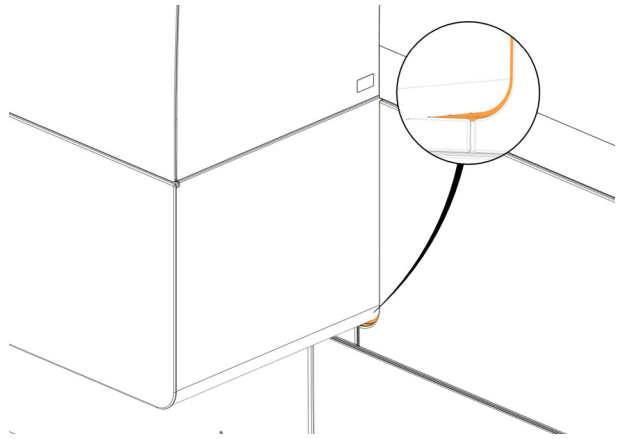
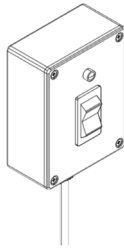

6. Close the slide-out control panel.

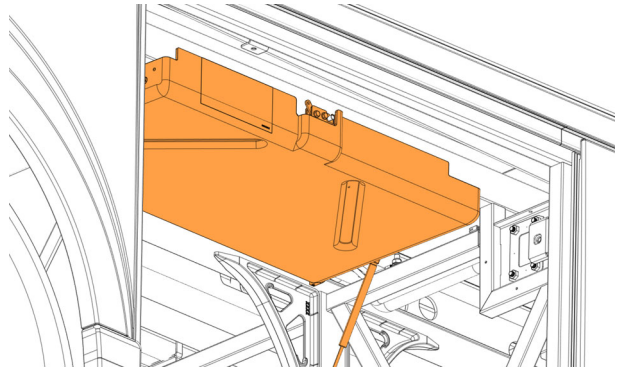

7. Close the first street side baggage door.

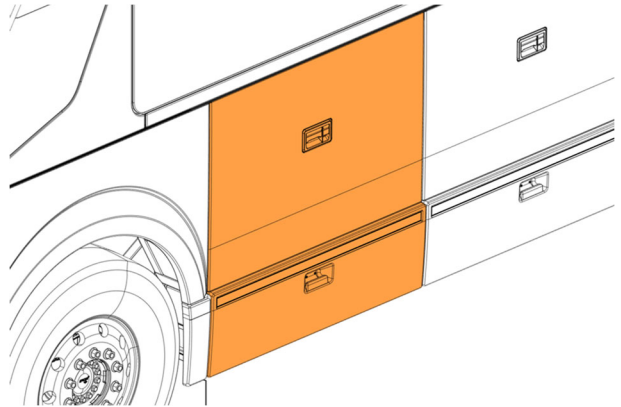

PARTS / WASTE DISPOSAL

DO NOT RETURN THE REPLACED PARTS. Discard waste according to applicable environmental regulations (Municipal/State[Prov.]/ Federal)

WARRANTY

This modification is covered by Prevo's normal warranty. We will reimburse you the parts and one hour and half (1.5) of labor upon receipt of a warranty claim. Please submit claim via our Online Warranty System, available at www.prevo.com (under Service \ Warranty section).

OTHER

VBC Bulletin	N/A
Fail Code	26.02
Defect Code	09
Syst. Cond	B
Causal Part	140584

Access all our Service Bulletins on
<http://techpub.prevo.com/en/>
 or scan the QR-Code with your smart phone.



Are you a Vehicle owner? E-mail us at
technicalpublications_prev@volvo.com and type "ADD" in the
 subject to receive warranty bulletins applicable to your vehicle(s)
 by e-mail.