

SECTION 13: WHEELS, HUBS AND TIRES

CONTENTS

SECTION CHANGE LOG	3
1. TORQUE TABLES	4
1.1 WHEEL NUTS.....	4
1.2 TAG AXLE	4
1.3 I-BEAN AXLE & FORMER IFS DESIGN.....	5
1.4 NEW IFS DESIGN	5
1.5 MERITOR DRIVE AXLE	6
1.6 ZF A132 DRIVE AXLE.....	6
2. WHEELS	7
2.1 H3-45 & X3-45 COACHES	7
2.2 H3-45 VIP & X3-45 VIP MOTORHOMES	7
3. WHEEL MAINTENANCE	8
3.1 INSPECTION	8
3.2 SINGLE WHEEL REMOVAL.....	8
3.3 SINGLE WHEEL INSTALLATION.....	8
4. DUAL WHEELS	9
4.1 OUTER WHEEL REMOVAL	9
4.2 INNER WHEEL REMOVAL	9
4.3 INNER WHEEL INSTALLATION	9
4.4 OUTER WHEEL INSTALLATION	9
4.5 INSPECTION	9
5. ALUMINUM WHEEL ANTI-CORROSION PROTECTION (WITHOUT DURA-BRIGHT)	10
6. WHEEL STRAIGHTNESS TEST	11
7. WHEEL STUDS	12
7.1 DRIVE AXLES WHEEL STUDS.....	12
7.2 FRONT AND TAG AXLE WHEEL STUDS	12
8. HUB MOUNTED WHEELS	13
8.1 CARE OF WHEELS.....	13
9. WHEEL HUBS - TAG AXLE	14
9.1 TAG AXLE HUB UNITIZED BEARING INSPECTION	15
9.2 TAG AXLE HUB BEARING REMOVAL.....	16
9.3 TAG AXLE HUB BEARING INSTALLATION.....	18
10. WHEEL HUB - INDEPENDENT FRONT SUSPENSION (NEW IFS DESIGN)	22
10.1 NEW IFS DESIGN HUB REMOVAL	22
10.2 NEW IFS DESIGN HUB INSTALLATION	24
10.3 NEW IFS DESIGN UNIT-BEARING INSPECTION	27
10.4 NEW IFS DESIGN UNIT-BEARING REPLACEMENT (HUB REMOVED).....	28
11. WHEEL HUBS - FRONT AXLE	31
11.1 FRONT AXLE HUB BEARING INSPECTION	32

SECTION 13: WHEELS, HUBS AND TIRES

11.2	FRONT AXLE HUB BEARING REMOVAL	32
11.3	FRONT AXLE HUB BEARING INSTALLATION	32
12.	MERITOR DRIVE AXLE WHEEL HUBS	33
12.1	BEARING CHECK/ADJUSTMENT	33
12.2	DISASSEMBLY AND REPAIR	34
13.	ZF DRIVE AXLE WHEEL HUBS	35
13.1	COMPACT BEARING (HUB UNIT) AXIAL PLAY CHECK	35
13.2	COMPACT BEARING (HUB UNIT) GREASE CHANGE	35
14.	SPARE WHEEL	37
14.1	SUPER SINGLE TIRE REPLACEMENT	37
14.2	PULLING OUT SPARE WHEEL	37
14.3	CHANGING A FLAT TIRE (COACHES ONLY)	38
14.4	CHANGING A FLAT TIRE (VIP & CONVERTED BUS SHELLS).....	38
14.5	SPARE WHEEL MAINTENANCE	39
15.	VALVE INSTALLATION.....	40
15.1	TPMS SENSORS INSTALLATION	41
16.	TIRE MAINTENANCE.....	43
16.1	INFLATION PRESSURE	43
16.2	TIRE MATCHING	45
16.3	WHEEL BALANCING	45
16.4	TIRE ROTATION	45
17.	SPECIFICATIONS	46

SECTION CHANGE LOG

DESCRIPTION		DATE
1	Updated for new IFS design	March 2025
2		
3		
4		
5		
6		

1. TORQUE TABLES

1.1 WHEEL NUTS

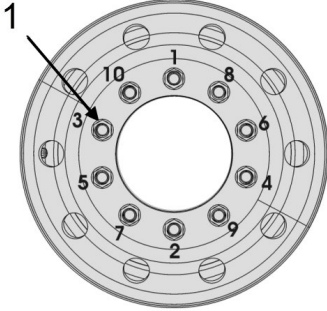

WHEEL NUTS (ALL TYPES) – STEEL/ALUMINUM WHEELS		
No	DESCRIPTION	TORQUE
1	Wheel nuts (M22x1.5 threads)*	450-500 lb-ft (610-678 Nm)

*Torque following sequence shown

1.2 TAG AXLE

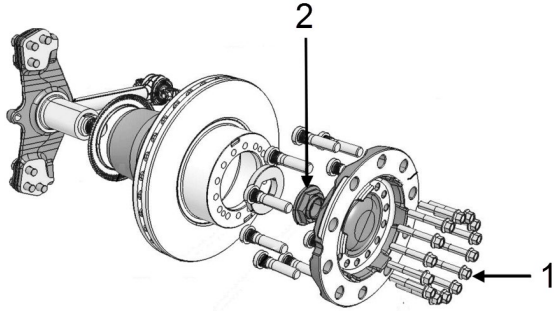

TAG AXLE		
No	DESCRIPTION	TORQUE
1	Tag axle hub flange cap screws	161-197 lb-ft (218-267 Nm)
2	Tag axle hub nut	563-687 lb-ft (763-931 Nm)

1.3 I-BEAN AXLE & FORMER IFS DESIGN

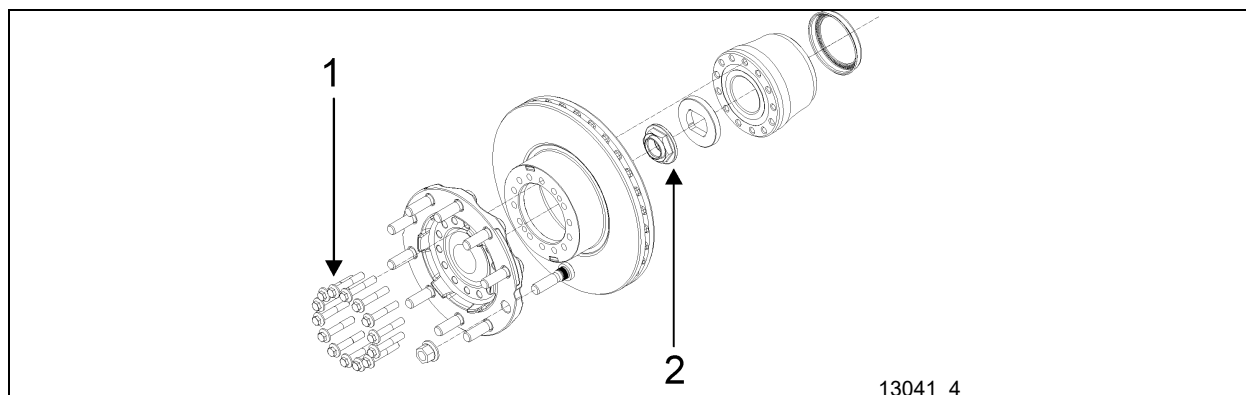

13041_4

FRONT AXLE

No	DESCRIPTION	TORQUE
1	Front axle hub flange cap screws	Erreur ! Liaison incorrecte.
2	Front axle hub nut	575-625 lb-ft (780-847 Nm)

1.4 NEW IFS DESIGN

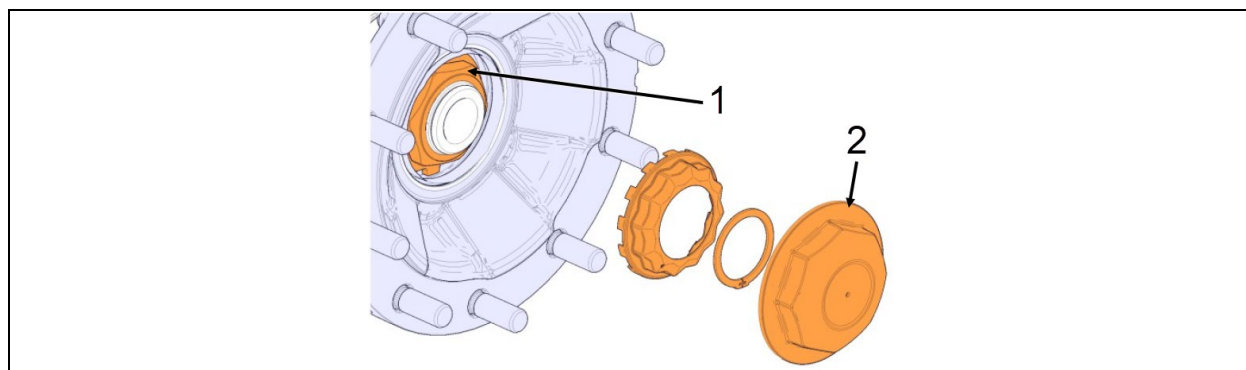

No	DESCRIPTION	TORQUE
1	Hub nut (hexagon)	Pre-tightening steps a) Tighten to 150 ± 30 Nm (110 ± 22 lb·ft) b) Rotate the hub 20 – 30 rev. Final tightening steps 1100 ± 110 Nm (811 ± 81 lb·ft)
2	Hub cap	332-405 lb-ft (450-549 Nm)

1.5 MERITOR DRIVE AXLE

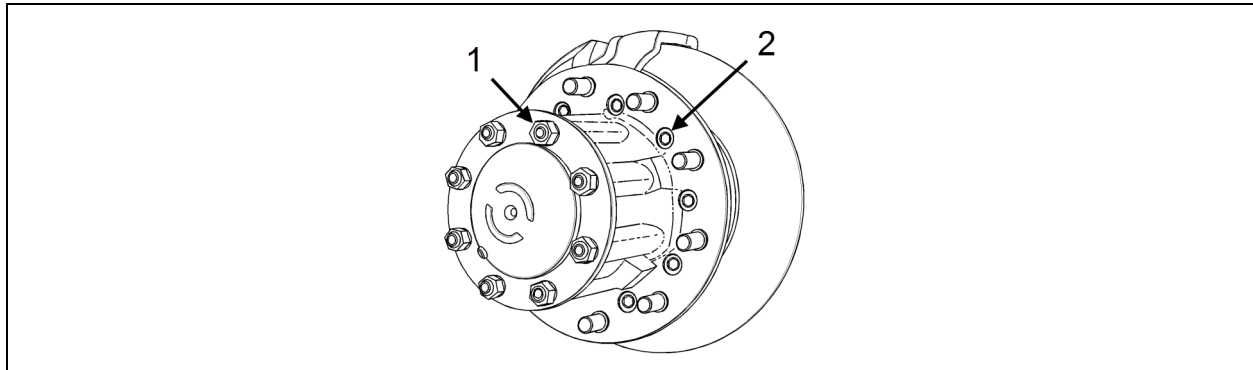

MERITOR DRIVE AXLE

No	DESCRIPTION	TORQUE
1	Drive shaft flange nuts 5/8-18	150-230 lb-ft (203-312 Nm)
2	Hub to disc cap screws 9/16-18	110-165 lb-ft (149-224 Nm)

1.6 ZF A132 DRIVE AXLE

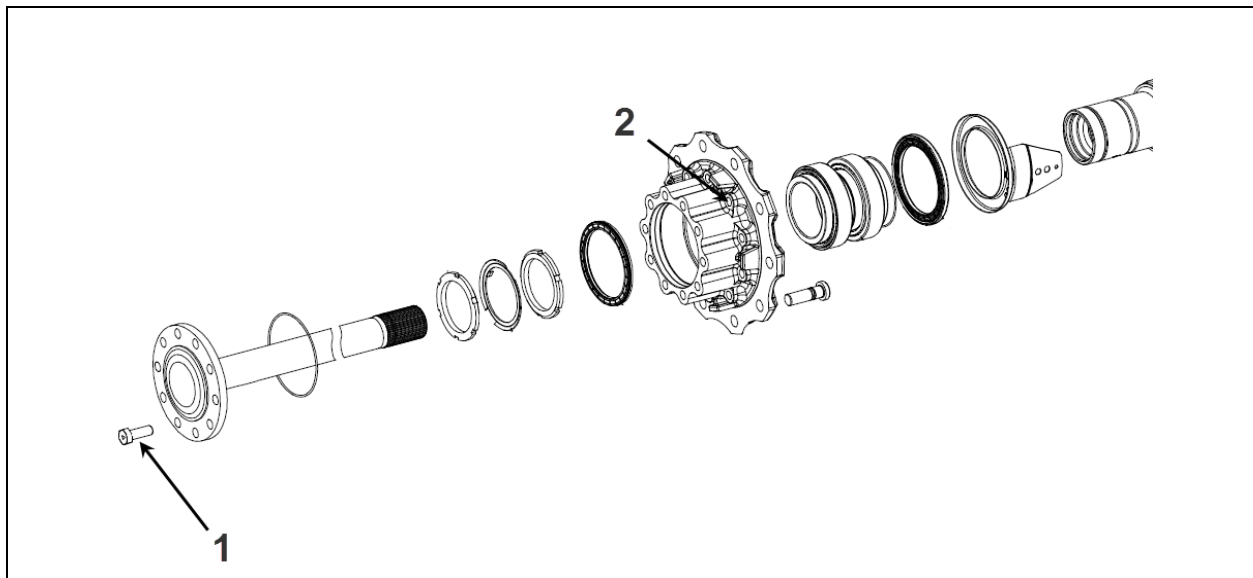

ZF A132 DRIVE AXLE

No	DESCRIPTION	TORQUE
1	Drive shaft flange bolts cap screw M18x1.5x50mm G10.9	325 lb-ft (441 Nm)
2	Hub cap screw Torx M16x1.5x60	221 lb-ft (300 Nm)

2. WHEELS

The vehicle is equipped with hub-mounted wheels as standard equipment, all studs and nuts have right-hand threads. Either steel wheels or optional aluminum-polished wheels may be installed on the vehicle. Both are mounted with radial tubeless tires. Dura-Bright surface treatment on aluminum wheels is optional.

2.1 H3-45 & X3-45 COACHES

Except for customer special request, all wheel dimensions are 22.50 X 9.0 inches (571.5 X 228.6 mm) for 315/80 R 22.5 "L" tires.

All wheels can either be steel or aluminum.

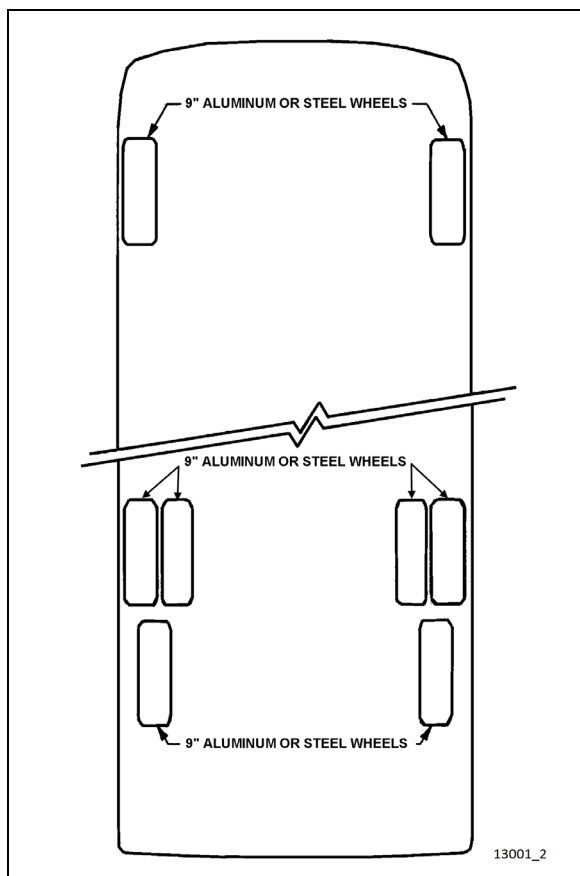

FIGURE 1: ALUM/STEEL WHEEL ARRANGEMENT

tires while front and tag axle wheels are 22.50 X 10.5 inches (571.5 X 266.7 mm) for 365/70 R 22.5 tires.

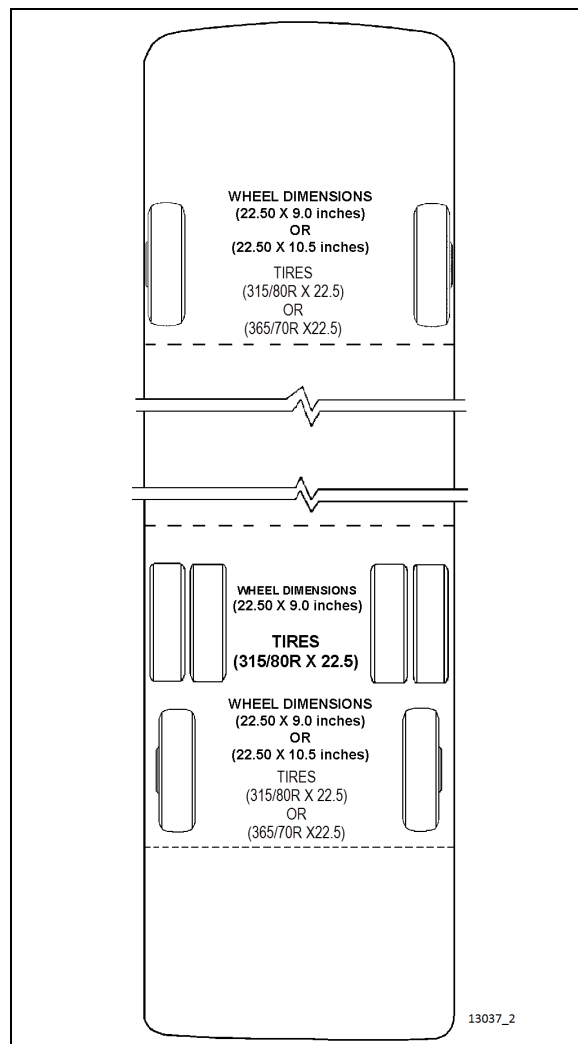

FIGURE 2: WHEEL ARRANGEMENT

13037

NOTE

Wide base "Super Single" tire are available as an option to replace both drive axle wheels and tires by a single 455/55 X 22.5 tire mounted on a 14 inches wheel.

2.2 H3-45 VIP & X3-45 VIP MOTORHOMES

Drive axle wheel dimensions are 22.50 X 9.0 inches (571.5 X 228.6 mm) for 315/80 R 22.5

3. WHEEL MAINTENANCE

Wheel maintenance consists of periodic inspections. Check all parts for damage and make sure that wheel nuts are tightened to the proper torque. In the case of a new vehicle, or after a wheel installation, stud nuts should be tightened every 100 miles (160-km) for the first 500 miles (800-km) to allow setting in of clamping surfaces.



CAUTION

Wheel studs and nuts must be kept free from grease and oil. No lubricant whatsoever should be used. Cleanliness of the wheel and its rotor mating surfaces is important for proper wheel mounting.

It is recommended to add some rust protection lubricant on the outside diameter of the hub (to facilitate future removal).

It is also important that wheel stud nuts be tightened alternately on opposite sides of the wheel. Refer to Figure 3 for the suggested tightening sequence.

3.1 INSPECTION

Tighten stud nuts progressively as shown in Figure 3. The final tightening should be done with a torque wrench.

TORQUE (aluminum & steel wheels):
450-500 lb-ft (610-678 Nm)

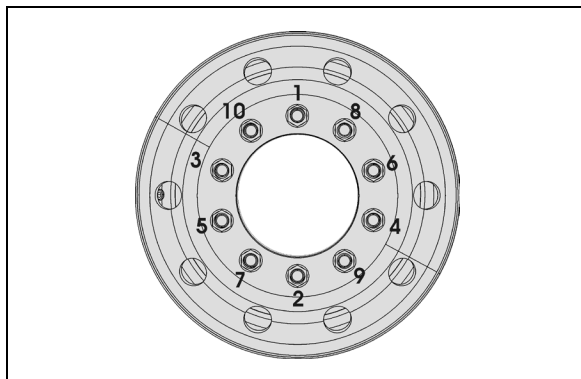

FIGURE 3: TIGHTENING SEQUENCE

13018

3.2 SINGLE WHEEL REMOVAL

1. Stop engine and apply parking brake.
2. Loosen wheel nuts about one turn (do not remove the nuts). This is not necessary if equipped with hydraulic powered gun.
3. Raise the vehicle by its jacking points on the body. See Section 18, "Body", under heading "Vehicle Jacking Points";
4. Unscrew wheel hex stud nuts and remove the wheel;



CAUTION

Always mark position of the wheel on the axle prior to removal in order to replace wheel at the same location, thus avoiding a new wheel balancing.

3.3 SINGLE WHEEL INSTALLATION

1. Mount the wheel over studs, being careful not to damage stud threads;
2. Screw in the hex stud nuts (refer to Figure 3 for sequence) so that wheel will position itself concentrically with hub. This is important, otherwise wheel may be eccentric with hub and will not run straight. In this initial step, slightly tighten the nuts to correctly position the wheel;
3. Tighten stud nuts progressively as shown in Figure 3. The final tightening should be done with a torque wrench.

TORQUE (aluminum & steel wheels):
450-500 lb-ft (610-678 Nm)



CAUTION

Insufficient mounting-torque can result in damage to parts. Excessive mounting torque can cause studs to break and the wheel to crack in stud hole area.

4. DUAL WHEELS

4.1 OUTER WHEEL REMOVAL

Same as described in "Single Wheel Removal" procedure described previously.

4.2 INNER WHEEL REMOVAL

1. Remove outer wheel;
2. Remove inner wheel.

4.3 INNER WHEEL INSTALLATION

Mount the wheel over studs, being careful not to damage stud threads;

4.4 OUTER WHEEL INSTALLATION

With inner and outer wheels installed, tighten the stud nuts progressively as shown in Figure 3. The final tightening should be done with a torque wrench.



CAUTION

Insufficient mounting-torque can result in damage to parts. Excessive mounting torque can cause studs to break and the wheel to crack in stud hole area.

NOTE

On dual wheel assemblies, position the wheels with the tire valves 180° apart in order to have access to both the inner and outer valves.

4.5 INSPECTION

1. Loosen a hex stud nut three turns (Figure 5);
2. Retighten the hex stud nut.

Repeat for each of the 10 "hex stud nuts" according to the tightening sequence in FIGURE 3.



CAUTION

The actual length of thread engagement present in an assembled wheel cannot always be determined by visual inspection or measurement of a tightened assembly. The relationship of the wheel cap nut seat to the end of the stud may vary. If there is any doubt that enough thread engagement is present, the number of engaged threads may be counted. Tighten all nuts in the regular manner, then loosen one to hand-tightness. The number of turns to disengage a 1-1/8-inch nut should be at least five full turns.

At least seven full turns should be required to disengage a 3/4-inch nut or a M22 nut. Ideally, when torqued to the proper load, the stud should be flush with the face of the nut. The face of the nut may be recessed in nuts that are taller for improved wrenching. With most of the nuts in present use, a few unengaged threads at the outer end will cause no problem provided at least 5-7 full turns are required to disengage the nut depending on thread size.

5. ALUMINUM WHEEL ANTI-CORROSION PROTECTION (WITHOUT DURA-BRIGHT)

Clean wheels often by means of a high pressure water jet. Cleaning may be accelerated with mild soap. Do not use concentrated alkaline cleaning products.

When tire is removed, clean and inspect wheel thoroughly. Remove dirt and corrosion on rim by means of a wire brush. Do not use a wire brush on the outer surface of the wheel.

The following measures should be taken to maintain original appearance of the aluminum wheels:

1. Remove any tar from wheel surface with a good quality tar remover.
2. Spray Alcoa Cleaner (Prevost #683529) evenly on cool outer surface of wheel. Let work 15-20 minutes (keep wet by spraying more Cleaner if necessary).
3. Rinse thoroughly with clean water and let air dry. Heavy oxidation may require a repeat application of cleaner.
4. Apply Alcoa Polish (Prevost #683528) sparingly to a small area using a clean, soft cloth. Work polish into surface as you would a rubbing compound.
5. Buff, turning cloth frequently, until surface is clean and shiny. Let air dry. Use power buffer to improve ease of use and gloss uniformity.
6. On completely dry, clean and polished surface, generously apply Alcoa sealant (Prevost #683527). Rinse thoroughly with water while surface is still wet in appearance (have water source ready as the dry time is very short, usually less than 2 minutes).
7. For best results, finish by wiping the surface with a clean rag to remove excess water, then allow surface to dry.



CAUTION

Dura-Bright is a special surface treatment that does not require polishing. Do not use abrasives, abrasive brushes steel wool scouring pads or strong chemicals on Dura-Bright wheels.

Do not use Alcoa Aluminum care system on Dura-Bright wheels, clean regularly with high pressure water jet and mild detergent.

Clean aluminum wheels as required to maintain original look.



WARNING

Wheel surfaces may have sharp or cutting edges that may cause injury to the hands. To prevent contact with sharp edges, it is strongly recommended to wear rubber gloves when washing or polishing wheels.

6. WHEEL STRAIGHTNESS TEST

1. Slightly raise axle to be checked and place a safety support underneath;
2. Check wheel lateral run-out. Install a dial gauge as shown in figure 4, then rotate the wheel by hand one full turn. As the wheel turns, note any variation on the dial gauge;



CAUTION

Damage to the dial gauge could occur if it strikes a wheel balancing weight.

3. If the variation in lateral run-out exceeds 0.0625 inch (1,6 mm), the wheel must be replaced.

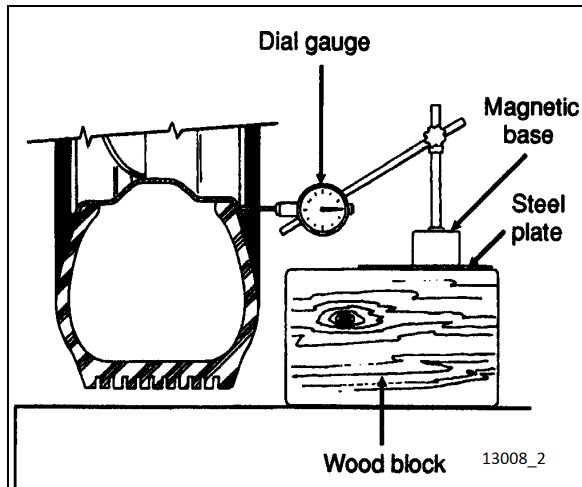

FIGURE 4: DIAL GAUGE INSTALLATION

If doubt exists whether wheel or hub is distorted, hub may be checked as follows:

- Replace the existing wheel with a wheel known to be correct;
- Check wheel lateral run-out as outlined in step 2;
- If, within specifications, the hub is correct but the suspected wheel must be replaced.



WARNING

NEVER STRAIGHTEN ALUMINUM WHEELS. Never heat aluminum wheels to repair damages incurred after hitting a curb or resulting from other causes. The special alloy in wheels has been heat treated, and any uncontrolled heating could alter wheel structure. Furthermore, never weld aluminum-forged wheels for any reason whatsoever.

7. WHEEL STUDS

Stripped threads may be the result of excessive torque or may have been damaged during wheel installation when placing the wheel over the studs. A stud having damaged threads must be replaced. Broken studs are a direct result of operating with loose stud nuts or improperly seated wheels. When a broken stud is replaced, the adjacent studs, on each side of the broken one must also be replaced since they could have been subjected to excessive strain and may be fatigued.

When installing wheel studs to hubs, check nuts retaining the wheel stud to wheel hub and replace if they are deformed, damaged or severely corroded. Install nut (and washer where applicable) to new stud.

TORQUE: 450-500 lb-ft (610-678 Nm)

60 nuts

7.1 DRIVE AXLES WHEEL STUDS

Hub-mounted wheels are mounted with M22x1.5 studs and an M22 flange nut.

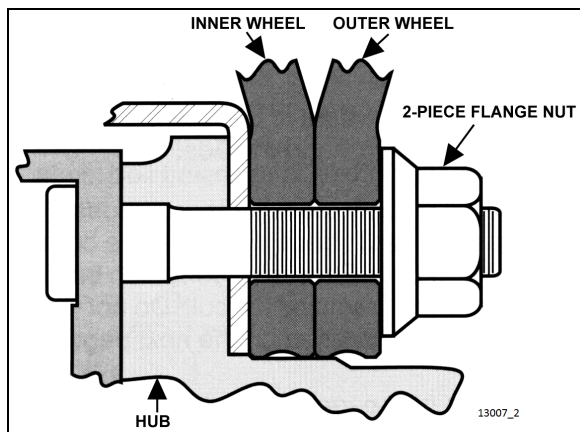

FIGURE 5: DRIVE AXLE WHEELS

7.2 FRONT AND TAG AXLE WHEEL STUDS

Wheel is hub mounted on front and tag axle (M22x1.5 thread).

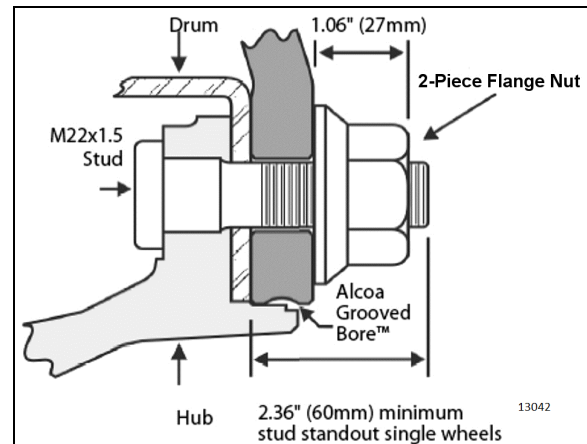

FIGURE 6: SINGLE WHEEL

NOTE

Wheel studs and nuts must be kept free from grease and oil. No lubricant whatsoever should be used.

8. HUB MOUNTED WHEELS

Wheel surfaces in contact with hubs, nuts or other wheels should be kept free of all rust, grease and paint (except for initial “E” coat protection, applied to stop rusting and to facilitate wheel removal). The reason for this is to assure that all faces are clamped together without buildup of any coating. The threads of the wheel studs and the wheel nuts should be clean and undamaged.

NOTE

When painting wheels, make sure to mask all surfaces identified above.

Using a calibrated torque wrench, tighten wheel nuts. Do not use power tools or long bars for tightening. Tighten wheel nuts alternately as shown in FIGURE 3.

TORQUE: 450-500 lb-ft (610-678 Nm)

NOTE

Tightening should not be done immediately after prolonged braking or when wheel ends are hot.

Check wheel nut torque at every 100 miles (160 km) for 500 miles (800 km) after fitting wheels. Let cool before checking. If any relaxation of the initial torque has occurred, retighten. Relaxation of initial torque may occur because of the “bedding down” of the hub and wheel surfaces.

NOTE

Torque relaxation occurs when wheel ends are hot but should revert to original setting when cool. Retightening when hot will produce a higher torque reading than recommended.

8.1 CARE OF WHEELS

Check for cracks in wheels, especially around the fixing holes, studs, nuts and washers. If in doubt, renew.

Do not simply retighten very loose wheel fixings or wheels that are continually becoming loose. Find out why they are loose and whether any damage has been caused.

Use trained personnel and keep records of all attention to wheels and fixings, including which parts were renewed and when.

9. WHEEL HUBS - TAG AXLE

The FAG unitized hub bearings used on the tag axle are non-serviceable items. Bearings are pre-adjusted, lubricated and have seals fitted as part of the manufacturing process. The bearings are greased for life and there is no need or facility for re-lubrication.

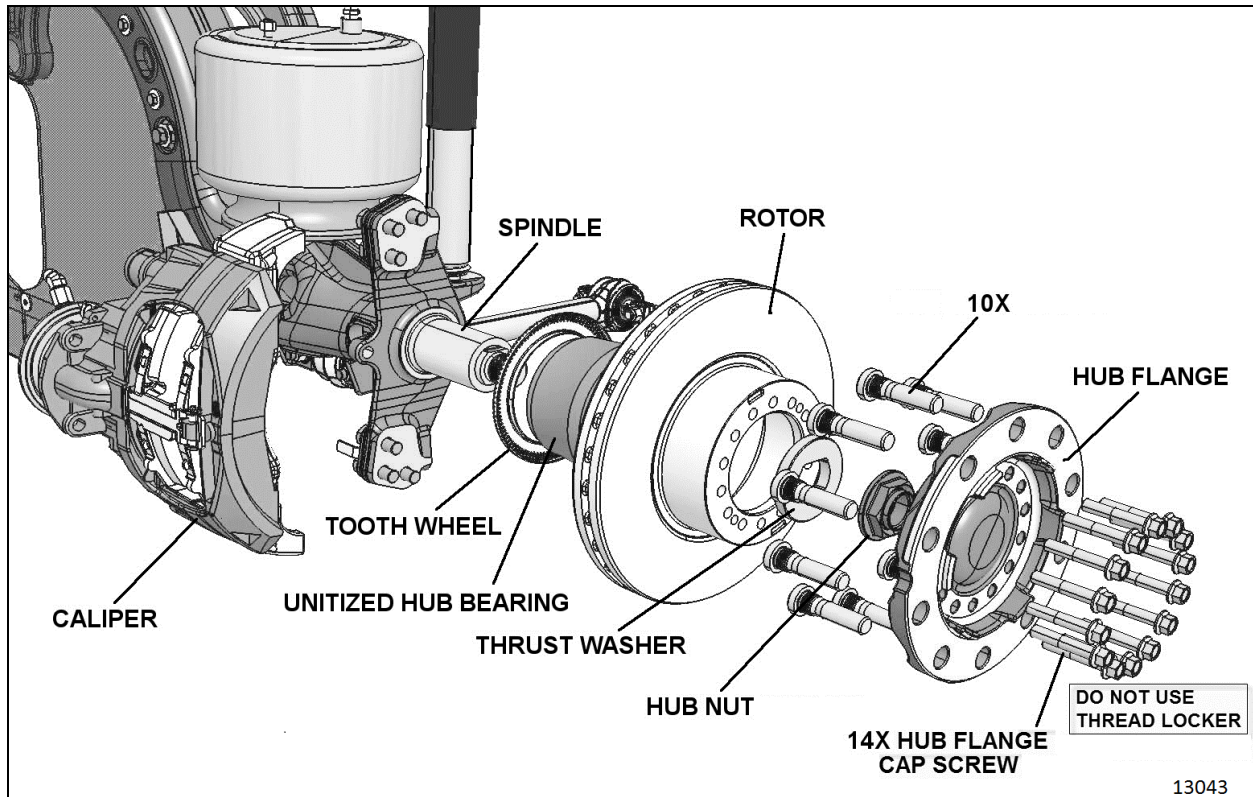

FIGURE 7: TAG AXLE HUB AND ROTOR ASSEMBLY

13043

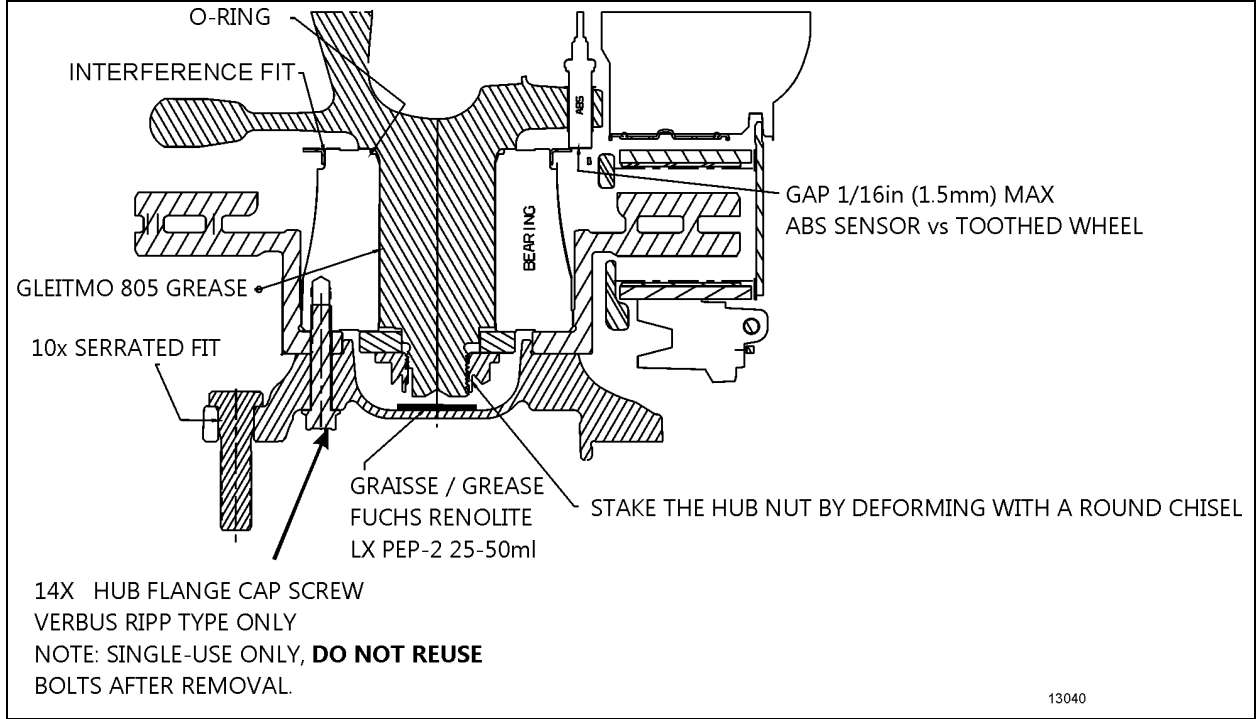

FIGURE 8: TAG AXLE UNITIZED BEARING & WHEEL HUB

9.1 TAG AXLE HUB UNITIZED BEARING INSPECTION

MAINTENANCE

Tag axle unitized bearing

Unitized bearing inspection should be made at the intervals specified by the Lubrication And Servicing Schedule in Section 24: LUBRICATION & SERVICING..

1. Apply parking brake, raise wheels off the ground and support axle on stands.
2. When the wheels are raised, they should revolve quite freely without roughness.
3. Place magnetic base of a dial indicator on brake caliper and position dial indicator stem against a convenient marked spot on face of hub flange.
4. With dial indicator in position pull hard but steadily on hub flange and oscillate at same time until a steady reading is achieved.

5. Without releasing the pressure, turn bearing so that dial indicator stem contacts marked spot and note reading on indicator.
6. Push bearing flange hard and oscillate as before until a steady reading is achieved.
7. Without releasing the pressure, turn bearing so that indicator stem again contacts the marked spot and note new reading on indicator.
8. The difference between readings is the amount of mounted end play in bearing unit.
9. Refer to the following table for allowed end plays:

New Tag Axle Unitized Hub Bearing Axial Endplay	
Maximum axial clearance/end play	0.0024 inch (0.061mm) based on clamp load of 20000 lbf (90 kN).
Tag Axle Unitized Hub Bearing Axial Endplay In Service	
<ul style="list-style-type: none"> If the endplay is between 0 – 0.002 in (0 – 0.05 mm), the inspection is complete. If the endplay is greater than 0.002 in (0.05 mm), but less than <u>0.008 in (0.20mm)</u>, check and retighten the wheel bearing adjusting nut. Again check endplay to make sure that the clamping process is done properly. If the endplay is equal to or greater than 0.008 in (0.20mm), replace the unitized hub bearing as soon as possible since the hub assembly may not be safe to operate. 	

9.2 TAG AXLE HUB BEARING REMOVAL

1. Stop engine and apply parking brake.
2. Loosen wheel nuts about one turn (do not remove the nuts). This is not necessary if equipped with hydraulic powered gun.
3. Raise the vehicle by its jacking points on the body. See Section 18, "Body", under heading "Vehicle Jacking Points".
4. Unscrew 10 wheel hex stud nuts and remove the wheel.
5. Unscrew 14 hub flange hex cap screws.

Applicable to the tag axle: discard hub flange serrated cap screws (single-use only).

NOTE: The following steps are similar to the front axle hub bearing removal procedure. The following images are generic images and do not show the tag axle hub but they remain representative of the following steps.

6. Loosen but do not remove the hub flange bolts.
7. Remove 2 diametrically opposed hub flange bolts.

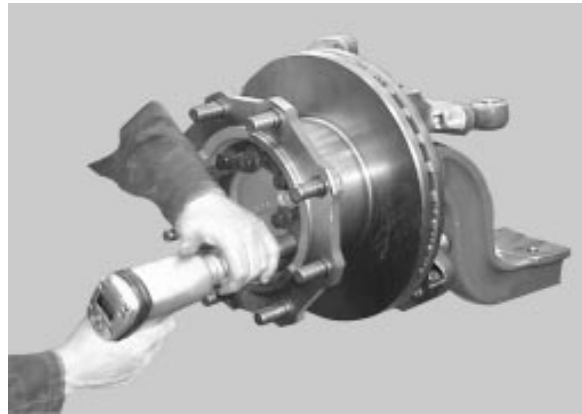

FIGURE 9

8. Replace 2 diametrically opposed hub flange bolts with 2 studs (loosely fitted).

NOTE: Replacement studs should protrude beyond front face of hub flange to aid removal.

9. Gently tap hub flange outwards using a hide faced hammer.
10. Support weight of hub flange and remove hub flange retaining bolts.

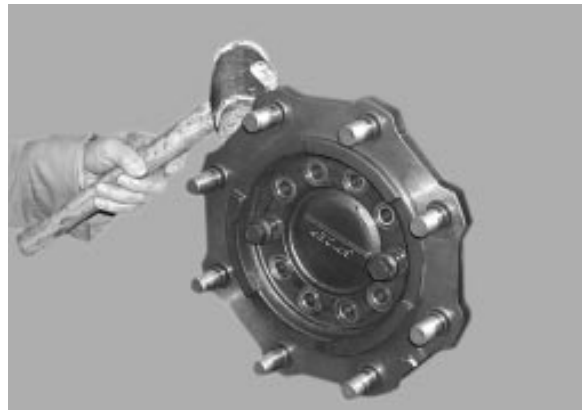

FIGURE 10

11. Remove the hub flange and place on a suitable workbench.
12. Inspect wheel stud and replace the ones that are found defective.
13. Once the hub flange has been removed, insert two bolts into brake disc extraction holes.
14. Tighten to free brake disc from hub bearing.



FIGURE 11

15. Support weight of brake disc and carefully slide along dummy studs to remove.

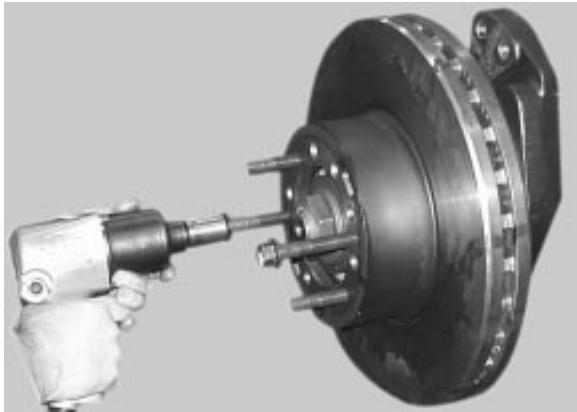

FIGURE 12

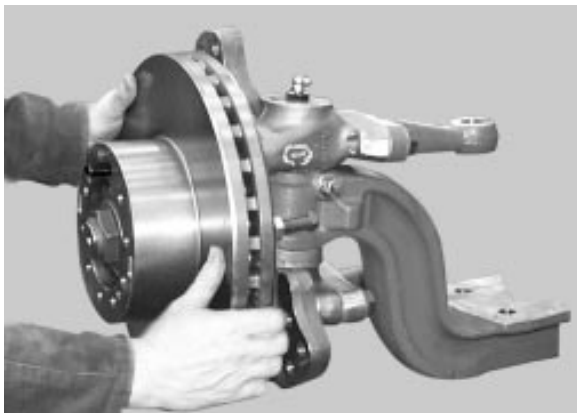

FIGURE 13

16. Using a small ended chisel, pry off the staking on the hub nut.



FIGURE 14

17. Unscrew hub nut and discard.

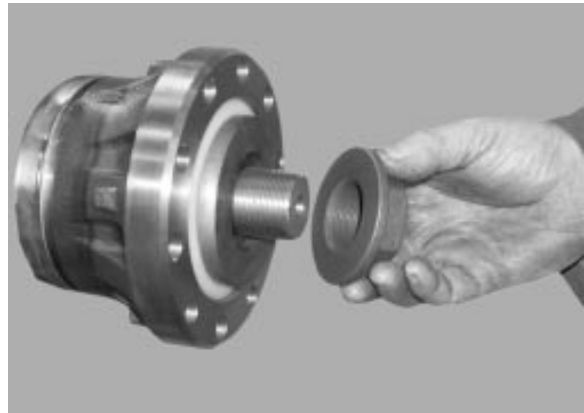

FIGURE 15

18. Remove the thrust washer.



FIGURE 16

19. Screw insertion tool onto spindle (FIGURE 18).

insertion tool tag axle	G32950
insertion tool front axle	491115



FIGURE 17: INSERTION TOOL

20. Carefully pull unitized bearing assembly and remove.

9.3 TAG AXLE HUB BEARING INSTALLATION

1. Clean spindle using EFX degreaser (Prevost #685313) or brake cleaner.
2. Screw insertion tool onto spindle (FIGURE 18).

insertion tool tag axle	G32950
insertion tool front axle	491115



FIGURE 18: INSERTION TOOL

3. Apply a thin layer of antifriction/antifretting lubricant on spindle where bearing will be located (use Gleitmo 805 grease, Prevost #685274).



FIGURE 19: APPLY GLEITMO 805 GREASE

4. Slip unitized hub bearing over spindle.
5. Make sure the O-ring is present, see Figure 8.

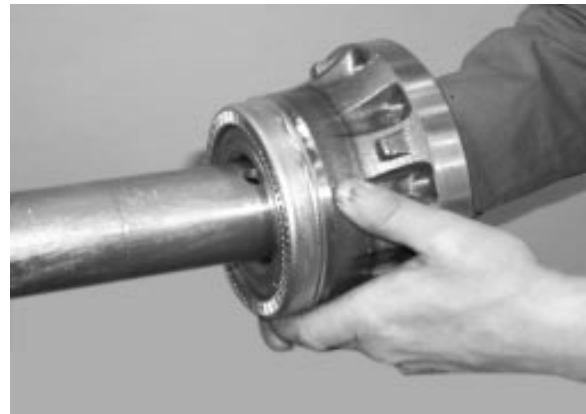

FIGURE 20: SLIP UNITIZED HUB BEARING OVER SPINDLE

NOTE

If the inner rings are not properly guided (i.e. not in line to spindle) there may occur a seizing between inner ring and spindle before the assembly be completed. By pushing abruptly the hub unit back, there is a risk of separation of inner rings. The clip can be dislodged as per the two pictures below.

Always use an insertion tool



6. Remove the insertion tool.
7. Clean thrust washer both sides and hub nut using a good quality degreaser or brake cleaner.
8. Install thrust washer, hub nut then torque hub nut.

Refer to Torque Table

NOTE: Rotate bearing, minimum 10 revolutions necessary (simultaneous rotation till final clamp torque is achieved).

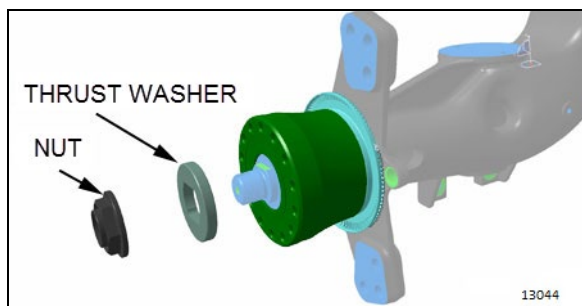

FIGURE 21: INSTALL THRUST WASHER AND HUB NUT

9. Make sure there is no play between the bearing and the spindle shoulder.

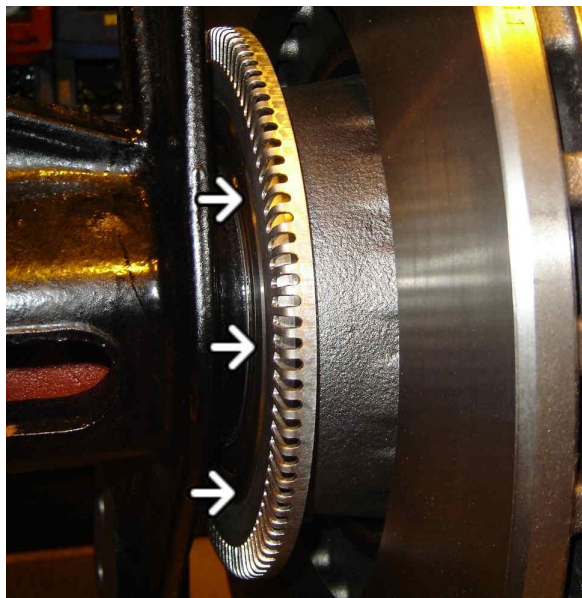

FIGURE 22: NO PLAY BETWEEN THE BEARING AND THE SPINDLE SHOULDER

10. Check the unitized bearing end play. Refer to paragraph 9.1 *Tag Axle Bearing Inspection*.
11. Stake the hub nut by deforming with a round nosed chisel.

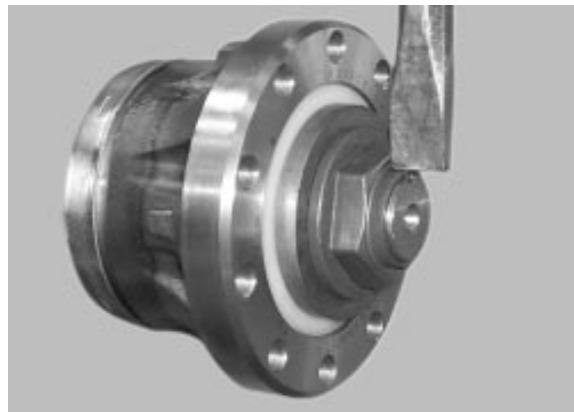

FIGURE 23



FIGURE 24: CORRECT - PREVENTS THE NUT FROM GETTING LOOSE

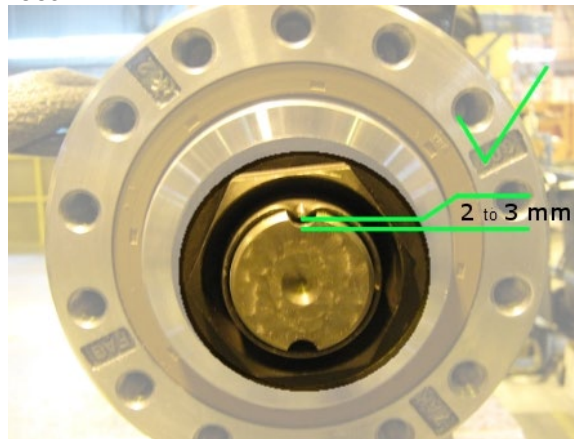

FIGURE 25: CORRECT – 2 TO 3 MM / 0.078 TO 0.118 IN



FIGURE 26: BROCKEN OR TORN LIP – REJECTED

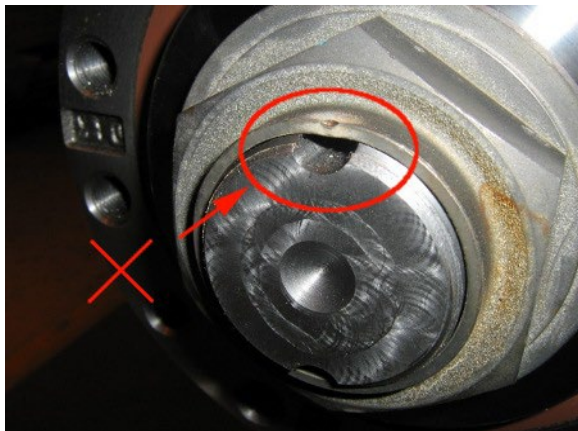

FIGURE 27: LIP INADEQUATELY PRESSED IN – REJECTED

12. Clean hub bearing, rotor and hub flange clamping surfaces using a good quality degreaser or brake cleaner.

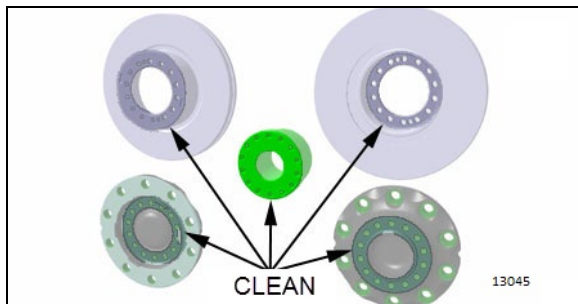

FIGURE 28: CLEANING HUB BEARING, ROTOR AND HUB FLANGE CLAMPING SURFACES

13. Install two guide studs on the unitized bearing.

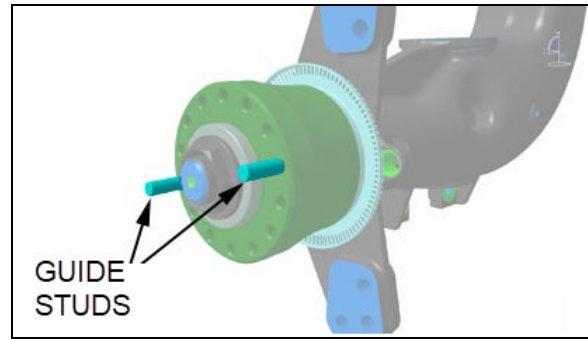

FIGURE 29

14. Install rotor onto hub bearing.

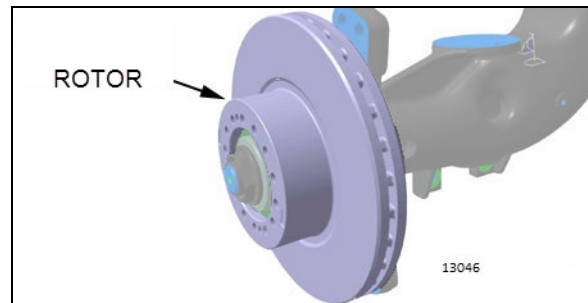

FIGURE 30: ROTOR

15. Add some grease (25-50 ml) (Fuchs Renolite LX PEP-2) (Prevost #685325) into the bottom of the hub flange cap. Mount hub flange onto rotor.

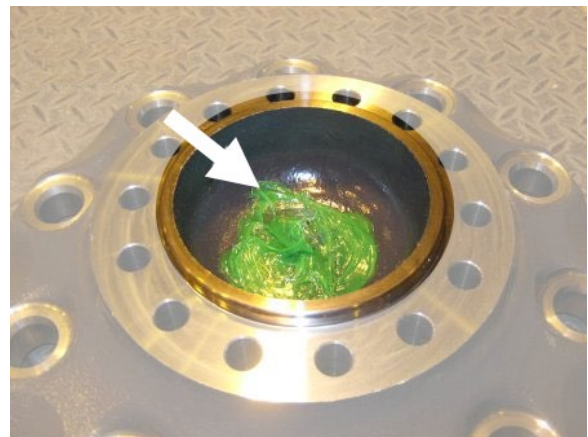

FIGURE 31

16. Secure hub flange and rotor to unitized hub bearing using 14 new cap screws (single-use only). Refer to FIGURE 33 for tightening sequence.

Refer to Torque Table

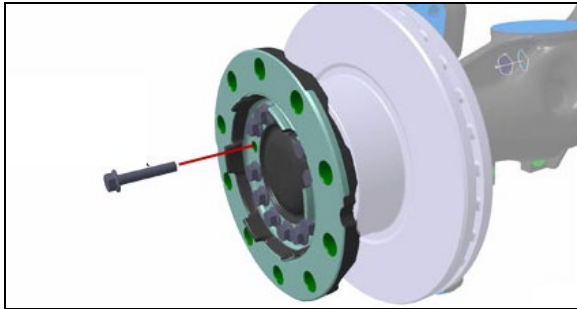

FIGURE 32: HUB FLANGE HEX CAP SCREW

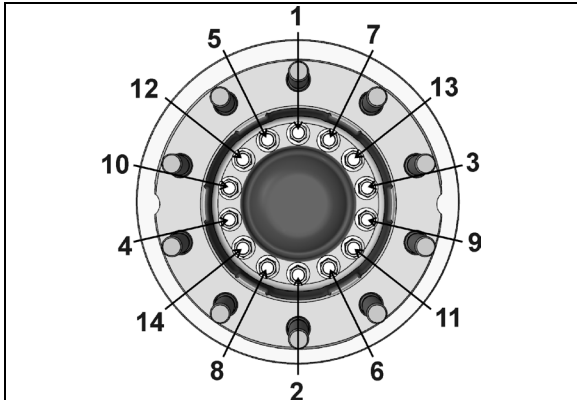

FIGURE 33: HUB FLANGE HEX CAP SCREW TIGHTENING SEQUENCE

17. Once the hub flange has been correctly fitted; it is necessary to check the axial run out of the brake disc.

18. Position a dial test indicator onto the axle in a suitable position.

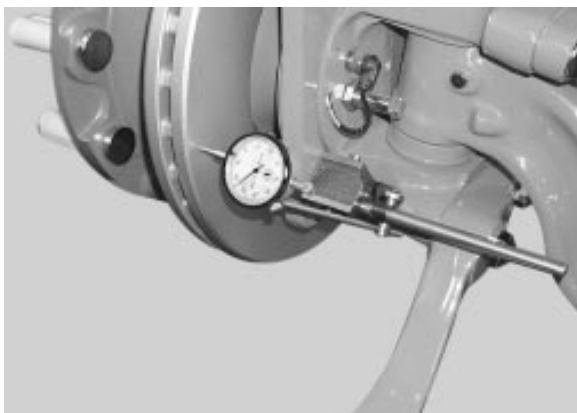

FIGURE 34

19. Position the stylus of dial test indicator onto brake disc as shown.

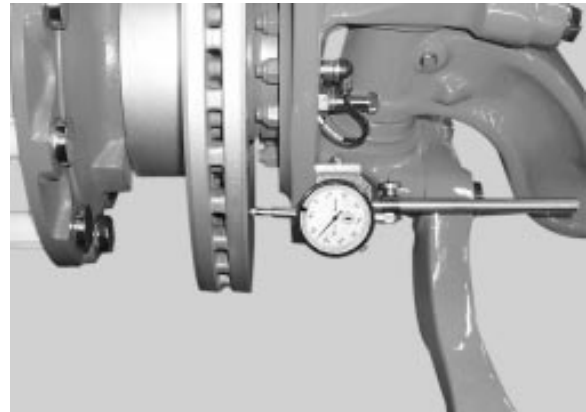

FIGURE 35

20. Rotate the hub through 360° and note any movement of the dial test indicator.

THE MAXIMUM RUNOUT IS 0.1 mm / 0.004 in

21. Remove and check out of specification disc to ensure no damage has occurred to the mounting faces, or that no dirt is present.

22. Remove any dirt found on the mounting faces and refit and re check disc.

23. Should it be found that a cleaned and refitted disc is still out of specification; it must be replaced.

24. Mount the brake caliper. Refer to Knorr Bremse manual.

25. Mount the wheel over studs, being careful not to damage stud threads.

26. Screw in the hex stud nuts (refer to FIGURE 3 for sequence) so that wheel will position itself concentrically with hub. This is important, otherwise wheel may be eccentric with hub and will not run straight. In this initial step, slightly tighten the nuts to correctly position the wheel.

27. Tighten stud nuts progressively as shown in Figure 3. The final tightening should be done with a torque wrench. Tighten stud nuts to prescribed torque.

10. WHEEL HUB - INDEPENDENT FRONT SUSPENSION (NEW IFS DESIGN)

D78: Designation for the hub. Refers to the outer diameter of the spindle / inner diameter of the wheel bearing. The D78 hub is equipped with 434 mm disc.

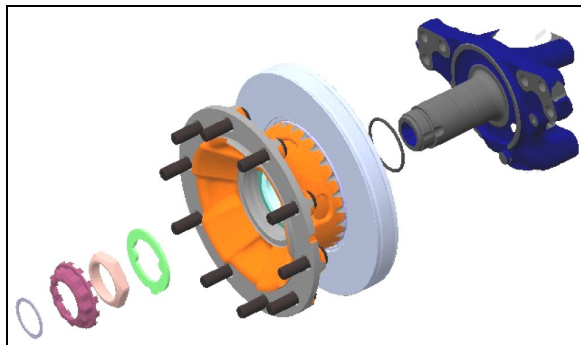

FIGURE 36: HUB INSTALLATION WITH THRUST WASHER, HUB NUT (HEXAGON), LOCK WASHER, RETAINING RING AND STEERING KNUCKLE. NOTE: THE VISUAL REPRESENTATION OF THE STEERING KNUCKLE ON THE IMAGE DIFFERS FROM THE ACTUAL STEERING KNUCKLE ON THIS IFS

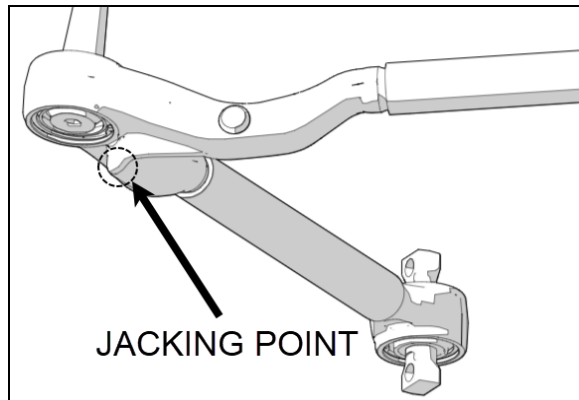

FIGURE 37

10.1 NEW IFS DESIGN HUB REMOVAL

WARNING

Ensure the air is drained from the air suspension system anytime a vehicle is raised off the ground from under the tires for service.

WARNING

A raised vehicle which has not been properly secured can cause serious damage.

- Only use jack stands with adequate rating.
- Verify that jacks and jack stands are fault-free.
- DO NOT work under or around a vehicle until it is supported on jack stands.

1. Read the warnings above.
2. Raise the vehicle.
3. Using appropriate jack stands, support both IFS lower control arms at the jacking points.

CAUTION

NEVER USE THE BACKBONE AS LIFTING POINT

4. Remove the wheel nut caps.
5. Remove the wheel nuts.

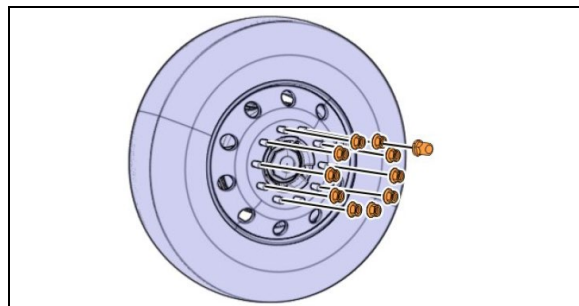

FIGURE 38

6. Remove the wheel.
7. On the brake caliper, turn the adjuster counterclockwise (A) to increase the play until you feel the adjuster stem stop. Increasing play requires more force than adjustment. Do not exceed 30 lb-ft (40 Nm) in either direction.

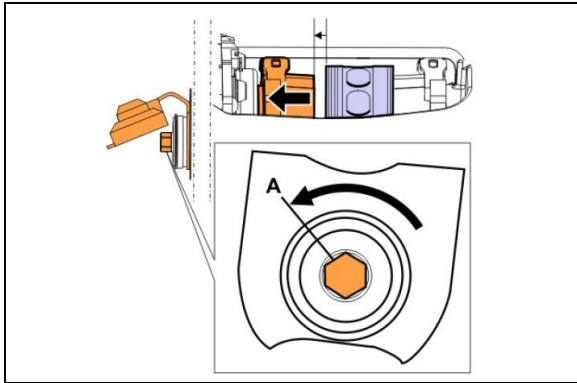

FIGURE 39

8. Remove the ABS sensor harness cable ties. Mark the cable ties positions.
9. Remove the ABS sensor and other sensor installed.
10. Remove the caliper. To do so, refer to **Brake Caliper Removal & Installation (Wheel Removed)** in Section 12 BRAKE AND AIR SYSTEM.

**CAUTION**

Always cover the air chamber opening on the caliper with tape to prevent debris from entering the caliper housing. Debris or other contaminants can cause damage to the caliper.

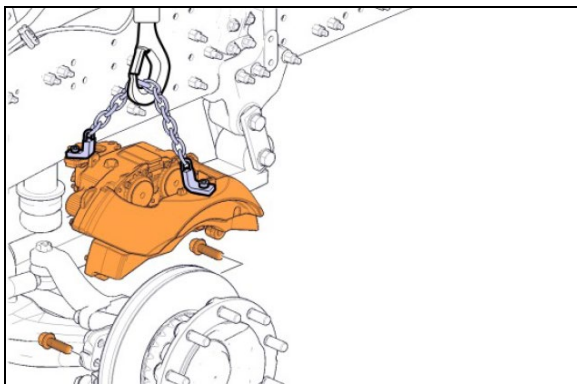

FIGURE 40

11. Support the hub using a trolley jack (A) and ideally, a hub lifting tool (B).

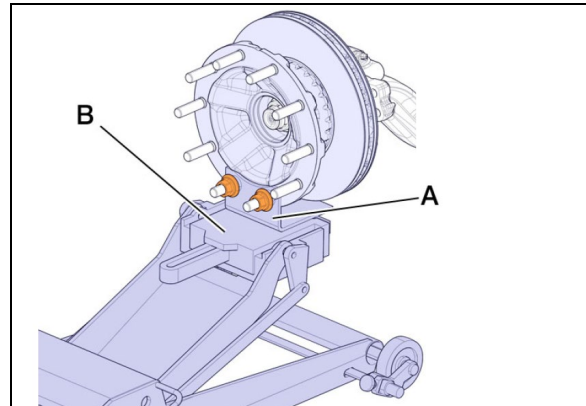

FIGURE 41

12. Remove the hub cap.
13. Remove the retaining ring.
14. Remove the lock.

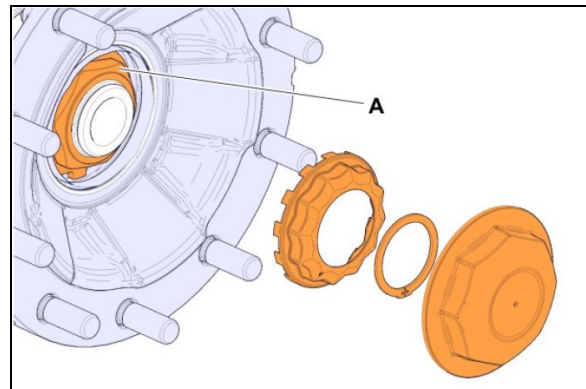

FIGURE 42: (A) HUB NUT

15. Remove the hub nut (A) and the thrust washer. Discard the hub nut.
16. Remove the hub.

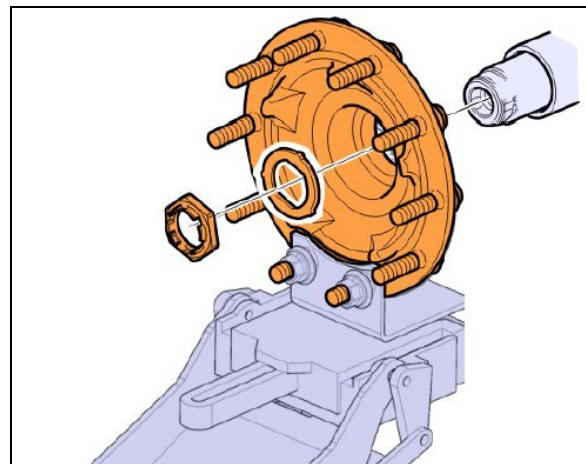

FIGURE 43

10.2 NEW IFS DESIGN HUB INSTALLATION

1. Inspect the ABS sensor wheel.
2. Carefully clean the spindle.
3. Apply an even layer of lubricant on the spindle. Make sure it covers the full revolution.

Requirement: The lubricant must cover the surface that supports the installed bearing.

NOTE: Avoid lubricant on the spindle threads. The lubricated spindle must be adequately protected from contaminants during reassembly.

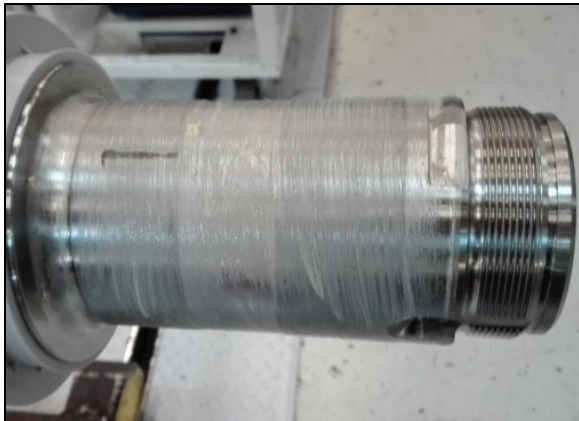

FIGURE 44

4. Install the hub onto the spindle.

Do not force the hub when inserting in order to avoid damage to the gaskets.

The axial seal shall be in the correct position on the bearing according to the figure below and shall not be damaged during the mounting of the hub onto the spindle.

During the mounting of the hub take care that the sensor wheel is not clashing against the spindle or other adjacent parts.

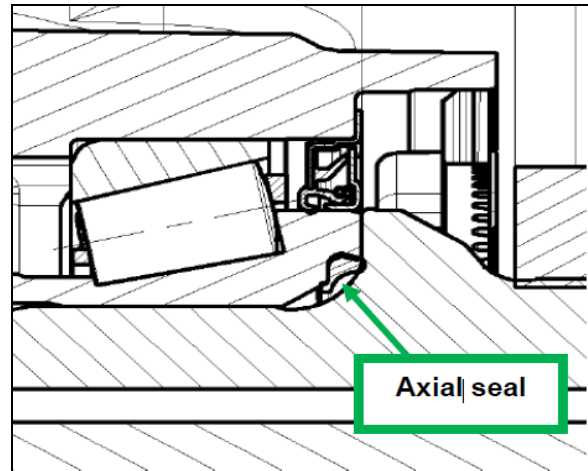

FIGURE 45

5. After ensuring the hub is seated properly, install the thrust washer. Ensure that the thrust washer is guided by the two grooves until fully in contact with the hub bearing.

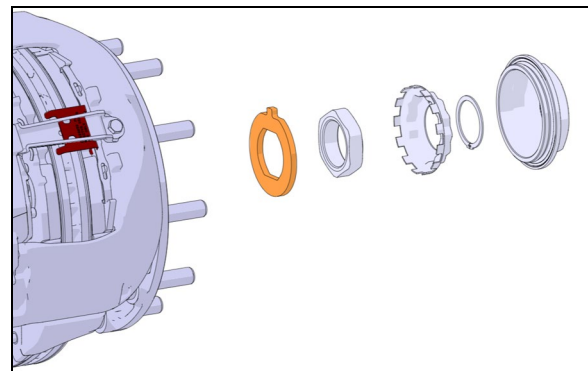

FIGURE 46

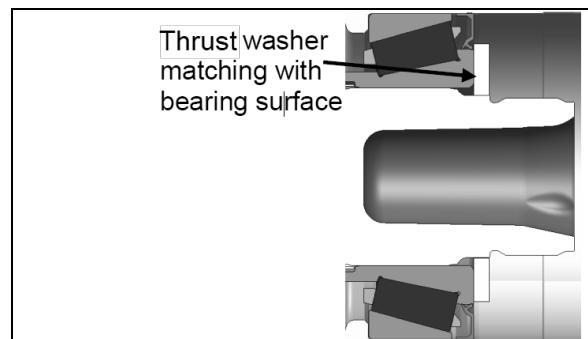

FIGURE 47

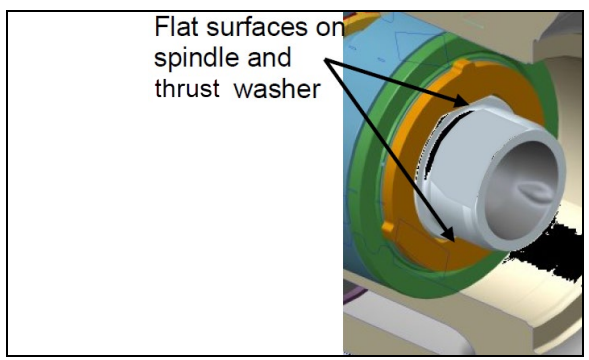

FIGURE 48: THE FLAT SURFACE ON THE THRUST WASHER MUST MATCH WITH THE FLAT SURFACE ON THE SPINDLE

- 6. Visually check the threads on spindle and hub nut (hexagon) for apparent damages.
- 7. Screw in a new hub nut by hand as far as possible. Ensure that the thrust washer is in the correct position.

CAUTION
 The hub nut is not allowed to be reused.

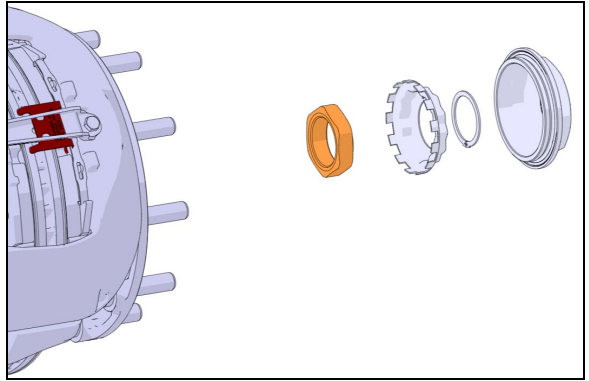

FIGURE 49

- 8. Install the hub nut tool (A).

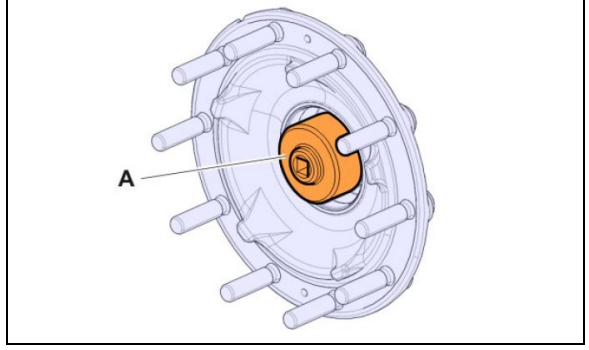

FIGURE 50: (A) HUB NUT TOOL

- 9. **Pre-tightening steps.** See Torque Table.

- 10. **Final tightening steps.** See Torque Table.
- 11. Secure the hexagon nut with the lock washer and retaining ring. Ensure that the retaining ring is correctly positioned in the groove.

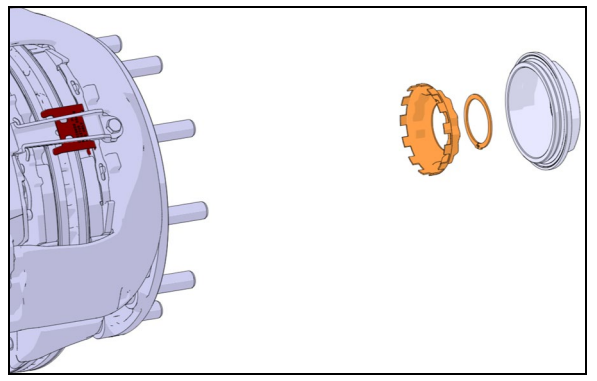

FIGURE 51

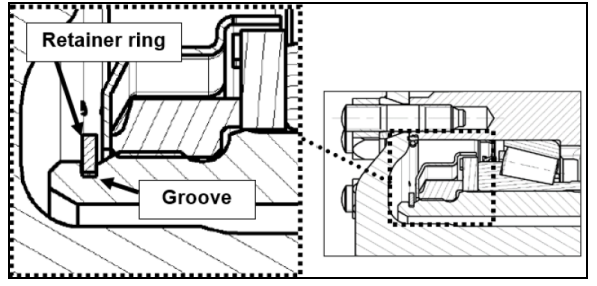

FIGURE 52: RETAINER RING IN POSITION

NOTE: The inspection hole on the lock washer can be used with a gauge to ensure the presence of the hub nut (hexagon).

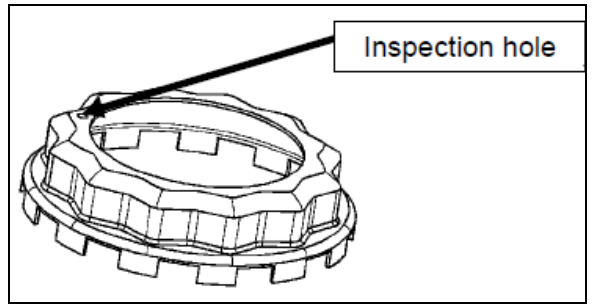

FIGURE 53

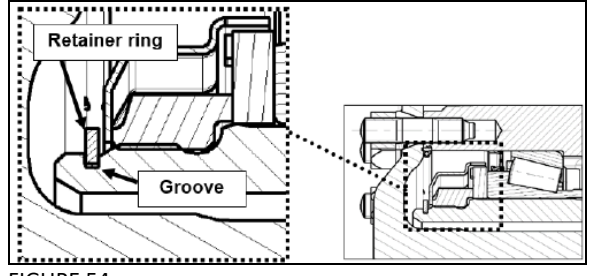

FIGURE 54

- 12. Install the hub cap with a **new gasket**. Check the O-ring is in the right position. Lubricate

with Vaseline to reduce the friction on the green marked area. Remark: Lubricant on the hub cap thread area (marked red) must be avoided.

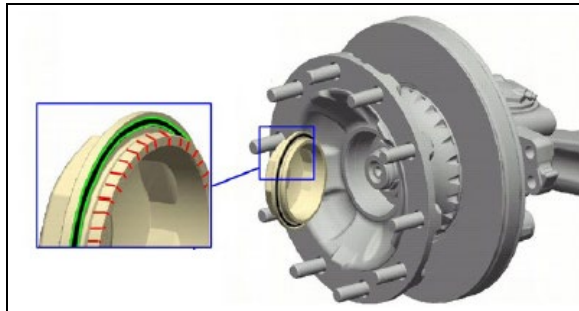

FIGURE 55

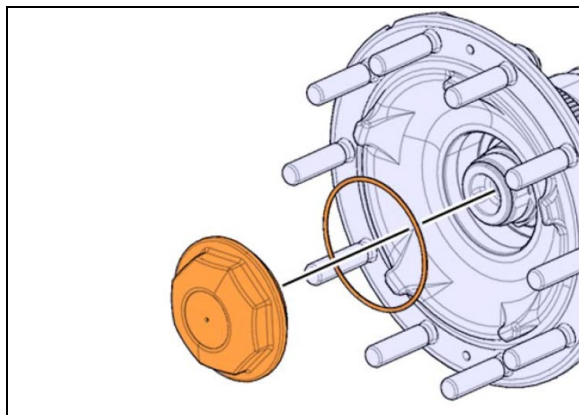

FIGURE 56

13. Tighten the hub cap.
14. Reinstall the ABS sensor. Apply universal grease on the sensor.
15. Press the sensor & guide sleeve into position until it comes into contact with the sensor wheel. Check that the sensor is securely in place.
16. Replace the guide sleeve if the sensor is loose.

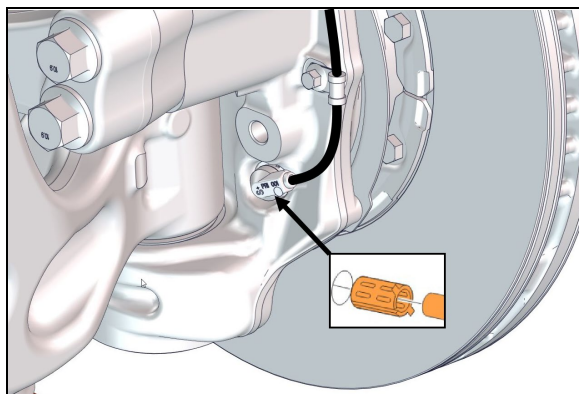

FIGURE 57

17. Reinstall any other sensor previously removed.
18. Reinstall the brake caliper, the brake pads and the brake chamber. To do so, refer to **Brake Caliper Removal & Installation (Wheel Removed)** in Section 12 BRAKE AND AIR SYSTEM. You can also refer to MERITOR EX Air Disc Brake Maintenance Manual MM-0467 available on Prevost Technical Publications site.
19. On the brake caliper, turn the adjuster clockwise (A) to reduce the play. Do not exceed 30 lb-ft (40 Nm) in either direction.

The brake pads must touch the disc, but the hub must still be easy to turn by hand.

Turn the adjustment screw counterclockwise (B) about one-half turn to achieve the correct play.

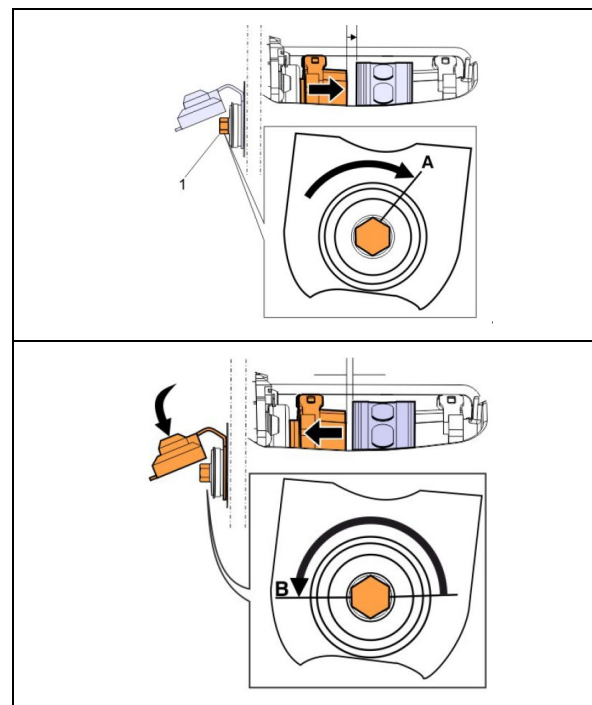

FIGURE 58

20. Apply the brakes several times.
21. Make sure that the hubs rotate freely.
22. Install the wheel.
23. Install the wheel nuts and tighten but not to prescribed torque yet.

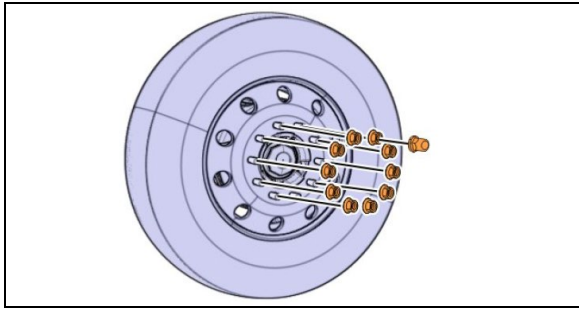

FIGURE 59

24. Ensure that the parking brake is applied. Remove the jack stands and lower the vehicle.
25. Tighten the wheel nuts to prescribed torque.

10.3 NEW IFS DESIGN UNIT-BEARING INSPECTION

NOTE: Illustrations may differ from the actual vehicle being serviced. However, key components addressed in this information are represented as accurately as possible.

NOTE: The Unit-bearing is grease lubricated at the factory and does not need re-lubricating.

1. Remove the hub caps with hand tools.
Note: Using power tools could damage the cap.

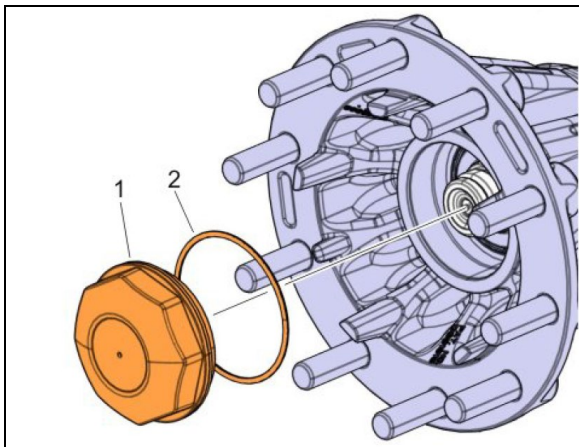

FIGURE 60: (1) HUB CAP, (2) O-RING

2. Inspect O-ring for moisture / contaminant intrusion witness marks.
Note: Always use a new O-ring when installing the cap.
Note: Replace cap and O-ring if evidence of contaminant intrusion is seen.

3. Remove the retaining ring and lock washer.

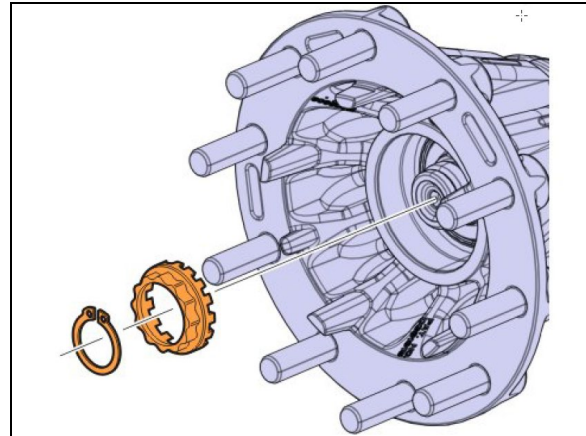

FIGURE 61

4. Inspect hub barrel for evidence of grease. If grease is found, replace the bearing.

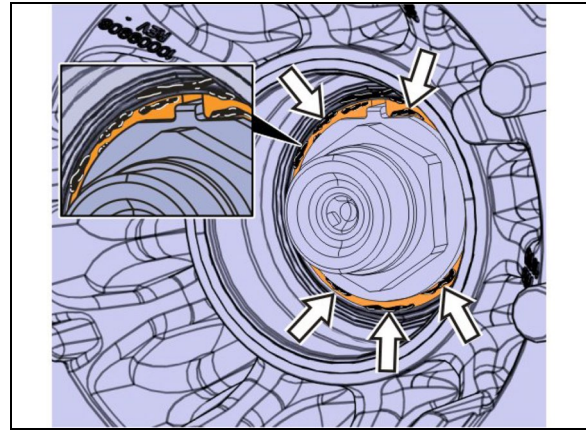

FIGURE 62

5. If no grease is found raise the steer axle with both tires off the ground.
6. Check the front wheel bearings with a wheel spinner and listen to the bearings during rotation. After the tire/wheel are removed, it may be necessary to rotate the hub by manual means.

Note: Rotation speed of 50 rpm (82 rpm maximum) is recommended.

Note: Abnormal noise in the bearings is a sign of bearing wear. Hubs with worn bearings should therefore be replaced to avoid damage to the wheel end.

7. Check the play on the front wheel bearings by using a bar as a lever to lift and a dial indicator. The bearings should normally be pre-tensioned and there should not be any play in the bearings. Do not confuse play in

the wheel bearings with play in the king pin bearings.

Note: If there is play in the bearing, the bearing should be replaced.

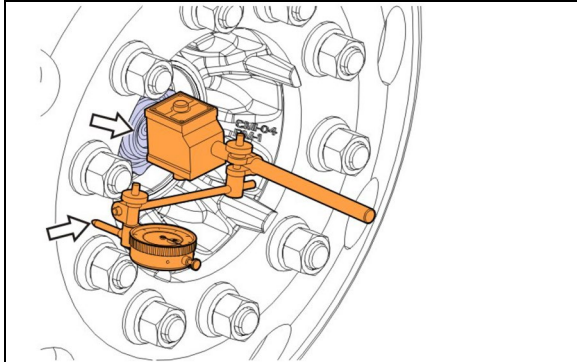

FIGURE 63

10.4 NEW IFS DESIGN UNIT-BEARING REPLACEMENT (HUB REMOVED)

NOTE: Illustrations may differ from the actual vehicle being serviced. However, key components addressed in this information are represented as accurately as possible.

1. Position the hub on a flat surface.
2. Remove the retaining ring (1).

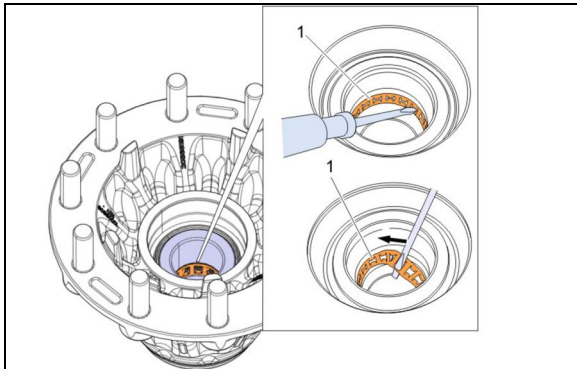

FIGURE 64

3. Remove the bearing.

NOTE: Use a hammer and brass drift.

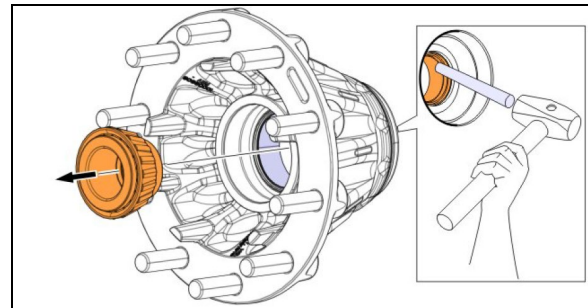

FIGURE 65

4. Turn the hub.
5. Remove the bearing and the seal.

NOTE: Use a hammer and brass drift.

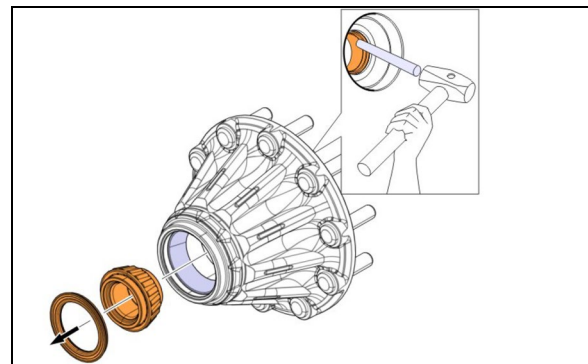

FIGURE 66

6. Confirm the inner diameter of the old bearing is 78 mm.

NOTE: Use a sliding caliper.

7. For the inner diameter of the bearing of 78 mm: Use the tools for the D78 hub.
8. Position the hub on the hydraulic press.
9. Install the tools.
10. Remove the bearing race. Bearing race, minimum extraction pressure (≥ 0.55 ton US).

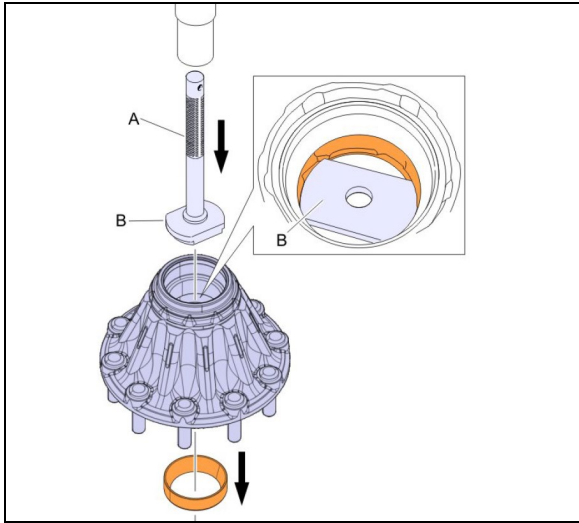

FIGURE 67: (A) HANDLE, (B) D78 DRIFT

11. If the press force is less than the specification, replace the hub.
12. Clean the hub.
13. Inspect the hub for wear or damage. Inspect the bearing race areas for signs that the race has rotated in the hub.
14. Replace the hub if it is worn or damaged.
15. Position the hub on the hydraulic press.
16. Install the retaining ring along with the outer bearing. Use new parts. Use the bearing marked with OUTBOARD.

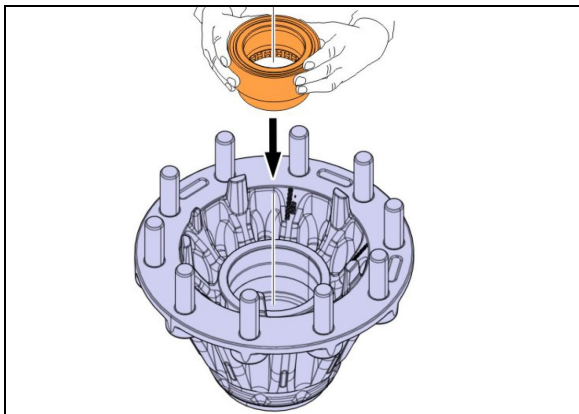

FIGURE 68

17. This step contains 2 alternatives. Select one of the valid alternatives below.

ALTERNATIVE 1

18. Position the tools.
19. Press the bearing. Bearing race, maximum press-fit pressure (≤ 4.4 ton US).

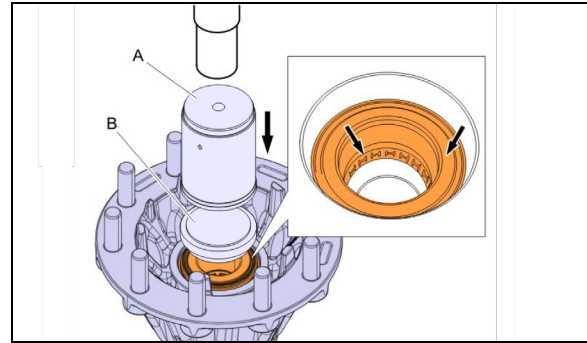

FIGURE 69: (A) HOLLOW DRIFT, (B) D78 DRIFT

ALTERNATIVE 2

20. Position the tools.
21. Thread the puller tool screw (A) by hand until it stops.
22. Press the bearing into the hub. Use an appropriate tool.

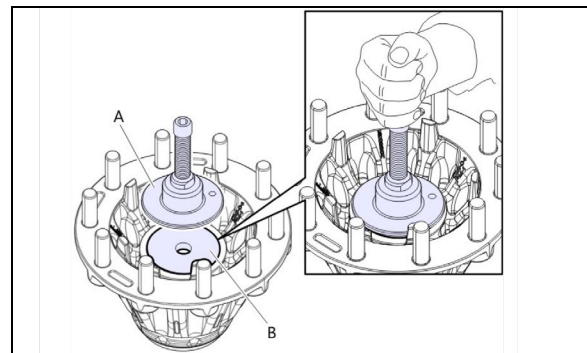

FIGURE 70: (A) D78 PULLER, (B) DRIFT

23. Turn the hub.
24. Install the inner bearing. Use a new part. Use the bearing marked with INBOARD.

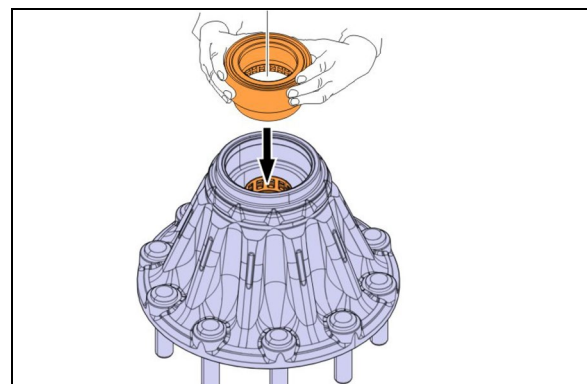

FIGURE 71

25. Position the tools.
26. Press the bearing. Bearing race, maximum press-fit pressure (≤ 4.4 ton US).

NOTE: A clicking sound will be heard when the inner bearing locks against the outer bearing.

NOTE: Ensure that the bearings are locked correctly.

NOTE: The retaining ring will rotate freely if the bearings are locked correctly.

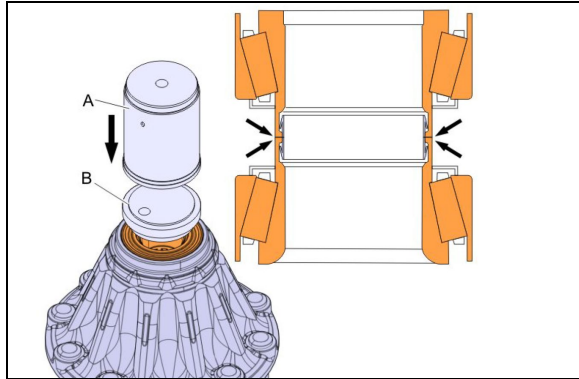

FIGURE 72: (A) HOLLOW DRIFT, (B) D78 DRIFT

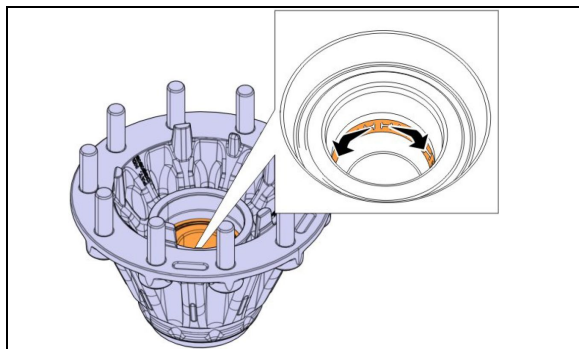

FIGURE 73

27. If the locking ring does not rotate freely, install the tool, press the bearing.

Bearing race, maximum press-fit pressure (≤ 4.4 ton US)

NOTE: A clicking sound will be heard when the inner bearing locks against the outer bearing.

NOTE: Ensure that the bearings are locked correctly.

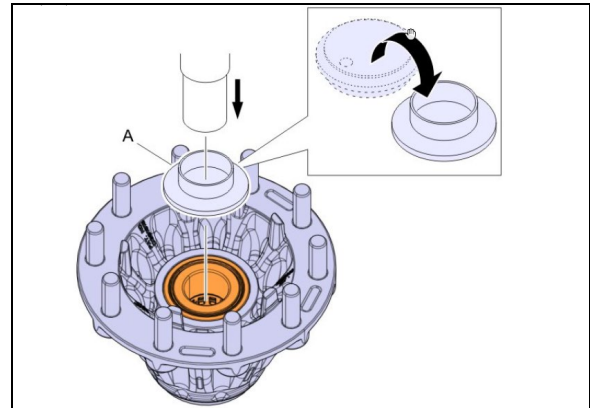

FIGURE 74: (A) D78 DRIFT

28. Install the seal.

NOTE: Use a new part

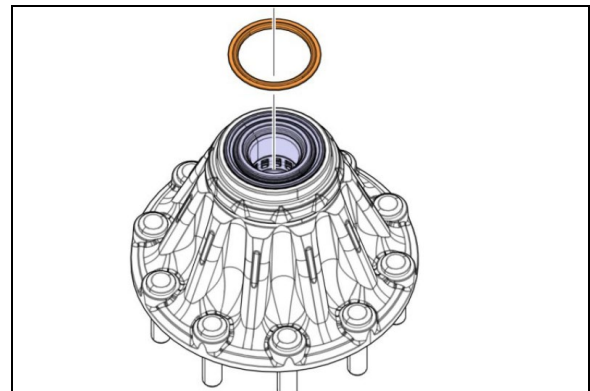

FIGURE 75

11. WHEEL HUBS - FRONT AXLE

Applicable to I-beam axle and previous IFS design.

The FAG unitized hub bearings used on the NDS range of axles, are non-serviceable items. Bearings are pre-adjusted, lubricated and have seals fitted as part of the manufacturing process. The bearings are greased for life and there is no need or facility for re-lubrication.

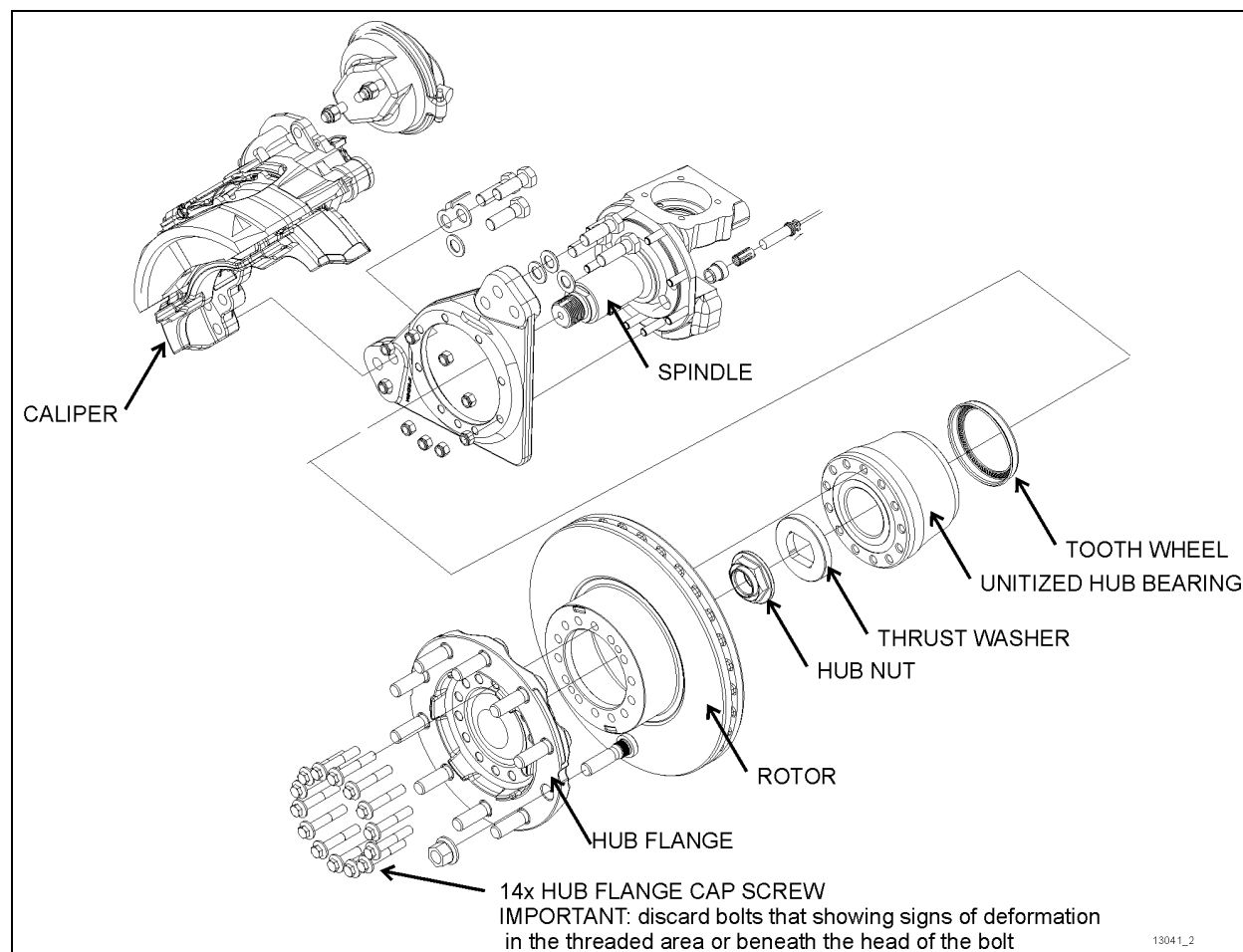

FIGURE 76: FRONT AXLE HUB AND ROTOR ASSEMBLY

11.1 FRONT AXLE HUB BEARING INSPECTION



MAINTENANCE

Front axle unitized bearing

Unitized bearing inspection should be made at the intervals specified by the Lubrication And Servicing Schedule in Section 24: LUBRICATION & SERVICING.

1. The front axle hub bearing inspection procedure is similar to the tag axle hub bearing inspection. Refer to 9.1 *tag axle Hub unitized Bearing Inspection*.

The mounted Unitized hub bearing axial endplay should not exceed:

- **0.050 mm (0.002")** for a new bearing,
- **0.20 mm (0.008")** for a bearing which has been in service.

NOTE

If original bearing unit is re-fitted, and end-float is measured at 1 mm, with hub not fully tightened to specified torque, then the retaining clip within the unit is damaged and a new unit must be fitted.

11.2 FRONT AXLE HUB BEARING REMOVAL

The front axle hub bearing removal procedure is similar to the tag axle hub bearing removal. Refer to 9.2 *tag axle HUB BEARING REMOVAL*.

You can also find detailed information on front axle wheel hub bearing removal, refer to the following manual included on your vehicle Technical Publications USB flash drive in PDF format:

Dana Parts & Service Instructions S84U Steer Axle HUB BEARING REWORK_ Manual NO 1963 A+B iss A.

See OVERHAUL PROCEDURES, HUB END DISASSEMBLY, pages No. B3, B4, B5 & B6.



CAUTION

NEVER USE THE CENTRAL BEAM AS LIFTING POINT ON THE INDEPENDENT SUSPENSION

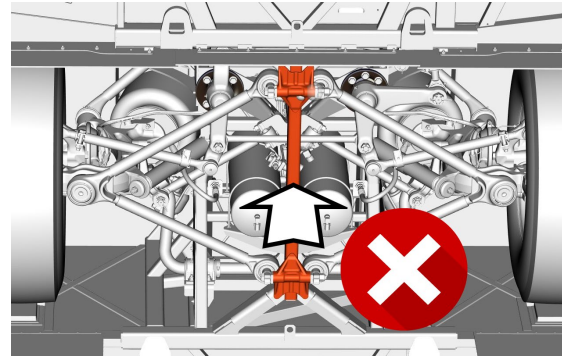

11.3 FRONT AXLE HUB BEARING INSTALLATION

The front axle hub bearing installation procedure is similar to the tag axle hub bearing installation. Refer to 9.3 *tag axle HUB BEARING INSTALLATION*.

You can also find detailed information on front axle wheel hub bearing removal, refer to the following manual included on your vehicle Technical Publications USB flash drive in PDF format:

Dana Parts & Service Instructions S84U Steer Axle HUB BEARING REWORK_ Manual NO 1963 A+B iss A.

See OVERHAUL PROCEDURES, HUB END REASSEMBLY, pages No. B23 up to B30.

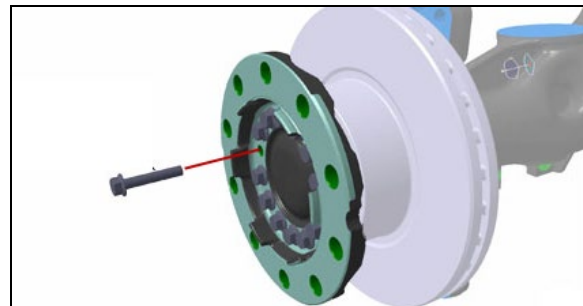

FIGURE 77: HUB FLANGE HEX CAP SCREW

Secure hub flange and rotor to unitized hub bearing using 14 hub flange cap screws. Refer to FIGURE 78 for tightening sequence.

TORQUE: 174-192 lb-ft (236-260 Nm)

NOTE: discard bolts that start to show signs of deformation in the threaded area or beneath the head of the bolt.

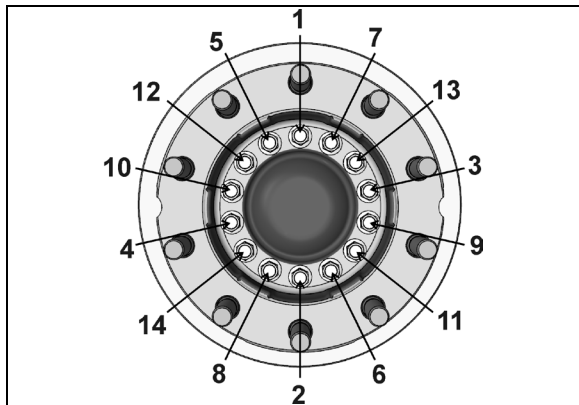

FIGURE 78: HUB FLANGE HEX CAP SCREW TIGHTENING SEQUENCE

12. MERITOR DRIVE AXLE WHEEL HUBS

Drive wheels use a single oil-seal assembly. They are lubricated from the oil supply in the differential housing. Bearings are tapered rollers, adjustable to compensate wear. Maintain differential oil level with general-purpose gear lubricant (refer to Section 24 "Lubrication" for proper oil grade selection) to ensure adequate oil supply to wheel bearings at all times.

Additional information is found in the following manuals, included on your vehicle Technical Publications USB flash drive:

- *Meritor Maintenance Manual 23A – Bus and Coach Rear Drive Axles*
- *Meritor Maintenance Manual 5A – single reduction differential carriers*

12.1 BEARING CHECK/ADJUSTMENT

To adjust drive wheel bearings, refer to "Adjustment – Wheel bearings" heading in Meritor Maintenance Manual 23A – Bus and Coach Rear Drive Axles.



MAINTENANCE

Drive axle bearing end play

Check drive axle bearing end play at the intervals specified by the Lubrication And Servicing Schedule in Section 24: LUBRICATION & SERVICING..

Refer to "Adjustment – Wheel bearings" heading in Meritor Maintenance Manual 23A – Bus and Coach Rear Drive Axles.

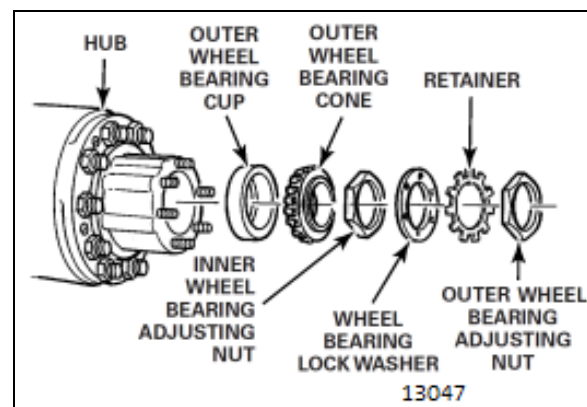

FIGURE 79: DRIVE AXLE WHEEL HUB

12.2 DISASSEMBLY AND REPAIR

Additional information is found in the following manual:

- **Meritor Maintenance Manual 23A – Bus and Coach Rear Drive Axles**

1. Jack vehicle and remove axle shaft as indicated in "Meritor - Maintenance Manual No. 23A.
2. Remove wheels and tires.

NOTE

It is good practice to mark position of the wheel on the axle before removal and replace wheel at the same position during reinstallation.

3. Remove lock nut, lock ring and adjusting nut from axle housing to prevent the outer bearing from falling out. Remove outer bearing cone and roller assembly.
4. Remove screws attaching inner oil seal retainer to hub, and remove inner oil seal assembly. Remove inner bearing cone and roller assembly. Bearing cups can be separated from the hub using a hammer and a long brass drift.
5. Thoroughly clean all parts. Bearing cone and roller assemblies can be cleaned in a suitable cleaning solvent using a stiff brush to remove old lubricant.
6. In case that excessive wear, deterioration, cracking or pitting is present on the bearing cups, rollers or cones, the bearings should be replaced. Seals should be replaced each time they are removed from the hub. To install new oil seal, use a suitable adapter and drive the seal into the retainer bore until it bottoms.
7. When installing wheel on spindle, center the wheel hub with spindle to avoid damaging the seal with the end of the spindle. Push wheel straight over the spindle until inside diameter of seal press fits on wiper ring. Fill hub cavity with general-purpose gear lubricant (refer to Section 24 "Lubrication" for proper oil grade selection). Lubricate, then install outer bearing cone. Adjust bearing and lock.

8. Assemble axle flange to axle using a new gasket. Apply sealant in stud area. After both wheels have been assembled according to above procedure, fill the differential with the recommended lubricant to the proper factory recommended level.

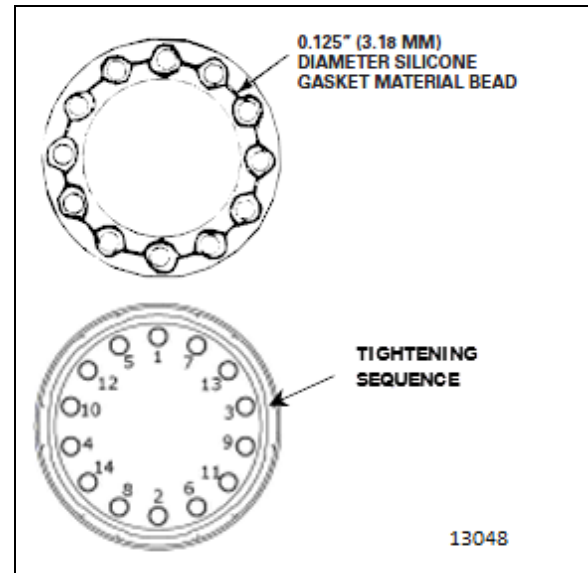

FIGURE 80: AXLE FLANGE TIGHTENING SEQUENCE

NOTE

During regular inspection, do not forget to check lubricant level in differential. Clean thoroughly or replace vent as required.

13. ZF DRIVE AXLE WHEEL HUBS

The ZF A132 hypoid single reduction drive axle hub (FIGURE 81) is fitted with unitized bearing known as compact bearing in ZF's literature.

13.1 COMPACT BEARING (HUB UNIT) AXIAL PLAY CHECK

Check the compact bearing (hub unit) axial play at the intervals specified by the Lubrication And Servicing Schedule in Section 24: LUBRICATION & SERVICING. Furthermore, the bearing must be checked in case of brake disk change, ABS fault message and rising noise level at increasing speed.

Perform compact bearing (hub unit) axial play check as described in paragraph 6.2 HOW TO CHECK THE AXIAL PLAY of the following manual: OPERATING INSTRUCTIONS ZF AXLE A132 (version with US hub) #5871 207 982 EN.



MAINTENANCE

Compact bearing (hub unit) axial play

Check the bearing axial play at the intervals specified by the Lubrication And Servicing Schedule in Section 24: LUBRICATION & SERVICING.

13.2 COMPACT BEARING (HUB UNIT) GREASE CHANGE

When grease is changed within the scope of the maintenance, it is necessary to completely remove the compact bearing.

Perform compact bearing (hub unit) grease change as described in paragraph 7.3 GREASE CHANGE IN THE HUB of the following manual: OPERATING INSTRUCTIONS ZF AXLE A132 (version with US hub) #5871 207 982 EN.



MAINTENANCE

Compact bearing (hub unit) grease change – ZF Lubricant class 12H

The compact bearing grease must be change at the intervals specified by the Lubrication And Servicing Schedule in Section 24: LUBRICATION & SERVICING.

The list of approved Lubricant Class 12H grease types is found in ZF's list of lubricants TE-ML 12.

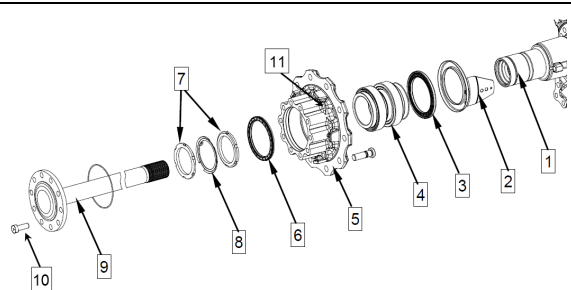

FIGURE 81: ZF A-132 DRIVE AXLE HUB ASSEMBLY

- 1 hub carrier
- 2 screen sheet
- 3 shaft seal (with impulse disc)
- 4 compact bearing (hub unit)
- 5 hub
- 6 shaft seal
- 7 slotted nut
- 8 locking plate
- 9 flange shaft
- 10 cap screw M18x1.5x50mm G10.9
TORQUE= 325 lb-ft (441 Nm)
(use 14mm hex socket driver "Allen")



14mm hex socket driver "Allen"

- 11 cap screw Torx M16x1.5x60,
TORQUE= 221 lb-ft (300 Nm)
(use E20 Torx socket)



E20 Torx socket

14. SPARE WHEEL

Tire failure is a rare event if tires are properly cared for. In case of a flat tire, move vehicle a safe distance away from traffic and apply parking brake. Remember to use the hazard flashers and according to the Highway Code regulations, set up the triangular reflectors (see "Emergency Warning Reflectors" in the Operator's Manual) at an adequate distance, to warn incoming motorists. This kit is located at the ceiling of the forward baggage compartment, on the R.H. side for H3 series vehicles and in the front service compartment on X3 Series.

The spare wheel is stored in a dedicated compartment behind the front bumper. To access, pull the release handle located in the front service compartment. Although the bumper is heavy, sprung hinges permit one person operation.

When closing bumper compartment, make sure bumper is securely installed.

NOTE

Converted vehicles are not equipped with a spare wheel. Access to compartment is also obtained by pulling the release handle located in the front service compartment.



WARNING

This compartment has not been designed for storage. Never leave loose objects in this area since they may interfere with steering linkage mechanism. Make sure bumper is safely locked in place after closing the compartment.

14.1 SUPER SINGLE TIRE REPLACEMENT

Increase tire pressure to 125 PSI If you are using the supplied 365/70 R 22.5 spare tire to replace a super single tire on the drive axle.

14.2 PULLING OUT SPARE WHEEL

To remove the spare on X3 series vehicles, untighten the pressure screw holding the tire in place, then press down on the spring loaded locking pin located at the top of the retaining bracket and remove the bracket.

On H3 series vehicles, Untighten the pressure screw holding the tire in place. Lift the pressure screw arm and move to the side.

Using the strap, pull the spare out of the compartment (refer to the following illustrations). Rollers ease manipulation. Remove the protective cover. Install the flat in place of the spare by reversing the procedure. Do not forget to have the flat repaired as soon as possible.

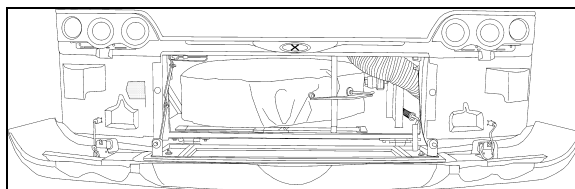

FIGURE 82: X3 SERIES SPARE WHEEL COMPARTMENT
18614

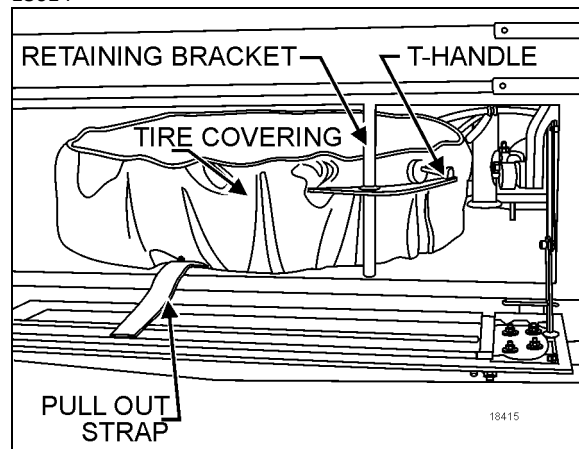

FIGURE 83: X3 SERIES SPARE WHEEL AND TIRE 18415

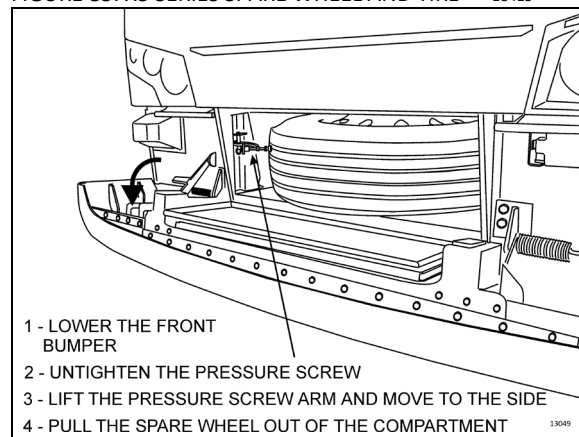

FIGURE 84: H3 SERIES SPARE WHEEL AND TIRE

NOTE

On H3 series vehicles, the pressure screw arm must return to its initial position otherwise, the bumper cannot be latched in upper position.

NOTE

The jack and wheelnut wrench are stored in the front service compartment for X3 series vehicles and at the ceiling of the forward baggage compartment, on the R.H. side for H3 series vehicles

The jack/tools kit contains a:

1. 30 ton hydraulic jack;
2. Wheel nut wrench and lever.

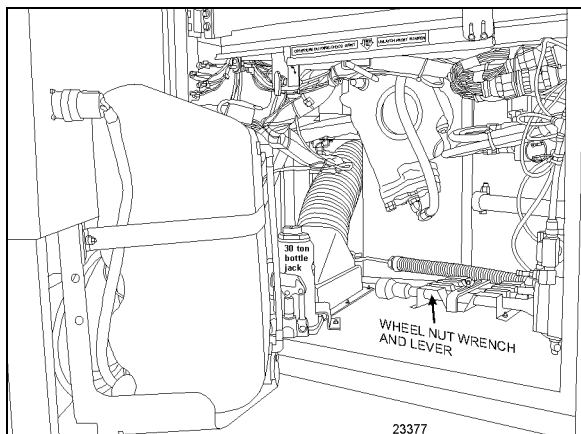

FIGURE 85: FRONT SERVICE COMPARTMENT OF A X3 SERIES VEHICLE

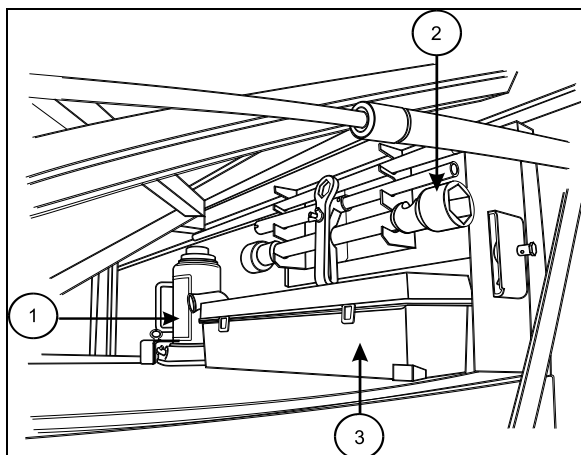

FIGURE 86: FORWARD COMPARTMENT OF H3 SERIES VEHICLE WITH JACK, WRENCH AND REFLECTOR KIT.

NOTE

Check the inflation pressure of the spare tire periodically to keep it ready for use. Inflate spare tire to the pressure of the tire, which has the highest pressure on the vehicle. When installing, deflate to correct pressure if necessary.

14.3 CHANGING A FLAT TIRE (COACHES ONLY)

In case of flat tire, refer to appropriate procedure under "Wheel Maintenance" heading in this section.

NOTE

For hydraulic jack placement, refer to Section 18 "Body", under heading "Vehicle Jacking Points".

DANGER

Place jack on stable and level ground; if necessary, place a board under the jack. Do not raise the vehicle until you are sure the jack is securely engaged.

WARNING

To prevent personal injury and/or equipment damage, use only the recommended jacking points. Passengers must not remain inside vehicle while wheel is being replaced.

CAUTION

Adjust tire pressure according to the appropriate cold tire inflation-pressure.

NOTE

Store damaged wheel in spare tire compartment. Repair and balance the flat tire as soon as possible.

14.4 CHANGING A FLAT TIRE (VIP & CONVERTED BUS SHELLS)

In case of a flat tire, turn ON the hazard flashers and bring the vehicle to a stop on the side of the road. Apply the parking brake. Make sure the vehicle is parked safely away from traffic. Set up the triangular reflectors in accordance with applicable highway regulations.

It is strongly suggested that you **do not** attempt to change a wheel, the wheel and tire are very heavy and there is usually no space available to put the removed flat. Also, the wheel nuts, especially those on inner dual, can become very tight after being on for only a short time. Often a heavy air wrench will be required to get the nuts

loose. Get help via cellular phone, there are truck tire service enterprises all over the country that can bring a wheel and make the change safely.

NOTE
Bus shell vehicles contain no spare wheel. Access to compartment is obtained by pulling the release handle located in the front service compartment.

 **WARNING**
The reclining bumper compartment has not been designed for storage. Never leave loose objects in this area since they may interfere with steering linkage mechanism. Make sure bumper is safely locked in place after closing the compartment.

14.5 SPARE WHEEL MAINTENANCE

Maintenance of the spare wheel and tire consists in ensuring that tire inflation pressure is the same as the tire on the coach that has the highest inflation pressure (refer to “Specifications” in this section for the recommended tire inflation pressure). Inspect rim to ensure that there is no important corrosion. In addition, check if spare wheel covering is in good condition and check that spare tire is securely fastened in compartment.



15. VALVE INSTALLATION



CAUTION

When replacing valve stems, lubricate the threads and O-ring with Permatex Dielectric Tune-Up grease (Prevost #685324) to avoid galvanic corrosion.

Tip: When installing the valves, use as needed a 15mm wrench to hold the valve and block the rotation.

Steel Wheels	<p>All wheels</p> <p>8.25 inches wheel, valve 650017</p> <p>9 inches wheel, valve 650018 (shown)</p> <p>Install the valve in place.</p> <p>Torque 31-39 lb-ft (42-53 Nm)</p>	 <p>#Prevost 650018</p>	
	Aluminum Wheels	<p>365 tire</p> <p>Valve 650014</p> <p>Install the valve in place.</p> <p>Torque 106-133 lb-in (12-15 Nm)</p>	 <p>#Prevost 650014</p>
Aluminum Wheels	<p>315 tire</p> <p>Valve 650015</p> <p>Install the valve in place.</p> <p>Torque 106-133 lb-in (12-15 Nm)</p> <p>Add an 1 3/8" extension, 650201 for wheels on:</p> <ul style="list-style-type: none"> -Front axle tire -Tag axle tire -Spare tire 	 <p>#Prevost 650015</p>  <p>#Prevost 650201</p>	

	<p><u>Super Single tire</u> Valve 650013</p> <p>Install the valve in place.</p> <p>Torque 106-133 lb-in (12-15 Nm)</p>	 <p>#Prevost 650013</p>	
--	---	--	---

15.1 TPMS SENSORS INSTALLATION

<p>Check proper valve positioning before installing sensor onto valve (risk of damaging the sensor or air leaks).</p>	
<p>Pressure sensor #560032.</p> <p>Remove bar code with supplied removable tie-rip.</p> <p>Make sure never to mix the bar code between the wheels. (bar code is linked to sensor)</p>	
<p>Positioning the sensor on the wheel. Ensure that the sensor is well pressed onto the surface.</p>	
<p>Torx screw T-20</p> <p>TORQUE: 35 lb-in (4 Nm)</p> <p>IMPORTANT</p> <ul style="list-style-type: none"> -Put blue Loctite 243 to the threads. -Use the screw only once. -Replacement screw #651084. 	

SECTION 13: WHEELS, HUBS AND TIRES

Install bar code and tie it up using wheel holes. Use supplied removable tie-rap.



Apply decal facing the valve.



#651091 ENGLISH #651090 BILINGUAL



16. TIRE MAINTENANCE

The most critical factor in tire maintenance is proper inflation (Figure 87). No tire is impervious to loss of air pressure. To avoid the hazards of under inflation, always maintain tires at their recommended inflation pressure. Improper inflation decreases tire life.

NOTE

VIP & Converted Bus Shells vehicles are not at their maximum weight before their conversion and tire pressures are adjusted at lower level than the maximum allowed appearing on the DOT plate. Tires pressure must be re-adjusted once converted.

An under inflated tire builds up heat that can cause sudden tire destruction, resulting in improper vehicle handling and possible loss of vehicle control. At least once a week, before driving (when tires are cold), check inflation pressure on all the tires, including the spare tire. This is especially important in cases when different drivers operate the vehicle.



WARNING

Failure to maintain correct tire inflation pressure may result in sudden tire destruction, improper vehicle handling, and will cause rapid and irregular tire wear. Inflation pressure should be checked weekly and always before long distance trips.

16.1 INFLATION PRESSURE

- Vehicles equipped with BERU TPMS

On vehicles equipped with the Beru Tire Pressure Monitoring System (TPMS), it is better to use the TPMS display as the primary reference to judge when tire pressure need adjustment.

The TPMS presents pressure readings of each tire as a +/- deviation from the wanted target.

If a tire reads within +/- 3 PSI no adjustment is needed.

If a tire reads -4 PSI and below, re-inflate by the marked amount.

If a tire reads +4 PSI and above, deflate by the marked amount.

NOTE

Relying on the TPMS system is better than relying on a hand gage since the TPMS is temperature compensated and remain accurate no matter if the tires are cold or hot.

Tires take up to 3 hours to get down to ambient temperature after a ride. A common mistake consist of checking pressure while the tires have not fully cooled down which leads into under-inflated tires. Relying on the TPMS eliminates this mistake.

Running tires at optimal pressure reduces tire wear, improving safety and fuel economy.

The TPMS target pressures are factory set to equal the prevailing tire pressure at delivery time.

When tire pressures are increased to account for higher vehicle weight, the TPMS set point need to be increased accordingly.

- Vehicles not equipped with BERU TPMS

The condition and pressure of the tires can greatly affect both useful tire life and road safety.

At regular intervals, verify the tire pressures. Use an accurate tire pressure gauge when checking inflation pressures. Never exceed the maximum inflation pressure specified on each tire.

NOTE

Inflation pressure should be checked when tires are cold. Cold tire inflation pressure can be measured when a vehicle has not been driven for at least 3 hours or less than 1 mile (1.6 km). Driving, even for a short distance, causes tires to heat up and air pressure to increase. Check inflation pressure on all tires (including the spare tire) using an accurate tire gauge.

NOTE

The recommended tire inflation pressures are given in the applicable documents supplied with the vehicle. In addition, cold tire inflation pressures are listed on the Department of Transport's certification plate, affixed on the panel behind the driver's seat for H3 series vehicles and on the left side control panel for X3 series vehicles. For special tire selection, a

"PREVOST COACH SPECIAL SPECIFICATION" chart is supplied with the vehicle and is affixed on the left wall near the driver's seat. Remember, tire inflation pressure must be adjusted according to vehicle loading - see table in "Coach Final Record"

CAUTION

These tire pressures are established in accordance with the maximum allowable load on each axle. A lower pressure is recommended if the axle load is less than the above specifications. Weigh vehicle fully loaded and pressurize according to tire manufacturer's recommendations. For other tire and wheel specifications, see Prevost tire pressure tabulation in "Coach Final Record".

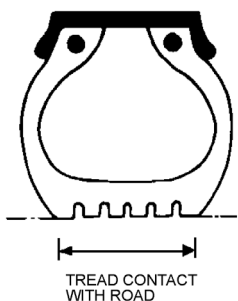

PROPER INFLATION
The correct profile for full contact with the road for traction, braking capability and safety.

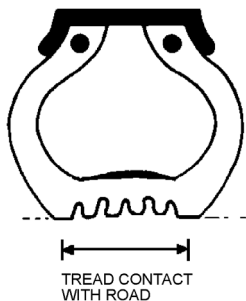

UNDER INFLATION
Causes abnormal tire deflection which builds up heat and causes irregular wear.

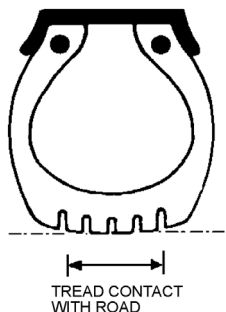

OVER INFLATION
Causes tires to run hard and to be more vulnerable to impacts. It also causes irregular wear.

13009

FIGURE 87: TIRE INFLATION

CAUTION

Never bleed air from hot tires as tires will then be under inflated. Use an accurate tire gauge to check pressures (Do not kick tires as an inflation check. This is an unreliable method).

WARNING

Incorrect tire pressures cause increased tire wear and adversely affect road holding of the vehicle, which may lead to loss of vehicle control.

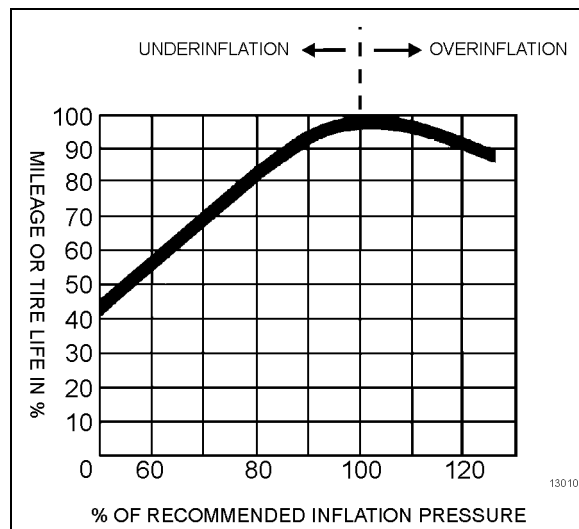

FIGURE 88: TIRE LIFE / INFLATION PRESSURE

WARNING

Recommended tire inflation pressures and maximum allowable loads apply to speeds up to 65 mph (105 km/h). Do not drive vehicle at a higher speed than 65 mph (105 km/h) or above the posted speed limit.

WARNING

All tires on the same axle should always be inflated to the same pressure. There should not be a difference in pressure between right and left tires on the same axle.

A 5 psi (35 kPa) under-inflation in one front tire can not only reduce vehicle maneuverability, but will create steering hazards which can lead

to an accident.

There is no restriction on criss-cross rotation.

16.2 TIRE MATCHING

Unmatched tires on drive axle will cause tire wear and scuffing, as well as possible damage to the drive unit. Consequently, It is recommended that tires be matched within 1/8" (3 mm) of the same rolling radius.

NOTE

It is recommended that all tires on coach be of the same type.

16.3 WHEEL BALANCING

Before balancing, wheels must be clean and free from all foreign matter. The tires should be in good condition and properly mounted. An unbalanced wheel can be due to a bent wheel or improper mounting. Before removing the wheel from the vehicle, check for swaying movement and if necessary, check the wheel lateral run-out as outlined under heading "*Wheel Straightness Check*".



WARNING

When balancing wheel and tire assemblies, it is strongly recommended to closely follow instructions covering the operation of wheel balancer.



CAUTION

A maximum of 16-oz (450 g) of balancing weight is recommended. If more weight is necessary, check and correct the cause.

16.4 TIRE ROTATION

Radial tires should be rotated only when necessary. If the tires are wearing evenly, there is no need to rotate. If irregular wear becomes apparent or if the wear rate on the tires is perceptively different (from axle to axle), then tires should be rotated in such a manner as to alleviate the condition.

NOTE

17. SPECIFICATIONS

STEEL WHEELS

Wheel size..... 9.0" X 22.5"
 Tire size..... 315/80 R 22.5

ALUMINUM WHEELS

Wheel size..... 9" X 22.5"
 Tire size..... 315/80 R 22.5

OPTIONAL FRONT & TAG AXLE ALUMINUM WHEELS (Standard on VIP vehicles)

Wheel size..... 10.5" X 22.5"
 Tire size..... 365/70 R 22.5

OPTIONAL WIDE BASE TIRE ALUMINUM WHEELS

Wheel size..... 14" X 22.5"
 Tire size..... 455/55 R 22.5

RECOMMENDED TIRE INFLATION PRESSURE AT MAXIMUM LOAD (cold)

NOTE

Vehicle is delivered with the specific inflation pressure certification plate according to the tire selection. For more information consult section 11 "Technical information" of the Owner's/Operator's manual under "DOT Certification Plate".

 **WARNING**

Special tire selection may lower maximum allowable speed limit, even below posted speed limit. For maximum safety, check with tire manufacturer.

 **CAUTION**

Bus shell vehicles should be weighed fully loaded and tires pressurized according to tire manufacturer's recommendations.

 **WARNING**

Recommended tire inflation pressures and maximum allowable loads apply to speeds up to 65 mph (105 km/hr). Do not drive vehicle at a higher speed than 65 mph (105 km/h) or above the posted speed limit.