

CONTENTS

SECTION CHANGE LOG	5
1. TORQUE TABLES	6
2. VEHICLE EXTERIOR	9
3. VEHICLE JACKING POINTS	11
3.1 HYDRAULIC JACK	11
4. TOWING THE VEHICLE	11
5. STRUCTURE	11
5.1 WELDING	11
6. EXTERIOR MAINTENANCE	12
6.1 CORROSION PREVENTION	12
6.2 PREVENTIVE MAINTENANCE SCHEDULE	13
6.3 RUST INHIBITOR APPLICATION	14
7. FIBERGLASS REPAIR	18
7.1 REPAIR USING FIBERGLASS CLOTH	19
7.2 REPAIR USING FIBERGLASS PASTE	19
7.3 TYPICAL FIBERGLASS REPAIR PROCEDURE	20
8. PAINTING	21
8.1 NEW PAINT CARE	21
8.2 PAINT TOUCHUP	21
8.3 PAINTING	21
8.3.1 <i>Safety</i>	22
8.3.2 <i>Surface Preparation and Paint Application</i>	22
8.4 FRONT AND REAR BUMPERS	23
8.4.1 <i>Paint touchup and surface preparation for vehicles equipped with urethane bumpers</i>	23
9. FRONT AND REAR BUMPERS	23
9.1 FRONT BUMPER REMOVAL AND INSTALLATION	23
9.1.1 <i>Front Bumper Removal</i>	23
9.1.2 <i>Front Bumper Skin Removal</i>	23
9.1.3 <i>Front Bumper Assembly Removal including spare wheel compartment door</i>	24
9.2 FRONT BUMPER LICENSE PLATE SUPPORT INSTALLATION	24
9.3 REAR BUMPER REMOVAL AND INSTALLATION	24
10. COACH ENTRANCE DOOR	25
10.1 OPERATION	25
10.2 EMERGENCY EXIT VALVES	25
10.2.1 <i>Without Air and/or Without Electricity</i>	26
10.2.2 <i>With Air but Without Electricity</i>	26
10.3 DOOR CYCLE SPEED ADJUSTMENT	26
10.4 HORIZONTAL AND VERTICAL ADJUSTMENT	27
10.5 DEPTH ADJUSTMENT	28
10.6 ROD END ADJUSTMENT	28

10.7	LUBRICATION	29
10.8	TROUBLESHOOTING	30
11.	ENTRANCE DOOR (V.I.P.).....	31
11.1	KEYLESS ENTRY SYSTEM.....	31
11.2	DOOR ADJUSTMENT	31
11.2.1	<i>Horizontal and Vertical Adjustments</i>	<i>31</i>
11.3	DEPTH ADJUSTMENT	31
11.4	DOOR LOWER SECTION	32
11.5	REFLECTOR STRIPE INSTALLATION.....	32
11.6	DOOR SEAL REPLACEMENT.....	33
11.7	DOOR LUBRICATION	33
11.8	DOOR LATCH MECHANISM	33
12.	DRIVER'S POWER WINDOW	33
12.1	POWER WINDOW REMOVAL.....	33
12.2	POWER WINDOW INSTALLATION.....	34
13.	DASHBOARD – R.H. SIDE PANEL REMOVAL.....	34
14.	ROOF ESCAPE HATCH	35
14.1	REPAIR	35
14.2	SEALING	35
14.3	ESCAPE HATCH PANEL ASSEMBLY	36
14.4	ESCAPE HATCH FRAME	36
15.	REPAIR OR REPLACEMENT OF “TARABUS” FLOOR COVERING	37
15.1	FRONT STEPS REPLACEMENT PROCEDURE.....	39
15.2	WELDING OF JOINT BETWEEN WHITE SAFETY STRIP AND “TARABUS” FLOOR COVERING	42
15.3	REPAIR OF A WELDED JOINT.....	43
16.	PASSENGER SEATS	44
16.1	ROTATING SEATS	44
16.2	REMOVING FIXED SEATS.....	45
16.3	UPHOLSTERY MAINTENANCE	45
16.3.1	<i>Routine Cleaning.....</i>	<i>45</i>
16.3.2	<i>Dry Cleaning.....</i>	<i>46</i>
16.3.3	<i>Cleaning With Covers in Place.....</i>	<i>46</i>
17.	COACH SIDE WINDOWS	46
17.1	HYDROPHOBIC TREATMENT ON SIDE WINDOWS	46
17.2	EMERGENCY EXIT WINDOWS	47
17.3	EMERGENCY EXIT RELEASE BAR.....	47
17.3.1	<i>Emergency Exit Window Adjustment.....</i>	<i>47</i>
17.4	FIXED WINDOW REPLACEMENT	47
17.5	EMERGENCY EXIT WINDOW REPLACEMENT	48
17.6	TRAPEZOIDAL WINDOW REPLACEMENT	48
17.7	SMALL REAR WINDOWS REPLACEMENT	48
17.8	ADHESIVE-MOUNTED WINDOWS.....	49
17.8.1	<i>Glass Window Replacement</i>	<i>49</i>
18.	ELECTRIC AWNING WINDOW	50
18.1	OPERATION.....	50

18.2	WINDOW REMOVAL	51
18.3	ACTUATOR REPLACEMENT	52
18.4	MOTOR REPLACEMENT	52
19.	ELECTRIC SLIDING WINDOW.....	54
20.	WINDSHIELD.....	57
20.1	REMOVAL.....	57
20.2	WINDSHIELD INSTALLATION	58
20.2.1	<i>Preparation</i>	58
20.2.2	<i>Installation of rubber extrusion</i>	59
20.2.3	<i>Windshield insertion</i>	61
20.2.4	<i>Locking strip insertion</i>	61
21.	BODY PANELS AND DOORS	63
22.	WHEELCHAIR LIFT ACCESS DOOR.....	64
22.1	INSTALLATION.....	64
22.2	ADJUSTMENT	64
23.	BAGGAGE COMPARTMENT DOORS	68
23.1	PANTOGRAPH ADJUSTMENT	68
24.	DOOR HANDLES	69
25.	ENGINE COMPARTMENT DOOR.....	69
25.1	ENGINE DOOR ADJUSTMENT.....	69
25.2	MINOR TOP EDGE DEPTH ADJUSTMENT	70
25.3	MINOR LOWER EDGE DEPTH ADJUSTMENT:	70
26.	ENGINE AIR INTAKE GRILL	70
27.	RADIATOR DOOR ADJUSTMENT	70
27.1	DOOR HEIGHT ADJUSTMENT	70
27.2	DOOR LATERAL ADJUSTMENT	71
27.3	DOOR DEPTH ADJUSTMENT	71
28.	CONDENSER DOOR ADJUSTMENT	72
29.	FUEL FILLER DOOR	73
30.	FRONT SERVICE COMPARTMENT.....	73
30.1	LATCH MECHANISM ADJUSTMENT.....	74
31.	ENGINE COMPARTMENT R.H. SIDE DOOR.....	74
31.1	LATCH MECHANISM ADJUSTMENT.....	75
32.	EVAPORATOR DOOR ADJUSTMENT	75
32.1	LATCH MECHANISM ADJUSTMENT.....	75
33.	MAIN POWER COMPARTMENT	76
33.1	LATCH MECHANISM ADJUSTMENT.....	76
34.	FENDERS.....	76

34.1	REAR FENDER REMOVAL.....	77
34.2	FRONT FENDER REMOVAL.....	77
35.	REAR CAP	77
36.	FRONT CAP	77
37.	SIDE PANEL INSTALLATION PROCEDURE FOR COACHES AND VIP.....	78
38.	REAR-VIEW MIRROR	84
38.1	ARM AND BRACKET POSITION	84
38.2	REAR-VIEW MIRROR REMOVAL.....	84
38.3	REPLACEMENT OF FLAT GLASS MIRROR.....	85
38.4	REPLACEMENT OF CONVEX GLASS MIRROR.....	86
	SPECIFICATIONS	87

SECTION CHANGE LOG

DESCRIPTION		DATE
1	Update – new exterior rear-view mirror	Oct. 2023
2	Update - additional information on flat glass mirror removing tool	Jan. 2025
3	Update – new opening mechanism for emergency exit windows (rollover)	Jan. 2025
4		
5		
6		

1. TORQUE TABLES

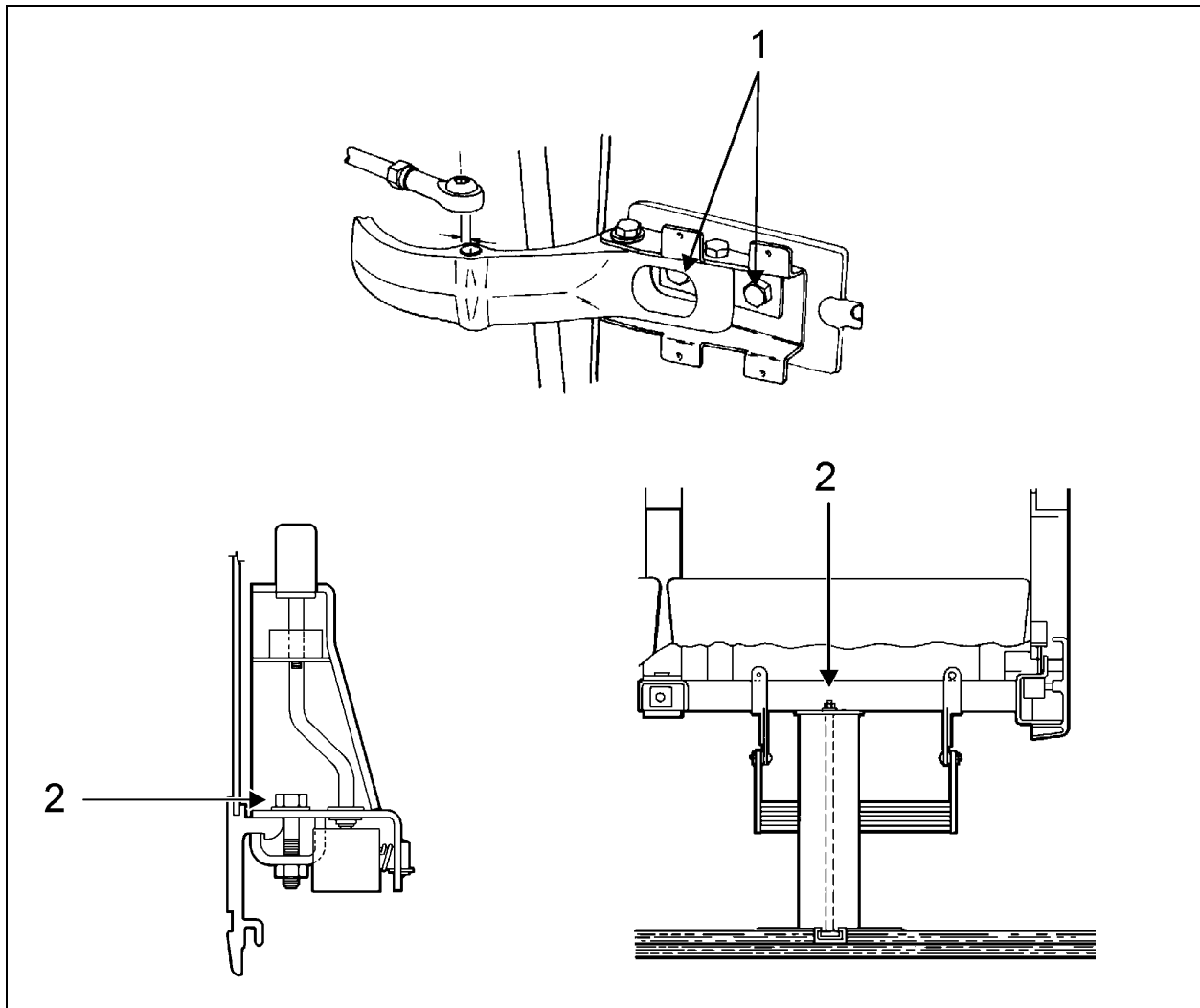
**BODY**

No	DESCRIPTION	TORQUE
1	Entrance door horizontal adjusting bolts	55-65 lb-ft (75-88 Nm)
2	Passenger seat mounting nuts (to sidewall and pedestal)	27 lb-ft (37 Nm)

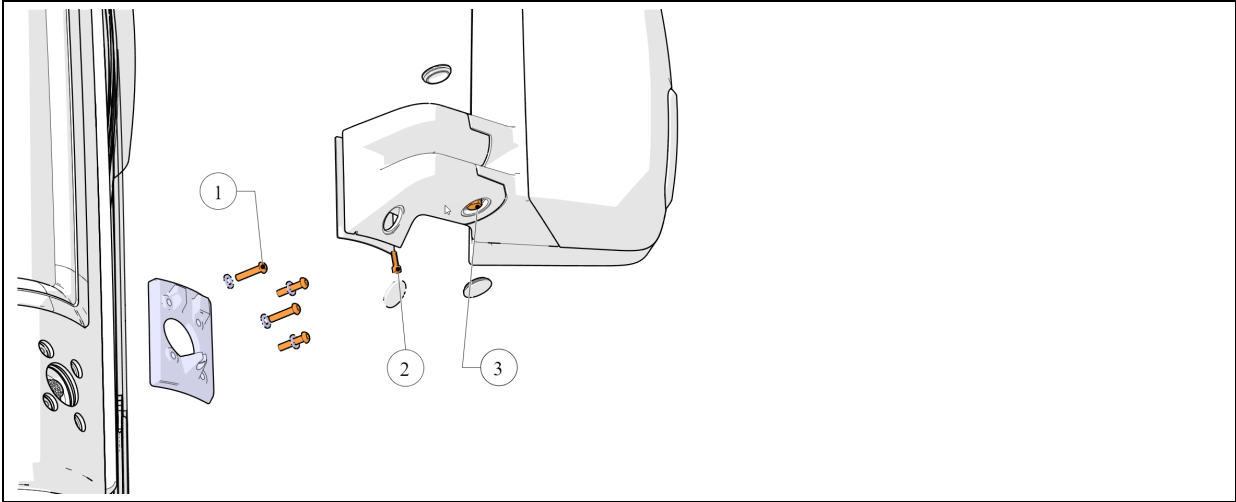

REAR VIEW MIRROR

No	DESCRIPTION	TORQUE
1	Mounting plate screw (4x) 14 lb-pi	14 lb-ft (19 Nm)
2	Clamping screw	84 lb-in (9 Nm)
3	Bolt, arm (2x)	25 lb-ft (34 Nm)

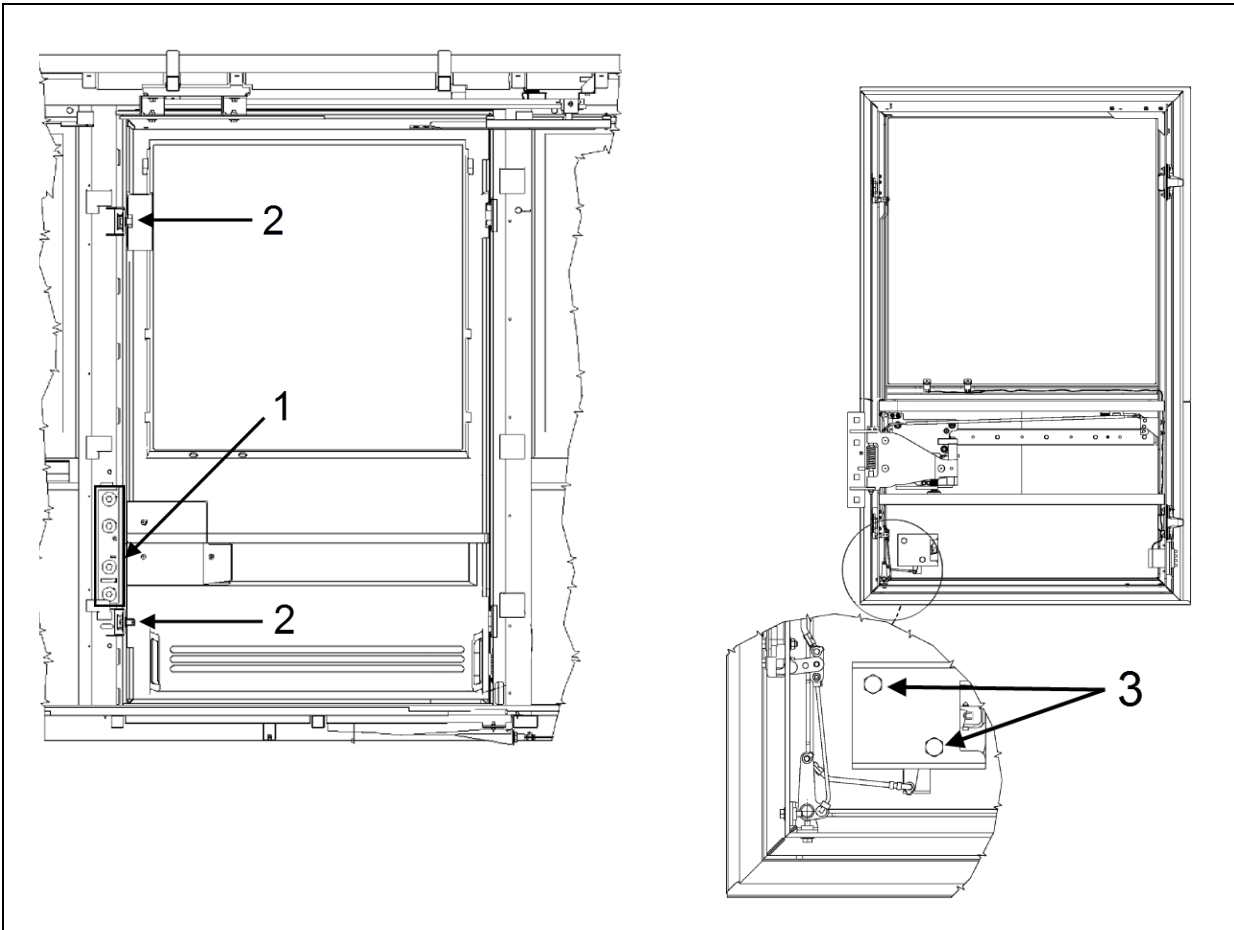

WHEELCHAIR LIFT DOOR

No	DESCRIPTION	TORQUE
1	Wheelchair lift door – Center hinge bolts	31-38 lb-ft (42-52 Nm)
2	Wheelchair lift door - striker pin adjustment bolts	54-66 lb-ft (73-89 Nm)
3	Wheelchair lift door - opening mechanism nuts	2.5-3.5 lb-ft (3.39-4.75 Nm)

2. VEHICLE EXTERIOR

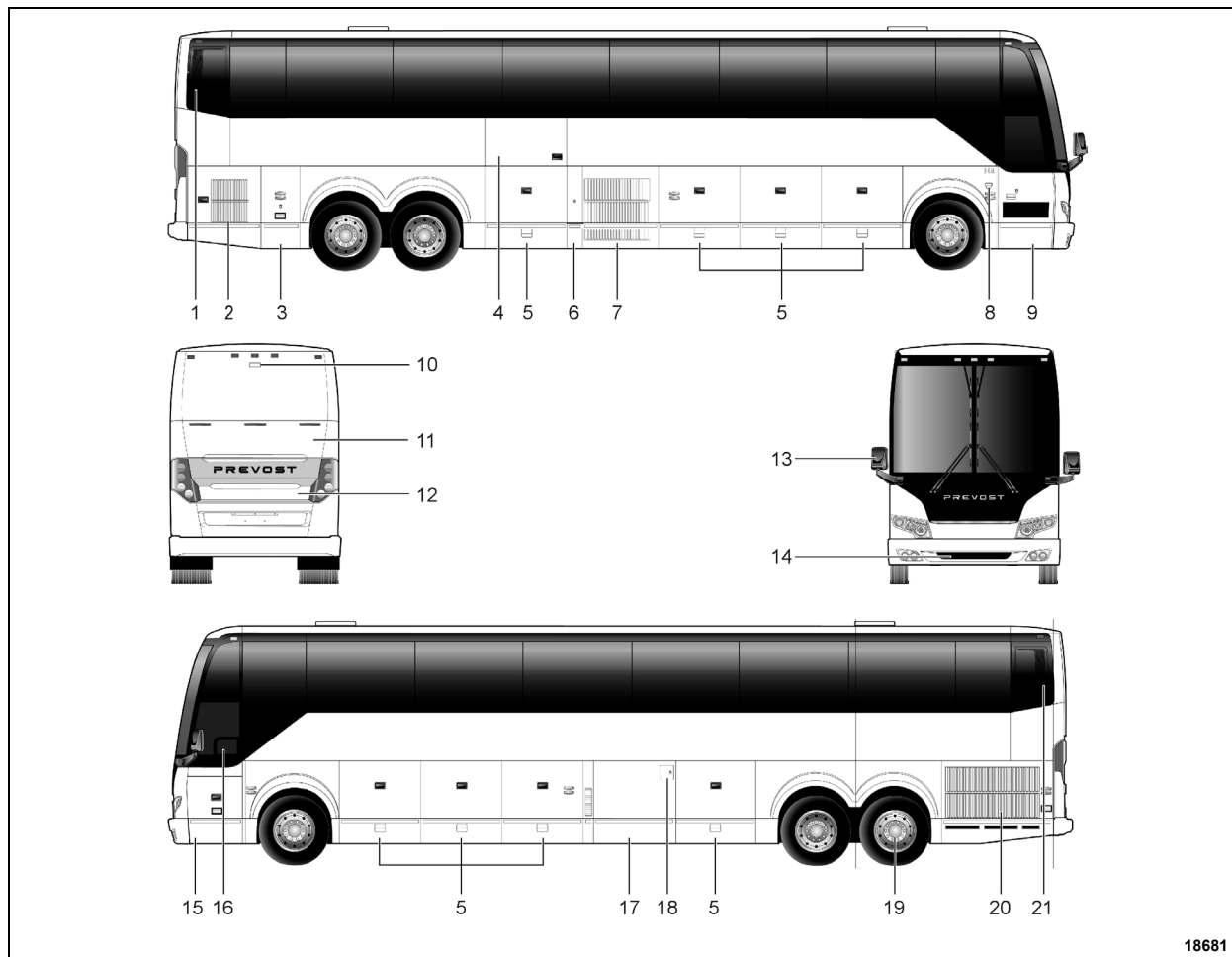

18681

FIGURE 1: H3-45 (TYPICAL)

- | | |
|--|---|
| 1. Engine air intake | 11. Diesel Particulate Filter (DPF) access door |
| 2. Engine compartment curb-side door | 12. Engine compartment rear door |
| 3. Main power compartment (battery compartment) | 13. Rear-view mirror |
| 4. Wheelchair access door (optional Ricon lift) | 14. Spare wheel compartment |
| 5. Baggage compartment | 15. Front electrical and service compartment |
| 6. Fuel filler neck and diesel exhaust fluid (DEF) filler neck access door | 16. Driver's power window |
| 7. Condenser compartment | 17. Evaporator compartment |
| 8. Entrance door control switch | 18. Fuel filler neck access door |
| 9. Entrance door | 19. Tag axle |
| 10. Back up camera (optional) | 20. Radiator door |
| | 21. SCR catalytic converter access door |

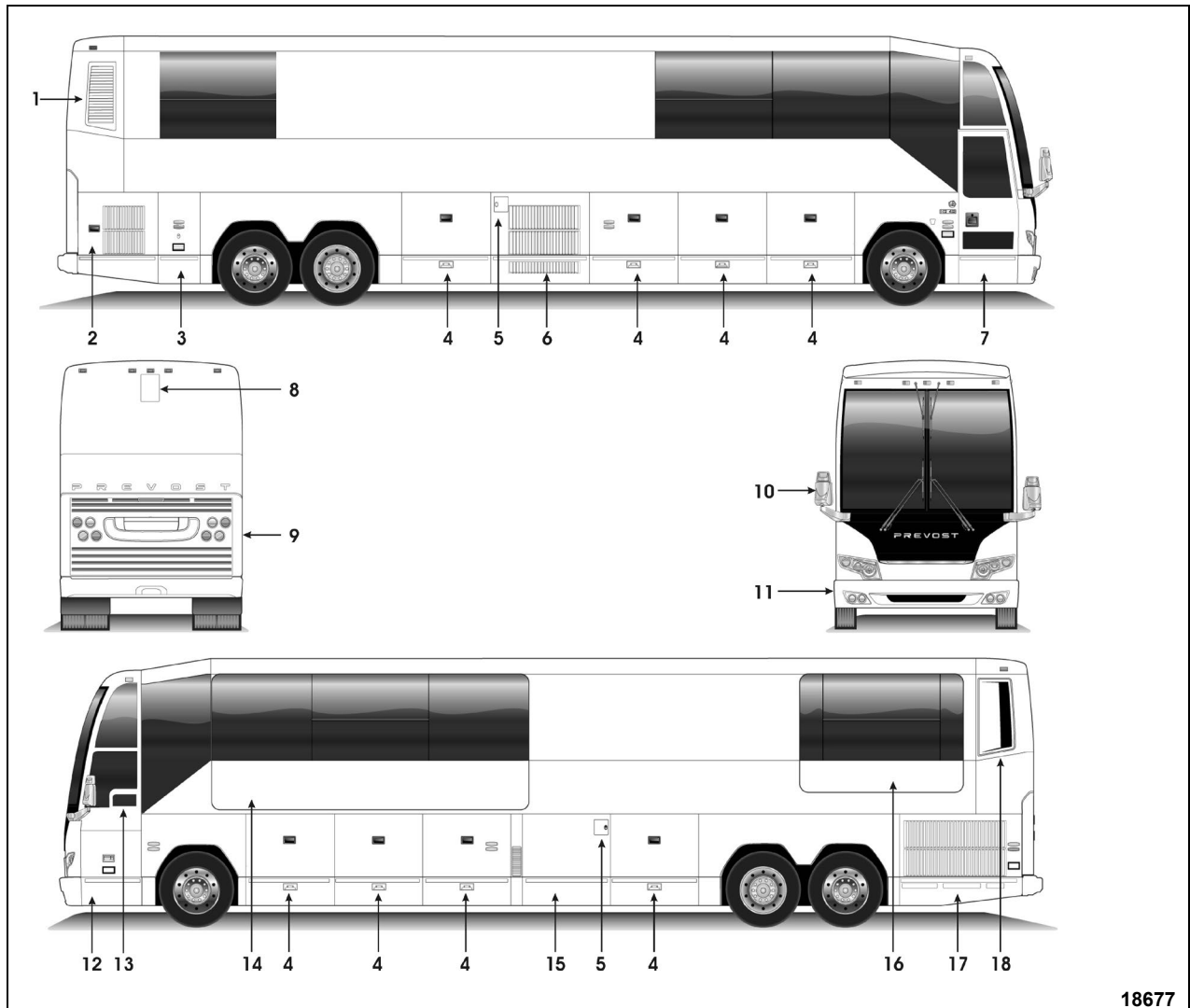

FIGURE 2: H3-45 VIP EXTERIOR VIEW

18677

1. Engine air intake
2. Engine R.H. side access door
3. Main power compartment
4. Baggage compartment
5. Fuel filler door
6. A/C condenser compartment or baggage compartment
7. Entrance door
8. Retractable back up camera (optional)
9. Engine compartment rear door
10. Rear-view mirrors
11. Reclining bumper compartment
12. Front electrical and service compartment
13. Driver's power window
14. Front Slide-out
15. Heating, ventilating and air conditioning compartment (HVAC) or baggage compartment
16. Rear Slide-out
17. Engine radiator door
18. Diesel Particulate Filter (DPF) compartment access door

3. VEHICLE JACKING POINTS

For detailed instructions, refer to Maintenance information [MI18-18](#), available on the technical publications USB flash drive and website.

3.1 HYDRAULIC JACK

To raise: turn release valve clockwise. Insert handle in socket and raise vehicle by pumping.

To lower: remove handle and turn the release valve slowly counterclockwise.

Always keep ram and extension screw retracted when jack is not in use.

Service: Check oil level when jack fails to raise to full height. Lower ram completely with release valve open and jack in upright position, remove filler plug and refill to level of filler hole with hydraulic jack oil. Never use brake fluid.



DANGER

Jack is intended for lifting only. Do not get under the vehicle or load for any reason unless it is properly supported with safety stands and securely blocked.



DANGER

Do not overload jack above rated capacity. Prevent "side loading", make sure load is centered on ram. Do not push or tilt load off jack.

4. TOWING THE VEHICLE

For detailed instructions, refer to Maintenance information [MI18-18](#), available on the technical publications USB flash drive and website.

5. STRUCTURE

The body of the H3-41, H3-45 and VIP vehicles is an integral structure made of 14, 16 and 18 gauge welded and braced high tensile steel and stainless steel members. The roof arches are made with cold rolled, electrically welded (CREW) steel tubes, 1 ½" x 2" x 14 gauge. The inside is filled with urethane foam and the exterior is primed. The front subframe is made of open sections of high-strength steel alloy. These open sections permit a better application of primer and undercoating, and does not trap moisture. The rear subframe is made of closed sections of high tensile steel sealed at both ends.

5.1 WELDING

Since welding is a procedure that may be carried out either as specific instructions from Prevost or by an independent decision of the owner, the following information pertaining to welding should be read before beginning any welding procedure. The prohibitions and requirements outlined below must be followed during welding procedure:

1. Welding must be done only by a qualified and experienced person.
2. Adequate ground contacts and shields must be positioned as required to protect

components from damage due to heat, contact by weld splatter, arcing, or other potentially damaging events associated with welding.

3. Refer to “*PRECAUTIONS TO BE OBSERVED BEFORE WELDING*” in Section 00 General Information of this manual.
4. Always wear the appropriate safety equipment.

Weld in clean and well-ventilated area, and always have an appropriate fire extinguisher within your reach

6. EXTERIOR MAINTENANCE

Regular washing to remove dust and dirt is recommended. See “*Operator’s Manual*” or “*Owner’s Manual*” for more details on washing and cleaning your vehicle.

6.1 CORROSION PREVENTION

Preventive maintenance is a key factor in avoiding corrosion and must be considered as part of the regular service intervals. The entire underbody of the vehicle is sprayed with a heavy application of asphalt base undercoating.

The operating environment the vehicle is subjected to will largely influence the amount of dirt and corrosion that will accumulate over a given period. Corrosion is one of the most costly factors of part failure and shortened part life. It is, however, an item that can be controlled when it is conscientiously looked after and the proper steps are taken in a timely manner.

Certain areas of the coach are more vulnerable to corrosion than others, and it is these areas that should be addressed. For example, the rear baggage compartment bulkhead in the rear wheelhousing area contains many key components and should be examined regularly for corrosion. Other areas include the front wheelhousing area and the engine compartment.

Road splash will affect understructure, condenser coil and engine compartment. These areas must be thoroughly cleaned to remove dirt accumulations from flanges, channels and ledges. These places accumulate dirt and salt and hold it in direct contact with steel and aluminum surfaces. Use an understructure high pressure spray as part of a regular wash. Damaged undercoating or paint should be promptly repaired before corrosion can start.

Frequency of wash periods depends on operating conditions. During periods of exposure to salt, daily washing as described above is recommended. If underbody parts show evidence of rust or corrosion, treat as follows:

1. Remove dirt, grease and oil by solvent washing.
2. Remove corrosion as well as all loose coating by cleaning with a wire brush or sandblasting.



CAUTION

Sandblasting can be used for cleaning bulkheads, brackets and other structural members. It should not be used for exterior side paneling. Extreme care should be taken not to sandblast excessively.

3. Apply correct primer, paint and undercoating after removing all corrosion to prevent further damage.

6.2 PREVENTIVE MAINTENANCE SCHEDULE

NOTE

TECTYL 185 GW rust inhibitor may have been applied on your vehicle underbody as an option, if this is the case, follow this procedure thoroughly. For future application of product, refer to paragraph 3.3 in this section.

DESCRIPTION	INTERVALS		MAINTENANCE	CORRECTIVE ACTION	REFERENCE
	MONTHS	KM MILES			
BODY, EXTERNAL WINDOW FRAME	6	40 000 25 000	VISUALLY INSPECT SEALING BEADS CONDITION	REPAIR OR REPLACE SEALING BEADS IF NECESSARY	
VEHICLE UNDERBODY	12	100 000 60 000	USE A LOW PRESSURE SPRAY TO CLEAN UNDERSTRUCTURE AND VISUALLY INSPECT FOR CALCIUM DEPOSIT, CORROSION OR ANY DIRT ACCUMULATED ONTO EXPOSED SURFACES. VISUALLY INSPECT SEALING BEADS CONDITION. VISUALLY INSPECT IF UNDERFLOOR IS PEELING. VISUALLY INSPECT WHEELHOUSING COATING. MAKE SURE DISCHARGE TUBES ARE FREE FROM OBSTRUCTIONS	APPLY UNDERCOATING LOCALLY AS NECESSARY. APPLY UNDERCOATING LOCALLY AS NECESSARY REMOVE ANY OBSTRUCTION OR REPLACE DEFECTIVE TUBE	
SUSPENSION AND UNDERSTRUCTURE	12	100 000 60 000	VERIFY THE CONDITION OF ALL SUSPENSION AND UNDERSTRUCTURE FASTENERS AND CLAMPS	TIGHTEN OR REPLACE DEFECTIVE OR MISSING FASTENERS	
FLOOR COVERING	3	20 000 12 500	VISUALLY INSPECT IF FLOOR COVERING IS SHOWING SIGNS OF DETERIORATION SUCH AS CUTS, BURNS, ETC. ALSO, VISUALLY INSPECT SEALANT ALONGSIDE TRACKS. INSPECT WALL PANELS FROM BOTTOM TO WINDOWS	REPAIR OR REPLACE DEFECTIVE COVERING. MAKE SURE PROPER SEALANT IS USED.	
FLOOR CLEANING			CLEAN FLOOR COVERING AS NECESSARY		



**WARNING**



Failure to follow this preventive maintenance schedule will result in warranty void.

6.3 RUST INHIBITOR APPLICATION

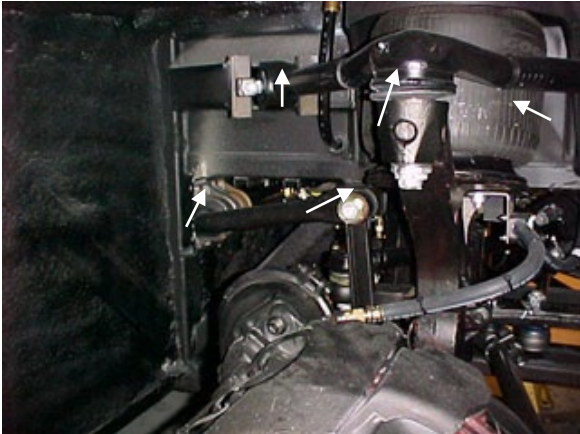
Material: Tectyl 185 GW
R1KG21

Safety Rules: Use safety glasses
Supplied air hood
Solvent-resistant rubber gloves

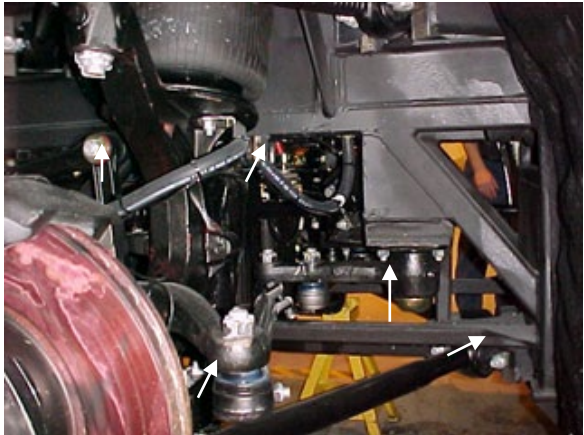
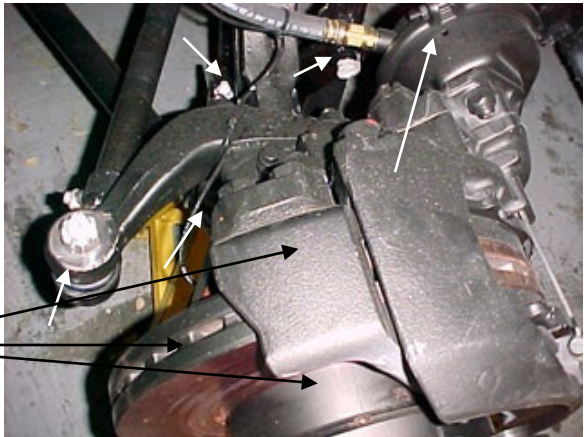
<p>1.0 Wash both wheelhousing mechanical parts before masking.</p>	<p>A water-hose nozzle is recommended. Water may be hot to reduce washing time especially during winter. If parts are soiled with oil, clean using R1KG21. Avoid rubber parts.</p>
<p>2.0 Dry all water sprayed parts. Surface temperature and dew point must be respected before applying rust inhibitor.</p>	<p>Air pressure system may be used, refer to annex 1 for surface temperature and dew point.</p>
<p>3.0 Front wheelhousing</p> <p>a) Mask all rubber joints. Braking system must also be protected (refer to arrows). Commercial aluminum foil may be used for masking.</p>	
<p>3.1 Front wheelhousing</p> <p>Front view</p>	

<p>3.2 Front wheelhousing</p>	
<p>3.3 Front wheelhousing</p> <p>(Entire braking system)</p>	
<p>4.0 Rear wheelhousing</p> <p>a) Mask all rubber joints. Braking system must also be protected (refer to arrows). Commercial aluminum foil may be used for masking</p> <p>(Entire braking system)</p>	

4.1 Rear wheelhousing

(Entire braking system)

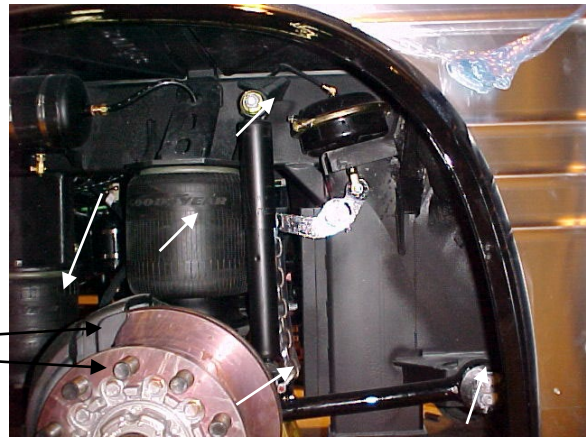

4.2 Rear wheelhousing

(Entire braking system)

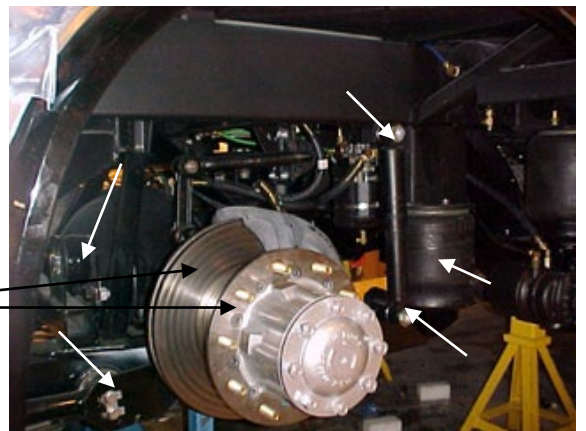

4.3 Rear wheelhousing



5.0 Close off wheelhousing using masking paper.

Prevent rust inhibitor from coming in contact with paint. To close off wheelhousing, a polythene sheet may be used.

6.0 Apply TECTYL 185 GW black rust inhibitor onto wheelhousing mechanical parts.	A spray gun and pumping system are required to apply the rust inhibitor. If the application is done inside a paint room, select high speed ventilation. Minimum required thickness is 10 mils wet or 5 mils dry.
7.0 Remove all masking material 30 minutes after application.	

ANNEX 1

1. Check and confirm that dew point and surface temperature are in accordance with to the following criteria:

Surface temperature > 10°C

Surface temperature > or = to dew point + 3°C

NOTE

Use the following table to determine dew point.

2. Check and confirm that TECTYL temperature is between 10°C and 35°C.

	DEW POINT									
	Relative Humidity (%)									
Temp (c)	10	20	30	40	50	60	70	80	90	100
0	---	-16	-11	-8	-5	-3	-1	0	1	3
1	---	-15	-10	-7	-5	-3	-1	1	2	4
2	---	-14	-10	-6	-4	-1	0	2	3	5
3	---	-13	-9	-5	-3	-1	1	2	4	6
4	---	-13	-8	-5	-2	0	2	4	5	7
5	---	-11	-7	-4	-1	1	3	5	6	8
6	---	-11	-8	-3	0	2	4	6	7	9
7	-18	-10	-6	-2	0	2	5	6	8	10
8	-17	-9	-5	-1	1	4	6	7	9	11
9	-16	-9	-4	-1	2	4	6	9	10	12
10	-16	-8	-3	0	3	5	7	10	11	13
11	-15	-7	-3	1	4	6	9	10	12	14
12	-14	-6	-1	2	5	7	10	11	13	15
13	-14	-6	-1	2	6	8	10	12	14	16
14	-13	-5	0	4	6	9	11	14	15	17
15	-12	-4	1	4	7	10	12	14	16	18
16	-11	-4	1	5	9	11	13	15	17	19
17	-10	-3	2	6	9	12	14	16	18	20
18	-10	-2	3	7	10	13	15	17	19	21
19	-9	-1	4	8	11	14	16	18	20	22
20	-9	0	5	9	12	15	17	19	21	23
21	-8	0	5	10	13	16	18	20	22	24
22	-7	1	6	11	14	16	19	21	23	25
23	-6	2	7	11	15	17	20	22	24	26
24	-6	2	8	12	16	19	21	23	25	27
25	-5	3	9	13	16	20	22	24	26	28
26	-4	4	10	14	17	20	23	25	27	29
27	-4	5	11	15	19	21	24	26	28	30
28	-3	6	11	16	19	22	25	27	29	31
29	-2	6	12	17	20	23	26	28	30	32
30	-1	7	13	17	21	24	27	29	31	33
31	-1	8	14	19	22	25	27	30	32	34
32	0	9	15	20	23	26	29	31	33	35

7. FIBERGLASS REPAIR

All repairs to fiberglass parts consist of filling the damaged area with fiberglass cloth and resin or strand fiberglass and resin. The repair is allowed

to harden, and then finishing operations may be performed. Use of the various materials is determined by the type of repair to be made. Large holes, torn sections and separate joints require the adhesive qualities of the resin and the reinforcing qualities of the fiberglass.

Small dents, scratches or pits can be repaired using resin and strand fiberglass and filler mixed into paste. Instructions for either mix are explained under their respective headings in this section. For best results when making repairs, temperature should be between 70 and 75 °F (21-24 °C). Some people experience a skin reaction to resins. In such cases, wipe resin off with denatured alcohol or a good thinner. Use of protective hand cream is recommended.

	<h2>WARNING</h2>
<p>Always wear a respirator and goggles when grinding or sanding.</p>	

Extreme care must be taken if the sander is electrically operated, as dust from some resins is combustible when subjected to sparks or open flames. The proper tool for sanding resin is a low speed, air driven disc sander with a water attachment or a dry sander having a vacuum bag. Either will eliminate flying glass and resin dust.

The following additional tools and materials will assist in making repairs: hacksaw blade, assorted files, emery paper or cloth (150 or finer), scissors or tin snips, wax paper or cellophane sheets, a 3" (75 mm) paint roller, paint brush, putty knife, acetone and one or more heat lamps.

7.1 REPAIR USING FIBERGLASS CLOTH

Where necessary, sand paint away around damaged area and scrape away undercoating, if any, and wipe clean with solvent. Grind or file the damaged area to form a "V" at the broken or cracked portion. Sides of "V" should have a shallow pitch for maximum bonding area.

<p>NOTE</p> <p><i>Roughening the surface improves adhesion of resin.</i></p>

If part is warped from original shape, use clamping equipment to straighten the surface. Preheat area to be repaired with one or two heat lamps placed 18 to 24 inches (450-610 mm) from repair.

	<h2>CAUTION</h2>
<p>Temperature should not exceed 140 °F (60</p>	

<p>°C) during 30 minutes in order to avoid distortion.</p>
--

Cut fiberglass cloth with scissors or tin snips, 1 to 3 inches (25-75 mm) larger than area to be repaired. Build area to desired height.

Mix resin and hardener following instructions on their containers. Saturate layers of fiberglass with mixture and place laminates over damaged area. Smooth out wrinkles and make sure general contour of area is maintained. Bubbles and wrinkles can be eliminated with a roller.

	<h2>CAUTION</h2>
<p>The pot life of the mix is approximately 15 minutes. Any accidental contamination to the skin, clothing, tools, etc. must be removed within this period. Use acetone to remove uncured resin.</p>	

Heat resin material again by placing heat lamps 18 to 24 inches (450-610 mm) from repaired area. Allow 12 to 15 minutes for repair to cure. After repair is cured, grind, file or sand to contour. Files other than body files may be more suitable. Featheredge and finish sanding.

If small pits or irregularities appear after making repair, correct by using a liberal amount of chopped strand or filler mixed with resin to form a paste. Refer to heading "Repair with Fiberglass Paste" in this section.

7.2 REPAIR USING FIBERGLASS PASTE

Fiberglass paste is used for repairing small dents, scratches, and pits. Paste is made by mixing resin, hardener and fiberglass strand or filler to the consistency of putty. Where necessary, sand paint away around damaged area. On underside of coach, scrape away undercoating from damaged area, and wipe clean with solvent.

Preheat the area to be repaired using heat lamps. Mix desired quantities of resin and hardener according to manufacturer's instructions. Add powdered fiberglass strand into mixture to thicken it into a putty state.

<p>NOTE</p> <p><i>If repair is made on a vertical surface, adding powdered filler material to mixture will reduce tendency of hot resin to flow or run.</i></p>
--

Apply the material with a putty knife or similar object, building material up to the desired contour. For deep filling and on vertical surfaces, several layers of material may be used.

A hacksaw blade, held flat to adjacent contour and then moved in a sawing action across the repair when the resin is in a gel state, will remove excess resin from repair. Finish repair with the same procedure as when using fiberglass cloth.

7.3 TYPICAL FIBERGLASS REPAIR PROCEDURE

Remove all loose particles or damaged material using a power sander or rasp. Clean area, overlapping hole approximately 1" to 1-½" (25-40 mm) all around. Remove all dirt, grease and paint from area to ensure good bonding surface. Feather the cleaned area all around (Figure 3).

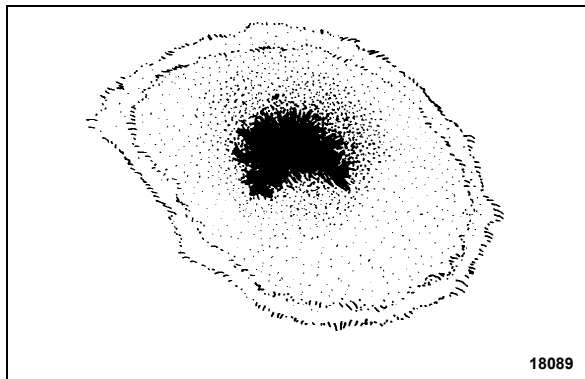

FIGURE 3: FIBERGLASS REPAIR

Cut a piece of fiberglass mat slightly larger than area being repaired. Impregnate mat with general purpose polyester resin catalyzed normally. Use a clean paint brush to apply the polyester resin. Apply impregnated mat over hole and press onto surface with brush to obtain good adherence. Another coat of general purpose polyester resin can be applied at this time (Figure 4).

NOTE

Remove all air between surfaces being joined. Allow area to harden and sand surface to remove any wax.

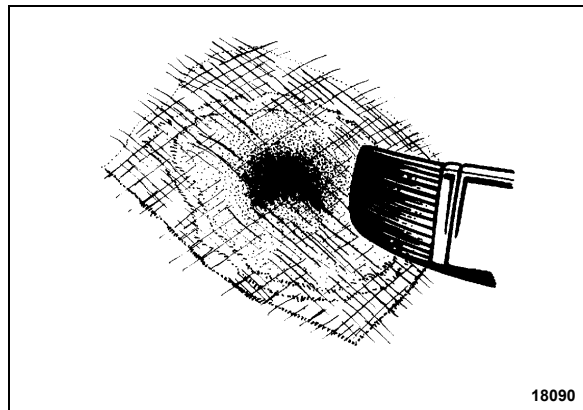

FIGURE 4: FIBERGLASS REPAIR

Apply another mat, followed by a cloth patch, and another mat. All layers must be thoroughly impregnated with polyester resin, brushed well and free of air. Apply more layers of mat and cloth as required until the desired strength and thickness is obtained, minimum two 1-½ oz (43 g) mats and one 9 oz (255 g) cloth (Figure 5).

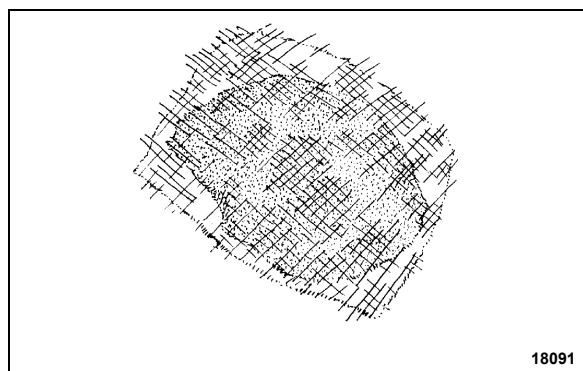

FIGURE 5: FIBERGLASS REPAIR

Allow area to harden and contour the area with coarse sandpaper #100 (Figure 6).

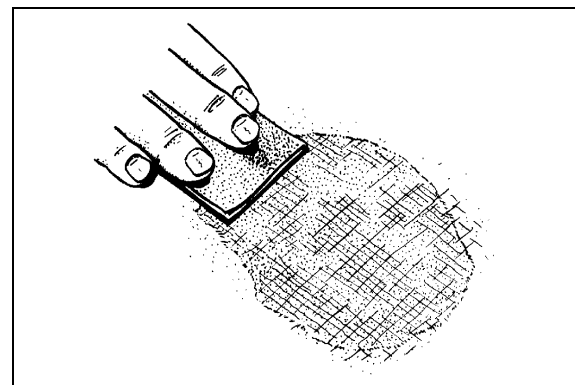

FIGURE 6: FIBERGLASS REPAIR

Cover the area with a layer of resin putty and allow drying for approximately 15 to 20 minutes (FIGURE 7).

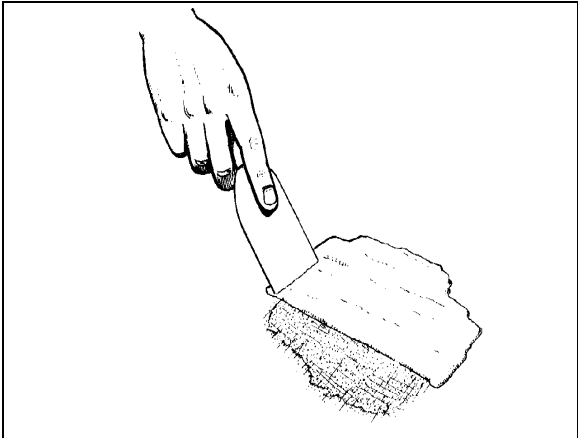



FIGURE 7: FIBERGLASS REPAIR 18093

Smooth off surface with coarse sandpaper #100 to desired shape. Further smooth surface with fine sandpaper #120 until repaired surface matches surrounding area paneling. Prime and paint the area to match surrounding paintwork.

8. PAINTING

8.1 NEW PAINT CARE

Our paint supplier recommends that you follow these simple precautions the first months of your new vehicle's life.

	<p>CAUTION</p>
<p>Apply these recommendations after repainting vehicle.</p>	

During the first 30 days:

- Do not use a commercial bus wash. Stiff brushes or sponges could mar the finish and damage the surface. Wash the vehicle by hand only and with cool water and a very mild bus wash solution. Be careful to use only a soft cloth or sponge;
- Wash vehicle in the shade, never in direct sunlight;
- Do not “dry wipe” vehicle –always use clean water. Dry wiping could scratch the finish;
- Avoid extreme heat and cold. Park vehicle in the shade whenever possible;

- Do not park under trees which drop sap or near factories with heavy smoke fallout. Tree sap and industrial fallout may mar or spot a freshly painted surface;
- Trees are also likely to attract birds. Bird droppings are highly acidic and will damage a freshly painted surface. Bird droppings, tree sap and industrial fallout should be washed off as soon as possible;
- Do not spill oil, gasoline, antifreeze, transmission fluid or windshield solvent on new finish. IMMEDIATELY rinse off any such spill with clean water, DO NOT WIPE;
- Do not drive on gravel roads. Paint finish easily chips during the first 30 days;
- Do not scrape ice or snow from the surface. A snow scraper can act like a paint scraper if the finish is new. Brush off loose material with a soft snow brush.

During the first 90 days:

- Do not wax or polish the vehicle. This will allow the finish to dry and harden completely.

8.2 PAINT TOUCHUP

When paint touchup or partial repainting is necessary, refer to the vehicle's paint scheme for color codes and paint brand.

Prevost recommends using the original paint brand to ease color matching.

In the event you sand through to the gelcoat surface you should prime the area with Standox “Non Stop Fill Primer (ST-11000)”.

If you sand through to metal surface, first prime with Standox “Etch Primer (ST-11858)” then with Standox “Non Stop Fill Primer (ST-11000)”.

	<p>CAUTION</p>
<p>Be sure to heed all paint manufacturer's recommendations, especially concerning paint dilution and application.</p>	

8.3 PAINTING

The standard paint used on the exterior of the vehicle is Standox Basislack. It is a high gloss

polyurethane enamel finish designed for exposure to extreme conditions. Other types of paint may be called for as options by owner but are not dealt with in this section.

8.3.1 Safety

Care should be exercised in storing, handling, mixing, and applying paint and chemicals listed in this manual. The topcoat, primer, solvent, catalysts, accelerators, and cleaners are highly volatile and/or toxic if not properly used. Observe all safety instructions marked on the different packagings, as well as the following:

1. Do not smoke in the paint room or in adjacent area exposed to residue fumes.
2. Wear respirators approved by the governing safety and health regulations.
3. Maintain adequate ventilation at all times.
4. Dispose of any leftover paint mix properly.
5. Wear rubber gloves, rubber apron, and face shield during all phases of paint and chemical handling.

8.3.2 Surface Preparation and Paint Application

	Aluminum and / or Stainless Steel	Fiberglass	Comments
Surface Preparation	Sand using P-150 grit sandpaper. It is recommended to sandblast rivets and panel edges with OLIMAG 35-70 blast media.	Sand using P-180 or P-240 sandpaper.	Do not use paint remover over aluminum or fiberglass.
Cleaning	STANDOX silicone remover ST-11654 (68-2989)		
Priming	STANDOX Reactive Etch Primer ST-13908 * Wait 30 minutes then apply STANDOX Non-Stop Füllprimer ST-11000 (68-2973)	STANDOX Non-Stop Füllprimer ST-11000 (68-2973)	Refer to product Technical Data sheet for proper mixing
Basecoat	Refer to paint scheme or coach record for proper color code and paint brand. We recommend using the same paint brand to ease color matching.		Refer to product Technical Data sheet for proper mixing
Clearcoat	STANDOX 2K MS Rapid Clear ST-11760 (68-2979) Allow 16 hours for drying		Refer to product Technical Data sheet for proper mixing

If assistance or technical information on STANDOX products is needed, please dial: 1 (800) 551-9296

8.4 FRONT AND REAR BUMPERS

8.4.1 Paint touchup and surface preparation for vehicles equipped with urethane bumpers

	COMMENTS	VIP	COACHES
Cleaning	Clean using red wool and Standoflex 11100 (ST-11425) thinner	YES	YES
	Clean again twice using Standoflex 11100 (ST-11425) thinner	YES	YES
Priming	Apply Non-Stop primer (ST-13320) with flexible agent dilution 2:1 10% in 2 or 3 coats, 15 min. flash/off between coats	YES	YES
Sanding	Sand Non-Stop primer using P-320 grit sandpaper	YES	YES
	Use a tack cloth	YES	YES
Basecoat	Apply basecoat. Wait 30 minutes.	YES	YES
Varnish dilution	Dilution without flexible agent	YES	YES
Varnishing	Apply varnish	YES	YES

If assistance or technical information on STANDOX products is needed, please dial: 1 (800) 551-9296

9. FRONT AND REAR BUMPERS

9.1 FRONT BUMPER REMOVAL AND INSTALLATION

The front bumper is hinged to give access to the spare wheel compartment. Bumper must first be tilted down before its removal. Two people are required to remove and install the front bumper.



WARNING

Front bumper weighs approximately 180 lbs. (80 kg). Use proper lifting equipment to support the bumper during the removal and installation operations to avoid personal injury.

Pull on the release handle located in the front electrical and service compartment. The bumper assembly will lower gradually.

9.1.1 Front Bumper Removal

Loosen 12 attaching bolts from inside the bumper, 6 over and 6 under the bumper beam (Figure 8). Let the bumper rest face down on the lifting equipment platform.

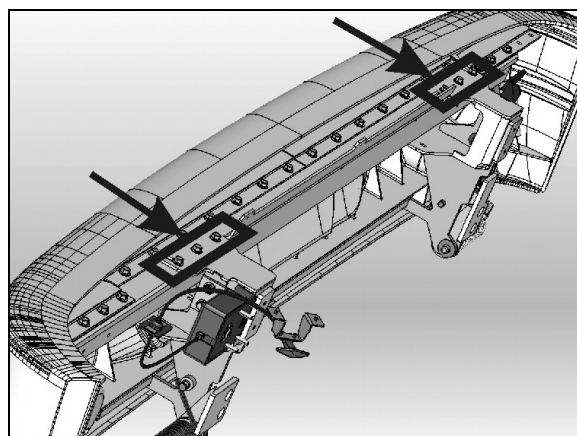

FIGURE 8: BUMPER ATTACHING BOLTS 18498

To reinstall the front bumper, reverse the procedure.

9.1.2 Front Bumper Skin Removal

The bumper skin is pinched to the bumper beam by the use of aluminum extrusions bolted over and under the beam. First, remove the front bumper as per “Front Bumper Removal”. Let the bumper rest face down on the lifting equipment platform. Loosen the aluminum extrusion bolts as required and then detach the skin from the beam (Figure 9).

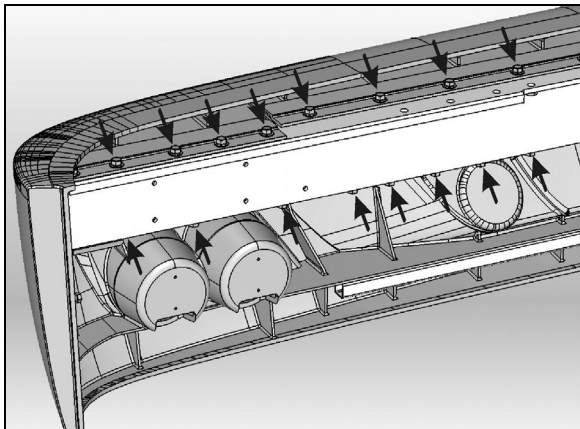

FIGURE 9: ALUMINUM EXTRUSIONS - BUMPER SKIN REMOVAL

9.1.3 Front Bumper Assembly Removal including spare wheel compartment door.

1. Ask assistant to relieve spring tension with assistant proper tool, and relieve spring tension on one locking pin and remove it. Slowly release spring tension and remove the second locking pin. The spring is free. Repeat procedure for the other spring.

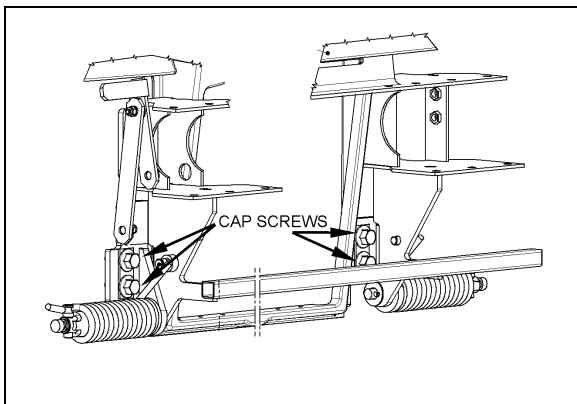

FIGURE 10: FRONT BUMPER ASSEMBLY

NOTE

A special tool kit is available from Prevast: Kit # 410671 including tool #410708.

2. Remove 4 cap screws holding bumper to vehicle and remove bumper (Figure 10).
3. To install bumper, reverse the removal procedure.

9.2 FRONT BUMPER LICENSE PLATE SUPPORT INSTALLATION

License plate supports are stored in the first baggage compartment. Install supports as per Figure 11.

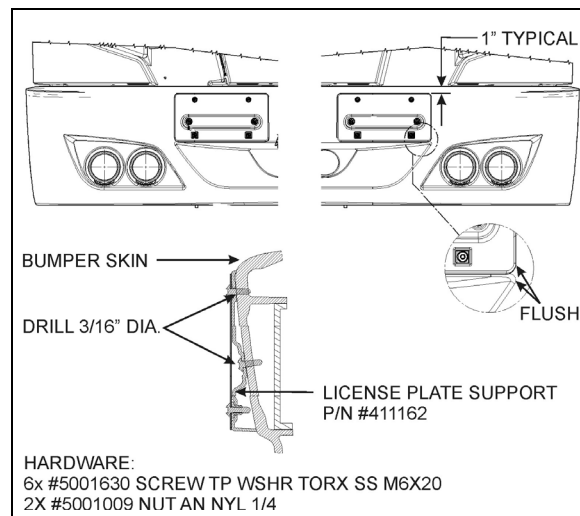

FIGURE 11: LICENSE PLATE SUPPORTS 18500A

9.3 REAR BUMPER REMOVAL AND INSTALLATION



WARNING

Rear bumper weighs approximately 180 lbs. (80 kg). Use proper lifting equipment to support the bumper during the removal and installation operations to avoid personal injury.

1. Remove 6 nuts (3 on each side) holding bumper assembly to vehicle and remove bumper (Figure 12).
2. Let the bumper rest face down on the lifting equipment platform.
3. To install bumper, reverse the procedure.

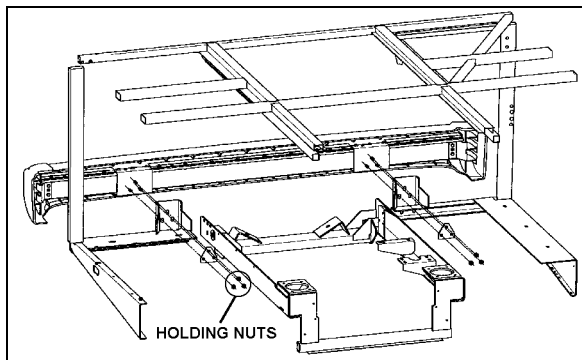

FIGURE 12: REAR BUMPER ASSEMBLY 18501

10. COACH ENTRANCE DOOR

An air operated “sedan type” entrance door, with an air door cylinder and damper assembly are installed under the right hand dash. The opening and closing door speed cycle is adjustable by a damper mounted in parallel with the door cylinder on the door hinge (Figure 15). Door activation is controlled by a relay panel, located near the defroster and wiper motors. The accessory air reservoir supplies air to this system.

The door is held in the closed position during coach operation by two air cylinder locking mechanisms (Figure 16). Air cylinders with return spring in the cylinder body are used. Air cylinders are controlled by an electrically operated solenoid valve energized by a rocker switch located under the right hand dashboard.

To open the door, initial movement of the rocker switch de-energizes the air lock solenoid valve, venting the door locking cylinders. The return locking spring pulls the door lock away from the latch, unlocking the door. Door movement starts only when pressure in the central air door lock is below 10 psi. The “air cylinder open solenoid valve” opens and allows air to flow to the door cylinder, “the air cylinder close solenoid valve” exhausts air from the rod side of the cylinder.

To close the door, initial movement of the switch energizes the “air cylinder close solenoid valve” and air flows to the cylinder by its rod side port. The “air cylinder open solenoid valve” exhausts air from cylinder. When entrance door latch is grounded with the door frame, the air lock solenoid valve is de-energized and loads the door lock cylinders. The cylinder moves the door lock in a position which engages a latch on the entrance door, holding the door positively closed.

Emergency exit valves, which open the air valve circuit, should be used only in emergencies, or when the door control system does not function properly.

Refer to the air system schematic and page 22 of the wiring diagram available on the [technical publications web site](#).

10.1 OPERATION

The air-operated door is controlled from inside the coach by two push-button switches located on the R.H. dashboard.

Opening and closing of the door from outside the coach is accomplished by a momentary toggle switch located behind the coach model nameplate (Figure 13).

To close the door, the switch must be pushed towards the rear of the coach and held in position until the door has completed its movement.

To open the door, the switch must be pushed towards the front of the coach and held in position. When the door reaches the fully opened position, the system will keep pressure in the cylinder locking the door in that position. The door can be stopped in any position by releasing the switch. The door is not locked in position when not fully opened or closed.

If the door has been locked with the key, a lever on the door can be moved to unlock.

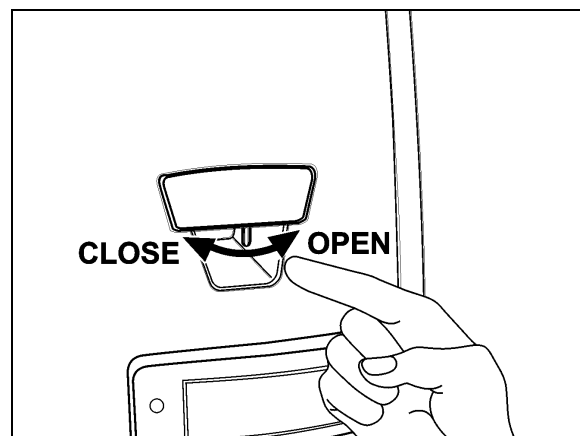

FIGURE 13: DOOR OPERATING SWITCH 18316

10.2 EMERGENCY EXIT VALVES

From inside the vehicle, an emergency exit valve located near the door on the dash panel,

releases the pressure from the lock cylinders. From the exterior, an emergency exit valve located in the front service compartment, also releases the air from the lock cylinders.

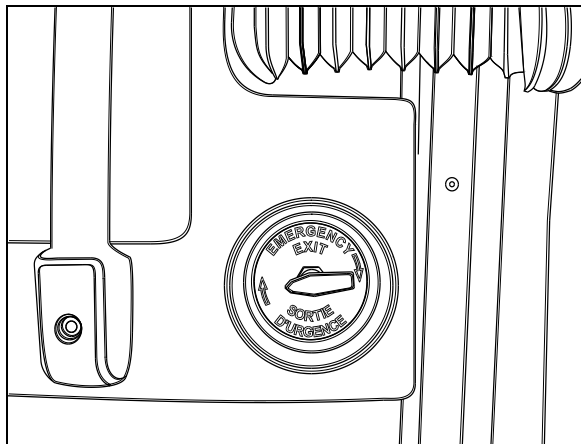

FIGURE 14: EMERGENCY EXIT VALVE 18321

10.2.1 Without Air and/or Without Electricity

If the air pressure drops while coach has or hasn't any electricity, the spring loaded cylinders will unlatch the door. In such a case, unlock the door by moving the lever on the door or by using the key, then open the door manually.

10.2.2 With Air but Without Electricity

From inside the vehicle, turn the emergency exit valve to the "UNLOCK" position. Move the lever. From the exterior, turn the emergency exit valve to the "UNLOCK" position. Open the door. Close it, lock with the key and reset the outside emergency exit valve to the "NORMAL" position.

10.3 DOOR CYCLE SPEED ADJUSTMENT

To do any adjustment, remove the two panels located next to the door hinge, as well as the door's upper hinge control.

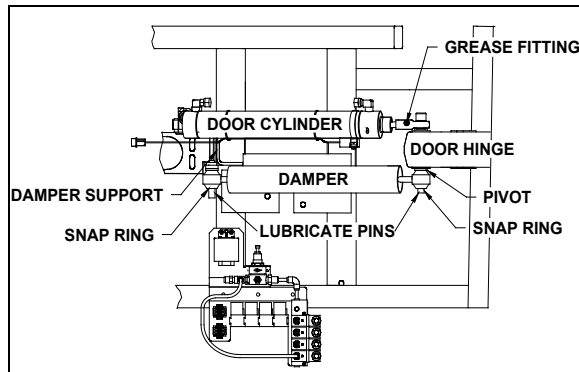

FIGURE 15: DOOR CYLINDER AND DAMPER 18161



CAUTION

It is important to make sure that damper does not reach end of stroke when door is completely closed or opened. The door cylinder must stop the door on opening. Screw or unscrew rod end to adjust if necessary.

To adjust opening and closing cycle speed on damper (Figure 17):

1. Remove the damper from the vehicle and hold it vertically with the lower eye or pin attachment in a vice. Use clamp plates to prevent damage.
2. Fully close the damper while turning the dust cap or piston rod slowly CCW until it is felt that the cams of the adjusting nut engage in the recesses of the foot valve assembly (Figure 17).

NOTE

In Figure 17, if there is an indentation (B) in the dust cap (C) and the cover shows two holes (A), the damper is fitted with a bump rubber (D). If so, fully extend the damper and insert a round bar or screwdriver through the holes. Push the bump rubber down and remove. Remove the split plastic collar (E) (if fitted) from the piston rod.

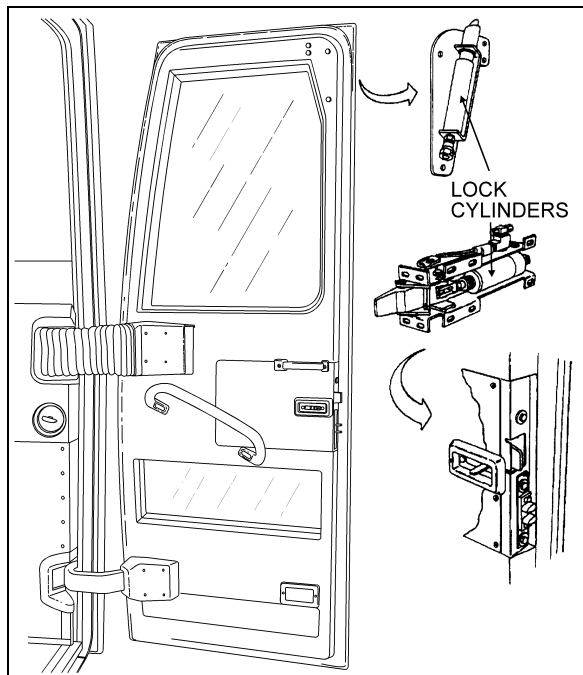

FIGURE 16: COACH ENTRANCE DOOR

18439

3. The damper may have already been adjusted. Therefore check whether the damper is adjusted or not by keeping it closed and gently turning further CCW, counting at the same time the half-turns until a stop is felt. Stop turning and do not force.
4. While keeping the damper closed, make two CW half-turns. In case of prior adjustment, add the number of half-turns previously counted. The total range is about five half-turns.
5. Pull the damper out vertically without turning for at least 3/8" (1cm) to disengage the adjusting mechanism. The dust cap or piston rod may now be turned freely.

NOTE

Where a bump rubber was installed, refit same inside the dust cap and by fully closing the damper, the rubber will seat again at top of the dust cap. Refit the split plastic collar E (Figure 17)

6. The damper can now be refitted in the vehicle.
7. Reinstall panels and entrance door hinge cover.

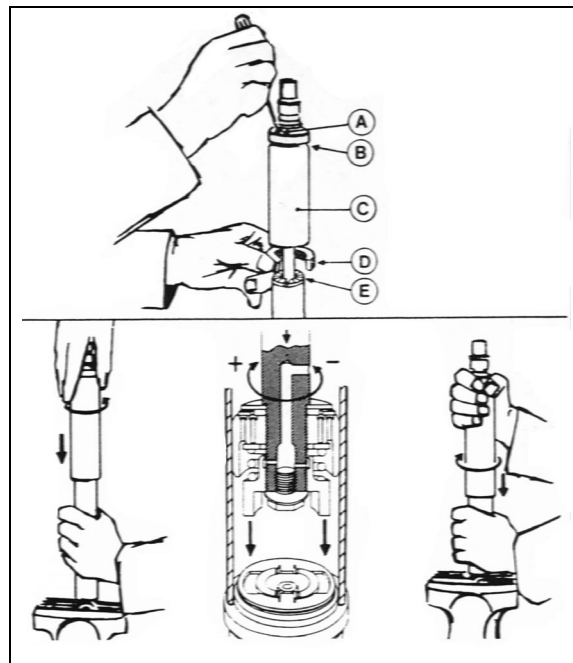

FIGURE 17: DAMPER

10.4 HORIZONTAL AND VERTICAL ADJUSTMENT

Before attempting to correct any door operating problem by adjusting any part of the air cylinder assembly, first perform the following mechanical checks and procedure.

Check around the perimeter of the door for binding. If any binding is found, adjust as follows:

1. Remove the screws and the plastic molding covering each of the hinges.

NOTE

Ask an assistant to help you to perform the following adjustments.

2. Remove the Allen button head screw and the washer retaining the rod end with bearing to the upper hinge. See Figure 18.
3. Support the door with a wooden block and a hydraulic jack.
4. Loosen the horizontal bolts retaining the door to the hinges. Adjust the door horizontally and vertically with the jack. Tighten the bolts.

TORQUE: 55-65 lb-ft (75-88 Nm)

5. Remove the jack and the wooden block.

**CAUTION**

Make sure the entrance door does not interfere with the exterior panel.

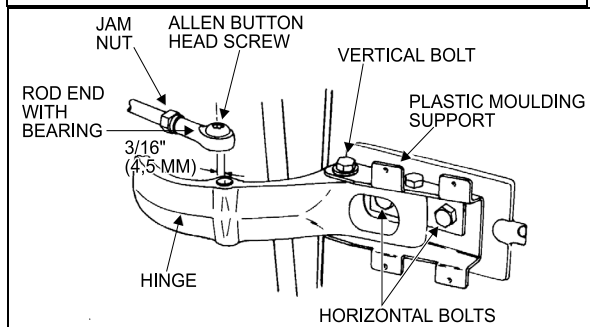

FIGURE 18: UPPER DOOR HINGE (COACH)

18058

6. Pull and fasten the rod end to the hinge with the washer and the button screw.
7. Screw the plastic moldings covering the hinges.

10.5 DEPTH ADJUSTMENT

1. Turn the emergency exit valve to the "UNLOCK" position.
2. Remove the screws and the plastic molding covering each of the hinges.

NOTE

Ask an assistant to help you to perform the following adjustments.

3. Remove the Allen button head screw and the washer retaining the ball and socket rod to the upper hinge. See Figure 17.
4. Loosen the vertical bolts on the hinges for the front section, and for the rear section, move the central door catch on the door frame.
5. To adjust the male dovetail on L.H. side of the door, remove the two screws and loosen the two bolts. Slide the male dovetail toward the interior and loosely tighten the two bolts. Close the door slowly but firmly, then slowly open it and tighten the two bolts. Attach dovetail to the door with screws. See Figure 19.

NOTE

The frame dovetail is not adjustable.

6. Pull and fasten the rod end to the hinge with the washer and the button screw.
7. Using the screws, attach the plastic moldings covering the hinges.
8. Reset the emergency exit valve to the normal position.

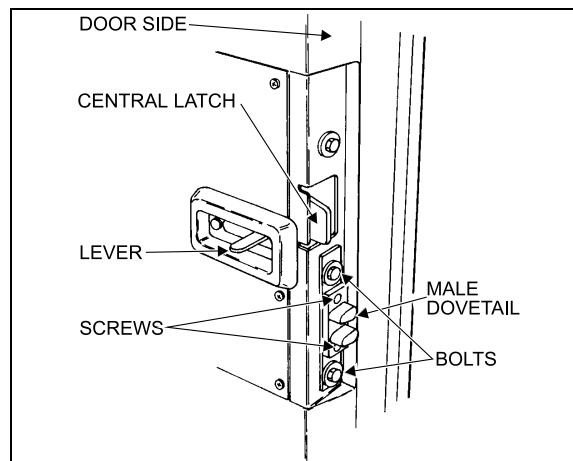

FIGURE 19: DOOR LATCH (COACH)

18059

10.6 ROD END ADJUSTMENT

1. Turn the emergency exit valve to the "UNLOCK" position.
2. Remove the screws and the plastic moldings covering the upper and lower hinges.
3. Remove the Allen button head screw and the washer retaining the rod end with bearing to upper hinge. See Figure 17.
4. Loosen the jam nut locking the door cylinder rod end. Close the door firmly, adjust the rod end center hole in order to be 3/16" (4,5 mm) eccentric toward the left with the hinge hole center. Tighten the jam nut.
5. Pull and fasten the rod end to the hinge with the washer and the button screw.
6. Using the screws, attach the plastic moldings covering the hinges.
7. Reset the emergency exit valve to the normal position.

10.7 LUBRICATION

Part	Lubricant	Frequency
Latches Upper door catch Door cylinder rod end with bearing grease fitting (Figure 19)	Low temperature grease	Every six months
Door locking mechanism	White grease	Every six months

10.8 TROUBLESHOOTING

SYMPTOM	PROBABLE CAUSE	REMEDY
DOOR WILL NOT OPEN FROM EXTERIOR SWITCH.	Manual door locks engaged.	Release manual door locks.
	Upper and lower solenoid locks do not disengage.	Check voltage at solenoid locks when door is open. If the voltage is 24 volts then replace solenoid #641217. Else, check circuit power.
	Relay module do not receive current.	Reset breaker "ON" or check batteries power supply.
	Opening solenoid door does not receive current.	Check voltage at opening solenoid door. If the voltage is 24 volts then replace it. Else replace control relay.
	Switch malfunction.	Replace switch.
DOOR WILL NOT CLOSE FROM EXTERIOR SWITCH.	Switch malfunction.	Replace switch.
	Solenoid failure.	Check voltage at solenoid. If the voltage is 24 volts then replace solenoid. Else replace control relay.
DOOR WILL NOT OPEN FROM INTERIOR SWITCH.	Manual door locks engaged.	Release manual door locks (open position) from vehicle exterior.
	Upper and lower solenoid locks do not disengage.	Check voltage at solenoid locks when door is open. If the voltage is 24 volts then replace solenoid #641217. Else, check circuit power and replace control relay.
	Module relay does not receive electric current.	Reset breaker "ON" or check batteries power supply.
	Door opening solenoid does not receive current.	Check voltage at door opening solenoid. If the voltage is 24 volts then replace it. Else replace control relay.
	Switch malfunction.	Replace switch.
	Upper lock stays engaged.	Lubricate upper lock assembly. Check wear and replace parts if necessary.
DOOR WILL NOT CLOSE FROM INTERIOR SWITCH.	Switch malfunction.	Replace switch.
	Door closing solenoid does not receive electric current.	Check voltage at door closing solenoid. If the voltage is 24 volts then replace it. Else replace control relay.
DOOR WILL NOT OPEN AFTER DRAINING AIR FROM SYSTEM BY EMERGENCY VALVE(S).	Manual door locks engaged.	Release manual door locks (open position) from vehicle exterior.
	Damper cylinder blocks the door.	Adjust or replace damper cylinder.
	The upper lock blocks the door	Adjust lower lock. Lubricate upper latch bolt. Adjust upper latch height.
DOOR LOCKS STAY ENGAGED WHEN DOOR IS OPEN.	Power supply is cut at solenoid.	Place switch in open position.
	Solenoid lock does not disengage.	Check voltage at solenoid locks when door is OPEN. If the voltage is 24 volts then replace solenoid #641217. Else, check circuit power and replace control relay.
DOOR DO NOT LOCK WHEN DOOR IS CLOSED.	Emergency valve is open.	Close emergency valve.
	Lock solenoid stays electrified.	Check latch bolt ground on door frame. If needed clean locks for better contact. Check ground circuit.
	Lock solenoid works in reverse.	Reverse air hoses at solenoid locks.
	Relay does not function.	Replace relay.

11. ENTRANCE DOOR (V.I.P)

There are three ways of unlocking the entrance door from the inside of vehicle. The two first consist in actuating the rocker switch on the dashboard, but this last operation will also unlock the baggage compartments. Finally, you can unlock the door by sliding its lock lever to the left. If the orange tab on the door lock lever is visible, the door is unlocked.

You may lock/unlock the entrance door from the outside with the lock key provided with the vehicle. Turn key CCW to lock and CW to unlock the entrance door.

11.1 KEYLESS ENTRY SYSTEM

With this system, you can lock or unlock the entrance door as well as the baggage and service compartment doors. The keyboard is located below the entrance door handle. The module is pre-programmed by the manufacturer and this code can not be deleted. Moreover, you can program your own entry code. Refer to the "VIP Owner's Manual" for instructions on how to program your own entry code.

When you use the keyless entry system, the keyboard and stepwell lights illuminate. Do not push the buttons with a key, pencil or any other hard object as it could damage the buttons.

Although each button is provided with two digits separated by a vertical line, there is only one contact per button. Always press the center of the button (between the two digits, on the vertical line).

If you let more than five seconds pass between each button press, the system shuts down, and you have to enter your code again. If the keyless entry system does not work properly, use the key to lock or unlock entrance or compartment doors. To know more about the keyless system, refer to the "VIP Owner's Manual".

NOTE

You must unlock the entrance door before you unlock with the appropriate key any baggage or service compartment doors.

11.2 DOOR ADJUSTMENT

Check around the perimeter of the door for binding. If any binding is found, adjust as follows:

11.2.1 Horizontal and Vertical Adjustments

1. Remove the screws and the plastic molding covering each of the hinges.

NOTE

Ask an assistant to help you to perform the following adjustments.

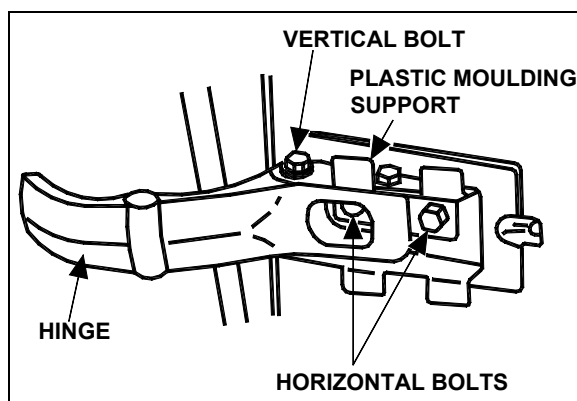

FIGURE 20: ENTRANCE DOOR (VIP)

18058VIP

2. Support the door with a wooden block and a hydraulic jack.
3. Loosen the horizontal bolts retaining the door to the hinges. Adjust the door horizontally and vertically with the jack. Tighten the bolts to

TORQUE: 55-65 lb-ft (75-88 Nm)

Remove the jack and the wooden block.

4. Check door fit.
5. Using the screws, fasten the plastic trim to cover the hinges.

11.3 DEPTH ADJUSTMENT

To adjust door depth on the hinged side:

1. Remove the screws and the trim covering each of the hinges.

NOTE

Ask an assistant to help you to perform the

following adjustments.

2. Slightly loosen, but not completely the vertical bolts on both door hinges.
3. Ask your assistant to press the door from the exterior, until it will adjust with the vehicle structure. Then, tighten the vertical bolts.
4. Repeat step 3 until depth is corrected to satisfaction.
5. Using the screws, install the trim hiding the hinges.

To adjust door depth on lock side:

Depth adjustment is done by moving the two door striker pins.

1. Slightly loosen the door striker pins.
2. Ask your assistant to press the door from the exterior, until it will adjust with the vehicle structure. Then tighten the striker pin.
3. Repeat until the door depth is corrected to satisfaction.

11.4 DOOR LOWER SECTION

When a plastic door lower section replacement is needed, proceed the following way:

1. Remove the reflective stripe at the top edge of the door's lower section. Unscrew the retaining screws located under the reflective stripe.
2. Remove the lower section.
3. With a sharp edge knife, scrape as much tape as possible and compound left on the fiberglass door surface. Note where adhesive tape and sealing compound was applied.
4. Sand the surface of the door where new adhesive tape will be applied with 240 grit sandpaper.

NOTE

Tape adheres best to smooth surfaces such as glass or gelcoat finishes. Be careful surface is as smooth as possible before applying tape.

5. Clean contact surfaces with alcohol.

6. Clean the fiberglass door and the new plastic lower section with a "tack cloth". Make only one pass on the surface and never come back on a previously cleaned surface.



WARNING

Wear rubber gloves and do not smoke when cleaning.

7. Prepare the door lower section with Sika #205 and a clean rag. Make only one pass on the surface and never come back on a previously cleaned surface.

NOTE

Never use Sika #205 directly from the container to avoid contamination of the product.

8. Wait at least 5 minutes before preceding the next step to allow complete evaporation of the product.
9. Put new adhesive tape where it was previously applied. Pass a 1" (25mm) roller on it to get a good adhesion on the fiberglass.
10. Apply Sika #252 (Prevost #682462) compound where it was previously applied.
11. Remove protective paper from the adhesive tape and install the door lower section. Apply pressure with a roller where the lower door section touches the fiberglass door.
12. Replace the retaining screws.

11.5 REFLECTOR STRIPE INSTALLATION

1. Clean contact surfaces with alcohol.
2. Prepare surface of reflector stripe and door lower section with Sika #205.
3. Put two rows of adhesive tape on the lower door section.
4. Apply Sika #252 (Prevost #682462) compound between parallel tape stripes.
5. Remove protective paper from the adhesive tape and press the reflective stripe in place.

11.6 DOOR SEAL REPLACEMENT

1. Inspect the seal; if cracked or torn, it must be replaced:
2. Remove the old seal and with a sharp edge knife, scrape tape left on the fiberglass door surface.
3. Sand the surface of the door where a new seal will be applied with 240 grit sandpaper.
4. Clean the surface with alcohol.



WARNING

Wear rubber gloves and do not smoke when cleaning.

5. Peel of protective paper from the seal. Position the seal in order to leave 1/4" (6 mm) from the upper molded edge of the door and 3/16" (4,5 mm) from the sides and lower molded edges of the door.
6. Progress slowly all around the door.
7. Cut the seal and glue both ends with LOCTITE 414 glue.
8. To assure bonding, press a small roller on top of the new seal.

11.7 DOOR LUBRICATION

Part	Lubricant	Frequency
Latches Upper door catch	Low temperature grease	Every six months
Door locking mechanism	White grease	Every six months
Key hole Hinges	Low viscosity oil	Every six months

11.8 DOOR LATCH MECHANISM

Generally, when the latch mechanism malfunctions, a number of causes may be responsible for this situation. No single procedure will correct this situation. It is best to remove the protective cover and to look for binding, used or bent parts. Operate the latch

mechanism and try to find where any binding occurs. Replacing a part or slightly bending a rod should be enough. Remember, having a global understanding of the mechanical activity will generally lead you to the cause of the problem, and ultimately to an easy repair.

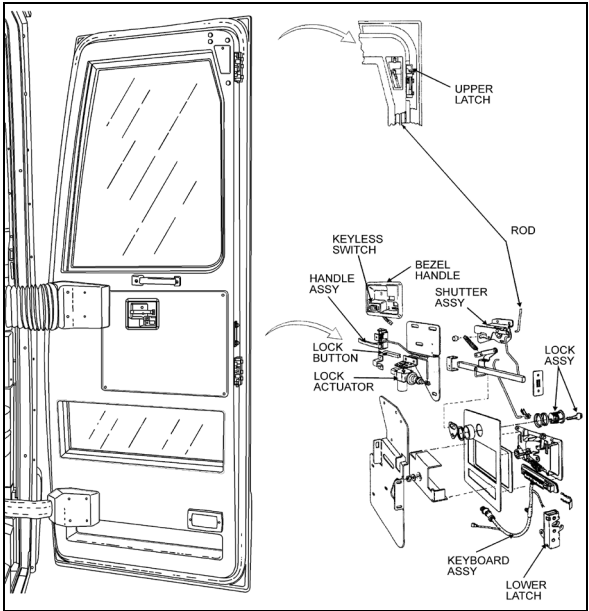

FIGURE 21: ENTRANCE DOOR (VIP, TYPICAL) 18440

12. DRIVER'S POWER WINDOW

To replace window or motor, the whole assembly must be removed. The following instructions refer to Figure 22.

12.1 POWER WINDOW REMOVAL

1. Raise the driver's power window.
2. Set the battery master switch to the OFF position.
3. The window must be held in upper position. To do so, use duct tape to hold it in place.
4. Gain access to the power window mechanism. Dismount the driver's area lateral control panel and left interior trim. It may be required to remove the driver's seat and dashboard panel.
5. Unfasten bolts (item 1) fixing the window to the lifting mechanism (actuator).
6. Remove the three bolts (item 2) holding the motor support and actuator assembly in place.

7. Detach the plastic water protection shield and remove the assembly by slipping it under the vehicle structural members.
8. Dismount the window support and lower the window completely to release it from its guides.
9. Detach the motor and actuator guide from the support and plastic shield. Replace parts as required.

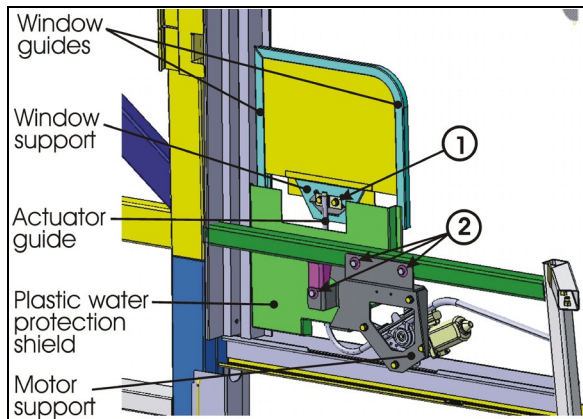

FIGURE 22: DRIVER'S WINDOW

23358

12.2 POWER WINDOW INSTALLATION

1. Energize the motor and position the actuator to its full extended position.
2. Using alcohol, a sharp knife or 240-grit sandpaper, clean off the butyl strip from the shield and frame. Install new butyl strip on plastic shield.
3. Install new window in opening. Use duct tape to hold it in upper position. Fix the window support using bolts recovered from disassembly. Use Loctite on threads.
4. Fasten window support to actuator using the recovered bolts (item 1). Use Loctite on threads.
5. Expose the other sticky side of the butyl strip. Install motor support and actuator assembly using recovered bolts (item 2). Stick plastic shield in place.

13. DASHBOARD – R.H. SIDE PANEL REMOVAL

The panel on the right side of the dashboard is secured with fasteners as seen in Figure 23 and Figure 24.

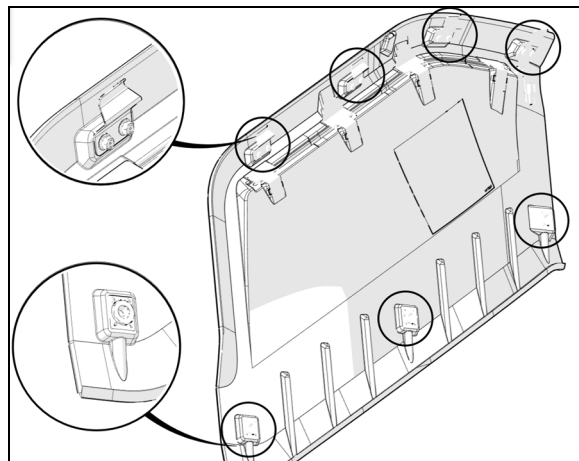

FIGURE 23: ATTACHMENT POINTS AT THE BACK OF THE PANEL

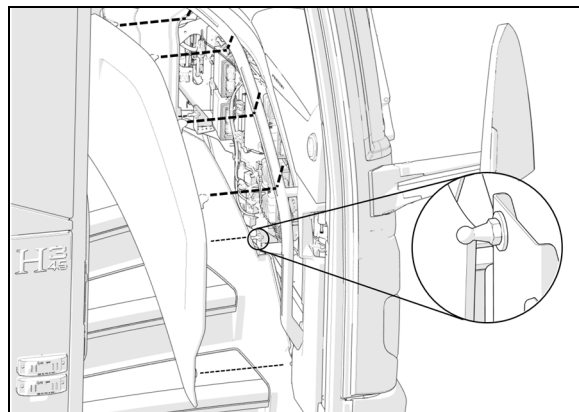

FIGURE 24

To remove the panel, detach the bottom of the panel in three places by pulling towards you and then pull the panel down to disengage the top.

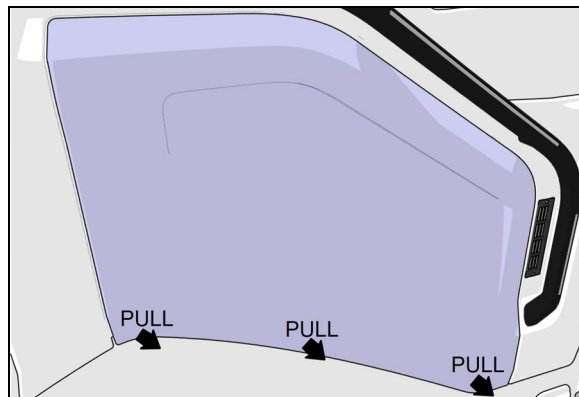

FIGURE 25

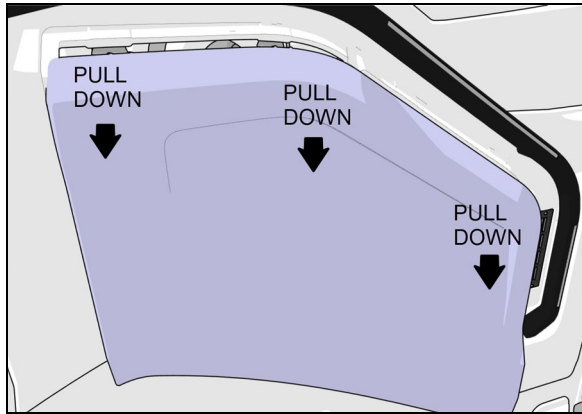

FIGURE 26

14. ROOF ESCAPE HATCH

The vehicle can be equipped with one or two escape hatches. The escape hatch is designed to provide years of reliable service with a minimum of maintenance. All components are rust proof, and moving parts are Teflon coated to eliminate need for lubrication. Should water infiltrate the vehicle from the escape hatch, refer to the heading "Sealing" in this section for procedures on how to seal this area.

	<h3>CAUTION</h3>
<p>Use of lubricants, paints, or other coatings such as graffiti deterring sprays is not recommended.</p>	

Suggested maintenance includes periodic inspection of fasteners for evidence of loosening due to tampering, and regular cleaning with mild soap and water.

Although there are other cleaning solutions available, some contain solvents and other chemicals that can attack the high strength materials used in the production of the escape hatch.

	<h3>CAUTION</h3>
<p>Ensure that cleaning solutions are compatible with the materials used on the escape hatch.</p>	

Graffiti removing cleaners often contain acetone, ether, lacquer thinner or other solvents known to destroy the high strength properties of many plastics. Use of these cleaners must be avoided.

Graffiti-resisting coatings often leave a sticky residue that interferes with smooth up/down movement of the hatch mechanism. Some of these coatings also contain solvents that will reduce the strength of certain components.

	<h3>CAUTION</h3>
<p>Use of these coatings is at considerable risk and should be avoided.</p>	

14.1 REPAIR

All components used in the production of the escape hatch are available as service parts, except for one hinge that represents a possible hazard when improperly reattached to a hidden tapping plate, itself often damaged whenever the hinge is damaged. The tapping plate is permanently laminated between the inner and outer cover assemblies, and it cannot be inspected or replaced. It is therefore necessary to replace the entire assembly following damage to the hinge. See Figure 27 and Figure 28.

	<h3>CAUTION</h3>
<p>Hinge assembly is critical and hinge should never be removed from cover assembly. Fasteners used in this assembly are special and have critical torque requirements and tamper-resistant heads to discourage tampering.</p>	

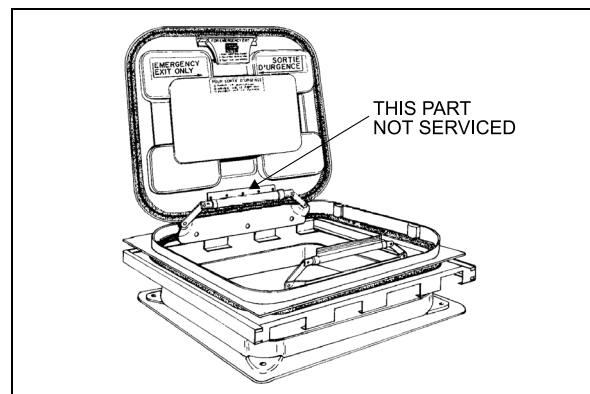

FIGURE 27: ESCAPE HATCH

18104

14.2 SEALING

1. Open and tilt up the escape hatch cover.

2. Join the 2 ends of the rubber seal.

**CAUTION**

Seal joint should be toward rear of vehicle.

3. Apply rubber adhesive CA-40 (Prevost # 681285) in the gap between the seal ends.
4. Apply Sikaflex 221 sealant (Prevost # 680532) along the outline of the escape hatch on the roof of vehicle.

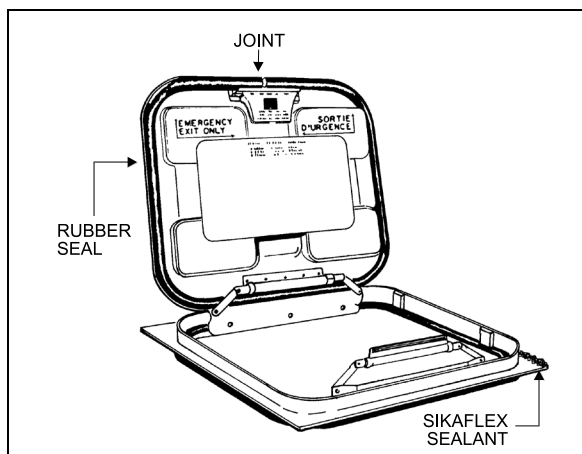

FIGURE 28: ESCAPE HATCH

18105

2. Remove rivets.
3. Cut the rubber seal with a sharp edge knife and remove the hatch frame.
4. On vehicle top, using the knife, remove as much as possible the remaining rubber seal.
5. Drill holes (if needed) in the new metal frame.
6. Clean both vehicle top and new hatch frame with SIKA 205.
7. Apply rubber adhesive SIKA 221 under the hatch frame surface.
8. Install the frame in place and fix it with rivets.
9. Remove excess adhesive and clean all around.

14.3 ESCAPE HATCH PANEL ASSEMBLY

The frame of the escape hatch is riveted to the roof of the vehicle. The escape hatch panel assembly can be replaced as a unit and a new panel assembly installed in the existing frame. To remove the panel assembly, remove the 4 bolts fastening the 2 hinges to the escape hatch frame and retain the 4 flat washers. Reinstall the panel assembly by fastening the 2 hinges with the 4 bolts and flat washers removed earlier.

**CAUTION**

When installing, roof escape hatch's hinge must be toward the front of vehicle, to prevent the hatch from being ripped out if accidentally opened while vehicle is running.

14.4 ESCAPE HATCH FRAME

When necessary, the escape hatch frame can be removed and replaced in the following way:

1. Support the frame from inside the vehicle.

15. REPAIR OR REPLACEMENT OF “TARABUS” FLOOR COVERING

“Tarabus” covering installed in H3 coaches may be replaced or repaired. The purpose of this paragraph is to explain the steps to be followed to ensure the best results and adherence.

MATERIAL

Part No	Description	Qty
680028	Adhesive, Tarabus Floor Covering (White)	A/R
684655	Adhesive, Contact (3M)	3.8L
684654	Adhesive, Contact (3M)	18.9L
680532	Sikaflex 221 Gray	A/R

1. Remove number of passenger seats required to perform repair.
2. Cut and remove damaged section of floor covering.

NOTE

It would be preferable to cut under two rows of seats so that repair is not as noticeable.

3. Clean plywood using a scraper.

NOTE

Make sure that no staples are sticking out beyond surface. Adjacent plywood sheets must be leveled.

4. Fill up holes and imperfections using MAPI PRP 110 then sand.
5. Remove dirt and adhesive residue.



CAUTION

Do not leave floor covering folded down except temporarily during installation.

6. Apply floor covering adhesive (680028) onto plywood using a serrated spreader with 1/8-inch serration. If required, apply contact adhesive (3M) (684655 or 684654) onto aluminum molding and also onto section of floor covering, which will be in contact with molding (refer to Figure 29).

NOTE

Allow adhesive to dry (3 to 5 minutes).

7. Compress floor covering using a roller so as to remove any trapped air bubble.
8. Apply Sikaflex 221 gray sealant (680532) alongside passenger seat fixing tracks (refer to Figure 30).

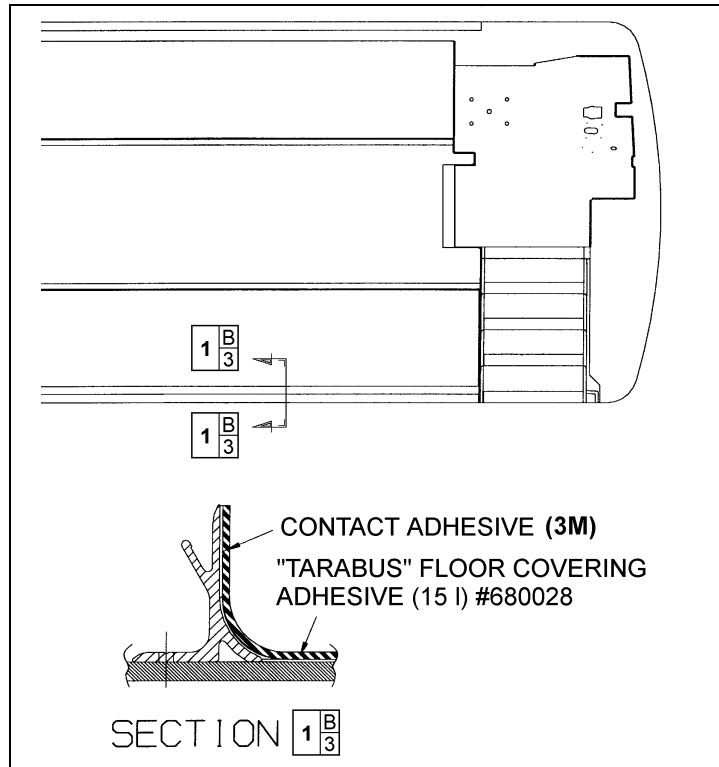

FIGURE 29: TARABUS FLOOR COVERING ADHESIVE APPLICATION

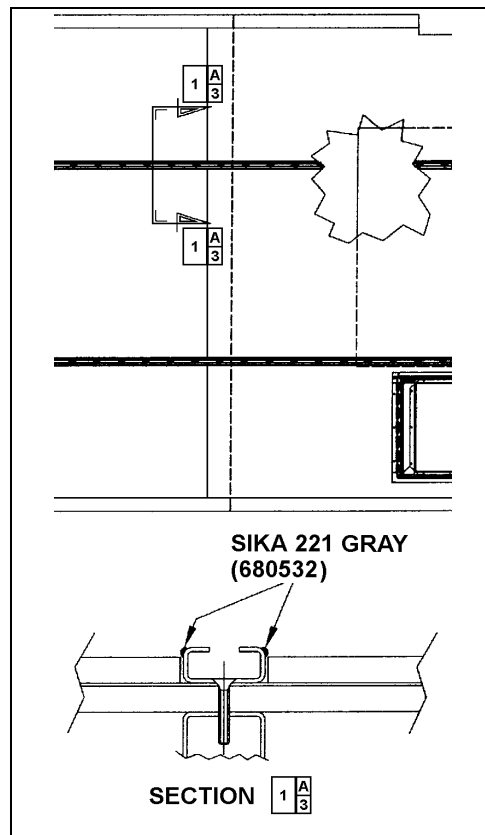

FIGURE 30: APPLICATION OF SIKA 221 GRAY

15.1 FRONT STEPS REPLACEMENT PROCEDURE

MATERIAL

Part No	Description	Qty
682989	Anti-silicone	A/R
683097	Sika 205 (1 liter)	A/R
685101	Sika Remover 208	A/R
683916	Sika 215 (1 liter)	A/R
684654	Adhesive, Contact (3M)	3.8L
684655	Adhesive, Contact (3M)	18.9L
684517	Sealant, gray	A/R

1. Cut and remove damaged step(s).
2. Remove dirt and adhesive residue.

NOTE

In wintertime, condensation and cold temperature may greatly influence bonding parameters. Working area must be at a temperature sufficient to prevent reaching condensation point. Mechanically preheat working area (heat lamp or heat gun) or wait until vehicle reaches room temperature.

PREPARATION OF "TARABUS" FLOOR COVERING

1. Sand under step using "Scotchbrite".
2. Clean using anti-silicone (refer to Section A).

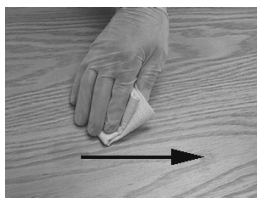
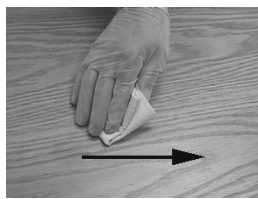
Section A Alcohol or Anti-silicone							
	<p>1. Apply</p> <p>CHIX cloth</p>						
	<p>2. Dry immediately</p> <p>Blue cloth</p>						
<p>3. Allow drying</p> <table border="1" style="width: 100%;"> <tr> <td style="width: 30%;">Mandatory</td> <td>Minimum time : Wait for product to evaporate</td> </tr> <tr> <td></td> <td>After 2 hours: Start cleaning operation again</td> </tr> <tr> <td>Before applying any other product</td> <td>If surface seems dusty, greasy or with finger marks, start cleaning operation again.</td> </tr> </table>		Mandatory	Minimum time : Wait for product to evaporate		After 2 hours: Start cleaning operation again	Before applying any other product	If surface seems dusty, greasy or with finger marks, start cleaning operation again.
Mandatory	Minimum time : Wait for product to evaporate						
	After 2 hours: Start cleaning operation again						
Before applying any other product	If surface seems dusty, greasy or with finger marks, start cleaning operation again.						

3. Apply Sika Primer 215 (refer to Section D).

Section D Sika Primer 215

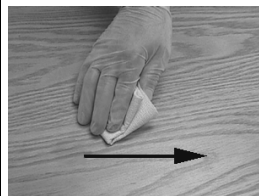

- 1.** Shake bottle to mix product
- 2.** Apply a thin layer

CHIX cloth

3. Allow drying

Mandatory	215	Minimum time : 20 minutes
		After 2 hours : Remove dust using damp cloth (pure water)
Before applying any other product		If surface seems dusty, dust using damp cloth.
		If surface seems greasy or with finger marks, reactivate with Aktivator.

PREPARATION OF FIBERGLASS

1. Clean using anti-silicone (refer to Section A).
2. Apply Sika 205 (refer to Section B).

Section B Sika 205

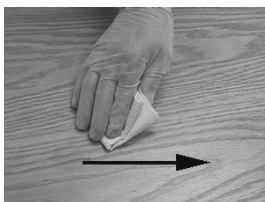

- 1.** Apply

CHIX cloth

2. Allow drying

Mandatory	Minimum time	- For a smooth surface (aluminum, stainless, steel, fiberglass (gelcoat side), etc.):	2 minutes
		- For a porous surface (fiberglass (non gelcoat side), etc.)	10 minutes
After 2 hours : Reactivate surface with Sika 205			
Before applying any other product		If surface seems dusty, greasy or with finger marks, start operation again.	

H3 VEHICLE FRONT STEPS GLUING

1. Remove adhesive tape from underneath step.
2. Apply a thin and even layer of contact adhesive (3M) (684655 or 684654) onto fiberglass and step surfaces. Allow drying for 3 to 5 minutes.
3. Install step beginning with the back and finishing with step nosing. Compress step covering using a roller paying particular attention to corners, edges and front of step.
4. Apply a bead of sealant (684517) around the perimeter of steps. Smooth out the joints.

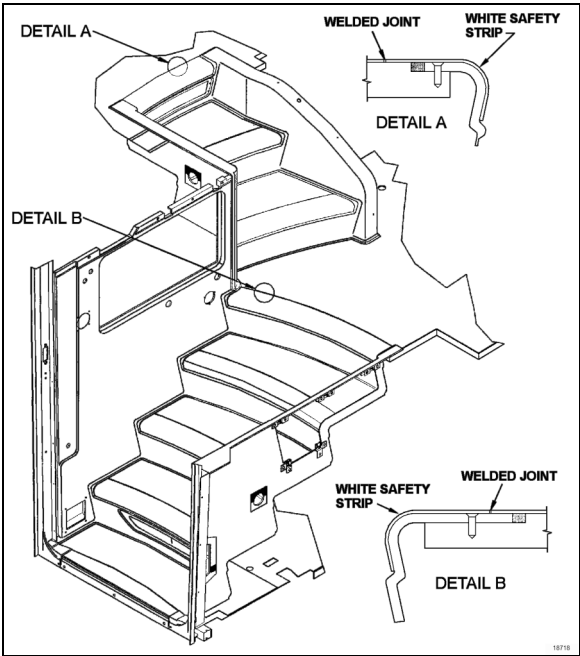
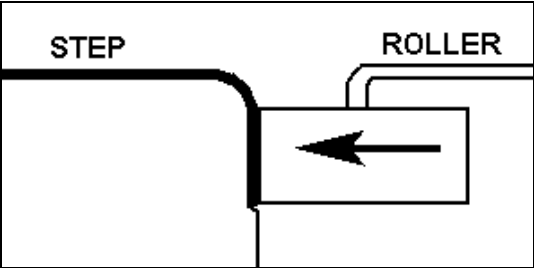

5. Apply contact adhesive (3M) (684655 or 684654) onto both surfaces to glue (fiberglass and back of white safety strip). Drying time: 4 to 5 minutes.

NOTE
There should be no floor covering adhesive (680028) onto plywood before applying contact adhesive, otherwise the two surfaces won't stick.

GLUING OF WHITE SAFETY STRIP BETWEEN STEP AND "TARABUS" FLOOR COVERING

1. Sand fiberglass using "Scotchbrite".
2. Clean using tack cloth.
3. Clean twice using anti-silicone (refer to Section A).
4. Protect surfaces around the step with masking tape.

6. Position white safety strip with reference to "Tarabus" step covering finishing with step nosing. Compress step covering using a roller paying particular attention to corners, edges and front of step.

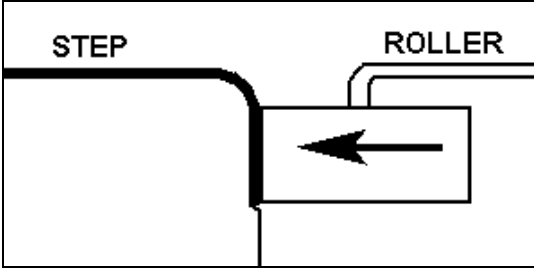

NOTE
 Keep a gap of 1 to 1.5 mm between "Tarabus" covering and white safety strip.

7. Remove masking tape.

15.2 WELDING OF JOINT BETWEEN WHITE SAFETY STRIP AND "TARABUS" FLOOR COVERING

1. Pre-heat welding torch;

Set welding torch to position #4.5 (temperature of 500 °C),

Heating time: 5 minutes.

2. Before welding, visually ensure that a 1 to 1.5 mm gap exists between white safety strip and "Tarabus" floor covering. Use a knife if this is not the case.

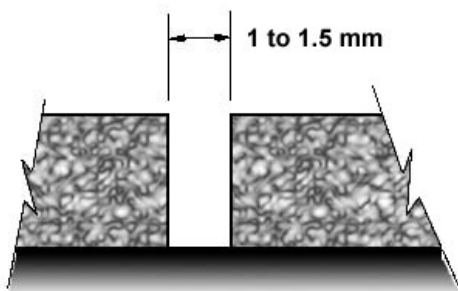

NOTE

There should be no excess of adhesive on top of surfaces, clean if required using "All-Sol".

3. Chamfer the joint.

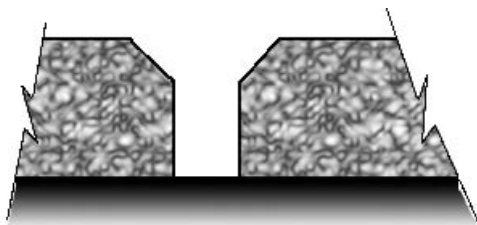

NOTE

The chamfer width must always be less than the filler bead diameter (between 2.5 and 3 mm).

4. Use chamfer knife. **Be careful not to overcut or to cut to the side to prevent damaging "Tarabus" covering.**



5. Add (about 6 inches) some length to the required length of filler bead to make the joint then cut.

6. Take position with welding torch. The proper position is with a slight slope to the rear.



7. Once the welding torch is ready, insert the filler bead into the nozzle and immediately start welding. Move in a regular manner while pressing slightly with torch.



8. The heel of the fast nozzle must not lean against "Tarabus" covering (always parallel to the surface).

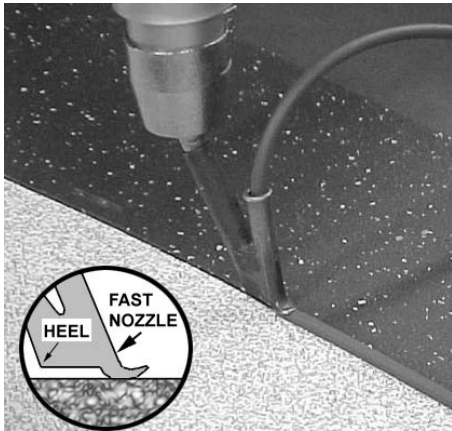

9. Allow cooling down of filler bead (about 5 minutes).

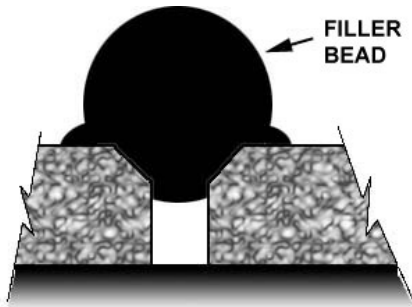

10. Shave filler bead to make it level to the floor. Use supplied knife designed for that purpose.

NOTE
To facilitate the cut, you can spray some soapy water onto the joint.

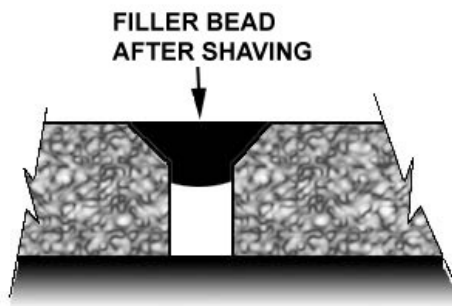

CAUTION
The procedure for turning the torch off must absolutely be followed. If this step is not taken, the element may burn.

11. Set temperature potentiometer to "0" position. Fan will evacuate residual heat. Leave the torch in operation as it is for 3 minutes.

12. Perform adhesion test using the tip of a flat screwdriver; apply a slight pressure on the joint.

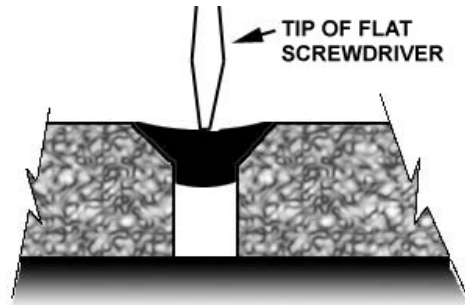

13. If welding was not performed properly, there will be a loss of adhesion on one side. If this is the case, repair the joint.

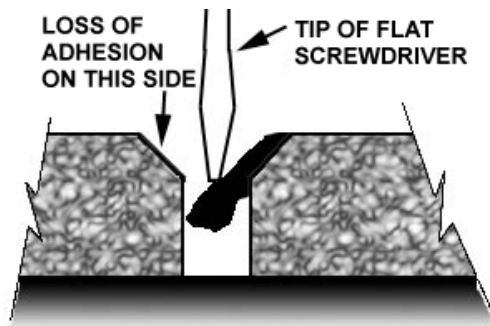

15.3 REPAIR OF A WELDED JOINT

NOTE
In wintertime, condensation and cold temperature may greatly influenced bonding parameters. Working area must be at a temperature sufficient to prevent reaching condensation point. Mechanically preheat working area (heat lamp or heat gun) or wait until vehicle reaches room temperature.

1. Using a knife, remove portion of joint to be repaired.

NOTE
Loss of adhesion may be local. If this is the case, repair may also be local.

2. Chamfer the joint again as indicated in paragraph 3, Section: WELDING OF JOINT BETWEEN WHITE SAFETY STRIP AND "TARABUS" FLOOR COVERING.

3. Re-weld the joint as indicated in paragraphs 6, 7 and 8. Use your thumb to hold the filler bead end.

**WARNING**

Nozzle is hot.



4. Always add an extra inch of filler bead at the beginning and at the end of repair.
5. Perform steps indicated in paragraphs 9, 10 and 11.

16. PASSENGER SEATS

The vehicle can be equipped with different seat models and installed in a variety of seating arrangements:

1. For coaches, standard seating arrangement includes two card tables, which can be folded and removed, and pivoting seats ahead of each card table. Each pair of seats is built on a welded steel frame fastened to the side wall and on a track-mounted pedestal.
2. The "V.I.P." seat model is an optional seat. "V.I.P." seats are mounted on one row of paired seats built on a common frame on one side of the vehicle, and a row of single seats on the other side of the vehicle with an off-center aisle. Each "V.I.P." seat has its own set of armrests.

Each seat has an easily removable bottom cushion. Upholstery is clipped on the cushion frame for cleaning or replacement. To remove the fabric, simply unclip from the frame. The standard seats have three armrests. The aisle and center armrests can be folded up and down manually, while the window armrest is fixed.

16.1 ROTATING SEATS

1. Loosen completely the threaded-stud knob under the seat on the aisle side (Figure 31).

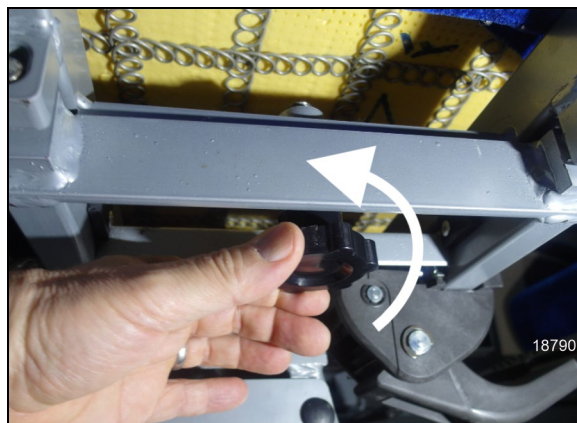

FIGURE 31: LOOSEN THE KNOB

2. Pull the seat toward the aisle to unlock the rotation (Figure 32).

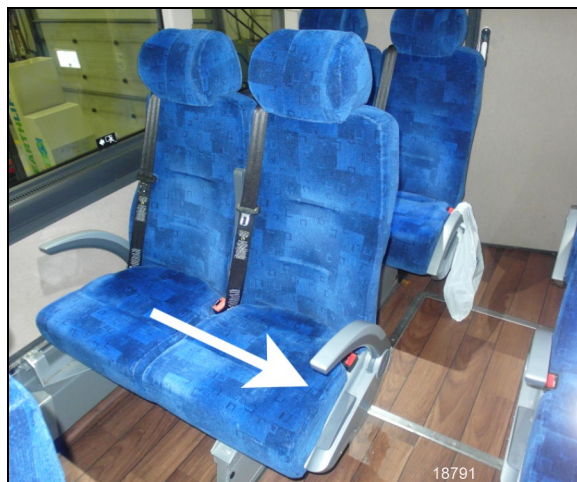

FIGURE 32: PULL TO UNLOCK THE ROTATION

3. Rotate the seats until it stops (Figure 33, A) and push back toward the window to lock rotation (Figure 33, B).



FIGURE 33: FINAL POSITION

4. Fasten the threaded-stud knob under the seat on the aisle side.

16.2 REMOVING FIXED SEATS

NOTE
Seats on one row are not interchangeable with seats of the other row.

To remove fixed seats, proceed as follows:

1. Remove 1 nut holding each seat bottom cushion from under the front part of the seat frame.
2. Lift front part of cushions and remove cushions.
3. Remove 4 finishing screws holding plastic cover between side wall and seat frame.
4. Remove 2 cap screws, nuts, and washers holding seat frame to side wall and retain the 2 holding brackets. See Figure 34 and Figure 35.

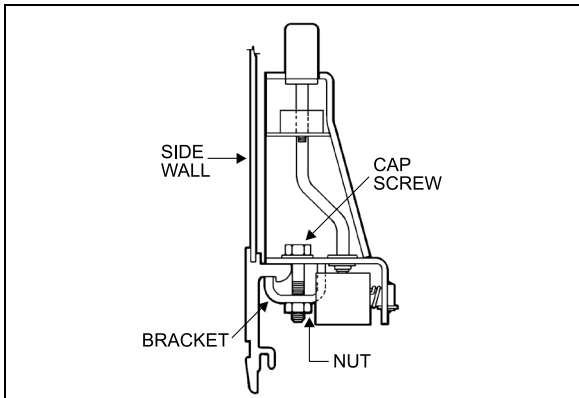

FIGURE 34: SIDE WALL MOUNTING

18106

5. Remove 2 nuts and washers holding seat frame to pedestal rods.

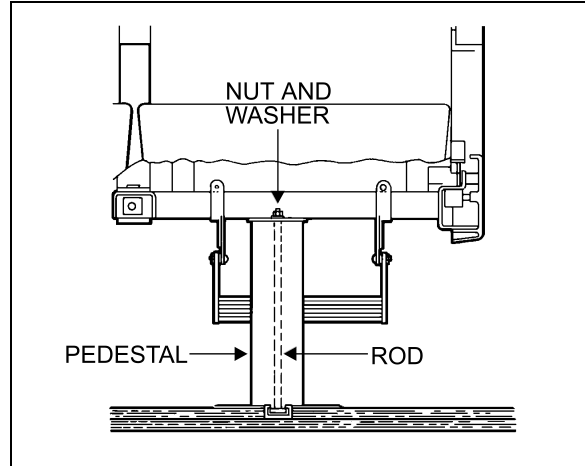

FIGURE 35: SEAT PEDESTAL ASSEMBLY

18107

NOTE

Bottom end of rod is coated with Loctite and threaded in a steel block which slides in the floor track. Removal of rod is possible if loosened from block. Otherwise, slide rod and block assembly to the front end of track after removing all seats located in front.

6. Remove seat assembly.
7. Reverse the above procedure to install seat assembly. Tighten mounting nuts.

TORQUE: 27 lb-ft (37 Nm)

NOTE

On newer vehicles, the rod consists of a carriage bolt inserted in a square plate sliding in the floor track. Removal is possible only by the front or rear end of track.

16.3 UPHOLSTERY MAINTENANCE

Coach seats are lightweight, with foam-padded backs and cushions. For both appearance and wearability, best results are obtained if upholstery is cleaned at regular intervals before dirt, dust and grit have been ground into the fabric. Seat fabric is made of 50% wool, 33% cotton, 9% nylon, and 8% acrylic.

16.3.1 Routine Cleaning

All that is required to remove the dirt is a gentle beating with the hand or the back of a brush. This will bring the dirt to the surface where it is

easily removed with a vacuum or brush in the direction of the pile which can easily be recognized by running a hand lightly over the pile. If the fabric become excessively dirty, particles of grit will cause gradual wear, reducing the life span of the fabric.

16.3.2 Dry Cleaning

If covers are to be removed for cleaning, dry cleaning is recommended since washing might cause some shrinkage, preventing the covers from being reapplied to the seats without damage. Other than spot cleaning the covers while they are in place, dry cleaning is not recommended, since the resulting fumes could be hazardous in the confines of the coach and the solvent could be detrimental to the foam padding of the seats.

16.3.3 Cleaning With Covers in Place

The most effective and economical method to clean the fabric seat covers is by washing with either an approved foam upholstery cleaner or with a mild household detergent.

Thoroughly vacuum the upholstery. Remove any spots or stains before the seats are washed to avoid a cleaning ring.

Dilute household detergent or liquid foam cleaner according to directions on the container. Pour a small quantity into a flat pan and work into a thick foam with a sponge or brush.

Apply only the foam to the fabric with a sponge or brush. Clean a small area of the fabric at a time with the foam. DO NOT SOAK. Rub vigorously.

Sponge the suds from the fabric with a clean sponge or cloth moistened with water. Rinse the sponge or cloth often and change the water when it becomes dirty.

Allow the upholstery to dry completely before the coach goes back into service. To speed up drying, excess moisture can be blown off the fabric with compressed air.



CAUTION

Oil in the air line will soil the fabric. Blow the line clear and test air discharge against a plain white piece of paper. It is also effective to press the edge of a flat hardwood stick down on the cushion and slowly draw it across the

fabric.

Even very soiled areas can be returned to their original appearance by a thorough cleaning, but a regular schedule of cleaning that keeps the upholstery reasonably clean at all times will greatly enhance the life span of upholstery.

17. COACH SIDE WINDOWS

The H3-45 has seven windows on each passenger side. On a vehicle equipped with a wheelchair lift system, only six side windows are installed on the curb side. They are made of single or double-glazed, heat absorbing AS-3 glass. Windows are mounted in painted aluminum extrusions, which hold the glass in place from the top rail of the coach. The extrusion also serves as a hinge to allow the window to swing open when needed. The single-glazed windows are made of tinted tempered safety glass, while the double-glazed windows are made of tinted tempered safety glass outside and clear tempered glass inside.

The two trapezoidal windows are also mounted on an aluminum extrusion (except for H3-45 VIP, where they're mounted with adhesives. Refer to "*Adhesive Mounted Windows*" in this section, for more information on this type of installation). The trapezoidal windows are made of fixed, double glazed, heat absorbing AS-3 tempered safety glass inside and tempered glass outside.

17.1 HYDROPHOBIC TREATMENT ON SIDE WINDOWS

The new low profile window gasket creates an airflow that is closer to the vehicle. This reduces air drag but window soiling of the side windows becomes more likely.

A specific water repelling treatment is factory applied to the driver's and entrance door windows to counter this effect and prevent window soiling.

We suggest renewing the water repelling treatment each year or more frequently depending on operating conditions.

Should you notice increased soiling on the driver's and entrance door windows after several months of operation, the water repelling treatment can be renewed by making an appointment with your nearest Prevest Service Center.

The Hydrophobic compound is specially formulated for Prevost and can only be applied by Prevost technicians in Prevost service centers.

17.2 EMERGENCY EXIT WINDOWS

Except for the window upper edge, the three other glass edges are unprotected, which causes the workers to be exceptionally careful when manipulating or installing such windows.

In addition, when it becomes necessary to lay down the unprotected edges of the glass window, never use a steel or concrete floor support. It is recommended to use a wooden support, even better, a padded surface.

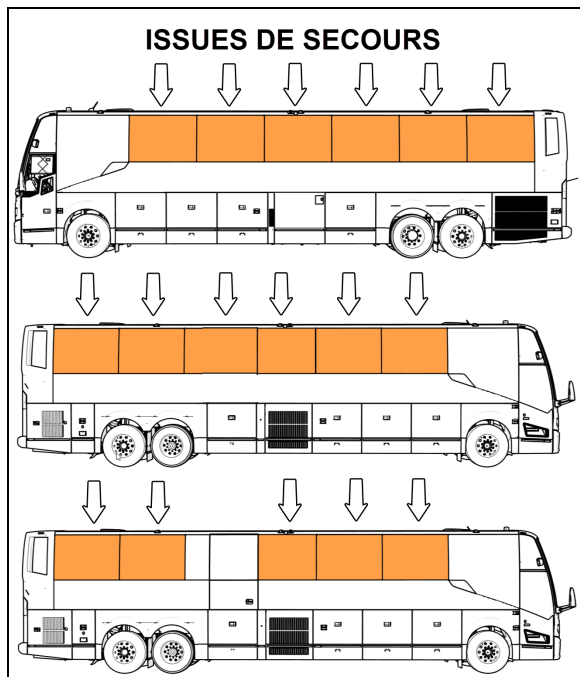

FIGURE 36: H3-45 COACH

18519

17.3 EMERGENCY EXIT RELEASE BAR

The emergency exit release bar system is generally maintenance free.

It has been designed to answer the twenty pound resistance criteria for opening the emergency window. If this handle should be replaced:

1. Remove the screws and bolts securing it to the emergency exit window;

2. To install a new release bar, reverse the procedure.

NOTE
 Check the legal twenty pound maximum resistance to be sure to comply with regulations.

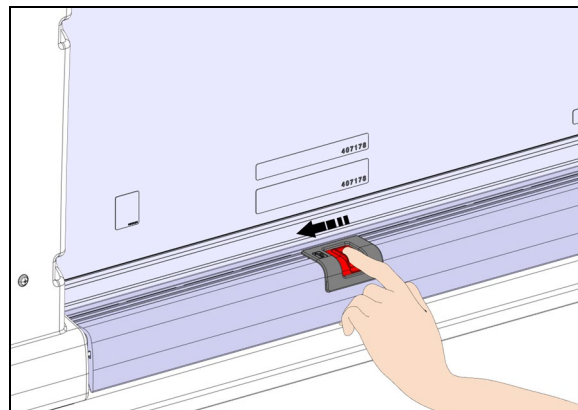

FIGURE 37: EMERGENCY EXIT WINDOW

18391

17.3.1 Emergency Exit Window Adjustment

Emergency exit windows should be checked periodically for easy opening and closing. Sliding the red button on the release bar should disengage both locks on the window simultaneously. The tension required to release the window should not exceed twenty pounds (9 kg) of force. The release bar mechanism itself has been designed such as no adjustments are necessary.

If too much effort is required to disengage the locks when pulling the release bar or if the window doesn't close tightly or rattles, check for interference by foreign objects or nearby parts into mechanism, such as the microswitch, rubber seal, wires, etc. Correct situation immediately.

NOTE
 Tangs on the lock must be in a horizontal position.

17.4 FIXED WINDOW REPLACEMENT

When it becomes necessary to replace the glass of a fixed-type window, follow this procedure:

1. Unscrew the decorative plate and the bottom window bar in order to get access to the window retaining devices.
2. Remove the window bottom retaining bolts.

3. Push the glass window out ninety degrees (90°).

**WARNING**

The window may fall out.

4. The window is free and can be unhooked.
5. Reverse procedure to install a new one.

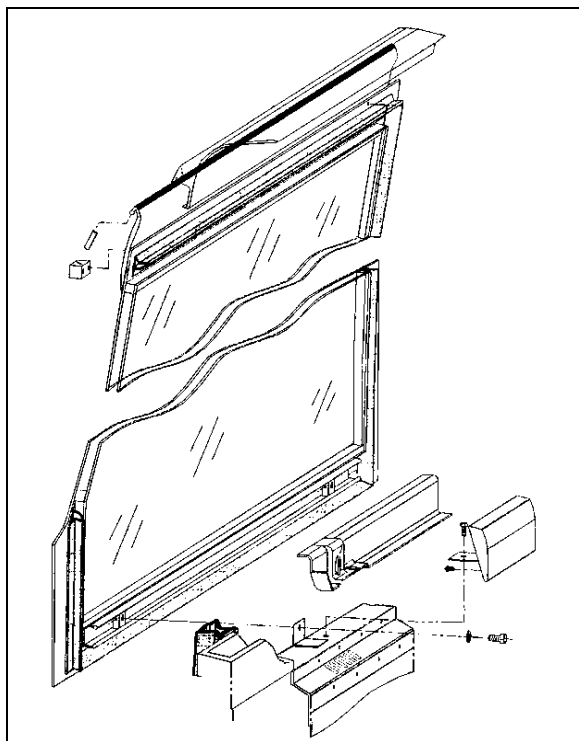

FIGURE 38: FIXED WINDOW

18434

NOTE

For all window replacement, it is extremely important to center the top side between the window dividing posts with great precision in order to be able to attach the bottom of window and the structural posts.

17.5 EMERGENCY EXIT WINDOW REPLACEMENT

1. Slide the red button to tilt up the release bar and follow the same procedure mentioned above for fixed windows.
2. Remove the stop blocks from the top exterior of the window.
3. Reverse the procedure to install a new emergency exit window.

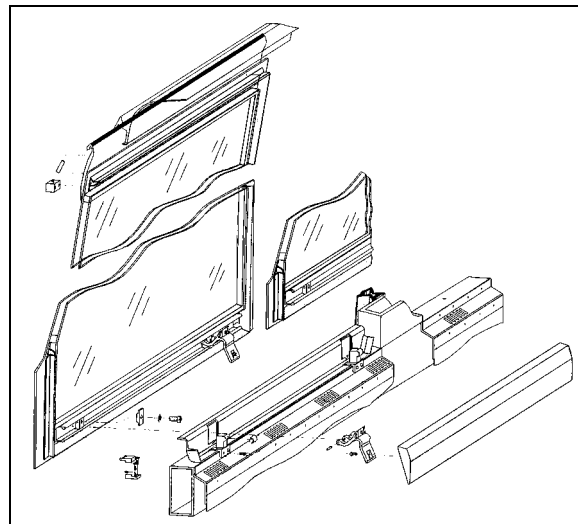

FIGURE 39: EMERGENCY WINDOW

18435

17.6 TRAPEZOIDAL WINDOW REPLACEMENT

Apply procedure for fixed window replacement described in this section but with these variations:

- The angle at which the window will detach is considerably smaller (about 45°);
- These windows are also glued to the structure at certain areas on their perimeter. Note where adhesives are used and apply gluing techniques at these areas to complete replacement of these windows.

17.7 SMALL REAR WINDOWS REPLACEMENT

These small windows are located at the vehicle's rear end, just forward of the lavatory.

Apply procedure for fixed window replacement described in this section but with these variations:

- The angle at which the window will detach is considerably smaller (about 45°);
- These windows are also glued to the structure at certain areas on their perimeter. Note where adhesives are used and apply gluing techniques at these areas to complete replacement of these windows.

Both the trapezoidal windows and the small rear window are fixed in place with adhesives. They

are not serviceable, in the event that they may need replacement.

17.8 ADHESIVE-MOUNTED WINDOWS

These windows are located in the vehicle's front and rear caps (Figure 40).

The adhesive-mounted windows are fixed, double-glazed, heat absorbing AS-2 or AS-3 glass mounted in their opening with polyurethane windshield adhesive. The double-glazed windows are tempered safety glass outside and inside.

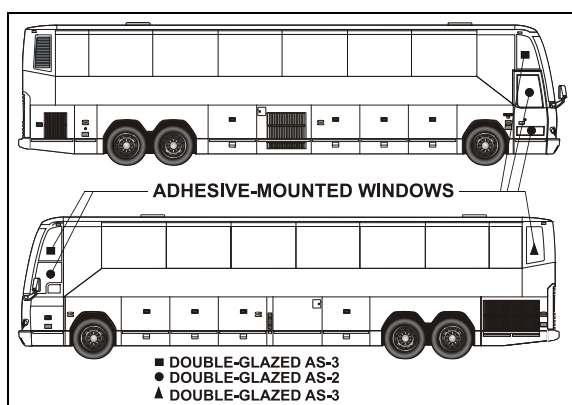

FIGURE 40: ADHESIVE-MOUNTED WINDOWS

18494

17.8.1 Glass Window Replacement

Items Needed:

- Scraper with new blade;
- Masking tape;
- Tremshield tape (Prevost #681089);
- Chix cloths (Prevost #682384);
- Isopropyl alcohol or enamel reducer or NAPA 6383 surface cleaner;
- Sika 205 cleaner;
- Sika 255 F.C. adhesive;
- Disposable vinyl gloves;



WARNING

Wear disposable vinyl gloves during this procedure. Do not smoke. Dispose of unused toxic material properly. Heed all warnings on product containers.

1. Remove old window glass and scrape off remaining material up to 1/16" to 1/8" (2 to 3 mm) thick.

NOTE

Hardened adhesive will not remove easily. A new blade works best to remove all adhesive residue using care not to damage the fiber structure.

2. Place the new window glass in the opening and center it to leave an even gap top and bottom, and from side to side.

NOTE

Use small shims to raise the glass in proper position. Shims can be cut from the tremshield tape (Figure 41).

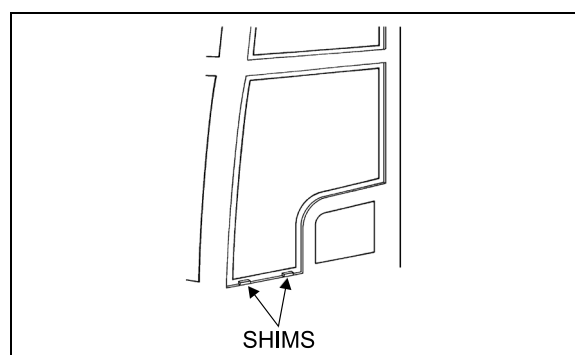

FIGURE 41: ADHESIVE-MOUNTED WINDOW

18079

3. Hold the window glass centered and have an assistant mark the inside contour of the opening on the glass with a china pencil. Remove glass and place it on a table with the pencil mark facing up.
4. Place masking tape on the inside surface of the glass to just cover the china pencil mark, leaving the outer surface exposed for the adhesive. This will make cleanup much easier. For ease of removal, do not overlap the tape at corners.

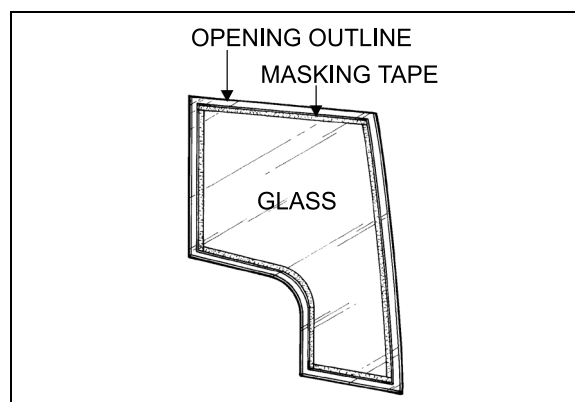

FIGURE 42: ADHESIVE-MOUNTED WINDOW

18080

- Clean all around the window opening and the window glass edge with Sikaflex 205 (shake well before applying). Let dry 5-6 minutes minimum but no more than 8 hours.

**CAUTION**

There must be absolutely no silicone on glass or channel or Sikaflex 255 FC will not stick.

- Put masking tape on the inner and outer contour of the window opening on the structure, approximately 1/16" (1,5 mm) from the edges of the contour.
- Install Tremshield tape around the sealing surface of the window opening.

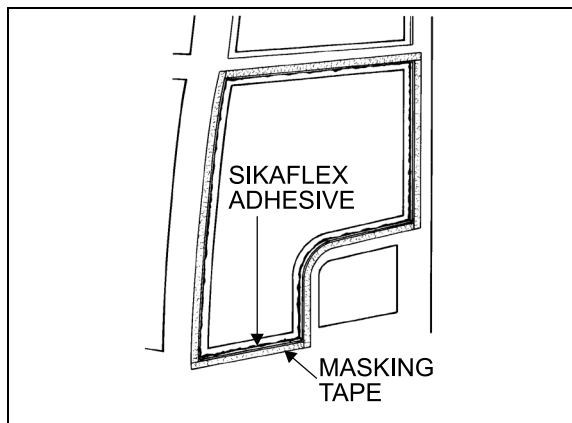

FIGURE 43: ADHESIVE-MOUNTED WINDOW

18081

- Apply a generous bead of Sikaflex-255 FC polyurethane adhesive on the sealing surface around the window opening from outside the vehicle.

NOTE

To ease applying of Sikaflex 255 FC, it may be heated to 86° F (30°C).

NOTE

Bead should touch the side surface of the window opening.

- Place shims correctly, and position window glass in the opening. Press firmly and evenly. Excess adhesive should flow out from behind glass.

NOTE

Add adhesive in areas where overflow is minimal or if air bubbles are present.

- Smooth the adhesive joint using your finger (wear vinyl gloves). Remove excess material around both sides of the window as soon as possible before adhesive dries.

NOTE

Remove most of the adhesive from the scraper or trowel with a rag, and then dip tool in solvent after each use for cleaning.

**CAUTION**

Never use solvents to clean excess adhesive.

- Remove masking tape at once, clamp window glass suitably and let dry overnight or at least 8 hours.
- Spraying pure water on the joint will accelerate the drying process.

18. ELECTRIC AWNING WINDOW

The electric awning windows are connected directly on the batteries 24 V DC terminal block. As a result, they can be operated regardless of the state open or close of the master switch. However, the circuit is protected with fuse F41 (10A) located in the front service compartment.

18.1 OPERATION

Opening sequence: switch is set to the OPEN position. Window latch solenoid SOL1-A and SOL1-B are turned on along with M1 window motor. Once the latch is open, proximity switch PROX1 is de-activated, turning sol1-A and SOL1-B off.

Closing sequence: switch is set to the CLOSE position, turning on relay R1 which turns on M1 in reverse polarity, closing the window. Once the window is closed, PROX1 is activated, turning on SOL1-A and SOL1-B in reverse polarity latching the window closed.

18.2 WINDOW REMOVAL

Replacement awning window does not include a new motor. If in working order, transfer the motor of the replaced window to the replacement window. If not, the motor can be bought separately. When replacing the window, keep the components in working order as spare parts.

1. Push the vertical latch handle downwards to release the track and then open the window using the horizontal latch handle.
2. Take out the screw at the lower end of the track to let free the swiveling arm roller.
3. Unplug connector C7 & C9. Dismount the gas spring from the window.
4. Loosen the set screws #5 (Figure 45) (rotate the arm to get to the second set screw) and disengage the swiveling arm from the motor shaft extension.

5. Push the glass window out ninety degrees (90°).



WARNING

The window may fall out.

6. The window is free and can be unhooked.
7. Reverse procedure to install a new one.

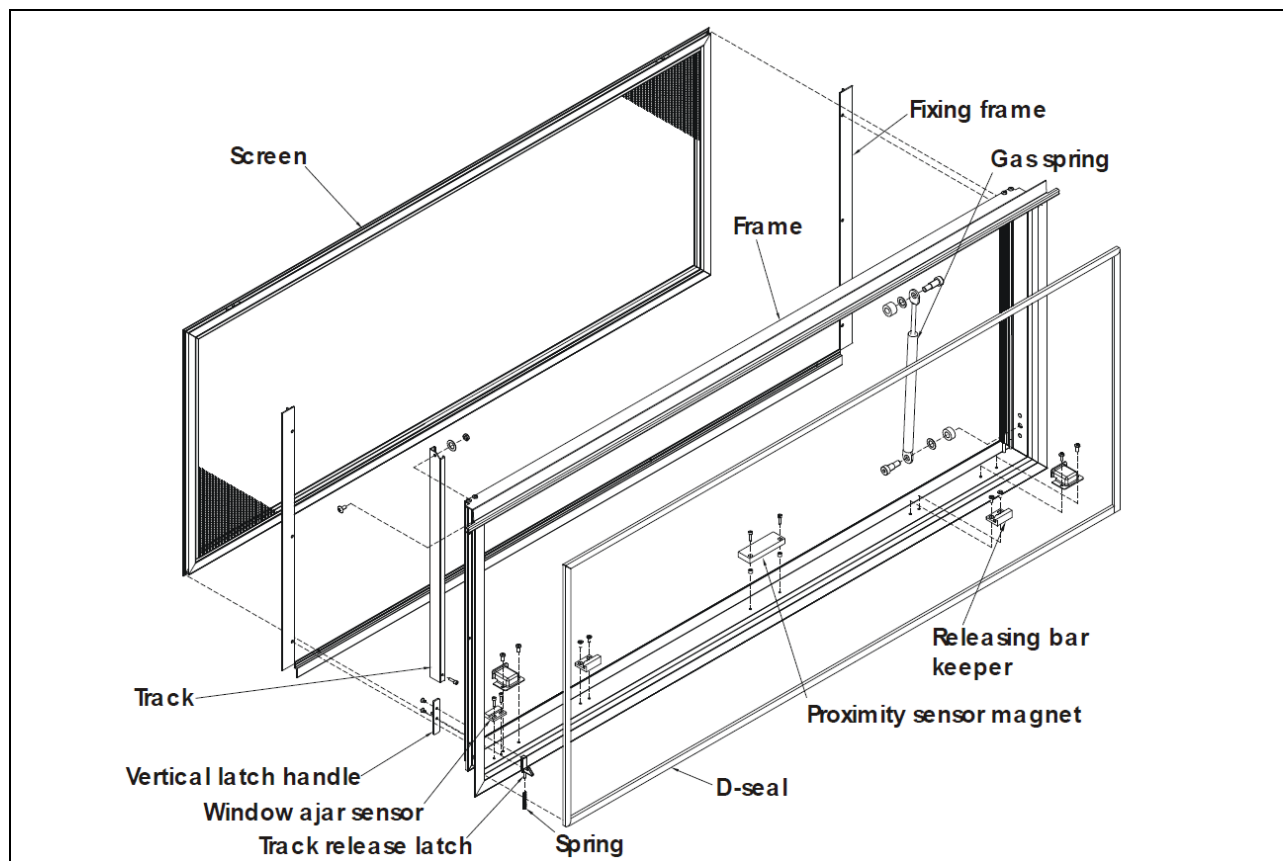

FIGURE 44: ELECTRIC AWNING WINDOW EXPLODED VIEW (FRAME)

18586

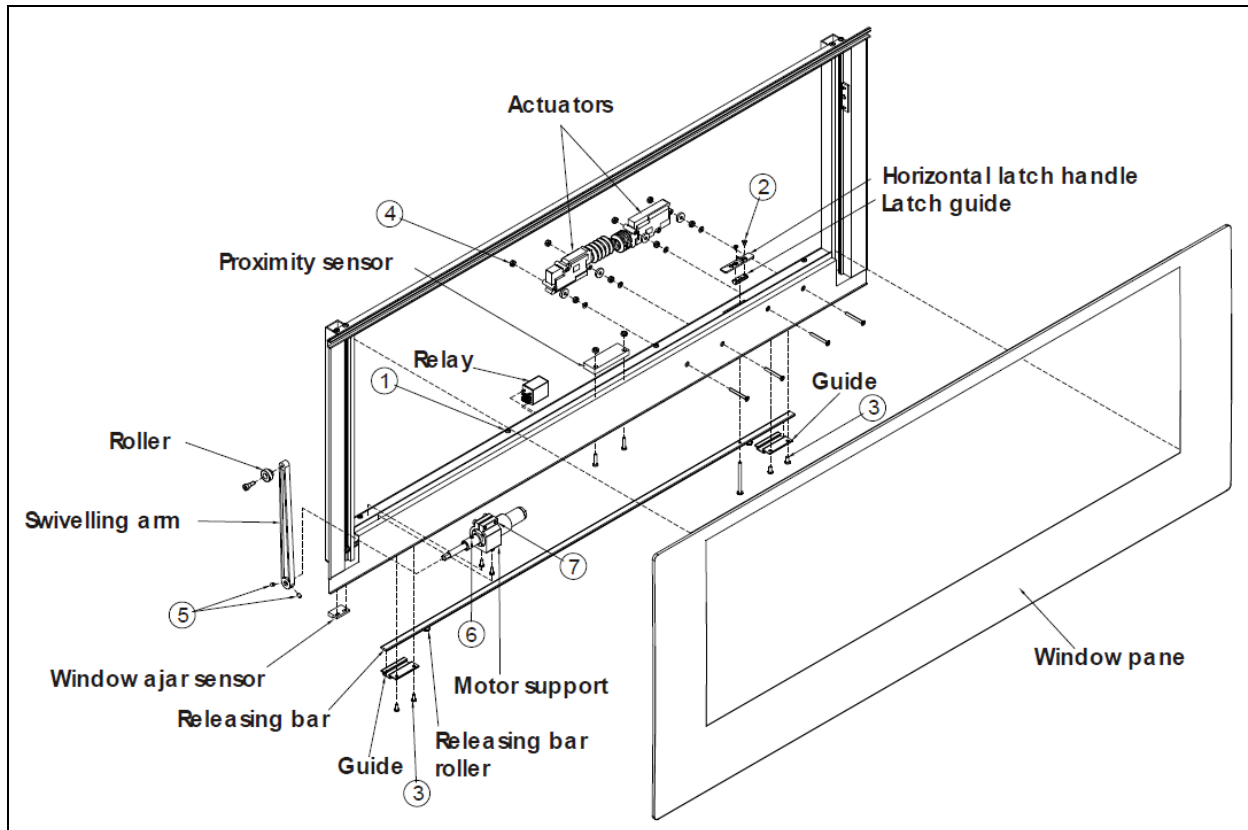

FIGURE 45: ELECTRIC AWNING WINDOW EXPLODED VIEW (SASH)

18583

18.3 ACTUATOR REPLACEMENT

1. Push the vertical latch handle downwards to release the track and then unlatch the window using the horizontal latch handle.
2. Remove actuator access cover by taking out screws #1 (8x).
3. Take out screws #2 (2x) and remove horizontal latch handle and guide.
4. Take out the guide screws #3 (4x) and remove releasing bar.
5. Unplug connector C3 or C4 from problem actuator, unscrew nuts #4 (2x) and remove the actuator.
6. Reverse operations for reinstallation.

2. Take out the screw at the lower end of the track to let free the swiveling arm roller.
3. Remove actuator access cover by taking out screws #1 (8x).
4. Loosen the set screws #5 (rotate the arm to get to the second set screw) and disengage the swiveling arm from the motor shaft extension.
5. Unplug motor connector C2 and dismount motor and support assembly.
6. The shaft extension is glued to the motor shaft. It has to be heated to break the binding to permit removal. Loosen set screw #6 and remove the shaft extension. Also loosen screw #7 and remove motor from the support.
7. Reverse operations for reinstallation.

18.4 MOTOR REPLACEMENT

1. Push the vertical latch handle downwards to release the track and then unlatch the window using the horizontal latch handle

ELECTRIC AWNING WINDOW – CONVERTER CHECKLIST	
<p>Check the electrical circuit & proximity sensor</p>	<p>A: The latching system will not operate without power.</p> <p>Is there electrical power to the latching circuit? The horizontal latch handle, on the sill sash will be seen to move if there is power on this circuit, or it can be checked with an electrical tester. If there is no power to this circuit when the window is closed and either rocker switch are switched "ON", there is a problem with the electrical system.</p> <p>B: The Proximity Sensor on the sash may not be switching power to the latching circuit if the magnet is not getting close enough to the switch OR the Proximity Sensor may be broken (or stuck in one position).</p> <p>Is the proximity sensor switching when the window is closed?</p>
<p>Check the release force required to operate the horizontal latch handle</p>	<p>A: If the pull force required to move the latch is more than 20lbs the window will not latch properly. Average pull force during testing by manufacturer is 12lbs -15lbs.</p> <p>What is the force required to release the handle? Check using a force gauge (same test done by manufacturer).</p>
<p>Check Installation</p>	<p>A: If the window is too tightly installed OR if the sequence for tightening the clamping frame screws is incorrect the window may not close properly.</p> <p>Was the window installed correctly?</p> <p>Was the correct sequence (see below) used when tightening the clamping frame screws?</p> <div style="text-align: center;"> </div> <p>B: Removing the shipping blocks before the window is installed can create major problems.</p> <p>Were the shipping blocks in place during installation?</p> <p>C: Failure to remove the shipping blocks after installation can create interference between sash and frame.</p> <p>Have the shipping blocks been removed after installation?</p> <p>D: The window is misaligned or not installed squarely.</p> <p>Is there interference with any coach parts?</p> <p>Is there proper clearance between the bottom of the outer glass and the belt-line trim / seal?</p>
<p>Check for missing parts or misaligned parts</p>	<p>A: The frame and sash are misaligned.</p> <p>Is there any interference between the sash and frame?</p> <p>Is there clearance between the sash and the rocker switch covers?</p> <p>B: Releasing bar guides are missing.</p> <p>Check that the releasing bar guides are installed. There should be 4 installed on H windows, and 3 installed on XL2 windows.</p>

19. ELECTRIC SLIDING WINDOW

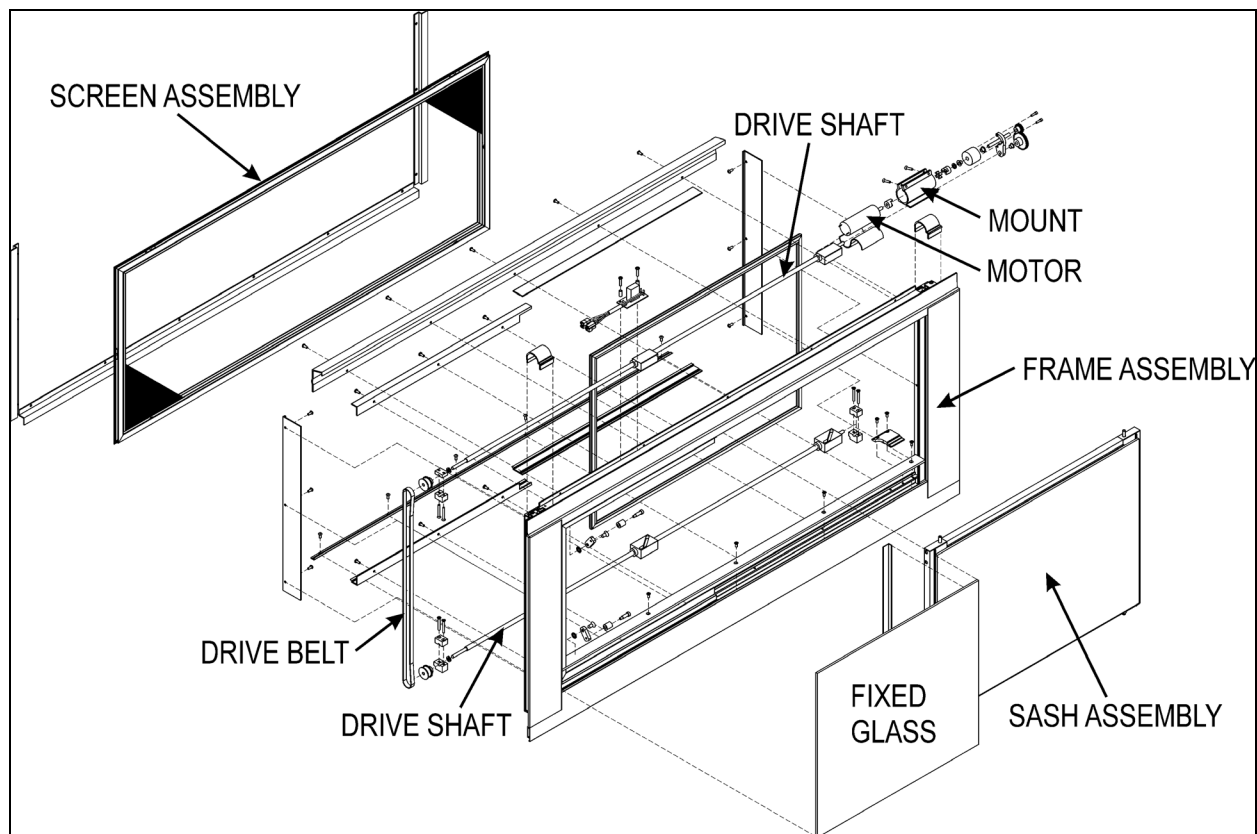

FIGURE 46: ELECTRIC SLIDING WINDOW EXPLODED VIEW

Sash Removal

1. Remove the Screen Assembly
2. Pull down on both release latches simultaneously and rotate the sash inwards approximately 10 degrees.(Figure 47)



FIGURE 47: REMOVING THE SASH

3. Lift the sash up and out to disengage the bottom of the sash from the window frame. (Figure 48)



FIGURE 48: DISENGAGING THE BOTTOM OF THE SASH

Installation

1. Align the leading edge of the slot on the lower cam follower block with the sash stop. Use the power toggle switch to obtain the correct alignment. (Figure 49)

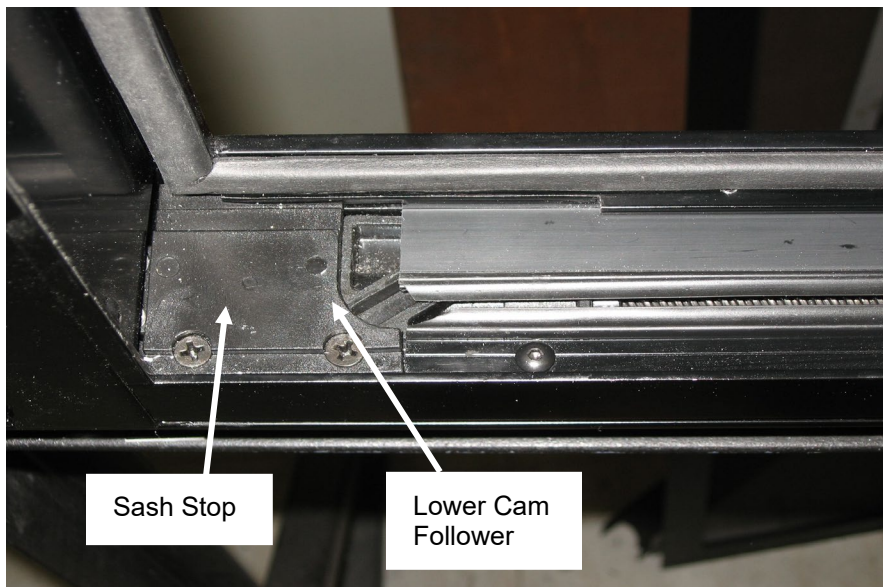

FIGURE 49: PROPER ALIGNMENT

2. Position the left hand lower corner of the sash over the front cam follower block (Figure 50)



FIGURE 50: POSITIONING THE LOWER LEFT CORNER OF THE SASH

3. Engage the sash pin with the leading edge of the slot of the cam follower block. Do the same at the rear of the sash.
4. Pull down on the release latches and rotate the sash inwards until it is parallel with the window frame.
5. Release the latches to engage the latch pins with the upper cam follower blocks.
6. Confirm that both latches are in the closed (latched) position. The upper edge of the latch opening must be aligned with upper edge of the sash opening (Figure 51)

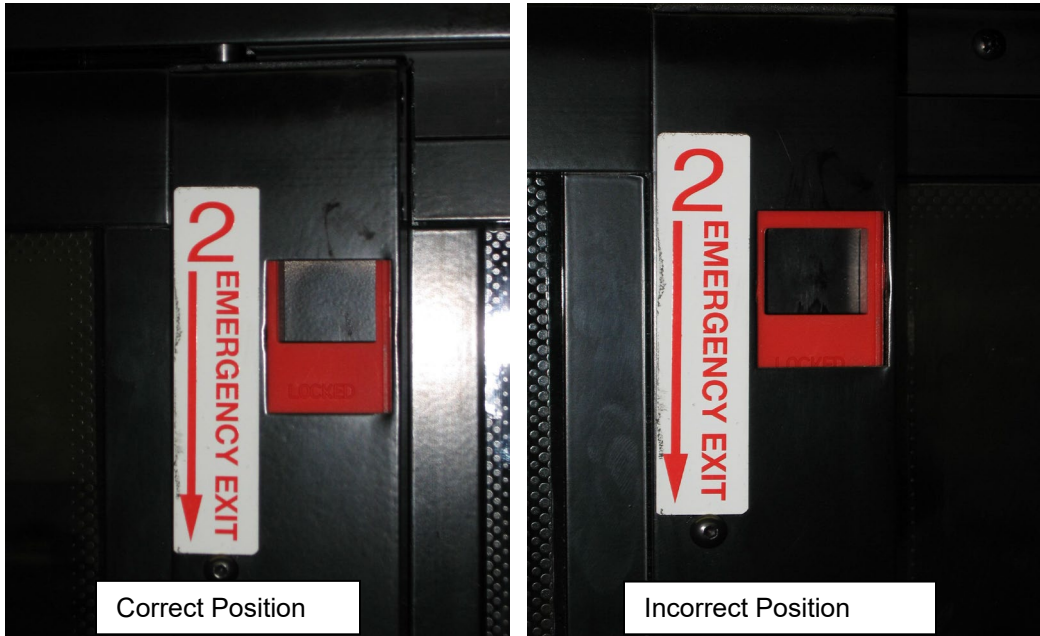

FIGURE 51: RELEASE LATCH PROPER POSITION

- 7. * Failure to confirm this step may lead to the sash becoming disengaged with the frame and could result in personal injury.
- 8. Operate the window to confirm that it opens and closes properly.

Install the screen assembly.

20. WINDSHIELD

The windshield is single-glazed AS-1 laminated safety glass. Each windshield is secured to a flange around the front structure opening by a one-piece black rubber extruded gasket

A low profile gasket with a single locking strip is now used on our vehicles.

Proper installation of the windshield ensures watertightness. Since glass varies in fit depending on the supplier, we recommend installing a replacement windshield obtained from Prevost Parts to ensure proper fit.

NOTE
 For more information on windshield removal or installation, a webinar is available from Prevost.

20.1 REMOVAL

WARNING

Removal and installation must be performed by more than one person. Wear protective gloves when handling the windshield.

- 1. Remove the wiper arms of the affected windshield.
- 2. To ease damaged windshield removal, remove the rubber locking strips from the rubber extrusion.

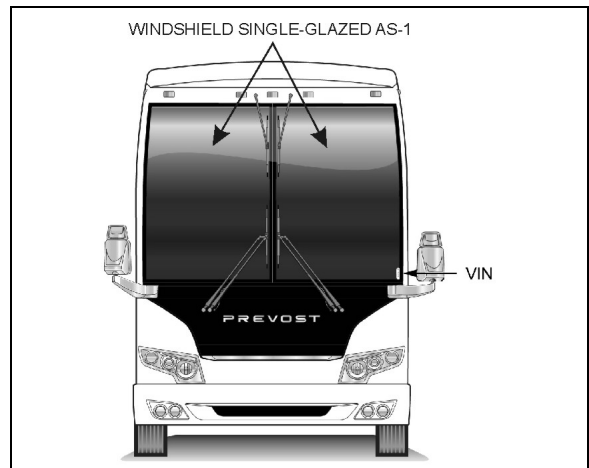

FIGURE 52: WINDSHIELD

18495A

- From inside of vehicle, push against the top L.H. side corner of windshield for the removal of a R.H. side windshield. If the L.H. side windshield had to be removed, you would have to push against the top R.H. side corner.

NOTE

We are referring to the L.H. and R.H. side as viewed from the inside of the vehicle.

- At the same time, another person gradually lifts the rubber lip from the vehicle exterior using a plastic spatula from top to bottom.
- Remove the entire damaged windshield and broken glass if applicable.
- Clean the rubber extrusion channel with Standox anti-silicone. Refer to heading "Windshield Installation" in this section for instructions on how to reinstall windshield.

NOTE

If the rubber extrusion is damaged, remove and discard it, then clean the windshield opening with Standox anti-silicone. Refer to heading "Installation of Rubber Extrusion" in this section for complete instructions.

20.2 WINDSHIELD INSTALLATION

This procedure is provided as a general guideline to install a new windshield with a new gasket on a **clean structure**. The method may vary depending on material aging and condition.

**WARNING**

Removal and installation must be performed by more than one person. Wear protective gloves when handling the windshield.

**CAUTION**

The rubber extrusion securing the windshield in the opening fits correctly in only one position. Find the correct position of the rubber extrusion now and make reference marks with a china marker to avoid searching for the correct position later in the procedure.

20.2.1 Preparation

- Clean the area shown on the image below with Standox anti-silicone and let dry.

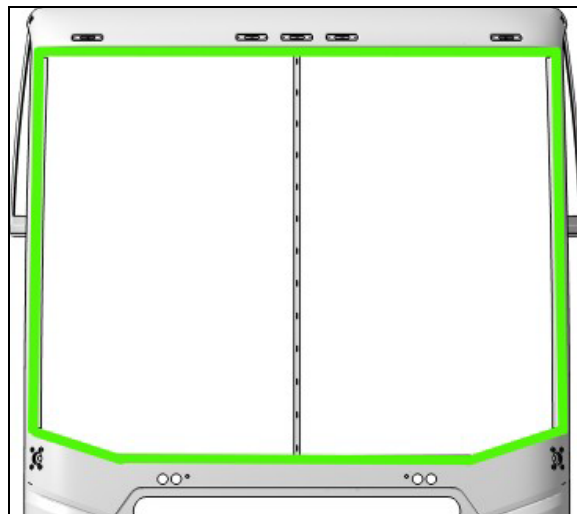

FIGURE 53

- Clean the rubber extrusion groove (Figure 54) that will be in contact with the front fiber panel on the 3 sides and on a length of 8" at the bottom, both sides (Figure 55).

A white powder may remain in the groove of new rubber extrusion. Do not leave the white powder in the groove.

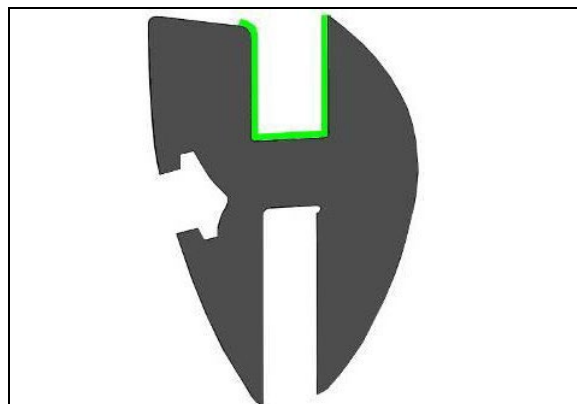

FIGURE 54

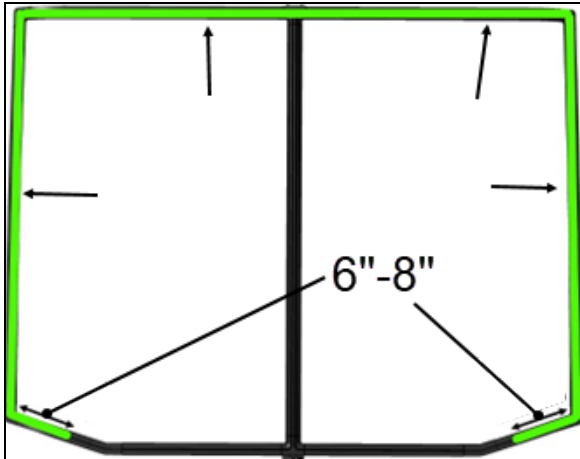

FIGURE 55

3. Apply a 1/8" (3 mm) bead of black Simson 70-03 sealant at the bottom of the groove (Figure 56) that will be in contact with the front fiber panel on the 3 sides and on a length of 8" at the bottom, both sides (Figure 55).

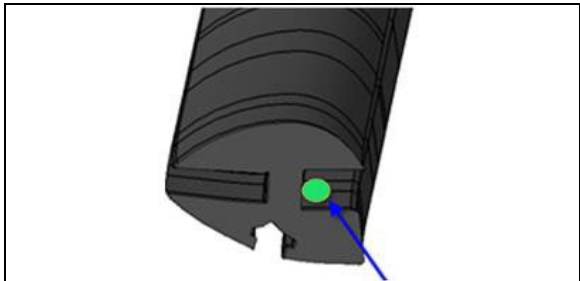

FIGURE 56: BEAD OF BLACK SIMSON 70-03 SEALANT

4. Apply a 1/8" (3 mm) bead of black Simson 70-03 sealant on the fiber panel as shown (Figure 57).

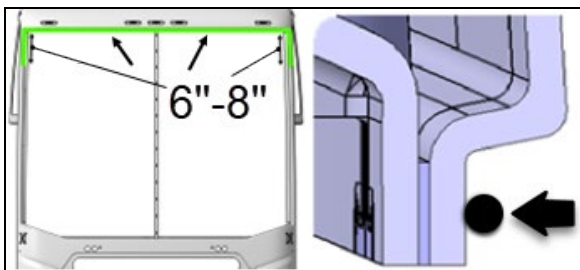

FIGURE 57: BEAD OF BLACK SIMSON 70-03 SEALANT

5. Spread the sealant on the fiber surface as shown (Figure 58).

Thickness 3/64" - 5/64" (1 mm - 2 mm)

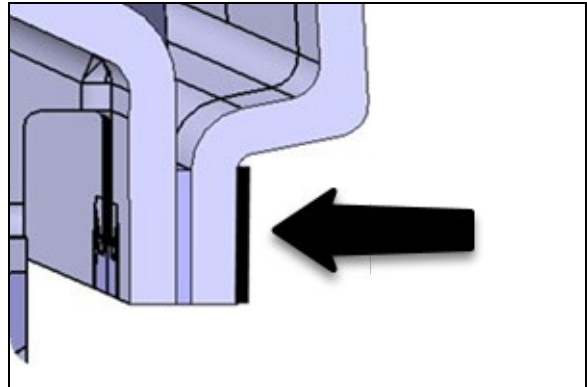

FIGURE 58

20.2.2 Installation of rubber extrusion

1. Begin installation of the rubber extrusion at the upper center (item 1, Figure 59). Make sure it is centered in relation to the vertical member.

Do not use soapy water

2. Insert the rubber extrusion at the location identified #2 (Figure 59).

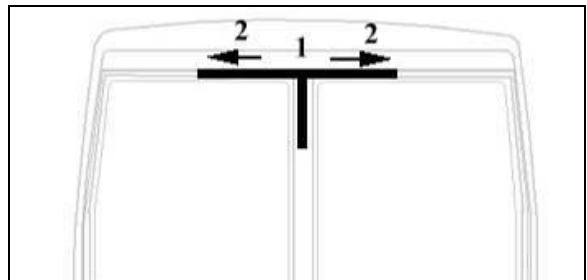

FIGURE 59

3. Bend the corners and insert at location identified #3 (Figure 60).

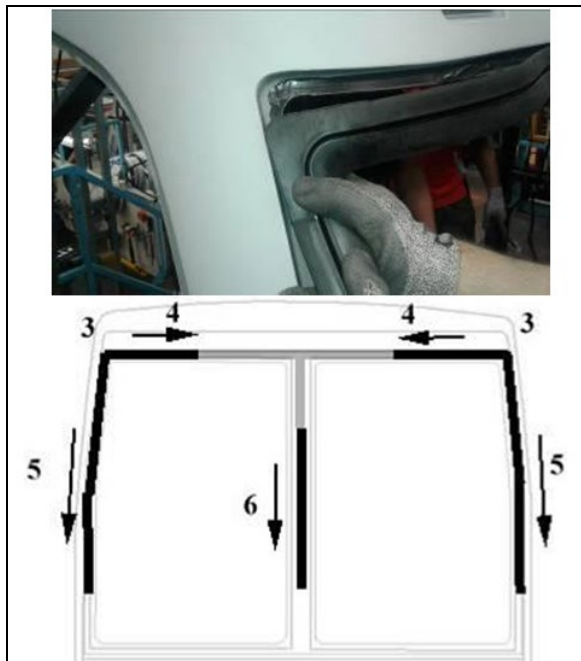

FIGURE 60

4. Insert the rubber extrusion at the location identified #4 (Figure 60).
5. Insert the rubber extrusion at the location identified #5 (Figure 60).
6. Insert the rubber extrusion at the location identified #6 (Figure 60). Use of soapy water is allowed for this section step.
7. Apply soapy water. Insert the rubber extrusion at the location identified #7 (Figure 61). Make sure it is centered in relation to the vertical member.
8. Insert the rubber extrusion at the location identified #8 (Figure 61).

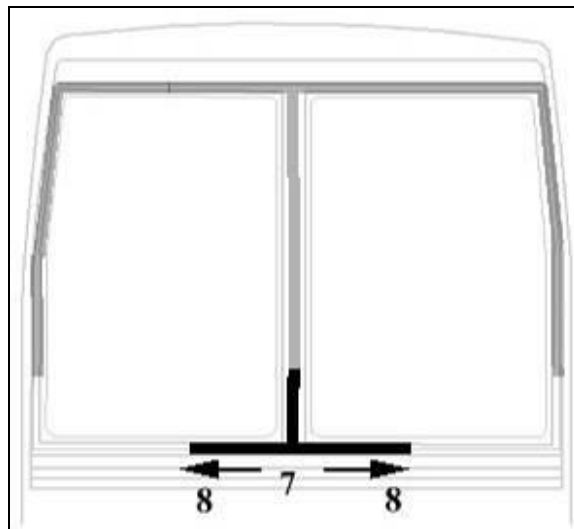

FIGURE 61

9. Bend the corners and insert at location identified #9 (Figure 62).

Do not use soapy water

10. Insert the rubber extrusion at the location identified #10 (Figure 62).
11. Insert the rubber extrusion at the location identified #11 (Figure 62).

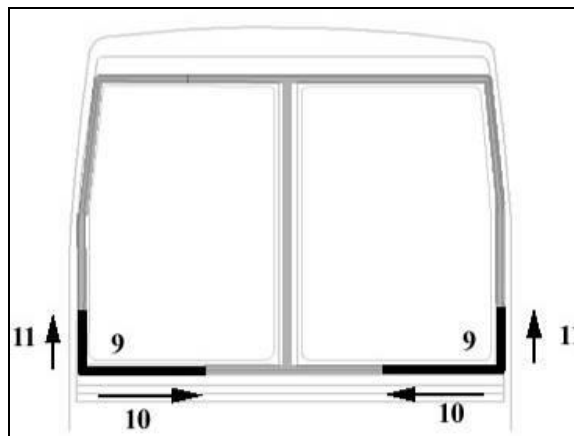

FIGURE 62

12. Apply masking tape (Figure 63 & Figure 64).
13. Wait for Simson adhesive to bond



FIGURE 63: MASKING TAPE APPLICATION

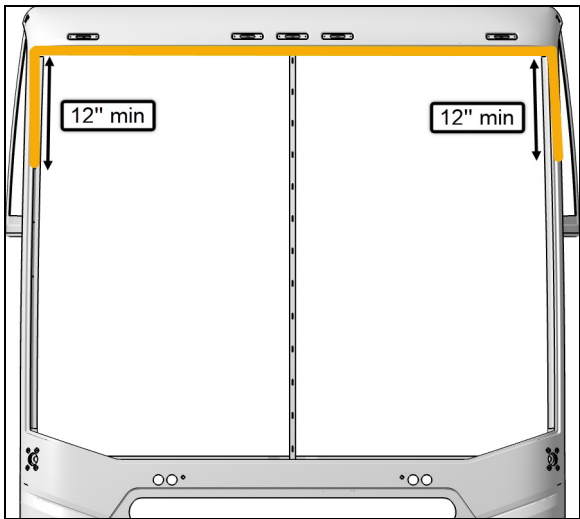

FIGURE 64: MASKING TAPE APPLICATION

20.2.3 Windshield insertion

1. Spray the groove at the bottom of the rubber extrusion with soapy water to ease windshield insertion (Figure 65).

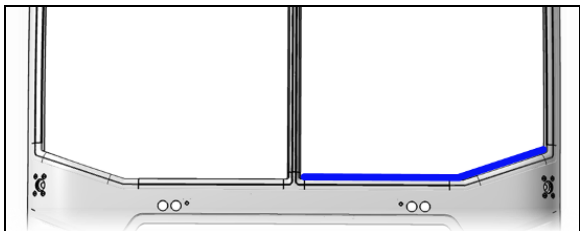

FIGURE 65

2. Slide windshield into rubber extrusion groove starting at the bottom Figure 66. Using a plastic spatula, move the rubber extrusion lip aside to gradually insert the windshield into the groove.

NOTE
 Spray soapy water on a regular basis to ease

windshield insertion.

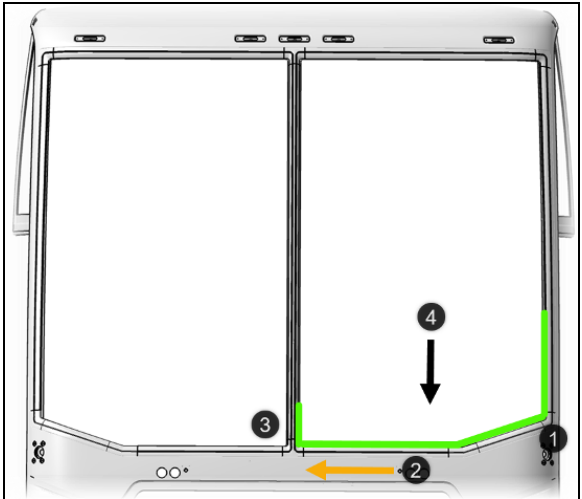

FIGURE 66

NOTE
 Make sure windshield bottom edge is well inserted into the rubber extrusion groove before proceeding with the sides.

4. Then, working from both sides of windshield bottom to top, gradually move the rubber extrusion lip aside to insert the windshield into the groove. Use also soapy water on the inside of vehicle to insert the windshield into the rubber gasket groove.
5. Check from the inside, that the gasket has remained in place.
6. Insert the top curved corner then finish with the top of windshield.

20.2.4 Locking strip insertion

NOTE
 Locking strips retract with time. Install ends of locking strips as tight as possible in the V-channel.

1. Spray locking strip and rubber extrusion groove generously with soapy water.
2. Insert the locking strip into insertion tool 680755.



FIGURE 67: LOCKING STRIP INSERTION TOOL 680755

3. Insert the strip into the rubber extrusion groove. Start in the middle, at the upper end of the windshield (Figure 69).

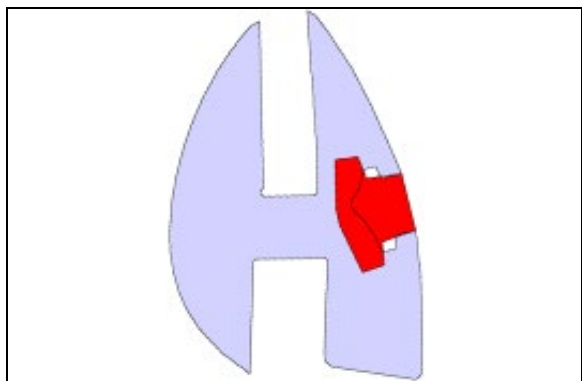

FIGURE 68: WINDSHIELD INSTALLATION SIDE VIEW

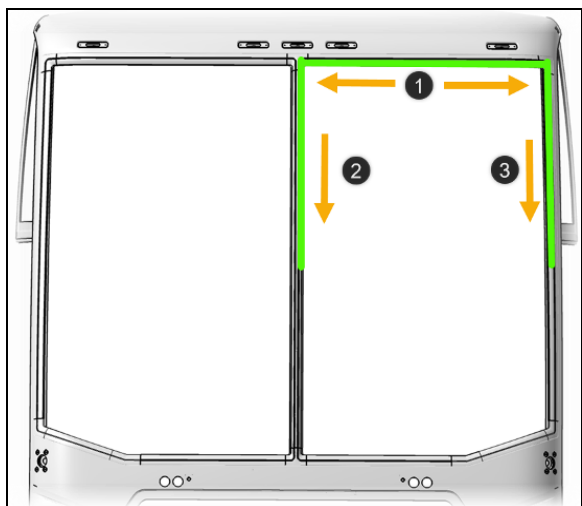

FIGURE 69



FIGURE 70

4. Carry on with the insertion of the strip into the rubber extrusion groove (Figure 71).

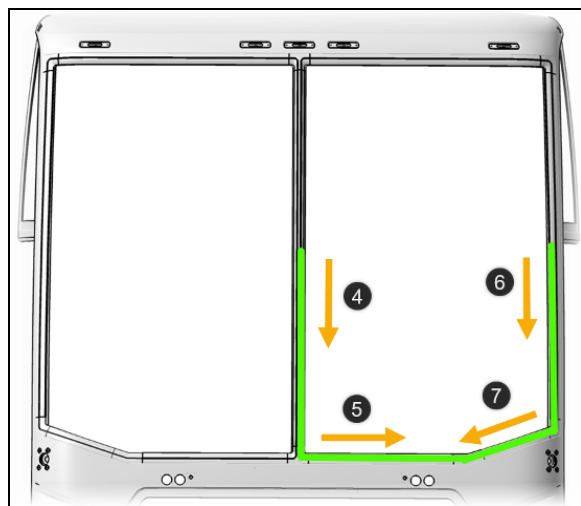

FIGURE 71

5. When strip insertion is almost complete, cut end at a 45° angle leaving 1/4" of excess length to prevent contraction over time then insert strip into groove.

21. BODY PANELS AND DOORS

Each of the doors should be checked for proper operation. This includes latching. Also, inspect each of the doors for damage, missing, or loose parts. Repair or replace those parts as needed.

Unless otherwise noted, body panels and doors should be aligned and centered with surrounding panels. In general, a gap of 1/4 inch (6 mm) is desirable between panels. Refer to Figure 72 for specified gaps.

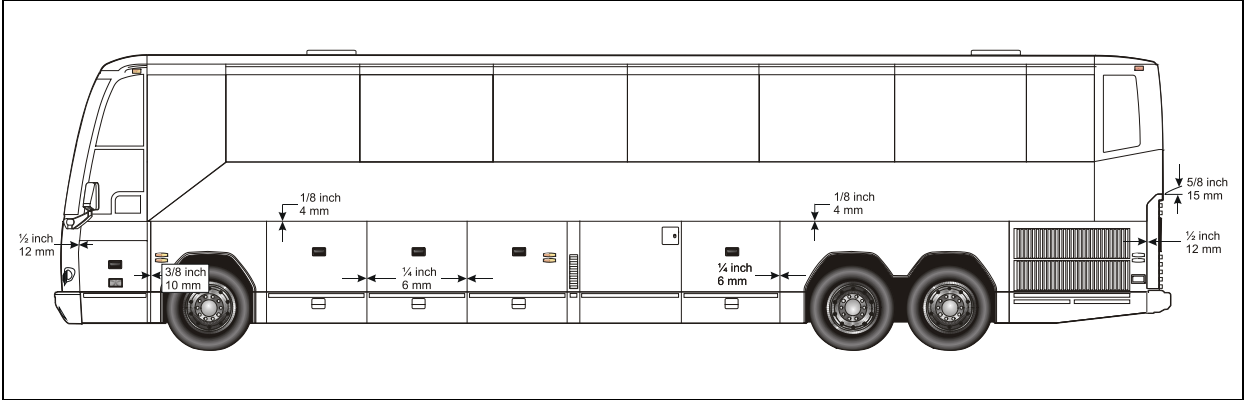

FIGURE 72: BODY PANEL SPACING

18496

22. WHEELCHAIR LIFT ACCESS DOOR

22.1 INSTALLATION



CAUTION

Install the sliding door onto a suitable lifting device that will allow proper lifting and positioning.

1. Lift and move the sliding door near the opening.
2. Push the door into the opening making sure the positioning lugs are properly inserted into their housing then pivot the main hinge and secure the door using 4 bolts. Do not fully tighten the bolts yet.
3. Remove the lifting device from the sliding door.

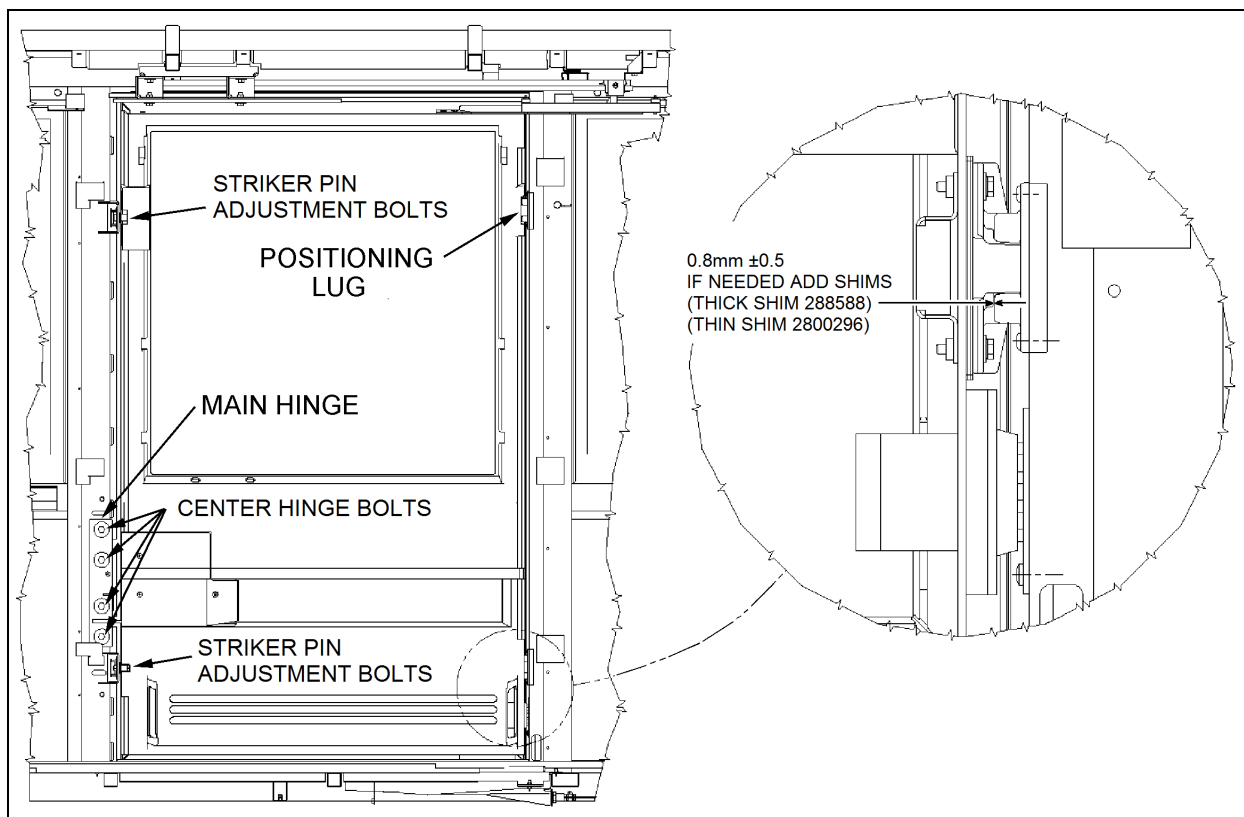

FIGURE 73: WCL SLIDING DOOR INSTALLATION

18739

22.2 ADJUSTMENT

1. Adjust sliding door height with reference to the side panels and windows.
2. Slide the top rail into the upper arm then bolt the rail to the structure. Do not fully tighten (Refer to Figure 74).

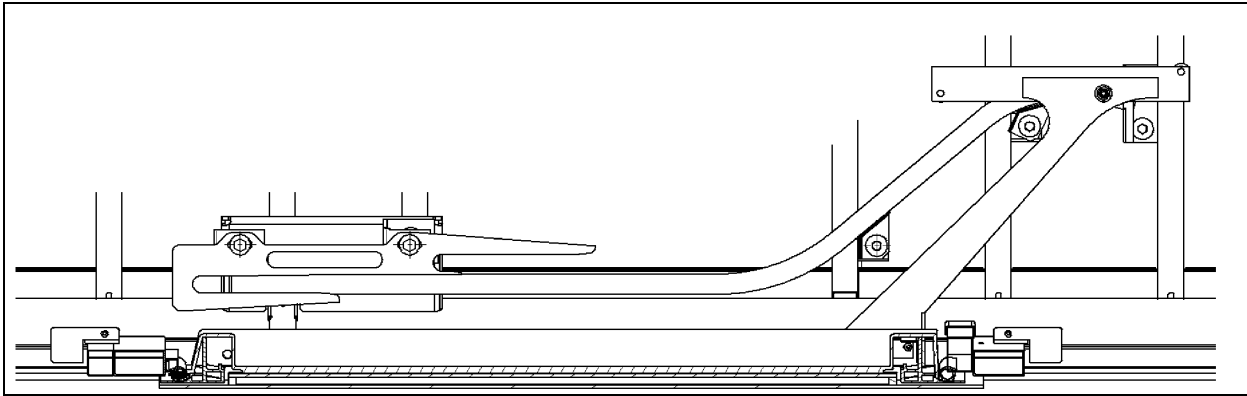

FIGURE 74: WCL UPPER ARM AND RAIL

3. Pull the door in or push from the outside to adjust the door with reference to the vehicle outside surface.
4. - Unfasten the upper arm bolt located on the door side.
 - Position the top rail at 3mm from the ceiling bracket.
 - Force the upper arm down then tighten the upper arm fixing bolt.
 - Pull the upper rail towards the inside in order to remove the play between the roller and the upper rail then tighten the rail fixing bolt at the back.
 - Push the lower rail towards the outside in order to remove the play between the roller and the lower rail then tighten the rail fixing bolt at the back.

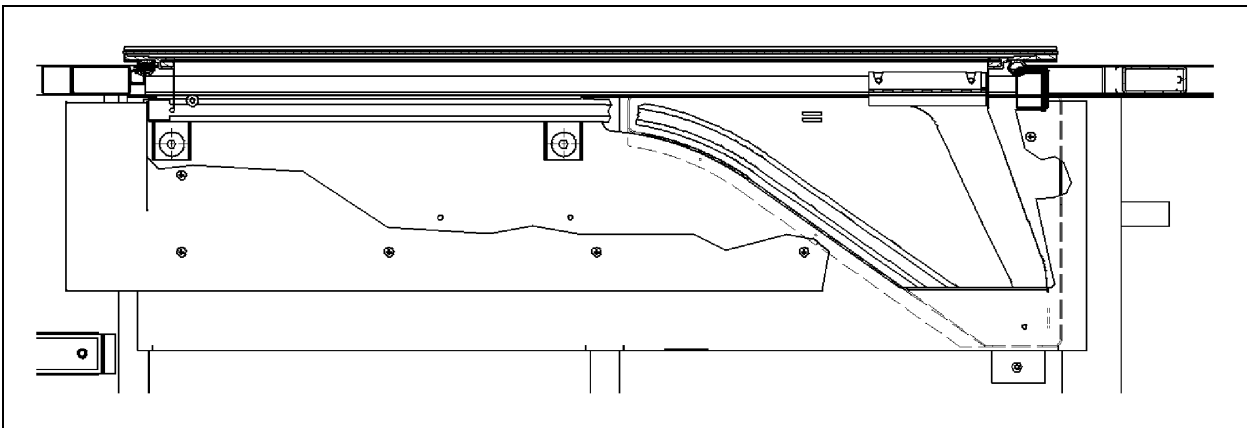

FIGURE 75: WCL LOWER RAIL INSTALLATION

5. Adjust the gap between the positioning lugs and their housing, required gap: 0.5 – 1.5mm. Add shims underneath the lugs to get the proper adjustment.
6. Take away the plays from the upper arm assembly by lifting the main hinge using a crowbar. Tighten the main hinge bolts

TORQUE: 31-38 lb-ft (42-52 Nm)

NOTE

Do not exert too much force to lift the door.

7. Open WCL sliding door completely.
8. - Pull the upper rail towards the inside in order to remove the play between the roller and rail then bolt the rail at front and center. Add some shims if necessary between the rail and the structure before tightening the bolts.

- Push the lower rail towards the outside of the vehicle in order to remove the play between the roller and rail then bolt the rail at front and center. Make sure the rollers stay in contact with the support when starting to close the door.
9. Adjust the distance between the bottom of the guide and the roller when the door is completely open. Required distance: 2 – 3mm. Make sure the roller stay in contact with the guide.
 10. Install and adjust striker pins.

TORQUE: 54-66 lb-ft (73-89 Nm)

<i>NOTE</i>

<i>Make sure that a 2mm gap exists between the door structure and the striker.</i>
--

11. Adjust latches releasing, the two latches must open simultaneously.

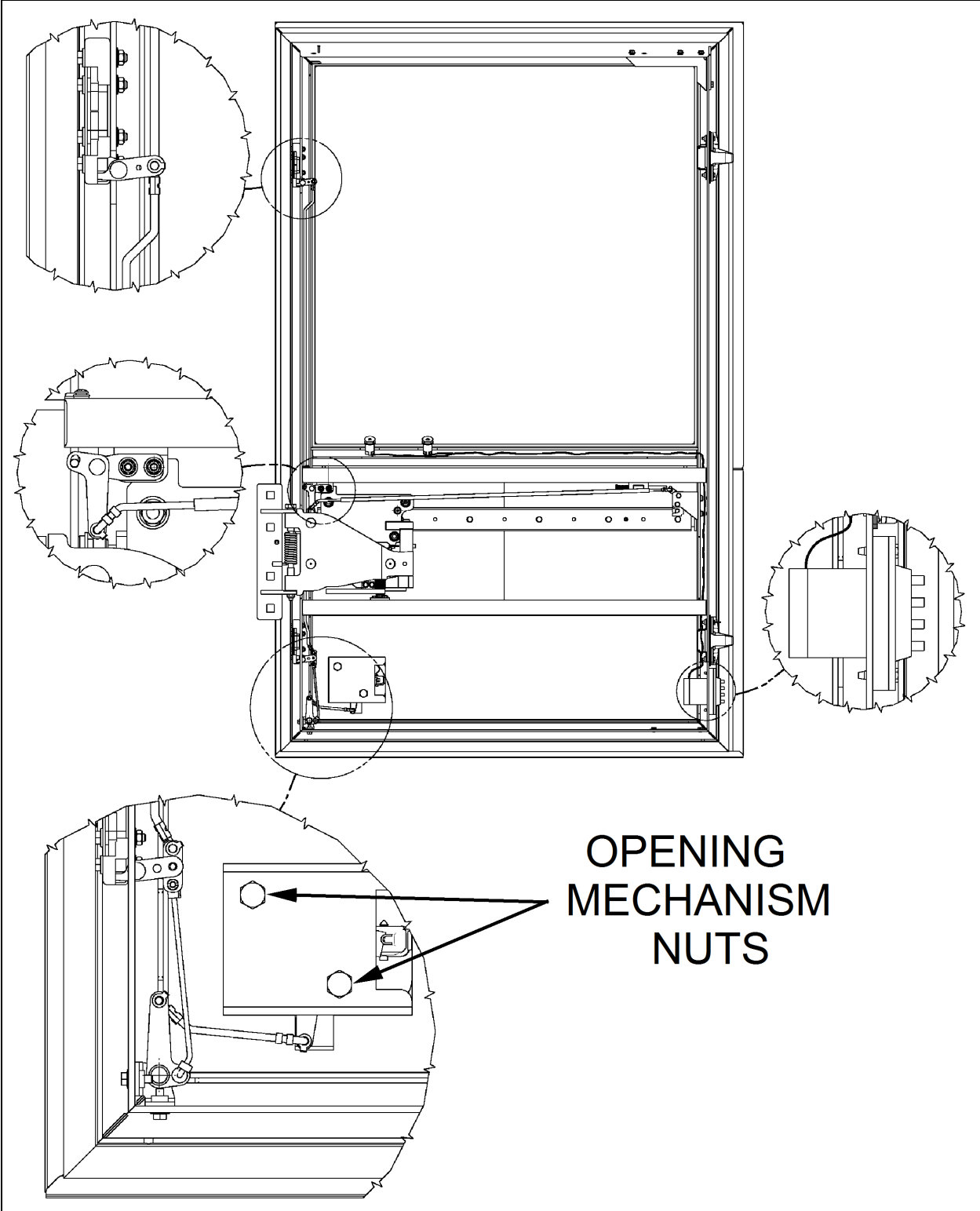

FIGURE 76: WCL SLIDING DOOR OPENING MECHANISM

18740

23. BAGGAGE COMPARTMENT DOORS

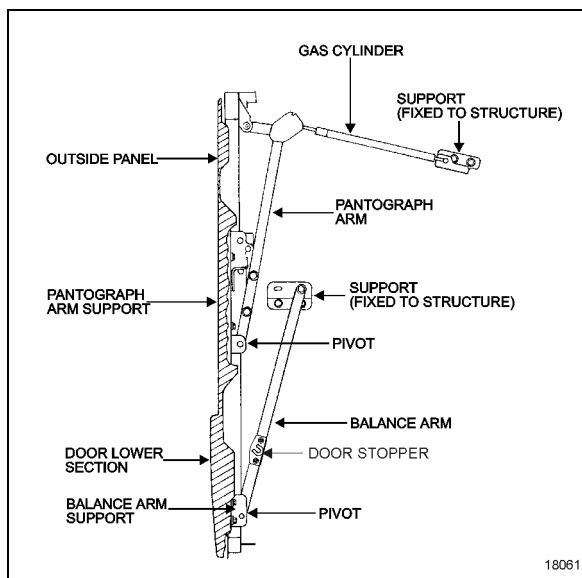

FIGURE 77: BAGGAGE COMPARTMENT DOOR

There are 6 pantograph doors serving as baggage compartment doors on the H3-41, while there are 8 on the H3-45 and the V.I.P (depending on options, VIP model may have even more pantograph doors). Each of these doors is of identical design. A centrally mounted, key-lockable door handle unlatches the door which can then be pulled out and raised up in a path parallel to the side of the vehicle. The door is held in open position by two fully extended gas-charged cylinders, giving clear access to the opening of the baggage compartment.

From its fully open position, the door can be closed by pulling down on the door panel, and letting go when you sense the door will close on its own. The door will easily hinge its way back in the contour of the compartment opening and will be held closed by two latches. Each door can be opened by lifting the centrally mounted handle to unlatch the door and lifting it all the way up. If the door does not remain in the fully open position, one or both gas cylinders on that door is (are) defective. To test the cylinders, first support the door in the fully open position with proper equipment. Disconnect the rod end of one cylinder and try to retract the rod. If strong resistance is felt, the gas cylinder is in good condition and can be reinstalled. If the rod retracts with little effort, the cylinder is defective and should be replaced at once. Test the other cylinder on that door the same way.

NOTE

In case of malfunctioning or in specific situations, use door stoppers to secure the door in the open position.

23.1 PANTOGRAPH ADJUSTMENT

**WARNING**

Park vehicle safely, apply parking brake, stop engine and set batteries master switches to the "OFF" position prior to working on the vehicle.

NOTE

Refer, if needed, to Figure 77 for identification of door components.

If the door bends when opening or if pantograph does not function properly, it is probably because the pantograph arms are misadjusted.

Measure distance between a pantograph arm end and a straight edge resting on structure. Repeat procedure for the other arm. The distance on each side should be equal. If not, bend appropriate arm until desired measure is obtained (Figure 79 & Figure 80).

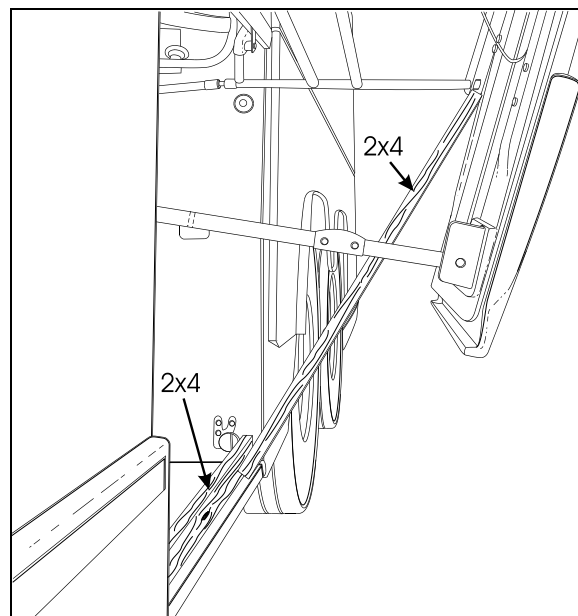

FIGURE 78: PANTOGRAPH ADJUSTMENT

18319

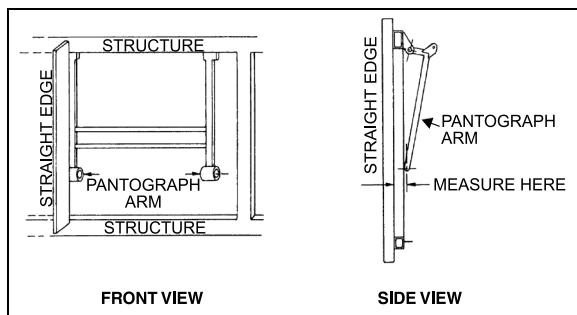

FIGURE 79: PANTOGRAPH DOOR ADJUSTMENT 18062

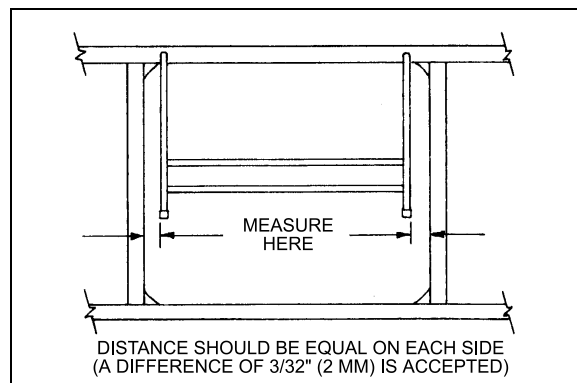

FIGURE 80: PANTOGRAPH DOOR ADJUSTMENT 18063

Doors can be adjusted by bending the arms as follows:

1. Open the door halfway up.
2. Install a piece of wood (a 2x4 will do) along the bottom of the baggage compartment. Arrange so it rests against the striker pins and is prevented from sliding further in the compartment.
3. Install another piece of 2x4 between the first piece and the bottom of the pivot of the lowest (or shortest) pantograph arm, (Figure 78).
4. Pull down on the opposite side of the door to bend the door around the pantograph arm pivot (prevented from moving by the 2x4).
5. When the door is straight, remove the 2x4's and check door operation and fit. A difference of 3/32" (2mm) between both sides is accepted (Figure 80).
6. Repeat as necessary.

24. DOOR HANDLES

Compartment door handles are non-serviceable. When a door handle has to be removed, proceed as follows:

1. Unscrew the four (4) retaining screws;
2. Remove the two (2) wires connecting the handle to the door latch locking mechanisms.
3. To install a new handle, reverse the procedure.

25. ENGINE COMPARTMENT DOOR

The engine compartment rear door (Figure 81) rises in the same way as the baggage compartment doors and is held open by three gas-charged cylinders (Prevost # 980024). The engine compartment opens by lifting a handle accessed from the R.H. side of the engine compartment.

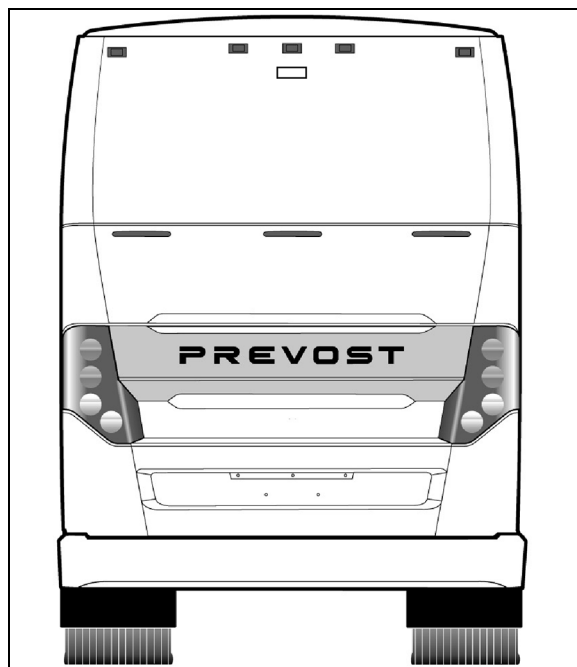

FIGURE 81: ENGINE COMPARTMENT DOOR 18747

When pushed up, the handle pulls on two steel wires, each steel wire connected to its respective door latch locking the rear door. Both steel wires are looped at the release handle and can be adjusted to proper length to ensure positive release of both catches when the handle is raised.

25.1 ENGINE DOOR ADJUSTMENT

As indicated above, the engine door mechanism is similar to the baggage door mechanism using a pantograph and 3 gas cylinders to move the door up and down.

For a minor horizontal or vertical adjustment:

1. Open the door mid-height;
2. With the help of an assistant, pull down one side of door while holding up the other side to bend the pantograph arms in the desired position;
3. Close the door and check the top edge parallelism between the door and the vehicle end cap structure. The space may be somewhere between 10 and 15 mm;
4. Repeat until satisfied.

25.2 MINOR TOP EDGE DEPTH ADJUSTMENT

Two rubber spring loaded stops may be adjusted. They are located near the top edge on each side of the rear door.

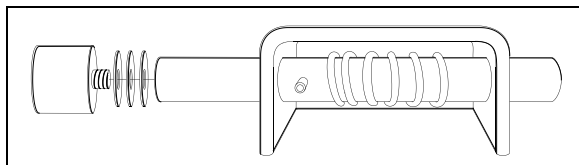

FIGURE 82: DOOR STOP

18324

To adjust:

1. Open door.
2. Unscrew rubber stop.
3. Add or remove washers as needed.
4. Firmly screw back rubber stop.

25.3 MINOR LOWER EDGE DEPTH ADJUSTMENT:

1. Open door.
2. Slightly loosen the striker pins on each side of door.
3. Using a hammer, strike striker pin gently in the desired direction (in or out).
4. Close the door slowly and check fit.
5. Repeat 3 and 4 to adjust the other striker pin.
6. When door depth is completed on the four corners, both vertical door sides should be parallel to the vehicle body structure.
7. Firmly tighten the striker pins (2) to lock them in position.

26. ENGINE AIR INTAKE GRILL

When needed, the engine air intake grill can be changed:

1. Cut the seal around the grill with a sharp edged knife.
2. Remove the grill from the vehicle.
3. On the vehicle grill opening, using the knife, remove as much adhesive as possible.
4. Sand the new grill backing edge to remove the glossy surface.
5. Clean with alcohol, wipe dry.
6. Apply SIKA 205 primer to the grill opening and the grill edges. Allow to dry at least 2 minutes for chemical evaporation.
7. Apply SIKA 255 FC adhesive on the grill edge.
8. Install the grill on the vehicle, adjust and fasten with masking tape. Allow 8 hours setting period.

27. RADIATOR DOOR ADJUSTMENT

27.1 DOOR HEIGHT ADJUSTMENT

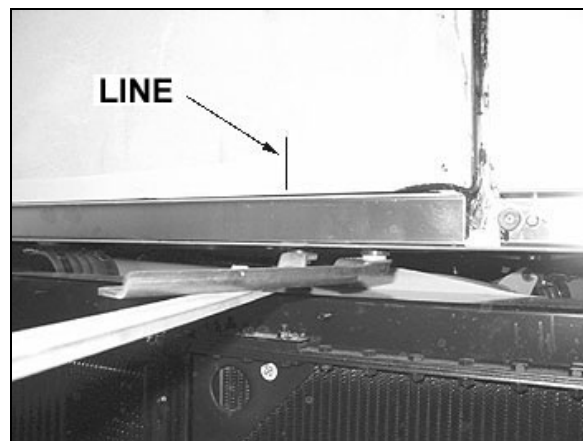

FIGURE 83: REFERENCE LINE

1. Using a pencil, draw a line onto the lateral panel in line with the balance arm.
2. Using a rubber mallet, adjust the lower part of pantograph arm in order to get 4 ± 1 mm between lateral panel and engine door (Refer to Figure 83 and Figure 84).

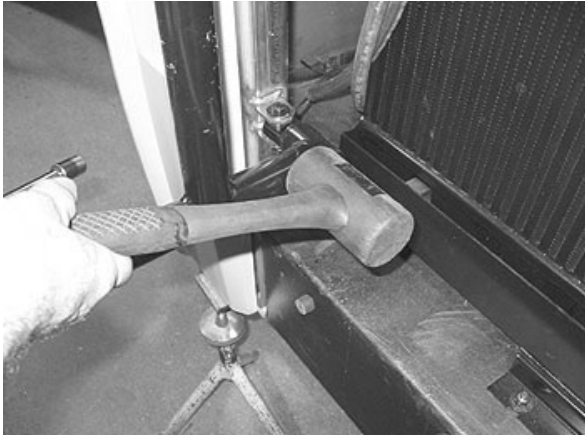

FIGURE 84: PANTOGRAPH ARM ADJUSTMENT

3. Tighten the bolt.

27.2 DOOR LATERAL ADJUSTMENT



FIGURE 85: DOOR LATERAL ADJUSTMENT

1. Using a rubber mallet, adjust radiator door positioning with reference to pantograph arm so that the door is parallel to the lateral panel and to the engine door.
2. Tighten the two bolts.

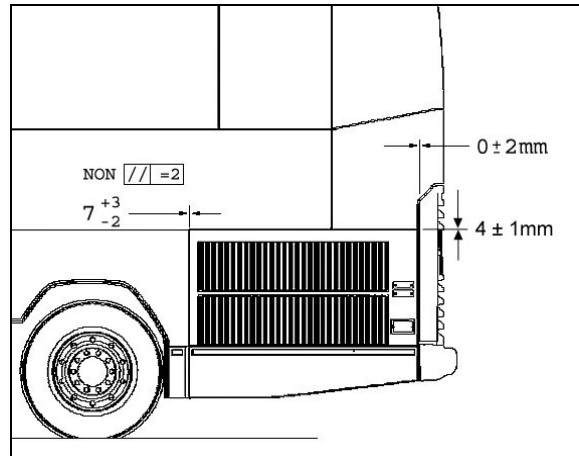

FIGURE 86: PROPER DOOR POSITIONING

27.3 DOOR DEPTH ADJUSTMENT

1. Close radiator door.
2. Check parallelism between radiator door and rear fender (max. 0 ± 2 mm).
3. If the door is too far inside, adjust using a rubber mallet (Refer to Figure 88).
4. Tighten the bolt.
5. Close the radiator door in order to verify that latches adjustment is proper. If the gap is too small or too big, adjust latch positioning.

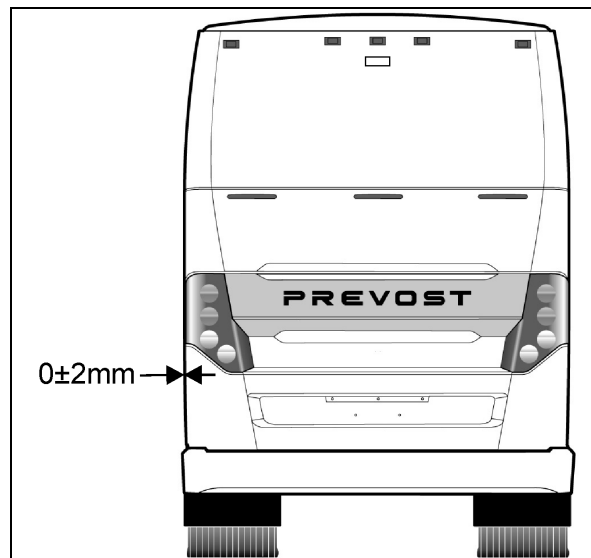

FIGURE 87: DOOR DEPTH ADJUSTMENT

6. Make sure that latch striker pin engages behind the strike plate at least 10 mm. Add or remove spacers if needed. Check door fit and operation. Tighten the latches bolts.



FIGURE 88: DEPTH ADJUSTMENT

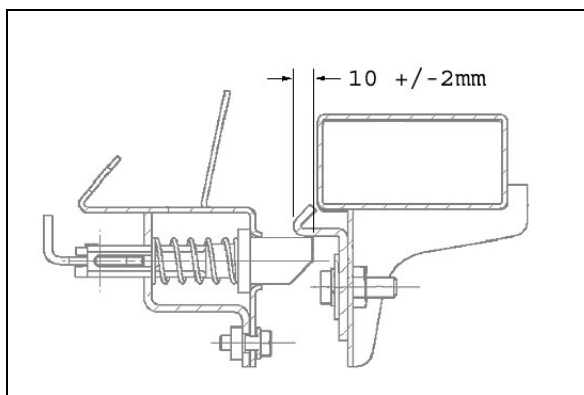

FIGURE 89: DOOR LATCHES ADJUSTMENT

5. Loosen bracket nuts holding the panel to condenser. Panel (6, Figure 90) may be shifted "IN or OUT", "LEFT or RIGHT" and "UP or DOWN".
6. Adjust condenser panel at brackets (2, Figure 90) and (5, Figure 90).
7. Tighten the nuts.
8. Respect the required gap between exterior finishing panels (Figure 72).
9. Check that the door swings freely and closes properly. It may be necessary to adjust the door latch to get proper fit and operation.

28. CONDENSER DOOR ADJUSTMENT

1. Open the condenser door.
2. Loosen the nuts (1, Figure 90) holding the hinge (3, Figure 90) to hinge attachment (4, Figure 90). Loosening nuts (1, Figure 90) allows the condenser assembly to be shifted "LEFT or RIGHT" and "UP or DOWN".
3. Adjust condenser assembly position at the hinge.
4. Tighten the nuts.

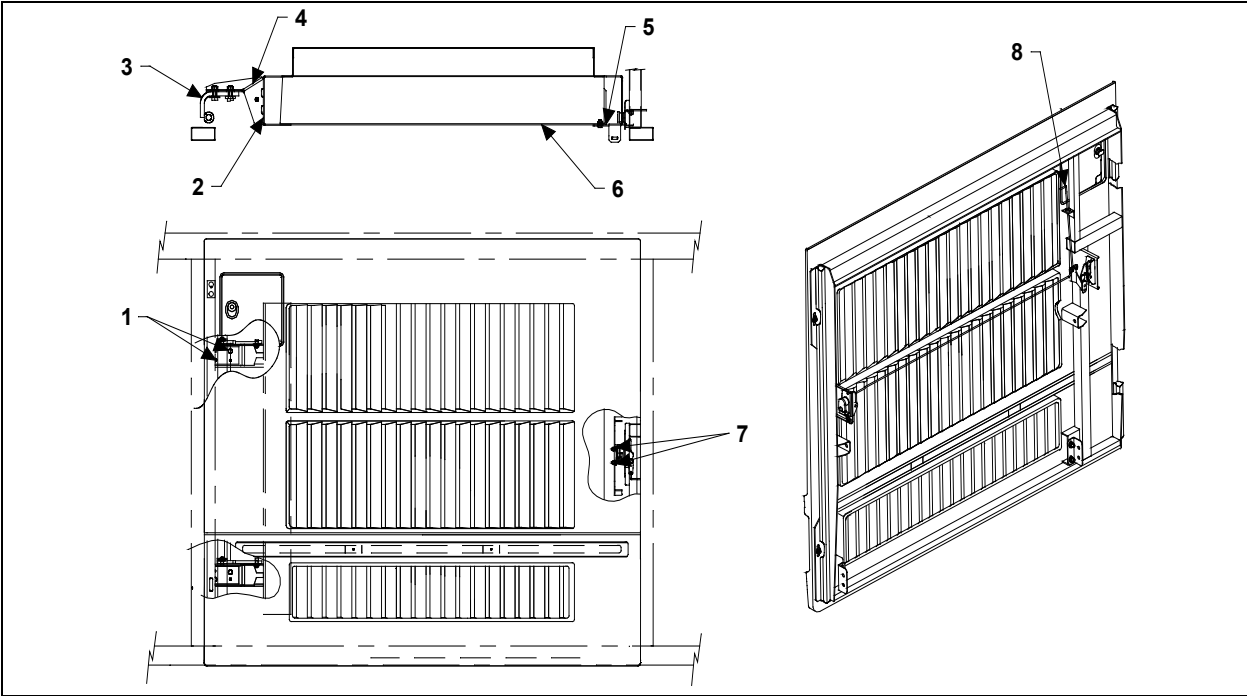

FIGURE 90: CONDENSER DOOR

D280201

29. FUEL FILLER DOOR

1. Open the fuel filler door (1, Figure 91).

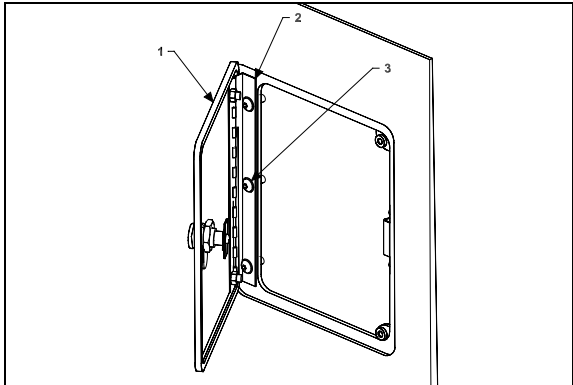

FIGURE 91: FUEL FILLER DOOR

1875003D

2. Loosen the screws (3, Figure 91) holding the panel to hinge (2, Figure 91) assembly.
3. Adjust the fuel filler door position according to distance required between exterior finishing parts (Figure 72).
4. Tighten the nuts.
5. Check that the door swings freely and closes properly.

30. FRONT SERVICE COMPARTMENT

Adjustment of the front service compartment door can be done by following these steps:

1. Open the door.
2. Loosen nut (2, Figure 92).
3. Move part (1, Figure 92), as close as possible to exterior of coach, so as to have enough clearance for proper door opening.
4. Tighten nut (2, Figure 92).
5. Loosen nut (3, Figure 92). Hinge allows the door to be shifted "IN or OUT".
6. Adjust door panel to have the same gap space as neighboring panels or refer to Figure 72 for specified gap space. Only if necessary, use the adjustment allowed by moving part 1, Figure 92.

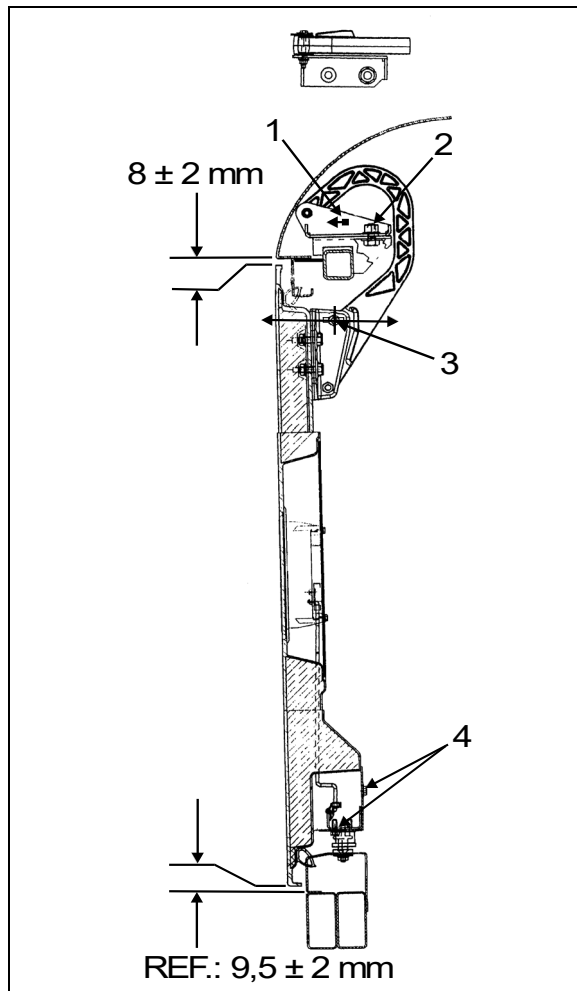

FIGURE 92: DOOR HINGE

18194

7. Loosen screws (5, Figure 93) to allow the door to be shifted "UP or DOWN".
8. Adjust the door position.
9. Tighten the screws.
10. Check that the door swings freely and closes properly. It may be necessary to adjust the door latch to get proper fit and operation.

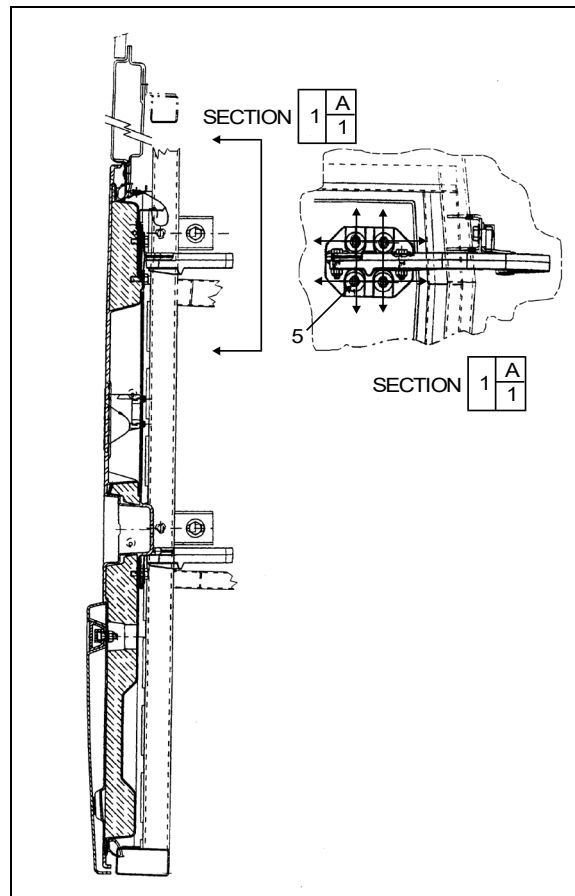

FIGURE 93: FRONT SERVICE DOOR

18195

30.1 LATCH MECHANISM ADJUSTMENT

To adjust the latch mechanism and the striker pin, open the door to access the striker pin. Slightly loosen the striker pin. Using a hammer, adjust the striker pin to center it in the door latch mechanism. Tighten the striker pin. Check door fit and operation.

31. ENGINE COMPARTMENT R.H. SIDE DOOR

The engine compartment R.H side door can be adjusted by following these steps:

1. Open the door.
2. Loosen nut (1, Figure 94).
3. Move part (3, Figure 94) as shown in figure for "LEFT or RIGHT" adjustment.
4. Tighten nut (1, Figure 94).
5. Loosen nut (2, Figure 94).

6. Hinge allows the door to be shifted "IN or OUT".
7. Adjust the door in accordance with the required distance between exterior finishing parts (Figure 72).
8. Loosen screws (4, Figure 95).
9. Screws allow the door to be shifted "UP or DOWN".
10. Adjust the door position according to the distance required between exterior finishing parts (Figure 72).
11. Tighten the screws.

Check that the door swings freely and closes properly. It may be necessary to adjust the door latch to get proper fit and operation.

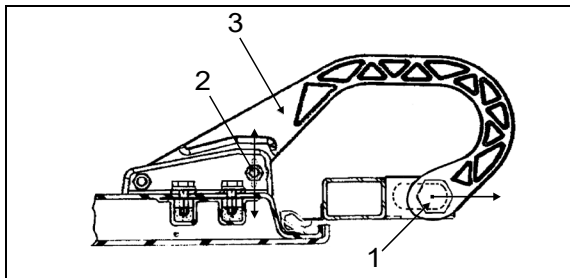

FIGURE 94: DOOR HINGE 18196

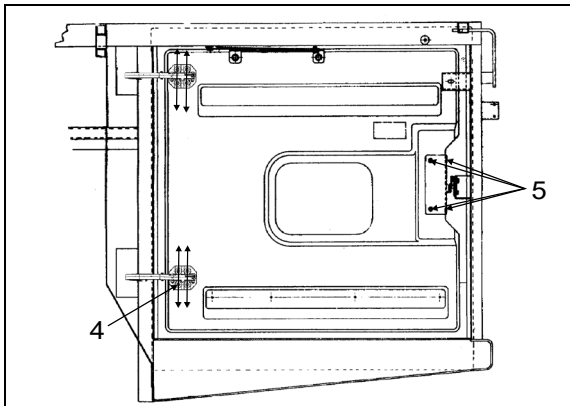

FIGURE 95: ENGINE COMPARTMENT R.H. DOOR 18197

31.1 LATCH MECHANISM ADJUSTMENT

To adjust the latch mechanism and the striker pin, open the door to access the striker pin. Slightly loosen the striker pin. Using a hammer, adjust the striker pin to center it in the door latch mechanism. Tighten the striker pin. Check door fit and operation.

32. EVAPORATOR DOOR ADJUSTMENT

1. Open the door.
2. Loosen nut (1, Figure 96).
3. Move part as shown in figure for "LEFT or RIGHT" adjustment.
4. Tighten nut (1, Figure 96).
5. Loosen nut (2, Figure 96). Hinge allows the door to be shifted "IN or OUT".
6. Adjust the door in accordance with the required distance between exterior finishing parts (Figure 72).
7. Loosen screws (3, Figure 96). Screws allow the door to be shifted "UP or DOWN".
8. Adjust the door position according to the distance required between exterior finishing parts (Figure 72).
9. Tighten the screws.

Check that the door swings freely and closes properly. It may be necessary to adjust the door latch to get proper fit and operation.

32.1 LATCH MECHANISM ADJUSTMENT

1. To adjust the latch mechanism and the striker pin:
2. Open the door to access the striker pin.
3. Loosen slightly the striker pin.
4. Using a hammer, adjust the striker pin to center it in the door latch mechanism.
5. Tighten the striker pin. Check door fit and operation.

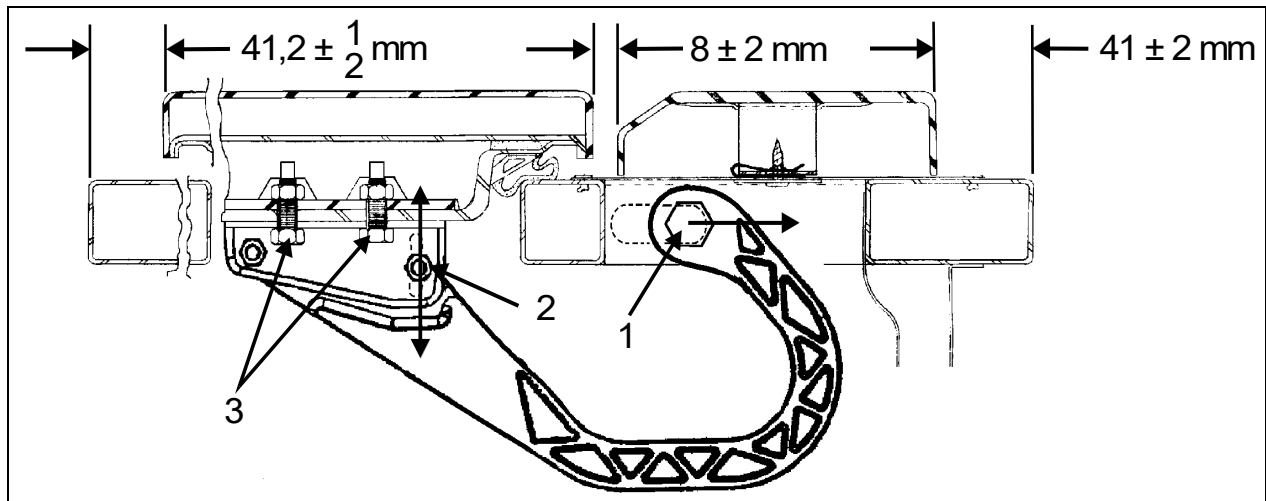

FIGURE 96: EVAPORATOR DOOR

18198

33. MAIN POWER COMPARTMENT

To adjust the main power compartment door:

1. Loosen nut (1, Figure 97).

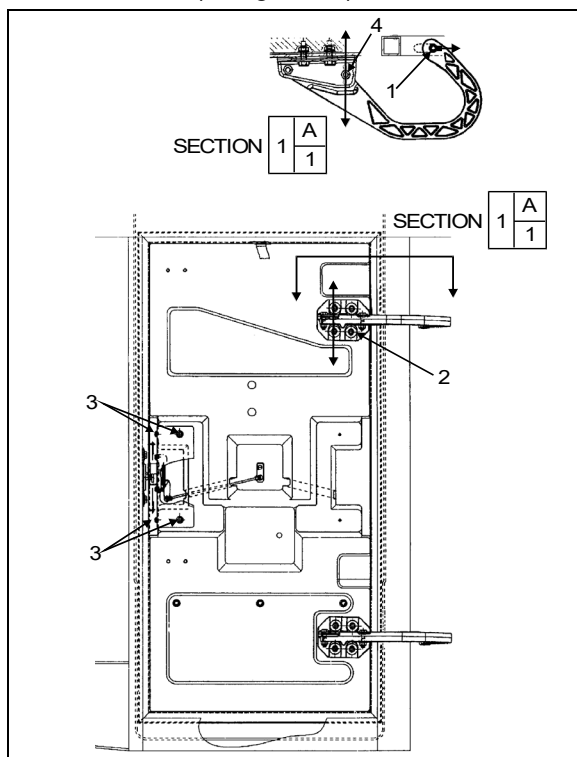

FIGURE 97: MAIN POWER COMP. DOOR

18199

2. Move part as shown in figure for "LEFT or RIGHT" adjustment.
3. Tighten nut (1, Figure 97).
4. Loosen nut (4, Figure 97).

5. Hinge allows the door to be shifted "IN or OUT".
6. Adjust door panel to have the same gap space as neighboring panels or refer to Figure 72 for specified gap space
7. Loosen screws (2, Figure 97). Screws allow the door to be shifted "UP or DOWN".
8. Adjust the door position.

Tighten the screws.

Check that the door swings freely and closes properly. It may be necessary to adjust the door latch to get proper fit and operation.

33.1 LATCH MECHANISM ADJUSTMENT

To adjust the latch mechanism and the striker pin:

1. Open the door to access the striker pin.
2. Loosen slightly the striker pin.
3. Using a hammer, adjust the striker pin to center it in the door latch mechanism.
4. Tighten the striker pin.

Check door fit and operation.

34. FENDERS

On the "H" series vehicle, all fenders are easily removable for maintenance on brakes and suspension. Each rear fender has three

mechanical spring-loaded holding devices fixing it to the vehicle's structure.

34.1 REAR FENDER REMOVAL

1. Push the spring type rod sideways so that the lock disengages.
2. Support or have somebody hold the fender up.
3. As in 1, repeat to release both remaining holding devices.
4. Holding the fender firmly, pull it down until the top edge disengages from the holding plates.

To reinstall, reverse the procedure.

34.2 FRONT FENDER REMOVAL

1. At the bottom of fender, remove the retaining screws on one side of the fender.
2. Support or have someone hold the fender up.
3. Remove the screw on the other side of the fender.
4. Pull the fender down until the top edge disengages from the holding plates.

To reinstall, reverse the procedure.

35. REAR CAP

The fiberglass rear cap does not need any maintenance except painting as needed. For minor damages, refer to section 4 "Fiberglass Repair" and section 5 "Painting". If the rear cap ever has to be replaced:

1. Remove all accessories.
2. Drill out the retaining pop rivets.
3. With a sharp edge blade, cut the seal joint and remove the rear cap.
4. With the sharp edge blade, remove as much of the remaining seal pieces as possible.
5. Sand with #120 or #150 sandpaper.
6. Wipe clean with alcohol
7. Prepare surface with SIKA #205 and let dry for a minimum of 2 minutes.
8. Install a new seal using LOCTITE 414 glue.

9. Install the rear cap and fasten with pop rivets.



CAUTION

Do not attempt this procedure unless you are qualified and equipped to handle this job.

36. FRONT CAP

The front cap windshield frame does not need any maintenance. It is held in place with bolts and nuts. If it ever has to be replaced, make an appointment at a Prevost service center near you.

37. SIDE PANEL INSTALLATION PROCEDURE FOR COACHES AND VIP

Material:

Anti-silicone (682989)	√	Blue cloth (682383)	√	Sika 206 G+P 1 liter (683446)	√
Tack cloth	√	Pure water	√	Sika 252 black	√
CHIX cloth (682384)	√	Scotchbrite gray (680226)	√	Masking tape	√

Equipment:

Glue gun	√	
Compression roller	√	

SECTION #1 SIDE PANEL INSTALLATION	
1.00	<p>SS Body structure preparation</p> <p>A) Clean using anti-silicone. See SAV000001 section A. Use Scotchbrite to sand structure. Use 1 side of Scotchbrite for 1 side of vehicle.</p>

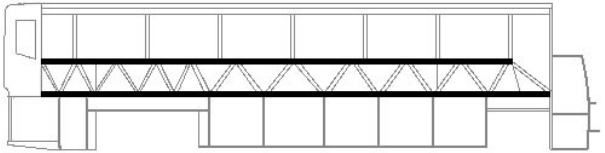
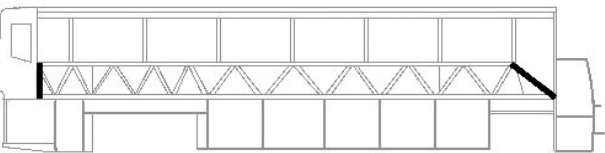

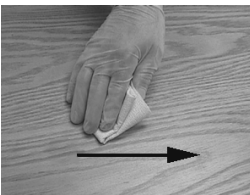

SAV000001 Section A Alcohol or Anti-silicone							
	<p>1. Apply</p> <p style="background-color: yellow; border: 1px dashed black; padding: 2px; display: inline-block;">CHIX cloth</p>						
	<p>2. Dry immediately</p> <p style="background-color: blue; border: 1px dashed black; padding: 2px; display: inline-block; color: white;">Blue cloth</p>						
<p>3. Allow to dry</p> <table border="1" style="width: 100%; border-collapse: collapse;"> <tr> <td style="width: 20%;">Mandatory</td> <td>Minimum time : Wait for product to evaporate</td> </tr> <tr> <td></td> <td>After 2 hours: Start cleaning operation again</td> </tr> <tr> <td>Before applying any other product</td> <td>If surface seems dusty, greasy or with finger marks, start cleaning operation again.</td> </tr> </table>		Mandatory	Minimum time : Wait for product to evaporate		After 2 hours: Start cleaning operation again	Before applying any other product	If surface seems dusty, greasy or with finger marks, start cleaning operation again.
Mandatory	Minimum time : Wait for product to evaporate						
	After 2 hours: Start cleaning operation again						
Before applying any other product	If surface seems dusty, greasy or with finger marks, start cleaning operation again.						

1.05	Fiberglass panel preparation (fiber side)
------	--

A)	Clean using tack cloth. Repeat if surface seems dusty.	
B)	Clean using anti-silicone See SAV000001 section A.	
C)	Apply primer 206 G+P. See SAV000001 section D.	

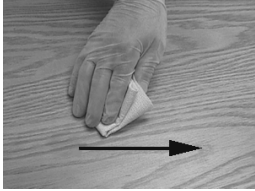
SAV000001 Section D Sika Primer 206 G+P



3. Shake bottle to mix product

4. Apply a thin layer

CHIX cloth



3. Allow to dry

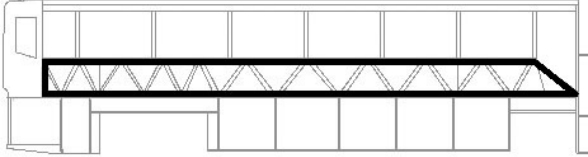
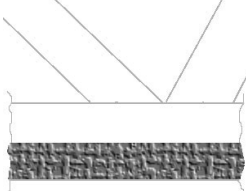

		Minimum time : 10 minutes
Mandatory	206 G+P	After 2 hours: Remove dust using damp cloth (pure water)
		After 8 days : Reactivate with Aktivator as per section "C"

Before applying any other product

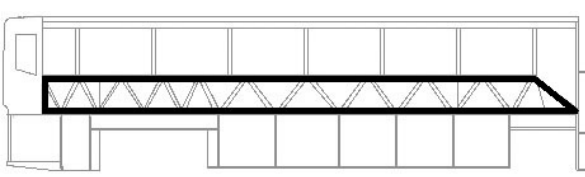
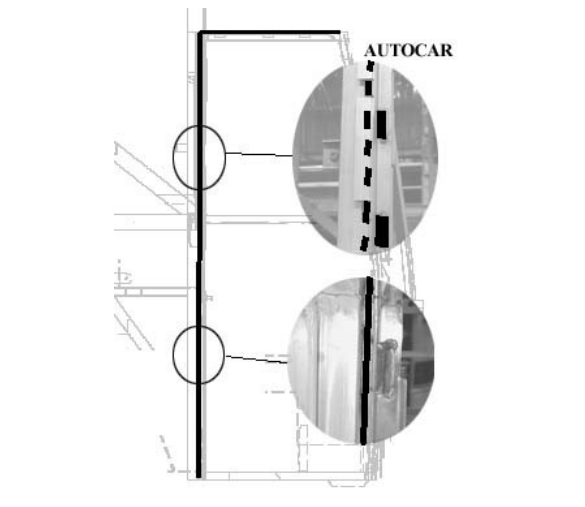

- If surface seems dusty, dust using damp cloth.
- If surface seems greasy or with finger marks, reactivate with Aktivator.

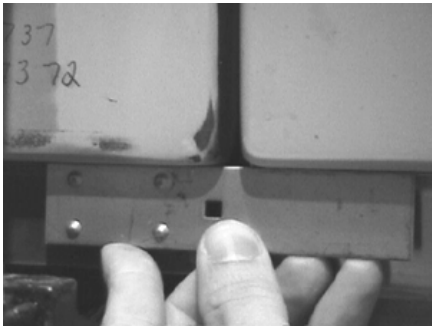
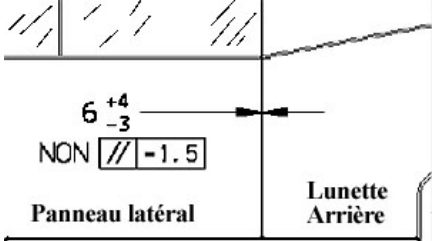
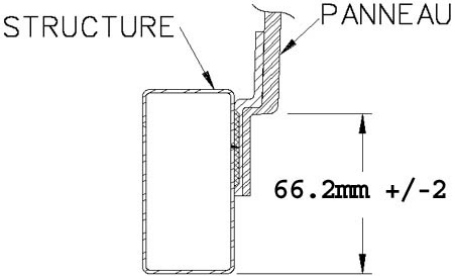
1.10	SS Body structure preparation	
A)	Clean using anti-silicone. Clean structure at least twice. Repeat is necessary until cloth comes clean. See SAV000001 section A.	
B)	Apply 1 ¼" protective tape along bottom structural tubing.	

	C)	Apply 206 G+P onto structure. See SAV000001 section D.	
1.15		Seal entrance door perimeter using Sika 252 black, Smooth down the excess.	
1.20		Install lateral panel supports onto bottom structural tubing. Install lateral panel onto supports to verify proper positioning.	
1.25	Glue application		
	A)	Set (timer) or record time.  No more than 45 minutes should elapse between beginning of glue application and panel installation.	
	B)	Apply Sika 252 black onto structure 	
1.30 *	A)	Install lateral panel onto supports and clamp panel in place using "C" clamps and square tubing to even out the pressure. Note: A maximum of clamps should be used (every 6 inches) to ensure proper bonding. Do not tighten too much.	

	<p>B) At the rear, adjust panel height so that it is level with rear cap</p>	
	<p>C) Gap between lateral panel and rear cap must be 6mm +4/-3 and panels must be aligned within 1.5mm.</p>	
	<p>D) Using a ruler, adjust front of lateral panel.</p>	
	<p>E)  Verify if panel upper corner is in the middle of window post.</p>	
<p>1.55</p>	<p>Remove excess of glue using a spatula.</p> <p>Apply a bead of Sika 252 at the top of panel</p> <p>Spray pure water onto all the joints to speed up drying process</p>	

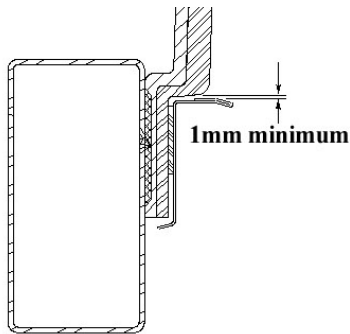
1.60	Remove protective tape (installed at step 1.10b).
1.70	Do not move the vehicle for 48 hours Make sure room temperature is superior to 20°C (68°F) before gluing Perform a visual inspection before installing side windows

SECTION #2 DRIP MOLDING INSTALLATION			
2.00 *	A)	Clean using Anti-silicone See SAV000001 section A.	
	B)	Apply Sika 206 G+P See SAV000001 section D.	
2.05	Remove blue paper from drip molding. Remove protective tape from double-face self adhesive tape		
2.10	Glue drip molding. Allow a gap of 1mm minimum between top of drip molding and panel.		
2.15	Compress drip molding using the compression roller to increase adherence.		
2.20	Round off rear and front drip molding corners.		

SECTION #3 REPAIR	
4.00	Remove fiberglass from structure using a screwdriver. Use wedges if necessary to hold down panel during the work.
4.05	Remove as much glue as possible. If primer is removed, apply primer 206 G+P locally. If primer is OK, reactivate as per SAV000001 section D.
4.10	Apply Ultrafast 2 glue (heated).
4.15	Compress panel using clamps and a metal flat bar (for an even compression). Only use screws as a last resort to compress.
4.20	Vehicle must not move for the next 12 hours.

38. REAR-VIEW MIRROR

The exterior rear-view mirrors are equipped with a flat glass as well as a convex glass mirror.

Flat and convex glass mirrors may be equipped with an optional electric heating system which serves to minimize ice and fog on the mirror glass. Integral thermostats are installed to prevent continuous heating.

Use the appropriate switch on the dashboard to activate the defogger system on both mirrors simultaneously.

Flat and convex glass mirrors can easily be replaced in case of breakage.

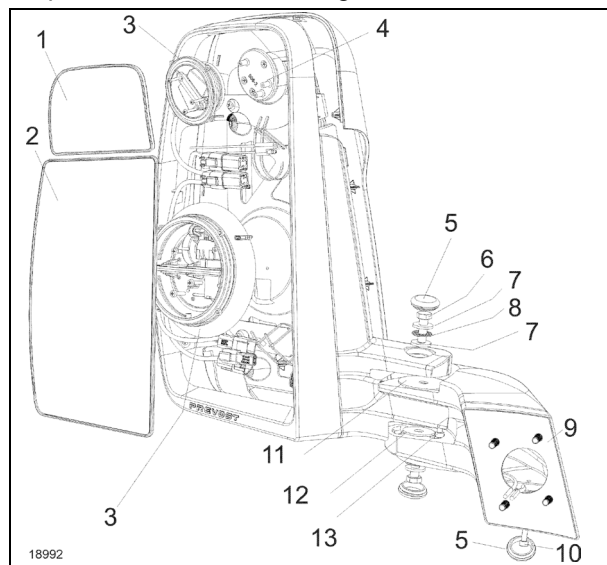

FIGURE 98: REAR-VIEW MIRROR (STREET SIDE SHOWN)

#	DESCRIPTION	QTY
1	CONVEX GLASS MIRROR	1
2	FLAT GLASS MIRROR	1
3	SMALL 24V MOTOR ASM PREVOST	1
3	LARGE 24V MOTOR ASM PREVOST	1
4	SMALL MOTOR PLATE	1
5	BLACK PLASTIC CAP	3
6	ARM BOLT	2
7	THRUST BEARING WASHER	4
8	THRUST BEARING WASHER	2
9	RS SHIM W/ GASKET	1
10	CLAMPING SCREW	1
11	LARGE FRICTION WASHER, 33GF NYLON	1
12	SMALL FRICTION WASHER, 33GF NYLON	1
13	M6 X 12 mm HEX SOCKET HEAD CAP SCR	1

See paragraph 1 TORQUE TABLES in Section 18A for prescribed torque.

38.1 ARM AND BRACKET POSITION

Arm and bracket should be positioned so that the surfaces are flush as shown on the images below.

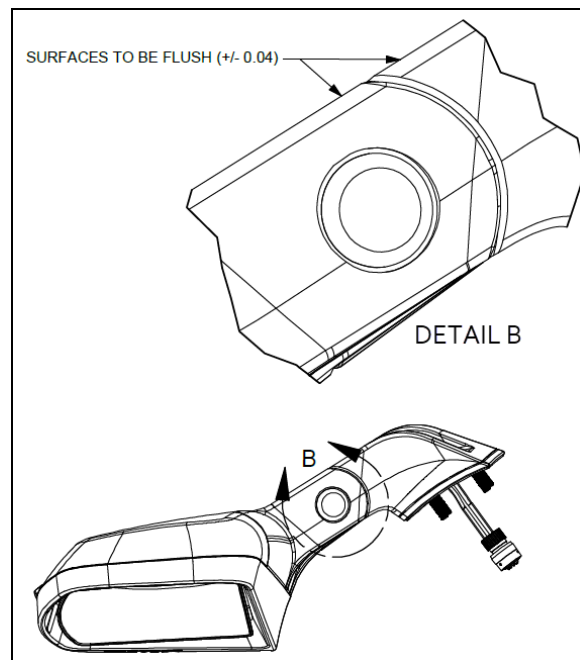

FIGURE 99: STREET SIDE REAR-VIEW MIRROR

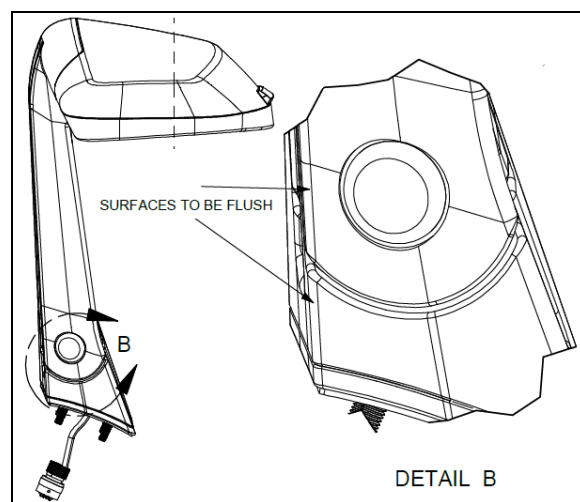

FIGURE 100: CURBSIDE REAR-VIEW MIRROR

38.2 REAR-VIEW MIRROR REMOVAL

To remove the complete rear-view mirror unit, proceed as follows:

1. Remove the black plastic cap (Figure 101).

- Loosen the clamping screw (do not remove) so that the mirror unit can be lifted from the mounting plate (Figure 101).

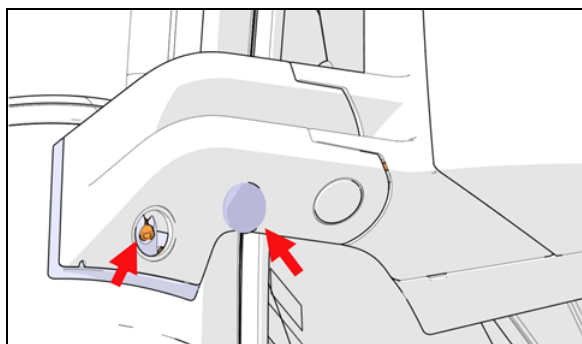

FIGURE 101

- Lift the mirror unit (E1, Figure 102) from the mounting plate and tilt (E2, Figure 102) so it detaches from the mounting plate.

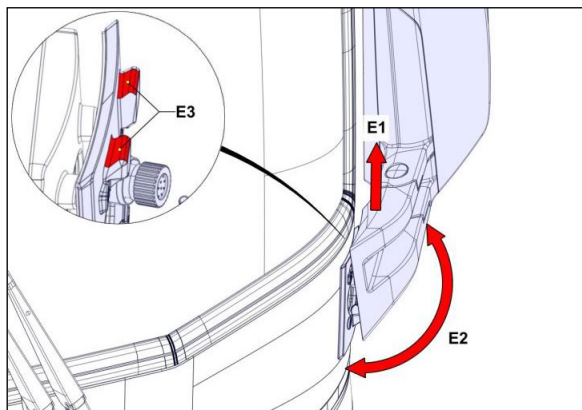

FIGURE 102

- Unplug the connector.

38.3 REPLACEMENT OF FLAT GLASS MIRROR

The flat glass mirror assembly is mounted to a lock ring which is part of the motor assembly.

- Underneath the mirror, reach for the tab of the locking ring (item 2, Figure 103).

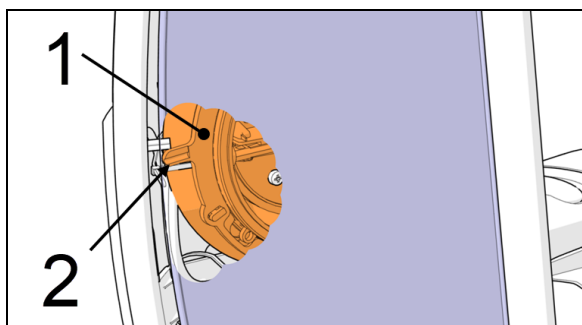

FIGURE 103: (1) LOCK RING; (2) TAB

- Use tool 990684 to rotate the lock ring by pushing the tab downwards on the R.H. mirror or upwards on the L.H. mirror (Figure 104).



FIGURE 104: TOOL

- Detach the flat mirror.
- Disconnect the heater wires.
- Remove the lock ring from the motor (item 1, Figure 105).

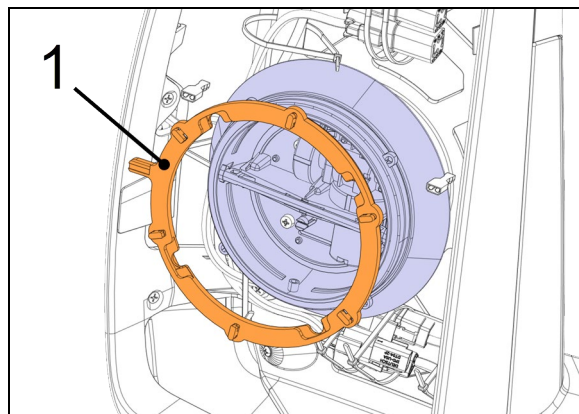

FIGURE 105: (1) LOCK RING

- Install the lock ring on the new glass mirror (item 1, Figure 106).

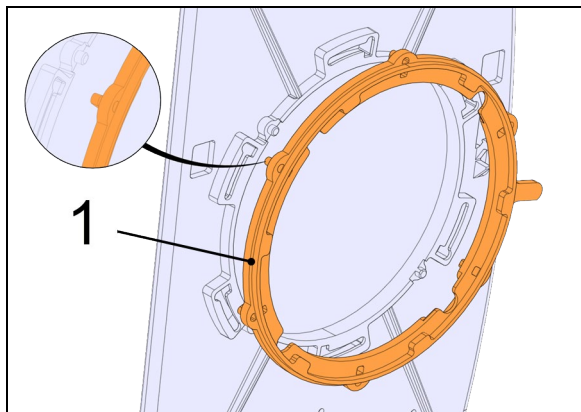

FIGURE 106: (1) LOCK RING

7. Adjust the lock ring to center the pin (4x) in the notch of lock ring.
8. Install the new glass mirror pin (4x) into the motor holes (4x) (Figure 107).

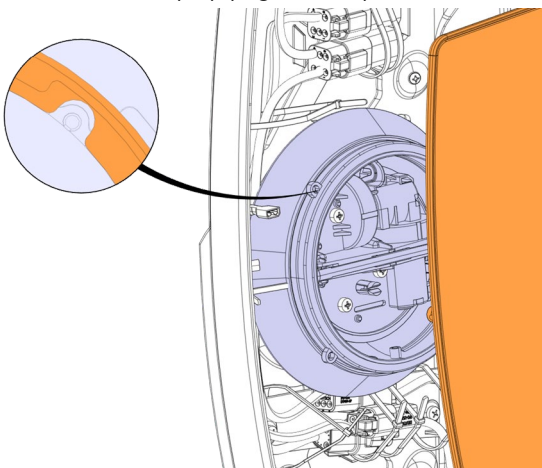

FIGURE 107

9. Use tool 990684 to push lock ring tab upwards right-hand mirror or downwards for left-hand mirror to lock the mirror glass in place. (Figure 104).

38.4 REPLACEMENT OF CONVEX GLASS MIRROR

The snap mounted convex mirror is mounted to a ring which is part of the motor assembly. Replaced as follows.

1. Remove the mirror by pulling gently on the side of the mirror.
2. Detach the mirror from the motor assembly mounting ring.
3. Disconnect the heater wires.

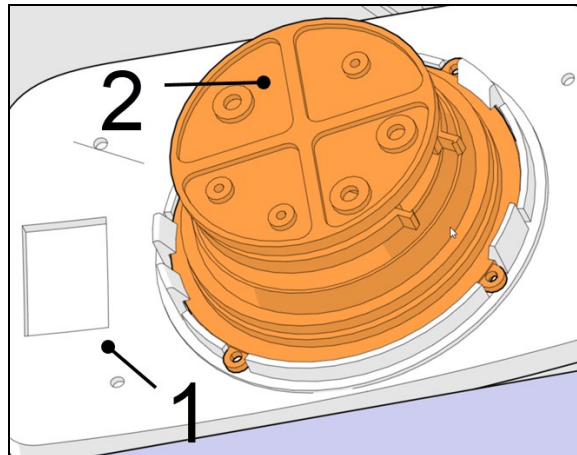

FIGURE 108: (1) CONVEX GLASS MIRROR; (2) MOTOR



CAUTION

Do not attach stick-on type convex mirror accessories to the heated mirror glass. This could impede uniform heat distribution on the mirror surface which could break the mirror.

SPECIFICATIONS

Door cylinder

Manufacturer Bimba
 Type Pneumatic
 I.D. 1½" (mm)
 Stroke..... 8" (mm)

Damper

Manufacturer Koni

Lock cylinder (upper)

Manufacturer Bimba
 Type Air, single action, 1/8 NPT, hexagonal rod
 I.D. 7/8" (22 mm)
 Stroke..... 1" (25 mm)

Lock cylinder (central)

Manufacturer Bimba
 Type Air, single action, ¼ NPT
 I.D. 1¾" (45 mm)
 Stroke..... 1" (25 mm)

Manifold solenoid

Manufacturer Norgren
 Type 4 ports, 1/8 NPT
 Voltage 24 VDC
 Power consumption..... 6 watts
 Maximum pressure..... 150 psi (1035 kPa)

Solenoid valve (Latching valve)

Manufacturer Humphrey
 Model 310
 Operating range 0 to 125 psi (0 to 860 kPa)
 Voltage 24 VDC
 Voltage tolerance +10%, -15% of rated voltage
 Power consumption..... 4 watts
 Leak rate (max allowed)..... 0.245 in³/min @ 100 psi (4cc/min @ 690 kPa)
 Type of operation Direct solenoid
 Lubrication Not required (factory pre-lubed)
 Filtration 40 micron recommended



**MAINTENANCE
INFORMATION**

MI15-18

DATE :	MAY 2015	SECTION :	18 - Body
SUBJECT :	STRUCTURE INSPECTION FOR CORROSION - HOW TO PREVENT CORROSION		

IMPORTANT NOTICE
This maintenance is recommended by PrevoSt to increase your vehicle's performance. Note that no reimbursement will be awarded for carrying out this maintenance.

APPLICATION

Model	VIN
 <p>All PrevoSt models</p>	

DESCRIPTION

This procedure was made in order to support PrevoSt customers who are worried about their vehicle structure behavior due to corrosion.

Five year old vehicles and older should be subjected to a thorough structural inspection; especially if clear signs of moderate or deep corrosion are visible. The inspection can be conducted as described in the following procedure.

In this procedure, you will find information about:

- 1) The important areas that should be inspected**
- 2) When a structural inspection should be carried out**
- 3) How to perform the inspection**
- 4) What can be done to optimize corrosion protection during your vehicle's life**

STRUCTURE INSPECTION – CORROSION	
DESCRIPTION	INTERVAL
Perform structural inspection for corrosion as described in this document	Normal duty cycle vehicles and normal environment operation Every 5 years starting from the 5 th year in service
	Severe duty cycle vehicles and harsh environment operation Every 2 years starting from the 5 th year in service
	Whenever a <i>visual inspection</i> discloses that corrosion seems to have caused damages to the structure such as perforation, flaking, separation of metal layers, loss of material, etc.



CAUTION

Reject member, chassis component, axle, etc. if:

Cracked, broken, separated by corrosion or corroded to a depth as to weaken member so as to affect the safety and structural integrity of the vehicle.



DANGER

Park vehicle safely, apply parking brake, stop engine. Prior to working on the vehicle, set the ignition switch to the OFF position and trip the main circuit breakers equipped with a trip button. On Commuter type vehicles, set the battery master switch (master cut-out) to the OFF position.

THE IMPORTANT AREAS THAT SHOULD BE INSPECTED

Front & rear sub-frames, drive axle cradle and tag axle (FIGURE 1) on Prevost structures are made of high strength steel. Although the structure on a Prevost vehicle receives a beneficial corrosion preventive compound application at the end of the manufacturing process, after many years of service with exposure to harsh environments (winter, frequent rains, road salt, stone projection, sand accumulation, etc.), the carbon steel can be subject to severe corrosion. The use of high strength steel remains a requirement to withstand peak loads.

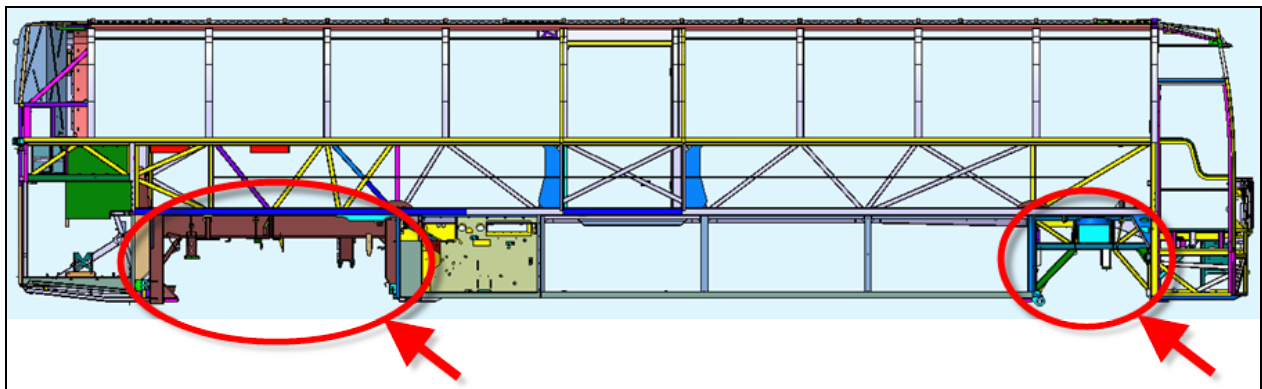

FIGURE 1 – CRITICAL AREAS: FRONT SUB-FRAME, REAR SUB-FRAME, DRIVE AXLE CRADLE AND TAG AXLE

WHEN SHOULD A STRUCTURE INSPECTION BE CARRIED OUT?

Vehicles operating in harsh environments without an appropriate corrosion protection compound applied to the front and rear sub-frames, drive axle cradle and tag axle could be subject to corrosion. If parts of the tag axle or front and rear sub-frames structures present metal flaking, separation of metal layers, loss of material, perforation, etc. then they should be inspected in order to confirm that the minimum wall thickness remains (FIGURE 2 to FIGURE 5).



FIGURE 2: METAL FLAKING. ACCUMULATED SAND AS SHOWN ON THE IMAGE SHOULD NOT BE LEFT IN PLACE



FIGURE 3: METAL FLAKING AND ACCUMULATED SAND



FIGURE 4: METAL FLAKING ON TAG AXLE - ACCUMULATED MATTER WILL RETAIN WATER THUS CREATING CONDITIONS PROMOTING ADDITIONAL CORROSION



FIGURE 5: HEAVILY CORRODED COACH WITH BROKEN TAG AXLE. THIS IMAGE SHOWS THE SPINDLE MOUNTING PLATE SEPARATED FROM THE REST OF THE TAG AXLE

STRUCTURE INSPECTION PROCEDURE

The thickness of main carbon steel parts on rear & front sub-frames, drive axle cradle and tag axle beam must be **at least 1/8 inch (0.125") (3mm)**. There are two options to properly monitor the wall thicknesses:

- 1- Using an ultrasonic wall thickness gauge.
- 2- Drilling holes and measuring wall thickness.

1- Structural Inspection Procedure Using Ultrasonic Wall Thickness Gauge

The ultrasonic wall thickness gauge has to be used on bare metal. The surface where the gauge will be put on has to be cleaned of rust, paint or other material. If the thickness is more than 1/8 inch (3mm), repaint the cleaned surface to prevent corrosion from occurring on this spot.

Use a grinder or another tool to remove rust or paint on the spot to check. The gauge has to be placed on the center of the cleaned spot. The gauge has to be perpendicular to the surface to get an accurate measure.

Inspection using ultrasonic wall thickness gauge is recommended over drilling holes because it minimize risk of altering the vehicle structure.



FIGURE 6: CLEANED SPOT ON STRUCTURAL MEMBER

2- Structural Inspection Procedure Using Drilled Holes

Drill a 1/4 inch (6 mm) diameter hole in the most corroded wall of the part being checked. Use a caliper to measure the thickness of the drilled metal. Wall thickness should be at least 1/8 inch (0.125") (3mm). Drilled hole must then be welded (filled with metal) and repainted after measurement to prevent water infiltration and corrosion from occurring around the hole.

Clean/remove flaking rust on frame. Drill hole in the most corroded wall. The hole must be welded after to prevent corrosion and water infiltration. Filled hole must be painted to prevent corrosion.



CAUTION

Holes and welding can increase the risk of crack initiation. **Ultrasonic wall thickness gauge method is recommended.**



FIGURE 7: HOLE DRILLED IN STRUCTURAL MEMBER

CORROSION PROTECTION ON OLD AND CORRODED FRAME

To maximize corrosion resistance on older frame exposed to harsh environment:

- 1) Clean rust on frame. If available, use sand blasting.
- 2) Apply a zinc-rich primer on cleaned surfaces.
- 3) Cover carbon steel parts with corrosion preventive compound Tectyl 185GW.



CAUTION

Avoid primer, paint, and corrosion preventive compounds on pneumatic valves and rubber bushings.



FIGURE 8: CLEAN RUST

PROTECTION TO PREVENT CORROSION

Tectyl 185GW should be used to prevent corrosion propagation on frame.

- 1) Clean rust and dirt on the frame.
- 2) Apply Tectyl following the manufacturer's recommendation.
- 3) Apply Tectyl every year or as needed.



CAUTION

Avoid primer, paint, and corrosion preventive compounds on pneumatic valves and rubber bushings.



FIGURE 9: TECTYL 185GW BLACK APPLICATION

For more details on Tectyl 185GW, see QC Lubricants web site:

<http://www.qclubricants.com/TECTYL185GWBlack.htm>

Tectyl 185GW Black

QC Lubricants carries Tectyl 185GW Black in pails and drums.

TECTYL® 185GW Black is a solvent cutback, thixotropic corrosion preventive compound. The dry film is semi-firm and has a semi-gloss appearance. TECTYL® 185GW Black provides outstanding protection in marine, tropical, and industrial environments, and is widely used for transportation equipment. TECTYL® 185GW Black possesses dielectric strength of 800 volts per dry mil of coating. TECTYL® 185GW Black provides galvanic corrosion protection and can be applied on battery terminals for insulating purposes.



PARTS / WASTE DISPOSAL

Discard according to applicable environmental regulations (Municipal/State[Prov.]/ Federal)



Access all our Service Bulletins on <https://secureus5.volvo.com/technicalpublications/en/pub.asp>
Or scan the QR-Code with your smart phone.

E-mail us at technicalpublications_prev@volvo.com and type "ADD" in the subject to receive our warranty bulletins
by e-mail.



**MAINTENANCE
INFORMATION**

MI15-18

DATE :	MAY 2015	SECTION :	18 - Body
SUBJECT :	STRUCTURE INSPECTION FOR CORROSION - HOW TO PREVENT CORROSION		

IMPORTANT NOTICE
This maintenance is recommended by PrevoSt to increase your vehicle's performance. Note that no reimbursement will be awarded for carrying out this maintenance.

APPLICATION

Model	VIN
<p>All PrevoSt models</p>	

DESCRIPTION

This procedure was made in order to support PrevoSt customers who are worried about their vehicle structure behavior due to corrosion.

Five year old vehicles and older should be subjected to a thorough structural inspection; especially if clear signs of moderate or deep corrosion are visible. The inspection can be conducted as described in the following procedure.

In this procedure, you will find information about:

- 1) The important areas that should be inspected**
- 2) When a structural inspection should be carried out**
- 3) How to perform the inspection**
- 4) What can be done to optimize corrosion protection during your vehicle's life**

STRUCTURE INSPECTION – CORROSION	
DESCRIPTION	INTERVAL
Perform structural inspection for corrosion as described in this document	Normal duty cycle vehicles and normal environment operation Every 5 years starting from the 5 th year in service
	Severe duty cycle vehicles and harsh environment operation Every 2 years starting from the 5 th year in service
	Whenever a <i>visual inspection</i> discloses that corrosion seems to have caused damages to the structure such as perforation, flaking, separation of metal layers, loss of material, etc.



CAUTION

Reject member, chassis component, axle, etc. if:

Cracked, broken, separated by corrosion or corroded to a depth as to weaken member so as to affect the safety and structural integrity of the vehicle.



DANGER

Park vehicle safely, apply parking brake, stop engine. Prior to working on the vehicle, set the ignition switch to the OFF position and trip the main circuit breakers equipped with a trip button. On Commuter type vehicles, set the battery master switch (master cut-out) to the OFF position.

THE IMPORTANT AREAS THAT SHOULD BE INSPECTED

Front & rear sub-frames, drive axle cradle and tag axle (FIGURE 1) on Prevost structures are made of high strength steel. Although the structure on a Prevost vehicle receives a beneficial corrosion preventive compound application at the end of the manufacturing process, after many years of service with exposure to harsh environments (winter, frequent rains, road salt, stone projection, sand accumulation, etc.), the carbon steel can be subject to severe corrosion. The use of high strength steel remains a requirement to withstand peak loads.

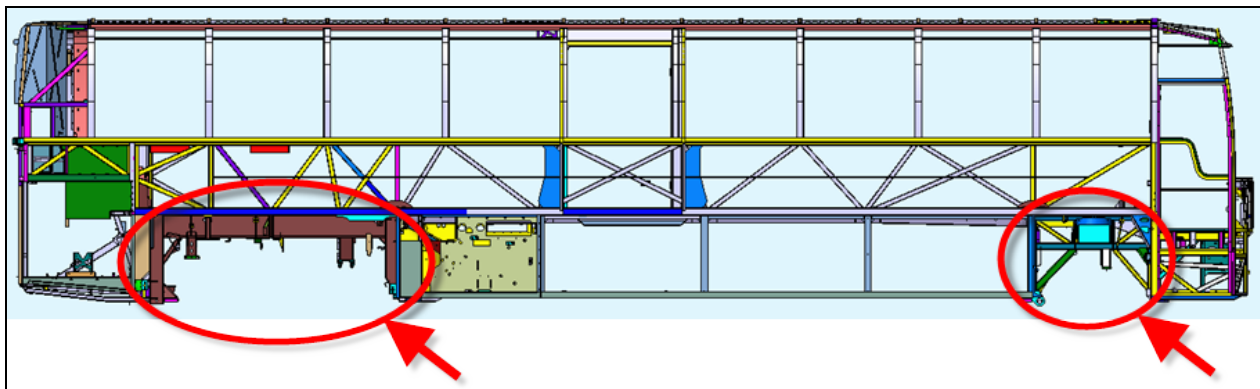

FIGURE 1 – CRITICAL AREAS: FRONT SUB-FRAME, REAR SUB-FRAME, DRIVE AXLE CRADLE AND TAG AXLE

WHEN SHOULD A STRUCTURE INSPECTION BE CARRIED OUT?

Vehicles operating in harsh environments without an appropriate corrosion protection compound applied to the front and rear sub-frames, drive axle cradle and tag axle could be subject to corrosion. If parts of the tag axle or front and rear sub-frames structures present metal flaking, separation of metal layers, loss of material, perforation, etc. then they should be inspected in order to confirm that the minimum wall thickness remains (FIGURE 2 to FIGURE 5).



FIGURE 2: METAL FLAKING. ACCUMULATED SAND AS SHOWN ON THE IMAGE SHOULD NOT BE LEFT IN PLACE



FIGURE 3: METAL FLAKING AND ACCUMULATED SAND



FIGURE 4: METAL FLAKING ON TAG AXLE - ACCUMULATED MATTER WILL RETAIN WATER THUS CREATING CONDITIONS PROMOTING ADDITIONAL CORROSION



FIGURE 5: HEAVILY CORRODED COACH WITH BROKEN TAG AXLE. THIS IMAGE SHOWS THE SPINDLE MOUNTING PLATE SEPARATED FROM THE REST OF THE TAG AXLE

STRUCTURE INSPECTION PROCEDURE

The thickness of main carbon steel parts on rear & front sub-frames, drive axle cradle and tag axle beam must be **at least 1/8 inch (0.125") (3mm)**. There are two options to properly monitor the wall thicknesses:

- 1- Using an ultrasonic wall thickness gauge.
- 2- Drilling holes and measuring wall thickness.

1- Structural Inspection Procedure Using Ultrasonic Wall Thickness Gauge

The ultrasonic wall thickness gauge has to be used on bare metal. The surface where the gauge will be put on has to be cleaned of rust, paint or other material. If the thickness is more than 1/8 inch (3mm), repaint the cleaned surface to prevent corrosion from occurring on this spot.

Use a grinder or another tool to remove rust or paint on the spot to check. The gauge has to be placed on the center of the cleaned spot. The gauge has to be perpendicular to the surface to get an accurate measure.

Inspection using ultrasonic wall thickness gauge is recommended over drilling holes because it minimize risk of altering the vehicle structure.



FIGURE 6: CLEANED SPOT ON STRUCTURAL MEMBER

2- Structural Inspection Procedure Using Drilled Holes

Drill a 1/4 inch (6 mm) diameter hole in the most corroded wall of the part being checked. Use a caliper to measure the thickness of the drilled metal. Wall thickness should be at least 1/8 inch (0.125") (3mm). Drilled hole must then be welded (filled with metal) and repainted after measurement to prevent water infiltration and corrosion from occurring around the hole.

Clean/remove flaking rust on frame. Drill hole in the most corroded wall. The hole must be welded after to prevent corrosion and water infiltration. Filled hole must be painted to prevent corrosion.



CAUTION

Holes and welding can increase the risk of crack initiation. **Ultrasonic wall thickness gauge method is recommended.**



FIGURE 7: HOLE DRILLED IN STRUCTURAL MEMBER

CORROSION PROTECTION ON OLD AND CORRODED FRAME

To maximize corrosion resistance on older frame exposed to harsh environment:

- 1) Clean rust on frame. If available, use sand blasting.
- 2) Apply a zinc-rich primer on cleaned surfaces.
- 3) Cover carbon steel parts with corrosion preventive compound Tectyl 185GW.



CAUTION

Avoid primer, paint, and corrosion preventive compounds on pneumatic valves and rubber bushings.



FIGURE 8: CLEAN RUST

PROTECTION TO PREVENT CORROSION

Tectyl 185GW should be used to prevent corrosion propagation on frame.

- 1) Clean rust and dirt on the frame.
- 2) Apply Tectyl following the manufacturer's recommendation.
- 3) Apply Tectyl every year or as needed.



CAUTION

Avoid primer, paint, and corrosion preventive compounds on pneumatic valves and rubber bushings.



FIGURE 9: TECTYL 185GW BLACK APPLICATION

For more details on Tectyl 185GW, see QC Lubricants web site:

<http://www.qclubricants.com/TECTYL185GWBlack.htm>

Tectyl 185GW Black

QC Lubricants carries Tectyl 185GW Black in pails and drums.

TECTYL® 185GW Black is a solvent cutback, thixotropic corrosion preventive compound. The dry film is semi-firm and has a semi-gloss appearance. TECTYL® 185GW Black provides outstanding protection in marine, tropical, and industrial environments, and is widely used for transportation equipment. TECTYL® 185GW Black possesses dielectric strength of 800 volts per dry mil of coating. TECTYL® 185GW Black provides galvanic corrosion protection and can be applied on battery terminals for insulating purposes.



PARTS / WASTE DISPOSAL

Discard according to applicable environmental regulations (Municipal/State[Prov.]/ Federal)



Access all our Service Bulletins on <https://secureus5.volvo.com/technicalpublications/en/pub.asp>
Or scan the QR-Code with your smart phone.

E-mail us at technicalpublications_prev@volvo.com and type "ADD" in the subject to receive our warranty bulletins
by e-mail.



**MAINTENANCE
INFORMATION**

MI15-41

DATE :	AUGUST 2015	SECTION :	18 - Body
SUBJECT :	CRACKING OF POLYCARBONATE TAILLIGHTS CAUSED BY INAPPROPRIATE CLEANING PRODUCTS		

APPLICATION

Model	VIN	
ALL MODELS		

DESCRIPTION

Prevost would like to remind its customers that only **cleaning products designed for external washing of vehicles** should be used for exterior vehicle wash and in particular, for the washing of polycarbonate taillights.

POLYCARBONATE CRACKING

Degreasers designed to clean motors **must not be used** to clean the engine compartment door. These products are not compatible with polycarbonate. They cause cracking of the polycarbonate taillights housing and cracking of the bosses in which the mounting threaded rods are inserted (figures 2 & 3).

CLEANING PRODUCT COMPATIBLE WITH POLYCARBONATE

Cleaning products designed for external washing of vehicles shall be used to clean your vehicle. Prevost suggests a high PH cleaner compatible with polycarbonate. See the description of the product in the following table

Part No	Description	Qty
686037	EXTERIOR CLEANER (BODY)	1 gallon / 4 liters
686036	EXTERIOR CLEANER (BODY)	5.28 gallons / 20 liters
685841	EXTERIOR CLEANER (BODY)	55 gallons / 210 liters

NOTE
<i>Material can be obtained through regular channels.</i>

High PH cleaning product compatible with polycarbonate - product sheet

Traffic film remover

Will not make plastics crack

Perfect for trucks, cars, trains, buses and machinery. Safe for all types of plastics including polycarbonate. Designed for automatic or pressure washing.

ADVANTAGES	DIRECTIONS	MORE DETAILS
<ul style="list-style-type: none"> - Easily removes traffic film, insects and grease. - Safe for car and truck paint. - Safe for use on metal, rubber, chrome, glass and plastic surfaces. - Does not leave any deposit. - Concentrated. - Eco-friendly. - Easy to rinse. - Dries evenly. 	<p>Pressure washing :</p> <ol style="list-style-type: none"> 1. Use product accordingly to dilution ratio. 2. Spray evenly on vehicle surface starting by the bottom. 3. Rinse thoroughly with cold or lukewarm water. 	<p>Do not wash in direct sunlight. Do not allow product to dry on surface.</p>

DILUTION RATIO

DIRT	RATIO	
Mild	1 oz / 20 oz	50 ml / L
Average	1 oz / 10 oz	100 ml / L
Strong	1 oz / 6.67 oz	150 ml / L

<p>PRECAUTIONS</p> <p>Avoid all contact with eyes. Avoid all contact with skin. Wash hands with soap and water after handling.</p>	<p>FIRST AID</p> <ul style="list-style-type: none"> - Skin: Wash contaminated skin with soap and water. - Eyes: Flush immediately with running water for at least 15 minutes, occasionally lifting the upper and lower eyelids. Seek medical help. - Ingestion: Do not induce vomiting. If the person is conscious, have them drink several glasses of water or milk. Seek medical help.
---	--

PHYSICAL ATTRIBUTE

PHYSICAL STATE:	Liquid
APPEARANCE:	Clear
COLOR:	Transparent
SCENT:	Chemical
PH:	13.1
DENSITY (25°C):	1.1

SECURITY

HEALTH	1
FLAMMABILITY	0
REACTIVITY	0
PERSONAL PROTECTION	B

0 =	NEGLIGIBLE
1 =	LOW
2 =	MODERATE
3 =	HIGHT
4 =	EXTREME

FIGURE 1: PRODUCT SHEET

IMAGES SHOWING THE CRACKING ISSUE

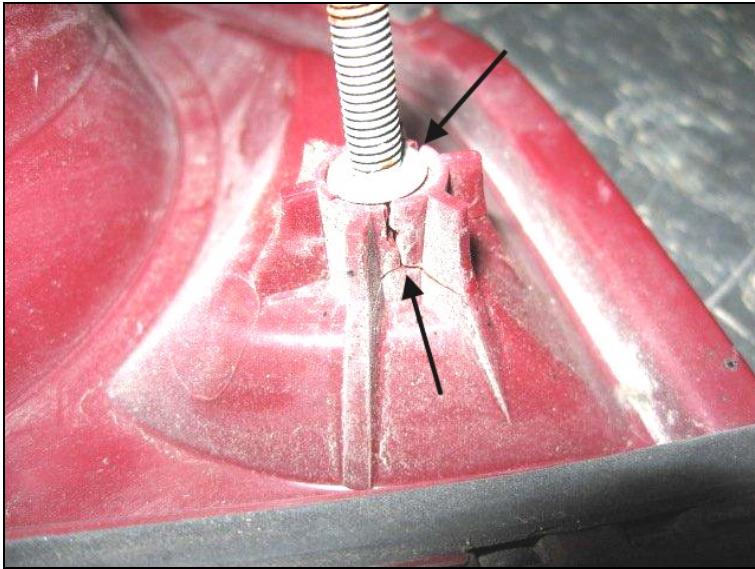

FIGURE 2: Cracks at the boss and ribs due to the use of engine degreaser



FIGURE 3: Cracking of the outer surface of the taillight due to the use of engine degreaser



Access all our Service Bulletins on <https://secureus5.volvo.com/technicalpublications/en/pub.asp>
Or scan the QR-Code with your smart phone.

E-mail us at technicalpublications_prev@volvo.com and type "ADD" in the subject to receive our warranty bulletins by e-mail.



**MAINTENANCE
INFORMATION**

MI15-41

DATE :	AUGUST 2015	SECTION :	18 - Body
SUBJECT :	CRACKING OF POLYCARBONATE TAILLIGHTS CAUSED BY INAPPROPRIATE CLEANING PRODUCTS		

APPLICATION

Model	VIN
 ALL MODELS	

DESCRIPTION

Prevost would like to remind its customers that only **cleaning products designed for external washing of vehicles** should be used for exterior vehicle wash and in particular, for the washing of polycarbonate taillights.

POLYCARBONATE CRACKING

Degreasers designed to clean motors **must not be used** to clean the engine compartment door. These products are not compatible with polycarbonate. They cause cracking of the polycarbonate taillights housing and cracking of the bosses in which the mounting threaded rods are inserted (figures 2 & 3).

CLEANING PRODUCT COMPATIBLE WITH POLYCARBONATE

Cleaning products designed for external washing of vehicles shall be used to clean your vehicle. Prevost suggests a high PH cleaner compatible with polycarbonate. See the description of the product in the following table

Part No	Description	Qty
686037	EXTERIOR CLEANER (BODY)	1 gallon / 4 liters
686036	EXTERIOR CLEANER (BODY)	5.28 gallons / 20 liters
685841	EXTERIOR CLEANER (BODY)	55 gallons / 210 liters

<p>NOTE <i>Material can be obtained through regular channels.</i></p>
--

High PH cleaning product compatible with polycarbonate - product sheet

Traffic film remover

Will not make plastics crack

Perfect for trucks, cars, trains, buses and machinery. Safe for all types of plastics including polycarbonate. Designed for automatic or pressure washing.

ADVANTAGES	DIRECTIONS	MORE DETAILS
<ul style="list-style-type: none"> - Easily removes traffic film, insects and grease. - Safe for car and truck paint. - Safe for use on metal, rubber, chrome, glass and plastic surfaces. - Does not leave any deposit. - Concentrated. - Eco-friendly. - Easy to rinse. - Dries evenly. 	<p>Pressure washing :</p> <ol style="list-style-type: none"> 1. Use product accordingly to dilution ratio. 2. Spray evenly on vehicle surface starting by the bottom. 3. Rinse thoroughly with cold or lukewarm water. 	<p>Do not wash in direct sunlight. Do not allow product to dry on surface.</p>

DILUTION RATIO

DIRT	RATIO	
Mild	1 oz / 20 oz	50 ml / L
Average	1 oz / 10 oz	100 ml / L
Strong	1 oz / 6.67 oz	150 ml / L

PRECAUTIONS	FIRST AID
<p>Avoid all contact with eyes. Avoid all contact with skin. Wash hands with soap and water after handling.</p>	<ul style="list-style-type: none"> - Skin: Wash contaminated skin with soap and water. - Eyes: Flush immediately with running water for at least 15 minutes, occasionally lifting the upper and lower eyelids. Seek medical help. - Ingestion: Do not induce vomiting. If the person is conscious, have them drink several glasses of water or milk. Seek medical help.

PHYSICAL ATTRIBUTE

PHYSICAL STATE:	Liquid
APPEARANCE:	Clear
COLOR:	Transparent
SCENT:	Chemical
PH:	13.1
DENSITY (25°C):	1.1

SECURITY

HEALTH	1
FLAMMABILITY	0
REACTIVITY	0
PERSONAL PROTECTION	B

0 =	NEGLIGIBLE
1 =	LOW
2 =	MODERATE
3 =	HIGHT
4 =	EXTREME

FIGURE 1: PRODUCT SHEET

IMAGES SHOWING THE CRACKING ISSUE

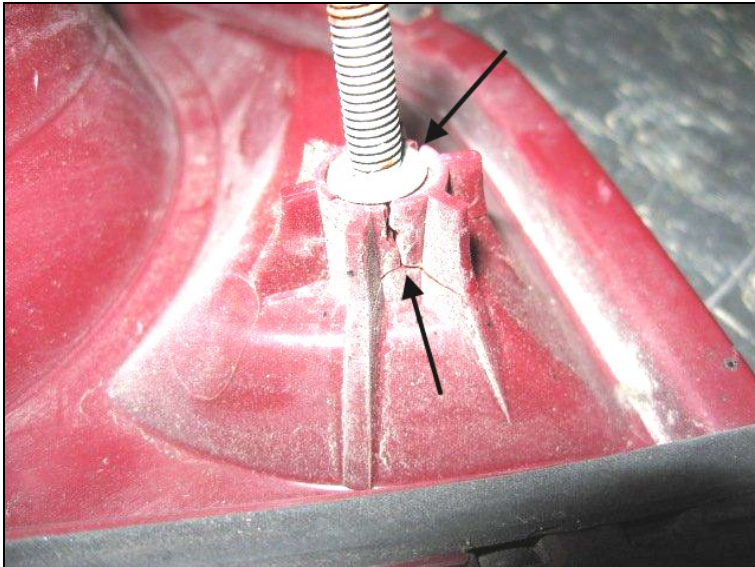

FIGURE 2: Cracks at the boss and ribs due to the use of engine degreaser



FIGURE 3: Cracking of the outer surface of the taillight due to the use of engine degreaser



Access all our Service Bulletins on <https://secureus5.volvo.com/technicalpublications/en/pub.asp>
Or scan the QR-Code with your smart phone.

E-mail us at technicalpublications_prev@volvo.com and type "ADD" in the subject to receive our warranty bulletins by e-mail.

