

PREVOST

Instruction Sheet

IS-12010

LEFT BELL CRANK REPLACEMENT

APPLICATION

Model	VIN 
H3-45 coaches Model Year : 2009 - 2013	From 2PCH33494 <u>9</u> C71 <u>1386</u> up to 2PCH33494 <u>D</u> C71 <u>2272</u> incl.
X3-45 coaches Model Year : 2007 - 2013	From 2PCG33494 <u>7</u> 102 <u>8754</u> up to 2PCG33493 <u>D</u> C73 <u>5392</u> incl.
H3-45 VIP motorhomes Model Year : 2004 - 2012	From 2PCV33494 <u>4</u> 101 <u>4758</u> up to 2PCVS3493 <u>C</u> C71 <u>1943</u> incl.
X3-45 VIP Entertainer Model Year : 2004 - 2013	From 2PCY33497 <u>4</u> 102 <u>8165</u> up to 2PCYS3497 <u>D</u> C73 <u>5385</u> incl.
XL2 motorhomes Model Year : 2004 - 2011	From 2PCW33403 <u>4</u> 102 <u>8169</u> up to 2PCW33496 <u>B</u> C72 <u>9997</u> incl.
XL2 coaches Model Year : 2004 - 2006	From 2PCX33493 <u>4</u> 102 <u>8112</u> up to 2PCX33493 <u>6</u> 102 <u>8906</u> incl.

MATERIAL

Order kit 161349 that contains the following parts:

Part No.	Description	Qty
160115	SLEEVE WIPER	1
161338	FLAT WASHER	1
501490	GREASE FITTING 1/8" NPT	1
507353	CUP AND CONE-BEARING KIT	1
507672	ROLL BEARING, 60X95X23	1
507673	V SEAL 88-93 ID X 6 WALL X 8.9 FIT	1
507674	OIL SEAL 100 OD X 77.2 ID X 6.4	1
661185	LEFT BELL CRANK	1
661186	SPINDLE SHAFT	1
661202	DRAG LINK ROD END, L.H. THREAD	1
5001844	NUT HEXF SERR G500 M16-2.0	4
5001859	CAP SCREW HEXF SERR G500 M16-2.0X50 CL10.9	4
5001218	NUT HEX CSL M30-1.5	1
FI-12010	FEUILLE D'INSTRUCTION	1
IS-12010	INSTRUCTION SHEET	1

Other parts that may be required:

Part No.	Description	Qty
661014	CAP	1
502104	PIN COTTER 5/32 X 2 ZP	2
502109	PIN COTTER Z050 6.3X71MM	1
502115	PIN COTTER 3/16X2 1/2 ZP	1

PROCEDURE



DANGER

Park vehicle safely, apply parking brake, stop the engine. Prior to working on the vehicle, set the ignition switch to the OFF position and trip the main circuit breakers equipped with a trip button. On Commuter type vehicles, set the battery master switch (master cut-out) to the OFF position.

EXISTING BELL CRANK REMOVAL

1. Disconnect drag link, tie rod and relay rod from the bell crank by removing cotter pins and nuts from ball studs.

NOTE

Use a piece of wire to support loosen end of relay rod and tie rod in order to prevent placing an excessive load on opposite socket end.

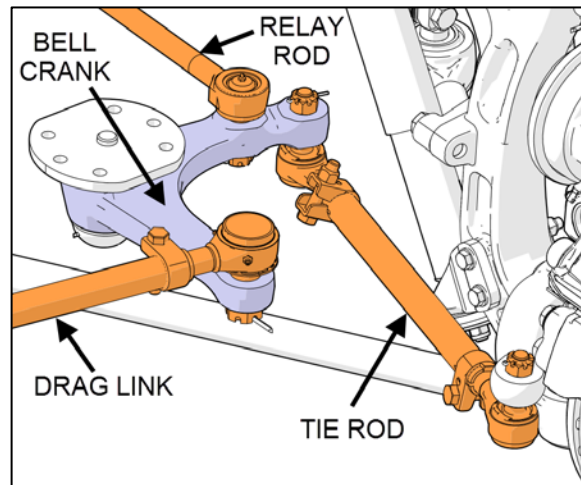

FIGURE 1

2. Remove nuts from bolts attaching bell crank mounting spindle to vehicle frame.
3. Discard all parts, but keep shims if applied.

NOTE

If the current installation has shims, keep these shims for the future installation of the new bell crank. With a permanent marker, add marks on shims to reinstall them back at the exact same position.

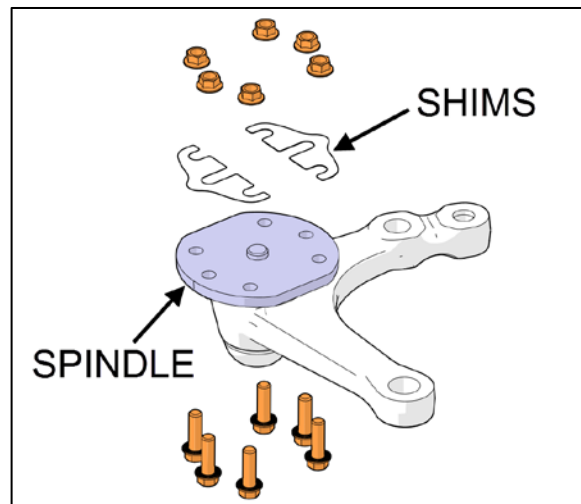

FIGURE 2

NEW BELL CRANK INSTALLATION

NOTE

For bearing installation, use tool Prevost part # 110684.

NOTE

Grease must be able to exit the bell crank mechanism.
For grease retainer installation, use tool Prevost # 110683.

NOTE

Apply grease on bearings before installation.

4. Install new grease fitting on the new bell crank.

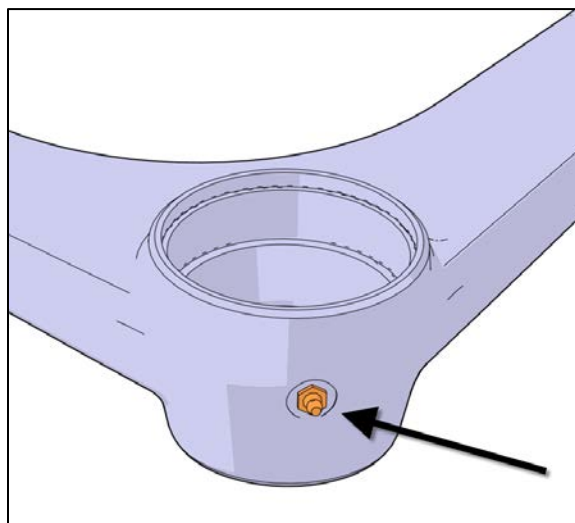

FIGURE 3

5. Clean parts thoroughly with degreaser.
6. Insert the small bearing outer race into the appropriate bore (done on a press).
7. Insert the large bearing outer race into the appropriate bore (done by press).

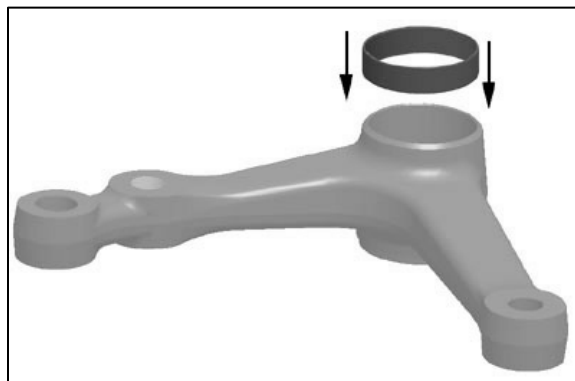

FIGURE 4

8. Insert the large bearing into outer race and then, add the grease retainer.



FIGURE 5

9. Apply good quality lithium grease (#60752) on backup ring and dust boot.
10. Install backup ring and dust boot on the bell crank spindle.
11. Apply a thin layer of grease on the spindle shaft.

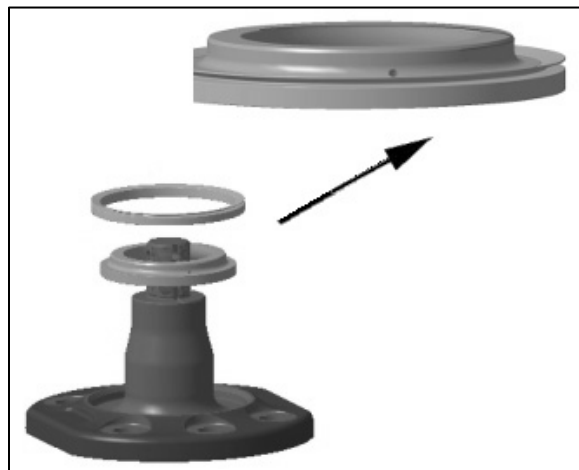

FIGURE 6

12. Install bell crank onto its mounting spindle, while holding the bell crank, slide on the small bearing assembly.

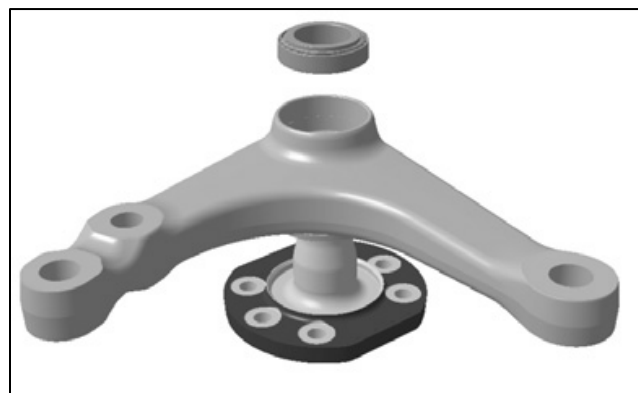

FIGURE 7

13. Install thrust washer and nut.



FIGURE 8

14. Tighten nut to 130 lb-ft.

15. Rotate three turns in each direction.

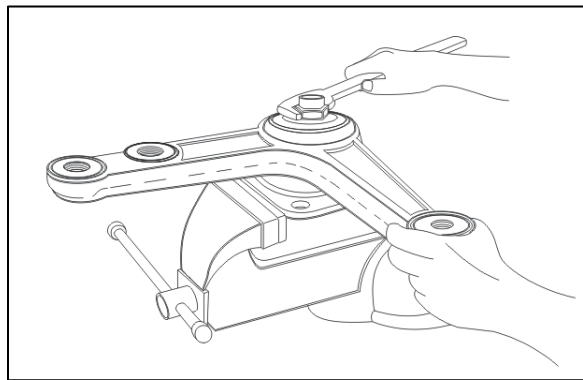

FIGURE 9

16. If necessary, unscrew nut until bell crank starts to turn with the application of 1 to 3 lbs force load as shown on Figure 10.

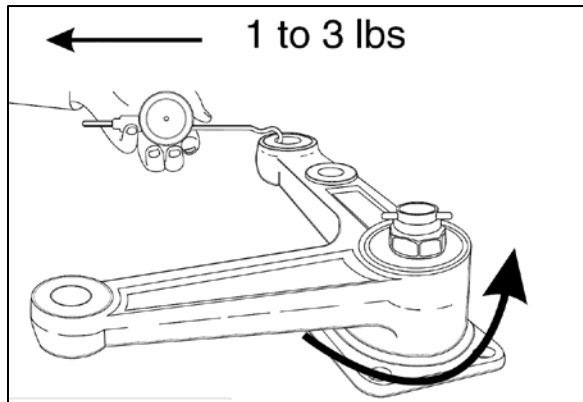

FIGURE 10

17. Check the play between parts A, B, C and D.

NOTE

Nut must be tightened without any axial play between parts A, B, C and D.

18. Check for loose bearings by applying an up and down load on bell crank. The lever is not supposed to move in the vertical axis direction

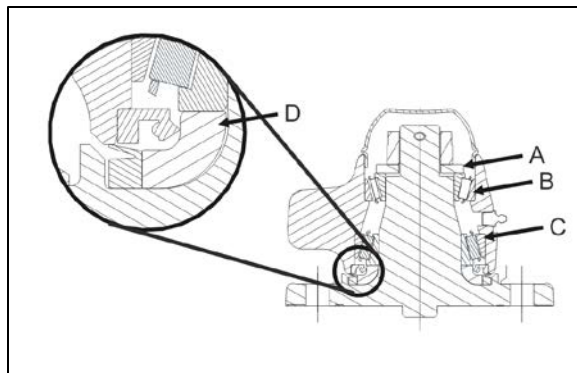

FIGURE 11

19. If necessary, loosen nut slightly to allow the insertion of cotter pin.

20. Install new cotter pin #502115.

21. Bend cotter pin around the nut.

22. Install cap.

23. Using degreaser, clean shims and mating surfaces prior installing new bell crank on the vehicle structure.

24. Install new bell crank on the vehicle structure using six new screws and six new nuts.

25. Tighten all nuts between 208 and 254 lb-ft.

26. Check drag link end, tie rod end and relay rod end. If sign of wearing appears, replace it.

NOTE

Do not bend the cotter pin in the direction of the cap as it may interfere with it.

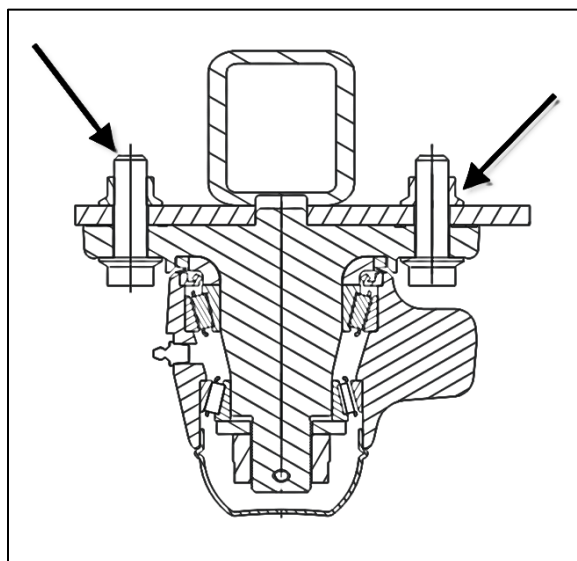

FIGURE 12

27. Measure the distance between the center lines of both existing rod ends of the drag link and write it on paper.

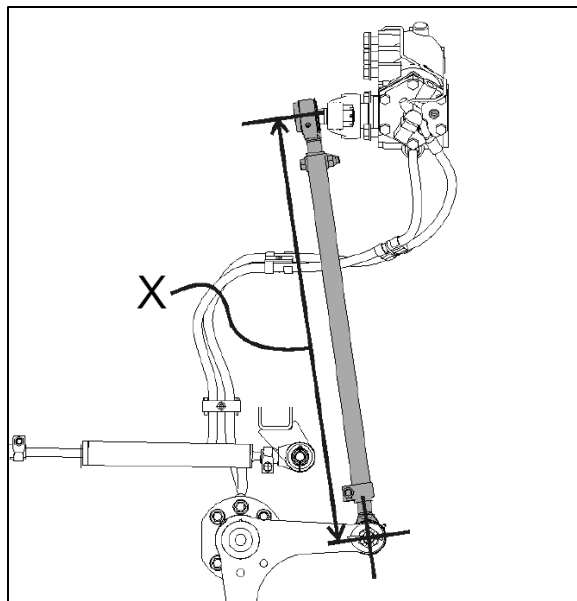

FIGURE 13

28. Disconnect the existing rod end of the drag link that connects to the bell crank. Keep fasteners and collar. Discard the rod end.
29. Install the new rod end #661202 on the drag link rod using the existing fastener and collar.
30. Adjust the distance between the center lines of the rod end using the measurement in step 27.
31. Tighten the nut between 50 to 60 lb-ft.

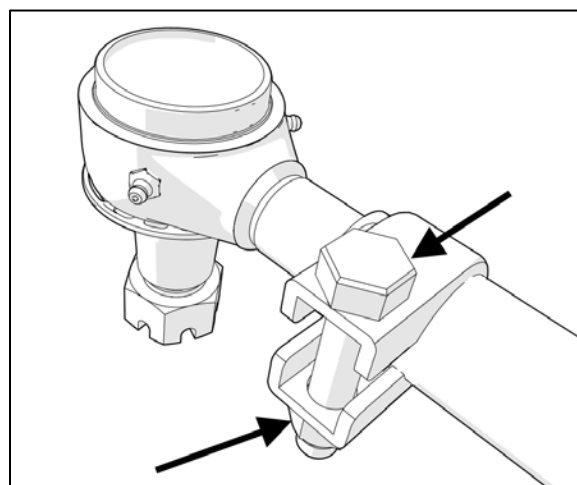

FIGURE 14

32. Install drag link stud with the locking nut.
33. Tighten nut between 245 and 270 lb-ft.
34. Install new cotter pin #502109.

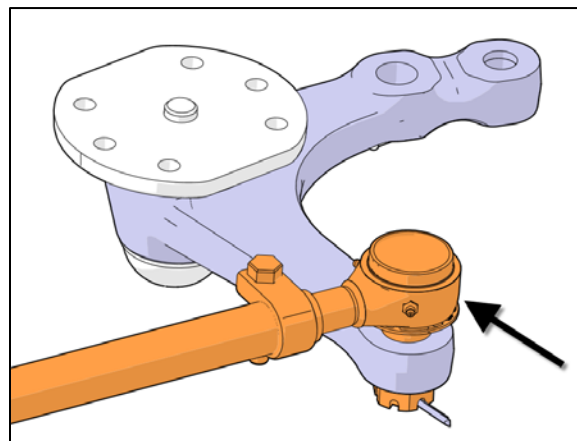

FIGURE 15

35. Install tie rod stud with the locking nut.
36. Tighten nut between 150 and 200 lb-ft.
37. Install new cotter pin #502104.

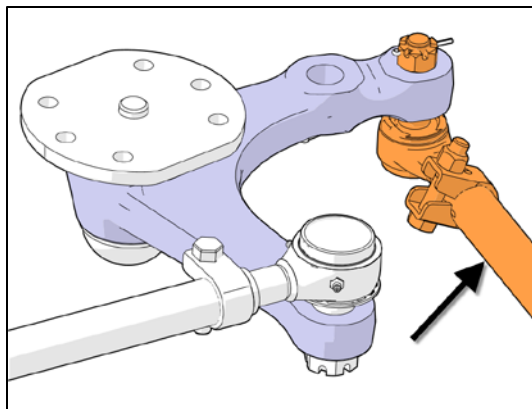

FIGURE 16

38. Install relay rod stud with the locking nut.
39. Tighten nut between 150 and 200 lb-ft.

NOTE

Tighten nut to specified torque, then advance to next aligning cotter pin slot.

40. Install new cotter pin #502104.

NOTE

Remove pieces of wire that supported loosen end of relay rod and tie rod.

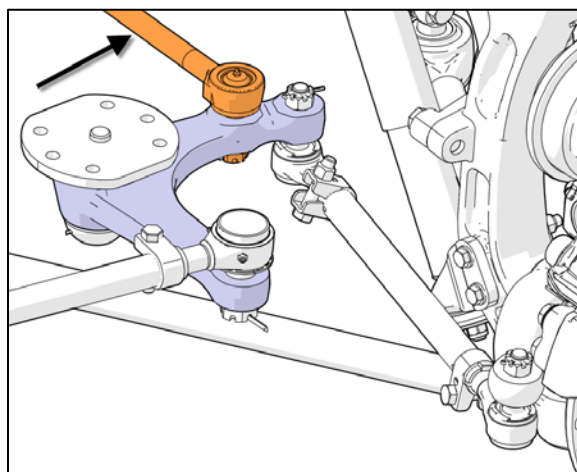

FIGURE 17

41. Adjust turning angle as previously directed under paragraph "**Turning Angle**" into section 10 of the maintenance manual.
42. Check front wheel alignment as specified into section 10 of the maintenance manual.
43. Bulletin is complete.

ESTIMATED TIME

The time required to perform this special bulletin is approximately six hours. Add two hours if wheel alignment is necessary.

PARTS / WASTE DISPOSAL

Discard waste according to applicable environmental regulations (Municipal/State[Prov.]/ Federal)