

PREVOST

Instruction Sheet

IS-94099

REPLACEMENT OF ALLISON TRANSMISSION HARNESS

**#063539 (XL SERIES), #063953 (XL SERIES),
#063561 (H3 SERIES), #063854 (H3 SERIES)**

MATERIAL

Kit #065892 includes the following parts:

Part No.	Description	Qty
064239	Vehicle harness	1
064237	Transmission harness	1
562425	Packard 24-circuit connector	1
562352	Crimp-type terminal	25
562032	Sealing plug	5
IS-94099	Instruction Sheet	1
FI-94099	Feuille d'instructions	1

Kit #065919 includes the following parts:

Part No.	Description	Qty
064238	Vehicle harness	1
064237	Transmission harness	1
562425	Packard 24-circuit connector	1
562352	Crimp-type terminal	25
562032	Sealing plug	5
IS-94099	Instruction Sheet	1
FI-94099	Feuille d'instructions	1

PROCEDURE

Warning : Park vehicle safely, apply parking brake, stop engine and set battery master switch(es) to the OFF position prior to working on the vehicle.

Note : Place the transmission ECU circuit breaker to the "OFF" position before unplugging any connectors from the ECU.

1. Disconnect all the existing transmission harness connectors which are located on the transmission casing (XL+H3) and also the connectors located inside the rear electrical compartment (H3) and inside the front service compartment (XL+H3) at the other end of the transmission harness (see figure 2 & 3 as reference).

2. Plug the transmission harness (#064237) connectors (figure 1) as shown in figure 2. For vehicles not equipped with a transmission retarder, secure the retarder related connectors on the harness using nylon ties.
3. Route #064239 (XL) harness between engine compartment and front service compartment. Route #064238 (H3) harness between engine compartment and rear electrical compartment using the rubber wireway then route the harness to the front service compartment using the cable duct between rear electrical compartment and front service compartment (figure 6).
4. Inside engine compartment, plug connector C463 to C463 of #064237 harness and fix the harness using nylon ties. Plug connector C456 to transmission retarder accumulator (figure 2 & 3). Plug connector C457 to transmission main connector C457. Transmission main connector may be located in two different places depending if it is a rectangular type (Packard) or circular type (see figure 2 for location of the main connector).

Note : *If the transmission main connector is a rectangular type, it is necessary to replace the circular type connector C457 of #064238 or #064239 harness with #562425 Packard connector included in the kit. To do so, perform the following steps.*

- a) *Open C457 connector of harness #064239 (XL) or #064238 (H3) and pull out the wires.*
- b) *Insert the wires through #562425 Packard 24-circuit connector using the following table for wire identification and location:*

WIRE OR CIRCUIT NUMBER	CONNECTOR POSITION CODE
102	A2
103	C1
104	F1
106	G3
107	D3
110	D2
120	A1
121	B2
126	A3
128	B1
129	E1
130	C2
131	D1
135B	G2
140	E2
147	F3
149	E3
161A	F2
162	C3
165	B3

- c) *After having inserted the wires, remove 3/16" of isolating sleeve and crimp a #562532 terminal onto each wire (figure 4). If it is necessary to cut the end of wires, make sure that the wire or circuit number is still visible on the wires.*
- d) *Once crimping is completed, pull each wire back in order to seat the terminal into its receptacle. A click can be heard when the terminal is properly seated. Place a sealing plug in the remaining ports.*
- e) *Plug the Packard connector to transmission rectangular feed-thru connector on the transmission casing.*

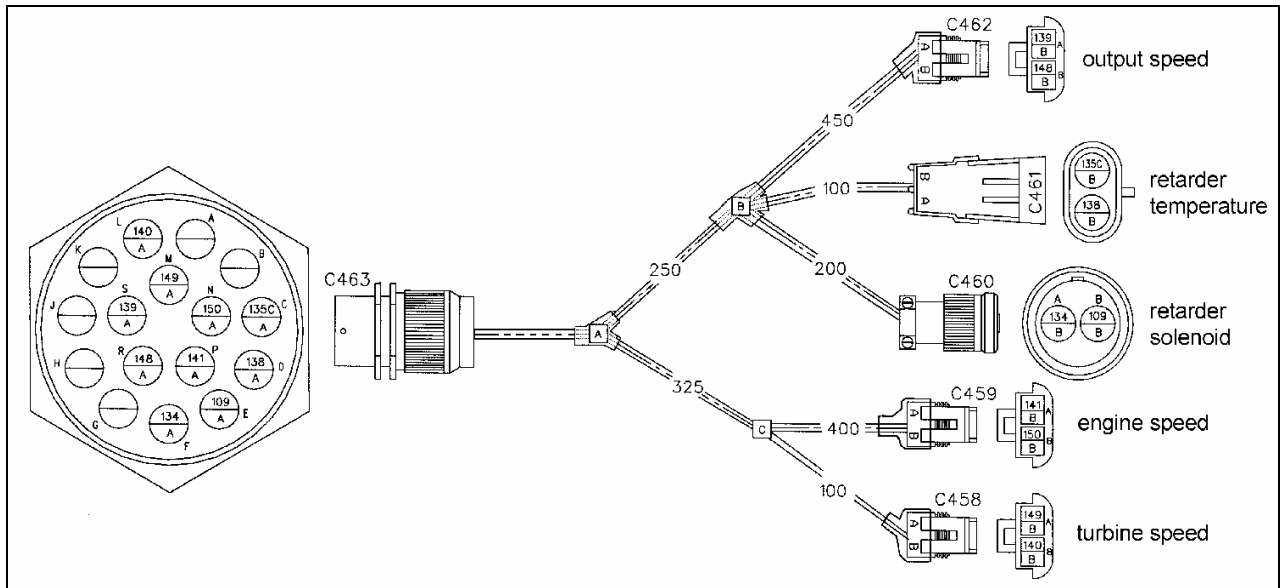

FIGURE 1: #064237 transmission harness

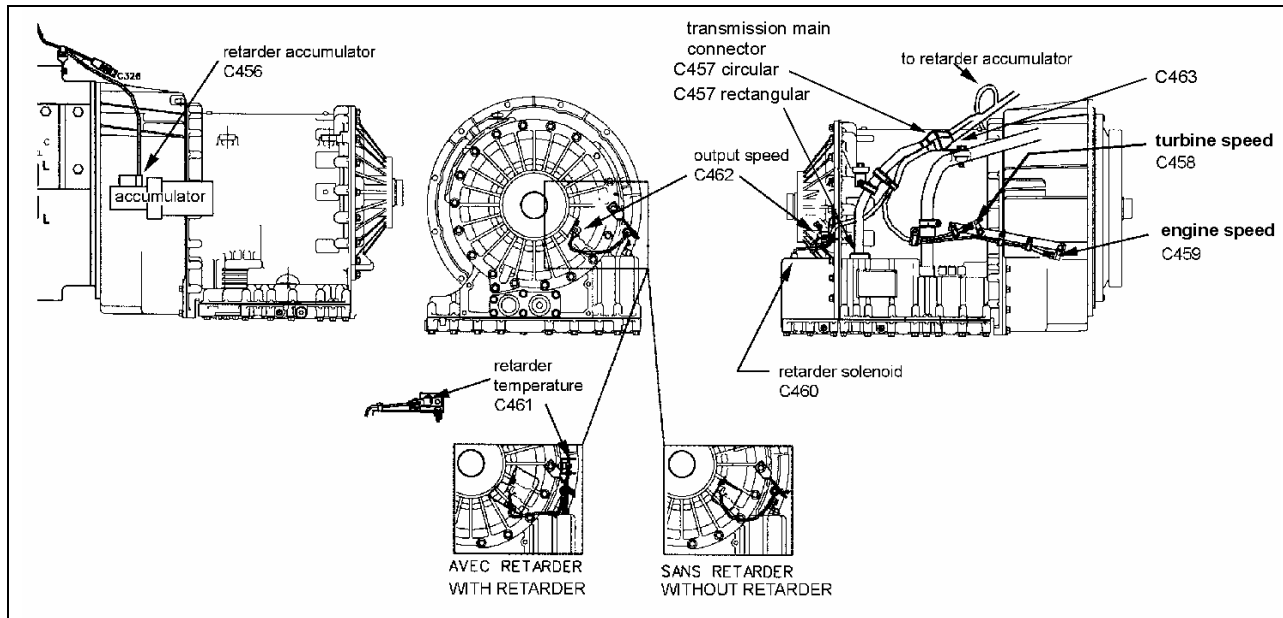

FIGURE 2: Harness #064237 (XL+H3), #064238 (H3) & #064239 (XL) connection location

5. **XL SERIES ONLY.** Inside front service compartment, plug connectors CA & CB to ECU (Electronic Control Unit). Plug connector C468 to VIM (Vehicle Interface Module). Plug connector C169 to VIW (Vehicle Interface Wiring). Plug connector C465 to transmission shift selector control pad connector under lateral control panel. Plug connector C466 to transmission retarder resistance module and C467 to transmission retarder hand lever resistance module. Both resistor modules are fixed under the driver's area floor. Connector C464 is used to connect with "Pro-Link" diagnostic tool. Secure this connector using nylon ties.
6. **H3 SERIES ONLY.** Inside rear electrical compartment, plug connectors CA & CB to ECU (Electronic Control Unit). Plug connector C468 to VIM (Vehicle Interface Module). Plug connector C182 to VIW (Vehicle Interface Wiring). Connector C464 is used to connect with "Pro-Link" diagnostic tool. Secure this connector using nylon ties (figure 5).

7. **H3 SERIES ONLY.** Inside front service compartment, plug connector C465 to transmission shift selector control pad connector under lateral control panel. Plug connector C465 to transmission shift selector control pad connector under lateral control panel. Plug connector C466 to transmission retarder resistance module and C467 to transmission retarder hand lever resistance module.

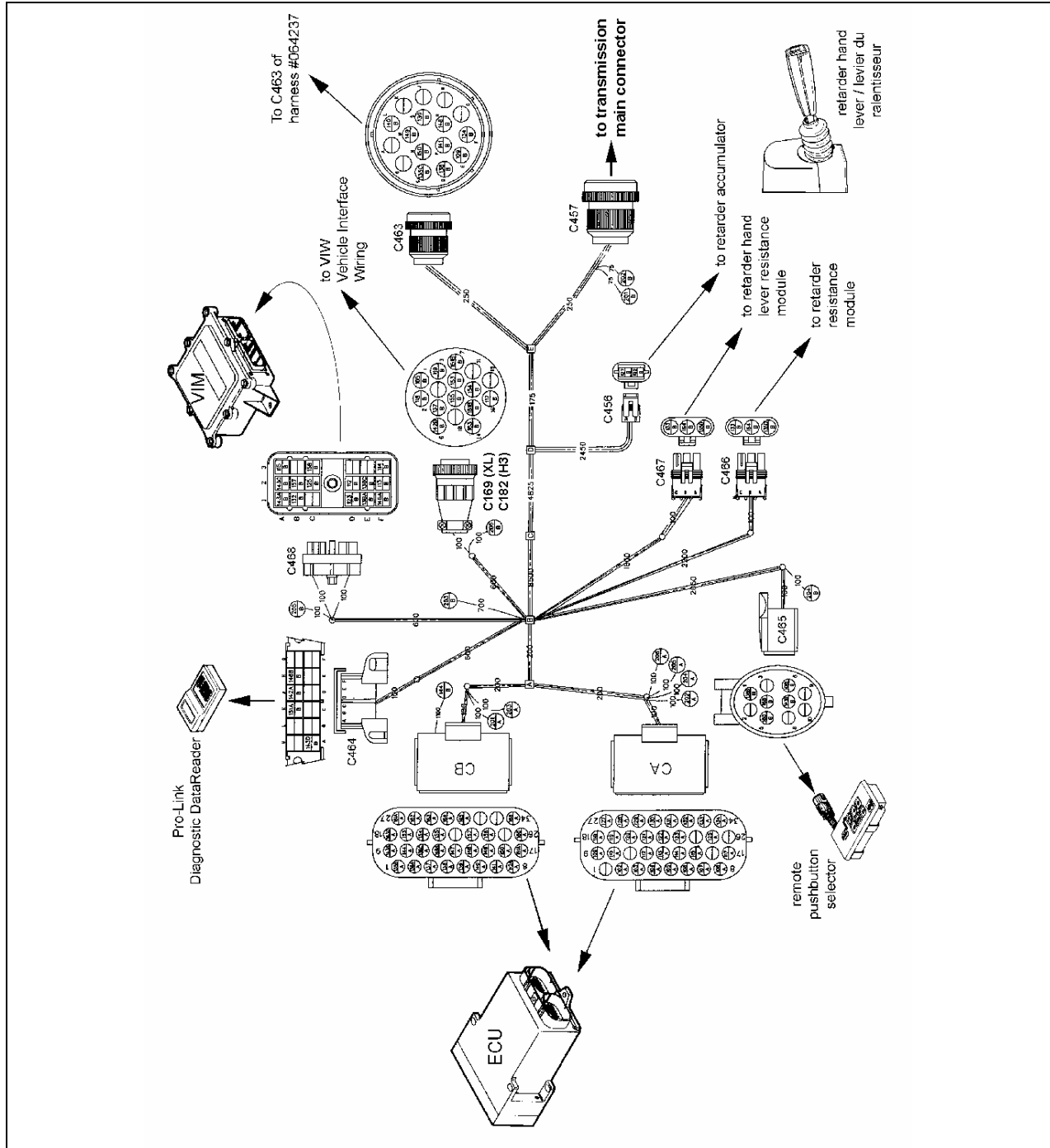

FIGURE 3: #064238 (H3) or #064239 (XL) vehicle harness

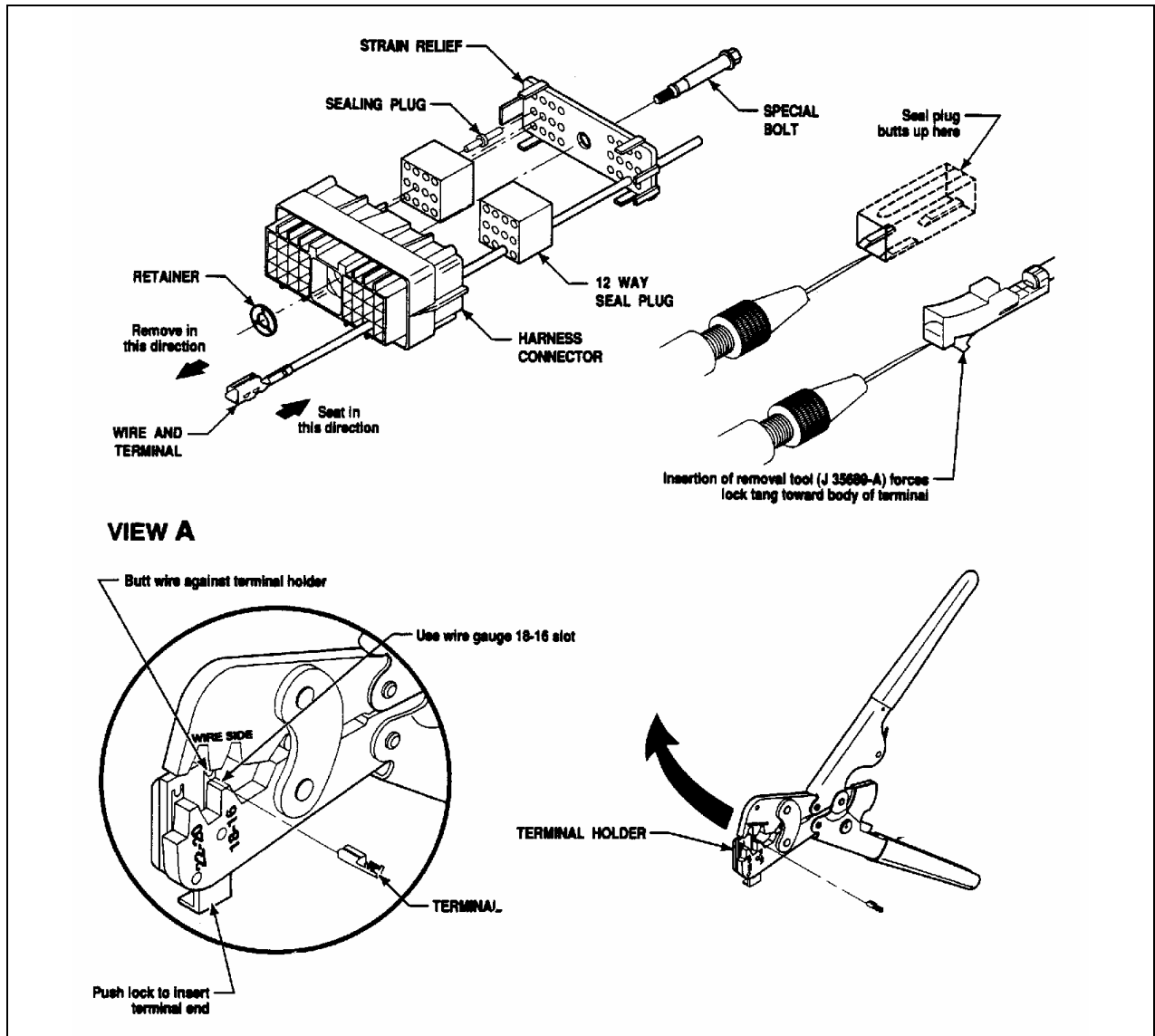

FIGURE 4: Packard connector preparation

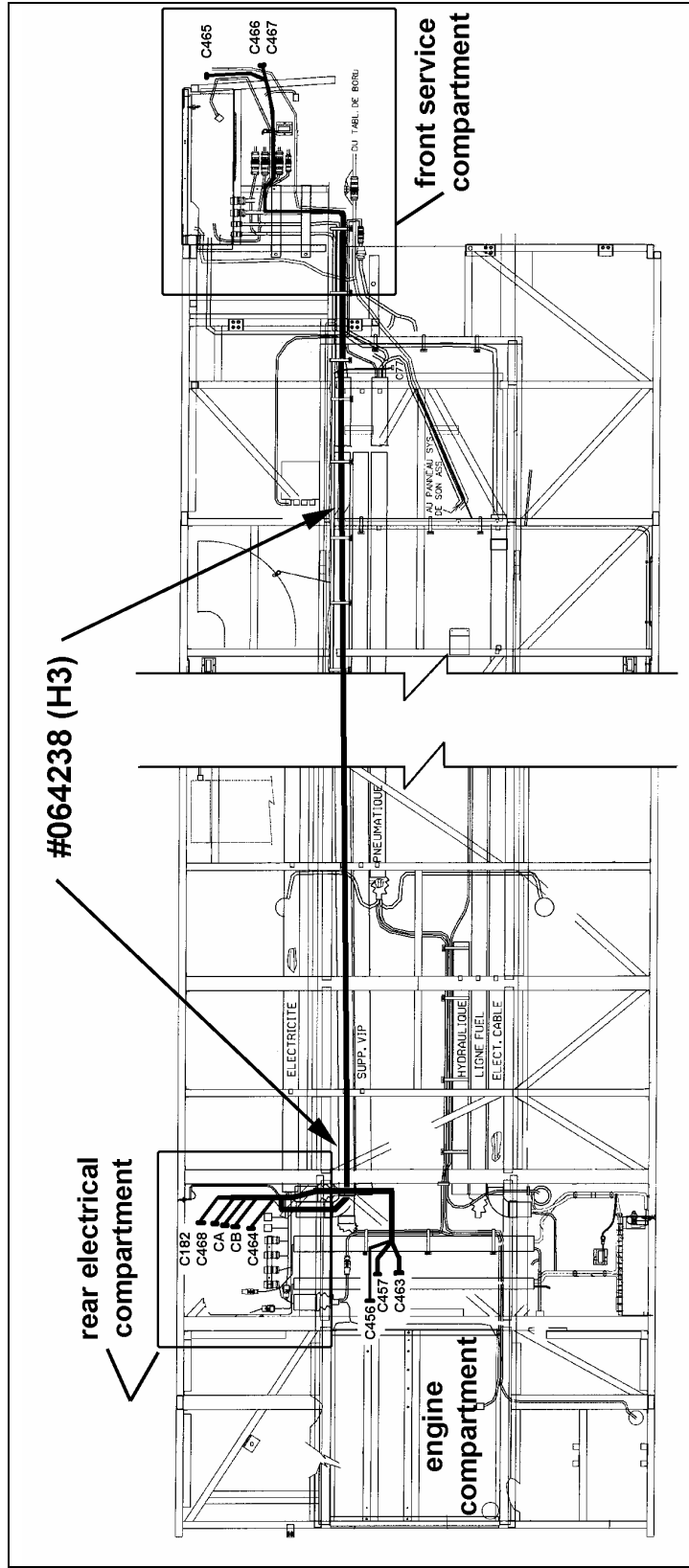

FIGURE 5:#064238 (H3) harness routing