

PREVOST

Instruction Sheet

IS-21089





EFD H3 VIP CONDENSER REPOSITIONING





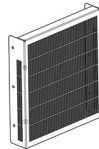
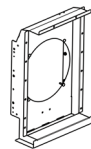
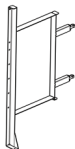

First Release

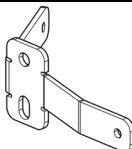
06-13-2023





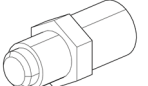
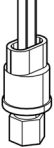
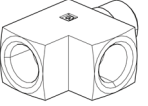
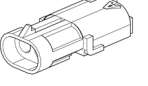
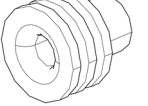
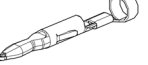
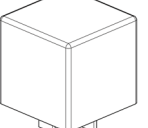

MATERIAL

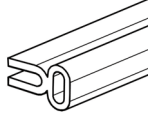
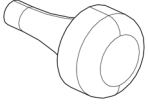
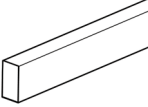
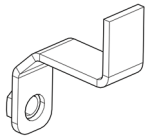
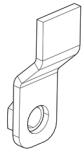
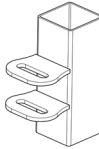
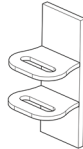
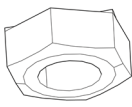
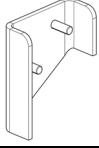
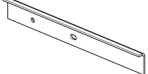
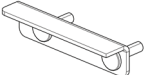

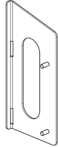
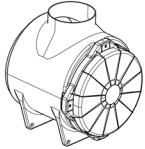
Kit #IS21089 includes the following parts:

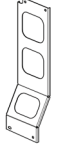
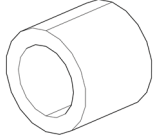

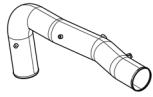
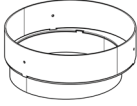
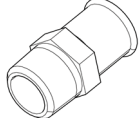
Part No	Description		Qty
950552	CONDENSER		1
565881	FAN CONDENSOR 12" - BRUSHLESS - AXIAL		1
454036	PROTECTIVE PANEL		1
454037	SHROUD ASSY.		1
454864	CONDENSER BRACKET ASSY.		1
454888	BRACKET, AIR DRYER		1
454892	TOP BRACKET		1
454893	BRACKET		1

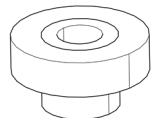
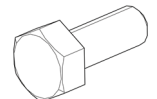
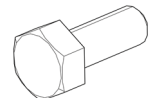
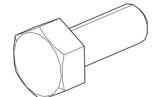
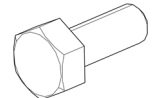
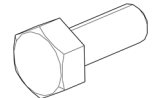
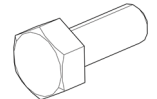
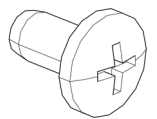
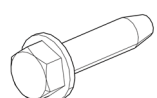
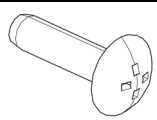
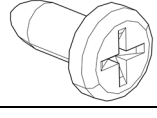

454032	HOSE, CONDENSER 3180MM LG ASSY		1
454031	HOSE, CONSENSER 2570MM LG, ASSY		1
454030	HOSE ASSY 1550MM LG		1
455031	HOSE, REFRIGERANT 3700MM LG ASSY		1
950370	FILTRE DRYER		1
950249	VALVE		1
950270	PRESSURE SWITCH		1
501338	TEE 1/4PM x 1/4PF x 1/4PF		1
561566	CONNECTOR PED W-PACK 2 PH		1
561565	WIRE SEAL PED W-PACK 20-16 GRN		2
561567	TERMINAL PED WEATHER-P PIN 20-18AWG		2
563332	MINI RELAY, 24V WITH RESISTOR		2
562101	TERMINAL PED METRI-P 280 SOCKET 16-14AWG		1
0610379	HARNESS, DRIVER AIR CONDENSER X3		1

2810653	PANEL, PERFORATED, COMPRESSOR DOOR VIP		1
506302	RUB EXTRUSION EPDM BLACK		7 ft
504709	RUBBER BUMPER 9/32X1 1/16 X 5/8 X 1/16		2
506228	TAPE AD1 PE CC BK 1/4"X1/2"X37.5'		6.5ft
218982	ANGULAR WELDED ASSY.		1
218942	ANGULAR WELDED ASSY.		1
2810648	BRACKET, CONDENSER HINGE ASSY.		2
2810658	BRACKET UP, CONDENSER HINGE ASSY.		1
502609	NUT WD HEX SS M8-1.25		1
218948	BRACKET, AIR DRYER		1
218944	BRACKET, AIR FILTER		1
218943	BRACKET, INTAKE TUBE		1

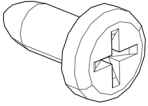
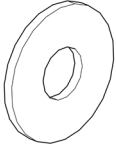
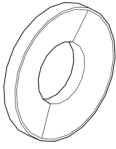
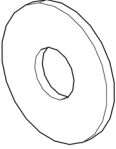
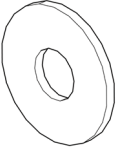
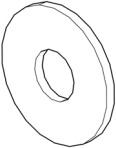
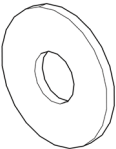
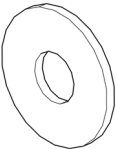
218949	BRACKET, OIL TANK		1
531493	AIR CLEANER, ENGINE		1
531363	REDUCER 7 TO 5 IN, ENGINE		1
030292	BRACKET REAR, AIR FILTER		1
030293	BRACKET FRONT, AIR FILTER		1
032540	SPACER		1
032541	BRACKET		1
030053	AIR INTAKE PIPE, ENGINE		1
030232	ADAPTER ASSY.		1
5011240	ADAPTER ST 3/4 PM X 1"		1
030286	HOSE 7" DIA. 270MM LG.		1
030291	HOSE 1016MM LG.		1

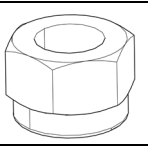
030045	DECAL, S4 MOT PREHEATER F		1
030046	DECAL, S4 MOT PREHEATER E		1
034005	DECAL, M4 MOT TORQUE FE		1
286716	SPACER		4
5001981	SCREW CAP HEX SS NSS M8X50		2
502862	SCREW CAP HEX N500 M8-1.25X20 G8.8		8
502836	SCREW CAP HEX N500 M8-1.25X35 G8.8 FT		4
5001990	SCREW CAP HEX NYL BK M8X1.25X30		4
5001697	SCREW CAP HEX SS NSS M6X16		6
502780	SCREW CAP HEX SS NSS M8X25		4
5001975	SCREW TC BDG PH SS410 Z050 10-24X3/8		14
500266	SCREW TC HEXW N500 1/4-20X1		3
500283	SCREW TC TR PH SS410 10-24X3/4		12
502868	SCREW TC TR PH N500 #10-16 X 1/2		2

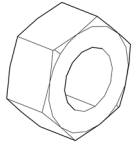
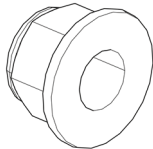
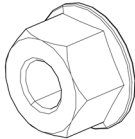
509805	SCREW TP PAN PH N050 #10X1/2		6
5001833	WASHER BEL SPR SS 301 6.65X17.4X1.27		4
5001868	WASHER BEL SS 8.4X18X2		4
500332	WASHER FL N500 .328X.875X.062		12
5001736	WASHER FL N500 8.4X18X2		10
5001137	WASHER FL SS .203X.438X.06		14
500411	WASHER FL SS .260X.697X.05		6
5001849	WASHER FL SS 8.4X24X2		4
502853	WASHER LO SPT N500 6.1X11.8X1.6		6
500942	WASHER LO SPT N500 8.1X14.8X2		8
5001787	NUT HEX NYRT SS M8-1.25X9.5		2

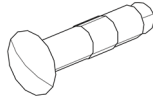
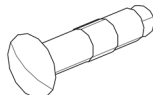
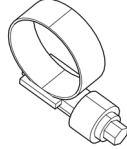
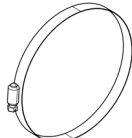
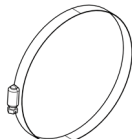
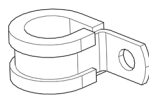
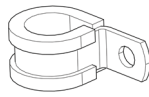
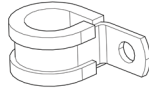
5001851	NUT HEX SS NSS M6-1.0		4
5001931	NUT HEXF NYRT NX500 M8-1.25 CP 8		6
502692	NUT HEXF STO Z050 M8-1.25EX		4
502837	NUT HEXF STO N500 M8-1.25		2
504339	RIVET POP DOME SS OE 1/8 (0.25_0.375)		3
504379	RIVET POP DOME SS OE 3/16 (0.126_0.250)		2
504291	CLAMP HOSE LINER SS/CS 21-44		2
504324	CLAMP HOSE SS/CS 114-165		1
504229	CLAMP HOSE SS/CS 165-216		3
952627	CLAMP P STL ZP RUB 12.7 ID		1
952629	CLAMP P STL ZP RUB 15.9 ID		3
952631	CLAMP P STL ZP RUB 19 ID		1

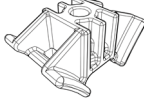
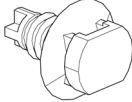
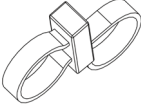
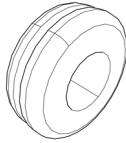
504013	CABLE TIE MOUNT, BLACK 1/4"		2
509490	TWO WAY SADDLE MOUNTS, GREY		1
509815	FIR TREE MOUNTING (FT7 TYPE)		2
504016	CABLE TIE, NYLON BLK (LIGHT-HEAVY)		20
504637	CABLE TIE, NYLON BLK (STD)		40
504768	CABLE TIE, NYLON BLK DOUBLE LOOP		15
504061	GROMMET .4375X.6875X.0625X.3125X.9375		1
IS-21089	INSTRUCTION SHEET (EN)		1

<i>NOTE</i>
<i>Material can be obtained through regular channels.</i>

SAFETY PRECAUTIONS

- Eye protection should always be worn when working in a shop.
- Rules for Personal Protection Equipment should always be respected. Wear your PPE including but not limited to the following:



Safety First!



PROCEDURE



DANGER

Park vehicle safely, apply parking brake, stop engine. Prior to working on the vehicle, set the ignition switch to the OFF position and trip the main circuit breakers equipped with a trip button. On Commuter type vehicles, set the battery master switch (master cut-out) to the OFF position.

Lock out & Tag out (LOTO) must be performed during set-up, maintenance or repair activities. Refer to your local procedure for detailed information regarding the control of hazardous energy.

NOTE

Be aware before to start the project you must remove and relocate all converter appliance inside compartment (ex.: heater, pressure washer... etc.)

Table of contents

A. PART TO REMOVE	11
B. PART TO WELD	15
C. AIR FILTER INSTALLATION.....	31
D. COMPRESSOR DOOR MODIFICATION	38
E. CONDENSER INSTALLATION	39
F. DRYER INSTALLATION.....	44
G. HOSE INSTALLATION.....	46
H. HOSE FIXATION.....	48
I. POWER STEERING TANK INSTALLATION.....	51
J. WIRING HARNESS INSTALLATION	52
K. VPG: PARAMETER SETTING	55
Appendix A.....	56

A. PART TO REMOVE

1. Remove all appliances in the compartment, all those systems need to be relocated in the vehicle.

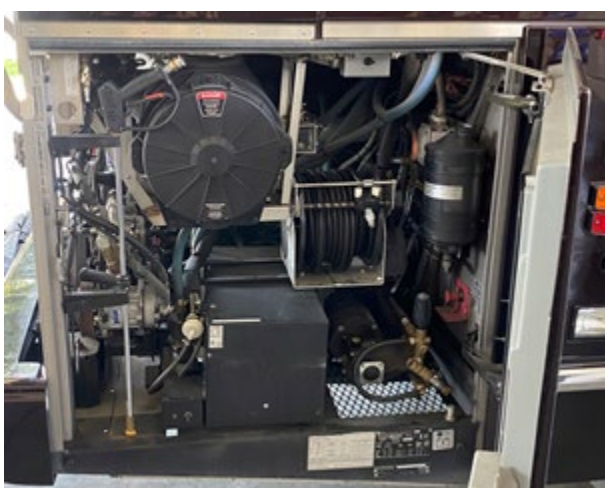

2. Remove air filter installation.

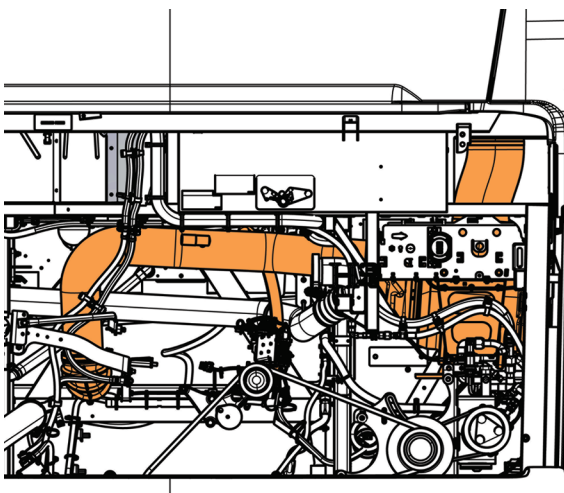

3. Reuse those parts from the old turbo pipe connection:

- Inlet hose 21659720
- Clamp 504257
- Clamp 504324

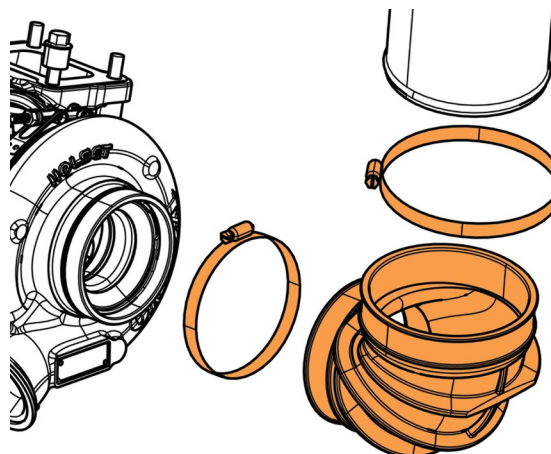

4. Reuse this part from the old turbo pipe:
- Indicator, filter restriction 530161

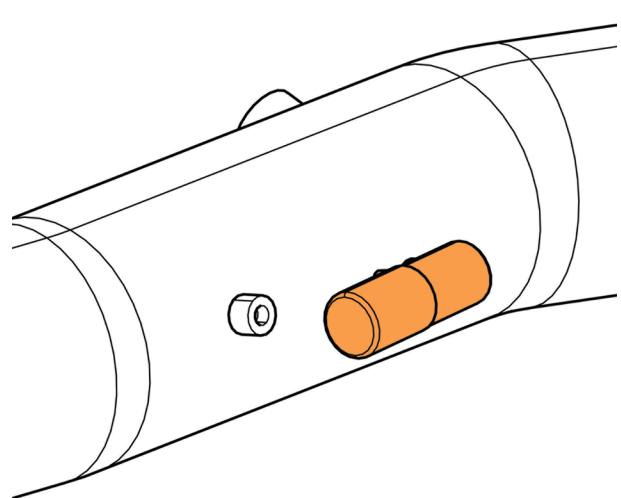

5. Discard the rest of air intake (hose, pipe and air filter and hardware).

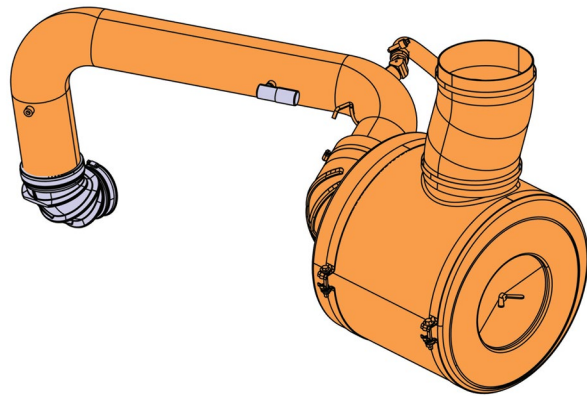

- Only vehicle with slide-out reinforcement**
6. Drain power steering tank oil and remove it.

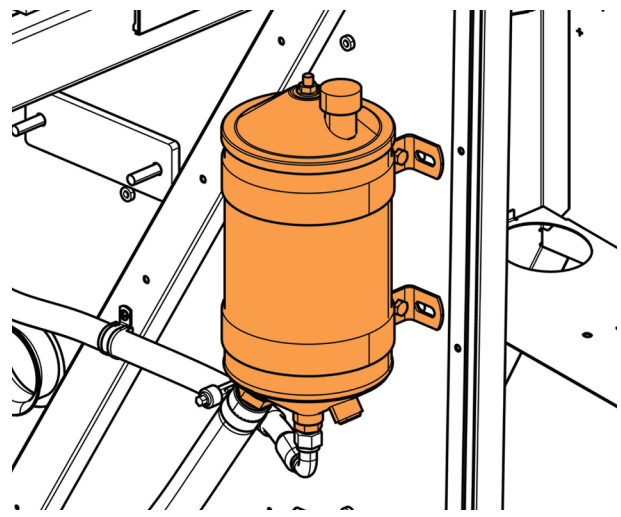

7. Recover refrigerant as required by local authorities.
8. Remove the system.
9. Prevent moisture to get in the air condition circuit Add plastic cap on all open fitting and remove it when you ready to re-install.

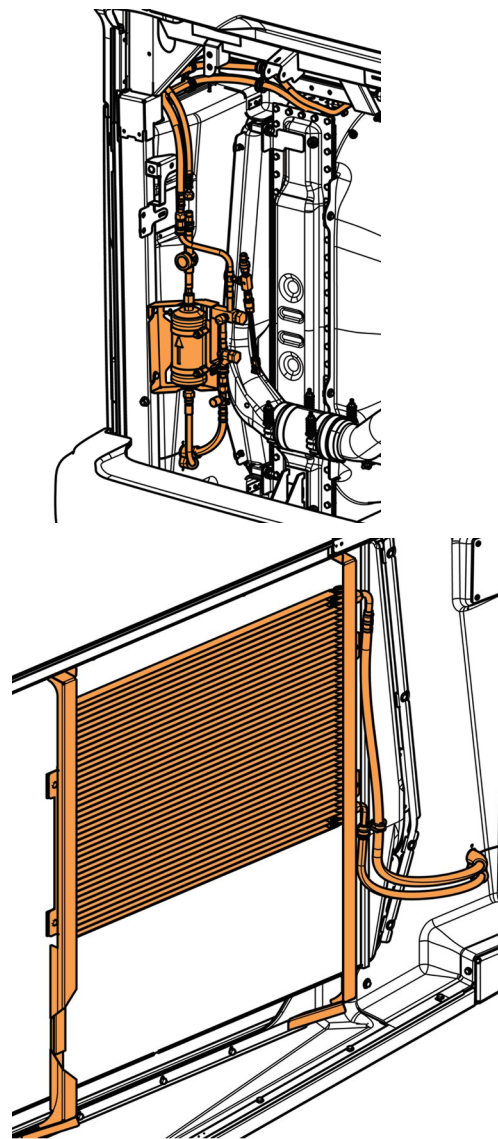

10. Reuse the dryer assembly.
11. Replace filter dryer 950370.
12. Prevent moisture to get in the air condition circuit Add plastic cap on all open fitting and remove it when you ready to re-install.

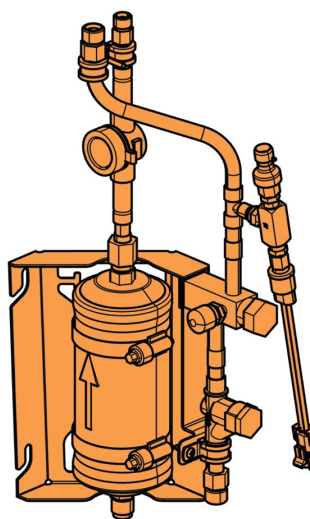

13. Discard the rest of condenser, hoses, and hardware.

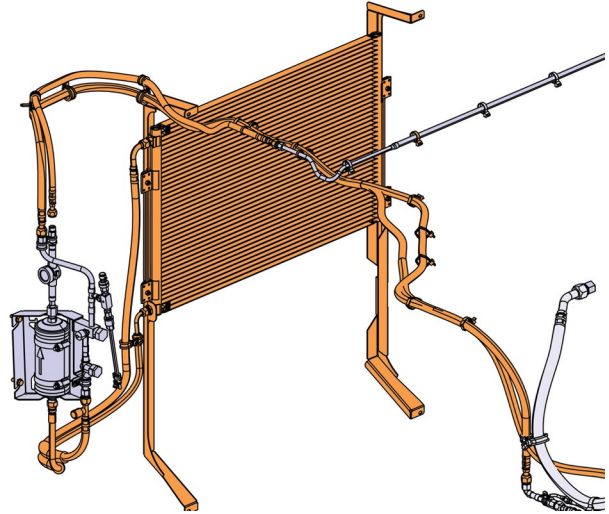

Only vehicle with slide-out reinforcement
14. If needed it, cut those tube of the structure.

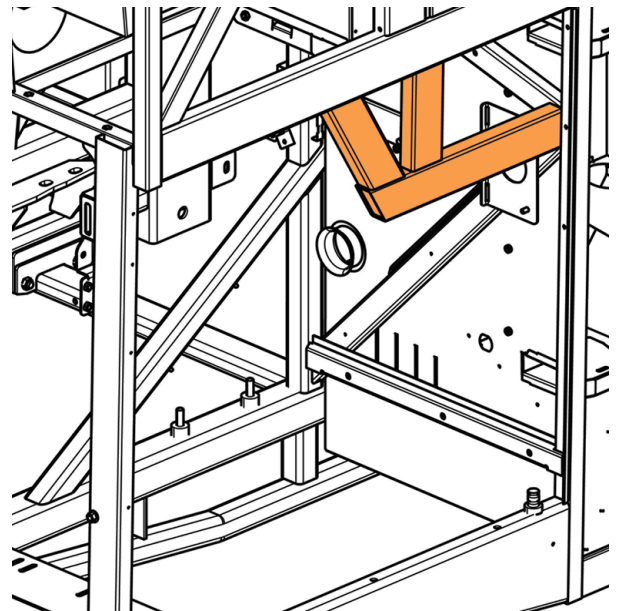

B. PART TO WELD



CAUTION

Disconnect all electronic modules to prevent any damage prior to welding.

Refer to MULTIPLEX MODULE DISCONNECTION PROCEDURE see maintenance manual section 00a for your vehicle

Welding setting see Appendix A



CAUTION

Welding should be performed by a qualified welder using the appropriate personal protection equipment.

Install OSHA safe portable welding screens or curtains around the work area to protect bystanders.

For vehicle without slide-out reinforcement

1. Assemble bracket 2810648 (2x) to support assembly 454764 using bolts 5001981 (2x), washers 5001849 (4x), spacers 286716 (4x) and nylon lock nuts 5001787 (2x).
2. Assemble angular 218982 to support assembly 454764 using bolt 502862 lock washer 500942, washer 500332.

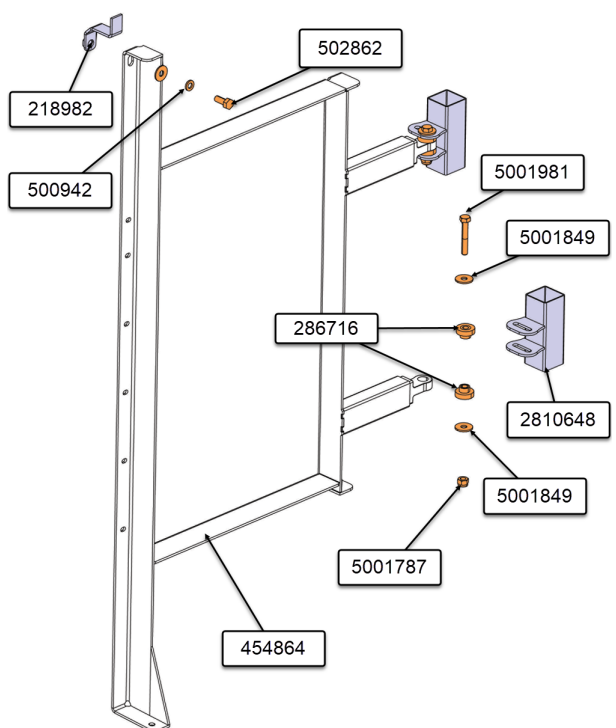

3. Fixe the assembly with clamps.

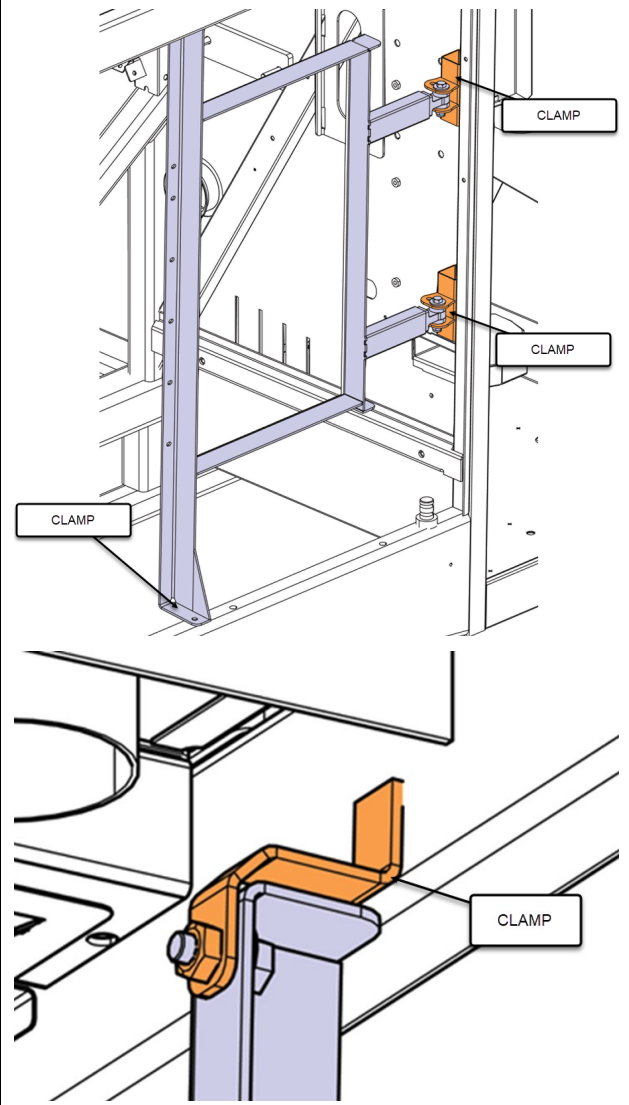

4. Tack weld bracket 2810648 and angular 218982 to the structure.

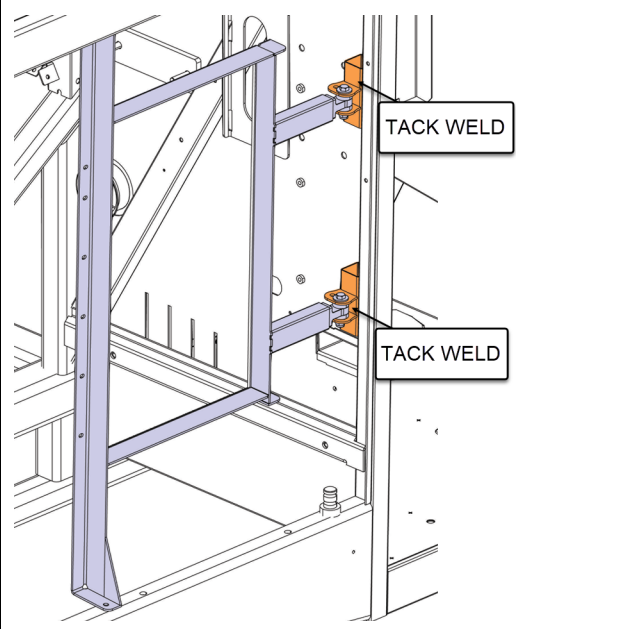

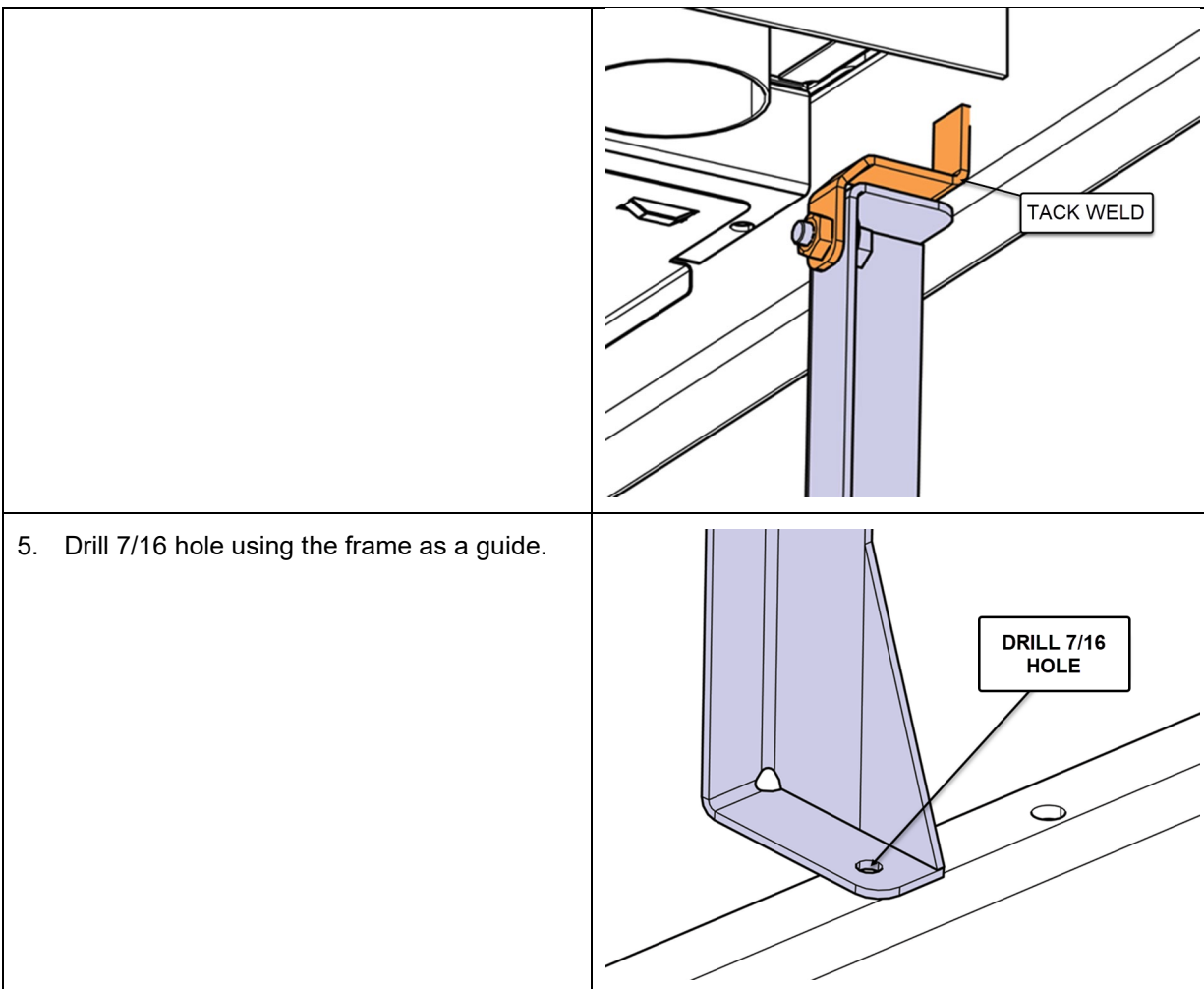

6. Remove support 454764, bolts 5001981 (2x), washers 5001849 (4x), spacers 286716 (4x) and nylon lock nuts 5001787 (2x) bolt 502862 lock washer 500942, washer 500332 to support assembly 454764 .

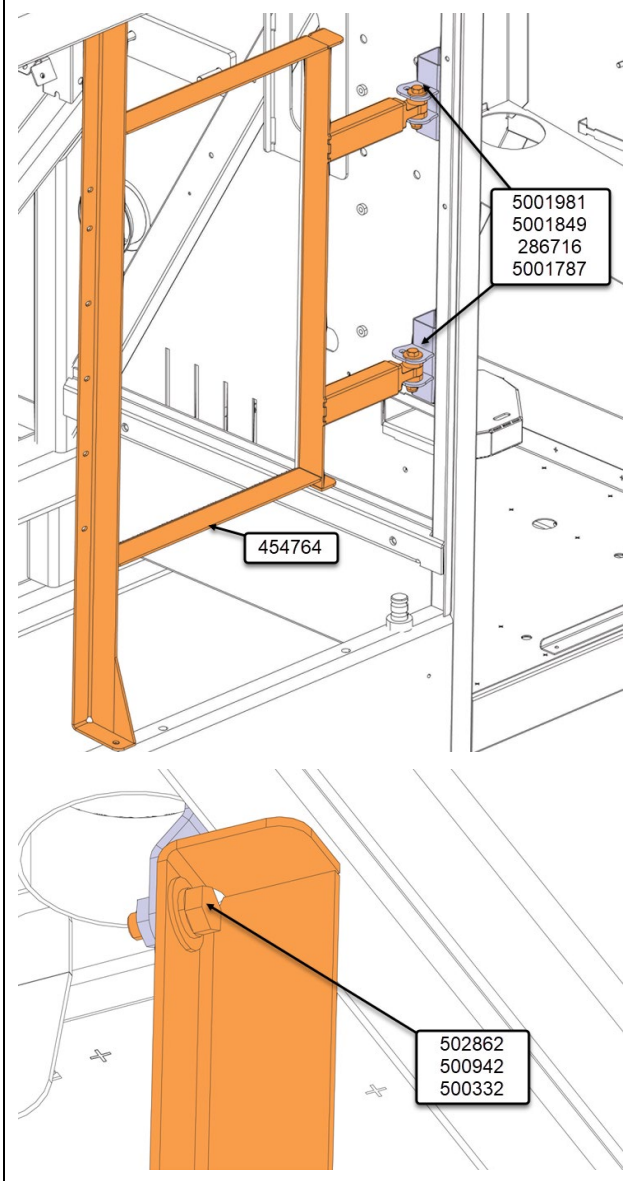

7. Weld 2810648 (2X) see images below.

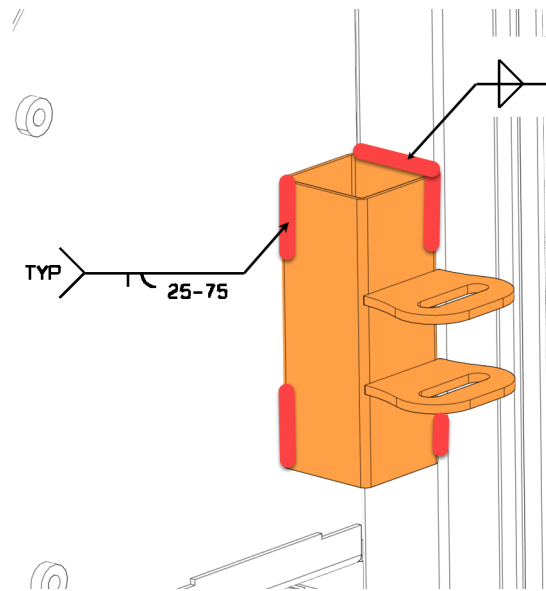
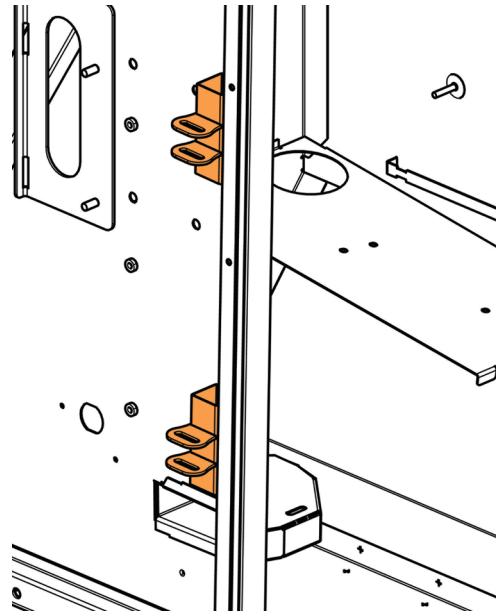

8. Weld 218982 see image.

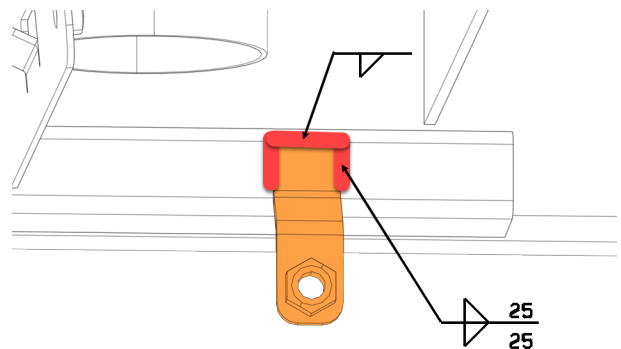

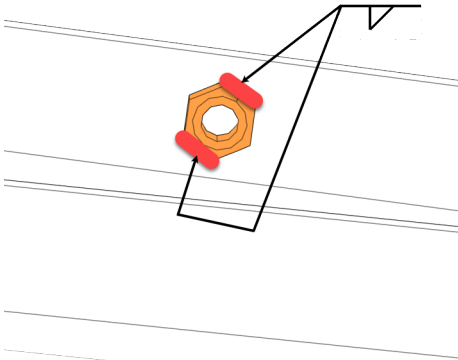
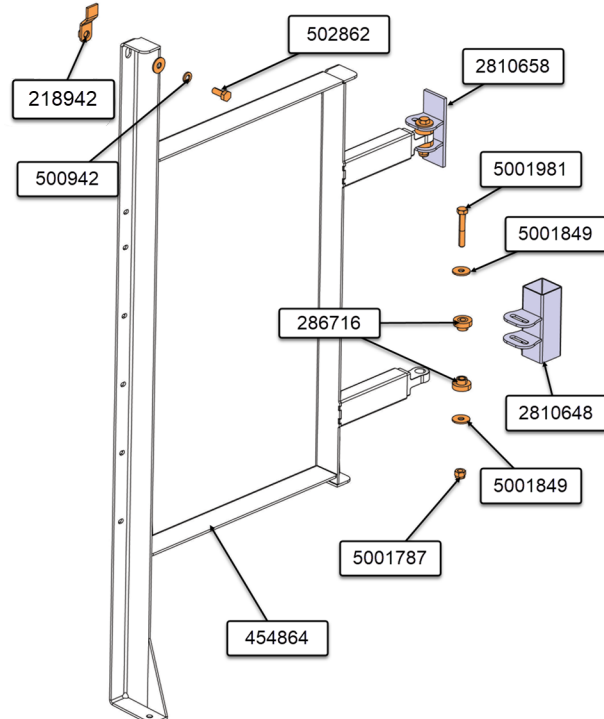
<p>9. Weld the nut 502609 on two face.</p>	 A technical drawing showing a hexagonal nut with two red arrows pointing to its top and bottom faces, indicating where it should be welded to a metal structure. The nut is shown in a perspective view, and the metal surface it is being attached to is represented by several parallel lines.
<p>Only vehicle with slide-out reinforcement</p> <ol style="list-style-type: none">1. Assemble bracket 2810648 (lower) and bracket 2810658 (upper) to support assembly 454764 using bolts 5001981 (2x), washers 5001849 (4x), spacers 286716 (4x) and nylon lock nuts 5001787 (2x).2. Assemble angular 218942 to support assembly 454764 using bolt 502862 lock washer 500942, washer 500332 .	 An exploded view diagram of a support assembly. The main vertical component is labeled 454864. To its right, there are two brackets: 2810648 (lower) and 2810658 (upper). Various bolts, washers, spacers, and lock nuts are shown being assembled onto the brackets and the main vertical component. The parts are labeled with their respective part numbers: 218942 (angular), 500942 (lock washer), 502862 (bolt), 286716 (spacers), 5001981 (bolts), 5001849 (washers), 5001787 (nylon lock nuts), and 454764 (assembly). The diagram shows the assembly sequence from the main vertical component up to the top brackets.

10. Fixe the assembly with clamps.

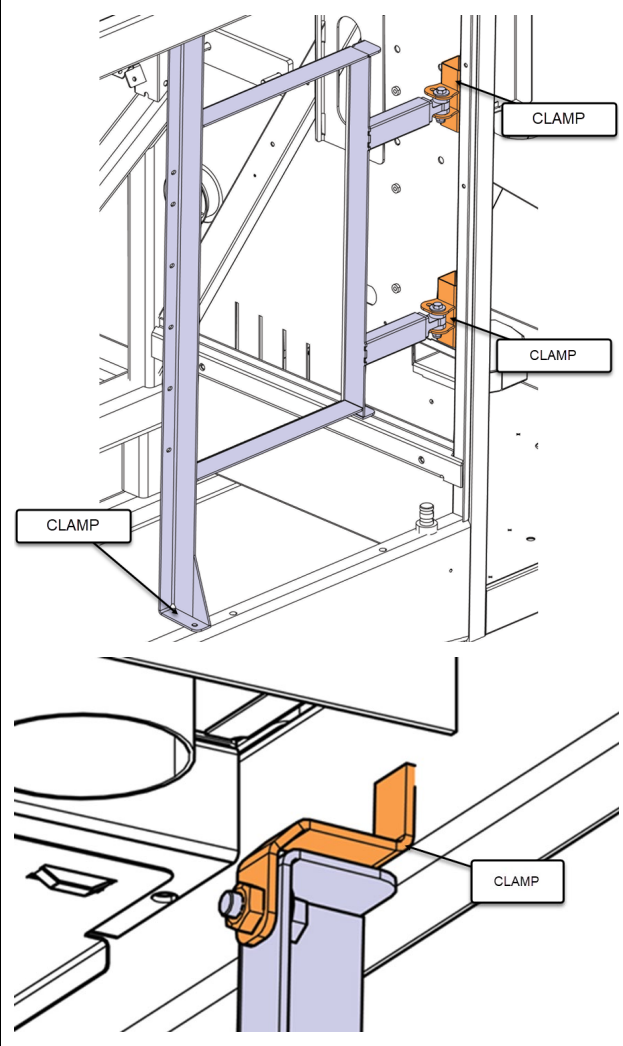

11. Tack weld brackets 2810648 and 2810658 and angular 218942 to the structure.

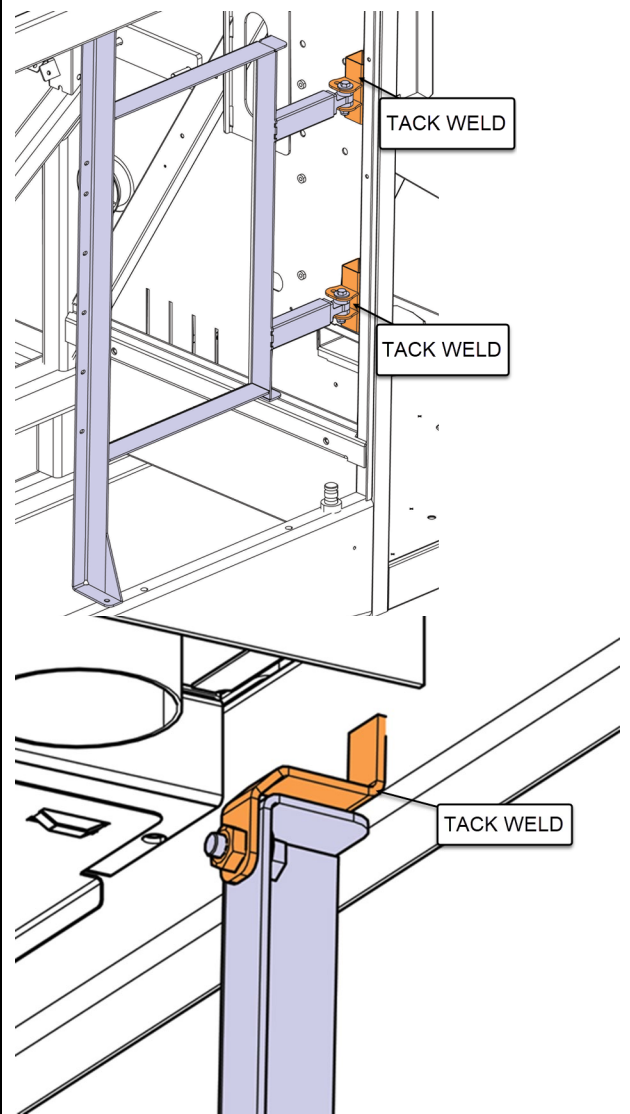

12. Drill 7/16 hole using the frame as a guide.

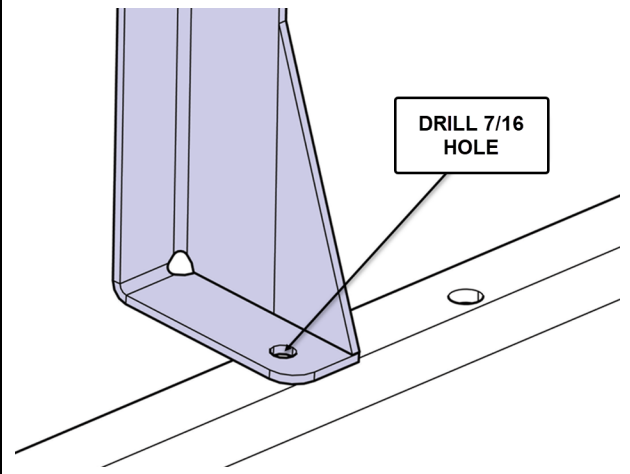

13. Remove support 454764, bolts 5001981 (2x), washers 5001849 (4x), spacers 286716 (4x) and nylon lock nuts 5001787 (2x) bolt 502862 lock washer 500942, washer 500332 to support assembly 454764 .

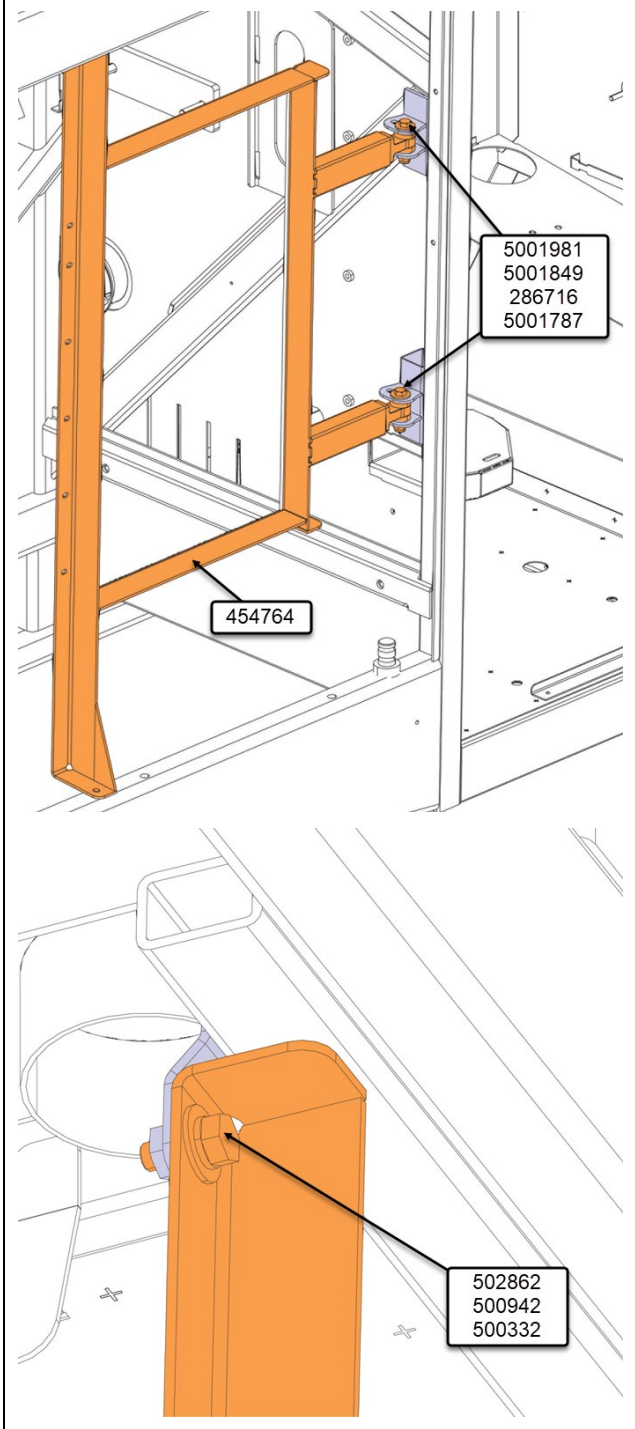

14. Weld brackets 2810658 and 2810648.

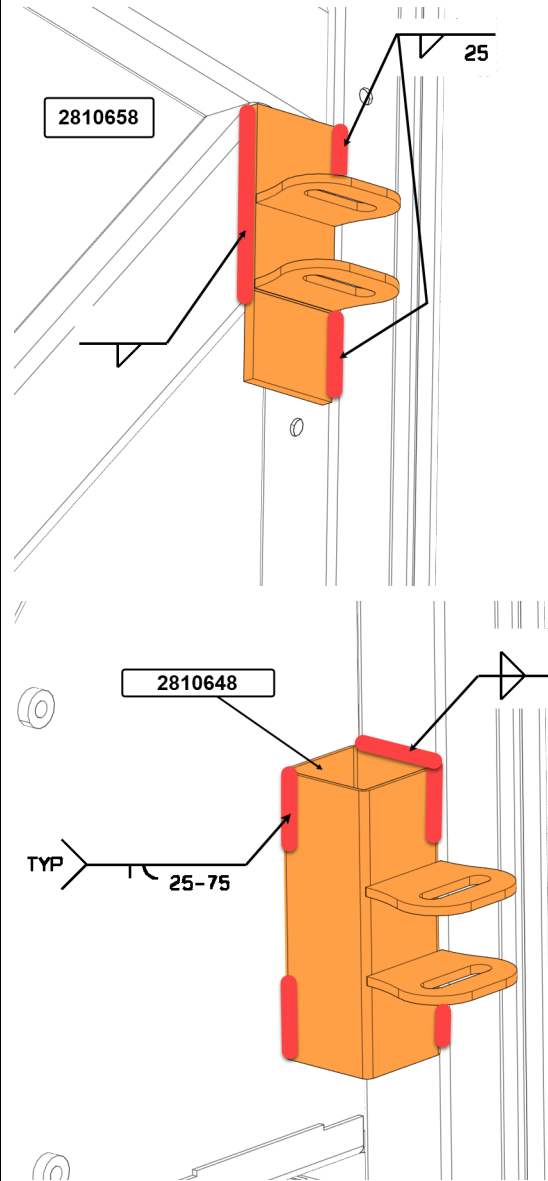

15. Weld 218942 see image.

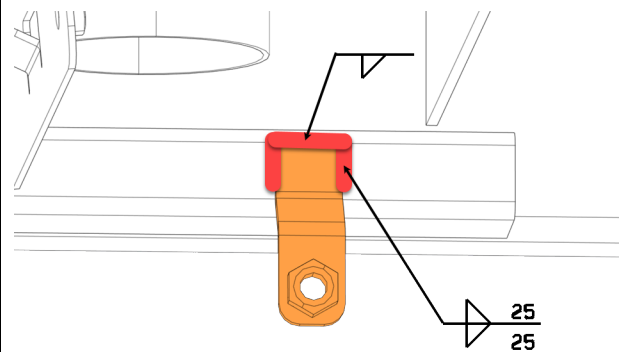

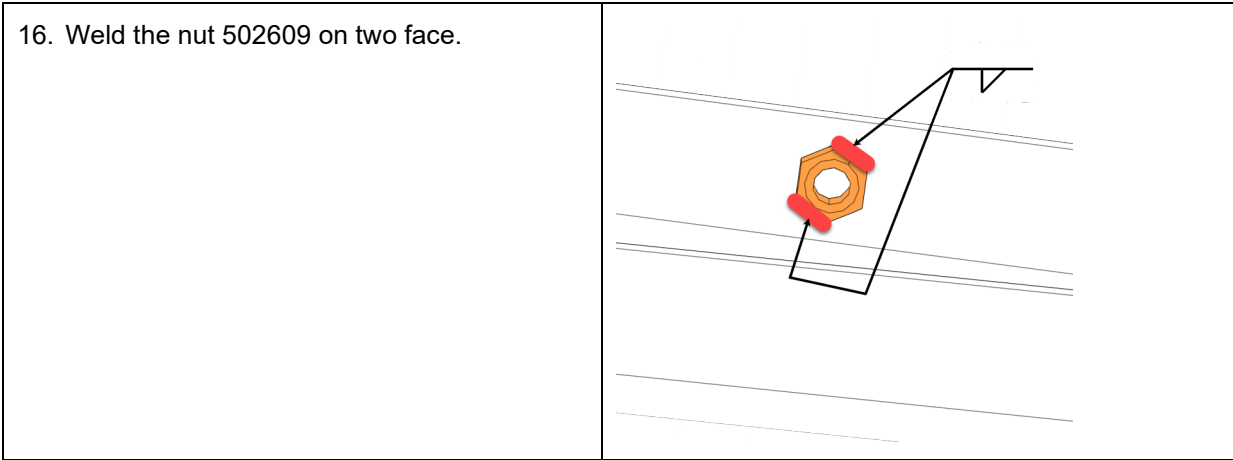

Weld section Air Filter and Air Dryer

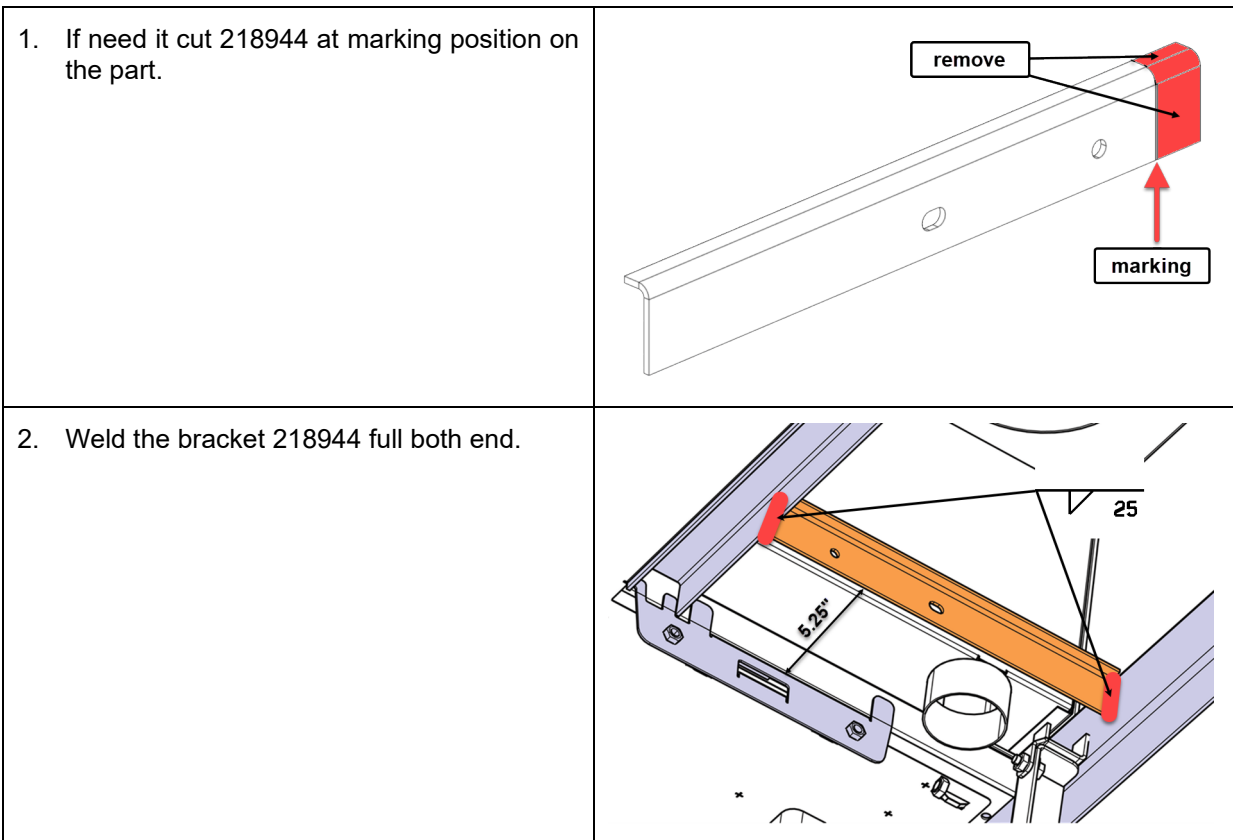

3. Assemble bracket 218943 to bracket 454892 using washer 500332 and nut 5001931.
4. Assemble bracket 454892 to bracket 454888 using washers 500332 (2x) and nuts 5001931 (2x).
5. Assemble bracket 454893 to bracket 454888 using bolts 502780 (2x) and washers 5001868 (2x).
6. Assemble bracket 218948 to bracket 454888 using washers 500332 (2x) and nuts 5001931 (2x).

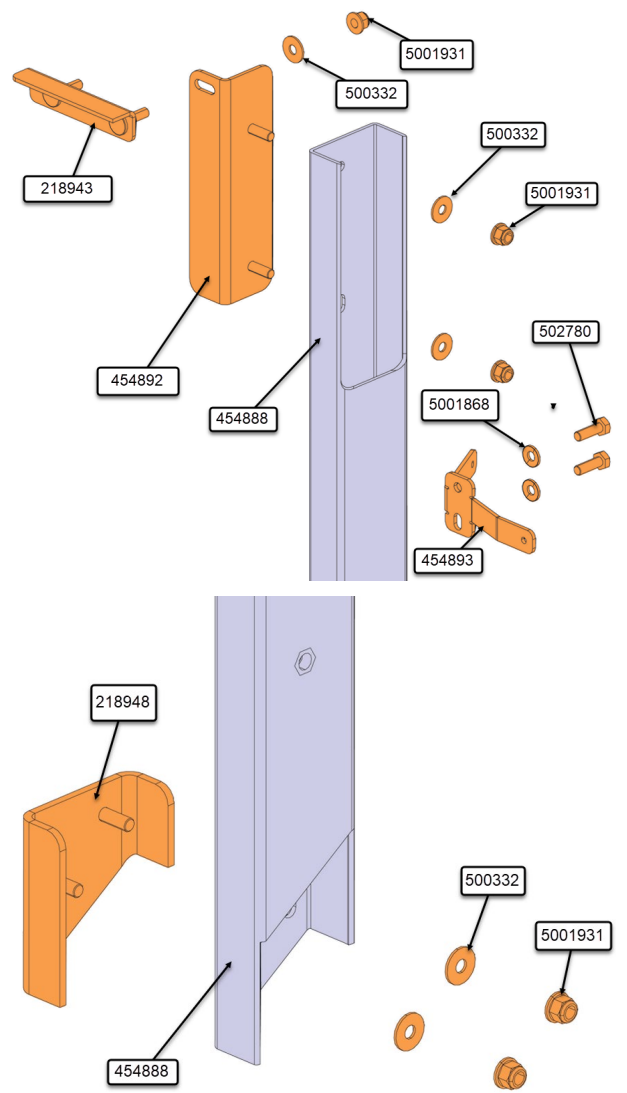

7. Tack weld lower section of the assembly.

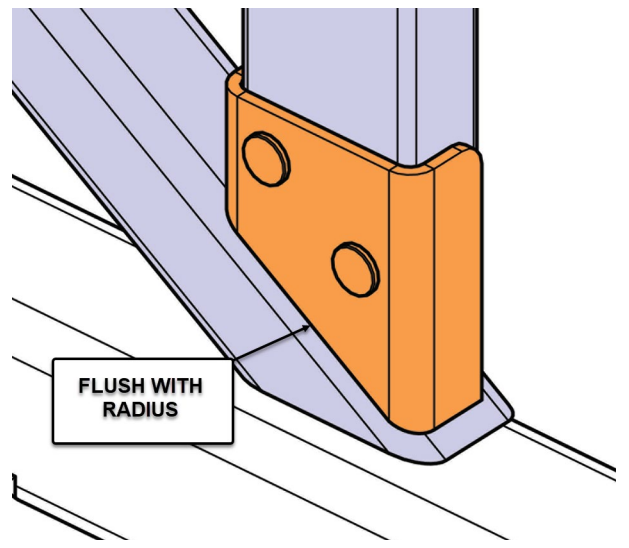
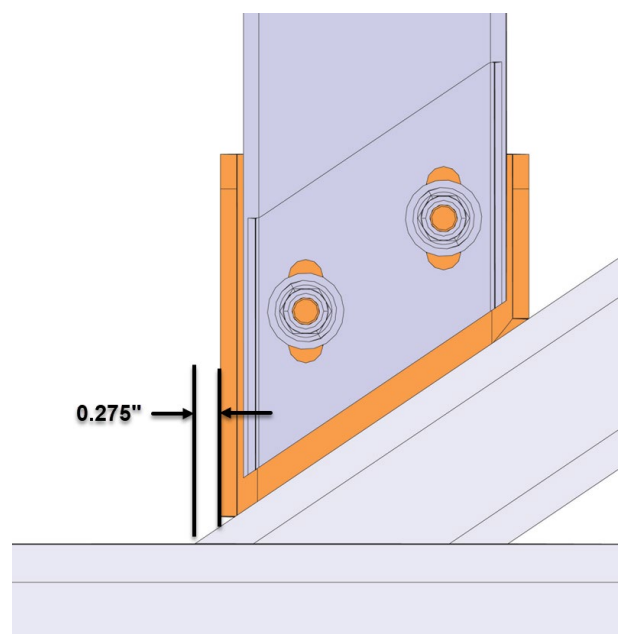

8. Tack weld lower section of the assembly.

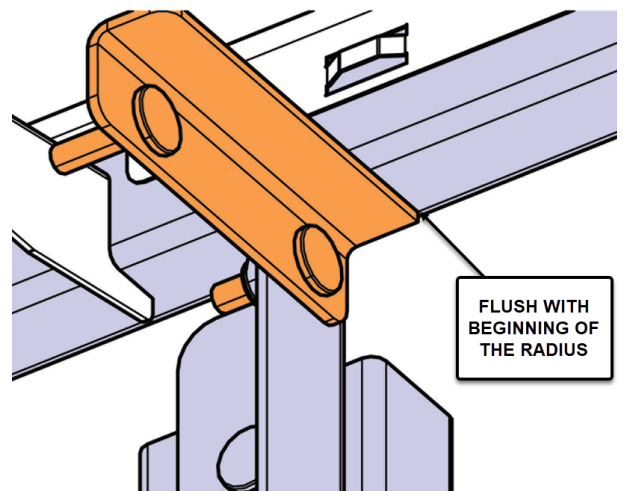

9. Remove the assembly, nuts 5001931 (3x) and washers 500332 (3x).

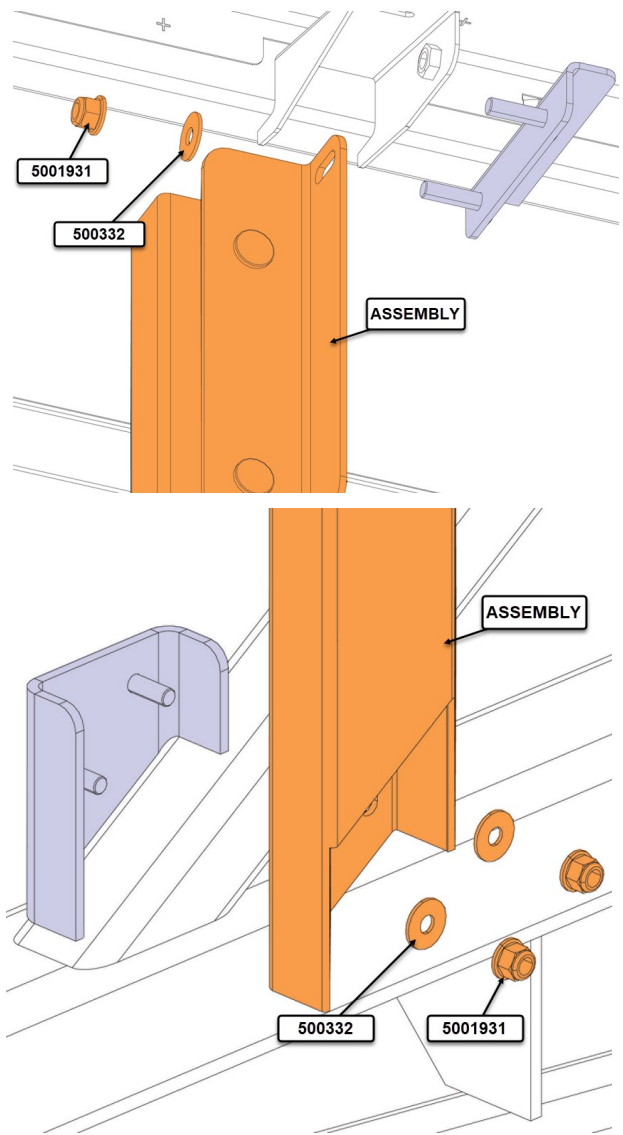

10. Weld 281948 full inside and outside.

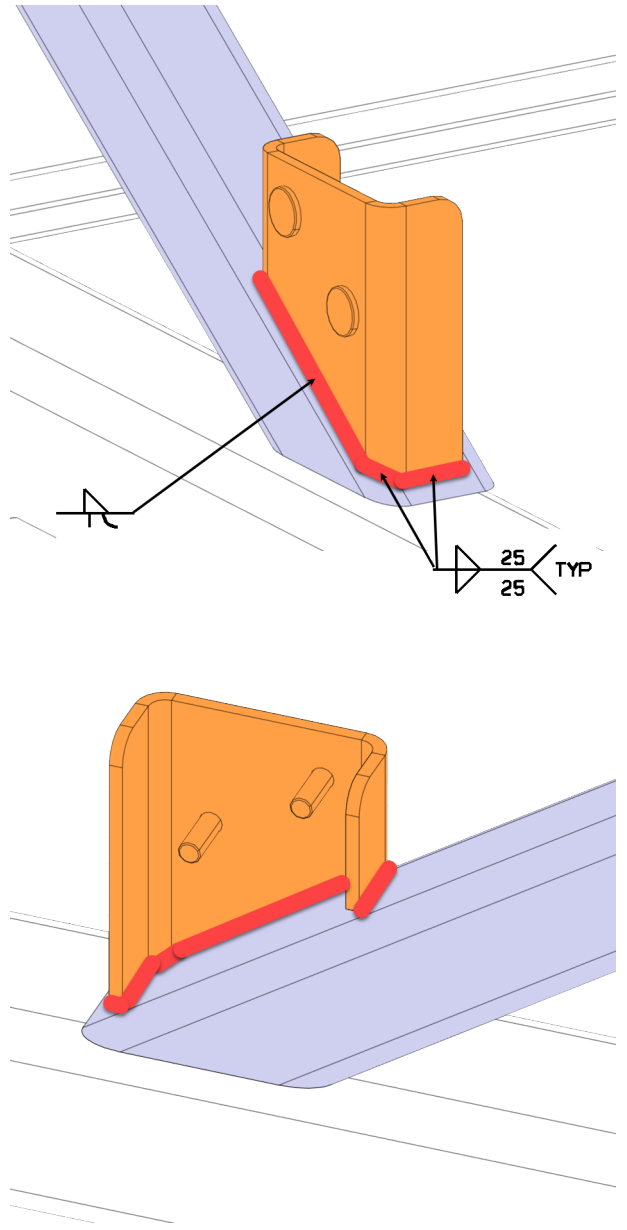

11. Weld 281943 see image.

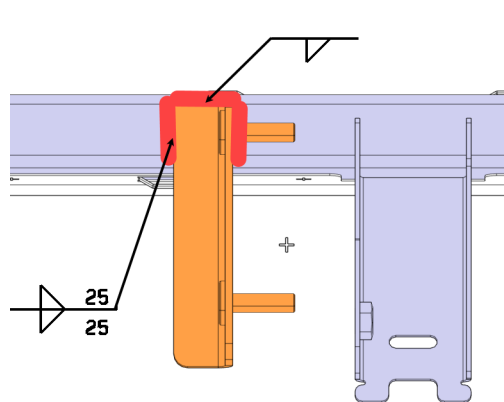

Only vehicle with slide-out reinforcement

12. Weld the new Support 218949 see image.

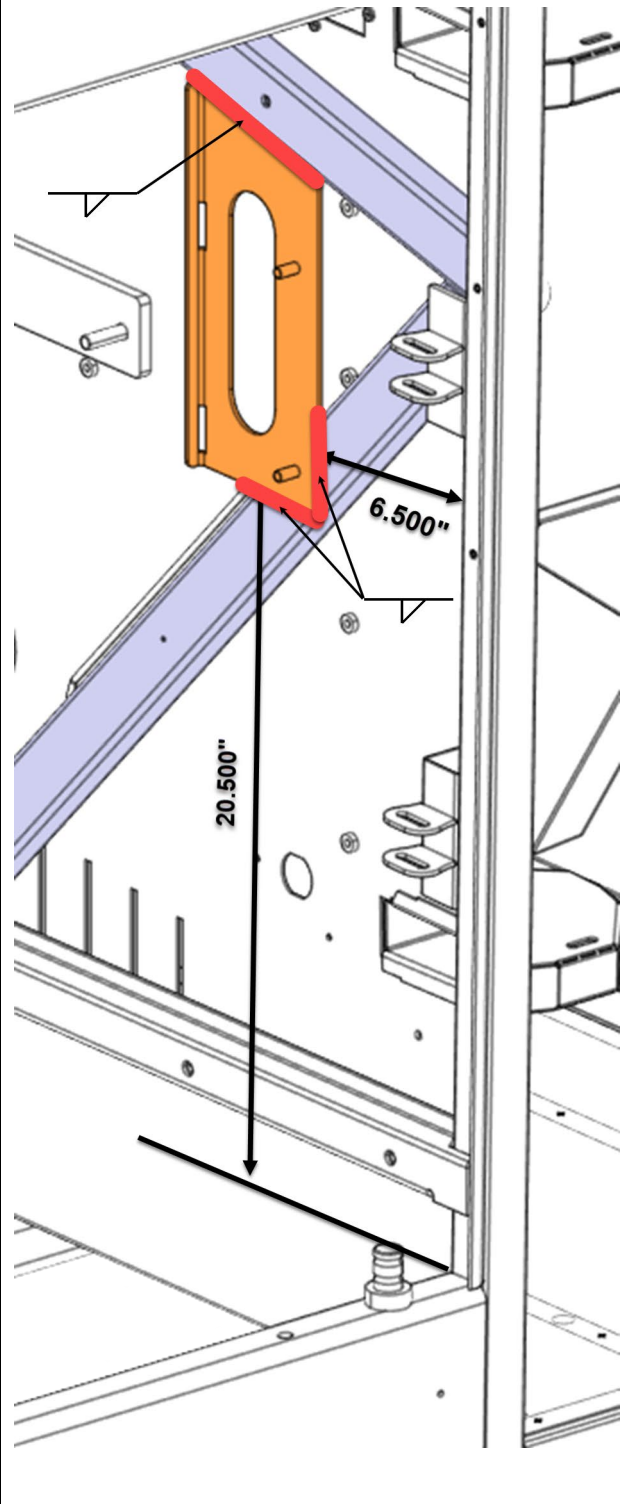

C. AIR FILTER INSTALLATION

1. Install the assembly using nuts 5001931 (3x) and washers 500332 (3x).

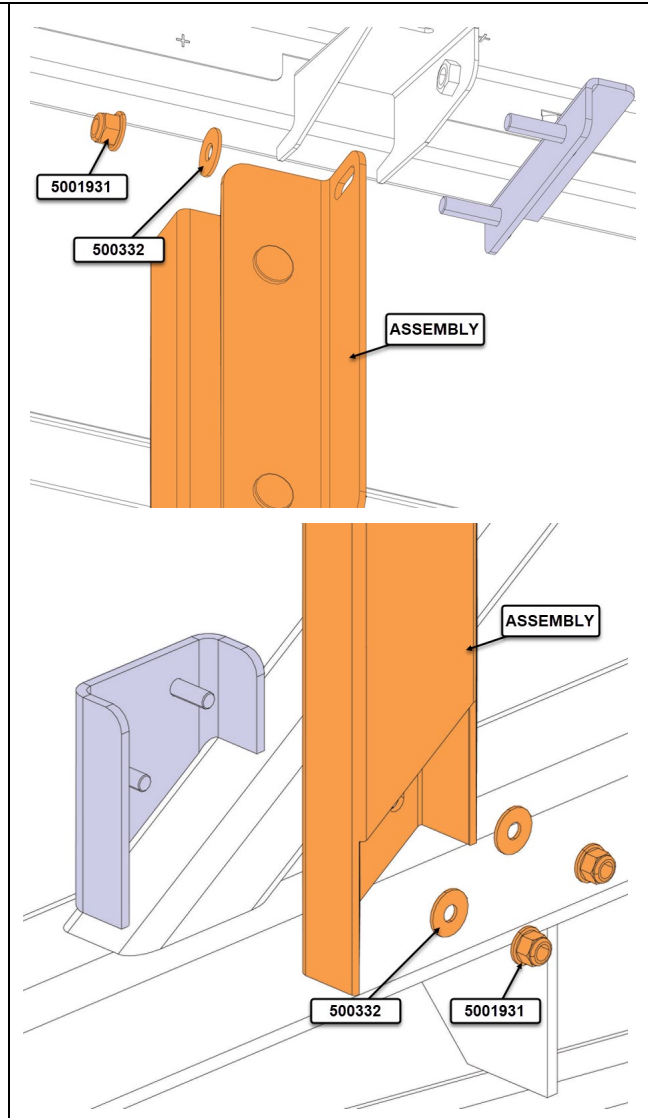

3. Drill 2 holes .375" use for the fixation of bracket 030292.

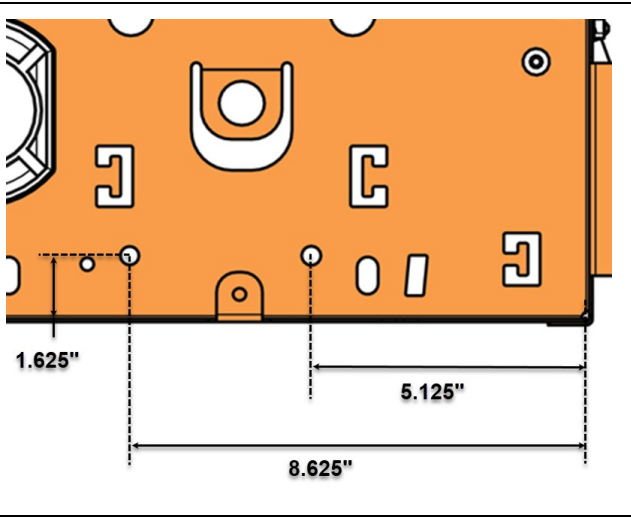

4. If need your vehicle is built before GHG 2017 you need to install this adapter 030232. Clamp the adapter and drill (#40) 3 holes using rivet 504339 (3x) fixe in place.

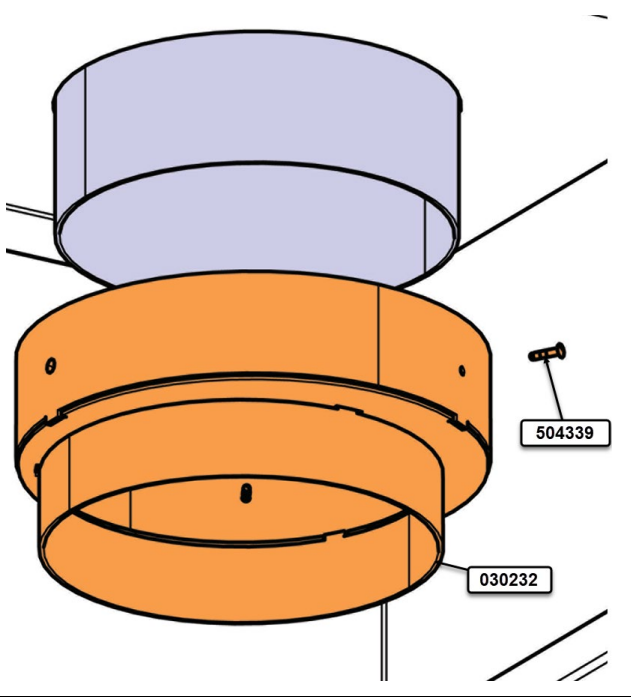

5. Install the bracket front 030293 using bolts 502862 (2x), washers 5001931 (2x) and nuts 502692 (2x).

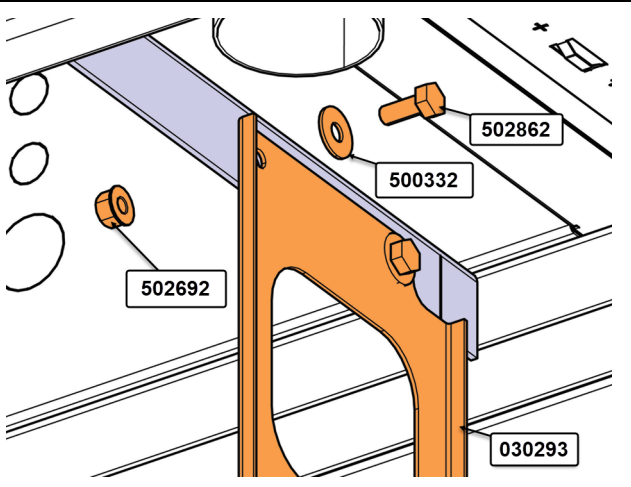

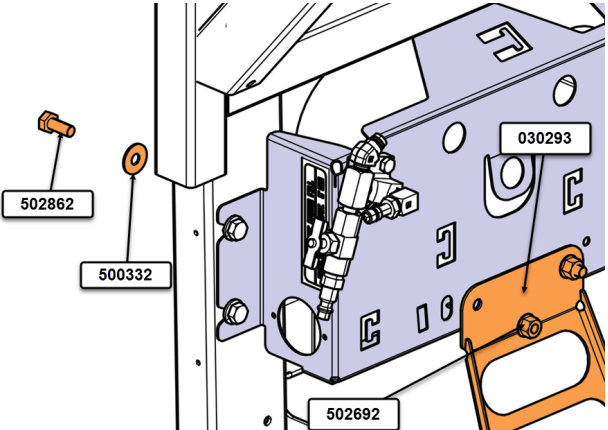
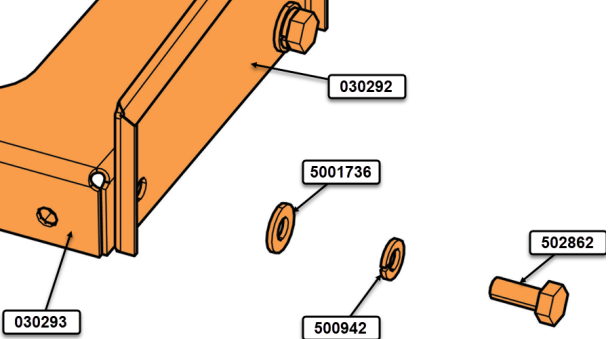
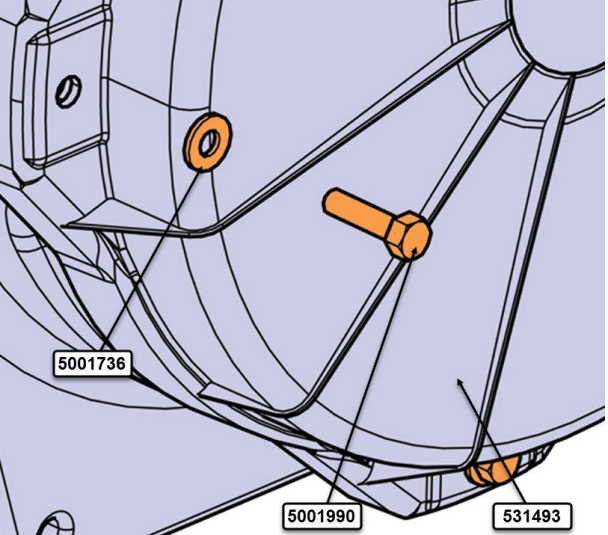
<p>6. Install the bracket rear 030292 using bolts 502862 (2x), washers 500332 (2x) and nuts 502692 (2x).</p>	
<p>7. Fixe together brackets 030292 and 030293 using bolts 502862 (2x), lock washers 500942 (2x) and washers 5001736 (2x).</p>	
<p>8. Remove bolts fixing cover of air filter 531493 and replace it with bolts 5001990 (4x) and washers 5001736 (4x).</p>	

9. Install the air filter 531493 on bracket 030292 using bolts 502836 (4x), lock washers 500942 (4x) and washers 5001736 (4x).

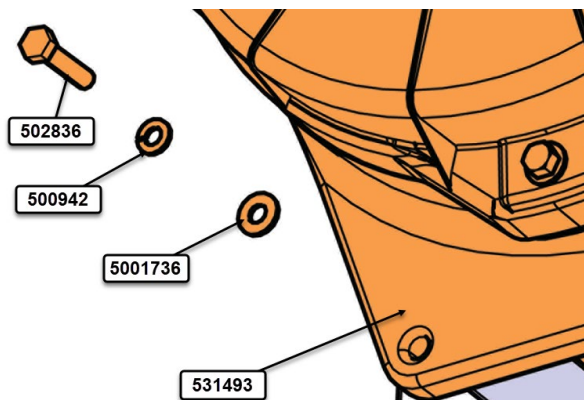

10. Install hose 030286 (1x) between vehicle air intake and air filter using clamp 504229 (2x).

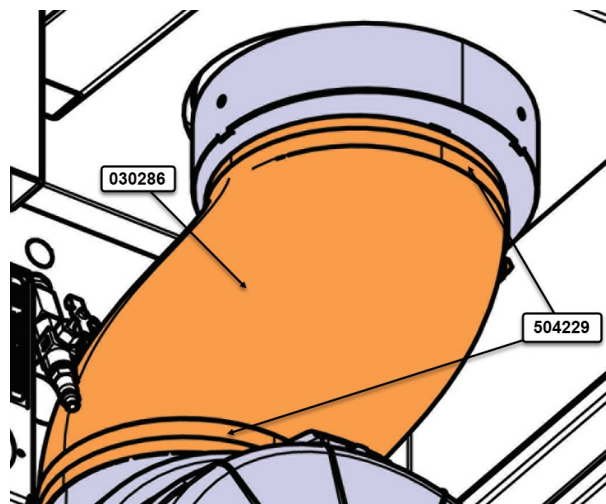

11. Install reducer 531363 (1x) on air filter 531493 using clamp 504229 (1x).

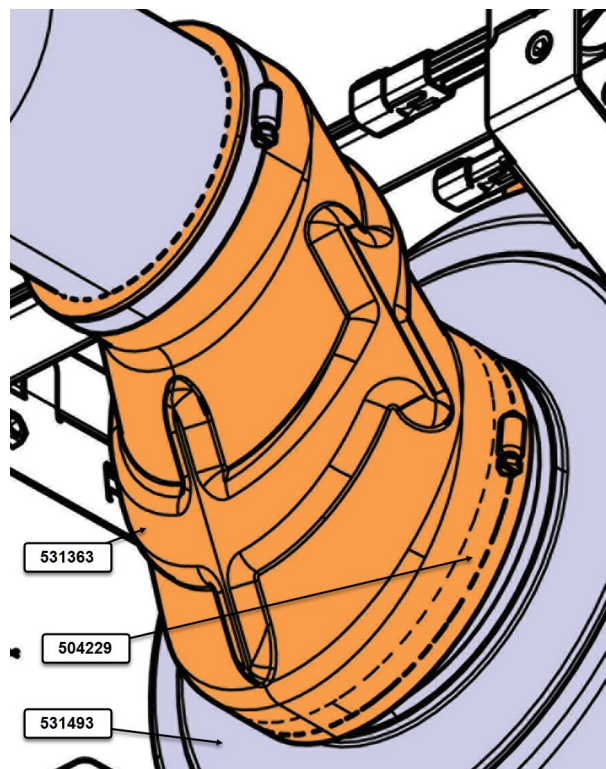

12. Re-install inlet hose 21659720 (1x) using clamp 504257 (1x).

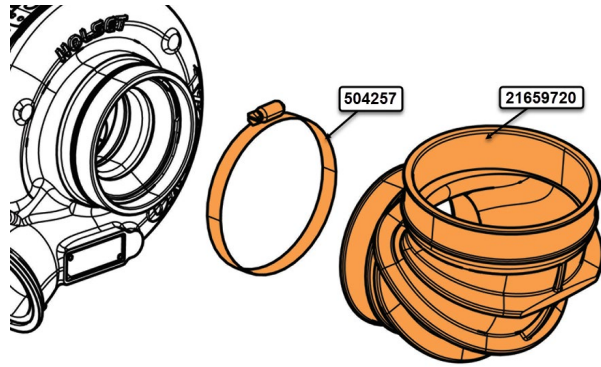

13. Install air pipe 030053 (1x) on 531363 reducer using clamp 504324 (1X).

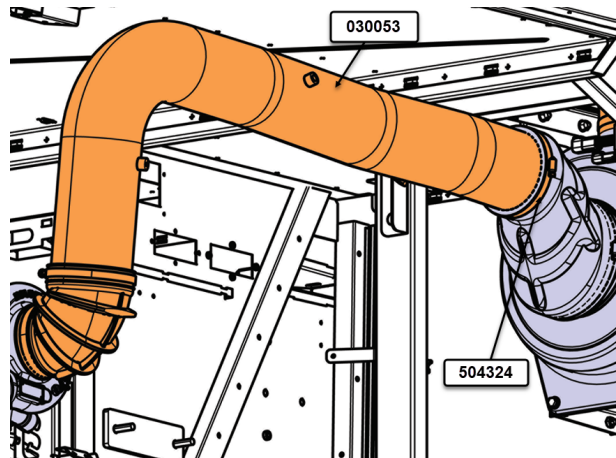

14. Install air pipe 030053 on inlet hose 21659720 re-install clamp 504324 (1x).

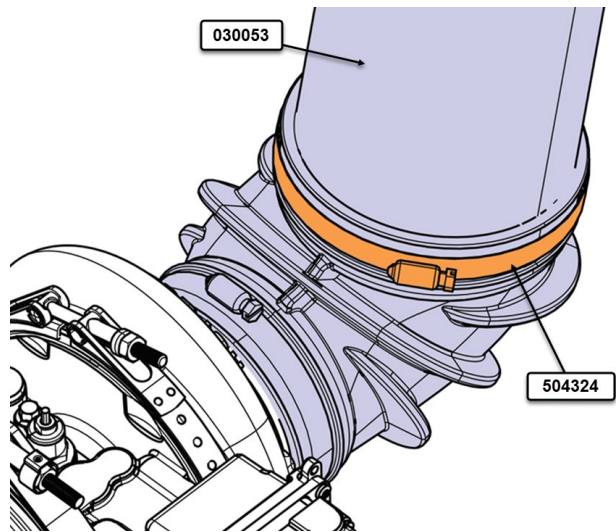

15. Install bracket 032541 on pipe 030053 using spacer 032540, (1x) washer 500332 (1x) and nut 5001931 (1x).

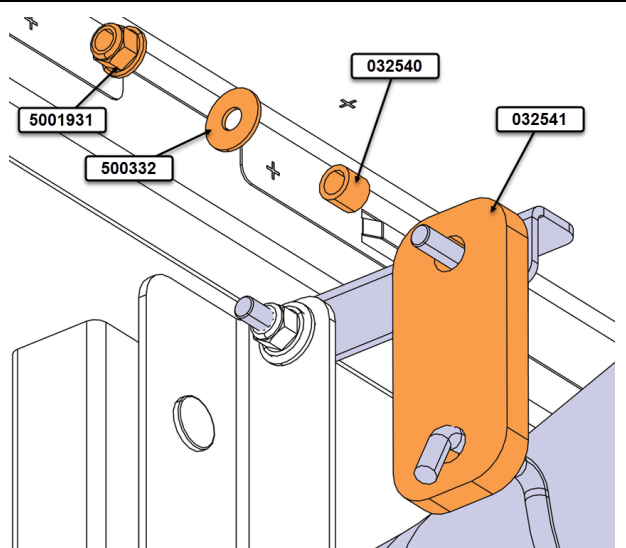

16. Re-install Indicator, filter restriction 530161.

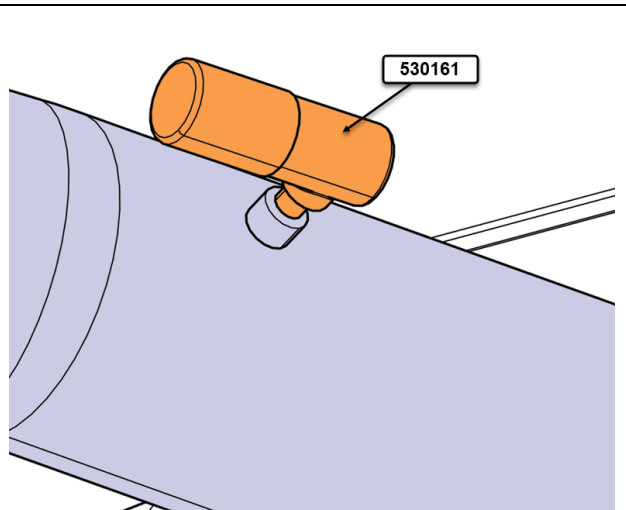

17. Install hose 030291 (1x) between pipe 030053 and air compressor using adapter 5011240 (1x) and clamp 504291 (2x).

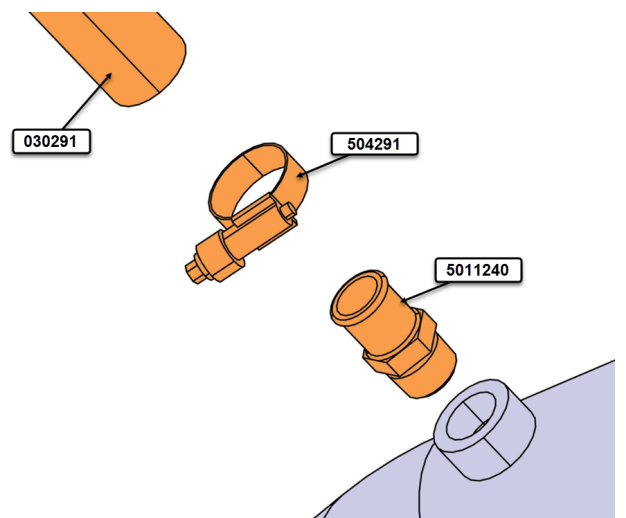

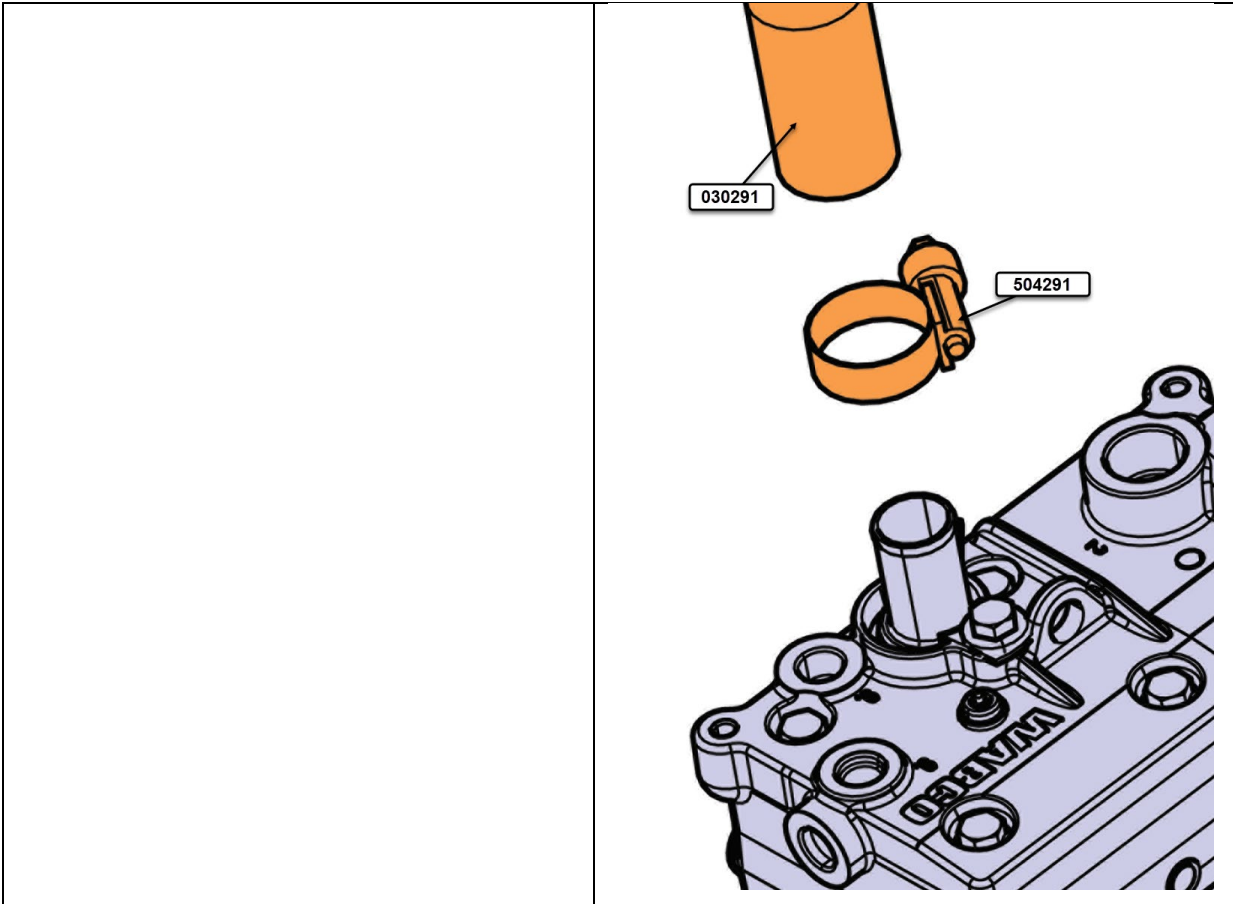

18. Install decals 030045 (1x), 030046 (1x), 034005 (1x).

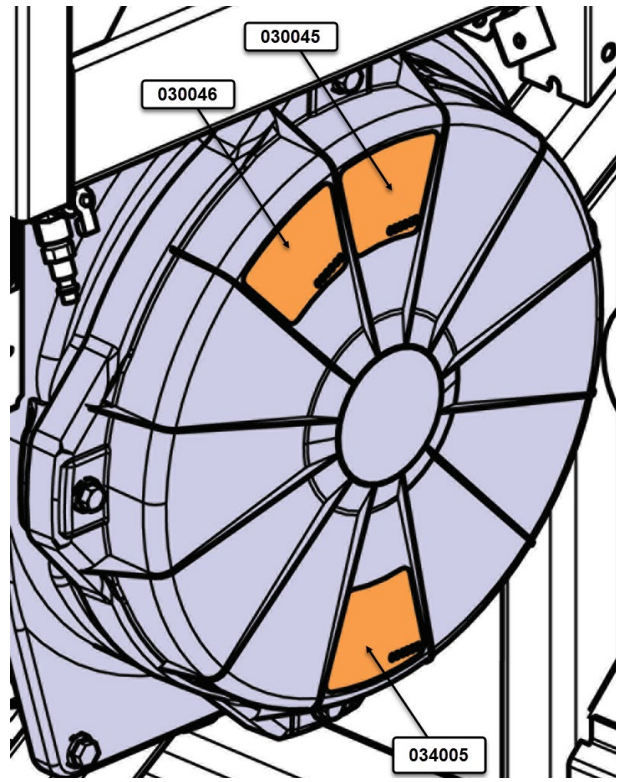

D. COMPRESSOR DOOR MODIFICATION

1. Install rubber plugs 504709 (2x) on panel 2810653.

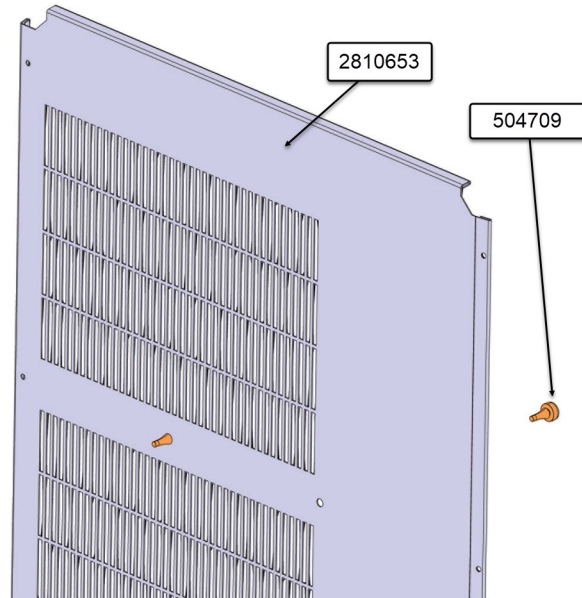

2. Install panel 2810653 on compressor door using screws 509805 (6x).

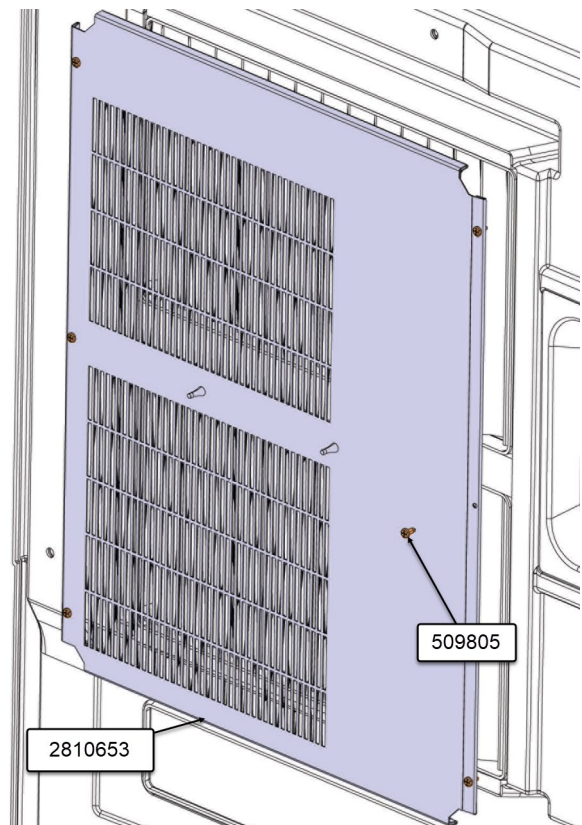

E. CONDENSER INSTALLATION

1. Install tape 506228 (6.5ft) on 454864.
2. Fix 454864 to 950522 using 500283 (12x).

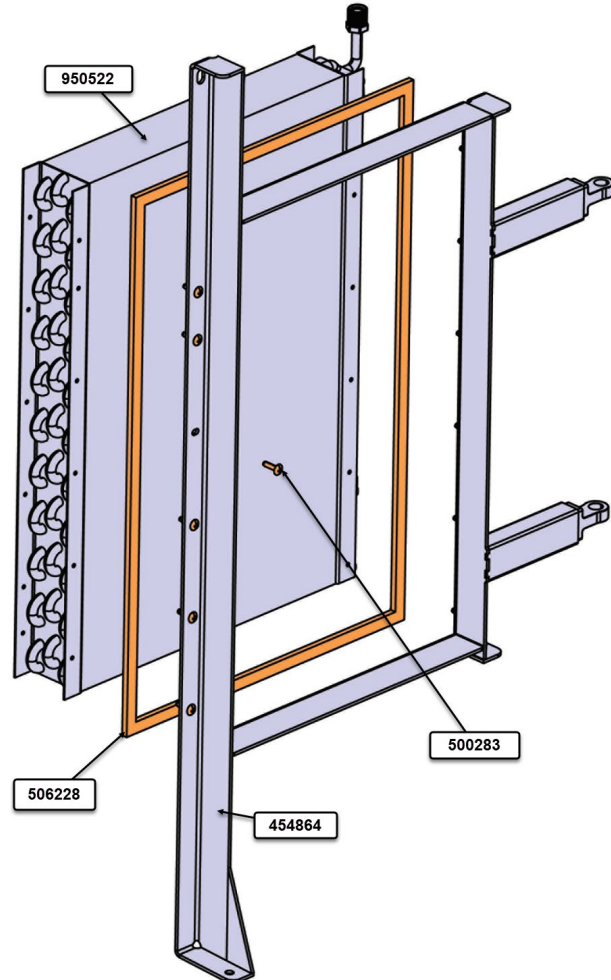

3. Install on 454864 rubber strip 506302 (7 ft).

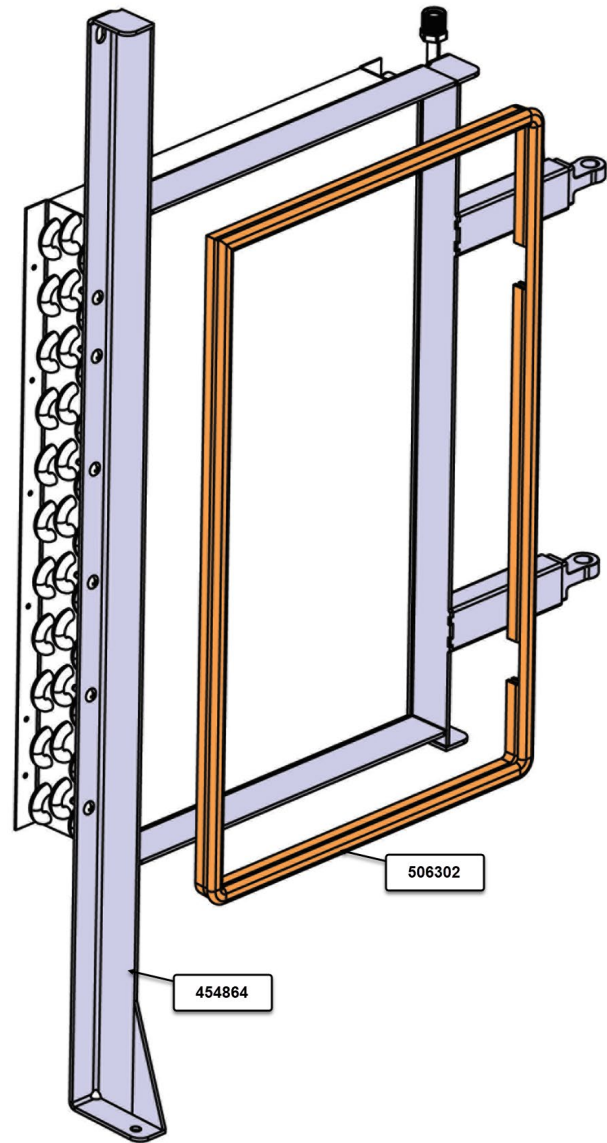

4. Install the shroud 454037 on condenser 950552 using screws 5001975 (14x) and washers 5001137 (14x).
5. Install clamps 952629 (3x).
6. Install cable tie mount 504013 (2x) on shroud using 504379 (2x).

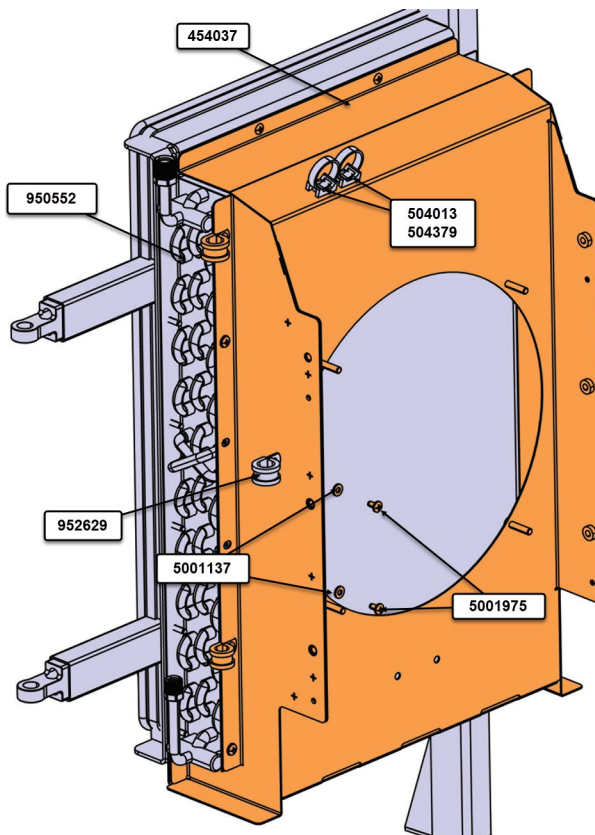

7. Install fan 565881 on shroud 454037 using nuts 5001851 (4x) and washers 5001833 (4x).
8. Install tree mounting 509815 (2x) .

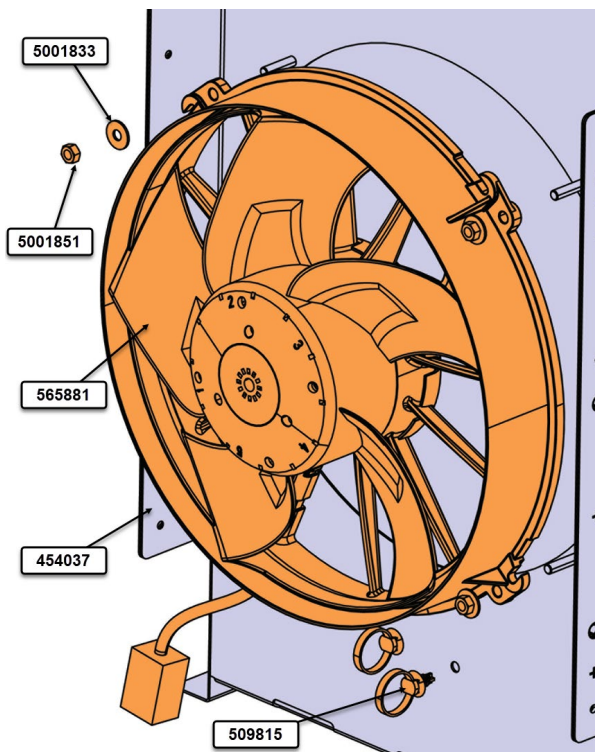

9. Install protective panel 454036 on shroud using bolts 5001697 (4x), lock washers 502853 (4x) & washers 500411 (4x).

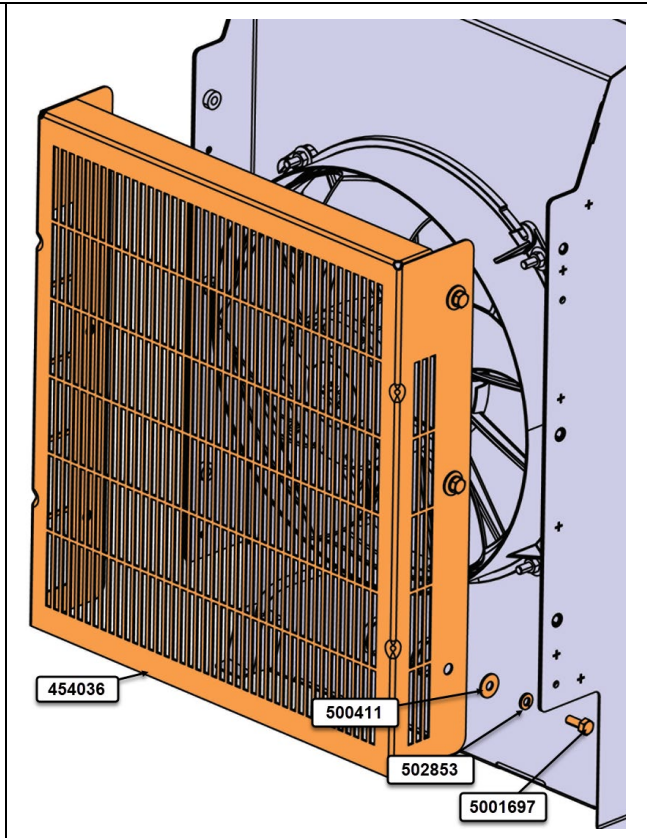

10. Install the left side of condenser assembly on the vehicle using bolts 5001981 (2x), washers 5001849 (4x), spacers 286716 (4x) and nylon lock nuts 5001787 (2x).

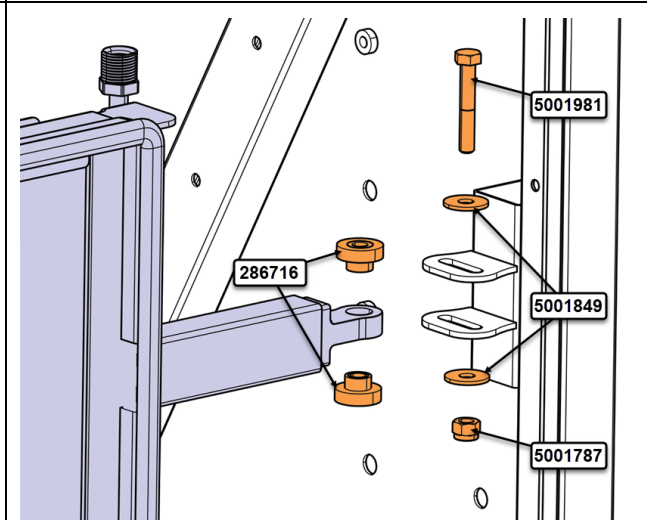

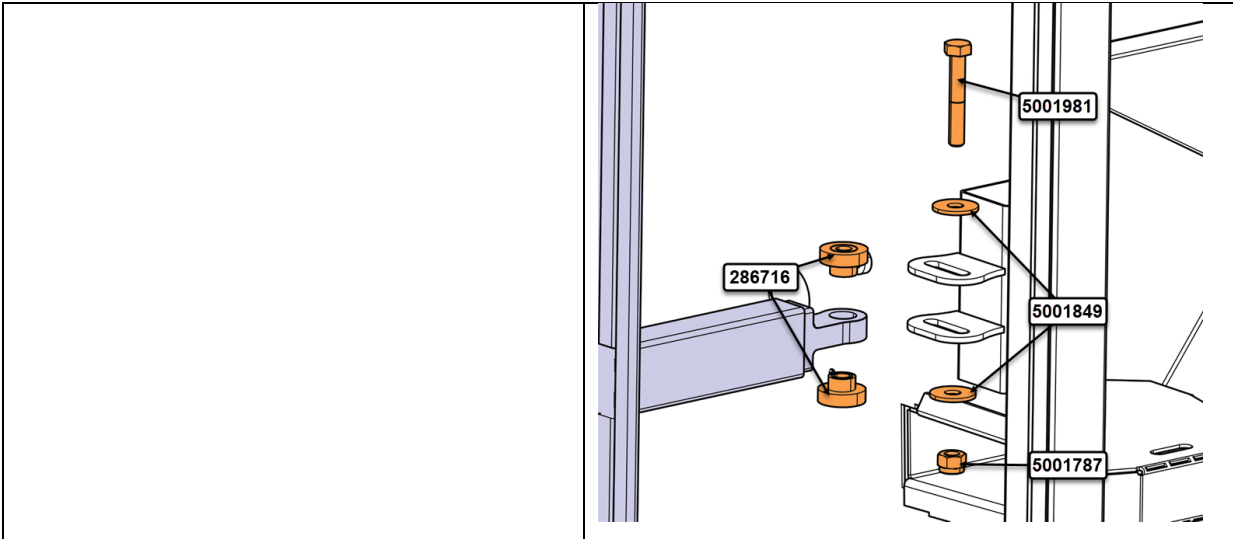

11. Install the right side of condenser assembly on the vehicle using bolts 502862 (2x), lock washers 500942 (2x), washer 500332 (2x).

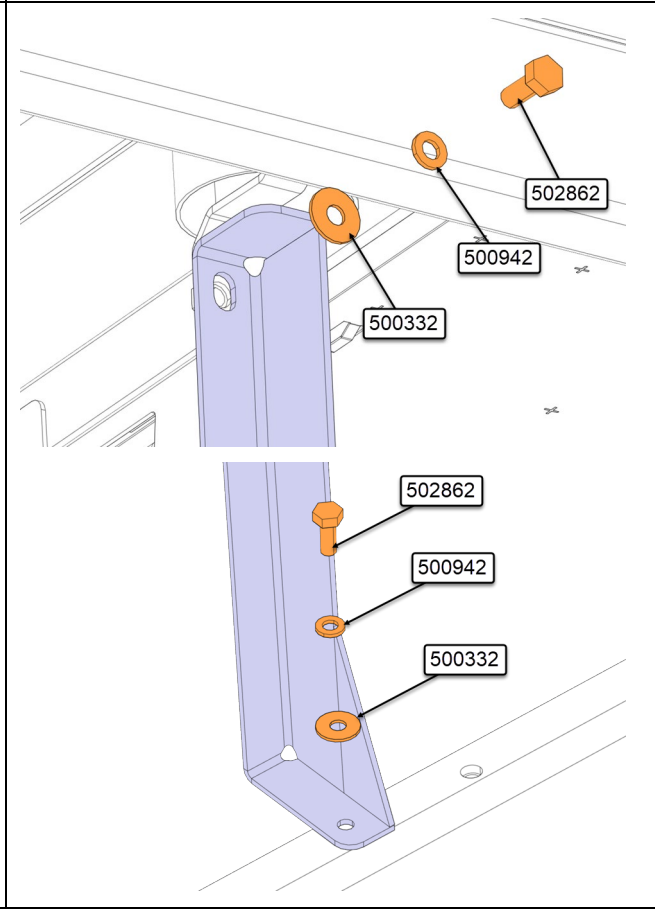

F. DRYER INSTALLATION

1. Assemble the pressure switch 950270 with connector 561566 (1x), wire seal 561565 (2x) and Terminal 561567 (2x).

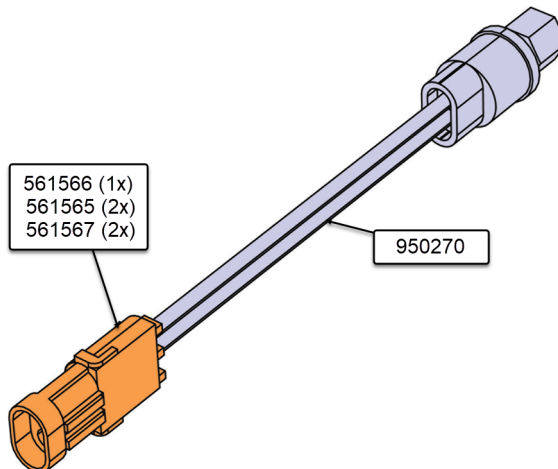

2. Uninstall pressure transducer 563423 and valve 950249.

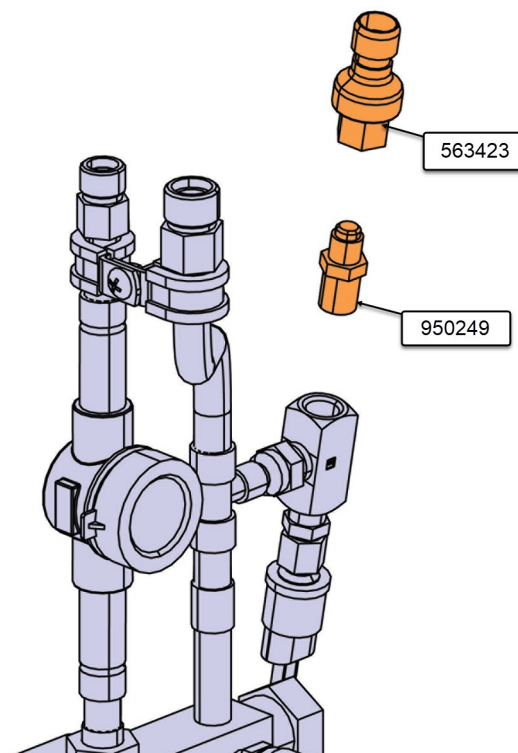

3. Modified the dryer, add adapter 501338, valve 950249 and Pressure switch assembly 950270. Reinstall pressure transducer 563423 and valve 950249.

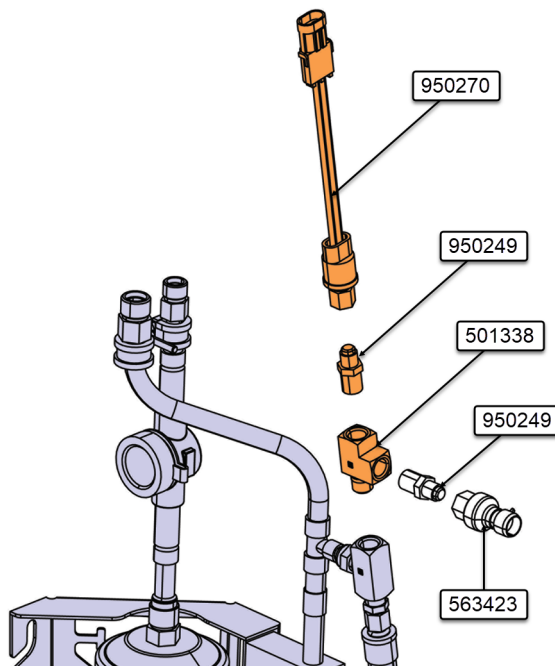

4. Fixe the dryer assembly on the vertical post using bolt 502780 (2x) and washer 5001868 (2x).
5. Install clamp 952629 using bolt 500266.

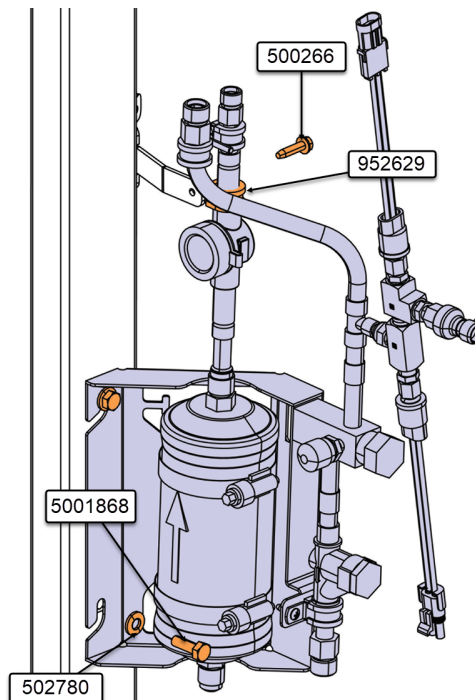

G. HOSE INSTALLATION

Hose overview:

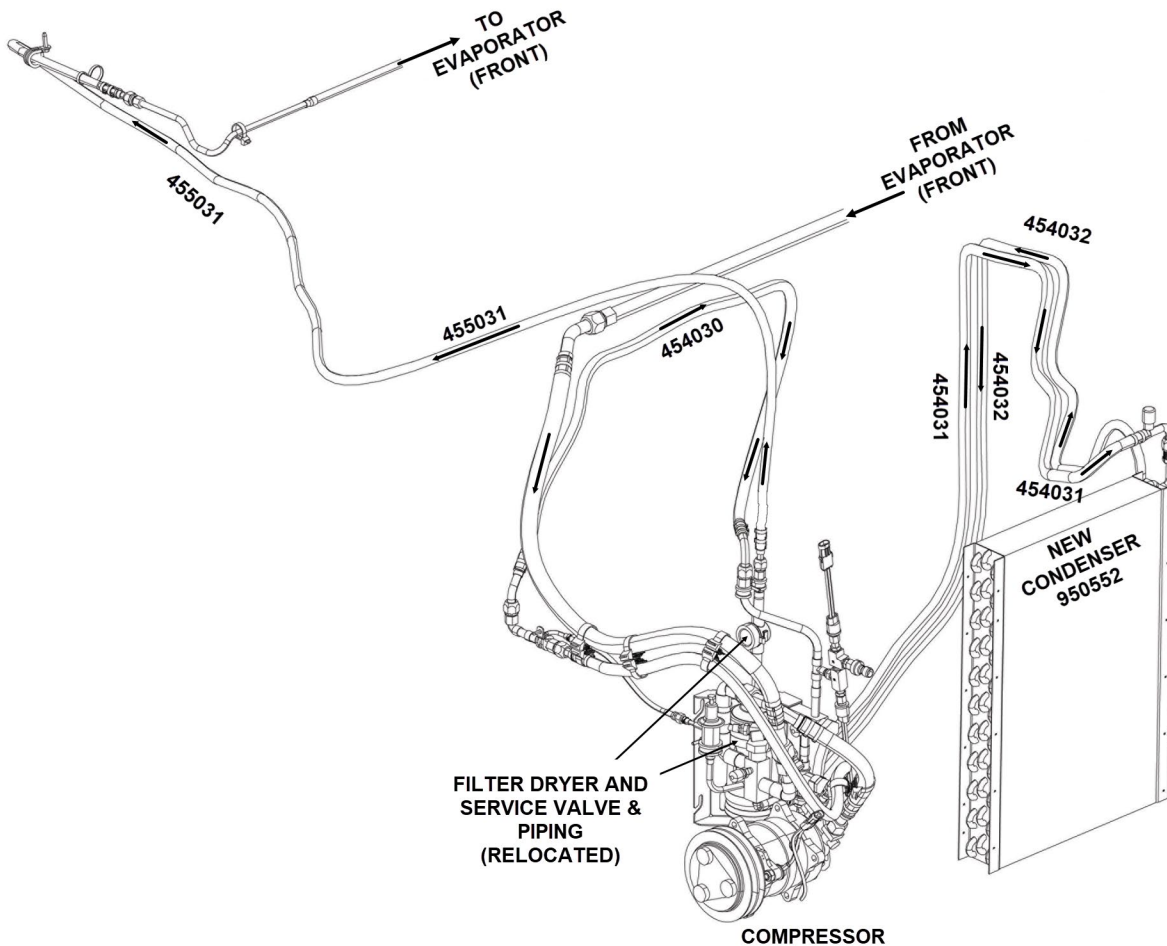

1. Install hose 454030.

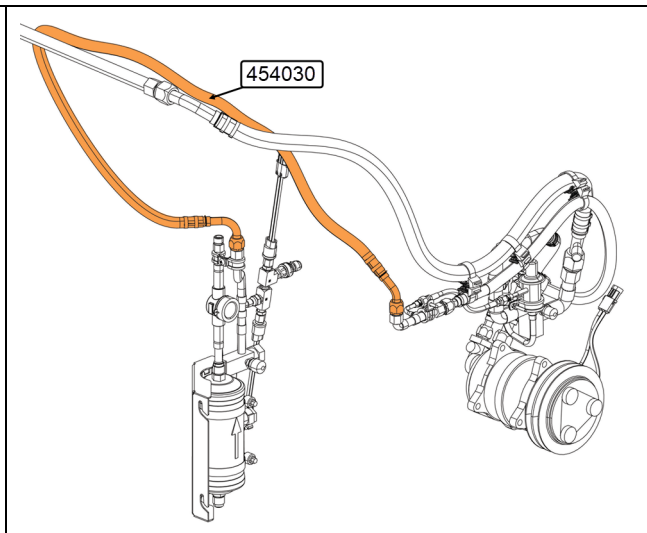

2. Install hose 454031.

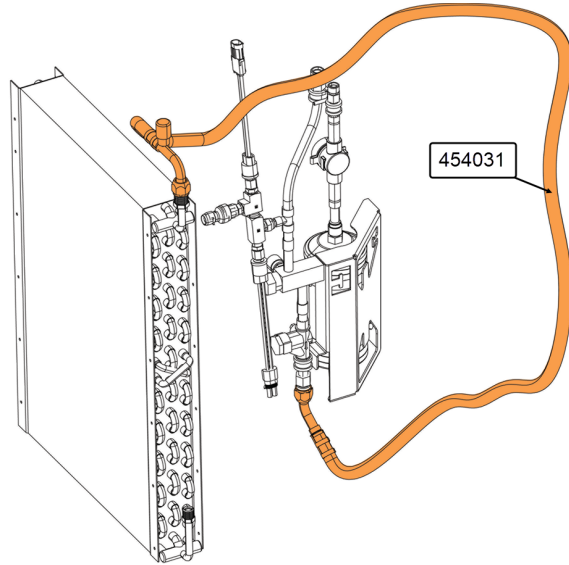

3. Install hose 454032.

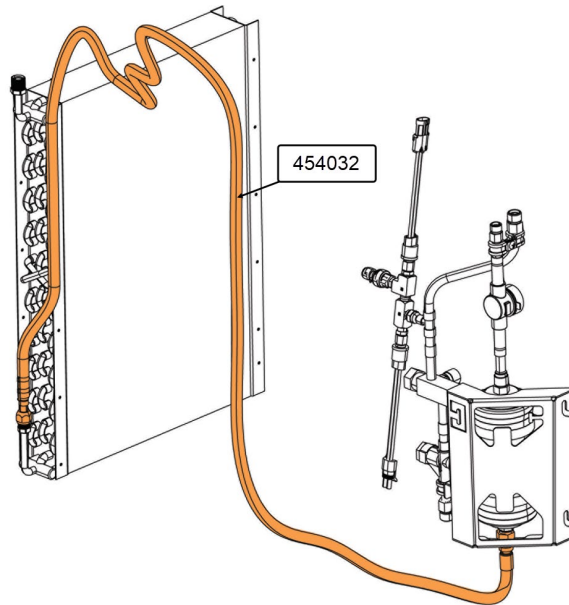

4. Install hose 455031.

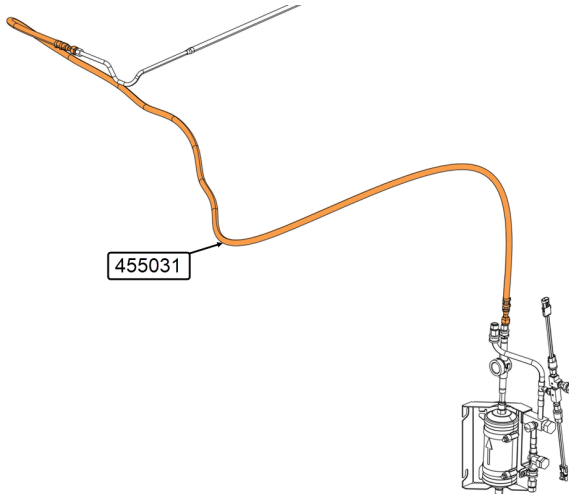

H. HOSE FIXATION

Hose fixation overview:

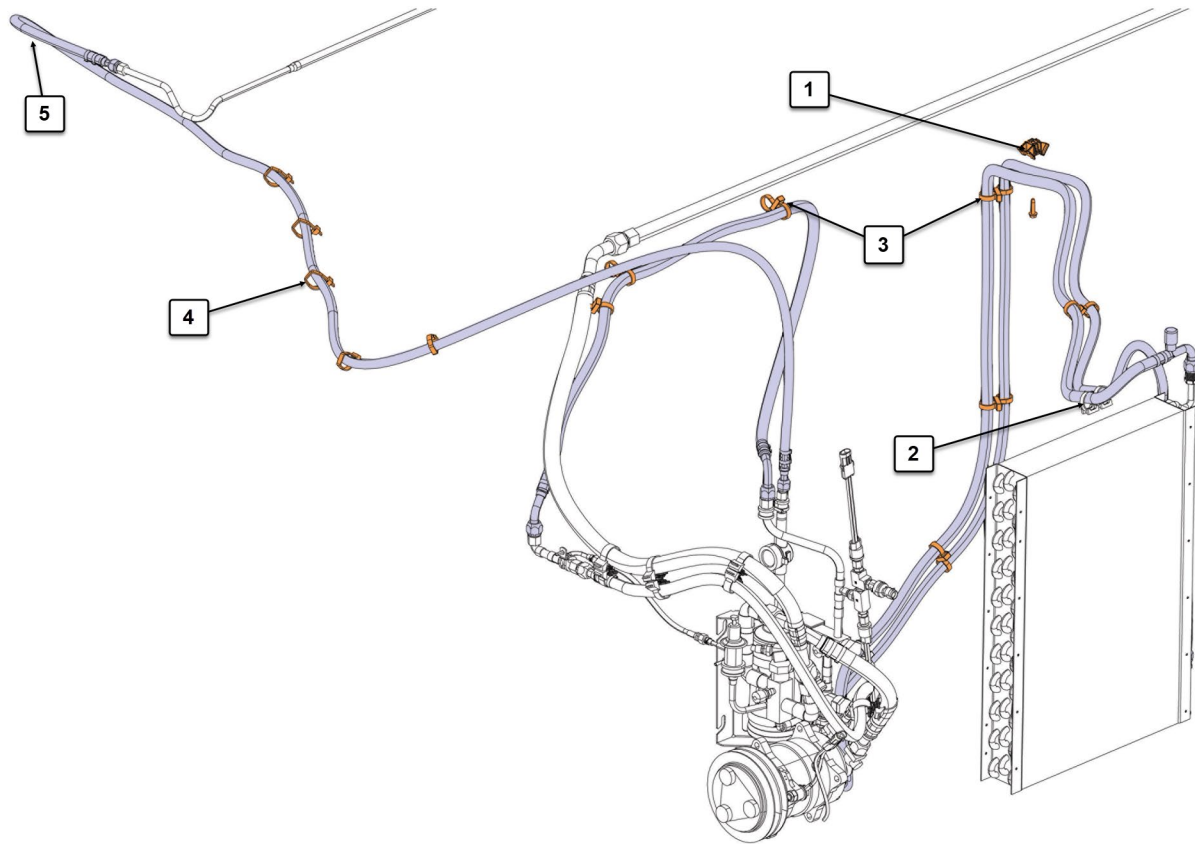

CAUTION

Never attach any hose to harness

1. Fix hoses 454031 and 454032 to the top of the compressor compartment using two-way saddle mounts 509490 with bolt 500266.

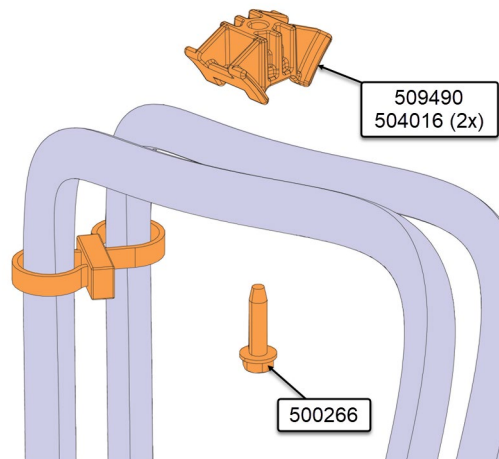

2. Fix hoses 454031 and 454032 to condenser assembly using cable ties 504016 and clamp 952629 (2x).

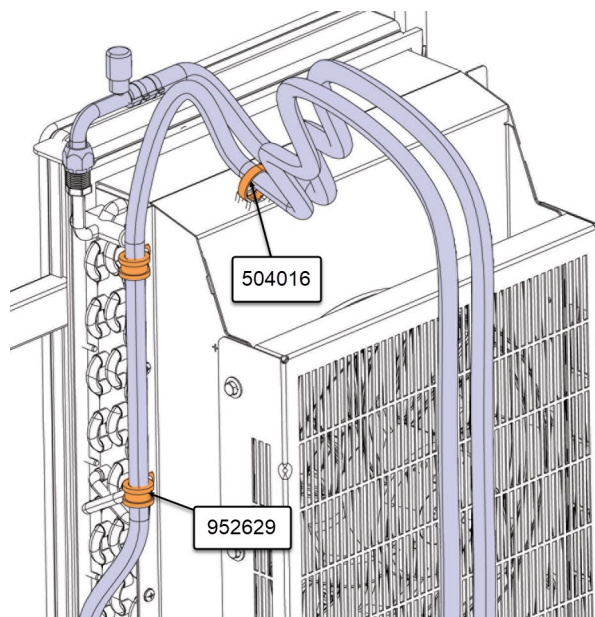

3. Secure all new hoses with double loop cable tie 504768 (15x).

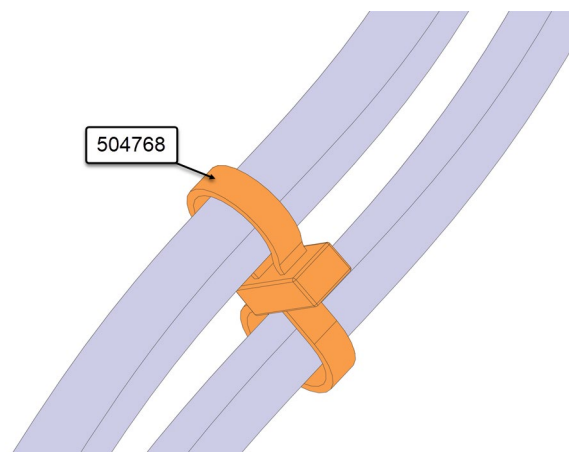

4. Fix hose 455031 using cable ties 504016 (10x) using the same routing of the older hose.

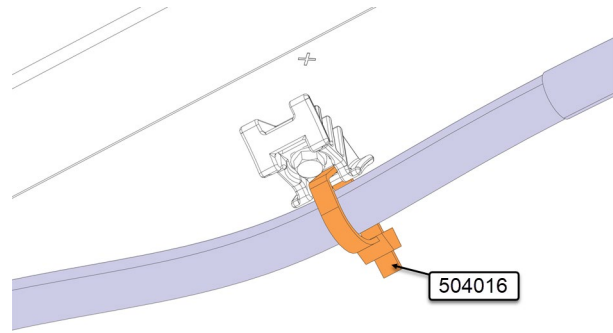

5. Fix hose 455031 using clamp 952631 with bolt 500266.

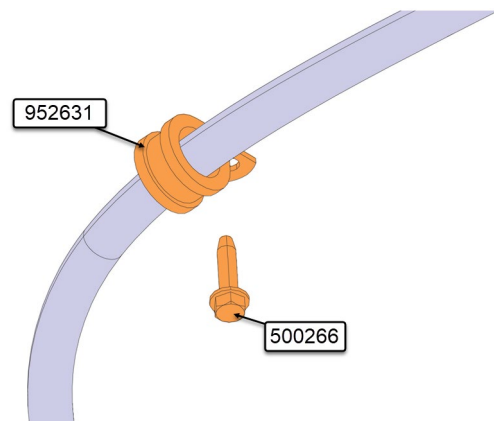

6. Fill air conditioner fluid.

I. POWER STEERING TANK INSTALLATION

Only vehicle with slide-out reinforcement

1. Reinstall the tank using the nut 502837 (2x).

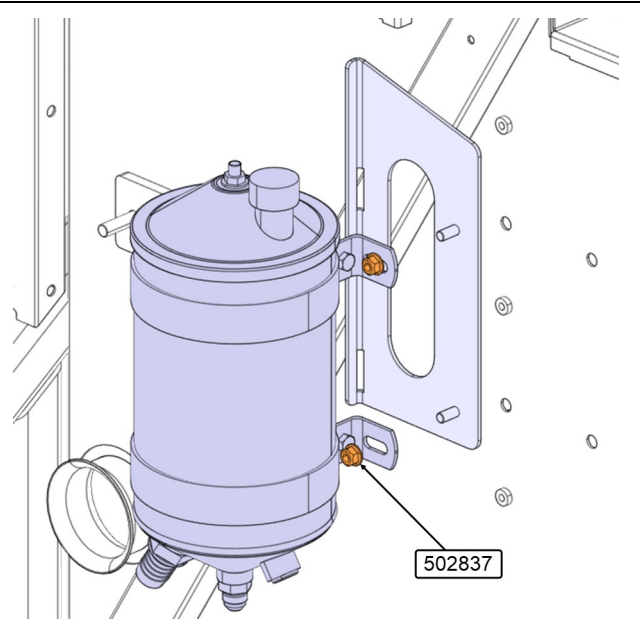

2. Fix hoses 454031 and 454032 to condenser assembly using cable ties 504016 and clamp 952629 (2x).

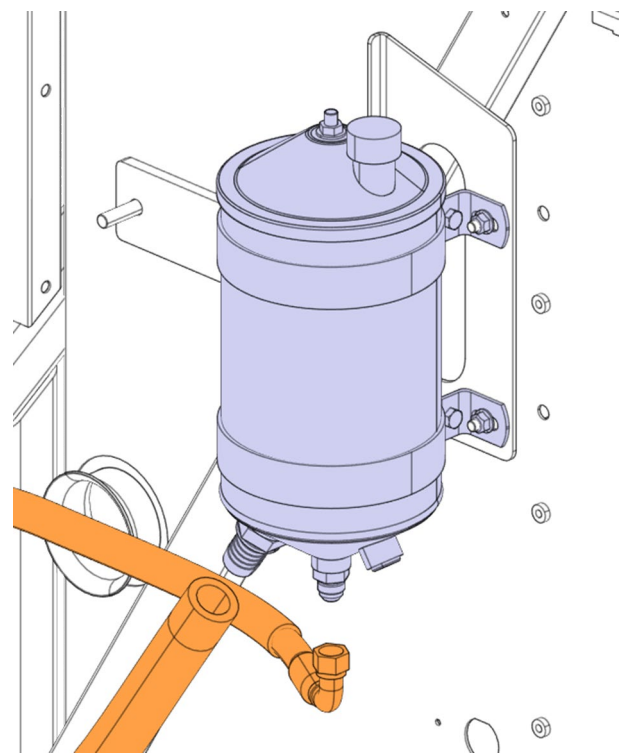

3. Fill the tank with recommended oil.

J. WIRING HARNESS INSTALLATION

Wiring schematic

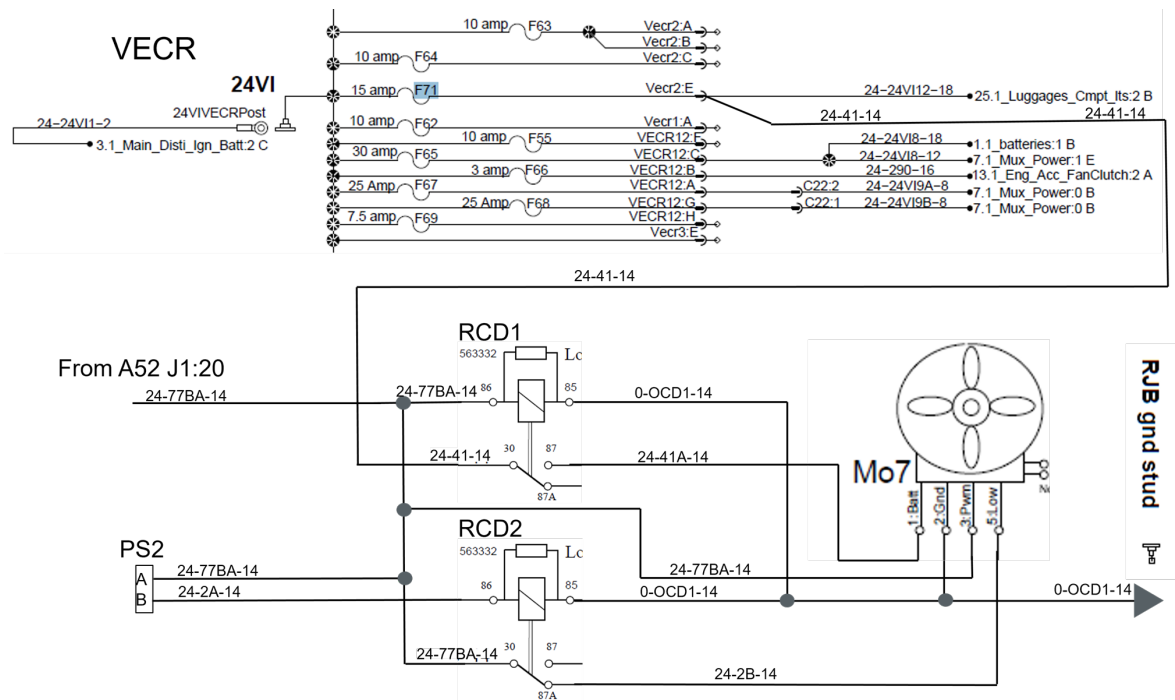

1. Install harness 0610379 using cable tie 504637 (30x).
2. Fixe relay base with 502868 (2x).
3. Install relay 563332 (2x).



4. Fix ground OCD1 to ground stud (beside the start relay).

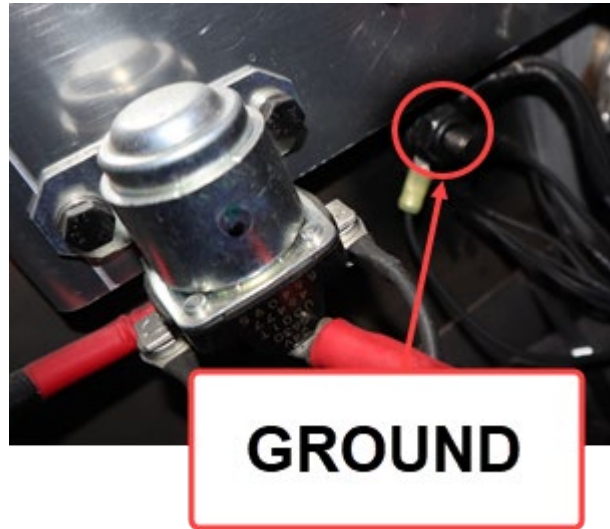

5. Splice wire 77AB with wire at A52 J1:20.



6. Crimp together wires 41 (Lamp wire and harness 0610379) using terminal 562101.



7. Plug fan condenser Mo7 .
8. Use cable tie 504637 (2x) to fix connector to fan shroud.



9. Plug pressure switch 950270 PS2.

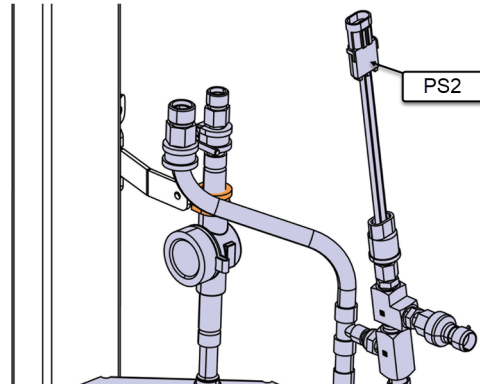

K. VPG: PARAMETER SETTING

Vehicle ID#: **Messages: *** Other version of programs available *****
 RECOMMENDATION: Generate and Transfer the Multiplex program!
 Vehicle generic program has changed since last generation!

General | Vehicle Parameters | Program Generation | Transfer to the Vehicle | Vehicle History |

Vehicle Info

VIN #:	2PCC33494FC735807	Vehicle Type:	MTH XL2 45E	Software ID as shown in the Vehicle MCD
Sales Order:	0004046183 000010	Statut:	In Service	MID 188 SW ID
Production Order:	000007017979	Production Date:	2014/10/24	70403450P02*06100061 P43*00155807A14*

Vehicle Events Data

	Current Data	Last Generation	Last Transfer
User name:	Jean Ruel (Service Rep.)	MLO Service (Garage Miraloma)	MLO Service (Garage Miraloma)
Date/hour:	2020/01/17 15:49:44	2019/10/14 11:17:55	2019/10/14 08:38:55
Parameters:	00155807 Rev:A15	00155807 Rev:A15	00155807 Rev:A14
Program/Date:	06100061 Rev:P44 2020-01-16	06100061 Rev:P43 2017-10-03	06100061 Rev:P43 2017-10-03

Description: Added parameter (EFDSAC) for aftermarket EFD option on Small A/C equipped vehicles. Parameter disables cooling request from A/C system to radiator fans.
 Function 06200295 updated to P07
 Function 06200367 updated to P12

Vehicle ID#: **Messages: *** Other version of programs available *****
 RECOMMENDATION: Generate and Transfer the Multiplex program!
 Vehicle generic program has changed since last generation!

General | Vehicle Parameters | Program Generation | Transfer to the Vehicle | Vehicle History |

Compare parameter values between and

Vehicle Parameters

Para	Description	S	Default Value	Previous Value	Current Value	New Value
EFDSAC	Aftermarket EFD Kit on Small AC eq	N	Without			With

PARTS / WASTE DISPOSAL

Discard waste according to applicable environmental regulations (Municipal/State[Prov.]/ Federal)

Appendix A

STEEL – STEEL WELDING

Caution: Before welding, disconnect electronic modules and battery terminals.

Warning: Welding surfaces must be free of scale, slag, rust, paint, grease, humidity or other foreign material that would render welding impossible.

Warning: Only a qualified and experienced person must do welding.

- FCAW (Flux Cored Arc Welding) process ;
- Electrode wire conforms to A5.20 AWS (American Welding Society) specifications ;
- E4801T-9-CH, type electrode wire with 0,045" diameter (1,14 mm) ;

Material Thickness	Voltage	Current	Wire Feed Rate	Shielding Gas
1/8" to 1/2"	26 ± 2 volts	260 Amps	450 ipm. approx.	75% argon – 25% CO2 or 100% CO2

If necessary and with great care to prevent perforating the material, it is possible to use a conventional electric arc welding machine according to the following specifications:

- SMAW (Shielded Metal-Arc Welding) process ;
- Welding rod conforms to A5.1 of AWS (American Welding Society) specifications; E 7018 type welding rod with 1/8" diameter (3,2 mm).
- Current: 100 amperes to 150 amperes; optimum at 120 amps.

It is important to grind weld bead starts and stops and also to grind arc strikes from surfaces.

STEEL - STAINLESS STEEL OR STAINLESS STEEL - STAINLESS STEEL WELDING

Caution: Before welding, disconnect electronic modules and battery terminals.

Warning: Welding surfaces must be free of scale, slag, rust, paint, grease, humidity or other foreign material that would render welding impossible.

Warning: Only a qualified and experienced person must do welding.

- GMAW (Gas Metal-Arc Welding) process;
- Welding wire conforms to AWS (American Welding Standards) A5.9 specifications;
- 308LSi type welding wire with 0.035" diameter (0,9 mm);

STEEL - STAINLESS STEEL WELDING

Steel Thickness	SS Thickness	Voltage	Current	Wire Feed Rate	Shielding Gas
Less than 1/8"	Any type	20±1.5 volts	130±15 Amps	290 ipm approx.	90% He, 7.5% Ar, 2.5% CO2
1/8" and more	Any type	22±1.5 volts	160±15 Amps	330 ipm approx.	90% He, 7.5% Ar, 2.5% CO2

STAINLESS STEEL - STAINLESS STEEL WELDING

SS Thickness	Voltage	Current	Wire Feed Rate	Shielding Gas
Any type	20 ± 1.5 volts	130 ± 15 Amps	290 ipm approx.	90% He – 7.5% Ar, 2.5% CO ₂

If necessary and with great care to prevent perforating the material, it is possible to use a conventional electric arc welding machine according to the following specifications:

- SMAW (Shield Metal-Arc Welding) process;
- Welding rod conforms to AWS (American Welding Standards) A5.4 specifications; 308L-17 type welding rod with 3/32" diameter (2,4 mm);
- Current: - 50 amperes to 90 amperes, optimum at 60 amperes.

It is important to grind weld bead starts and stops and also to grind arc strikes from surfaces.
