

PREVOST

Instruction Sheet

IS-24901

SIDE CAMERA REARVIEW SYSTEM INSTALLATION X3-45VIP FROM N-6724 & X3-45 COACH FROM M-6658







First Release







11-28-2024



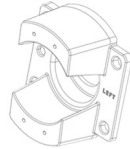
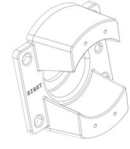

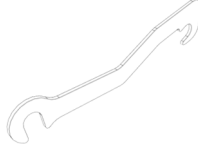
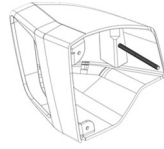
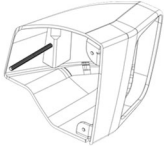

MATERIAL

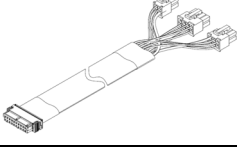
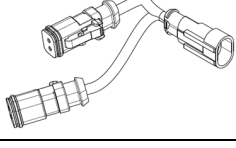

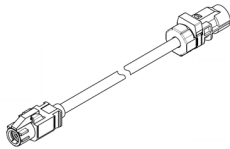
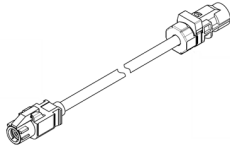
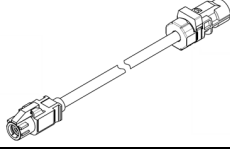
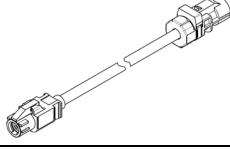

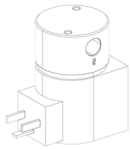
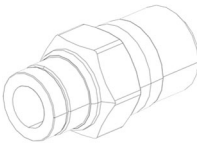
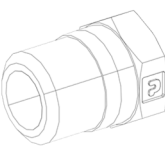

Before starting installations, check if the vehicle was delivered with or without the “READY” option.
If the vehicle without the option you need to replace the windshield center post, see section A.



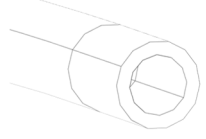
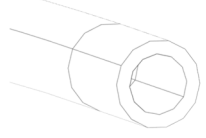
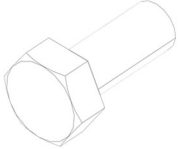
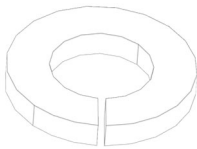

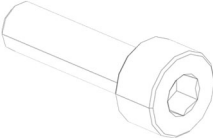

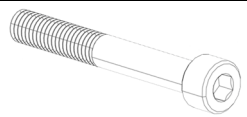
Kit # **492249 (X3-45VIP without ready option)** includes the following parts:





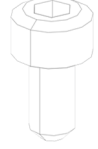
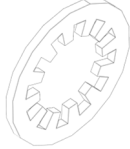
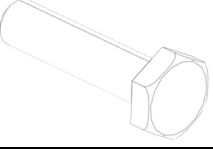

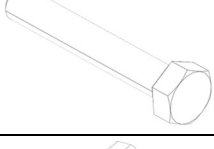
| Part No | Description | Qty |
|---------|---|-----|
| 290985 | CENTRAL POST  | 1 |
| 0610559 | ELECTRONIC MIRROR HARNESS | 1 |
| 901812 | CAMERA LEFT E-MIRROR  | 1 |
| 901814 | CAMERA RIGHT E-MIRROR  | 1 |
| 901912 | MONITOR 12.3  | 2 |
| 402297 | BRACKET INSIDE LEFT  | 1 |
| 402355 | BRACKET INSIDE RIGHT  | 1 |
| 491971 | PLATE, ANGULAR ADJUSTMENT  | 2 |

| | | | |
|--------|-----------------------------|---|---|
| 491986 | BRACKET OUTSIDE LEFT |  | 1 |
| 491981 | BRACKET OUTSIDE RIGHT |  | 1 |
| 420110 | COVER SEAL |  | 2 |
| 492178 | SPACER |  | 4 |
| 420121 | COVER LEFT |  | 1 |
| 420122 | COVER RIGHT |  | 1 |
| 406811 | CENTER FIXATION |  | 1 |
| 406813 | LEFT-HAND FIXATION ASSEMBLY |  | 1 |
| 403848 | SCREEN SUPPORT ASSEMBLY |  | 2 |
| 901897 | POWER CABLE 2M |  | 2 |
| 901901 | CABLE HEATER |  | 2 |





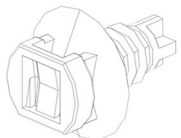
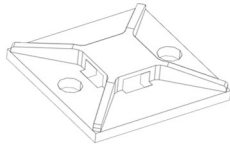

| | | | |
|--------|---|---|---|
| 901816 | CABLE VIDEO BLACK 2M |  | 1 |
| 901817 | CABLE VIDEO WHITE 2M |  | 1 |
| 901895 | CABLE VIDEO WHITE 4M |  | 1 |
| 901896 | CABLE VIDEO BLACK 4M |  | 1 |
| 140374 | SUPPORT SOLENOID |  | 1 |
| 562804 | VALVE SOLENOID 24 VOLTS |  | 1 |
| 641332 | MALE CONNECTOR / #4x1/4NPT-M BR |  | 1 |
| 501312 | BUSHING REDUCER / 1/4NTP-Mx1/8NPT-F BR |  | 1 |
| 642127 | MALE ELBOW 90° DUAL PORT #4X#4X1/8NPT-M |  | 1 |
| 641028 | FEMALE CONNECTOR / #4x1/4NPT-F BR |  | 2 |
| 640058 | MALE BRANCH "Y" / 4MMx4MMx1/4NPT-M |  | 2 |





| | | | |
|---------|---------------------------------------|---|----|
| 140041 | TUBE PNEUMATIC BLACK 1/4 OD X 10300MM |  | 1 |
| 145038 | TUBE PNEUMATIC BLACK 4MM OD X 350MM |  | 4 |
| 5001594 | SCREW CAP HEX SS M8X20 |  | 5 |
| 5001161 | WASHER LOCK SPLIT SS 8.1X14.8X2 |  | 5 |
| 500381 | WASHER FLAT N500 8.4X24X2 |  | 13 |
| 504379 | RIVET POP DOME SS OE 3/16 |  | 1 |
| 5002174 | SCREW CAP HEXS Z050 M4X0.7 X 14MM FT |  | 16 |
| 5002031 | WASHER FLAT SS NSS 4.3X12X1 |  | 14 |
| 5002173 | SCREW CAP HEXS SS M8-1.25X60 |  | 8 |
| 5001341 | WASHER FLAT SS 8.4X16X1.6 |  | 8 |
| 5002205 | WASHER FLAT RUB .29X.688X.09 |  | 8 |



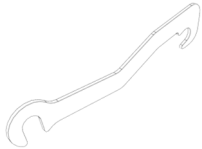
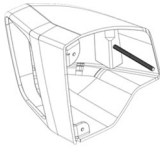
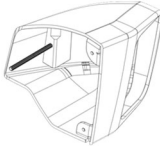

| | | | |
|---------|---------------------------------------|---|----|
| 5001983 | NUT HEX NYRT SS NSS M8X1.25 |  | 10 |
| 502751 | SCREW MACHINE HEX Z050 10-32X3/8 |  | 2 |
| 5001670 | SCREW CAP HEXS M4-0.7 X 8MM FT Z050 |  | 2 |
| 502622 | SCREW CAP HEX SS NSS M6X20 FT |  | 4 |
| 5001432 | WASHER LOCK INT SS .256X.478X.028 |  | 4 |
| 5001433 | SCREW CAP HEX SS M6X25 FT |  | 2 |
| 502853 | WASHER LOCK SPLIT N500 6.1X11.8X1.6 |  | 2 |
| 5001976 | WASHER FLAT SS .266X.718X.056 |  | 2 |
| 5000353 | SCREW CAP BUT HEXS N500 M6-1X12 |  | 8 |
| 502927 | SCREW CAP HEX N500 M8-1.25X50 G8.8 FT |  | 2 |
| 500684 | NUT SPRING U Z050 8A .025-.064 |  | 4 |

| | | | |
|----------|---------------------------------|---|----|
| 509916 | SCREW TP PAN PH N050 #8x3 1/2" |  | 4 |
| 500804 | WASHER FLAT N500 .219X.500X.049 |  | 4 |
| 5001182 | NUT HEX NYRT SS M6-1 |  | 2 |
| 502573 | WASHER FLAT SS 6.4X 12.0X 1.6 |  | 2 |
| 5002214 | WASHER FLAT RUB .23X.625X.09 |  | 2 |
| 504637 | CABLE TIE, NYLON BLACK (STD) |  | 34 |
| 509815 | FIR TREE MOUNTING (FT7 TYPE) |  | 1 |
| 562679 | 4 WAY ADH. SQUARE BACKED MOUNTS |  | 16 |
| IS-24901 | INSTRUCTION SHEET | | 1 |
| FI-24901 | FEUILLE D'INSTRUCTION | | 1 |

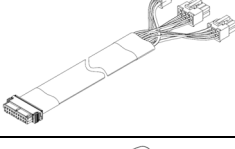
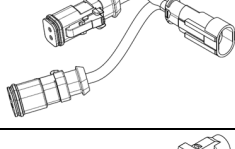
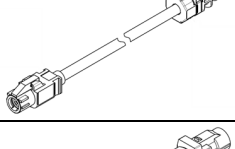
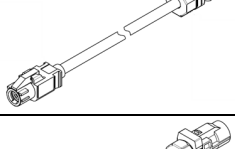
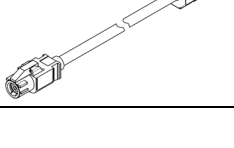

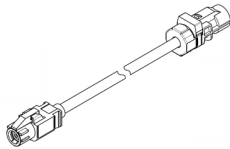
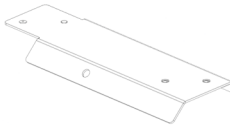
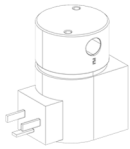
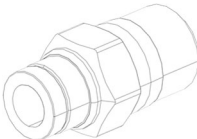
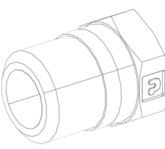



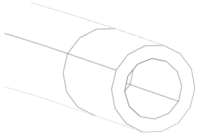
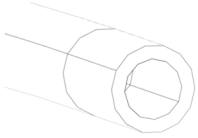
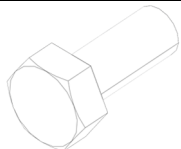

Kit # 492132 (X3-45 coach without ready option) includes the following parts:

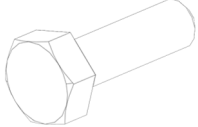

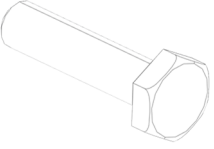
| Part No | Description | Qty |
|---------|---|-----|
| 290985 | CENTRAL POST  | 1 |
| 0610480 | ELECTRONIC MIRROR HARNESS | 1 |
| 901812 | CAMERA LEFT E-MIRROR  | 1 |
| 901814 | CAMERA RIGHT E-MIRROR  | 1 |
| 901982 | MONITOR 12.3  | 2 |
| 402297 | BRACKET INSIDE LEFT  | 1 |
| 402355 | BRACKET INSIDE RIGHT  | 1 |
| 491971 | PLATE, ANGULAR ADJUSTMENT  | 2 |
| 491986 | BRACKET OUTSIDE LEFT  | 1 |
| 491981 | BRACKET OUTSIDE RIGHT  | 1 |
| 420110 | COVER SEAL  | 2 |

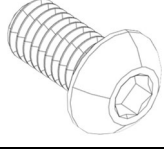
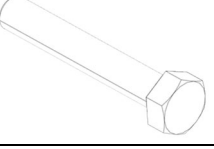
| | | | |
|--------|-----------------------------|---|---|
| 492178 | SPACER |  | 4 |
| 420121 | COVER LEFT |  | 1 |
| 420122 | COVER RIGHT |  | 1 |
| 406811 | CENTER FIXATION |  | 1 |
| 406813 | LEFT-HAND FIXATION ASSEMBLY |  | 1 |
| 403848 | SCREEN SUPPORT ASSEMBLY |  | 2 |
| 901897 | POWER CABLE 2M |  | 2 |
| 901901 | CABLE HEATER |  | 2 |
| 901816 | CABLE VIDEO BLACK 2M |  | 1 |
| 901817 | CABLE VIDEO WHITE 2M |  | 1 |
| 901895 | CABLE VIDEO WHITE 4M |  | 1 |







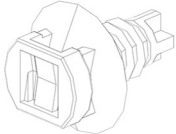
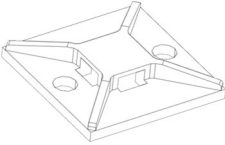



| | | | |
|---------|---|---|---|
| 901896 | CABLE VIDEO BLACK 4M |  | 1 |
| 140374 | SUPPORT SOLENOID |  | 1 |
| 562804 | VALVE SOLENOID 24 VOLTS |  | 1 |
| 641332 | MALE CONNECTOR / #4x1/4NPT-M BR |  | 1 |
| 501312 | BUSHING REDUCER / 1/4NTP-Mx1/8NPT-F BR |  | 1 |
| 642127 | MALE ELBOW 90° DUAL PORT #4X#4X1/8NPT-M |  | 1 |
| 641028 | FEMALE CONNECTOR / #4x1/4NPT-F BR |  | 2 |
| 640058 | MALE BRANCH "Y" / 4MMx4MMx1/4NPT-M |  | 2 |
| 140041 | TUBE PNEUMATIC BLACK 1/4 OD X 10300MM |  | 1 |
| 145038 | TUBE PNEUMATIC BLACK 4MM OD X 350MM |  | 4 |
| 5001594 | SCREW CAP HEX SS M8X20 |  | 5 |





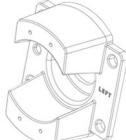

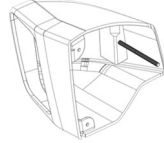

| | | | |
|---------|--------------------------------------|---|----|
| 5001161 | WASHER LOCK SPLIT SS 8.1X14.8X2 |  | 5 |
| 500381 | WASHER FLAT N500 8.4X24X2 |  | 13 |
| 504379 | RIVET POP DOME SS OE 3/16 |  | 1 |
| 5002174 | SCREW CAP HEXS Z050 M4X0.7 X 14MM FT |  | 16 |
| 5002031 | WASHER FLAT SS NSS 4.3X12X1 |  | 14 |
| 5002173 | SCREW CAP HEXS SS M8-1.25X60 |  | 8 |
| 5001341 | WASHER FLAT SS 8.4X16X1.6 |  | 8 |
| 5002205 | WASHER FLAT RUB .29X.688X.09 |  | 8 |
| 5001983 | NUT HEX NYRT SS NSS M8X1.25 |  | 10 |
| 502751 | SCREW MACHINE HEX Z050 10-32X3/8 |  | 2 |
| 5001670 | SCREW CAP HEXS M4-0.7 X 8MM FT Z050 |  | 2 |

| | | | |
|---------|---------------------------------------|---|---|
| 502622 | SCREW CAP HEX SS NSS M6X20 FT |  | 4 |
| 5001432 | WASHER LOCK INT SS .256X.478X.028 |  | 4 |
| 5001433 | SCREW CAP HEX SS M6X25 FT |  | 2 |
| 502853 | WASHER LOCK SPLIT N500 6.1X11.8X1.6 |  | 2 |
| 5001976 | WASHER FLAT SS .266X.718X.056 |  | 2 |
| 5000353 | SCREW CAP BUT HEXS N500 M6-1X12 |  | 8 |
| 502927 | SCREW CAP HEX N500 M8-1.25X50 G8.8 FT |  | 2 |
| 500684 | NUT SPRING U Z050 8A .025-.064 |  | 4 |
| 509916 | SCREW TP PAN PH N050 #8x3 1/2" |  | 4 |
| 500804 | WASHER FLAT N500 .219X.500X.049 |  | 4 |
| 5001182 | NUT HEX NYRT SS M6-1 |  | 2 |



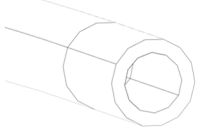
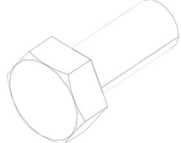



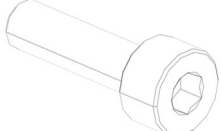

| | | | |
|----------|---------------------------------|---|----|
| 502573 | WASHER FLAT SS 6.4X12.0X 1.6 |  | 2 |
| 5002214 | WASHER FLAT RUB .23X.625X.09 |  | 2 |
| 504637 | CABLE TIE, NYLON BLACK (STD) |  | 34 |
| 509815 | FIR TREE MOUNTING (FT7 TYPE) |  | 1 |
| 562679 | 4 WAY ADH. SQUARE BACKED MOUNTS |  | 16 |
| IS-24901 | INSTRUCTION SHEET | | 1 |
| FI-24901 | FEUILLE D'INSTRUCTION | | 1 |

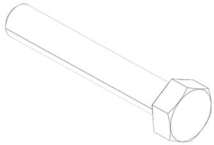
Kit # 492248 (X3-45VIP with ready option) includes the following parts:







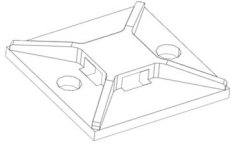



| Part No | Description | Qty |
|---------|---|-----|
| 901812 | CAMERA LEFT E-MIRROR  | 1 |
| 901814 | CAMERA RIGHT E-MIRROR  | 1 |
| 901912 | MONITOR 12.3  | 1 |
| 402297 | BRACKET INSIDE LEFT  | 1 |
| 402355 | BRACKET INSIDE RIGHT  | 1 |
| 491971 | PLATE, ANGULAR ADJUSTMENT  | 2 |
| 491986 | BRACKET OUTSIDE LEFT  | 1 |
| 491981 | BRACKET OUTSIDE RIGHT  | 1 |
| 420110 | COVER SEAL  | 2 |
| 492178 | SPACER  | 4 |





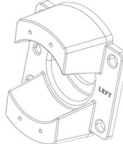



| | | | |
|---------|--------------------------------------|---|----|
| 420121 | COVER LEFT |  | 1 |
| 420122 | COVER RIGHT |  | 1 |
| 406811 | CENTER FIXATION |  | 1 |
| 406813 | LEFT-HAND FIXATION ASSEMBLY |  | 1 |
| 403848 | SCREEN SUPPORT ASSEMBLY |  | 2 |
| 145038 | TUBE PNEUMATIC BLACK 4MM OD X 350MM |  | 4 |
| 5001594 | SCREW CAP HEX SS M8X20 |  | 5 |
| 5001161 | WASHER LOCK SPLIT SS 8.1X14.8X2 |  | 5 |
| 500381 | WASHER FLAT N500 8.4X24X2 |  | 13 |
| 504379 | RIVET POP DOME SS OE 3/16 |  | 1 |
| 5002174 | SCREW CAP HEXS Z050 M4X0.7 X 14MM FT |  | 16 |

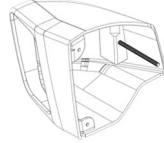

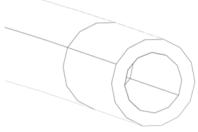
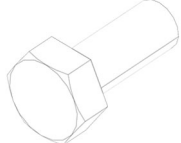

| | | | |
|---------|-------------------------------------|---|----|
| 5002031 | WASHER FLAT SS NSS 4.3X12X1 |  | 10 |
| 5002173 | SCREW CAP HEXS SS M8-1.25X60 |  | 8 |
| 5001341 | WASHER FLAT SS 8.4X16X1.6 |  | 8 |
| 5002205 | WASHER FLAT RUB .29X.688X.09 |  | 8 |
| 5001983 | NUT HEX NYRT SS NSS M8X1.25 |  | 10 |
| 502622 | SCREW CAP HEX SS NSS M6X20 FT |  | 4 |
| 5001432 | WASHER LOCK INT SS .256X.478X.028 |  | 4 |
| 5001433 | SCREW CAP HEX SS M6X25 FT |  | 2 |
| 502853 | WASHER LOCK SPLIT N500 6.1X11.8X1.6 |  | 2 |
| 5001976 | WASHER FLAT SS .266X.718X.056 |  | 2 |
| 5000353 | SCREW CAP BUT HEXS N500 M6-1X12 |  | 8 |



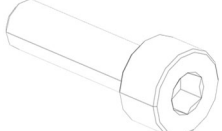

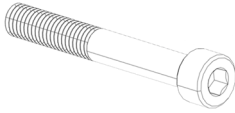

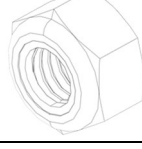
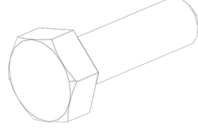

| | | | |
|----------|---------------------------------------|---|----|
| 502927 | SCREW CAP HEX N500 M8-1.25X50 G8.8 FT |  | 2 |
| 500684 | NUT SPRING U Z050 8A .025-.064 |  | 4 |
| 509916 | SCREW TP PAN PH N050 #8x3 1/2" |  | 4 |
| 500804 | WASHER FLAT N500 .219X.500X.049 |  | 4 |
| 5001182 | NUT HEX NYRT SS M6-1 |  | 2 |
| 502573 | WASHER FLAT SS 6.4X12.0X1.6 |  | 2 |
| 5002214 | WASHER FLAT RUB .23X.625X.09 |  | 2 |
| 504637 | CABLE TIE, NYLON BLACK (STD) |  | 16 |
| 562679 | 4 WAY ADH. SQUARE BACKED MOUNTS |  | 16 |
| IS-24901 | INSTRUCTION SHEET | | 1 |
| FI-24901 | FEUILLE D'INSTRUCTION | | 1 |

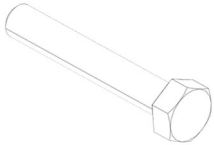
Kit # 492133 (X3-45 coach with ready option) includes the following parts:

| Part No | Description | Qty |
|---------|---|-----|
| 901812 | CAMERA LEFT E-MIRROR  | 1 |
| 901814 | CAMERA RIGHT E-MIRROR  | 1 |
| 901982 | MONITOR 12.3  | 2 |
| 402297 | BRACKET INSIDE LEFT  | 1 |
| 402355 | BRACKET INSIDE RIGHT  | 1 |
| 491971 | PLATE, ANGULAR ADJUSTMENT  | 2 |
| 491986 | BRACKET OUTSIDE LEFT  | 1 |
| 491981 | BRACKET OUTSIDE RIGHT  | 1 |
| 420110 | COVER SEAL  | 2 |
| 492178 | SPACER  | 4 |

| | | | |
|---------|--------------------------------------|---|----|
| 420121 | COVER LEFT |  | 1 |
| 420122 | COVER RIGHT |  | 1 |
| 406811 | CENTER FIXATION |  | 1 |
| 406813 | LEFT-HAND FIXATION ASSEMBLY |  | 1 |
| 403848 | SCREEN SUPPORT ASSEMBLY |  | 2 |
| 145038 | TUBE PNEUMATIC BLACK 4MM OD X 350MM |  | 4 |
| 5001594 | SCREW CAP HEX SS M8X20 |  | 5 |
| 5001161 | WASHER LOCK SPLIT SS 8.1X14.8X2 |  | 5 |
| 500381 | WASHER FLAT N500 8.4X24X2 |  | 13 |
| 504379 | RIVET POP DOME SS OE 3/16 |  | 1 |
| 5002174 | SCREW CAP HEXS Z050 M4X0.7 X 14MM FT |  | 16 |

| | | | |
|---------|-------------------------------------|---|----|
| 5002031 | WASHER FLAT SS NSS 4.3X12X1 |  | 10 |
| 5002173 | SCREW CAP HEXS SS M8-1.25X60 |  | 8 |
| 5001341 | WASHER FLAT SS 8.4X16X1.6 |  | 8 |
| 5002205 | WASHER FLAT RUB .29X.688X.09 |  | 8 |
| 5001983 | NUT HEX NYRT SS NSS M8X1.25 |  | 10 |
| 502622 | SCREW CAP HEX SS NSS M6X20 FT |  | 4 |
| 5001432 | WASHER LOCK INT SS .256X.478X.028 |  | 4 |
| 5001433 | SCREW CAP HEX SS M6X25 FT |  | 2 |
| 502853 | WASHER LOCK SPLIT N500 6.1X11.8X1.6 |  | 2 |
| 5001976 | WASHER FLAT SS .266X.718X.056 |  | 2 |
| 5000353 | SCREW CAP BUT HEXS N500 M6-1X12 |  | 8 |

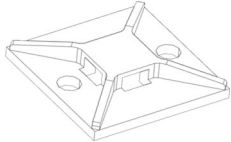
| | | | |
|----------|---------------------------------------|---|----|
| 502927 | SCREW CAP HEX N500 M8-1.25X50 G8.8 FT |  | 2 |
| 500684 | NUT SPRING U Z050 8A .025-.064 |  | 4 |
| 509916 | SCREW TP PAN PH N050 #8x3 1/2" |  | 4 |
| 500804 | WASHER FLAT N500 .219X.500X.049 |  | 4 |
| 5001182 | NUT HEX NYRT SS M6-1 |  | 2 |
| 502573 | WASHER FLAT SS 6.4X12.0X 1.6 |  | 2 |
| 5002214 | WASHER FLAT RUB .23X.625X.09 |  | 2 |
| 504637 | CABLE TIE, NYLON BLACK (STD) |  | 16 |
| 562679 | 4 WAY ADH. SQUARE BACKED MOUNTS |  | 16 |
| IS-24901 | INSTRUCTION SHEET | | 1 |
| FI-24901 | FEUILLE D'INSTRUCTION | | 1 |

Other parts required:

| Part No. | Description | Qty |
|----------|---------------------------|-----|
| 680098 | LOCTITE 567 TEFLON 250 ML | AR |

NOTE

Material can be obtained through regular channels.

SAFETY PRECAUTIONS

- Eye protection should always be worn when working in a shop.
- Rules for Personal Protection Equipment should always be respected. Wear your PPE including but not limited to the following:



Safety First!



PROCEDURE



DANGER

Park vehicle safely, apply parking brake, stop the engine. Prior to working on the vehicle, set the ignition switch to the OFF position and trip the main circuit breakers equipped with a trip button. On Commuter type vehicles, set the battery master switch (master cut-out) to the OFF position.

Lock out & Tag out (LOTO) must be performed during set-up, maintenance or repair activities. Refer to your local procedure for detailed information regarding the control of hazardous energy.

Table of contents

| | |
|--|----|
| A. VERIFICATION OF THE "READY" OPTION..... | 23 |
| B. REMOVE MIRROR AND SUNSHADES..... | 26 |
| C. REMOVE FRONT CAP INTERIOR FINISHING..... | 27 |
| D. REMOVE DASHBOARD FINISHING (without "ready" option)..... | 29 |
| E. MODIFICATION OF THE FRONT CAP..... | 31 |
| F. INSTALLATION OF THE LEFT CAMERA..... | 37 |
| G. INSTALLATION OF THE RIGHT CAMERA..... | 39 |
| H. CONNECT CAMERA (with option READY)..... | 41 |
| I. INSTALLATION OF HARNESES (without option READY)..... | 42 |
| J. INSTALLATION SOLENOID VALVE (without option READY)..... | 48 |
| K. INSTALLATION OF THE PNEUMATIC HOSES (without option READY)..... | 50 |
| L. INSTALLATION OF THE MONITOR SUPPORT..... | 54 |
| M. SECURE THE HARNESES AND THE PNEUMATIC HOSES..... | 55 |
| N. REINSTALL WINDSHIELDS (without option READY)..... | 56 |
| O. REINSTALL DASH COVERS (without option READY)..... | 57 |
| P. REINSTALL FRONT CAP INTERIOR FINISHING..... | 59 |
| Q. REINSTALL MIRROR AND SUNSHADES..... | 62 |
| R. INSTALLATION OF THE MONITORS..... | 63 |
| S. CAMERA ALIGNMENT..... | 66 |
| T. PARAMETER PROGRAMMING WITH VPG SOFTWARE TOOL..... | 71 |

A. VERIFICATION OF THE "READY" OPTION

1. Verify if the pneumatic panel has the solenoid valve and pneumatic hose:
 - If yes, the vehicle is with the "READY" option.
 - If no, the vehicle is without the "READY" option.

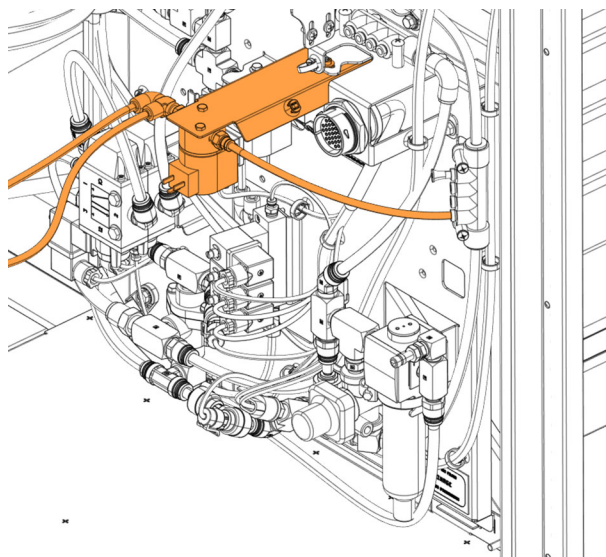

2. Remove the screws (3x) to remove the central pillar cover.

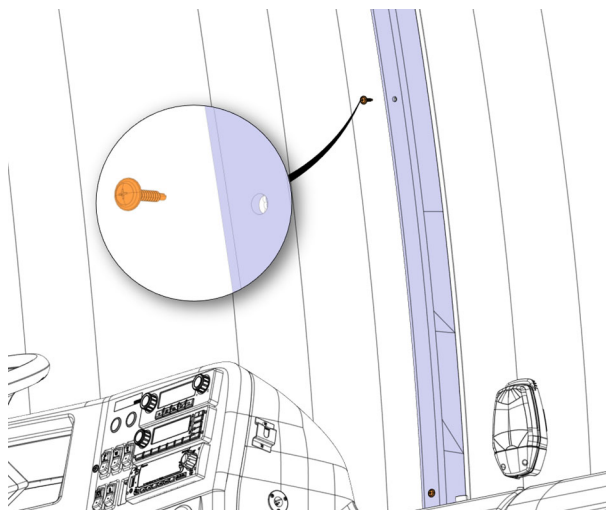

3. Verify if the central post has those nuts insert:
 - If yes, go to section "B".
 - If not go to the next step (2).

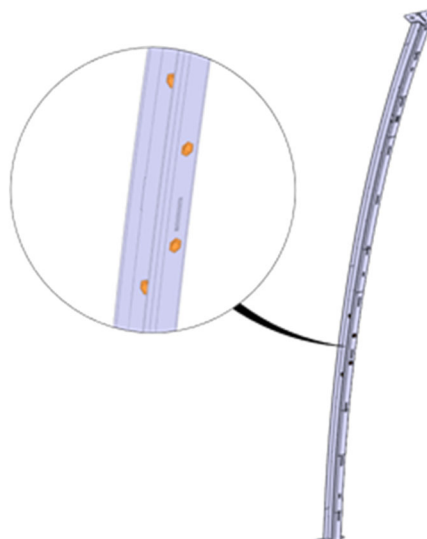

4. Remove the windshields (see maintenance manual).

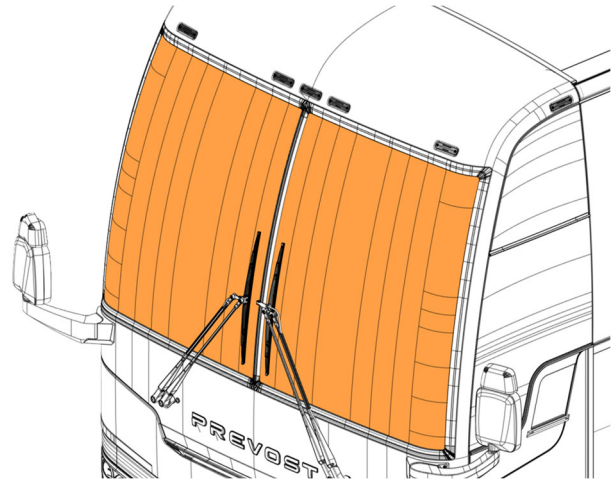

5. Remove the central post and discard keep the hardware to reuse.

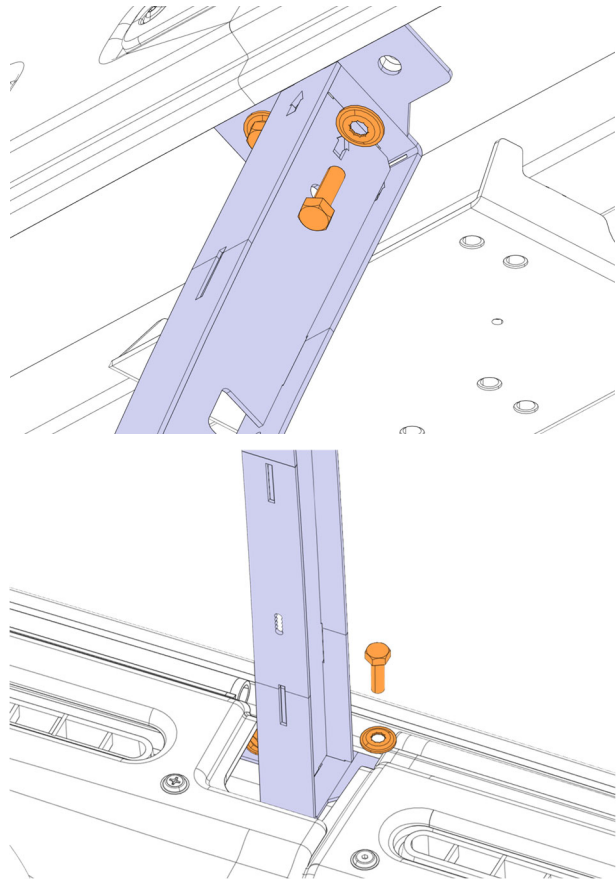

6. Install the new central post 290985 with the screws (4x) and the washers (4x).

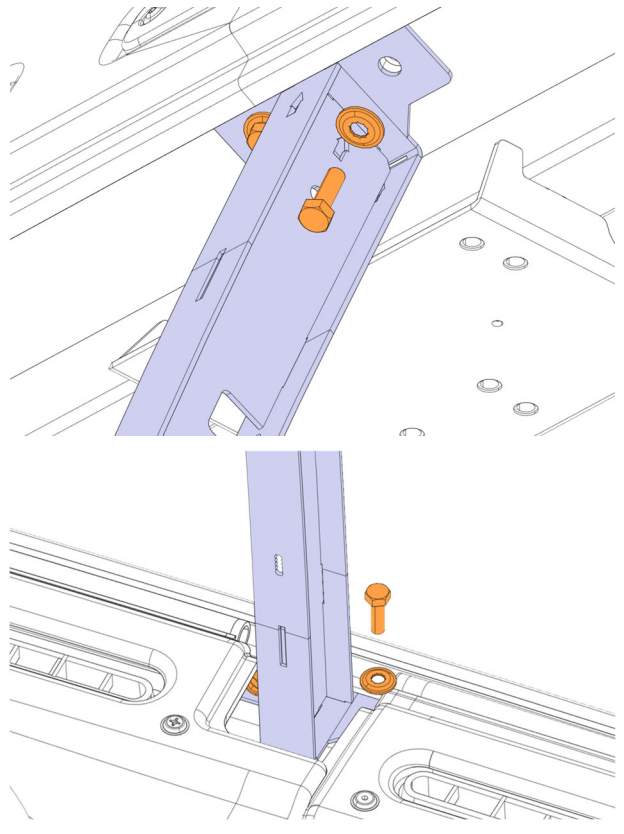

B. REMOVE MIRROR AND SUNSHADES

1. Remove interior mirrors (X3-45 coach only).

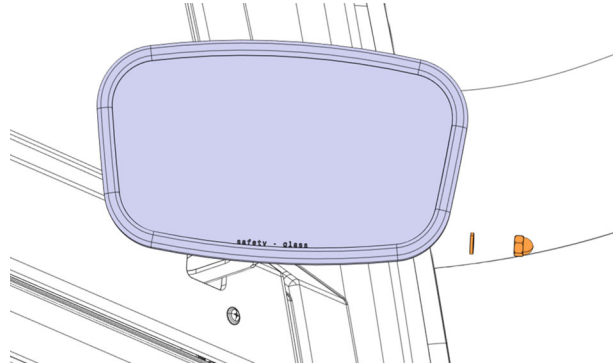

2. Remove front sunshades.

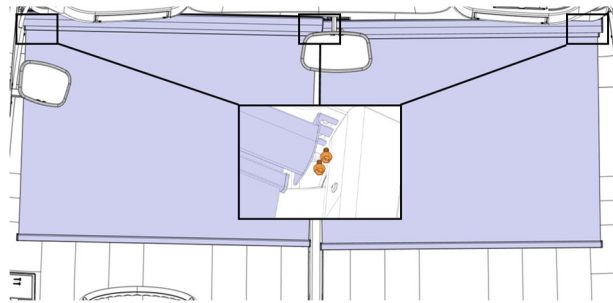

3. Remove the driver's sunshade. (X3-45 coach only).

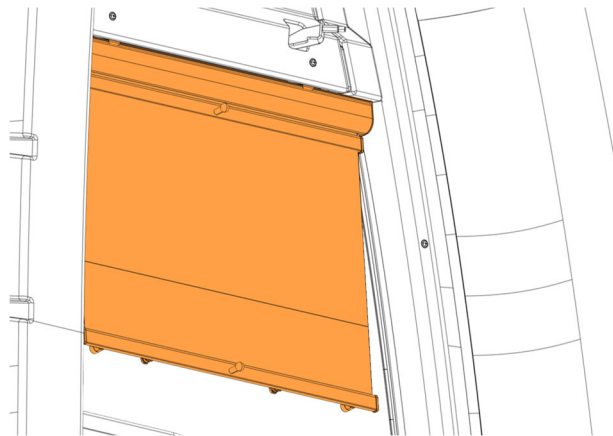

C. REMOVE FRONT CAP INTERIOR FINISHING

1. Remove the screws (2x) to remove the entrance door upper panel.

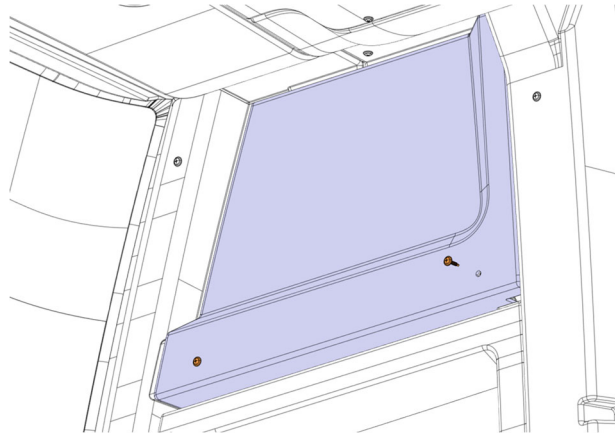

2. Remove the screws (3x) to remove the right pillar cover.

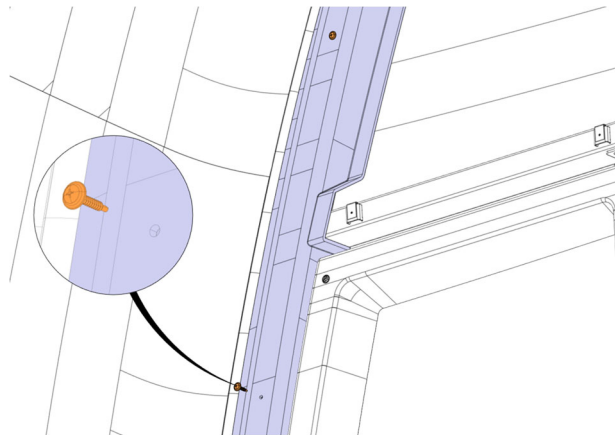

3. Remove the screws (3x) to remove the central pillar cover.

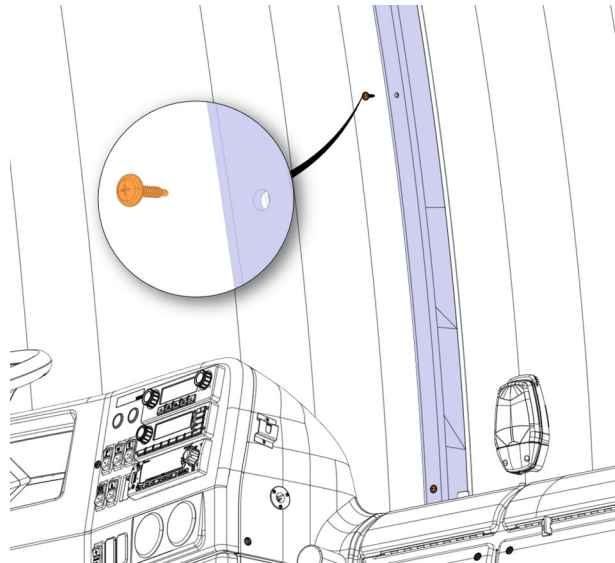

4. Remove the screws (2x) to remove the driver's window upper panel.

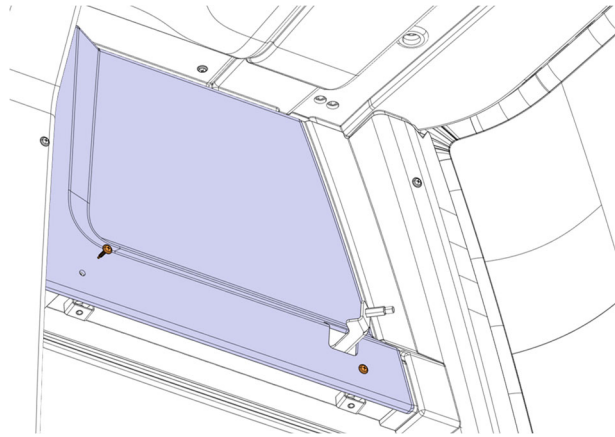

5. Remove mirror support. (X3-45 coach only).

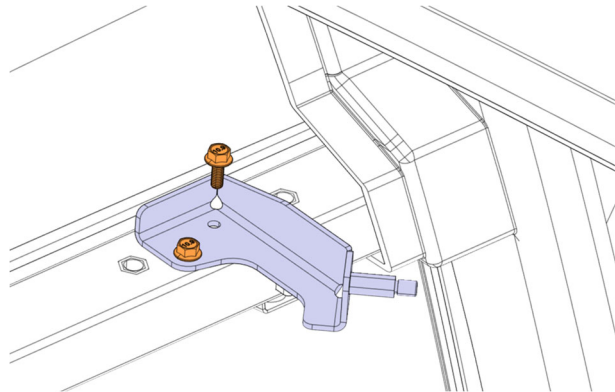

6. Remove the screws (3x) to remove the left pillar cover.

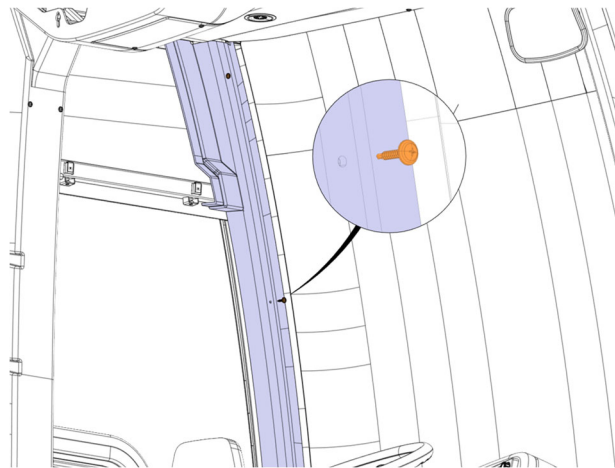

D. REMOVE DASHBOARD FINISHING (without "ready" option)

1. Remove the screws (5x), the washers (5x) to remove the dash cover panel.

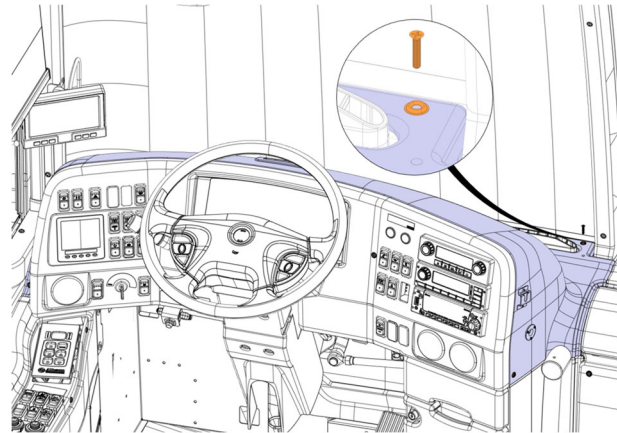

2. Remove the screws (4x), the washers (4x) to remove the defroster access panel.

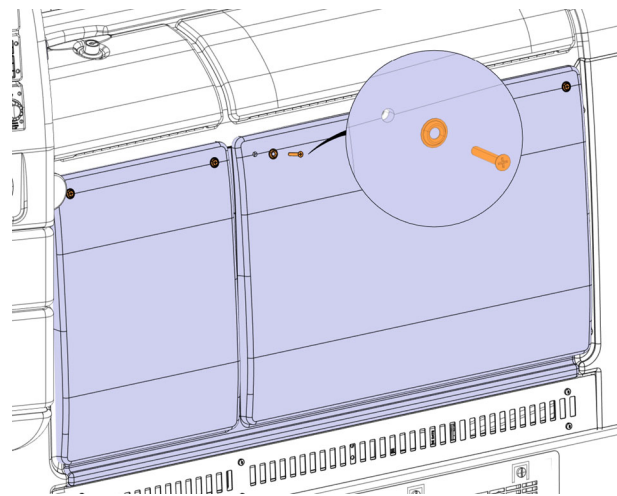

3. Remove the screws (5x), the washers (5x) to remove the entrance door cover mechanism.

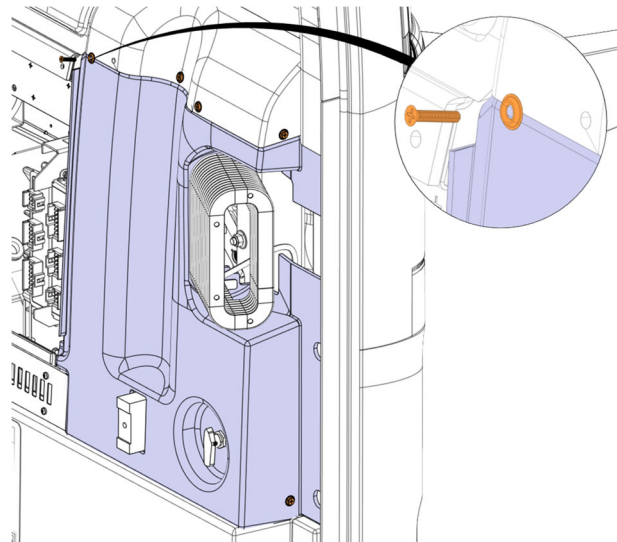

4. Remove the screws (3x), the washers (3x) to remove the top right dash panel.

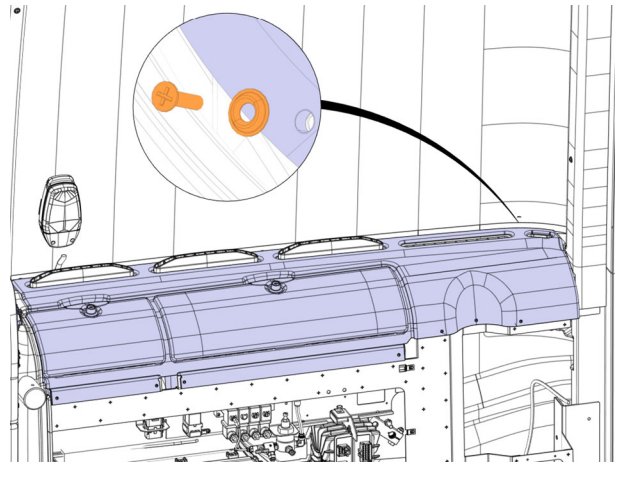

E. MODIFICATION OF THE FRONT CAP

1. To avoid chipping paint, apply masking tape outside of the top-left front cap.

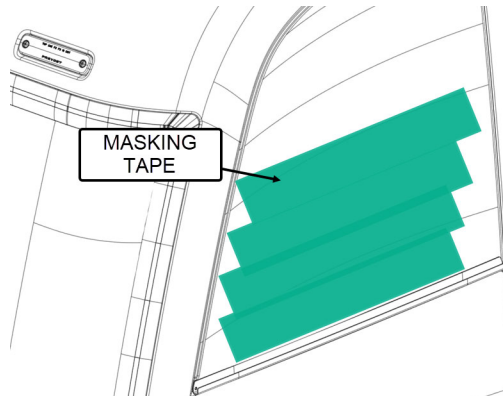

2. Install the support 402297 temporarily with the screws 5001594 (2x), the lock washers 5001161 (2x) and the flat washers 500381 (2x).

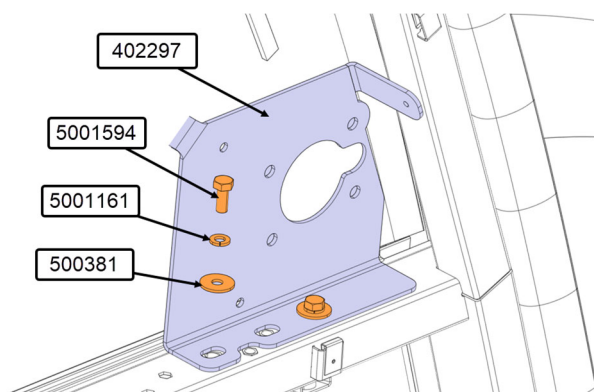

3. Marking the section on the insulation to remove.

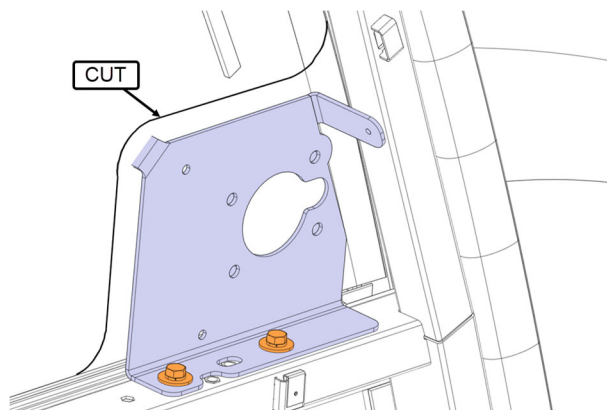

4. Remove the support 402297, the screws 5001594 (2x), the lock washers 5001161 (2x) and the flat washers 500381 (2x).

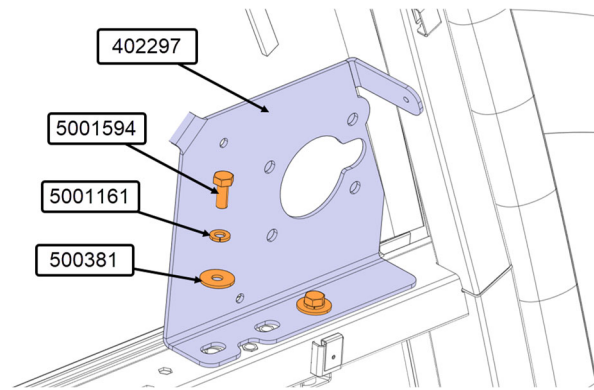

5. Remove the cutout section of the insulation.

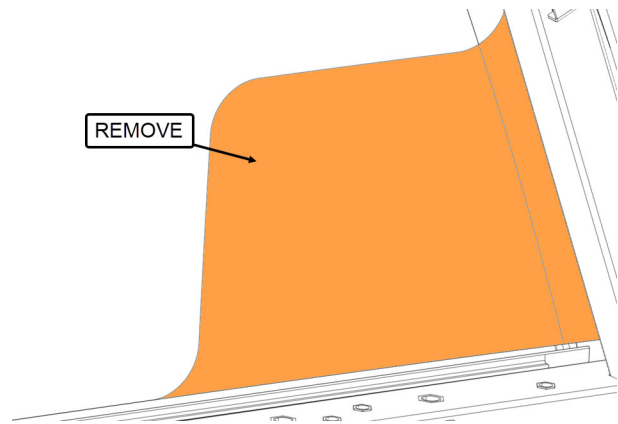

6. Install the support 402297 with the screws 5001594 (2x), the lock washers 5001161 (2x) and the flat washers 500381 (2x).

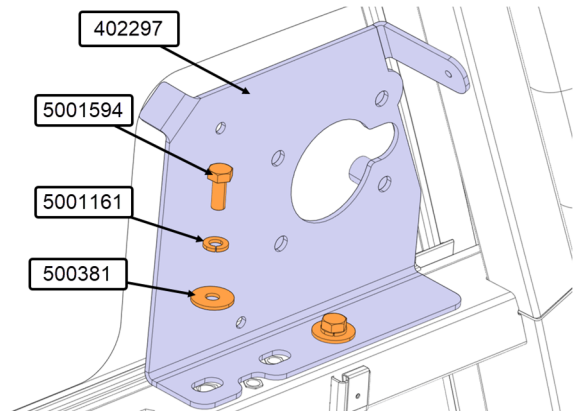

7. Drill a hole $\text{\O} 3/16''$.

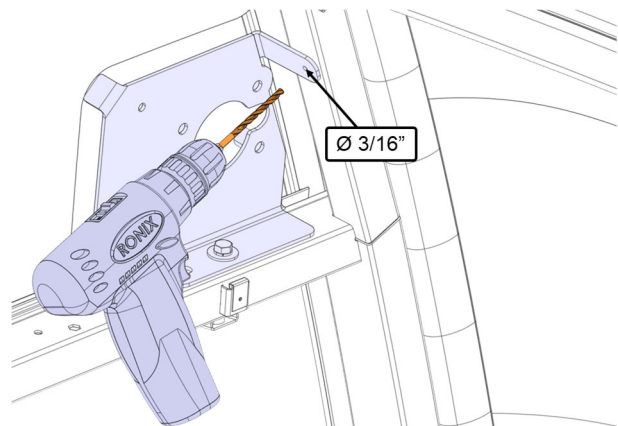

8. Secure the top section of the support 402297 with rivet 504379.

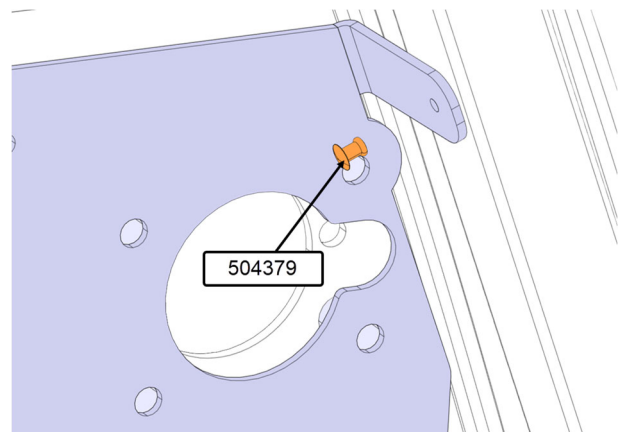

9. Drill four (4) holes \varnothing 3/8".

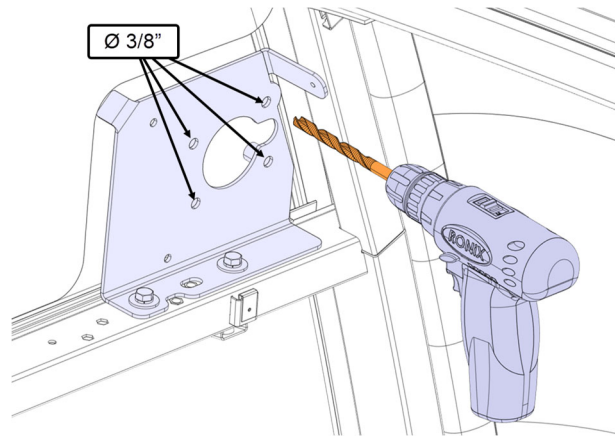

10. Drill two (2) holes \varnothing 19/64".

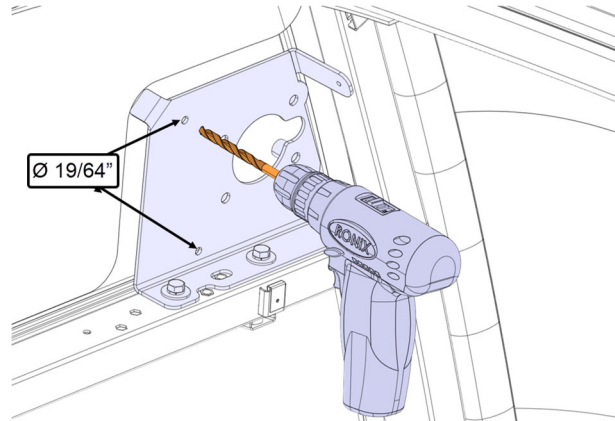

11. From the inside, drill a pilot hole with the hole saw center bit.

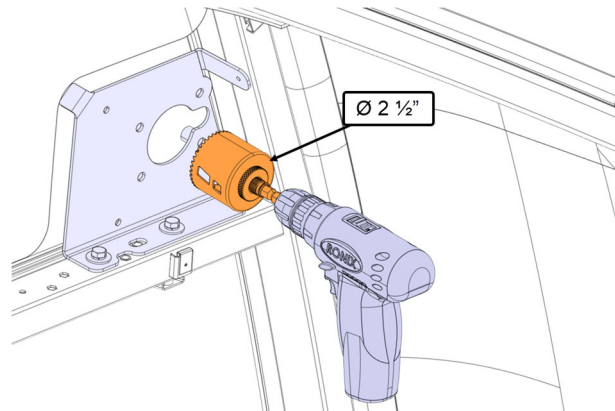

12. From the outside drill a hole \varnothing 2 1/2", use the pilot hole drills previously.

13. Remove masking tape.

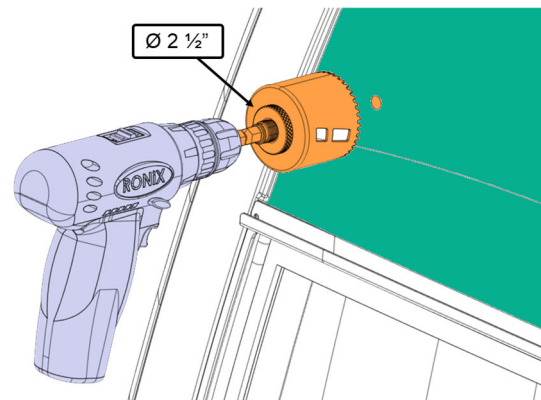

14. To avoid chipping paint, apply masking tape outside of the top right front cap.

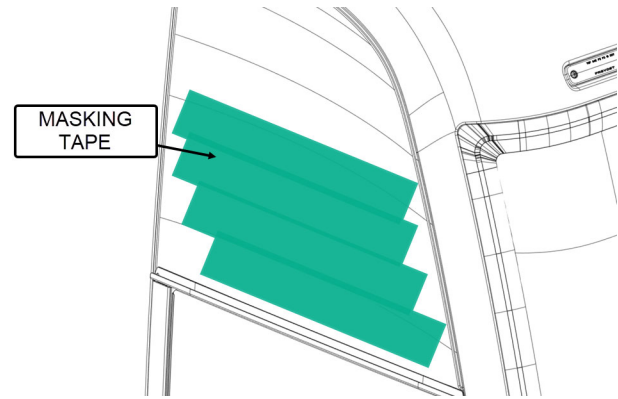

15. Install the support 402355 temporarily with the screws 5001594 (3x), the lock washers 5001161 (3x) and the flat washers 500381 (3x).

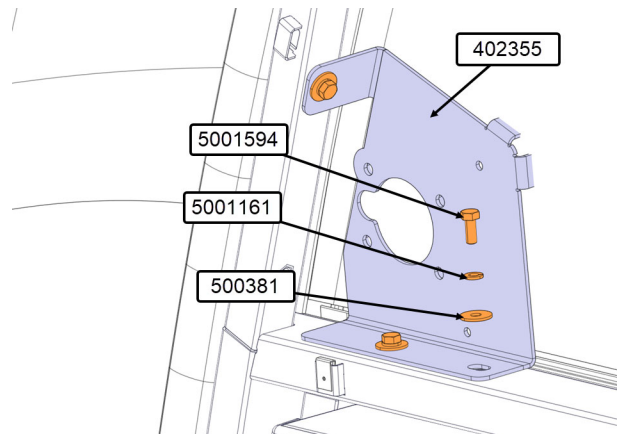

16. Marking the section on the insulation to remove.

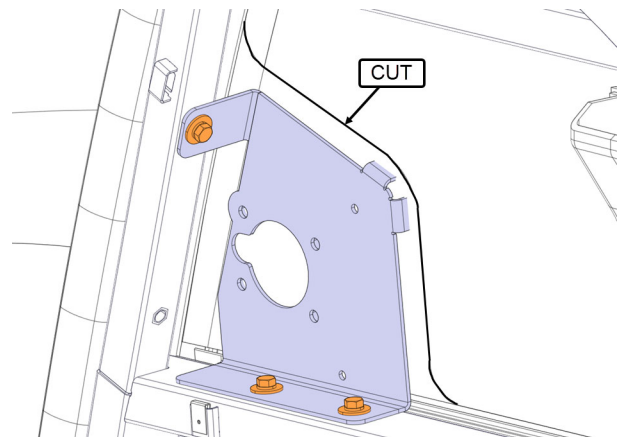

17. Remove the support 402355, the screws 5001594 (3x), the lock washers 5001161 (3x) and the flat washers 500381 (3x).

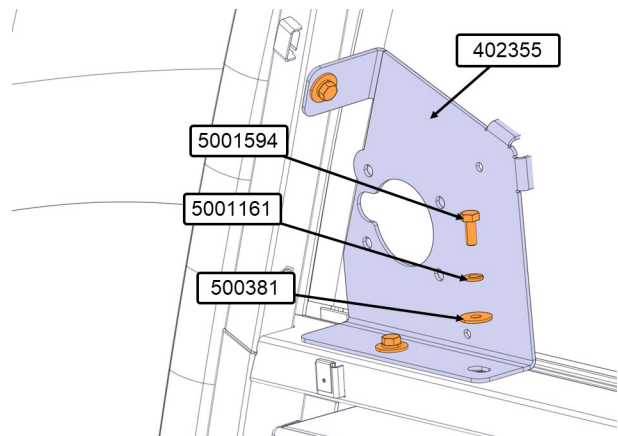

18. Remove the cutout section of the insulation.

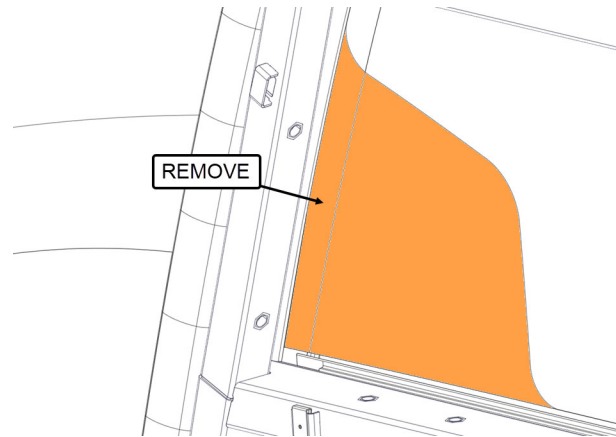

19. Install the support 402355 with the screws 5001594 (3x), the lock washers 5001161 (3x) and the flat washers 500381 (3x).

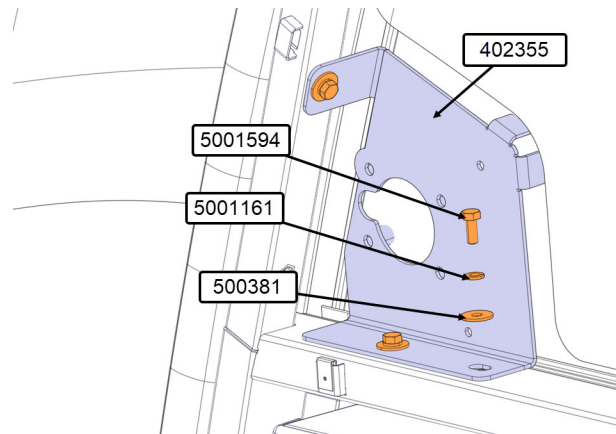

20. Drill four (4) holes $\text{\O} 3/8''$.

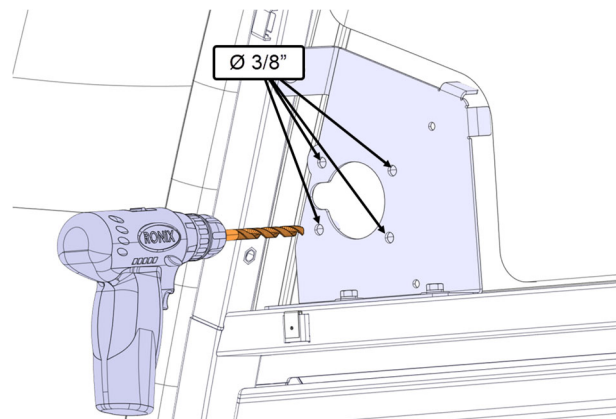

21. Drill two (2) holes $\text{\O} 19/64''$.

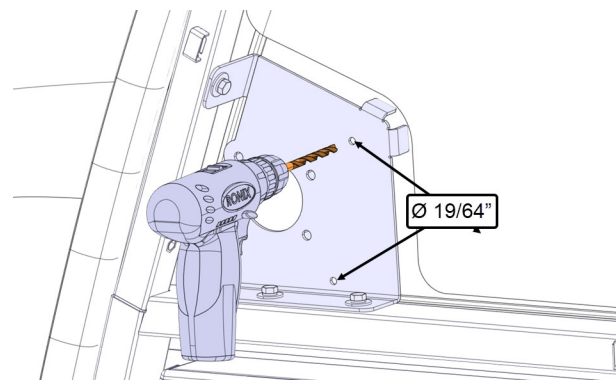

22. From the inside, drill a pilot hole with the hole saw center bit.

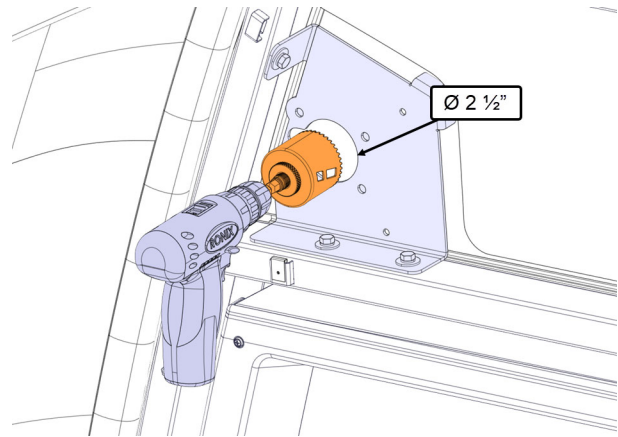

23. From the outside drill a hole $\text{Ø } 2 \frac{1}{2}''$, use the pilot hole drills previously.
24. Remove masking tape.

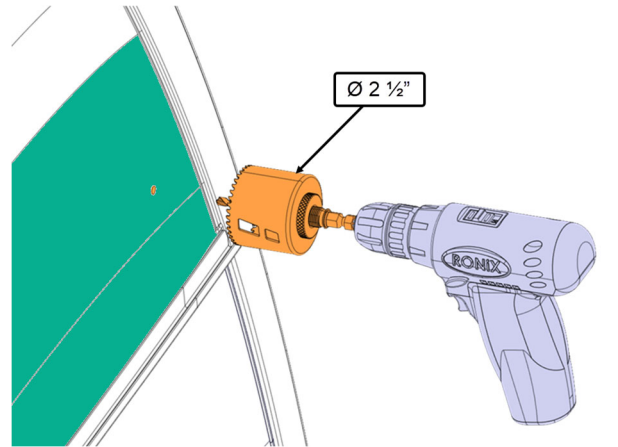

F. INSTALLATION OF THE LEFT CAMERA

1. Install the angular adjustment plate 491971 on the outside bracket 491986 with the screws 5002174 (4x).

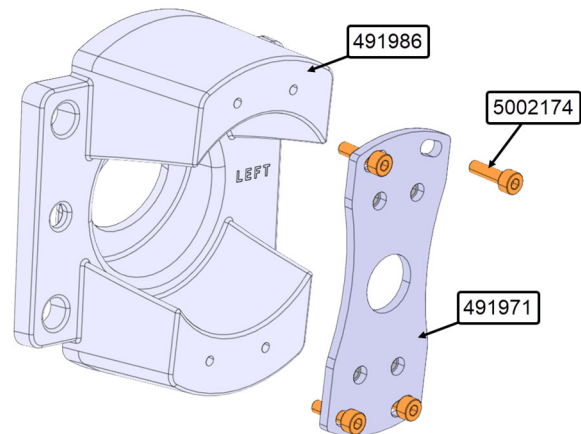

2. Install the camera 901812 on the outside bracket assembly with the screws 5002174 (4x) and the flat washers 5002031 (4x).

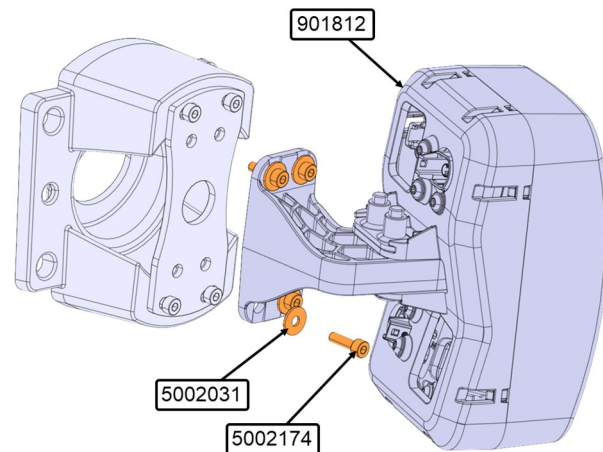

3. Pre-assemble the camera and support on the cover seal 420110. Pre-install the screws 5002173 (4x), the washers 5001341 (4x) and the rubber washers 5002205 (4x)

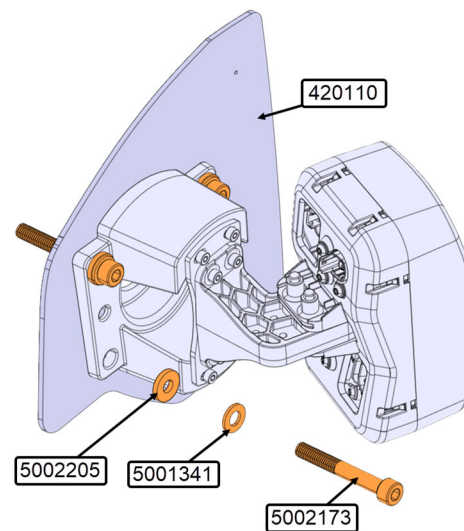

4. Install the left camera pre-assembly on the vehicle.

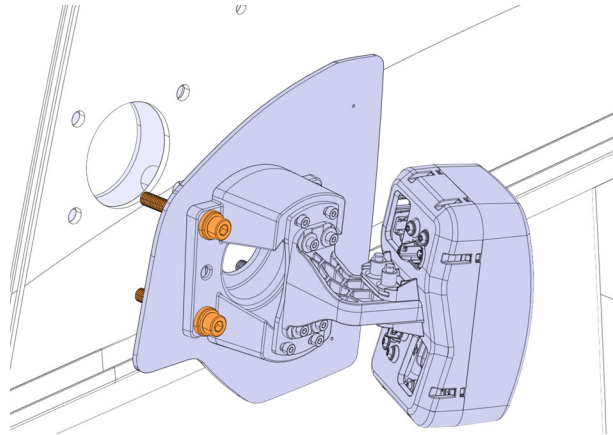

5. Secure the camera with the nuts 5001983 (4x) and the washer 500381 (4x).

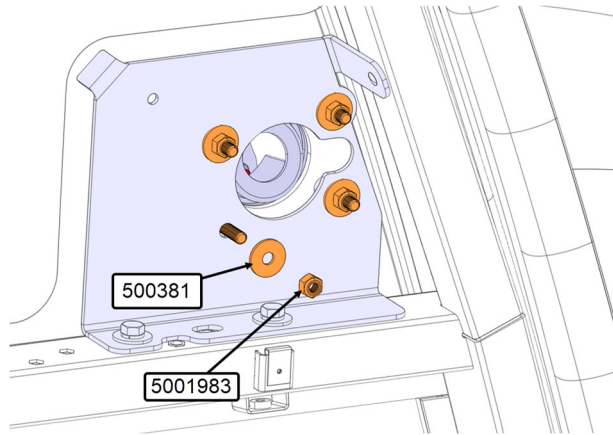

6. Drill one (1) holes $\text{\O} 3/8''$.

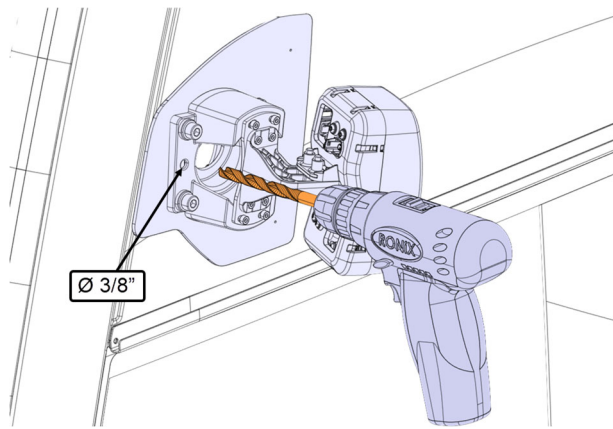

G. INSTALLATION OF THE RIGHT CAMERA

1. Install the angular adjustment plate 491971 on the outside bracket 491981 with the screws 5002174 (4x).

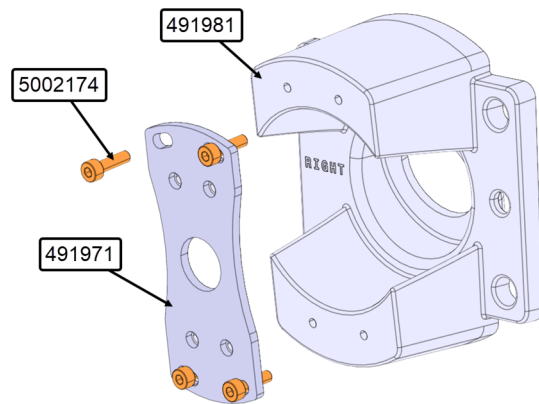

2. Install the camera 901814 on the outside bracket assembly with the screws 5002174 (4x) and the flat washers 5002031 (4x).

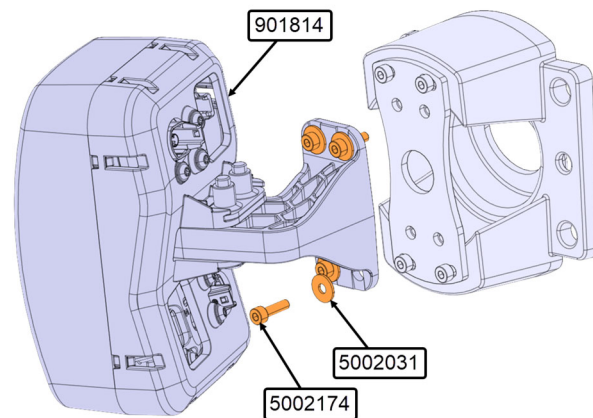

3. Pre-assemble the camera and support on the cover seal 420110. Pre-install the screws 5002173 (4x), the washers 5001341 (4x) and the rubber washers 5002205 (4x).

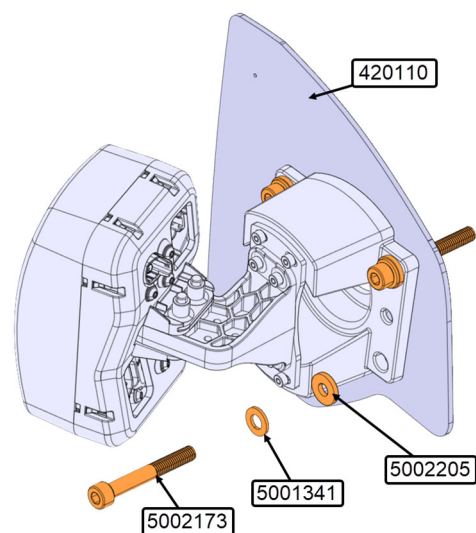

4. Install the right camera pre-assembly on the vehicle.

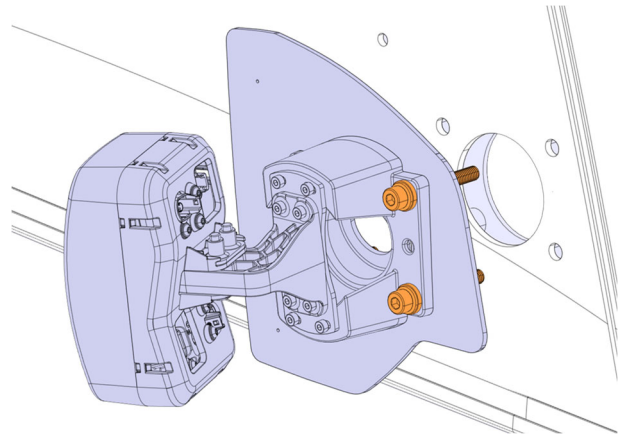

5. Secure the camera with the nuts 5001983 (4x) and washer 500381 (4x).

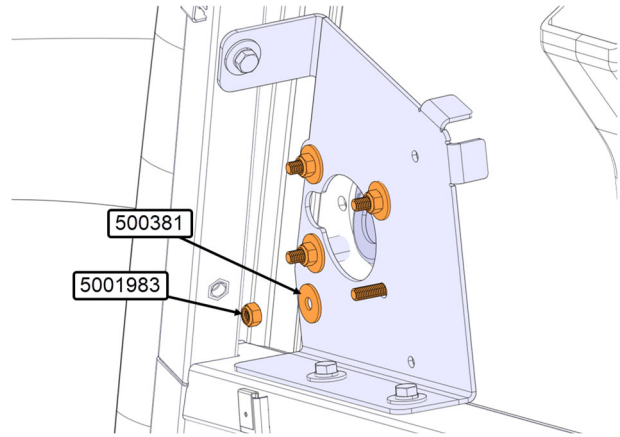

6. Drill one (1) holes \varnothing 3/8".

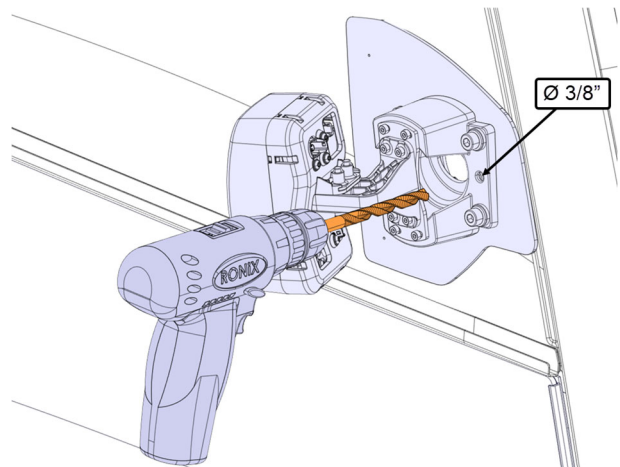

H. CONNECT CAMERA (with option READY)

1. Plug the harnesses 901816 (black connector) and 901817 (white connector) on the left camera.
2. Plug the harness 901901 on the left camera.

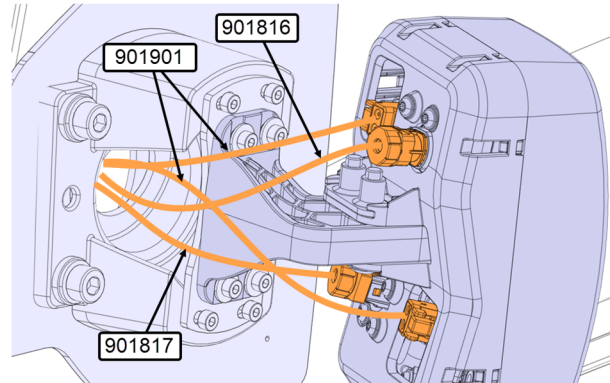

3. Plug the air hoses to the left camera.

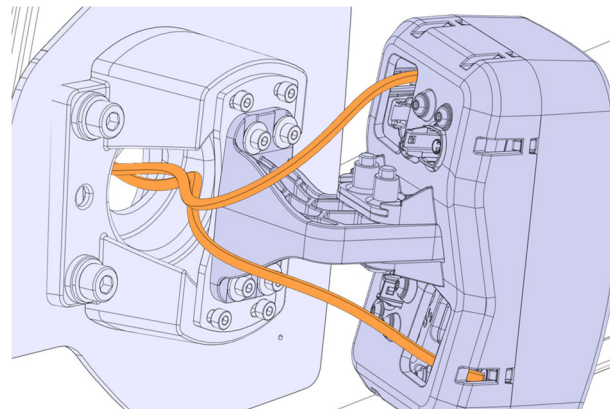

4. Plug the harnesses 901896 (black connector) and 901895 (white connector) on the right camera.
5. Plug the harness 901901 on the right camera.

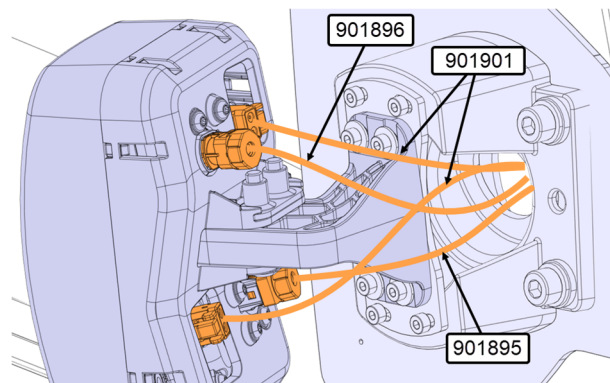

6. Plug the air hoses to the right camera.

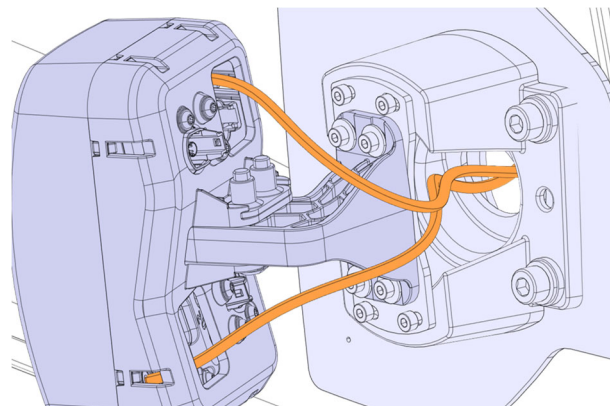

I. INSTALLATION OF HARNESES (without option READY)

With X3-45 VIP

1. Locate connector **C130** on the main dashboard harness.
2. Plug the connector **C130** of harness 0610559 to connector **C130** of the main dashboard harness.

With X3-45 COACH

3. Locate connector **C600** on the main dashboard harness.
4. Plug the connector **C600** of harness 0610480 to connector **C600** of the main dashboard harness.

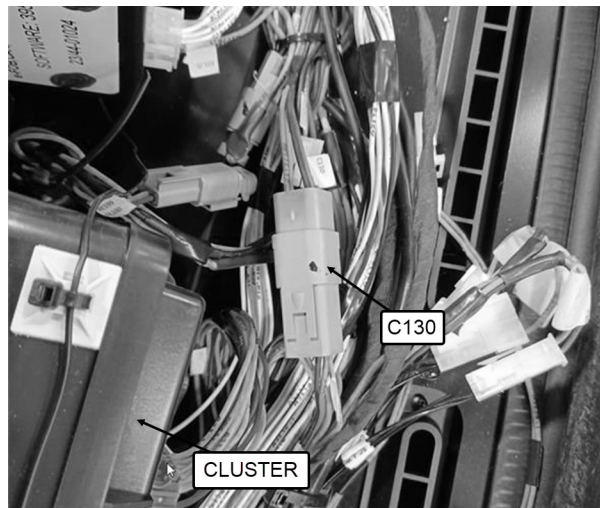

With X3-45 VIP

5. Run the harness 0610559 along the front dash.
6. Run the harness 0610559 section with connectors **A222M.A**, **A222M.B**, **A222M.C** to the front bottom of the left pillar for the left monitor.

With X3-45 COACH

7. Run the harness 0610480 along the front dash.
8. Run the harness 0610480 section with connectors **A222M.A**, **A222M.B**, **A222M.C** to the front bottom of the left pillar for the left monitor.

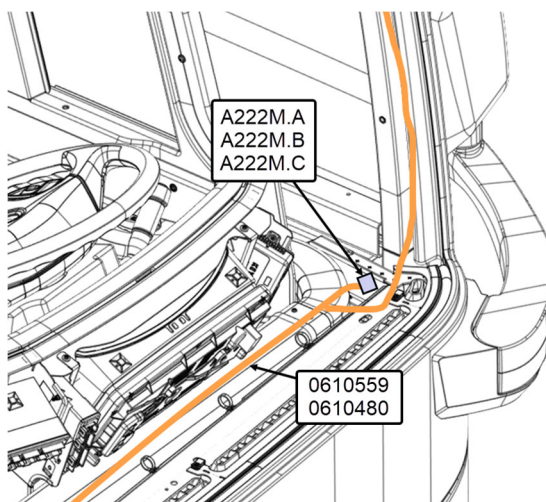

9. Connect the harness 901897 to connector **A222M.A**, **A222M.B**, **A222M.C**.

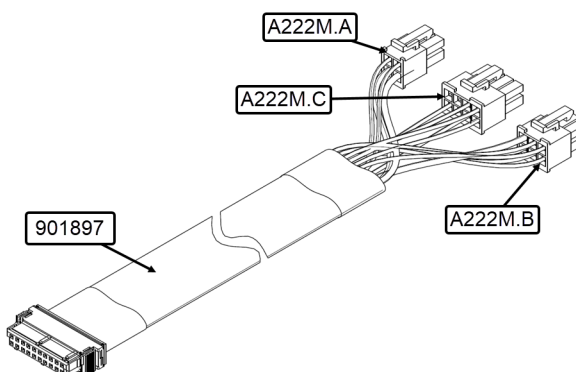

10. Run the harness 901897 on the left pillar to connect the left monitor.

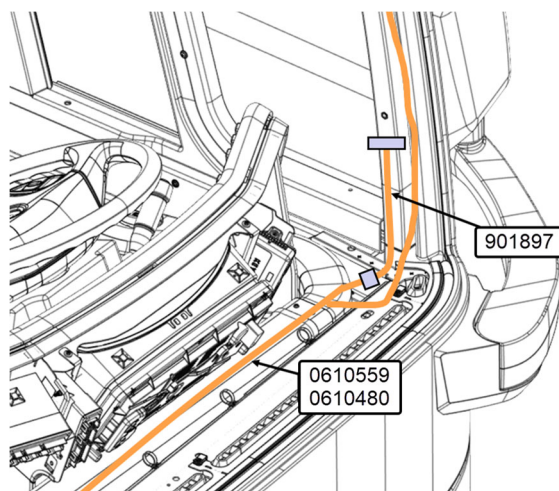

11. Run the harnesses 901816 (black connector) and 901817 (white connector) on the left pillar to connect the left monitor to the left camera.

With X3-45 VIP

12. Run the harness 0610559 section with connectors **A222W.A** on the left pillar for the left cameras defrost

With X3-45 COACH

13. Run the harness 0610480 section with connectors **A222W.A** on the left pillar for the left cameras defrost.

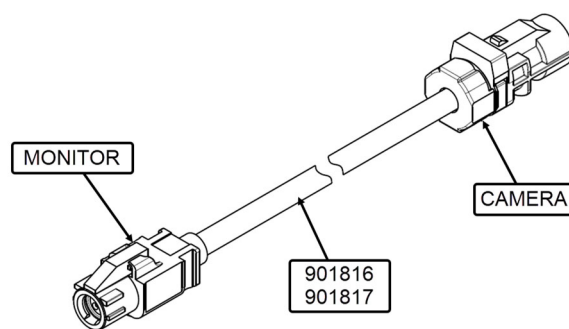
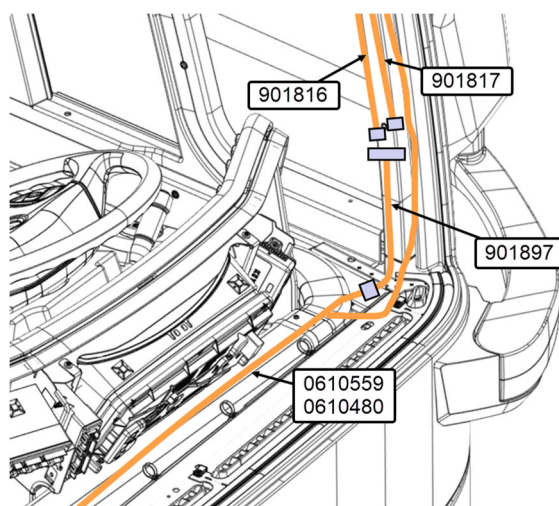

14. Run the harnesses 901816 (black connector) and 901817 (white connector) on the left pillar to the camera.

With X3-45 VIP

15. Run the harness 0610559 section with connectors **A222W.A** on the left pillar for the left cameras defrost.

With X3-45 COACH

16. Run the harness 0610480 section with connectors **A222W.A** on the left pillar for the left cameras defrost.

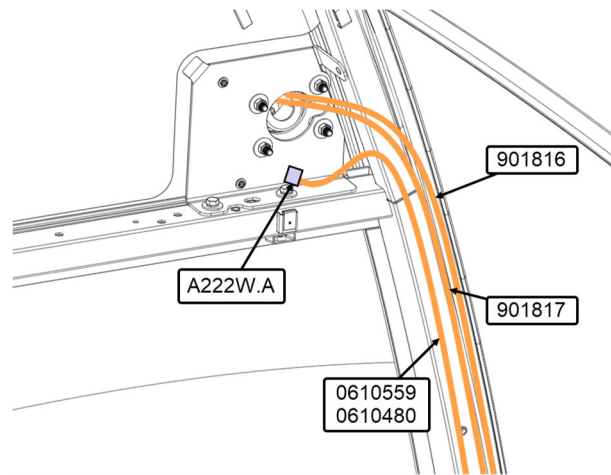

17. Connect the harness 901901 to connector **A222W.A**.

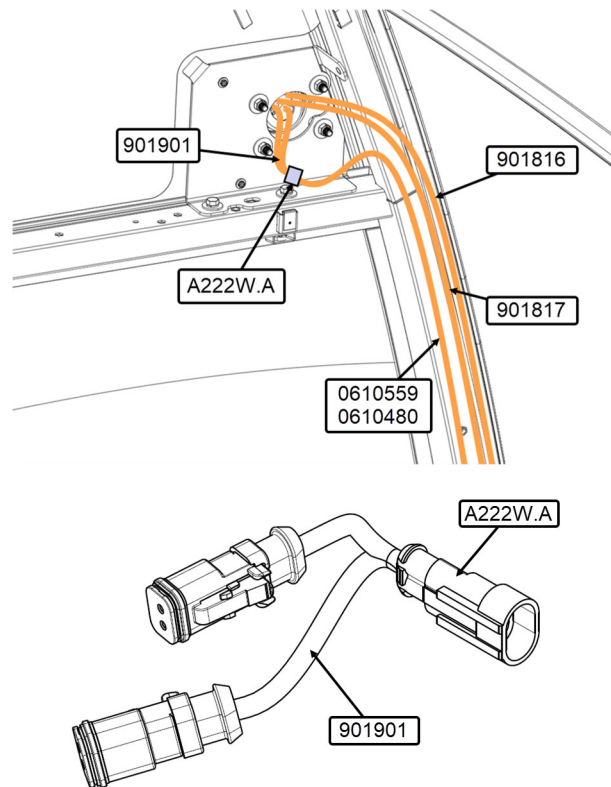

18. Plug the harnesses 901816 (black connector) and 901817 (white connector) on the left camera.

19. Plug the harness 901901 on the left camera.

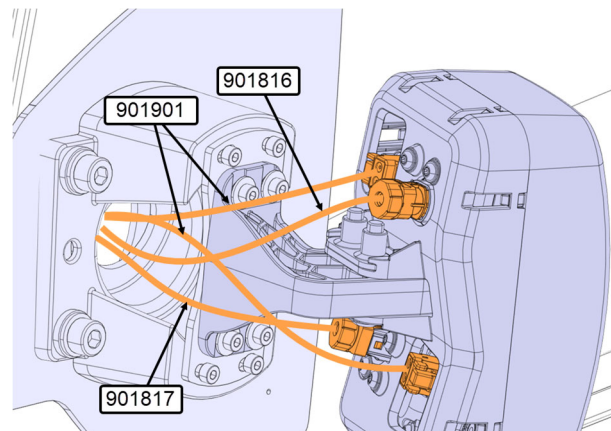

20. Run the harness section with connectors **A223M.A**, **A223M.B**, **A223M.C** to the center pillar for the central monitor.

With X3-45 VIP

21. Run the harness 0610559 section with connectors **A223W.A** inside right dash section to go to the right cameras defrost.

With X3-45 COACH

22. Run the harness 0610480 section with connectors **A223W.A** inside right dash section to go to the right cameras defrost.

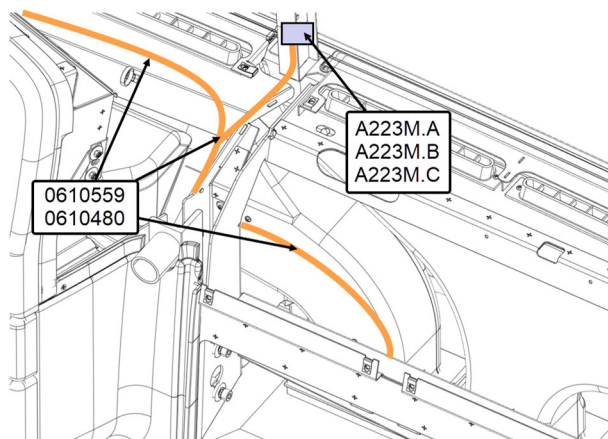

23. Connect the harness 901897 to connector **A223M.A**, **A223M.B**, **A223M.C**.

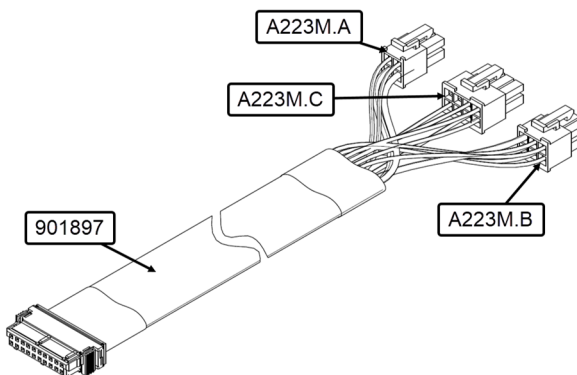

24. Run the harnesses 901896 (black connector) and 901895 (white connector) on central pillar to connect the central monitor to the right camera.

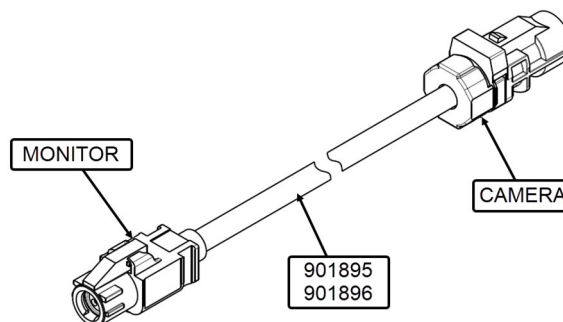
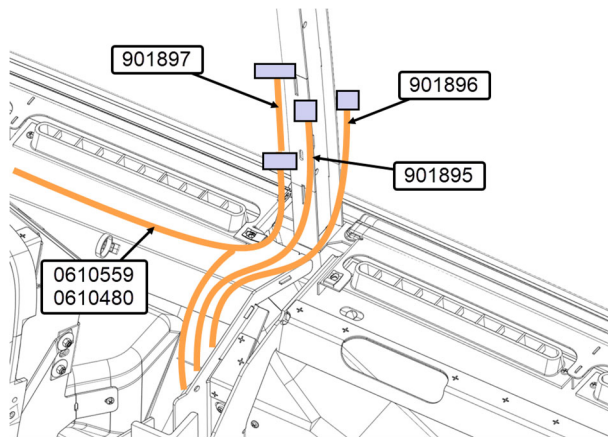

With X3-45 VIP

25. Run the harnesses 0610559 section with connectors **A223W.A** and 901896 (black connector) and 901895 (white connector) on central pillar to connect the central monitor to the right camera following the door harness.

With X3-45 COACH

26. Run the harnesses 0610480 section with connectors **A223W.A** and 901896 (black connector) and 901895 (white connector) on central pillar to connect the central monitor to the right camera following the door harness.

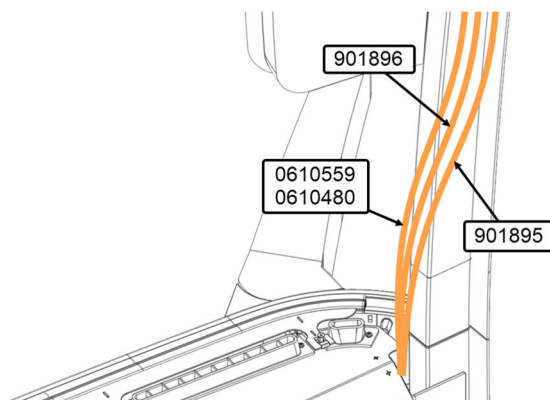
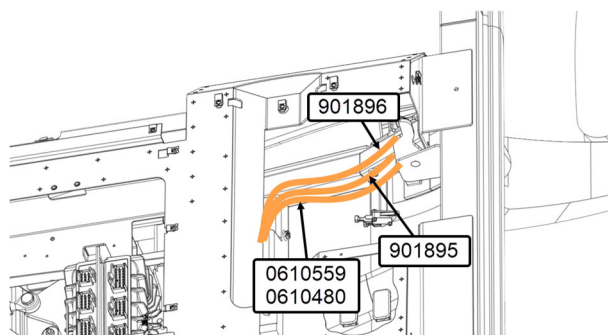
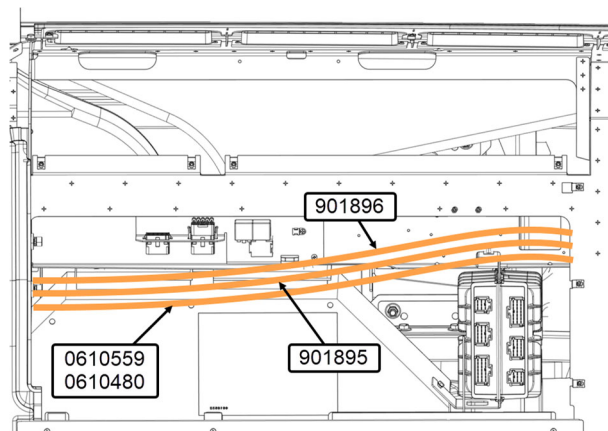

27. Run the harnesses 901896 (black connector) and 901895 (white connector) on the right pillar to the camera.

With X3-45 VIP

28. Run the harness 0610559 section with connectors **A223W.A** on the right pillar for the right cameras defrost.

With X3-45 COACH

29. Run the harness 0610480 section with connectors **A223W.A** on the right pillar for the right cameras defrost.

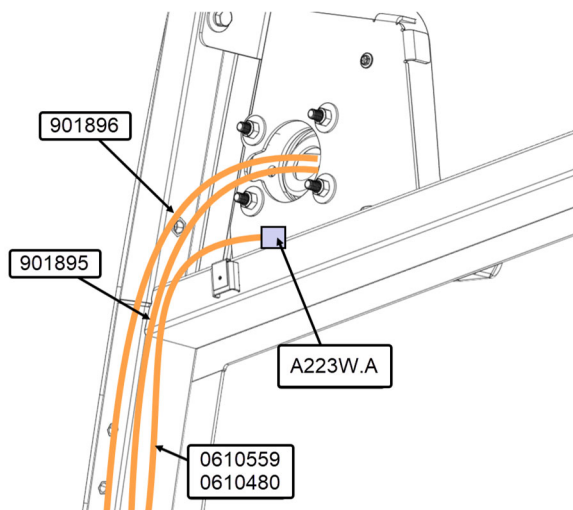

30. Connect harness 901901 to connector **A223W.A**.

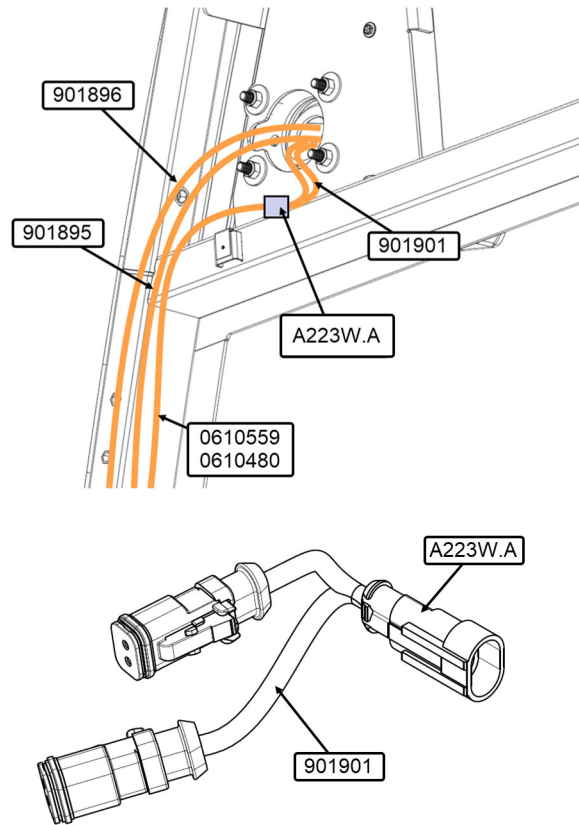

31. Plug the harnesses 901896 (black connector) and 901895 (white connector) on the right camera.

32. Plug the harness 901901 on the right camera.

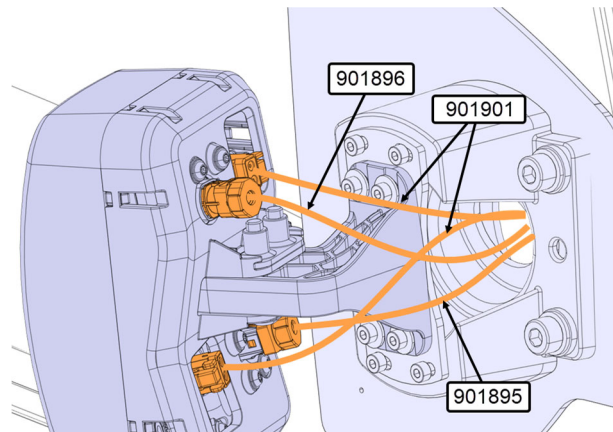

J. INSTALLATION SOLENOID VALVE (without option READY)

Assemble fittings on the solenoid valve.

1. Apply thread sealant 680098 on fittings 641332, 501312 and 642127.
2. Connect the fitting 641332 to the solenoid valve 562804.
3. Connect the fitting 501312 to solenoid valve 562804.
4. Connect the fitting 642127 to the fitting 501312.

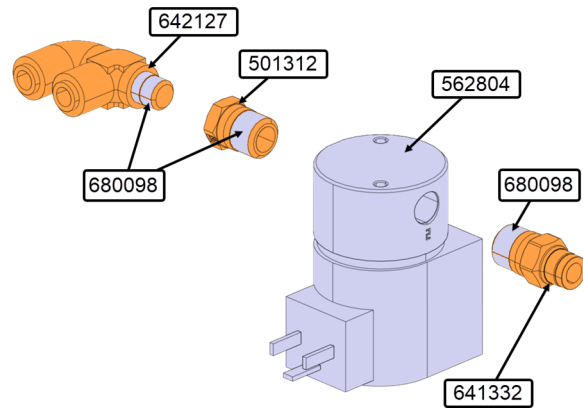

5. Assemble the solenoid valve assembly on the support 140374 with the screws 502751 (2x).
6. Install the fir tree mounting 509815.

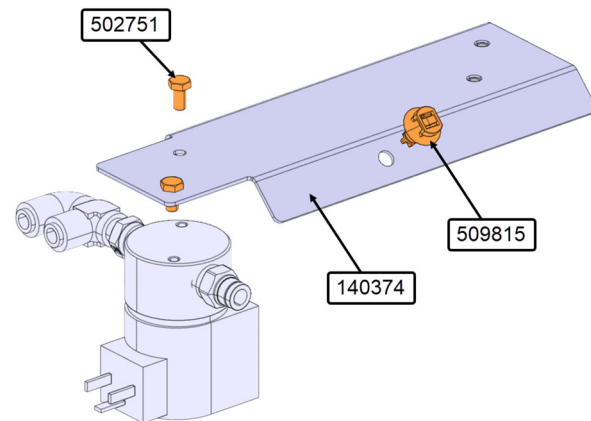

7. Open the front service door.

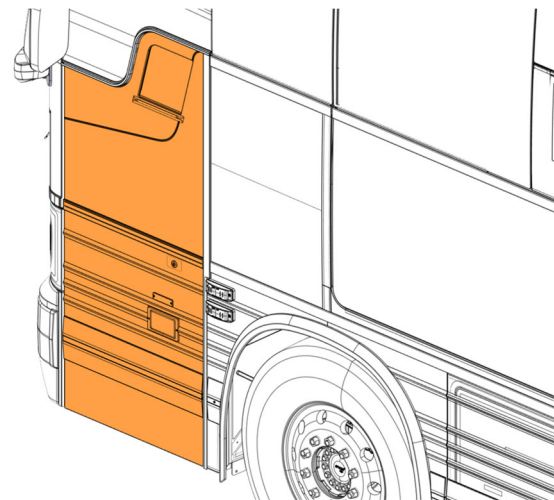

8. Locate the front pneumatic panel.

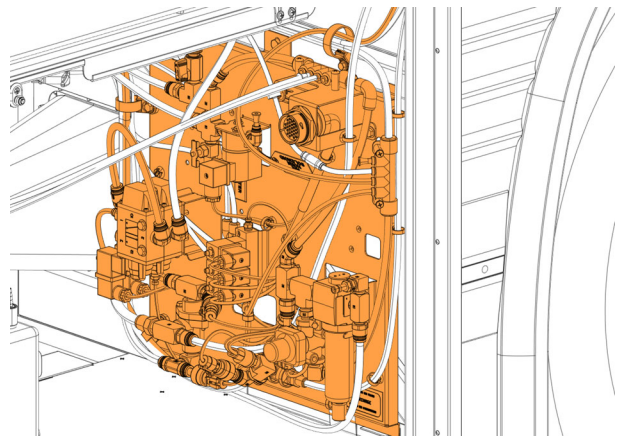

9. Secure the solenoid valve assembly 562804 with the screws 5001670 (2x), the washers 5002031 (2x).

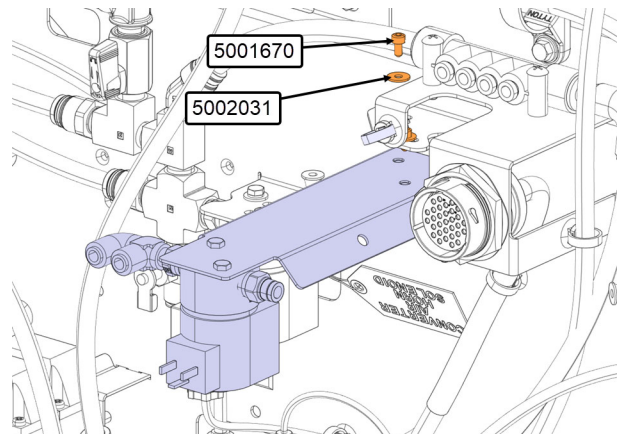

10. Plug the connector **So60** from the pneumatic panel harness to the solenoid valve 562804.

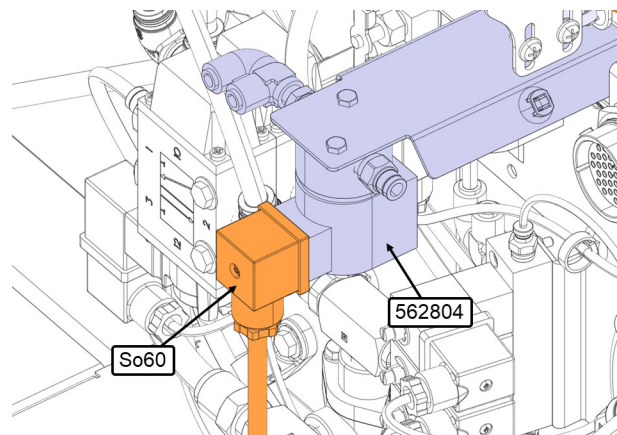

11. Cut a length of 9" (230mm) of hose 503402.
12. Plug hose 503402 (9" / 230mm) to the solenoid valve 562804 and plug to the manifold pneumatic air supply.

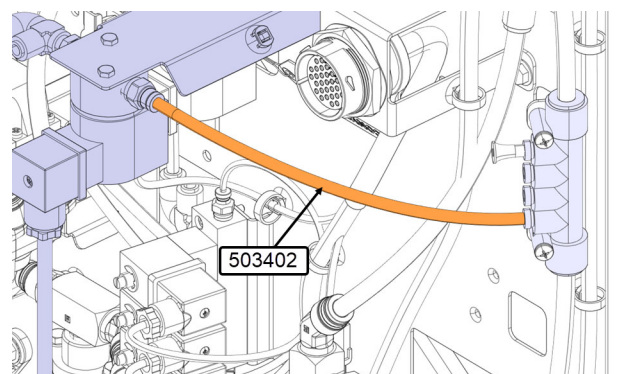

K. INSTALLATION OF THE PNEUMATIC HOSES (without option READY)

Pneumatic assemblies for the camera (2x)

1. Apply thread sealant 680098 on fitting 641028.
2. Connect fitting 640057 with fitting 641028.
3. Connect the hoses 145038 (350mm) (2x) to fitting 640058.

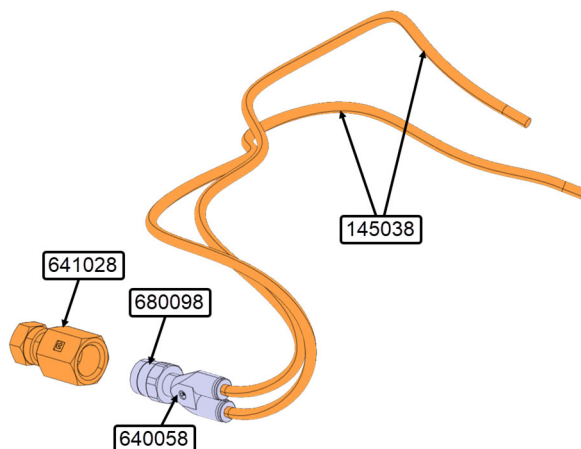

4. Cut a 10-foot length of hose 504302 for the left camera.
5. Cut a 17-foot length of hose 504302 for the right camera.
6. Connect two hoses 503402 to the solenoid valve.
7. Run the hose behind the front junction box to reach the rear section of the dash.

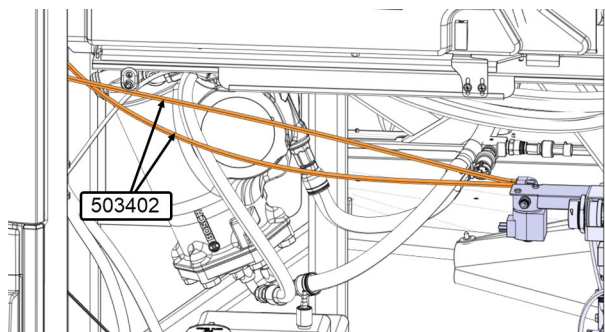
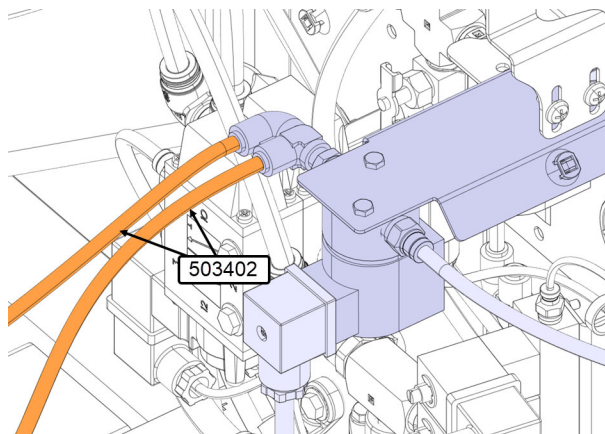

8. Run one hose 503402 (10ft) on the left pillar to reach the left camera.
9. Run the second hose 503402(17ft) inside the dash to reach the right camera.

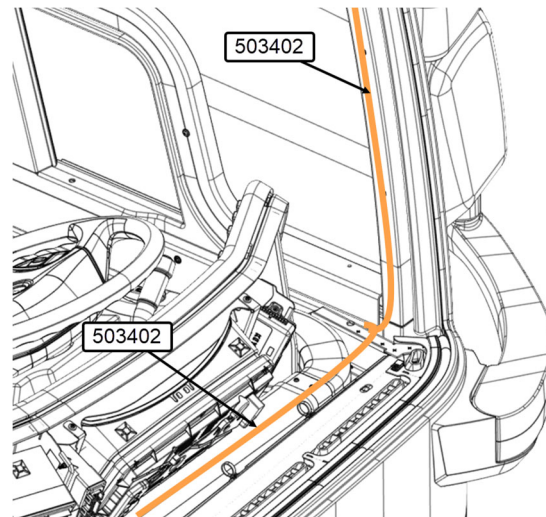

10. Run one hose 503402 (10ft) on the left pillar to reach the left camera.
11. Adjust the hose length.

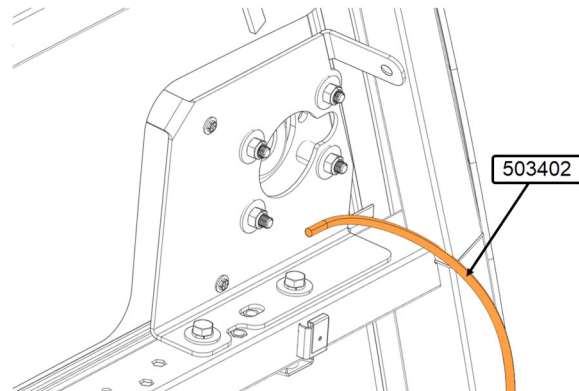

12. Connect the hose 503402 to the pneumatic assembly for the camera.

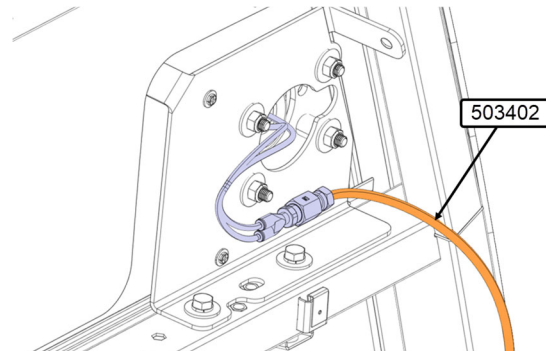

13. Plug the air hoses to the left camera.

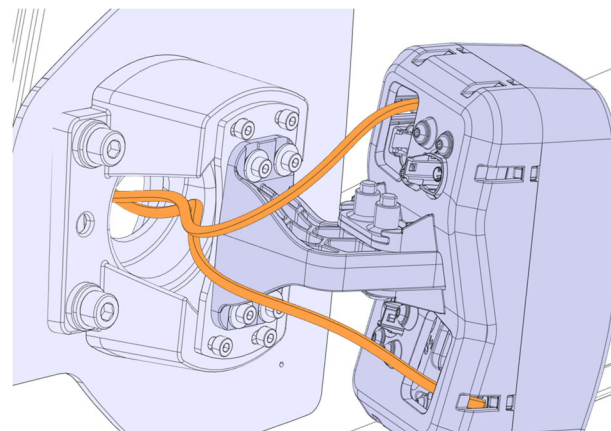

14. Run the second hose 503402(17ft) inside the dash to reach the right camera.

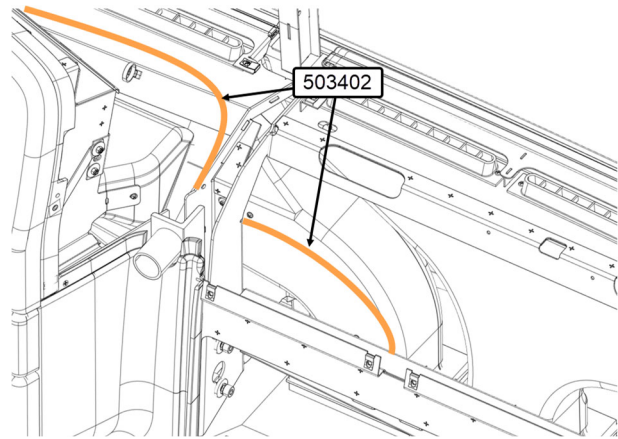

15. Run the second hose 503402(17ft) inside the dash to reach the right camera.

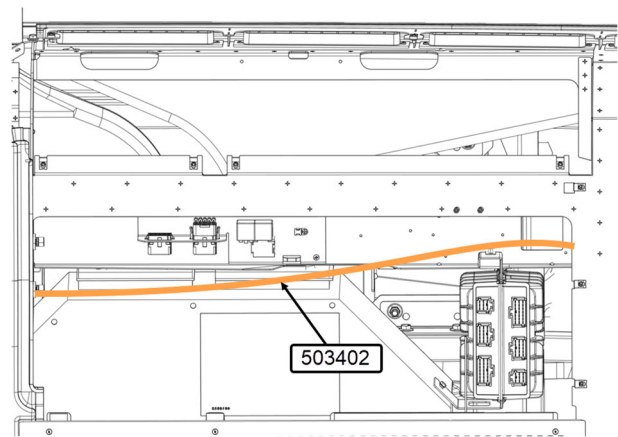

16. Run the second hose 503402 (17ft) inside the dash to reach the right camera.

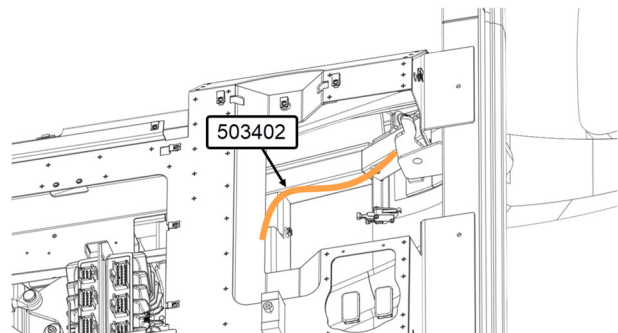

17. Run the second hose 503402(17ft) on the right pillar to the camera.

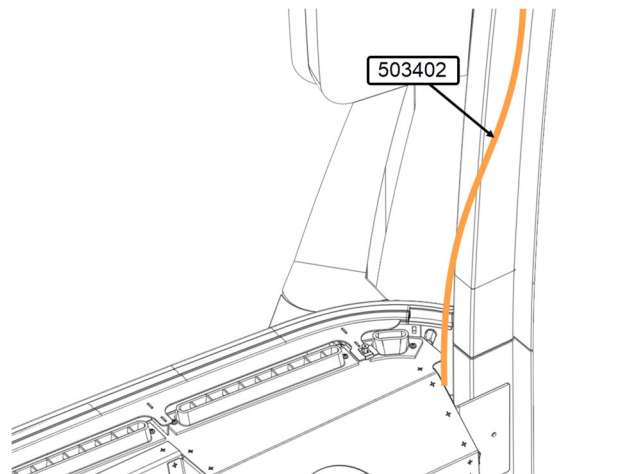

18. Run the second hose 503402(17ft) on the right pillar to the camera.
19. Adjust the hose length.

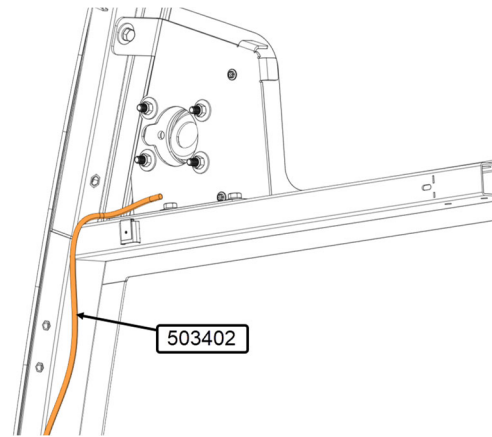

20. Connect the hose 503402 to the pneumatic assemblies for the camera.

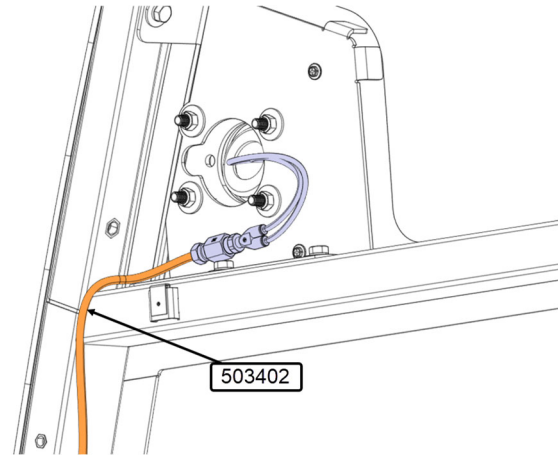

21. Plug the air hoses to the right camera.

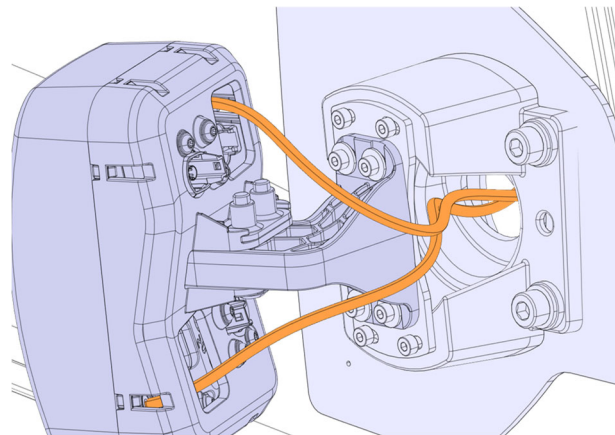

L. INSTALLATION OF THE MONITOR SUPPORTS

1. Install the central fixation 406811 with the screw 502622 (4x) and the lock washers 5001432 (4x).

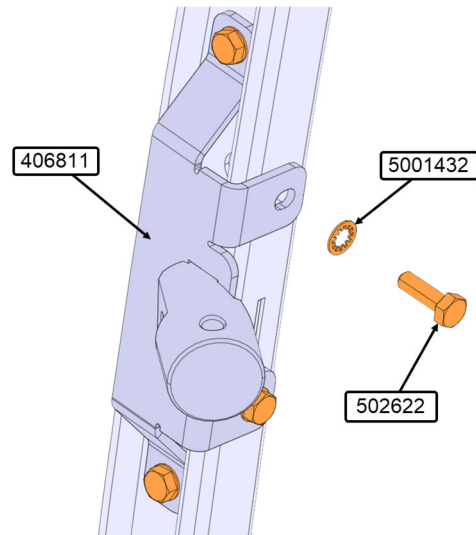

2. Install the left fixation 406813 with the screw 5001433 (2x), the lock washers 502853 (2x) and the flat washer 5001976 (2x).

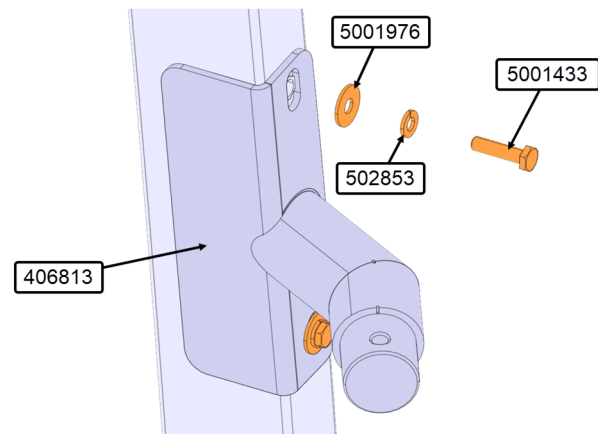

M. SECURE THE HARNESSES AND THE PNEUMATIC HOSES

1. Install the square mounts 562679 (8x) on the structure.

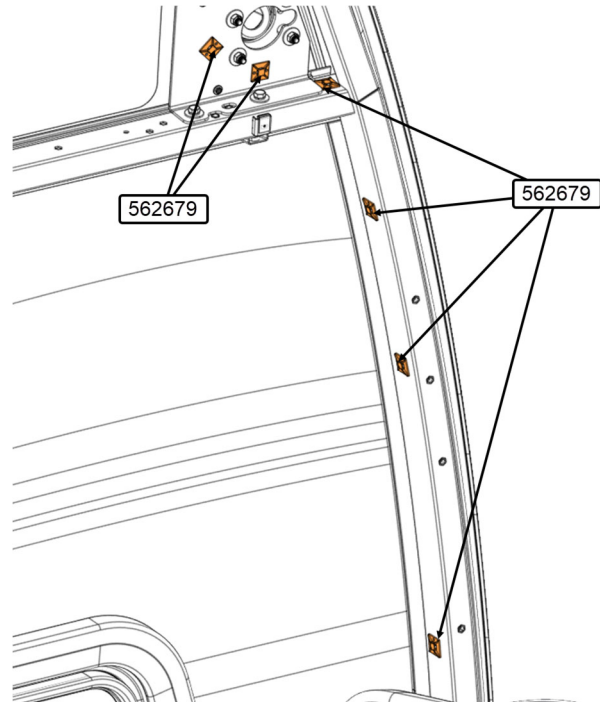

2. Install the square mounts 562679 (8x) on the structure.

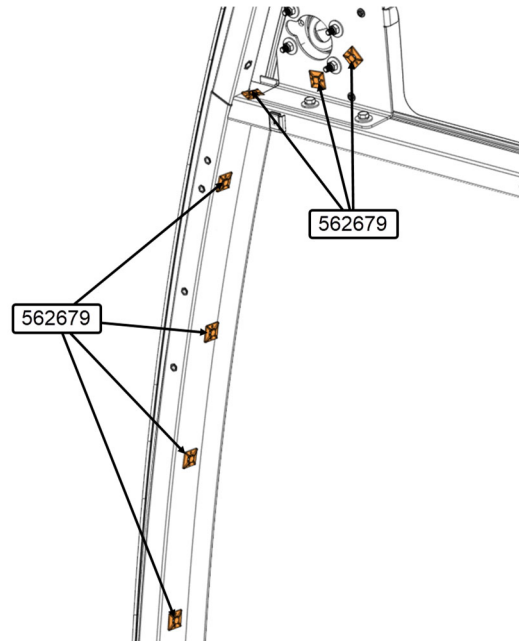

3. Secure all the harnesses and the pneumatic hoses to the square mounts or to an existing harness with the cable ties 504637 (34x).

N. REINSTALL WINDSHIELDS (without option READY)

If you have changed the central post

Reinstall the windshields (see maintenance manual)

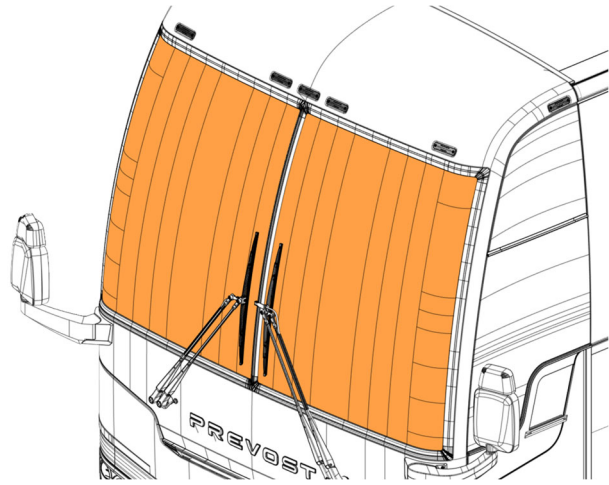

O. REINSTALL DASH COVERS (without option READY)

1. Reinstall the top right dash panel with the screws (3x) and the washers (3x).

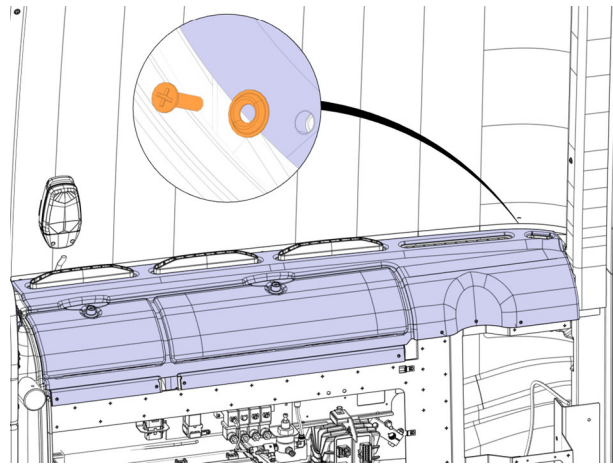

2. Reinstall the entrance door cover mechanism with the screws (5x) and the washers (5x).

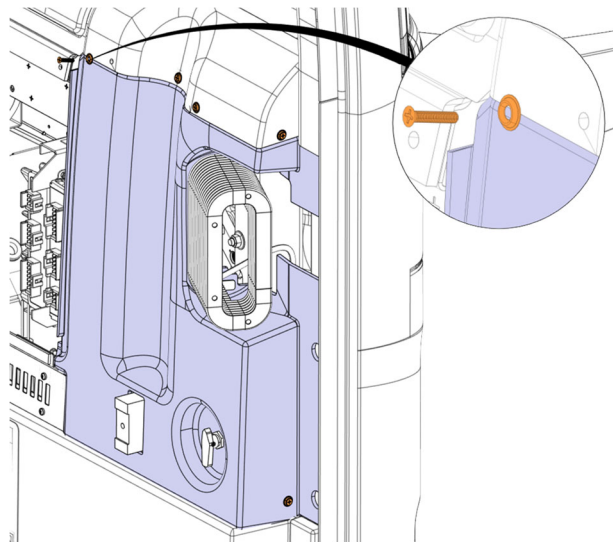

3. Reinstall the defroster access panel with the screws (4x) and the washers (4x).

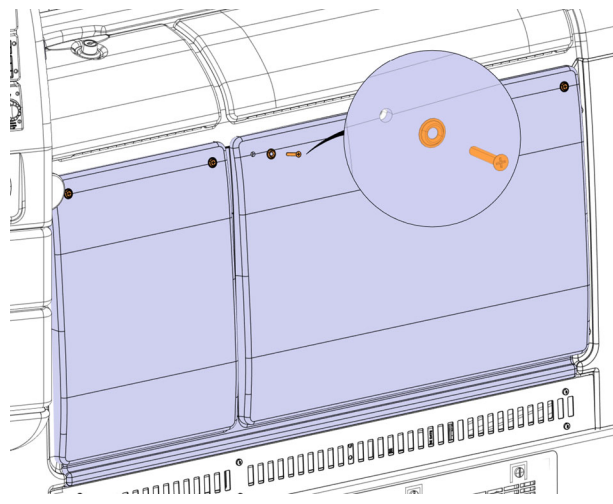

4. Reinstall the dash cover panel with the screws (5x) and the washers (5x).

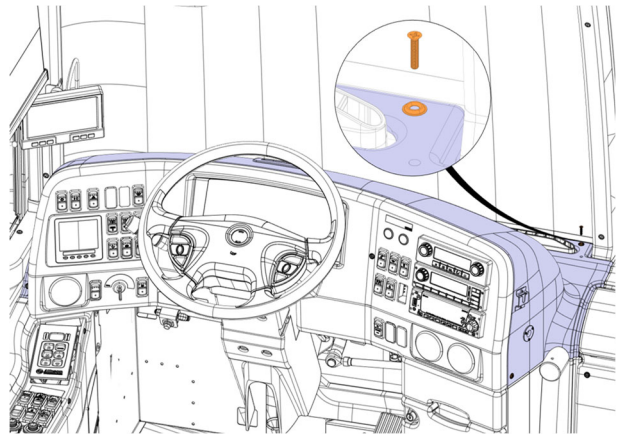

P. REINSTALL FRONT CAP INTERIOR FINISHING

1. Create a cutout in the left pillar cover for the monitor support.

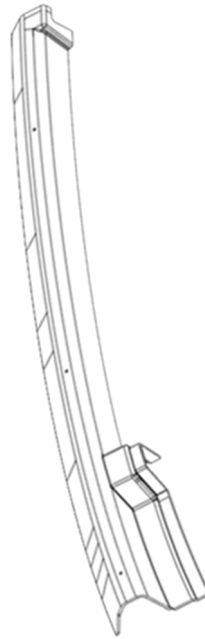

2. Reinstall the left pillar cover with the screws (3x).

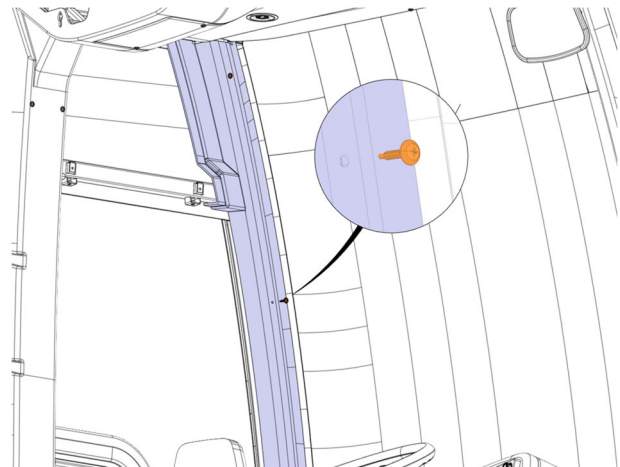

3. Reinstall mirror support (X3-45 coach only).

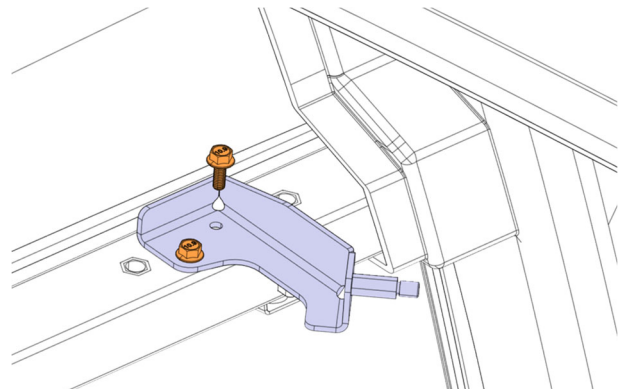

4. Reinstall the driver's window upper panel with the screws (2x).

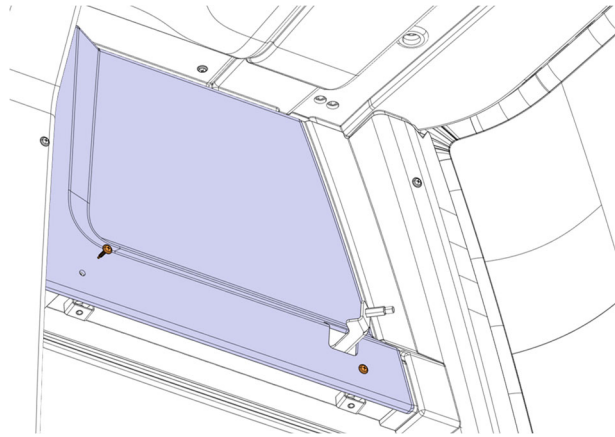

5. Create a cutout in the central pillar cover for the monitor support.

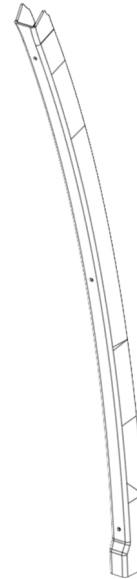

6. Reinstall the central pillar cover with the screws (3x).

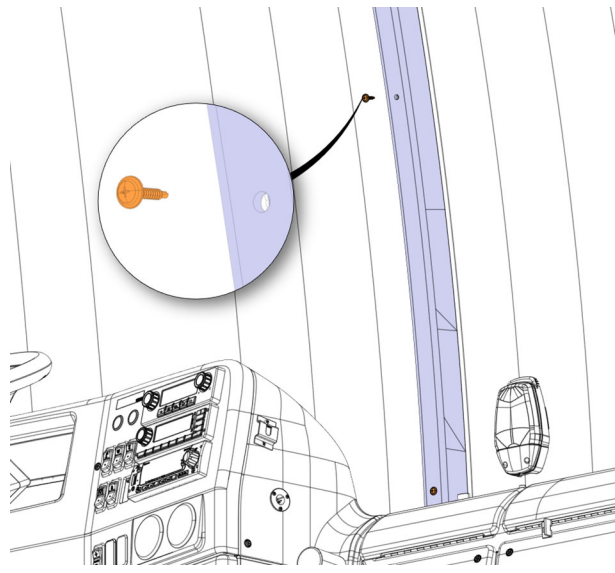

7. Reinstall the right pillar cover with the screws (3x).

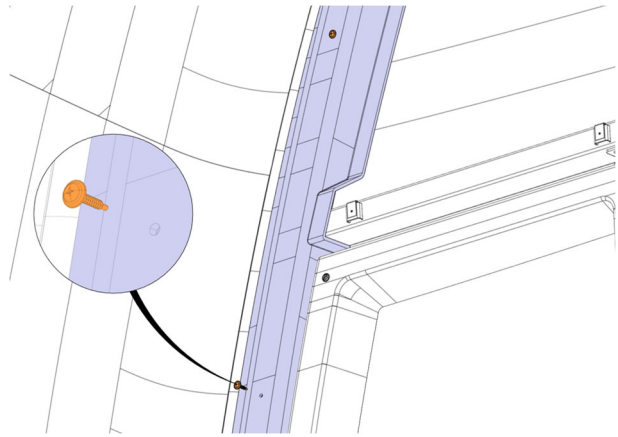

8. Reinstall the entrance door upper panel with the screws (2x).

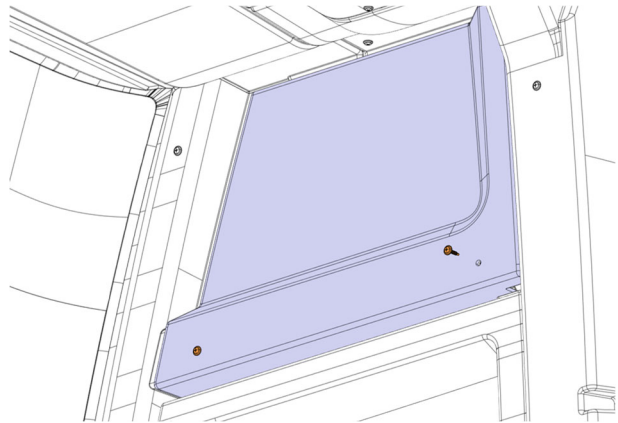

Q. REINSTALL MIRROR AND SUNSHADES

1. Reinstall the driver's sunshade. (X3-45 coach only)

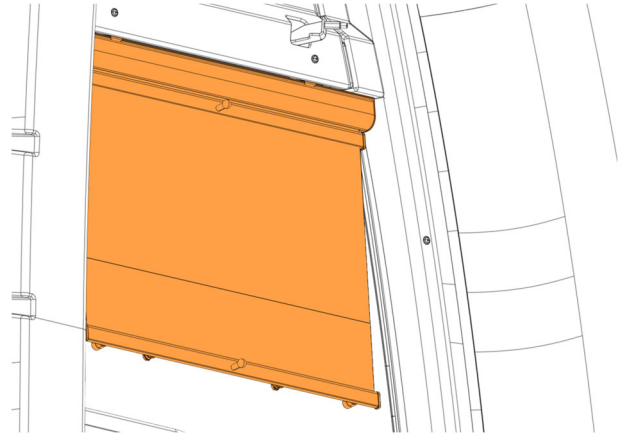

2. Reinstall front sunshades.

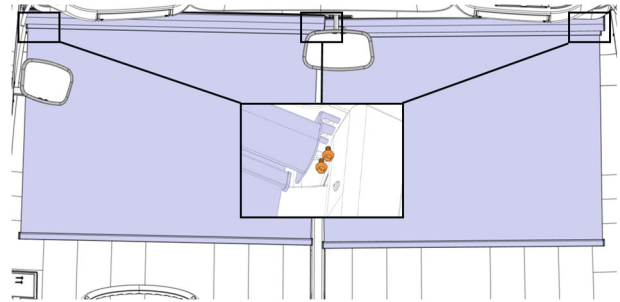

3. Reinstall interior mirrors (X3-45 coach only)

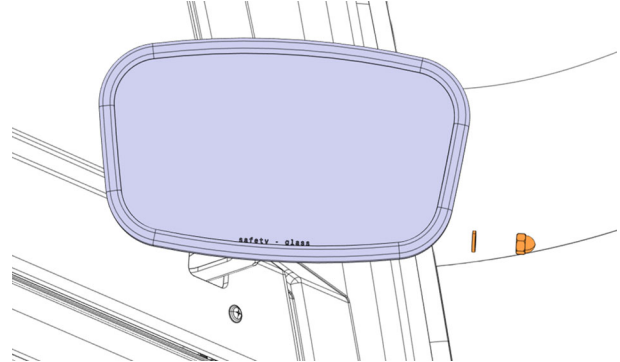

R. INSTALLATION OF THE MONITORS

With X3-45 VIP

1. Install the supports 403848 (2x) on monitors 901912(2x) with the screws 5000353 (8x).
2. Torque to **53 lb-in.**

With X3-45 COACH

3. Install the supports 403848 (2x) on monitors 901982 (2x) with the screws 5000353 (8x).
4. Torque to **53 lb-in.**

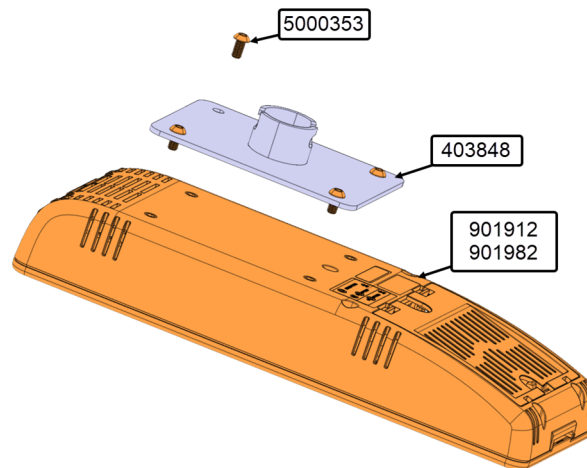

5. Install the screws 502927 (2x) and the nuts 5001983 (2x) on the central fixation 406811 and on the left fixation 406813.

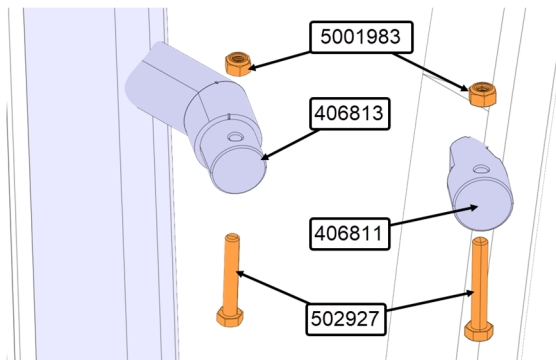

With X3-45 VIP

6. Remove the access panel of the monitors 901912 (2x).

With X3-45 COACH

7. Remove the access panel of the monitors 901982 (2x).

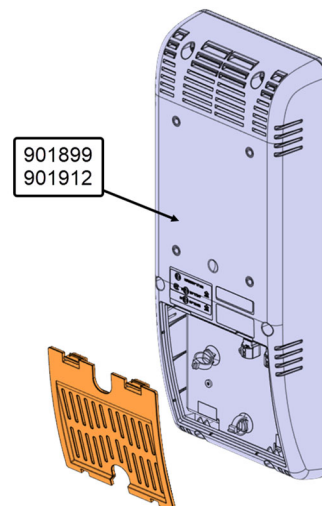

With X3-45 VIP

8. Plug the harnesses 901897, 901816 (the black connector) and 901817 (the white connector) to the left monitor 901812.
9. Secure the harness with the cable ties 504637 (2x).

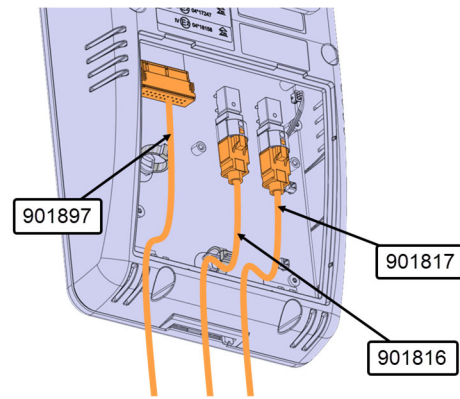

With X3-45 COACH

10. Plug the harnesses 901897, 901816 (the black connector) and 901817 (the white connector) to the left monitor 901982.
11. Secure the harness with the cable ties 504637 (2x).

12. Reinstall the access panel of the monitor.

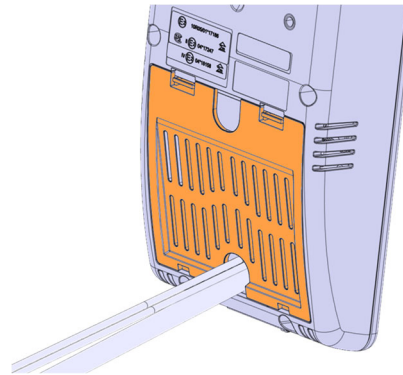

13. Install the monitor on the left fixation 406813.

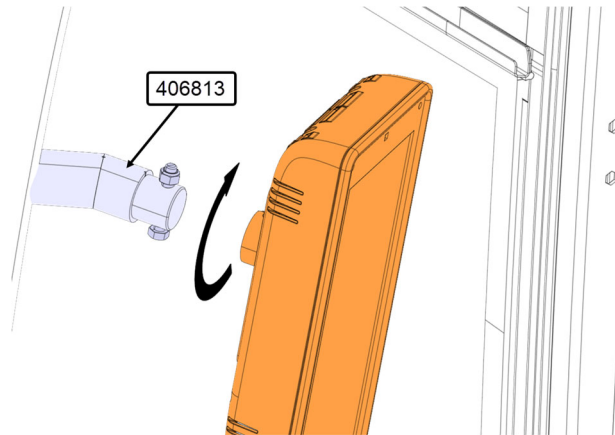

14. On the left fixation torque the screw and nut to **14 lb-ft**.

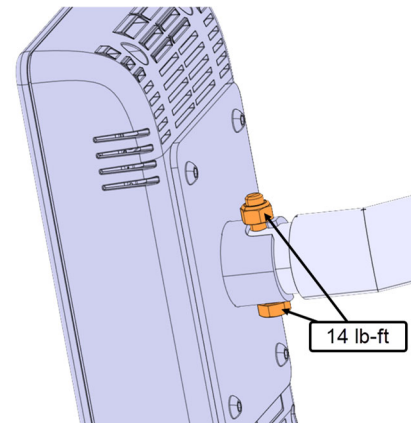

With X3-45 VIP

15. Plug the harnesses 901897, 901816 (the black connector) and 901817 (the white connector) to the central monitor 901912.
16. Secure the harness with the cable ties 504637 (2x).

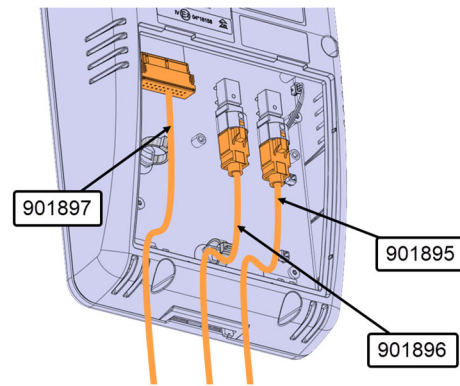

With X3-45 COACH

17. Plug the harnesses 901897, 901816 (the black connector) and 901817 (the white connector) to the central monitor 901982.
18. Secure the harness with the cable ties 504637 (2x).

19. Reinstall the access panel of the monitor.

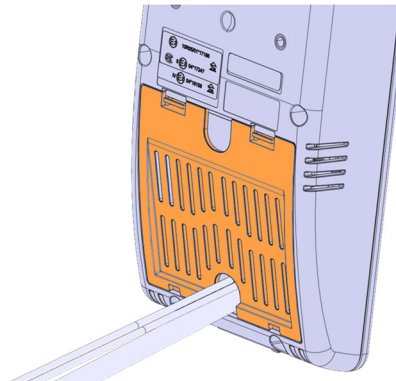

20. Install the monitor on the central fixation 406811.

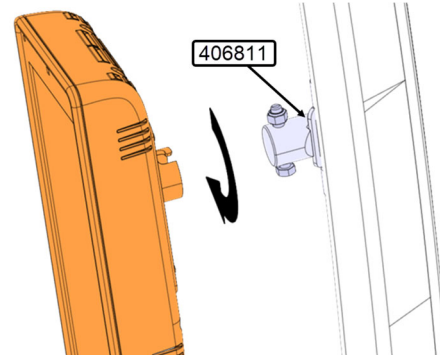

21. On the central fixation torque the screw and nut to **14 lb-ft**.

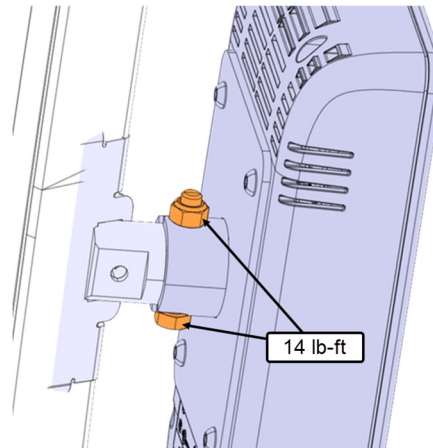

S. CAMERAS ALIGNMENT

1. Install a reference point 30 centimeter (1 foot) behind the center of the axle on both sides of the vehicle.
2. Install a reference point 1 meter (3 feet and 3 inches) behind the end of the vehicle on both sides of the vehicle.

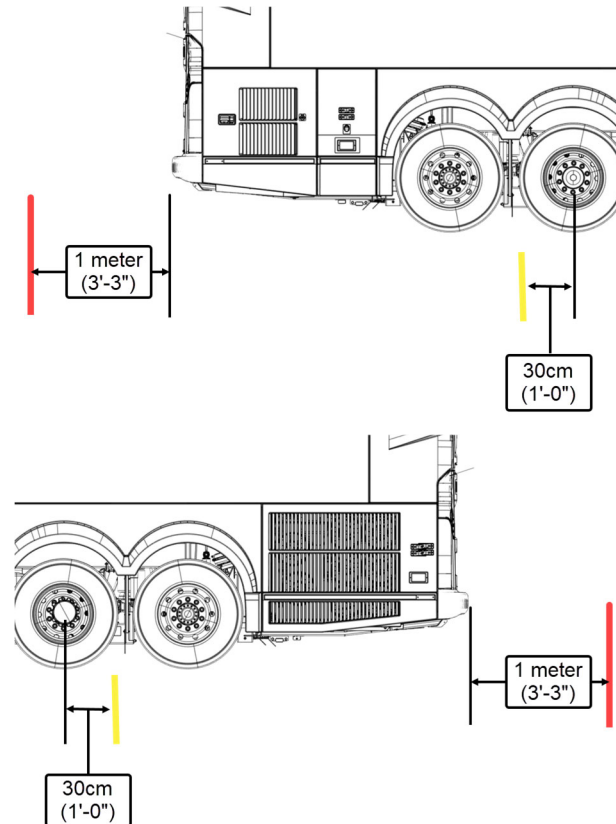

3. Y adjustment (width)

The beginning of the yellow line touches on the side of the vehicle.

Tolerances

The yellow line may interfere with the side of the vehicle by 2mm and may not touch it by 4mm.

- If the measurement is not acceptable, go to the next step.
- If the measurement is OK, go to step 13.

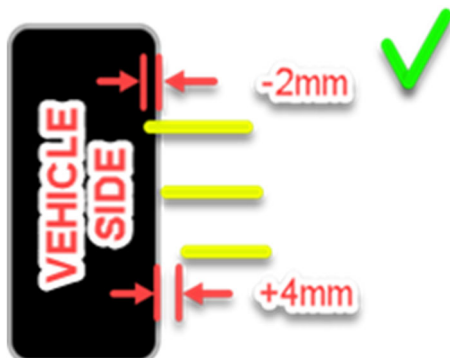
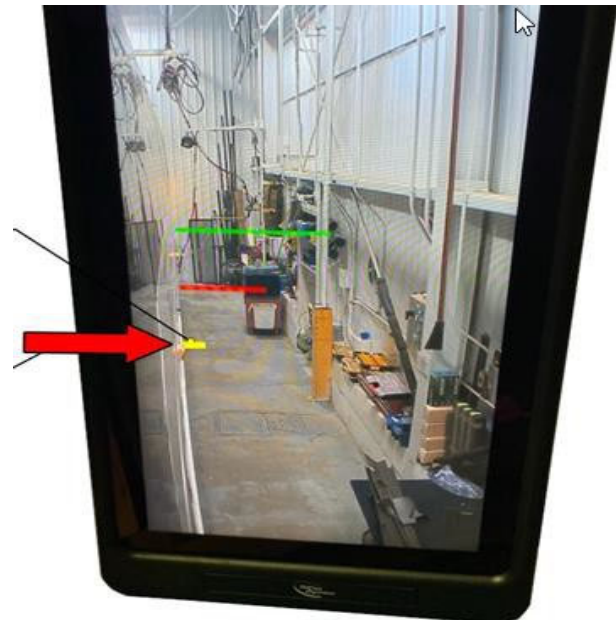

If the measurement is not acceptable but is within 1 to 1.5 mm of tolerance, you can try this:

4. Slightly unscrew the bolts holding the camera.
5. Rotate the camera to the side required for adjustment to take up the (minimal) play between the bolts and the plastic parts.
6. Tighten bolts, maintaining pressure on the required side.
7. Torque bolts to 88 lb-in
8. Revalidate the measurement at point 3.
 - If the measurement is not acceptable, go to the next step.
 - If the measurement is OK, go to step 13.

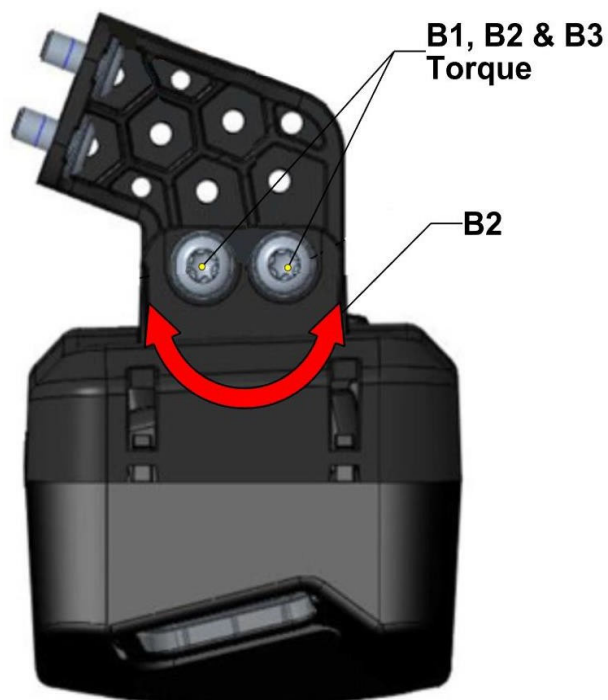

If the measurement is not acceptable but is more than 1.5 mm out of tolerance:

9. Unscrew the bolts holding the plate in place.
10. Rotate the assembled camera to the side required for adjustment (picture shows front)
11. Insert the spacer 492178 by sliding in the bottom first, then rotating the top to complete insertion.
12. Revalidate the measurement at point 3.
 - If the measurement is not acceptable, adding a spacer and revalidate.
 - If the measurement is OK, go to step 13.

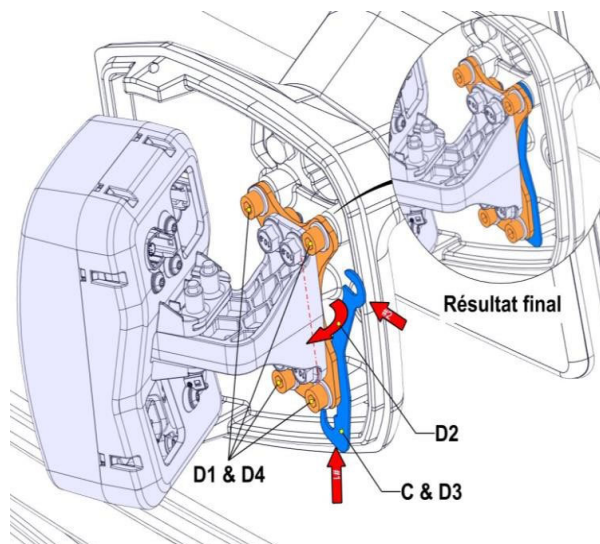

13. X adjustment (length)

Confirm that the yellow line in the display is aligned with the reference point.

LEFT SIDE



RIGHT SIDE



If the lines are not aligned.

14. Unscrew the four bolts.
15. Adjust the camera adjustment plate to the side required to align the lines on the screen.
16. Once the lines are aligned, tighten the bolts so that the adjustment plate cannot move.
17. Reconfirm that the lines are facing each other.

Note: If they are not facing each other, repeat the adjustment.

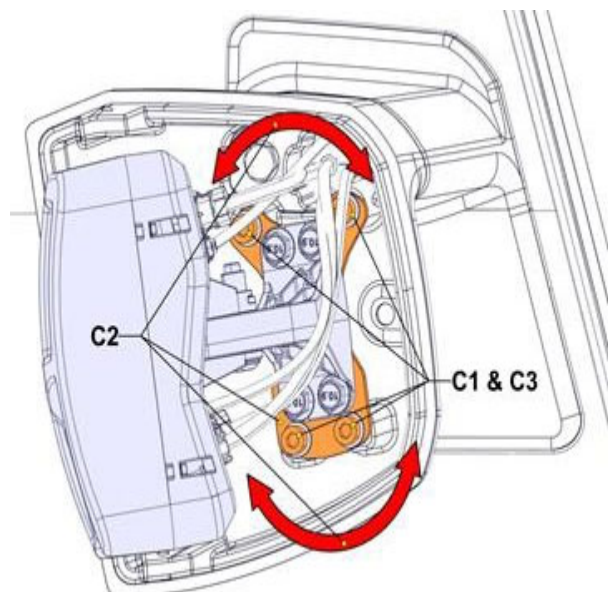

18. Install spring nut 500684 (2x) on the left cover 420121.

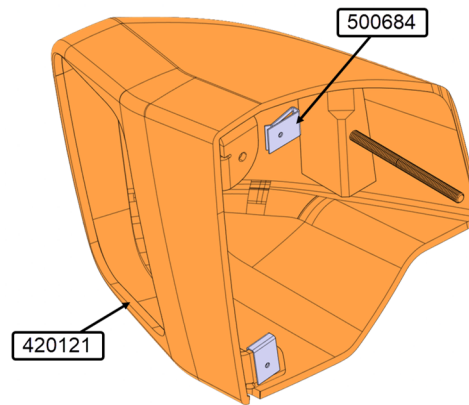

19. Install the left cover 420121 on the vehicle.

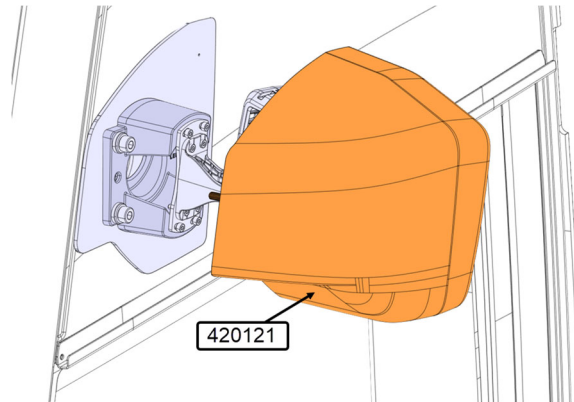

20. Secure the left cover 420121 with the nut 5001182, the washer 502573, the rubber washer 5002214 and with the screws 509916 (2x) and the washers 500804 (2x).

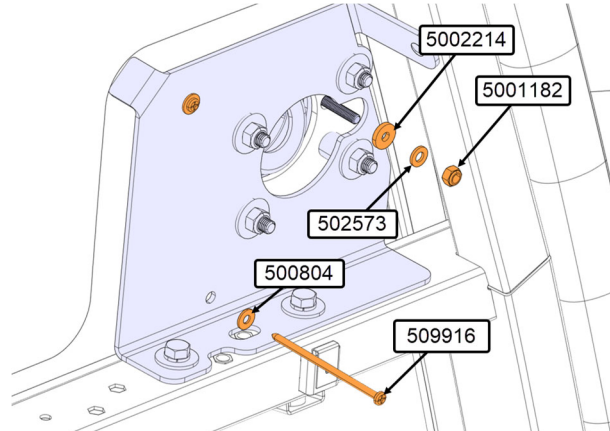

21. Install spring nut 500684 (2x) on the right cover 420122.

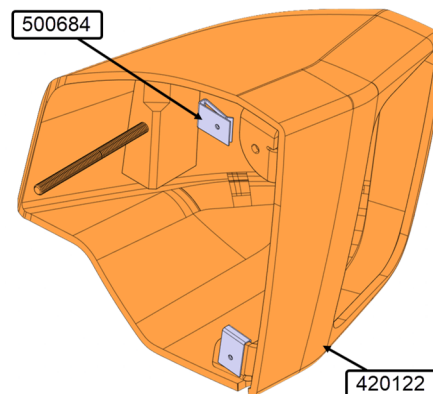

22. Install the right cover 420122 on the vehicle.

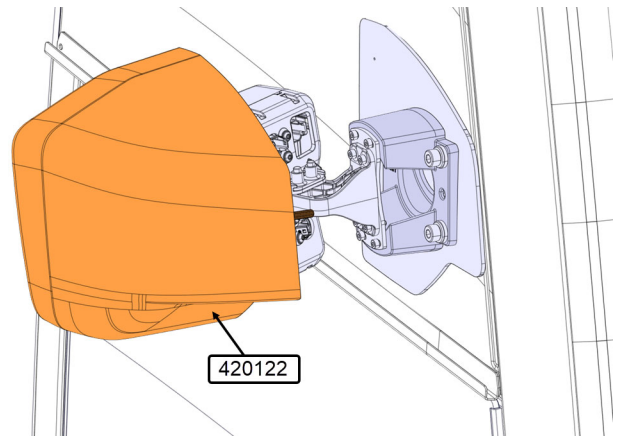

23. Secure the right cover 420122 with the nut 5001182, the washer 502573, the rubber washer 5002214 and with the screws 509916 (2x) and the washers 500804 (2x).

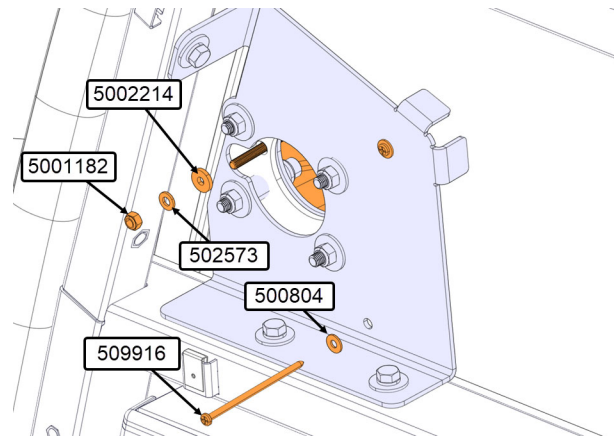

T. PARAMETER PROGRAMMING WITH VPG SOFTWARE TOOL

- In VPG, set parameters.
- EMIRROR set to **Yes**

The screenshot shows the VPG software interface with the 'Vehicle Parameters' tab selected. The interface includes navigation buttons for 'Previous Value' and 'Current Value', and 'Back' and 'Next' buttons. The 'Vehicle Parameters' table is displayed with the following data:

| Para | Description | SI | Default Value | Previous Value | Current Value | New Value |
|---------|-------------------------------------|----|---------------|----------------|---------------|-----------|
| ALTLIN | | | No | | Yes | Yes |
| ALTTYP | Alternator type | | Bosch | | DelcoRemy | DelcoRemy |
| BKRLSW | Park Brake Release Switch | | No | | No | No |
| BRKTYP | Engine Brk or Retarder | | Jacob | | Jacob | Jacob |
| CAMOPT | | | 0 | | 2 | 2 |
| CCCANC | CC Cancel with Wiper | | No | | No | No |
| CDNSPL | | | No | | Yes | Yes |
| CORDO | RH Cornering ON when door open (| | No | | No | No |
| CORNLP | Cornering Lamp | | No | | No | No |
| CRKDIS | Crank Disable | | No | | No | No |
| CURBFL | Curbs Lights ON With RH Flasher | | No | | No | No |
| DECELL | Deceleration Feature on Engine Bra | | Yes | | Yes | Yes |
| DOCFLS | Rear docking with flasher | | No | | No | No |
| DOHAZA | Hazard ON With Entrance Door Ope | | No | | No | No |
| EDPOSI | Entrance door open pulse count (30- | | 34 | | 34 | 34 |
| EMIRROR | | | No | | No | Yes |
| FIREXT | Automatic Fire Extinguisher Option | | Yes | | No | No |
| FOGVIP | Fog Lamp Option | | 0 fog | | 4 fog | 4 fog |

The 'EMIRROR' row is highlighted with a red box around the 'New Value' 'Yes'.

At the bottom of the interface, the status bar shows: User: Jean-Philippe Viens (customer support manage) Profile: Service Network: On-Line MID : Disconnected Last Update: 2024/02/21 12:31:42

PARTS / WASTE DISPOSAL

Discard waste according to applicable environmental regulations (Municipal/State[Prov.]/ Federal)