

PREVOST

Instruction Sheet

IS-99016C

INSTALLATION OF 60A AND 100A VANNER BATTERY EQUALIZER

Revision C :

New model, see OC2001068 – Supplement added – Replace rev. B
--

MATERIAL

Kit #065122 (100 amperes) includes the following parts :

Part No.	Description	Qty
563130	Battery Equalizer, Vanner 65-100 (100 A)	1
IS-99016C	Instruction Sheet	1
FI-99016C	Feuille d'instructions	1

Kit #065121 (60 amperes) includes the following parts :

Part No.	Description	Qty
563129	Battery Equalizer, Vanner 65-60 (60 A)	1
062872	Cable assembly 12C	1
062873	Cable assembly 24C	1
062874	Cable assembly 0C	1
IS-99016C	Instruction Sheet	1
FI-99016C	Feuille d'instructions	1

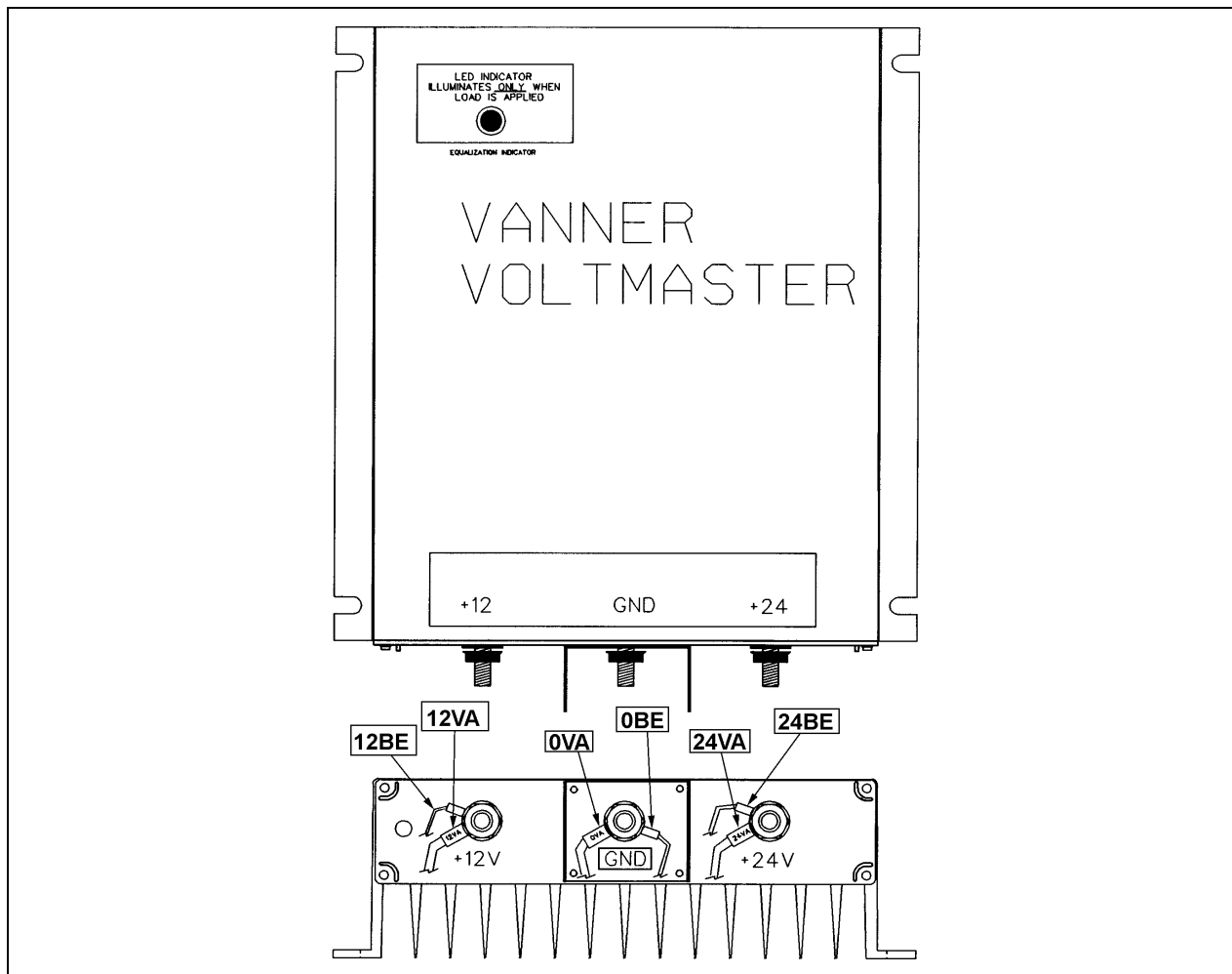

FIGURE 1 : CONNECTIONS FOR ONE 100A EQUALIZER CONFIGURATION

PROCEDURE

Warning : Park vehicle safely, apply parking brake, stop engine and set battery master switch(es) to the OFF position prior to working on the vehicle.

1. Locate the battery equalizer on your vehicle.

H3-41, H3-45, VIP, XL-45 Coach, XLII-45 Coach	Main power compartment
XL-40 Coach, XLII-40 Coach	L.H. side rear baggage compartment
MTH XL & XLII	Engine compartment R.H. side door

2. Remove cable fixing nuts from battery equalizer terminals.

Caution : Battery equalizer is directly connected to batteries and is under voltage. To avoid short circuit damage, always remove equalizer ground cable first and replace equalizer ground cable last.) Using insulating tape, insulate the terminal ends to prevent electrical contact with the surrounding grounded surfaces.

Note : For two 60A equalizers configuration, see figure 2.

3. Remove ground cable (GND or 0VA) first. Then remove 12-volt cable (12VA) and finally, 24 volts cable (24VA). Insulate the exposed ends to prevent electrical contact with the surrounding grounded surfaces.
4. Remove and retain the four nuts fastening the battery equalizer to the vehicle and remove the equalizer. Install the new equalizer and fasten using the nuts retained from the old equalizer. For two equalizers configuration, proceed the same way.
5. For two equalizers configuration, install cables 12C, 0C and 24C.
6. Install cables 24VA and 24BE to +24 equalizer terminal.
7. Install cables 12VA and 12BE to +12 equalizer terminal.
8. Finally, install cables 0VA and 0BE to GND equalizer terminal.
9. Tighten the terminal nuts to a torque of 10 lbs-ft (13.5 Nm) then coat the terminals with "Nyogel" corrosion protective material (Prévost part #683409).

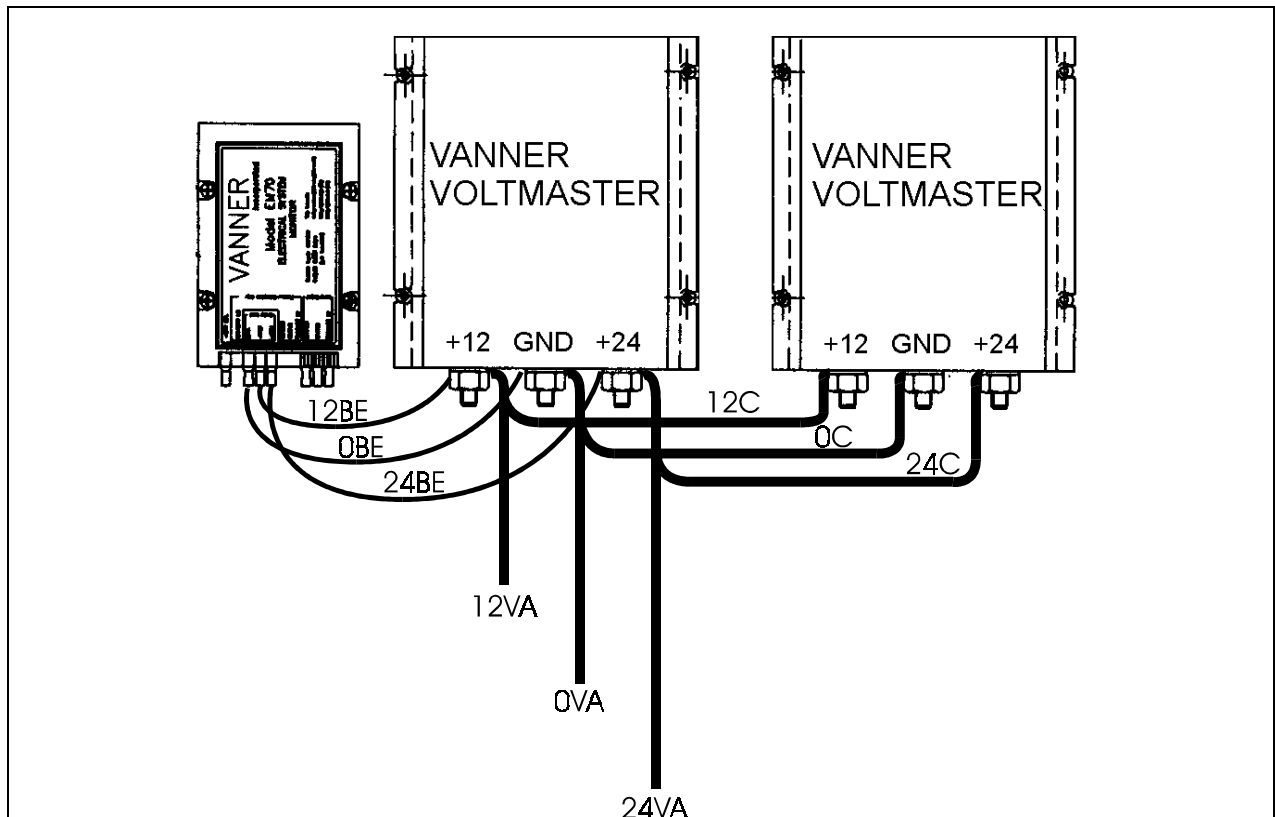

FIGURE 2 : CONNECTIONS FOR TWO 60A EQUALIZERS CONFIGURATION

SUPPLEMENT - ADDING FUSES TO WIRES 12BE AND 24BE

DESCRIPTION

If the electrical system monitor on your vehicle has no power surge protection, it is necessary to add fuses to the electrical supply of the monitor. Doing so will effectively protect it against any such damage.

MATERIAL

Part No.	Description	Qty
563061	In-line fuse holder	2
562599	Fuse, blade 3A violet	2
561539	Tab terminal receptacle	4
561540	Tab terminal	4

Note : Material can be obtained through regular channels.

PROCEDURE

Warning : Park vehicle safely, apply parking brake, stop engine and set battery master switch(es) to the OFF position prior to working on the vehicle.

1. Crimp a tab terminal on one lead end of each ATO in-line fuse holder. Crimp a tab terminal receptacle on the other end. Install a fuse in each of the fuse holders.
2. Access the Vanner electrical system monitor. Refer to figures 3 to 5 for possible locations.

Caution : Because the electrical system monitor is connected directly to the batteries, it is recommended to use caution when manipulating live wires to prevent any shorts;

3. Find wires 12BE and 24BE leading from the monitor and disconnect.
4. Connect one fuse assembly in series with wire 12BE and one with wire 24BE. Reconnect other ends to the electrical system monitor.

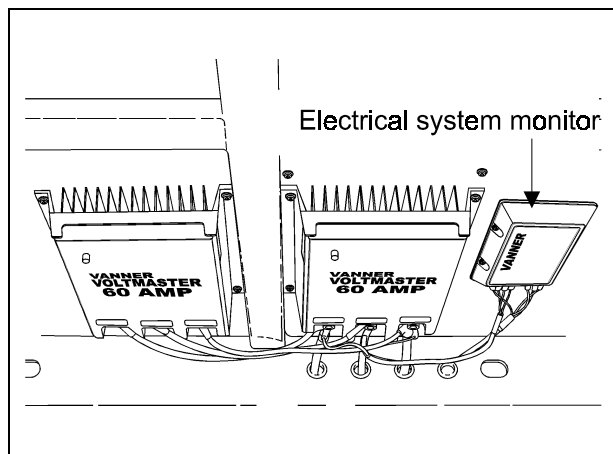

FIGURE 3: LEFT REAR BAGGAGE BAY

06326

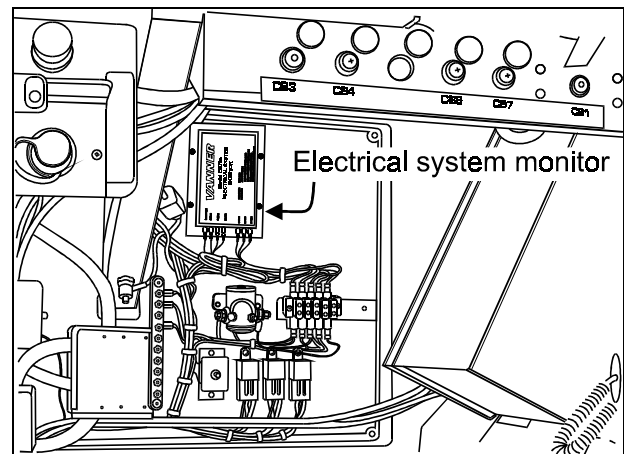

FIGURE 4: MAIN POWER COMPARTMENT

18392

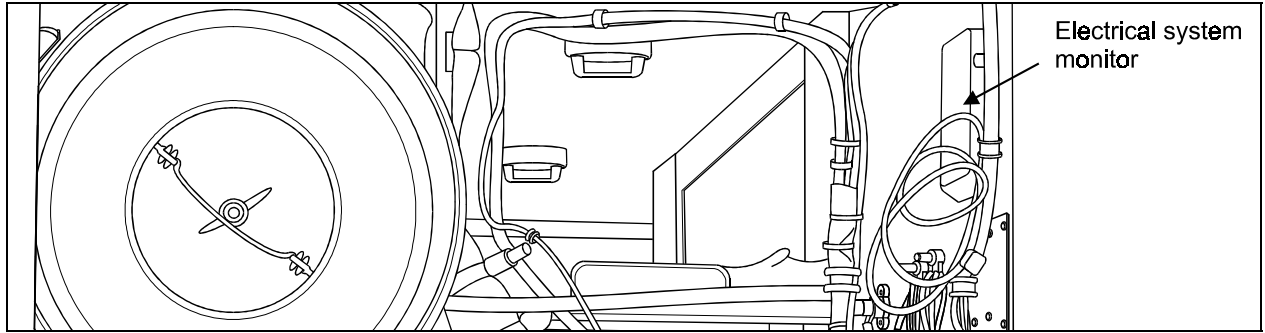

FIGURE 3: ENGINE COMPARTMENT

18354

Note : Add figure 6 to your wiring diagram as a reminder.

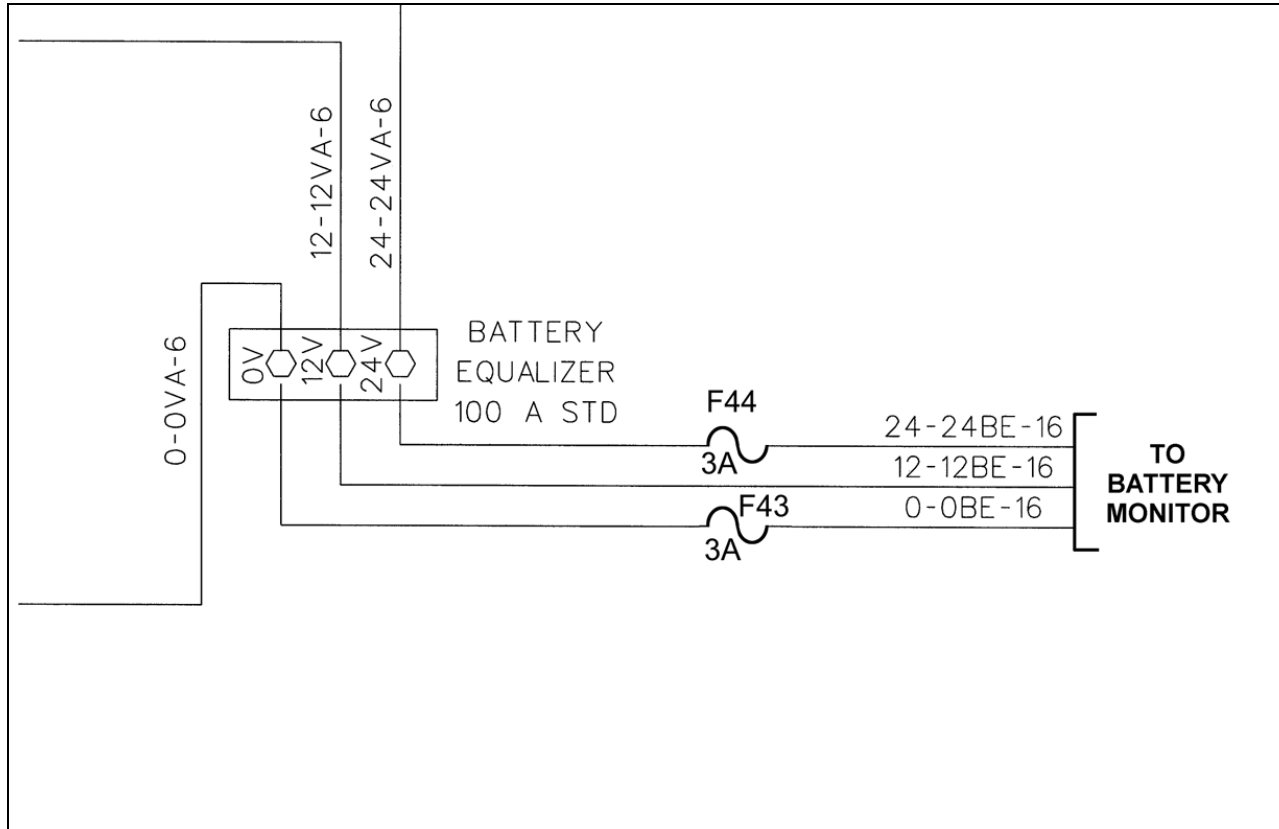

FIGURE 6 : ADDING FUSES TO WIRES 12BE & 24BE