

PREVOST

ENREGISTRÉ - REGISTERED
ISO 9001 & ISO 14001

SAFETY RECALL

Sr06-10



DATE : OCTOBER 2006	SECTION : 12
SUBJECT : BENDIX® SR-7™ SPRING BRAKE MODULATING VALVE	

APPLICATION

Model	VIN	
H3-41 and H3-45 coaches MODEL YEAR: 2006	2PCH3349161010604, 2PCH3341061010605, 2PCH3349561010606, 2PCH3349761010607, 2PCH3349061010609, 2PCH3349761010610	
X3-45 coaches MODEL YEAR : 2007	2PCG3349071028959, 2PCG3349771028960, 2PCG3349071028962	
This Safety Recall does not necessarily apply to all the above-mentioned vehicles, some vehicles may have been modified before delivery. The owners of the vehicles affected by this recall will be advised by a letter indicating the Vehicle Identification Number (VIN) of each vehicle concerned.		

DESCRIPTION

Bendix® and the National Highway Traffic Safety Administration (NHTSA) have determined that there is a safety concern which relates to the spring brake valve installed in certain 2006 H3-41 & H3-45 coaches, and 2007 X3-45 coaches.

Bendix has determined that a check valve inside the Bendix® SR-7™ spring brake modulating valve may not properly seat, causing internal valve leakage. The leakage can result in delayed application of the spring brakes to park the vehicle upon pulling of the dash valve button. The delay, which could last up to three minutes, may be accompanied by secondary air leakage, such that the secondary reservoir is depleted. During this time, there is a risk that the vehicle can roll away. This issue does not affect the operation of the vehicles service brakes, however it could affect the emergency stopping distance in the event of a primary air system failure application of parking brakes.

Perform the steps indicated in **SR-7 Valve Recall Campaign Identification Guidelines (BW2585)** included with this Safety Recall to check if the SR-7™ spring brake modulating valve installed in your vehicle is subject to this recall campaign. **Only if the spring brake valve is identified as subject to this recall, perform procedure described in this bulletin to replace it with a new unit.**



CAUTION

Warranty will reimburse only the SR-7™ spring brake modulating valves identified as subject to this recall. Before proceeding to a replacement, check if your valve is subject to this safety recall (refer to BW2585).

PROCEDURE



DANGER

Park vehicle safely, apply parking brake, stop engine and set battery master switch(es) to the OFF position prior to working on the vehicle.

VALVE REMOVAL

1. Drain all vehicle reservoirs.
2. The spring brake valve is located above the drive axle, behind the L.H. side hinged rear fender (Refer to figure 2 for H3 vehicles) or in the rear underframe (Refer to figures 3 & 4 for X3-45 coaches).

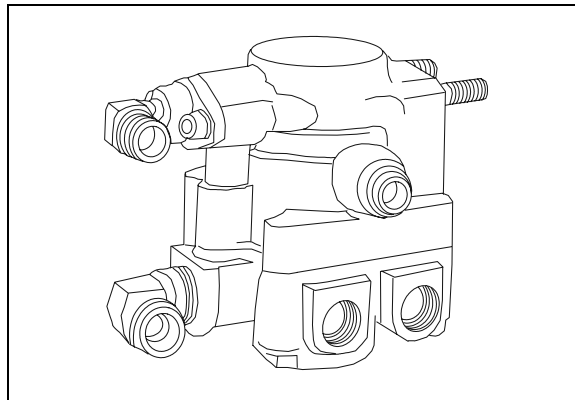

FIGURE1: SR-7 VALVE

3. Remove the L.H. side hinged rear fender or raise the vehicle to access the spring brake valve.
4. Identify all lines before disconnecting then disconnect the lines and hoses from the spring brake valve.
5. Remove the two mounting nuts that secure the valve to the frame rail then remove the valve.

VALVE INSTALLATION

1. Align the mounting studs with the mounting holes on the vehicle frame rail. Tighten the mounting nuts to 180-220 inch-lbs.
2. Install the valve (642015) onto the vehicle ensuring all ports are connected as marked during disassembly.

In order to verify and document the corrective action taken on your vehicle(s) pursuant to the requirements of the Federal Motor Vehicle Safety Regulations, we are enclosing a **"SAFETY RECALL CERTIFICATION" sheet**. When the vehicle(s) is (are) repaired, this (these) sheet(s) must be completed and returned to PRÉVOST CAR INC. head office.

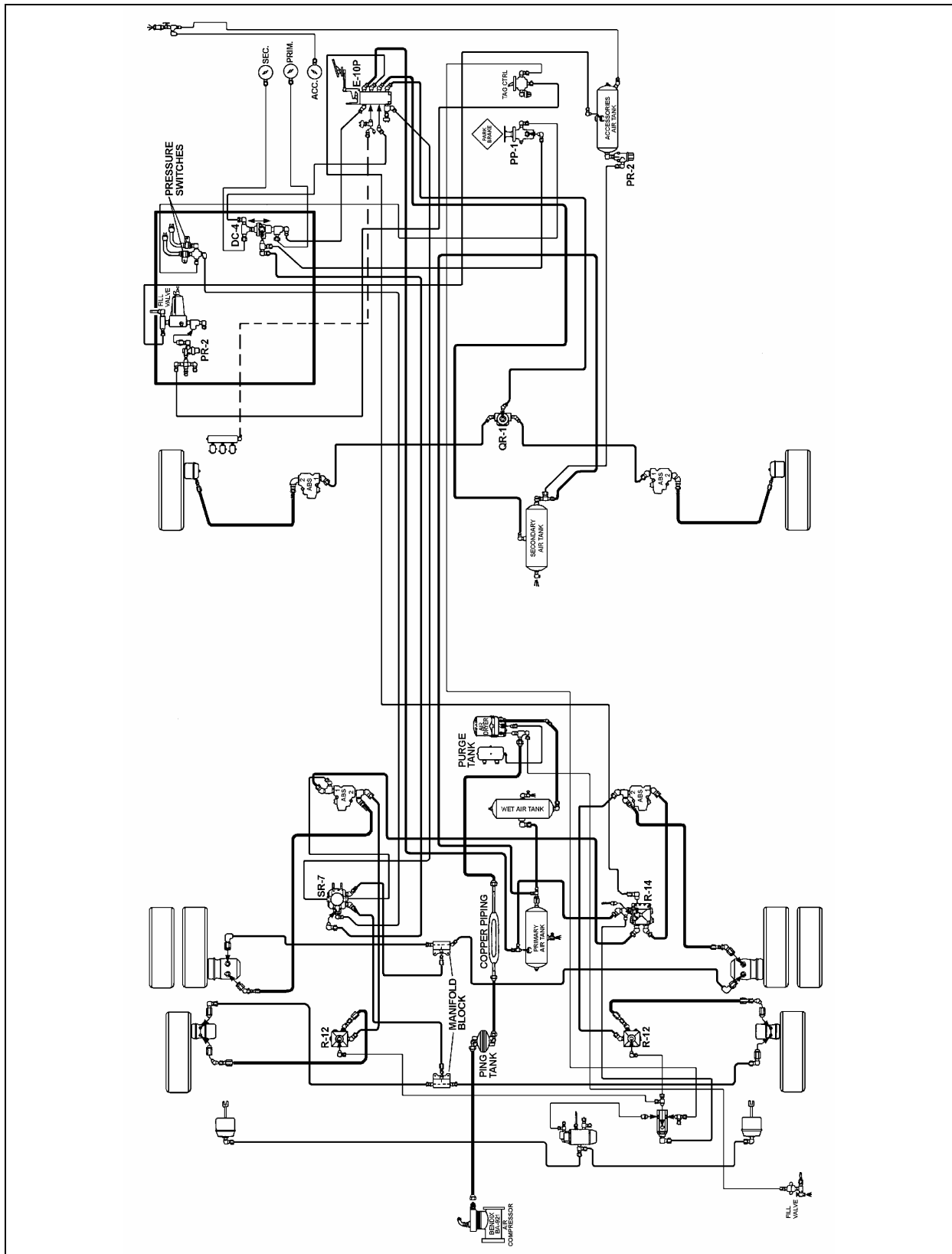

FIGURE 2: AIR-OPERATED BRAKING SYSTEM H3

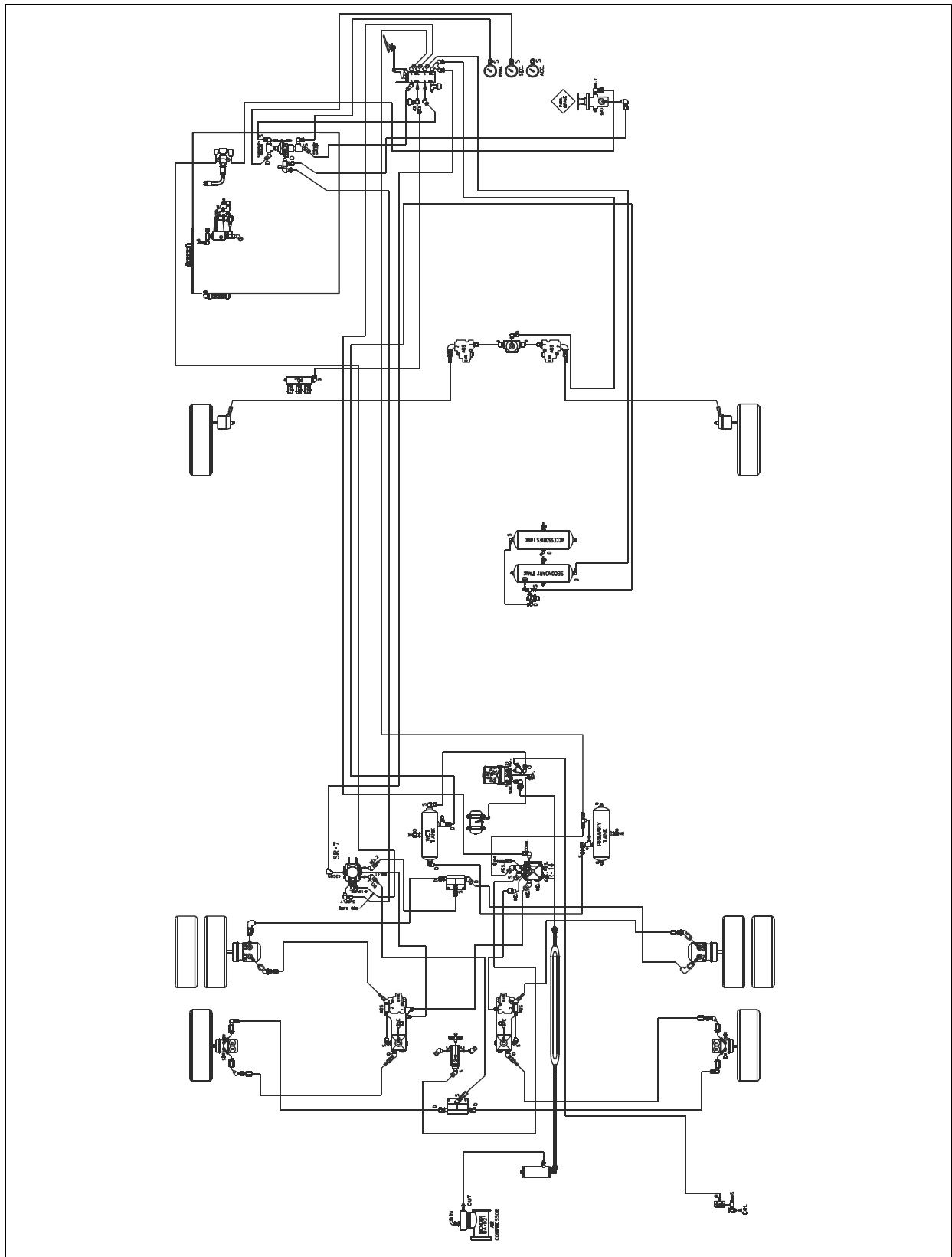

FIGURE 3: AIR-OPERATED BRAKING SYSTEM FOR X3 COACHES EQUIPPED WITH I-BEAM AXLE FRONT SUSPENSION

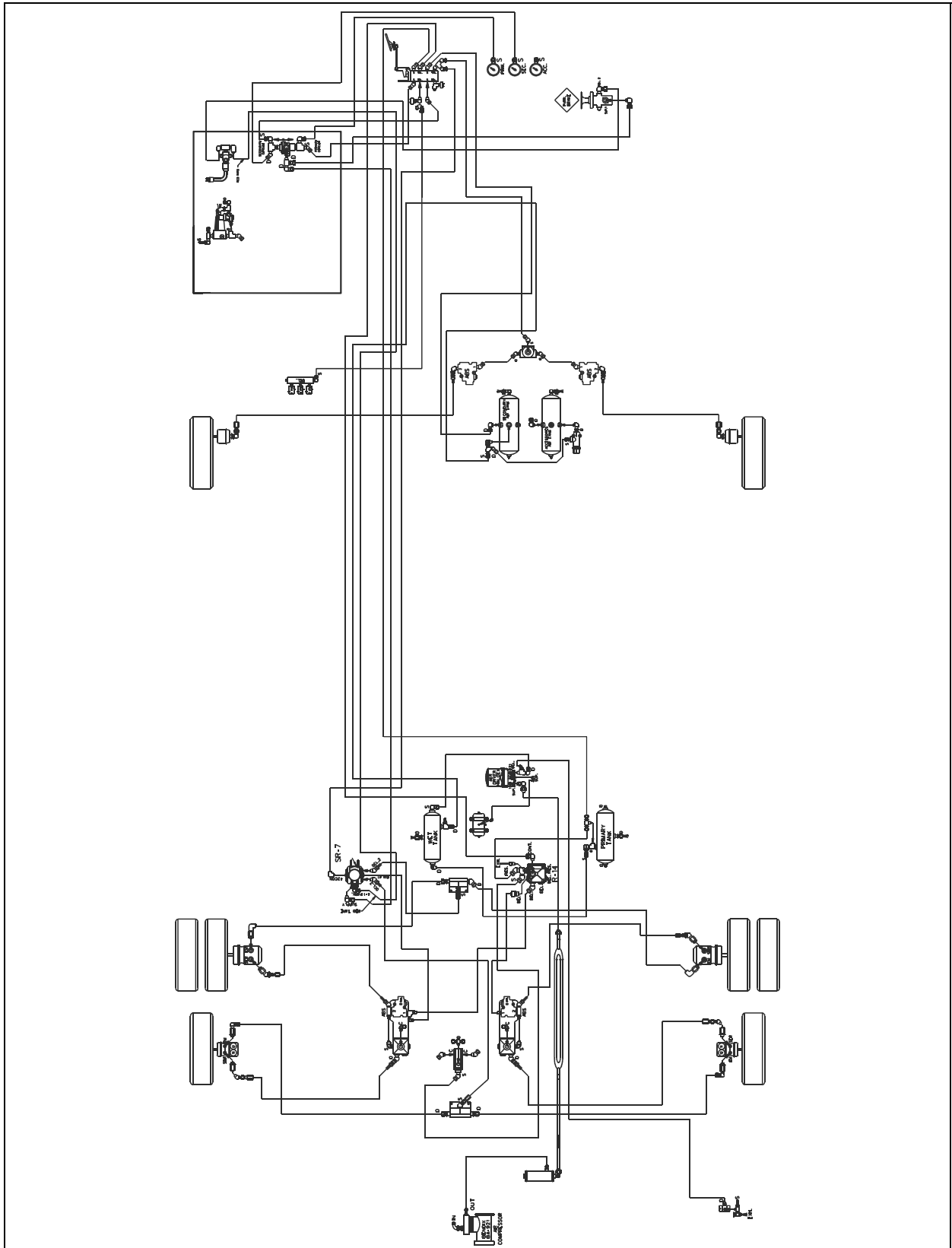

FIGURE 4: AIR-OPERATED BRAKING SYSTEM FOR X3 COACHES EQUIPPED WITH INDEPENDENT FRONT SUSPENSION 12216

WARRANTY

This modification is covered by Prevost Car's normal warranty. We will reimburse you the parts and one hour (1.0) of labor upon receipt of the parts and a completed A.F.A. form on which you must specify as per "Safety Recall 06-10". **You also have to fill the "Safety Recall Certification Sheet" provided with this bulletin and return it with your A.F.A. form to be reimbursed.**

Parts disposition:

- Return to Prévost Car with A.F.A. for full reimbursement.

Bendix® SR-7™ Valve Recall Campaign Identification Guidelines

June 1, 2006

This easy-to-follow guide is to be used to identify those SR-7™ valves that are subject to the recall campaign.

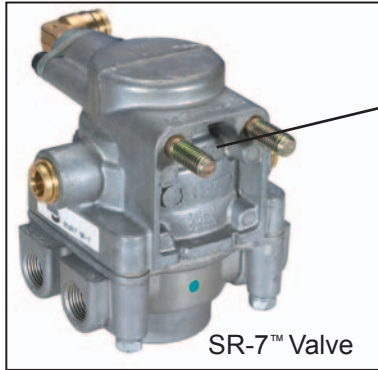

Step 1: Identify the casting as either **Bendix 1** or **Bendix 2**.
(Located on the side of the valve as shown.)



If the casting has "**Bendix 1**" on the side, it is potentially affected by the recall campaign and must be further identified.

Go to Step 2.

If the casting has "**Bendix 2**" on the side, it is not affected by the recall campaign, and no further action is required.

STOP

Step 2: Identify the date of manufacture.
(Date code located on the top of the valve as shown.)

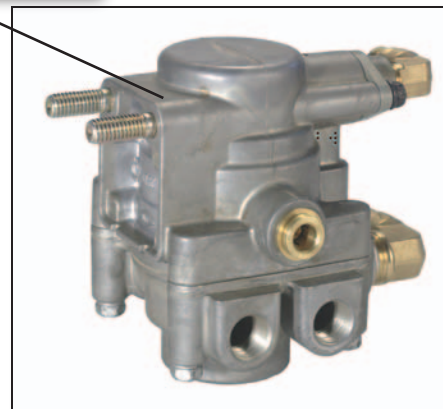

SR-7™ valves with the casting code "Bendix 1" manufactured between April 1, 2006 and May 24, 2006 are subject to the recall campaign and must be replaced.

To identify the date of manufacture go to the "Manufacturing Date Code Interpretation" on the next page.

Bendix

Manufacturing Date Code Interpretation

Date Code Location

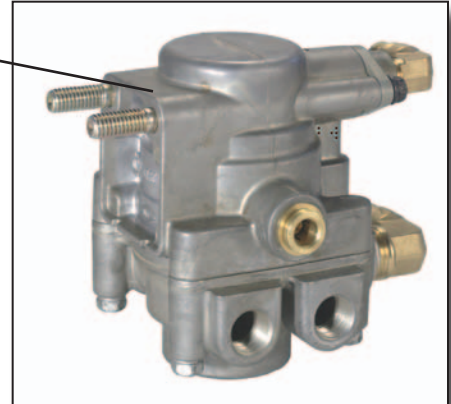

Manufacturing Date Code Interpretation:

The key date code characters used for identification are the 2nd through the 6th alphanumeric characters; all others can be disregarded.

The second character in the date code is an alpha character representing the month of manufacture (A through M skipping the letter I) corresponding to January through December (D = April and E = May). The next four characters are numbers representing the two digit day of the month followed by the two digit year. For example the date code 1C0706T, key characters C0706, indicates the valve was manufactured 3-07-06 or March 7, 2006.

SR-7™ valves with a casting code “Bendix 1” and the following date codes are subject to the recall campaign and must be replaced per the SR-7™ Recall Campaign Guidelines.

D0106 (April 1, 2006) through _E2406_ (May 24, 2006) inclusive.

SR-7™ Valve Part Number Reference

All SR-7™ valve part numbers are potentially affected by the campaign. For ease of reference a part number listing of all the valves are shown here.

OE Part Number	Service Part Number
5010914	801329
5010915	
5010916	
5010917	
5011180	
5012045	
5012046	
5012100	801328
5012472	801536
5012489	801328
5012568	
5012569	801569
5012615	801570
5012616	801571
5012831	801536
5013055	801329
5015302	802538
5016270	801571
5016271	801898
5017103	
5017233	801329



PREVOST

**Safety Recall
Certification Sheet
(Ref: Sr06-10)**

ENREGISTRÉ - REGISTERED
ISO 9001 & ISO 14001



SERIAL NUMBER: _____

PERFORMED BY		OWNER/OPERATOR	
We hereby certify that Safety Recall Instructions with regard to Safety Recall #06-10 have been performed.			
Name: _____		Name: _____	
Addr: _____		Addr: _____	
Phone: _____		Phone: _____	
Fax: _____		Fax: _____	
Signature :	_____	Signature :	_____
Date:	_____	Date:	_____

If the information mentioned above is incorrect or you are not the owner of this vehicle anymore, please fill this section and return to sender..

NEW OWNER: _____

BUSINESS: _____

ADDRESS (including County): _____

TELEPHONE: _____ **FAX:** _____

**Please return this completed document with your
A.F.A. form**