

PREVOST

**WARRANTY
BULLETIN**

Wb97-26



DATE: January 1998	SECTION: 01
SUBJECT: EXHAUST PIPE RE-ENFORCEMENT	

APPLICATION:

Model	VIN
H3-41, H3-45 and VIP Model Year: 1994 - 1998	<p>All vehicles up to 2PCH33492W1012264 incl.</p> <p>Note: Re-enforcement bracket may have been factory-installed on some vehicles whose serial number is comprised between 2PCH33494V1012068 and 2PCH33499W1012262 incl. PLEASE VERIFY BEFORE ORDERING PARTS.</p>
XL-45 Coaches Model Year: 1995 - 1998	<p>All vehicles up to 2PCL33495W1026430 incl. except 2PCL33497W1026347 2PCL33499W1026351 2PCL33498W1026356 2PCL33495W1026363 2PCL33491W1026375 2PCL33499W1026379</p>

DESCRIPTION

On the above-mentioned vehicles equipped with **series 60 engine**, a support bracket is added onto the exhaust pipe to avoid breaking up at turbocompressor flange level.

MATERIAL

Part No.	Description	Qty
040517	Bracket, re-enforcement	1
540018	U bolt assembly	1

Note: Material can be obtained through regular channels.

PROCEDURE

Warning: Park vehicle safely, apply parking brake, stop engine and set battery master switch(es) to the OFF position prior to working on the vehicle.

1. Open engine compartment rear door(s).

Warning: Ensure engine parts are cool down before proceeding.

2. Remove air intake pipe (refer to fig. 1).
3. Remove the after CAC (Charger-Air-Cooler) air pipe (refer to fig. 1).
4. Remove two bolts which will be used to secure re-enforcement bracket (refer to fig. 2).

5. Install re-enforcement bracket (Prévost # 040517) and U bolt assembly (Prévost #540018) as shown in figure 2.
6. Torque both engine bolts to 43 - 54 lbf•ft (58 - 73 Nm) and tighten U bolt nuts.
7. Close engine compartment door(s).

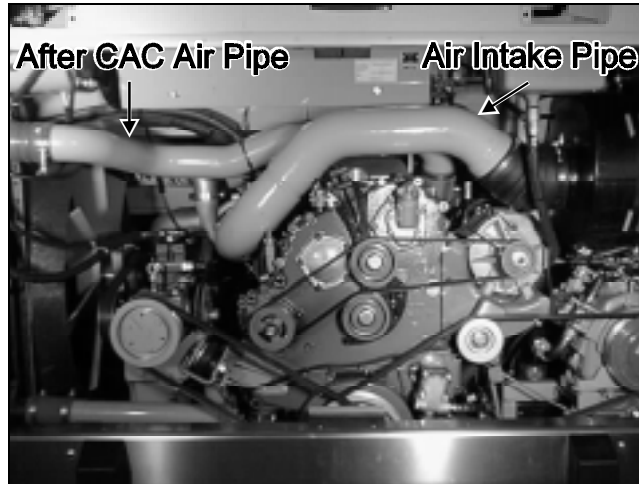

FIGURE 1: ENGINE COMPARTMENT

01042

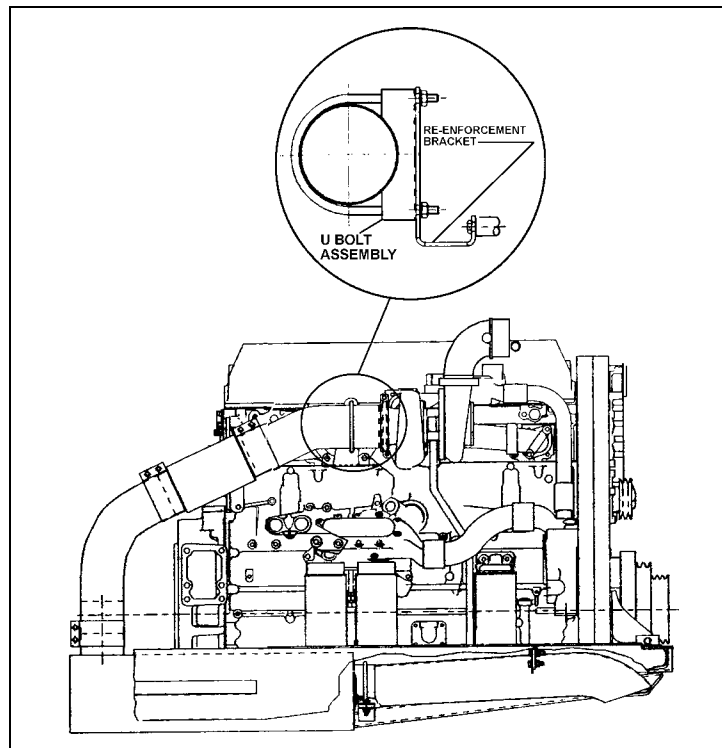

FIGURE 2: VIEW OF ENGINE - TURBOCOMPRESSOR SIDE

WARRANTY

This modification is covered by the manufacturer's normal warranty. We will reimburse you the parts and three quarters of an hour (0,75) of labor upon receipt of a completed A.F.A. form on which you must specify as per "Warranty Bulletin 97-26".

Expiration date: January 1999

PREVOST

Instruction Sheet

IS-97027

Bendix AD-9 Air Dryer

H3 Vehicles

MATERIAL

Kit #141940 includes the following parts.

Part No.	Description	Qty
641243	Air Dryer	1
501462	Reducer Coupling	2
501473	Elbow Coupling	1
501316	Reducer Coupling	1
641371	Elbow Coupling	1
501600	Reducer Coupling	1
641134	Elbow Coupling	2
501037	Elbow Coupling	1
141936	Support Plate	1
141937	Support Plate	1
500478	Washer	8
500783	Hexagonal Nut	8
500191	Bolt	4
500195	Bolt	4
503465	Tubing ¾ inch dia. 22 inch lg	1.833
IS-97027	Instruction Sheet	1
FI-97027	Feuille d'instructions	1

PROCEDURE

Warning: Park vehicle safely, apply parking brake, stop engine and set battery master switch(es) to the OFF position prior to working on the vehicle.

1. Safely support the vehicle at the axle jacking points.
2. Jack vehicle until the tires clear the ground, and place safety supports underneath body.

Warning: Only the recommended jacking points must be used as outlined in Section 18 of Maintenance Manual: "Body" or in Operator's Manual.

3. Remove right bellows splash guard. Drive axle right wheels may be removed if needed.
4. Bleed air from wet tank by opening drain valve located underneath tank (refer to fig. 1).

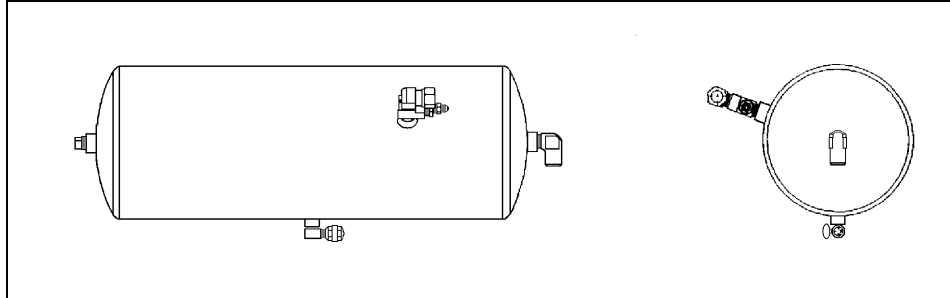

FIGURE 1: WET TANK

12104

5. Disconnect tubing and wire assembly from Wabco air dryer.
6. Separate Wabco air dryer from its support.
7. Remove tube coupling located on wet tank and replace with elbow coupling (Prévost #641134) making sure the opening is facing downwards.
8. Assemble Bendix AD-9 air dryer as per figure 2 and install support plate (Prévost #141936).

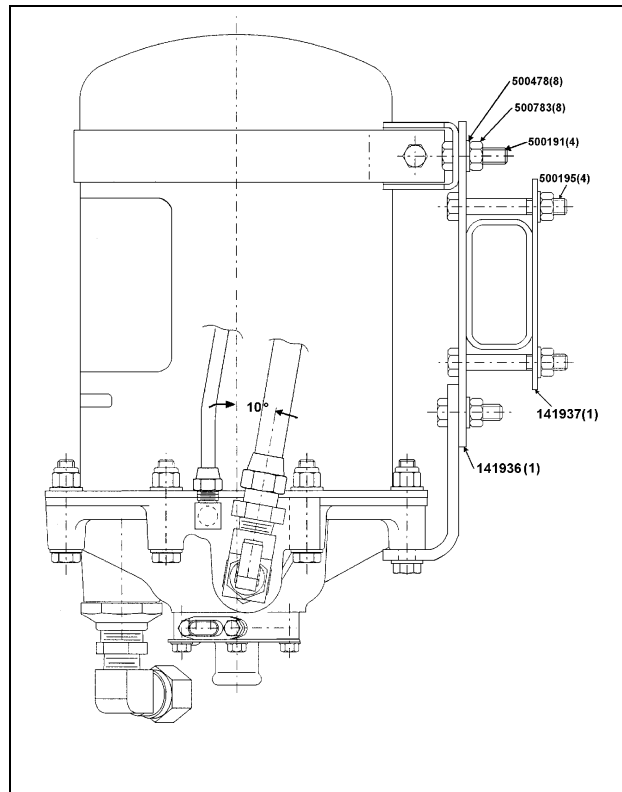

FIGURE 2: BENDIX AD-9 AIR DRYER

12105

9. Insert long bolts (Prévost #500195) through support plate (Prévost #141936) holes.
10. Install Bendix AD-9 air dryer on diagonal beam using top bolts to support the weight (refer to fig. 3).

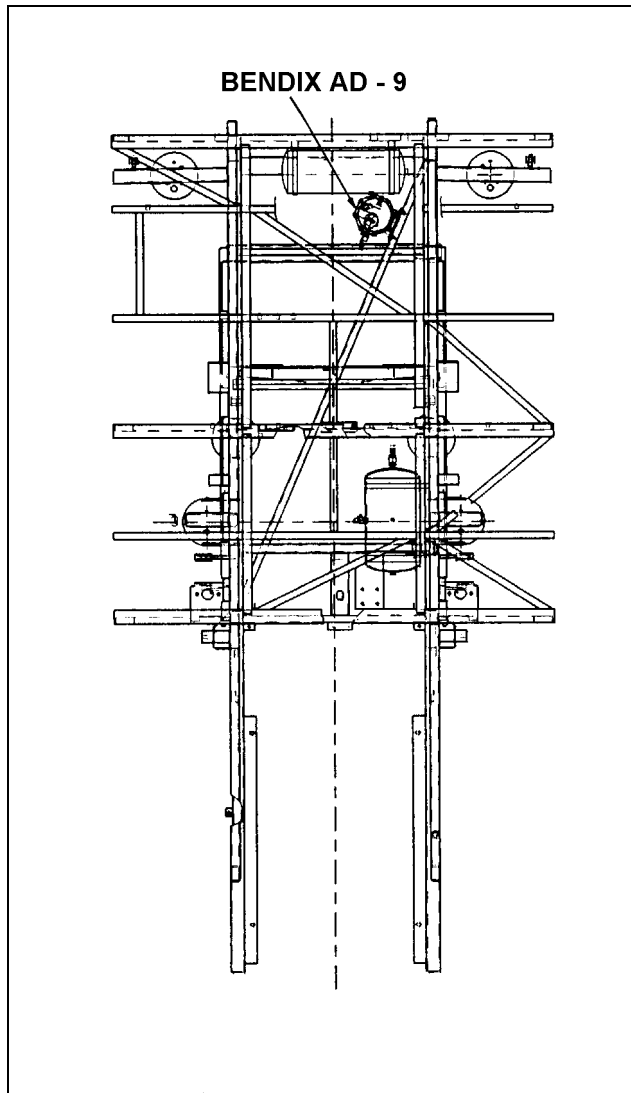

FIGURE 3: REAR SUBFRAME

12106

11. Install support plate (Prévost #141937) behind the beam and secure using washers and nuts (Prévost #500478 and #500783).
12. Reconnect tubing and wire assembly.
13. Install 22 inch long tubing (Prévost #503465) between air dryer and wet tank.
14. Close drain valve located underneath wet tank.

XL Series Coaches

MATERIAL

Kit #141941 includes the following parts.

Part No.	Description	Qty
641243	Air Dryer	1

501462	Reducer Coupling	1
507556	Female Tee Coupling	1
501316	Reducer Coupling	1
641371	Elbow Coupling	1
501600	Reducer Coupling	1
641029	Male Coupling	1
501037	Elbow Coupling	1
507339	Elbow Coupling	1
141938	Support Plate	1
500478	Washer	8
500783	Hexagonal Nut	6
500191	Bolt	8
503465	Tubing ¾ inch dia. 32 inch lg	2.667
501528	Elbow 45 ½ PM ½ PF	1
640995	Male Reducer Coupling ST #12 ½ PM	1
560482	Clamp	2
500641	Screw	2
IS-97027	Instruction Sheet	1
FI-97027	Feuille d'instructions	1

PROCEDURE

Warning: Park vehicle safely, apply parking brake, stop engine and set battery master switch(es) to the OFF position prior to working on the vehicle.

1. Safely support the vehicle at the axle jacking points.
2. Jack vehicle until the tires clear the ground, and place safety supports underneath body.

Warning: Only the recommended jacking points must be used as outlined in Section 18 of Maintenance Manual: "Body" or in Operator's Manual.

3. Bleed air from wet tank by opening drain valve located underneath tank (refer to fig. 6).
4. Disconnect tubing and wire assembly from Wabco air dryer.
5. Separate Wabco air dryer from its support.
6. Install support plate (Prévost #141938) on rear subframe beam, customer may choose to bolt or weld support plate (refer to fig. 4):

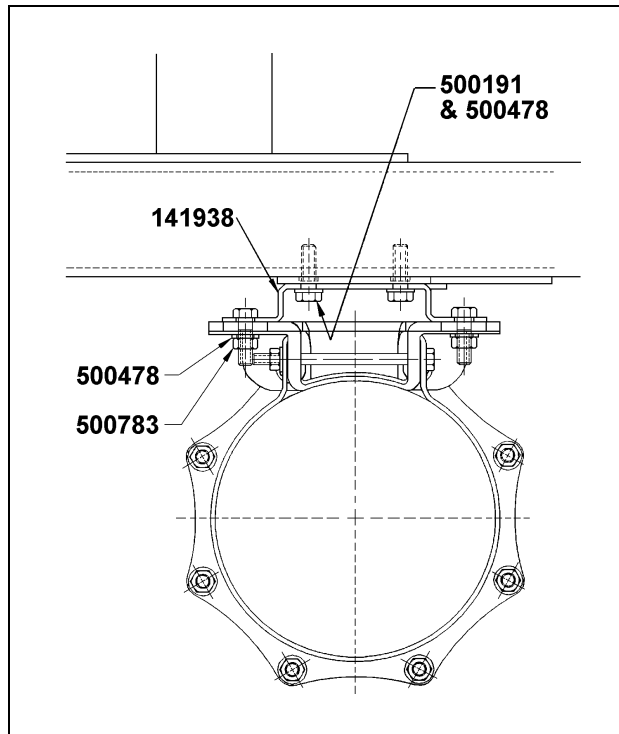

FIGURE 4: SUPPORT PLATE

12107

to bolt support plate:

mark position, drill two holes of 5/16 inch dia. in rear subframe beam and tap 3/8 in - 16 NC thread.

insert two bolts with washers (Prévost #500191 and #500478) in both tapped holes to secure top of support plate, bottom of support plate is secured with bolts, washers and nuts in two holes of already welded bracket used to mount Wabco air dryer.

to weld support plate:

install support plate (Prévost #141938) on existing bracket aligning bottom holes before welding.

7. Welding must be done only by a qualified and experienced person.
8. Protective shields must be placed in order to protect components against heat, welding flash, welding arc and other elements associated with welding.
9. Always wear the appropriate safety equipment.
10. Weld in clean and well-ventilated area, and always have an appropriate fire extinguisher within your reach.
11. The following precautions must be taken to protect the electronic control components :

Cut off battery power (battery master switch) from battery compartment.

Disconnect wiring harness connectors from ECM (Electronic Control Module). The ECM is mounted on the starter side of the engine.

For vehicles equipped with an automatic transmission, disconnect wiring harness connectors from ECU (Electronic Control Unit). The ECU is located in rear electrical compartment.

For vehicles equipped with ABS (Anti-Brake System), disconnect wiring harness connectors from ABS Electronic Control Unit. The ABS Electronic Control Unit is located in the front service compartment.

Do not connect welding cables to electronic control components.

12. Using a grinding wheel, remove asphalt base undercoating (gravel guard) from parts requiring welding.
13. Because of material thickness, it is recommended to use a semi-automatic electric arc welding in accordance with the following specifications:

STEEL - STAINLESS STEEL OR STAINLESS STEEL - STAINLESS STEEL WELDING

Note: Welding must be done only by a qualified and experienced person.

GMAW (Gaz Metal-Arc Welding) process;
welding wire conforms to AWS (American Welding Standards) A5.9 specifications;
308L type welding wire with 0.035" diameter (0,9 mm);
voltage: 18 volts to 22 volts;
current: 50 amperes to 200 amperes;
shielding gas: T90-H (90% helium, 7,5% argon, 2,5% CO²).

If necessary, with lots of precaution to avoid perforate material, it is possible, but not recommended, to use a conventional electric arc welding machine, in accordance with the following specifications:

SMAW (Shield Metal-Arc Welding) process;
welding rod conforms to AWS (American Welding Standards) A5.9 specifications;
308L-16 type welding rod with 3/32" diameter (2,4 mm);
current: flat - 40 amperes to 70 amperes
up - 35 amperes to 50 amperes
overhead - 40 amperes to 60 amperes.

14. Assemble Bendix AD-9 air dryer as per figure 5.

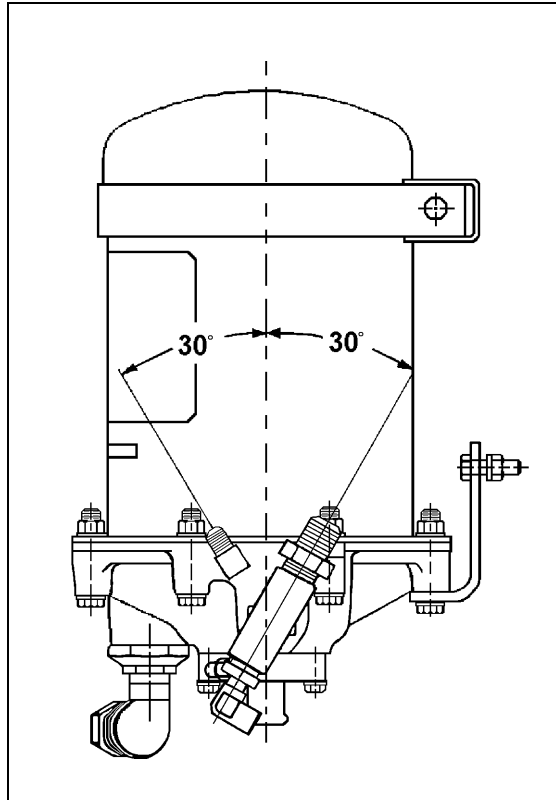

FIGURE 5: BENDIX AD-9 AIR DRYER

12108

-
15. Replace 90° elbow located on wet tank with a 45° elbow (Prévost #501528) plus male reducer coupling (Prévost #640995). Position 45° elbow to obtain 30° with reference to horizontal (refer to fig. 6).

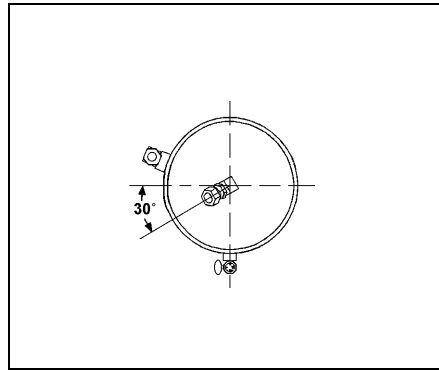

FIGURE 6: WET TANK

12109

16. Install air dryer on its support, bolt and reconnect tubing and wire assembly. Use supplied tubing (Prévost #503465) to connect air dryer with wet tank.

Note: Drill two holes of 5/32 inch dia. and use two clamps (Prévost #560482) with screws (Prévost #500641) to secure tubing so that no interference exist with rear suspension when suspension is lowered to maximum.

17. Close drain valve located underneath wet tank.