

PREVOST

ENREGISTRÉ - REGISTERED
ISO 9001 & ISO 14001

**WARRANTY
BULLETIN**

Wb99-27



DATE : AUGUST 1999	SECTION : 06 - Electrical
EXPIRATION: AUGUST 2000	
SUBJECT : PART A : RELOCATION OF VOLTAGE REGULATOR	
PART B : RELOCATION OF RELAY R39, R40 & R41	

DESCRIPTION

High ambient temperature and continuous operation of the condenser motor may affect operation and reduce service life of some specific components in the main power compartment. In order to preserve the components, it is necessary to relocate relay R39, R40 & R41. At the same time, the voltage regulator is relocated on the right-hand side wall in the main power compartment.

Note : *If you do not have the expertise to perform the present bulletin warranty bulletin, do not hesitate to go to your nearest Prevost Service Center.*

PART A : RELOCATION OF VOLTAGE REGULATOR

For this job, kit # 065275 is required. This kit includes harness # 0652665 and fastening hardware. Take note that all wires are identified and mounted with ring terminals.

Note : *Do not considerate this part of the bulletin if the modifications has already been done on your vehicle(s)*

APPLICATION

Model	VIN
H3-41 & H3-45 Coaches Model Year : 1998 – 1999	From 2PCH33496W1012218 up to 2PCH3349XX1012899 incl.
H3-45 VIP Bus Shells	From 2PCV33491W1012226 up to 2PCV33499X1012900 incl.

MATERIAL

Kit # 065275 includes the following parts :

Part No.	Description	Qty
065265	4 wires harness, 85F, 90F, 107 & 0AA	1
500440	Flat washer	4
500470	Lock washer	4
500658	Screw 10-24 X 3/4"	4

Note : Material can be obtained through regular channels.

PROCEDURE

Warning : Park vehicle safely, apply parking brake, stop engine and set battery master switch(es) to the OFF position prior to working on the vehicle.

1. Open the main power compartment door (figure 1).
2. Set the battery master switch to the "OFF" position (figure 2).

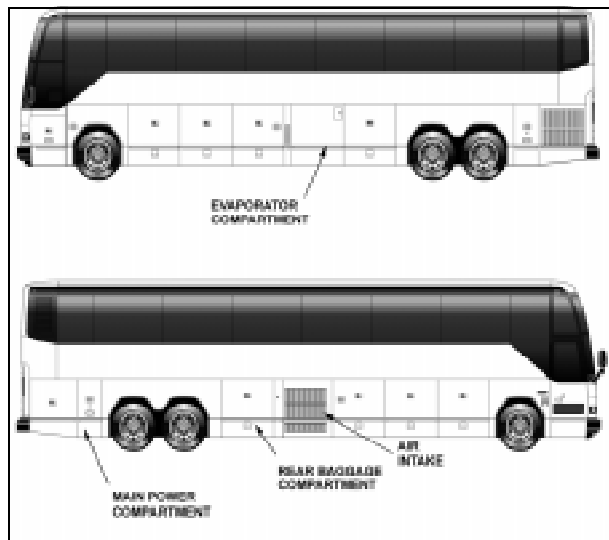

Figure 1 : location of compartments

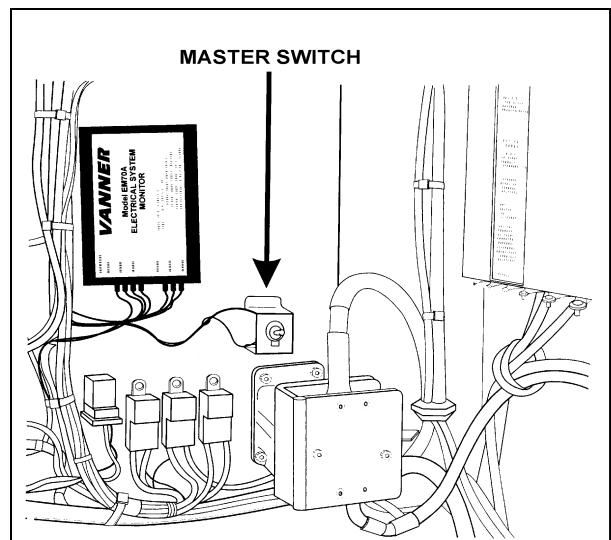

Figure 2 : main power switch

3. Locate the Delco Remy voltage regulator (figure 3).
4. With a flat screwdriver, disconnect wire 0AA, 107, 90F & 85F from voltage regulator terminals (figure 3).
5. Disconnect the other end of wire 0AA from ground stud. Open the cable ties and remove 0AA from the existing harness.
6. Reconnect the ring terminal of existing wire 107 to junction F of terminal board (figure 3).

7. Disconnect the other end of wire 90F from relay R4 terminal. Open the cable ties and remove 90F from the existing harness (figure 3).
8. Cut and isolate existing wire 85F with heat shrinkable sleeve (figure 3).
9. Remove voltage regulator and relocate on the right hand side wall, under the Battery Equalizer (figure 4).
 - a) place the regulator as shown on figure 5 and mark the position of holes for drilling.
 - b) drill four (4) holes 5/32" dia. and fix the regulator with 4 self-tapping screws 10-24 X 3/4", 4 flat washers and split washers.
10. Connect all wires from new harness # 065265 to regulator terminals. Use the harness end where all the ring terminals are the same size. Connect wire 0AA on GRD terminal, wire 107 on FLD terminal, wire 90F on BAT terminal and wire 85F on IGN terminal (figure 3).
11. Connect the other end of wire 0AA on the ground stud (figure 3).
12. Connect the other end of wire 107 to junction F of terminal board (figure 3).
13. Connect the other end of wire 90F on relay R4 terminal.

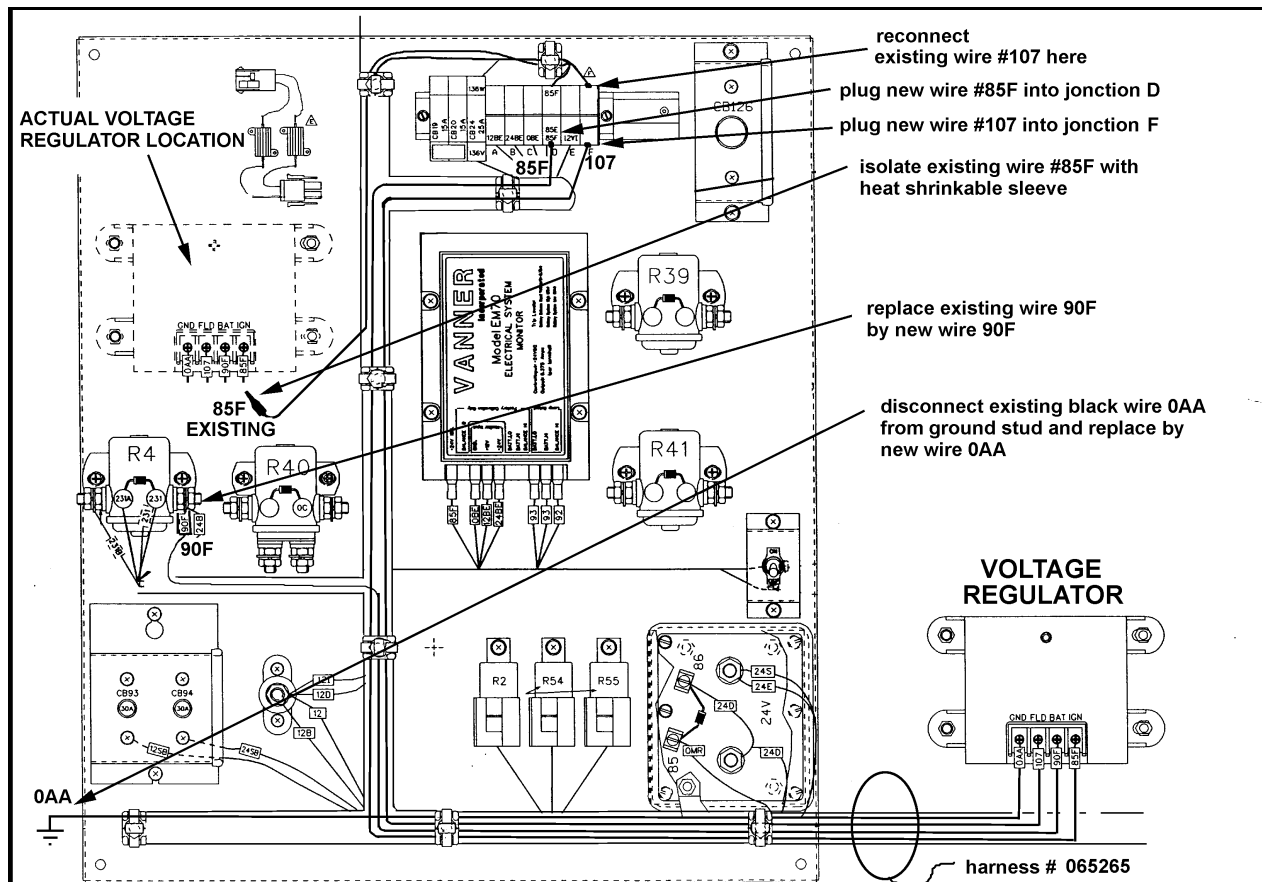

Figure 3 : relocation of voltage regulator

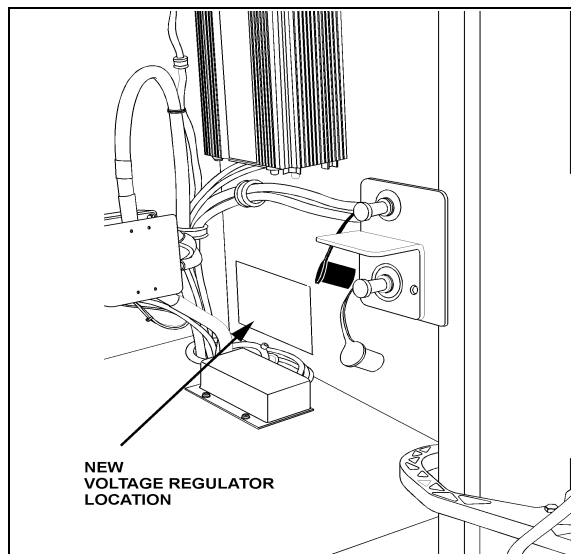

Figure 4 : voltage regulator location

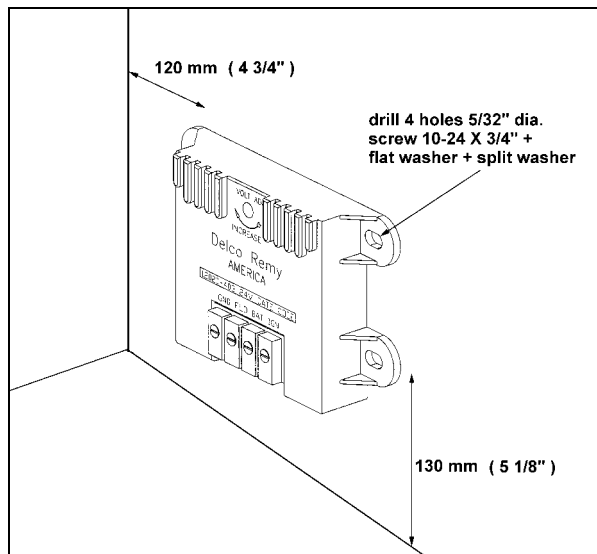

Figure 5 : voltage regulator positioning

14. Connect the other end of wire 85F to junction D of terminal board (figure 3).

15. Part A of this bulletin is now completed, proceed to part B.

PART B : RELOCATION OF RELAY R39, R40 & R41

Note : Do not considerate this part of the bulletin if the modifications has already been done on your vehicle(s)

APPLICATION

Model	VIN
H3-41 & H3-45 Coaches <u>with central A/C system</u> Model Year : 1997 – 2000	From 2PCH3349XV1011779 up to 2PCH33497Y1013414 incl.
H3-45 VIP Bus Shells <u>with central A/C system</u> Model Year : 1997 – 2000	From 2PCV33494V1011795 up to 2PCV3349XX1013425 incl.

MATERIAL

Kit # 065271 includes the following parts;

Part No.	Description	Qty
-	Relay assembly panel	1
065264	4 wires harness, 41, 42, 67K & 67L	1
562037	Ring terminal	1
562668	Ring terminal	3
500564	Screw 8-32 X 3/4"	6
560784	5" heat shrinkable sleeve	1
504637	Tie wrap	40

Note : Material can be obtained through regular channels.

PROCEDURE

Warning : Park vehicle safely, apply parking brake, stop engine and set battery master switch(es) to the OFF position prior to working on the vehicle.

1. Open the main power compartment door (figure 1).
2. Set the battery master switch to the "OFF" position (figure 2).
3. Locate on the upper right side of the back panel a four (4) wires harness wrapped with electric tape. These wires are identified 41A (red), 41B (red), 42A (red) & 0D (black) (figure 6).
4. Cut wires 41A, 41B, 42A & 0D and leave approximately 8" (20 cm) long (figure 6).
5. Read the warning below. Disconnect and remove wires 41 & 42 from circuit breaker CB77 & CB78 (figure 7).

Warning : There is no power on circuit breaker CB77 & CB78 terminals, but terminals of the other circuit breaker are powered up, proceed with care.

6. Disconnect and remove wires 0C & 0D from ground stud (figure 6).
7. Unplug connector C537 from resistances and remove the resistances (figure 6).
8. Remove all connections and wires from relay R39, R40, R41 terminals.
9. Remove the relays R39, R40 & R41.
10. Locate the end of harness # 065264 with the big ring terminals. Attach this end to wires 41A, 41B, 42A & 0D with electric tape.
11. In the rear baggage compartment, take out the plastic sleeve and pull out wires 41A, 41B, 42A & 0D to pass the new harness # 065264 from main power compartment to baggage compartment (figure 8).
12. In the main power compartment, connect wires 41 & 42 of the new harness # 065264 to circuit breaker CB77 & CB78 terminals(figure 7).
13. Plug connector C537 from the new harness # 065264 to the connector C537 on the back panel. Secure all wires with tie wraps and close the cable ties.
14. In the rear baggage compartment, pull out to complete the installation of harness # 065264 (figure 8).
15. Attach harness # 065264 and wires 41A, 41B, 42A & 0D all along the baggage compartment ceiling (figure 9).
16. Open the evaporator compartment door (figure 1).
17. Locate the relay assembly panel to 30mm (1 ¼") approx. from compartment ceiling and 80mm (3 ¼") approx. from external edge of stile. Remove the cable ties (figure 10) and mark out the holes and drill 6 holes 1/8" dia. (figure 10)
18. Install the relay assembly panel with 8-32 X ¾" screws (figure 10).
19. Cut the tie wrap around the rubber wireway located between the evaporator compartment and the rear baggage compartment. Pass harness # 065264 and wires 41A, 41B, 42A & 0D through the wireway from baggage compartment to the evaporator compartment (figure 11).
20. Replace the tie wrap around the rubber wireway.
21. Plug connector from harness # 065264 to connector C537 on the relay assembly panel (figure 13).
22. Connect wires 41 & 42 from harness # 065264 to terminals on relay R39 & R40 as shown on figure 13.

23. Connect black wires 0C & 0D from relay assembly panel to the ground stud (figure 13).
24. Cut wire 0D of harness # 065264 long enough to reach the ground stud. Place a 1" long heat shrinkable sleeve and fix a big ring terminal. Connect to ground stud (figure 12 & 13).
25. Cut wires 41A, 41B & 42A to proper length, fix ring terminal and sleeve to each wires and connect to relay R39, R40 & R41 terminals as shown on figure 13.
26. Secure all wires with tie wraps and put back only one of the two cable ties in an appropriate place (figure 14).
27. Make sure that the diodes on the relays are not touching the casing (figure 13).

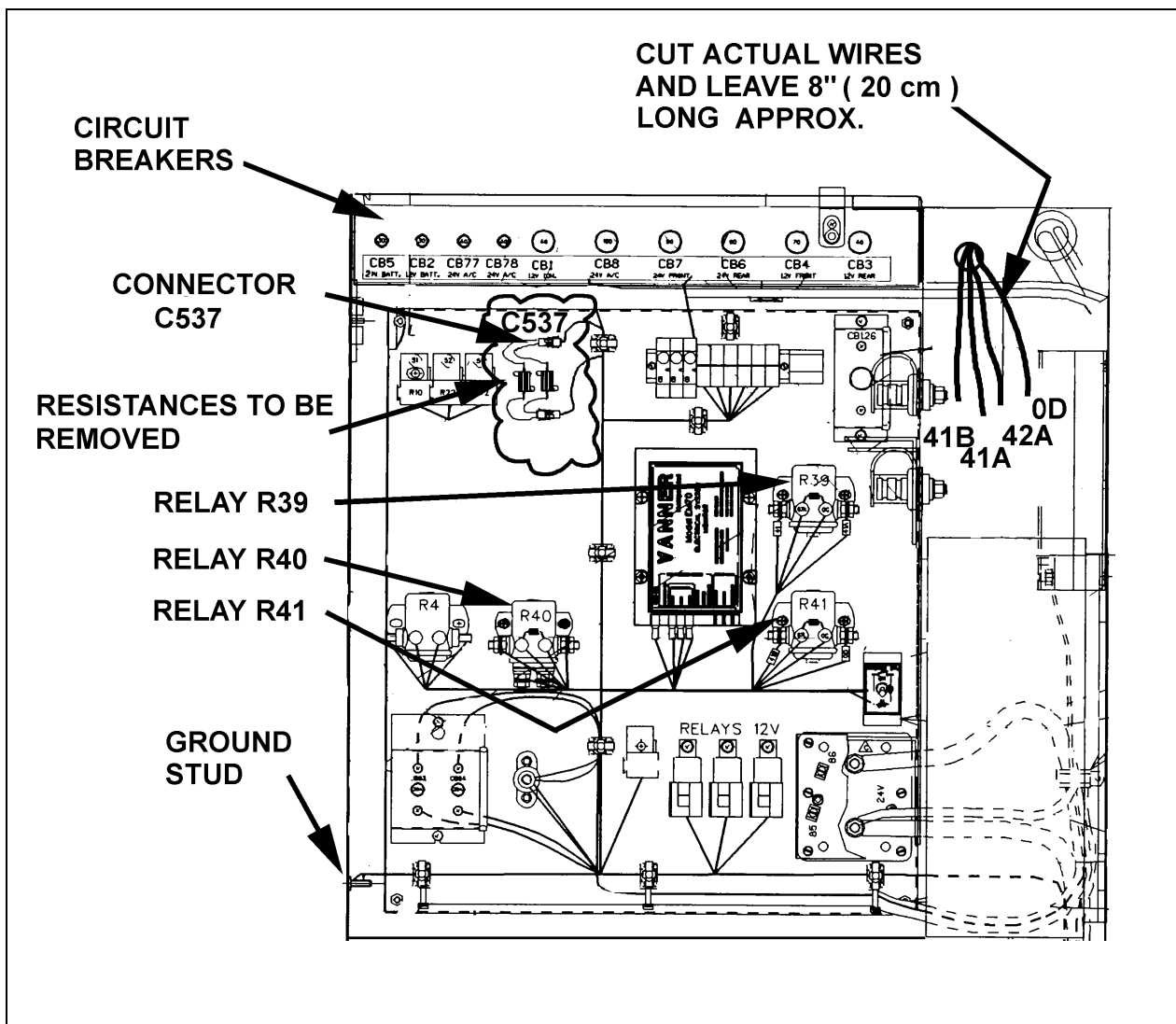

Figure 6 : main power compartment back panel

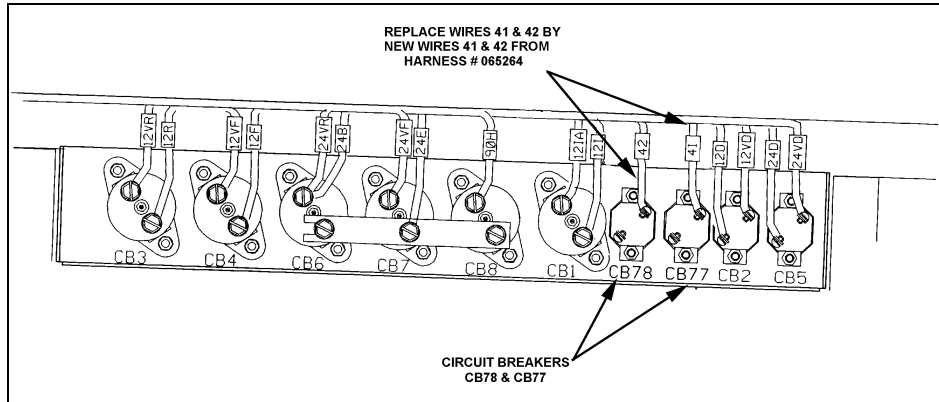

Figure 7 : rear view of the circuit breaker panel. There is no power on circuit breaker CB77 & CB78, but terminals of other circuit breakers are powered up, proceed with care.

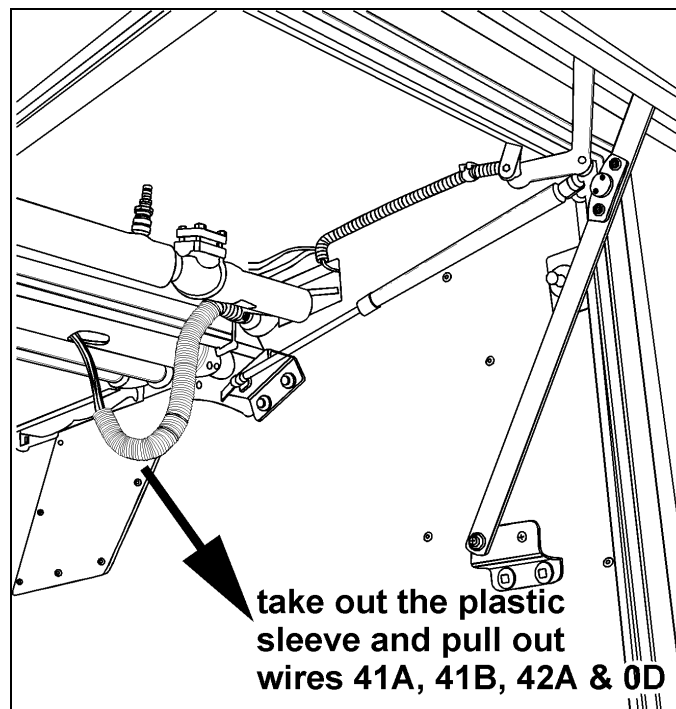

Figure 8 : view from inside the baggage compartment



Figure 9 : attach harness and wires all along the baggage compartment ceiling

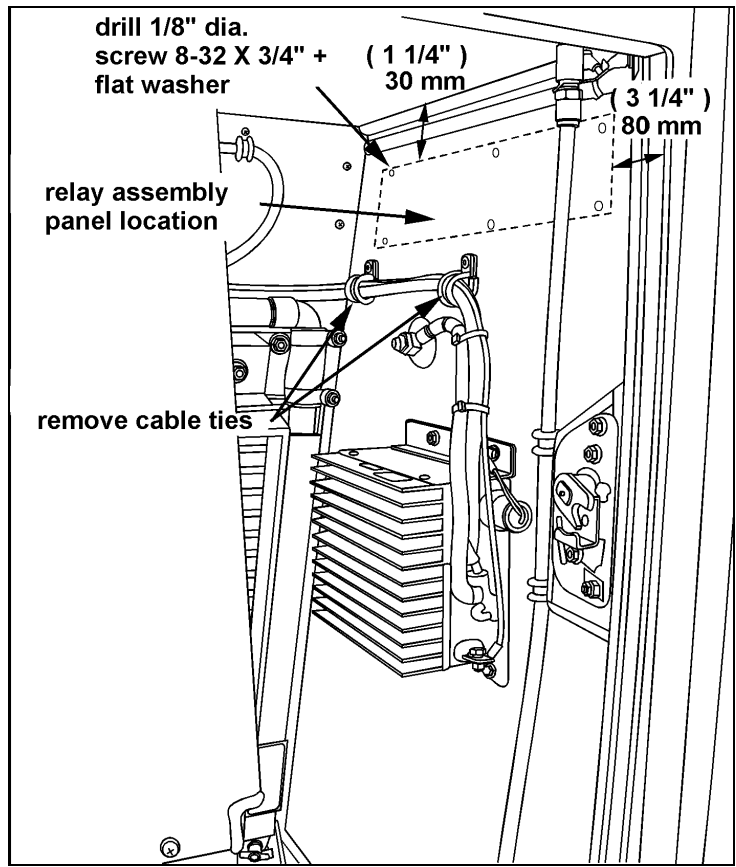

Figure 10 : location of relay assembly panel

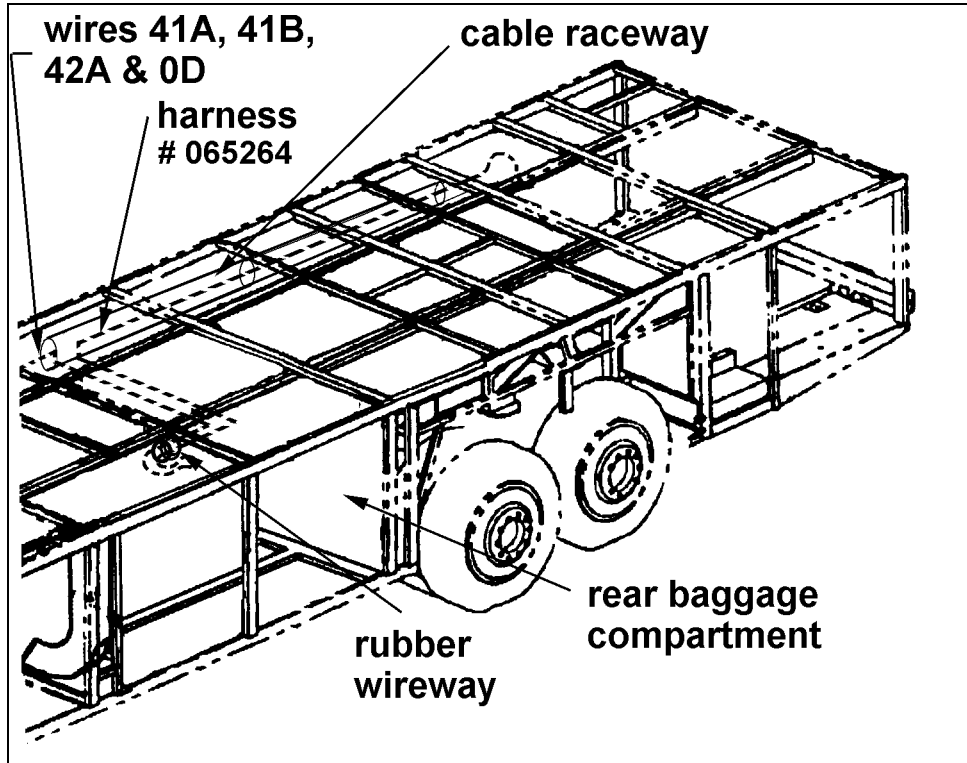

Figure 11 : circuit path

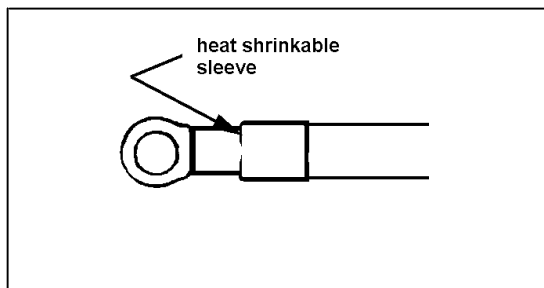

Figure 12 : ring terminal and wire assembly

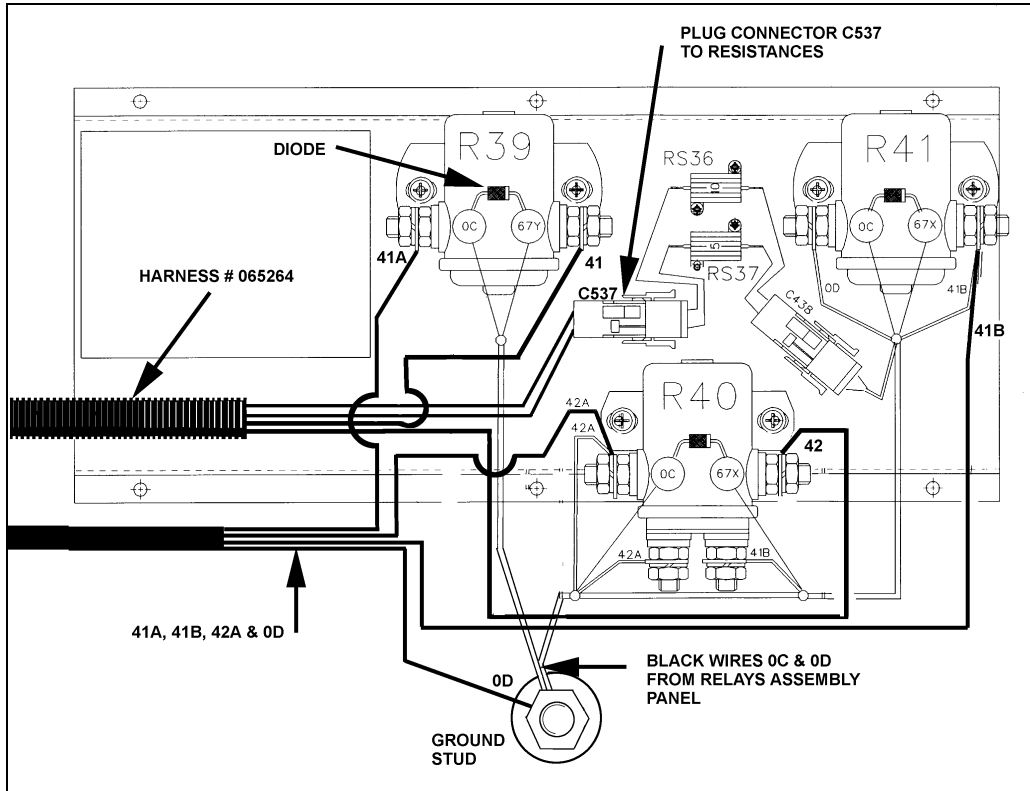

Figure 13 : relay assembly panel and circuitry

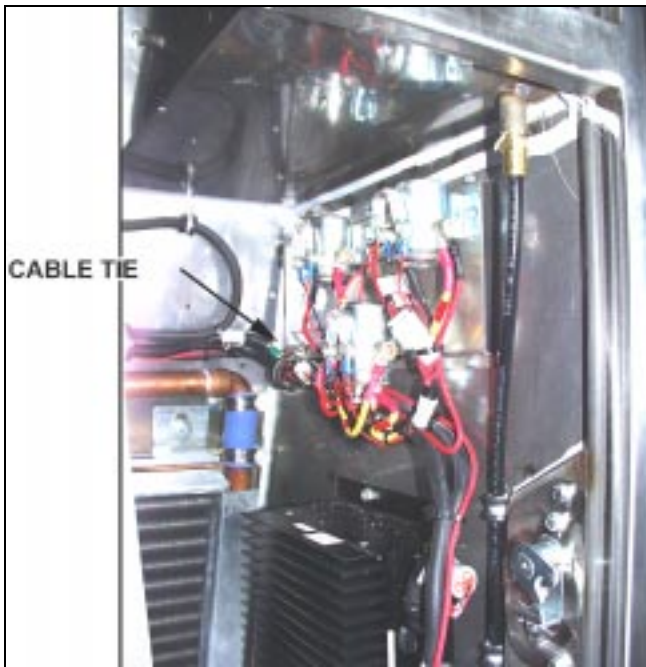

Figure 14 : completed installation

28. The installation is now completed. Close all compartment doors and set the battery master switch to the "ON" position (figure 2).

TEST

1. With the purpose of testing, start the engine and start the A/C system. Check that both of the condenser fans are running. They should be running on first speed.
2. Open the R.H. side door of motor compartment. Locate connector C159 under the compressor support. Disconnect C159 and jump the pins A & B inside the connector (figure 15). Condenser fans should be running on second speed. If not, check your installation circuitry.

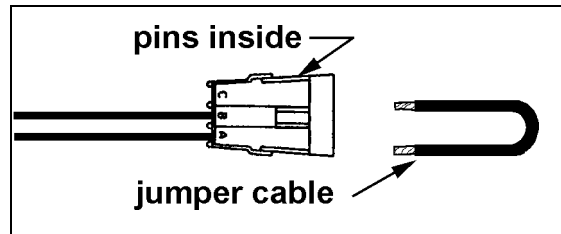

Figure 15 : connector C159

WARRANTY

This modification is covered by Prévost Car's normal warranty. We will reimburse you the parts and two and a half hours (2.5) of labor upon receipt of a completed A.F.A. form on which you must specify as per "Warranty Bulletin 99-27".

Parts disposition :

- Discard according to applicable environmental regulations (Municipal/State[Prov.]/ Federal)