

PREVOST

Instruction Sheet

IS-11135

PUMP FLANGE MODIFICATION FOR INSTALLATION ON NEW WASTE WATER TANK 406550 or 406551. H SERIES

Installation of new waste water tank requires drilling pump flange.

New tank has a tighter bolt pattern.

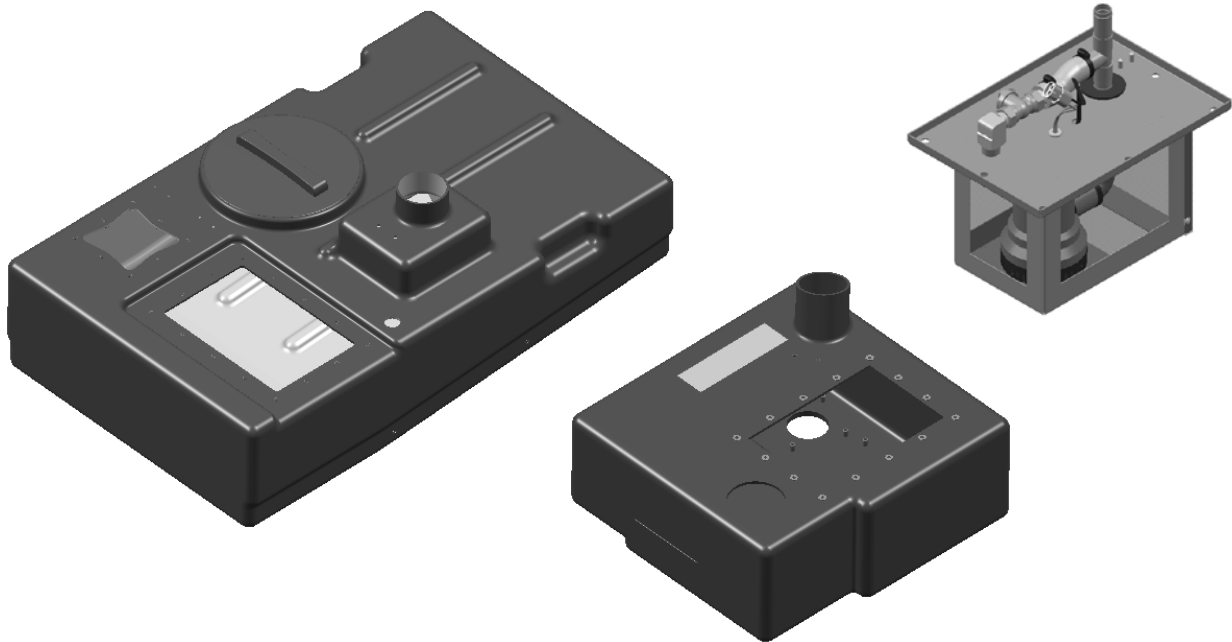

MATERIAL

Kit #406620 includes the following parts:

Part No.	Description	Qty
406550	Auxiliary waste water tank	1
406552	Gasket	1
502573	Washer 6mm SS	6
5001181	Bolt M6 x1.0 x 12mm SS	6
IS-11135	Instruction Sheet	1
FI-11135	Feuille d'instructions	1

Kit #406621 includes the following parts:

Part No.	Description	Qty
406551	Waste water tank	1
406552	Gasket	1
502573	Washer 6mm SS	6
5001181	Bolt M6 x1.0 x 12mm SS	6
IS-11135	Instruction Sheet	1
FI-11135	Feuille d'instructions	1

NOTE

Material can be obtained through regular channels.

PROCEDURE



DANGER

Park vehicle safely, apply parking brake, stop engine and set battery master switch(es) to the OFF position prior to working on the vehicle.

1. Disconnect all hoses going to the pump.
2. Remove existing pump.
3. Keep all mounting flange bolts and washers for re-use.
4. Turn the pump upside down. Install gasket on mating face of flange. Use corner holes to position gasket.

Mark new hole locations.

Confirm hole layout with supplied drilling pattern.

Drill 3/8" dia. holes in pump flange (6X).

5. Deburr sharp edges.
6. Install on new waste water tank using hardware reserved previously and supplied additional hardware.
7. Reconnect all hoses
8. Inspect for any leaks.

FLANGE DRILLING PATTERN, DIMENSIONS TO EXISTING HOLES

Not to scale.

Use supplied gasket for drilling template and confirm layout with dimensions shown below.

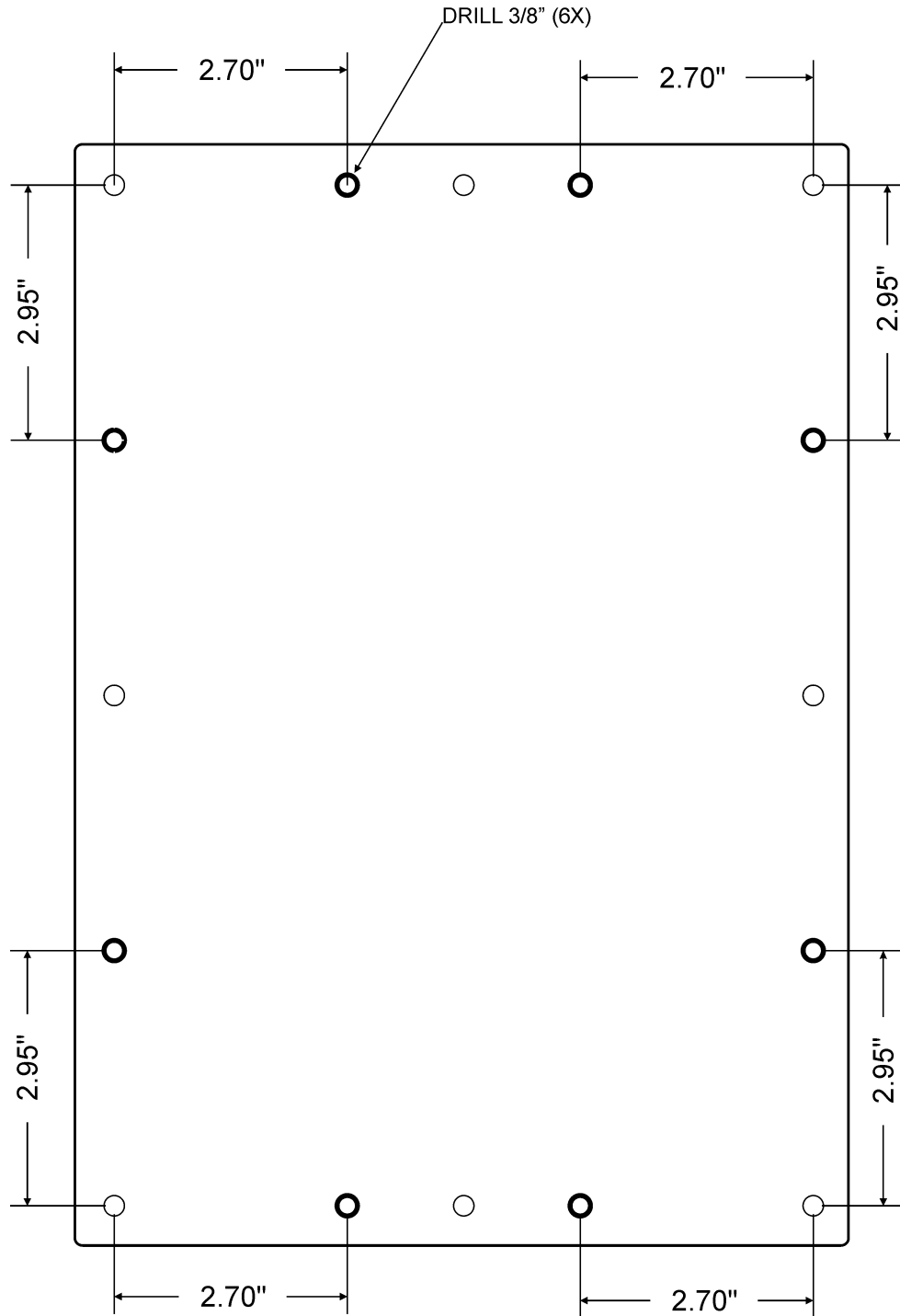

PARTS / WASTE DISPOSAL

Discard waste according to applicable environmental regulations (Municipal/State[Prov.]/ Federal)