

PREVOST





Instruction Sheet

IS-14904

CONDENSER PIVOT REINFORCEMENT PLATE

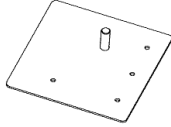
MATERIAL



Kit # 454964 includes the following parts:

Part No.	Description		Qty
454956	Reinforcement Plate		1
507260	Nylon Bushing		1
504379	Rivets 3/16 x 1/4"		4
504637	Cable tie		3
IS-14904	Instruction Sheet	-	1

Recommended equipment:

Material	Description	Note
	Drill bit set (135° tip)	1/8" to 1" (Sheet metal compatible with 135° tips)

	<p>Drill bit stoppers</p>	<p>to match the drill bits used</p>
	<p>1" sheet metal hole saw</p>	<p>With centering tip as short as possible (or adjustable).</p>
	<p>Electric Drill</p>	<p>1/2" shank recommended</p>
	<p>Angle Grinder (as required)</p>	<p>Electric or Pneumatic Use with metal cutting disk</p>
	<p>Socket wrench set</p>	<p>13mm and 24mm sockets required</p>
	<p>Pop rivet gun</p>	<p>Manual or pneumatic</p>
	<p>Cutting plier</p>	<p>Or suitable/equivalent tool</p>

 <p>9mm</p>	<p>9mm carbide grinding tool</p>	<p>Or SAE 11/32" equivalent tool</p>
	<p>Center punch</p>	<p>Automatic</p>
	<p>Lift table</p>	<p>Wheeled</p>

NOTE

Material can be obtained through regular channels.

PROCEDURE



DANGER

Park vehicle safely, apply parking brake, stop engine and set battery master switch(es) to the OFF position prior to working on the vehicle.

PART 1: CONDENSER PREPARATION

1. Open the condenser door by pulling the latch located in the fuel filler compartment (Fig.1 & 2).



Fig.1

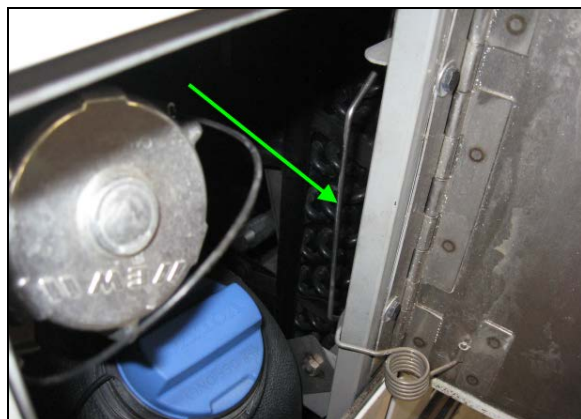

Fig.2

2. Disconnect the door limiter strap at the door end to allow complete opening of the door (Fig.3 & 4).



Fig.3

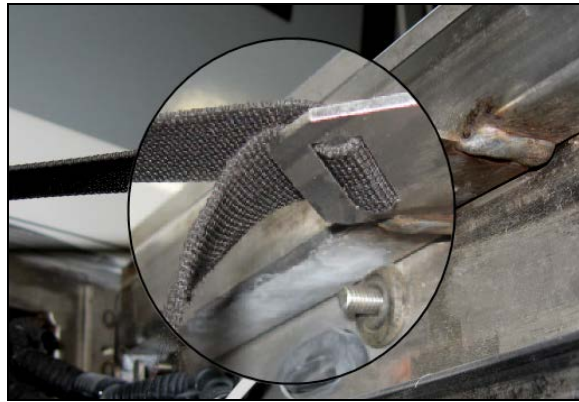

Fig.4

3. Pull the condenser latch and tilt the compressor 90deg out by pulling on the strap located on the side of the condenser (Fig.5 & 6).



CAUTION

Only the strap should be used to pull the condenser-fan assembly open. Damage to condenser could result if pulling by other means.

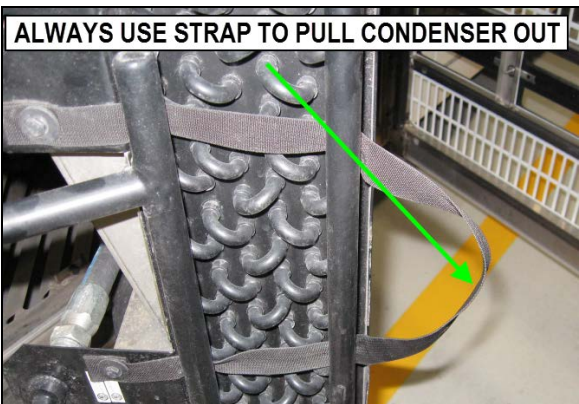

Fig.5



Fig.6

4. Put a hydraulic lift table under the condenser to support it. Lift slightly, just enough to remove weight on the lower support pivot (Fig.7 & 8).



Fig.7



Fig.8

5. Cut the cable tie on the top pivot bracket and the adjacent wiring harness (Fig.9).
6. Remove the bracket from the vehicle by unscrewing the two M8 hex bolts (13mm or 1/2" head) securing it to the frame (Fig.10).

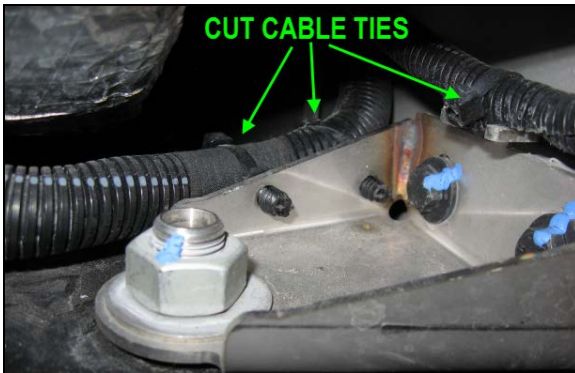

Fig.9

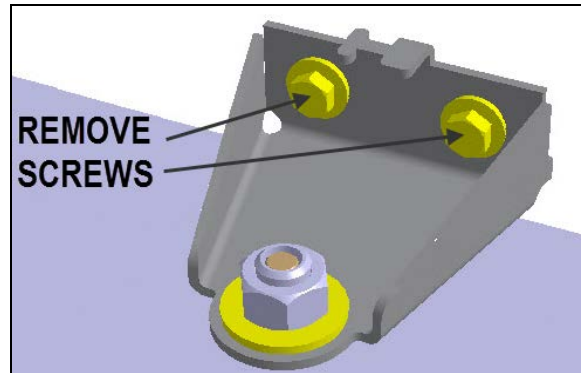

Fig.10

7. With the lift table, raise the condenser about an inch to disengage and clear the lower pivot pin (Fig.11 & 12).



Fig.11

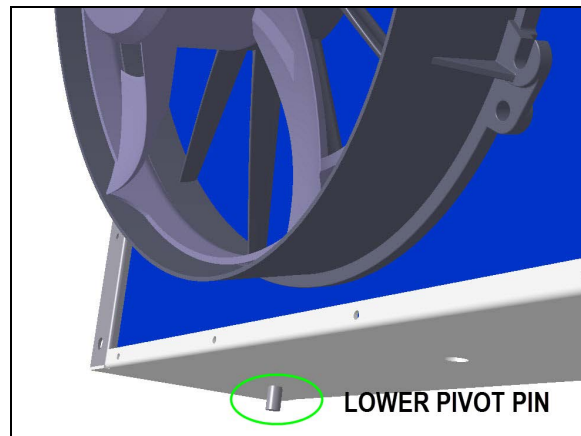

Fig.12

8. Pull away the condenser from the vehicle to allow sufficient clearance on the condenser top to install the reinforcing plate supplied in the kit (Fig.13).

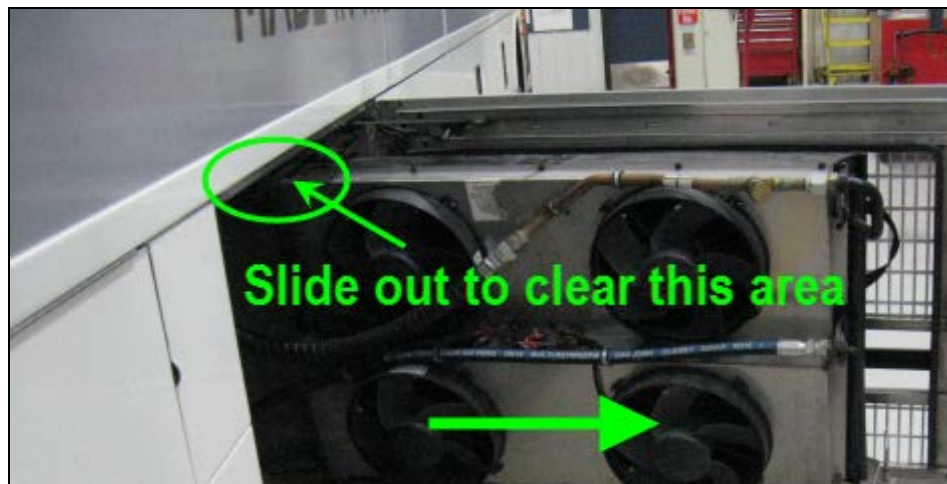

Fig.13

PART 2: UPPER PIVOT PIN INSPECTION AND REMOVAL

9. Inspect the upper pivot pin breakage to determine subsequent actions to be performed before installation of the reinforcing plate. Three breakage type are usually observed:

- **Pin welds broke and pin went out of the condenser leaving a blind hole at the top (Fig.14).**
The hole will need to be progressively enlarged to allow the plate installation. Up to 1/2", uses sharp sheet metal bits (with a 135° tip angle) mounted on an electric drill and mount drill stops at the tip of the drills so they will not penetrate more than 1/4" in the condenser core (Fig.15). Enlarge the 1/2" hole to about 1 inch with a carbide bit (the bottom of the reinforcing plate pin (Fig.22) must fit in the hole).



Fig.14

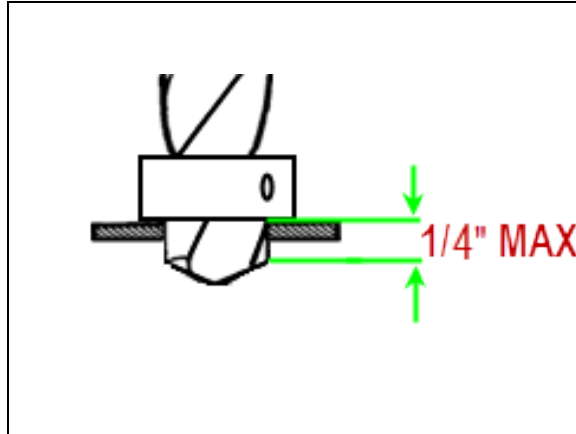

Fig.15



CAUTION

Do not drill pass 1/4" below the pin body or serious damage could occur to the condenser core tubes

- **Pin is sheared and the remaining part of the pin sits flush with the condenser top (Fig.16).**
The pin body will need to be center drilled and the hole enlarged to 1 inch following the steps below.



Fig.16

- Use a center punch to precisely locate the center of the pin (Fig.17).
- Drill the center of the pin with a small 1/8" drill equipped with a drill stop to avoid drilling more than 1/8" deep in the condenser and hitting the core tubes (Fig.18).
- Cut a 1 inch hole with a hole saw using the 1/8" hole as a guide (Fig.19).

NOTE

Bottom of the reinforcement plate pin must fit the hole, enlarge the 1 inch hole with a carbide bit as necessary (see Fig.22)

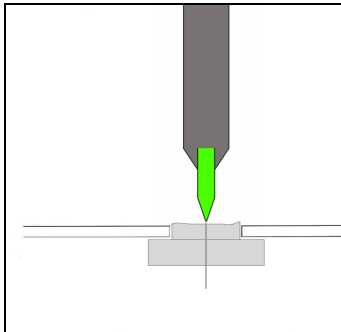

Fig.17

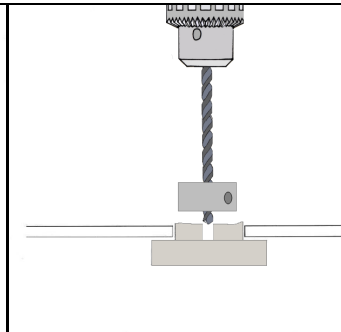

Fig.18

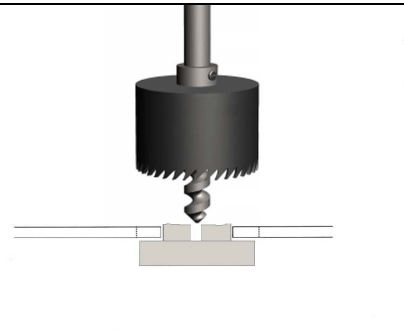

Fig.19



CAUTION

Do not drill pass 1/4" below the pin body or serious damage could occur to the condenser core tubes

- **Pin weld broke but pin is still present and move/spin freely in the condenser top hole.** With an angle grinder and a suitable cutting disk, the pin body will need to be cut flush to the condenser body and then pushed down while enlarging the hole to 1 inch with a hole saw (Fig.20 & 21).

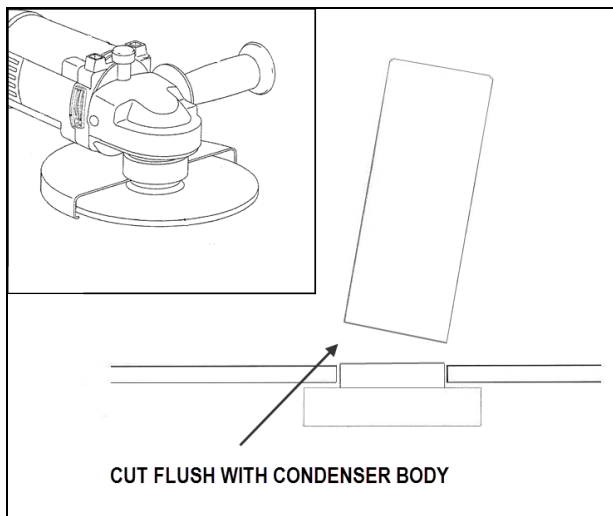

Fig.20

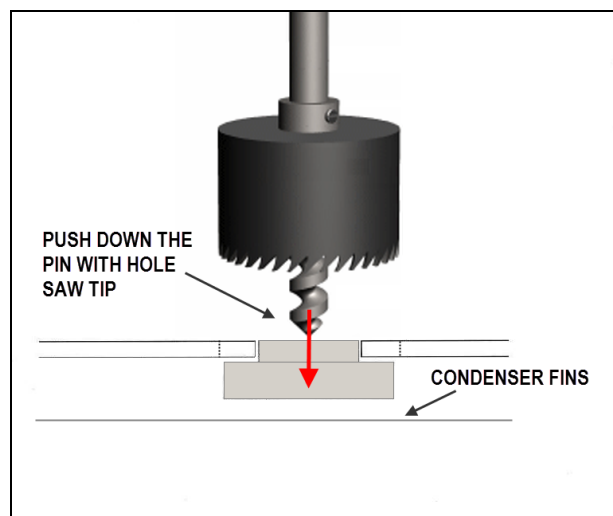

Fig.21



DANGER

Always wear eye protection when using an angle grinder or rotary cutting tools

NOTE

Bottom of the reinforcement plate pin must fit the hole, enlarge the 1 inch hole with a carbide bit as necessary (see Fig.22)

PART 3: REINFORCING PLATE INSTALLATION

10. With the hole enlarged to one inch, position the reinforcing plate at the condenser top. The bottom part of the plate pin must be inserted in the one inch hole and the edges of the plate must fit flush with the condenser body as shown below (Fig.22 & 23).

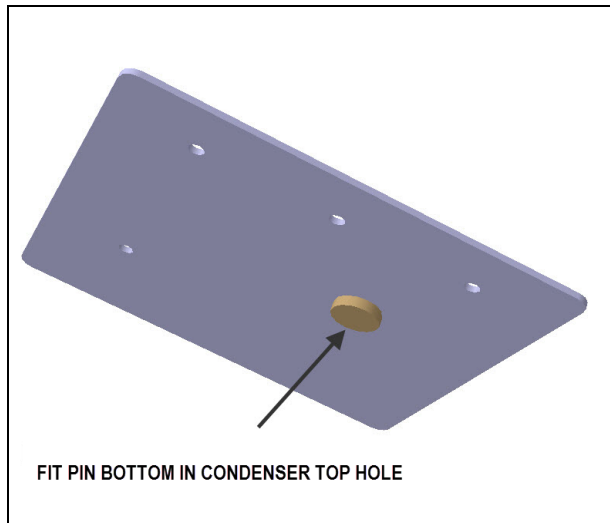

Fig.22

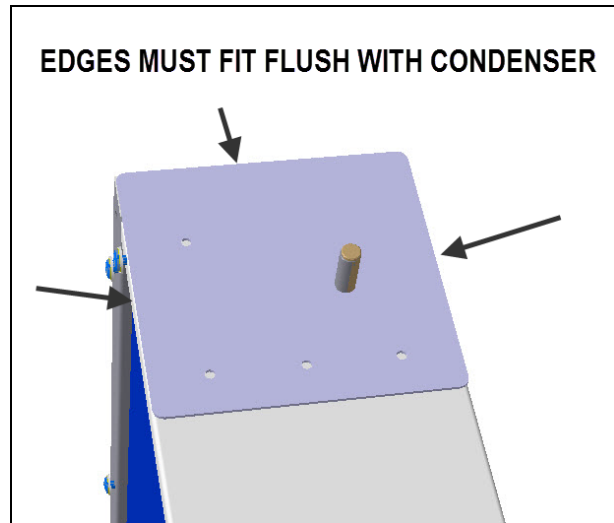

Fig.23

11. With the plate correctly positioned on the condenser top, mark the center of each four (4) rivet holes in the plate (Fig.24).
12. Using a 3/16" drill bit and appropriate *drill stop*, drill four (4) holes at the top of the condenser being careful not to go past the specified 1/4" depth (Fig.25).

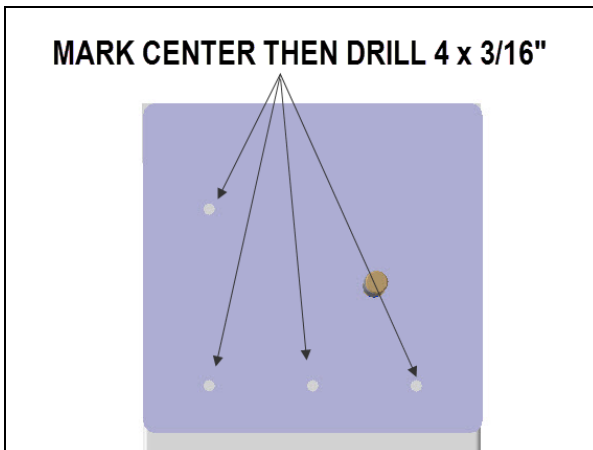

Fig.24

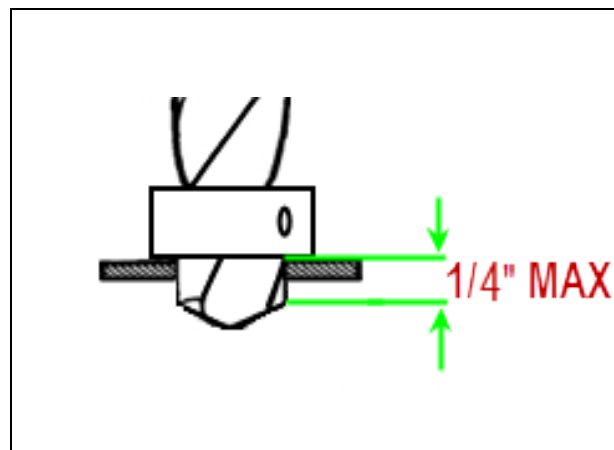

Fig.25

13. Rivet the plate in place using four blind 3/16" rivets and an appropriate rivet gun (Fig.26 & 27).

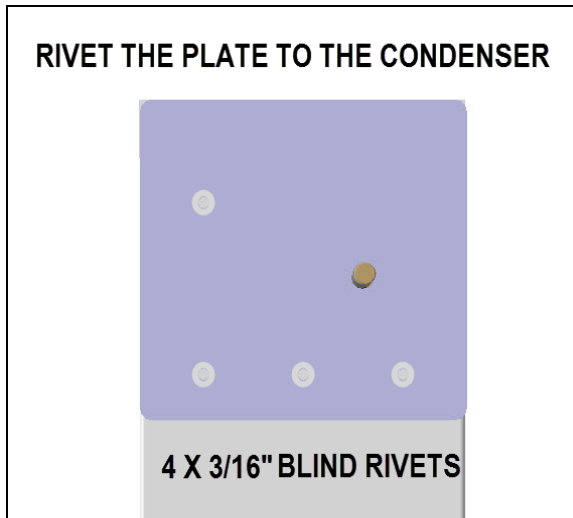

Fig.26

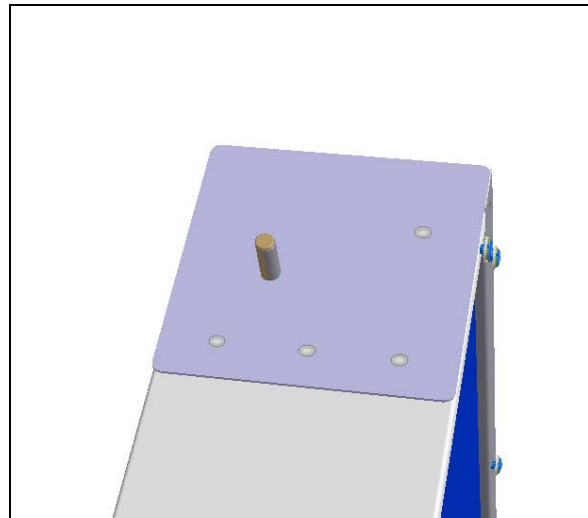

Fig.27

PART 4: CONDENSER REINSTALLATION

14. Carefully slide back and lower the condenser into position (Fig.28) ensuring that the lower pivot pin is positively engaged (Keep the lift table under the condenser to support it).

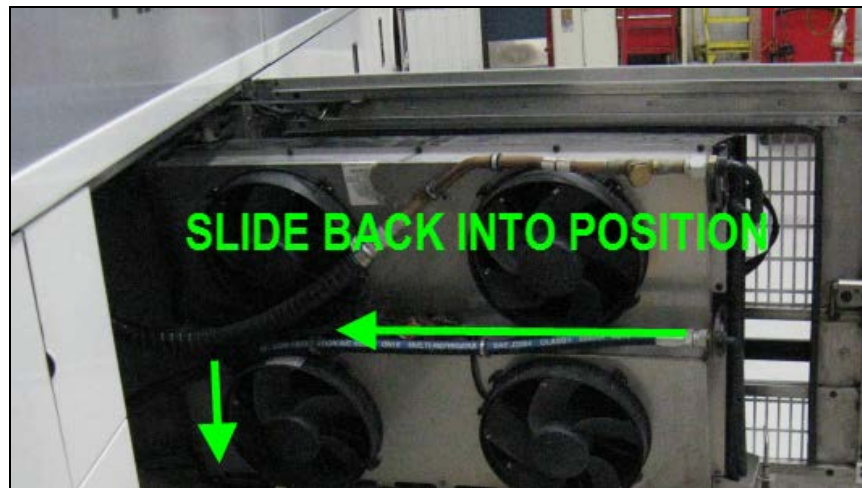

Fig.28

15. On the upper pivot bracket, *slightly* loosen the pivot pin retainer nut so the retainer can freely slide back and forth in the bracket as shown in the illustrations below (Fig.29, 30 & 31).

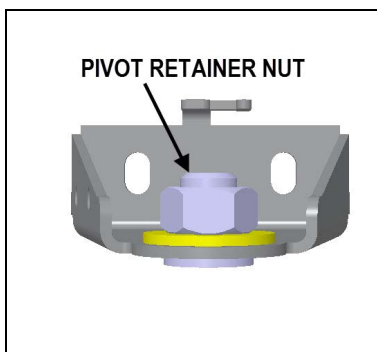

Fig.29

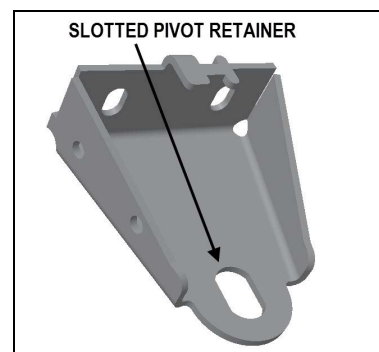

Fig.30

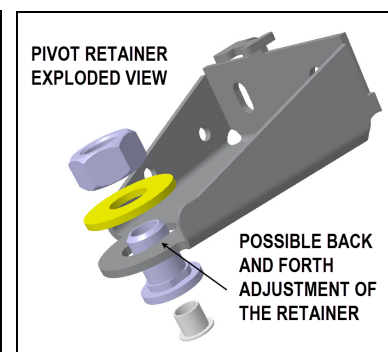

Fig.31

16. Install a new #507260 retainer nylon bushing in the assembly and hand tight the upper bracket in place (Fig 32 & 33).



Fig.32

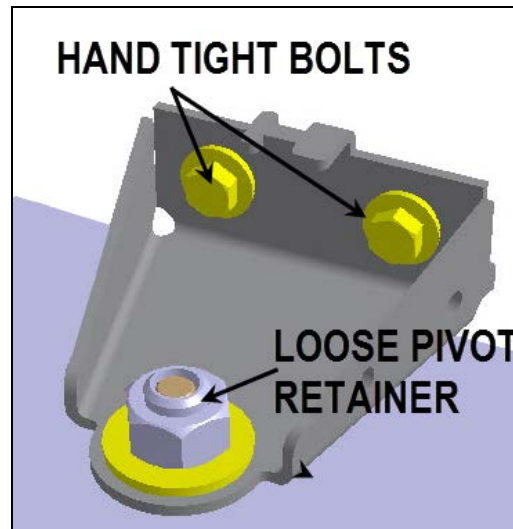
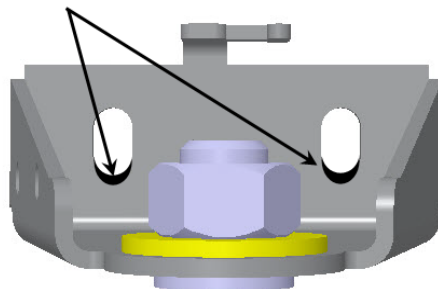

Fig.33

NOTE

On some vehicles, due to the slight difference in upper pin height after the reinforcing plate installation, it may be necessary to slightly enlarge the upper bracket mounting holes with a 9mm carbide bit as shown in the picture below

ENLARGE BOTTOM OF MOUNTING HOLES



17. With the upper bracket loosely fixed, remove the lift table and push back the condenser into the vehicle.
18. Tighten the two two (2) M8 hex bolts to 25 lb-ft.
19. Slightly tighten the retainer bolt and push/pull the condenser in and out a few times to ensure that it is moving freely and that the pin retainer ins in its optimal position.
20. Tighten the retainer nut.
21. Reinstall the two wiring harness to the upper bracket using the supplied cable tie.
22. Reinstall the door limiter strap.

PARTS / WASTE DISPOSAL

Discard waste according to applicable environmental regulations (Municipal/State[Prov.]/ Federal)